



OfficeSource[®]
FURNITURE

Model #: OSGS12881, OSGS12885 & OSGS12887

Name: Bolster



OfficeSource[®]
FURNITURE

officesourcefurniture.com

Customer Service

Tel: 800-388-8202 (Mon-Fri | 9am-5pm EST.)

Assembly & Operation Instructions

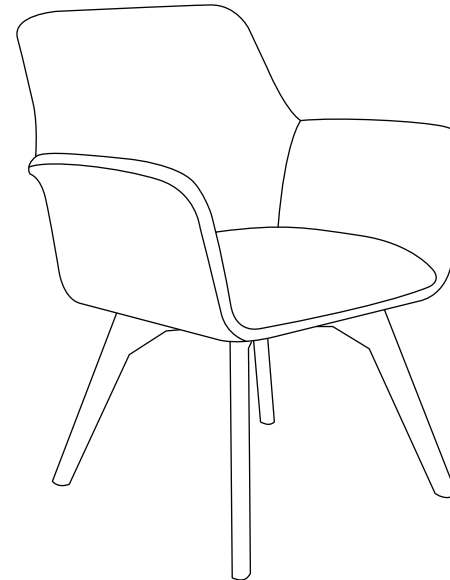

Please read the instruction sheet(s) completely before assembly.

Maximum Weight Load: 275 lbs

Assembly Notes

1. After opening the carton, please carefully check for missing parts and transportation damage and if needed, contact dealer immediately.
2. Once installed, the gas lift will be difficult to remove. It is not recommended to remove the gas lift to avoid damage to other parts of the chair.
3. Contact dealer if disassembly assistance is needed.

Usage Notes

1. Intended for use indoors.
2. Intended for single person use.
3. Do not sit on end of chair to avoid accidental tipping and injury.
4. Do not step or stand on the chair – chair is intended for sitting only.
5. Use caution when reclining, especially as tension is reduced by user.
6. Do not lean against product – chair is intended for sitting only.
7. Avoid contact with sharp objects, heavy tools and hot surfaces.
8. As assembly may loosen overtime, for best user safety, conduct regular check of nuts and bolts to insure they are always tight and secure.
9. To clean, wipe with a soft and dry cleaning cloth. If there are stains on fabric, use a mild detergent to wipe clean.



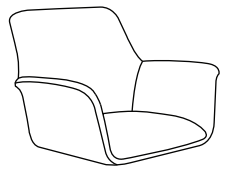
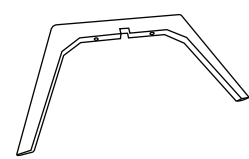

Parts List

Wood Leg Base

 <p>A x 1</p>	 <p>B x 2</p>
--	--

Hardware List

	C x 4		E x 1
	D x 1		



Installation Steps

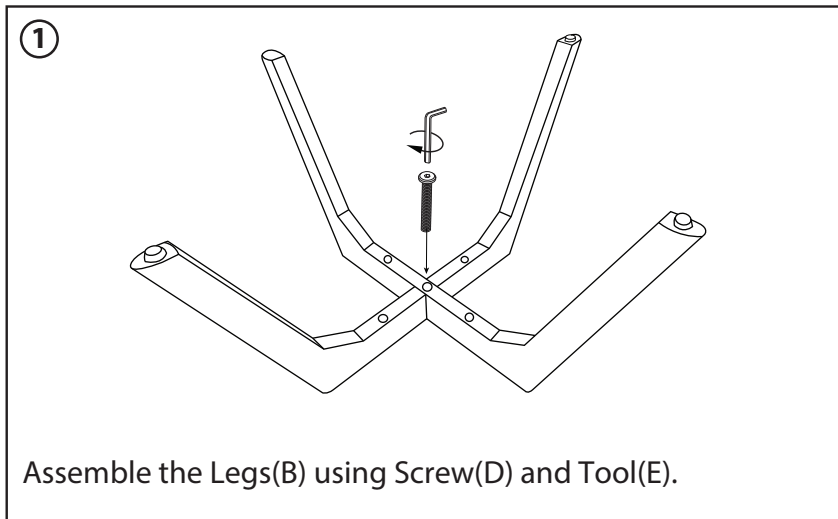

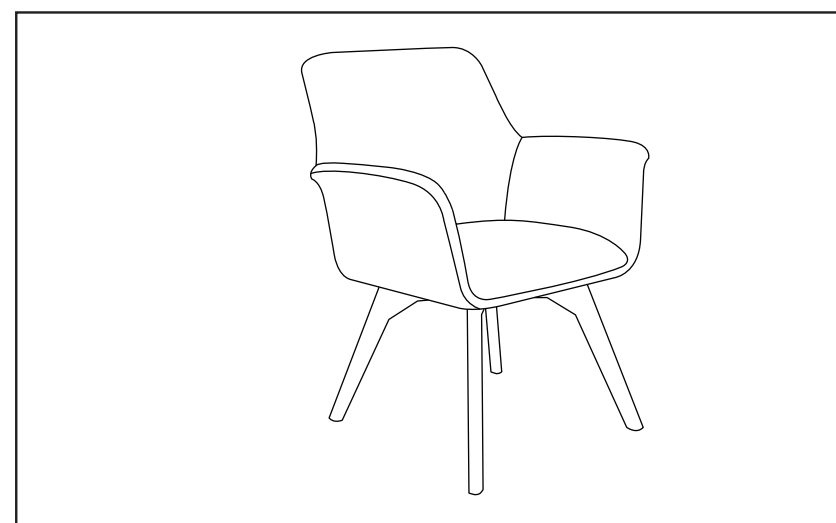
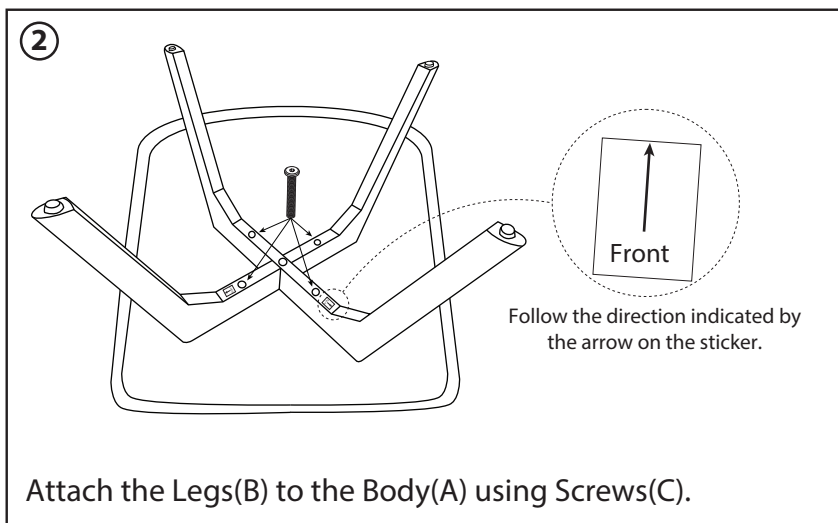
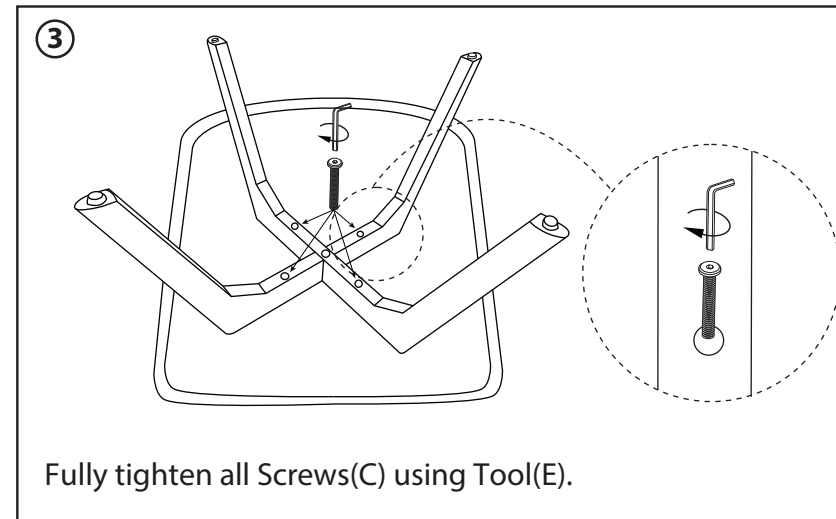

Installation Steps





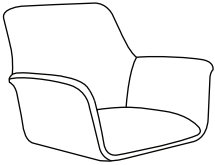
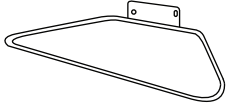



Parts List **Metal Sled Base**

 A x 1	 B x 2	 C x 1
--	--	--

Hardware List

	D x 4		F x 1
	E x 2		G x 4





Installation Steps

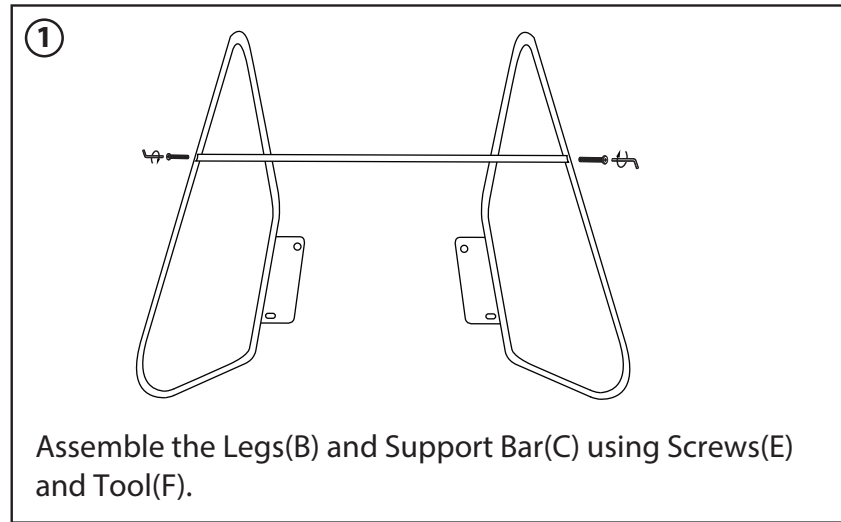



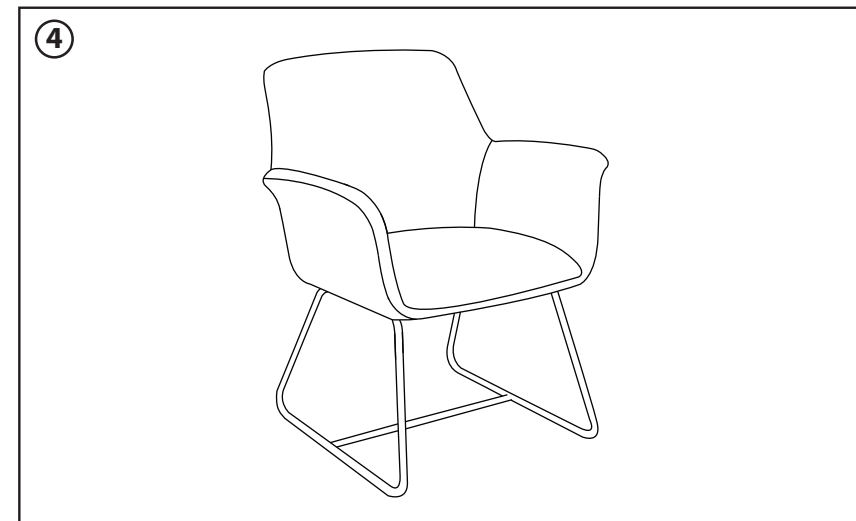
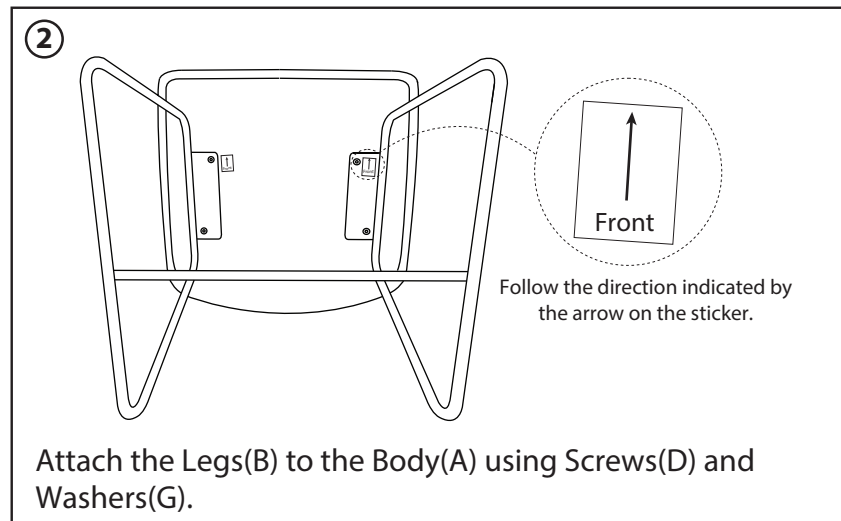
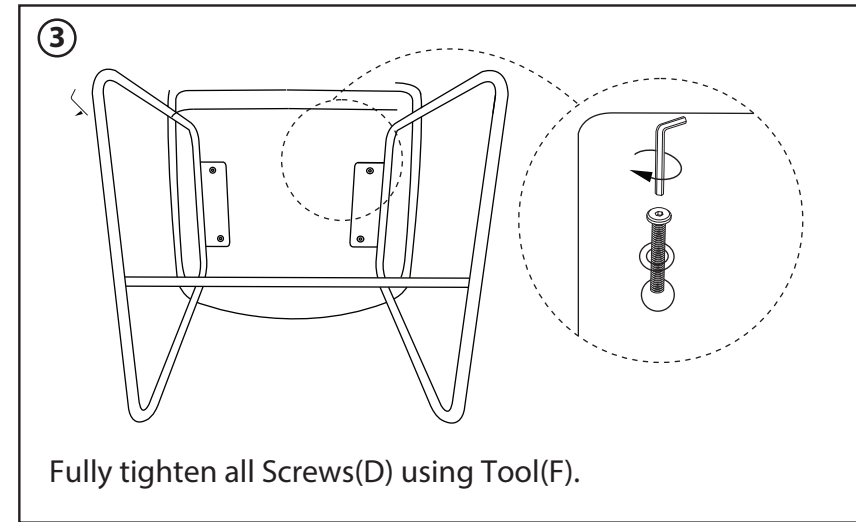

Installation Steps



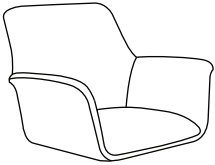

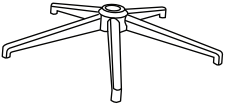
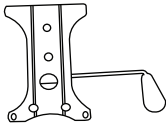

Parts List **Swivel 5 Star Chrome Base**

 <p>A x 1</p>	 <p>B x 1</p>	 <p>C x 5</p>
 <p>D x 1</p>	 <p>E x 1</p>	 <p>F x 1</p>

Hardware List

	G x 4		I x 1
	H x 4		





Installation Steps

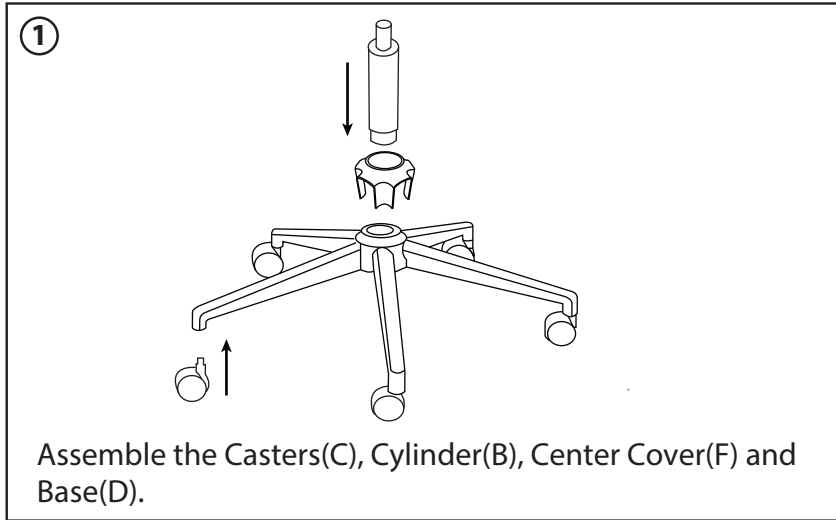

Installation Steps

