

BLICK®

materials for art education

**FREE
SHIPPING**
on orders of \$49
or more!

Some exceptions apply.
See page 648

Artwork by:
Sena Runa
IG: @senaruna

DickBlick.com

2022
800.447.8192

**Welcome to Blick's 2022
Materials for Art Education catalog.**

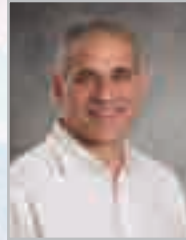

With a new year comes new opportunities for creativity inside the classroom and out. This year, we're thrilled to introduce a variety of new products, plus updates to existing favorites, brand new lesson plans, and a variety of system improvements that will make it easier than ever to help students reach their full creative potential.

Inside these pages, you'll find all of your most trusted supplies for art education. There's something for every project, grade level, and learning environment — from paints and drawing materials to crafts, brushes, ceramics, surfaces, and more. You'll also find additions to our educator-favorite Blick brand products. From new drafting pencils and fluorescent colors found in our Liquid Watercolors, to a convenient Blick Essentials Palette Knife Value Set, there are so many ways to stretch your budget without sacrificing quality.

Our Utrecht brand has long been an artist favorite. Don't miss additions and improvements to several products, including our Utrecht Studio Series Oils. Ideal for introducing students to oil painting, they now come in a convenient, smaller 37 ml size. We're also pleased to introduce Utrecht NOOD Artists' Paint Thinner. Short for "no-odor," NOOD is a safer, 100% odorless thinner that is uniquely suitable for students and professionals alike.

As always, our lesson plan brochure is packed with original ideas for students of all grades and skill levels. This year, there are several brand new lesson plans, all designed to enhance critical thinking, spotlight unique artistic traditions from around the world, and encourage innovation. Created by our Education Development Specialists for educators, each meets National Standards for Visual Art Education.

If you're looking for even more lesson plans, visit our recently updated Resources for Art Educators page at dickblick.com/educators. In addition to a wealth of content created specifically for educators, you'll find information on using our New Quick Quote Tool to create an on-demand quote reflecting your organization's profile and current prices. This convenient resource is a great way to manage the requisition process from quote to order placement.

At Blick, the needs of educators have long been a top priority, and we are grateful for your trust and support. As we continue to absorb and anticipate cost increases associated with the COVID-19 pandemic, which has caused significant volatility in global markets and supply chains, we ask for your understanding if the prices in this catalog change due to these extraordinary circumstances. Please also carefully review updates to FedEx shipping policies and our general shipping information, as some changes have occurred since last year.

If you ever need assistance with a product or order, please do not hesitate to reach out to our dedicated specialists. You can chat with them via Live Chat at DickBlick.com, call 1-800-828-4548, or email custservice@dickblick.com.

Bob Buchsbaum

Bob Buchsbaum
CEO, Blick Art Materials



Learn how **Blick Supports Art Education**
SEE PAGES 642-643

The BLICK Advantage

BEST Prices

- We find the best values, and pass the savings on to you.
- If you find a lower advertised price, we'll match it.
- For even better values, choose from more than 8,000 Blick and Utrecht brand products.

BEST Service & Knowledge

- We have real people available to answer your questions 24/7.
- Hundreds of Blick videos are also posted on DickBlick.com and on YouTube.com, including video lesson plans for art educators and product demonstrations for artists.

BEST Selection

- We know making art often requires materials that are hard to find.
- Need something specific? We have what you need for every creative endeavor — more than 90,000 products in all!

BEST Availability

- Most orders are processed within 24 hours, and we NEVER cancel a backorder unless you ask us to.
- As soon as we receive your items, we ship them out immediately at NO additional cost to you.

BLICK Ships Quick
Our reputation for industry-leading shipping times means you'll get your order FAST!

Details on page 648.



art educators,
LOOK INSIDE
for exciting featured
LESSON PLANS
between pages 360 and 361.
You'll also find these lesson plans
and more at DickBlick.com/lesson-plans.

ON THE COVER: **Underwater World by Sena Runa**
senaruna.com







































Artist Sena Runa discovered a talent for paper quilling in 2013 while working as an HR specialist. Two years later, she left the corporate world behind in pursuit of her creative passion. Now a full-time artist, she is known for her fresh and joyful paper quilling artwork. She has worked on high-profile projects for companies such as Royal Caribbean Cruises, Progressive Insurance, Essie, and others.

The author of two paper quilling tutorial books, her guides contain fun, original projects for beginners and experienced quillers alike. Her books have been translated into Dutch, Chinese, and Finnish. Find Sena Runa's book, "Quilling Art", on page 620.



Table of Contents

 Paints 4-77	 Sculpture 484-497
 Tools & Accessories 78-88	 Ceramics 498-537
 Brush Information 89-90	 Understanding Pottery Wheels 507
 Brushes 91-141	 What You Should Know Before Buying a Kiln 514
 Canvas & Panels 142-163	 Safety & Health 538-539
 Papers & Boards 164-226	 Adhesives 540-557
 Framing 227-253	 Cutting Tools 558-569
 Presentation 254-259	 Easels 570-578
 Drawing 260-343	 Furniture & Lighting 579-593
 Graphic Arts 344-356	 Display & Presentation 594-611
 Airbrushing 357-364	 Storage 612-618
 Printmaking 365-405	 Books & Media 619-628
 Blick Printing Press Comparison Chart 386	 Index 629-641
 Guide to Screen Printing Films & Emulsions 403	 Support for Art Educators 642-643
 Textile Arts 406-423	 Health & Safety Information 644
 Crafts 424-477	 Metric to U.S. Conversion 645
 Molding & Casting 478-483	 Visit Our Stores 646
	 Customer Service 647
	 Ordering Information 648

2022 PRICING NOTE

Blick is committed to doing our best to make the necessary sacrifices so that prices in this catalog can be honored throughout 2022. In some cases, we may be able to lower prices if vendors do not raise prices to the extent estimated at the time of publishing this catalog. However, as vendors provide mid-year price increases, we cannot guarantee printed prices in this catalog — all prices are subject to change without notice. As of now, no more than a handful of products required mid-year adjustments, but this year may be an exception. Further, continuing supply chain disruptions have made it difficult to stay in stock on select items, and unfortunately vendors are taking much longer than usual to fill back orders. We ask for your understanding in these unprecedented times. As always, Blick reserves the right to typographical errors.

**"Best value,
best quality for
classroom paints!"**
- Educator from MI
Blickrylic
pages 30-31



**"I highly recommend
this supreme quality
tempera paint."**
- Educator from CA
Blick Tempera
pages 4-6

**"Great value pencils
for classroom use."**
- Educator from IL
**Blick Studio Drawing
Pencil Class Pack**
page 332

**"Fantastically
versatile paper!"**
- Educator from MA
**Blick White Sulphite
Drawing Paper**
page 200



**"Great for learning how
to blend colored pencils."**
- Educator from VA
Blick Studio Artists' Colored Pencils
page 323



Classroom Favorites!

★★★★★ Reviewed & rated by teachers like you!

2022 classroom HIGHLIGHTS



Pony Beads
Page 432



Sakura Cray-Pas Junior Artist Oil Pastel Sets
Page 307



Spectrum Low Fire Metallic Glazes
Page 534



Blick Economy Cotton Canvas Panels
Page 147



Blick Studio Pastel Sets
Page 310



Blick Academic Canvas
Page 144



Yasutomo Student Origami Class Packs
Page 459



Blick Essentials Palette Knife Value Set
Page 92

NEW!



Patchwork Mosaic Tiles
Page 470



NEW!

Blick Fluorescent Liquid Watercolors
Page 27



NEW!

Colorberry Geode Resin
Page 74



NEW!

Angora Watercolor Sets
Page 21



Blick Mesh Zipper Bags
Page 259

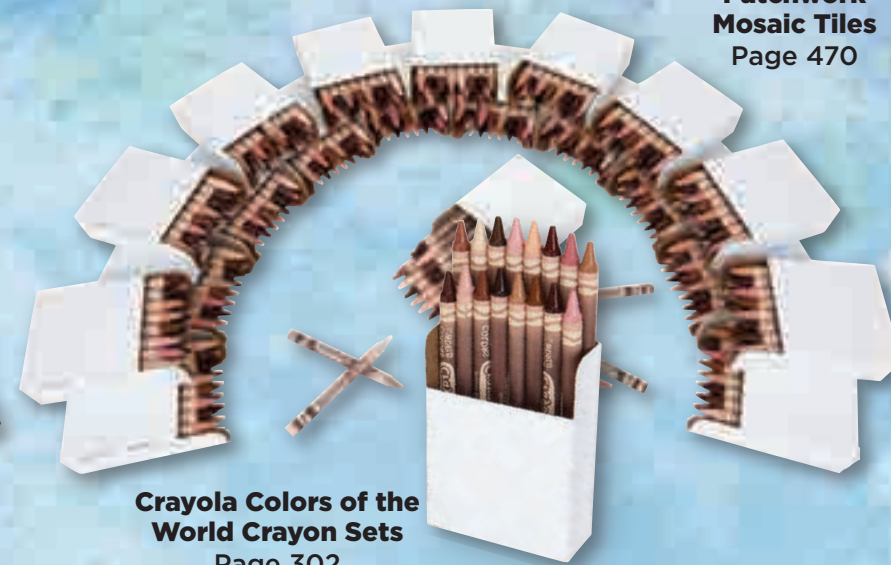

Crayola Colors of the World Crayon Sets
Page 302

NEW!

Sakura Koi Creative Art Colors Watercolor Sets
Page 21



BLICK essentials tempera

GOOD BETTER BEST

AS LOW AS \$14.32 per GALLON

- The budget-minded teacher's best value
- Highly pigmented, brilliant, and rich
- Creamy-smooth consistency
- Lead-free and AP certified non-toxic
- Made in the USA

Blick' Essentials Tempera



This is your first choice for fine quality and economy. Formulated with student safety in mind, Blick Essentials Tempera doesn't contain latex, dairy, casein, soy, egg, gluten, peanuts, tree nuts, or other allergens. It cleans up easily with soap and water and is freeze-thaw stable. Colors can be assorted for quantity pricing.

COLOR	8 OZ (237 ML)	PINT (473 ML)	QUART (946 ML)	GALLON (3.78 L)
Black	A00057-2005	A00057-2006	A00057-2007	A00057-2009
Blue	A00057-5005	A00057-5006	A00057-5007	A00057-5009
Brown	A00057-8005	A00057-8006	A00057-8007	A00057-8009
Green	A00057-7005	A00057-7006	A00057-7007	A00057-7009
Magenta	A00057-3055	A00057-3056	A00057-3057	A00057-3059
Orange	A00057-4505	A00057-4506	A00057-4507	A00057-4509
Peach	A00057-4105	A00057-4106	A00057-4107	A00057-4109
Red	A00057-3005	A00057-3006	A00057-3007	A00057-3009
Turquoise	A00057-5115	A00057-5116	A00057-5117	A00057-5119
Violet	A00057-6505	A00057-6506	A00057-6507	A00057-6509
White	A00057-1005	A00057-1006	A00057-1007	A00057-1009
Yellow	A00057-4005	A00057-4006	A00057-4007	A00057-4009
EACH	\$2.94	EACH \$3.31	EACH \$5.04	EACH \$16.74
12/EA	2.64	12/EA 2.99	12/EA 4.50	4/EA 15.11
24/EA	2.51	24/EA 2.86	24/EA 4.27	12/EA 14.32



Blick' Essentials Tempera Metallic Colors



Colors can be assorted for quantity pricing.

COLOR	8 OZ (237 ML)	PINT (473 ML)	QUART (946 ML)
Brass	A00057-9075	A00057-9076	A00057-9077
Copper	A00057-9515	A00057-9516	A00057-9517
Gold	A00057-9025	A00057-9026	A00057-9027
Silver	A00057-9325	A00057-9326	A00057-9327
Treasure Gold	A00057-9225	A00057-9226	A00057-9227
EACH	\$4.23	EACH \$8.31	EACH \$14.23
12/EA	3.98	12/EA 7.48	4/EA 13.52
24/EA	3.70	24/EA 7.07	12/EA 12.80

Blick' Essentials Tempera Fluorescent Colors



Colors can be assorted for quantity pricing.

COLOR	8 OZ (237 ML)	PINT (473 ML)
Fluor Blue	A00057-5245	A00057-5246
Fluor Green	A00057-7275	A00057-7276
Fluor Hot Pink	A00057-3485	A00057-3486
Fluor Magenta	A00057-3045	A00057-3046
Fluor Orange	A00057-4565	A00057-4566
Fluor Red	A00057-3745	A00057-3746
Fluor Violet	A00057-6915	A00057-6916
Fluor Yellow	A00057-4225	A00057-4226
EACH	\$5.28	EACH \$10.18
12/EA	4.73	12/EA 9.46
24/EA	4.51	24/EA 8.98

Lockable Pump Lids

Dispense paints neatly and easily. The locking mechanism keeps paint inside the containers, and keeps containers clean. Created for use with Blick Tempera paints and Blickrylics 1/2 and 1 gallon containers.

NUMBER	SIZE	EACH	12/EA	24/EA
A02909-1009	Gallon	\$3.38	\$3.04	\$2.89
A02909-0080	Half Gallon	3.38	3.04	2.89



BLICK student tempera

GOOD BETTER BEST

AS LOW AS \$23.34 GALLON

- Comparable to premium temperas at an amazing value
- Thicker and brighter than other student-grade temperas
- Outstanding pigment strength and coverage
- Lightfast, lead-free, and AP certified non-toxic
- Made in the USA

Blick' Student Tempera



You'll be amazed by how much thicker and brighter Blick Student Tempera is compared to other brands. Made with more top-quality pigments and less filler and water, it won't sag, drip, flake, chip, or crack. Formulated with student safety in mind, it doesn't contain latex, dairy, casein, soy, egg, gluten, peanuts, tree nuts, or other allergens. Cleans with soap and water. Freeze-thaw stable. Colors can be assorted for quantity pricing.

COLOR	8 OZ (237 ML)	PINT (473 ML)	QUART (946 ML)	HALF GALLON (1.89 L)	GALLON (3.78 L)
Almond	A00018-8235	A00018-8236	—	—	—
Bisque	A00018-3515	A00018-3516	—	—	—
Black	A00018-2005	A00018-2006	A00018-2007	A00018-2008	A00018-2009
Blue	A00018-5005	A00018-5006	A00018-5007	A00018-5008	A00018-5009
Brown	A00018-8005	A00018-8006	A00018-8007	A00018-8008	A00018-8009
Burnt Sienna	A00018-8045	A00018-8046	—	—	—
Cinnamon	A00018-3765	A00018-3766	—	—	—
Curry	A00018-4885	A00018-4886	—	—	—
Green	A00018-7005	A00018-7006	A00018-7007	A00018-7008	A00018-7009
Magenta	A00018-3045	A00018-3046	A00018-3047	A00018-3048	A00018-3049
Orange	A00018-4505	A00018-4506	A00018-4507	A00018-4508	A00018-4509
Peach	A00018-4105	A00018-4106	A00018-4107	A00018-4108	A00018-4109
Red	A00018-3005	A00018-3006	A00018-3007	A00018-3008	A00018-3009
Turquoise	A00018-5115	A00018-5116	A00018-5117	A00018-5118	A00018-5119
Violet	A00018-6505	A00018-6506	A00018-6507	A00018-6508	A00018-6509
Walnut	A00018-7075	A00018-7076	—	—	—
White	A00018-1005	A00018-1006	A00018-1007	A00018-1008	A00018-1009
Yellow	A00018-4005	A00018-4006	A00018-4007	A00018-4008	A00018-4009
EACH	\$4.03	EACH \$5.19	EACH \$8.57	EACH \$14.68	EACH \$27.30
12/EA	3.63	12/EA 4.65	12/EA 7.72	6/EA 13.19	4/EA 24.57
24/EA	3.45	24/EA 4.42	24/EA 7.32	12/EA 12.55	12/EA 23.34



Blick' Student Tempera 6-Color Pump Kits



Kits contain one each of Red, Yellow, Blue, Green, Black, and White, plus six lockable pump lids and 100 paint cups.

NUMBER	SIZE	EACH
A00018-1019	Gallons (3.78 Liter)	\$133.17
A00018-0089	Half Gallons (1.89 Liter)	71.68

Blick' Student Tempera 4-Color Pump Kits



Kits include Gallon (3.78 Liter) bottles, four lockable pump lids, and 100 paint cups.

NUMBER	SIZE	EACH
A00018-1029	Gallons	\$92.59

Secondary Colors — Green, Orange, Brown, and Black.

NUMBER	SIZE	EACH
A00018-1039	Gallons	\$92.59



Blick' Student Tempera Multicultural 8-Color Kit



Almond, Bisque, Walnut, Curry, Cinnamon, Burnt Sienna, Brown, and Peach.

NUMBER	SIZE	EACH
A00018-1069	Pints	\$30.72

Did you know we have hundreds of lesson plans designed to meet the National Standards for Visual Arts Education? See them all at DickBlick.com/lesson-plans.

Blick' Student Tempera 6-Color Kit



Red, Yellow, Blue, Green, Black, and White in a convenient carry carton.

NUMBER	SIZE	EACH
A00018-1001	Pints	\$25.27

BLICK premium tempera

AS LOW AS
\$28.92
GALLON



- Simply the best-quality tempera in the industry
- Extraordinary pigment strength, coverage, and lightfastness
- Creamy and thick yet flows beautifully
- Lead-free and AP certified non-toxic
- Made in the USA

When compared to other brands, you will find no better tempera in terms of pigment strength, coverage, and consistency — a free-flowing formula that brings out the best in every young artist. Formulated with safety in mind, it doesn't contain latex, dairy, casein, soy, egg, gluten, peanuts, tree nuts, or other allergens. Cleans with soap and water. Freeze-thaw stable. **Colors can be assorted for quantity pricing.**

COLOR	8 OZ (237 ML)	PINT (473 ML)	QUART (946 ML)	HALF GALLON (1.89 L)	GALLON (3.78 L)
Black	A00011-2005	A00011-2006	A00011-2007	A00011-2008	A00011-2009
Blue	A00011-5005	A00011-5006	A00011-5007	A00011-5008	A00011-5009
Brown	A00011-8005	A00011-8006	A00011-8007	A00011-8008	A00011-8009
Burnt Sienna	A00011-8045	A00011-8046	A00011-8047	A00011-8048	A00011-8049
Emerald Grn	A00011-7055	A00011-7056	A00011-7057	A00011-7058	A00011-7059
Green	A00011-7005	A00011-7006	A00011-7007	A00011-7008	A00011-7009
Magenta	A00011-3045	A00011-3046	A00011-3047	A00011-3048	A00011-3049
Orange	A00011-4505	A00011-4506	A00011-4507	A00011-4508	A00011-4509
Peach	A00011-4105	A00011-4106	A00011-4107	A00011-4108	A00011-4109
Red	A00011-3005	A00011-3006	A00011-3007	A00011-3008	A00011-3009
Turquoise	A00011-5115	A00011-5116	A00011-5117	A00011-5118	A00011-5119
Violet	A00011-6505	A00011-6506	A00011-6507	A00011-6508	A00011-6509
White	A00011-1005	A00011-1006	A00011-1007	A00011-1008	A00011-1009
Yellow	A00011-4005	A00011-4006	A00011-4007	A00011-4008	A00011-4009
Yellow-Green	A00011-7345	A00011-7346	A00011-7347	A00011-7348	A00011-7349
EACH	\$5.75	\$8.25	\$11.89	\$22.24	\$33.43
12/EA	5.33	7.43	10.82	19.99	30.43
24/EA	5.05	7.06	10.28	18.99	28.92

COLOR	8 OZ (237 ML)	PINT (473 ML)	QUART (946 ML)	HALF GALLON (1.89 L)	GALLON (3.78 L)
Gold	A00011-9005	A00011-9006	A00011-9007	A00011-9008	A00011-9009
Silver	A00011-9305	A00011-9306	A00011-9307	A00011-9308	A00011-9309
EACH	\$8.46	\$11.30	\$21.79	\$37.28	\$67.78
12/EA	7.73	10.50	20.31	34.43	61.05
24/EA	7.35	9.98	19.30	32.72	57.99

Primary 2 oz



Fluorescent 4 oz

Blick Premium Tempera Sets of 6

NUMBER	DESCRIPTION	SIZE	EACH
A00011-1059	Primary	2 oz	\$11.32
A00011-1029	Fluorescent	2 oz	\$12.51
A00011-1039	Primary	4 oz	\$15.85
A00011-1049	Fluorescent	4 oz	\$17.76



Blick Premium Tempera 6-Color Kits

Kits include six pints in a convenient carry carton. **Basic Colors** — Red, Yellow, Blue, Green, Black, and White. **Fluorescent Colors** — Blue, Green, Pink, Red, Yellow, and Yellow-Orange.

Blick Premium Tempera Fluorescent Colors

Colors can be assorted for quantity pricing.

COLOR	NUMBER	EACH	12/EA	24/EA
Blue	A00011-5246		\$11.62	\$10.74
Green	A00011-7266			\$10.20
Pink	A00011-3716			
Red	A00011-3216			
Yellow	A00011-4216			
Yellow-Orange	A00011-4916			



Blick Premium Tempera 6-Color Pump Kits

Kits contain one each of Red, Yellow, Blue, Green, Black, and White, plus six lockable pump lids and 100 paint cups.

NUMBER	SIZE	EACH
A00011-0089	Half Gallons (1.89 Liter)	\$123.17
A00011-0099	Gallons (3.78 Liter)	187.76

Blick Premium Tempera 4-Color Pump Kits

Kits include Gallon (3.78 Liter) bottles, four lockable pump lids, and 100 paint cups. **Primary Colors** — Red, Yellow, Blue, and White. **Secondary Colors** — Green, Orange, Brown, and Black.

NUMBER	SIZE	EACH
A00011-0079	Gallons (3.78 Liter)	\$127.16
A00011-0059	Gallons (3.78 Liter)	\$127.16

Blick Premium Tempera Jar Set

A set of six basic colors in 0.75 oz (22 ml) jars: Red, Yellow, Blue, Green, White, and Black.

NUMBER	EACH
A00011-0039	\$11.59



Crayola Artista II Liquid Washable Tempera

An economically priced washable tempera paint. Use for painting and screen printing. Non-separating and freeze-thaw stable. **Colors can be assorted for quantity pricing.**

Set of 12 — Includes 16 oz (473 ml) bottles of Black, Blue, Brown, Green, Magenta, Orange, Peach, Red, Turquoise, Violet, White, and Yellow.

NUMBER	EACH	12/EA
A00020-0129	\$47.97	\$43.17

Primary Set of 3 Colors — Includes one 8 oz (236 ml) bottle each of Red, Yellow, and Blue.

NUMBER	EACH	12/EA
A00020-1039	\$7.96	\$7.17

Secondary Set of 3 Colors — Includes one 8 oz (236 ml) bottle each of Orange, Green, and Violet.

NUMBER	EACH	12/EA
A00020-2039	\$7.96	\$7.17

Neutral Set of 3 Colors — Includes one 8 oz (236 ml) bottle each of Black, White, and Brown.

NUMBER	EACH	12/EA
A00020-3039	\$7.96	\$7.17

COLOR	16 OZ (473 ML)	32 OZ (946 ML)
Black	A00020-2006	A00020-2007
Blue	A00020-5006	A00020-5007
Brown	A00020-8006	A00020-8007
Green	A00020-7006	A00020-7007
Magenta	A00020-3046	A00020-3047
Orange	A00020-4506	A00020-4507
Peach	A00020-4106	A00020-4107
Red	A00020-3006	A00020-3007
Turquoise	A00020-5116	A00020-5117
Violet	A00020-6506	A00020-6507
White	A00020-1006	A00020-1007
Yellow	A00020-4006	A00020-4007
EACH	\$4.68	EACH \$7.96
12/EA	4.21	12/EA 7.17



Set of 12 — Includes 16 oz (473 ml) bottles of Black, Blue, Brown, Green, Magenta, Orange, Peach, Red, Turquoise, Violet, White, and Yellow.

NUMBER	EACH	3/EA
A00007-1009	\$56.05	\$50.44

Multicultural Set — Includes 8 oz (236 ml) bottles of Beige, Bronze, Brown, Mahogany, Olive, Peach, Tan, and Terra Cotta.

NUMBER	EACH	3/EA
A00007-0089	\$26.10	\$23.49



Set of 6 Metallic Colors — Includes 2 oz (59 ml) bottles of Metallic Red, Metallic Orange, Metallic Yellow, Metallic Blue, Metallic Green, and Metallic Purple.

NUMBER	EACH	6/EA
A00034-1629	\$9.56	\$8.60

Set of 6 Glitter Colors — Includes 2 oz (59 ml) bottles of Glitter Red, Glitter Orange, Glitter Yellow, Glitter Blue, Glitter Green, and Glitter Purple.

NUMBER	EACH	6/EA
A00034-2629	\$9.56	\$8.60

Set of 6 Assorted — Includes 2 oz (59 ml) bottles of Blue, Violet, Green, Red, Yellow, and Orange.

NUMBER	EACH	6/EA
A00034-0069	\$5.46	\$4.91

Silly Scents™ Set of 6 — This set includes 2 oz (59 ml) jars of scented Cherry (Red), Orange (Orange), Pineapple (Yellow), Green Apple (Green), Blueberry (Blue), and Fruit Punch (Violet).

NUMBER	EACH	6/EA
A00034-3629	\$7.99	\$7.20

Crayola Washable Paint

Pre-school paint washes easily from skin and nearly all children's clothing. Creamy consistency will not chip or rub off. Non-separating and freeze-thaw stable. **Colors can be assorted for quantity pricing.**

COLOR	16 OZ (473 ML)	GALLON (3.78 LITER)
Black	A00007-2006	A00007-2009
Blue	A00007-5006	A00007-5009
Brown	A00007-8006	A00007-8009
Green	A00007-7006	A00007-7009
Magenta	A00007-3046	A00007-3049
Orange	A00007-4506	A00007-4509
Peach	A00007-4106	A00007-4109
Red	A00007-3006	A00007-3009
Turquoise	A00007-5116	A00007-5119
Violet	A00007-6506	A00007-6509
White	A00007-1006	A00007-1019
Yellow	A00007-4006	A00007-4009
EACH	\$5.25	EACH \$25.29
12/EA	4.72	4/EA 22.76



Set of 10 Neon Colors — Includes 2 oz (59 ml) bottles of Neon Red, Neon Blue, Neon Yellow, Neon Purple, Neon Pink, Neon Orange, Neon Magenta, Neon Green, Black, and White.

NUMBER	EACH	6/EA
A00034-1029	\$9.56	\$8.60

CRAYOLA

All CRAYOLA paint is non-separating & freeze-thaw stable.

Crayola Premier™ Tempera

A top-grade, resin-based liquid tempera that comes in a convenient squeeze bottle with flip-top cap. Brilliant, opaque colors flow easily, cover well, and dry to a velvety, matte finish. Non-separating and freeze-thaw stable. **Colors can be assorted for quantity pricing.**

COLOR	16 OZ (473 ML)	32 OZ (946 ML)
Black	A00012-2006	A00012-2007
Blue	A00012-5006	A00012-5007
Brown	A00012-8006	A00012-8007
Green	A00012-7006	A00012-7007
Magenta	A00012-3046	A00012-3047
Orange	A00012-4506	A00012-4507
Peach	A00012-3356	A00012-3357
Red	A00012-3006	A00012-3007
Turquoise	A00012-5116	A00012-5117
Violet	A00012-6506	A00012-6507
White	A00012-1006	A00012-1007
Yellow	A00012-4006	A00012-4007
EACH	\$9.79	EACH \$15.29
12/EA	8.81	6/EA 13.76

Fluorescent Colors — 16 oz (473 ml) bottles.

NUMBER	COLOR	EACH	12/EA
A00012-5246	Fluorescent Blue	\$14.07	\$12.66
A00012-4917	Fluorescent Chartreuse		
A00012-7266	Fluorescent Green		
A00012-4916	Fluorescent Org-Ylw		
A00012-3717	Fluorescent Pink		
A00012-3216	Fluorescent Red		

Metallic Colors — 16 oz (473 ml) bottles.

NUMBER	COLOR	EACH	12/EA
A00012-9006	Gold	\$15.32	\$13.79
A00012-9306	Silver		



Set of 12 — Includes 16 oz (473 ml) bottles of Blue, Green, Peach, Violet, Magenta, Red, White, Brown, Orange, Yellow, Turquoise, and Black.

NUMBER	EACH	12/EA
A00012-0129	\$99.12	\$89.21

Crayola Paint Pot Set of 42

42, 0.17 oz (5 ml) paint pots in a range of colors, including Glitter and Metallic paints for special effects. Two premium brushes included. Use the storage container as a tray for mixing colors.

NUMBER	EACH	6/EA
A00034-1429	\$21.85	\$19.66

PRANG



Prang® Tempera Paint

This ready-to-use tempera won't settle or separate in the bottle, so it never needs shaking or stirring. Just pour and paint! Prang gives rich, opaque, matte coverage and mixes with other temperas. Watersoluble. Non-toxic. **Colors can be assorted for quantity pricing.**

COLOR	16 OZ (473 ML)	32 OZ (946 ML)	GALLON (3.78 LITER)
Black	A00021-2006	A00021-2007	A00021-2019
Blue	A00021-5006	A00021-5007	A00021-5009
Brown	A00021-8006	A00021-8007	A00021-8009
Green	A00021-7006	A00021-7007	A00021-7009
Magenta	A00021-3046	A00021-3047	A00021-3049
Orange	A00021-4506	A00021-4507	A00021-4509
Peach	A00021-4106	A00021-4107	A00021-4109
Red	A00021-3006	A00021-3007	A00021-3009
Turquoise	A00021-5116	A00021-5117	A00021-5119
Violet	A00021-6506	A00021-6507	A00021-6509
White	A00021-1006	A00021-1007	A00021-1019
Yellow	A00021-4006	A00021-4007	A00021-4009
EACH	\$4.46	EACH \$8.89	EACH \$36.73
12/EA	3.92	12/EA 7.99	3/EA 30.85
24/EA	3.73	24/EA 7.62	6/EA 29.30

Set of 12 Assorted Colors — One each of the colors above in 16 oz (473 ml) squeeze bottles.

NUMBER	EACH	12/EA
A00021-1009	\$57.73	\$51.95

Prang® Washable Tempera

Bright, vibrant colors blend easily and have good working characteristics. Ready-to-use formula means there's no need to shake before use. Ultra-Washable technology makes cleanup easy. Ideal for pre-kindergarten and elementary children. Non-toxic. **Colors can be assorted for quantity pricing.**

COLOR	16 OZ (473 ML)	GALLON (3.78 LITER)
Black	A00045-2026	A00045-8009
Blue	A00045-5016	A00045-5019
Brown	A00045-8006	A00045-1029
Green	A00045-7016	A00045-7019
Magenta	A00045-3046	A00045-3049
Orange	A00045-4516	A00045-4519
Peach	A00045-3756	A00045-3759
Red	A00045-3016	A00045-3019
Turquoise	A00045-5116	A00045-5119
Violet	A00045-6516	A00045-6519
White	A00045-1026	A00045-2029
Yellow	A00045-4016	A00045-4019
EACH	\$4.23	EACH \$24.34
12/EA	3.80	3/EA 21.91
24/EA	3.61	6/EA 20.81

For 8 oz (237 ml) bottles of Prang® Washable Tempera, visit DickBlick.com.

Assorted Set of 12 — Black, Blue, Brown, Green, Magenta, Orange, Peach, Red, Turquoise, Violet, White, and Yellow.

NUMBER	SIZE	EACH	12/EA
A00045-0129	16 oz (473 ml)	\$38.99	\$35.11

Fluorescent Set of 6 — Fluorescent Green, Fluorescent Orange, Fluorescent Pink, Fluorescent Yellow, Metallic Turquoise, and Glitter Red.

NUMBER	SIZE	EACH	12/EA
A00045-0366	16 oz (473 ml)	\$40.46	\$36.42

Set of 8 with Brush — Blue, Brown, Green, Orange, Purple, Red, White, and Yellow, plus a paintbrush.

NUMBER	SIZE	EACH	12/EA
A00045-1089	0.8 oz (25 ml)	\$5.03	\$4.53

Metallic Set of 6 — Copper, Gold, Metallic Green, Metallic Red, Metallic Turquoise, and Silver.

NUMBER	SIZE	EACH	12/EA
A00045-0166	16 oz (473 ml)	\$40.46	\$36.42

Glitter Set of 6 — Glitter Blue, Glitter Green, Glitter Pink, Glitter Purple, Glitter Red, and Glitter Yellow.

NUMBER	SIZE	EACH	12/EA
A00045-0266	16 oz (473 ml)	\$41.59	\$37.43

For open stock colors, visit DickBlick.com.



Jazz® Gloss Tempera

Jazz dries like a glossy enamel. It makes a great window paint and is excellent for lettering and murals. Thin with water for airbrushing. 16 oz (473 ml) bottles. **Colors can be assorted for quantity pricing.**

NUMBER	COLOR	EACH	12/EA
A00014-2006	Black	\$9.33	\$8.40
A00014-5106	Blue		
A00014-8006	Brown		
A00014-7106	Green		
A00014-4516	Orange		
A00014-3106	Red		
A00014-5236	Ultra Blue		
A00014-6506	Violet		
A00014-1006	White		
A00014-4106	Yellow		

Jazz Gloss Fluorescents

NUMBER	COLOR	EACH	12/EA
A00014-5006	Fluor Blue	\$11.29	\$10.16
A00014-7006	Fluor Green		
A00014-4506	Fluor Orange		
A00014-3056	Fluor Pink		
A00014-6416	Fluor Purple		
A00014-3006	Fluor Red		
A00014-4016	Fluor Yellow		

Jazz Gloss Metallics — 16-oz (473-ml).

NUMBER	COLOR	EACH	12/EA
A00014-9516	Metallic Copper	\$15.97	\$14.38
A00014-9026	Metallic Gold		
A00014-1566	Metallic Pearl		
A00014-9326	Metallic Silver		



Handy Art® Tempera Paint

An economical tempera made with high-quality pigments that are finely ground to provide bright color. They blend easily and dry to an opaque matte finish that won't chip, flake, or crack. Soap and water cleanup. Non-toxic. **Colors can be assorted for quantity pricing.**

COLOR	16 OZ (473 ML)	GALLON (3.78 L)
Black	A00072-2006	A00072-2009
Blue	A00072-5026	A00072-5029
Brown	A00072-8006	A00072-8009
Green	A00072-7006	A00072-7009
Grey	A00072-2506	A00072-2509
Magenta	A00072-3046	A00072-3049
Orange	A00072-4506	A00072-4509
Peach	A00072-4106	A00072-4109
Red	A00072-3006	A00072-3009
Turquoise	A00072-5116	A00072-5119
Violet	A00072-6006	A00072-6009
White	A00072-1006	A00072-1009
Yellow	A00072-4006	A00072-4009
EACH	\$3.13	EACH \$19.69
12/EA	2.82	12/EA 17.72



SARGENT ART



Sargent Art® Art-Time® Washable Tempera

Tested by teachers for reliability, Art-Time Washable Tempera lays down smoothly and won't peel, crack, or separate. Non-toxic. Clean up with water. **Colors can be assorted for quantity pricing.**

COLOR	16 OZ (473 ML)	GALLON (3.78 LITER)
Black	A00116-2006	A00116-2009
Blue	A00116-5006	A00116-5009
Brown	A00116-8016	A00116-8019
Green	A00116-7006	A00116-7009
Magenta	A00116-3036	A00116-3039
Orange	A00116-4506	A00116-4509
Peach	A00116-3346	A00116-3349
Red	A00116-3006	A00116-3009
Turquoise Blue	A00116-5106	A00116-5109
Violet	A00116-6506	A00116-6509
White	A00116-1026	A00116-1029
Yellow	A00116-4006	A00116-4009
EACH	\$2.70	EACH \$16.26
12/EA	2.43	4/EA 14.63

Sargent Art® Art-Time® Washable Fluorescent Tempera

Bold, bright, vivid — and washable! Non-toxic. **Colors can be assorted for quantity pricing.**

COLOR	NUMBER	EACH	12/EA
Fluor Blue	A00115-5246	\$9.70	\$8.73
Fluor Chartreuse	A00115-4916		
Fluor Green	A00115-7276		
Fluor Orange	A00115-4566		
Fluor Pink	A00115-3726		
Fluor Red	A00115-3216		
Fluor Yellow	A00115-4226		

Sargent Art® Art-Time® Washable Glitter Tempera

Add a whole lot of sparkle to your next project with brilliant, opaque glitter paint. Non-toxic. 16 oz (473 ml) bottles. **Colors can be assorted for quantity pricing.**

COLOR	NUMBER	EACH	6/EA
Blue	A00117-5016	\$7.19	\$6.61
Gold	A00117-9016		
Green	A00117-7016		
Magenta	A00117-3046		
Red	A00117-3016		
Silver	A00117-9336		
Violet	A00117-6516		
Yellow	A00117-4016		



Sargent Art® Art-Time® Neon Tempera

Bold, bright, and non-toxic. **Colors can be assorted for quantity pricing.**

COLOR	16 OZ (473 ML)	GALLON (128 OZ)
Black	A00115-2026	A00115-2009
Blue	A00115-5016	A00115-5009
Brown	A00115-8006	A00115-8019
Green	A00115-7016	A00115-7009
Magenta	A00115-3046	A00115-3039
Orange	A00115-4516	A00115-4509
Peach	A00115-3356	A00115-3349
Red	A00115-3016	A00115-3009
Turquoise	A00115-5116	A00115-5109
Violet	A00115-6516	A00115-6509
White	A00115-1026	A00115-1029
Yellow	A00115-4016	A00115-4009
EACH	\$2.67	EACH \$16.16
12/EA	\$2.40	6/EA \$6.16

Sargent Art® Art-Time® Neon Tempera

Bold, bright, and non-toxic. **Colors can be assorted for quantity pricing.**

COLOR	NUMBER	EACH	12/EA
Fluor Blue	A00115-5246	\$9.70	\$8.73
Fluor Chartreuse	A00115-4916		
Fluor Green	A00115-7276		
Fluor Orange	A00115-4566		
Fluor Pink	A00115-3726		
Fluor Red	A00115-3216		
Fluor Yellow	A00115-4226		



Sargent Art® Metallic Tempera

Create rich, metallic faux and patina finishes on wood, paper, or plastic. Non-toxic. **Colors can be assorted for quantity pricing.**

COLOR	NUMBER	EACH	12/EA
Black	A00066-2416	\$9.63	\$8.64
Blue	A00066-5446		
Brown	A00066-9546		
Gold	A00066-9256		
Green	A00066-7546		
Orange	A00066-3056		
Pink	A00066-3726		
Red	A00066-3216		
Violet	A00066-6916		
Yellow	A00066-4226		

Set of 6 — Includes 22 ml (0.75 oz) bottles of Antique Gold, Aztec Gold, Bronze, Copper, Gold, and Silver.

NUMBER	EACH	12/EA
A00118-0069	\$5.93	\$5.34

Chroma® 2 Washable Tempera Paint

Perfect for a wide variety of colorful projects, Chroma 2 delivers strong, vivid color and has a thick, creamy consistency. Excellent color-mixing ability. Soap and water cleanup. Intense and opaque. Non-toxic. **Colors can be assorted for quantity pricing.**

NUMBER	COLOR	EACH	12/EA
A00119-2026	Black	\$6.97	\$6.28
A00119-8006	Brown		
A00119-5626	Cool Blue		
A00119-3716	Cool Red		
A00119-4476	Cool Yellow		
A00119-7046	Green Deep		
A00119-7016	Green Light		
A00119-4516	Orange		
A00119-6006	Purple		
A00119-5116	Turquoise		
A00119-5506	Warm Blue		
A00119-3776	Warm Red		
A00119-4426	Warm Yellow		
A00119-1026	White		

Chroma® Chromatemp Artists' Tempera Paints

Perfect for posters, signs, school projects, and more, Chroma Chromatemp Artists' Tempera Paints are non-toxic and made with rich pigments. Waterbased and intermixable, they are suitable for use on paper, cardboard, and more. These paints are freeze-thaw stable, won't settle or separate in the bottle, and clean up with soap and water. Pearlescent colors are transparent while painting and dry to a smooth, lustrous finish. Fluorescent colors are super bright and non-flaking.

NUMBER	COLOR	EACH	12/EA
A00066-2026	Black	\$6.74	\$6.07
A00066-8006	Brown		
A00066-7016	Green		
A00066-3046	Magenta		
A00066-4516	Orange		
A00066-5016	Phthalo Blue		
A00066-3016	Red		
A00066-5116	Turquoise		
A00066-5136	Ultra Blue		
A00066-6516	Violet		
A00066-1026	White		
A00066-3046	Yellow		

NUMBER	COLOR	EACH	12/EA
A00066-5246	Fluorescent Blue	\$8.38	\$7.54
A00066-7276	Fluorescent Green		
A00066-4566	Fluorescent Orange		
A00066-3726	Fluorescent Pink		
A00066-3216	Fluorescent Red		
A00066-6916	Fluorescent Violet		
A00066-4226	Fluorescent Yellow		

NUMBER	COLOR	EACH	12/EA
A00066-2416	Pearlescent Black	\$8.38	\$7.54
A00066-5446	Pearlescent Blue		
A00066-9546	Pearlescent Copper		
A00066-9256	Pearlescent Gold		
A00066-7546	Pearlescent Green		
A00066-3056	Pearlescent Magenta		
A00066-3726	Pearlescent Red		
A00066-9376	Pearlescent Silver		
A00066-5126	Pearlescent Turquoise		
A00066-6906	Pearlescent Violet		
A00066-1606	Pearlescent White		
A00066-4866	Pearlescent Yellow		

RICHESON



Set of 6 Cool Colors

Set of 8 Multicultural Colors

Small Cakes, Set of 6 Fluorescent Colors

Set of 9 Colors

Richeson® Tempera Cakes in Trays

Vibrant tempera paint cakes are packaged in heavy-duty, reusable, muffin-style trays. Low waste and low mess — perfect for the classroom! Cakes measure 2-1/4" Dia x 11/16" thick.

Set of 6 Secondary Colors — Violet, Cobalt Blue, Cerise, Vermilion, Leaf Green, and Turquoise.

NUMBER	EACH	12/EA
A00054-2069	\$15.70	\$14.15

Set of 6 Warm Colors — Yellow, Orange, Brilliant Red, Gamboge, Vermillion, and Purple.

NUMBER	EACH	12/EA
A00054-1039	\$15.70	\$14.15

Set of 6 Cool Colors — Blue, Turquoise, Leaf Green, Violet, Cobalt Blue, and Green.

NUMBER	EACH	12/EA
A00054-1049	\$15.70	\$14.15

Set of 8 Multicultural Colors — Black, Burnt Umber, Burnt Sienna, Peach, Light Brown, Sienna Brown, Yellow Ochre, and White cakes plus a brush.

NUMBER	EACH	12/EA
A00054-1019	\$24.60	\$22.15

Set of 9 Colors — Black, Blue, Green, Orange, Crimson, White, Turquoise, Purple, and Yellow.

NUMBER	EACH	12/EA
A00054-1099	\$20.75	\$18.68

Richeson® Tempera Small Cakes

These bright cakes are packaged in heavy-duty, reusable, muffin-style trays. Offering low waste and low mess, they're perfect for the classroom. Cakes measure 1-11/16" Dia and 5/8" thick.

Set of 6 Fluorescent Colors — Yellow, Pink, Blue, Red, Green, and Orange.

NUMBER	EACH	12/EA
A00054-3069	\$21.99	\$19.79

Assorted Fluorescent Refill of 6 — 1-11/16" Dia x 5/8" thick cakes in Yellow, Pink, Blue, Red, Green, and Orange.

NUMBER	EACH	12/EA
A00124-1006	\$22.71	\$20.44

Richeson Tempera Cakes w/ Rack



Richeson® Tempera Cakes with Rack

This heavy-duty rack makes classroom storage a breeze. It includes 12, 8-color sets of student-grade tempera in reusable trays. Each set includes Red, Yellow, Blue, Green, Purple, Brown, Black, and White tempera cakes and a brush. Rack measures 20-1/2"H x 13"W x 7-1/2"D. Empty racks and replacement trays also sold separately.

NUMBER	DESCRIPTION	EACH	12/EA
A00054-1209	Rack w/12 Filled Trays	\$252.45	\$227.25
A03413-1012	Rack Only	71.39	64.27
A03413-1008	Empty Replacement Tray	6.62	5.94

Richeson Tempera Mini Cakes w/ Rack



D Set of 9 Standard Colors — Blue, Yellow, Red, Green, Orange, Purple, White, Black, and Turquoise.

NUMBER	EACH	6/EA
A00073-1029	\$12.98	\$11.69

E Set of 9 Multicultural Colors — Black, Van Dyke Brown, Burnt Umber, Burnt Sienna, Sienna Brown, Light Brown, Yellow Ochre, Peach, and White.

NUMBER	EACH	6/EA
A00073-1009	\$12.98	\$11.69

F Set of 9 Metallic Colors — Gold, Copper, Mirror, Charcoal, Blue, and Orchid.

NUMBER	EACH	6/EA
A00070-0909	\$30.65	\$27.56

G Set of 9 More Colors — Burnt Sienna, Burnt Umber, Cerise, Cobalt Blue, Gamboge, Leaf Green, Vermillion, Violet, and Yellow Ochre.

NUMBER	EACH	6/EA
A00073-1069	\$12.98	\$11.69

For Richeson Tempera Mini Cake Refills, visit DickBlick.com.

Richeson® Tempera Mini Cakes

Mini Cakes make classroom distribution easier than ever. Cakes measure 1-5/8" Dia x 5/16" thick. Each color below is sold in a package of six. Sets come in reusable black plastic trays. Colors can be assorted for quantity pricing.

NUMBER	COLOR	EACH	6/EA
A00073-2001	Black	\$7.15	\$6.43
A00073-5021	Blue	7.15	6.43
A00073-8051	Brown	7.15	6.43
A00073-7001	Green	7.15	6.43
A00073-4501	Orange	7.15	6.43
A00073-6001	Purple	7.15	6.43
A00073-3021	Red	7.15	6.43
A00073-5111	Turquoise	7.15	6.43
A00073-6511	Violet	7.15	6.43
A00073-1021	White	7.15	6.43
A00073-4021	Yellow	7.15	6.43

A Set of 6 Standard Colors — Blue, Yellow, Red, Green, Black, and White.

NUMBER	EACH	6/EA
A00073-1019	\$8.68	\$7.77

B Set of 6 Metallic Colors — Gold, Copper, Mirror, Charcoal, Blue, and Orchid.

NUMBER	EACH	6/EA
A00070-0609	\$24.26	\$21.84

C Set of 6 Fluorescent Colors — Fluorescent Yellow, Fluorescent Pink, Fluorescent Blue, Fluorescent Red, Fluorescent Green, and Fluorescent Orange.

NUMBER	EACH	6/EA
A00073-1059	\$18.49	\$16.66

NUMBER	EACH	6/EA
A00070-1006	\$14.36	\$12.92

BLICK® tempera cakes



Blick® Tempera Cakes

Blick Tempera Cakes provide concentrated, brilliant color with no spills, no waste, and no overload of color. Simply moisten with a brush and paint! Compared to liquid tempera, they are easier to share and store in a classroom. Extra-large size: 2-1/4" Dia x 3/4" thick. Approximately 4 oz (118 ml) each. Colors can be assorted for quantity pricing.

NUMBER	COLOR	EACH	6/EA	NUMBER	COLOR	EACH	6/EA
A00001-2000	Black	\$2.25	\$2.03	A00001-2406	Lemon	\$2.25	\$2.03
A00001-5025	Blue	2.25	2.03	A00001-4500	Orange	2.25	2.03
A00001-3726	Brilliant Red	2.25	2.03	A00001-3350	Peach	2.25	2.03
A00001-8050	Brown	2.25	2.03	A00001-6000	Purple	2.25	2.03
A00001-8716	Burnt Sienna	2.25	2.03	A00001-3023	Red	2.25	2.03
A00001-3720	Cerise	2.25	2.03	A00001-5110	Turquoise	2.25	2.03
A00001-5180	Cobalt Blue	2.25	2.03	A00001-3286	Vermillion	2.25	2.03
A00001-6510	Grape	2.25	2.03	A00001-1023	White	2.25	2.03
A00001-7000	Green	2.25	2.03	A00001-4023	Yellow	2.25	2.03
A00001-7150	Leaf Green	2.25	2.03	A00001-4046	Yellow Ochre	2.25	2.03



Rack also fits Blick Tempera Cakes Set of 6

Richeson® Small Tempera Rack with 6 Sets

Comes filled with six 6-Color Sets in heavy-duty trays. Each set includes Black, Blue, Green, Red, White, and Yellow cakes plus a brush. Cakes measure 2-1/4" x 11/16". Rack is 17-1/2"H x 10"W x 7-1/2"D.

NUMBER	EACH	12/EA
A00054-1009	\$127.45	\$114.70
A00054-2069	\$15.70	\$14.15



Set of 6 with Tray

Set of 6 with Tray — Red, Yellow, Green, Blue, Black, and White.

NUMBER	EACH	12/EA
A00001-0069	\$10.95	\$9.35

Set of 9 — Red, Blue, Yellow, Green, Black, White, Orange, Purple, and Turquoise. Tray not included.

NUMBER	EACH	12/EA
A00001-1019	\$14.99	\$13.49

Primary Colors Refill Set of 6 — Red, Yellow, Blue, Green, Black, and White.

NUMBER	EACH	12/EA
A00001-1029	\$9.70	\$8.75

Secondary Colors Refill Set of 6 — Cerise, Cobalt Blue, Leaf Green, Turquoise, Vermillion, and Violet.

NUMBER	EACH	12/EA
A00001-1039	\$9.70	\$8.75



Richeson® Plastic Muffin Pans

These economical, vacuum-formed white plastic pans are ideal for mixing or holding lots of paint.

NUMBER	DESCRIPTION	SIZE	EACH	12/EA
A03037-1001	2 Wells	3-3/8" x 7-1/4"	\$1.56	\$1.39
A03037-1002	4 Wells	7-1/8" x 7-1/8"	2.44	2.19
A03037-1003	6 Wells	7-1/4" x 11"	2.74	2.30
A03037-1009	9 Wells	10-3/4" x 10-3/4"	4.94	4.45



Prang® Tempera Cake Set
This complete tempera kit includes a plastic tray with water wells, a paintbrush, and nine tempera cakes. Each cake is 1-1/2"Sqr.

NUMBER	EACH	12/EA
A00008-0099	\$20.29	\$16.97



Alphacolor® Biggie Cakes
Brilliant, opaque watercolor tempera in semi-moist cakes. Biggie size is 2"Sqr x 1/2" thick. In individual vacuum-formed plastic trays with lids.

Biggie 8-Color Set with Tray — Assorted colors.

NUMBER	EACH	12/EA
A00006-0099	\$22.20	\$19.10



Biggie 12-Color Set without Tray — Assorted colors.

NUMBER	EACH	12/EA
A00006-0129	\$37.06	\$33.34



Alphacolor® Studio Cakes
Opaque tempera cakes. Molded plastic palette tray has a lid and watercolor brush. Contains one each: Black, Blue, Brown, Green, Red, Orange, White, and Yellow. Each is 1-1/4"W x 1"D x 1/4" thick.

NUMBER	EACH	12/EA
A00005-0089	\$16.30	\$14.67



A-C Richeson® Semi-Moist Tempera Cake Sets

Great for classrooms and group art projects, these tempera cake sets feature vibrant, bright colors that mix beautifully. Cakes easily wet with water. Non-toxic.

A Tempera Rack with 12 Sets — This storage rack comes filled with 12, 8-Color Primary Sets in heavy-duty trays. Contents listed below. Rack measures 20-1/2"H x 13"W x 7-1/2"D.

NUMBER	EACH	6/EA
A00099-1039	\$338.00	\$305.00

B Small Square 19-Color Set with Tray and Lid — Cakes measure 1-1/4"W x 1"D x 1/2" thick. Set includes Blue, Yellow, Red, Green, Orange, Purple, Brown, White, Black, Hot Pink Deep, Ultramarine, Light Green, Peach, Sky Blue, Yellow Ochre, Burnt Sienna, Warm Yellow, Violet, and Turquoise.

NUMBER	EACH	6/EA
A00099-1029	\$39.63	\$35.67

C 8-Color Primary Set with Heavy-Duty Tray — This tray fits in the Tempera Rack (sold separately). Cakes measure 1-5/8"W x 1-7/8"D x 1/2" thick. Set includes Blue, Yellow, Red, Green, Orange, Brown, White, and Black.

NUMBER	EACH	6/EA
A00099-1049	\$28.05	\$25.25

Richeson® Semi-Moist Tempera Cake Palettes

Create your own Semi-Moist Tempera Cake set by filling an empty palette with colors of your choosing (sold separately). Each pack includes six empty larger-size butcher trays with spots for 1-5/8"W x 1-7/8"D x 1/2" thick cakes.

Pack of Six Empty 8-Color Trays with Lids

NUMBER	EACH	12/EA
A03476-1008	\$19.99	\$17.99

Pack of Six Empty 12-Color Trays with Lids

NUMBER	EACH	12/EA
A03476-1012	\$25.78	\$23.16



Richeson® Semi-Moist Tempera Cakes

Richeson Semi-Moist Tempera Cakes feature vibrant, bright colors that mix beautifully. Tempera Cakes are great for classrooms and group art projects. Paint is AP certified non-toxic. Cakes are 1-5/8"W x 1-7/8"D x 1/2" thick (unless noted). **Colors can be assorted for quantity pricing.**

NUMBER	COLOR	EACH	12/EA
A00099-2020	Black	\$3.51	\$3.16
A00099-5010	Blue	3.51	3.16
A00099-8010	Brown	3.51	3.16
A00099-8710	Burnt Sienna	3.51	3.16
A00099-7020	Green	3.51	3.16
A00099-3290	Hot Pink Deep	3.51	3.16
A00099-7010	Light Green	3.51	3.16
A00099-4510	Orange	3.51	3.16
A00099-1120	Peach	3.51	3.16
A00099-6000	Purple	3.51	3.16
A00099-3010	Red	3.51	3.16
A00099-5070	Sky Blue	3.51	3.16
A00099-5110	Turquoise	3.51	3.16
A00099-5120	Ultramarine	3.51	3.16
A00099-6510	Violet	3.51	3.16
A00099-4420	Warm Yellow	3.51	3.16
A00099-1020	White	3.51	3.16
A00099-4010	Yellow	3.51	3.16
A00099-4040	Yellow Ochre	3.51	3.16

Small Square 8-Color Set with Tray — Cakes measure 1-1/4"W x 1"D x 1/4" thick. Set includes Blue, Yellow, Red, Green, Orange, Brown, White, and Black in a black tray.

NUMBER	EACH	12/EA
A00099-1108	\$23.99	\$21.61

Small Square 8-Color Refill Pack — Replacement cakes in the same colors as the Small Square 8-Color Set. No tray.

NUMBER	EACH	12/EA
A00099-1008	\$21.62	\$19.45

3-Color Refill Pack — Blue, Yellow, and Red. No tray.

NUMBER	EACH	12/EA
A00099-1003	\$10.66	\$9.59

8-Color Primary Set with Tray — Blue, Yellow, Red, Green, Orange, Brown, White, and Black in a black tray.

NUMBER	EACH	12/EA
A00099-1009	\$28.29	\$25.46

8-Color Secondary Set with Tray — Purple, Hot Pink Deep, Ultramarine, Light Green, Peach, Sky Blue, Yellow Ochre, and Burnt Sienna in a black tray.

NUMBER	EACH	12/EA
A00099-1019	\$28.29	\$25.46

8-Color Refill Pack — Replacement cakes in the same colors as the 8-Color Primary Set. No tray.

NUMBER	EACH	12/EA
A00099-1001	\$25.45	\$22.91

12-Color Set with Tray — Blue, Yellow, Red, Green, Orange, Brown, White, Black, Hot Pink Deep, Peach, Violet, and Turquoise in a black tray.

NUMBER	EACH	12/EA
A00099-1112	\$33.49	\$30.15

12-Color Refill Pack — Replacement cakes in the same colors as the 12-Color Set. No tray.

NUMBER	EACH	12/EA
A00099-1012	\$33.73	\$30.35



Standard Size Playcolor® Tempera Paint Sticks

Simple to use — no water, paintbrushes, or cups required. Playcolor sticks are great for painting on paper, cardboard, wood, and more. Just uncap, twist, and paint!

Standard Size Set of 12 — White, Yellow, Orange, Red, Pink, Leaf Green, Dark Green, Sky Blue, Dark Blue, Purple, Brown, and Black.

NUMBER	EACH	6/EA
A00061-2112	\$19.50	\$17.27



Standard Size Set of 6 Metallic — Silver, Gold, Pink, Blue, Purple, and Green.

NUMBER	EACH	6/EA
A00061-2006	\$17.48	\$15.73

Standard Size Set of 72 Metallic — 12 each of Silver, Gold, Pink, Blue, Purple, and Green.

NUMBER	EACH	6/EA
A00061-2072	\$183.30	\$164.97

Standard Size Set of 6 Fluorescent — Fluorescent Yellow, Fluorescent Orange, Fluorescent Pink, Fluorescent Green, Fluorescent Purple, and Fluorescent Blue.

NUMBER	EACH	6/EA
A00061-2069	\$17.48	\$15.73



Standard Size Set of 144 — 12 each of White, Yellow, Orange, Red, Pink, Leaf Green, Dark Green, Sky Blue, Dark Blue, Purple, Brown, and Black.

NUMBER	EACH	6/EA
A00061-2144	\$225.87	\$203.28



Pocket Size Set of 144 — 12 each of White, Yellow, Orange, Red, Pink, Leaf Green, Dark Green, Sky Blue, Dark Blue, Purple, Brown, and Black.

NUMBER	EACH	6/EA
A00061-1144	\$291.10	\$261.99

Helpful for individuals with special needs.



Set of 12

Kwik Stix™

Non-toxic and completely safe for kids, Kwik Stix help young artists unleash their creativity with unlimited potential. These versatile, solid tempera paint sticks work well on paper, poster board, cardboard, wood, and more. Dries in less than 90 seconds.

Set of 12 — Red, Green, Yellow, Navy Blue, Brown, Black, Purple, Orange, Pink, Light Green, Light Blue, and White.

NUMBER	EACH	6/EA
A00082-1012	\$12.95	\$11.65

Set of 96 — Eight each of Red, Green, Yellow, Navy Blue, Brown, Black, Purple, Orange, Pink, Light Green, Light Blue, and White.

NUMBER	EACH	6/EA
A00082-1096	\$89.79	\$80.79

Set of 144 — 12 each of Red, Green, Yellow, Navy Blue, Brown, Black, Purple, Orange, Pink, Light Green, Light Blue, and White.

NUMBER	EACH	6/EA
A00082-1144	\$136.05	\$122.45



Assorted Class Pack, 144 Sticks



Creativity Street Glide-On Tempera Sticks Sets

Easily create colorful works of art! These 5 g sticks can be applied directly to paper, chipboard, plastic, and more for no-mess creating. They won't bleed through, wrinkle, or tear paper. This set includes Red, Pink, Orange, Yellow, Dark Green, Light Green, Light Blue, Dark Blue, Purple, White, Brown, and Black.

NUMBER	EACH	6/EA
A00125-1009	\$11.58	\$10.43



Set of 144



Set of 72 Neon

Set of 24 — 12 classic colors, six Neon colors, and six Metallic colors.

NUMBER	EACH	6/EA
A00082-1124	\$29.99	\$26.99

Neon Set of 72 — 12 each of Yellow, Orange, Blue, Pink, Purple, and Green.

NUMBER	EACH	6/EA
A00082-1072	\$73.50	\$66.15

Metalix Set of 72 — 12 each of Gold, Silver, Blue, Purple, Pink, and Green.

NUMBER	EACH	6/EA
A00082-1172	\$73.50	\$66.15



Sargent Art® Tempera Paint Sticks

Made with fast-drying paint. Use on paper, cardboard, wood, and more. Non-toxic.

Assorted Class Pack, 144 Sticks — Includes 12 sticks each of the colors in the Assorted Set of 12.

NUMBER	EACH	6/EA
A00120-1144	\$144.23	\$129.77

Neon & Metallic Class Pack, 144 Sticks — Add some extra flair with these bright neons and shimmering metallics. Pack includes 72 Neon sticks in six different colors and 72 Metallic sticks in six different colors.

NUMBER	EACH	6/EA
A00120-2144	\$144.23	\$129.77

Assorted Set of 12 — Black, Brown, Dark Blue, Green, Light Blue, Light Green, Orange, Pink, Red, Violet, White, and Yellow.

NUMBER	EACH	12/EA
A00120-1012	\$13.93	\$12.29

Neon & Metallic Set of 12 — Make your projects pop. Set includes six Neon colors and six Metallic colors.

NUMBER	EACH	12/EA
A00120-1112	\$13.93	\$12.29

Snazaroo™ Face Paints

Hypo-allergenic, non-toxic, and fragrance-free. Waterbased for easy removal with water and soap. Colors can be assorted for quantity pricing.

0.6 oz (18 ml) Pans

COLOR	NUMBER	EACH	5/EA
Black	A00205-2020		
Bright Pink	A00205-3710		
Bright Red	A00205-3070		
Bright Yellow	A00205-4290		
Grass Green	A00205-7240		
Light Brown	A00205-8010		
Light Gray	A00205-2510		
Orange	A00205-4510		
Purple	A00205-6000		
Sky Blue	A00205-5070		
Turquoise	A00205-5110		
White	A00205-1020		

Metallic 0.6 oz (18 ml) Pans

COLOR	NUMBER	EACH	5/EA
Copper	A00205-9500		
Gold	A00205-9010		
Silver	A00205-9330		

Pebeo® Arti' Stick Window Cling Paint

Just squeeze your design onto a plastic sheet, let dry for 24 hours, peel off, and stick on any non-porous surface. Colors can be assorted for quantity pricing.

16.9 oz (500 ml) Bottles

COLOR	NUMBER	EACH	10/EA
Black	A00700-2025		
Bright Pink	A00700-3065		
Brown	A00700-8005		
Dark Blue	A00700-5035		
Dark Green	A00700-7035		
Gold Sparkles	A00700-9005		
Light Blue	A00700-5025		
Light Green	A00700-7015		
Orange	A00700-4505		
Red	A00700-3005		
White	A00700-1015		
Yellow	A00700-4005		

16.9 oz (500 ml) Outliners

COLOR	NUMBER	EACH	10/EA
Black	A00700-2095		
Gold	A00700-9095		

Arti' Stick Teacher's Kit — Kit includes one 16.9 oz (500 ml) bottle each of White, Orange, Gold Sparkle, Brown, Light Green, Light Blue, Red, Yellow, Black Outliner, and Gold Outliner; 20 oz (25 ml) refillable bottles; nine pages of patterns, including the solar system; 30 acetate sheets; teacher lesson plans; and instruction guide.

NUMBER	EACH
A00700-1109	\$167.04

For Pebeo® Arti' Stick Patterns, visit DickBlick.com.

Palmer® Face Paint

Children can explore, experiment, and develop their creativity with Palmer's lively face paint colors. Non-toxic and washable, these colors are safe for use on skin. Colors can be assorted for quantity pricing.

COLOR	2 oz (59 ml)	8 oz (237 ml)
Black	A00201-2004	A00201-2005
Blue	A00201-5004	A00201-5005
Brown	A00201-8004	A00201-8005
Green	A00201-7004	A00201-7005
Magenta	A00201-3044	A00201-3045
Orange	A00201-4504	A00201-4505
Pink	A00201-3054	A00201-3055
Purple	A00201-6004	A00201-6005
Red	A00201-3004	A00201-3005
Turquoise	A00201-5114	A00201-5115
White	A00201-1004	A00201-1005
Yellow	A00201-4004	A00201-4005

Kwik Stix® Face Stix

Brightly-colored face paint sticks apply easily, dry rapidly, and will not smudge. Non-toxic, gluten-free, and specially formulated to be suitable for the most sensitive skin. Remove with soap and water.

NUMBER	DESCRIPTION	EACH	6/EA
A67157-1001	Adventure, Set of 3	\$9.07	\$8.17
A67157-1002	Fantasy, Set of 3	9.07	8.17
A67157-1003	Halloween, Set of 3	9.07	8.17
A67157-1004	Jungle, Set of 3	9.07	8.17
A67157-1005	Monochrome, Set of 3	9.07	8.17

Crayola® Washable Finger Paint

Extra bright, creamy-smooth, and completely washable from hands and most clothing. Won't crack or rub off finished artwork. Colors can be assorted for quantity pricing.

COLOR	16 oz (473 ml)	32 oz (946 ml)
Black	A00102-2006	A00102-2007
Blue	A00102-5006	A00102-5007
Brown	A00102-8006	A00102-8007
Green	A00102-7006	A00102-7017
Orange	A00102-4506	A00102-4507
Red	A00102-3006	A00102-3007
Violet	A00102-6506	A00102-6507
White	A00102-1006	A00102-1007
Yellow	A00102-4006	A00102-4007

Set of 3 Primary Colors — Red, Yellow, and Blue. 8 oz (236 ml) bottles.

NUMBER	EACH	12/EA
A00102-1189	\$11.96	\$10.76

Set of 3 Secondary Colors — Violet, Green, and Orange. 8 oz (236 ml) bottles.

NUMBER	EACH	12/EA
A00102-1089	\$11.96	\$10.76

Pacon® Art Street Finger Paint Paper

This high-quality 50 lb white paper is coated on both sides — ideal for finger paints, tempera, and airbrushing. The smooth, non-absorbent surface resists running, smearing, and bleeding. Recycled.

NUMBER	SIZE	EACH	12/EA
A10068-1026	11" x 16", 50 Sheets	\$4.78	\$4.30
A10068-1028	16" x 22", 100 Sheets	10.10	9.09
A10068-1029	16" x 22", 500 Sheets	49.29	44.35
A10068-1021	16"W x 100 ft Roll	10.94	9.85

Richeson® Powdered Tempera Paint

Simply mix Richeson Powdered Tempera Paint with water and have the exact amount of tempera paint you need for your project. Plus you control the viscosity of the paint by how much water you add. Colors can be assorted for quantity pricing.

1 lb (473 ml) Jars

COLOR	NUMBER	EACH	12/EA
Black	A00069-2021		
Blue	A00069-5011		
Brown	A00069-8001		
Green	A00069-7011		
Leaf Green	A00069-7151		
Orange	A00069-4511		
Purple	A00069-6001		
Red	A00069-3011		
Sky Blue	A00069-5071		
Turquoise	A00069-5111		
White	A00069-1021		
Yellow	A00069-4011		

Fluorescent Colors, 0.5 lb (236.5 ml) Jars

COLOR	NUMBER	EACH	12/EA
Fluorescent Blue	A00069-5245		
Fluorescent Green	A00069-7275		
Fluorescent Orange	A00069-4565		
Fluorescent Pink	A00069-3725		
Fluorescent Red	A00069-3215		
Fluorescent Yellow	A00069-4225		



Crafty Dab™ Poster Paint Marker Set
Smooth, easy-flow, no-mess paint is ideal for posters, signs, banners, and other large surface coverage. The colors are washable and will not crack, peel, or flake. The non-leaking, spring-valve applicator will not dry out. Set of 10, 1.6 oz (48 ml) poster colors.

NUMBER	EACH	8/EA
A22882-0109	\$26.05	\$23.46



Crafty Dab™ Window Writer Set
A fun, unique way to add special messages to windows and mirrors. There are no brushes or water required, and the color won't crack or flake off — just unscrew the cap! Includes 10 non-toxic 1.6 oz (48 ml) colors. Cleans easily with water or glass cleaner. For open stock, visit DickBlick.com.

NUMBER	EACH	8/EA
A02982-0109	\$26.05	\$23.45



Set of 6 Rainbow Colors



Set of 6 Brilliant Colors



Set of 5 Royal Shimmer Colors



Set of 72 Class Pack



Set of 25 Class Pack



Do-A-Dot Art™ Markers

Do-A-Dot markers have large, round, spongy tips that young artists can apply in various patterns to form images. No-drip, no-spill markers eliminate the need for messy paint cups, brushes, and water dishes. 2.5 oz (74 ml). For set colors, visit DickBlick.com.

Standard Marker Sets

NUMBER	DESCRIPTION	EACH
A67104-1049	Set of 4 Rainbow Colors	\$12.99
A67104-1350	Set of 5 Metallic Colors	18.99
A67104-1150	Set of 5 Neon Colors	18.99
A67104-1050	Set of 5 Royal Shimmer Colors	18.99
A67104-1250	Set of 5 Ultra Bright Colors	18.99
A67104-1060	Set of 6 Brilliant Colors	18.99
A67104-2060	Set of 6 Rainbow Colors	18.99

Class Packs

NUMBER	DESCRIPTION	EACH
A67104-1025	Set of 25	\$65.99
A67104-1072	Set of 72	180.00

Mini Marker Sets

NUMBER	DESCRIPTION	EACH
A67104-3060	Set of 6 Jewel Colors	\$18.99
A67104-4060	Set of 6 Island Colors	18.99

Scented Markers

NUMBER	DESCRIPTION	EACH
A67104-1009	Set of 6 Juicy Fruit	\$18.99
A67104-1019	Set of 6 Ice Cream Dreams	18.99



Set of 6 Juicy Fruit Scented Markers



Set of 6 Ice Cream Dreams Scented Markers



Set of 6 Mini Marker, Jewel Colors



Liqui-Mark Washable Paint Sets

Perfect for kids of any age, these non-toxic sets feature bright colors and easily wash off skin and most fabrics with soap and water.

NUMBER	DESCRIPTION	EACH	12/EA
A01800-1089	Set of 8	\$2.28	\$2.05
A01800-1169	Set of 16	3.50	3.15



Richeson Art Paint Sets

Vibrant, waterbased, student grade art paints ideal for arts and crafts, school projects, and more. Paints come in heavy duty black trays. Each pan holds 0.4 oz of paint.

NUMBER	DESCRIPTION	EACH	6/EA
A01798-1039	3 Colors	\$5.50	\$4.95
A01798-1069	6 Colors	8.86	7.98
A01798-1096	9 Colors	13.70	12.34
A01798-1159	15 Colors	27.55	24.80
A01798-1169	6 Fluorescent Colors	18.65	16.79



Camellia Student Watercolor Set

These transparent colors behave like professional watercolors. Easy to lay down in washes, they give students greater control over the painting process. Set of 18 pans comes in a tin with multiple mixing trays and a quality brush.

NUMBER	EACH	10/EA	53.36
A01709-0189	\$5.95		

Richeson Opaque Watercolor Pan Sets

These premium-quality opaque student watercolors are priced for schools or workshops. Pans measure 1-1/2"Dia. They are set in a plastic tray featuring a hinged cover with built-in mixing wells. A brush is included in all sets. For colors, visit DickBlick.com.

NUMBER	DESCRIPTION	EACH	12/EA
A00380-0089	8 Colors	\$6.20	\$5.58
A00380-0229	22 Colors	14.56	13.07
A00380-1609	12 Pearlescent	10.96	9.87



Sargent Art Supreme Series Watercolor Cake Sets

Perfect for classrooms, these watercolor cakes respond instantly to a wet brush, are easy to transport and distribute, and won't spill. Vibrant, bright colors. Non-toxic. For set colors, visit DickBlick.com.

NUMBER	SET	EACH	12/EA
A01666-1169	Set of 16	\$5.99	\$5.41
A01666-1189	Set of 18	8.45	7.59
A01666-1249	Set of 24	12.78	11.73
A01666-1369	Set of 36	10.50	9.46



Richeson Collegiate Semi-Moist Watercolors

Brilliant, intense, rich semi-moist colors that clean up easily with water.

NUMBER	COLOR	EACH	12/EA
A01679-5010	Blue	\$4.36	\$3.92
A01679-9500	Copper	4.36	3.92
A01679-9010	Gold	4.36	3.92
A01679-9160	Gold Deep	4.36	3.92
A01679-7010	Green	4.36	3.92
A01679-7020	Light Green	4.36	3.92
A01679-1100	Mirror	4.36	3.92
A01679-6420	Orchid	4.36	3.92
A01679-2580	Pewter	4.36	3.92
A01679-3060	Pink	4.36	3.92
A01679-3010	Red	4.36	3.92
A01679-9330	Silver	4.36	3.92
A01679-4010	Yellow	4.36	3.92

Metallic Set of 12 — Pewter, Mirror, Yellow, Gold, Gold Deep, Copper, Green, Light Green, Blue, Pink, Orchid, and Red, plus a synthetic round brush.

NUMBER	EACH	12/EA
A01679-1129	\$16.16	\$14.54

Matte Set of 12 — Yellow, Yellow Ochre, Orange, Red, Crimson, Magenta, Emerald, Hooker's Green, Ultramarine, Phthalo Blue, Burnt Sienna, and Black.

NUMBER	EACH	6/EA	14.54
A01678-1129	\$16.16		



NEW! Faber-Castell Watercolor Art for Beginners Kit

This 17-piece set features the perfect blend of high-quality supplies for learning watercolor techniques. For set contents, visit DickBlick.com.

NUMBER	EACH	6/EA
A01681-1709	\$13.99	\$12.59

A-C Crayola Educational Watercolors

Each brilliant color retains its richness without muddying or fading. Sets are packaged in durable white plastic boxes with divided lids for mixing. Brush included. Oval pans measure 1" x 1 1/4".

A 8-Color Set — Red, Orange, Yellow, Blue, Violet, Green, Brown, and Black. Oval half pans with #7 brush.

NUMBER	EACH	36/EA
A00309-1029	\$5.14	\$4.62

8-Color Mixing Set — Red-Violet, Red-Orange, 2 Primary Yellows, Turquoise, Blue-Violet, Black, and White. Oval half pans with #7 brush.

NUMBER	EACH	36/EA
A00309-1109	\$5.14	\$4.62

B 16-Color Set — Same as 8-Color Set plus White, Red-Orange, Yellow-Orange, Yellow-Green, Turquoise Blue, Blue-Green, Blue-Violet, and Red-Violet. Oval half pans with #7 brush.

NUMBER	EACH	36/EA
A00309-0009	\$9.89	\$8.90

C Classpack — Includes 24, 8-Color Sets described above, plus 12, 8-count oval pan refills.

NUMBER	EACH	3/EA
A00309-1036	\$181.81	\$163.63

Crayola Refills

Each refill contains one color per box. Oval pans are 1" x 1-1/4". Package of six, one color.

NUMBER	COLOR	NUMBER	COLOR
A00309-2007	Black	A00309-3387	Red-Orange
A00309-5007	Blue	A00309-6727	Red-Violet
A00309-5397	Blue-Violet	A00309-5117	Turquoise
A00309-8007	Brown	A00309-6507	Violet
A00309-7007	Green	A00309-1047	White
A00309-4507	Orange	A00309-4007	Yellow
A00309-3007	Red		

D-E Crayola Artista II Semi-Moist Watercolors

D 8-Color Set — Black, Brown, Green, Orange, Blue, Red, Yellow, and Violet. Brush included.

NUMBER	EACH	12/EA
A01701-0089	\$3.29	\$2.96

E 16-Color Set — Brown, Yellow, Orange, Red, Violet, Blue, Green, Black, Yellow-Orange, Red-Orange, Red-Violet, Blue-Violet, Blue-Green, Yellow-Green, Turquoise, and White. Brush included.

NUMBER	EACH	12/EA
A01701-0169	\$5.09	\$4.58

F-G Crayola Washable Watercolors

Normal laundering completely removes paint from 95% of fabrics commonly used in children's clothing. Brush included.

NUMBER	DESCRIPTION	EACH	6/EA
A00307-1039	F 8-Color Square Set	\$3.19	\$2.87
A00307-1009	16-Color Oval Set	5.13	4.62
A00307-0249	G 24-Color Oval Set	6.94	6.25

H Crayola Silly Scents Watercolor 8-Color Set

These watercolors smell like food! This set includes one paintbrush and eight scented watercolors in Root Beer, Lemon, Blueberry, Marshmallow, Grape, Cherry, Green Apple, and Orange. Safe and non-toxic.

NUMBER	EACH	12/EA
A01785-1089	\$3.74	\$3.37



Crayola Jumbo Washable 4-Color Set

The large pans in this set are great for beginners. Includes brush. Refill pans available.

NUMBER	DESCRIPTION	EACH	6/EA
A00307-1029	4-Color Set	\$5.12	\$4.60
A00307-1019	4-Color Refill	3.42	3.08



A



B



C



D



E



F



G



H



Crayola Art Smocks

My First Art Smock — Washable and reusable for hours of worry-free, creative play, it features long sleeves with elastic cuffs and adjustable hook-and-loop straps. 36-1/2"W (including sleeves) x 18"L. For wee artists 12 months and older.

NUMBER	EACH	12/EA
A03471-1003	\$7.69	\$6.92

Creativity Smock — This colorful smock has long sleeves and pockets for storing supplies. Durable, washable, and wipes clean. Adjustable Velcro closure. Measures approximately 17"W x 18-1/2"L and fits most ages 3-6.

NUMBER	EACH	12/EA
A03471-1002	\$9.67	\$8.70

PRANG®



A-B Prang® Washable Watercolor Sets

Designed for early childhood learning and younger students, Prang's semi-moist, washable watercolors are easy to clean from skin and clothing. Brush included.

NUMBER	SET	EACH	12/EA
A00350-1009	A 8-Color Oval	\$3.18	\$2.86
A00350-1019	B 16-Color Oval	4.36	4.05

C-D Prang® Washable Glitter and Metallic Watercolor Sets

Sets include a brush with an easy-grip wood handle. Oval half pans.

NUMBER	SET	EACH	12/EA
A00350-9000	C 8-Color Metallic	\$3.53	\$3.18
A00350-9008	D 8-Color Glitter	3.53	3.18

E Prang® Washable Watercolor Class Pack

Includes 36, 8-color sets of Washable Watercolor in assorted styles: 12 Classic sets, 12 Glitter sets, and 12 Metallic sets.

NUMBER	EACH	6/EA
A00350-0369	\$134.50	\$121.05

F Faber-Castell® Connector Watercolors

These paints offer excellent opacity and mix together easily. Kids can connect pans together in playful ways.

Colors can be assorted for quantity pricing.

NUMBER	SET	EACH	12/EA
A01771-1012	12 Colors	\$13.82	\$12.44
A01771-1024	24 Colors	25.86	24.57

Refill Pans

NUMBER	COLOR	EACH	10/EA
A01771-2012	Black	\$1.61	\$1.55
A01771-5108	Blue Green	1.61	1.55
A01771-5036	Dark Blue	1.61	1.55
A01771-8031	Dark Brown	1.61	1.55
A01771-5027	Light Blue	1.61	1.55
A01771-8001	Light Brown	1.61	1.55
A01771-3044	Magenta	1.61	1.55
A01771-4532	Orange	1.61	1.55
A01771-3023	Red	1.61	1.55
A01771-4201	Yellow	1.61	1.55
A01771-4029	Yellow Green	1.61	1.55
A01771-6505	Violet	1.61	1.55

G Richeson® Semi-Moist Watercolor Sets

These richly pigmented, semi-moist watercolors provide excellent quality at an economical price. Each set includes a brush and a color mixing guide on the back of the case. For set colors, visit DickBlick.com.

NUMBER	DESCRIPTION	EACH	12/EA
A01770-1008	G Standard Colors, Set of 8	\$5.24	\$4.69
A01770-1012	Standard Colors, Set of 12	5.99	5.46
A01770-1016	Standard Colors, Set of 16	5.75	5.51
A01770-1024	Standard Colors, Set of 24	8.69	7.90
A01770-1010	Pearlescent Colors, Set of 10	5.79	5.21
A01770-1020	Pearlescent Colors, Set of 20	8.94	8.05

H Class Pack of 27 — Each watercolor set in this class pack includes eight colors, one each of Red, Orange, Blue, Black, Green, Purple, Brown, and Yellow, plus a brush. This class pack also includes 50 sheets of 9" x 12" watercolor paper.

NUMBER	EACH
A01770-1027	\$124.60

Class Pack of 36 — This pack contains 36 Standard Color Sets of 8, each with Yellow, Red, Crimson, Burnt Sienna, Green, Turquoise Green, Blue, Black, and a brush, plus a 50-sheet pack of 6" x 9" 88 lb watercolor paper, one large color wheel, and 30 small color wheels.

NUMBER	EACH
A01770-1001	\$128.07

I-K Yarka® Student Watercolor Sets

Made in Russia, Yarka Student semi-moist watercolors feature 8-, 10-, and 12-color palettes of naturally pigmented, liquid-poured, transparent watercolor.

NUMBER	SET	EACH	6/EA
A00336-1029	I 8 Colors	\$6.05	\$5.51
A00336-1009	J 10 Colors	7.81	6.99
A00336-1019	K 12 Colors	7.99	7.33

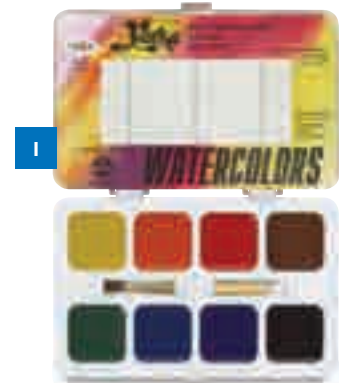

PRANG®

L-O Prang® Semi-Moist Watercolor Sets

Still manufactured according to the true, semi-moist formula that's made Prang famous, these paints are brilliantly transparent. Watercolor sets are packaged in durable plastic cases and include a brush with an easy-to-grip wood handle. The extra-deep pans are easily replaced by refills.

8-Color Set — Includes Red, Orange, Yellow, Green, Blue, Violet, Brown, and Black.

NUMBER	DESCRIPTION	EACH	12/EA
A00305-1019	L Oval	\$4.99	\$4.49
A00305-1029	M Square	5.85	5.26

16-Color Set — Contains all eight colors listed above, plus Red-Orange, Yellow-Orange, Yellow-Green, Blue-Green, Turquoise-Blue, Blue-Violet, Red-Violet, and White.

NUMBER	DESCRIPTION	EACH	12/EA
A00305-1009	N Oval	\$10.78	\$9.19
A00305-1008	O Square	10.59	9.48

P Prang® Semi-Moist Watercolor Class Pack

Perfect for a classroom full of budding artists. Includes 24, 8-color oval sets and 12 refill trays.

NUMBER	EACH	6/EA
A00305-1039	\$139.22	\$125.29

Q-R Prang® Semi-Moist Refills

Individual pans snap into empty paint wells. Colors can be assorted for quantity pricing.

Oval Half Pan Refills — Package of 12, one color.

NUMBER	COLOR	NUMBER	COLOR
A00306-2009	Black	A00306-3389	Red-Orange
A00306-5009	Blue	A00306-6729	Red-Violet
A00306-5609	Blue-Green	A00306-5119	Turquoise
A00306-5399	Blue-Violet	A00306-6509	Violet
A00306-8009	Brown	A00306-1019	White
A00306-7009	Green	A00306-4009	Yellow
A00306-3049	Magenta	A00306-7349	Yellow-Green
A00306-4509	Orange	A00306-4839	Yellow-Orange
A00306-3009	Red		

EACH	12/EA
\$8.31	\$7.29

Square Half Pan Refills — Package of 12, one color.

NUMBER	COLOR	NUMBER	COLOR
A00306-2008	Black	A00306-3008	Red
A00306-5008	Blue	A00306-6728	Red-Violet
A00306-5398	Blue-Violet	A00306-5118	Turquoise
A00306-8008	Brown	A00306-6508	Violet
A00306-7008	Green	A00306-1008	White
A00306-3048	Magenta	A00306-4008	Yellow
A00306-4508	Orange		

EACH	12/EA
\$6.97	\$6.26

Q Oval 8-Color Refill Tray — Eight oval half pans on a plastic strip, fits plastic box: Red, Orange, Yellow, Green, Blue, Violet, Brown, and Black. Package of 12 trays.

NUMBER	EACH	12/EA
A00306-0059	\$36.18	\$27.89

R Square 8-Color Refill Tray — Eight square half pans on a plastic strip, fits plastic box: Red, Orange, Yellow, Green, Blue, Violet, Brown, and Black. Package of 12 trays.

NUMBER	EACH	12/EA
A00306-1009	\$41.31	\$36.75





Talens™ Opaque Watercolor Pan Sets

Made in Holland, these paints offer excellent quality at an affordable price for the student or beginning painter. Opaque watercolors offer solid coverage for gouache-like effects. Each removable pan is 1-3/16" Dia and snaps into place in the sturdy metal case. Sets include a 0.17 oz (5 ml) tube of Opaque White.

NUMBER	SET	EACH	3/EA
A00308-1009	12 Colors	\$22.60	\$20.65
A00308-1029	24 Colors	40.25	36.22



Pelikan™ Opaque Watercolor Sets

These watercolors from Germany are made using high-quality pigments of the finest grain size, in unique, hollowed paint tablets for quicker solubility. The brilliant, dense colors deliver good lightfastness. Sets also include a tube of Chinese White.

NUMBER	SET	EACH	5/EA
A00367-1129	12 Colors	\$16.53	\$14.96
A00367-1249	24 Colors	30.86	27.78



Cretacolor™ Aqua Brique Set

The only watercolor block you can draw with! Add a few drops of water, and you've got liquid watercolors. Highest-quality pigments assure smooth color laydown for classic watercolor work, sketching, drawing, sgraffito, blending, and monoprint. The colors can be thinned for use in airbrushes. Includes a sponge.

NUMBER	SET	EACH
A22059-1109		\$27.41



Finetec™ Artist Mica Watercolor Sets

These fine watercolors are made with mica, a natural mineral that shimmers and shines. They're ideal for adding special effects and highlights to watercolor paintings and for calligraphy. For set colors, visit DickBlick.com.

NUMBER	COLOR	EACH	12/EA
A01668-3716	Amethyst	\$9.15	\$8.23
A01668-3706	Amethyst (Iridescent)	9.15	8.23
A01668-9026	Arabic Gold	9.15	8.23
A01668-5006	Blue Silver	9.15	8.23
A01668-9606	Bronze	9.15	8.23
A01668-7006	Caribbean Green	9.15	8.23
A01668-1196	Champagne	9.15	8.23
A01668-9506	Copper	9.15	8.23
A01668-9006	Crystal Gold	9.15	8.23
A01668-2146	Deep Black	9.15	8.23
A01668-1017	Emerald	9.15	8.23
A01668-1014	Fuchsia	9.15	8.23
A01668-9016	Gold (Iridescent)	9.15	8.23
A01668-9526	Golden Copper (Iridescent)	9.15	8.23
A01668-1011	Golden Rose	9.15	8.23
A01668-1012	Hazelnut	9.15	8.23
A01668-1020	High Chroma Blue	9.15	8.23
A01668-7226	Jade Green (Iridescent)	9.15	8.23
A01668-6016	Light Purple (Iridescent)	9.15	8.23
A01668-1018	Mint	9.15	8.23
A01668-1016	Mystic Color	9.15	8.23
A01668-9036	Olympic Gold	9.15	8.23
A01668-4516	Orange Copper	9.15	8.23
A01668-9256	Pearl Gold	9.15	8.23
A01668-9376	Pearl Silver	9.15	8.23
A01668-5080	Pearlescent Dark Teal	9.15	8.23
A01668-1021	Platinum	9.15	8.23
A01668-6006	Purple	9.15	8.23
A01668-3016	Red	9.15	8.23
A01668-9119	Royal Gold	9.15	8.23
A01668-1013	Ruby	9.15	8.23
A01668-5296	Sapphire Blue	9.15	8.23
A01668-5096	Sapphire Blue (Iridescent)	9.15	8.23
A01668-9336	Silver	9.15	8.23
A01668-1010	Tangelo	9.15	8.23
A01668-1015	Vintage Lilac	9.15	8.23

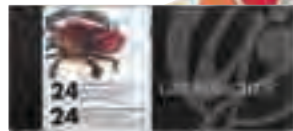

Grumbacher™ Opaque Pan Watercolor Sets

Enjoy the velvety coverage of these opaque watercolors from Grumbacher. The colors are poured into large, circular cakes that snap in and out of their trays for cleaning and rearranging. Each set includes a pointed round Red Sable watercolor brush and a 0.17 oz (5 ml) tube of Chinese White.

NUMBER	SET	EACH	12/EA
A00303-1009	12 Colors	\$26.20	\$23.57
A00303-1029	24 Colors	36.93	33.45



Lyra™ Opaque Watercolor Sets

Artists' quality at a value price! These sets of 12 or 24 opaque watercolors are bold and brilliant with excellent laydown capabilities — great for beginning and experienced artists alike. Each set also includes a tube of white paint and a brush.

NUMBER	SET	EACH	6/EA
A01751-1012	12 Colors	\$11.45	\$10.30
A01751-1024	24 Colors	18.21	15.82



Niji™ Pearlescent Watercolor Sets

These pearlescent paints combine light and color to create stunning effects — either alone or when combined with other waterbased media. Watercolor cakes are contained in portable hinged cases with a lid that doubles as a palette. Great for students and watercolorists as well as for crafts like rubber stamping.

NUMBER	SET	EACH	6/EA
A01727-1016	16 Colors	\$4.95	\$4.48
A01727-1021	21 Colors	7.04	6.33



Niji™ Aquarelle Watercolor Pan Set

These 36 brilliant colors dry to a matte finish. Great for all skill levels.

NUMBER	SET	EACH	6/EA
A00334-1369		\$11.61	\$10.45



Pelikan™ Transparent Watercolor Sets

These watercolors from Germany are made using fine-grain, high-quality pigments. Easily soluble, they deliver brilliant color and good lightfastness. The plastic palette box features brush-wiping edges.

NUMBER	SET	EACH	5/EA
A00367-0129	12 Colors	\$36.07	\$32.69
A00367-0249	24 Colors	52.56	47.60



Yarka™ St. Petersburg Professional Watercolor Sets

Made in a country rich with art history, these watercolors are created using a traditional liquid-poured process that yields what professionals consider to be the highest grade of semi-moist pans. For set colors, visit DickBlick.com.

NUMBER	SET	EACH	6/EA
A00335-0000	Original Set of 24	\$106.52	\$95.88
A00335-0249	Expanded Set of 24	106.52	95.88
A00335-1249	Sequel Set of 24	106.52	95.88
NUMBER	SET	EACH	12/EA
A00335-0369	Ultimate Set of 36	\$127.81	\$115.03

For set colors, visit DickBlick.com.



Sennelier™ La Petite Aquarelle Watercolor Half Pan Sets

A comfortable, wide elastic strap is built into this box, keeping it securely in the palm of your hand while you paint en plein air. Half pan watercolors are bright, delicate, and mix well.

NUMBER	SET	EACH	6/EA
A01669-1129	12 Colors	\$24.30	\$21.82
A01669-1249	24 Colors	44.54	40.09

new!

NEW! Sakura™ Koi Creative Art Colors Watercolor Sets

Perfect for on-the-go watercolor projects! Each pocket-sized set features unique half pan watercolors that mix well. Set of 12 includes one dabbing sponge and a 4 ml small tip water brush. Set of 24 includes two dabbing sponges, a 9 ml barrel medium tip water brush, detachable pallet, and pull-down ring on the base for gripping. For more details, visit DickBlick.com.

NUMBER	DESCRIPTION	EACH	6/EA
A01682-1009	Set of 12	\$19.52	\$17.57
A01682-1019	Set of 24	28.13	25.32



Talens™ Transparent Watercolor Pan Sets

Made in Holland, these transparent watercolors offer excellent quality at an affordable price for the student or beginning painter. Each removable pan is 1-3/16" Dia and snaps into place in the sturdy metal case. Sets also include a 0.17 oz (5 ml) tube of Opaque White.

NUMBER	SET	EACH	3/EA
A00308-1019	12 Colors	\$22.60	\$20.65
A00308-1039	24 Colors	40.25	36.22



Koh-I-Noor™ Watercolor Wheel

24 brilliant pans of watercolor neatly stack in four interlocking trays, topped with a crystal-clear plastic lid. Excellent quality and convenient portability make this a great value. Trays are 3-1/4" Dia. Pans 7/8" Dia.

NUMBER	SET	EACH	6/EA
A00381-1001		\$9.29	\$8.36



Set of 24



Set of 36

Angora Watercolor Pan Sets

Made in Germany, these high-quality, long-lasting watercolors are brilliant and non-toxic. Each removable pan is 7/8" (22 mm) in diameter and snaps into place in its sturdy case.

NUMBER	SET	EACH	6/EA
A00395-0149	14 Colors	\$14.47	\$12.99
A00395-0249	24 Colors	24.41	21.97
A00395-0369	36 Colors	33.57	30.22
A00395-1249	Inclusive Skin Tone 24 Pans	24.76	22.28



Grumbacher™ Transparent Pan Watercolor Sets

Enjoy the clarity of these transparent watercolors from Grumbacher. The colors are poured into large, circular cakes that snap in and out of their trays for cleaning and rearranging. Both sets include a pointed round red sable watercolor brush.

NUMBER	SET	EACH	12/EA
A00303-1019	12 Colors	\$35.20	\$31.66
A00303-1039	24 Colors	51.62	46.45



Daler-Rowney™ Aquafine Watercolor Half Pan Sets

For set colors, visit DickBlick.com. Both sets include a brush.

NUMBER	DESCRIPTION	EACH	3/EA
A01799-1129	Set of 12	\$21.89	\$19.07
A01799-1249	Set of 24	42.39	38.15



Talens Art Creation Watercolor Sets

This transparent paint is made with high-quality pigments and binders for smooth, even washes. Perfect for aspiring, student, and novice artists, it also makes a great gift. Thin it with water to create transparent layers of color. 0.41 oz (12 ml) tubes.

Set of 12 — Chinese White, Yellow, Scarlet, Alizarin Crimson, Cobalt Blue (Ultramarine), Cerulean Blue (Phthalo), Yellowish Green, Deep Green, Yellow Ochre, Burnt Sienna, Burnt Umber, and Payne's Grey.

NUMBER	EACH	6/EA
A01695-1129	\$10.98	\$9.90

Set of 24 — The colors in the Set of 12, plus Lemon Yellow, Raw Sienna, Vermilion, Carmine, Violet, Ultramarine, Prussian Blue, Light Green, Sap Green, Raw Sienna, Raw Umber, and Ivory Black.

NUMBER	EACH	3/EA
A01695-1249	\$21.14	\$18.99



Yarka Student Watercolor Set

Includes 12, 0.25 oz (7.5 ml) tubes of collegiate-quality watercolor: Lemon Yellow, Medium Yellow, Scarlet, Crimson Red, Cerulean Blue, Ultramarine Blue, Light Green, Sap Green, Yellow Ochre, Burnt Sienna, Raw Umber, and Ivory Black.

NUMBER	EACH	12/EA
A00348-1012	\$23.97	\$21.57



Sakura Koi Watercolor Sets

These watercolor sets feature specially selected, high-quality pigments that offer subtle gradations of color, yet provide vibrant color options. For set colors, visit DickBlick.com.

NUMBER	EACH	6/EA
A00378-0189	\$52.09	\$46.89



Van Gogh Watercolor Sets

Easy to mix and wash, these watercolors are intense, lively, and very transparent. Every brilliant color in the line features the highest degree of lightfastness. 0.34 oz (10 ml) tubes.

Set of 12 Tubes — Permanent Red Light, Madder Lake Deep, Permanent Lemon Yellow, Azo Yellow Medium, Yellow Ochre, Cobalt Blue, Ultramarine Deep, Permanent Green, Viridian, Payne's Gray, Burnt Sienna, and Chinese White, plus brush and sponge.

NUMBER	EACH	6/EA
A00327-0019	\$48.60	\$43.74

Set of 10 Tubes — Azo Yellow Medium, Burnt Sienna, Cerulean Blue (Phthalo), Chinese White, Madder Lake Deep, Payne's Gray, Permanent Lemon Yellow, Permanent Red Light, Ultramarine Deep, and Viridian.

NUMBER	EACH	6/EA
A00327-0109	\$39.04	\$35.18



Sennelier La Petite Aquarelle Watercolor Travel Box Set of 12

A comfortable, wide elastic strap is built into this box, keeping it securely in the palm of your hand while you paint en plein air. Watercolors are bright, delicate, and mix well. Burnt Umber, Cobalt Blue Hue, Deep Green, Green Yellow, Orange, Payne's Grey, Primary Blue, Primary Red, Primary Yellow, Rose Madder Lacquer, Titanium White, and Yellow Ochre in 0.33 oz (10 ml) tubes.

NUMBER	EACH	6/EA
A01669-1219	\$41.16	\$37.04

Sargent Art Watercolor Aquarelle Set

Brilliant, versatile, blendable watercolors are ideal for all works on paper. Waterbased and easy to clean before drying, they are AP-certified non-toxic. Set includes 12 popular colors in 0.4 oz (12 ml) tubes.

NUMBER	EACH	6/EA
A01760-1129	\$7.99	\$7.20

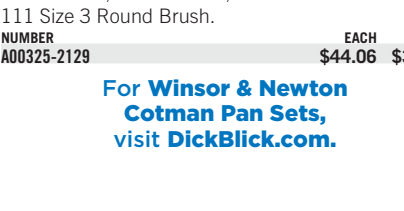
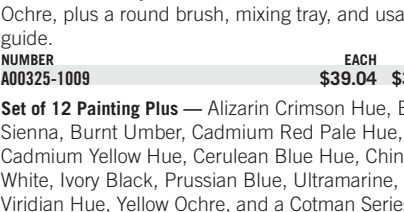
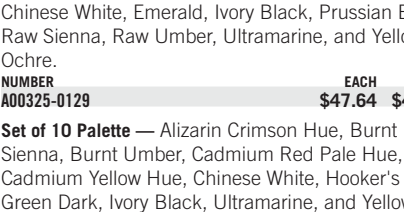
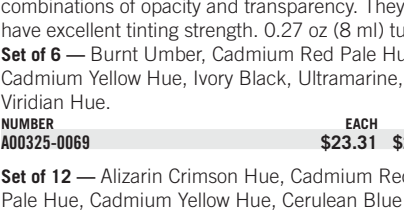

Winsor & Newton Cotman Watercolor Sets

These watercolors represent superb value and are compatible with acrylics and gouache to produce combinations of opacity and transparency. They have excellent tinting strength. 0.27 oz (8 ml) tubes.

Set of 6 — Burnt Umber, Cadmium Red Pale Hue, Cadmium Yellow Hue, Ivory Black, Ultramarine, and Viridian Hue.

NUMBER	EACH	6/EA
A00325-0069	\$23.31	\$20.98

Set of 12 — Alizarin Crimson Hue, Cadmium Red Pale Hue, Cadmium Yellow Hue, Cerulean Blue Hue, Chinese White, Emerald, Ivory Black, Prussian Blue, Raw Sienna, Raw Umber, Ultramarine, and Yellow Ochre.

NUMBER	EACH	6/EA
A00325-0129	\$47.64	\$42.87

Set of 10 Palette — Alizarin Crimson Hue, Burnt Sienna, Burnt Umber, Cadmium Red Pale Hue, Cadmium Yellow Hue, Chinese White, Hooker's Green Dark, Ivory Black, Ultramarine, and Yellow Ochre, plus a round brush, mixing tray, and usage guide.

NUMBER	EACH	6/EA
A00325-1009	\$39.04	\$35.14

Set of 12 Painting Plus — Alizarin Crimson Hue, Burnt Sienna, Burnt Umber, Cadmium Red Pale Hue, Cadmium Yellow Hue, Cerulean Blue Hue, Chinese White, Ivory Black, Prussian Blue, Ultramarine, Viridian Hue, Yellow Ochre, and a Cotman Series 111 Size 3 Round Brush.

NUMBER	EACH	6/EA
A00325-2129	\$44.06	\$39.66

For Winsor & Newton Cotman Pan Sets, visit DickBlick.com.



Van Gogh Watercolor Half Pan Sets

Colors can be assorted for quantity pricing. 0.33 oz (10 ml) Tubes

NUMBER	COLOR	EACH	10/EA
A00327-4921	Azo Yellow Deep	\$4.52	\$4.06
A00327-4931	Azo Yellow Light	4.52	4.06
A00327-4601	Azo Yellow Medium	4.52	4.06
A00327-8041	Burnt Sienna	4.52	4.06
A00327-8051	Burnt Umber	4.52	4.06
A00327-5161	Cerulean Blue	4.52	4.06
A00327-1051	Chinese White	4.52	4.06
A00327-5181	Cobalt Blue Ultramarine	4.52	4.06
A00327-4941	Gamboge	4.52	4.06
A00327-7911	Hooker Green Deep	4.52	4.06
A00327-7721	Hooker Green Light	4.52	4.06
A00327-5201	Indigo	4.52	4.06
A00327-2251	Ivory Black	4.52	4.06
A00327-3711	Light Oxide Red	4.52	4.06
A00327-3741	Madder Lake Deep	4.52	4.06
A00327-3721	Madder Lake Light	4.52	4.06
A00327-4761	Naples Yellow Red	4.52	4.06
A00327-7071	Olive Green	4.52	4.06
A00327-2561	Payne's Gray	4.52	4.06
A00327-5911	Perm Blue Violet	4.52	4.06
A00327-4391	Perm Lemon Yellow	4.52	4.06
A00327-3831	Perm Red Deep	4.52	4.06
A00327-3821	Perm Red Light	4.52	4.06
A00327-3731	Perm Red Violet	4.52	4.06
A00327-7921	Perm Yellowish Green	4.52	4.06
A00327-7551	Perm Green	4.52	4.06
A00327-4911	Perma Orange	4.52	4.06
A00327-5141	Phthalo Blue	4.52	4.06
A00327-7061	Phthalo Green	4.52	4.06
A00327-5221	Prussian Blue	4.52	4.06
A00327-3841	Quinacridone Rose	4.52	4.06
A00327-8061	Raw Sienna	4.52	4.06
A00327-8071	Raw Umber	4.52	4.06
A00327-7091	Sap Green	4.52	4.06
A00327-8081	Sepia	4.52	4.06
A00327-5251	Ultramarine Deep	4.52	4.06
A00327-8311	Vandyke Brown	4.52	4.06
A00327-3281	Vermilion	4.52	4.06
A00327-7101	Viridian	4.52	4.06
A00327-4041	Yellow Ochre	4.52	4.06

For 32 new colors of Van Gogh Watercolors See Insert between 24 & 25



Van Gogh Watercolor Half Pan Sets

Twelve half pans and a pointed round Size 6 synthetic pocket brush. For colors, visit DickBlick.com.

Pocket Box Set of 12 Pans — Includes Yellow Ochre, Burnt Sienna, Payne's Gray, Viridian, Sap Green, Ultramarine Deep, Cerulean Blue, Permanent Red Light, Madder Lake Deep, Chinese White, Permanent Lemon Yellow, and Azo Yellow Medium, plus a Size 6 Round synthetic pocket brush.

NUMBER	EACH	6/EA
A00327-1009	\$35.58	\$32.06

NUMBER	EACH	6/EA
A00327-9018	\$55.24	\$49.71



Winsor & Newton Cotman Watercolor Tube and Half Pan Sets

Colors can be assorted for quantity pricing. 0.27 oz (8 ml) Tubes

NUMBER	COLOR	EACH	6/EA
A00325-3061	Alizarin Crimson Hue	\$3.83	\$3.44
A00325-8041	Burnt Sienna	3.83	3.44
A00325-8051	Burnt Umber	3.83	3.44
A00325-4541	Cadmium Orange Hue	3.83	3.44
A00325-3321	Cadmium Red Dp Hue	3.83	3.44
A00325-3541	Cadmium Red Hue	3.83	3.44
A00325-3711	Cadmium Red Pale Hue	3.83	3.44
A00325-4351	Cadmium Yellow Hue	3.83	3.44
A00325-4251	Cadmium Ylw Pale Hue	3.83	3.44
A00325-5171	Cerulean Blue Hue	3.83	3.44
A00325-1051	Chinese White	3.83	3.44
A00325-5191	Cobalt Blue Hue	3.83	3.44
A00325-6911	Dioxazine Violet	3.83	3.44
A00325-7051	Emerald	3.83	3.44
A00325-4501	Gamboge Hue	3.83	3.44
A00325-7911	Hooker's Green Dark	3.83	3.44
A00325-7721	Hooker's Green Light	3.83	3.44
A00325-3251	Indian Red	3.83	3.44
A00325-5201	Indigo	3.83	3.44
A00325-2251	Ivory Black	3.83	3.44
A00325-2021	Lamp Black	3.83	3.44
A00325-4911	Lemon Ylw Hue #1	3.83	3.44
A00325-3011	Light Red	3.83	3.44
A00325-6061	Mauve	3.83	3.44
A00325-2561	Payne's Gray	3.83	3.44
A00325-3261	Permanent Rose	3.83	3.44
A00325-5141	Phthalo Blue	3.83	3.44
A00325-7061	Phthalo Green	3.83	3.44
A00325-5221	Prussian Blue	3.83	3.44
A00325-6101	Purple Lake	3.83	3.44
A00325-8061	Raw Sienna	3.83	3.44
A00325-8071	Raw Umber	3.83	3.44
A00325-3721	Rose Madder Alizarin	3.83	3.44
A00325-7091	Sap Green	3.83	3.44
A00325-8081	Sepia	3.83	3.44
A00325-5111	Turquoise	3.83	3.44
A00325-5231	Ultramarine	3.83	3.44
A00325-8311	Vandyke Brown	3.83	3.44
A00325-7191	Viridian Hue	3.83	3.44
A00325-4041	Yellow Ochre	3.83	3.44



Winsor & Newton Cotman Watercolor Tube and Half Pan Sets

Compact Set — Includes 14 half pans of Cotman Watercolor, Series 111 Cotman Watercolor brush, mixing surfaces, sliding palette, and mediums dish.

NUMBER	EACH	6/EA
A00325-1029	\$30.53	\$27.48

Painting Plus Set of 24 — Includes 24 half pan Cotman Watercolors housed in a compact white plastic travel box that doubles as a portable palette, plus a Cotman Series 111 Size 3 brush.

NUMBER	EACH	6/EA
A00337-1089	\$58.68	\$52.81

Sketcher's Pocket Box Set of 12 — Includes 12 half pan Cotman Watercolors in a sturdy plastic box, plus a pocket Scepter brush.

NUMBER	EACH	6/EA
A00337-1059	\$23.46	\$21.11

For Cotman Watercolor Pans, visit DickBlick.com.



Grumbacher Academy Watercolors

Colors can be assorted for quantity pricing. 0.25 oz (7.5 ml) Tubes

NUMBER	COLOR	EACH	12/EA
A00330-3061	Alizarin Crimson	\$4.42	\$3.99
A00330-4911	Alizarin Orange		
A00330-8041	Burnt Sienna		
A00330-8051	Burnt Umber		
A00330-4541	Cadmium Orange Hue		
A00330-3321	Cadmium Red Dp Hue		
A00330-3181	Cadmium Red Lt Hue		
A00330-3231	Cadmium Red Med Hue		
A00330-4281	Cadmium Ylw Dp Hue		
A00330-4191	Cad Yellow Med Hue		
A00330-4251	Cad Yellow Pale Hue		
A00330-3711	Carmine Red Hue		
A00330-5171	Cerulean Blue Hue		
A00330-2611	Charcoal Gray		
A00330-1051	Chinese White		
A00330-7111	Chromium Oxide Green		
A00330-5191	Cobalt Blue Hue		
A00330-2621	Davy's Gray		
A00330-7051	Emerald Green		
A00330-4501	Gamboge Yellow Hue		
A00330-3710	Geranium Lake		
A00330-4081	Golden Yellow		
A00330-7911	Grn Erth Hue (Tra Vrte)		
A00330-3721	Grumbacher Red (Nphtl)		
A00330-7921	Hooker's Grn Dp Hue		
A00330-7931	Hooker's Green Light Hue		
A00330-3731	Indian Red (Venetian)		
A00330-4161	Indian Yellow Hue		
A00330-5201	Indigo		
A00330-2251	Ivory Black		
A00330-2021	Lamp Black		
A00330-4921	Lemon Yellow (Hansa)		
A00330-3011	Light Red		
A00330-6061	Mauve		
A00330-7901	Magnesium Green		
A00330-4241	Naples Yellow Hue		
A00330-7941	Olive Green Hue		
A00330-2561	Payne's Gray		
A00330-7081	Permanent Green Light		
A00330-8911	Perylene Maroon		
A00330-5221	Prussian Blue		
A00330-8061	Raw Sienna		
A00330-8071	Raw Umber		
A00330-3501	Rose Madder Hue		
A00330-7091	Sap Green		
A00330-3411	Scarlet Lake		
A00330-8081	Sepia		
A00330-5141	Thalo® Blue		
A00330-3741	Thalo® Crimson		
A00330-7181	Thalo® Grn (Blue Shade)		
A00330-3401	Thalo® Red		
A00330-7571	Thalo® Ylw (Grn Shade)		
A00330-6551	Thio™ Violet		
A00330-5111	Turquoise		
A00330-5231	Ultramarine Blue		
A00330-8311	Van Dyke Brown Hue		
A00330-3421	Vermilion Hue		
A00330-6911	Violet (Thalo® Purple)		
A00330-7101	Viridian		
A00330-4931	Yellow Ochre Hue		



Grumbacher 10-Tube Set

Includes 10, 0.25 oz (7.5 ml) tubes, camel hair brush, mixing tray, and watercolor guide. Colors: Alizarin Crimson, Burnt Sienna, Cadmium Yellow Pale Hue, Chinese White, Cobalt Blue Hue, Grumbacher Red, Ivory Black, Thalo Green, Ultramarine

WINSOR & NEWTON™



Winsor & Newton™ Professional Watercolors

Since 1832, Winsor & Newton Professional Watercolors have been renowned for unmatched purity, quality, and reliability.

COLOR	0.17 OZ (5 ML)	EACH	0.47 OZ (14 ML)	EACH
Alizarin Crimson	A00319-3061	\$8.89	A00319-3062	\$17.90
Antwerp Blue	A00319-5911	8.89	A00319-5912	17.90
Aqua Green	A00319-7110	11.38	A00319-7092	21.56
Aureolin	A00319-4271	13.40	A00319-4272	28.05
Brown Madder	A00319-8211	8.89	A00319-8212	17.90
Brown Ochre	A00319-8201	8.89	A00319-8202	17.90
Burnt Sienna	A00319-8041	8.89	A00319-8042	17.90
Burnt Umber	A00319-8051	8.89	A00319-8052	17.90
Cad-Free Lemon	A00319-4171	13.40	A00319-4172	28.05
Cad-Free Orange	A00319-3541	13.40	A00319-4512	28.05
Cad-Free Red	A00319-3321	13.40	A00319-3192	28.05
Cad-Free Red Deep	A00319-3191	13.40	A00319-3212	28.05
Cad-Free Scarlet	A00319-3551	13.40	A00319-3402	28.05
Cad-Free Yellow	A00319-4191	13.40	A00319-4192	28.05
Cad-Free Yellow Dp	A00319-4111	13.40	A00319-4112	28.05
Cad-Free Yellow Pale	A00319-4291	13.40	A00319-4292	28.05
Cadmium Lemon	A00319-4181	13.40	A00319-4182	28.05
Cadmium Orange	A00319-4531	13.40	A00319-4532	28.05
Cadmium Red	A00319-3331	13.40	A00319-3332	28.05
Cadmium Red Deep	A00319-3201	13.40	A00319-3202	28.05
Cadmium Scarlet	A00319-3561	13.40	A00319-3562	28.05
Cadmium Yellow	A00319-4201	13.40	A00319-4202	28.05
Cadmium Yellow Deep	A00319-4121	13.40	A00319-4122	28.05
Cadmium Yellow Pale	A00319-4301	13.40	A00319-4302	28.05
Caput Mortum Violet	A00319-6651	10.05	A00319-6652	19.90
Cerulean Blue	A00319-5161	11.38	A00319-5162	21.56
Chinese White	A00319-1051	8.89	A00319-1052	17.90
Cobalt Blue	A00319-5181	13.40	A00319-5182	28.05
Cobalt Blue Deep	A00319-5381	13.40	A00319-5382	28.05
Cobalt Green	A00319-7161	13.40	A00319-7162	28.05
Cobalt Green Dp	A00319-7170	11.38	A00319-7172	21.56
Cobalt Turquoise	A00319-5371	13.40	A00319-5372	28.05
Cobalt Turquoise Lt	A00319-5921	13.40	A00319-5922	28.05
Davy's Gray	A00319-2631	8.89	A00319-2632	17.90
French Ultramarine	A00319-5271	10.05	A00319-5272	19.90
Gold Ochre	A00319-9031	10.05	A00319-9032	19.90
Green Gold	A00319-9061	10.05	A00319-9062	19.90
Hooker's Green	A00319-7121	8.89	A00319-7122	17.90
Indanthrene Blue	A00319-5341	11.38	A00319-5342	21.56
Indian Red	A00319-3251	8.89	A00319-3252	17.90
Indian Yellow	A00319-4161	8.89	A00319-4162	17.90
Indigo	A00319-5201	8.89	A00319-5202	17.90

COLOR	0.17 OZ (5 ML)	EACH	0.47 OZ (14 ML)	EACH
Ivory Black	A00319-2251	\$8.89	A00319-2252	\$17.90
Lamp Black	A00319-2021	8.89	A00319-2022	17.90
Lemon Yellow Deep	A00319-4101	10.05	A00319-4102	19.90
Manganese Blue Hue	A00319-5331	10.05	A00319-5332	19.90
Mars Black	A00319-2041	8.89	A00319-2042	17.90
Naples Yellow	A00319-4141	8.89	A00319-4142	17.90
Naples Yellow Deep	A00319-4521	8.89	A00319-4522	17.90
Neutral Tint	A00319-2551	8.89	A00319-2552	17.90
New Gamboge	A00319-4811	8.89	A00319-4812	17.90
Olive Green	A00319-7071	8.89	A00319-7072	17.90
Opera Rose	A00319-3761	10.05	A00319-3762	19.90
Payne's Gray	A00319-2561	8.89	A00319-2562	17.90
Permanent Aliz Crimson	A00319-3391	11.38	A00319-3392	21.56
Permanent Magenta	A00319-3491	11.38	A00319-3492	21.56
Permanent Mauve	A00319-3871	11.38	A00319-3872	21.56
Permanent Rose	A00319-3261	11.38	A00319-3262	21.56
Permanent Sap Green	A00319-7391	8.89	A00319-7392	17.90
Perylene Green	A00319-7851	10.05	A00319-7852	19.90
Perylene Maroon	A00319-8911	11.38	A00319-8912	21.56
Perylene Violet	A00319-6701	10.05	A00319-6702	19.90
Phthalo Turquoise	A00319-5421	10.05	A00319-5422	19.90
Potters Pink	A00319-3771	10.05	A00319-3772	19.90
Prussian Blue	A00319-5221	8.89	A00319-5222	17.90
Quinacridone Gold	A00319-9091	11.38	A00319-9092	21.56
Quinacridone Magenta	A00319-3621	11.38	A00319-3622	21.56
Quinacridone Red	A00319-3271	11.38	A00319-3272	21.56
Quinacridone Violet	A00319-6510	11.38	A00319-6512	21.56
Raw Sienna	A00319-8061	8.89	A00319-8062	17.90
Raw Umber	A00319-8071	8.89	A00319-8072	17.90
Rose Madder Genuine I	A00319-3731	13.40	A00319-3712	28.05
Scarlet Lake	A00319-3411	10.05	A00319-3412	19.90
Sepia	A00319-8081	8.89	A00319-8082	17.90
Smalt	A00319-5901	11.38	A00319-5902	21.56
Terre Verte	A00319-7131	8.89	A00319-7132	17.90
Titanium White	A00319-1011	8.89	A00319-1012	17.90
Transparent Orange	A00319-8011	11.38	A00319-4542	21.56
Transparent Yellow	A00319-4551	8.89	A00319-4552	17.90
Ultramarine Blue GS	A00319-5231	10.05	A00319-5232	19.90
Ultramarine Violet	A00319-6731	10.05	A00319-6732	19.90
Vandyke Brown	A00319-8311	8.89	A00319-8312	17.90
Viridian	A00319-7101	11.38	A00319-7102	21.56
Winsor Blue GS	A00319-5481	8.89	A00319-5482	17.90
Winsor Blue RS	A00319-5631	8.89	A00319-5632	17.90
Winsor Green BS	A00319-7891	8.89	A00319-7892	17.90
Winsor Green YS	A00319-7591	8.89	A00319-7592	17.90
Winsor Lemon	A00319-4901	8.89	A00319-4902	17.90
Winsor Orange	A00319-4821	8.89	A00319-4822	17.90
Winsor Orange RS	A00319-4801	8.89	A00319-4802	17.90
Winsor Red	A00319-3741	8.89	A00319-3742	17.90
Winsor Red Deep	A00319-4881	8.89	A00319-3752	17.90
Winsor Violet	A00319-6741	8.89	A00319-6742	17.90
Winsor Yellow	A00319-4001	8.89	A00319-4002	17.90
Winsor Yellow Deep	A00319-4891	8.89	A00319-4892	17.90
Yellow Ochre	A00319-4041	8.89	A00319-4042	17.90
Yellow Ochre Light	A00319-4841	8.89	A00319-4842	17.90

For Winsor & Newton Watercolor Pans and 1.25 oz (37 ml) tubes, visit DickBlick.com.



GRUMBACHER

Grumbacher Finest Artists' Watercolors are professional-quality colors formulated with premium pigments. Colors can be assorted for quantity pricing.

0.47 oz (14 ml) Tubes				0.47 oz (14 ml) Tubes				0.47 oz (14 ml) Tubes			
NUMBER	COLOR	EACH	6/EA	NUMBER	COLOR	EACH	6/EA	NUMBER	COLOR	EACH	6/EA
A01724-3060	Alizarin Crimson	\$13.54	\$12.19	A01724-6520	Cobalt Violet	\$21.99	\$19.81	A01724-3620	Quinacridone Magenta	\$16.25	\$14.63
A01724-3190	Alizarin Rose	16.25	14.63	A01724-2620	Davy's Gray	13.54	12.19	A01724-3270	Quinacridone Red	16.25	14.63
A01724-4270	Aureolin Yellow	13.54	12.19	A01724-5210	Delft Blue	13.54	12.19	A01724-3790	Quinacridone Rose	17.20	15.47
A01724-4610	Bismuth Yellow	21.99	19.81	A01724-6020	Dioxazine Purple	17.20	15.47	A01724-8060	Raw Sienna	13.54	12.19
A01724-8210	Brown Madder	17.20	15.47	A01724-5270	French Ultramarine	16.25	14.63	A01724-8070	Raw Umber	13.54	12.19
A01724-3390	Burnt Alizarin	13.54	12.19	A01724-4940	Gamboge	16.25	14.63	A01724-3760	Red Iron Oxide	13.54	12.19
A01724-8040	Burnt Sienna	13.54	12.19	A01724-7910	Hooker's Green Deep	13.54	12.19	A01724-7090	Sap Green	16.25	14.63
A01724-8050	Burnt Umber	13.54	12.19	A01724-7720	Hooker's Green Light	13.54	12.19	A01724-8080	Sepia	13.54	12.19
A01724-4530	Cadmium Orange	21.99	19.81	A01724-3250	Indian Red	13.54	12.19	A01724-7130	Terre Verte	16.25	14.63
A01724-3200	Cadmium Red Deep	17.20	15.47	A01724-4160	Indian Yellow	16.25	14.63	A01724-5170	Thalo Blue	13.54	12.19
A01724-3090	Cadmium Red Light	21.99	19.81	A01724-5200	Indigo	13.54	12.19	A01724-7800	Thalo Green	13.54	12.19
A01724-3100	Cadmium Red Med	21.99	19.81	A01724-2250	Ivory Black	13.54	12.19	A01724-6800	Thalo Purple	16.25	14.63
A01724-4120	Cadmium Yellow Deep	21.99	19.81	A01724-2020	Lamp Black	13.54	12.19	A01724-4750	Thalo Yellow Green	13.54	12.19
A01724-4100	Cadmium Yellow Light	17.20	15.47	A01724-4060	Lemon Yellow	16.25	14.63	A01724-1020	Titanium White	13.54	12.19
A01724-4180	Cadmium Yellow Lemon	17.20	15.47	A01724-3040	Magenta	13.54	12.19	A01724-4960	Transparent Orange	21.99	19.81
A01724-4110	Cadmium Yellow Medium	17.20	15.47	A01724-5330	Manganese Blue Hue	13.54	12.19	A01724-3710	True Red	17.20	15.47
A01724-5160	Cerulean Blue	21.99	19.81	A01724-4140	Naples Yellow	13.54	12.19	A01724-5230	Ultramarine Blue	16.25	14.63
A01724-1050	Chinese White	13.54	12.19	A01724-2560	Paynes Gray	13.54	12.19	A01724-8310	Van Dyck Brown	13.54	12.19
A01724-7650	Chrom Oxide Green	13.54	12.19	A01724-3380	Permanent Alizarin	13.54	12.19	A01724-3290	Vermilion Deep	13.54	12.19
A01724-5180	Cobalt Blue	21.99	19.81	A01724-7550	Permanent Green	13.54	12.19	A01724-7480	Viridian	17.20	15.47
A01724-5370	Cobalt Turquoise	17.20	15.47	A01724-5220	Prussian Blue	13.54	12.19	A01724-4040	Yellow Ochre	13.54	12.19

HEALTH & SAFETY ICONS: ●=CL / ■=Prop 65 / ▼=CL & Prop 65 See page 644 for more information.

Utrecht artists' watercolors

Handcrafted in Brooklyn, New York, Utrecht Artists' Watercolors offer clear, intense washes that flood the paper with permanent brilliance. Every one of the 59 colors is made with the finest pigments dispersed in pure gum arabic for excellent clarity, outstanding lightfastness, and luminous transparency. Colors can be assorted for quantity pricing.

14 ml (0.47 oz) Tubes			
NUMBER	COLOR	EACH	6/EA
A01766-3062	Alizarin Crimson	\$10.52	\$9.53
A01766-8622	Buff White	10.52	9.53
A01766-8042	Burnt Sienna	10.52	9.53
A01766-8052	Burnt Umber	10.52	9.53
A01766-4052	Burnt Yellow	10.52	9.53
A01766-4902	Cadmium Orange Pure	17.54	15.41
A01766-3322	Cadmium Red Dp Pure	17.54	15.41
A01766-3092	Cadmium Red Lt Pure	17.54	15.41
A01766-3112	Cadmium Red Med Pure	17.54	15.41
A01766-4282	Cadmium Ylw Dp Pure	17.54	15.41
A01766-4072	Cadmium Ylw Lt Pure	17.54	15.41
A01766-4092	Cadmium Ylw Med Pure	17.54	15.41
A01766-5182	Cerulean Blue Chromium	13.05	11.75
A01766-5162	Cerulean Blue	13.05	11.75
A01766-7112	Chromium Green	10.52	9.53
A01766-5192	Cobalt Blue	17.54	15.41
A01766-5302	Cobalt Teal Pure	17.54	15.41
A01766-2502	Davey's Gray	10.52	9.53
A01766-6022	Dioxazine Purple	11.49	10.93
A01766-4502	English Yellow	13.05	11.75
A01766-5272	French Ultramarine Blue	11.49	10.93
A01766-9012	Golden Earth	13.05	11.75
A01766-4972	Hansa Yellow Deep	11.49	10.93
A01766-7122	Hookers Green	10.52	9.53
A01766-3252	Indian Red	10.52	9.53
A01766-4162	Indian Yellow	10.52	9.53
A01766-5202	Indigo Blue	10.52	9.53
A01766-3072	Intense Pink	17.54	15.41

BLICK® artists' watercolors

Our professional watercolors are made with rich, premium pigments sourced from around the world. They are uniformly combined in balanced mediums to ensure fluid, controlled washes time after time. Of the 63 colors in the line, 40 are made from a single pigment. We also offer real cadmiums and cobalts, not hues. Colors can be assorted for quantity pricing.

0.47 oz (14 ml) Tubes			
NUMBER	COLOR	EACH	6/EA
A01728-3060	Alizarin Crimson	\$10.38	\$9.36
A01728-3710	Alizarin Rose	11.89	10.68
A01728-4270	Aureolin Ylw	12.63	11.37
A01728-4610	Bismuth Yellow	16.30	14.67
A01728-8210	Brown Madder	12.63	11.37
A01728-8040	Burnt Sienna	10.38	9.36
A01728-8050	Burnt Umber	10.38	9.36
A01728-4180	Cadmium Lemon	12.63	11.37
A01728-4530	Cadmium Orange	16.30	14.67
A01728-3200	Cadmium Red Deep	12.63	11.37
A01728-3090	Cadmium Red Light	16.30	14.67
A0172			

Sargent Art® Watercolor Magic®

Bold, brilliant, and made in the USA, this washable liquid watercolor is great for almost any watercolor painting or paper craft project, including rubber stamping. Non-toxic. 8 oz (237 ml) bottles. **Colors can be assorted for quantity pricing.**

COLOR	NUMBER	EACH	12/EA
Antique Gold	A01759-9135		
Black	A01759-2035		
Blue	A01759-5025		
Blue-Green	A01759-5105		
Blue-Violet	A01759-5395		
Brown	A01759-8005		
Copper	A01759-9505		
Coral	A01759-3245		
Fuchsia	A01759-3755		
Gold	A01759-9015		
Green	A01759-7015		
Magenta	A01759-3035		
Orange	A01759-4525		
Pearl	A01759-1095		
Pink	A01759-3065		
Pirate Gold	A01759-9025		
Red	A01759-3025		
Red-Violet	A01759-3765		
Silver	A01759-9335		
Turquoise	A01759-5115		
Violet	A01759-6515		
Yellow	A01759-4025		
Yellow-Green	A01759-4755		
Yellow-Orange	A01759-4255		

Glitter Colors — 8 oz (237 ml) Bottles

COLOR	NUMBER	EACH	12/EA
Black Glitter	A01759-2025	\$5.94	\$5.48
Blue Glitter	A01759-5015		
Green Glitter	A01759-7035		
Magenta Glitter	A01759-3045		
Orange Glitter	A01759-4515		
Red Glitter	A01759-3015		
Violet Glitter	A01759-6065		
Yellow Glitter	A01759-4015		



Sargent Art® Watercolor Magic® Sets

Standard Set of 6 — Blue, Green, Orange, Red, Violet, and Yellow.

NUMBER	SIZE	EACH	6/EA
A01759-1659	8 oz (237 ml)	\$34.45	\$30.99

Standard Set of 6 — Black, Blue, Green, Red, Violet, and Yellow.

NUMBER	SIZE	EACH	6/EA
A01759-1069	1 oz (30 ml)	\$12.34	\$11.10

Fluorescent Set of 6 — Blue, Chartreuse, Green, Pink, Red, and Yellow-Orange.

NUMBER	SIZE	EACH	6/EA
A01759-1685	8 oz (237 ml)	\$34.45	\$30.99

Glitter Set of 6 — Black Glitter, Blue Glitter, Green Glitter, Red Glitter, Violet Glitter, and Yellow Glitter.

NUMBER	SIZE	EACH	6/EA
A01759-2659	8 oz (237 ml)	\$34.45	\$30.99

Metallic Set of 6 — Antique Gold, Copper, Gold, Pearl White, Pirate Gold, and Silver.

NUMBER	SIZE	EACH	6/EA
A01759-1159	8 oz (237 ml)	\$34.45	\$30.99

Standard Set of 10 — Black, Blue, Brown, Green, Magenta, Orange, Red, Turquoise, Violet, and Yellow.

NUMBER	SIZE	EACH	6/EA
A01759-1059	8 oz (237 ml)	\$57.48	\$51.71

Vallejo Liquid Watercolor

Vallejo Liquid Watercolors are acid-free, brilliant, transparent, and have high tinting strength.

They're formulated with a selection of permanent dyes dispersed in water and a solution of gum arabic. They can be extended easily without leaving brushstrokes and mixed together to create unique colors. **Colors can be assorted for quantity pricing.**

COLOR	NUMBER	EACH	6/EA
Black	A01786-2020		
Blue Green	A01786-7760		
Blue Violet	A01786-5390		
Cerulean Blue	A01786-5160		
Chartreuse	A01786-4310		
Coral Red	A01786-3240		
Crimson	A01786-3160		
Dark Grey	A01786-2530		
Deep Brown	A01786-8810		
Deep Red	A01786-3710		
Flesh Tone	A01786-1470		
Forrest Green	A01786-7270		
Gold Green	A01786-7910		
Gold Olive	A01786-7920		
Golden Brown	A01786-8400		
Golden Yellow	A01786-4090		
Harvest Yellow	A01786-4180		
Hot Pink	A01786-3290		
Indigo Blue	A01786-5200		
Lemon Yellow	A01786-4060		
Light Grey	A01786-2510		
Light Orange	A01786-4500		
Light Red	A01786-3010		
Medium Grey	A01786-2520		
Navy Blue	A01786-5040		
Olive Green	A01786-7070		
Orange	A01786-4510		
Orange Brown	A01786-8420		
Orange Red	A01786-4910		
Pink	A01786-3060		
Primary Blue	A01786-5920		
Primary Magenta	A01786-3770		
Primary Yellow	A01786-4530		
Purple Blue	A01786-5910		
Red Brown	A01786-3250		
Rose Red	A01786-3170		
Royal Blue	A01786-5050		
Scarlet Red	A01786-3080		
Seal Brown	A01786-8480		
Sepia	A01786-8080		
Slate Blue	A01786-5310		
Spring Green	A01786-7330		
Super White	A01786-1690		
Turquoise	A01786-5110		
Ultramarine	A01786-5230		
Violet	A01786-6510		
Violet Brown	A01786-8410		
Violet Red	A01786-3760		
Yellow Green	A01786-4750		

NUMBER	DESCRIPTION	EACH	6/EA
A01762-1008	Set of 8	\$47.92	\$43.13
A01762-1012	Set of 12	71.89	64.70
A01762-1024	Set of 24	143.79	129.41
A01762-1009	Set of 6 and Spritzer Bottle	39.57	35.61



Brusho® Crystal Colours Sets

Experiment with versatile, intermixable Brusho Crystal Colours. Sets include 0.5 oz (15 g) jars. For set colors, visit DickBlick.com.

NUMBER	DESCRIPTION	EACH	6/EA
A01762-1008	Set of 8	\$47.92	\$43.13
A01762-1012	Set of 12	71.89	64.70
A01762-1024	Set of 24	143.79	129.41
A01762-1009	Set of 6 and Spritzer Bottle	39.57	35.61



Royal Talens™ Ecoline® Liquid Watercolor in Dropper Jars

Bright and brilliant, these highly concentrated dyes offer intense yet transparent color. The handy dropper cap makes for easy measuring and mixing. The fast-drying colors can be rewet and blended, and are great for painting, drawing, illustration, lettering, and more. For best results, use on white or light-colored papers and boards. Made in Holland. **Colors can be assorted for quantity pricing.**

COLOR	NUMBER	EACH	12/EA
Apricot	A01670-4581		
Beige	A01670-8141		
Black	A01670-2021		
Blue Violet	A01670-6601		
Bluish Green	A01670-7831		
Bronze Green	A01670-7301		
Burnt Sienna	A01670-8711		
Carmine	A01670-3151		
Chartreuse	A01670-4311		
Gold Grey	A01670-2811		
Cold Grey Light	A01670-2821		
Deep Grey	A01670-2541		
Deep Green	A01670-7041		
Deep Ochre	A01670-3731		
Deep Orange	A01670-4521		
Deep Yellow	A01670-4321		
Fir Green	A01670-7191		
Forest Green	A01670-7271		
Fuchsia	A01670-3751		
Gold	A01670-9011		
Gold Ochre	A01670-9031		
Grass Green	A01670-7241		
Green	A01670-7011		
Grey	A01670-2501		
Indigo	A01670-5201		
Lemon Yellow	A01670-4061		
Light Green	A01670-7021		
Light Orange	A01670-4511		
Light Rose	A01670-3501		
Light Yellow	A01670-4011		
Magenta	A01670-3041		
Mahogany	A01670-8441		
Pastel Blue	A01670-5321		
Pastel Green	A01670-7431		
Pastel Red	A01670-3621		
Pastel Rose	A01670-3711		
Pastel Violet	A01670-6531		
Pastel Yellow	A01670-4071		
Pink Beige	A01670-3721		
Prussian Blue	A01670-5221		
Red Violet	A01670-6921		
Reddish Brown	A01670-8221		
Saffron Yellow	A01670-4961		
Sand Yellow	A01670-4911		
Scarlet	A01670-3081		
Sepia	A01670-8081		
Sepia Deep	A01670-8091		
Sky Blue Cyan	A01670-5091		
Sky Blue Light	A01670-5081		
Spring Green	A01670-7331		
Turquoise Blue	A01670-5131		
Turquoise Green	A01670-7911		
Ultramarine Deep	A01670-5341		
Ultramarine Light	A01670-5301		
Ultramarine Violet	A01670-6731		
Vermilion	A01670-3281		
Warm Grey	A01670-2321		
Warm Grey Light	A01670-2331		
White	A01670-1021		
Yellow Ochre	A01670-4041		

Blick® Fluorescent Liquid Watercolors

More exciting choices to spice up your watercolor painting, paper crafts, and other projects. Choose from nine Fluorescent shades for effects that get noticed! Dye-based; may be diluted with up to four parts water. 8 oz (237 ml) clear plastic bottles. **Colors can be assorted for quantity pricing.**

NUMBER	COLOR	EACH	12/EA
A00369-5245	Blue	\$4.93	\$4.40
A00369-7635	Chartreuse		
A00369-7275	Green		
A00369-3485 N	Magenta		
A00369-4565 N	Orange		
A00369-3725	Pink		
A00369-3745	Red		
A00369-6915 N	Violet		
A00369-4915	Yellow Orange		



Blick® Metallic Liquid Watercolors

Six beautiful metallic colors for painting or airbrushing. Also makes a very economical refill for rubber stamps. Ideal for dyeing scrapbooking papers, glues, sand, wood shapes, and fabric — use your imagination! May be diluted with up to four parts water. Washable. 8 oz (237 ml) clear plastic bottles. **Colors can be assorted for quantity pricing.**

COLOR	NUMBER	EACH	12/EA
Antique Gold	A00369-9135		
Copper	A00369-9505		
Gold	A00369-9015		
Pearl	A00369-1095		
Pirate Gold	A00369-9025		
Silver	A00369-9335		

Blick® Liquid Watercolor Sets

Dye-based watercolors formulated with safety in mind. They're non-toxic and contain no latex, dairy, casein, soy, egg, gluten, peanuts, or tree nuts. Made in the USA.

Painting Class Kit — Includes 10 Blick Liquid Watercolors, 12 Blick Scholastic Camel Oval Wash size 3/4", 12 Blick Scholastic Red Sable size 0, 12 Blick Scholastic Red Sable Round size 6, 12 sheets of 15" x 22" Blick Watercolor Paper, and 12 plastic trays. 8 oz (237 ml) clear plastic bottles.

NUMBER	EACH	3/EA
A00390-1009	\$148.38	\$133.50

Set of 10 Colors — Includes Yellow, Orange, Red, Magenta, Violet, Blue, Turquoise, Green, Black, and Brown in 8 oz (237 ml) clear plastic bottles.

NUMBER	EACH	6/EA
A00369-1109	\$42.22	\$37.99

BLICK® liquid watercolors



Blick® Liquid Watercolors

An innovation in watercolor — perfect for classrooms. Use them directly from the bottle for intense single-stroke color. Liquid watercolors can also be diluted with up to four parts water to create a wash effect. Dye-based; some colors may fade. **Colors can be assorted for quantity pricing.**

COLOR	4 OZ (118 ML)	8 OZ (237 ML)
Black	A00369-2024	A00369-2025
Blue	A00369-5004	A00369-5005
Blue Green	—	A00369-5105
Blue Violet	—	A00369-5395
Brown	A00369-8004	A00369-8005
Coral	—	A00369-3245
Fuchsia	—	A00369-3755
Green	A00369-7004	A00369-7005
Magenta	A00369-3044	A00369-3045
Orange	A00369-4504	A00369-4505
Pink	—	A00369-3065
Red	A00369-3004	A00369-3005
Red Violet	—	A00369-3765
Turquoise	A00369-5114	A00369-5115
Violet	A00369-6504	A00369-6505
Yellow	A00369-4004	A00369-4005
Yellow Green	—	A00369-4755
Yellow Orange	—	A00369-4835

NUMBER	EACH	3/EA
A00369-1109	\$3.91	\$3.49





Talens Art Creation Gouache Sets

This gouache is made from high-quality pigment and dextrin binder for smooth, opaque strokes of paint. This water-soluble medium can be thinned with water to create layers without leaving stripes. It dries within several minutes. 0.41 oz (12 ml) tubes.

Set of 12 — White, Lemon Yellow, Light Yellow, Scarlet, Deep Rose, Cobalt Blue (Ultramarine), Light Blue (Cyan), Deep Green, Yellow Ochre, Burnt Sienna, Burnt Umber, and Black.

NUMBER	EACH	6/EA
A00894-1129	\$10.39	\$9.09

Set of 24 — The colors in the Set of 12, plus Medium Yellow, Deep Yellow, Flesh Tint, Vermilion, Carmine, Violet, Ultramarine, Prussian Blue, Azure Blue, Yellowish Green, Light Green, and Sap Green.

NUMBER	EACH	3/EA
A00894-1249	\$19.94	\$17.43



Primary Set



Holbein Artists' Gouache Mixing & Designer Set

Professionally made gouache with naturally opaque pigments. Colors are vibrant and don't muddy when mixed. Brilliant, rich matte finish.

NUMBER	SIZE	SET	EACH	6/EA
A00813-1059	0.5 oz (15 ml)	Primary Mixing Set of 5	44.31	39.88
A00812-2189	0.17 oz (5 ml)	Set of 18	80.59	72.52
A00812-3129	0.17 oz (5 ml)	Set of 12	53.15	47.84
A00812-3189	0.5 oz (15 ml)	Set of 18	162.74	146.49
A00812-3249	0.5 oz (15 ml)	Set of 24	232.91	209.63
A00812-4129	0.5 oz (15 ml)	Set of 12	103.07	92.76



Set of 12

Caran d'Ache Gouache Sets

8-Color Set — Includes 0.34 oz (10 ml) tubes of White, Black, Yellow, Vermilion, Burnt Sienna, Carmine, Ultramarine, and Emerald Green, plus a #5 round camel hair brush.

NUMBER	EACH	6/EA
A00822-0089	\$44.58	\$40.12

12-Color Set — Includes 0.34 oz (10 ml) tubes of White, Black, Yellow, Ochre, Vermilion, Burnt Sienna, Carmine, Purple, Violet, Ultramarine, Cobalt Blue, and Emerald Green, plus a #5 round camel hair brush.

NUMBER	EACH	6/EA
A00822-0139	\$69.26	\$62.33

5-Color Set — Includes 0.34 oz (10 ml) tubes of Magenta, Cyan, Yellow, Black, and White.

NUMBER	EACH	6/EA
A00822-1059	\$27.66	\$24.89



M. Graham Artists' Gouache Basic Set

An excellent mixing palette, this set contains five 0.5 oz (15 ml) colors including Azo Yellow, Naphthol Red, Cobalt Blue, Ivory Black, and Titanium White.

NUMBER	EACH	6/EA
A00818-0059	\$48.26	\$43.43



Set of 20

Set of 10

Savoir Faire Opaque Watercolor Gouache Sets

Vibrant, versatile, and easy to use, these waterbased gouache paints are ideal for students and artists of all ages. 0.33 oz (10 ml) tubes.

NUMBER	DESCRIPTION	EACH	10/EA
A00803-0029	Set of 10	\$17.99	\$16.21
A00803-0049	Set of 20	24.99	22.51

Royal Talens™ Gouache

Royal Talens Gouache is made with a unique dextrin-based binder that sets it apart from most other brands. It becomes more fluid as it's mixed, allowing you to cover large areas more evenly. It's also an incredible value. Made in Holland. Colors can be assorted for quantity pricing.

0.66 oz (20 ml) Tubes

NUMBER	COLOR	EACH	12/EA
A00826-5911	Azure Blue	\$9.53	\$8.57
A00826-2291	Black Intenso	9.53	8.57
A00826-5391	Blue Violet	9.53	8.57
A00826-3731	Bordeaux	9.53	8.57
A00826-8151	Bronze	9.53	8.57
A00826-8041	Burnt Sienna	9.53	8.57
A00826-8051	Burnt Umber	9.53	8.57
A00826-3151	Carmine	9.53	8.57
A00826-5161	Cerulean Blue	9.53	8.57
A00826-5181	Cobalt Blue	9.53	8.57
A00826-2801	Cool Gray	9.53	8.57
A00826-9501	Copper	9.53	8.57
A00826-8811	Deep Brown	9.53	8.57
A00826-9161	Deep Gold	9.53	8.57
A00826-7041	Deep Green	9.53	8.57
A00826-3711	Deep Red	9.53	8.57
A00826-3461	Deep Rose Magenta	9.53	8.57
A00826-4031	Deep Yellow	9.53	8.57
A00826-7051	Emerald Green	9.53	8.57
A00826-7191	Fir Green	9.53	8.57
A00826-7001	Green	9.53	8.57
A00826-7901	Greenish Yellow	9.53	8.57
A00826-8221	Havana Brown	9.53	8.57
A00826-4061	Lemon Yellow	9.53	8.57
A00826-5021	Light Blue	9.53	8.57
A00826-8011	Light Brown	9.53	8.57
A00826-9011	Light Gold	9.53	8.57
A00826-7011	Light Green	9.53	8.57
A00826-4511	Light Orange	9.53	8.57
A00826-3721	Light Oxide Red	9.53	8.57
A00826-3011	Light Red	9.53	8.57
A00826-4011	Light Yellow	9.53	8.57
A00826-6031	Lilac	9.53	8.57
A00826-4141	Naples Yellow	9.53	8.57
A00826-4151	Naples Yellow Red	9.53	8.57
A00826-2541	Neutral Black	9.53	8.57
A00826-7071	Olive Green	9.53	8.57
A00826-1081	Opaque White Extra	9.53	8.57
A00826-4501	Orange	9.53	8.57
A00826-5891	Orient Blue	9.53	8.57
A00826-3261	Perm Rose Crimson	9.53	8.57
A00826-5221	Prussian Blue	9.53	8.57
A00826-8061	Raw Sienna	9.53	8.57
A00826-8071	Raw Umber	9.53	8.57
A00826-3761	Red Violet	9.53	8.57
A00826-3171	Rose	9.53	8.57
A00826-3081	Scarlet	9.53	8.57
A00826-8081	Sepia	9.53	8.57
A00826-9331	Silver	9.53	8.57
A00826-5111	Turquoise Blue	9.53	8.57
A00826-7911	Turquoise Green	9.53	8.57
A00826-5251	Ultramarine Deep	9.53	8.57
A00826-5301	Ultramarine Light	9.53	8.57
A00826-3281	Vermilion	9.53	8.57
A00826-6511	Violet	9.53	8.57
A00826-7481	Viridian	9.53	8.57
A00826-2321	Warm Gray	9.53	8.57
A00826-1021	White	9.53	8.57
A00826-4001	Yellow	9.53	8.57
A00826-4041	Yellow Ochre	9.53	8.57

Set of 5 — White, Lemon Yellow, Permanent Rose, Light Blue, and Black Intenso in 0.68 oz (20 ml) tubes.

NUMBER	EACH	6/EA
A00826-1059	\$47.88	\$43.08

Set of 8 — White, Yellow, Lemon Yellow, Permanent Rose, Vermilion, Light Blue, Ultramarine Deep, and Black Intenso in 0.68 oz (20 ml) tubes.

NUMBER	EACH	6/EA
A00826-1089	\$71.30	\$64.16

Winsor & Newton™ Designers Gouache

Introduced in 1935, this is one of the finest artists' gouache ranges available. Today, thanks to significant developments in technology, they are smoother, flatter, more opaque, and more brilliant than ever before.

0.47 oz (14 ml) Tubes

NUMBER	COLOR	EACH
A00801-3062	Alizarin Crimson	\$9.53
A00801-3722	Bengal Rose	11.85
A00801-7472	Brilliant Green	9.53
A00801-6072	Brilliant Purple	11.85
A00801-3702	Brilliant Red Violet	9.53
A00801-6532	Brilliant Violet	9.53
A00801-4932	Brilliant Yellow	15.22
A00801-8042	Burnt Sienna	9.53
A00801-8052	Burnt Umber	9.53
A00801-4172	Cadmium-Free Lemon	22.79
A00801-4512	Cadmium-Free Orange	22.79
A00801-3322	Cadmium-Free Red	22.79
A00801-3552	Cadmium-Free Scarlet	22.79
A00801-4192	Cadmium-Free Yellow	22.79
A00801-4112	Cadmium-Free Yellow Dp	22.79
A00801-4292	Cadmium-Free Yellow Pl	22.79
A00801-4182	Cadmium Lemon	22.79
A00801-4532	Cadmium Orange	22.79
A00801-3332	Cadmium Red	22.79
A00801-3562	Cadmium Scarlet	22.79
A00801-4202	Cadmium Yellow	22.79
A00801-4122	Cadmium Yellow Deep	22.79
A00801-4302	Cadmium Yellow Pale	22.79
A00801-5162	Cerulean Blue	22.79
A00801-5182	Cobalt Blue	22.79
A00801-5932	Cobalt Turquoise Light	22.79
A00801-7902	Cyprus Green	11.85
A00801-3572	Flame Red	9.53
A00801-9012	Gold	15.22
A00801-9032	Gold Ochre	9.53
A00801-5202	Indigo	9.53
A00801-5812	Intense Blue	11.85
A00801-2252	Ivory Black	9.53
A00801-2032	Jet Black	9.53
A00801-2022	Lamp Black	9.53
A00801-4062	Lemon Yellow	9.53
A00801-6012	Light Purple	11.85
A00801-7922	Linden Green	11.85
A00801-3042	Magenta	11.85
A00801-4742	Marigold Yellow	9.53
A00801-4142	Naples Yellow	9.53
A00801-4522	Naples Yellow Deep	9.53
A00801-2542	Neutral Gray 3	9.53
A00801-7072	Olive Green	11.85
A00801-3782	Opera Pink	11.85
A00801-3182	Opera Rose	11.85
A00801-4912	Orange Lake Deep	9.53
A00801-4922	Orange Lake Light	9.53
A00801-7372	Oxide of Chromium	11.85
A00801-3842	Pale Rose Blush	9.53
A00801-3392	Perm Alizarin Crim	15.22
A00801-7082	Perm Green Deep	11.85
A00801-7312	Perm Green Light	11.85
A00801-7792	Perm Green Med	11.85
A00801-3192	Perm Rose	15.22
A00801-1172	Perm White	9.53
A00801-4872	Perm Yellow Deep	9.53
A00801-2262	Perylene Black	15.22
A00801-3342	Perylene Maroon	15.22
A00801-6932	Perylene Violet	15.22
A00801-5102	Phthalo Blue	9.53

Pebeo Studio Gouache

Concentrated, lively, and highly pigmented, these water-soluble colors lay down beautifully, whether applied in thick, opaque strokes or thin, transparent washes. They dry to a smooth, velvety matte finish.

NUMBER	COLOR	EACH
A00828-8701	Burnt Sienna	\$11.55
A00828-8051	Burnt Umber	11.55
A00828-3111	Cadmium Red Imitation	11.55
A00828-3151	Carmine	11.55
A00828-5391	Cobalt Blue Imitation	11.55
A00828-7051	Emerald Green	11.55
A00828-9001	Gold	11.55
A00828-5101	Iridescent Blue Green	11.34
A00828-5021	Iridescent Blue Parma	11.34
A00828-2251	Ivory Black	11.55
A00828-4061	Lemon Yellow	11.55



0.47 oz (14 ml) Tubes

NUMBER	COLOR	EACH
A00801-5922	Primary Blue	\$9.53
A00801-3742	Primary Red	9.53
A00801-4542	Primary Yellow	9.53
A00801-5222	Prussian Blue	9.53
A00801-3622	Quinacridone Magenta	15.22
A00801-8062	Raw Sienna	9.53
A00801-8072	Raw Umber	9.53
A00801-3682	Red Ochre	9.53
A00801-3762	Rose Tyrien	11.85
A00801-7092	Sap Green	11.85
A00801-8082	Sepia	9.53
A00801-9332	Silver	15.22
A00801-5072	Sky Blue	9.53
A00801-3772	Spectrum Red	9.53
A00801-6912	Spectrum Violet	9.53
A00801-4952	Spectrum Yellow	9.53
A00801-5112	Turquoise Blue	11.85
A00801-5252	Ultramarine	9.53
A00801-7942	Ultramarine (GS)	9.53
A00801-8312	Van Dyke Brown	9.53
A00801-3132	Venetian Red	9.53
A00801-7102	Viridian	15.22
A00801-5642	Winsor Blue	15.22
A00801-7442	Winsor Green	15.22
A00801-3792	Winsor Red	15.22
A00801-6742	Winsor Violet Dioxazine	15.22
A00801-4042	Yellow Ochre	9.53
A00801-1032	Zinc White	9.53

37 ml (1.25 oz) Tubes

NUMBER	COLOR	EACH
A00801-2253	Ivory Black	\$21.88
A00801-2033	Jet Black	21.88
A00801-2023	Lamp Black	21.88
A00801-1173	Permanent White	21.88
A00801-1033	Zinc White	21.88

Winsor & Newton™ Designers Gouache Sets

Introductory Set — Contains 10, 0.47 oz (14 ml) tubes of the most popular colors: Zinc White, Yellow Ochre, Ultramarine, Spectrum Red, Primary Yellow, Primary Red, Primary Blue, Permanent Yellow Deep, Ivory Black, and Permanent Green Medium.

NUMBER	EACH
A00801-1029	\$81.55

Primary Color Set — Contains six 0.47 oz (14 ml) tubes ideal for color mixing: Primary Yellow, Primary Red, Primary Blue, Permanent Green Medium, Ivory Black, and Zinc White.

NUMBER	EACH
A0	

BLICKRYLIC® sets and mediums



Basic

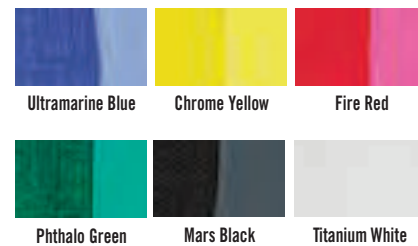

Mixing

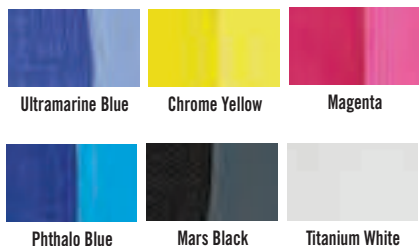

Fluorescent

Colors may vary

Primary

Blickrylic® Sets of 6

Fluorescent — Fluorescent Yellow, Fluorescent Yellow-Orange, Fluorescent Red, Fluorescent Pink, Fluorescent Green, and Fluorescent Blue.

NUMBER	DESCRIPTION	SIZE	EACH
A00711-1069	Fluorescent	2 oz	\$13.03

Metallic — Brass, Copper, Silver, Gold, Titanium White, and Mars Black.

NUMBER	DESCRIPTION	SIZE	EACH
A00711-1029	Metallic	2 oz	\$13.03

Primary — Titanium White, Chrome Yellow, Fire Red, Phthalo Green, Ultramarine Blue, and Mars Black.

NUMBER	DESCRIPTION	SIZE	EACH
A00711-9019	Primary	2 oz	\$13.03

Blickrylic® 6-Pack of Pints

A convenient carry carton of six flip-top pints (437 ml).

Basic Color Set — Ultramarine Blue, Chrome Yellow, Fire Red, Phthalo Green, Mars Black, and Titanium White.

NUMBER	EACH
A00711-1049	\$34.92

Mixing Color Set — Chrome Yellow, Magenta, Ultramarine Blue, Phthalo Blue, Mars Black, and Titanium White.

NUMBER	EACH
A00711-1039	\$34.92



Blickrylic® Color Mixing Class Pack

A color theory class in a box, with enough supplies for 20 students. It includes:

- 5 Quarts (946 ml) of Blickrylic (Chrome Yellow, Magenta, Ultramarine Blue, Titanium White, and Mars Black)
- 20 Blick Scholastic Golden Taklon Bright Size 6 brushes
- 20 Create-A-Color uncoated color wheels
- 20 plastic painting knives for mixing colors
- 20 plastic painting trays

NUMBER	EACH
A00734-1009	\$216.64



Blickrylic® Mediums

Blickrylic Mediums are non-toxic and can be mixed with other brands of acrylic.

Blickrylic Gesso — Apply it as a ground to improve adherence of Blickrylic and other polymer acrylic paints.

NUMBER	SIZE	EACH	4/EA	12/EA
A00711-1016	Pint (473 ml)	\$9.76	\$8.78	\$8.34
A00711-1017	Quart (946 ml)	16.59	14.93	14.18
A00711-1059	Gallon (3.79 Liter)	37.10	33.38	31.71

Blickrylic Gel Medium — For glazing, texturing, and impasto effects.

NUMBER	SIZE	EACH	4/EA	12/EA
A00711-1006	Pint (473 ml)	\$11.82	\$10.49	\$9.96
A00711-1007	Quart (946 ml)	19.55	17.62	15.85
A00711-1018	Half Gallon (1.89 Liter)	23.56	21.19	19.99

Blickrylic Polymer Gloss Medium — Apply a gloss medium over your painting to produce a glossy surface rather than a matte surface.

NUMBER	SIZE	EACH	4/EA	12/EA
A00711-1026	Pint (473 ml)	\$11.82	\$10.49	\$9.96
A00711-1027	Quart (946 ml)	19.55	17.62	15.85
A00711-1028	Half Gallon (1.89 Liter)	23.56	21.19	19.99

Try Blickrylic® Mixing Colors Great for Teaching Color Theory

Blickrylic® Student Acrylics

A true acrylic paint, priced for the budget-minded. Extremely pourable and non-toxic, versatile Blickrylic is great for an unlimited range of projects. Brighten up artwork on paper, canvas, wood, and cardboard — you can even use it on T-shirts when properly heat-set with an iron. It's mixable with other brands of acrylic and dries quickly to a permanent, waterproof, semi-gloss finish. Caution: Blickrylic will stain clothing if not washed out immediately.

Colors can be assorted for quantity pricing.

COLOR	PINT (473 ML)	QUART (946 ML)	HALF GALLON (1.89 LITER)
Blockout White	A00711-1086	A00711-1087	A00711-1088
Bright Red	A00711-3076	A00711-3077	A00711-3078
Burnt Sienna	A00711-8046	A00711-8047	A00711-8048
Burnt Umber	A00711-8056	A00711-8057	A00711-8058
Chrome Orange	A00711-4666	A00711-4667	A00711-4668
Chrome Yellow	A00711-4156	A00711-4157	A00711-4158
Cobalt Blue	A00711-5186	A00711-5187	A00711-5188
Deep Yellow	A00711-4326	A00711-4327	A00711-4328
Fire Red	A00711-3116	A00711-3117	A00711-3118
Green Oxide	A00711-7296	A00711-7297	A00711-7298
Magenta	A00711-3046	A00711-3047	A00711-3048
Mars Black	A00711-2046	A00711-2047	A00711-2048
Phthalo Blue	A00711-5146	A00711-5147	A00711-5148
Phthalo Green	A00711-7066	A00711-7067	A00711-7068
Phthalo Red	A00711-3406	A00711-3407	A00711-3408
Primary Blue	A00711-5016	A00711-5017	A00711-5018
Primary Magenta	A00711-3766	A00711-3767	A00711-3768
Primary Yellow	A00711-4016	A00711-4017	A00711-4018
Raw Sienna	A00711-8066	A00711-8067	A00711-8068
Raw Umber	A00711-8076	A00711-8077	A00711-8078
Titanium White	A00711-1116	A00711-1117	A00711-1118
Turquoise	A00711-5116	A00711-5117	A00711-5118
Ultramarine Blue	A00711-5236	A00711-5237	A00711-5238
Venetian Red	A00711-3136	A00711-3137	A00711-3138
Violet	A00711-6506	A00711-6507	A00711-6508
	EACH \$6.75	EACH \$11.06	EACH \$18.78
	12/EA 6.24	12/EA 9.96	6/EA 17.15
	24/EA 5.85	24/EA 9.41	12/EA 16.29

Fluorescent Colors

COLOR	PINT (473 ML)	QUART (946 ML)	HALF GALLON (1.89 LITER)
Fluorescent Blue	A00711-5246	A00711-5247	A00711-5248
Fluorescent Green	A00711-7266	A00711-7267	A00711-7268
Fluorescent Magenta	A00711-3056	A00711-3057	A00711-3058
Fluorescent Orange	A00711-4556	A00711-4557	A00711-4558
Fluorescent Pink	A00711-3486	A00711-3487	A00711-3488
Fluorescent Red	A00711-3216	A00711-3217	A00711-3218
Fluorescent True Red	A00711-3716	A00711-3717	A00711-3718
Fluorescent Violet	A00711-6916	A00711-6917	A00711-6918
Fluorescent Yellow	A00711-4216	A00711-4217	A00711-4218
Fluorescent Ylw-Orng	A00711-4286	A00711-4287	A00711-4288
	EACH \$6.93	EACH \$11.68	EACH \$19.88
	12/EA 6.24	12/EA 10.58	6/EA 17.90
	24/EA 5.92	24/EA 9.48	12/EA 16.94

Metallic Colors

COLOR	PINT (473 ML)	QUART (946 ML)	HALF GALLON (1.89 LITER)
Metallic Brass	A00711-9076	A00711-9077	A00711-9078
Metallic Copper	A00711-9516	A00711-9517	A00711-9518
Metallic Silver	A00711-9326	A00711-9327	A00711-9328
Metallic Gold	A00711-9086	A00711-9087	A00711-9088
	EACH \$8.65	EACH \$15.27	EACH \$26.19
	12/EA 7.75	6/EA 14.24	6/EA 22.66
	24/EA 7.37	12/EA 13.75	12/EA 21.53



Lockable Pump Lids

Dispense paints neatly and easily. The locking mechanism keeps paint inside the containers, and keeps containers clean. Created for use with Blick Tempera paints and Blickrylics ½ and 1 gallon containers.

NUMBER	SIZE	EACH	12/EA
A02909-1009	Gallon	\$3.38	\$3.04
A02909-0080	Half Gallon	3.38	3.04



Color swatches are full strength and 50% tint.

Fluorescent Colors



Metallic Colors



SARGENT ART



Sargent Art Acrylic Paint

Affordably priced and perfect for classrooms, this paint is non-toxic, non-separating, and odor free. Use the permanent, opaque colors for a variety of projects, from painting to printmaking.

Colors can be assorted for quantity pricing.

COLOR	16 OZ (473 ML)	HALF GALLON (1.89 L)
Black	A01643-2026	A01643-2258
Blue	A01643-5016	A01643-5238
Brown	A01643-8006	A01643-8008
Green	A01643-7016	A01643-7028
Magenta	A01643-3046	A01643-3048
Orange	A01643-4516	A01643-4528
Peach	A01643-3356	A01643-3358
Red	A01643-3016	A01643-3028
Turquoise	A01643-5116	A01643-5118
Violet	A01643-6516	A01643-6528
White	A01643-1026	A01643-1028
Yellow	A01643-4016	A01643-4028
	EACH 12/EA	EACH 6/EA
	\$9.64 \$8.68	\$27.58 \$24.79

COLOR	NUMBER
Neon Blue	A01643-5245
Neon Chartreuse	A01643-7635
Neon Green	A01643-7275
Neon Orange	A01643-4565
Neon Pink	A01643-3725
Neon Red	A01643-3215
Neon Yellow	A01643-4225
Neon Yellow Orange	A01643-4915
	EACH 12/EA
	\$9.64 \$8.68

For 32 oz (946 ml) Bottles, visit DickBlick.com.

Tri-Art™ UVFX Black Light Poster Paint

Ideal for scenic painting, posters, and fine art pieces, these paints glow under black light, letting you create dynamic visual effects. Non-toxic. Colors can be assorted for quantity pricing.

COLOR	4 OZ (120 ML)	8.5 OZ (250 ML)
Black	A02043-2029	A02043-2026
Fluorescent Blue	A02043-5249	A02043-5246
Fluorescent Green	A02043-7269	A02043-7266
Fluorescent Orange	A02043-4569	A02043-4566
Fluorescent Pink	A02043-3719	A02043-3716
Fluorescent Red	A02043-3219	A02043-3216
Fluorescent Tangerine	A02043-4639	A02043-4636
Fluorescent Violet	A02043-6419	A02043-6416
Fluorescent Yellow	A02043-4229	A02043-4226
Glow in the Dark	A02043-1009	A02043-1006
	EACH 12/EA	EACH 12/EA
	\$13.74 \$12.36	\$23.97 \$21.57

Sampler Set — 1.25 oz (37 ml) jars of Fluorescent Red, Fluorescent Orange, Fluorescent Green, Fluorescent Yellow, Fluorescent Black, and Glow in the Dark, plus a 4 oz (120 ml) jar of Black Light Medium. Packaged in a reusable container that doubles as a water cup.

NUMBER	EACH	NUMBER	EACH
A02043-1019	\$33.09	A00648-1060	\$31.55 \$28.39



Sargent Art Pearlescent and Glitter Acrylic Mediums

Pearlescent Mixing Medium — Produce pearlescent paint effects by mixing with small amounts of acrylic paint. 16 oz (473 ml) bottle.

NUMBER	SIZE	EACH	12/EA
A00733-1006	16 oz	\$11.46	\$10.31
A00704-1009	Gallon (3.78 Liter)	95.19	85.68

Glitter Glaze — Use alone or over any acrylic paint for an exciting glitter effect. 16 oz (473 ml) bottle.

NUMBER	SIZE	EACH	12/EA
A00704-1006	16 oz (473 ml)	\$21.53	\$19.37



Sargent Art Liquid Metal Acrylics

Brilliant metallic colors create sensational sparkle and dry to a permanent finish. Colors can be assorted for quantity pricing.

COLOR	8 OZ (237 ML)	GALLON (3.76 L)
	BOTTLES	BOTTLES
Antique Gold	A00730-9135	—
Aztec Gold	A00730-9035	—
Bronze	A00730-9605	—
Copper	A00730-9505	—
Gold	A00730-9015	A00730-9018
Silver	A00730-9335	A00730-9338
	EACH 6/EA	EACH 6/EA
	\$10.59 \$9.13	\$75.90 \$68.31

4 oz (118 ml) Jars

COLOR	NUMBER
Blue	A00730-5014
Gold	A00730-9014
Green	A00730-7014
Red	A00730-3014
Silver	A00730-9334
Violet	A00730-6514

NUMBER	EACH	12/EA
A00730-5014	\$5.89	\$5.30



Sargent Art Acrylic Paint Pot Sets

Sets contain 0.75 oz (22 ml) paint pots.

Basic Colors, Set of 6 — Yellow, Blue, Green, Red, White, and Black.

NUMBER	EACH	12/EA
A00732-0069	\$5.95	\$5.04

Basic Colors, Set of 12 — All colors above plus Violet, Orange, Brown, Magenta, Turquoise Blue, and Peach.

NUMBER	EACH	12/EA
A00732-1129	\$11.60	\$9.99



Sargent Art Acrylic Set of 12 Tubes

Includes Titanium White, Lemon Yellow, Vermillion, Yellow Ochre, Crimson Red, Grass Green, Viridian Green, Ultramarine Blue, Phthalo Blue, Burnt Sienna, Burnt Umber, and Black in 0.4 oz (12 ml) tubes.

NUMBER	EACH	12/EA
A01645-0129	\$7.09	\$5.55



Crayola Portfolio Series Acrylics

Ideal for traditional acrylic painting and applications as varied as airbrushing, printmaking, and marbling. Adheres permanently to paper, wood, fabric, and clay. Colors can be assorted for quantity pricing.

16 oz (473 ml) Bottles

COLOR	NUMBER	EACH	12/EA
Brilliant Blue	A00629-5066		
Brilliant Blue Purple	A00629-6086		
Brilliant Orange	A00629-4596		
Brilliant Yellow	A00629-4936		
Burnt Sienna	A00629-8046		
Burnt Umber	A00629-8536		
Bronze Yellow	A00629-4916		
Deep Magenta	A00629-3046		
Deep Red	A00629-3716		
Ivory Black	A00629-2256		
Light Green	A00629-7016		
Light Red	A00629-3016		
Pearl Mix Medium	A00629-1606		
Phthalo Blue	A00629-5756		
Phthalo Green	A00629-7806		
Titanium White	A00629-1016		
Turner Yellow	A00629-4416		
Violet	A00629-6056		
		EACH	12/EA
		\$11.99	\$10.79



NEW! Tri-Art™ Art Noise Permanent Acrylic Gouache

NUMBER	COLOR	EACH	6/EA
A01640-7135	Aubergine	\$12.51	\$11.26
A01640-5065	Bright Blue	12.51	11.26
A01640-6075	Brilliant Purple	12.51	11.26
A01640-3085	Burnt Scarlet	17.74	15.97
A01640-8045	Burnt Sienna	12.51	11.26
A01640-8055	Burnt Umber	12.51	11.26
A01640-2125	Carbon Black	12.51	11.26
A01640-3245	Coral	12.51	11.26
A01640-7055	Emerald	12.51	11.26
A01640-8225	Hemp	12.51	11.26
A01640-7505	Hunter Green	12.51	11.26
A01640-1045	Ivory	12.51	11.26
A01640-6045	Lavender	12.51	11.26
A01640-4925	Lemon Butter	12.51	11.26
A01640-3015	Light Red	17.74	15.97
A01640-7235	Lime Green	17.74	15.97
A01640-3585	Magenta Light	12.51	11.26
A01640-7525	Moss Green	12.51	11.26
A01640-4145	Naples Yellow	12.51	11.26



Daler-Rowney Graduate Acrylics

Fast-drying, durable, and flexible when dry, Daler-Rowney Graduate Acrylics are a great value for the classroom. Colors can be assorted for quantity pricing.

NUMBER	COLOR	EACH	6/EA
A01638-2025	Black	\$16.62	\$14.96
A01638-8625	Buff Titanium	16.62	14.96
A01638-8045	Burnt Sienna	16.62	14.96
A01638-8055	Burnt Umber	16.62	14.96
A01638-4545	Cadmium Orange Hue	16.62	14.96
A01638-3325	Cadmium Red Dp Hue	16.62	14.96
A01638-3545	Cadmium Red Hue	16.62	14.96
A01638-4355	Cadmium Yellow Hue	16.62	14.96
A01638-4125	Cadmium Ylw Dp Hue	16.62	14.96
A01638-3165	Cobalt Blue Hue	16.62	14.96
A01638-5095	Coeruleum Blue Hue	16.62	14.96
A01638-3455	Crimson	16.62	14.96
A01638-7055	Emerald Green	16.62	14.96
A01638-9045	Gold Imitation	16.62	14.96
A01638-7125	Hooker's Green	16.62	14.96
A01638-5205	Indigo	16.62	14.96
A01638-7155	Leaf Green	16.62	14.96
A01638-4065	Lemon Yellow	16.62	14.96
A01638-5545	Metallic Blue	16.62	14.96
A01638-8455	Metallic Brown	16.62	14.96
A01638-7845	Metallic Green	16.62	14.96
A01638-3795	Metallic Pink	16.62	14.96
A01638-3715	Metallic Red	16.62	14.96
A01638-4765	Metallic Yellow	16.62	14.96
A01638-1305	Mixing White	16.62	14.96
A01638-4145	Naples Yellow	16.62	14.96
A01638-2545	Neutral Gray	16.62	14.96
A01638-2565	Payne's Grey	16.62	14.96
A01638-2415	Pearl Black	16.62	14.96
A01638-1095	Pearl White	16.62	14.96
A01638-3265	Permanent Rose	16.62	14.96
A01638-5165	Phthalo Blue	16.62	14.96
A01638-7805	Phthalo Green	16.62	14.96
A01638-5425	Phthalo Turquoise	16.62	14.96
A01638-3725	Peach Pink	16.62	14.96
A01638-5925	Primary Blue	16.62	14.96
A01638-3745	Primary Red	16.62	14.96
A01638-4535	Primary Yellow	16.62	14.96
A01638-6005	Purple	16.62	14.96
A01638-8075	Raw Umber	16.62	14.96
A01638-7095	Sap Green	16.62	14.96
A01638-9335	Silver Imitation	16.62	14.96
A01638-5135	Ultramarine Blue	16.62	14.96
A01638-3135	Venetian Red	16.62	14.96
A01638-3425	Vermilion Hue	16.62	14.96
A01638-6515	Violet	16.62	14.96
A01638-1025	White	16.62	14.96
A01638-4045	Yellow Ochre	16.62	14.96

Talens Art Creation Acrylic Sets

Perfect starter sets (and gifts!) for students and aspiring artists. This versatile paint is great for use on canvas paper, plaster, board, wood, stone, and cement. It's easy to thin and cleans up with water. It has a pasty texture with a silky sheen when dry. 0.41 oz (12 ml) tubes.

Set of 12 — Titanium White, Primary Yellow, Azo Yellow Deep, Naphthol Red Medium, Primary Magenta, Ultramarine, Primary Cyan, Permanent Green Deep, Yellow Ochre, Burnt Sienna, Burnt Umber, and Ivory Black.

NUMBER	EACH	6/EA
A01696-1129	\$10.98	\$9.89

Set of 24 — The colors in the Set of 12, plus Azo Yellow Lemon, Azo Orange, Carmine, Permanent Red Violet, Permanent Blue Violet, Cobalt Blue (Ultramarine), Phthalo Blue, Brilliant Blue, Turquoise Green, Yellowish Green, Permanent Green Light, and an extra tube of Titanium White.

NUMBER	EACH	3/EA
A01696-1249	\$21.14	\$18.99

16.9 oz (500 ml)

NUMBER	COLOR	EACH	6/EA
A01640-2545	Neutral Grey	\$12.51	\$11.26
A01640-7075	Olive Green	12.51	11.26
A01640-4515	Orange	17.74	15.97
A01640-3755	Pastel Rose	12.51	11.26
A01640-3565	Paynes Grey	12.51	11.26
A01640-5775	Periwinkle	12.51	11.26
A01640-5595	Primary Cyan	12.51	11.26
A01640-4535	Primary Yellow	12.51	11.26
A01640-5225	Prussian Blue	12.51	11.26
A01640-3765	Pyrrrole Red	17.74	15.97
A01640-3125	Red Oxide Tint	12.51	11.26
A01640-3725	Rose Deep	12.51	11.26
A01640-7425	Seafoam Green	12.51	11.26
A01640-5075	Sky Blue	12.51	11.26
A01640-2605	Slate	12.51	11.26
A01640-5085	Teal	12.51	11.26
A01640-1025	Titanium White	17.74	15.97
A01640-5005	Transparent Blue	12.51	11.26
A01640-3705	Transparent Crimson	12.51	11.26
A01640-5205	Transparent Deep Blue	12.51	11.26
A01640-7865	Transparent Green	12.51	11.26
A01640-3745	Transparent Magenta	12.51	11.26
A01640-4955	Transparent Orange	17.74	15.97
A01640-6005	Transparent Purple	12.51	11.26
A01640-3735	Transparent Red	12.51	11.26
A01640-5865	Transparent Turquoise	12.51	11.26
A01640-4985	Transparent Yellow	17.74	15.97
A01640-4115	Turmeric	17.74	15.97
A01640-5115	Turquoise	12.51	11.26
A01640-6645	Ultra Violet	12.51	11.26
A01640-4045	Yellow Ochre	12.51	11.26



Crayola Signature Acrylic Paint Sets

Superior coverage and maximum blendability! These sets make great gifts for the young artist in your life. They include 16 highly pigmented acrylic colors in 0.4 oz (12 ml) tubes, removable mixing wells, and a decorative storage tin.

NUMBER	DESCRIPTION	EACH	6/EA
A01693-1169	Set of 16	\$20.97	\$18.87
A01693-2169	Pearlescent Set of 16	20.97	18.87

CREATEX



Createx Acrylics

The student paint that stands up to the professionals! This permanent, medium-bodied, waterbased acrylic is suitable for a variety of studio and classroom applications. Use Createx Acrylics with confidence for painting on canvas, murals, fabric (must be heat set), ceramicware, or paper. It even works on leather, cement, papier mâché, wood, and as a screen printing ink. **Colors can be assorted for quantity pricing.**

COLOR	16 OZ (473 ML) BOTTLES		32 OZ (946 ML) BOTTLES	
	EACH	20/EA	EACH	12/EA
Burnt Sienna	\$15.52	\$13.97	\$28.98	\$26.49
Burnt Umber	15.52	13.97	28.98	26.49
Carbazole Violet	15.52	13.97	28.98	26.49
Carbon Black	15.52	13.97	28.98	26.49
Cerulean Blue	15.52	13.97	28.98	26.49
Chrome Oxide Green	15.52	13.97	28.98	26.49
Cobalt Blue	15.52	13.97	28.98	26.49
Golden Yellow	15.52	13.97	28.98	26.49
Hansa Yellow Medium	15.52	13.97	28.98	26.49
Iridescent Electric Blue	42.18	37.96	82.75	75.60
Iridescent Bright Red	42.18	37.96	82.75	75.60
Iridescent Fuchsia	42.18	37.96	82.75	75.60
Iridescent Yellow	42.18	37.96	82.75	75.60
Orange	15.52	13.97	28.98	26.49
Pearl Blue	22.34	20.11	41.95	38.31
Pearl Copper	22.34	20.11	41.95	38.31
Pearl Green	22.34	20.11	41.95	38.31
Pearl Lime Green	22.34	20.11	41.95	38.31
Pearl Magenta	22.34	20.11	41.95	38.31
Pearl Orange	22.34	20.11	41.95	38.31
Pearl Purple	22.34	20.11	41.95	38.31
Pearl Satin Gold	22.34	20.11	41.95	38.31
Pearl Silver	22.34	20.11	41.95	38.31
Pearl White	22.34	20.11	41.95	38.31
Permanent Light Green	15.52	13.97	28.98	26.49
Phthalo Blue GS	15.52	13.97	28.98	26.49
Phthalo Green RS	15.52	13.97	28.98	26.49
Primary Red	15.52	13.97	28.98	26.49
Quinacridone Crimson	15.52	13.97	28.98	26.49
Quinacridone Magenta	15.52	13.97	28.98	26.49
Raw Sienna	15.52	13.97	28.98	26.49
Scarlet	15.52	13.97	28.98	26.49
Titanium White	15.52	13.97	28.98	26.49
Turquoise Hue	15.52	13.97	28.98	26.49
Ultramarine Blue	15.52	13.97	28.98	26.49
Yellow Oxide	15.52	13.97	28.98	26.49

Set of 8 Colors — Includes Primary Red, Hansa Yellow, Phthalo Blue, White, Black, Burnt Umber, Phthalo Green, and Pearl Satin Gold.

NUMBER	DESCRIPTION	EACH	3/EA
A01210-0816	16 oz Bottles	\$124.42	\$111.98
A01210-0832	32 oz Bottles	224.71	202.22

Set of 12 Colors — Includes the eight colors listed to the left, plus Magenta, Orange, Cobalt Blue, and Violet.

NUMBER	DESCRIPTION	EACH	3/EA
A01210-1216	16 oz Bottles	\$183.41	\$165.07
A01210-1232	32 oz Bottles	343.00	309.00



Chroma Molten Metals Acrylics

Metallic acrylics can be lightly sponged or brushed full strength onto highlighted areas for a shimmering, silky finish. Or mix them with other colors for a more subtle effect. Superb coverage and versatility. Water-resistant and quick-drying. **Colors can be assorted for quantity pricing.**

NUMBER	COLOR	EACH	12/EA
A00688-8155	Aged Bronze	\$4.87	\$4.39
A00688-9505	Copper	4.87	4.39
A00688-9016	Dorado Gold	4.87	4.39
A00688-7058	Emerald Green	4.87	4.39
A00688-6178	Plum Purple	4.87	4.39
A00688-9335	Purgare Silver	4.87	4.39
A00688-5728	Regale Blue	4.87	4.39
A00688-9017	Rojo Gold	4.87	4.39
A00688-3378	Ruby Red	4.87	4.39
A00688-9015	Xanadu Gold	4.87	4.39

Set of 4 — Includes 8.4 oz (250 ml) bottles of Aged Bronze, Copper, Purgare Silver, and Xanadu Gold.

NUMBER	EACH	12/EA
A00688-1049	\$18.65	\$16.78

Set of 6 — Includes 8.4 oz (250 ml) bottles of Aged Bronze, Copper, Dorado Gold, Purgare Silver, Rojo Gold, and Xanadu Gold.

NUMBER	EACH	12/EA
A00688-1089	\$23.20	\$20.87

DecoArt Americana Acrylic Paints

Great for pros, students, and crafters, these premium acrylics deliver superior coverage with a permanent, durable matte finish. They're made with bright, lightfast pigments. Intermixable, waterbased, and non-toxic. Use them on almost any surface. **Colors can be assorted for quantity pricing.**

NUMBER	COLOR	EACH	6/EA
A00769-3533	Alizarin Crimson Trans	\$2.78	\$2.50
A00769-4573	Antique Gold	2.78	2.50
A00769-5353	Baby Blue	2.78	2.50
A00769-1163	Baby Pink	2.78	2.50
A00769-5913	Bahama Blue	2.78	2.50
A00769-4513	Bright Orange	2.78	2.50
A00769-4293	Bright Yellow Trans	2.78	2.50
A00769-1133	Bubblegum Pink	2.78	2.50
A00769-4703	Burnt Orange	2.78	2.50
A00769-8713	Burnt Sienna	2.78	2.50
A00769-8053	Burnt Umber	2.78	2.50
A00769-1123	Buttermilk	2.78	2.50
A00769-4353	Cad Yellow Hue Trans	2.78	2.50
A00769-5933	Calypso Blue	2.78	2.50
A00769-1153	Carousel Pink	2.78	2.50
A00769-3453	Cherry Red	2.78	2.50
A00769-7913	Citron Green Trans	2.78	2.50
A00769-3763	Coral Blush	2.78	2.50
A00769-3313	Cranberry Wine	2.78	2.50
A00769-8103	Dark Chocolate	2.78	2.50
A00769-3733	Deep Burgundy	2.78	2.50
A00769-5803	Deep Midnight Blue	2.78	2.50
A00769-5183	Desert Turquoise	2.78	2.50
A00769-6023	Dioxazine Purple	2.78	2.50
A00769-7233	Festive Green	2.78	2.50
A00769-7273	Forest Green	2.78	2.50
A00769-2223	Grey Sky	2.78	2.50
A00769-7013	Hauser Medium Green	2.78	2.50
A00769-8003	Honey Brown	2.78	2.50
A00769-5133	Indian Turquoise	2.78	2.50
A00769-4913	Jack-o-Lantern Orange	2.78	2.50
A00769-2023	Lamp (Ebony) Black	2.78	2.50
A00769-6043	Lavender	2.78	2.50
A00769-4063	Lemon Yellow	2.78	2.50
A00769-1113	Light Buttermilk	2.78	2.50
A00769-5043	Navy Blue	2.78	2.50
A00769-5213	Ocean Blue	2.78	2.50
A00769-5213	Peacock Teal	2.78	2.50
A00769-1143	Poodle Skirt Pink	2.78	2.50
A00769-5923	Primary Blue Trans	2.78	2.50
A00769-3743	Primary Red	2.78	2.50
A00769-6003	Purple Cow	2.78	2.50
A00769-5633	Purple Pizzazz	2.78	2.50
A00769-8073	Raw Umber	2.78	2.50
A00769-3753	Royal Fuchsia	2.78	2.50
A00769-3703	Santa Red	2.78	2.50
A00769-5163	Sea Breeze	2.78	2.50
A00769-2623	Slate Grey	2.78	2.50
A00769-1183	Snow (Titanium) White	2.78	2.50
A00769-7953	Sour Apple	2.78	2.50
A00769-7563	Sweet Mint	2.78	2.50
A00769-5283	True Blue	2.78	2.50
A00769-3713	True Red	2.78	2.50
A00769-3723	Tuscan Red	2.78	2.50
A00769-5343	Ultra Blue Deep Trans	2.78	2.50
A00769-5233	Ultra Blue Trans	2.78	2.50
A00769-6063	Vivid Violet	2.78	2.50
A00769-8143	Warm Beige	2.78	2.50
A00769-1083	Warm White	2.78	2.50
A00769-1793	White Wash	2.78	2.50

DecoArt Pouring Medium

This waterbased medium thins acrylic paint to the ideal consistency for pouring, without sacrificing adhesive properties or slowing the drying time. Its flexible film won't crack or craze, and it's non-yellowing.

NUMBER	SIZE	EACH
A00791-1005	8 oz (236.5 ml)	\$6.85
A00791-1006	16 oz (473 ml)	11.43
A00791-1008	64 oz (1.89 Liter)	40.08

DecoArt Top Coat Medium

Ideal for canvases, wood panels, and other flat art surfaces, this topcoat flows into a thick, self-leveling, crystal-clear coating. It dries into a hard and glossy lacquer-like finish that won't yellow over time.

NUMBER	SIZE	EACH
A00792-1005	8 oz (236.5 ml)	\$9.38
A00792-1006	16 oz (473 ml)	17.82
A00792-1008	64 oz (1.89 Liter)	60.55



Chromacryl Acrylic Essentials

Developed for the middle school teacher, this economical paint offers good solubility, intense color, and rich consistency for painting, printing, and sculpture. **Colors can be assorted for quantity pricing.**

COLOR	16 OZ (473 ML)	HALF GALLON (1.89 LITER)
Black	A00673-2026	A00673-2028
Block Out White	A00673-1006	A00673-1008
Burnt Umber	A00673-8006	A00673-8008
Burnt Sienna	A00673-8046	A00673-8048
Cobalt Blue	A00673-5186	A00673-5188
Cool Blue	A00673-5626	A00673-5628
Cool Red	A00673-3716	A00673-3718
Cool Yellow	A00673-4476	A00673-4478
Green	A00673-7016	A00673-7018
Green Deep	A00673-3076	A00673-3078
Magenta	A00673-3046	A00673-3048
Orange	A00673-4516	A00673-4518
Purple	A00673-6006	A00673-6008
Raw Sienna	A00673-8066	A00673-8068
Raw Umber	A00673-8076	A00673-8078
Red Oxide	A00673-3126	A00673-3128
Warm Blue	A00673-5506	A00673-5508
Warm Red	A00673-3776	A00673-3778
Warm Yellow	A00673-4426	A00673-4428
White	A00673-1026	A00673-1028



Chromacryl Acrylic Essentials Sets

Choose from versatile sets ideal for a variety of projects.

Set of 6 Primary Colors — Black, Cool Blue, Cool Yellow, Green, Warm Red, and White.

NUMBER	SIZE	EACH	12/EA
A00673-2069	Pint (473 ml) Bottles	\$42.15	\$37.95
A00673-0069	Half Gallon (1.89 Liter) Bottles	122.85	110.62

Set of 6 Secondary Colors — Brown, Cool Red, Orange, Purple, Warm Blue, and Warm Yellow.

NUMBER	SIZE	EACH	12/EA
A00673-3069	Pint (473 ml) Bottles	\$42.15	\$37.95
A00673-1069	Half Gallon (1.89 Liter) Bottles	122.85	110.62

Set of 12 — Black, Brown, Cool Blue, Cool Red, Cool Yellow, Green, Orange, Purple, Warm Blue, Warm Red, Warm Yellow, and White.

NUMBER	DESCRIPTION	EACH	12/EA
A00673-2129	6.8 oz (200 ml) Tubes	\$44.85	\$40.37
A00673-0129	Pint (473 ml) Bottles	85.15	76.65

Starter Pack of 96 Tubes — Contains 12, 0.68 oz (20 ml) tubes each of Black, Cool Blue, Cool Red, Cool Yellow, White, Warm Blue, Warm Red, and Warm Yellow.

NUMBER	EACH	12/EA
A00673-2969	\$103.15	\$92.85

CHROMACRYL



Set of 6 Primary Pints — Includes 16 oz (473 ml) bottles of Cool Blue, Cool Red, Cool Yellow, White, Black, and Green Deep.

NUMBER	EACH	12/EA
A00709-0069	\$65.15	\$58.99

Set of 6 Bright Pints — Includes 16 oz (473 ml) bottles of Violet, Orange Vermilion, Cobalt Blue, White, Magenta, and Green Light.

NUMBER	EACH	12/EA
A00709-1069	\$65.15	\$58.99

Set of 5 Tubes — Includes Cool Red, Cool Yellow, Cool Blue, White, and Black in 2.5 oz (74 ml) tubes.

NUMBER	EACH	12/EA
A00709-1009	\$20.30	\$18.28



Chromacryl Starter Pack

Contains 96, 0.65 oz (20 ml) tubes, including 12 tubes each of Cool Blue, Warm Blue, White, Black, Cool Red, Warm Red, Warm Yellow, and Cool Yellow.

NUMBER	EACH
A00709-0969	\$139.60

Chromacryl Pump Lid for Half Gallon Bottle

Use pump lids in the large Half Gallon (1.92 L) bottles. Pump lids mean no more spills or messy containers.

NUMBER	EACH	12/EA
A00709-0080	\$3.25	\$2.93

COLOR	2.5 OZ (75 ML) TUBES	16 OZ (473 ML) BOTTLES	HALF GALLON (1.89 LITER)
Black	A00709-2004	A00709-2006	A00709-2008
Block Out White	—	A00709-1026	A00709-1028
Burnt Sienna	A00709-8044	A00709-8046	A00709-8048
Burnt Umber	A00709-8054	A00709-8056	A00709-8058
Cobalt Blue	A00709-5184	A00709-5186	A00709-5188
Cool Blue	A00709-5624	A00709-5626	A00709-5628
Cool Red	A00709-3714	A00709-3716	A00709-3718
Cool Yellow	A00709-4474	A00709-4476	A00709-4478
Gold	A00709-9004	A00709-9006	A00709-9008
Green Deep	A00709-7044	A00709-7046	A00709-7048
Green Light	A00709-7014	A00709-7016	A00709-7018
Magenta	A00709-3044	A00709-3046	A00709-3048
Neon Blue	A00709-5124	A00709-5126	A0

BLICK® studio acrylics

- 60 bright, intense colors
- Great for teaching color theory
- Heavy bodied

Blick® Studio Acrylics

A combination of price and performance makes Blick Studio Acrylic Colors a great value for students and beginning artists. The colors mix well, so they're ideal for teaching color theory. A high pigment concentration assures strong color power and coverage, and the acrylics have a buttery texture similar to oil paint that holds impasto brush and knife marks. They dry to a permanent, non-yellowing, lightfast paint film that's non-resoluble and flexible. **Colors can be assorted for quantity pricing.**



Color swatches are full strength and 50% tint.

COLOR	4 OZ (120 ML)	8 OZ (250 ML)
Alizarin Crimson	A01637-3060	A01637-3062
Bright Aqua Green	A01637-7110	A01637-7112
Brilliant Purple	A01637-6070	—
Brilliant Yellow Green	A01637-4750	—
Bronze	A01637-8150	—
Burnt Sienna	A01637-8040	A01637-8042
Burnt Umber	A01637-8050	A01637-8052
Cadmium Orange Hue	A01637-4540	A01637-4542
Cadmium Red Deep Hue	A01637-3710	A01637-3712
Cadmium Red Light Hue	A01637-3180	A01637-3182
Cadmium Red Med Hue	A01637-3230	A01637-3232
Cadmium Ylw Dp Hue	A01637-4280	A01637-4282
Cadmium Ylw Lt Hue	A01637-4130	A01637-4132
Cadmium Ylw Med Hue	A01637-4190	A01637-4192
Cerulean Blue Hue	A01637-5170	A01637-5172
Cobalt Blue Hue	A01637-5190	A01637-5192
Copper	A01637-8122	—
Deep Violet	A01637-6610	—
Dioxazine Purple	A01637-6020	A01637-6022
Fluorescent Blue	A01637-5240	—
Fluorescent Green	A01637-7270	—
Fluorescent Orange	A01637-4560	—
Fluorescent Pink	A01637-3720	—
Fluorescent Purple	A01637-6420	—
Fluorescent Yellow	A01637-4220	—
Gold	A01637-9010	—
Green Deep Permanent	A01637-7080	—
Green Light Permanent	A01637-7090	A01637-7092
Hooker's Green	A01637-7120	A01637-7122
Ivory Black	A01637-2250	A01637-2252

COLOR	4 OZ (120 ML)	8 OZ (250 ML)
Light Blue Permanent	A01637-5430	—
Light Blue Violet	A01637-5390	—
Mars Black	A01637-2040	A01637-2042
Mars Black Gloss	A01637-2050	—
Medium Magenta	A01637-3310	—
Metallic Magenta	A01637-3040	—
Metallic Pearl	A01637-1090	—
Metallic Purple	A01637-6410	—
Metallic Teal	A01637-5080	—
Naples Yellow	A01637-4140	—
Neutral Gray	A01637-2540	—
Payne's Gray	A01637-2560	—
Phthalo Blue	A01637-5160	A01637-5162
Phthalo Green	A01637-7800	A01637-7802
Primary Blue	A01637-5920	—
Primary Red	A01637-3740	—
Primary Yellow	A01637-4530	A01637-4532
Prism Violet	A01637-6540	—
Quinacridone Magenta	A01637-3620	A01637-3622
Raw Sienna	A01637-8060	A01637-8062
Raw Umber	A01637-8070	—
Red Oxide	A01637-3120	—
Rosy Beige	A01637-3300	—
Sap Green	A01637-7190	—
Silver	A01637-9330	—
Titanium Buff	A01637-8620	—
Titanium White	A01637-1020	A01637-1022
Titanium White Gloss	A01637-1030	—
Ultramarine Blue	A01637-5230	A01637-5232
Yellow Oxide	A01637-4110	—

COLOR	NUMBER
Bright Aqua Green	A01637-7115
Burnt Umber	A01637-8055
Cad Red Medium Hue	A01637-3235
Cad Yellow Deep Hue	A01637-4285
Cerulean Blue Hue	A01637-5175
Dioxazine Purple	A01637-6025
Green Light Permanent	A01637-7435
Ivory Black	A01637-2255
Mars Black	A01637-2045
Primary Blue	A01637-5925
Primary Red	A01637-3745
Primary Yellow	A01637-4535
Titanium White	A01637-1025
Ultramarine Blue	A01637-5235

EACH 24/EA
\$17.06 \$15.35

PRODUCT REVIEWS
are a great way to share
your opinions with others as
well as find the products
that best meet your needs!



To learn more, visit
DickBlick.com/productinfo/reviews



Blick® Studio Acrylic Sets

Set of 12 — Includes one 0.7 oz (21 ml) tube each of Alizarin Crimson, Burnt Sienna, Burnt Umber, Cadmium Orange Hue, Dioxazine Purple, Green Light Permanent, Ivory Black, Phthalo Green, Primary Blue, Primary Red, Primary Yellow, and Titanium White.

NUMBER A01637-0129 EACH \$22.99 12/EA \$20.55



Set of 24 — Includes the colors in the Set of 12 plus one each of Cadmium Red Light Hue, Cadmium Yellow Medium Hue, Cerulean Blue Hue, Cobalt Blue Hue, Hooker's Green, Phthalo Blue, Quinacridone Magenta, Raw Sienna, Raw Umber, Red Oxide, Ultramarine Blue, and Yellow Oxide in 21 ml (0.7 oz) tubes.

NUMBER A01637-0249 EACH \$33.79 12/EA \$30.41



Set of 36 — Includes the colors in the Set of 24 plus one each of Bright Aqua Green, Cadmium Red Deep Hue, Cadmium Red Medium Hue, Cadmium Yellow Deep Hue, Cadmium Yellow Light Hue, Deep Violet, Gold, Green Deep Permanent, Mars Black, Medium Magenta, Neutral Gray, and Silver in 0.7 (21 ml) tubes.

NUMBER A01637-0369 EACH \$42.98 12/EA \$38.68



Set of 48 — Includes the colors in the Set of 36 plus one each of Brilliant Purple, Brilliant Yellow Green, Bronze, Copper, Light Blue Permanent, Light Blue Violet, Naples Yellow, Payne's Gray, Prism Violet, Rosy Beige, Sap Green, and Titanium Buff in 0.7 (21 ml) tubes.

NUMBER A01637-0489 EACH \$56.94 12/EA \$51.25

Liquitex Basics® These non-toxic acrylics have permanent adhesive properties and can be used for a variety of techniques from watercolor, airbrushing, and printmaking to thick applications that simulate oil paint. For more sizes and sets, visit DickBlick.com. Colors can be assorted for quantity pricing.

Table with columns for COLOR, 4 oz (118 ml) Tubes, 8.5 oz (250 ml), 13.5 oz (400 ml), 32 oz (946 ml), and pricing (EACH, 12/EA).



Liquitex Basics Acrylic Mediums Mix Basics Mediums with acrylic paint to adjust how the paint works, feels, and looks. Use permanent Basics Varnishes to protect finished paintings. For details, visit DickBlick.com.



Starter Set of 5 — Explore Basics Mediums with this sample set.



Liquitex Basics Acrylic Gesso Formulated to produce a smooth, absorbent, finely textured ground for painting on most porous surfaces.

LIQUITEX®



Liquitex Basics Sets table with columns for NUMBER, DESCRIPTION, EACH, and 12/EA.

Utrecht studio series acrylics



Utrecht Studio Series Acrylics are loaded with vibrant, concentrated color and provide great coverage. Their medium viscosity formulation makes them an economical choice for educators and students.

Utrecht Studio Series Acrylics table with columns for COLOR, 8 oz (237 ml) TUBES, PINT (473 ml) JARS, QUART (946 ml) JARS, and pricing (EACH, 6/EA).

Chroma[®] A2 Lightfast Heavy Body Acrylics

Serious paint that looks, feels, and handles like professional acrylic. Dries to a low-gloss finish. Colors can be assorted for quantity pricing.

4 oz (120 ml) Tubes					
NUMBER	COLOR	EACH	6/EA		
A00656-3064	Alizarine Crimson	\$5.11	\$4.61		
A00656-3044	Brilliant Mngta	5.11	4.61		
A00656-6554	Brilliant Violet	5.11	4.61		
A00656-8044	Burnt Sienna	5.11	4.61		
A00656-8054	Burnt Umber	5.11	4.61		
A00656-4544	Cadmium Orange Hue	5.11	4.61		
A00656-3234	Cadmium Red Med Hue	5.11	4.61		
A00656-3564	Cadmium Scarlet Hue	5.11	4.61		
A00656-4284	Cadmium Ylw Dp Hue	5.11	4.61		
A00656-4134	Cadmium Ylw Lt Hue	5.11	4.61		
A00656-4194	Cadmium Ylw Med Hue	5.11	4.61		
A00656-5174	Cerulean Blue Hue	5.11	4.61		
A00656-5194	Cobalt Blue Hue	5.11	4.61		
A00656-5374	Cobalt Turquoise Light	5.11	4.61		
A00656-9504	Copper	5.11	4.61		
A00656-6024	Dioxazine Purple	5.11	4.61		
A00656-3844	Flesh Tint	5.11	4.61		
A00656-8914	Gold	5.11	4.61		
A00656-7014	Green Light	5.11	4.61		
A00656-7274	Green Oxide	5.11	4.61		
A00656-7914	Hooker's Green	5.11	4.61		
A00656-3264	Indian Red Oxide	5.11	4.61		
A00656-4164	Indian Yellow	5.11	4.61		
A00656-2254	Ivory Black	5.11	4.61		
A00656-2044	Mars Black	5.11	4.61		
A00656-7074	Olive Green	5.11	4.61		
A00656-2554	Payne's Gray	5.11	4.61		
A00656-7084	Perm Green Deep	5.11	4.61		
A00656-7394	Perm Sap Green	5.11	4.61		
A00656-5164	Phthalo Blue	5.11	4.61		
A00656-7804	Phthalo Green	5.11	4.61		
A00656-3784	Quina Red Violet Hue	5.11	4.61		
A00656-8064	Raw Sienna	5.11	4.61		
A00656-8074	Raw Umber	5.11	4.61		
A00656-3724	Red Gold	5.11	4.61		
A00656-9334	Silver	5.11	4.61		
A00656-1024	Titanium White	5.11	4.61		
A00656-5234	Ultramarine Blue	5.11	4.61		
A00656-1744	Unbleached Titanium	5.11	4.61		
A00656-4114	Yellow Oxide	5.11	4.61		

8.45 oz (250 ml) Jars					
NUMBER	COLOR	EACH	6/EA		
A00656-2045	Mars Black	\$7.37	\$6.63		
A00656-8065	Raw Sienna	7.37	6.63		
A00656-1025	Titanium White	7.37	6.63		
A00656-1745	Unbleached Titanium	7.37	6.63		

Chroma[®] A2 Lightfast Heavy Body Acrylic Sets

Set of 4 — Contains Titanium White, Cadmium Yellow Medium Hue, Cadmium Scarlet Hue, and Ultramarine Blue in 4 oz (120 ml) tubes.

NUMBER	EACH	6/EA
A00656-1049	\$17.77	\$15.99

Set of 6 — Contains Cadmium Scarlet Hue, Cadmium Yellow Medium Hue, Mars Black, Phthalo Green Hue, Titanium White, and Ultramarine Blue in 8.45 oz (250 ml) jars.

NUMBER	EACH	6/EA
A00656-0069	\$44.94	\$40.45

Set of 8 — Contains Titanium White, Cadmium Yellow Light Hue, Cadmium Orange Hue, Cadmium Red Medium Hue, Alizarine Crimson Hue, Dioxazine Purple, Phthalo Blue, and Phthalo Green in 4 oz (120 ml) tubes.

NUMBER	EACH	6/EA
A00656-1089	\$35.36	\$31.83

AMSTERDAM[®]

Amsterdam[®] Standard Series Acrylics

An excellent choice for the beginning or intermediate artist. All colors have the maximum ASTM 1 rating for lightfastness. Sets available online at DickBlick.com. Colors can be assorted for quantity pricing.

4 oz (120 ml) Tubes					
NUMBER	COLOR	EACH	12/EA		
A00643-4913	Azo Orange	\$5.94	\$5.34		
A00643-4923	Azo Yellow Deep	5.94	5.34		
A00643-4063	Azo Yellow Lemon	5.94	5.34		
A00643-4933	Azo Yellow Light	5.94	5.34		
A00643-4603	Azo Yellow Med	5.94	5.34		
A00643-5063	Brilliant Blue	5.94	5.34		
A00643-7473	Brilliant Green	5.94	5.34		
A00643-8043	Burnt Sienna	5.94	5.34		
A00643-8053	Burnt Umber	5.94	5.34		
A00643-6653	Caput Mortum Violet	5.94	5.34		
A00643-3153	Carmine	5.94	5.34		
A00643-5183	Cobalt Blue Ultra	5.94	5.34		
A00643-7053	Emerald Green	5.94	5.34		
A00643-9043	Gold Ochre	5.94	5.34		
A00643-4073	Gold Yellow	5.94	5.34		
A00643-2613	Graphite	7.55	6.79		
A00643-2603	Greyish Blue	5.94	5.34		
A00643-7763	Greenish Blue	5.94	5.34		
A00643-7903	Greenish Yellow	5.94	5.34		
A00643-5813	Kings Blue	5.94	5.34		
A00643-2013	Lamp Black	5.94	5.34		
A00643-3503	Light Rose	5.94	5.34		
A00643-5933	Manganese Blue Phthalo	5.94	5.34		
A00643-9603	Metallic Bronze	7.55	6.79		
A00643-9513	Metallic Copper	7.55	6.79		
A00643-9123	Metallic Deep Gold	7.55	6.79		
A00643-9113	Metallic Light Gold	7.55	6.79		
A00643-2213	Metallic Pewter	7.55	6.79		
A00643-9303	Metallic Silver	7.55	6.79		
A00643-3613	Naphthol Red Deep	5.94	5.34		
A00643-3193	Naphthol Red Light	5.94	5.34		
A00643-3733	Naphthol Red Medium	5.94	5.34		
A00643-4523	Naples Yellow Deep	5.94	5.34		
A00643-7933	Naples Yellow Green	5.94	5.34		
A00643-4793	Naples Yellow Light	5.94	5.34		
A00643-4143	Naples Yellow Red	5.94	5.34		
A00643-4783	Naples Yellow Red Light	5.94	5.34		
A00643-2543	Neutral Grey	5.94	5.34		
A00643-4903	Nickel Titanium Yellow	5.94	5.34		
A00643-7083	Olive Green Deep	5.94	5.34		
A00643-7073	Olive Green Light	5.94	5.34		
A00643-2023	Oxide Black	5.94	5.34		
A00643-2563	Paynes Grey	5.94	5.34		
A00643-5443	Pearl Blue	7.55	6.79		
A00643-7543	Pearl Green	7.55	6.79		

Grumbacher[®] Academy Acrylics

Unlike many of the so-called "budget" brands, Grumbacher uses genuine pigments, such as pure cadmiums, to produce Academy Acrylics. All colors have the maximum ASTM 1 rating for lightfastness. Colors can be assorted for quantity pricing.

2.5 oz (75 ml) Tubes					
NUMBER	COLOR	EACH	12/EA		
A00605-3060	Alizarine Crimson	\$5.63	\$5.05		
A00605-8040	Burnt Sienna	5.63	5.05		
A00605-8050	Burnt Umber	5.63	5.05		
A00605-4540	Cadmium Orange Hue	5.63	5.05		
A00605-3540	Cadmium Red Lt Hue	5.63	5.05		
A00605-3320	Cadmium Red Hue Dp	5.63	5.05		
A00605-3230	Cadmium Red Med Hue	5.63	5.05		
A00605-4280	Cadmium Ylw Dp Hue	5.63	5.05		
A00605-4060	Cadmium Ylw Lt Hue	5.63	5.05		
A00605-4080	Cadmium Ylw Med Hue	5.63	5.05		
A00605-5170	Cerulean Blue Hue	5.63	5.05		
A00605-5190	Cobalt Blue Hue	5.63	5.05		
A00605-6610	Deep Violet	5.63	5.05		
A00605-6020	Dioxazine Purple	5.63	5.05		
A00605-3710	Grumbacher Red	5.63	5.05		
A00605-7910	Hooker's Green Hue	5.63	5.05		
A00605-1060	Iridescent White	5.63	5.05		

4 oz (120 ml) Tubes					
NUMBER	COLOR	EACH	12/EA		
A00643-3743	Pearl Red	\$7.55	\$6.79		
A00643-6413	Pearl Violet	7.55	6.79		
A00643-1093	Pearl White	7.55	6.79		
A00643-4853	Pearl Yellow	7.55	6.79		
A00643-3823	Perm Red Violet Lt	5.94	5.34		
A00643-5913	Permanent Blue Violet	5.94	5.34		
A00643-7043	Permanent Green Deep	5.94	5.34		
A00643-7553	Permanent Green Light	5.94	5.34		
A00643-3813	Permanent Red Purple	5.94	5.34		
A00643-3803	Permanent Red Violet	5.94	5.34		
A00643-3413	Persian Rose	5.94	5.34		
A00643-5163	Phthalo Blue	5.94	5.34		
A00643-7803	Phthalo Green	5.94	5.34		
A00643-5953	Primary Cyan	5.94	5.34		
A00643-3043	Primary Magenta	5.94	5.34		
A00643-4533	Primary Yellow	5.94	5.34		
A00643-5223	Prussian Blue	5.94	5.34		
A00643-3763	Pyrrrole Red	5.94	5.34		
A00643-3793	Quinacridone Rose	5.94	5.34		
A00643-3783	Quinacridone Rose Light	5.94	5.34		
A00643-8033	Raw Sienna	5.94	5.34		
A00643-8073	Raw Umber	5.94	5.34		
A00643-7843	Reflex Green	7.55	6.79		
A00643-4963	Reflex Orange	7.55	6.79		
A00643-3953	Reflex Rose	7.55	6.79		
A00643-4953	Reflex Yellow	7.55	6.79		
A00643-7093	Sap Green	5.94	5.34		
A00643-5073	Sky Blue Light	5.94	5.34		
A00643-8633	Titanium Buff Deep	5.94	5.34		
A00643-8623	Titanium Buff Light	5.94	5.34		
A00643-1023	Titanium White	5.94	5.34		
A00643-3723	Transparent Red Med	5.94	5.34		
A00643-4553	Transparent Yellow Med	5.94	5.34		
A00643-5113	Turquoise Blue	5.94	5.34		
A00643-7913	Turquoise Green	5.94	5.34		
A00643-5233	Ultramarine	5.94	5.34		
A00643-6743	Ultramarine Violet	5.94	5.34		
A00643-6723	Ultramarine Violet Light	5.94	5.34		
A00643-8313	VanDyke Brown	5.94	5.34		
A00643-3753	Venetian Rose	5.94	5.34		
A00643-3283	Vermilion	5.94	5.34		
A00643-2323	Warm Grey	5.94	5.34		
A00643-4043	Yellow Ochre	5.94	5.34		
A00643-4753	Yellowish Green	5.94	5.34		
A00643-1033	Zinc White	5.94	5.34		

2.5 oz (75 ml) Tubes					
NUMBER	COLOR	EACH	12/EA		
A00605-2250	Ivory Black	\$5.63	\$5.05		
A00605-2020	Lamp Black	5.63	5.05		
A00605-4160	Lemon Yellow	5.63	5.05		
A00605-2030	Mars Black	5.63	5.05		
A00605-1300	Mixing White	5.63	5.05		
A00605-4140	Naples Yellow	5.63	5.05		
A00605-2540	Neutral Gray	5.63	5.05		
A00605-3360	Pale Pink	5.63	5.05		
A00605-2560	Payne's Gray	5.63	5.05		
A00605-5430	Permanent Blue Light	5.63	5.05		
A00605-7310	Permanent Green Light	5.63	5.05		
A00605-5510	Process Cyan	5.63	5.05		
A00605-3720	Process Magenta	5.63	5.05		
A00605-4400	Process Yellow	5.63	5.05		
A00605-5220	Prussian Blue	5.63	5.05		
A00605-8060	Raw Sienna	5.63	5.05		
A00605-8070	Raw Umber	5.63	5.05		
A00605-7090	Sap Green	5.63	5.05		
A00605-9010	Thalo Gold	5.63	5.05		
A00605-9330	Thalo Silver	5.63	5.05		
A00605-5140	Thalo Blue	5.63	5.05		
A00605-7190	Thalo Grn Blue Shade	5.63	5.05		
A00605-4750	Thalo Yellow Green	5.63	5.05		
A00605-6550	Thio Violet	5.63	5.05		
A00605-1010	Titanium White	5.63	5.05		
A00605-7900	Turquoise Green	5.63	5.05		
A00605-5230	Ultramarine Blue	5.63	5.05		
A00605-1020	Unbleached Titan White	5.63	5.05		
A00605-3280	Vermilion	5.63	5.05		
A00605-2320	Warm Gray	5.63	5.05		
A00605-4830	Yellow Ochre Light	5.63	5.05		



For Amsterdam Standard Series Acrylic sets, visit DickBlick.com.



Sennelier[®] Abstract[®] Acrylics

Take your painting beyond the norm with revolutionary Sennelier Abstract Acrylics. These highly pigmented, heavy body acrylics come in a unique pouch that's not only economical but doubles as a painting tool. Great for urban art, large murals, or abstract expressionism. Colors can be assorted for quantity pricing.

4 oz (120 ml) Pouches					
NUMBER	COLOR	EACH	12/EA		
A00760-5910	Azure Blue	\$8.32	\$7.49		
A00760-3160	Blush Tint	8.32	7.49		
A00760-7340	Bright Yellow Green	8.32	7.49		
A00760-7210	Burnt Earth Green	8.32	7.49		
A00760-8710	Burnt Sienna	8.			

BLICK® artists' acrylics

Smooth, lightfast, and permanent, with excellent pigment quality, color strength, and longevity, Blick Artists' Acrylics offer an exceptional combination of quality and value. Colors may be assorted for quantity pricing.



Blick® Artists' Acrylic Portrait Color Set

This set contains six 2 oz (59 ml) colors for portrait painting, including Light Pink, Cadmium Red Light Hue, Burnt Sienna, Burnt Umber, Raw Umber, and Yellow Oxide.

NUMBER EACH
A00624-1039 \$38.50



Blick® Artists' Acrylic Basic Set

This popular set contains six 2 oz (59 ml) tubes, including Yellow Medium Azo, Naphthol Crimson, Ultramarine Blue, Mars Black, Phthalocyanine Green, and Titanium White.

NUMBER EACH
A00624-1029 \$37.38



Blick® Artists' Acrylic Earth Color Set

Six 2 oz (59 ml) tubes, perfect for a landscape palette: Burnt Umber, Burnt Sienna, Raw Sienna, Yellow Oxide, Cadmium Orange, and Cadmium Red Light.

NUMBER EACH
A00624-2009 \$38.80

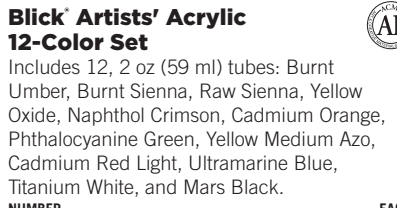

Blick® Artists' Acrylic 12-Color Set

Includes 12, 2 oz (59 ml) tubes: Burnt Umber, Burnt Sienna, Raw Sienna, Yellow Oxide, Naphthol Crimson, Cadmium Orange, Phthalocyanine Green, Yellow Medium Azo, Yellow Ochre, Ultramarine Blue, Titanium White, and Mars Black.

NUMBER EACH
A00624-1009 \$60.36

COLOR	4.65 OZ (138 ML)	EACH	6/EA	8 OZ (237 ML)	EACH	6/EA	16 OZ (473 ML)	EACH	6/EA
Alizarin Crimson Hue	A00624-3444	\$13.26	\$11.93	A00624-3445	\$15.24	\$13.68	A00624-3446	\$25.85	\$23.27
Brilliant Blue	A00624-5064	10.61	9.55	A00624-5065	11.63	10.47	A00624-5066	19.07	17.15
Buff White	A00624-1174	10.61	9.55						
Burnt Sienna	A00624-8044	10.61	9.55	A00624-8045	11.63	10.47	A00624-8046	19.07	17.15
Burnt Umber	A00624-8054	10.61	9.55	A00624-8055	11.63	10.47	A00624-8056	19.07	17.15
Cadmium Orange	A00624-4534	13.91	12.52	A00624-4535	17.14	15.43	A00624-4536	32.78	29.51
Cadmium Orange Hue	A00624-4544	13.26	11.93						
Cadmium Red Light	A00624-3094	18.44	16.59	A00624-3095	25.85	23.27	A00624-3096	41.21	37.08
Cadmium Red Lt Hue	A00624-3184	13.91	12.52	A00624-3185	17.14	15.43	A00624-3186	32.78	29.51
Cadmium Red Med Hue	A00624-3234	13.26	11.93	A00624-3235	15.24	13.68	A00624-3236	25.85	23.27
Cadmium Red Medium	A00624-3104	18.44	16.59	A00624-3105	25.85	23.27	A00624-3106	41.21	37.08
Cadmium Yellow Deep	A00624-4124	18.44	16.59						
Cadmium Yw Dp Hue	A00624-4284	13.91	12.52						
Cadmium Yellow Light	A00624-4074	13.91	12.52	A00624-4075	17.14	15.43	A00624-4076	32.78	29.51
Cadmium Yw Lt Hue	A00624-4134	13.26	11.93	A00624-4135	15.24	13.68	A00624-4136	25.85	23.27
Cadmium Yellow Med	A00624-4094	13.91	12.52	A00624-4095	17.14	15.43	A00624-4096	32.78	29.51
Cadmium Yw Med Hue	A00624-4194	10.61	9.55	A00624-4195	11.63	10.47	A00624-4196	19.07	17.15
Cerulean Blue	A00624-5164	18.44	16.59	A00624-5165	25.85	23.27	A00624-5166	41.21	37.08
Chromium Oxide Green	A00624-7114	13.26	11.93	A00624-7115	15.24	13.68	A00624-7116	25.85	23.27
Cobalt Blue	A00624-5184	18.44	16.59	A00624-5185	25.85	23.27	A00624-5186	41.21	37.08
Cobalt Blue Hue	A00624-5194	13.26	11.93						
Cobalt Teal	A00624-5094	18.44	16.59						
Cyan	A00624-5594	10.61	9.55						
Dioxazine Purple	A00624-6024	13.26	11.93	A00624-6025	15.24	13.68	A00624-6026	25.85	23.27
Emerald Green	A00624-7054	10.61	9.55	A00624-7055	11.63	10.47	A00624-7056	19.07	17.15
Green Gold	A00624-9174	13.91	12.52						
Hooker's Green	A00624-7124	10.61	9.55	A00624-7125	11.63	10.47	A00624-7126	19.07	17.15
Indo Orange Red	A00624-4574	13.26	11.93	A00624-4575	15.24	13.68	A00624-4576	25.85	23.27
Iridescent Antique Gold	A00624-9024	13.91	12.52						
Iridescent Bronze	A00624-9614	13.91	12.52						
Iridescent Copper	A00624-9534	13.91	12.52						
Iridescent Gold	A00624-9014	13.26	11.93	A00624-9015	15.24	13.68	A00624-9016	25.85	23.27
Iridescent Rich Gold	A00624-9264	13.91	12.52						
Iridescent Silver	A00624-9314	13.26	11.93	A00624-9315	15.24	13.68	A00624-9316	25.85	23.27
Iridescent White	A00624-1064	13.26	11.93	A00624-1065	15.24	13.68	A00624-1066	25.85	23.27
Ivory Black	A00624-2254	10.61	9.55	A00624-2255	11.63	10.47	A00624-2256	19.07	17.15
Light Pink	A00624-3304	10.61	9.55	A00624-3305	11.63	10.47	A00624-3306	19.07	17.15
Mars Black	A00624-2044	10.61	9.55	A00624-2045	11.63	10.47	A00624-2046	19.07	17.15
Medium Gray	A00624-2524	10.61	9.55						
Medium Magenta	A00624-3314	10.61	9.55	A00624-3315	11.63	10.47	A00624-3316	19.07	17.15
Medium Violet	A00624-6544	13.26	11.93						
Metal Silver	A00624-9304	18.44	16.59						
Naphthol Crimson	A00624-3224	13.26	11.93	A00624-3225	15.24	13.68	A00624-3226	25.85	23.27
Naphthol Red Light	A00624-3194	13.91	12.52	A00624-3195	17.14	15.43	A00624-3196	32.78	29.51
Payne's Gray	A00624-2564	10.61	9.55	A00624-2565	11.63	10.47	A00624-2566	19.07	17.15
Perm Green Light	A00624-7084	13.91	12.52	A00624-7085	17.14	15.43	A00624-7086	32.78	29.51
Perm Hkr Green Hue	A00624-7324	10.61	9.55	A00624-7325	11.63	10.47	A00624-7326	19.07	17.15
Phthalo Blue GS	A00624-5754	10.61	9.55						
Phthalo Green YS	A00624-7564	10.61	9.55						
Phthalocyanine Blue	A00624-5144	10.61	9.55	A00624-5145	11.63	10.47	A00624-5146	19.07	17.15
Phthalocyanine Green	A00624-7064	10.61	9.55	A00624-7065	11.63	10.47	A00624-7066	19.07	17.15
Pyrrrole Red	A00624-3764	18.44	16.59						
Quinacridone Dark Red	A00624-3294	18.44	16.59						
Quinacridone Magenta	A00624-3624	18.44	16.59						
Quinacridone Red	A00624-3274	13.91	12.52	A00624-3275	17.14	15.43	A00624-3276	32.78	29.51
Quinacridone Violet	A00624-6514	13.91	12.52	A00624-6515	17.14	15.43	A00624-6516	32.78	29.51
Raw Sienna	A00624-8064	10.61	9.55	A00624-8065	11.63	10.47	A00624-8066	19.07	17.15
Raw Umber	A00624-8074	10.61	9.55	A00624-8075	11.63	10.47	A00624-8076	19.07	17.15
Red Oxide	A00624-3124	10.61	9.55	A00624-3125	11.63	10.47	A00624-3126	19.07	17.15
Sap Green	A00624-7094	13.26	11.93						
Titanium White	A00624-1014	10.61	9.55	A00624-1015	11.63	10.47	A00624-1016	19.07	17.15
Turquoise Green	A00624-5264	10.61	9.55	A00624-5265	11.63	10.47	A00624-5266	19.07	17.15
Ultramarine Blue	A00624-5234	10.61	9.55	A00624-5235	11.63	10.47	A00624-5236	19.07	17.15
Ultramarine Violet	A00624-6734	18.44	16.59						
Yellow Green	A00624-4754	13.26	11.93						
Yellow Light Hansa	A00624-4224	10.61	9.55	A00624-4225	11.63	10.47	A00624-4226	19.07	17.15
Yellow Medium Azo	A00624-4234	10.61	9.55	A00624-4235	11.63	10.47	A00624-4236	19.07	17.15
Yellow Ochre	A00624-4044	10.61	9.55						
Yellow Oxide	A00624-4114	10.61	9.55	A00624-4115	11.63	10.47	A00624-4116	19.07	17.15
Zinc Oxide	A00624-1094	10.61	9.55						

For 2 oz (59 ml) tubes, visit DickBlick.com.

HEALTH & SAFETY ICONS: ●=CL / ■=Prop 65 / ▼=CL & Prop 65
See page 644 for more information.

BLICK® artists' acrylics

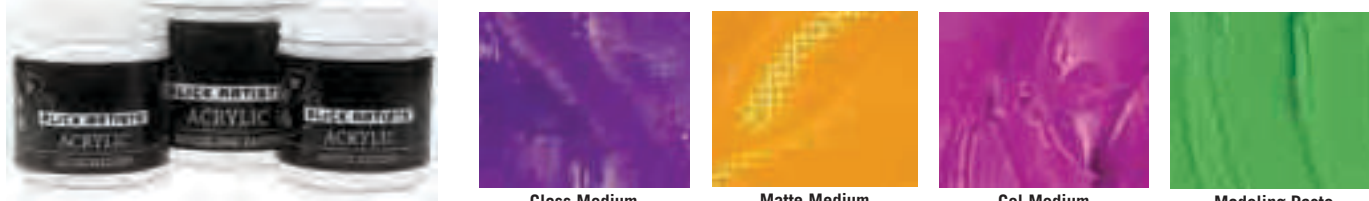

BLICK® artists' acrylic mediums

Gloss Medium — The same high-quality polymer emulsion used as a binder for our acrylic colors. Dries crystal-clear and glossy. Mix it with acrylic paint for a uniform glossy finish or a transparent glaze. May also be used as a varnish.

NUMBER	SIZE	EACH	12/EA	24/EA
A00623-1035	8 oz (236 ml) Jar	\$12.93	\$11.63	\$11.05
A00623-1036	Pint (473 ml)	18.95	17.05	16.20
A00623-1037	Quart (946 ml)	30.16	27.12	25.77
A00623-1039	Gallon (3.78 Liter)	48.15	43.37	41.20

Matte Medium — Adding Matte Medium to your paint will cause it to dry with a dull finish like casein or tempera. (Not to be used as a varnish.)

NUMBER	SIZE	EACH	12/EA	24/EA
A00623-1045	8 oz (236 ml) Jar	\$9.13	\$8.22	\$7.80
A00623-1046	Pint (473 ml)	13.40	12.06	11.44
A00623-1047	Quart (946 ml)	21.33	19.19	18.20

Gel Medium — Gel is milky white in the jar but dries completely transparent. Its consistency is very thick for producing heavy impastos with a brush or knife. Add to acrylic colors.

NUMBER	SIZE	EACH	12/EA	24/EA
A00623-1014	4.65 oz (138 ml) Tube	\$6.94	\$6.25	\$5.93
A00623-1016	Pint (473 ml)	14.41	12.97	12.31
A00623-1017	Quart (946 ml)	22.93	20.64	19.59

Modeling Paste — Creates a textured ground for painting, collage, relief sculpture, and more. Dries opaque white, hard, and stiff.

NUMBER	SIZE	EACH	12/EA	24/EA
A00623-1064	4.65 oz (138 ml) Tube	\$6.45	\$5.81	\$5.51
A00623-1066	Pint (473 ml)	13.40	12.06	11.44
A00623-1067	Quart (946 ml)	21.33	19.19	18.20

Matte Varnish — For a uniform, non-glare, satin finish on completely dry acrylic paintings.

NUMBER	SIZE	EACH	12/EA	24/EA
A00623-1056	Pint (473 ml)	\$13.40	\$12.06	\$11.44
A00623-1057	Quart (946 ml)	21.33	19.19	18.20

Acrylic Retarder — Slows the drying process.

NUMBER	SIZE	EACH	12/EA	24/EA
A00623-1074	4.65 oz (138 ml) Tube	\$9.13	\$8.21	\$7.80
A00623-1075	8 oz (236 ml) Jar	12.93	11.63	11.05

Acrylic Remover — For removing dried acrylic paint from brushes. This product cannot be shipped to the state of California.

NUMBER	SIZE	EACH	12/EA	24/EA
A00623-1006	Pint (473 ml)	\$12.93	\$11.63	\$11.05

WINSOR & NEWTON™

Winsor & Newton™ Professional Acrylics

Unrivaled in brilliance, Winsor & Newton Professional Acrylics are made with highest-quality, maximum-strength pigments to ensure clean, strong color mixes. A revolutionary transparent binder eliminates color shift from wet to dry.

2 oz (60 ml) Tubes

NUMBER	COLOR	EACH
A01630-9133	Antique Gold	\$13.73
A01630-4923	Azo Yellow Deep	9.91
A01630-4903	Azo Yellow Medium	9.91
A01630-4613	Bismuth Yellow	16.77
A01630-8623	Buff Titanium	8.24
A01630-8043	Burnt Sienna	8.24
A01630-8053	Burnt Umber	8.24
A01630-4073	Cadmium Lemon	13.73
A01630-4533	Cadmium Orange	16.77
A01630-3203	Cadmium Red Deep	13.73
A01630-3093	Cadmium Red Light	13.73
A01630-3103	Cadmium Red Medium	13.73
A01630-4123	Cadmium Yellow Deep	13.73
A01630-4133	Cadmium Yellow Light	13.73
A01630-4093	Cadmium Yellow Medium	13.73
A01630-5163	Cerulean Blue	18.12
A01630-5923	Cerulean Blue Chrom	16.77
A01630-5173	Cerulean Blue Hue	9.91
A01630-7653	Chrome Oxide Green	13.73
A01630-5183	Cobalt Blue	16.77
A01630-5193	Cobalt Blue Deep	18.12
A01630-7163	Cobalt Green	16.77
A01630-7663	Cobalt Green Deep	13.73
A01630-5373	Cobalt Turquoise	18.12
A01630-5393	Cobalt Turquoise Light	16.77
A01630-2623	Davy's Gray	8.24
A01630-8023	Dioxazine Purple	13.73
A01630-9013	Gold	13.73
A01630-9033	Gold Ochre	8.24
A01630-2613	Graphite Grey	9.91
A01630-7193	Green Gold	16.77

2 oz (60 ml) Tubes

NUMBER	COLOR	EACH
A01630-7123	Hooker's Green	\$13.73
A01630-5343	Indanthrene Blue	13.73
A01630-1063	Iridescent White	13.73
A01630-2253	Ivory Black	8.24
A01630-4063	Lemon Yellow	9.91
A01630-3013	Light Red	8.24
A01630-2043	Mars Black	8.24
A01630-1303	Mixing White	8.24
A01630-3753	Naphthol Red Light	9.91
A01630-3743	Naphthol Red Medium	9.91
A01630-4143	Naples Yellow	9.91
A01630-4523	Naples Yellow Deep	9.91
A01630-4993	Nickel Azo Yellow	13.73
A01630-7073	Olive Green	9.91
A01630-2563	Payne's Gray	8.24
A01630-3263	Permanent Rose	13.73
A01630-3383	Perm Alizarin Crimson	13.73
A01630-7793	Permanent Sap Green	13.73
A01630-7903	Perylene Green	16.77
A01630-3393	Perylene Maroon	16.77
A01630-3213	Perylene Red	16.77
A01630-6903	Perylene Violet	16.77
A01630-5943	Phthalo Blue GS	9.91
A01630-5913	Phthalo Blue RS	9.91
A01630-7183	Phthalo Green BS	9.91
A01630-7563	Phthalo Green YS	9.91
A01630-5423	Phthalo Turquoise	13.73
A01630-3293	Potter's Pink	13.73
A01630-4583	Pyrrrole Orange	16.77
A01630-3233	Pyrrrole Red	16.77
A01630-3223	Pyrrrole Red Light	16.77
A01630-4593	Quina Burnt Orange	16.77
A01630-9093	Quinacridone Gold	16.77
A01630-3623	Quinacridone Magenta	13.73



2 oz (60 ml) Tubes

NUMBER	COLOR	EACH
A01630-3273	Quinacridone Red	\$13.73
A01630-6513	Quinacridone Violet	13.73
A01630-8063	Raw Sienna	8.24
A01630-8073	Raw Umber	8.24
A01630-8083	Raw Umber Light	8.24
A01630-3773	Red Iron Oxide	8.24
A01630-9113	Renaissance Gold	13.73
A01630-9333	Silver	13.73
A01630-9323	Silver 2	13.73
A01630-1023	Titanium White	8.24
A01630-5233	Ultramarine Blue	9.91
A01630-6733	Ultramarine Violet	9.91
A01630-6723	Violet Iron Oxide	8.24
A01630-4113	Yellow Iron Oxide	8.24
A01630-4043	Yellow Ochre	8.24

Starter Set of 12 — Includes 12, 0.7 oz (20 ml) tubes including Azo Yellow Medium, Lemon Yellow, Mars Black, Naphthol Red Light, Olive Green, Permanent Alizarin Crimson, Phthalo Blue RS, Phthalo Green BS, Raw Umber, Titanium White, Ultramarine Blue, and Yellow Ochre.

NUMBER	EACH
A01630-1009	\$49.58

Utrecht™ artists' acrylics



Count on the same consistency, quality, and performance from batch to batch and year to year.

Utrecht™ Artists' Acrylic Colors

Among the first to develop and produce artists' acrylics, Utrecht has been making these professional-quality paints in Brooklyn, New York, since the late 1950s. Skilled craftspeople use only the finest pigments to create each and every color. The heavy-bodied paints offer excellent tinting strength, superior intensity and opacity, a buttery texture, and outstanding lightfastness. Colors can be assorted for quantity pricing.



COLOR	2 OZ (59 ML)	EACH	6/EA	5 OZ (150 ML)	EACH	6/EA	16 OZ (473 ML)	EACH	6/EA
Alizarin Crimson Hue	A01654-3072	\$13.57	\$12.21	A01654-3075	\$26.45	\$23.80	A01654-3076	\$72.99	\$65.71
Azo Yellow Medium	A01654-4022	13.57	12.21	—	—	—	—	—	—
Azo Yellow Orange	A01654-4012	13.57	12.21	—	—	—	—	—	—
Brilliant Blue	A01654-5062	8.66	7.79	A01654-5065	15.77	14.19	A01654-5066	33.25	29.93
Brilliant Green	A01654-7252	8.66	7.79	A01654-7255	15.77	14.19	A01654-7256	33.25	29.93
Burnt Sienna	A01654-8042	8.66	7.79	A01654-8045	15.77	14.19	A01654-8046	33.25	29.93
Burnt Umber	A01654-8052	8.66	7.79	A01654-8055	15.77	14.19	A01654-8056	33.25	29.93
Cadmium Green	A01654-7212	18.77	16.89	A01654-7215	37.30	33.57	—	—	—
Cadmium Orange Hue	A01654-4542	10.96	9.86	A01654-4545	20.08	18.07	A01654-4546	47.43	42.69
Cadmium Orange Pure	A01654-4532	18.77	16.89	A01654-4535	37.30	33.57	A01654-4536	81.62	73.46
Cadmium Red Extra Deep	A01654-3332	18.77	16.89	A01654-3335	37.30	33.57	A01654-3336	81.62	73.46
Cadmium Red Hue	A01654-3322	10.96	9.86	A01654-3325	20.08	18.07	A01654-3326	47.43	42.69
Cadmium Red Light Pure	A01654-3092	18.77	16.89	A01654-3095	37.30	33.57	A01654-3096	81.62	73.46
Cadmium Red Medium Pure	A01654-3112	18.77	16.89	A01654-3115	37.30	33.57	A01654-3116	81.62	73.46
Cadmium Yellow Deep Pure	A01654-4282	18.77	16.89	—	—	—	—	—	—
Cadmium Yellow Hue	A01654-4352	8.66	7.79	A01654-4355	15.77	14.19	A01654-4356	33.25	29.93
Cadmium Yellow Lemon Pure	A01654-4112	18.77	16.89	A01654-4115	37.30	33.57	—	—	—
Cadmium Yellow Light Pure	A01654-4072	13.57	12.21	A01654-4075	26.45	23.80	A01654-4076	72.99	65.71
Cadmium Yellow Medium Pure	A01654-4092	13.57	12.21	A01654-4095	26.45	23.80	A01654-4096	72.99	65.71
Cerulean Blue Chromium Pure	A01654-5182	18.77	16.89	A01654-5185	37.30	33.57	A01654-5186	81.62	73.46
Cerulean Blue Hue	A01654-5172	10.96	9.86	A01654-5175	20.08	18.07	A01654-5176	47.43	42.69
Chromium Oxide Green	A01654-7112	10.96	9.86	A01654-7115	20.08	18.07	A01654-7116	47.43	42.69
Cobalt Blue Hue	A01654-5192	8.66	7.79	A01654-5195	15.77	14.19	A01654-5196	33.25	29.93
Cobalt Blue Pure	A01654-5282	18.77	16.89	A01654-5285	37.30	33.57	A01654-5286	81.62	73.46
Dioxazine Purple	A01654-6022	13.57	12.21	A01654-6025	26.45	23.80	A01654-6026	72.99	65.71
Emerald Green	A01654-7052	10.96	9.86	—	—	—	—	—	—
Hansa Yellow Light	A01654-4962	8.66	7.79	A01654-4965	15.77	14.19	A01654-4966	33.25	29.93
Hansa Yellow Pale	A01654-4952	10.96	9.86	A01654-4955	20.08	18.07	A01654-4956	47.43	42.69
Hooker's Green Hue	A01654-7122	18.77	16.89	A01654-7125	37.30	33.57	A01654-7126	81.62	73.46
Indo Orange Red	A01654-4572	13.57	12.21	—	—	—	—	—	—
Iridescent Antique Bronze	A01654-8152	13.57	12.21	—	—	—	—	—	—
Iridescent Antique Copper	A01654-9512	13.57	12.21	—	—	—	—	—	—
Iridescent Antique Gold	A01654-9032	13.57	12.21	—	—	—	—	—	—
Iridescent Antique Silver	A01654-9322	13.57	12.21	—	—	—	—	—	—
Iridescent Bronze	A01654-9072	13.57	12.21	—	—	—	—	—	—
Iridescent Copper	A01654-9522	13.57	12.21	—	—	—	—	—	—
Iridescent Gold	A01654-9012	13.57	12.21	A01654-9015	26.45	23.80	A01654-9016	72.99	65.71
Iridescent Russet	A01654-3512	13.57	12.21	—	—	—	—	—	—
Iridescent Silver	A01654-9302	13.57	12.21	A01654-9305	26.45	23.80	A01654-9316	72.99	65.71
Iridescent White	A01654-1062	13.57	12.21	—	—	—	—	—	—
Ivory Black	A01654-2252	8.66	7.79	A01654-2255	15.77	14.19	A01654-2256	33.25	29.93
Light Pink	A01654-8172	8.66	7.79	A01654-8175	15.77	14.19	A01654-8176	33.25	29.93
Mars Black	A01654-2042	8.66	7.79	A01654-2045	15.77	14.19	A01654-2046	33.25	29.93
Medium Gray	A01654-2522	8.66	7.79	—	—	—	—	—	—
Naphthol Crimson	A01654-3222	10.96	9.86	A01654-3225	20.08	18.07	A01654-3226	47.43	42.69
Naphthol Red Light	A01654-3192	10.96	9.86	A01654-3195	20.08	18.07	A01654-3196	47.43	42.69
Payne's Gray	A01654-2562	8.66	7.79	A01654-2565	15.77	14.19	A01654-2566	33.25	29.93
Permanent Bronze	A01654-9602	13.57	12.21	—	—	—	—	—	—
Permanent Gold	A01654-4062	13.57	12.21	—	—	—	—	—	—
Permanent Green	A01654-7982	13.57	12.21	A01654-7985	26.45	23.80	A01654-7986	72.99	65.71
Permanent Silver	A01654-9332	13.57	12.21	—	—	—	—	—	—
Permanent Violet	A01654-6062	13.57	12.21	A01654-6065	26.45	23.80	A01654-6066	72.99	65.71
Phthalo Blue (GS)	A01654-5162	10.96	9.86	A01654-5165	20.08	18.07	A01654-5166	47.43	42.69
Phthalo Green (BS)	A01654-7802	10.96	9.86	A01654-7805	20.08	18.07	A01654-7806	47.43	42.69
Quinacridone Red	A01654-3272	13.57	12.21	A01654-3275	26.45	23.80	A01654-3276	72.99	65.71
Quinacridone Violet	A01654-6202	13.57	12.21	A01654-6205	26.45	23.80	A01654-6206	72.99	65.71
Raw Sienna	A01654-8062	8.66	7.79	A01654-8065	15.77	14.19	A01654-8066	33.25	29.93
Raw Umber	A01654-8072	8.66	7.79	A01654-8075	15.77	14.19	A01654-8076	33.25	29.93
Titanium White	A01654-1012	8.66	7.79	A01654-1015	15.77	14.19	A01654-1016	33.25	29.93
Turquoise	A01654-7912	10.96	9.86	A01654-7915	20.08	18.07	A01654-7916	47.43	42.69
Ultramarine Blue	A01654-5232	8.66	7.79	A01654-5235	15.77	14.19	A01654-5236	33.25	29.93
Unbleached Titanium Hue	A01654-1032	8.66	7.79	A01654-1035	15.77	14.19	A01654-1036	33.25	29.93
Venetian Red	A01654-3132	8.66	7.79	A01654-3135	15.77	14.19	A01654-3136	33.25	29.93
Viridian Hue	A01654-7512	8.66	7.79	A01654-7515	15.77	14.19	A01654-7516	33.25	29.93
Yellow Ochre	A01654-4302	8.66	7.79	A01654-4305	15.77	14.19	A01654-4306	33.25	29.93

Winsor & Newton™ Galeria™ Acrylics

Galeria flow-formula acrylics are available in a range of strong and vibrant colors at an affordable price. The paint is easily diluted with water or mediums and is suitable for a wide variety of techniques, from airbrushing to canvas and mural painting. Colors can be assorted for quantity pricing.

COLOR	2 OZ (60 ML)	6.76 OZ (200 ML)	8.5 OZ (250 ML)	16.9 OZ (500 ML)
Buff Titanium	A00604-8623	—	—	—
Burgundy	A00604-3143	—	—	—
Burnt Sienna	A00604-8043	A00604-8042	A00604-8044	A00604-8045
Burnt Sienna Opaque	A00604-8033	—	—	—
Burnt Umber	A00604-8053	A00604-8052	A00604-8054	A00604-8055
Cadmium Orange Hue	A00604-4543	A00604-4542	A00604-4544	A00604-4545
Cadmium Red Hue	A00604-3543	A00604-3542	A00604-3544	A00604-3545
Cadmium Ylw Dp Hue	A00604-4283	A00604-4282	A00604-4284	A00604-4285
Cadmium Ylw Med Hue	A006			



LIQUITEX

gel mediums

Modeling Paste — Ideal for sculptural applications and building heavy textures on rigid surfaces. Can be mixed with color or overpainted when dry.

NUMBER	SIZE	EACH	12/EA
A00618-1056	16 oz (473 ml)	\$20.86	\$18.77
A00618-1047	32 oz (946 ml)	32.20	28.98
A00618-3119	Gallon (3.78 Liter)	82.65	74.38

Light Modeling Paste — Use to add body to paint and create pastel tints. Dries to a matte opaque white.

NUMBER	SIZE	EACH	12/EA
A00609-1037	32 oz (946 ml)	\$30.83	\$27.75
A00609-1039	Gallon (3.78 Liter)	30.83	27.75

Flexible Modeling Paste — A matte, opaque mixture used to build heavy textures and 3-D forms on flexible or rigid supports.

NUMBER	SIZE	EACH	12/EA
A02002-1022	16 oz (473 ml)	\$21.28	\$19.15
A02002-1023	32 oz (946 ml)	26.10	23.49
A02002-1029	Gallon (3.78 Liter)	87.73	78.96

Gloss Gel — Dries crystal-clear for sparkling, transparent impastos and textured glazes.

NUMBER	SIZE	EACH	12/EA
A00618-1006	16 oz (473 ml)	\$21.99	\$19.81
A00618-3167	32 oz (946 ml)	38.65	34.78
A00618-3169	Gallon (3.78 Liter)	81.58	73.42

Gloss Heavy Gel — This extra-high viscosity medium extends paint. Dries transparent.

NUMBER	SIZE	EACH	12/EA
A00618-3176	16 oz (473 ml)	\$21.99	\$19.81

Gloss Super Heavy Gel — For collage and mixed media projects or to create sculptural effects.

NUMBER	SIZE	EACH	12/EA
A00618-3067	32 oz (946 ml)	\$38.65	\$34.78
A00618-3069	Gallon (3.78 Liter)	105.79	95.21

Matte Gel — Developed for translucent impastos. Dries to a satin/matte finish.

NUMBER	SIZE	EACH	12/EA
A00618-3086	16 oz (473 ml)	\$21.99	\$19.81
A00618-3087	32 oz (946 ml)	38.65	34.78
A00618-3089	Gallon (3.78 Liter)	81.58	73.42

Matte Super Heavy Gel — Extends volume and increases transparency. Slows drying time to a translucent finish that retains high peaks and crisp brush and knife strokes.

NUMBER	SIZE	EACH	12/EA
A02002-1012	16 oz (473 ml)	\$21.12	\$18.99
A02002-1013	32 oz (946 ml)	34.31	30.88

Ultra Matte Gel — Dries to a matte finish, maintaining color opacity. Use to extend paint up to double amounts without changing color position.

NUMBER	SIZE	EACH	12/EA
A02002-1001	16 oz (473 ml)	\$21.12	\$18.99

Slow-Dri Blending Gel — Heavy body gel used to extend open time by 40% for easier blending. Add up to 50% without changing the strength of paint film.

NUMBER	SIZE	EACH	12/EA
A00618-2055	8 oz (237 ml)	\$13.55	\$12.19

Satin Gel —

NUMBER	SIZE	EACH	12/EA
A02002-1051	8 oz (237 ml)	\$13.21	\$11.89

paint mediums

Gloss Medium — Improves the adhesion of paint film and increases color depth and intensity. Can also be used as a varnish.

NUMBER	SIZE	EACH	12/EA
A00618-3184	4 oz (118 ml)	\$8.77	\$7.89
A00618-3185	8 oz (237 ml)	13.55	12.19
A00618-1026	16 oz (473 ml)	21.99	19.81
A00618-1017	32 oz (946 ml)	38.65	34.78
A00618-3189	Gallon (3.78 Liter)	78.99	71.10

Palette Wetting Spray — Slows the drying time of acrylic color.

NUMBER	SIZE	EACH	12/EA
A02001-2002	8 oz (237 ml)	\$16.34	\$14.71

Glazing Medium — Use for maximum transparency to add luminosity and depth to paintings.

NUMBER	SIZE	EACH	12/EA
A00618-3137	32 oz (946 ml)	\$38.65	\$34.78

Matte Medium — Mix with colors to achieve a completely matte surface.

NUMBER	SIZE	EACH	12/EA
A00618-1036	16 oz (473 ml)	\$21.99	\$19.81
A00618-1027	32 oz (946 ml)	38.65	34.78
A00618-3219	Gallon (3.78 Liter)	78.99	71.10

Ultra Matte Medium — A fluid with high-resin solids that dries to a matte finish. Use to maintain opacity and extend opaque colors to double amounts without changing the color.

NUMBER	SIZE	EACH	12/EA
A00618-3125	8 oz (237 ml)	\$13.55	\$12.19

Slow-Dri Blending Medium — An essential medium for creating softer edges and modeled forms. Extends open time by more than 40%.

NUMBER	SIZE	EACH	12/EA
A00618-2046	16 oz (473 ml)	\$21.99	\$19.81

Satin Medium

NUMBER	SIZE	EACH	12/EA
A00618-3227	8 oz (237 ml)	\$13.55	\$12.19

Liquitex Acrylic Polymer Varnishes

Non-removable archival varnishes for interior and exterior use. Excellent leveling properties. Durable and non-yellowing. Translucent when wet but clear when dry. Avoid excessive brushwork to prevent clouding. May be spray-applied.

Gloss & Matte Varnishes

NUMBER	DESCRIPTION	EACH	12/EA
A00618-3026	16 oz (473 ml) Gloss	\$21.99	\$19.81
A00618-3027	32 oz (946 ml) Gloss	38.10	34.29
A00618-3029	Gallon (3.78 Liter) Gloss	112.05	100.85
A00618-1037	32 oz (946 ml) Matte	38.10	34.29
A00618-3039	Gallon (3.78 Liter) Matte	112.05	100.85

High Gloss Varnish

NUMBER	SIZE	EACH	12/EA
A00618-1099	32 oz (946 ml)	\$38.10	\$34.29

Satin Varnish

NUMBER	SIZE	EACH	12/EA
A00618-3048	32 oz (946 ml)	\$38.10	\$34.29

effects

A Pouring Medium — Designed to reduce crazing in poured applications, this fluid medium dries clear, glossy, and flexible.

NUMBER	SIZE	EACH	12/EA
A02001-1002	237 ml (8 oz)	\$16.34	\$14.71
A02001-1003	16 oz (473 ml)	25.88	23.29
A02001-1013	16 oz (473 ml)	25.88	23.29
A02001-1023	16 oz (473 ml)	25.88	23.29
A02001-1009	946 ml (32 oz)	40.27	36.24
A02001-2009	3.78 Liter (Gallon)	102.89	92.60

B Flow Aid Additive — Increases the flow, absorbency, and blending of any waterbased paint, ink, or dye. Minimizes brushstrokes.

NUMBER	SIZE	EACH	12/EA
A02002-1004	4 oz (118 ml)	\$9.12	\$8.20

C Liquithick Additive — Excellent for sculptural effects when a matte finish is desired.

NUMBER	SIZE	EACH	12/EA
A02002-1041	8 oz (237 ml)	\$13.21	\$11.89

D Fabric Medium — Provides smooth, consistent paint flow, eliminating dragging and skipping. Controls bleeding for transparent designs.

NUMBER	SIZE	EACH	12/EA
A00618-1014	4 oz (118 ml)	\$8.77	\$7.89

E Iridescent Medium — Turns ordinary transparent colors into vibrant metallics. Dries translucent and will not oxidize.

NUMBER	SIZE	EACH	12/EA
A00618-1025	8 oz (237 ml)	\$13.55	\$12.19

F String Gel — Honey-like consistency. Enhances depth of color while increasing transparency and flow.

NUMBER	SIZE	EACH	12/EA
A02002-1031	8 oz (237 ml)	\$13.21	\$11.89
A02002-1032	16 oz (473 ml)	21.12	18.99

Gold Metallic Medium -

NUMBER	SIZE	EACH	12/EA
A02003-9027	8 oz (237 ml)	\$14.63	\$13.17

Silver Metallic Medium -

NUMBER	SIZE	EACH	12/EA
A02003-9327	8 oz (237 ml)	\$14.63	\$13.17

Glass Medium -

NUMBER	SIZE	EACH	12/EA
A02003-1007	8 oz (237 ml)	\$14.63	\$13.17

Crackle Paste -

NUMBER	SIZE	EACH	12/EA
A02003-1017	8 oz (237 ml)	\$14.63	\$13.17

Masking Fluid -

NUMBER	SIZE	EACH	12/EA
A02003-1008	4 oz (118 ml)	\$8.50	\$7.65

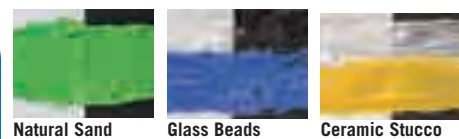

Liquitex Texture Effects Mediums

These versatile mediums contain particles that produce a variety of unique textural and dimensional effects. 8 oz (237 ml).

NUMBER	DESCRIPTION	EACH	12/EA
A00609-1015	Ceramic Stucco	\$12.85	\$11.57
A00609-1025	Glass Beads	12.85	11.57
A00618-1075	Natural Sand	13.06	11.75

2 oz (59 ml) Tubes

NUMBER	COLOR	EACH
A00617-3464	Deep Magenta	\$13.59
A00617-6614	Deep Violet	13.59
A00617-6024	Dioxazine Purple	11.25
A00617-7054	Emerald Green	11.25
A00617-7084	Green Deep Permanent	11.25
A00617-7713	Hkr's Grn Dp Hue Perm	8.99
A00617-7354	Hooker's Grn Hue Perm	8.99
A00617-9133	Iridescent Antique Gold	11.25
A00617-9014	Iridescent Bright Gold	11.25
A00617-9314	Iridescent Bright Silver	11.25
A00617-9603	Iridescent Rich Bronze	11.25
A00617-9513	Iridescent Rich Copper	11.25
A00617-9103	Iridescent Rich Gold	11.25
A00617-1134	Iridescent White	11.25
A00617-2254	Ivory Black	8.99
A00617-5434	Light Blue Permanent	8.99
A00617-6594	Light Blue Violet	8.99
A00617-7754	Light Emerald Green	13.59
A00617-3304	Light Pink	8.99
A00617-5334	Manganese Blue Hue	13.59
A00617-2044	Mars Black	8.99
A00617-3314	Medium Magenta	8.99
A00617-2505	Muted Gray	13.59
A00617-7035	Muted Green	13.59
A00617-3065	Muted Pink	13.59
A00617-5115	Muted Turquoise	13.59
A00617-6515	Muted Violet	13.59
A00617-3224	Naphthol Crimson	11.25
A00617-3194	Naphthol Red Light	11.25
A00617-4784	Naples Yellow Hue	11.25
A00617-2604	Neutral Gray Value 5	8.99
A00617-7384	Parchment	8.99
A00617-2564	Payne's Gray	8.99
A00617-5144	Phthalo Blue GS	8.99
A00617-7064	Phthalo Green BS	8.99
A00617-7573	Phthalo Green YS	8.99
A00617-6544	Prism Violet	11.25
A00617-5224	Prussian Blue Hue	11.25
A00617-6603	Quina Blue Violet	13.59
A00617-4503	Quina Burnt Orange	13.59
A00617-3393	Quinacridone Crimson	13.59
A00617-6563	Quinacridone Magenta	13.59
A00617-3524	Quinacridone Red	13.59
A00617-3383	Quina Red Orange	13.59
A00617-8064	Raw Sienna	8.99
A00617-8074	Raw Umber	8.99
A00617-3124	Red Oxide	8.99
A00617-7394	Sap Green Permanent	11.25
A00617-1014	Titanium White	8.99
A00617-8774	Trans Burnt Sienna	13.59
A00617-8784	Trans Burnt Umber	11.25
A00617-8164	Trans Mixing White	8.99
A00617-8174	Trans Raw Sienna	13.59
A00617-8174	Transparent Raw Umber	11.25
A00617-7194	Trans Viridian Hue	11.25
A00617-4414	Turner's Yellow	11.25
A00617-5404	Turquoise Deep	11.25
A00617-5234	Ultramarine Blue GS	8.99
A00617-5273	Ultramarine Blue RS	8.99
A00617-4344	Unbleached Titanium	8.99



Liquitex Professional Heavy Body Acrylics

A thick and creamy heavy-body acrylic that retains crisp brushstrokes, high peaks, and knife marks.

2 oz (59 ml) Tubes

NUMBER	COLOR	EACH
A00617-3534	Aliz Crimson Hue Perm	\$11.25
A00617-7204	Bright Aqua Green	8.99
A00617-5064	Brilliant Blue	8.99
A00617-6074	Brilliant Purple	8.99
A00617-7614	Brilliant Yellow Green	8.99
A00617-9624	Bronze Yellow	8.99
A00617-8043	Burnt Sienna	8.99
A00617-8054	Burnt Umber	8.99
A00617-4534	Cadmium Orange	18.25
A00617-3094	Cadmium Red Light	18.89
A00617-3104	Cadmium Red Medium	18.89
A00617-4074	Cadmium Yellow Light	13.59
A00617-4094	Cadmium Yellow Medium	13.59
A00617-4515	Cadmium-Free Orange	18.25
A00617-3755	Cadmium-Free Red Dp	18.25
A00617-3015	Cadmium-Free Red Lt	18.89
A00617-3745	Cadmium-Free Red Med	18.89
A00617-4325	Cadmium-Free Yellow Dp	13.59

GOLDEN®



Golden® Acrylic Gesso

Ready-to-use liquid ground for use on common painting surfaces. Can be modified by mixing it with a variety of mediums. Apply it with brush, roller, trowel, or spray gun. At least three layers of gesso are needed for oil painting.

NUMBER	DESCRIPTION	EACH
A00628-1037	White, 32 oz (0.9 Liter)	\$35.74
A00628-1039	White, Gallon (3.78 Liter)	90.85
A00628-1177	Black, 32 oz (0.9 Liter)	41.73
A00628-1179	Black, Gallon (3.78 Liter)	117.38

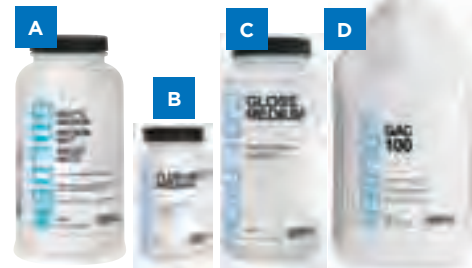

A Golden® Matte Medium

Using Polymer Mediums will extend, thin, and promote flow and leveling of your paints while maintaining the film's stability. Mix the gloss and matte to create a custom satin finish.

NUMBER	DESCRIPTION	EACH
A00628-1125	8 oz (237 ml)	\$14.69
A00628-1126	16 oz (473 ml)	25.06
A00628-1127	32 oz (946 ml)	36.82
A00628-1129	Gallon (3.78 Liter)	93.56

B Golden® Fluid Matte Medium

This liquid medium decreases gloss and extends Golden Fluid Acrylics without altering their consistency.

NUMBER	SIZE	EACH
A00628-1108	8 oz (237 ml)	\$14.69
A00628-1107	32 oz (946 ml)	36.82
A00628-2109	Gallon (3.78 Liter)	100.11

C Golden® Polymer Gloss Medium

Use this glossy polymer medium to extend, thin, and promote the flow and leveling of your paints.

NUMBER	SIZE	EACH
A00628-1115	8 oz (237 ml)	\$15.48
A00628-2136	16 oz (473 ml)	26.29
A00628-2137	32 oz (946 ml)	38.30
A00628-2139	Gallon (3.78 ml)	100.11

D Golden® GAC100-Universal Acrylic Polymer

GAC100 is useful in diluting and extending acrylic paints as well as increasing flexibility and film stability. Breaks down Heavy Body paints faster than other polymers.

NUMBER	SIZE	EACH
A00628-1007	32 oz (946 ml)	\$36.82
A00628-1009	D Gallon (3.78 Liter)	93.56



Gel Acrylic Mediums mixed with Manganese Blue Hue

E-I Golden® Gels

E Soft Gel Acrylic Medium — Thinner than Heavy Body Acrylic Paint. Can be poured from the jar. Excellent glue for collage.

NUMBER	DESCRIPTION	EACH
A00628-1097	Gloss, 32 oz (946 ml)	\$38.30
A00628-1099	Gloss, Gallon (3.78 Liter)	100.11
A00628-1239	Matte, Gallon (3.78 Liter)	100.11

F Regular Gel Acrylic Medium — Same thickness as Heavy Body acrylic. Mix for glazing. Dries translucent. Can hold soft peaks.

NUMBER	DESCRIPTION	EACH
A00628-1087	Gloss, 32 oz (946 ml)	\$38.30
A00628-1089	Gloss, Gallon (3.78 Liter)	100.11
A00628-1079	Matte, Gallon (3.78 Liter)	100.11

G Heavy Gel Acrylic Medium — Thicker than Heavy Body acrylic color. Holds peaks. Dries translucent.

NUMBER	DESCRIPTION	EACH
A00628-1139	Gloss, Gallon (3.78 Liter)	\$100.11
A00628-1149	Matte, Gallon (3.78 Liter)	100.11

H Extra Heavy Gel Acrylic Medium — Same as Heavy Body, but creates thicker, permanent textures. Dries translucent.

NUMBER	DESCRIPTION	EACH
A00628-1309	Gloss, Gallon (3.78 Liter)	\$100.11

I High Solid Gel Medium — The thickest of the gels. Holds high peaks.

NUMBER	DESCRIPTION	EACH
A00628-1325	Gloss, 8 oz (237 ml)	\$17.16
A00628-1327	Gloss, 32 oz (946 ml)	43.50
A00628-1329	Gloss, Gallon (3.78 Liter)	122.56



J Golden® Introductory Set of 6

Included in this convenient introductory set are 2 oz (60 ml) jars of Soft Gel (Gloss), Regular Gel (Semi-Gloss), Extra Heavy Gel (Matte), Light Molding Paste, Coarse Pumice Gel, and Clear Tar Gel.

NUMBER	EACH
A00628-2069	\$29.23

K Golden® Pouring Mediums

A low-crazing extender for creating acrylic pours and puddles. This medium has a gloss or matte finish with good flexibility. It also improves adhesion to chalky surfaces.

NUMBER	DESCRIPTION	SIZE	EACH
A00628-2305	Gloss	8 oz (237 ml)	\$14.69
A00628-2306	Gloss	16 oz (473 ml)	25.06
A00628-2307	Gloss	32 oz (946 ml)	36.82
A00628-2309	Gloss	Gallon (3.78 Liter)	93.56
A00628-2405	Matte	8 oz (237 ml)	14.69
A00628-2406	Matte	16 oz (473 ml)	25.06
A00628-2407	Matte	32 oz (946 ml)	36.82
A00628-2409	Matte	Gallon (3.78 Liter)	93.56

L-M Golden® Molding Paste Mediums

L Molding Paste — Molding Paste (sometimes referred to as Modeling Paste) holds stiff peaks to create a highly textured surface. Dries hard and opaque.

NUMBER	SIZE	EACH
A00628-1167	32 oz (946 ml)	\$36.82
A00628-1169	Gallon (3.78 Liter)	93.56

Molding Paste mixed with Phthalo Green (Blue Shade)

M Light Molding Paste — Drastically reduces the weight traditional Molding Paste would add, while increasing flexibility.

NUMBER	SIZE	EACH
A00628-1057	32 oz (946 ml)	\$36.82
A00628-1059	Gallon (3.78 Liter)	93.56

Light Molding Paste mixed with Quinacridone Crimson



Pumice Gel mixed with Permanent Green Light

N-O Golden® Pumice Gel Acrylic Mediums

Volcanic pumice mixed with Gel Medium produces wonderful gritty textures. 8 oz (237 ml) jars.

NUMBER	DESCRIPTION	EACH
A00628-1025	N Fine	\$16.11
A00628-1015	O Coarse	15.48
A00628-1345	P Extra Coarse	15.48



Q Golden® Acrylic Glazing Liquid

Blend of GAC100 Polymer and Golden Retarder. This product offers the greatest amount of work time without running the risk of adding too much retarder. Great for creating glazes or faux finishes on interior walls, furniture, or for glazing fine art paintings.

NUMBER	SIZE	EACH
A00628-1016	16 oz Gloss (473 ml)	\$19.13
A00628-1026	16 oz Satin (473 ml)	19.13
A00628-1017	32 oz Gloss (946 ml)	28.67
A00628-1027	32 oz Satin (946 ml)	28.67

R Golden® Clear Tar Gel

Designed to produce a stringy, tar-like feel in a colorless gel, this medium is excellent for "dripping" over surfaces.

NUMBER	SIZE	EACH
A00628-1367	32 oz (473 ml)	\$41.73
A00628-1369	Gallon (3.78 Liter)	117.38

S Golden® Polymer Varnish

This acrylic polymer varnish dries to a protective, flexible, dust-resistant surface. Use it as a final sealant over acrylic paint.

NUMBER	SIZE	EACH
A00628-1189	Gallon (3.78 Liter)	\$128.36

GOLDEN®

Golden® Heavy Body Artist Acrylics

Known for their exceptionally smooth, thick, and buttery consistency, these acrylics have the ability to "stand up" and retain brushstrokes or knife marks on canvas. The colors in this line adhere to modern standards of safety, lightfastness, and permanence.

59 ml (2 oz) Tubes

NUMBER	COLOR	EACH
A00620-5913	Anthraquinone Blue	\$16.24
A00620-4453	Benzimidazolone Yellow Lt	11.05
A00620-4233	Benzimidazolone Yellow Med	11.05
A00620-4613	Bismuth Vanadate Ylw	20.99
A00620-2103	Bone Black	9.53
A00620-8043	Burnt Sienna	9.53
A00620-8053	Burnt Umber	9.53
A00620-8673	Burnt Umber Light	9.53
A00620-2123	Carbon Black	9.53
A00620-5923	Cerulean Blue Chrom	16.24
A00620-5163	Cerulean Blue Deep	20.99
A00620-7953	Chrom Oxide Green Dk	11.05
A00620-7113	Chromium Oxide Green	11.05
A00620-5183	Cobalt Blue	18.63
A00620-5193	Cobalt Blue Hue	10.78
A00620-7163	Cobalt Green	12.08
A00620-5883	Cobalt Teal	16.24
A00620-5373	Cobalt Turquoise	18.63
A00620-3233	CP Cad Red Med Hue	12.08
A00620-4953	CP Cad Yellow Dark	16.24
A00620-4963	CP Cad Yellow Light	16.24
A00620-4973	CP Cad Yellow Medium	16.24
A00620-4193	CP Cad Ylw Med Hue	12.08
A00620-4983	CP Cad Ylw Primrose	16.24
A00620-4913	CP Cadmium Orange	18.63
A00620-3713	CP Cadmium Red Dark	20.99
A00620-3723	CP Cadmium Red Light	20.99
A00620-3733	CP Cadmium Red Med	20.99
A00620-4493	Diarylide Yellow	14.81
A00620-6023	Dioxazine Purple	14.81
A00620-2613	Graphite Gray	10.78
A00620-9063	Green Gold	16.24
A00620-7933	Jenkins Green	16.24
A00620-4603	Light Bismuth Yellow	12.08
A00620-7683	Light Green BS	11.05
A00620-7693	Light Green YS	11.05
A00620-3583	Light Magenta	10.78
A00620-4513	Light Orange	12.08
A00620-5173	Light Phthalo Blue	9.53
A00620-7803	Light Phthalo Green	9.53
A00620-6533	Light Violet	11.05
A00620-5973	Lt Turquoise Phthalo	11.05
A00620-5233	Lt Ultramarine Blue	10.78
A00620-2043	Mars Black	9.53
A00620-4383	Mars Yellow	9.53
A00620-3043	Medium Magenta	14.81
A00620-6523	Medium Violet	14.81
A00620-2423	Neutral Gray N2	9.53

59 ml (2 oz) Tubes

NUMBER	COLOR	EACH
A00620-2433	Neutral Gray N3	\$9.53
A00620-2443	Neutral Gray N4	9.53
A00620-2603	Neutral Gray N5	9.53
A00620-2463	Neutral Gray N6	9.53
A00620-2473	Neutral Gray N7	9.53
A00620-2483	Neutral Gray N8	9.53
A00620-4993	Nickel Azo Yellow	14.81
A00620-2563	Paynes Gray	10.78
A00620-7083	Permanent Green Light	12.08
A00620-3333	Permanent Maroon	16.24
A00620-6923	Permanent Violet Dark	16.24
A00620-5943	Phthalo Blue GS	12.08
A00620-5743	Phthalo Blue RS	12.08
A00620-7183	Phthalo Green BS	12.08
A00620-7563	Phthalo Green YS	12.08
A00620-5953	Primary Cyan	10.78
A00620-3763	Primary Magenta	14.81
A00620-4533	Primary Yellow	10.78
A00620-4503	Pyrrrole Orange	18.63
A00620-3773	Pyrrrole Red	18.63
A00620-3673	Pyrrrole Red Dark	18.63
A00620-3693	Pyrrrole Red Light	18.63
A00620-4783	Quina Burnt Orange	16.24
A00620-9083	Quina Nickel Azo Gold	16.24
A00620-3783	Quinacridone Crimson	16.24
A00620-3623	Quinacridone Magenta	16.24
A00620-3273	Quinacridone Red	14.81
A00620-3793	Quinacridone Red Lt	16.24
A00620-6513	Quinacridone Violet	14.81
A00620-8063	Raw Sienna	9.53
A00620-8073	Raw Umber	9.53
A00620-3123	Red Oxide	9.53
A00620-5073	Teal	11.05
A00620-7023	Titan Green Pale	9.53
A00620-2053	Titan Mars Pale	9.53
A00620-6543	Titan Violet Pale	9.53
A00620-5003	Titanate Yellow	9.53
A00620-8913	Titanium Buff	9.53
A00620-1013	Titanium White	9.53
A00620-8933	Trans Brown Iron Ox	11.05
A00620-3703	Trans Red Iron Oxide	11.05
A00620-5133	Ultramarine Blue	10.78
A00620-6643	Ultramarine Violet	12.08
A00620-4943	Vat Orange	18.63
A00620-6913	Violet Oxide	9.53
A00620-4043	Yellow Ochre	9.53
A00620-4113	Yellow Oxide	9.53
A00620-1033	Zinc White	9.53

Golden® Heavy Body Artist Acrylics Fluorescent Colors

4 oz (118 ml) Tubes

NUMBER	COLOR	EACH
A00620-5244	Fluorescent Blue	\$21.56
A00620-4344	Fluorescent Chartreuse	21.56
A00620-7274	Fluorescent Green	21.56
A00620-3344	Fluorescent Magenta	21.56
A00620-4564	Fluorescent Orange	21.56
A00620-4594	Fluorescent Org Ylw	21.56
A00620-3484	Fluorescent Pink	21.56
A00620-3814	Fluorescent Red	21.56
A00620-7264	Phosphorescent Green	27.06

Interference Colors — 2 oz (59 ml) tubes.

NUMBER	COLOR	EACH
A00620-5933	Blue	\$16.24
A00620-9203	Gold	16.24
A00620-7923	Green	16.24
A00620-6503	Purple	16.24

Iridescent Colors — 2 oz (59 ml) tubes.

NUMBER	COLOR	EACH
A00620-9613	Bronze-Fine	\$16.24
A00620-9533	Copper-Fine	16.24
A00620-9523	Copper Light-Fine	16.24
A00620-9013	Gold-Fine	14.81
A00620-9213	Bright Gold-Fine	16.24
A00620-1133	Pearl-Fine	12.08
A00620-9313	Silver-Fine	13.08
A00620-9333	Stainless Steel-Coarse	13.08

Neutral Grays — 2 oz (59 ml) tubes.

NUMBER	COLOR	EACH
A00620-2423	Neutral Gray N2	\$9.53
A00620-2433	Neutral Gray N3	9.53
A00620-2443	Neutral Gray N4	9.53
A00620-2603	Neutral Gray N5	9.53
A00620-2463	Neutral Gray N6	9.53
A00620-2473	Neutral Gray N7	9.53
A00620-2483	Neutral Gray N8	9.53



GOLDEN



Golden Open Acrylics

Golden Open is a professional line of colors and mediums formulated with a unique, relaxed set of working properties that stay wet longer, even in outdoor conditions. Their versatility allows artists to explore a wider range of techniques that rely on softening, shading, glazing, and creating fine detail. Colors can be assorted for quantity pricing.

4 oz (118 ml) Jars				2 oz (59 ml) Tubes				2 oz (59 ml) Tubes			
NUMBER	COLOR	EACH	6/EA	NUMBER	COLOR	EACH	6/EA	NUMBER	COLOR	EACH	6/EA
A01618-3444	Alizarin Crimson Hue	\$25.75	\$23.17	A01618-3443	Alizarin Crimson Hue	\$15.83	\$14.25	A01618-2543	Neutral Gray N5	9.24	8.32
A01618-4454	Benz Yellow Lt	15.91	14.31	A01618-5913	Anthraquinone Blue	15.83	14.25	A01618-4993	Nickel Azo Yellow	14.35	12.92
A01618-2104	Bone Black	13.99	12.59	A01618-4293	Aureolin Hue	10.54	9.48	A01618-2563	Payne's Gray	9.95	8.95
A01618-8044	Burnt Sienna	13.99	12.59	A01618-4453	Benz Yellow Light	10.75	9.67	A01618-7313	Permanent Green Light	11.69	10.52
A01618-8054	Burnt Umber	13.99	12.59	A01618-4913	Benz Yellow Medium	10.75	9.67	A01618-3343	Permanent Maroon	15.83	14.25
A01618-4094	C.P. Cad Yellow Med	25.75	23.17	A01618-4613	Bismuth Vanadate Ylw	20.42	18.38	A01618-6923	Permanent Violet Dark	15.83	14.25
A01618-4944	C.P. Cad Ylw Primrose	25.75	23.17	A01618-2103	Bone Black	9.24	8.32	A01618-5753	Phthalo Blue (GS)	11.69	10.52
A01618-4534	C.P. Cadmium Orange	28.23	25.41	A01618-8043	Burnt Sienna	9.24	8.32	A01618-5743	Phthalo Blue (RS)	11.69	10.52
A01618-3094	C.P. Cadmium Red Lt	31.46	28.32	A01618-8053	Burnt Umber	9.24	8.32	A01618-7803	Phthalo Green (BS)	11.69	10.52
A01618-3104	C.P. Cadmium Red Medium	31.46	28.32	A01618-4533	C.P. Cadmium Orange	18.09	16.30	A01618-7573	Phthalo Green (YS)	11.69	10.52
A01618-2124	Carbon Black	13.99	12.59	A01618-3713	C.P. Cadmium Red Drk	20.42	18.38	A01618-5223	Prussian Blue Hue	11.69	10.52
A01618-5924	Cerulean Blue Chromium	25.75	23.17	A01618-3093	C.P. Cadmium Red Lt	20.42	18.38	A01618-4623	Pyrrrole Orange	18.09	16.30
A01618-7654	Chromium Oxide Green	16.37	14.73	A01618-3103	C.P. Cadmium Red Med	20.42	18.38	A01618-3773	Pyrrrole Red	18.09	16.30
A01618-5184	Cobalt Blue	28.23	25.41	A01618-4953	C.P. Cadmium Ylw Dark	15.83	14.25	A01618-3753	Pyrrrole Red Dark	18.09	16.30
A01618-6024	Dioxazine Purple	23.09	20.79	A01618-4093	C.P. Cadmium Ylw Med	15.83	14.25	A01618-9013	Quina/Nickel Azo Gold	15.83	14.25
A01618-9174	Green Gold	25.75	23.17	A01618-4943	C.P. Cadmium Ylw Prim	15.83	14.25	A01618-4783	Quinacridone Burnt Org	15.83	14.25
A01618-4724	Indian Yellow Hue	17.78	15.99	A01618-2123	Carbon Black	9.24	8.32	A01618-3783	Quinacridone Crimson	15.83	14.25
A01618-7934	Jenkins Green	25.75	23.17	A01618-5923	Cerulean Blue Chrom	15.83	14.25	A01618-3623	Quinacridone Magenta	15.83	14.25
A01618-5334	Manga Blue Hue	13.99	12.59	A01618-7663	Chromium Ox Grn Drk	10.71	9.63	A01618-3273	Quinacridone Red	14.35	12.92
A01618-3744	Naphthol Red Medium	20.27	18.25	A01618-7653	Chromium Oxide Green	10.71	9.63	A01618-8063	Raw Sienna	9.24	8.32
A01618-4244	Naples Yellow Hue	15.16	13.64	A01618-5183	Cobalt Blue	18.09	16.30	A01618-8073	Raw Umber	9.24	8.32
A01618-4994	Nickel Azo Yellow	23.09	20.79	A01618-7163	Cobalt Green	11.69	10.52	A01618-3123	Raw Oxide	9.24	8.32
A01618-2564	Payne's Gray	15.16	13.64	A01618-5373	Cobalt Turquoise	18.09	16.30	A01618-7093	Sap Green Hue	11.69	10.52
A01618-5754	Phthalo Blue (GS)	17.78	15.99	A01618-4493	Diarylide Yellow	14.35	12.92	A01618-5073	Seal	10.71	9.63
A01618-7804	Phthalo Green (BS)	17.78	15.99	A01618-6023	Dioxazine Purple	14.35	12.92	A01618-7133	Terre Verte Hue	9.24	8.32
A01618-3774	Pyrrrole Red	28.23	25.41	A01618-9173	Green Gold	15.83	14.25	A01618-7703	Titan Green Pale	9.24	8.32
A01618-9014	Quina/Nickel Azo Gold	25.75	23.17	A01618-4723	Indian Yellow Hue	11.69	10.52	A01618-8913	Titanium Buff	9.24	8.32
A01618-3624	Quinacridone Magenta	25.75	23.17	A01618-9213	Irid Bright Gold (Fine)	15.83	14.25	A01618-1023	Titanium White	9.24	8.32
A01618-8064	Raw Sienna	13.99	12.59	A01618-8153	Irid Bronze (Fine)	15.83	14.25	A01618-8903	Trans Brown Iron Oxide	10.71	9.63
A01618-8074	Raw Umber	13.99	12.59	A01618-8123	Irid Copper (Fine)	15.83	14.25	A01618-3763	Trans Red Iron Oxide	10.71	9.63
A01618-3124	Red Oxide	13.99	12.59	A01618-9023	Irid Gold (Fine)	14.35	12.92	A01618-4903	Trans Yellow Iron Oxide	10.71	9.63
A01618-7094	Sap Green Hue	17.78	15.99	A01618-1133	Irid Pearl (Fine)	11.69	10.52	A01618-5233	Ultramarine Blue	9.95	8.95
A01618-8914	Titanium Buff	13.99	12.59	A01618-9333	Irid Silver (Fine)	12.68	11.41	A01618-6733	Ultramarine Violet	11.69	10.52
A01618-1024	Titanium White	13.99	12.59	A01618-7913	Jenkins Green	15.83	14.25	A01618-8923	VanDyke Brown Hue	10.71	9.63
A01618-3764	Trans Red Iron Oxide	16.37	14.73	A01618-5303	Light Ultra Blue	9.95	8.95	A01618-6913	Violet Oxide	9.24	8.32
A01618-5234	Ultramarine Blue	15.16	13.64	A01618-5333	Manga Blue Hue	9.24	8.32	A01618-7193	Viridian Green Hue	9.24	8.32
A01618-8924	VanDyke Brown Hue	16.37	14.73	A01618-4383	Mars Yellow	9.24	8.32	A01618-4043	Yellow Ochre	9.24	8.32
A01618-7194	Viridian Green Hue	13.99	12.59	A01618-3193	Naphthol Red Light	12.68	11.41	A01618-4113	Yellow Oxide	9.24	8.32
A01618-4044	Yellow Ochre	13.99	12.59	A01618-3743	Naphthol Red Medium	\$12.68	\$11.41	A01618-1033	Zinc White 1	9.24	8.32
				A01618-4243	Naples Yellow Hue	9.95	8.95				

GOLDEN

Golden High Flow Acrylics

Incredibly flexible, Golden High Flow Acrylics have an ink-like consistency that lends itself to a wide range of techniques — painting, drawing, staining, glazing, inking, hand-lettering, spraying, and more. They move effortlessly from airbrush to dip pen, from paintbrush to refillable marker, and from fine line detail to broad strokes. Offered in a palette of 49 colors, including four iridescents and five fluorescents, they are fully compatible with Golden Heavy Body, Fluid, and Open Acrylics as well as Golden Mediums.

COLOR	1 OZ (30 ML)	EACH	4 OZ (120 ML)	EACH	16 OZ (473 ML)	EACH
Alizarin Crimson Hue	A01650-3441	\$9.49	A01650-3444	\$26.68	A01650-3447	\$79.67
Benz Yellow Lt	A01650-4931	6.71	A01650-4934	15.52	A01650-4937	43.28
Benz Yellow Med	A01650-4601	6.71	A01650-4604	15.52	A01650-4607	43.28
Burnt Sienna	A01650-8041	6.23	A01650-8044	14.71	A01650-8047	38.90
Carbon Black	A01650-2121	6.23	A01650-2124	14.71	A01650-2127	38.90
Cerulean Blue Hue	A01650-5171	6.71	A01650-5174	16.95	A01650-5177	48.76
Diarylide Yellow	A01650-4491	8.65	A01650-4494	24.15	A01650-4497	70.07
Fluorescent Blue	A01650-5241	7.57	A01650-5244	21.40	A01650-5247	61.73
Fluorescent Chartreuse	A01650-4911	7.57	A01650-4914	21.40	A01650-4917	61.73
Fluorescent Green	A01650-7271	7.57	A01650-7274	21.40	A01650-7277	61.73
Fluorescent Orange	A01650-4561	7.57	A01650-4564	21.40	A01650-4567	61.73
Fluorescent Pink	A01650-3721	7.57	A01650-3724	21.40	A01650-3727	61.73
Green Gold	A01650-7171	9.49	A01650-7174	26.68	A01650-7177	79.67
Indigo (Anthraquinone)	A01650-5911	9.49	A01650-5914	26.68	A01650-5917	79.67
Iridescent Copper (Fine)	A01650-9521	9.49	A01650-9524	26.68	A01650-9527	79.67
Iridescent Gold (Fine)	A01650-9011	8.65	A01650-9014	24.15	A01650-9017	70.07
Iridescent Pearl (Fine)	A01650-1131	7.15	A01650-1134	18.76	A01650-1137	54.81
Iridescent Silver (Fine)	A01650-9311	7.57	A01650-9314	21.40	A01650-9317	61.73
Naphthol Red Light	A01650-3191	7.57	A01650-3194	21.40	A01650-3197	61.73
Neutral Grey N5	A01650-2551	6.23	A01650-2554	14.71	A01650-2557	38.90
Nickel Azo Yellow	A01650-4991	8.65	A01650-4994	24.15	A01650-4997	70.07
Permanent Green Light	A01650-7311	7.15	A01650-7314	18.76	A01650-7317	54.81
Permanent Violet Dark	A01650-6921	9.49	A01650-6924	26.68	A01650-6927	79.67
Phthalo Blue (GS)	A01650-5941	7.15	A01650-5944	18.76	A01650-5947	54.81
Phthalo Green (BS)	A01650-7181	7.15	A01650-7184	18.76	A01650-7187	54.81
Pyrrrole Orange	A01650-4591	9.99	A01650-4594	29.21	A01650-4597	89.09
Quina/Nickel Azo Gold	A01650-9091	9.49	A01650-9094	26.68	A01650-9097	79.67
Quinacridone Magenta	A01650-3621	9.49	A01650-3624	26.68	A01650-3627	79.67
Quinacridone Red	A01650-3271	8.65	A01650-3274	24.15	A01650-3277	70.07
Raw Sienna	A01650-8061	6.23	A01650-8064	14.71	A01650-8067	38.90
Raw Umber	A01650-8071	6.23	A01650-8074	14.71	A01650-8077	38.90
Sap Green Hue	A01650-7091	7.15	A01650-7094	18.76	A01650-7097	54.81
Sepia	A01650-8081	6.58	A01650-8084	15.90	A01650-8087	46.15
Teal	A01650-5081	6.71	A01650-5084	16.95	A01650-5087	48.76
Titanium Buff	A01650-8911	6.23	A01650-8914	14.71	A01650-8917	38.90
Titanium White	A01650-1021	6.23	A01650-1024	14.71	A01650-1027	38.90
Transp Benz Ylw Med	A01650-4451	6.23	A01650-4454	13.26	A01650-4457	34.94
Transp Brown Iron Ox	A01650-8481	6.23	A01650-8484	14.71	A01650-8487	38.90
Transp Diox Purple	A01650-6091	6.23	A01650-6094	14.71	A01650-6097	38.90
Transp Naphthol Red Lt	A01650-3181	6.23	A01650-3184	14.71	A01650-3187	38.90
Transp Phthalo Blue (GS)	A01650-5951	6.23	A01650-5954	14.71	A01650-5957	38.90
Transp Phthalo Grn (BS)	A01650-7191	6.23	A01650-7194	14.71	A01650-7197	38.90
Transp Quina Red	A01650-3281	6.23	A01650-3284	14.71	A01650-3287	38.90
Transp Red Iron Oxide	A01650-3761	6.23	A01650-3764	14.71	A01650-3767	38.90
Transp Shading Gray	A01650-2541	6.23	A01650-2544	14.71	A01650-2547	38.90
Transp Yellow Iron Ox	A01650-4121	6.23	A01650-4124	14.71	A01650-4127	38.90
Turquoise (Phthalo)	A01650-5961	7.15	A01650-5964	18.76	A01650-5967	54.81
Ultramarine Blue	A01650-5231	6.58	A01650-5234	15.90	A01650-5237	46.15
Yellow Oxide	A01650-4111	6.23	A01650-4114	14.71	A01650-4117	38.90

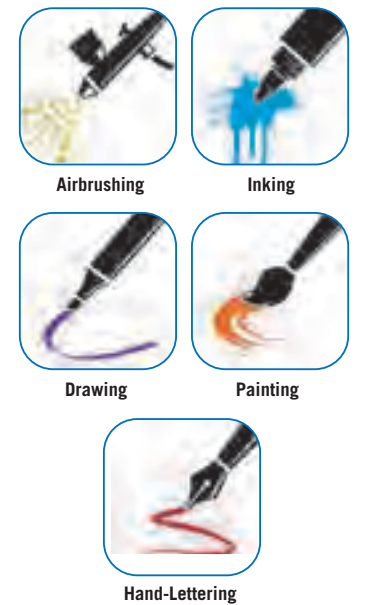

Hand-Lettering



Introductory Set of 6, Traditional Colors — Contains six 0.75 oz (22 ml) tubes: Indian Yellow Hue, Alizarin Crimson Hue, Ultramarine Blue, Sap Green Hue, VanDyke Brown Hue, and Titanium White.

NUMBER	EACH	6/EA
A01618-2069	\$31.07	\$27.98



Landscape Set — An ideal outdoor palette. Set includes seven 0.75 oz (22 ml) tubes of Open Acrylic, a 2 oz (59 ml) tube of Titanium White, and a 1 oz (30 ml) bottle of Open Thinner. For set colors, visit DickBlick.com.

NUMBER	EACH	6/EA
A01618-1019	\$46.69	\$42.03



LIQUITEX

Liquitex Professional Soft Body Acrylics
Soft Body Acrylics are equal to Heavy Body Acrylics in the amount and volume of pigment by weight. They dry to a smooth, even surface with good leveling, revealing little or no brush marks. Colors are UV-resistant with low odor and no fumes.



2 oz (59 ml) Bottles			2 oz (59 ml) Bottles		
NUMBER	COLOR	EACH	NUMBER	COLOR	EACH
A00616-3533	Alzrn Crmsn Hue Perm	\$11.21	A00616-2043	Mars Black	\$8.99
A00616-7203	Bright Aqua Green	8.99	A00616-3313	Medium Magenta	8.99
A00616-5063	Brilliant Blue	8.99	A00616-7039	Muted Green	13.52
A00616-6073	Brilliant Purple	8.99	A00616-2509	Muted Grey	13.52
A00616-4753	Brilliant Yellow Green	8.99	A00616-3069	Muted Pink	13.52
A00616-9623	Bronze Yellow	8.99	A00616-5119	Muted Turquoise	13.52
A00616-8043	Burnt Sienna	8.99	A00616-6519	Muted Violet	13.52
A00616-8053	Burnt Umber	8.99	A00616-3223	Naphthol Crimson	11.21
A00616-4529	Cad-Free Orange	17.96	A00616-3193	Naphthol Red Light	11.21
A00616-3339	Cad-Free Red Deep	17.96	A00616-4243	Naples Yellow Hue	11.21
A00616-3089	Cad-Free Red Light	18.86	A00616-2603	Ntrl Gray Value 5	8.99
A00616-3139	Cad-Free Red Medium	18.86	A00616-7384	Parchment	8.99
A00616-4189	Cad-Free Yellow Deep	13.52	A00616-2564	Payne's Gray	8.99
A00616-4069	Cad-Free Yellow Light	13.52	A00616-5143	Phthalo Blue (GS)	8.99
A00616-4089	Cad-Free Yellow Medium	13.52	A00616-5133	Phthalo Blue (RS)	11.21
A00616-5163	Cerulean Blue	13.52	A00616-7063	Phthalo Green (BS)	8.99
A00616-5173	Cerulean Blue Hue	11.21	A00616-7573	Phthalo Green (YS)	8.99
A00616-7113	Chromium Oxide Grn	11.21	A00616-6544	Prism Violet	11.21
A00616-5183	Cobalt Blue	17.95	A00616-5223	Prussian Blue Hue	11.21
A00616-6083	Cobalt Blue Hue	8.99	A00616-3163	Pyrrrole Crimson	17.95
A00616-5583	Cobalt Teal	17.95	A00616-4923	Pyrrrole Orange	17.95
A00616-5373	Cobalt Turquoise	17.95	A00616-3763	Pyrrrole Red	17.95
A00616-7013	Deep Green Permanent	11.21	A00616-5333	Quina Blue Violet	13.52
A00616-3463	Deep Magenta	13.52	A00616-4743	Quina Burnt Orange	13.52
A00616-6023	Dioxazine Purple	11.21	A00616-3513	Quina Crimson	13.52
A00616-7053	Emerald Green	11.21	A00616-6563	Quina Magenta	13.52
A00616-5243	Fluorescent Blue	11.21	A00616-3523	Quina Red	13.52
A00616-7263	Fluorescent Green	11.21	A00616-3383	Quina Red Orange	13.52
A00616-4553	Fluorescent Orange	11.21	A00616-8063	Raw Sienna	8.99
A00616-3473	Fluorescent Pink	11.21	A00616-8073	Raw Umber	8.99
A00616-3213	Fluorescent Red	11.21	A00616-3123	Red Oxide	8.99
A00616-4213	Fluorescent Yellow	11.21	A00616-7393	Sap Green Permanent	11.21
A00616-9153	Green Gold	17.95	A00616-1013	Titanium White	8.99
A00616-7713	Hkr's Grn Dp Hue Perm	8.99	A00616-8773	Trans Burnt Sienna	13.52
A00616-7353	Hooker's Grn Hue Perm	8.99	A00616-8783	Trans Burnt Umber	11.21
A00616-5343	Indanthrene Blue	13.52	A00616-1303	Trans Mixing White	8.99
A00616-4163	Indian Yellow	11.21	A00616-8163	Trans Raw Sienna	13.52
A00616-9133	Iridescent Antique Gold	11.21	A00616-8173	Trans Raw Umber	11.21
A00616-9143	Irid Bright Gold	11.21	A00616-7193	Trans Viridian Hue	11.21
A00616-9633	Irid Rich Bronze	11.21	A00616-4414	Turner's Yellow	11.21
A00616-9733	Irid Rich Copper	11.21	A00616-5233	Ultra Blue (GS)	8.99
A00616-9013	Irid Rich Gold	11.21	A00616-5273	Ultra Blue (RS)	8.99
A00616-9313	Irid Bright Silver	11.21	A00616-4343	Unbleached Titanium	8.99
A00616-9333	Irid Rich Silver	11.21	A00616-7433	Viridian Hue Perm	8.99
A00616-1133	Iridescent White	11.21	A00616-7873	Vivid Lime Green	8.99
A00616-2253	Ivory Black	8.99	A00616-3703	Vivid Red Orange	13.52
A00616-5434	Light Blue Permanent	8.99	A00616-4223	Yellow Light Hansa	8.99
A00616-6594	Light Blue Violet	8.99	A00616-4233	Yellow Medium Azo	11.21
A00616-7083	Light Green Permanent	11.21	A00616-4563	Yellow Orange Azo	11.21
A00616-3303	Light Pink	8.99	A00616-4113	Yellow Oxide	8.99

8 oz (237 ml) Bottles		
NUMBER	COLOR	EACH
A00616-3531	Alzrn Crmsn Hue Perm	\$28.74
A00616-8011	Burnt Sienna	22.45
A00616-8021	Burnt Umber	22.45
A00616-4541	Cad-Free Orange	49.39
A00616-3161	Cad-Free Red Light	49.39
A00616-3171	Cad-Free Red Medium	49.39
A00616-4611	Cad-Free Yellow Light	49.39
A00616-4621	Cad-Free Yellow Medium	49.39
A00616-6021	Dioxazine Purple	28.74
A00616-7351	Hooker's Grn Hue Perm	22.45
A00616-9141	Irid Bright Gold	28.74
A00616-9331	Irid Rich Silver	28.74
A00616-2255	Ivory Black	22.89
A00616-2041	Mars Black	22.45
A00616-3221	Naphthol Crimson	28.74
A00616-2561	Payne's Grey	22.45
A00616-5151	Phthalo Blue (GS)	22.45
A00616-7091	Phthalo Green (BS)	22.45
A00616-8081	Raw Sienna	22.45
A00616-8091	Raw Umber	22.45
A00616-1101	Titanium White	22.45
A00616-1301	Trans Mixing White	22.45
A00616-5231	Ultra Blue (GS)	22.45
A00616-4341	Unbleached Titanium	22.45
A00616-4121	Yellow Oxide	22.45

Liquitex Professional Soft Body Acrylic Sets
Mixing Set of 6 — Includes six, 59 ml (2 oz) bottles in Hookers Green Deep Hue Permanent, Ivory Black, Quinacridone Crimson, Transparent Mixing White, Ultramarine Blue (Red Shade), and Yellow Medium Azo.

For 32 oz (946 ml) jars and sets of Liquitex Soft Body Acrylic, visit DickBlick.com.



Jo Sonja's Artist Acrylic Creative Possibilities Sampler Set

Flow-formula acrylics that offer the look and feel of a traditional gouache. The colors are highly opaque, with excellent covering power and a beautiful velvet matte finish. Set contains 12 colors in 0.7 oz (20 ml) tubes, including one each of Titanium White, Yellow Light, Yellow Orange, Naphthol Red Light, Naphthol Crimson, Amethyst, Dioxazine Purple, Blue Violet, Aqua, Pine Green, Yellow Green, and Carbon Black.

NUMBER	EACH
A00722-0129	\$36.86



Jo Sonja's Artist Acrylic Iridescent Set

Add a translucent glow to your work. This set of six includes one 0.7 oz (20 ml) tube each of Iridescent Red, Iridescent Gold, Iridescent Violet, Iridescent Turquoise, Iridescent Blue, and Iridescent Green.

NUMBER	EACH
A00722-1069	\$21.18

Jo Sonja's Artist Acrylic Metallic Set

Achieve dramatic and beautiful effects. This set of six includes one 0.7 oz (20 ml) tube each of Rich Gold, Pale Gold, Rose Gold, Burnished Copper, Silver, and Pearl White.

NUMBER	EACH
A00722-1169	\$21.18



Jo Sonja's Potting Shed Background Collection Set

Rich, creamy paint is ideal for decorative painting on wood, terra cotta, tile, glass, and metal. Made from the finest-quality pigments, it's lightfast and won't fade. Set of 12, 2 oz (59 ml) bottles.

NUMBER	EACH
A00703-1009	\$32.40

HEALTH & SAFETY ICONS: ●=CL / ■=Prop 65 / ▼=CL & Prop 65
See page 644 for more information.



Golden Fluid Acrylics

The same pigment strength as Golden Heavy Body colors but with a pourable, low-viscosity formula. Wonderfully versatile, they're the perfect medium for glazing, spraying, brushing, and staining.

COLOR	1 OZ (30 ML)	EACH	4 OZ (118 ML)	EACH
Anthraquinone Blue	A00638-5911	\$9.54	A00638-5914	\$26.64
Benz Yellow Lt	A00638-4941	6.84	A00638-4944	17.27
Benz Yellow Medium	A00638-4231	6.84	A00638-4234	17.27
Bone Black	A00638-2101	6.19	A00638-2104	14.76
Burnt Sienna	A00638-8041	6.19	A00638-8044	14.76
Burnt Umber Lt	A00638-8671	6.19	A00638-8674	14.76
Cad Red Med Hue	A00638-3231	7.11	A00638-3234	18.71
Cad Ylw Med Hue	A00638-4191	7.11	A00638-4194	18.71
Carbon Black	A00638-2001	6.19	A00638-2004	14.76
Chrome Oxide Grn	A00638-7651	6.84	A00638-7654	17.27
Cobalt Blue	A00638-5181	9.98	A00638-5184	29.17
Cobalt Turquoise	A00638-5371	9.98	A00638-5374	29.17
Crlen Blue Chrom	A00638-5931	9.53	A00638-5934	26.64
Crlen Blue Dp	A00638-5161	10.88	A00638-5164	32.50
Diarylide Yellow	A00638-4491	8.63	A00638-4494	24.12
Dioxazine Purple	A00638-6021	8.63	A00638-6024	24.12
Green Gold	A00638-7001	9.53	A00638-7004	26.64
Jenkins Green	A00638-7931	9.53	A00638-7934	26.64
Nickel Azo Ylw	A00638-4991	8.63	A00638-4994	24.12
Nphthl Red Lt	A00638-3601	7.57	A00638-3604	21.34
Nphthl Red Med	A00638-3701	7.57	A00638-3704	21.34
Payne's Gray	A00638-2561	6.57	A00638-2564	16.62
Perm Green Lt	A00638-7311	7.11	A00638-7314	18.71
Perm Violet Dk	A00638-6921	9.53	A00638-6924	26.64
Phthalo Blue (GS)	A00638-7801	7.11	A00638-7804	18.71
Phthalo Blue (RS)	A00638-5921	7.11	A00638-5924	18.71
Phthalo Green (BS)	A00638-7811	7.11	A00638-7814	18.71
Phthalo Green (YS)	A00638-7901	7.11	A00638-7904	18.71
Primary Cyan	A00638-5591	6.57	A00638-5594	15.92
Primary Magenta	A00638-3041	8.63	A00638-3044	24.12
Primary Yellow	A00638-4531	6.57	A00638-4534	15.62
Pyrrrole Orange	A00638-4501	9.98	A00638-4504	29.17
Pyrrrole Red	A00638-3771	9.98	A00638-3774	29.17
Pyrrrole Red Light	A00638-3741	9.98	A00638-3744	29.17
Quina Brnt Org	A00638-4711	9.53	A00638-4784	26.64
Quina Crimson	A00638-3161	9.53	A00638-3164	26.64
Quina Magenta	A00638-6141	9.53	A00638-6144	26.64
Quina Nkle Azo Gld	A00638-9081	9.53	A00638-9084	26.64
Quina Red	A00638-3021	8.63	A00638-3024	24.12
Quina Violet	A00638-6501	8.63	A00638-6524	24.12
Raw Sienna	A00638-8051	6.19	A00638-8054	14.76
Raw Umber	A00638-8071	6.19	A00638-8074	14.76
Red Oxide	A00638-3721	6.19	A00638-3724	14.76
Teal	A00638-5071	6.84	A00638-5074	17.27
Titan Green Pale	A00638-7031	6.19	A00638-7034	14.76
Titanium Buff	A00638-8631	6.19	A00638-8634	14.76
Titanium White	A00638-1011	6.19	A00638-1014	14.76
Trans Rd Irrn Ox	A00638-3731	6.84	A00638-3734	17.27
Trans Ylw Irrn Ox	A00638-3711	6.84	A00638-3714	17.27
Turquoise	A00638-5411	7.11	A00638-5414	18.71
Ultramarine Blue	A00638-5131	6.57	A00638-5134	15.62
Ultramarine Violet	A00638-6731	7.11	A00638-6734	18.71
Vat Orange	A00638-4911	9.98	A00638-4914	29.17
Violet Oxide	A00638-6911	6.19	A00638-6914	14.76
Yellow Ochre	A00638-4041	6.19	A00638-4044	14.76
Yellow Oxide	A00638-4111	6.19	A00638-4114	14.76
Zinc White	A00638-1031	6.19	A00638-1034	14.76

Golden Fluid Acrylics Set

Professional Fluid Acrylic Set of 10 — Contains 1 oz (30 ml) bottles of Benzimidazolone Yellow Medium, Burnt Sienna, Carbon Black, Phthalo Blue (GS), Phthalo Green (BS), Pyrrrole Red, Quinacridone Magenta, Titanium White, Ultramarine Blue, and Yellow Oxide.

NUMBER	EACH
A00638-1009	\$57.61



Utrecht artists' fluid acrylics

Utrecht Artists' Fluid Acrylics
Utrecht's professional-quality Fluid Acrylics have a high-flow viscosity and offer good adhesion on a variety of surfaces. All colors are lightfast and flexible when dry.

Colors can be assorted for quantity pricing.

1 oz (30 ml) Bottles			
NUMBER	COLOR	EACH	12/EA
A01652-7201	Aquamarine	\$5.57	\$4.99
A01652-5291	Blue Gray	4.58	4.12
A01652-8041	Burnt Sienna	4.58	4.12
A01652-8051	Burnt Umber	4.58	4.12
A01652-2261	Carbon Black	4.58	4.12
A01652-5161	Cerulean Blue	4.88	4.39
A01652-7101	Chrome Green Hue	4.88	4.39
A01652-5191	Cobalt Blue Hue	4.88	4.39
A01652-4491	Diarylide Yellow	5.57	4.99
A01652-6021	Dioxazine Purple	5.57	4.99
A01652-3721	English Red Oxide	4.58	4.12
A01652-4961	Hansa Yellow Light	5.57	4.99
A01652-4981	Hansa Yellow Medium	4.88	4.39
A01652-2511	Light Gray Value 8	4.58	4.12
A01652-1091	Light Pearl	4.58	4.12
A01652-6071	Light Violet	4.88	4.39
A01652-7021	Medium Green	4.88	4.39
A01652-2521	Medium Gray Value 6	4.58	4.12
A01652-3611	Naphthol Red	4.88	4.39
A01652-3601	Naphthol Red Light	5.57	4.99
A01652-4921	Perinone Orange	7.09	6.38
A01652-3391	Permanent Alizarin Crimson	7.09	6.38
A01652-5171	Phthalo Blue	4.88	4.39
A01652-7901	Phthalo Green Yellow	6.38	5.75
A01652-4911	Quinacridone Burnt Orange	6.38	5.75
A01652-4851	Quinacridone Gold	4.88	4.39
A01652-6061	Quinacridone Violet	5.57	4.99
A01652-8061	Raw Sienna	4.58	4.12
A01652-8071	Raw Umber	4.58	4.12
A01652-3761	Red Violet	4.88	4.39
A01652-7091	Sap Green	5.57	4.99



Primary Set of 6



Essentials Set of 12

Liquitex® Professional Acrylic Gouache™

The qualities of traditional gouache combined with the benefits of an acrylic! This archival-quality paint is ideal for mixed media works, alternate surfaces, color blocks, layering, and more. The colors are highly opaque, lightfast, and vibrant. They have a creamy, fluid texture and a permanent, flat matte finish. Colors can be assorted for quantity pricing.

2 oz (59 ml) Bottles			
NUMBER	COLOR	EACH	12/EA
A00795-7203	Bright Aqua Green	\$10.21	\$9.19
A00795-6073	Brilliant Purple	10.21	9.19
A00795-8043	Burnt Sienna	10.21	9.19
A00795-8053	Burnt Umber	10.21	9.19
A00795-4543	Cadmium-Free Orange	13.98	12.58
A00795-3203	Cadmium-Free Red Deep	13.98	12.58
A00795-3093	Cadmium-Free Red Light	13.98	12.58
A00795-3103	Cadmium-Free Red Medium	13.98	12.58
A00795-4123	Cadmium-Free Yellow Deep	13.98	12.58
A00795-4133	Cadmium-Free Yellow Light	13.98	12.58
A00795-4093	Cadmium-Free Yellow Medium	13.98	12.58
A00795-5173	Cerulean Blue Hue	10.21	9.19
A00795-6023	Dioxazine Purple	10.21	9.19
A00795-7053	Emerald Green	13.98	12.58
A00795-7273	Fluorescent Green	13.98	12.58
A00795-4563	Fluorescent Orange	13.98	12.58
A00795-3723	Fluorescent Pink	13.98	12.58
A00795-3213	Fluorescent Red	13.98	12.58
A00795-6913	Fluorescent Violet	13.98	12.58
A00795-4223	Fluorescent Yellow	13.98	12.58
A00795-7123	Hooker's Green Hue Permanent	10.21	9.19
A00795-9013	Iridescent Bright Gold	10.21	9.19
A00795-9313	Iridescent Bright Silver	10.21	9.19
A00795-2253	Ivory Black	10.21	9.19
A00795-5433	Light Blue Permanent	10.21	9.19
A00795-3733	Light Pink	10.21	9.19
A00795-2043	Mars Black	10.21	9.19
A00795-3313	Medium Magenta	10.21	9.19
A00795-2543	Neutral Gray 5	10.21	9.19
A00795-2553	Neutral Gray 7	10.21	9.19
A00795-3353	Peach	10.21	9.19
A00795-5943	Phthalo Blue (GS)	10.21	9.19
A00795-6543	Prism Violet	13.98	12.58
A00795-5923	Primary Blue	10.21	9.19
A00795-3743	Primary Red	10.21	9.19
A00795-4533	Primary Yellow	10.21	9.19
A00795-5223	Prussian Blue Hue	10.21	9.19
A00795-3623	Quinacridone Magenta	13.98	12.58
A00795-8063	Raw Sienna	10.21	9.19
A00795-8073	Raw Umber	10.21	9.19
A00795-3123	Red Oxide	10.21	9.19
A00795-3083	Scarlet	13.98	12.58
A00795-5073	Sky Blue	10.21	9.19
A00795-1023	Titanium White	10.21	9.19
A00795-5403	Turquoise Deep	10.21	9.19
A00795-5233	Ultramarine Blue (RS)	10.21	9.19
A00795-1033	Unbleached Titanium	10.21	9.19
A00795-7193	Viridian Hue	13.98	12.58
A00795-7873	Vivid Lime Green	13.98	12.58
A00795-4113	Yellow Oxide	10.21	9.19

Sets			
NUMBER	DESCRIPTION	EACH	
A00795-1009	Primary Set of 6 (22 ml)	\$32.05	
A00795-1019	Primary Set of 6 (59 ml)	56.45	
A00795-1029	Fluorescent Set of 6 (59 ml)	72.85	
A00795-1039	Essential Set of 12 (22 ml)	64.07	

Vallejo Acrylic Gouache

These colors are self-leveling and have a creamy consistency and high-pigment concentration. Ideal for illustration and design, restoration, stage sets, and other flat painting, they're water-resistant, non-yellowing, and UV-resistant. Colors can be assorted for quantity pricing.

1.18 oz (35 ml) Bottles

NUMBER	COLOR	EACH	12/EA
A01694-5391	Blue Violet	\$5.54	\$4.98
A01694-9601	Bronze	5.54	4.98
A01694-8041	Burnt Sienna	5.54	4.98
A01694-8051	Burnt Umber	5.54	4.98
A01694-3541	Cadmium Red Hue	5.54	4.98
A01694-2121	Carbon Black	5.54	4.98
A01694-3741	Carnation Pink	5.54	4.98
A01694-5031	Dark Blue	5.54	4.98
A01694-3031	Dark Rose Red	5.54	4.98
A01694-4031	Dark Yellow	5.54	4.98
A01694-9011	Gold	5.54	4.98
A01694-4161	Gold Yellow	5.54	4.98

Holbein® Acryla Acrylic Gouache

Acryla Gouache is a fast-drying, acrylic-based paint that is watersoluble while wet and water-resistant when dry. It offers a matte, opaque finish, even over dark surfaces. Great for grounds and layering, it is compatible with all watersoluble media and offers excellent light resistance.

20 ml (0.68 oz) Tubes

NUMBER	COLOR	EACH	
A00811-5161	Aqua Blue	\$8.35	
A00811-5011	Ash Blue	8.35	
A00811-7011	Ash Green	8.35	
A00811-3181	Ash Rose	8.35	
A00811-4011	Ash Yellow	8.35	
A00811-8141	Beige	8.35	
A00811-5101	Blue Green	8.35	
A00811-5391	Blue Violet	8.35	
A00811-8041	Burnt Sienna	8.35	
A00811-8051	Burnt Umber	8.35	
A00811-3151	Carmine	8.35	
A00811-5171	Cerulean Blue	8.35	
A00811-1051	Chinese White	8.35	
A00811-5181	Cobalt Blue	8.35	
A00811-7161	Cobalt Green	8.35	
A00811-3241	Coral Red	8.35	
A00811-3091	Cosmos Pink	8.35	
A00811-4021	Cream Yellow	8.35	
A00811-3161	Crimson Primary	8.35	
A00811-7041	Deep Green	8.35	
A00811-3461	Deep Magenta	8.35	
A00811-6611	Deep Violet	8.35	
A00811-4321	Deep Yellow	8.35	
A00811-7051	Emerald	8.35	
A00811-3801	Flesh	8.35	
A00811-7241	Grass Green	8.35	
A00811-7021	Green	8.35	
A00811-5451	Horizon Blue	8.35	
A00811-7031	Ice Green	8.35	
A00811-1041	Ivory White	8.35	
A00811-3901	Jaune Brilliant	8.35	
A00811-2021	Jet Black	8.35	
A00811-2031	Lamp Black	8.35	
A00811-7151	Leaf Green	8.35	
A00811-4061	Lemon Yellow Primary	8.35	
A00811-6031	Lilac	8.35	
A00811-5021	Light Blue	8.35	
A00811-7061	Light Green	8.35	
A00811-3581	Light Magenta	8.35	
A00811-3101	Light Red Burnt	8.35	
A00811-4031	Light Yellow	8.35	
A00811-3041	Magenta	8.35	
A00811-7511	Mint Green	8.35	
A00811-5911	Misty Blue	8.35	
A00811-7111	Misty Green	8.35	
A00811-4091	Mustard	8.35	
A00811-4141	Naples Yellow	8.35	
A00811-5041	Navy Blue	8.35	
A00811-2511	Neutral Gray 1	8.35	
A00811-2521	Neutral Gray 2	8.35	
A00811-2531	Neutral Gray 3	8.35	
A00811-2541	Neutral Gray 4	8.35	
A00811-7071	Olive	8.35	

1.18 oz (35 ml) Bottles

NUMBER	COLOR	EACH	12/EA
A01694-9031	Golden Ochre	\$5.54	\$4.98
A01694-4041	Ochre	5.54	4.98
A01694-7071	Olive Green	5.54	4.98
A01694-4511	Orange	5.54	4.98
A01694-3041	Magenta	5.54	4.98
A01694-7551	Permanent Green	5.54	4.98
A01694-5921	Primary Blue	5.54	4.98
A01694-4531	Primary Yellow	5.54	4.98
A01694-5221	Prussian Blue Hue	5.54	4.98
A01694-3761	Red Violet	5.54	4.98
A01694-3171	Rose Red	5.54	4.98
A01694-9331	Silver	5.54	4.98
A01694-1021	Titanium White	5.54	4.98
A01694-5111	Turquoise	5.54	4.98
A01694-5231	Ultramarine Blue	5.54	4.98
A01694-3281	Vermillion	5.54	4.98
A01694-7481	Viridian	5.54	4.98
A01694-4751	Yellow Green	5.54	4.98

20 ml (0.68 oz) Tubes

NUMBER	COLOR	EACH	
A00811-3741	Opera	\$8.35	
A00811-4511	Orange	8.35	
A00811-4831	Orange Yellow	8.35	
A00811-5921	Pale Aqua	8.35	
A00811-6041	Pale Lavender	8.35	
A00811-6051	Pale Lilac	8.35	
A00811-7231	Pale Lime	8.35	
A00811-7521	Pale Mint	8.35	
A00811-3351	Pale Peach	8.35	
A00811-3081	Pale Pink	8.35	
A00811-5211	Peacock Blue	8.35	
A00811-3061	Pink	8.35	
A00811-2091	Primary Black	8.35	
A00811-5951	Primary Cyan	8.35	
A00811-3791	Primary Magenta	8.35	
A00811-1091	Primary White	8.35	
A00811-4531	Primary Yellow	8.35	
A00811-5221	Prussian Blue	8.35	
A00811-3781	Pure Red	8.35	
A00811-8061	Raw Sienna	8.35	
A00811-8071	Raw Umber	8.35	
A00811-3761	Red Violet	8.35	
A00811-3171	Rose	8.35	
A00811-3751	Rose Violet	8.35	
A00811-7091	Sap Green	8.35	
A00811-3111	Scarlet	8.35	
A00811-8081	Sepia	8.35	
A00811-3771	Shell Pink	8.35	
A00811-5071	Sky Blue	8.35	
A00811-5931	Smalt Blue	8.35	
A00811-1021	Titanium White	8.35	
A00811-5111	Turquoise Blue	8.35	
A00811-5251	Ultramarine Deep	8.35	
A00811-5231	Ultramarine Primary	8.35	
A00811-3281	Vermillion	8.35	
A00811-6511	Violet	8.35	
A00811-3711	Viridian	8.35	
A00811-3721	Wine Red	8.35	
A00811-4041	Yellow	8.35	
A00811-4051	Yellow Ochre	8.35	
A00811-8151	Bronze	13.56	
A00811-9011	Gold	13.56	
A00811-9241	Pale Gold	13.56	
A00811-9331	Silver	13.56	
A00811-5541	Metallic Blue	13.56	
A00811-7841	Metallic Green	13.56	
A00811-3731	Metallic Red	13.56	
A00811-6911	Metallic Violet	13.56	
A00811-1031	Metallic White	13.56	
A00811-4761	Metallic Yellow	13.56	
A00811-7191	Luminous Green	13.56	
A00811-4191	Luminous Lemon	13.56	
A00811-4591	Luminous Orange	13.56	
A00811-3191	Luminous Red	13.56	

Whites and Blacks, 40 ml (1.35 oz) Tubes

NUMBER	COLOR	EACH	
A00811-1053	Chinese White	\$14.76	
A00811-2043	Jet Black	14.76	
A00811-2023	Lamp Black	14.76	
A00811-1023	Titanium White	14.76	

Primary Set of 5 — 0.68 oz (20 ml) tubes of Primary Black, Primary Cyan, Primary Magenta, Primary White, and Primary Yellow.

NUMBER	EACH	
A00811-1009	\$39.89	

BLICK® matte acrylics

Blick's matte-surface, opaque acrylics are waterbased, quick-drying, and permanent yet non-toxic and safe for everyday use. Formulated with the highest-quality pigments in an exceptional range of colors, they're extremely affordable. They pour readily and consistently, apply smoothly, cover well, and can be applied to almost any surface — including paper, wood, fabric, ceramic, glass, metal, and some plastics. Perfect for decorative painting and stenciling, they also blend extremely well, making them ideal for glazing, antiquing, and faux finish techniques. Colors can be assorted for quantity pricing.

2 oz (60 ml) Bottles

NUMBER	COLOR	EACH	12/EA	24/EA
A00727-7453	Amethyst			
A00727-5163	Aqua			
A00727-8143	Beige			
A00727-2023	Black			
A00727-5103	Blue Green Light			
A00727-5113	Blue Green Med			
A00727-5123	Blue Green Deep			
A00727-5023	Blue Light			
A00727-5033	Blue Medium			
A00727-5463	Blue Deep			
A00727-5823	Blue Red Light			
A00727-5833	Blue Red Medium			
A00727-5813	Blue Red Deep			
A00727-5373	Blue Violet Light			
A00727-5383	Blue Violet Medium			
A00727-5393	Blue Violet Deep			
A00727-8003	Brown			
A00727-3043	Brilliant Magenta			
A00727-3143	Burgundy			
A00727-9503	Burnished Copper			
A00727-7483	Celadon			
A00727-5043	Dark Blue Light			
A00727-5053	Dark Blue Medium			
A00727-5063	Dark Blue Deep			
A00727-7033	Dark Green Light			
A00727-7053	Dark Green Medium			
A00727-7063	Dark Green Deep			
A00727-9023	Gold Metallic			
A00727-7753	Green Blue Light			
A00727-7763	Green Blue Medium			
A00727-7773	Green Blue Deep			
A00727-7013	Green Light			
A00727-7023	Green Medium			
A00727-7043	Green Deep			
A00727-2503	Nimbus Gray			
A00727-1583	Off White			
A00727-4513	Orange Light			
A00727-4523	Orange Medium			
A00727-4533	Orange Deep			
A00727-9263	Pale Gold			
A00727-1093	Pearl White			
A00727-9333	Pewter			
A00727-3063	Pink Light			
A00727-3073	Pink Medium			
A00727-3083	Pink Deep			
A00727-6413	Purple Madder			

Utrecht studio series™ oils



Utrecht® Studio Series™ Oils

Be bold with color — without worrying about the cost! Utrecht Studio Series Oils are available in large tubes that are a good value and a great introductory choice for students or anyone new to oil painting. These medium-bodied oils offer great consistency and workability along with dependable lightfastness. Handcrafted at Utrecht's mill in Brooklyn, New York, these paints maintain their consistency, quality, and performance from batch to batch and year to year. Colors can be assorted for quantity pricing.

6.75 oz (200 ml) Tubes			
NUMBER	COLOR	EACH	12/EA
A02121-3065	Alizarin Crimson	\$19.95	\$17.96
A02121-8045	Burnt Sienna	13.29	11.96
A02121-8055	Burnt Umber	13.29	11.96
A02121-4545	Cadmium Orange Hue	19.95	17.96
A02121-3545	Cadmium Red Hue	13.29	11.96
A02121-4255	Cadmium Yellow Hue	13.29	11.96
A02121-5175	Cerulean Blue Hue	13.29	11.96
A02121-6025	Dioxazine Purple	13.29	11.96
A02121-3255	Indian Red	13.29	11.96
A02121-2255	Ivory Black	13.29	11.96
A02121-4145	Naples Yellow Hue	13.29	11.96
A02121-2565	Payne's Gray	13.29	11.96
A02121-5925	Primary Blue (Phthalo)	13.29	11.96
A02121-4535	Primary Yellow (Zinc)	13.29	11.96
A02121-5225	Prussian Blue	13.29	11.96
A02121-7585	Prussian Green	13.29	11.96
A02121-8065	Raw Sienna	13.29	11.96
A02121-8075	Raw Umber	13.29	11.96
A02121-7105	Sap Green Hue	13.29	11.96
A02121-1015	Titanium White	13.29	11.96
A02121-5235	Ultramarine Blue	13.29	11.96
A02121-7515	Viridian Green	13.29	11.96
A02121-7345	Yellow Green	13.29	11.96
A02121-4045	Yellow Ochre	13.29	11.96

Gamblin® 1980 Oils

This line of 48 colors offers artists a better student-grade paint, defined by true color and real value. Gamblin 1980 Oils are true to the pigment, true to historic working properties, and remain true thanks to excellent ratings for lightfastness. They are made at Gamblin's wind-powered factory in Portland, Oregon.

5.07 oz (150 ml) Tubes

NUMBER	COLOR	EACH
A01587-3064	Alizarin Crimson	\$18.06
A01587-3154	Blush	18.06
A01587-8044	Burnt Sienna	15.11
A01587-8054	Burnt Umber	15.11
A01587-7214	Cadmium Green	29.13
A01587-4534	Cadmium Orange	29.13
A01587-3094	Cadmium Red Light	29.13
A01587-3104	Cadmium Red Medium	29.13
A01587-4134	Cadmium Yellow Light	29.13
A01587-4094	Cadmium Yellow Med	29.13
A01587-5194	Cerulean Blue	29.13
A01587-7894	Chromium Oxide Green	18.06
A01587-5184	Cobalt Blue	29.13
A01587-6524	Cobalt Violet	29.13

Van Gogh® Oil Colors

Van Gogh Oil Colors have been developed for artists who are searching for quality and value. Colors can be assorted for quantity pricing.

1.35 oz (40 ml) Tubes

NUMBER	COLOR	EACH	12/EA
A00476-3070	Alizarin Crimson	\$5.45	\$4.90
A00476-4910	Azo Orange	5.45	4.90
A00476-3500	Azo Red Deep	5.45	4.90
A00476-3510	Azo Red Light	5.45	4.90
A00476-3520	Azo Red Medium	5.45	4.90
A00476-4320	Azo Yellow Deep	5.45	4.90
A00476-4060	Azo Yellow Lemon	5.45	4.90
A00476-4010	Azo Yellow Light	5.45	4.90
A00476-4020	Azo Yellow Medium	5.45	4.90
A00476-8020	Burnt Sienna	5.45	4.90
A00476-8030	Burnt Umber	5.45	4.90
A00476-4540	Cadmium Orange	11.18	10.06
A00476-3210	Cadmium Red Deep	11.18	10.06
A00476-3080	Cadmium Red Light	11.18	10.06
A00476-3100	Cadmium Red Medium	11.18	10.06
A00476-4130	Cadmium Yellow Deep	11.18	10.06
A00476-4350	Cadmium Yellow Light	11.18	10.06
A00476-4090	Cadmium Yellow Med	11.18	10.06
A00476-3150	Carmine	11.18	10.06
A00476-5160	Cerulean Blue	11.18	10.06
A00476-5140	Cerulean Blue Phthalo	5.45	4.90
A00476-7640	Chromium Oxide Green	11.18	10.06
A00476-5180	Cobalt Blue	11.18	10.06
A00476-5200	Cobalt Blue Ultra	5.45	4.90
A00476-7040	Emerald Green	5.45	4.90
A00476-7180	Fir Green	11.18	10.06

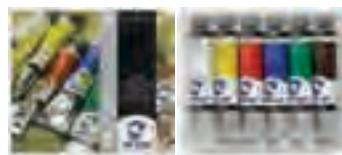

1.35 oz (40 ml) Tubes

NUMBER	COLOR	EACH	12/EA
A00476-3240	Indian Red	\$11.18	\$10.06
A00476-4150	Indian Yellow	11.18	10.06
A00476-2240	Ivory Black	5.45	4.90
A00476-2010	Lamp Black	5.45	4.90
A00476-3120	Light Oxide Red	5.45	4.90
A00476-3700	Mdr Lake Dp-Aliz Crim	5.45	4.90
A00476-3730	Madder Lake Light	5.45	4.90
A00476-6630	Mars Violet	11.18	10.06
A00476-4510	Naples Yellow Deep	5.45	4.90
A00476-4780	Naples Yellow Light	5.45	4.90
A00476-4170	Naples Yellow Red	5.45	4.90
A00476-2550	Payne's Gray	11.18	10.06
A00476-7230	Permanent Olive Green	11.18	10.06
A00476-7550	Permanent Green Deep	11.18	10.06
A00476-7790	Permanent Green Med	5.45	4.90
A00476-7520	Permanent Red	11.18	10.06
A00476-3740	Permanent Red Violet	11.18	10.06
A00476-3260	Permanent Rose	5.45	4.90
A00476-5130	Phthalo Blue	5.45	4.90
A00476-7800	Phthalo Green	5.45	4.90
A00476-5960	Phthalo Turquoise Blue	11.18	10.06
A00476-5220	Prussian Blue	5.45	4.90
A00476-3260	Quinacridone Rose	5.45	4.90
A00476-8080	Raw Sienna	5.45	4.90
A00476-8090	Raw Umber	5.45	4.90
A00476-7090	Sap Green	5.45	4.90
A00476-5900	Sevres Blue	5.45	4.90
A00476-7120	Terre Verte	5.45	4.90
A00476-1100	Titanium White	5.45	4.90
A00476-1130	Titan White-Linseed Oil	5.45	4.90
A00476-3130	Trans Oxide Red	11.18	10.06
A00476-4110	Trans Oxide Yellow	11.18	10.06
A00476-5110	Turquoise Blue	5.45	4.90
A00476-5250	Ultramarine Deep	5.45	4.90
A00476-8300	Vandyke Brown	5.45	4.90
A00476-3270	Vermilion	11.18	10.06
A00476-6510	Violet	5.45	4.90
A00476-7930	Viridian	11.18	10.06
A00476-4030	Yellow Ochre	5.45	4.90
A00476-4740	Yellowish Green	5.45	4.90
A00476-1030	Zinc White	5.45	4.90

Set of 6 — 0.68 oz (20 ml) tubes of Titanium White, Azo Yellow Light, Azo Red Medium, Cobalt Blue Ultramarine, Permanent Green Deep, and Burnt Umber.

NUMBER	EACH	6/EA
A00476-0069	\$22.64	\$20.38

Set of 10 — 0.68 oz (20 ml) tubes of Titanium White, Azo Yellow Light, Azo Red Medium, Cobalt Blue Ultramarine, Permanent Green Deep, Burnt Umber, Azo Yellow Deep, Quinacridone Rose, Cerulean Blue Phthalo, and Ivory Black.

NUMBER	EACH	6/EA
A00476-0109	\$42.76	\$38.48

5.07 oz (150 ml) Tubes

NUMBER	COLOR	EACH
A01587-4984	Transparent Yellow Oxide	\$18.06
A01587-5114	Turquoise	18.06
A01587-5234	Ultramarine Blue	18.06
A01587-6734	Ultramarine Violet	18.06
A01587-8314	Van Dyke Brown	15.11
A01587-3134	Venetian Red	15.11
A01587-7194	Viridian	29.13
A01587-4044	Yellow Ochre	15.11
A01587-1024	Titanium White	15.11
A01587-2044	Mars Black	15.11
A01587-2254	Ivory Black	15.11



Introductory Set of 9 — 1.25 oz (37 ml) tubes. For set contents, visit DickBlick.com.

NUMBER	EACH
A01587-1019	\$55.55

HEALTH & SAFETY ICONS: ●=CL / ■=Prop 65 / ▼=CL & Prop 65 See page 644 for more information.

BLICK® studio oil colors



Made in England using quality ingredients, Blick Studio Oils offer great performance at an affordable Blick price. Available in a broad range of 50 colors, they have a buttery texture, strong pigmentation, and a great consistency. Stroke for stroke, they're one of the best student-grade paints you'll find.

Colors can be assorted for quantity pricing.

COLOR	1.35 OZ (40 ML)	7.6 OZ (200 ML)
Blue Gray	A01557-5860	—
Brilliant Rose	A01557-3170	—
Buff Titanium	A01557-1123	A01557-1124
Burnt Sienna	A01557-8043	A01557-8044
Burnt Umber	A01557-8053	A01557-8054
Cadmium Orange Hue	A01557-4543	A01557-4544
Cadmium Red Dp Hue	A01557-3323	A01557-3324
Cadmium Red Hue	A01557-3543	A01557-3544
Cadmium Red Lt Hue	A01557-3093	A01557-3094
Cadmium Yellow Hue	A01557-4353	A01557-4354
Cadmium Ylw Dp Hue	A01557-4283	A01557-4284
Cadmium Ylw Pale Hue	A01557-4303	A01557-4304
Cerulean Blue Hue	A01557-5173	A01557-5174
Cobalt Blue Hue	A01557-5193	A01557-5194
Cobalt Violet Hue	A01557-6573	A01557-6574
Crimson Alizarin	A01557-3063	A01557-3064
Dioxazine Purple	A01557-6023	A01557-6024
Emerald Green	A01557-7050	—
Flake White Hue	A01557-1040	A01557-1045
Ultramarine Blue	A01557-5133	A01557-5134
Hooker's Green	A01557-7123	—
Ivory Black	A01557-2253	A01557-2254
Lamp Black	A01557-2023	A01557-2024
Lemon Yellow	A01557-4063	A01557-4064
Light Blue	A01557-5020	A01557-5025
Mixing White	A01557-1303	A01557-1304
Naphthol Crimson	A01557-3223	—
Naples Yellow	A01557-4143	A01557-4144
Payne's Gray	A01557-2563	A01557-2564
Permanent Blue	A01557-5780	—
Permanent Light Green	A01557-7313	A01557-7314
Phthalo Blue	A01557-5163	A01557-5164
Phthalo Green	A01557-7803	A01557-7804
Rosy Beige	A01557-3713	A01557-3714
Primary Magenta	A01557-3700	A01557-3705
Primary Yellow	A01557-4530	—
Prussian Blue	A01557-5223	A01557-5224
Raw Sienna	A01557-8063	A01557-8064
Raw Umber	A01557-8073	A01557-8074
Rose Madder	A01557-3500	A01557-3505
Sap Green	A01557-7093	A01557-7094
Scarlet Lake	A01557-9940	—
Terre Verte Hue	A01557-7133	—
Titanium White	A01557-1023	A01557-1024
Van Dyke Brown Hue	A01557-8313	—
Violet Gray	A01557-6680	—
Viridian	A01557-7933	A01557-7934
Yellow Green	A01557-4753	A01557-4754
Yellow Ochre	A01557-4043	A01557-4044
Zinc White	A01557-1033	A01557-1034

EACH	6/EA	EACH	6/EA
\$4.40	\$3.95	\$11.89	\$10.70



Color swatches are full strength and 50% tint.

Lemon Yellow	Cadmium Ylw Pale Hue	Cadmium Yellow Hue	Cadmium Ylw Dp Hue	Primary Yellow	Naples Yellow	Rosy Beige	Cadmium Orange Hue
Cadmium Red Lt Hue	Brilliant Rose	Rose Madder	Scarlet Lake	Cadmium Red Hue	Cadmium Red Dp Hue	Naphthol Crimson	
Crimson Alizarin	Cobalt Violet Hue	Dioxazine Purple	Primary Magenta	Violet Grey	Permanent Blue	Ultramarine Blue	
Cobalt Blue Hue	Phthalo Blue	Prussian Blue	Light Blue	Cerulean Blue Hue	Emerald Green	Viridian	
Yellow Green	Permanent Light Green	Hooker's Green	Phthalo Green	Sap Green	Terre Verte Hue	Yellow Ochre	
Raw Sienna	Burnt Sienna	Burnt Umber	Raw Umber	Van Dyke Brown Hue	Payne's Gray	Ivory Black	
Lamp Black	Brilliant Grey	Flake White	Mixing White	Titanium White	Zinc White	Buff Titanium	

A-C Blick® Studio Oil Color Sets

A Starter Set of 10 — Titanium White, Lemon Yellow, Cadmium Red Hue, Ultramarine Blue, Viridian Hue, Crimson Alizarin, Yellow Ochre, Burnt Sienna, Raw Umber, and Ivory Black. 1.35 oz (40 ml) tubes.

NUMBER	EACH
A01557-1039	\$45.25

B Basic Set of 12 — Lemon Yellow, Cadmium Yellow Hue, Cadmium Red Hue, Crimson Alizarin, Ultramarine Blue, Cerulean Blue Hue, Sap Green, Yellow Ochre, Burnt Sienna, Burnt Umber, Ivory Black, and Titanium White. 0.71 oz (21 ml) tubes.

NUMBER	EACH
A01557-1209	\$26.78



C Basic Set of 24 — All of the colors in the Basic Set of 12 plus Cadmium Yellow Pale Hue, Cadmium Orange Hue, Primary Magenta, Dioxazine Purple, Phthalo Blue, Light Blue, Permanent Green Light, Emerald Green Hue, Raw Sienna, Raw Umber, Zinc White, and Buff Titanium. 0.71 oz (21 ml) tubes.

NUMBER	EACH
A01557-2419	\$43.45



WARNING! Products marked with a Prop 65 symbol (■ or ▼) can expose you to chemicals, including cadmium, which are known to the State of California to cause cancer and birth defects or other reproductive harm. For more information, visit P65Warnings.ca.gov.

Talens Art Creation Oil Sets

This paint is made with high-quality pigments and vegetable oil, resulting in intense colors, smooth brushstrokes, and clean mixes. Apply it as-is for a pasty texture, or thin it. It dries slowly and retains its volume and bright color after it's dry. 0.41 oz (12 ml) tubes.

Set of 12 — Titanium White, Lemon Yellow, Yellow, Scarlet, Carmine, Ultramarine, Sevres Blue, Permanent Green, Yellow Ochre, Burnt Sienna, Burnt Umber, and Ivory Black.

NUMBER	EACH
A02134-1129	\$11.19

Set of 24 — The colors in the Set of 12, plus Zinc White, Orange, Vermilion, Cobalt Blue (Ultramarine), Phthalo Blue, Prussian Blue, Emerald Green, Viridian, Olive Green, Raw Sienna, Raw Umber, and Payne's Grey,

NUMBER	EACH
A02134-1249	\$21.52



M. Graham Solvent Free Oil Color Set with FREE Mediums

Includes five 1.25 oz (37 ml) tubes of M. Graham Artists' Oil plus FREE 2 oz bottles of Walnut Oil and Walnut Alkyd Medium — non-toxic alternatives to solvent-based mediums. Colors include Azo Yellow, Naphthol Red, Ultramarine Blue, Phthalocyanine Green, and Titanium White.

NUMBER	EACH
A01573-1059	\$59.07



Daler-Rowney Graduate Oil Set

Contains 10 colors in 1.3 oz (38 ml) tubes: Titanium White, Lemon Yellow, Cadmium Red Hue, Crimson, Ultramarine, Sap Green, Yellow Ochre, Burnt Umber, Burnt Sienna, and Ivory Black. Contents may vary.

NUMBER	EACH
A02103-1009	\$44.31

Maimeri Classico Oil Colors

Sargent Art Oil Color Set

The set contains 12, 0.41 oz (12 ml) colors including Ivory Black, Prussian Blue, Viridian Green, Sap Green, Cobalt Blue, Yellow Ochre, Crimson Lake, Scarlet Lake, Lemon Yellow Tint, Cadmium Yellow Deep, Burnt Sienna, and Titanium White.

Contains 12, 0.41 oz (12 ml) colors including Ivory Black, Prussian Blue, Viridian Green, Sap Green, Cobalt Blue, Yellow Ochre, Crimson Lake, Scarlet Lake, Lemon Yellow Tint, Cadmium Yellow Deep, Burnt Sienna, and Titanium White.

NUMBER	EACH	12/EA
A02118-1012	\$8.78	\$7.90



NUMBER	COLOR	EACH
A01558-4944	Brilliant Yellow Deep	\$19.39
A01558-4924	Brilliant Yellow Light	19.39
A01588-8014	Brown Stil de Grain	18.29
A01558-8044	Burnt Sienna	19.39
A01558-8054	Burnt Umber	19.39
A01558-8834	Cassel Earth	19.39
A01558-5164	Cerulean Blue	38.88
A01558-7374	Chrom Oxide Green	19.39
A01558-7924	Cinnabar Green Deep	19.39
A01558-7914	Cinnabar Green Light	19.39
A01558-7904	Cinnabar Green Yellowish	19.39
A01558-5384	Cobalt Blue Dark Hue	19.39
A01558-5914	Cobalt Blue Light Hue	19.39
A01558-6574	Cobalt Violet Hue	19.39
A01558-9164	Deep Gold	19.39
A01558-7054	Emerald Green	38.88
A01558-4094	Golden Ochre	19.39
A01558-7944	Green Earth	19.39
A01558-7464	Green Lake	19.39
A01558-4724	Indian Yellow Hue	19.39
A01558-2254	Ivory Black	19.39
A01558-5924	Kings Blue Light	38.88
A01558-9124	Light Gold	19.39
A01558-2044	Mars Black	\$19.39
A01558-3364	Mars Red	19.39
A01558-4524	Naples Yellow Deep	19.39
A01558-4794	Naples Yellow Light	38.88
A01558-4784	Naples Yellow Red Hue	19.39
A01558-2564	Payne's Grey	19.39
A01558-3164	Perm Carmine	19.39
A01558-7084	Perm Green Deep	19.39
A01558-7374	Perm Green Light	19.39
A01558-3814	Perm Red Deep	19.39
A01558-3764	Perm Red Light	19.39
A01558-3374	Perm Red Orange	19.39
A01558-6914	Perm Violet Bluish	19.39
A01558-6724	Perm Violet Reddish	19.39
A01558-4874	Perm Yellow Deep	19.39
A01558-4394	Perm Yellow Lemon	19.39
A01558-4384	Perm Yellow Light	19.39
A01558-3734	Permanent Madder Deep	19.39
A01558-5764	Phthalo Blue Green	19.39
A01558-7804	Phthalo Green	19.39
A01558-3224	Pozzuoli Earth	19.39
A01558-5954	Primary Blue Cyan	19.39
A01558-3744	Primary Red Magenta	19.39
A01558-4534	Primary Yellow	19.39
A01558-5224	Prussian Blue	19.39
A01558-3274	Quinacridone Red	38.88
A01558-3794	Quinacridone Rose Lt	19.39
A01558-8064	Raw Sienna	19.39
A01558-8074	Raw Umber	19.39
A01558-7094	Sap Green	19.39
A01558-9334	Silver	19.39
A01558-5074	Sky Blue	19.39
A01558-1044	Super Rapid White	19.39
A01558-1024	Titanium White	19.39
A01558-1334	Titan-Zinc White	19.39

NUMBER	COLOR	EACH
A01558-5114	Turquoise Blue	\$19.39
A01558-5254	Ultramarine Deep	19.39
A01558-5304	Ultramarine Light	19.39
A01558-8314	Van Dyke Brown	19.39
A01558-3134	Venetian Red	19.39
A01558-3494	Vermilion Deep Hue	19.39
A01558-3484	Vermilion Light Hue	19.39
A01558-4044	Yellow Ochre	19.39
A01558-4834	Yellow Ochre Light	19.39
A01558-1034	Zinc White	19.39



Marshall's Photo Oil Sets

Introduce students to the art of hand-coloring photographs using the time-honored Marshall System. These sets includes everything beginners need to get started. Colors in the sets may vary. **Learn To Color Set** — Contains nine photo oil colors, P.M. Solution (for thinning), and cotton balls and toothpicks for applying.

NUMBER	EACH	6/EA
A00426-1009	\$48.16	\$43.34

Hobby Set — This all-inclusive set contains fifteen colors, Marlene Medium (for removing undesired color), and various application tools.

NUMBER	EACH	6/EA
A00426-1019	\$102.79	\$92.51

Richeson Oils Shiva Series Basic Set of 6

Includes one 1.25 oz (37 ml) tube each of Hansa Yellow Light, Ivory Black, Naphthol Red Medium, Phthalo Green (Blue Shade), Ultramarine Blue Deep, and Titanium White.

NUMBER	EACH	12/EA
A00416-1009	\$50.84	\$45.76

Maimeri Classico Oil Sets

NUMBER	COLOR	EACH
A01558-5114	Turquoise Blue	\$19.39
A01558-5254	Ultramarine Deep	19.39
A01558-5304	Ultramarine Light	19.39
A01558-8314	Van Dyke Brown	19.39
A01558-3134	Venetian Red	19.39
A01558-3494	Vermilion Deep Hue	19.39
A01558-3484	Vermilion Light Hue	19.39
A01558-4044	Yellow Ochre	19.39
A01558-4834	Yellow Ochre Light	19.39
A01558-1034	Zinc White	19.39



Maimeri Classico Oil Sets

Bright, lively colors with overall harmony in the palette, Classico Oil Colors are made with modern, non-toxic, non-polluting pigments that improve lightfastness. All colors may be intermixed in any ratio or proportion, without limits. For more sets and set contents, visit DickBlick.com.

NUMBER	DESCRIPTION	EACH
A01558-1049	Intro Set of 8	\$54.77
A01558-1069	Intro Set of 9	86.73
A01558-1059	Painting Set	89.88



Winsor & Newton Winton Oil Color Starter Set

This set contains 10, 1.25 oz (37 ml) tubes, including one each of Cadmium Yellow Pale Hue, Cadmium Red Deep Hue, French Ultramarine, Phthalo Blue, Viridian Hue, Sap Green, Yellow Ochre, Burnt Sienna, Ivory Black, and Titanium White.

NUMBER	EACH
A00430-0109	\$58.89



Winsor & Newton Winton Oil Color 10-Tube Set

Offers a wider palette than the Introductory Set featured above. The 10 colors include Cadmium Lemon Hue, Cadmium Red Deep Hue, Phthalo Blue, French Ultramarine, Viridian Hue, Permanent Green, Yellow Ochre, Burnt Sienna, Ivory Black, and Titanium White in 0.7 oz (21 ml) tubes.

NUMBER	EACH
A00430-1109	\$40.75



Winsor & Newton Winton Oil Color Studio Oil Set

This set contains eight 0.7 oz (21 ml) tubes including Cadmium Yellow Pale Hue, Cadmium Red Deep Hue, French Ultramarine, Phthalo Blue, Viridian Hue, Yellow Ochre, Burnt Sienna, and Burnt Umber, plus one 2 oz (60 ml) tube of Titanium White, one 2.5 oz (75 ml) glass bottle of Liquin, two hog bristle brushes, a color chart, and a step-by-step guide to painting a landscape.

NUMBER	EACH
A00441-1009	\$64.99

WINSOR & NEWTON

Winsor & Newton Winton Oil Colors

Winton Oils contain modern hue pigments that produce an extremely close likeness in color to more expensive natural pigments and have an excellent permanence rating. Intermixable with other oils.

COLOR	1.25 OZ (37 ML) TUBES	EACH	6.75 OZ (200 ML) TUBES	EACH
Azo Brown	A00430-8583	\$5.62	A00430-8584	\$15.32
Azo Yellow Green	A00430-4453	5.62	A00430-4454	15.32
Burnt Sienna	A00430-8043	5.62	A00430-8044	15.32
Burnt Umber	A00430-8053	5.62	A00430-8054	15.32
Cadmium Lemon	A00430-4183	12.37	A00430-4184	27.36
Cadmium Orange	A00430-4533	12.37	—	—
Cadmium Orange Hue	A00430-4543	5.62	A00430-4544	15.32
Cadmium Red Hue	A00430-3543	5.62	A00430-3544	15.32
Cadmium Red Light	A00430-3093	12.37	A00430-3094	27.36
Cadmium Red Medium	A00430-3103	12.37	A00430-3104	27.36
Cadmium Red Dp Hue	A00430-3323	5.62	A00430-3324	15.32
Cadmium Scarlet Hue	A00430-3563	5.62	A00430-3564	15.32
Cadmium Yellow Hue	A00430-4353	5.62	A00430-4354	15.32
Cadmium Yellow Light	A00430-4073	12.37	A00430-4074	27.36
Cadmium Yellow Medium	A00430-4093	12.37	A00430-4094	27.36
Cadmium Ylw Dp Hue	A00430-4283	5.62	A00430-4284	15.32
Cadmium Ylw Pale Hue	A00430-4253	5.62	A00430-4254	15.32
Cerulean Blue	A00430-5163	12.37	A00430-5164	27.36
Cerulean Blue Hue	A00430-5173	5.62	A00430-5174	15.32
Cobalt Blue	A00430-5183	12.37	A00430-5184	27.36
Cobalt Blue Hue	A00430-5193	5.62	A00430-5194	15.32
Cobalt Violet Hue	A00430-6573	5.62	A00430-6574	15.32
Dark Verdigris	A00430-7123	5.62	A00430-7124	15.32
Dioxazine Blue	A00430-5203	5.62	A00430-5204	15.32
Dioxazine Purple	A00430-6023	5.62	A00430-6024	15.32
French Ultramarine	A00430-5273	5.62	A00430-5274	15.32
Indian Red	A00430-3253	5.62	A00430-3254	15.32
Ivory Black	A00430-2253	5.62	A00430-2254	15.32
Lamp Black	A00430-2023	5.62	A00430-2024	15.32
Lemon Yellow Hue	A00430-4513	5.62	A00430-4514	15.32
Light Red	A00430-3013	5.62	A00430-3014	15.32
Magenta	A00430-3043	5.62	A00430-3044	15.32
Naples Yellow Hue	A00430-4243	5.62	A00430-4244	15.32
Oxide of Chromium	A00430-7373	5.62	A00430-7374	15.32
Pale Rose Blush	A00430-3843	5.62	A00430-3844	15.32
Payne's Gray	A00430-2563	5.62	A00430-2564	15.32
Perm Alizarin Crimson	A00430-3063	5.62	A00430-3064	15.32
Perm Green Light	A00430-7313	5.62	A00430-7314	15.32
Perm Rose	A00430-3263	5.62	A00430-3264	15.32
Phthalo Blue	A00430-5143	5.62	A00430-5144	15.32
Phthalo Deep Grn	A00430-7823	5.62	A00430-7824	15.32
Phthalo Yellow Grn	A00430-4463	5.62	A00430-4464	15.32
Prussian Blue	A00430-5223	5.62	A00430-5224	15.32
Quinacridone Deep Pink	A00430-3273	5.62	A00430-3274	15.32
Raw Sienna	A00430-8063	5.62	A00430-8064	15.32
Raw Umber	A00430-8073	5.62	A00430-8074	15.32
Sap Green	A00430-7093	5.62	A00430-7094	15.32
Soft Mixing White	A00430-1039	5.62	A00430-1049	15.32
Terre Verte	A00430-7133	5.62	A00430-7134	15.32
Titanium White	A00430-1013	5.62	A00430-1014	15.32
Van Dyke Brown	A00430-8313	5.62	A00430-8314	15.32
Vermilion Hue	A00430-3423	5.62	A00430-3424	15.32
Viridian Hue	A00430-7193	5.62	A00430-7194	15.32
Yellow Ochre	A00430-4043	5.62	A00430-4044	15.32
Zinc White	A00430-1033	5.62	A00430-1034	15.32

Winsor & Newton Winton Oil Color Introductory Set

High-quality yet economical, these oils possess good covering power and tinting strength. This set includes six 0.7 oz (21 ml) tubes of Cadmium Yellow Pale Hue, Permanent Alizarin Crimson, French Ultramarine, Viridian Hue, Yellow Ochre, and Burnt Umber.

NUMBER	EACH
A00430-1009	\$22.95



BOB ROSS®

Bob Ross® Oil Colors

Fine artist-quality colors exclusively formulated for the Ross method. Ground in purest alkali-refined linseed oil for permanence and color intensity. Colors can be assorted for quantity pricing.

COLOR	1.25 oz (37 ml)	6.8 oz (200 ml)
Alizarin Crimson	A00455-3063	A00455-3064
Bright Red	A00455-3073	A00455-3074
Cadmium Yellow	A00455-4203	A00455-4204
Dark Sienna	A00455-8373	A00455-8374
Indian Yellow	A00455-4163	A00455-4164
Midnight Black	A00455-2183	A00455-2184
Mountain Mix	A00455-1000	A00455-1003
Phthalo Blue	A00455-5143	A00455-5144
Phthalo Green	A00455-7063	A00455-7064
Prussian Blue	A00455-5223	A00455-5224
Sap Green	A00455-7093	A00455-7094
Titanium White	A00455-1013	A00455-1014
Van Dyke Brown	A00455-8313	A00455-8314
Yellow Ochre	A00455-4043	A00455-4044

NUMBER	EACH	6/EA	3/EA
A00455-1016	\$7.49	\$6.74	\$19.82 \$17.84

Floral Soft Oil Colors

NUMBER	COLOR	EACH	6/EA
A00455-3163	Alizarin Crimson	\$9.43	\$8.49
A00455-4533	Cadmium Orange	13.27	11.94
A00455-3093	Cadmium Red Light	13.27	11.94
A00455-3103	Cadmium Red Medium	13.27	11.94
A00455-4073	Cadmium Yellow Light	13.27	11.94
A00455-3713	Flower Pink	9.43	8.49
A00455-2253	Ivory Black	7.49	6.74
A00455-6063	Mauve	9.43	8.49
A00455-7193	Sap Green	9.43	8.49
A00455-3043	Soft Magenta	9.43	8.49
A00455-1323	Titanium White	7.49	6.74
A00455-5113	Turquoise	7.49	6.74
A00455-5233	Ultramarine Blue	7.49	6.74

NUMBER	EACH	3/EA
A00455-1324	\$15.08	\$13.58

Wildlife Soft Oil Colors — 1.25 oz (37 ml)

NUMBER	COLOR	EACH	6/EA
A00481-8043	Burnt Sienna	\$6.26	\$5.63
A00481-8053	Burnt Umber	6.26	5.63
A00481-4163	Indian Yellow	8.13	7.32
A00481-8073	Raw Umber	6.26	5.63
A00481-2023	Translucent Black	8.13	7.32
A00481-1783	Warm White	8.13	7.32
A00481-4043	Yellow Ochre	6.26	5.63

Wildlife Soft Oil Colors — 4 oz (120 ml)

NUMBER	COLOR	EACH	6/EA
A00481-2024	Liquid Acrylic Black	\$7.14	\$6.43
A00481-1014	Liquid Acrylic White	7.14	6.43

Wildlife Soft Oil Colors Glazing Medium — 4 oz (120 ml)

NUMBER	EACH	6/EA
A00481-1024	\$7.14	\$6.43



Bob Ross® Master Paint Set

Everything you need to create a beautiful mountainscape with Bob Ross. Includes eight 1.25 oz (37 ml) tubes of Bob Ross Oil Color, a 4 oz (118 ml) jar of Liquid White, four brushes, a painting knife, and a 30-minute instructional DVD. Painting surface not included.

NUMBER	EACH	6/EA
A00464-1029	\$88.12	\$79.31



Bob Ross® Basic Paint Set

The basics you need to paint with Bob Ross. Set contains five 1.25 oz (37 ml) tubes of oil color (Cadmium Yellow, Sap Green, Phthalo Blue, Alizarin Crimson, and Titanium White), plus a 4 oz (118 ml) jar of Liquid White, a #5 painting knife, and a 1" landscape brush.

NUMBER	EACH	6/EA
A00464-1009	\$58.74	\$52.87

Bob Ross® Oil Painting Mediums

Liquid Base Coats — These special slow-drying base coats have been developed to allow blending and mixing of colors on the canvas.

NUMBER	DESCRIPTION	EACH	3/EA
A00455-2005	Black, 8.4 oz (250 ml)	\$15.66	\$14.09
A00455-1905	Clear, 8.4 oz (250 ml)	15.66	14.09
A00455-1005	White, 8.4 oz (250 ml)	15.66	14.09
A00455-1026	White, 16.9 oz (500 ml)	21.03	18.93

Gessos — These waterbased primers should be applied very thinly with a foam applicator, not a brush, and allowed to dry completely before you begin painting in the Bob Ross style. 16 oz (473 ml) plastic bottles.

NUMBER	COLOR	EACH	3/EA
A00455-2006	Black	\$14.25	\$12.82
A00455-2506	Gray	14.25	12.82
A00455-1116	White	14.25	12.82



Weber® Permalba® White & Black Oil Color

An exclusive blend of Titanium and other pigments results in an outstandingly rich, creamy white (ASTM D 4236) or black (AP) oil paint that is intermixable with other brands of oils. For exceptional brilliance like no other white, try the original Permalba.

NUMBER	COLOR	EACH	6/EA
A00452-2024	Black	\$14.13	\$12.72
A00452-1004	White	14.13	12.72



A-E Bob Ross® Brushes

These are the brushes used in the demonstrations of Bob Ross oil paints — they also work well with other brands of oil and acrylic.

NUMBER	STYLE	EACH	12/EA
A05231-1004	A Size 4 Floral Fan	\$23.13	\$20.82
A05231-1106	B Size 6 Round	16.26	14.63
A05231-1112	C Size 12 Filbert	20.17	18.15
A05231-4012	D 1/2" Bright	20.17	18.15
A05231-4034	E 3/4" Bright	25.66	23.09



John Howard Sanden™ Brush Sets

Hog Bristle (except where noted).
Student Set — 10 Filberts (two each Size 2, 4, 6, and 8; one each Size 10 and 12); three Fans in Size 2, 4, and 6; three red sable Brights in Size 2, 4, and 6; one red sable Round in Size 10; and three red sable Cat's Tongue in Size 2, 4, and 6.

NUMBER	EACH	3/EA
A05251-0019	\$215.57	\$193.99

Beginner Set — Eight Filberts (two each Size 2 and 6; one each Size 4, 8, 10, and 12), and one Size 10 red sable Round.

NUMBER	EACH	3/EA
A05251-0009	\$120.81	\$109.69

Atelier Sable Set — 21 pure red sable brushes: two Rounds in Size 6 and 8; five Cat's Tongue in Size 2, 4, 6, 8, and 10; 14 Brights (two each of Size 2, 4, 6, 8, 10, 18, and 20).

NUMBER	EACH	3/EA
A05251-0199	\$323.00	\$293.92

Sennelier® Rive Gauche Oil Colors

Designed to dry faster and resist yellowing better, Rive Gauche is a great addition to your palette. Made with safflower oil, these paints are luminous and opaque. They have a high pigment concentration, which allows for strong covering power and cleaner mixes. For more info and additional colors, visit DickBlick.com.

6.76 oz (200 ml) Tubes

NUMBER	COLOR	EACH
A00849-3714	Alizarin Crimson	\$15.60
A00849-5914	Anthraquinone Blue	15.60
A00849-5864	Blue Grey	15.60
A00849-4754	Bright Yellow Green	15.60
A00849-8714	Burnt Sienna	15.60
A00849-8054	Burnt Umber	15.60
A00849-3324	Cad Red Deep Hue	15.60
A00849-3194	Cadmium Red Lt Hue	15.60
A00849-4644	Cadmium Red Orange Hue	15.60
A00849-4284	Cad Yellow Deep Hue	15.60
A00849-4194	Cad Ylw Lemon Hue	15.60
A00849-4134	Cad Yellow Lt Hue	15.60
A00849-4364	Cad Yellow Med Hue	15.60
A00849-3154	Carmine Red	15.60
A00849-5174	Cerulean Blue Hue	15.60
A00849-7914	Chromium Oxide Green	15.60
A00849-5194	Cobalt Blue Hue	15.60
A00849-7674	Cobalt Green Dp Hue	15.60
A00849-6024	Dioxazine Purple	15.60
A00849-7274	Forest Green	15.60
A00849-5274	French Ultramarine Blue	15.60
A00849-9004	Golden Green	15.60
A00849-7214	Green Earth	15.60
A00849-6004	Helios Purple	15.60
A00849-7124	Hooker's Green	15.60
A00849-3254	Indian Red	15.60
A00849-4164	Indian Yellow	15.60
A00849-2254	Ivory Black	15.60
A00849-4064	Lemon Yellow	15.60
A00849-2044	Mars Black	15.60
A00849-8004	Modigliani Ochre	15.60
A00849-3604	Naphthol Red	15.60
A00849-4144	Naples Yellow	15.60
A00849-4514	Orange	15.60
A00849-2564	Payne's Grey	15.60
A00849-7084	Phthalo Green (BS)	15.60
A00849-7344	Phthalo Green (YS)	15.60
A00849-5114	Phthalo Turquoise	15.60
A00849-5924	Primary Blue	15.60
A00849-3744	Primary Red	15.60
A00849-4534	Primary Yellow	15.60
A00849-5224	Prussian Blue	15.60
A00849-3764	Pyrrrole Red	15.60
A00849-3794	Quinacridone Pink	15.60
A00849-8064	Raw Sienna	15.60
A00849-8074	Raw Umber	15.60
A00849-3754	Red Violet	15.60
A00849-7094	Sap Green	15.60
A00849-1024	Titanium White	15.60
A00849-5304	Ultramarine Blue Lt	15.60
A00849-8314	Van Dyck Brown	15.60
A00849-3134	Venetian Red	15.60
A00849-3284	Vermilion	15.60
A00849-3234	Warm Grey	15.60
A00849-4044	Yellow Ochre	15.60
A00849-1034	Zinc White	15.60

Set of 8 — 1.35 oz (40 ml) tubes of Titanium White, Cadmium Yellow Lemon Hue, Cadmium Medium Hue, Cadmium Red Light Hue, Alizarin Crimson, Prussian Blue, French Ultramarine Blue, and Ivory Black.

NUMBER	EACH
A00849-1009	\$52.41

Set of 10 — 0.71 oz (21 ml) tubes of Titanium White, Primary Yellow, Primary Red, Ultramarine Blue Light, Primary Blue, Sap Green, Burnt Sienna, Ivory Black, Vermilion Red, and Cadmium Yellow Deep Hue.

NUMBER	EACH
A00849-1019	\$45.21

Daler-Rowney® Georgian Oil Colors

A high-quality line of colors at an economical price, Georgian Oils can be used with a knife or brush to achieve a variety of effects.

7.6 oz (225 ml) Tubes

NUMBER	COLOR	EACH
A00485-5865	Blue Gray	\$17.20
A00485-3725	Brilliant Rose	17.20
A00485-8625	Buff Titanium	17.20
A00485-8045	Burnt Sienna	17.20
A00485-8055	Burnt Umber	17.20
A00485-4535	Cadmium Orange Hue	17.20
A00485-3335	Cadmium Red	17.20
A00485-3205	Cadmium Red Deep Hue	17.20
A00485-3095	Cadmium Red Light Hue	17.20
A00485-4205	Cadmium Yellow	17.20
A00485-4125	Cadmium Yellow Deep Hue	17.20
A00485-4305	Cadmium Yellow Pale Hue	17.20
A00485-5015	Coeruleum Blue	17.20
A00485-5185	Cobalt Blue	17.20
A00485-6525	Cobalt Violet Hue	17.20
A00485-3065	Crimson Alizarin	17.20
A00485-7055	Emerald Green Hue	17.20
A00485-3845	Peach Pink	17.20
A00485-5235	French Ultramarine	17.20
A00485-7125	Hooker's Green	17.20
A00485-3255	Indian Red	17.20
A00485-2255	Ivory Black	17.20
A00485-2025	Lamp Black	17.20
A00485-4065	Lemon Yellow	17.20
A00485-5025	Light Blue	17.20
A00485-1305	Mixing White	17.20
A00485-4145	Naples Yellow	17.20
A00485-2565	Payne's Gray	17.20
A00485-5785	Permanent Blue	17.20
A00485-7315	Permanent Green Light	17.20
A00485-3735	Permanent Mauve	17.20
A00485-7805	Phthalo Green	17.20
A00485-5165	Primary Cyan	17.20
A00485-3495	Primary Magenta	17.20
A00485-4155	Primary Yellow	17.20
A00485-5225	Prussian Blue	17.20
A00485-4675	Pyrrrole Orange	17.20
A00485-3225	Pyrrrole Red	17.20
A00485-8065	Raw Sienna	17.20
A00485-8075	Raw Umber	17.20
A00485-3505	Rose Madder	17.20
A00485-7095	Sap Green	17.20
A00485-3085	Scarlet Lake	17.20
A00485-7135	Terre Verte Hue	17.20
A00485-1020	Titanium White	17.20
A00485-1345	Underpainting White	17.20
A00485-8315	Vandyke Brown Hue	17.20
A00485-3135	Venetian Red	17.20
A00485-3285	Vermilion	17.20
A00485-6685	Violet Gray	17.20
A00485-7105	Viridian Hue	17.20
A00485-4755	Yellow Green	17.20
A00485-4045	Yellow Ochre	17.20
A00485-1035	Zinc White	17.20

For more sizes, visit DickBlick.com.



Starter Set of 6 — 0.74 oz (22 ml) tubes of Georgian Oil Color, including Titanium White, Cadmium Yellow, Cadmium Red, French Ultramarine, Viridian Hue, and Burnt Umber.

NUMBER	EACH
A00485-4009	\$23.74

Grumbacher® Academy Oil Colors

A favorite of students, these paints offer a generous pigment load and excellent tinting strength. The full range has an ASTM 1 rating for lightfastness. Colors can be assorted for quantity pricing.

1.25 oz (37 ml) Tubes

NUMBER	COLOR	EACH	12/EA
A00418-3063	Alizarin Crimson	\$5.54	\$4.99
A00418-8043	Burnt Sienna	5.54	4.99
A00418-8053	Burnt Umber	5.54	4.99
A00418-4543	Cadmium Orange Hue	5.54	4.99
A00418-3320	Cad Red Dp Hue	5.54	4.99
A00418-3183	Cadmium Red Lt Hue	5.54	4.99
A00418-3233	Cadmium Red Med Hue	5.54	4.99
A00418-4280	Cad Ylw Dp Hue	5.54	4.99
A00418-4130	Cad Ylw Lt Hue	5.54	4.99
A00418-4193	Cadmium Ylw Med Hue	5.54	4.99
A00418-4253	Cadmium Ylw Pale Hue	5.54	4.99
A00418-5173	Cerulean Blue Hue	5.54	4.99
A00418-7650	Chrm Oxd Green	5.54	4.99
A00418-5193	Cobalt Blue Hue	5.54	4.99

Utrecht artists' oils



Utrecht® Cadmium-Free Artists' Oil Colors

Utrecht is the first to develop a range of cadmium-free oil colors. The eight vibrant colors offer improved color richness, increased brilliance, and balanced color spacing. The organic pigments don't sacrifice the professional strength that artists need. They retain the same buttery texture, outstanding lightfastness, and high performance of their cadmium counterparts.

Colors can be assorted for quantity pricing.

NUMBER	COLOR	EACH	6/EA
A02122-4173	Cadmium-Free Lemon Yellow	\$24.03	\$21.63
A02122-4193	Cadmium-Free Yellow Light	19.81	17.83
A02122-4203	Cadmium-Free Yellow Medium	19.81	17.83
A02122-4293	Cadmium-Free Yellow Deep	19.81	17.83
A02122-4533	Cadmium-Free Orange	19.81	17.83
A02122-3313	Cadmium-Free Red Light	24.03	21.63
A02122-3333	Cadmium-Free Red Medium	24.03	21.63
A02122-3343	Cadmium-Free Red Deep	24.03	21.63

Utrecht® Artists' Oil Colors

Utrecht paints are handcrafted in our Brooklyn factory using the finest pigments and a milling process artists have loved for more than 50 years. Utrecht Artists' Oil Colors are prized for their brilliant color, buttery texture, and outstanding lightfastness.

Don't be misled by their affordability — they're comparable in quality to leading oil paint brands that cost significantly more.

Colors can be assorted for quantity pricing.



Complete Painting Set

Utrecht® Artists' Oil Color Sets

Complete Painting Set — Includes nine 1.25 oz (37 ml) colors (Naples Yellow Light, Cadmium Red Hue, Burnt Sienna, Hansa Yellow Light, Alizarin Crimson, Phthalo Blue, Phthalo Green, Yellow Ochre, and Ivory Black), a 5 oz (150 ml) tube of Titanium White, three hog bristle brushes (Size 4 Round, Size 8 Flat, and Size 6 Filbert), a palette knife, and a 9" x 12" paper palette pad.

NUMBER	EACH
A02123-1009 ▼	\$123.60

Basic Color Set — Titanium White, Cadmium Yellow Hue, Cadmium Red Hue, Brilliant Blue, Brilliant Green, and Ivory Black in 1.25 oz (37 ml) tubes.

NUMBER	EACH
A02123-1019	\$43.31

Color Theory Set — Contains five 1.25 oz (37 ml) colors including Titanium White, Zinc Yellow Hue, Quinacridone Red, Phthalo Blue, and Ivory Black, plus a color mixing guide.

NUMBER	EACH
A02123-1029	\$49.67

Landscape Set — Includes Titanium White, Cadmium Yellow Lemon, Yellow Ochre, Quinacridone Red, Venetian Red, Viridian, Yellow Green, Ultramarine Blue, and Payne's Gray in 1.25 oz (37 ml) tubes.

NUMBER	EACH
A02123-1049 ▼	\$85.95

Portrait Set — Contains nine 1.25 oz (37 ml) colors including Titanium White, Naples Yellow Light, Yellow Ochre, Cadmium Red Light, Alizarin Crimson, Chromium Oxide Green, Burnt Sienna, Ultramarine Blue, and Payne's Gray.

NUMBER	EACH
A02123-1059 ▼	\$74.39

COLOR	1.25 OZ (37 ML)	EACH	6/EA	5 OZ (150 ML)	EACH	6/EA
Alizarin Crimson	A02122-3063	\$10.31	\$9.28	A02122-3065	\$27.26	\$24.54
Aureolin Cobalt Yellow	A02122-4273	28.07	25.26	—	—	—
Brilliant Blue	A02122-5063	8.71	7.84	A02122-5065	21.61	19.45
Brilliant Green	A02122-7253	8.71	7.84	A02122-7255	21.61	19.45
Burnt Sienna	A02122-8043	8.71	7.84	A02122-8045	21.61	19.45
Burnt Umber	A02122-8053	8.71	7.84	A02122-8055	21.61	19.45
Cadmium Orange Pure	A02122-4553	19.81	17.83	A02122-4555	50.98	45.85
Cadmium Orange Hue	A02122-4543	10.31	9.28	A02122-4545	27.26	24.54
Cadmium Red Deep Pure	A02122-3323	24.03	21.63	—	—	—
Cadmium Red Hue	A02122-3543	10.31	9.28	A02122-3545	27.26	24.54
Cadmium Red Light Pure	A02122-3093	24.03	21.63	A02122-3095	62.76	56.49
Cadmium Red Med Pure	A02122-3113	24.03	21.63	A02122-3115	62.76	56.49
Cadmium Ylw Deep Pure	A02122-4283	19.81	17.83	—	—	—
Cadmium Yellow Hue	A02122-4253	8.71	7.84	A02122-4355	21.61	19.45
Cadmium Ylw Lemon Pure	A02122-4183	24.03	21.63	A02122-4185	62.76	56.49
Cadmium Ylw Light Pure	A02122-4073	19.81	17.83	A02122-4075	50.98	45.85
Cadmium Ylw Med Pure	A02122-4093	19.81	17.83	A02122-4095	50.98	45.85
Cerulean Blue Chromium	A02122-5143	24.03	21.63	—	—	—
Cerulean Blue Hue	A02122-5173	10.31	9.28	A02122-5175	27.26	24.54
Cerulean Blue Pure	A02122-5153	24.03	21.63	—	—	—
Chromium Oxide Green	A02122-7113	10.31	9.28	—	—	—
Cobalt Blue Pure	A02122-5183	24.03	21.63	A02122-5185	62.76	56.49
Cobalt Blue Hue	A02122-5193	8.71	7.84	A02122-5195	21.61	19.45
Cobalt Green Pure	A02122-7053	24.03	21.63	—	—	—
Cobalt Turquoise Pure	A02122-5313	28.07	25.26	—	—	—
Cool Grey N	A02122-2533	10.31	9.28	—	—	—
Davey's Gray	A02122-2503	10.31	9.28	—	—	—
Delft Blue	A02122-5213	10.31	9.28	—	—	—
Dioxazine Purple	A02122-6023	10.31	9.28	A02122-6025	27.26	24.54
French Ultramarine	A02122-5273	10.31	9.28	—	—	—
Green Earth Hue	A02122-7213	8.71	7.84	A02122-7215	—	—
Greenish Umber	A02122-8913	8.71	7.84	—	—	—
Hansa Yellow Light	A02122-4963	8.71	7.84	A02122-4965	—	—
Indian Yellow	A02122-4163	10.31	9.28	—	—	—
Indigo	A02122-5203	10.31	9.28	—	—	—
Ivory Black	A02122-2253	8.71	7.84	A02122-2255	—	—
Manganese Violet	A02122-6403	10.31	9.28	A02122-6405	27.26	24.54
Mars Black	A02122-2043	8.71	7.84	—	—	—
Mars Ivory Black	A02122-2053	8.71	7.84	A02122-2055	—	—
Mars Yellow	A02122-4383	10.31	9.28	—	—	—
Naphthol Red Light	A02122-3193	10.31	9.28	A02122-3195	—	—
Naples Yellow Deep	A02122-4523	10.31	9.28	—	—	—
Naples Yellow Hue	A02122-4243	8.71	7.84	A02122-4245	—	—
Naples Yellow Light	A02122-4793	8.71	7.84	A02122-4795	21.61	19.45
Neutral Grey N	A02122-2523	10.31	9.28	—	—	—
Olive Green	A02122-7073	10.31	9.28	—	—	—
Payne's Gray	A02122-2563	8.71	7.84	A02122-2565	21.61	19.45
Perm Alizarin Crimson	A02122-3393	19.81	17.83	—	—	—
Permanent Alizarin Purple	A02122-6433	19.81	17.83	—	—	—
Permanent Green	A02122-7983	10.31	9.28	A02122-7985	27.26	24.54
Permanent Green Light	A02122-7433	10.31	9.28	—	—	—
Permanent Sap Green	A02122-7393	10.31	9.28	—	—	—
Phthalo Blue (BS)	A02122-5163	8.71	7.84	A02122-5165	21.61	19.45
Phthalo Green (BS)	A02122-7803	8.71	7.84	A02122-7805	21.61	19.45
Prussian Blue	A02122-5223	8.71	7.84	—	—	—
Prussian Green	A02122-7583	10.31	9.28	—	—	—
Quinacridone Red	A02122-3273	19.99	17.83	—	—	—
Quinacridone Rose	A02122-3793	19.81	17.83	—	—	—
Quinacridone Violet	A02122-6063	19.81	17.83	—	—	—
Raw Sienna	A02122-8063	8.71	7.84	A02122-8065	—	—
Raw Umber	A02122-8073	8.71	7.84	A02122-8075	21.61	19.45
Rose Madder Hue	A02122-3503	8.71	7.84	—	—	—
Sap Green Hue	A02122-7103	10.31	9.28	A02122-7105	27.26	24.54
Spectrum Black N	A02122-2223	10.31	9.28	—	—	—
Terra Rosa Hue	A02122-3743	8.71	7.84	—	—	—
Titanium White	A02122-1013	8.71	7.84	A02122-1015	21.61	19.45
Titanium Yellow N	A02122-5003	8.71	7.84	A02122-5005	—	—
Transparent Gold Ochre	A02122-8393	10.31	9.28	—	—	—
Transparent Red Oxide	A02122-3123	8.71	7.84	—	—	—
Ultramarine Blue	A02122-5133	8.71	7.84	A02122-5135	—	—
Ultramarine Violet	A02122-6643	10.31	9.28	—	—	—
Unbleached Titanium	A02122-1023	8.71	7.84	A02122-1005	—	—
Utrecht White	A02122-1003	8.71	7.84	A02122-1007	—	—
Van Dyke Brown	A02122-8313	8.71	7.84	—	—	—
Venetian Red	A02122-3133	8.71	7.84	A02122-7505	—	—
Viridian	A02122-7503	19.81	17.83	—	—	—
Vivid White N	A02122-1513	10.31	9.28	—	—	—
Warm Blush N	A02122-3713	10.31	9.28	—	—	—
Warm Grey N	A02122-2323	10.31	9.28	—	—	—
Warm White N	A02122-1783	8.71	7.84	—	—	—
Yellow Green	A02122-7343	10.31	9.28	—	—	—
Yellow Ochre	A02122-4303	8.71	7.84	A02122-4305	21.61	19.45

16 oz (473 ml) Tubes	NUMBER	COLOR	EACH
	A02122-2256	Ivory Black	\$54.69
	A02122-1016	Titanium White	54.69

Quart (946 ml) Jars	NUMBER	COLOR	EACH
	A02122-1017	Titanium White	\$100.68
	A02122-1007	Utrecht White	100.68

HEALTH & SAFETY ICONS: ●=CL / ■=Prop 65 / ▼=CL & Prop 65
See page 644 for more information.

BLICK® artists' oils



Professional quality at an affordable Blick price! A luminous satin finish, extreme responsiveness, and dense, buttery feel are hallmarks of the Blick Artists' Oil Color line. Formulated using the finest hand-ground pigments and the purest binding agents, 34 of the 60 colors in the line are made from a single pigment, including real cadmiums and cobalts, not hues. Choose from a wide spectrum of rich, vivid colors. All are backed by our 100% satisfaction guarantee. Colors can be assorted for quantity pricing.



1.35 oz (40 ml) Tubes	NUMBER	COLOR	EACH	6/EA
	A01595-3713	Alizarin Crimson	\$15.27	\$13.73
	A01595-3723	Blush Tint	11.03	9.93
	A01595-8043	Burnt Sienna	8.77	7.90
	A01595-8053	Burnt Umber	8.77	7.90
	A01595-3203 ▼	Cadmium Red Deep	34.03	30.63
	A01595-3093 ▼	Cadmium Red Light	34.03	30.63
	A01595-3233 ▼	Cadmium Red Medium	34.03	30.63
	A01595-3223 ▼	Cadmium Red Orange	34.03	30.63
	A01595-4123 ▼	Cadmium Yellow Deep	34.03	30.63
	A01595-4173 ▼	Cadmium Yellow Lemon	34.03	30.63
	A01595-4183 ▼	Cadmium Yellow Light	34.03	30.63
	A01595-4093 ▼	Cadmium Yellow Med	34.03	30.63
	A01595-4223 ▼	Cadmium Yellow Orange	34.03	30.63
	A01595-5173	Cerulean Blue	39.24	35.34
	A01595-7923	Chromium Green Deep	15.27	13.73
	A01595-7113	Chromium Oxide Green	15.27	13.73
	A01595-5183	Cobalt Blue	39.24	35.34
	A01595-7913	Cobalt Green Light	39.24	35.34
	A01595-5373	Cobalt Turquoise	39.24	35.34
	A01595-3403	English Red	8.77	7.90
	A01595-5273	French Ultra Blue	11.03	9.93
	A01595-7213	Green Earth	8.77	7.90
	A01595-3253	Indian Red	11.03	9.93
	A01595-4163	Indian Yellow	11.03	9.93
	A01595-5203	Indigo	11.03	9.93
	A01595-2253	Ivory Black	8.77	7.90
	A01595-4063	Lemon Yellow	11.03	9.93
	A01595-4833	Light Yellow Ochre	8.77	7.90
	A01595-3043	Magenta	34.03	30.63
	A01595-6623	Manganese Violet	15.27	13.73
	A01595-2043	Mars Black	8.77	7.90
	A01595-4143	Naples Yellow	11.03	9.93

1.35 oz (40 ml) Tubes	NUMBER	COLOR	EACH	6/EA
	A01595-4013	Naples Yellow Light	\$11.03	\$9.93
	A01595-4193	Naples Yellow Warm	11.03	9.93
	A01595-7073	Olive Green	15.27	13.73
	A01595-2563	Payne's Gray	11.03	9.93
	A01595-3393	Perm Alizarin Crimson	15.27	13.73
	A01595-7553	Permanent Green	15.27	13.73
	A01595-3263	Permanent Rose	11.03	9.93
	A01595-8833 ▼	Permanent Tuscan Earth	18.99	17.10
	A01595-4753 ▼	Permanent Yellow Green	18.99	17.10
	A01595-5163	Phthalo Blue	15.27	13.73
	A01595-5223	Prussian Blue	11.03	9.93
	A01595-3623	Quinacridone Magenta	18.99	17.10
	A01595-8073	Raw Umber	8.77	7.90
	A01595-8063	Raw Sienna	8.77	7.90
	A01595-3733	Red Ochre Tint	8.77	7.90
	A01595-3753	Rose Madder Light	15.27	13.73
	A01595-7093	Sap Green	11.03	9.93
	A01595-8083	Sepia	8.77	7.90
	A01595-1023	Titanium White	8.77	7.90
	A01595-5253	Turquoise Light	15.27	13.73
	A01595-3763	Ultramarine Rose	11.03	9.93
	A01595-6733	Ultramarine Violet	11.03	9.93
	A01595-3133	Venetian Red	8.77	7.90
	A01595-6503	Violet Pastel	11.03	9.93
	A01595-7483	Viridian	18.99	17.10

GAMBLIN



Gamblin Artist's Oil Colors

Handcrafted at Gamblin's wind-powered factory in Portland, Oregon, each color is made with quality pigments and alkali-refined linseed oil for greater permanence and less yellowing over time.

5 oz (150 ml) Tubes		
NUMBER	COLOR	EACH
A00401-3064	Alizarin Crimson	\$45.56
A00401-3054	Alizarin Permanent	45.56
A00401-8184	Asphaltum	45.56
A00401-2344	Black Spinel	63.40
A00401-8484	Brown Pink	32.99
A00401-8044	Burnt Sienna	26.19
A00401-8054	Burnt Umber	26.19
A00401-4314	Cadmium Chartreuse	63.40
A00401-7214	Cadmium Green	63.40
A00401-4184	Cadmium Lemon	63.40
A00401-4534	Cadmium Orange	63.40
A00401-4914	Cadmium Orange Deep	63.40
A00401-3094	Cadmium Red Light	75.79
A00401-3104	Cadmium Red Medium	75.79
A00401-3204	Cadmium Red Deep	75.79
A00401-4074	Cadmium Yellow Light	63.40
A00401-4094	Cadmium Yellow Medium	63.40
A00401-4124	Cadmium Yellow Deep	63.40
A00401-5164	Cerulean Blue	92.30
A00401-5174	Cerulean Blue Hue	32.99
A00401-2144	Chromatic Black	32.99
A00401-7654	Chromium Oxide Green	45.56
A00401-5184	Cobalt Blue	75.79
A00401-7164	Cobalt Green	63.40
A00401-5084	Cobalt Teal	63.40

5 oz (150 ml) Tubes		
NUMBER	COLOR	EACH
A00401-6524	Cobalt Violet	\$92.30
A00401-1874	Cool White	26.19
A00401-9504	Copper	63.40
A00401-6024	Dioxazine Purple	32.99
A00401-7054	Emerald Green	32.99
A00401-1274	Flake White Replacement	26.19
A00401-9704	Green Gold	63.40
A00401-9034	Gold Ochre	32.99
A00401-4704	Hansa Yellow Light	45.56
A00401-4714	Hansa Yellow Medium	45.56
A00401-4974	Hansa Yellow Deep	45.56
A00401-5344	Indanthrene Blue	45.56
A00401-3254	Indian Red	26.19
A00401-4164	Indian Yellow	45.56
A00401-2254	Ivory Black	26.19
A00401-5334	Manganese Blue Hue	32.99
A00401-6624	Manganese Violet	45.56
A00401-2044	Mars Black	26.19
A00401-4944	Naphthol Scarlet	32.99
A00401-3874	Naples Orange	32.99
A00401-4244	Naples Yellow Hue	32.99
A00401-3604	Naphthol Red	32.99
A00401-4834	Nickel Titanate Yellow	45.56
A00401-7074	Olive Green	32.99
A00401-9244	Pale Gold	63.40
A00401-2564	Payne's Gray	32.99
A00401-7314	Permanent Green Light	32.99
A00401-4934	Permanent Orange	45.56
A00401-3724	Perylene Red	45.56
A00401-5144	Phthalo Blue	32.99
A00401-5424	Phthalo Turquoise	32.99
A00401-7064	Phthalo Green	32.99
A00401-7564	Phthalo Emerald	32.99
A00401-2644	Portland Cool Gray	32.99
A00401-2634	Portland Gray Light	32.99
A00401-2624	Portland Gray Medium	32.99
A00401-2614	Portland Gray Deep	32.99

5 oz (150 ml) Tubes		
NUMBER	COLOR	EACH
A00401-2654	Portland Warm Gray	\$32.99
A00401-5224	Prussian Blue	32.99
A00401-1044	Quick Dry White	26.19
A00401-3624	Quinacridone Magenta	45.56
A00401-3274	Quinacridone Red	45.56
A00401-6514	Quinacridone Violet	45.56
A00401-5194	Radiant Blue	32.99
A00401-7014	Radiant Green	32.99
A00401-4064	Radiant Lemon	32.99
A00401-3044	Radiant Magenta	32.99
A00401-3014	Radiant Red	32.99
A00401-5124	Radiant Turquoise	32.99
A00401-6694	Radiant Violet	32.99
A00401-1024	Radiant White	32.99
A00401-4014	Radiant Yellow	32.99
A00401-8064	Raw Sienna	26.19
A00401-8074	Raw Umber	26.19
A00401-9264	Rich Gold	63.40
A00401-7094	Sap Green	32.99
A00401-9304	Silver	63.40
A00401-7134	Terre Verte	32.99
A00401-8624	Burnt Umber	26.19
A00401-1114	Titanium White	26.19
A00401-1334	Titanium-Zinc White	26.19
A00401-4964	Transparent Orange	45.56
A00401-4954	Transparent Earth Orange	45.56
A00401-3734	Transparent Earth Red	45.56
A00401-4984	Transparent Earth Yellow	45.56
A00401-5234	Ultramarine Blue	32.99
A00401-6644	Ultramarine Violet	32.99
A00401-8314	Van Dyke Brown	26.19
A00401-4924	Venetian Red	26.19
A00401-7104	Viridian	63.40
A00401-1884	Warm White	26.19
A00401-4044	Yellow Ochre	26.19
A00401-1034	Zinc White	26.19

GRUMBACHER



Grumbacher Pre-Tested Oil Colors

These archival-quality oils offer optimal color development, high chroma, superior tinting strength, excellent adhesion, and outstanding working properties. Colors can be assorted for quantity pricing.

1.25 oz (37 ml) Tubes		
NUMBER	COLOR	EACH
A00448-3063	Alizarin Crimson	\$13.97 \$12.57
A00448-3713	Aliz Crimson Golden	13.97 12.57
A00448-4273	Aureolin	26.13 23.51
A00448-8213	Brown Madder	13.97 12.57
A00448-8483	Brown Pink	10.99 9.92
A00448-8123	Burnt Sienna Deep	8.39 7.56
A00448-8043	Burnt Sienna	8.39 7.56
A00448-8053	Burnt Umber	8.39 7.56
A00448-4723	Cadmium Orange	18.35 16.53
A00448-3723	Cadmium Red Deep	23.09 20.80
A00448-3733	Cadmium Red Light	23.09 20.80
A00448-3743	Cadmium Red Medium	23.09 20.80
A00448-3753	Cadmium Red	23.09 20.80
A00448-4623	Cadmium Yellow Deep	18.35 16.53
A00448-4633	Cadmium Yellow Light	18.35 16.53
A00448-4643	Cadmium Yellow Medium	18.35 16.53
A00448-4713	Cadmium Orange Medium	18.35 16.53
A00448-4653	Cadmium Yellow Pale	18.35 16.53
A00448-7213	Cadmium Green Light	23.09 20.80
A00448-5913	Cerulean Blue Genuine	26.13 23.51
A00448-5173	Cerulean Blue Hue	10.99 9.92
A00448-7113	Chrom Oxide Green	13.97 12.57

1.25 oz (37 ml) Tubes		
NUMBER	COLOR	EACH
A00448-5183	Cobalt Blue	\$23.09 \$20.80
A00448-3763	Cobalt Rose	26.13 23.51
A00448-5903	Cobalt Titanate Blue	18.35 16.53
A00448-7903	Cobalt Titanate Green	18.35 16.53
A00448-5373	Cobalt Turquoise	18.35 16.53
A00448-6573	Cobalt Violet Hue	18.35 16.53
A00448-2613	Davy's Gray	10.99 9.92
A00448-4493	Diarylide Yellow	13.97 12.57
A00448-6023	Dioxazine Purple	13.97 12.57
A00448-3863	Flesh Hue	10.99 9.92
A00448-5273	French Ultra Blue	10.99 9.92
A00448-9033	Gold Ochre Hue	8.39 7.56
A00448-7913	Green Earth Hue	8.39 7.56
A00448-9063	Green Gold Hue	10.99 9.92
A00448-7953	Greenish Umber	8.39 7.56
A00448-3773	Grum Red (Naphthol)	13.97 12.57
A00448-5343	Indanthrene Blue	18.35 16.53
A00448-3253	Indian Red	8.39 7.56
A00448-5203	Indigo Blue	13.97 12.57
A00448-2253	Ivory Black	8.39 7.56
A00448-2023	Lamp Black	8.39 7.56
A00448-2043	Mars Black	10.99 9.92
A00448-4933	Mono Azo Orange	13.97 12.57
A00448-4243	Naples Yellow Hue	10.99 9.92
A00448-4823	Nickel Titanate Yellow	18.35 16.53
A00448-7073	Olive Green	13.97 12.57
A00448-2563	Payne's Gray	10.99 9.92
A00448-5923	Perm Blue (Ultra)	10.99 9.92
A00448-7963	Perm Green Bright	10.99 9.92
A00448-7083	Permanent Green Light	18.31 16.47
A00448-5223	Prussian Blue	10.99 9.92
A00448-4823	Prussian Green	10.99 9.92
A00448-4913	Quinacridone Orange	18.35 16.53
A00448-3273	Quinacridone Red	13.97 12.57
A00448-8063	Raw Sienna	8.39 7.56
A00448-8073	Raw Umber	8.39 7.56
A00448-3793	Rose Madder Hue	10.99 9.92

1.25 oz (37 ml) Tubes		
NUMBER	COLOR	EACH
A00448-7093	Sap Green	\$13.97 \$12.57
A00448-3703	Terra Rosa Hue	10.99 9.92
A00448-5143	Thalo Blue	13.97 12.57
A00448-7183	Thalo Green (BS)	13.97 12.57
A00448-7563	Thalo Green Yellow	13.97 12.57
A00448-3783	Thalo Red Rose	18.35 16.53
A00448-7573	Thalo Yellow Green	10.99 9.92
A00448-6553	Thio Violet	10.99 9.92
A00448-1013	Titanium White	8.39 7.56
A00448-1323	Titanium White Soft	8.39 7.56
A00448-3123	Transparent Red Oxide	8.39 7.56
A00448-4923	Transparent Yellow Ox	8.39 7.56
A00448-6643	Ultra Violet	10.99 9.92
A00448-5253	Ultramarine Blue Deep	10.99 9.92
A00448-1023	Unbleached Titan Wht	8.39 7.56
A00448-8313	Van Dyke Brown	8.39 7.56
A00448-3133	Venetian Red	8.39 7.56
A00448-7103	Viridian	23.09 20.80
A00448-4043	Yellow Ochre	8.39 7.56
A00448-1033	Zinc White	8.39 7.56
A00448-4433	Zinc Yellow Hue	10.99 9.92

5 oz (150 ml) Tubes		
NUMBER	COLOR	EACH
A00448-2254	Ivory Black	\$21.36 \$19.20
A00448-1014	Titanium White	21.36 19.20
A00448-1324	Titanium White Soft	23.35 20.99
A00448-1034	Zinc White	21.36 19.20

10-Color Sampler Set — Sample size 0.81 oz (24 ml) tubes of Burnt Sienna, Burnt Umber, Cadmium Red Light, Cadmium Yellow Medium, Ivory Black, Thalo Blue, Thalo Green (Blue Shade), Thio Violet, Titanium White, and Yellow Ochre.



Winsor & Newton Artists' Oil Colors

Winsor & Newton Artists' Oil Colors exemplify the marriage of art and science that has been the company's core philosophy for more than 175 years.

1.25 oz (37 ml) Tubes		
NUMBER	COLOR	EACH
A00461-3063	Alizarin Crimson	\$13.78
A00461-4613	Bismuth Yellow	25.79
A00461-2093	Blue Black	10.31
A00461-3073	Bright Red	10.31
A00461-9603	Bronze	13.78
A00461-8213	Brown Madder	10.31
A00461-8223	Brown Ochre	10.31
A00461-8043	Burnt Sienna	10.31
A00461-8053	Burnt Umber	10.31
A00461-7613	Cad Free Green Pale	25.79
A00461-4193	Cad Free Lemon	25.79
A00461-4543	Cad Free Orange	25.79
A00461-3323	Cad Free Red	25.79
A00461-3213	Cad Free Red Dp	25.79
A00461-3553	Cad Free Scarlet	25.79
A00461-4113	Cad Free Yellow	25.79
A00461-4133	Cad Free Yellow Dp	25.79
A00461-4313	Cad Free Yellow Pale	25.79
A00461-7623	Cadmium Green Pale	25.79
A00461-4183	Cadmium Lemon	25.79
A00461-4533	Cadmium Orange	25.79
A00461-3333	Cadmium Red	25.79
A00461-3203	Cadmium Red Deep	25.79
A00461-3563	Cadmium Scarlet	25.79
A00461-4203	Cadmium Yellow	25.79
A00461-4123	Cadmium Yellow Deep	25.79
A00461-4303	Cadmium Yellow Pale	25.79
A00461-5163	Cerulean Blue	25.79
A00461-2613	Charcoal Gray	10.31
A00461-7913	Chromite	10.31
A00461-4913	Chromium Yellow Hue	10.31
A00461-5183	Cobalt Blue	25.79
A00461-5383	Cobalt Blue Deep	35.22
A00461-7173	Cobalt Chromite	25.79
A00461-7163	Cobalt Green	35.22
A00461-5373	Cobalt Turquoise	35.22
A00461-7923	Cobalt Turquoise Light	25.79
A00461-6523	Cobalt Violet	35.22
A00461-9503	Copper	13.78
A00461-2623	Davy's Gray	13.78
A00461-1113	Flake White Hue	10.31
A00461-5273	French Ultramarine	13.78
A00461-9003	Gold	13.78
A00461-9033	Gold Ochre	10.31
A00461-7113	Green Gold	13.78
A00461-5343	Indanthrene Blue	25.79
A00461-3253	Indian Red	13.78
A00461-4163	Indian Yellow	13.78
A00461-4173	Indian Yellow Deep	13.78
A00461-5203	Indigo	13.77
A00461-1063	Iridescent White	10.31
A00461-2253	Ivory Black	10.31
A00461-3903	Jaune Brilliant	10.31
A00461-2023	Lamp Black	10.31
A00461-4513	Lemon Yellow Hue	25.79
A00461-3013	Light Red	10.31
A00461-3043	Magenta	13.78
A00461-5333	Manganese Blue Hue	10.31
A00461-2043	Mars Black	13.78
A00461-6693	Mars Violet Deep	13.78
A00461-6423	Mauve Blue Shade	10.31
A00461-4143	Naples Yellow	10.31
A00461-4523	Naples Yellow Deep	13.78
A00461-4793	Naples Yellow Light	10.31
A00461-7073	Olive Green	13.78
A00461-7373	Oxide of Chromium	25.79
A00461-3843	Pale Rose Blush	13.78
A00461-2563	Payne's Gray	10.31
A00461-3393	Permanent Aliz Crim	25.79
A00461-3163	Permanent Carmine	13.78

1.25 oz (37 ml) Tubes		
NUMBER	COLOR	EACH
A00461-7553	Permanent Green	13.78
A00461-7083	Permanent Green Deep	13.78
A00461-7313	Permanent Green Light	13.78
A00461-3493	Permanent Magenta	13.78
A00461-6433	Permanent Mauve	25.79
A00461-3263	Permanent Rose	13.78
A00461-2243	Perylene Black	10.31
A00461-5223	Prussian Blue	10.31
A00461-2573	Pewter Gray	13.78
A00461-5423	Phthalo Turquoise	10.31
A00461-7583	Prussian Green	13.78
A00461-6103	Purple Lake	10.31
A00461-6403	Purple Madder	13.78
A00461-3623	Quinacridone Magenta	13.78
A00461-3273	Quin	



Royal Talens™ Cobra™ Artists' Water Mixable Oil Colors

Enjoy solvent-free oil painting with Cobra. It offers the same properties as traditional oil colors, but you can mix it with water — no solvents required! The range consists of 70 transparent, semi-transparent, semi-opaque, and opaque colors, including 32 colors made from a single pigment. Highly lightfast. Colors can be assorted for quantity pricing.

1.35 oz (40 ml) Tubes

NUMBER	COLOR	EACH	6/EA
A02109-5393	Blue Violet	\$14.53	\$13.06
A02109-8043	Burnt Sienna	10.61	9.54
A02109-8053	Burnt Umber	10.61	9.54
A02109-4543	Cadmium Orange	24.35	21.92
A02109-3203	Cadmium Red Deep	24.35	21.92
A02109-3093	Cadmium Red Light	24.35	21.92
A02109-3103	Cadmium Red Medium	24.35	21.92
A02109-4123	Cadmium Yellow Deep	24.35	21.92
A02109-4183	Cadmium Ylw Lemon	24.35	21.92
A02109-4093	Cadmium Yellow Med	24.35	21.92
A02109-3153	Carmine	14.53	13.06
A02109-5173	Cerulean Blue	24.35	21.92
A02109-5963	Cerulean Blue Phthalo	10.61	9.54
A02109-7113	Chromium Oxide Grn	24.35	21.92
A02109-5183	Cobalt Blue	24.35	21.92
A02109-5893	Cobalt Blue Ultra	14.53	13.06
A02109-9163	Deep Gold (Metallic)	14.53	13.06
A02109-7053	Emerald Green	10.61	9.54
A02109-2693	Grayish Blue	10.61	9.54

NUMBER	COLOR	EACH	6/EA
A02109-4163	Indian Yellow	\$14.53	\$13.06
A02109-2253	Ivory Black	9.31	8.39
A02109-5913	King's Blue	14.53	13.06
A02109-2023	Lamp Black	9.31	8.39
A02109-9013	Light Gold (Metallic)	14.53	13.06
A02109-3713	Light Oxide Red	10.61	9.54
A02109-3173	Madder Lake	10.61	9.54
A02109-4523	Naples Yellow Deep	14.53	13.06
A02109-4793	Naples Yellow Light	14.53	13.06
A02109-4893	Naples Yellow Red	14.53	13.06
A02109-7073	Olive Green	14.53	13.06
A02109-2563	Payne's Gray	10.61	9.54
A02109-5923	Permanent Blue Vit	14.53	13.06
A02109-7333	Permanent Green Dp	14.53	13.06
A02109-7313	Permanent Green Lt	14.53	13.06
A02109-4393	Permanent Lemon Ylw	10.61	9.54
A02109-4913	Permanent Orange	10.61	9.54
A02109-3733	Permanent Red Violet	14.53	13.06
A02109-3723	Permanent Red Vit Lt	14.53	13.06
A02109-4873	Permanent Yellow Dp	10.61	9.54
A02109-4933	Permanent Yellow Lt	10.61	9.54
A02109-4383	Permanent Yellow Med	10.61	9.54
A02109-3413	Persian Rose	10.61	9.54
A02109-5163	Phthalo Blue	14.53	13.06
A02109-7803	Phthalo Green	14.53	13.06
A02109-5423	Phthalo Turq Blue	14.53	13.06
A02109-5953	Primary Cyan	10.61	9.54
A02109-3783	Primary Magenta	14.53	13.06
A02109-4533	Primary Yellow	10.61	9.54
A02109-5223	Prussian Blue	14.53	13.06
A02109-3763	Pyrrrole Red	14.53	13.06
A02109-3773	Pyrrrole Red Deep	14.53	13.06
A02109-3743	Pyrrrole Red Light	14.53	13.06
A02109-8063	Raw Sienna	10.61	9.54
A02109-8073	Raw Umber	14.53	13.06
A02109-7093	Sap Green	14.53	13.06
A02109-9333	Silver (Metallic)	14.53	13.06
A02109-8623	Titanium Buff	14.53	13.06
A02109-1023	Titanium White	9.31	8.39

NUMBER	COLOR	EACH	6/EA
A02109-3123	Transparent Oxide Red	\$14.53	\$13.06
A02109-4923	Transparent Oxide Ylw	14.53	13.06
A02109-3793	Transparent Red Med	14.53	13.06
A02109-4573	Transparent Ylw Med	14.53	13.06
A02109-5113	Turquoise Blue	14.53	13.06
A02109-5233	Ultramarine	10.61	9.54
A02109-8313	Vandyke Brown	10.61	9.54
A02109-3283	Vermilion	10.61	9.54
A02109-6513	Violet	14.53	13.06
A02109-4043	Yellow Ochre	10.61	9.54
A02109-4753	Yellowish Green	14.53	13.06
A02109-1033	Zinc White	9.31	8.39



Value Set of 10



Starter Set of 5

Royal Talens™ Cobra™ Artists' Water Mixable Oil Color Sets

For set colors, visit DickBlick.com.

NUMBER	SET	EACH	3/EA
A02109-1059	Mixing Set of 5, 0.67 oz (20 ml) Tubes	\$22.24	\$19.99
A02109-0059	Starter Set of 5, 1.35 oz (40 ml) Tubes	45.59	41.03
A02109-0109	Value Set of 10, 1.35 oz (40 ml) Tubes	89.58	80.62
A02109-1109	Combo Set of 10, 1.35 oz (40 ml) Tubes	118.76	106.87



Starter Set of 6



Introduction Set of 10



Selection Set of 10

Daler-Rowney™ Georgian Water Mixable Oil Color Sets

For set colors, visit DickBlick.com.

NUMBER	DESCRIPTION	EACH	6/EA
A02128-1009	Starter Set of 6, 0.67 oz (20 ml) Tubes	\$27.63	\$24.87
A02128-1019	Introduction Set of 10, 0.67 oz (20 ml) Tubes	38.99	35.10
A02128-1029	Selection Set of 10, 1.25 oz (37 ml) Tubes	58.04	52.23



Daler-Rowney™ Georgian Water Mixable Oils

Georgian Water Mixable Oils can be thinned, mixed, and washed up using plain water, without the need for solvents. Like traditional Georgian Oils, they offer high pigment loads, a smooth texture, and dependable lightfastness. Colors can be assorted for quantity pricing.

COLOR	1.25 OZ (37 ML)	EACH	6/EA	6.76 OZ (200 ML)	EACH	6/EA
Buff Titanium	A02128-8623	\$6.84	\$6.15	A02128-8624	\$18.08	\$16.28
Burnt Sienna	A02128-8043	6.84	6.15	A02128-8044	18.08	16.28
Burnt Umber	A02128-8053	6.84	6.15	A02128-8054	18.08	16.28
Cadmium Orange Hue	A02128-4543	6.84	6.15	—	—	—
Cadmium Red Deep Hue	A02128-3713	6.84	6.15	—	—	—
Cadmium Red Hue	A02128-3543	6.84	6.15	A02128-3544	18.08	16.28
Cadmium Red Lt Hue	A02128-3723	6.84	6.15	—	—	—
Cadmium Yellow Deep Hue	A02128-4123	6.84	6.15	—	—	—
Cadmium Yellow Hue	A02128-4353	6.84	6.15	A02128-4354	18.08	16.28
Cadmium Yellow Pale Hue	A02128-4113	6.84	6.15	A02128-4304	18.08	16.28
Cinnabar Green Light Hue	A02128-7693	6.84	6.15	A02128-7914	18.08	16.28
Cobalt Blue Hue	A02128-5183	6.84	6.15	A02128-5184	18.08	16.28
Cobalt Violet Hue	A02128-6523	6.84	6.15	—	—	—
Coeruleum Hue	A02128-5013	6.84	6.15	A02128-5014	18.08	16.28
Crimson Alizarin Hue	A02128-3163	6.84	6.15	A02128-3164	18.08	16.28
Peach Pink	A02128-4913	6.84	6.15	A02128-4914	18.08	16.28
French Ultramarine	A02128-5273	6.84	6.15	A02128-5274	18.08	16.28
Ivory Black	A02128-2253	6.84	6.15	A02128-2254	18.08	16.28
Lemon Yellow	A02128-4063	6.84	6.15	A02128-4064	18.08	16.28
Naples Yellow	A02128-4143	6.84	6.15	A02128-4144	18.08	16.28
Olive Green	A02128-7073	6.84	6.15	A02128-7074	18.08	16.28
Payne's Grey	A02128-2563	6.84	6.15	A02128-2564	18.08	16.28
Permanent Green Light	A02128-7013	6.84	6.15	—	—	—
Perm Red Violet Lt	A02128-3553	6.84	6.15	—	—	—
Primary Cyan	A02128-5953	6.84	6.15	—	—	—
Primary Magenta	A02128-3763	6.84	6.15	A02128-3764	18.08	16.28
Primary Yellow	A02128-4533	6.84	6.15	A02128-4534	18.08	16.28
Prussian Blue	A02128-5223	6.84	6.15	A02128-5224	18.08	16.28
Raw Sienna	A02128-8063	6.84	6.15	A02128-8064	18.08	16.28
Raw Umber	A02128-8073	6.84	6.15	A02128-8074	18.08	16.28
Rose Madder	A02128-3503	6.84	6.15	A02128-3504	18.08	16.28
Sap Green	A02128-7093	6.84	6.15	A02128-7094	18.08	16.28
Sevres Blue	A02128-5463	6.84	6.15	A02128-5464	18.08	16.28
Sky Blue	A02128-5073	6.84	6.15	A02128-5074	18.08	16.28
Titanium White	A02128-1023	6.84	6.15	A02128-1024	18.08	16.28
Turquoise	A02128-5113	6.84	6.15	—	—	—
Vandyke Brown Hue	A02128-8923	6.84	6.15	—	—	—
Viridian Hue	A02128-7433	6.84	6.15	A02128-7434	18.08	16.28
Yellow Ochre	A02128-4043	6.84	6.15	A02128-4044	18.08	16.28
Zinc White	A02128-1033	6.84	6.15	A02128-1034	18.08	16.28

HEALTH & SAFETY ICONS: ●=CL / ■=Prop 65 / ▼=CL & Prop 65 See page 644 for more information.



Winsor & Newton Artisan™ Water Mixable Oil Color Studio Set

Contains 10 colors in 1.25 oz (37 ml) tubes, including Lemon Yellow, Cadmium Yellow Hue, Permanent Alizarin Crimson, Cadmium Red Hue, Cerulean Blue Hue, French Ultramarine, Phthalo Green (Blue Shade), Yellow Ochre, Burnt Umber, and Titanium White, plus water mixable linseed oil medium and two brushes.

NUMBER	EACH
A00462-1019	\$76.29



Winsor & Newton Artisan™ Water Mixable Oil Color Beginner Set

Contains six colors in 1.25 oz (37 ml) tubes, including one each of Cadmium Yellow Pale Hue, Permanent Alizarin Crimson, French Ultramarine, Phthalo Green (Blue Shade), Yellow Ochre, and Titanium White.

NUMBER	EACH
A00462-1009	\$34.35

A-E Winsor & Newton Artisan™ Mediums

NUMBER	SIZE	EACH
A00459-2504	2.54 oz (75 ml)	\$8.43
A00459-2106	2 oz (60 ml)	\$9.99
A00459-2100	6.76 oz (200 ml)	19.99
A00459-2204	2.54 oz (75 ml)	\$8.43
A00459-2202	8.4 oz (250 ml)	16.75
A00459-2304	2.54 oz (75 ml)	\$8.43
A00459-2302	8.4 oz (250 ml)	16.75

Winsor & Newton™ Artisan™ Water Mixable Oil Colors

Paint solvent-free with these economically priced, genuine oil colors that clean up with soap and water. When used with non-hazardous Winsor & Newton Artisan mediums, artists are able to execute all the traditional oil painting techniques.

COLOR	1.25 OZ (37 ML)	EACH	6.76 OZ (200 ML)	EACH
Burnt Sienna	A00462-8043	\$7.63	A00462-8045	\$20.21
Burnt Umber	A00462-8053	7.63	A00462-8055	20.21
Cadmium Orange Hue	A00462-4543	7.63	A00462-4545	20.21
Cadmium Red Dark	A00462-3713	13.60	—	—
Cadmium Red Dp Hue	A00462-3323	7.63	A00462-3325	20.21
Cadmium Red Hue	A00462-3543	7.63	A00462-3545	20.21
Cadmium Red Light	A00462-3093	13.73	—	—
Cadmium Red Medium	A00462-3103	13.73	—	—
Cadmium Yellow Hue	A00462-4353	7.63	A00462-4355	20.21
Cadmium Yellow Light	A00462-4073	13.73	—	—
Cadmium Yellow Med	A00462-4093	13.73	—	—
Cadmium Ylw Dp Hue	A00462-4283	7.63	—	—
Cadmium Ylw Pale Hue	A00462-4253	7.63	A00462-4255	20.21
Cerulean Blue	A00462-5163	13.73	A00462-5165	42.75
Cerulean Blue Hue	A00462-5173	7.63	A00462-5175	20.21
Cobalt Blue	A00462-5183	13.73	—	—
Cobalt Blue Hue	A00462-5193	7.63	A00462-5195	20.21
Dioxazine Purple	A00462-6023	7.63	A00462-6025	20.21
French Ultramarine	A00462-5273	7.63	A00462-5275	20.21
Indian Red	A00462-3253	7.63	—	—
Ivory Black	A00462-2253	7.63	A00462-2255	20.21
Lamp Black	A00462-2023	7.63	A00462-2025	20.21
Lemon Yellow	A00462-4063	7.63	A00462-4065	20.21
Magenta	A00462-3043	7.63	A00462-3045	20.21
Naples Yellow Hue	A00462-4243	7.63	A00462-4245	20.21
Olive Green	A00462-7073	7.63	A00462-7075	20.21
Payne's Gray	A00462-2563	7.63	A00462-2565	20.21
Permanent Aliz Crim	A00462-3393	7.63	A00462-3395	20.21
Permanent Rose	A00462-3263	7.63	A00462-3265	20.21
Permanent Sap Green	A00462-7393	13.73	A00462-7395	42.75
Phthalo Blue and (RS)	A00462-5743	7.63	A00462-5745	20.21
Phthalo Green (BS)	A00462-7183	7.63	A00462-7185	20.21
Phthalo Green (YS)	A00462-7563	7.63	A00462-7565	20.21
Prussian Blue	A00462-5223	7.63	A00462-5225	20.21
Raw Sienna	A00462-8063	7.63	A00462-8065	20.21
Raw Umber	A00462-8073	7.63	A00462-8075	20.21
Titanium White	A00462-1013	7.63	A00462-1015	20.21
Viridian	A00462-7103	13.73	—	—
Yellow Ochre	A00462-4043	7.63	A00462-4045	20.21
Zinc White	A00462-1033			



Grumbacher Max Water Mixable Oils

These professional-quality, water mixable oil colors are made from the same pigments and linseed oil as Grumbacher Pre-Tested Oils with one major difference — they thin and clean up with water, so there's no need for turpentine, mineral spirits, or brush cleaning solutions. Interchangeable with

traditional oil colors. Colors can be assorted for quantity pricing.

NUMBER	COLOR	EACH	12/EA
A00414-3063	Alizarin Crimson	\$13.82	\$12.44
A00414-8043	Burnt Sienna	8.49	7.63
A00414-8053	Burnt Umber	8.49	7.63
A00414-4723	Cadmium Bar Orange	18.14	16.33
A00414-3713	Cadmium Bar Red Dp	22.04	19.83
A00414-3723	Cadmium Bar Red Lt	22.04	19.83
A00414-3733	Cadmium Bar Red Med	22.04	19.83
A00414-3743	Cad Bar Verm Hue	22.04	19.83
A00414-4623	Cadmium Bar Ylw Dp	18.14	16.33
A00414-4633	Cadmium Bar Ylw Lt	18.14	16.33
A00414-4643	Cadmium Bar Ylw Med	18.14	16.33
A00414-4713	Cadmium Bar Ylw Org	18.14	16.33
A00414-4653	Cadmium Bar Ylw Pale	18.14	16.33
A00414-5163	Cerulean Blue	25.76	23.18
A00414-7113	Chrom Oxide Green	13.82	12.44
A00414-5183	Cobalt Blue	22.04	19.83
A00414-5373	Cobalt Turquoise	18.14	16.33
A00414-4493	Diarylide Yellow	13.82	12.44
A00414-6023	Dioxazine Purple	13.82	12.44
A00414-3863	Flesh Hue	11.27	10.14
A00414-5273	French Ultra Blue	11.27	10.14
A00414-9233	Golden Ochre Hue	8.49	7.63
A00414-7913	Green Earth Hue	8.49	7.63
A00414-3753	Grum Red (Naphthol)	13.82	12.44
A00414-2253	Ivory Black	8.49	7.63
A00414-2023	Lamp Black	8.49	7.63
A00414-2043	Mars Black	11.27	10.14
A00414-4243	Naples Yellow Hue	11.27	10.14
A00414-4823	Nickel Titan Yellow	18.22	16.40
A00414-2563	Payne's Gray	11.27	10.14
A00414-5783	Permanent Blue	11.27	10.14
A00414-7923	Perm Bright Green	11.27	10.14
A00414-8913	Pryln Maroon (Anthra)	18.14	16.33
A00414-5223	Prussian Blue	11.27	10.14
A00414-4913	Quinacridone Orange	18.14	16.33
A00414-3273	Quinacridone Red	13.82	12.44
A00414-8063	Raw Sienna	8.49	7.63
A00414-8073	Raw Umber	8.49	7.63
A00414-7093	Sap Green	13.82	12.44
A00414-5143	Thalo Blue	13.82	12.44
A00414-7183	Thalo Green BS	13.82	12.44
A00414-7563	Thalo Green YS	13.82	12.44
A00414-3773	Thalo Red Rose	18.14	16.33
A00414-7573	Thalo Yellow Green	11.27	10.14
A00414-6553	Thio Violet	11.27	10.14
A00414-1013	Titan White	8.49	7.63
A00414-1014	Titan White, 150 ml	22.90	20.60
A00414-5253	Ultra Blue Deep	11.27	10.14
A00414-3783	Ultramarine Red	11.27	10.14
A00414-3133	Venetian Red	8.49	7.63
A00414-4043	Yellow Ochre	8.49	7.63
A00414-1033	Zinc White	8.49	7.63
A00414-4433	Zinc Yellow Hue	11.27	10.14

HOLBEIN

Holbein Duo Aqua Oil Colors

Developed by Holbein to offer the same qualities and characteristics of its Artists' Oils line while allowing soap-and-water cleanup, Duo Aqua Oils are characterized by rich hues, high chroma, and 17 "Elite" colors that contain genuine heavy metal pigments such as cadmium and cobalt. Colors can be assorted for quantity pricing.

NUMBER	COLOR	EACH	6/EA
A00494-3063	Alizarin Crimson	\$14.83	\$13.35
A00494-3393	Anthraquinone Red	14.83	13.35
A00494-4273	Aureolin Hue	19.48	17.54
A00494-4193	Benzidine Yellow	14.83	13.35
A00494-3053	Brilliant Pink	14.83	13.35
A00494-8343	Brown Pink	19.48	17.54
A00494-8053	Burnt Umber	11.50	10.35
A00494-8043	Burnt Sienna	11.50	10.35
A00494-7043	Cadmium Grn Dp Hue	11.50	10.35
A00494-7213	Cadmium Green	27.78	24.99
A00494-7003	Cadmium Green Hue	11.50	10.35
A00494-7223	Cadmium Green Light	27.78	24.99
A00494-7013	Cadmium Grn Lt Hue	11.50	10.35
A00494-4543	Cadmium Orange	34.91	31.42
A00494-3203	Cadmium Red Deep	34.91	31.42
A00494-3713	Cadmium Red Dp Hue	11.50	10.35
A00494-3333	Cadmium Red	34.91	31.42
A00494-3003	Cadmium Red Hue	11.50	10.35
A00494-3013	Cadmium Red Prpl Hue	11.50	10.35
A00494-4123	Cadmium Yellow Deep	27.78	24.99
A00494-4323	Cadmium Ylw Dp Hue	11.50	10.35
A00494-4203	Cadmium Yellow	27.78	24.99
A00494-4003	Cadmium Yellow Hue	11.50	10.35
A00494-4183	Cadmium Yellow Lmn	27.78	24.99
A00494-4013	Cadmium Ylw Lt Hue	11.50	10.35
A00494-5173	Cerulean Blue	34.91	31.42
A00494-5163	Cerulean Blue Hue	14.83	13.35
A00494-5193	Cobalt Blue	34.91	31.42
A00494-5003	Cobalt Blue Hue	11.50	10.35
A00494-7663	Cobalt Green Deep	27.78	24.99
A00494-7903	Cobalt Green Light	27.78	24.99
A00494-5373	Cobalt Turquoise	34.91	31.42
A00494-6523	Cobalt Violet	46.69	41.99
A00494-4923	Coral Red	14.83	13.35
A00494-6913	Dioxazine Violet	14.83	13.35
A00494-7023	Emerald Green Nova	14.83	13.35
A00494-4773	Greenish Yellow	19.48	17.54
A00494-8913	Grey of Grey	11.50	10.35
A00494-5453	Horizon Blue	14.83	13.35
A00494-7063	Ice Green	14.83	13.35
A00494-8933	Imidazolone Brown	14.83	13.35
A00494-4593	Imidazolone Orange	19.48	17.54
A00494-4913	Imidazolone Yellow	14.83	13.35
A00494-4903	Imidazolone Yellow Lt	14.83	13.35
A00494-5343	Indanthrene Blue	14.83	13.35
A00494-4743	Indian Yellow	14.83	13.35
A00494-5203	Indigo	14.83	13.35
A00494-2263	Ivory Black Hue	11.50	10.35
A00494-3903	Jaune Brilliant	14.83	13.35
A00494-6043	Lavender	14.83	13.35
A00494-7153	Leaf Green	14.83	13.35
A00494-4063	Lemon Yellow	11.50	10.35
A00494-3043	Light Magenta	14.51	13.06
A00494-6033	Lilac	14.83	13.35
A00494-7033	Luminous Green	19.48	17.54
A00494-4083	Luminous Lemon	19.48	17.54
A00494-3773	Luminous Opera	19.48	17.54
A00494-4533	Luminous Orange	19.48	17.54
A00494-6903	Luminous Violet	19.48	17.54
A00494-5553	Manganese Blue Nova	14.83	13.35
A00494-6073	Mauve	14.83	13.35
A00494-6703	Mineral Violet	19.48	17.54
A00494-5043	Navy Blue	14.83	13.35
A00494-3603	Naphthol Red	14.83	13.35
A00494-4143	Naples Yellow	14.83	13.35
A00494-4793	Naples Yellow Light	14.83	13.35
A00494-7073	Olive Green	19.48	17.54
A00494-2563	Paynes Grey	11.50	10.35
A00494-5223	Prussian Blue	14.83	13.35
A00494-7583	Prussian Green	14.83	13.35
A00494-5213	Phthalo Blue	14.83	13.35
A00494-7803	Phthalo Green	14.83	13.35
A00494-7563	Phthalo Green Yellow	14.83	13.35
A00494-9093	Quinacridone Gold	19.48	17.54
A00494-3093	Quinacridone Scarlet	19.48	17.54
A00494-3273	Quinacridone Red	19.48	17.54
A00494-6513	Quinacridone Violet	14.83	13.35
A00494-8063	Raw Sienna	11.50	10.35
A00494-8073	Raw Umber	11.50	10.35

NUMBER	COLOR	EACH	6/EA
A00494-3173	Rose Dore	\$19.48	\$17.54
A00494-3723	Rose Madder	14.83	13.35
A00494-3743	Rose Violet	19.48	17.54
A00494-7093	Sap Green	14.83	13.35
A00494-8083	Sepia	14.83	13.35
A00494-7933	Shadow Green	19.48	17.54
A00494-2343	Spinel Black	14.83	13.35
A00494-3753	Terra Rosa	11.50	10.35
A00494-7923	Terra Verte Hue	14.83	13.35
A00494-5113	Turquoise Blue	14.83	13.35
A00494-5253	Ultramarine Deep	11.50	10.35
A00494-5233	Ultramarine Light	11.50	10.35
A00494-5653	Verditer Blue	14.83	13.35
A00494-3763	Vermilion Hue	11.50	10.35
A00494-7053	Viridian Hue	14.83	13.35
A00494-4753	Yellow Green	11.50	10.35
A00494-4043	Yellow Ochre	11.50	10.35
A00494-4453	Yellow Ochre Natural	11.50	10.35

NUMBER	COLOR	EACH	6/EA
A00494-1395	Ceramic White	\$24.45	\$21.99
A00494-1015	Permanent White	15.06	13.57
A00494-1025	Titanium White	15.06	13.57

NUMBER	COLOR	EACH	6/EA
A00494-1394	Ceramic White	\$46.83	\$42.14
A00494-1014	Permanent White	30.42	27.37
A00494-1024	Titanium White	30.42	27.37

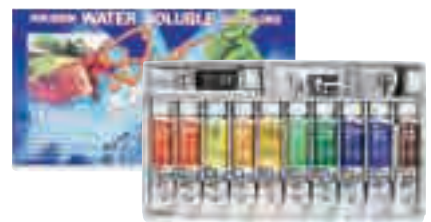

Assorted Set of 12



Color and Quick Drying Medium Set

Holbein Duo Aqua Oil Sets

Assorted Set of 12 — Contains 0.68 oz (20 ml) tubes of Cadmium Red Deep Hue, Vermilion Hue, Lemon Yellow, Yellow Ochre, Cadmium Yellow Light Hue, Cadmium Green Hue, Ultramarine Light, Cobalt Blue Hue, Burnt Sienna, and Ivory Black, plus a 1.69 oz (50 ml) tube of Permanent White.

NUMBER	EACH	6/EA
A00494-1209	\$115.73	\$104.16

Color and Quick Drying Medium Set — 18, 0.68 oz (20 ml) Duo colors plus a 1.7 oz (50 ml) tube of Quick Drying Medium Gloss Paste, which adds body, imparts a transparent gloss finish, and accelerates drying time.

NUMBER	EACH	6/EA
A00494-1020	\$215.19	\$193.66



Introductory, Set of 6



Painter's Dozen, Set of 12

R&F™ Pigment Stick Sets

1.28 oz (38 ml) pigment sticks. Introductory, Set of 6 — Naples Yellow, Cadmium Green Pale, King's Blue, Turkey Red, Turkey Umber, and Neutral White.

NUMBER	EACH
A01107-1029	\$72.19

Chromatic Tones, Set of 6 — Brilliant Yellow Extra Pale, Green Gold Pale, Scarlet Extra Pale, Celadon Green, Ultramarine Blue, and Cerulean Grey.

NUMBER	EACH
A01107-1039	\$72.19

Earth Tones, Set of 6 — Neutral White, Unbleached Titanium, Brown Pink, Stil de Grain, Green Earth, and Blue Ochre.

NUMBER	EACH
A01107-1049	\$72.19

Painter's Dozen II, Set of 12 — Blue Ochre, Turkey Red, Magenta Earth, Stil De Grain, Olive Yellow, Permanent Green, Cobalt Teal, Unbleached Titanium, Ultramarine Blue, Phthalo Green Pale, Green Gold Pale, and Cerulean Grey. Includes a cradled 6-1/2" x 7-1/2" Ampersand Gessobord.

NUMBER	EACH
A01107-1059	\$201.97



Set of 27 Mini Paintstiks

Shiva Artist's Mini Paintstik Oil Color Class Packs

Mini sticks are 1-1/2" x 5/8". The Set of 54 contains double the contents of the Set of 27. For set colors, visit DickBlick.com.

NUMBER	SET	EACH	5/EA
A00409-2009	27 Colors	\$129.19	\$116.27
A00409-3009	54 Colors	243.04	218.73

Richeson Oil Sticks The Shiva Series

Paintstik Oil Colors can be spread or blended with a brush, knife, or colorless blender. They dry to the touch in 24 hours and can be blended with any oil paint. Use turpentine to thin. Colors can be assorted for quantity pricing.

NUMBER	COLOR	EACH	12/EA
A00409-3064	Alizarin Crimson	\$9.11	\$8.21
A00409-1204	Antique White	9.11	8.21
A00409-8184	Asphaltum	9.11	8.21
A00409-4914	Azo Orange	9.11	8.21
A00409-4454	Azo Yellow	9.11	8.21
A00409-3714	Barn Red	9.11	8.21
A00409-8144	Beige	9.11	8.21
A00409-8044	Burnt Sienna	9.11	8.21
A00409-8054	Burnt Umber	9.11	8.21
A00409-4534	Cadmium Orange	16.85	15.16
A00409-3204	Cadmium Red Deep	16.85	15.16
A00409-3564	Cadmium Red Scarlet	16.85	15.16
A00409-4204	Cadmium Yellow	13.55	12.20
A00409-7484	Celadon Green	9.11	8.21
A00409-8104	Chocolate	9.71	8.75
A00409-7114	Chrom Oxide Green	13.55	12.20
A00409-5184	Cobalt Blue	16.85	15.16
A00409-6024	Dioxazine Purple	13.55	12.20
A00409-3724	Dusty Rose	9.11	8.21
A00409-6094	Grape	9.11	8.21
A00409-5564	Ice Blue	9.11	8.21
A00409-8001	Iridescent Brown	11.59	10.43
A00409-2131	Iridescent Charcoal	11.59	10.43
A00409-8111	Iridescent Copper	11.59	10.43
A00409-5031	Iridescent Dark Blue	11.59	10.43
A00409-4051	Iridescent Gold	11.59	10.43
A00409-6091	Iridescent Grape	11.59	10.43
A00409-7006	Iridescent Green	11.59	10.43
A00409-7221	Iridescent Jade	11.59	10.43
A00409-7156	Iridescent Leaf Green	11.59	10.43
A00409-4911	Iridescent Light Gold	11.59	10.43
A00409-7231	Iridescent Lime	11.59	10.43
A00409-3041	Iridescent Magenta	11.59	10.43
A0			

Utrecht mediums



A Utrecht Linseed Oil

Mix this alkali-refined linseed oil with oil colors to give them a more transparent, fluid consistency and extend their drying time (useful for wet-in-wet techniques).

NUMBER	SIZE	EACH
A01765-1097	32 oz (946 ml)	\$16.05

B Utrecht Safflower Oil

Naturally neutral in color, Utrecht Safflower Oil is a good vehicle for painting with whites and transparent colors. It has less of a tendency to yellow over time than linseed oil.

NUMBER	SIZE	EACH
A01765-1166	16 oz (473 ml)	\$13.82

C Utrecht Stand Oil

Use instead of linseed oil for a smooth, enamel-like finish with less visible brushwork. Non-yellowing and 100% pure.

NUMBER	SIZE	EACH
A01765-1177	32 oz (946 ml)	\$15.42

Utrecht Oil Painting Medium

Utrecht's exclusive blend of damar gum, linseed oil, and artist's pure gum turpentine makes oil colors more fluid, enhances their gloss level, and increases their brilliance. Paint dries to a more flexible and durable film. A great general-purpose medium.

NUMBER	SIZE	EACH
A01765-1125	8 oz (237 ml)	\$15.67

Blick Studio Linseed Oil

Pressed from top-quality flax seeds, this oil contains no free mineral acids. Mix it with oil and alkyd colors for smoother color application and better blending. Or combine it with turpentine or mineral spirits to create your own custom painting mediums. Use it full strength to remove oil paint from brushes. Made with certified non-toxic raw materials.

NUMBER	SIZE	EACH
A01566-1050	8 oz (237 ml)	\$7.41
A01566-1060	16 oz (473 ml)	10.59

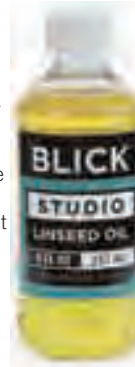

Sennelier #Green for Oil Mediums

A safer, eco-friendly alternative. Made from renewable raw materials, these bio-solvents are 100% safe and just as effective as traditional mediums. Non-toxic.

Gel Medium — For artists who want to use heavy paints and build up texture. Preserves consistency without making your oils too fluid. Also speeds up drying times.

NUMBER	DESCRIPTION	SIZE	EACH
A01046-1203	Gel Medium	1.5 oz (40 ml)	\$8.62
A01046-1004	Gel Medium	8.5 oz (250 ml)	22.29

Liquid Medium — Improves consistency and works well for creating glazes and impasto effects. Great for working wet. Speeds up drying times and gives work a glossy finish.

NUMBER	DESCRIPTION	SIZE	EACH
A01046-1103	Liquid Medium	3.38 oz (100 ml)	\$13.74
A01046-1003	Liquid Medium	8.5 oz (250 ml)	22.29



Schmincke Medium W

Revolutionary Medium W transforms any traditional oil color into water mixable oil! Just mix one part medium with two parts color, and say goodbye to the need for volatile diluents. Use simple water as desired for thinning as well as cleaning your tools.

NUMBER	SIZE	EACH	12/EA
A01039-1060	2 oz (60 ml)	\$20.04	\$18.04
A01039-1020	6.76 oz (200 ml)	42.11	37.90
A01039-1010	33.8 oz (Liter)	102.79	92.34

Grumbacher Linseed Oil

This purified, alkali-refined linseed oil offers excellent blending and adhesion for the professional artist. Use as a binder with powdered pigments; add to oil paints to increase gloss, fluidity, and transparency.

NUMBER	SIZE	EACH	12/EA
A00457-1104	2.5 oz (74 ml)	\$7.70	\$6.92
A00457-1105	8 oz (237 ml)	15.36	13.81



Blick Studio Quick Glaze

A soft, translucent gel that thins and extends colors and speeds drying time. Ideal for glazing and underpainting, it dries to a durable, flexible film that resists yellowing.

NUMBER	SIZE	EACH
A01566-1030	8 oz (237 ml)	\$12.23
A01566-1040	16 oz (473 ml)	18.67



1.89 Liter (Half Gallon) and 3.78 Liter (Gallon) sizes cannot be shipped to California.

Gamblin Galkyd Medium

An alkyd resin painting medium that increases the fluidity of oil colors and speeds their drying time. Viscosity is similar to traditional painting mediums made from linseed stand oil. It levels brushstrokes, creates a strong flexible paint film, and leaves an enamel-like glossy finish. Glass bottles.

NUMBER	SIZE	EACH
A00456-1015	8.5 oz (250 ml)	\$18.07
A00456-1106	16.9 oz (500 ml)	29.50
A00456-1007	33.8 oz (1 Liter)	50.52



Gamblin Cold Wax Medium

This soft paste formulated to knife consistency is used to make oil colors thicker and more matte. It can be thinned with mineral spirits to brush consistency.

NUMBER	SIZE	EACH
A00456-1019	Gallon (3.78 Liter)	\$135.19
A00456-1006	16.9 oz (500 ml)	25.86



Dorland's Wax Medium

Dorland's adds translucency to oil paints, making them more brilliant. It may also be used as a final coat on dry paintings, metal sculpture, wood carvings, and antiques. May be buffed to a gloss finish. Thins with turpentine.

NUMBER	SIZE	EACH	12/EA
A00428-1004	4 oz (118 ml)	\$10.54	\$9.48
A00428-1016	16 oz (473 ml)	26.15	23.53
A00428-1009	Gallon (3.78 Liter)	133.31	119.98



Richeson Shiva Linseed Oil

A refined, white linseed oil that contains no free mineral acids, lead, or artificial driers. It serves to diminish the thickness of paint. The consistency is thinner than sun-thickened linseed (stand oil) and may darken with age.

NUMBER	SIZE	EACH	12/EA
A00437-1006	Pint (473 ml)	\$21.70	\$19.53
A00437-1007	Quart (946 ml)	34.81	31.32
A00437-1009	Gallon (3.78 Liter)	83.60	75.23



D Krylon Low Odor Clear Finish

Formulated with true latex technology, Krylon Low Odor Clear Finish provides the same quality as traditional Krylon coatings. 11 oz (325 ml) cans.

NUMBER	DESCRIPTION	EACH	12/EA
A23710-1001	Gloss	\$10.17	\$9.16
A23710-2001	Matte	10.17	9.16

E Krylon Kamar Varnish

Clear, lasting protection for oil, acrylic, and waterbased paints. Free of the impurities found in natural varnish so it will not yellow with age. Allows reworking of the paint and can be safely removed for future restoration.

NUMBER	SIZE	EACH	6/EA
A00435-1005	11 oz (325 ml)	\$11.46	\$10.31



Krylon Gallery Series UV Archival Varnish

Offers the highest UV protection available in a protective coating. Its non-yellowing formula protects against fading, dirt, moisture, and discoloration in artworks created using acrylic, oil, watercolor, pastel, and colored pencil. Removable for conservation purposes. 11 oz (311 g) cans.

NUMBER	DESCRIPTION	EACH	12/EA
A01743-2010	Gloss	\$16.75	\$15.08
A01743-2020	Semi Gloss	15.67	14.11
A01743-2030	Satin	16.75	15.08
A01743-2040	Matte	16.75	15.08

Golden Archival Spray Varnish

This protective archival finish for fine art offers excellent dirt, dust, and moisture resistance. Ultraviolet light filters and stabilizers (UVLS) inhibit light damage, and the adjustable fan spray tip allows for precise application with reduced overspray. Adheres to a wide variety of surfaces and paint mediums including acrylics, oils, alkyds, pastels, watercolors, tempera, and inkjet prints. 10 oz (300 ml) cans.

NUMBER	DESCRIPTION	EACH
A21717-1010	Gloss	\$18.42
A21717-1020	Satin	18.42
A21717-1030	Matte	18.42
A21717-1040	Semi-Gloss	18.42



Citra Solv Natural Citrus Cleaner

Ideal for those with chemical sensitivities, this versatile citrus solvent is great for cleaning brushes, tools, equipment, and clothing. It can also be used for fabric transfer, mixed media, altering magazine pages, photo transfers, and more.

NUMBER	SIZE	EACH
A01753-4905	8 oz (237 ml)	\$12.45
A01753-4906	16 oz (473 ml)	20.08
A01753-4907	32 oz (946 ml)	34.62



F Crown Odorless Paint Thinner

Artist-quality thinner that may be used in place of turpentine for reducing paint and cleanup of brushes, palettes, and spray equipment. Note: Gallon cannot be shipped to California.

NUMBER	SIZE	EACH
A01012-1007	Quart (946 ml)	\$12.75
A01012-1009	Gallon (3.78 Liter)	37.84

G Crown Low Odor Mineral Spirits

Low Odor Mineral Spirits can be used for thinning varnishes, enamels, oil, and alkyd paints. Excellent for cleaning brushes. Note: Gallon cannot be shipped to California.

NUMBER	SIZE	EACH	6/EA
A01032-1007	Quart (946 ml)	\$10.80	\$9.72
A01032-1009	Gallon (3.78 Liter)	35.27	31.79

Gamblin Solvent-Free Mediums

Available in Fluid or Gel. The Fluid Medium moderately speeds drying time. The Gel Medium gives colors more gloss, flow, and transparency. Both are non-toxic.

Solvent-Free Fluid

NUMBER	SIZE	EACH
A00456-1120	4.2 oz (124.20 ml)	\$11.30
A00456-1121	8.5 oz (251.37 ml)	18.07
A00456-1122	16.9 oz (499.79 ml)	29.50



Solvent-Free Gel

NUMBER	SIZE	EACH
A00456-1023	1.25 oz (37 ml)	\$5.74
A00456-1804	5 oz (150 ml)	19.96

Gamblin Gamsol Odorless Mineral Spirits

An excellent solvent for thinning Gamblin mediums, for general painting, and for brush and studio cleanup. Gamsol is less toxic than other brands of odorless mineral spirits, mineral spirits, or turpentine because the harmful aromatic solvent component has been removed. Note: Gallon cannot be shipped to California.

NUMBER	SIZE	EACH
A00456-1016	16.9 oz (500 ml)	\$15.20
A00456-1032	33.8 oz (1 Liter)	22.83
A00456-1128	Gallon (3.78 Liter)	59.99



Utrecht NOOD Odorless Thinner

NOOD (short for "No Odor") is a 100% pure, odorless, slow-evaporating thinner for artists' oil colors and oil mediums. With a flashpoint of 174°F, it is a safer alternative for studios and classrooms. Evaporation is very slow, allowing for extended open time, reduced exposure, and less waste.

NUMBER	SIZE	EACH
A02054-1004	4 oz (120 ml)	\$7.19
A02054-1005	8 oz (237 ml)	9.89
A02054-1006	16 oz (473 ml)	13.48
A02054-1007	32 oz (946 ml)	17.98
A02054-1008	Gallon (3.78 Liter)	38.21



H Weber Odorless Turpeneoid

This thin, colorless, refined turpentine substitute has the same properties as turpentine without the strong odor. Note: Gallon cannot be shipped to California.

NUMBER	SIZE	EACH
A00442-1004	4 oz (120 ml)	\$6.45
A00442-1005	8 oz (237 ml)	8.77
A00442-1006	Pint (473 ml)	11.46
A00442-1007	Quart (946 ml)	18.99
A00442-1009	Gallon (3.78 Liter)	34.64

I Weber Turpeneoid Light

A mild solvent with no harmful aromas and a very high (200°F/93°C) flashpoint, making it safer for studios and classrooms. Use it for thinning oil colors and cleaning brushes.

NUMBER	SIZE	EACH	12/EA
A01042-1005	8 oz (236 ml)	\$13.32	\$11.99
A01042-1006	16 oz (473 ml)	17.37	15.63

Utrecht Gum Turpentine

Dilute oil paints and alkyds, clean brushes and tools, and mix custom mediums. Utrecht Gum Turpentine is distilled from wood and is a better choice than mineral spirits for fine art applications.

NUMBER	SIZE	EACH
A01765-1072	32 oz (946 ml)	\$28.54



Blick Studio Damar Varnish

Made from high-quality natural resins, this varnish provides surface protection for oil and alkyd paintings by preventing dust and airborne contaminants from adhering. The high-gloss finish increases color brilliance. Removable with turpentine.

NUMBER	SIZE	EACH
A01566-1010	8 oz (237 ml)	\$15.23



R&F™ Encaustic Paints

Made in carefully controlled batches, they contain no additives and require no drying time. No solvents are used, eliminating many health hazards.

3.5 oz (104 ml) Cakes

NUMBER	COLOR	EACH
A01101-3180	Alizarin Crimson	\$40.62
A01101-4910	Alizarin Orange	36.26
A01101-5910	Azure Blue	29.65
A01101-5120	Blue Ochre	40.62
A01101-4810	Brlnt Ylw Ex Pale	29.65
A01101-8910	Brown Pink	36.26
A01101-8040	Burnt Sienna	27.09
A01101-8050	Burnt Umber	27.09
A01101-7620	Cad Green Pale	40.62
A01101-3100	Cad Red Med	46.52
A01101-4120	Cad Yellow Dp	40.62
A01101-4130	Cad Yellow Lt	40.62
A01101-4090	Cad Yellow Med	40.62
A01101-7210	Cadmium Green	40.62
A01101-4180	Cadmium Lemon	40.62
A01101-4530	Cadmium Orange	40.62
A01101-3210	Cadmium Red Deep	46.52
A01101-3090	Cadmium Red Light	46.52
A01101-7480	Celadon Green	29.65
A01101-5190	Cerulean Blue	51.80
A01101-5170	Cerulean Extra-Pale	36.26
A01101-5300	Cerulean Grey	29.65
A01101-7650	Chromium Oxide Grn	29.65
A01101-5180	Cobalt Blue	46.52
A01101-7930	Cobalt Green Light	58.07
A01101-5800	Cobalt Teal	40.62
A01101-5370	Cobalt Turquoise	46.52
A01101-6910	Cobalt Violet Deep	51.80
A01101-6580	Cobalt Violet Light	51.80
A01101-4820	Cobalt Yellow	58.07
A01101-7990	Courbet Green	29.65
A01101-3910	Dianthus Pink	36.26
A01101-6590	Egyptian Violet	40.62
A01101-3770	French Mauve Blue	46.52
A01101-3780	French Mauve Red	46.52
A01101-2690	Graphite Grey	29.65
A01101-7920	Green Earth	27.09
A01101-7450	Green Gold	40.62
A01101-7340	Green Gold Pale	29.65
A01101-4160	Indian Yellow	36.26
A01101-5200	Indigo	29.65
A01101-2120	Intns Carbon Black	29.65
A01101-9050	Iridescent Brass	46.52
A01101-8150	Iridescent Bronze	46.52

3.5 oz (104 ml) Cakes

NUMBER	COLOR	EACH
A01101-9530	Iridescent Copper	\$46.52
A01101-9310	Iridescent Grmn Silver	46.52
A01101-9010	Iridescent Gold	46.52
A01101-9370	Iridescent Pearl	46.52
A01101-2570	Iridescent Pewter	46.52
A01101-9320	Iridescent Silver	46.52
A01101-2250	Ivory Black	27.09
A01101-3900	Jaune Brilliant	36.26
A01101-5920	King's Blue	36.26
A01101-6620	Manganese Violet	36.26
A01101-2040	Mars Black	27.09
A01101-4670	Mars Orange	27.09
A01101-3040	Mars Red	27.09
A01101-6630	Mars Violet	27.09
A01101-4380	Mars Yellow Deep	27.09
A01101-4370	Mars Yellow Light	27.09
A01101-4140	Naples Yellow	29.65
A01101-1120	Neutral White	27.09
A01101-4750	Olive Yellow	36.26
A01101-2560	Payne's Grey	29.65
A01101-7550	Permanent Green	36.26
A01101-5160	Phthalo Blue	29.65
A01101-7800	Phthalo Green	29.65
A01101-7970	Phthalo Green Pale	29.65
A01101-5960	Phthalo Turquoise	29.65
A01101-3620	Quinacridone Magenta	40.62
A01101-3270	Quinacridone Red	40.62
A01101-8060	Raw Sienna	27.09
A01101-8070	Raw Umber	27.09
A01101-7090	Sap Green	36.26
A01101-8080	Sepia	36.26
A01101-4930	Stil De Grain	36.26
A01101-1020	Titanium White	27.09
A01101-3730	Turkey Red	36.26
A01101-7910	Turkey Umber Grnsh	27.09
A01101-5110	Turquoise Blue	29.65
A01101-5230	Ultramarine Blue	29.65
A01101-6730	Ultramarine Violet	40.62
A01101-4340	Unbleached Titanium	27.09
A01101-7980	Veronese Green	36.26
A01101-7940	Viridian	46.52
A01101-3760	Warm Pink	36.26
A01101-3170	Warm Rose	36.26



R&F™ Encaustic Paint Sets

For complete set contents, visit DickBlick.com.

Studio Essentials Kit

NUMBER	EACH
A01101-1013	\$607.00



Master Set

NUMBER	EACH
A01108-1019	\$734.00



Enkaustikos™ Hot Cakes™ Classic Painters Choice Set

Ready-to-use professional encaustic paints made from the most beautiful pigments, the finest damar resin, and USP beeswax. Set includes 10, 1.5 oz (45 ml) colors in convenient reusable metal tins, mediums, a hot wax pen, and more.

NUMBER	EACH
A01111-0069	\$261.26



Pebeo™ Vitrea 160

Thermo-hardening, transparent, non-toxic, waterbased paints specifically designed for use on glassware, vases, lamps, and more. Once dried and baked, they are permanent and dishwasher safe. Colors can be assorted for quantity pricing.

Shimmer — 1.5 oz (45 ml) Bottles

NUMBER	COLOR	EACH	5/EA
A02950-9013	Gold	\$8.72	\$7.85
A02950-9333	Silver	\$8.72	\$7.85

Glossy — 1.5 oz (45 ml) Bottles

NUMBER	COLOR	EACH	6/EA
A02950-3713	Amaranthine	\$7.19	\$6.47
A02950-3063	Bengal Pink	\$7.19	\$6.47
A02950-5593	Cyan	\$7.19	\$6.47
A02950-8833	Earth Brown	\$7.19	\$6.47
A02950-7053	Emerald	\$7.19	\$6.47
A02950-3253	Indian Red	\$7.19	\$6.47
A02950-2023	Ink Black	\$7.19	\$6.47
A02950-5013	Lacquer Blue	\$7.19	\$6.47
A02950-5003	Lapis	\$7.19	\$6.47
A02950-5043	Light Blue	\$7.19	\$6.47
A02950-7043	Light Green	\$7.19	\$6.47
A02950-3733	Light Pink	\$7.19	\$6.47
A02950-8303	Light Taupe	\$7.19	\$6.47
A02950-7003	Oriental Green	\$7.19	\$6.47
A02950-4503	Paprika	\$7.19	\$6.47
A02950-3003	Pepper Red	\$7.19	\$6.47
A02950-4963	Saffron Yellow	\$7.19	\$6.47
A02950-4913	Sun Yellow	\$7.19	\$6.47
A02950-5113	Turquoise	\$7.19	\$6.47
A02950-1013	Veil White	\$7.19	\$6.47
A02950-3703	Vivid Pink	\$7.19	\$6.47

Pebeo™ Vitrea 160 Set of 10

NUMBER	EACH	5/EA
A02950-1109	\$62.59	\$56.33

Pebeo™ Vitrea Paint - Initiation Set of 6

NUMBER	EACH	5/EA
A02950-1059	\$17.55	\$15.79

Frosted — 1.5 oz (45 ml) Bottles

NUMBER	COLOR	EACH	5/EA
A02950-5913	Azure	\$8.72	\$7.85
A02950-7033	Aniseed Green	\$8.72	\$7.85
A02950-1003	Cloud	\$8.72	\$7.85
A02950-4063	Lemon	\$8.72	\$7.85
A02950-3083	Pink	\$8.72	\$7.85

Outliners — 0.68 oz (20 ml) Tubes

NUMBER	COLOR	EACH	5/EA
A02950-7051	Emerald	\$8.72	\$7.85
A02950-9001	Gold	\$8.72	\$7.85
A02950-5011	Ink Black	\$8.72	\$7.85
A02950-5001	Lapis	\$8.72	\$7.85
A02950-4501	Paprika	\$8.72	\$7.85
A02950-1091	Pearl	\$8.72	\$7.85
A02950-3001	Pepper Red	\$8.72	\$7.85
A02950-2571	Pewter	\$8.72	\$7.85
A02950-4911	Sun Yellow	\$8.72	\$7.85
A02950-5111	Turquoise	\$8.72	\$7.85

Frosted Markers

NUMBER	COLOR	EACH	5/EA
A02950-7030	Aniseed	\$8.32	\$7.49
A02950-5910	Azure Blue	\$8.32	\$7.49
A02950-5020	Gitane Blue	\$8.32	\$7.49
A02950-4060	Lemon	\$8.32	\$7.49
A02950-7510	Mint	\$8.32	\$7.49
A02950-1001	Neutral Etch	\$8.32	\$7.49
A02950-3080	Pink	\$8.32	\$7.49
A02950-6500	Violet	\$8.32	\$7.49

Glossy Markers

NUMBER	COLOR	EACH	6/EA
A02950-4900	Amber Brown	\$7.19	\$6.47
A02950-3060	Bengal Pink	\$7.19	\$6.47
A02950-7050	Emerald	\$7.19	\$6.47
A02950-2020	Ink Black	\$7.19	\$6.47
A02950-4500	Paprika	\$7.19	\$6.47
A02950-3000	Pepper Red	\$7.19	\$6.47
A02950-7010	Sandalwood Green	\$7.19	\$6.47
A02950-4910	Sun Yellow	\$7.19	\$6.47
A02950-5110	Turquoise	\$7.19	\$6.47

Mediums - 1.5 oz (45 ml)

NUMBER	DESCRIPTION	EACH	5/EA
A02950-0001	Thinner	\$8.72	\$7.85
A02950-0002	Iridescent Medium	8.72	7.85
A02950-0004	Frosted Medium	8.72	7.85



Pebeo™ Porcelaine 150

Paint them on any bakeable surface for a finish as hard as enamel! Available in more than 50 lightfast colors, these professional waterbased paints blend beautifully and thin with water or mediums. Apply on a heat-stable surface — porcelain, crockery, terracotta, ceramics — and bake in your home oven. Once fired, they're safe for the dishwasher and outdoor use. Colors can be assorted for quantity pricing.

Transparent, 1.5 oz (45 ml) Bottles

NUMBER	COLOR	EACH	5/EA
A02908-2263	Abyss Black	\$8.32	\$7.49
A02908-4913	Agate Orange	\$8.32	\$7.49
A02908-8133	Amber Brown	\$8.32	\$7.49
A02908-8323	Anthracite	\$8.32	\$7.49
A02908-9603	Bronze Green	\$8.32	\$7.49
A02908-3243	Coral Red	\$8.32	\$7.49
A02908-7053	Emerald	\$8.32	\$7.49
A02908-3743	Etruscan Red	\$8.32	\$7.49
A02908-3723	Garnet Red	\$8.32	\$7.49
A02908-6423	Lapis Blue	\$8.32	\$7.49
A02908-4753	Marseille Yellow	\$8.32	\$7.49
A02908-7943	Olivine Green	\$8.32	\$7.49
A02908-7963	Peridot Green	\$8.32	\$7.49
A02908-3373	Ruby Red	\$8.32	\$7.49
A02908-5293	Sapphire Blue	\$8.32	\$7.49
A02908-3083	Scarlet Red	\$8.32	\$7.49

Opaque, 1.5 oz (45 ml) Bottles

NUMBER	COLOR	EACH	5/EA
A02908-2193	Chalkboard Black	\$8.32	\$7.49
A02908-9003	Gold	\$8.32	\$7.49
A02908-2595	Grey	\$8.32	\$7.49
A02908-1043	Ivory	\$8.32	\$7.49
A02908-5793	Ming Blue	\$8.32	\$7.49
A02908-5913	Opaline Blue	\$8.32	\$7.49
A02908-3843	Opaline Pink	\$8.32	\$7.49
A02908-6163	Parma Violet	\$8.32	\$7.49
A02908-2573	Pewter	\$8.32	\$7.49
A02908-8305	Taupe	\$8.32	\$7.49
A02908-5113	Turquoise	\$8.32	\$7.49

Semi-Transparent, 1.5 oz (45 ml) Bottles

NUMBER	COLOR	EACH	5/EA
A02908-4943	Citrine Yellow	\$8.32	\$7.49
A02908-3733	Fuchsia	\$8.32	\$7.49
A02908-7933	Malachite	\$8.32	\$7.49
A02908-4963	Saffron	\$8.32	\$7.49

Pastel, 1.5 oz (45 ml) Bottles

NUMBER	COLOR	EACH	5/EA
A02908-3845	Copper Pink	\$8.32	\$7.49
A02908-4485	Daffodil	\$8.32	\$7.49
A02908-6045	Lavender	\$8.32	\$7.49
A02908-4555	Mango	\$8.32	\$7.49
A02908-5325	Pastel Blue	\$8.32	\$7.49
A02908-3065	Tender Pink	\$8.32	\$7.49
A02908-7025	Water Green	\$8.32	\$7.49

Shimmer, 1.5 oz (45 ml) Bottles

NUMBER	COLOR	EACH	5/EA
A02908-2623	Ash	\$8.32	\$7.49
A02908-8153	Bronze	\$8.32	\$7.49
A02908-8103	Chocolate	\$8.32	\$7.49
A02908-1095	Pearl White	\$8.32	\$7.49
A02908-5933	Petroleum	\$8.32	\$7.49
A02908-3063	Pink	\$8.32	\$7.49
A02908-9333	Silver	\$8.32	\$7.49

Outliners, 0.68 oz (20 ml) Tubes

NUMBER	COLOR	EACH	5/EA
A02908-8322	Anthracite Black	\$8.32	\$7.49
A02908-9602	Bronze	\$8.32	\$7.49
A02908-9502	Copper	\$8.32	\$7.49
A02908-3242	Coral	\$8.32	\$7.49
A02908-9002	Gold	\$8.32	\$7.49
A02908-4752	Marseille Yellow	\$8.32	\$7.49
A02908-4752	Ming Blue	\$8.32	\$7.49
A02908-5792	Pewter	\$8.32	\$7.49
A02908-3712			



Jacquard Piñata Colors Alcohol Inks

These highly pigmented inks are great for card making, fine art, stamping, and more. Use them on almost any non-porous surface, including glass, metal, and leather. Fast-drying. Indelible and moisture-resistant when dry. Colors can be assorted for quantity pricing.

4 oz (118 ml) Bottles

NUMBER	COLOR	EACH	3/EA
A02981-1504	Baja Blue	\$10.66	\$9.58
A02981-2004	Blanco Blanco	10.66	9.58
A02981-5394	Blue Violet	10.66	9.58
A02981-9054	Brass	10.66	9.58
A02981-1704	Burro Brown	10.66	9.58
A02981-1204	Calabaza Orange	10.66	9.58
A02981-1304	Chili Pepper	10.66	9.58
A02981-9504	Copper	10.66	9.58
A02981-4924	Coral	10.66	9.58
A02981-4094	Golden Yellow	10.66	9.58
A02981-1804	Havana Brown	10.66	9.58
A02981-5504	Lime Green	10.66	9.58
A02981-2104	Mantilla Black	10.66	9.58
A02981-6434	Passion Purple	10.66	9.58
A02981-1094	Pearl	10.66	9.58
A02981-3064	Pink	10.66	9.58
A02981-1604	Rainforest Green	10.66	9.58
A02981-9264	Rich Gold	10.66	9.58
A02981-3794	Sangria	10.66	9.58
A02981-3704	Santa Fe Red	10.66	9.58
A02981-5294	Sapphire Blue	10.66	9.58
A02981-1404	Senorita Magenta	10.66	9.58
A02981-1904	Shadow Grey	10.66	9.58
A02981-9304	Silver	10.66	9.58
A02981-4954	Sunbright Yellow	10.66	9.58
A02981-4634	Tangerine	10.66	9.58
A02981-5084	Teal	10.66	9.58

ArtResin Epoxy Resin Kits

ArtResin creates a gorgeous, high-gloss, durable finish. Designed specifically for creative projects, this crystal-clear resin is easy and safe to use. The topcoat is self-leveling and fully cures in 72 hours. Low-odor, non-flammable, and certified non-toxic. No VOCs or fumes. For kit contents and accessories, visit DickBlick.com.

NUMBER	SIZE	EACH
A01044-1008	8 oz (237 ml) Kit	\$29.68
A01044-1032	32 oz (946 ml) Kit	51.94
A01044-1001	Gallon (3.78 Liter) Kit	126.14

NEW! Colorberry Resin

Combine resin and hardener in a 1:1 ratio to create stunning resin artwork that cures to a glossy, crystal-clear finish. This high-viscosity, low odor formula stays where it's poured to prevent running and spreading when used with glitter. It offers maximum UV resistance.



NUMBER	SIZE	EACH
A03380-1090	16.9 oz (500 ml)	\$30.30
A03380-1100	33.8 oz (1000 ml)	47.27
A03380-1110	67.6 oz (2000 ml)	83.64
A03380-1120	169 oz (5000 ml)	168.49

Pebeo Gedeo Bio-Based Resins

These resins are made of two components — resin and hardener — to produce a non-yellowing, transparent, glossy finish. They can be applied as high-gloss coatings on finished works of various mediums.



Crystal Resin

NUMBER	SIZE	EACH
A01048-1004	150 ml	\$19.64
A01048-1003	300 ml (10.1 oz)	30.99
A01048-1075	750 ml	54.12
A01048-1005	45 ml	10.23

Glazing Resin

NUMBER	SIZE	EACH
A01048-1014	150 ml	\$27.13
A01048-1023	300 ml (10.1 oz)	51.07
A01048-1015	Discovery Kit	11.68

Pro Resin

NUMBER	SIZE	EACH
A01048-1013	3 Liter (101.4 oz)	\$172.75
A01048-1016	6 L	317.00

EnviroTex Lite

Use it to create a hard, high-gloss finish on tabletops, plaques, clocks, figurines, and more. Fully cures in 36 hours. 8 oz kit covers 2-3 sq ft. 16 oz kit covers 4-6 sq ft. 32 oz kit covers 8-16 sq ft. 64 oz kit covers 16-32 sq ft.

NUMBER	SIZE	EACH
A02918-1005	8 oz (237 ml) Kit	\$14.98
A02918-1006	16 oz (473 ml) Kit	24.69
A02918-1007	32 oz (946 ml) Kit	39.73
A02918-1064	64 oz (1.89 Liter) Kit	71.42

Clean-Up Solution — Formulated for use with Piñata Colors, this solution contains moisturizers that keep brushes and sponges soft and pliable.

NUMBER	SIZE	EACH	3/EA
A02981-1001	1 oz (30 ml)	\$3.74	\$3.35

Claro Extender — Mix this solution with Piñata Colors to slow drying time and increase transparency without diluting color strength.

NUMBER	SIZE	EACH	3/EA
A02981-1101	1 oz (30 ml)	\$3.74	\$3.35

Exciter Pack — 0.5 oz (15 ml) bottles of Baja Blue, Blanco Blanco, Calabaza Orange, Mantilla Black, Passion Purple, Rainforest Green, Rich Gold, Senorita Magenta, and Sunbright Yellow.

NUMBER	EACH	3/EA
A02981-1009	\$29.70	\$26.73

Jacquard Pearl-Ex Pigment Sets

Made from powdered mica, non-toxic Pearl-Ex Pigments bring a lustrous glow to viscous mediums such as oil and acrylic paints, gouache, varnish, wax, and paper pulp, as well as clay. Not intended for traditional paint making, they're ideal for collage and mixed media art, calligraphy, faux-finishing, sculpture, papermaking, printing, candlemaking, and pottery. They never rust or tarnish and exhibit extreme colorfastness and stability for interior, exterior, and archival applications. For set colors, visit DickBlick.com



Lefranc & Bourgeois Flashe Vinyl Paint

Extra-fine, vinyl-based paint dries evenly with intense coverage to a uniform, velvety matte finish. Highly pigmented, Flashe may be

diluted with water to create a range of results, from highly opaque to a transparent watercolor effect.

Use it indoors or out on canvas, paper, or walls, with brushes, paint guns, or sponges. Colors can be assorted for quantity pricing.

4.2 oz (125 ml) Jars

NUMBER	COLOR	EACH	6/EA
A00697-2021	Black	\$16.65	\$14.98
A00697-5941	Blue Ash	16.65	14.98
A00697-7251	Bright Green	16.65	14.98
A00697-8041	Burnt Sienna	16.65	14.98
A00697-8051	Burnt Umber	16.65	14.98
A00697-3151	Carmine Red	16.65	14.98
A00697-5811	Cerulean Blue Hue	16.65	14.98
A00697-5191	Cobalt Blue Hue	16.65	14.98
A00697-6891	Dioxazine Violet	16.65	14.98
A00697-5851	Fluorescent Blue	20.62	18.54
A00697-4831	Fluorescent Green	20.62	18.54
A00697-4561	Fluorescent Orange	20.62	18.54
A00697-3781	Fluorescent Red	20.62	18.54
A00697-3891	Fluorescent Rose	20.62	18.54
A00697-1491	Fluorescent White	20.62	18.54
A00697-4221	Fluorescent Yellow	20.62	18.54
A00697-5921	Hoggar Blue	16.65	14.98
A00697-1041	Ivory	16.65	14.98
A00697-4061	Lemon Yellow	16.65	14.98
A00697-7131	Light Green Earth	16.65	14.98
A00697-6512	Mineral Violet	34.70	31.23
A00697-4141	Naples Yellow Hue	16.65	14.98
A00697-2541	Neutral Gray	16.65	14.98
A00697-4511	Orange	16.65	14.98
A00697-3721	Oriental Red	16.65	14.98
A00697-2561	Payne's Gray	16.65	14.98
A00697-5211	Prussian Blue	16.65	14.98
A00697-8061	Raw Sienna	16.65	14.98
A00697-8071	Raw Umber	16.65	14.98
A00697-3731	Red Ochre	16.65	14.98
A00697-3281	Red Vermilion	16.65	14.98
A00697-3371	Ruby Red	16.65	14.98
A00697-5051	Royal Blue	16.65	14.98
A00697-4071	Sahara Yellow	16.65	14.98
A00697-8081	Sepia Brown	16.65	14.98
A00697-7331	Spring Green	16.65	14.98
A00697-5111	Turquoise Blue	16.65	14.98
A00697-5231	Ultramarine Blue	16.65	14.98
A00697-3981	Venetian Pink	16.65	14.98
A00697-7911	Verdaccio	16.65	14.98
A00697-7891	Veronese Green Shade	16.65	14.98
A00697-7881	Viridian Hue	16.65	14.98
A00697-1021	White	16.65	14.98
A00697-4041	Yellow Ochre	16.65	14.98

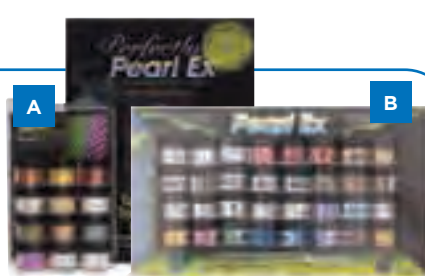

NUMBER	DESCRIPTION	EACH	6/EA
A27103-0039	A 6-Color Set	\$43.13	\$38.84
A27103-1129	12-Color Set & Free Book	34.39	30.94
A27103-2129	12-Color Set, Series II	34.39	30.94
A27103-3129	12-Color Set, Series III	34.39	30.94
A27103-1329	B 32-Color Set	80.09	72.08
A27103-1039	8-Color Chromatic Sampler Set	40.26	36.23

Calligraphy Set — The perfect introduction to making custom metallic inks for calligraphy. Set contains nine 0.1 oz (3 g) bottles of pigment, three 0.07 oz (2.25 g) jars of gum arabic, and instructions.

NUMBER	EACH	6/EA
A27103-1019	\$31.58	\$28.44



C Ronan Aquacote Bulletin Enamels

Perfect for painting floorcloths, furniture, murals, and so much more. These waterbased, high-gloss enamels can be used as finish coatings on interior/exterior vinyl, wood, fiberglass, metals, and many synthetics. They are lead-free, fast-drying, and weather-resistant. Colors can be assorted for quantity pricing.

COLOR	PINT (473 ML)	EACH	12/EA	QUART (946 ML)	EACH	12/EA
Black	A01026-2026	\$17.73	\$15.96	A01026-2027	\$29.55	\$26.60
Bright Red	A01026-3076	24.37	21.93	A01026-3077	40.52	36.47
Brilliant Blue	A01026-5066	24.84	22.35	A01026-5067	41.37	37.23
Clear Base Gloss	—	—	—	A01026-1607	30.41	27.37
Dark Green	A01026-7036	20.53	18.48	A01026-7037	34.28	30.85
Emerald	A01026-7056	20.53	18.48	A01026-7057	34.28	30.85
Fire Red	A01026-3116	23.75	21.38	A01026-3117	39.55	35.59
Imitation Gold	A01026-9046	20.53	18.48	A01026-9047	34.28	30.85
Ivory	A01026-1046	20.43	18.38	A01026-1047	33.96	30.57
Lemon Yellow	A01026-4066	23.11	20.80	A01026-4067	38.58	34.73
Light Blue	A01026-5026	23.75	21.38	A01026-5027	39.55	35.59
Magenta	A01026-3046	30.32	27.28	A01026-3047	50.51	45.46
Maroon	A01026-3346	29.67	26.70	A01026-3347	49.44	44.49
Medium Brown	A01026-8206	18.17	16.35	A01026-8207	30.20	27.18
Medium Orange	A01026-4526	23.98	21.58	A01026-4527	39.97	35.98
Primrose	A01026-4176	22.47	20.22	A01026-4177	37.50	33.75
Process Blue	A01026-5096	23.31	20.98	A01026-5097	38.79	34.92
Process Green	A01026-7406	22.79	20.51	A01026-7407	37.94	34.14
Process Purple	A01026-6016	34.08	30.67	A01026-6017	56.74	51.07
Reflex Blue	A01026-5416	25.26	22.73	A01026-5417	42.12	37.91
White	A01026-1016	19.78	17.80	A01026-1017	32.99	29.69
White White	A01026-1026	19.78	17.80	A01026-1027	32.99	29.69

D Bulls Eye 1-2-3 Latex Primer Sealer

Fast-drying, white-pigmented acrylic latex (water-thinnable) undercoat for all interior/exterior use. Can be used on chalky, weathered surfaces without washing and on glossy surfaces without sanding — even on damp surfaces because it lets moisture escape. Also adheres to galvanized metal. Soap-and-water cleanup. Any oil or latex paint can be applied over it. Dries in 60 minutes.

NUMBER	SIZE	EACH	6/EA
A01007-1007	Quart (946 ml)	\$16.90	\$15.21
A01007-1009	Gallon (3.78 Liter)	52.40	47.16

E Bulls Eye Spray Shellac

Durable, fast-drying, clear, protective finish. 12 oz (355 ml) can.

NUMBER	EACH	6/EA
A01011-1005	\$17.12	\$15.38



Famous 1-Shot Lettering Enamels

These oil-based, high-gloss enamel paints are the sign painter's best value for lettering work. For interior or exterior use on metal, glass, wood, or Masonite.

COLOR	4 oz (118 ML)	EACH	PINT (473 ML)	EACH
Aqua	A01016-5154	\$12.21	—	—
Black	A01016-2004	16.63	A01016-2006	\$27.08
Blue-Green	A01016-5604	12.21	A01016-5606	29.31
Bright Red	A01016-3074	21.30	A01016-3076	37.70
Brilliant Blue	A01016-5064	15.94	A01016-5066	28.85
Chamois	A01016-4104	12.21	—	—
Chrome Yellow	A01016-4154	17.70	A01016-4156	32.20
Coral	A01016-3244	17.70	—	—
Dark Blue	A01016-5034	12.21	A01016-5036	29.31
Dark Brown	A01016-8034	12.21	A01016-8036	29.31
Dark Green	A01016-7034	12.94	A01016-7036	28.39
Dark Magenta	A01016-3714	21.43	A01016-3716	44.16
Emerald Green	A01016-7054	12.94	A01016-7056	28.39
Fire Red	A01016-3114	19.89	A01016-3116	39.08
Imitation Gold	A01016-9044	12.94	A01016-9046	28.39
Ivory	A01016-1044	12.21	A01016-1046	29.31
Kansas City Teal	A01016-5084	12.21	—	—
Kool Crimson	A01016-3164	17.37	—	—
Lemon Yellow	A01016-4064	17.70	A01016-4066	32.20
Light Blue	A01016-5014	12.21	A01016-5016	29.31
Maroon	A01016-8164	17.37	A01016-8166	36.92
Medium Brown	A01016-8024	12.21	A01016-8026	29.31
Medium Gray	A01016-2524	12.21	A01016-2526	29.31
Medium Green	A01016-7024	12.94	A01016-7026	28.39
Metallic Brass	A01016-9054	31.59	A01016-9056	59.65

Chroma Acrylic Mural Paint

Ideal for outdoor art, this multipurpose acrylic paint is water-resistant, moisture-resistant, and lightfast. The opaque, ready-to-use colors are mixable and clean up



new!

NEW! Krylon® ColorMaxx® Spray Paint

Perfect for indoor and outdoor projects, quick-drying ColorMaster works on plastic, metal, wrought iron, wicker, glass, plaster, ceramic, and more. It offers exceptional durability, adhesion, and smoothness. Does not contain lead. Net weight varies. Colors can be assorted for quantity pricing.

12 oz (355 ml) Cans

NUMBER	COLOR	EACH	6/EA
A01405-8356	Almond	\$13.63	\$12.27
A01405-9366	Aluminum Metallic	13.63	12.27
A01405-5156	Bahama Sea	13.63	12.27
A01405-3046	Ballet Slipper	13.63	12.27
A01405-3706	Banner Red	13.63	12.27
A01405-5336	Blue Ocean Breeze	13.63	12.27
A01405-9046	Brauhaus Gold	13.63	12.27
A01405-3186	Burgundy	13.63	12.27
A01405-3446	Cherry Red	13.63	12.27
A01405-7896	Citrus Green	13.63	12.27
A01405-2926	Classic Gray	13.63	12.27
A01405-1116	Crystal Clear Flat	13.63	12.27
A01405-1076	Dover White	13.63	12.27
A01405-7046	Emerald Green	13.63	12.27
A01405-1946	Equestrian	13.63	12.27
A01405-2186	Flat Black	13.63	12.27
A01405-1136	Flat White	13.63	12.27
A01405-2176	Glossy Black	13.63	12.27
A01405-1186	Glossy White	13.63	12.27
A01405-8996	Gold Metallic	13.63	12.27
A01405-1086	Gum Drop	13.63	12.27
A01405-7496	Hunter Green	13.63	12.27
A01405-1106	Ivory	13.63	12.27

12 oz (355 ml) Cans

NUMBER	COLOR	EACH	6/EA
A01405-7166	Ivy Leaf	\$13.63	\$12.27
A01405-7926	Khaki	13.63	12.27
A01405-8906	Leather Brown	13.63	12.27
A01405-5186	Matte Aqua	13.63	12.27
A01405-8336	Matte Coffee Bean	13.63	12.27
A01405-2546	Matte Deep Gray	13.63	12.27
A01405-3786	Matte Eggplant	13.63	12.27
A01405-5576	Matte Glacier	13.63	12.27
A01405-8046	Matte Summer Wheat	13.63	12.27
A01405-4896	Matte Sunrise	13.63	12.27
A01405-1066	Matte White	13.63	12.27
A01405-5036	Navy Blue	13.63	12.27
A01405-5936	Peek A Boo Blue	13.63	12.27
A01405-2566	Pewter Gray	13.63	12.27
A01405-4616	Pumpkin Orange	13.63	12.27
A01405-6016	Purple	13.63	12.27
A01405-5716	Regal Blue	13.63	12.27
A01405-6166	Rich Plum	13.63	12.27
A01405-3196	Rose Gold Metallic	13.63	12.27
A01405-3076	Satin Ballet Slipper	13.63	12.27
A01405-2106	Satin Black	13.63	12.27
A01405-1126	Satin Bright White	13.63	12.27
A01405-8106	Satin Brown Boots	13.63	12.27
A01405-3186	Satin Burgundy	13.63	12.27
A01405-7526	Satin Hunter Green	13.63	12.27
A01405-4206	Satin Iris	13.63	12.27
A01405-2016	Satin Island Splash	13.63	12.27
A01405-7086	Satin Italian Olive	13.63	12.27
A01405-1206	Satin Ivory	13.63	12.27
A01405-4986	Satin Nickel Metallic	13.63	12.27
A01405-5106	Satin Oxford Blue	13.63	12.27
A01405-1426	Satin Pebble	13.63	12.27
A01405-7946	Satin Pistachio	13.63	12.27
A01405-7856	Satin Sea Glass	13.63	12.27
A01405-1646	Satin White	13.63	12.27
A01405-7026	Seaweed	13.63	12.27
A01405-2036	Semi-Gloss White	13.63	12.27
A01405-2556	Smoke Gray	13.63	12.27
A01405-4936	Sun Yellow	13.63	12.27
A01405-5276	True Blue	13.63	12.27
A01405-3766	Watermelon	13.63	12.27



A Krylon® Premium Metallic Spray Paint

Has a beautiful metallic finish that gives the appearance of actual metal plating, not paint. Spray it on wood, metal, wicker, glass, plaster, ceramic, fabric, paper, papier mâché, and more. Colors can be assorted for quantity pricing.

8 oz (236 ml) Cans

NUMBER	COLOR	EACH	6/EA
A01417-9015	18 kt Gold Plate	\$10.61	\$9.55
A01417-9505	Copper Brilliance	10.61	9.55
A01417-9515	Copper Foil	10.61	9.55
A01417-9025	Gold Foil	10.61	9.55
A01417-9115	Original Chrome	10.61	9.55
A01417-2585	Pewter Gray	10.61	9.55
A01417-9345	Silver Foil	10.61	9.55
A01417-9335	Sterling Silver	10.61	9.55
A01417-3725	Rose Gold	10.61	9.55

B Krylon® Make It Stone Spray Paint

Produces a stone-textured look. Start by applying Make It Stone paint, and then finish with Make It Last clear sealer (strongly recommended over metallic finishes). Colors can be assorted for quantity pricing.

12 oz (355 ml) Cans

NUMBER	COLOR	EACH	6/EA
A01400-2190	Black Granite	\$15.35	\$13.81
A01400-2130	Charcoal Sand	15.35	13.81
A01400-1010	Obsidian	15.35	13.81
A01400-8540	Travertine Tan	15.35	13.81
A01400-1020	White Onyx	15.35	13.81
A01400-1040	Clear Sealer, 6 oz	9.63	8.64

C Krylon® Chalky Finish Spray Paint

The ultra matte, chalk-like look will take your projects to new creative heights. It adheres well to metal, plastic, laminate, wood, glass, wicker, ceramic, and more with no primer or prep work needed. Durable, sandable, and safe for outdoor use, setting it apart from other chalk paint brands.

Colors can be assorted for quantity pricing.

12 oz (340 g) Cans

NUMBER	COLOR	EACH	6/EA
A01451-1040	Anvil Gray	\$14.22	\$12.82
A01451-1160	Bonnet Pink	14.22	12.82
A01451-1010	Classic White	14.22	12.82
A01451-1170	Clear Sealer	14.22	12.82
A01451-1080	Colonial Ivory	14.22	12.82
A01451-1190	Finish Wax Dark Brown	14.22	12.82
A01451-1180	Finish Wax Natural	14.22	12.82
A01451-1060	Mink	14.22	12.82
A01451-1020	Misty Gray	14.22	12.82
A01451-1100	Morning Sky	14.22	12.82
A01451-1050	Paver Gray	14.22	12.82
A01451-1070	Putty	14.22	12.82
A01451-1150	Scarlet	14.22	12.82
A01451-1030	Slate	14.22	12.82
A01451-1110	Tidal Blue	14.22	12.82
A01451-1090	Ultramarine	14.22	12.82
A01451-1120	Waterfall	14.22	12.82
A01451-1140	Wheat	14.22	12.82



D Montana™ White Spray Paints

High-covering, quick-drying gloss colors with excellent surface coverage. Made from a synthetic lacquer base, they're easy to use and deliver the performance and quality that artists have come to know and trust. High-pressure cans.

14 oz (400 ml) Cans

NUMBER	COLOR	EACH
A01430-1150	Arctica	\$8.29
A01430-1240	B-52	8.29
A01430-5040	Bavaria Blue	8.29
A01430-2020	Black	8.29
A01430-1090	Brazil	8.29
A01430-4500	Bright Orange	8.29
A01430-7910	Cactus	8.29
A01430-1170	Caipirinha	8.29
A01430-4510	Campari Orange	8.29
A01430-3920	Chili	8.29
A01430-1210	Dark Wave	8.29
A01430-4190	Desert	8.29
A01430-1250	Fall	8.29
A01430-6130	Fuchsia	8.29
A01430-7240	Grass Green	8.29
A01430-7250	Greenblack	8.29
A01430-5030	Heaven	8.29
A01430-3910	Hot Lips	8.29
A01430-1220	Ice Bear	8.29
A01430-1140	Kidney Beans	8.29
A01430-1080	King Kong	8.29
A01430-6190	Kings Purple	8.29
A01430-5020	Light Blue	8.29
A01430-1100	Lotus	8.29
A01430-1130	Lounge	8.29
A01430-1060	Malaria	8.29
A01430-1160	Monaco	8.29
A01430-2390	Nemo	8.29
A01430-1190	New Wave	8.29
A01430-5050	Night Blue	8.29
A01430-4040	Ochre	8.29
A01430-1110	Oldie	8.29
A01430-1120	Phantom	8.29
A01430-3190	Pig	8.29
A01430-1270	Plaster	8.29
A01430-2590	Rattlesnake	8.29
A01430-3900	Redblack	8.29
A01430-4280	Saffron	8.29
A01430-2290	Sea Breeze	8.29
A01430-9330	Silver	8.29
A01430-1180	Soap	8.29
A01430-1260	Squirrel	8.29
A01430-1230	Street	8.29
A01430-4400	Sunflower	8.29
A01430-4520	Sunset	8.29
A01430-6550	Sweet Violet	8.29
A01430-2490	Tropicana	8.29
A01430-2190	Viper	8.29
A01430-1200	Wave	8.29
A01430-1020	White	8.29
A01430-1070	Wild Willy	8.29

Montana™ Spray Caps

Caps can be used with any Montana can but are optimized for the Gold line.

NUMBER	DESCRIPTION	EACH	12/EA
A01428-7001	Level 1 Ultra Skinny	\$.49	\$.44
A01428-7002	Level 2 Fine Skinny	.49	.44
A01428-7003	Level 3 Skinny	.49	.44
A01428-7004	Level 4 Soft Fat	.49	.44
A01428-7005	Level 5 Fat	.49	.44
A01428-7006	Level 6 Ultra Fat	.49	.44

E Montana™ Black Spray Paints

The ultimate fast painting experience! Available in a range of vibrant colors, these high-pressure spray paints offer fast coverage for large areas.

14 oz (400 ml) Cans

NUMBER	COLOR	EACH
A01429-1250	Acid	\$9.87
A01429-1460	Ant	9.87
A01429-1220	Atlantis	9.87
A01429-1010	Atom's Megablast	9.87
A01429-5350	Baby Blue	9.87
A01429-2350	Beast	9.87
A01429-8140	Beige	9.87
A01429-2020	Black	9.87
A01429-3900	Bloody Mary	9.87
A01429-5140	Blue Lagoon	9.87
A01429-5990	Blue Velvet	9.87
A01429-1260	Boston	9.87
A01429-3230	Cardinal	9.87
A01429-3450	Cherry	9.87
A01429-8100	Chocolate	9.87
A01429-4590	Clockwork Orange	9.87
A01429-3790	Code Red	9.87
A01429-1280	Cool Cologne	9.87
A01429-9500	Copperchrome	9.87
A01429-5290	Dark Indigo	9.87
A01429-4910	Easter Yellow	9.87
A01429-3120	Fire Rose	9.87
A01429-2180	Fog	9.87
A01429-1320	Frappe	9.87
A01429-5910	Galaxy	9.87
A01429-9010	Goldchrome	9.87
A01429-1100	Halloween	9.87
A01429-5450	Horizon	9.87
A01429-5560	Ice Blue	9.87
A01429-1300	Iced Coffee	9.87
A01429-7730	Irish Green	9.87
A01429-4040	Juice	9.87
A01429-4920	Kicking Yellow	9.87
A01429-5900	Knock Out Blue	9.87
A01429-6040	Lavender	9.87
A01429-5020	Light Blue	9.87
A01429-1140	Lollipop	9.87
A01429-1090	Lost Island	9.87
A01429-3340	Maroon	9.87
A01429-3160	Miss Piggy	9.87
A01429-1160	Monster	9.87
A01429-1520	Morpheus	9.87
A01429-2590	Mouse	9.87
A01429-1150	Ms. Jackson	9.87
A01429-8930	Oasis	9.87
A01429-1410	Patina	9.87
A01429-6590	Pimp Violet	9.87
A01429-3150	Pink Cadillac	9.87
A01429-3140	Pink Panther	9.87
A01429-7090	Pistachio	9.87
A01429-5010	Power Blue	9.87
A01429-7010	Power Green	9.87
A01429-3060	Power Pink	9.87
A01429-3010	Power Red	9.87
A01429-6510	Power Violet	9.87
A01429-4030	Power Yellow	9.87
A01429-3130	Punk Pink	9.87
A01429-4600	Pure Orange	9.87
A01429-6110	Purple Rain	9.87
A01429-7110	Revolt Green	9.87
A01429-2580	Rhino	9.87
A01429-5050	Royal Blue	9.87
A01429-6410	Royal Purple	9.87
A01429-2220	Shark	9.87
A01429-9320	Silverchrome	9.87
A01429-7080	Slimer	9.87
A01429-1580	Snow White	9.87
A01429-1130	Sushi	9.87
A01429-1270	Tiffany	9.87
A01429-4300	Topaz	9.87
A01429-2370	Trout	9.87
A01429-5590	True Cyan	9.87
A01429-3040	True Magenta	9.87
A01429-4020	True Yellow	9.87
A01429-5230	Ultramarine	9.87
A01429-1180	Universe	9.87
A01429-1020	White	9.87
A01429-7240	Wild Lime	9.87
A01429-1170	Wizard	9.87
A01429-4010	Yellow	9.87

For more Montana™ Spray Paints, visit DickBlick.com.

F Montana™ Gold Acrylic Spray Paints

From very thin to super wide lines, Montana Gold paints are quick and easy to apply with accurate, professional results. A low-pressure system offers soft handling and smooth application.

14 oz (400 ml) Cans

NUMBER	COLOR	EACH
A01425-7130	Acid Green	\$11.92
A01425-8320	Anthraccite	11.92
A01425-5160	Aqua	11.92
A01425-2190	Asia	11.92
A		

adult aprons



A-B Blick® Adjustable Aprons

Durable, comfortable, and washable with an adjustable neck strap and a handy divided utility pocket. Choose from 26"L x 26"W poly/cotton twill, or 36"L x 25"W heavyweight washed denim.

NUMBER	DESCRIPTION	EACH	12/EA
A04992-1010	A Poly/Cotton	\$10.38	\$9.35
A04992-1020	B Denim	16.68	14.99

C Blick® Wheel Thrower's Apron

This lightweight, long-wearing, dark denim apron is crafted for comfort. Convenience features include a large 9" x 7" chest pocket, extra-long leg splits with calf ties, and an adjustable neck loop for proper fit. Machine-washable. 45"L x 29"W.

NUMBER	EACH	12/EA
A32948-5910	\$22.92	\$20.63

D White Apron

50% cotton/50% polyester apron for adults features a tie closure at the waist. Two large pockets on the front can hold supplies or your phone. Machine-washable. 35"L x 29"W.

NUMBER	EACH	12/EA
A03488-1025	\$11.53	\$10.38



E Denim Aprons

This 100% cotton denim apron for adults features a tie closure at the waist. Two front pockets are handy for holding supplies or phone. Hand wash in cold water.

NUMBER	SIZE	EACH	12/EA
A03489-5202	19" x 28"	\$7.70	\$6.93
A03489-5213	29" x 32"	11.55	10.40

F Vinyl Apron

This practical, 6 mil thick polyvinyl apron protects clothes from many common acids, alkalis, solvents, oils, grease, and paints. It has a long yoke neck with long waist ties. Light blue and transparent. 45"L x 35"W.

NUMBER	EACH	12/EA
A04981-5010	\$7.27	\$6.54

G-I Children's Art Aprons

Suitable for school or home projects.

For elementary grades — Made of quality, blue denim with stitched-on ties. 24"L x 18"W in front, with 8" overlap in the back.

NUMBER	DESCRIPTION	EACH	12/EA
A04927-5039	G Blue Denim	\$16.33	\$14.70

For older children, ages 8-14 — Made of quality, cloth-backed vinyl or blue denim with fully adjustable, stitched-on ties. 29"L x 17"W.

NUMBER	DESCRIPTION	EACH	12/EA
A04926-5051	H Vinyl	\$18.05	\$16.23
A04926-5031	I Blue Denim	13.49	12.14

J Children's Large Disposable Plastic Aprons

Disposal plastic aprons fit children ages 7 to 12 years old. Aprons measures 36" long. Each package contains 100 aprons in a dispenser bag.

NUMBER	EACH	10/EA
A04980-1020	\$20.22	\$18.19

K Sargent® Child's Smart Smock

Tyvek fabric breathes, unlike plastic or PVC smocks that allow heat buildup. Has an easy-to-use, hook-and-loop closure that can be worn in the front or back. 27" long. Light blue.

NUMBER	EACH	6/EA
A04800-1001	\$2.51	\$2.15

L Children's Apron

With its front hook-and-loop fastener, this kids' apron is easy to put on and take off. Made from 7 oz poly/cotton twill fabric. 19"L x 17"W.

NUMBER	EACH	12/EA
A04991-1010	\$9.44	\$8.53

children's aprons



Trimaco Stay Put Canvas Drop Cloth

Paint without worry. 300% more slip resistant than 8 oz canvas, this painter's drop cloth protects floors and stays put. It consists of two layers — absorbent canvas and a durable non-slip backing. Drop cloths with Spill Block have an added layer of plastic, so they're leak-resistant to all paints and stains.

NUMBER	SIZE	EACH
A04520-1044	4 ft x 4 ft	\$20.43
A04520-1168	6 ft x 8 ft w/Spill Block	45.97
A04520-2912	9 ft x 12 ft w/Spill Block	91.94



Trimaco SuperTuff Plastic Drop Cloth

This economical drop cloth is made with leak-resistant professional painter's plastic. It's embossed for easy opening. It can be used for covering floors, shrubbery, and furniture for dust containment. 9 ft x 12 ft and 1 mil thick.

NUMBER	EACH
A04519-1912	\$6.40



Sargent Art® Children's Art Smocks

Bright, colorful smocks help keep young artists clean. Smocks are made of water-resistant polyester with full sleeves and hook-and-loop closures for easy on and off. They have a full front and half back.

NUMBER	SIZE	EACH	
		SMALL	LARGE
A03485-1001	Small 17-1/2" x 13-1/2"	\$6.53	\$5.89
A03485-1101	Medium 21-1/2" x 17"	6.53	5.89
A03485-1201	Large 21-1/2" x 17-1/2"	6.53	5.89

Blick® Kids' Aprons

A colorful way to keep clothes clean. The small is 18"L x 14"W. The large is 25"L x 16"W. Made of polyester/cotton twill. Tie closures.

COLOR	SMALL		LARGE	
	NUMBER	EACH	NUMBER	EACH
Apple	A03406-7171	\$8.73	A03406-7172	\$9.82
Royal Blue	A03406-5061	7.85	A03406-5062	8.83
Tangerine	A03406-4561		A03406-4562	
Yellow	A03406-4021		A03406-4022	
	EACH	\$8.73	EACH	\$9.82
	12/EA	7.85	12/EA	8.83



Glovies® Disposable Gloves for Kids

Keep little hands clean! Made with waterproof plastic and designed just for kids, Glovies are latex-free, powder-free disposable gloves. Use them for finger painting, tie-dye, papier mâché, and other messy arts and crafts. When the fun is over, just remove the gloves and throw the mess away. For ages 2 to 9. Box of 100.

NUMBER	EACH
A03480-1001	\$14.19

Nitrile Powder-Free Disposable Gloves

Ideal for working with solvents, nitrile is chemical-resistant and helps dissipate electrostatic charges. These gloves are powder-free and allergen-free. Pack of 100.

NUMBER	SIZE	EACH	10/EA
A35200-1090	Small	\$34.99	\$31.49
A35200-1100	Medium	34.99	31.49
A35200-1110	Large	34.99	31.49
A35200-1120	X-Large	34.99	31.49



Latex-Powdered Disposable Gloves

Industrial-quality powdered natural rubber gloves deliver superb tactile sensitivity for complex tasks. pH-balanced; treated with absorbable dusting powder. Pack of 100.

NUMBER	SIZE	EACH	10/EA
A35200-1010	Small	\$18.33	\$16.50
A35200-1020	Medium	18.33	16.50
A35200-1030	Large	18.33	16.50
A35200-1040	X-Large	18.33	16.50



Neatness Mats

Durable, washable, and colorful too, Neatness Mats keep your work area clean and are marked with a 3/4" grid for convenient measuring and alignment of your projects. Flexible, waterproof, and resistant to glues and stains. Set of five includes Yellow, Red, Purple, Blue, and Green. Each measures 19-5/8" x 14-1/8".

NUMBER	DESCRIPTION	EACH	6/EA
A03469-1009	Set of 5	\$21.70	\$19.54

Kwik-Cover® Tablecloths

These custom-fit disposable table covers feature elastic sewn into the edges and self-sticking tape strips, so they're easy to place and remove — no cutting, taping, or tacking. The elastic molds to the outline of the table and the adhesive strips keep the tablecloth from slipping once in place. Reusable.

NUMBER	SIZE	EACH	25/EA
A04500-2472	24" x 72"	\$6.88	\$6.21
A04500-2496	24" x 96"	6.88	6.21
A04500-3072	30" x 72"	6.88	6.21
A04500-3096	30" x 96"	6.88	6.21
A04500-3672	36" x 72"	6.88	6.21
A04500-1048	48" Dia	6.88	6.21





Regular Wheel French Wheel



Pocket Size English Pocket Size Spanish



Watercolor Wheel

Artist Color Wheels

These important learning tools teach color mixing on one side and demonstrate color harmonies on the other.

NUMBER	DESCRIPTION	SIZE	EACH	12/EA
A04951-0000	Pocket	5-1/8"	\$3.80	\$3.38
A04915-1093	Regular	9-1/4"	6.85	6.23
A04954-0010	Watercolor Wheel	10"	9.40	8.39
A04915-1026	Big (not shown)	26"	44.72	40.25
A04915-2090	Spanish Version	9-1/4"	7.14	6.50
A04915-2050	Pocket Spanish	5-1/8"	3.99	3.61
A04915-1002	French Version	9-1/4"	7.14	6.50
A04915-1003	Pocket French	5-1/8"	3.99	3.61



Kolormondo 3-D Color Wheel

Great for students of all ages, this DIY kit includes five round pieces and six wedges — as you build it, learn how colors are related to each other and how each of the 570 colors flow from one to the other. Each piece of the globe teaches beginners about a different section of the color wheel. Small and lightweight, it has a 4-3/4" diameter.

NUMBER	EACH	12/EA
A03495-1004	\$11.78	\$10.60



Studio Color Wheel Poster

Color formulas have never been more picturesque! Based on the Ives Color Wheel, this large-format poster makes it easy to select the perfect combination of colors. The reverse side features a rich, textural collage of imagery. 28" x 28".

NUMBER	EACH	12/EA
A68465-1001	\$11.36	\$10.23

Create-A-Color™ Wheel

Use this set of black-and-white color wheels as a practical teaching tool for color mixing and color relationships. Each package includes four different color wheels to paint and two pages of instructions. Can be used with oil, acrylic, pastel, tempera, or watercolors. Pack of 10.

NUMBER	EACH	6/EA
A04914-1000	\$68.69	\$61.81



Richeson® Color Wheels

Front includes primary, secondary, and tertiary colors, as well as gray scales. Basic mixing instructions are supplied on the back for easy reference.

NUMBER	DESCRIPTION	SIZE	EACH	3/EA
A04601-1007	Class Pack of 30	7" Sqr	\$12.61	\$11.34
A04601-1019	Single Extra Large	19-1/2" Sqr	10.80	9.73



Gray Scale and Value Finder™

Place this die-cut card directly on a photo or artwork, or hold it between your eyes and your subject matter to match the gray values on the card to the colors you see. The 4" x 6" card displays 10 values, from 100% black to 10% black.

NUMBER	EACH	12/EA
A04947-2500	\$3.48	\$3.12



Studio

Magic Palette™ Color Selector & Mixing Guide

Mix colors like a pro! Handy guide shows you how to mix the colors you see based on actual tube color combinations. High-quality printing on a neutral gray background. Pocket size shows 18 colors and 324 hues. Studio size shows 29 colors and 841 hues.

NUMBER	DESCRIPTION	SIZE	EACH	6/EA
A03403-1010	Pocket	11-1/2" Sqr	\$11.99	\$10.80
A03403-1020	Studio	24" Sqr	30.21	27.18



7-3/4" Standard Wheel

Pocket Workbook

CMY Primary Mixing Wheel

The ever-popular CMY primary mixing wheel illustrates how the color spectrum is arranged, how complementary colors mix with each other, how colors mix with black and white, and color relationships and schemes. It's useful for all media including paints, dyes, and printing inks. The 26-page workbook includes a step-by-step guide to mixing colors and more.

NUMBER	DESCRIPTION	SIZE	EACH	12/EA
A04998-1020	Standard Wheel	7-3/4"	\$7.96	\$7.16
A04998-1040	Standard Workbook	7-3/4"	4.25	3.82
A04998-1050	Pocket Workbook	5-1/8"	2.72	2.45



12-1/4" x 4"

A

5" x 4-1/4"

B

C

D

A Plastic Palette Trays

Slanted mixing wells allow thinner or water to collect away from the paint.

NUMBER	SIZE	WELLS	EACH	12/EA
A03425-1005	5" x 4-1/4"	6	\$2.22	\$1.99
A03425-1045	4-1/2" x 7-1/2"	5	2.58	2.33
A03425-1009	4-1/2" x 7-1/2"	6	3.20	2.89
A03007-1008	12-1/4" x 4"	8	4.80	4.31

B Rectangular Plastic Palette

This easy-clean palette has both round and square wells (nine total) and an easy-grip thumbhole.

NUMBER	SIZE	EACH	12/EA
A03426-1875	11-3/4" x 8-3/4"	\$3.75	\$3.39

C Eldajon™ Palette

A favorite of watercolorists and students for many years. Made of heavy-duty, easy-to-clean, white plastic, it has three large mixing areas and 12 color wells.

NUMBER	SIZE	EACH	12/EA
A03015-1002	5-1/2" x 12"	\$7.42	\$6.69

D Plastic Tray Palette

This economical white plastic with seven wells and two mixing areas is ideal for young students.

NUMBER	SIZE	EACH	12/EA
A03086-1009	3-5/8" x 7-1/8"	\$1.15	\$9.99



E



F



G



H



I



J

E-G Mijello™ Peel-Off™ Palettes

Their high-impact plastic construction allows artists to simply peel away dried paints — even acrylics! Three choices: rectangular tray with a slight lip, two-piece airtight sealable case, or ergonomic, egg-shaped palette with thumbhole.

NUMBER	DESCRIPTION	EACH	6/EA
A03096-1040	E Tray	\$13.13	\$11.81
A03097-1040	F Dual Airtight	31.67	28.50
A03094-1021	G Ellipse Small	8.52	7.67

H Heavy-Duty Art Tray

Heavy-duty white plastic tray keeps painting and craft projects under control. For paints, soaking or marbling paper, clay projects, beadwork, or puzzles.

NUMBER	SIZE	EACH	12/EA
A03093-1001	10" x 12-1/2" x 1/2"	\$11.19	\$10.07
A03093-1003	13" x 18" x 1"	17.42	15.68

I Blick® Covered Palette

Recently redesigned, our covered palette is made of heavy-duty white plastic that's 20% thicker than before — the ideal accessory for watercolor or acrylic painters. 12" x 15" mixing area.

NUMBER	SIZE	EACH	12/EA
A03036-1002	12" x 15"	\$24.17	\$21.74



K



L

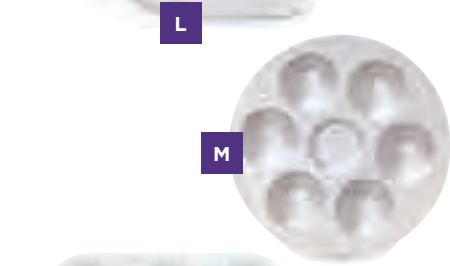

M



N



O

J Disposable Cups

Distribute paint, glue, beads, and more easily and economically with these disposable cups. A special lining makes them compatible with oil paints, too. Cups measure 1-1/16" deep x 2-3/16" Dia.

NUMBER	DESCRIPTION	EACH
A03317-0100	Pkg of 100	\$10.25
A03317-1000	Pkg of 1000	96.89
A03317-2100	Pkg of 100, colored	12.51

K-L Round Trays

NUMBER	DESCRIPTION	EACH	10/EA
A03041-1010	K Plastic Tray	\$1.01	\$8.88
A03041-1000	L Plastic Cover	1.18	1.05
A03068-1010	Plastic Tray and Cover	1.83	1.64

M 6-Well Tray, Aluminum — 5-3/8" Dia.

NUMBER	EACH	10/EA	20/EA
A03429-2706	\$3.57	\$3.21	\$3.05

N Rectangular Tray

A durable plastic tray with six circular wells for paint mixing.

NUMBER	SIZE	EACH	12/EA
A03068-1006	3-5/8" x 5-1/4"	\$.66	\$.59

O Blick® Folding Palette Box

The small box has five large mixing areas and 20 small paint wells. The large box has five large mixing areas and 24 paint wells. Both have hinged thumbholes and are deep enough to hold short-handled brushes and small paint tubes.

NUMBER	SIZE	EACH	12/EA	24/EA
A03001-0000	8" x 8"	\$5.58	\$4.99	\$4.75
A03001-0010	11-7/8" x 10-3/4"	8.21	7.34	6.99



A-F Masterson® Sta-Wet® Palettes and Palette Seal

Masterson offers a variety of easy ways to keep your paints fresh while working. These lightweight white plastic palettes are airtight when closed and clean up easily. The disposable palette film can be used for acrylics or oils. The sponge creates a damp atmosphere and keeps the acrylic film moist (remove for oils).

A Artist Palette Seal — Place your wet palette inside the Palette Seal and preserve your oils or acrylics in an absolutely airtight environment for days. The lid features built-in legs for holding the palette in place. Flexible, sturdy plastic. 12" x 16". Fits Premier Palette at right.

NUMBER	EACH	10/EA
A03020-0030	\$20.99	\$18.89

B Super Pro Palette — This 11-1/2" x 15-1/2" palette features a top side for watercolors and a bottom side for acrylics or oils. It includes one sponge insert and five sheets of acrylic film.

NUMBER	EACH	10/EA
A03020-0000	\$27.23	\$24.51

Refills for Super Pro Palette

NUMBER	DESCRIPTION	EACH	10/EA
A03020-0010	Acrylic Film, 30 Sheets	\$10.37	\$9.33
A03020-0040	Sponge Insert, 3-pack	13.05	11.74

C Handy Palette — Ideal for hobbyists and craft painters, this 8-1/2" x 7" palette includes one sponge insert and five sheets of palette paper.

NUMBER	EACH	10/EA
A03008-1002	\$12.83	\$11.78

Refills for Handy Palette

NUMBER	DESCRIPTION	EACH	10/EA
A03008-1009	Acrylic Film, 30 Sheets	\$5.73	\$5.16
A03008-1001	Sponge Insert, 3-pack	8.19	7.34



G-I Richeson® Lock Box

The Lock Box is a virtually airtight palette that maintains a moist environment for partially used watercolors, oils, or acrylics for days, even weeks. Made of strong, clear plastic, it measures 11-1/2"Dia. (Note: Some solvents may cause the plastic surface to craze.) The Disposable Paper Pad has 40 sheets of palette paper that are impervious to oil or water. Disposable Plastic Insert is lightweight plastic with 24 wells for watercolor painting. Acrylic Plastic Palette is 1/8" thick acrylic plastic and recommended for oil painting.

NUMBER	DESCRIPTION	EACH	10/EA
A03044-1040	G Box/Paper Pad	\$31.82	\$28.64
A03044-2024	H Box/24-Well Insert	25.99	23.41
A03044-1000	I Box/Acrylic Palette	39.54	35.59
A03044-2040	Paper Pad Only	19.14	17.23
A03044-1024	24-Well Plastic Insert Only	4.96	4.49
A03044-1001	Acrylic Plastic Palette Only	14.51	13.07
A03044-1005	Sponge 5-Pack	5.90	5.31
A03044-1006	Box with 6 Wells	26.30	23.66
A03044-2006	6-Well Only	5.53	4.99
A03044-1010	Box w/Insert & 10 Sheets	20.06	18.05



Mijello™ Fusion Watercolor Palettes

Lightweight, airtight, and leak-proof, with a tremendous amount of mixing space. High-impact plastic. 18 wells. 10-1/2" x 5".

NUMBER	DESCRIPTION	EACH	24/EA
A03095-4018	Blue 18 Well	\$22.08	\$19.87



Richeson® Neatness Jars & Tray

Six 8 oz unbreakable jars have no-spill, color-coded, flip-top lids and fit snugly in their heavy, white, vacuum-formed tray. The tray can also be used as a palette and measures 23-1/4" long.

NUMBER	EACH	3/EA
A04931-1009	\$23.61	\$21.23

Extra Jar with White Lid

NUMBER	EACH	3/EA
A04931-1005	\$2.64	\$2.37



12-Well Plastic Palette

Removable cups make this 12-well palette versatile and economical. Made from heavy-duty plastic, the palette has a large well for water and lids for the cups. 6" x 8".

NUMBER	EACH	6/EA
A03424-1012	\$8.21	\$7.40



Refill Storage Cups for 12-Well Plastic Palette

Great for storage of small items, these storage cups have lids that keep the contents secure and keep paint fresh.

NUMBER	DESCRIPTION	EACH	6/EA
A03327-1001	Pack of 12	\$4.89	\$4.39



J-Q Porcelain Palettes and Containers

Meet the studio heavyweights! Great for mixing paint (especially watercolor), these durable, long-lasting porcelain palettes and mixing trays won't stain or move around while in use. Easy to clean and store, they're a great value!

NUMBER	DESCRIPTION	EACH	12/EA
A03071-1003	J 11 Well Round	\$18.53	\$16.68
A03071-1001	K 5 Round/5 Slant	10.38	9.34
A03071-1002	L 7 Well Flower	8.82	7.93
A03071-1006	M 6 Large Nesting	24.47	22.04
A03071-1005	N 6 Small Nesting	20.98	18.88
A03071-1004	O 7 Well Round	18.53	16.68
A03071-1010	P 12 Well Round	18.56	16.70
A03071-1007	Q Brush Holder	9.05	8.14



Blick® Clear Acrylic Palette

A glassy-smooth surface of 1/8" thick acrylic plastic for oils, alkyds, or acrylics. Smoothly finished edges for a comfortable grip. Note: Use alcohol to remove dried-on acrylic paint, and mineral spirits or thinner to remove oils.

NUMBER	SIZE	EACH	10/EA	20/EA
A03028-1985	8-1/2" x 11"	\$14.57	\$13.11	\$12.45
A03028-1905	11" x 14"	17.86	16.38	15.60
A03028-1909	17" x 24"	33.36	30.03	28.52



Butcher Tray Palettes

Modeled after the original American butcher tray, these porcelain-enameled metal palettes have a convex center so water runs to the edges — perfect for dry brush techniques in watercolor or gouache. They clean easily and can last a lifetime. Inherent small rim chips will not affect performance.

NUMBER	SIZE	EACH	6/EA
A03066-1011	7-1/2" x 11"	\$13.48	\$12.15
A03066-1015	11" x 15"	20.07	18.04
A03066-1017	13" x 17"	27.53	24.77
A03066-1024	17" x 24"	38.99	35.11



Richeson® Multicolor Art Trays

Great for bead sorting, puzzle work, and many other art projects in the classroom. Durable heavy plastic cleans up easily. Set of five 15" x 10-1/2" trays, one each of Green, Purple, Yellow, Blue, and Red.

NUMBER	EACH	12/EA
A04512-1059	\$28.48	\$25.63



Richeson® Disposable Palette Paper Bulk Packs

These economically priced packs feature heavy 41 lb, low-density white paper, which is great for paint mixing. The specially coated palette paper is resistant to all types of paint and won't bleed through. Use what you need, then throw the mess away.

NUMBER	SIZE	SHEETS	EACH
A03513-1023	9" x 12"	2,500	\$162.08
A03513-1005	11" x 14"	1,400	179.52
A03513-1006	12" x 18"	1,400	232.86
AF03513-1009	18" x 24"	1,250	317.00



Blick® Studio Palette Paper Pads

Cleanup is quick and easy — just tear off a sheet, use it for your painting session, then throw it away! Great for use with acrylics, casein, and oils. 50-sheet pads.

NUMBER	SIZE	EACH	5/EA
A03063-2023	9" x 12"	\$7.15	\$6.45
A03063-2006	12" x 16"	9.90	8.91
A03063-2008	16" x 20"	19.95	17.95
A03063-2009	18" x 24"	22.25	19.99



Canson® Disposable Palette Pads

Specially treated heavy white paper for oils or acrylics. Tear off one sheet at a time and throw away the mess. 40-sheet, rigid-back pad.

NUMBER	SIZE	EACH	12/EA
A03011-1103	9" x 12"	\$7.26	\$6.53
A03011-1106	12" x 16"	12.83	11.54



Richeson® Grey Matters™ Paper Palette

Neutral, mid-tone gray paper palette is perfect for mixing accurate color values. Painter's guide on inside cover offers artists of all skill levels information on basic colors, mixing secondary colors, and complementary colors.

NUMBER	SIZE	SHEETS	EACH	10/EA
A03092-2569	6" x 9"	30	\$4.99	\$4.49
A03092-2523	9" x 12"	50	10.45	9.41
A03092-2506	12" x 16"	50	16.35	14.71
A03092-2508	16" x 20"	30	20.96	18.87

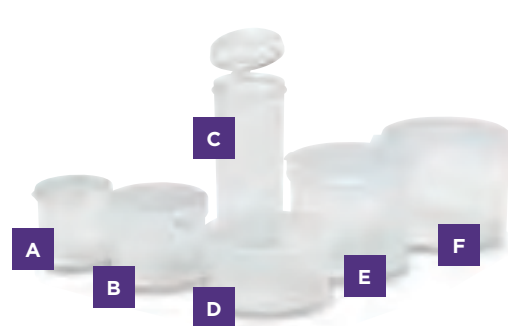

A-F LaCons® Hinged Lid Containers

These one-piece containers are made of food-grade clarified polypropylene. Featherlight, yet virtually unbreakable, they keep craft items, small parts, and paints neatly organized.

NUMBER	SIZE	EACH	24/EA
A04955-0003	A 1 oz (30 ml)	\$.99	\$ 9.1
A04955-0013	B 2 oz (60 ml)	1.07	.99
A04955-0005	C 2.5 oz (74 ml)	.91	.83
A04955-0000	D 3 oz (90 ml)	1.08	.99
A04955-0004	E 4 oz (120 ml)	1.07	.99
A04955-0014	F 5 oz (150 ml)	.99	.91

Sargent® No-Spill Paint Cups

The unique cap design keeps liquids inside if the cup tips over. The tabs on the easy-open lid won't break off with repeated use, and the inner rim recycles moisture to prevent evaporation. Grooves in the rim hold two brushes. Set of 10 cups in a reusable storage bag.

NUMBER	EACH	12/EA
A03326-1010	\$11.78	\$10.59



NEW! Blick Storage Cups

Made of transparent plastic for easy identification, cups feature snap-on lids to prevent evaporation and keep contents secure during transport.

Pkg of 12

NUMBER	SIZE	EACH	12/EA
A03390-1001	0.4 oz	\$3.95	\$3.55

Pkg of 8

NUMBER	SIZE	EACH	12/EA
A03390-1015	0.8 oz	\$3.62	\$3.25
A03390-1002	1.7 oz	4.28	3.85



Uline Plastic Cups and Lids, Pkg of 25

Disposable or reusable, these lightweight cups have airtight lids to prevent spillage and evaporation.

NUMBER	DESCRIPTION	EACH	50/EA
A03395-1023	2 oz	\$3.85	\$3.47
A03395-1024	4 oz	5.49	4.94



20 gauge, Pkg of 3

Fineline Precision Applicators

Perfect for accurate, controlled placement. Use them to draw complex, precise designs with your favorite liquid media. Non-clogging, airtight cap-and-wire system. Choose a container and either 18 gauge (0.8 mm) or 20 gauge (0.5 mm) applicator needles.

1 oz (30 ml) Tubes & Tips

NUMBER	DESCRIPTION	EACH
A03423-1118	18 gauge, Pkg of 3	\$14.25
A03423-1120	20 gauge, Pkg of 3	14.25
A03423-1018	18 gauge, Pkg of 2	10.87
A03423-1020	20 gauge, Pkg of 2	10.87
A03423-1001	20 gauge, Pkg of 3	9.78



Liquid Flow Dispenser

This see-through plastic container was designed for dispensing tempera or any other liquid. Tight-fitting cap makes it ideal for mixing and storing powdered tempera. 12 oz (355 ml) capacity with 1 oz (30 ml) graduations marked on the side.

NUMBER	EACH	12/EA
A03068-1001	\$2.99	\$2.69



Empty Paint Marker Dauber

This bottle's unique design and special tip help you paint without brushes or mess. Just fill with tempera paint and you're ready to create!

NUMBER	EACH	6/EA
A03324-1012	\$17.57	\$15.81



Empty Plastic Bottles

Easy, one-hand action when you need it most! Flexible poly bottles with lids that won't get lost. Package of 12.

NUMBER	SIZE	EACH	12/EA
A04993-1002	2 oz (60 ml)	\$11.70	\$10.53
A04993-1008	8 oz (237 ml)	11.70	10.53



5-Piece Funnel Set

Perfect for mixing and pouring craft materials, these white plastic funnels are durable and come in a useful range of sizes: 5-3/4"Dia, 4-3/4"Dia, 3-3/4"Dia, 2-3/4"Dia, and 1-3/4"Dia.

NUMBER	EACH	12/EA
A61420-0059	\$11.95	\$10.76

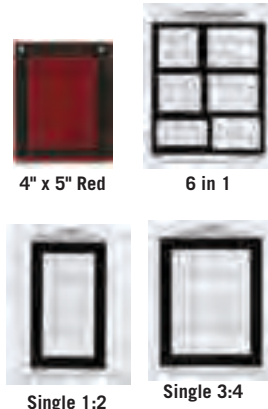

Compose It Grids With Value Finder

Solve any composition or perspective problem instantly! Using a dry-erase marker (not included), sketch your composition directly on the grid then use to transfer your sketch to canvas or pad. In eight proportional sizes, each grid lists the most common canvas and drawing pad sizes for that format. The red tinted value finder helps isolate light and shadow in a scene.

NUMBER	DESCRIPTION	EACH	12/EA
A03404-2981	4" x 5" Red, 3:4	\$14.50	\$13.05
A03404-1841	4" x 5" Clear, 3:4	14.50	13.05
A03404-1001	8" x 10", 6 in 1	20.51	18.46
A03404-1011	8" x 10" Single, 1:1	19.41	17.46
A03404-1012	8" x 10" Single, 1:2	19.41	17.46
A03404-1013	8" x 10" Single, 1:3	19.41	17.46
A03404-1023	8" x 10" Single, 2:3	19.41	17.46
A03404-1034	8" x 10" Single, 3:4	19.41	17.46
A03404-1045	8" x 10" Single, 4:5	19.41	17.46
A03404-1056	8" x 10" Single, 5:6	19.41	17.46
A03404-1057	8" x 10" Single, 5:7	19.41	17.46



No-Tip Water Pots

Featuring extra-wide bases, sturdy no-tip plastic water pots help eliminate spills. They're stackable for easy storage. 4"Dia x 3-3/4"H.

NUMBER	DESCRIPTION	EACH	12/EA
A03412-1006	Set of 6, Assorted Colors	\$23.65	\$21.28



ViewCatcher™

A must for every painter's utility kit, this handy, lightweight tool helps artists determine composition, crop images, and identify color values. The 3-1/2" x 3-1/2" ViewCatcher is constructed of neutral gray #5 durable plastic and has a small sight opening to aid in viewing "true" color. Adjust the window opening to help find the perfect composition, oriented horizontally, vertically, or in a square format. Five calibrations aid in finding that perfect proportion, 8" x 10", 8" x 12", 9" x 12", 11" x 14", and 12" x 16".

NUMBER	DESCRIPTION	EACH	6/EA
A04995-1000	Single ViewCatcher	\$10.70	\$9.63
A04995-1001	Pkg of 12	90.84	81.75



Empty Glass Bottle with Dropper Cap

Perfect for storing custom mixes of paint, dye, and other liquid art materials. Bottle holds 1 oz.

NUMBER	DESCRIPTION	EACH	12/EA
A22995-9996	Empty Bottle	\$1.38	\$1.24
A22995-9997	Dropper Cap	1.93	1.74
A22995-1012	Bottle with Dropper Cap	3.40	3.06



Tube Wringer

Get the most out of your paint investment with this ingeniously simple tool. It lets you actually squeeze out 30% more paint from tubes. By concentrating the contents of the tube, your paint or medium stays soft and ready to use, so there's less waste and tube breakage. Great for tubes up to 2-7/8" wide.

NUMBER	DESCRIPTION	EACH	12/EA
A04907-1000	Plastic	\$13.05	\$11.75
A04907-1000	Metal	28.34	25.50



QuickKomp™ Artist's Drawing Tool

This tool helps you render drawings with precision and accuracy, resulting in works that are in proportion and true-to-life. Lightweight, clear plastic tool measures 6-1/2"H x 8"L. Isolate a section of the scene in the grid window and visualize your composition in thirds, horizontally or vertically. Draw what you see in the QuickKomp grid window onto your gridded paper or canvas. The side of your QuickKomp can also be used as a straight edge.

NUMBER	EACH	12/EA
A04823-1065	\$11.28	\$10.14



Big Squeeze Tube Wringer

The Tube Wringer makes using all the paint in the tube easier, and it helps artists save money. The 3-1/8" gears fit most (if not all) metal, flexible plastic, and rigid plastic tubes. It's made from aluminum, zinc, and carbon steel.

NUMBER	EACH
A08955-5011	\$40.29



Miracle Sponge™

These compressed cellulose sponges expand in water. They can be torn or cut to any shape or size. Great for applying color to all sorts of fabrics and other surfaces, they're also good for general cleanup. 1/8" thick (when dry).

NUMBER	DESCRIPTION	EACH	3/EA
A60201-1002	3" x 4-1/4", Pkg of 4	\$9.71	\$8.83
A60201-1000	4" x 6", Pkg of 3	12.94	11.78
A60201-1001	8" x 11-1/4", Pkg of 2	21.09	19.19



Blick® Multi-Colored Painting Knife Set

This exclusive set of five handcrafted, black, anodized stainless steel blades comes with multi-colored ergonomic rubber handles for a comfortable grip. The set contains Blick's best selling shapes and sizes, including styles 20, 60, 62, 81, and 106.

NUMBER	EACH	12/EA
A03103-1059	\$57.60	\$51.85



Blick® Blue Comfort-Grip Painting Knives

Blick's revolutionary series of painting knives is made from black, anodized stainless steel with multicolored ergonomic rubber handles for cool looks and a comfortable grip. These knives are easy to clean and will provide years of dependable use.

NUMBER	STYLE	BLADE SIZE	EACH	6/EA	12/EA
A03103-1001	1	3/8" x 1-3/8"	\$12.36	\$11.13	\$10.49
A03103-1005	5	3/4" x 2-1/4"	12.36	11.13	10.49
A03103-1010	10	3/4" x 2-1/2"	12.36	11.13	10.49
A03103-1031	31	1-1/4" x 3-3/8"	12.36	11.13	10.49
A03103-1050	50	5/8" x 2-7/8"	12.36	11.13	10.49
A03103-1062	62	7/8" x 2-7/8"	12.36	11.13	10.49

A Traditional Set of 6 — Styles 5, 10, 22, 31, 50, and 62.

NUMBER	EACH	3/EA	6/EA
A03103-1069	\$74.47	\$66.99	\$63.29

B Set of 6 — Styles 106, 84, 81, 96, 111, and 112.

NUMBER	EACH	3/EA	6/EA
A03103-1169	\$74.47	\$66.99	\$63.29

C Detail Set of 6 — Styles 1, 19, 20, 44, 60, and 61.

NUMBER	EACH	3/EA	6/EA
A03103-0069	\$74.47	\$66.99	\$63.29

Princeton™ Catalyst™ Contours

Similar to Catalyst Wedges, but made of solvent-resistant nylon. They include a convenient hanging hole.

NUMBER	DESCRIPTION	SIZE	EACH	12/EA
A03422-7021	Shape C-21	2" x 1"	\$6.05	\$5.44
A03422-7022	Shape C-22	2" x 1"	6.05	5.44
A03422-7023	Shape C-23	2" x 1"	6.05	5.44
A03422-7024	Shape C-24	2" x 1"	6.05	5.44
A03422-7561	Shape C-61	2" x 1"	6.05	5.44
A03422-7562	Shape C-62	2" x 1"	6.05	5.44
A03422-7563	Shape C-63	2" x 2"	6.05	5.44
A03422-7564	Shape C-64	2" x 1"	6.05	5.44
A03422-8381	Shape C-81	2" x 2"	6.05	5.44
A03422-8382	Shape C-82	2" x 2"	6.05	5.44
A03422-8383	Shape C-83	2" x 2"	6.05	5.44
A03422-8384	Shape C-84	2" x 2"	6.05	5.44



Princeton™ Catalyst™ Wedges

Ergonomically designed to fit in the palm of your hand, Catalyst Wedges are at home with oils, acrylics, water-mixable oils, encaustics, plaster, clay, and even frosting. Crafted from flexible, FDA-approved silicone.

NUMBER	DESCRIPTION	SIZE	EACH	12/EA
A03422-1001	Shape 1	4" x 3"	\$9.56	\$8.61
A03422-1002	Shape 2	4" x 2"	9.56	8.61
A03422-1003	Shape 3	4" x 2"	9.56	8.61
A03422-1004	Shape 4	4" x 2"	9.56	8.61
A03422-1005	Shape 5	4" x 2"	9.56	8.61
A03422-1006	Shape 6	4" x 2"	9.56	8.61



Princeton™ Catalyst™ Blades

Not quite a brush. Not quite a palette knife. Catalyst Blades are crafted from flexible silicone to give artists new tools for expression. Great with heavy-bodied paints such as oils, acrylics, and water mixable oils. Because they are heat-resistant, they excel with encaustics. Artists are using them with plaster, clay, and even frosting.

NUMBER	DESCRIPTION	SIZE	EACH	12/EA
A06421-3151	Shape 1	1/2" x 1"	\$12.59	\$11.33
A06421-3152	Shape 2	1/2" x 1"	12.59	11.33
A06421-3153	Shape 3	1/2" x 1"	12.59	11.33
A06421-3154	Shape 4	1/2" x 1"	12.59	11.33
A06421-3155	Shape 5	1/2" x 1"	12.59	11.33
A06421-3156	Shape 6	1/2" x 1"	12.59	11.33
A06421-3301	Shape 1	1" x 2"	16.16	14.54
A06421-3302	Shape 2	1" x 2"	16.16	14.54
A06421-3303	Shape 3	1" x 2"	16.16	14.54
A06421-3304	Shape 4	1" x 2"	16.16	14.54
A06421-3305	Shape 5	1" x 2"	16.16	14.54
A06421-3306	Shape 6	1" x 2"	16.16	14.54
A06421-3501	Shape 1	2" x 2"	19.35	17.42
A06421-3502	Shape 2	2" x 2"	19.35	17.42
A06421-3503	Shape 3	2" x 2"	19.35	17.42
A06421-3504	Shape 4	2" x 2"	19.35	17.42
A06421-3505	Shape 5	2" x 2"	19.35	17.42
A06421-3506	Shape 6	2" x 2"	19.35	17.42

BLICK® painting knives

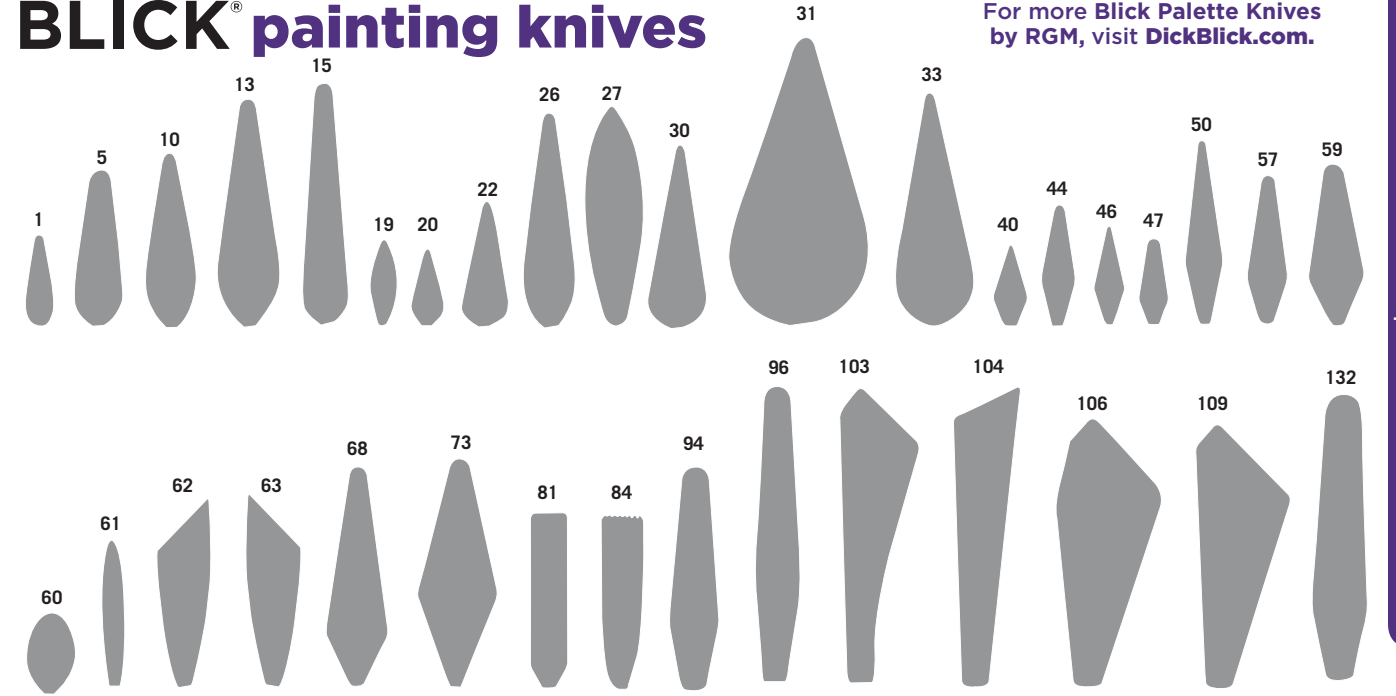

For more Blick Palette Knives by RGM, visit DickBlick.com.



Blick® Palette Knife

Tapered, 3" steel blade of extra-flexible tool metal. Long, balanced wooden handle.

NUMBER	EACH	12/EA	24/EA
A03115-1003	\$5.34	\$4.80	\$4.55



Blick® Palette Knives by RGM®

Made exclusively for Blick in Italy by RGM. Mix and manipulate textures using these versatile and beautifully crafted knives. Their steel blades are tempered and ground by hand for consistent flexibility and quality, then firmly set in kotibe wood handles using solid brass ferrules.

NUMBER	STYLE	BLADE SIZE	EACH	6/EA	12/EA	NUMBER	STYLE	BLADE SIZE	EACH	6/EA	12/EA
A03117-1001	1	3/8" x 1-3/8"	\$9.70	\$8.73	\$8.29	A03117-1057	57	5/8" x 2-3/8"	\$9.70	\$8.73	\$8.29
A03117-1005	5	3/4" x 2-1/4"	9.70	8.73	8.29	A03117-1059	59	7/8" x 2-5/8"	9.70	8.73	8.29
A03117-1010	10	3/4" x 2-1/2"	9.70	8.73	8.29	A03117-1060	60	7/8" x 1-1/2"	9.70	8.73	8.29
A03117-1013	13	7/8" x 3-1/4"	9.70	8.73	8.29	A03117-1061	61	1/4" x 2-1/8"	9.70	8.73	8.29
A03117-1015	15	3/4" x 3-1/2"	9.70	8.73	8.29	A03117-1062	62	7/8" x 2-7/8"	9.70	8.73	8.29
A03117-1019	19	3/8" x 1-1/8"	9.70	8.73	8.29	A03117-1063	63	7/8" x 2-7/8"	9.70	8.73	8.29
A03117-1020	20	1/2" x 1-1/8"	9.70	8.73	8.29	A03117-1068	68	7/8" x 3-1/4"	9.70	8.73	8.29
A03117-1022	22	3/4" x 2"	9.70	8.73	8.29	A03117-1073	73	1-1/8" x 3-3/8"	9.70	8.73	8.29
A03117-1026	26	3/4" x 3-1/8"	9.70	8.73	8.29	A03117-1081	81	1/2" x 2-7/16"	9.70	8.73	8.29
A03117-1027	27	7/8" x 3-1/8"	9.70	8.73	8.29	A03117-1084	84	3/4" x 2-3/8"	9.70	8.73	8.29
A03117-1030	30	7/8" x 3-3/8"	9.70	8.73	8.29	A03117-1094	94	5/8" x 2-3/8"	9.70	8.73	8.29
A03117-1031	31	1-1/4" x 3-3/8"	9.70	8.73	8.29	A03117-1096	96	3/4" x 3-1/4"	9.70	8.73	8.29
A03117-1033	33	1-1/8" x 3-3/8"	9.70	8.73	8.29	A03117-1103	103	1" x 3-3/4"	9.70	8.73	8.29
A03117-1040	40	1/2" x 1-1/8"	9.70	8.73	8.29	A03117-1104	104	7/8" x 4-1/4"	9.70	8.73	8.29
A03117-1044	44	1/2" x 1-7/8"	9.70	8.73	8.29	A03117-1106	106	1-5/8" x 4"	9.70	8.73	8.29
A03117-1046	46	5/8" x 2"	9.70	8.73	8.29	A03117-1109	109	1-3/8" x 3-7/8"	9.70	8.73	8.29
A03117-1047	47	1/2" x 1-1/4"	9.70	8.73	8.29	A03117-1132	132	3/4" x 4"	9.70	8.73	8.29
A03117-1050	50	5/8" x 2-7/8"	9.70	8.73	8.29						



Traditional Set of 3



Starter Set of 3



Traditional Set of 6



Spatula Set of 6



Detail Set of 6

Blick® Palette Knife Sets by RGM®

Made exclusively for Blick in Italy by RGM. Same fabrication as open stock knives above.

Traditional Set of 3 — Styles 22, 103, 132.

NUMBER	EACH	6/EA	12/EA
A03117-0169	\$20.52	\$18.47	\$17.55

Starter Set of 3 — Styles 5, 50, 96.

NUMBER	EACH	6/EA	12/EA
A03117-0269	\$20.52	\$18.47	\$17.55

Traditional Set of 6 — Styles 5, 10, 22, 33, 50, 62.

NUMBER	EACH	3/EA	6/EA
A03117-0069	\$48.83	\$43.95	\$41.75

Spatula Set of 6 — Styles 81, 84, 96, 106, 111, 112.

NUMBER	EACH	3/EA	6/EA
A03117-1069	\$48.83	\$43.95	\$41.75

Detail Set of 6 — Styles 1, 19, 20, 44, 60, 61.

NUMBER	EACH	3/EA	6/EA
A03117-2069	\$48.83	\$43.95	\$41.75



A-E Richeson® Plastic Painting Knives

Safer to use than metal knives, these one-piece molded plastic knives are also more economical, more durable, and easier to clean.

NUMBER	DESCRIPTION	EACH	12/EA	24/EA
A03105-0020	A Large Painting Knife	\$2.29	\$2.10	\$1.80
A03105-0000	B 2-3/8" Trowel Offset	2.29	2.10	1.80
A03105-1002	C 2" Diamond Trowel	2.29	2.10	1.80
A03105-0010	D 3-3/4" Straight	2.29	2.10	1.80
A03105-1003	E 3" Trowel Offset	2.29	2.10	1.80

Set of 5 — One of each shape above.

NUMBER	EACH	12/EA	24/EA
A03105-1059	\$10.65	\$9.58	\$9.10

Canister of 60, Assorted Shapes — 20 each of 3-3/4" Straight, 2" Diamond Trowel, and 2-3/8" Trowel Offset.

NUMBER	EACH	6/EA	12/EA
A03105-1009	\$73.54	\$66.19	\$62.88

F Canister of 60, Large Painting Knives — 60 of the popular "Scotty" shape.

NUMBER	EACH	6/EA	12/EA
A03105-1060	\$73.54	\$66.19	\$62.88



Liquitex® Painting Knife Ring Sets

High-quality stainless steel blades enhance color mixing and resist wear.

Set of 4 Large — A handy ring holds #2, #6, #11, and #13 Large painting knives.

NUMBER	EACH
A03126-0009	\$36.26

Set of 6 Small — Includes #1, #5, #6, #12, #16, and #17 Small palette knives.

NUMBER	EACH
A03126-1019	\$22.04

Chartpak® Jumbo Plastic Painting Knife Sets

Molded from hard-wearing ABS plastic, these flexible, lightweight jumbo knives won't corrode or rust like traditional knives. Their neutral, off-white, non-glare tone enhances color-mixing capability with all paints and mediums. Solvent-safe and easy to clean. 10" long. For set contents, visit DickBlick.com.

NUMBER	DESCRIPTION	EACH
A03130-1006	Set of 6	\$16.12

Liquitex® Painting Knives

Remember the adage about "the right tool for the job"? Liquitex's range of 36 knives includes unique large sizes and shapes in addition to smaller, more traditional sizes and shapes so you'll always have the right tool. The high-quality stainless steel blades enhance color mixing and resist wear and corrosion, while the ergonomic wood handles fit comfortably in the hand.

Large Knives			
NUMBER	SIZE	EACH	6/EA
A03126-2001	1	\$12.08	\$10.87
A03126-2002	2	12.08	10.87
A03126-2003	3	12.08	10.87
A03126-2004	4	12.08	10.87
A03126-2005	5	12.08	10.87
A03126-2006	6	12.08	10.87
A03126-2007	7	12.08	10.87
A03126-2008	8	12.08	10.87
A03126-2009	9	12.08	10.87
A03126-2010	10	12.08	10.87
A03126-2011	11	12.08	10.87
A03126-2012	12	12.08	10.87
A03126-2013	13	12.08	10.87
A03126-2014	14	12.08	10.87
A03126-2015	15	12.08	10.87
A03126-2016	16	12.08	10.87
A03126-2017	17	12.08	10.87
A03126-2018	18	12.08	10.87

Small Knives			
NUMBER	SIZE	EACH	6/EA
A03126-1001	1	\$4.83	\$4.35
A03126-1002	2	4.83	4.35
A03126-1003	3	4.83	4.35
A03126-1004	4	4.83	4.35
A03126-1005	5	4.83	4.35
A03126-1006	6	4.83	4.35
A03126-1007	7	4.83	4.35
A03126-1008	8	4.83	4.35
A03126-1009	9	4.83	4.35
A03126-1010	10	4.83	4.35
A03126-1011	11	4.83	4.35
A03126-1012	12	4.83	4.35
A03126-1013	13	4.83	4.35
A03126-1014	14	4.83	4.35
A03126-1015	15	4.83	4.35
A03126-1016	16	4.83	4.35
A03126-1017	17	4.83	4.35
A03126-1018	18	4.83	4.35



Paint Pipettes

A versatile tool for adding details to your artwork. Use for marbling, mixing colors, and applying inks, dyes, and liquid watercolor. Reusable. 6-1/4" long.

NUMBER	DESCRIPTION	EACH	6/EA
A06972-1025	Pkg of 25	\$9.29	\$8.34
A06972-1050	Pkg of 50	16.99	15.28

Sargent Art Paint Pipettes

Ideal for marbling and mixing colors, Paint Pipettes can also be used for applying inks, dyes, and liquid watercolor, as well as in blow-art activities. Each reusable plastic pipette holds 2.5 ml when filled up to the bulb. Use them to fill small bottles or transfer ink, stains, and other liquids from one container to another.

NUMBER	DESCRIPTION	EACH	6/EA
A03486-1012	Pkg of 12	\$4.49	\$3.99

Art & Hobby Swabs

Specifically designed and developed in strength and length for the 1001 uses in the art and hobby field. Approximately 6" long. Package of 100 swabs with wooden handles.

NUMBER	EACH	10/EA
A04826-1006	\$1.81	\$1.62

understanding natural hair brush shapes, types, and usage by shape

NAME/SHAPE	USAGE
Round 	Detail, wash, fills, thin to thick lines. MEDIA: All media HAIR: All hair, Synthetic
Full-Bellied Round 	Lettering, outlining, and long, continuous strokes. MEDIA: Watercolor, Ink, Decorative HAIR: Sable, Squirrel, Synthetic
Pointed Round 	Fine detailing, fine lines, spotting, and retouching. MEDIA: All media HAIR: Sable, Synthetic
Detail Round 	Detail painting, short strokes. MEDIA: Watercolor, Oil, Acrylic HAIR: Sable
Mottler 	Ideal for mop and wash techniques, for priming, and for area work. MEDIA: All media HAIR: Bristle, Ox, Squirrel, Badger, Synthetic
Mop/Wash 	Laying in large areas of water or color, wetting, absorbing. Note: Wash brushes come in several shapes, including Square (shown), Flat, and Oval. MEDIA: Watercolor HAIR: Bristle, Ox, Squirrel, Synthetic
Flat 	Bold, sweeping strokes; on edge for fine lines. Use heavier filling for heavier paint. MEDIA: All media HAIR: Sable, Bristle, Synthetic
Filbert 	Soft, rounded edges, blending, figurative work. MEDIA: Oil, Acrylic, Decorative HAIR: Sable, Bristle, Synthetic
Bright 	Short, controlled strokes. Useful with thick/heavy color. MEDIA: Oil, Acrylic, Decorative HAIR: Sable, Bristle, Synthetic
Fan 	Smoothing and blending, special effects, textures. MEDIA: Oil, Watercolor, Acrylic, Decorative HAIR: Bristle, Synthetic
Liner 	Lettering, highlighting, outlining, and long, continuous strokes. MEDIA: Watercolor, Ink, Decorative, Sign Paint HAIR: Sable, Ox, Synthetic
Angular Flat (Shader) 	Curved strokes, flower petals and leaves, filling in corners of squares and triangles. MEDIA: Watercolor, Acrylic, Decorative HAIR: Bristle, Synthetic

by hair



KOLINSKY SABLE is not really sable at all, but comes from the tail of a species of mink that is a member of the weasel family found in Siberia and northeastern China. It is generally conceded to be the best material for oil and watercolor brushes due to its strength, spring, and ability to retain its shape ("snap"). Long, fine hairs hold a very fine point/edge for precise control. Considered a professional grade of hair, Kolinsky will last for many years if properly cared for.



RED SABLE comes from any member of the weasel family with red hair — not from the animal known as the sable. It is found in a variety of brush styles for various mediums, with quality and characteristics that vary greatly. A good-quality pure red sable brush is a good alternative to the more expensive Kolinsky, with similar performance and durability. Often, weasel hair is blended with ox hair to make a more economical brush, but the fine point is sacrificed.

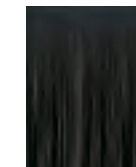

FITCH HAIR is a traditional, rare hair for oil painting that is similar to mongoose and sable. Fitch is super smooth, ideal for blending and portrait painting but (unlike sable), does not have fine hair tips. Sourced from Europe, fitch is a more affordable substitute for sable and great for detail.



OX HAIR The best quality ox hair comes from the ears of cattle or oxen. The hair has a very strong body, a silken texture, is very resilient, and has good "snap," but it lacks a fine tip. Therefore, it is most useful in medium-grade wash brushes or flat-shaped brushes. Frequently, ox hair is blended with other natural hair to increase the resiliency of a brush.

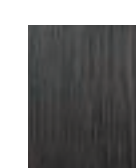

SQUIRREL HAIR Gray squirrel (Talahoutky), most highly in demand for lettering brushes and quills, is native to Russia and nearly always in short supply. Brown squirrel (Kazan) is more readily available, and used mainly for medium-quality and scholastic watercolor brushes. A very fine, thin hair taken from the squirrel's tail, it points as well as Kolinsky, but lacks Kolinsky's strength, stiffness, and "snap" (or memory). Because it has the best water-holding capacity of any natural hair brush, it works best with watercolor paints and inks.

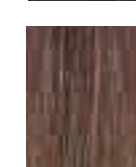

PONY HAIR The least strong of all the natural hair options, pony hair is primarily used in scholastic-grade brushes and more economical watercolor and touch-up brushes. Pony hair lacks "snap" (or memory) and will not return to a point after a brushstroke.



CAMEL HAIR does not actually come from camels. It is found in watercolor and lettering brushes and is usually made of goat, ox, or a blend of several hairs, depending on the desired softness and intended cost of the brush. Camel hair lacks "snap" (or memory) and will not return to a point after a brushstroke.



HOG BRISTLE Sourced from around the world, the most highly sought hog bristle comes from China. It is unlike other natural fillers in that it forms a V-shaped split or "flag" at the tip and tends to have a natural curve. A brush with "interlocked" bristles has a natural resistance to fraying and spreads medium to thick paints smoothly and evenly. A selection of pure hog bristle brushes is recommended for artists who work with oils and acrylics.



SYNTHETIC Developed to mimic the qualities and working properties of the best natural hair brushes, brushes made with synthetic fibers work well with a variety of media and techniques. Often blended with natural hair, the manmade filaments in these brushes can be stiff, firm, medium, or soft, rivaling natural hair in their performance.

BLICK® brush size chart

All Blick brushes are manufactured by hand to be uniform in size as represented by the charts below. The brush width is measured just above the ferrule and the sizes have been rounded to the nearest 1/32". Refer to these charts when choosing Blick brushes.

economy

scholastic

academic

studio

masterstroke

Round Brush Diameters



Flat, Bright, Filbert & Egbert Brush Widths



BLICK® brush canisters



Blick® Economy Golden Nylon **LONG** handle

Easier to clean than natural hair brushes and more durable for repeated classroom use, our Golden Nylon brushes are mounted on natural wood handles with a green gloss, lead-free finish, and seamless aluminum ferrules. Perfect for oil and acrylic. 40-Brush Flat Set: Sizes 1.0, 1/2, 1/4, and 3/4. 144-Brush Set: Rounds in Sizes 1, 2, and 4, and Flats in Sizes 1/2, 1/4, and 3/4. 60-Brush Set: Round in Size 6 and Flats in Sizes 1.0, 1/2, 1/4, and 3/4.

NUMBER	SET OF	EACH	6/EA
A06217-1040	40 Flat	\$187.10	\$168.39
A06218-1144	144 Asst	282.45	254.21
A06219-1060	60 Asst	249.82	224.83

Blick® Economy Golden Taklon **LONG** handle

An economical grade of Golden Taklon is a great choice for oils and acrylics because it withstands caustic solvents and acrylic paints better than animal hair. These synthetic brushes have natural wood handles in a green gloss finish and seamless, polished aluminum ferrules. Round assortment includes Sizes 0, 1, 2, 4, 6, 8, 10, and 12. Flat assortment includes Sizes 2, 4, 6, 8, 10, and 12.

NUMBER	SET OF	EACH	6/EA
A06216-1144	144 Rnd	\$249.82	\$224.83
A06222-1108	108 Flat	249.82	224.83

Blick® Economy Bristle Flats **LONG** handle

Extra-long white hog bristle fills these excellent-quality brushes. They are especially useful for beginning oil and acrylic painting because they are thick enough to push heavy paint around with ease. Each brush features a seamless polished aluminum ferrule and long, natural wood handle with a lead-free, green gloss finish. Assortment includes 144 Flats in Sizes 4, 6, 8, 12, 16, and 24.

NUMBER	SET OF	EACH	6/EA
A06221-1144		\$174.52	\$157.07

Blick® Economy Camel Rounds **SHORT** handle

These brushes deliver the superior paint-holding ability of natural hair at an unbeatable price. A popular choice for watercolor painting, each brush has a short, natural wood handle with a lead-free, green gloss finish. Sized just right for watercolor, tempera, or acrylic painting. 120-brush set includes Sizes 2, 4, 6, 8, and 10. 144-brush set includes Sizes 1, 2, 4, 6, 8, and 10.

NUMBER	SET OF	EACH	6/EA
A06220-1120	120	\$71.68	\$64.51
A06220-1144	144	97.75	87.97



Blick® Scholastic Red Sable Rounds **LONG** handle **SHORT** handle

Excellent craftsmanship at a price that brings a professional-quality brush within student reach. Red Sable hair offers snap and resiliency. Brushes feature natural wood handles with a blue gloss finish and seamless nickel-plated brass ferrules. These 72-brush (long handle) and 144-brush (short handle) assortments contain Sizes 0, 2, 4, 6, 8, and 10.

NUMBER	SET OF	EACH	6/EA
A06054-7209	72 Long Handle	\$222.55	\$200.29
A06054-1009	144 Short Handle	418.00	376.00



Blick® Scholastic Red Sable Flats **LONG** handle

Excellent quality and traditional craftsmanship make our Scholastic Red Sable a value that beginning or professional artists will appreciate. Offering snap and resiliency, they handle oils or acrylics beautifully. 72-brush assortment includes Flats in Sizes 0, 2, 4, 6, 8, and 10.

NUMBER	SET OF	EACH	6/EA
A06055-7209		\$191.45	\$172.30



Blick® Scholastic Natural Bristle **LONG** handle

Students will love the professional feel and results these brushes deliver. The hair is 100% hog bristle — an economical, high-performance hair ideal for spreading medium to thick paints smoothly and evenly. The natural wood handles have a blue gloss finish, with seamless polished nickel-plated brass ferrules. 72-Brush assortment contains 12 each Round and Flat in Sizes 8, 10, and 12. Round and Flat assortments include 12 each in Sizes 8, 10, and 12.

NUMBER	SET OF	EACH	6/EA
A06056-7209	72 Asst	\$210.85	\$189.77
A06057-3609	36 Round	143.28	128.95
A06058-3609	36 Flat	168.57	151.72



Blick® Scholastic Wonder White Rounds **SHORT** handle

Blick's White Taklon delivers the texture and responsiveness of Red Sable, yet holds up to the caustic nature of solvents and acrylic paints with greater durability, making these brushes a must-have for the classroom. The sharp point has good spring. Short handles are finished in blue gloss with nickel-plated brass ferrules. Assortment of 144 Round brushes in Sizes 0, 1, 2, 4, 6, and 8.

NUMBER	EACH	6/EA
A06053-1009	\$365.00	\$328.00

BLICK® essentials value brush sets

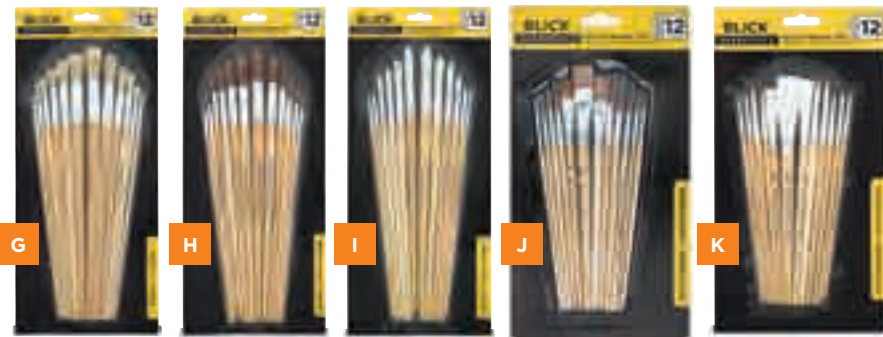

A-O Blick® Essentials Value Brush Sets

Whatever your style, skill level, or choice of media, there's a Blick Essentials Value Brush Set that's right for the task. These affordable brush sets are great for all types of artists — students, beginners, and the price-conscious professional. For set contents, visit DickBlick.com.

3-Piece Utility Brush Sets — Short Handle

NUMBER	DESCRIPTION	EACH	12/EA
A06280-1019	A Bristle	\$5.80	\$5.22
A06280-1009	B Brown Nylon	5.80	5.22
A06280-1029	C White Nylon	5.80	5.22

12-Piece Flat Brush Sets — Long Handle

NUMBER	DESCRIPTION	EACH	12/EA
A06280-1129	D Bristle	\$9.03	\$8.12
A06280-1119	E Brown Nylon	14.68	13.22
A06280-1109	F White Nylon	14.68	13.22

12-Piece Round Brush Sets — Long Handle

NUMBER	DESCRIPTION	EACH	12/EA
A06280-1159	G Bristle	\$9.03	\$8.12
A06280-1149	H Brown Nylon	14.68	13.22
A06280-1139	I White Nylon	14.68	13.22

12-Piece Assorted Brush Sets — Short Handle

NUMBER	DESCRIPTION	EACH	12/EA
A06280-1269	J Brown Nylon	\$10.55	\$9.50
A06280-1259	K White Nylon	10.55	9.50

25-Piece Craft Brush Set — Ideal for craft and fine art use, this set includes a variety of sizes, shapes, and brush hairs for acrylics, oils, watercolors, and other media. Perfect for beginning artists, students, and professionals.

NUMBER	DESCRIPTION	EACH	12/EA
A06280-1309	L	\$10.68	\$9.62

Foam Brush Sets

NUMBER	DESCRIPTION	EACH	12/EA
A06280-1409	M 3-Piece	\$1.78	\$1.60
A06280-1319	N 25-Piece	7.95	7.15

5-Piece Palette Knife Set — This affordable palette knife set contains five lightweight, reusable plastic painting knives ideal for mixing colors and impasto painting techniques.

NUMBER	DESCRIPTION	EACH	12/EA
A02820-1059	N O	\$4.99	\$4.49

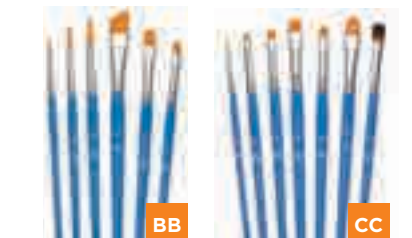
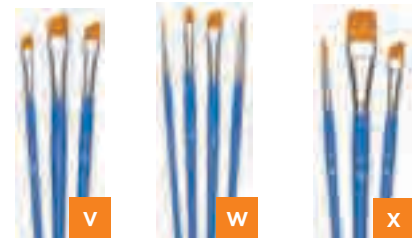
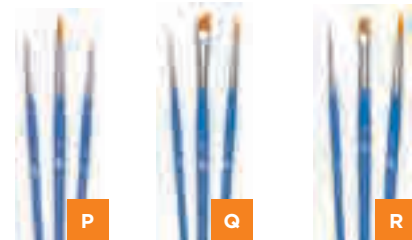

P-CC Princeton™ Select Value Sets

This brush line goes beyond the basic shapes and sizes, adding exciting technique brushes such as Lunar Blenders and Filbert Grainers. Every brush is handcrafted and tested to ensure beautifully consistent performance. These sets are an incredible value, priced much lower than if individual brushes were purchased to form a set. Each set contains a range of essential brush shapes and sizes. For set contents, visit DickBlick.com.

NUMBER	DESCRIPTION	EACH	3/EA
A06445-1019	P Set 1, Set of 3	\$7.78	\$6.99
A06445-1029	Q Set 2, Set of 3	7.78	6.99
A06445-1039	R Set 3, Set of 3	7.78	6.99
A06445-1049	S Set 4, Set of 3	7.78	6.99
A06445-1009	T Set 10, Set of 5	15.65	14.08
A06445-1109	U Set 11, Set of 4	15.65	14.08
A06445-1209	V Set 12, Set of 3	15.65	14.08
A06445-1309	W Set 13, Set of 4	15.65	14.08
A06445-1409	X Set 14, Set of 3	15.65	14.08
A06445-1509	Y Set 15, Set of 5	15.65	14.08
A06445-2009	Z Set 20, Set of 6	23.47	21.13
A06445-2109	AA Set 21, Set of 6	23.47	21.13
A06445-2209	BB Set 22, Set of 6	23.47	21.13
A06445-2309	CC Set 23, Set of 7	23.47	21.13

A-TT Princeton™ RealValue™ Brush Sets

Princeton Art Brush Company's best-selling line of brush sets. They are ideal for all types of art-making. Choose natural, synthetic, or combination sets that contain a variety of shapes and sizes in short-handled and long-handled styles. For great quality at an affordable price, choose RealValue!

Short Handle

NUMBER	DESCRIPTION	EACH	6/EA
A06223-9100	A Synthetic Pony, Set of 3	\$3.82	\$3.43
A06223-9101	B Synthetic Pony, Set of 3	3.82	3.43
A06223-9103	C Bristle, Set of 3	3.82	3.43
A06223-9104	D Bristle, Set of 3	3.82	3.43
A06223-9105	E Synthetic Sable, Set of 3	3.82	3.43
A06223-9110	F Synthetic Pony, Set of 4	5.13	4.62
A06223-9112	G Bristle, Set of 4	5.13	4.62
A06223-9115	H Golden Taklon, Set of 4	5.13	4.62
A06223-9116	I Golden Taklon, Set of 4	5.13	4.62
A06223-9117	J White Taklon, Set of 4	5.13	4.62
A06223-9170	K Golden Taklon, Set of 5	7.25	6.53
A06223-9171	L Golden Taklon, Set of 4	7.25	6.53
A06223-9172	M Golden Taklon, Set of 4	7.25	6.53
A06223-9173	N Golden Taklon, Set of 4	7.25	6.53
A06223-9174	O White Taklon, Set of 5	7.25	6.53
A06223-9180	P Stencil, Set of 4	8.09	7.28
A06223-9181	Q Golden Taklon, Set of 4	8.09	7.28
A06223-9182	R White Taklon Set of 4	8.09	7.28
A06223-9183	S Bristle, Set of 4	8.09	7.28
A06223-9184	T Golden Taklon, Set of 5	8.09	7.28
A06223-9120	U White Taklon, Set of 4	9.20	8.28
A06223-9121	V Synthetic Pony, Set of 4	9.20	8.28
A06223-9122	W Synthetic Pony, Set of 3	9.20	8.28
A06223-9123	X Golden Taklon, Set of 4	9.20	8.28
A06223-9125	Y White Taklon, Set of 4	9.20	8.28
A06223-9132	Z Golden Taklon, Set of 6	11.12	9.99
A06223-9133	AA Golden Taklon, Set of 6	11.12	9.99
A06223-9136	BB White Taklon, Set of 5	11.12	9.99
A06223-9137	CC Golden Taklon, Set of 6	11.12	9.99
A06223-9139	DD Golden Taklon, Set of 5	11.12	9.99
A06223-9140	EE White Taklon, Set of 6	12.78	11.50
A06223-9141	FF Golden Taklon, Set of 7	12.78	11.50
A06223-9143	GG Golden Taklon, Set of 7	12.78	11.50
A06223-9144	HH White Taklon, Set of 5	12.78	11.50
A06223-9146	II Golden Taklon, Set of 4	12.78	11.50
A06223-9151	JJ White Taklon, Set of 5	16.72	15.03
A06223-9152	KK White Taklon, Set of 5	16.72	15.03
A06223-9153	LL Golden Taklon, Set of 6	16.72	15.03

Long Handle

NUMBER	DESCRIPTION	EACH	6/EA
A06223-9118	MM Bristle, Set of 4	\$5.13	\$4.62
A06223-9130	NN White Taklon, Set of 4	11.12	9.99
A06223-9131	OO Bristle, Set of 4	11.12	9.99
A06223-9147	PP White Taklon, Set of 4	12.78	11.50
A06223-9148	QQ Combo, Set of 6	12.78	11.50
A06223-9154	RR Bristle, Set of 7	16.72	15.03
A06223-9155	SS White Taklon, Set of 5	16.72	15.03
A06223-9156	TT White Taklon, Set of 6	16.72	15.03

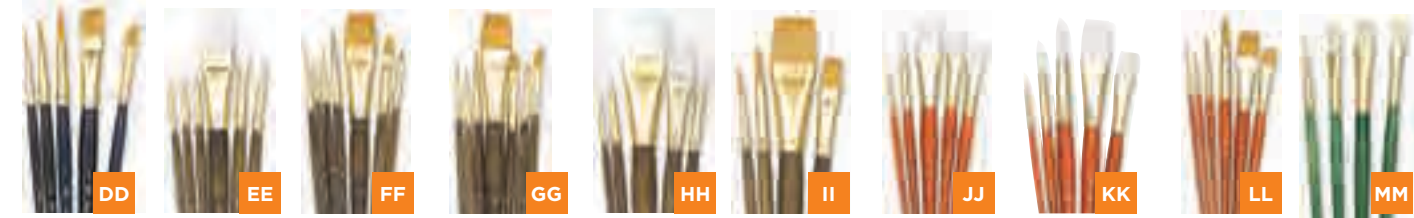
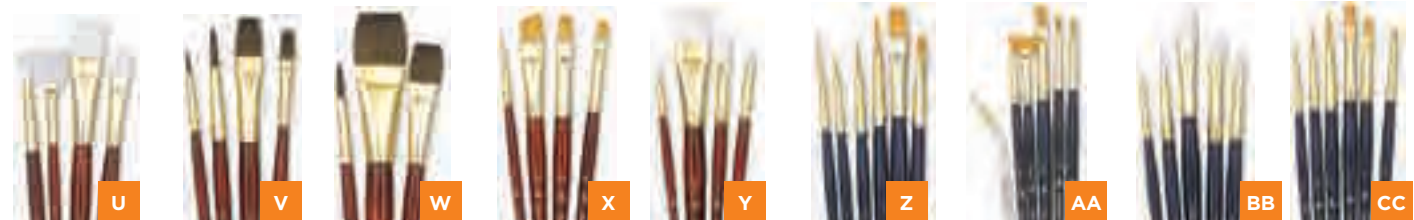



A



B



C



D



E



F



G



H



I



J



K



L

Royal & Langnickel® Big Kid's Choice™ Lil' Grippers Brush Sets

SHORT handle

Intended for young artists' hands, Lil' Grippers brushes have thicker handles and a rubber Soft Grip for easy handling. The synthetic brush fibers have been dyed to match the handles — kids will love the bright colors! Available in specially selected sets, Lil' Grippers are great for use with acrylics, tempera paints, watercolors, and more.

NUMBER	SET	EACH	12/EA
A06082-1749	A Set of 4, Fan	\$8.70	\$7.83
A06082-2059	B Set of 5, Angular	8.70	7.83
A06082-1859	C Set of 5, Filbert	8.70	7.83
A06082-2169	D Set of 6, Round	8.70	7.83
A06082-1649	E Set of 6, Shader	8.70	7.83
A06082-1669	F Set of 6, Deluxe	8.70	7.83
A06082-1049	G Set of 4, Beginner	5.50	4.97
A06082-1569	H Set of 4, Round and Flat	8.70	7.83
A06082-1259	I Set of 5, Fan Variety	8.70	7.83
A06082-1159	J Set of 5, Flat Variety	8.70	7.83
A06082-1449	K Set of 4, Angular and Filbert	8.70	7.83

L 15-Piece Variety Pack — Includes three Flat brushes (Sizes 3/4", 5/8", and 8), three Angular brushes (Sizes 3/4", 5/8", 3/8", and 1/4"), three Round brushes (Sizes 10, 6, and 4), two Filbert brushes (Sizes 3/4" and 4), a Size 1 Liner brush, a Size 1 Script Liner brush, and a Size 6 Fan brush.

NUMBER	EACH	12/EA
A06082-1509	\$15.88	\$14.28

12-Piece Sets — Great for when you need multiples of the same brush. Sets contain a dozen of the same size brush.

NUMBER	DESCRIPTION	SIZE	EACH	12/EA
A06082-1229	Round	2	\$23.75	\$21.39
A06082-1269	Round	6	23.75	21.39
A06082-1289	Round	8	23.75	21.39
A06082-2149	Flat	4	23.75	21.39
A06082-2189	Flat	8	23.75	21.39
A06082-2129	Flat	12	23.75	21.39

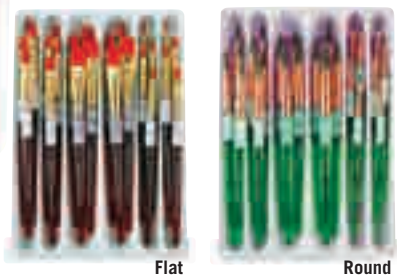

Flat

Round

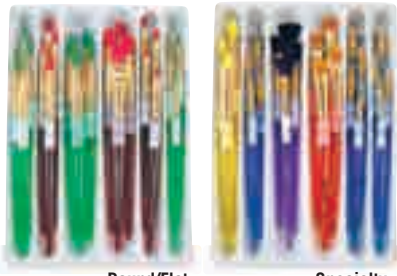

Round/Flat

Specialty

Royal & Langnickel® Big Kid's Choice™ 24-Piece Value Sets

These Taklon brushes with durable acrylic handles stand up to repeated use. Royal's Grippers technology gives kids extra gripping power and more control while they work. For waterbased media, these sets include a variety of shapes and sizes. For set contents, visit DickBlick.com.

NUMBER	DESCRIPTION	EACH	12/EA
A06085-1009	Flat	\$30.50	\$27.45
A06085-1019	Round	30.50	27.45
A06085-1029	Round/Flat	30.50	27.45
A06085-1039	Specialty	30.50	27.45



Round & Shader

Round

Flat

Specialty

Royal & Langnickel® Big Kid's Choice™ Class Packs

SHORT handle

These durable acrylic handle brushes with Taklon fibers stand up to repetitive use, and the extra gripping power is perfect for small hands. Perfect for young artists using waterbased media, there's no paint to flake off.

72-Brush Assortments — These 72-brush class packs include a variety of sizes and shapes, plus a drying/storage tray, and 18 bonus Aqua-Flo water brushes. For set contents, visit DickBlick.com.

NUMBER	DESCRIPTION	EACH	3/EA
A06031-0729	Round and Shader	\$113.12	\$101.80
A06031-1729	Round	113.12	101.80
A06031-2729	Specialty	113.12	101.80
A06031-0909	Flat	118.50	106.65
A06046-4072	Assorted	122.82	110.54

Set of 48 Jumbo — Twelve round sizes 10 and 16. Twelve flat sizes 12 and wash 3/4". Eighteen Aqua-Flo Brushes (6 each size, small, medium and large). One brush care tray

NUMBER	DESCRIPTION	EACH	3/EA
A06046-0489	Combo	\$102.79	\$92.50



Royal & Langnickel® Big Kid's Choice™ Chubby Brush Class Packs

SHORT handle

These durable 48-brush assortments features acrylic handles that are thicker for small hands to hold, and no paint to flake off! Choose soft, colorful synthetic fiber brushes or stiffer white hog bristle. For set contents, visit DickBlick.com.

NUMBER	DESCRIPTION	EACH	3/EA
A06046-1024	Synthetic Round/Flat	\$110.80	\$99.72
A06046-3072	Bristle Round/Flat	93.09	83.78
A06046-2072	Bristle Round	93.09	83.78
A06046-1072	Bristle Flat	93.09	83.78



#2 Round

#6 Flat

#8 Bright

Royal & Langnickel® Soft-Grip™ Golden Taklon Brushes

LONG handle

Designed with durability and comfort in mind, these economical brushes are as easy on your hands as they are on your wallet. They are made of durable, flake-free acrylic handles, with soft rubber rings along the length of the handle, and golden Taklon fibers that stand up to classroom use and work well with waterbased media.

Round

NUMBER	SIZE	DIA	LENGTH	EACH	12/EA
A06006-1002	2	1/8"	19/32"	\$3.22	\$2.89
A06006-1004	4	3/16"	27/32"	3.22	2.89
A06006-1006	6	1/4"	1-3/32"	3.22	2.89
A06006-1008	8	11/32"	1-1/4"	3.22	2.89

Flat

NUMBER	SIZE	WIDTH	LENGTH	EACH	12/EA
A06007-1002	2	5/16"	3/8"	\$3.22	\$2.89
A06007-1004	4	13/32"	17/32"	3.22	2.89
A06007-1006	6	15/32"	5/8"	3.22	2.89
A06007-1008	8	19/32"	3/4"	3.22	2.89
A06007-1010	10	23/32"	7/8"	3.22	2.89

Bright

NUMBER	SIZE	WIDTH	LENGTH	EACH	12/EA
A06008-1002	2	5/16"	9/16"	\$3.22	\$2.89
A06008-1004	4	13/32"	23/32"	3.22	2.89
A06008-1006	6	15/32"	13/16"	3.22	2.89
A06008-1008	8	19/32"	31/32"	3.22	2.89
A06008-1010	10	23/32"	1-5/32"	3.22	2.89



M-R Royal & Langnickel® Soft-Grip™ Brush Sets

SHORT handle

Designed with comfort in mind, these economical brushes are as kind to the hands as they are to the wallet. The durable Golden Taklon stands up to classroom abuse and works well with acrylics, watercolors, and tempera. The handles are thick acrylic with a soft rubber grip, making them easy to hold.

M Starter 5-Piece Set — Contains Oval Mop 3/4", Liner 20/0, Round 5, Filbert 8, and Shader 8.

NUMBER	EACH	6/EA
A05890-1019	\$17.75	\$15.95

N Beginner 5-Piece Set — Contains Glaze Wash 3/4", Liner 5/0, Round 4, Angular 3/4", and Shader 8.

NUMBER	EACH	6/EA
A05890-1029	\$17.75	\$15.95

O Round 5-Piece Set — Contains Sizes 0, 2, 4, 6, 10.

NUMBER	EACH	6/EA
A05890-1039	\$17.75	\$15.95

P Flat 5-Piece Set — Contains Sizes 4, 8, 10, 12, and 3/4" Glaze Wash.

NUMBER	EACH	6/EA
A05890-1049	\$17.75	\$15.95

Q White Taklon 5-Piece Set — Contains Bright sizes 1, 6, 8, Filbert 8, and Round 2.

NUMBER	EACH	6/EA
A05890-1059	\$17.75	\$15.95

R Texture 5 Piece Set — Contains White Mini Mop 3/4", Sableline Mini Mop 3/4", Bristle Fan 4, Taklon Comb 3/8", and Fitch Deerfoot 3/8".

NUMBER	EACH	6/EA
A05890-1069	\$17.75	\$15.95



Royal & Langnickel® Soft-Grip™ 72-Brush Class Packs

Packs contain 12 each of six assorted styles and sizes, including Flats, Rounds, Fans, and more, in a storage/drying tray. For set contents, visit DickBlick.com.

NUMBER	SIZE	EACH	3/EA
A05890-1729	Long Handle	\$291.29	\$262.15
A05890-1079	Short Handle	187.85	169.07
A05890-1089	Short Handle	187.85	169.07
A05890-0729	Short Handle	187.85	169.07
A05890-1099	Short Handle	187.85	169.07

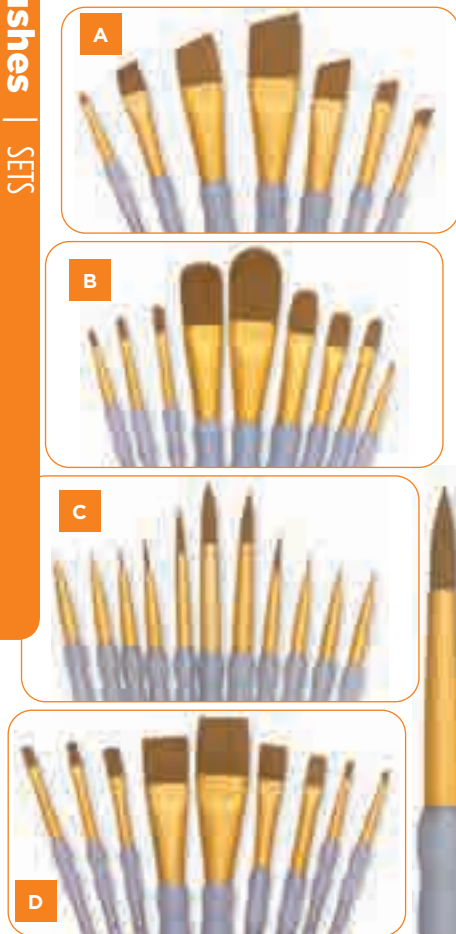

A-D Royal & Langnickel® Crafter's Choice™ Brush Sets SHORT handle

Royal Crafter's Choice brushes are fitted with a durable polymer handle and "no slip" soft rubber grip, providing hours of painting comfort. These Brown Taklon sets include a variety of shapes and sizes for use with acrylics, watercolors, and tempera.

A Angular 7-Piece — Includes 1/8", 1/4", 3/8", 1/2", 5/8", 3/4", and 1".

NUMBER	EACH	6/EA
A06980-1007	\$14.98	\$13.48

B Filbert/Oval Wash 9-Piece — Includes Size 0, 2, 4, 6, 8, 10, and 12 Filbert, plus 3/4" and 1" Oval.

NUMBER	EACH	6/EA
A06980-1199	\$14.98	\$13.48

C Round 11-Piece — Includes Size 20/0, 10/0, 5/0, 3/0, 0, 1, 3, 5, 6, 8, and 10.

NUMBER	EACH	6/EA
A06980-1109	\$14.98	\$13.48

D Shader/Wash 9-Piece — Includes 0, 2, 4, 6, 8, 10, and 12 Shader, plus 3/4" and 1" Wash.

NUMBER	EACH	6/EA
A06980-1099	\$14.98	\$13.48



Royal & Langnickel® Scholastic 72-Piece Classroom Assortments SHORT handle

Polymer handles, soft rubber grippers, and a choice of synthetic or natural hair make these brushes ideal for watercolors, acrylics, tempera, and glazing. Each set includes 72 brushes in a storage/drying tray.

Gold Taklon Combo — Includes 12 each of Sizes 3, 6, and 8 Round, Sizes 4 and 8 Shader, and 1/2" Wash.

NUMBER	EACH	6/EA
A06074-1072	\$121.25	\$109.15

Gold Taklon Round Combo — Includes 24 each of Sizes 3, 6, and 8 Round.

NUMBER	EACH	6/EA
A06074-2072	\$121.25	\$109.15

Gold Taklon Shader Combo — Includes 24 each of Sizes 4 and 8 Shader, and 1/2" Wash.

NUMBER	EACH	6/EA
A06074-3072	\$121.25	\$109.15

Gold Taklon Speciality Combo — Includes 12 each of Size 4 Fan, Sizes 3/0 and 1" Liner, Size 5/8" Wash, Size 4 Filbert, and Size 3/8" Angular.

NUMBER	EACH	6/EA
A06074-4072	\$121.25	\$109.15

Natural Hair Combo — Includes 12 each of Sizes 1/2" and 3/4" Mop, Sizes 1/4" and 1/2" Flat, and Sizes 2 and 6 Round.

NUMBER	EACH	6/EA
A06074-5072	\$121.25	\$109.15

White Taklon Combo — Includes 12 each of Sizes 2, 6 and 10 Shader, and Sizes 3, 5, and 8 Round.

NUMBER	EACH	6/EA
A06074-6072	\$121.25	\$109.15

< Royal & Langnickel® Aqua-Flo™ Brushes SHORT handle

Fill these reusable brush handles with water for use with watercolors, tempera cakes, or watercolor pencils. They can also be loaded with liquid watercolors, fluid inks, and even rubbing alcohol. Give a gentle squeeze on the handle, and the fluid flows out.

NUMBER	DESCRIPTION	EACH	6/EA
A06005-1039	3-Brush Set	\$5.03	\$4.52
A06046-1036	36-Brush Class Pack	68.75	61.88

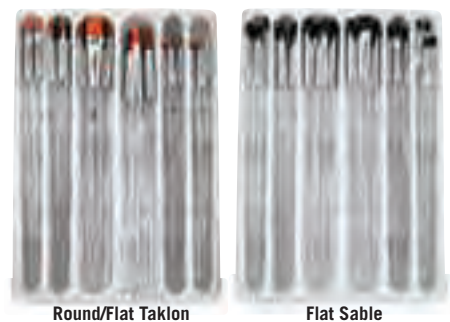

Round/Flat Taklon Flat Sable

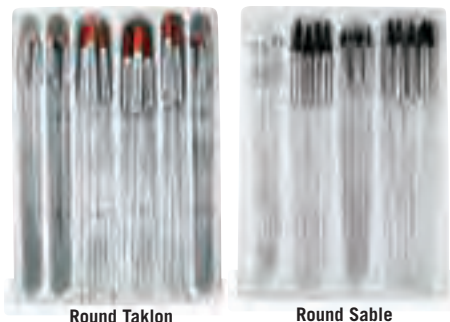

Round Taklon Round Sable

Royal & Langnickel® Clear Choice™ Value Sets SHORT handle

Clear Choice brushes feature short acrylic handles that won't chip or peel, and high-quality natural or synthetic brush fibers. Choose from a variety of affordable, 24-brush value packs. For set contents, visit DickBlick.com.

NUMBER	DESCRIPTION	EACH	12/EA
A06296-1019	Flat Taklon	\$30.50	\$27.45
A06296-1029	Round	30.50	27.45
A06296-1009	Round/Flat Taklon	30.50	27.45
A06296-1039	Flat Sable	30.50	27.45
A06296-1049	Round Sable	30.50	27.45
A06296-1069	Flat/Round Sable	30.50	27.45
A06296-1059	Ceramic Combo Sable/Goat	30.50	27.45



Royal & Langnickel® Clear Choice™ Class Pack SHORT handle

144-Brush Assortment! Golden Taklon hairs and durable, clear acrylic handles make these brushes a true workhorse. Perfect for the demands of classroom use, they work with most media. Class Pack contains 12 each of the following shapes and sizes: Shader Sizes 4, 8, and 12. Round Sizes 20/0, 3/0, 1, 3, 5, 8, 10. Flat Sizes 1/2" and 3/4".

NUMBER	EACH	3/EA
A05891-1449	\$323.00	\$290.99



E-N Royal & Langnickel® Value Sets SHORT handle

E Golden Taklon Rounds, Set of 30 — For all waterbased media. The set includes five each of Sizes 1, 3, 5, 8, 10, and 12 Rounds with short wood handles.

NUMBER	EACH	3/EA
A06060-1001	\$21.85	\$19.66

F Golden Taklon Flats, Set of 30 — For all waterbased media. The set includes five each of Sizes 2, 4, 6, 8, 10, and 12 Flats with short wood handles.

NUMBER	EACH	3/EA
A06060-1002	\$21.85	\$19.66

G Golden Taklon Rounds and Flats, Set of 30 — For tempera, watercolors, and acrylics. Includes five each of Sizes 3, 6, and 10 Round, and Sizes 4, 8, and 12 Flat, plus a bonus brush-drying and storage rack.

NUMBER	EACH	3/EA
A06060-1030	\$21.85	\$19.66

H Golden Taklon Large Area Brushes, Set of 12 — For tempera, watercolors, and acrylics. Includes four each of Sizes 1, 2, and 3 Large Area brushes, plus a bonus brush-drying and storage rack.

NUMBER	EACH	3/EA
A06060-1012	\$21.85	\$19.66

I Natural Rounds and Flats, Set of 30 — For watercolors and tempera. Includes five each of Sizes 3, 6, and 10 Round, and Sizes 4, 8, and 12 Flat, plus a bonus brush-drying and storage rack.

NUMBER	EACH	3/EA
A06060-2030	\$21.85	\$19.66

J Plastic Palette Knives, Set of 36 — For oils and acrylics. Includes six of each style, plus a bonus drying and storage rack.

NUMBER	EACH	3/EA
A06060-1036	\$21.85	\$19.66

K Camel Rounds, Set of 24 — For watercolors and tempera. Includes six each of Sizes 3, 5, 8, and 12 Round, plus a bonus brush-drying and storage rack.

NUMBER	EACH	3/EA
A06060-1024	\$21.85	\$19.66

L Chubby Brushes, Set of 24 — For tempera, watercolors, and acrylics. Includes 12 Round and 12 Flat brushes, plus a bonus brush-drying and storage rack.

NUMBER	EACH	3/EA
A06060-3024	\$21.85	\$19.66

M Bristle Large Area Brushes, Set of 12 — For oils and acrylics. Includes four each of Sizes 1, 2, and 3 Large Area brushes, plus a bonus brush-drying and storage rack.

NUMBER	EACH	3/EA
A06060-2012	\$21.85	\$19.66

N Ceramic Glaze Brushes, Set of 16 — For all glazes. Includes four each of Size 3 Round, Size 4 Fan, Size 6 Flat, and Size 3/4" Glaze, plus a bonus brush-drying and storage rack.

NUMBER	EACH	3/EA
A06060-1016	\$21.85	\$19.66



Taklon, Round/Flat/Shader Set of 120



Natural, Round/Flat Set of 120



Taklon Set of 30 Natural Set of 30

Royal & Langnickel® Classroom Assortments SHORT handle

These economical brush assortments feature acrylic handles that won't crack or peel when left in water — perfect for the classroom! Choose Golden Taklon or soft natural hair. The 30-brush assortments include three 10-brush sets in resealable pouches. For set contents, visit DickBlick.com.

NUMBER	DESCRIPTION	EACH	6/EA
A06278-1002	Taklon, Round/Flat	\$29.13	\$26.23
A06278-1001	Natural, Round/Flat	29.13	26.23

NUMBER	DESCRIPTION	EACH	3/EA
A06276-1009	Taklon, Round/Flat/Shader	\$98.65	\$88.79
A06276-1019	Taklon, Round/Flat	98.65	88.79
A06276-1029	Natural, Round/Flat	98.65	88.79



Royal & Langnickel® Majestic Classroom Assortment SHORT handle

Royal's best-quality taklon filaments make these brushes ideal for any waterbased media. Flake-proof acrylic handles. Every set includes a divided plastic storage tray for drying and storing brushes flat. Includes 12 each of Round sizes 3, 6, and 10; Flat sizes 6 and 10; and Wash Size 3/4".

NUMBER	EACH	3/EA
A06046-7072	\$185.67	\$164.40



Dynasty Faux Camel Watercolor Brushes SHORT handle

Ideal for teaching students about physical health and emotional health while learning to paint with watercolors, these brushes are vegan, cruelty-free, and comprised of biodegradable components. The unpainted wood handles are sourced from FSC-managed forests, making them healthy for children and the planet. These brushes allow for teachable moments regarding allergens, chemical exposure from dyes and lacquer, and emotional health (no animals were hurt, the Earth was not hurt).

Dynasty addresses these concerns with eco-friendly, cruelty-free synthetic camel hair. These unique watercolor brushes come in handy canisters for ease of distribution and storage in the classroom. For set contents, visit DickBlick.com.

NUMBER	DESCRIPTION	EACH	3/EA
A06282-1001	144 Rounds	\$312.00	\$280.80
A06282-1002	72 Flats	219.85	197.89
A06282-1003	108 Rounds and Flats	272.35	245.15

NUMBER	SIZE	WIDTH	LENGTH	EACH	12/EA
A06291-1014	1/4"	1/4"	1/2"	\$2.52	\$2.27
A06291-1038	3/8"	3/8"	5/8"	2.96	2.66
A06291-1012	1/2"	1/2"	3/4"	3.43	3.09
A06291-1034	3/4"	3/4"	1"	4.35	3.92
A06291-1001	1"	1"	1-29/64"	5.26	4.73

NUMBER	SIZE	WIDTH	LENGTH	EACH	12/EA
A06292-1001	1	1/8"	3/8"	\$1.87	\$1.68
A06292-1002	2	1/8"	3/8"	2.03	1.82
A06292-1004	4	1/8"	5/8"	2.41	2.17
A06292-1006	6	3/16"	3/4"	2.85	2.56
A06292-1008	8	3/16"	53/64"	3.35	3.03
A06292-1010	10	3/16"	1"	4.07	3.66
A06292-1012	12	1/4"	1-9/64"	5.11	4.59



Dynasty Eye of the Tiger Brushes SHORT handle

Handcrafted synthetic brushes with black acrylic handles and seamless gold-colored ferrules. Long-lasting performance at a value price.

NUMBER	DESCRIPTION	EACH	3/EA
A06033-1010	120 Shaders	\$154.99	\$139.50
A06033-1015	150 Rounds	152.05	136.84
A06033-1020	72 Filberts/Angulars	126.87	114.18
A06033-1025	96 Shaders/Rounds	133.41	120.07



A-F Dynasty Mastodon Synthetic Brush Canisters SHORT handle

Made from a superior synthetic for long-lasting performance with oils and acrylics. A seamless gold-tone ferrule and crystal-clear acrylic handle assure long-lasting performance and beauty. For canister details and additional canister sets for oils and acrylics, visit DickBlick.com.

NUMBER	DESCRIPTION	EACH
A06579-7100	A Shader, 120	\$215.69
A06579-7130	B Round, 120	226.65
A06579-7200	C Filbert/Angle, 84	186.25
A06579-7250	D Shader/Round, 96	194.35
A06579-7300	E Liner, 144	252.10
A06579-7350	F Fan/Glaze, 60	258.15



Dynasty Blue Ice Brush Canisters LONG handle

The Dynasty Blue Ice brush collection combines the strength of glacial ice with flexibility to move heavy-bodied media. Intended for multimedia work in oils and acrylics, every brush incorporates two synthetic fibers of different strengths and absorbencies that are designed to hold more media. Every stunning blue brush has a soft white tip. The brush hairs are attached to kiln-dried white birch handles with a matte black finish. Blue Ice Brushes release a smooth flow of paint on small or large surfaces.

NUMBER	DESCRIPTION	SHAPE	EACH	6/EA
A04425-1150	Set of 50	Brights	\$222.89	\$200.60
A04425-1250	Set of 50	Flats	222.89	200.60
A04425-1350	Set of 50	Rounds	259.25	233.35
A04425-1460	Set of 60	Easels	268.35	241.50
A04425-1060	Set of 60	Brights and Rounds	245.61	221.05



G-K Dynasty Synthetic White Bristle and Faux Sable Canisters LONG handle

Superior synthetic for long-lasting performance. Choose Synthetic White Bristle with Cherry-finish natural wood handles (60 per canister), or faux sable with natural wood handles (72 per canister). All feature long handles and seamless silvertone ferrules. For details, visit DickBlick.com.

NUMBER	DESCRIPTION	EACH
A06068-1009	G 60 Synthetic White Bristle Flats	\$122.59
A06068-2009	H 60 Synthetic White Bristle Rounds	122.59
A06068-3009	I 60 Synthetic White Bristle Brights	122.59
A06069-1009	J 72 Faux Sable Flats	117.19
A06069-2009	K 72 Faux Sable Rounds	117.19



Dynasty Red Sable Style Canisters LONG handle

72-Brush Assortment! These artist-quality brushes have hair that mimics red sable when working with oil and acrylic paints. The long black lacquered handles offer superb balance and control, and feature a white tip and seamless nickel ferrule.

Round — Includes 72 brushes, 12 each of Size 0, 2, 4, 6, 8, and 10 Rounds.

NUMBER	DESCRIPTION	EACH	3/EA
A06001-0729		\$203.40	\$183.05

NUMBER	DESCRIPTION	EACH	3/EA
A06002-0729		\$222.99	\$200.75



L-N Dynasty Bright Gold Nylon Acrylic Brush Canisters LONG handle

Made from a superior, bright gold nylon acrylic for long-lasting performance, these brushes feature seamless anodized aluminum ferrules and natural long wood handles. Designed for use with oil and acrylic paints.

L Bright, Canister Set of 50 — This set contains 50 brushes (10 each of Bright, sizes 2, 4, 6, 8, and 10).

NUMBER	EACH	3/EA
A06071-2009	\$209.70	\$188.75

M Flat, Canister Set of 50 — This set contains 50 brushes (10 each of Flat, sizes 2, 4, 6, 8, and 10).

NUMBER	EACH	3/EA
A06071-3009	\$209.70	\$188.75

N Round, Canister Set of 50 — This set contains 50 brushes (10 each of Round, sizes 2, 4, 6, 8, and 10).

NUMBER	EACH	3/EA
A06071-1009	\$209.70	\$188.75



R-S Dynasty Golden Synthetic Wash Glaze Brush Canisters LONG handle

Wash Glaze 40-Brush Assortment — Fine, gold synthetic hair is suitable for all types of media, and the flat shape provides superb coverage. These are great brushes for the classroom because they clean easily and stand up to repeated use. Black lacquered handle offers a sure grip and control. Seamless nickel ferrule. Includes 10 each of Flat 1/4", 1/2", 3/4", and 1".



O-Q Dynasty Golden Synthetic Script and Liner Brush Canisters LONG handle

Script and Liner 144-Brush Assortment — Contains 24 each of Script and Mini Liner sizes 15/0, 5/0, and 1.

NUMBER	EACH	3/EA
A06078-1449	\$240.45	\$216.40

P Angle and Filbert 72-Brush Assortment — Golden synthetic hair is perfectly balanced for almost any paint media, and the generous points are perfect for medium coverage. Black lacquered, medium-length handle and seamless nickel ferrule. Includes 12 each of Angle for detail: 1/4", 3/8", 1/2" and 12 each of Filbert: 4, 6, 8 for larger areas of coverage.

NUMBER	EACH	3/EA
A05199-0729	\$250.05	\$225.15

Q Wash Glaze 40-Brush Assortment — Fine, gold synthetic hair is suitable for all types of media, and the flat shape provides superb coverage. These are great brushes for the classroom because they clean easily and stand up to repeated use. Black lacquered handle offers a sure grip and control. Seamless nickel ferrule. Includes 10 each of Flat 1/4", 1/2", 3/4", and 1".

NUMBER	EACH	3/EA
A06000-0409	\$168.55	\$151.70

Flat Wash Refill Brushes

NUMBER	SIZE	EACH	12/EA
A06000-5014	1/4"	\$2.95	\$2.65
A06000-5012	1/2"	4.65	4.19
A06000-5034	3/4"	5.75	5.18
A06000-1001	1"	6.75	6.07

R-S Dynasty Golden Taklon SHORT handle

For all media, including watercolor and decorative work. Premium Golden Taklon is hand-shaped for superior performance at a value price. High-gloss nickel ferrule; short, black lacquered handles.

R Flat Shader Canister — Contains 18 each of Flat Shader sizes 2, 4, 6, 8, 10, and 12, 108 brushes in all!

NUMBER	EACH	3/EA
A05185-0108	\$201.55	\$181.50

S Round Canister — Contains 24 each of Round sizes 5/0, 3/0, 2/0, 2, 4, and 6, 144 brushes in all!

NUMBER	EACH	3/EA
A05185-0144	\$201.55	\$181.50

Round Refill Brushes

NUMBER	SIZE	EACH	12/EA
A05185-7050	5/0	\$2.23	\$2.03
A05185-7030	3/0	2.23	2.03
A05185-7020	2/0	2.59	2.37
A05185-1000	0	2.59	2.37
A05185-1002	2	2.97	2.72
A05185-1004	4	3.21	2.95
A05185-1006	6	3.76	3.45
A05185-1008	8	4.31	3.94
A05185-1010	10	5.35	4.90
A05185-1012	12	6.69	6.10



T-U Dynasty Fine Gold Nylon Brush Set LONG handle

This set of acrylic/oil brushes features natural wood handles. It contains 60 brushes, 12 each of five sizes, including Size 2 Flat, Size 4 Flat, Size 6 Flat, Size 8 Flat, and Size 6 Round.

NUMBER	EACH	3/EA
A05128-1060	\$166.15	\$137.99

U Dynasty Golden Nylon 144-Brush Assortment!

Excellent-quality synthetic bristle brushes. Assortment includes 24 each of size 1, 3, and 5 Rounds, and 24 each of size 4, 6, and 8 Flat Shaders. Seamless goldtone ferrules on clear lacquered, short wood handles.

NUMBER	EACH	3/EA
A05121-9144	\$176.39	\$158.75

Flat Shader Refill Brushes

NUMBER	SIZE	EACH	12/EA
A05121-1001	1	\$1.99	\$1.79
A05121-1003	3	2.08	1.87
A05121-1005	5	2.19	1.97



Kid Dynasty® Canisters
30-Brush Assortment!

SHORT handle

Exceptional quality at a fraction of the price! These brushes are perfectly suited for small hands and big imaginations. Flat black easel style or natural white bristle. With 30 brushes to choose from in assorted sizes, you can bring out the artist in every student.

NUMBER	COLOR	EACH	3/EA
A05135-1019	Black	\$59.99	\$53.99
A05135-1009	White	54.65	49.19



Dynasty® White Bristle

SHORT handle

72-Brush Assortment!

Great for use with tempera, oil, or acrylic paints, these natural Chinese white bristle brushes are economical as well as durable. Seamless ferrules are securely attached to short, natural wooden handles. Fine White Bristle: 12 each of Flat sizes 2, 4, 6 and Round sizes 1, 3, 5.

NUMBER	EACH	3/EA
A05187-2009	\$62.09	\$51.80

Dynasty® Economy Camel Hair

SHORT handle

144-Brush Assortment!

One gross of assorted, all-purpose camel hair brushes per package. Short natural wooden handles, six different sizes — two dozen brushes of each size.

NUMBER	EACH	3/EA
A05118-9144	\$51.93	\$46.73

Dynasty® Fine Camel Hair

SHORT handle

120-Brush Assortment!

120 Round watercolor brushes in five assorted sizes: 2, 4, 6, 8, and 10. Short natural wood handles with a durable enamel coating.

NUMBER	EACH	3/EA
A05129-9120	\$98.55	\$88.70



A-B Dynasty® White Bristle
36-Brush Assortment!

LONG handle

These handmade oil painting brushes are made of the finest white Chinese hog bristle, interlocked to create a durable, flagged tip. Every brush has a seamless, polished ferrule, and a long handle with at least four coats of lacquer. Choose canisters of Rounds or Flats. Each contains 12 each of Sizes 8, 10, and 12.

NUMBER	DESCRIPTION	EACH	3/EA
A05190-0369	A Rounds	\$184.85	\$166.45
A05190-1369	B Flats	184.85	166.45

C-F Dynasty® White Bristle

LONG handle

60-Brush Assortment!

60-piece canister assortments offer high quality, versatility, and selection with volume purchasing economy. Natural white bristles are ideal for a wide variety of art, craft, fabric, and ceramic projects. Assortments contain 12 each of sizes 2, 4, 6, 8, and 10 brushes in various shapes.

NUMBER	DESCRIPTION	EACH	3/EA
A06079-1060	C Brights	\$137.85	\$124.05
A06079-2060	D Rounds	137.85	124.05
A06079-3060	E Flats	137.85	124.05
A06079-4060	F Filberts	182.99	164.69

G Dynasty® White Bristle Assortment

LONG handle

72-Brush Assortment!

Interlocked white bristle on long, natural wood handles. The 72-piece assortment includes 12 each of 2, 4, and 6 Rounds, and 2, 4, and 6 Flats.

NUMBER	EACH	3/EA
A05131-0072	\$166.99	\$138.69

H Dynasty® Red Sable Style & White Bristle Assortment

LONG handle

This sable style brush hair mimics red sable when working with oil and acrylic paints. The hairs are hand selected and shaped to give the Rounds a nice point and the Flats a square knife edge. The white Chinese Hog Bristle brushes deliver paint to larger areas, with interlocked bristles that help maintain the brush shape. This 60-piece canister includes 12 each of Red Sable Style Flats (Size 6) and Rounds (Size 4); plus White Bristle Rounds (Size 4) and Flats (Sizes 4 and 8).

NUMBER	EACH	3/EA
A05978-0609	\$161.45	\$134.09



Helpful for individuals with special needs.



Dynasty® Ruby Student Synthetic

72-Brush Assortment!

SHORT handle

The brilliant red synthetic hair is durable and perfectly balanced for watercolor work. It's set on a transparent acrylic handle with seamless goldtone ferrule and offered in a variety of brush styles and sizes. A great value for the classroom. Includes 12 each of Round detail brush 10/0 and 4; Flat brush 6 and 14 for bold, sweeping lines; Angle 1/4" for varied lines and color-carrying capability and Oval 2 for a soft edge with no point.

NUMBER	EACH	3/EA
A05198-0729	\$108.69	\$97.85

Dynasty® Sapphire Student

72-Brush Assortment!

SHORT handle

Synthetic fiber is durable for watercolor painting and the sharp point has good spring and versatility. Short, transparent acrylic handle stands up to daily kid use and offers superb control. Seamless goldtone ferrule.

Round — Includes 12 each of Round sizes 10/0, 2, 4, 6, 8, and 10.

NUMBER	EACH	3/EA
A05197-0729	\$108.69	\$97.85

Flat — Includes 12 each of Flat sizes 2, 4, 6, 8, 10, and 14.

NUMBER	EACH	3/EA
A06003-0729	\$108.69	\$97.85



Princeton™ Gold Nylon Rounds

72-Brush Assortment!

SHORT handle

Contains 72 assorted round Golden Nylon brushes for watercolor, acrylic, or tempera. An economical way to buy great quality.

NUMBER	EACH	3/EA
A05134-1072	\$102.65	\$92.39



I-M Dynasty® White Taklon
Canister Assortments

SHORT handle

White Taklon with seamless nickel-plated ferrules on short, red lacquered handles.

I 40-Brush Assortment (Flat, Wash, and Glaze) —

Contains 10 each of 1/4", 1/2", 3/4", and 1" Flat, Wash, and Glaze brushes.

NUMBER	EACH	6/EA
A09093-3060	\$156.85	\$141.17

J 72-Brush Assortment, Angles and Filberts — Contains

12 each of 1/4", 3/8", and 1/2" Angles and 12 each of Sizes 4, 6, and 8 Filberts.

NUMBER	EACH	6/EA
A09093-4060	\$185.75	\$167.18



Liquitex® Basics Brush
Ultimate Class Pack

LONG handle

Liquitex Basics Brushes Ultimate Class Pack offers all the brush sizes and shapes a classroom needs. The four shapes (Round, Bright, Filbert, and Flat) can be used for initial designs, adding finishing details, and every stage in between. Includes 96 long-handle brushes, 12 each of size 2, 3, and 6 Rounds; size 3 and 8 Brights; size 2 and 4 Filberts; and size 2 Flats.

NUMBER	EACH	3/EA
A04454-1096	\$142.17	\$127.95

See Page 132 for more Liquitex Basic Brushes

K 108-Brush Assortment, Flat Shaders — Contains 18

each of Sizes 2, 4, 6, 8, 10, and 12 Flat Shaders.

NUMBER	EACH	6/EA
A09093-1060	\$190.75	\$171.68

L 120-Brush Assortment — Contains 24 Round

brushes in Sizes 0, 2, 4, 6, and 8.

NUMBER	EACH	3/EA
A05130-9120	\$261.39	\$235.25

M 144-Brush Assortment, Rounds — Contains 24 each

of Sizes 5/0, 3/0, 2/0, 2, 4, and 6 Rounds.

NUMBER	EACH	6/EA
A09093-2060	\$190.75	\$171.68

Round Refill Brushes

NUMBER	SIZE	EACH	12/EA
A05130-1000	0	\$2.63	\$2.37
A05130-1002	2	2.63	2.37
A05130-1004	4	3.05	2.75
A05130-1006	6	3.58	3.23
A05130-1008	8	4.19	3.77



Liquitex® Basics Plastic Mixing Knives

Contains 72 flexible white plastic knives specially designed for mixing and applying acrylic colors. Highly maneuverable thanks to their convenient and comfortable trowel shape, Liquitex Basics Plastic Mixing Knives measure 7" in total length with a 2-7/8" offset blade. The offset blade is what allows these knives to be ideal for mixing or applying colors directly to the painting surface.

NUMBER	EACH	4/EA
A02819-1001	\$119.79	\$107.79



Richeson Slightly Imperfect Assorted Brush Set

42-Brush Assortment!
An incredible value, this slightly imperfect brush assortment is perfect for schools. The set includes a variety of different brush sizes, hairs, and styles with minor cosmetic imperfections, which will not affect performance. Each set includes a different assortment.

NUMBER	EACH	10/EA
A06032-1009	\$30.64	\$27.56



Da Vinci Junior Synthetic SHORT handle

Don't be fooled by the name. These brushes were developed with the beginning artist in mind, but they are crafted for the professional. High-quality golden nylon hairs are placed in a rustproof metal ferrule and attached to a specially designed "non-roll," short wooden handle. Da Vinci Junior brushes can be used with virtually any type of paint.

Round						
NUMBER	SIZE	DIA	LENGTH	EACH	12/EA	
A05136-1001	1	1/16"	13/32"	\$3.58	\$3.22	
A05136-1002	2	3/32"	13/32"	3.58	3.22	
A05136-1004	4	1/8"	9/16"	4.36	3.92	
A05136-1006	6	5/32"	3/4"	5.24	4.71	
A05136-1008	8	3/16"	7/8"	6.56	5.90	
A05136-1010	10	3/16"	15/16"	9.37	8.43	
A05136-1012	12	7/32"	1"	12.40	11.16	
A05136-1014	14	1/4"	1"	15.38	13.83	
A05136-1016	16	9/32"	1-1/4"	17.58	15.82	
A05136-1018	18	3/8"	1-13/32"	24.20	21.77	
A05136-1020	20	13/32"	1-17/32"	27.51	24.74	

Bright						
NUMBER	SIZE	WIDTH	LENGTH	EACH	12/EA	
A05146-1002	2	1/8"	11/32"	\$4.36	\$3.92	
A05146-1004	4	5/32"	3/8"	5.24	4.71	
A05146-1006	6	7/32"	15/32"	5.79	5.21	
A05146-1008	8	5/16"	17/32"	6.56	5.90	
A05146-1010	10	3/4"	5/8"	7.44	6.69	
A05146-1012	12	7/16"	21/32"	9.37	8.43	
A05146-1014	14	1/2"	11/16"	10.97	9.87	
A05146-1016	16	9/16"	3/4"	13.78	12.40	
A05146-1020	20	11/16"	25/32"	17.36	15.62	
A05146-1024	24	3/4"	15/16"	25.30	22.76	

Richeson 48-Piece Utility Brush Assortment

Natural white bristle brushes in assorted sizes are great for painting murals or covering large canvases. Set includes 1" brushes (24), 2" brushes (12), and 3" brushes (12), all with wood handles.

NUMBER	EACH	3/EA
A06273-0489	\$72.79	\$65.50



Richeson 24-Piece White Bristle Brush Assortment

Includes Flats in Sizes 1–12 and Rounds in Sizes 1–12 for a total of 24 brushes.

NUMBER	EACH	3/EA
A06077-0249	\$26.07	\$23.48



Da Vinci Junior Synthetic 6-Brush Set

Includes Size 1, 4, and 8 Rounds, and Size 4, 6, and 10 Brights.

NUMBER	EACH	6/EA
A06272-1009	\$31.36	\$28.23



Da Vinci College Synthetic LONG handle

Designed for students ready to advance to the next level in painting, College brushes are a durable option that offer years of great performance at a nice price. These long-handled brushes feature strong, supple, elastic synthetic fibers that are easy to clean, plus rustproof ferrules. For oils and acrylics.

Round						
NUMBER	SIZE	DIA	LENGTH	EACH	12/EA	
A09210-1000	0	1/16"	3/8"	\$3.47	\$3.12	
A09210-1001	1	1/16"	25/64"	3.47	3.12	
A09210-1002	2	1/16"	7/16"	3.47	3.12	
A09210-1004	4	1/8"	5/8"	4.08	3.67	
A09210-1006	6	5/32"	5/8"	4.69	4.22	
A09210-1008	8	3/16"	53/64"	6.18	5.56	
A09210-1010	10	3/16"	1"	7.44	6.70	
A09210-1012	12	7/32"	1"	7.66	6.89	

Bright						
NUMBER	SIZE	WIDTH	LENGTH	EACH	12/EA	
A09209-1002	2	1/8"	11/32"	\$3.58	\$3.22	
A09209-1004	4	5/32"	3/8"	4.13	3.72	
A09209-1006	6	1/4"	15/32"	5.23	4.71	
A09209-1008	8	5/16"	33/64"	6.33	5.70	
A09209-1010	10	7/16"	5/8"	7.16	6.44	
A09209-1012	12	15/32"	43/64"	8.26	7.43	
A09209-1016	16	5/8"	3/4"	12.06	10.85	
A09209-1020	43/64"			13.77	12.38	

Filbert						
NUMBER	SIZE	WIDTH	LENGTH	EACH	12/EA	
A09150-1004	4	9/64"	5/16"	\$6.56	\$5.90	
A09150-1006	6	15/64"	5/16"	7.66	6.89	
A09150-1008	8	19/64"	35/64"	9.37	8.43	
A09150-1010	10	3/8"	19/32"	10.97	9.87	
A09150-1012	12	7/16"	5/8"	13.78	12.40	
A09150-1016	16	35/64"	25/32"	17.58	15.82	
A09150-1020	20	5/8"	15/16"	28.66	25.79	



Set of 10 — Includes Size 0, 2, and 6 Rounds, and Size 2, 4, 6, 8, 10, 12, and 16 Flats.

NUMBER	EACH	6/EA
A06272-2009	\$48.93	\$44.03

CRAYOLA®



#8 Series 1127 Camel Hair

#8 Series 1121 Camel Hair



#7 Series 1000 Taklon



1/2" Series 978 Nylon



3/4" Series 178 Black Bristle



Jumbo

Brushes shown actual size, except brush sets.

Crayola Series 1127 — Camel Hair Watercolor with Plastic Handles SHORT handle

This natural hair's round shape holds more fluid to cover large areas. Short yellow plastic handle. Ideal for watercolor paint sets.

NUMBER	SIZE	DIA	LENGTH	EACH	12/EA	36/EA
A05140-1001	1	1/16"	3/8"	\$0.97	\$0.87	\$0.83
A05140-1002	2	5/64"	7/16"	1.11	.99	.95
A05140-1003	3	3/32"	1/2"	1.21	1.09	1.04
A05140-1004	4	7/64"	9/16"	1.29	1.16	1.10
A05140-1005	5	9/64"	5/8"	1.38	1.24	1.18
A05140-1006	6	11/64"	11/16"	1.46	1.31	1.25
A05140-1007	7	3/16"	3/4"	1.53	1.38	1.31
A05140-1008	8	13/64"	13/16"	1.60	1.44	1.37
A05140-1010	10	1/4"	15/16"	1.80	1.62	1.54
A05140-1012	12	9/32"	1-1/16"	1.99	1.80	1.71

Crayola Series 1121 — Camel Hair Watercolor with Wood Handles SHORT handle

Natural hair brush with a durable short black wooden handle. For watercolor use in covering large areas.

NUMBER	SIZE	DIA	LENGTH	EACH	12/EA	24/EA
A05142-1001	1	1/16"	3/8"	\$1.45	\$1.30	\$1.24
A05142-1002	2	5/64"	7/16"	1.58	1.42	1.34
A05142-1003	3	3/32"	1/2"	1.70	1.52	1.45
A05142-1004	4	7/64"	9/16"	1.92	1.72	1.64
A05142-1005	5	9/64"	5/8"	2.04	1.83	1.74
A05142-1006	6	11/64"	11/16"	2.22	1.99	1.89
A05142-1007	7	3/16"	3/4"	2.36	2.12	1.99
A05142-1008	8	13/64"	13/16"	2.59	2.32	2.21
A05142-1010	10	1/4"	15/16"	2.93	2.63	2.50
A05142-1012	12	9/32"	1-1/16"	3.31	2.97	2.82

Crayola Large Paintbrush Variety Classpack

This economical pack of large-size paintbrushes is great for young artists. Kids can choose from a variety of brush shapes and sizes to make paintings, posters, murals, and more. Easy-grip plastic handles help them make broad strokes with confidence! The classpack includes 36 brushes, 12 each of Crayola Jumbo, Large Flat, and Large Round brushes.

NUMBER	EACH	6/EA
A06277-1036	\$65.17	\$58.65



Crayola Brush Sets SHORT handle

Versatile assortments of natural hair and synthetic brushes are ideal for watercolor, tempera, or acrylic techniques. Set of five synthetic brushes contains one each of five sizes. Eight-brush natural hair set contains an assortment of four sizes. Set of four round or flat synthetic brushes contains one each of four different sizes. Suitable for children ages 4 and up.

NUMBER	SET	EACH	12/EA	24/EA
A05144-1059	A 5 Shapes	\$3.89	\$3.50	\$3.33
A05144-1089	B 8 Sizes	3.89	3.50	3.33
A05144-1149	C Round Set of 4	5.54	4.98	4.74
A05144-1249	D Flat Set of 4	5.54	4.98	4.74

BLICK® economy

brushes for the beginning student

- good quality
- seamless aluminum ferrules
- lacquered natural wood handles
- value priced



A-B Blick® Economy Camel

The superior paint-holding ability of natural hair at an unbeatable price. A popular choice for watercolor and tempera painting. The short handles are sized just right for watercolor painting.

A Round							
NUMBER	SIZE	DIA	LENGTH	EACH	24/EA	48/EA	
A05153-1000	0	1/32"	9/32"	\$0.80	\$7.72	\$6.68	
A05153-1001	1	1/16"	7/16"	.84	.76	.72	
A05153-1002	2	1/16"	3/8"	.95	.85	.81	
A05153-1004	4	3/32"	9/16"	1.05	.95	.90	
A05153-1006	6	1/8"	21/32"	1.22	1.10	1.04	
A05153-1008	8	5/32"	13/16"	1.48	1.33	1.26	
A05153-1010	10	7/32"	1-1/32"	1.69	1.52	1.44	
A05153-1012	12	9/32"	1-1/4"	1.99	1.81	1.72	
A05153-1014	14	5/16"	1-11/32"	2.33	2.10	1.99	

B Oval Wash							
NUMBER	SIZE	DIA	LENGTH	EACH	24/EA	48/EA	
A05152-4012	1/2"	1/2"	1-1/16"	\$5.84	\$5.26	\$4.99	
A05152-4034	3/4"	3/4"	1-13/32"	6.18	5.56	5.28	
A05152-1001	1"	1"	1-1/2"	7.64	6.88	6.53	

Brushes shown actual size, except brush sets.

C Blick® Economy Sable — Round

One of the most popular choices for watercolor brushes due to its strength, spring, and ability to retain its shape. Sable hair is set on shorter, watercolor-size handles.

NUMBER	SIZE	DIA	LENGTH	EACH	24/EA	48/EA
A05147-1000	0	1/32"	11/32"	\$1.26	\$1.12	\$1.07
A05147-1001	1	1/16"	13/32"	1.44	1.29	1.23
A05147-1002	2	1/16"	7/16"	1.62	1.45	1.38
A05147-1004	4	3/32"	21/32"	1.71	1.53	1.46
A05147-1006	6	1/8"	13/16"	2.25	2.03	1.92
A05147-1008	8	5/32"	15/16"	2.80	2.50	2.39
A05147-1010	10	7/32"	1-1/16"	3.70	3.31	3.16
A05147-1012	12	9/32"	1-9/32"	5.24	4.69	4.47

D Blick® Economy Pony — Round

An economical choice for watercolor and tempera painting, excellent for students and hobbyists.

NUMBER	SIZE	DIA	LENGTH	EACH	24/EA	48/EA
A05105-2000	0	1/32"	9/32"	\$1.57	\$1.42	\$1.34
A05105-2001	1	1/16"	3/8"	1.68	1.51	1.43
A05105-2002	2	1/16"	1/2"	1.78	1.60	1.52
A05105-2004	4	3/32"	5/8"	1.89	1.70	1.61
A05105-2006	6	1/8"	3/4"	1.99	1.80	1.70
A05105-2008	8	5/32"	7/8"	2.10	1.89	1.79
A05105-2010	10	7/32"	1-1/16"	2.42	2.17	2.06
A05105-2012	12	9/32"	1-1/8"	2.74	2.46	2.33
A05105-2014	14	5/16"	1-1/4"	3.90	3.50	3.32



Blick® Economy Camel Round 9-Brush Set

Sizes: 0, 1, 2, 4, 6, 8, 10, 12, and 14.

NUMBER	EACH	12/EA	24/EA
A05153-0099	\$9.93	\$8.94	\$8.49

Blick® Economy Sable Round 4-Brush Set

Sizes: 1, 2, 4, and 6.

NUMBER	EACH	12/EA	24/EA
A05147-0049	\$5.66	\$5.09	\$4.84



Blick® Economy Pointed Sable Round 3-Brush Set

Sizes: 0, 1, and 4.

NUMBER	EACH	12/EA	24/EA
A05147-0039	\$4.15	\$3.72	\$3.53



Blick® Economy Sable Round Class Pack

Class pack of 36! Includes six each of Sizes 0, 1, 2, 4, 6, and 8.

NUMBER	EACH	3/EA	6/EA
A05147-0369	\$53.43	\$48.08	\$45.68

BLICK® scholastic

brushes for the intermediate student

- better quality
- seamless nickel-plated ferrules
- lacquered natural wood handles



Blick® Scholastic Pony Round 12-Brush Set

Sizes: 3/0, 2/0, 0, 1, 2, 4, 6, 8, 10, 12, 14, and 16.

NUMBER	EACH	6/EA	12/EA
A05865-0129	\$24.67	\$22.21	\$21.09



Blick® Scholastic Pony Bright 10-Brush Set

Sizes: 0, 1, 2, 4, 6, 8, 10, 12, 14, and 16.

NUMBER	EACH	6/EA	12/EA
A05864-0109	\$21.03	\$18.92	\$17.97



Blick® Scholastic Ox Round 12-Brush Set

Sizes: 3/0, 2/0, 0, 1, 2, 4, 6, 8, 10, 12, 14, and 16.

NUMBER	EACH	6/EA	12/EA
A05866-0129	\$37.40	\$33.67	\$31.98

E-F Blick® Scholastic Pony

Our Pony brushes (formerly Fitch) have smooth, textured hair, ideal for applying lots of color on flat or textured watercolor surfaces. Use them for filling in large areas of color.

E Round

NUMBER	SIZE	DIA	LENGTH	EACH	24/EA	48/EA
A05865-7030	3/0	1/64"	1/4"	\$1.48	\$1.33	\$1.27
A05865-7020	2/0	1/32"	5/16"	1.55	1.40	1.33
A05865-1000	0	1/32"	5/16"	1.63	1.46	1.40
A05865-1001	1	1/16"	11/32"	1.63	1.46	1.40
A05865-1002	2	1/16"	7/16"	1.70	1.53	1.46
A05865-1004	4	3/32"	15/32"	1.85	1.66	1.59
A05865-1006	6	1/8"	9/16"	2.08	1.86	1.78
A05865-1008	8	5/32"	5/8"	2.45	2.20	2.10
A05865-1010	10	7/32"	23/32"	2.82	2.53	2.42
A05865-1012	12	9/32"	13/16"	3.19	2.87	2.74
A05865-1014	14	5/16"	29/32"	3.56	3.20	3.06
A05865-1016	16	3/8"	15/16"	3.93	3.54	3.38

F Bright

NUMBER	SIZE	WIDTH	LENGTH	EACH	24/EA	48/EA
A05864-1000	0	1/32"	3/16"	\$1.71	\$1.64	\$1.56
A05864-1001	1	1/8"	7/32"	1.80	1.72	1.63
A05864-1002	2	3/32"	11/32"	1.97	1.88	1.79
A05864-1004	4	5/32"	3/8"	2.14	2.05	1.95
A05864-1006	6	3/16"	15/32"	2.23	2.13	1.99
A05864-1008	8	1/4"	17/32"	2.40	2.30	2.18
A05864-1010	10	5/16"	19/32"	2.57	2.46	2.34
A05864-1012	12	3/8"	11/16"	2.99	2.87	2.73
A05864-1014	14	15/32"	3/4"	3.69	3.53	3.35
A05864-1016	16	9/16"	27/32"	4.55	4.35	4.14

G Blick® Scholastic Ox Round

An excellent all-around workhorse for students painting with thicker, heavier colors. Dependable craftsmanship gives this brush nice balance; the hairs offer good resiliency and snap.

NUMBER	SIZE	DIA	LENGTH	EACH	24/EA	48/EA
A05866-7030	3/0	1/64"	1/4"	\$1.95	\$1.75	\$1.66
A05866-7020	2/0	1/32"	17/64"	1.95	1.75	1.66
A05866-1000	0	1/32"	9/32"	2.12	1.90	1.80
A05866-1001	1	1/16"	3/8"	2.38	2.13	1.99
A05866-1002	2	1/16"	15/32"	2.55	2.28	2.17
A05866-1004	4	3/32"	11/16"	2.80	2.51	2.38
A05866-1006	6	1/8"	3/4"	3.23	2.90	2.75
A05866-1008	8	5/32"	15/16"	3.82	3.43	3.26
A05866-1010	10	7/32"	1"	4.68	4.20	3.98
A05866-1012	12	9/32"	1-3/16"	5.95	5.34	5.07
A05866-1014	14	5/16"	1-3/8"	7.48	6.72	6.37
A05866-1016	16	3/8"	1-1/2"	9.19	8.25	7.82

H-I Blick® Scholastic Camel

Soft and strong, these 100% camel hair brushes are the workhorses of our Scholastic collection. Inexpensive, yet effective for watercolor and touch-up work. The Oval Wash produces a soft edge with no point, and is ideal for laying down large areas of color, wetting, or absorbing.

H Round

NUMBER	SIZE	DIA	LENGTH	EACH	24/EA	48/EA
A05867-7030	3/0	1/64"	5/16"	\$1.99	\$1.81	\$1.72
A05867-7020	2/0	1/32"	19/64"	1.99	1.81	1.72
A05867-1000	0	1/32"	11/32"	2.21	1.99	1.89
A05867-1001	1	1/16"	13/32"	2.31	2.08	1.98
A05867-1002	2	1/16"	7/16"	2.51	2.26	2.15
A05867-1004	4	3/32"	21/32"	2.81	2.53	2.41
A05867-1006	6	1/8"	11/16"	3.32	2.99	2.84
A05867-1008	8	5/32"	13/16"	3.82	3.44	3.27
A05867-1010	10	7/32"	1-1/16"	4.53	4.08	3.88
A05867-1012	12	9/32"	1-5/16"	5.53	4.98	4.74
A05867-1014	14	5/16"	1-7/16"	6.34	5.71	5.43

I Oval Wash

NUMBER	SIZE	WIDTH	LENGTH	EACH	24/EA	48/EA
A05868-4012	1/2"	1/2"	1"	\$4.70	\$4.25	\$4.05
A05868-4034	3/4"	3/4"	1-5/16"	6.40	5.75	5.45
A05868-1001	1"	1"	1-9/16"	10.09	9.09	8.63



Blick® Scholastic Camel Round 9-Brush Set

Sizes: 0, 1, 2, 4, 6, 8, 10, 12, and 14.

NUMBER	EACH	12/EA	24/EA
A05867-0099	\$26.42	\$23.77	\$22.58

BLICK® scholastic

brushes for the intermediate student

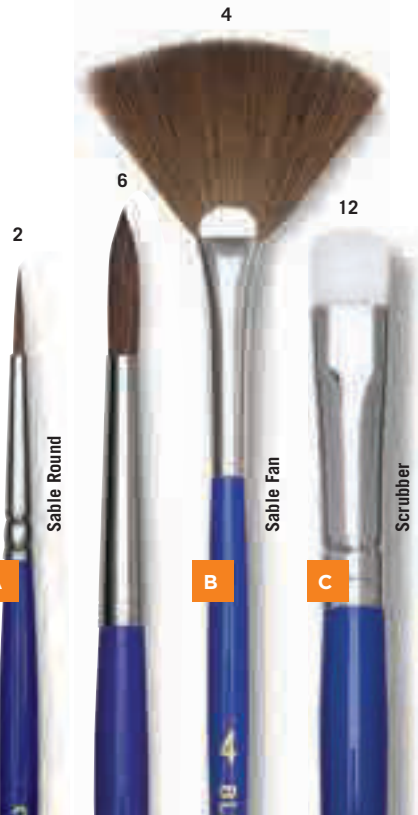

Blick® Scholastic Red Sable Round 4-Brush Set SHORT handle
 Sizes: 0, 1, 2, and 4.
 NUMBER EACH 12/EA 24/EA
 A05863-0049 \$7.63 \$6.87 \$6.52

Blick® Scholastic Red Sable Spotter 3-Brush Set SHORT handle
 Sizes: 3/0, 2/0, and 0 Round.
 NUMBER EACH 12/EA 24/EA
 A05873-0039 \$4.85 \$4.36 \$4.13

A-B Blick® Scholastic Red Sable SHORT handle
 Excellent craftsmanship at a price that brings a professional-quality brush within student reach. These brushes offer snap and resiliency.

A Round

NUMBER	SIZE	DIA	LENGTH	EACH	24/EA	48/EA
A05863-7030	3/0	1/64"	1/4"	\$1.92	\$1.73	\$1.64
A05863-7020	2/0	1/32"	17/64"	1.99	1.82	1.72
A05863-1000	0	1/32"	9/32"	2.11	1.90	1.80
A05863-1001	1	1/16"	3/8"	2.21	1.99	1.89
A05863-1002	2	1/16"	15/32"	2.40	2.16	2.05
A05863-1004	4	3/32"	21/32"	2.88	2.60	2.46
A05863-1006	6	1/8"	3/4"	3.37	3.03	2.88
A05863-1008	8	5/32"	15/16"	5.78	5.21	4.94
A05863-1010	10	7/32"	1"	7.52	6.77	6.42
A05863-1012	12	9/32"	1-1/16"	10.89	9.81	9.30

B Fan

NUMBER	SIZE	WIDTH	LENGTH	EACH	24/EA	48/EA
A05862-1002	2	1-11/32"	15/16"	\$5.49	\$4.94	\$4.67
A05862-1004	4	1-3/4"	1"	5.99	5.39	5.09
A05862-1006	6	1-3/4"	1-1/8"	7.79	6.99	6.62

C Blick® Scrubber Brushes SHORT handle
 Let's face it — everyone makes mistakes when watercolor painting. Luckily, these scrubber brushes with extra-stiff white nylon bristles are all you need to correct those mistakes. Simply rewet the area you want corrected, wait a few seconds, then scrub the paper, blot, and rework.

NUMBER	SIZE	WIDTH	LENGTH	EACH	12/EA
A06711-1002	2	5/32"	5/32"	\$7.90	\$7.11
A06711-1004	4	7/32"	3/16"	8.28	7.46
A06711-1006	6	1/4"	17/32"	9.20	8.28
A06711-1008	8	11/32"	11/32"	10.28	9.25
A06711-1012	12	7/16"	7/16"	11.51	10.36
A06711-1016	16	19/32"	5/8"	13.04	11.74

3-Brush Set — Sizes: 2, 6, and 12.
 NUMBER EACH 12/EA
 A06711-1039 \$24.25 \$21.82

Brushes shown actual size, except brush sets.

- better quality
- seamless nickel-plated ferrules
- lacquered natural wood handles



D-E Blick® Scholastic Wonder White SHORT handle
 Blick's Wonder White Taklon delivers the texture and responsiveness of red sable, yet stands up to paints and caustic solvents with greater durability. Flat Wash brushes have acrylic handles with a beveled end for scraping.

D Round

NUMBER	SIZE	DIA	LENGTH	EACH	12/EA	24/EA
A05857-7040	4/0	1/64"	3/16"	\$2.25	\$2.03	\$1.93
A05857-7030	3/0	1/64"	1/4"	2.25	2.03	1.93
A05857-7020	2/0	1/32"	1/4"	2.25	2.03	1.93
A05857-1000	0	1/32"	5/16"	2.35	2.12	1.99
A05857-1001	1	1/16"	3/8"	2.45	2.21	2.09
A05857-1002	2	1/16"	15/32"	2.65	2.36	2.49
A05857-1004	4	3/32"	11/16"	2.93	2.64	2.50
A05857-1006	6	1/8"	3/4"	3.23	2.91	2.76
A05857-1008	8	5/32"	15/16"	3.43	3.09	2.93
A05857-1010	10	7/32"	1"	4.22	3.80	3.61
A05857-1012	12	9/32"	1-3/16"	6.67	5.99	5.70
A05857-1014	14	5/16"	1-5/16"	8.35	7.52	7.15

Round Set of 6 — Sizes 0, 1, 2, 4, 6, and 8.
 NUMBER EACH 6/EA 12/EA
 A05857-0059 \$11.78 \$10.60 \$10.07

E Flat Foot

NUMBER	SIZE	WIDTH	LENGTH	EACH	12/EA	24/EA
A05856-4014	1/4"	1/4"	7/16"	\$7.65	\$6.89	\$6.55
A05856-4012	1/2"	1/2"	9/16"	10.60	9.53	9.06
A05856-4034	3/4"	3/4"	13/16"	15.22	13.70	12.99
A05856-1001	1"	1"	1"	20.13	18.12	17.20

Flat Foot 4-Brush Set — Sizes: 1/4", 1/2", 3/4", and 1".
 NUMBER EACH 6/EA 12/EA
 A05856-0049 \$48.79 \$43.90 \$41.72

F One-Stroke

NUMBER	SIZE	WIDTH	LENGTH	EACH	12/EA	24/EA
A05564-4014	1/4"	1/4"	25/32"	\$3.03	\$2.71	\$2.58
A05564-4012	1/2"	1/2"	29/32"	4.77	4.29	4.08
A05564-4034	3/4"	3/4"	1-3/32"	7.79	6.99	6.65
A05564-1001	1"	1"	1-5/16"	9.95	8.95	8.50

One-Stroke 4-Brush Set — Includes Sizes 1/4", 1/2", 3/4", and 1".
 NUMBER EACH 6/EA 12/EA
 A05564-0049 \$18.98 \$17.08 \$16.23



G-J Blick® Scholastic Golden Taklon SHORT handle
 Soft, short-handled brushes in striking Golden Taklon filament, perfectly balanced for watercolor painting. They deliver plenty of spring and good flow characteristics. Easily maneuverable, the Flat Foot shape features a clear acrylic handle with a flat end for scraping.

G Round

NUMBER	SIZE	DIA	LENGTH	EACH	12/EA	24/EA
A05858-7030	3/0	1/64"	1/4"	\$2.26	\$2.03	\$1.93
A05858-7020	2/0	1/32"	1/4"	2.26	2.03	1.93
A05858-1000	0	1/32"	5/16"	2.35	2.12	1.99
A05858-1001	1	1/16"	3/8"	2.53	2.28	2.17
A05858-1002	2	1/16"	15/32"	2.72	2.44	2.32
A05858-1004	4	3/32"	11/16"	3.17	2.85	2.71
A05858-1006	6	1/8"	3/4"	3.44	3.10	2.94
A05858-1008	8	5/32"	15/16"	3.90	3.50	3.33
A05858-1010	10	7/32"	1"	4.80	4.32	4.11
A05858-1012	12	9/32"	1-3/16"	5.44	4.89	4.65
A05858-1014	14	5/16"	1-5/16"	6.35	5.71	5.43
A05858-1016	16	3/8"	1-1/2"	7.71	6.93	6.59

Round 6-Brush Set — Sizes: 0, 1, 2, 4, 6, and 8.
 NUMBER EACH 6/EA 12/EA
 A05858-0069 \$15.60 \$14.05 \$13.35

H Flat Wash

NUMBER	SIZE	WIDTH	LENGTH	EACH	12/EA	24/EA
A05859-4014	1/4"	1/4"	15/32"	\$2.82	\$2.54	\$2.42
A05859-4012	1/2"	1/2"	9/32"	4.71	4.23	4.03
A05859-4034	3/4"	3/4"	13/16"	7.35	6.60	6.29
A05859-1001	1"	1"	1-1/16"	9.43	8.47	8.07

Flat Wash 4-Brush Set — Sizes: 1/4", 1/2", 3/4", and 1".
 NUMBER EACH 6/EA 12/EA
 A05859-0049 \$19.95 \$17.95 \$17.05

I Flat Foot

NUMBER	SIZE	LENGTH	EACH	12/EA	24/EA
A05860-4014	1/4"	7/16"	\$8.15	\$7.33	\$6.96
A05860-4012	1/2"	9/16"	11.80	10.61	10.07
A05860-4034	3/4"	13/16"	19.67	17.69	16.80
A05860-1001	1"	1"	25.72	23.13	21.96

Flat Foot 4-Brush Set — Sizes: 1/4", 1/2", 3/4", and 1".
 NUMBER EACH 6/EA 12/EA
 A05860-0049 \$54.62 \$49.15 \$46.69

J Fan

NUMBER	SIZE	WIDTH	LENGTH	EACH	12/EA	24/EA
A05861-1002	2	1-1/2"	15/16"	\$5.63	\$5.07	\$4.81
A05861-1004	4	1-3/4"	1-1/16"	5.92	5.32	5.06
A05861-1006	6	1-7/8"	1-3/16"	6.11	5.49	5.22

Fan 3-Brush Set — Sizes: 2, 4, and 6.
 NUMBER EACH 6/EA 12/EA
 A05861-0039 \$15.09 \$13.58 \$12.90

BLICK® academic

brushes for the advanced student

- quality craftsmanship
- seamless nickel-plated brass ferrules
- lacquered natural wood handles



K Blick® Academic Golden Taklon Round SHORT handle

Filaments of three diameters are assembled to produce a solid performer at a very affordable price. A time-tested brush with plenty of spring and good flow characteristics, these brushes also perform well with acrylic.

L Round

NUMBER	SIZE	DIA	LENGTH	EACH	6/EA
A05838-7040	4/0	1/64"	3/16"	\$5.99	\$5.39
A05838-7030	3/0	1/64"	7/32"	6.17	5.55
A05838-7020	2/0	1/32"	1/4"	6.44	5.79
A05838-1000	0	1/32"	9/32"	6.88	6.19
A05838-1001	1	1/16"	11/32"	9.53	8.57
A05838-1002	2	1/16"	15/32"	12.18	10.96
A05838-1004	4	3/32"	11/16"	14.56	13.10
A05838-1006	6	1/8"	23/32"	21.18	19.06
A05838-1008	8	5/32"	29/32"	30.90	27.80
A05838-1010	10	7/32"	15/16"	40.61	36.53
A05838-1012	12	9/32"	1-3/16"	56.50	50.83
A05838-1014	14	5/16"	1-3/8"	72.40	65.13

Round 5-Brush Set — Sizes: 0, 1, 2, 4, and 6.
 NUMBER EACH 3/EA
 A05838-0059 \$48.59 \$43.73

M Oval Wash

NUMBER	SIZE	DIA	LENGTH	EACH	6/EA
A05889-4014	1/4	1/4"	23/32"	\$12.28	\$11.05
A05889-4012	1/2	1/2"	29/32"	27.11	24.40
A05889-4034	3/4	3/4"	1-3/16"	46.60	41.94

6-Piece Round Set — Sizes: 0, 1, 2, 4, 6, and 8.
 NUMBER EACH 3/EA
 A05838-0069 \$30.84 \$27.77

Brushes shown actual size, except brush sets.

BLICK® studio

brushes for the professional artist

- excellent craftsmanship
- seamless nickel-plated brass ferrules
- varnished natural wood handles or clear acrylic handles



A-C Blick® Studio Synthetic SHORT handle

Premium "Sabeline" synthetic filaments in up to five diameters give this brush great fluid capacity and a so-soft, responsive touch that mimics sable convincingly. The look may even fool you as the hairs are dyed to give a more natural appearance. This is perhaps the best value in our line! Acrylic handles.

A Round

NUMBER	SIZE	DIA	LENGTH	EACH	12/EA
A05841-7030	3/0	1/64"	3/16"	\$5.64	\$5.08
A05841-7020	2/0	1/32"	1/4"	5.99	5.40
A05841-1000	0	1/32"	9/32"	6.37	5.73
A05841-1002	2	1/16"	7/16"	6.73	6.06
A05841-1004	4	3/32"	21/32"	7.45	6.71
A05841-1006	6	1/8"	3/4"	8.90	7.99
A05841-1008	8	5/32"	7/8"	10.86	9.77
A05841-1010	10	7/32"	31/32"	12.67	11.40
A05841-1012	12	9/32"	1-1/8"	16.29	14.66
A05841-1016	16	3/8"	1-1/2"	20.64	18.57
A05841-1020	20	9/16"	1-3/4"	45.62	41.06

B Wash

NUMBER	SIZE	WIDTH	LENGTH	EACH	12/EA
A05842-4012	1/2"	1/2"	19/32"	\$13.37	\$12.03
A05842-4034	3/4"	3/4"	13/16"	20.26	18.24
A05842-1001	1"	1"	1-1/32"	28.37	25.53

C Angular Wash

NUMBER	SIZE	WIDTH	LENGTH	EACH	12/EA
A05842-4134	3/4"	3/4"	29/32"	\$23.50	\$21.15

One Stroke Wash — (Not Shown)

NUMBER	SIZE	WIDTH	LENGTH	EACH	12/EA
A05842-4212	1/2"	1/2"	7/8"	\$11.34	\$10.21
A05842-4234	3/4"	3/4"	1-1/16"	17.42	15.68
A05842-1101	1"	1"	1-9/32"	23.50	21.15

Flat Wash — (Not Shown)

NUMBER	SIZE	WIDTH	LENGTH	EACH	12/EA
A05842-4112	1-1/2"	1-1/2"	1-17/32"	\$30.80	\$27.72

BLICK® masterstroke®

brushes for the professional artist

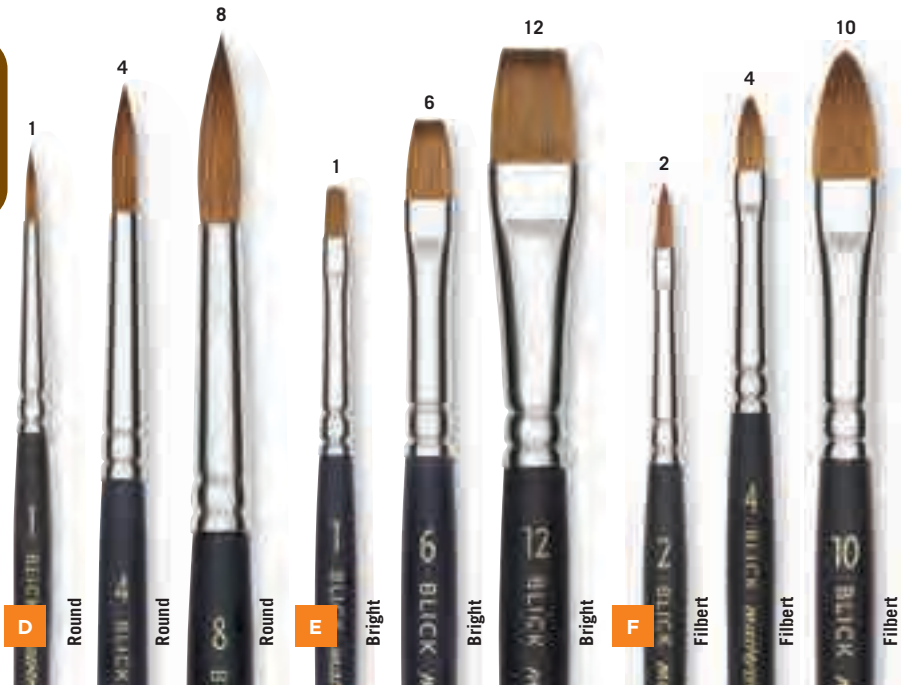

D-F Blick® Masterstroke® SHORT handle

Only the highest-quality brush hair finds its way into these brushes. Hand-selected and hand-cupped by skilled artisans, this highly resilient hair offers unsurpassed spring, snap, and control. The brush hairs are hand-glued into seamless, nickel-plated brass ferrules and securely crimped to matte black solid wood handles with distinctive gold tips.

D Round

NUMBER	SIZE	DIA	LENGTH	EACH	12/EA
A05457-1030	3/0	1/32"	7/32"	\$7.69	\$6.92
A05457-1000	00	3/64"	9/32"	8.05	7.24
A05457-1100	0	1/16"	3/8"	9.09	8.18
A05457-1001	1	5/64"	13/32"	11.20	10.07
A05457-1002	2	3/32"	7/16"	13.64	12.28
A05457-1003	3	7/65"	9/16"	20.30	18.26
A05457-1004	4	1/8"	5/8"	32.90	29.60
A05457-1005	5	9/64"	11/16"	45.50	40.94
A05457-1006	6	5/32"	13/16"	59.50	53.54
A05457-1008	8	3/16"	1"	69.99	62.98
A05457-1010	10	1/4"	1-1/16"	87.50	78.73
A05457-1012	12	5/16"	1-3/16"	111.99	100.78

E Bright

NUMBER	SIZE	WIDTH	LENGTH	EACH	12/EA
A05455-1001	1	1/8"	1/4"	\$10.44	\$9.39
A05455-1002	2	1/8"	5/16"	13.92	12.53
A05455-1004	4	7/32"	3/8"	22.15	19.93
A05455-1006	6	1/4"	7/16"	37.97	34.17
A05455-1008	8	9/32"	1/2"	47.47	42.71
A05455-1010	10	13/32"	17/32"	60.13	54.11
A05455-1012	12	7/16"	5/8"	66.46	59.80
A05455-1014	14	1/2"	21/32"	75.95	68.35

F Filbert

NUMBER	SIZE	WIDTH	LENGTH	EACH	12/EA
A05456-1001	1	3/32"	9/32"	\$9.14	\$8.23
A05456-1002	2	1/8"	5/16"	10.98	9.88
A05456-1003	3	3/16"	11/32"	16.10	14.50
A05456-1004	4	7/32"	13/32"	21.96	19.77
A05456-1006	6	1/4"	15/32"	25.62	23.06
A05456-1008	8	9/32"	9/16"	49.05	44.16
A05456-1010	10	13/32"	21/32"	65.89	59.32
A05456-1012	12	7/16"	3/4"	80.54	72.50
A05456-1014	14	1/2"	27/32"	87.86	79.10

Brushes shown actual size.

- superior craftsmanship
- seamless ferrules
- lacquered natural wood handles



Blick® Masterstroke® SHORT handle

Wonder White Rounds — Series 2026
Blick's Wonder White Taklon has a texture and responsiveness comparable to red sable, but with greater durability. The sharp point has good spring and is great for waterbased media (expect some staining of the filaments — it won't affect the performance of the brush, just the appearance).

NUMBER	SIZE	DIA	LENGTH	EACH	12/EA
A05018-7080	8/0	1/32"	13/64"	\$4.05	\$3.65
A05018-7030	3/0	3/64"	7/32"	4.11	3.70
A05018-7020	2/0	1/16"	1/4"	4.11	3.70
A05018-1000	0	5/64"	5/16"	4.27	3.85
A05018-1001	1	3/32"	3/8"	4.65	4.19
A05018-1002	2	7/64"	7/16"	5.05	4.55
A05018-1004	4	1/8"	9/16"	6.05	5.45
A05018-1006	6	5/32"	11/16"	7.38	6.65
A05018-1008	8	3/16"	7/8"	11.27	10.15
A05018-1010	10	7/32"	1"	13.83	12.45
A05018-1012	12	19/64"	1-3/16"	15.55	13.99
A05018-1014	14	21/64"	1-5/16"	17.10	15.39



Blick® Masterstroke® SHORT handle

Wonder White Round 6-Brush Set

Sizes: 2, 4, 6, 8, 10, and 12.

NUMBER	EACH	6/EA
A05018-9006	\$43.10	\$38.79

BLICK® masterstroke®

brushes for the professional artist



G-O Blick® Masterstroke® Golden Taklon SHORT handle

This professional grade of Golden Taklon features tapered filaments that mimic the belly and point of natural hair. A mix of diameters offers great control, point, and absorbency. Seamless stainless steel ferrules comply with non-hazardous standards.

G Round

NUMBER	SIZE	DIA	LENGTH	EACH	12/EA
A09015-7030	3/0	3/64"	5/16"	\$4.91	\$4.41
A09015-7020	2/0	3/64"	9/32"	4.91	4.41
A09015-1000	0	3/64"	5/16"	4.99	4.49
A09015-1001	1	1/16"	3/8"	5.08	4.56
A09015-1002	2	1/16"	7/16"	5.33	4.79
A09015-1004	4	1/8"	19/32"	6.18	5.55
A09015-1006	6	5/32"	23/32"	8.30	7.46
A09015-1008	8	7/32"	7/8"	8.89	7.99
A09015-1010	10	1/4"	1"	9.99	8.98
A09015-1012	12	5/16"	1-3/16"	12.11	10.88
A09015-1014	14	11/32"	1-5/16"	13.13	11.80

H Liner

NUMBER	SIZE	DIA	LENGTH	EACH	12/EA
A09016-7020	2/0	1/32"	3/8"	\$6.26	\$5.64
A09016-1000	0	3/64"	15/32"	6.35	5.71
A09016-1001	1	3/64"	7/16"	6.43	5.79

I Script Liner

NUMBER	SIZE	DIA	LENGTH	EACH	12/EA
A09014-1000	0	3/64"	13/16"	\$6.53	\$5.87
A09014-1001	1	3/64"	7/8"	6.78	6.10
A09014-1002	2	1/16"	15/16"	7.04	6.33

J Filbert

NUMBER	SIZE	WIDTH	LENGTH	EACH	12/EA
A09018-1002	2	1/8"	5/16"	\$7.20	\$6.48
A09018-1004	4	3/16"	3/8"	8.04	7.25
A09018-1006	6	7/32"	1/2"	8.89	7.99
A09018-1008	8	9/32"	9/16"	9.74	8.77

K Flat

NUMBER	SIZE	WIDTH	LENGTH	EACH	12/EA
A09017-5012	1/2"	1/2"	11/16"	\$7.20	\$6.48
A09017-5034	3/4"	3/4"	7/8"	12.11	10.91
A09017-1001	1"	1"	1-1/8"	14.82	13.35

L Chisel Blender

NUMBER	SIZE	WIDTH	LENGTH	EACH	12/EA
A09020-1004	4	5/32"	1/4"	\$7.45	\$6.71
A09020-1006	6	1/4"	9/32"	8.47	7.63
A09020-1008	8	5/16"	11/32"	8.81	7.93

M Shader

NUMBER	SIZE	WIDTH	LENGTH	EACH	12/EA
A09013-1002	2	3/32"	9/32"	\$6.61	\$5.94
A09013-1004	4	3/16"	3/8"	7.20	6.47
A09013-1006	6	7/32"	7/16"	8.05	7.23
A09013-1008	8	1/4"	1/2"	8.90	7.99
A09013-1010	10	3/8"	9/16"	9.57	8.60

N Angular Shader

NUMBER	SIZE	WIDTH	LENGTH	EACH	12/EA
A09012-5014	6	1/4"	11/32"	\$8.30	\$7.46
A09012-5038	8	3/8"	1/2"	8.98	8.07
A09012-5012	12	1/2"	19/32"	10.85	9.75

O Fan

NUMBER	SIZE	WIDTH	LENGTH	EACH	12/EA
A09019-1002	2	1-3/8"	13/16"	\$7.20	\$6.48
A09019-1004	4	1-11/16"	1"	9.14	8.24
A09019-1006	6	1-13/16"	1-3/16"	10.58	9.54



Robert Simmons® Simply Simmons Mixed Media Synthetic

SHORT handle

For students, amateurs, and professionals alike, Simply Simmons brushes offer excellent performance, dependability, and value — all at one low price, no matter the size. These brushes are handmade by skilled craftsmen to meet the same high standards that artists have come to expect from the Robert Simmons name.

Round

NUMBER	SIZE	DIA	LENGTH	EACH	12/EA
A06725-1000	0	5/64"	11/32"	\$4.65	\$4.19
A06725-1001	1	1/16"	7/16"	4.65	4.19
A06725-1002	2	3/32"	1/2"	4.65	4.19
A06725-1003	3	3/32"	1/2"	4.65	4.19
A06725-1004	4	7/64"	5/8"	4.65	4.19
A06725-1005	5	1/8"	23/32"	4.65	4.19
A06725-1006	6	5/32"	27/32"	4.65	4.19
A06725-1008	8	7/32"	31/32"	4.65	4.19
A06725-1010	10	1/4"	1-1/32"	4.65	4.19
A06725-1012	12	19/64"	1-5/16"	4.65	4.19

Liner

NUMBER	SIZE	DIA	LENGTH	EACH	12/EA
A06734-7100	10/0	1/32"	9/16"	\$4.65	\$4.19
A06734-7020	2/0	3/64"	17/32"	4.65	4.19
A06734-1000	0	1/16"	19/32"	4.65	4.19
A06734-1001	1	1/16"	5/8"	4.65	4.19
A06734-1002	2	5/64"	23/32"	4.65	4.19

Flat Shader

NUMBER	SIZE	WIDTH	LENGTH	EACH	12/EA
A06730-1002	2	1/8"	9/32"	\$4.65	\$4.19
A06730-1004	4	3/16"	11/32"	4.65	4.19
A06730-1006	6	7/32"	13/32"	4.65	4.19
A06730-1008	8	9/32"	1/2"	4.65	4.19
A06730-1010	10	3/8"	9/16"	4.65	4.19
A06730-1012	12	13/32"	21/32"	4.65	4.19

Flat Wash

NUMBER	SIZE	WIDTH	LENGTH	EACH	12/EA
A06733-4012	1/2"	1/2"	11/16"	\$4.65	\$4.19
A06733-4034	3/4"	3/4"	27/32"	4.65	4.19
A06733-1001	1"	1"	1-1/32"	4.65	4.19

Filbert

NUMBER	SIZE	WIDTH	LENGTH	EACH	12/EA
A06729-1004	4	5/32"	3/8"	\$4.65	\$4.19
A06729-1006	6	7/32"	15/32"	4.65	4.19
A06729-1008	8	9/32"	1/2"	4.65	4.19
A06729-1010	10	9/16"	13/32"	4.65	4.19

Angle Shader

NUMBER	SIZE	WIDTH	LENGTH	EACH	12/EA
A06732-4018	1/8"	1/8"	17/64"	\$4.65	\$4.19
A06732-4014	1/4"	1/4"	25/64"	4.65	4.19
A06732-4038	3/8"	3/8"	15/32"	4.65	4.19
A06732-4012	1/2"	1/2"	1/2"	4.65	4.19
A06732-4058	5/8"	5/8"	45/64"	4.65	4.19
A06732-4034	3/4"	3/4"	53/64"	4.65	4.19

Angle Comb

NUMBER	SIZE	WIDTH	LENGTH	EACH	12/EA
A06731-4014	1/4"	1/4"	29/64"	\$4.65	\$4.19
A06731-4034	3/8"	3/8"	1/4"	4.65	4.19
A06731-4012	1/2"	1/2"	3/8"	4.65	4.19

Flat Comb

NUMBER	SIZE	WIDTH	LENGTH	EACH	12/EA
A06727-4012	1/2"	1/2"	5/8"	\$4.65	\$4.19
A06727-4058	5/8"	5/8"	3/4"	4.65	4.19
A06727-4034	3/4"	3/4"	13/16"	4.65	4.19

Filbert Comb

NUMBER	SIZE	WIDTH	LENGTH	EACH	12/EA
A06728-1006	6	15/64"	15/32"	\$4.65	\$4.19
A06728-1008	8	9/32"	33/64"	4.65	4.19
A06728-1010	10	25/64"	35/64"	4.65	4.19

One Stroke

NUMBER	SIZE	WIDTH	LENGTH	EACH	12/EA
A06404-4012	1/2"	1/2"	31/32"	\$4.65	\$4.19
A06404-4034	3/4"	3/4"	1-9/32"	4.65	4.19
A06404-1001	1"	1"	63/64"	4.65	4.19

Spotter

NUMBER	SIZE	WIDTH	LENGTH	EACH	12/EA
A06726-7100	10/0	7/32"	1/32"	\$4.65	\$4.19
A06726-0000	5/0	3/64"	15/64"	4.65	4.19
A06726-7030	3/0	3/64"	9/32"	4.65	4.19

Script — (not shown)

NUMBER	SIZE	DIA	LENGTH	EACH	12/EA
A06735-1001	1	1/16"	21/32"	\$4.65	\$4.19
A06735-1003	3	5/64"	1"	4.65	4.19

Sword — (not shown)

NUMBER	SIZE	WIDTH	LENGTH	EACH	12/EA
A06398-4014	1/4"	1/4"	35/64"	\$4.65	\$4.19
A06398-4038	3/8"	3/8"	25/32"	4.65	4.19
A06398-4012	1/2"	1/2"	15/16"	4.65	4.19

Fan Blender — (not shown)

NUMBER	SIZE	WIDTH	LENGTH	EACH	12/EA
A06736-1002	2	1-1/2"	29/32"	\$4.65	\$4.19
A06736-1004	4	1-11/16"	1-7/32"	4.65	4.19

Brushes shown actual size, except brush sets.



A-F Princeton™ Snap!™ Golden Taklon Brushes

SHORT handle

Fun, but not frivolous, Snap! Brushes are high-quality artist tools. Designed from the neck down, their colorful handles feature unique, multi-colored designs. This is a great series of value-priced, short-handle brushes for watercolorists, decorative painters, and acrylic artists.

A Round

NUMBER	SIZE	DIA	LENGTH	EACH	6/EA
A06237-7030	3/0	3/64"	15/64"	\$3.30	\$2.97
A06237-1002	2	3/32"	15/32"	3.30	2.97
A06237-1004	4	1/8"	45/64"	5.15	4.63
A06237-1006	6	5/32"	3/4"	5.15	4.63
A06237-1010	10	1/4"	1-1/16"	6.57	5.91
A06237-1012	12	5/16"	1-17/64"	6.57	5.91
A06237-1016	16	3/8"	1-3/8"	8.06	7.23
A06237-1020	20	7/16"	1-29/64"	8.06	7.23

B Angle Shader

NUMBER	SIZE	WIDTH	LENGTH	EACH	6/EA
A06254-4014	1/4"	1/4"	11/32"	\$3.30	\$2.97
A06254-4012	1/2"	1/2"	5/8"	5.15	4.63
A06254-4034	3/4"	3/4"	15/16"	6.57	5.91

C Filbert

NUMBER	SIZE	WIDTH	LENGTH	EACH	6/EA
A06234-1004	4	3/16"	25/64"	\$3.30	\$2.97
A06234-1008	8	11/32"	5/8"	5.15	4.63
A06234-1012	12	25/64"	53/64"	6.57	5.91

D Liner

NUMBER	SIZE	WIDTH	LENGTH	EACH	6/EA
A06235-1002	2	1/16"	25/32"	\$3.30	\$2.97

E Oval Wash

NUMBER	SIZE	WIDTH	LENGTH	EACH	6/EA
A06236-4034	3/4"	43/64"	1-37/64"	\$8.06	\$7.23

F Stroke

NUMBER	SIZE	WIDTH	LENGTH	EACH	6/EA
A06238-4012	1/2"	1/2"	3/4"	\$5.15	\$4.63
A06238-4034	3/4"	3/4"	3/4"	6.57	5.91
A06238-1001	1"	1"	1-17/64"	8.06	7.23

Wash — (not shown)

NUMBER	SIZE	WIDTH	LENGTH	EACH	6/EA
A06239-1001	1"	1"	1-17/64"	\$8.06	\$7.23



Set 1 — Includes Size 10 Round, Size 3/4" Angle Shader, and Size 8 Filbert.

NUMBER	EACH	6/EA
A06240-1009	\$12.33	\$11.10

Set 2 — Includes Size 6 Round and Size 4 Round.

NUMBER	EACH	6/EA
A06240-2009	\$12.33	\$11.10

G-L Princeton™ Snap!™ White Soft Synthetic

SHORT handle

These value-priced, high-quality artist tools with short handles and white taklon brush filaments are available in a wide variety of shapes and sizes. For watercolorists, decorative painters, and acrylic artists.

G Round

NUMBER	SIZE	DIA	LENGTH	EACH	6/EA
A06251-7020	2/0	1/16"	5/16"	\$3.26	\$2.93
A06251-1000	0	5/64"	23/64"	3.26	2.93
A06251-1002	2	7/64"	23/64"	3.26	2.93
A06251-1004	4	9/64"	43/64"	5.08	4.57
A06251-1006	6	5/32"	3/4"	5.08	4.57
A06251-1010	10	1/4"	1-1/16"	6.48	5.83
A06251-1012	12	5/16"	1-17/64"	6.48	5.83
A06251-1020	20	7/16"	1-1/2"	7.95	7.15

H Bright Shader

NUMBER	SIZE	WIDTH	LENGTH	EACH	6/EA
A06242-1004	4	7/32"	15/64"	\$3.26	\$2.93
A06242-1006	6	9/32"	17/64"	5.08	4.57
A06242-1010	10	25/64"	25/64"	6.48	5.83

I Fan

NUMBER	SIZE	WIDTH	LENGTH	EACH	6/EA
A06243-1004	4	1-13/16"	1-19/64"	\$5.08	\$4.57

J Flat Shader

NUMBER	SIZE	WIDTH	LENGTH	EACH	6/EA
A06244-1006	6	1/4"	15/32"	\$5.08	\$4.57
A06244-1010	10	11/32"	33/64"	6.48	5.83
A06244-1016	16	15/32"	3/4"	7.95	7.15

K Liner

NUMBER	SIZE	DIA	LENGTH	EACH	6/EA
A06252-1004	4	1/16"	53/64"	\$3.26	\$2.93

L Stroke

NUMBER	SIZE	WIDTH	LENGTH	EACH	6/EA
A06250-1001	1"	1"	1-19/64"	\$7.95	\$7.15

Angle Shader — (not shown)

NUMBER	SIZE	WIDTH	LENGTH	EACH	6/EA
A06241-4034	3/4"	3/4"	25/32"	\$6.48	\$5.83
A06241-1001	1"	1"	1"	7.95	7.15



Set of 4 — Includes Sizes 0, 2, and 6 Round, and 3/4" Angle Shader.

NUMBER	EACH	6/EA
A06240-3009	\$12.33	\$11.10

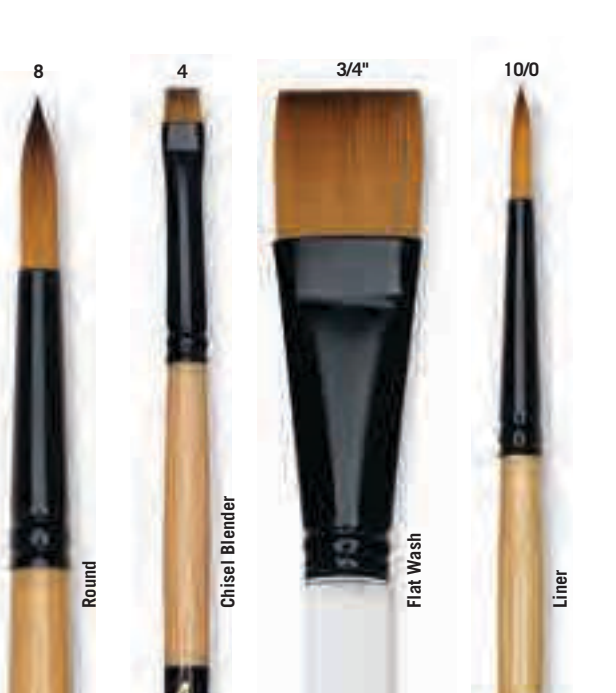

Dynasty™ Black Gold

SHORT handle

These expertly handcrafted brushes are fitted with quality synthetic bristles that offer superior control and performance. Every two-tone varnished handle, short or long, is kiln-dried for durability and carries the "Black Gold" imprint. The seamless black ferrules provide safe, long-lasting, water-resistant beauty.

Round

NUMBER	SIZE	DIA.	LENGTH	EACH	12/EA
A06312-7100	10/0	1/64"	5/32"	\$3.83	\$3.45
A06312-7050	5/0	1/32"	13/64"	3.83	3.45
A06312-7030	3/0	3/64"	15/64"	3.83	3.45
A06312-7020	2/0	3/64"	9/32"	3.83	3.45
A06312-1000	0	1/16"	5/16"	3.99	3.59
A06312-1001	1	1/16"	3/8"	4.40	3.96
A06312-1002	2	5/64"	33/64"	4.77	4.29
A06312-1004	4	7/64"	43/64"	5.35	4.82
A06312-1006	6	5/32"	45/64"	7.08	6.37
A06312-1008	8	3/16"	63/64"	10.05	9.05
A06312-1010	10	15/64"	1-1/16"	12.70	11.43
A06312-1012	12	19/64"	1-7/32"	14.35	12.92
A06312-1014	14	21/64"	1-17/64"	16.18	14.56

Angular — (not shown)

NUMBER	SIZE	WIDTH	LENGTH	EACH	12/EA
A06300-4018	1/8"	1/8"	1/4"	\$5.42	\$4.88
A06300-4014	1/4"	1/4"	11/32"	6.99	6.29
A06300-4038	3/8"	3/8"	7/16"	8.52	7.67
A06300-4012	1/2"	1/2"	43/64"	9.39	8.45
A06300-4034	3/4"	3/4"	53/64"	13.40	12.06
A06300-1001	1"	1"	1-9/64"	16.90	15.20

Chisel Blender

NUMBER	SIZE	WIDTH	LENGTH	EACH	12/EA
A06301-1000	0	5/64"	1/8"	\$4.70	\$4.23
A06301-1002	2	9/64"	9/64"	5.25	4.73
A06301-1004	4	3/16"	3/16"	5.49	4.94
A06301-1006	6	7/32"	15/64"	6.35	5.71
A06301-1008	8	1/4"	11/32"	7.05	6.35
A06301-1010	10	3/8"	25/64"	8.15	7.35
A06301-1012	12	7/16"	7/16"	9.73	8.75
A06301-1014	14	15/32"	15/32"	11.45	10.30
A06301-1016	16	35/64"	33/64"	12.53	11.28
A06301-1018	18	5/8"	19/32"	13.73	12.35
A06301-1020	20	43/64"	43/64"	14.88	13.39

Flat Wash

NUMBER	SIZE	WIDTH	LENGTH	EACH	12/EA
A06306-4014	1/4"	7/32"	3/8"	\$7.55	\$6.79
A06306-4012	1/2"	15/32"	43/64"	8.95	8.05
A06306-4034	3/4"	25/32"	25/32"	13.80	12.45
A06306-1001	1"	1"	1-1/16"	18.99	17.09

Liner

NUMBER	SIZE	WIDTH	LENGTH	EACH	12/EA
A06308-7100	10/0	1/32"	1/4"	\$3.83	\$3.45
A06308-7050	5/0	1/32"	23/64"	3.83	3.45
A06308-1000	0	3/64"	15/32"	3.86	3.47
A06308-1001	1	1/16"	15/32"	4.40	3.96
A06308-1002	2	5/64"	33/64"	4.79	4.31
A06308-1004	4	7/64"	5/8"	5.33	4.79



Princeton™ Lauren™ Synthetic Golden Taklon Series 4350

SHORT handle

A quality, short handle brush for the watercolor painter with good color-holding capacity. It lays out larger areas as well as issuing fluid watercolor applications. A great value, this durable brush is economically priced for students and hobbyists. This series of Princeton brushes features a rich, distinctive gold ferrule and green hardwood handle.

Round

NUMBER	SIZE	DIA	LENGTH	EACH	12/EA
A06157-7050	5/0	1/64"	3/16"	\$3.60	\$3.23
A06157-7030	3/0	1/32"	1/8"	3.71	3.34
A06157-7020	2/0	1/16"	5/16"	3.78	3.40
A06157-1000	0	1/16"	3/8"	3.97	3.57
A06157-1001	1	3/32"	3/8"	4.19	3.77
A06157-1002	2	3/32"	7/16"	4.49	4.04
A06157-1004	4	1/8"	3/4"	5.03	4.51
A06157-1006	6	3/16"	13/16"	6.78	6.10
A06157-1008	8	1/4"	7/8"	8.50	7.65
A06157-1010	10	5/16"	1-1/16"	11.12	9.99
A06157-1012	12	3/8"	1-3/16"	14.53	13.07
A06157-1016	16	7/16"	1-1/4"	15.47	13.91

Flat

NUMBER	SIZE	WIDTH	LENGTH	EACH	12/EA
A06121-1004	4	3/16"	3/8"	\$6.71	\$6.03
A06121-1010	10	5/16"	1/2"	10.65	9.58

Flat Wash

NUMBER	SIZE	WIDTH	LENGTH	EACH	12/EA
A06155-4112	12	1-1/2"	1-9/16"	\$22.97	\$20.67

Wash — (not shown)

NUMBER	SIZE	WIDTH	LENGTH	EACH	12/EA
A06159-4012	1/2"	1/2"	2/3"	\$11.13	\$9.99
A06159-4034	3/4"	3/4"	7/8"	16.23	14.60
A06159-1001	1"	1"	1"	22.13	19.91

Angle Shader

NUMBER	SIZE	WIDTH	LENGTH	EACH	12/EA
A06118-4114	1/4"	1/4"	3/8"	\$5.99	\$5.40
A06118-4112	1/2"	1/2"	2/3"	8.62	7.76
A06174-4034	3/4"	3/4"	7/8"	15.67	14.10

Fan

NUMBER	SIZE	WIDTH	LENGTH	EACH	12/EA
A06120-1004	4	1-1/2"	1"	\$4.72	\$4.25

Liner

NUMBER	SIZE	WIDTH	LENGTH	EACH	12/EA
A06156-1002	2	1/32"	3/4"	\$4.68	\$4.21
A06156-1004	4	1/16"	7/8"	5.18	4.66

Filbert

NUMBER	SIZE	WIDTH	LENGTH	EACH	12/EA
A06119-1004	4	3/16"	3/8"	\$5.75	\$5.18
A06119-1006	6	10/32"	1/2"	6.23	5.61

Stroke — (not shown)

NUMBER	SIZE	WIDTH	LENGTH	EACH	12/EA
A06158-4014	1/4"	1/4"	2/3"	\$6.96	\$6.27
A06158-4012	1/2"	1/2"	3/4"	8.68	7.81
A06158-4034	3/4"	3/4"	1"	10.39	9.35
A06158-1001	1"	1"	1-1/4"	13.89	12.50



Princeton™ Select™ Series 3750 Synthetic

SHORT handle

The Princeton Select line of brushes goes beyond the basic brush shapes and sizes that make up the artist's arsenal. Exciting technique brushes join a range of high-quality Rounds, Filberts, Flats, Chisel Blenders, Liners, and more.

Round — (*indicates mini brush)

NUMBER	SIZE	DIA	LENGTH	EACH	12/EA
A06389-1120	20/0	1/16"	3/16" *	\$3.72	\$3.34
A06389-1112	12/0	1/16"	3/16" *	3.72	3.34
A06389-1105	5/0	1/16"	1/4" *	3.72	3.34
A06389-1000	0	1/16"	3/8"	3.79	3.40
A06389-1001	1	1/16"	7/16"	3.86	3.47
A06389-1002	2	1/16"	1/2"	3.93	3.53
A06389-1003	3	1/16"	5/8"	4.07	3.66
A06389-1004	4	1/8"	11/16"	4.14	3.72
A06389-1005	5	1/8"	3/4"	4.21	3.78
A06389-1006	6	1/8"	3/16"	4.49	4.03
A06389-1008	8	3/16"	15/16"	5.81	5.22
A06389-1010	10	1/4"	1"	6.43	5.78
A06389-1012	12	1/4"	1-1/8"	8.17	7.34

Flat Shader — (*indicates mini brush)

NUMBER	SIZE	WIDTH	LENGTH	EACH	12/EA
A06384-1000	0	1/8"	1/4" *	\$3.72	\$3.34
A06384-1002	2	1/8"	9/32"	3.72	3.34
A06384-1004	4	7/32"	11/32"	3.93	3.53
A06384-1006	6	1/4"	3/8"	4.28	3.84
A06384-1008	8	11/32"	15/32"	5.94	5.34
A06384-1010	10	3/8"	9/16"	8.17	7.34
A06384-1012	12	1/4"	5/8"	8.45	7.59

Flat Wash — (not shown)

NUMBER	SIZE	WIDTH	LENGTH	EACH	12/EA
A06386-4012	1/2"	1/2"	5/8"	\$8.17	\$7.34
A06386-4034	3/4"	3/4"	7/8"	9.70	8.72
A06386-1001	1"	31/32"	1-3/32"	11.09	9.97

Filbert — (*indicates mini brush)

NUMBER	SIZE	WIDTH	LENGTH	EACH	12/EA
A06376-1000	0	3/32"	3/16" *	\$3.72	\$3.34
A06383-1002	2	3/32"	5/16"	3.72	3.34
A06383-1004	4	3/16"	7/16"	3.93	3.53
A06383-1006	6	1/4"	15/32"	4.28	3.84
A06383-1008	8	7/16"	9/16"	5.94	5.34
A06383-1010	10	3/8"	5/8"	8.17	7.34
A06383-1012	12	11/16"	23/32"	8.69	7.81

Filbert Grainer — (not shown)

NUMBER	SIZE	WIDTH	LENGTH	EACH	12/EA
A06385-4014	1/4"	1/4"	1/2"	\$4.42	\$3.97
A06385-4012	1/2"	1/2"	3/4"	8.17	7.34
A06385-4038	3/8"	3/8"	19/32"	5.94	5.34
A06385-4034	3/4"	3/4"	31/32"	9.70	8.72

Script Liner — (not shown)

NUMBER	SIZE	DIA	LENGTH	EACH	12/EA
A06390-7010	10/0	1/16"	23/32"	\$3.72	\$3.34
A06390-7002	2/0	1/16"	27/32"	3.79	3.40
A06390-1001	1	3/32"	31/32"	3.93	3.53
A06390-1002	2	3/32"	1-1/8"	4.07	3.66

Fan — (not shown)

NUMBER	SIZE	WIDTH	LENGTH	EACH	12/EA
A06086-1020	20/0	19/32"	9/32"	\$3.72	\$3.34
A06376-1002	2	1-9/16"	29/32"	5.94	5.34

Short Liner

NUMBER	SIZE	DIA	LENGTH	EACH	12/EA
A06391-7018	18/0	1/32"	7/32"	\$3.72	\$3.34

Oval Mop

NUMBER	SIZE	DIA	LENGTH	EACH	12/EA
A06392-4014	1/4	1/4"	15/32"	\$5.22	\$4.69
A06392-4012	1/2	1/2"	7/8"	8.17	7.34
A06392-4034	3/4	43/64"	1-1/8"	9.70	8.72
A06392-1001	1	31/32"	1-5/16"	11.16	10.03

Angle Shader

NUMBER	SIZE	WIDTH	LENGTH	EACH	12/EA
A06381-4018	1/8	1/8"	1/4"	\$3.72	\$3.34
A06381-4014	1/4	1/4"	3/8"	4.14	3.72
A06381-4038	3/8	3/8"	1/2"	5.74	5.16
A06381-4012	1/2	1/2"	5/8"	8.10	7.28
A06381-4058	5/8	5/8"	3/4"	9.56	8.59

Liner — (*indicates mini brush)

NUMBER	SIZE	DIA	LENGTH	EACH	12/EA
A06388-1020	20/0	1/32"	3/8" *	\$3.72	\$3.34
A06388-7010	10/0	1/16"	1/2"	3.72	3.34
A06388-1000	0	1/16"	19/32"	3.79	3.40
A06388-1001	1	1/16"	5/8"	3.86	3.47
A06388-1002	2	3/32"	21/32"	3.93	3.53
A06388-1006	6	3/32"	7/8"	4.14	3.72

Chisel Blender

NUMBER	SIZE	WIDTH	LENGTH	EACH	12/EA
A06382-1002	2	3/16"	11/64"	\$3.72	\$3.34
A06382-1004	4	3/16"	1/4"	4.00	3.59
A06382-1006	6	7/32"	9/32"	4.28	3.84
A06382-1008	8	21/64"	11/32"	5.94	5.34
A06382-1010	10	25/64"	25/64"	8.17	7.34
A06382-1012	12	7/16"	15/32"	8.45	7.59

Spotter — (*indicates mini brush)

NUMBER	
--------	--



Princeton™ Velvetouch™ Series 3950 Synthetic Blend SHORT handle

Containing a blend of luxurious NextGen synthetic filaments, Princeton Velvetouch brushes are the ultimate mixed media tool for watercolors, acrylics, and oil paints. The line includes both traditional shapes and specialty brushes. Soft-finish wood handles complement the enhanced performance and experience of the unique filaments, resulting in a brush that feels as good in the hand as it does when applying paint to paper, canvas, and other surfaces.

NUMBER	SIZE	WIDTH	LENGTH	EACH	3/EA
Filbert *					
A06429-1004	4	3/16"	3/8"	\$5.51	\$4.96
A06429-1006	6	1/4"	1/2"	6.33	5.69
A06429-1008	8	1/4"	9/16"	7.15	6.43
A06429-1000	0	1/8"	5/16" *	6.15	5.53
Filbert Grainer *					
A06430-1038	3/8"	3/8"	5/8"	\$8.89	\$7.99
A06430-1014	1/4"	17/64"	31/64" *	8.11	7.29
Chisel Blender *					
A06427-1002	2	3/16"	3/16"	\$4.17	\$3.76
A06427-1004	4	3/16"	1/4"	4.80	4.32
A06427-1006	6	1/4"	1/4"	5.28	4.75
A06427-1008	8	5/16"	5/16"	6.05	5.45
A06427-1000	0	5/64"	1/8" *	6.17	5.55
Angular Shader *					
A06426-1018	1/8"	3/16"	3/16"	\$5.94	\$5.38
A06426-1014	1/4"	5/16"	5/16"	6.36	5.75
A06426-1038	3/8"	3/8"	3/8"	6.99	6.32
A06426-1012	1/2"	15/32"	25/64"	7.92	7.16
A06426-1058	5/8"	19/32"	29/64"	8.84	7.99
A06426-1016	1/16"	5/64"	7/64" *	6.18	5.59
Flat Shader *					
A06431-1002	2	3/16"	1/4"	\$4.93	\$4.46
A06431-1004	4	3/16"	3/8"	5.29	4.78
A06431-1006	6	1/4"	7/16"	6.06	5.48
A06431-1008	8	1/4"	1/2"	6.42	5.81
A06431-1010	10	3/8"	9/16"	6.99	6.32
A06431-1000	10/0	1/32"	1/8" *	4.93	4.46
A06431-1100	0	1/8"	7/32" *	4.93	4.46
Liner *					
A06432-1100	10/0	1/16"	1/2"	\$4.25	\$3.83
A06432-1200	20/0	1/32"	25/64" *	4.89	4.40
A06432-1001	1	1/32"	45/64" *	4.89	4.40
Short Liner — (not shown)					
A06437-1180	18/0	1/16"	5/16"	\$4.55	\$4.09
A06437-1100	10/0	1/32"	23/64"	4.61	4.15
Script Liner					
A06436-1020	2/0	1/16"	5/8"	\$4.55	\$4.09
A06436-1002	2	1/16"	53/64"	4.55	4.09
Spotter *					
A06438-1180	18/0	1/16"	1/8"	\$4.28	\$3.84
A06438-1050	5/0	1/16"	3/16"	4.55	4.09
A06438-1200	20/0	1/64"	7/64" *	4.73	4.26
A06438-1030	3/0	1/32"	13/64" *	4.79	4.31
Fan *					
A06428-1100	10/0	15/16"	7/16"	\$6.36	\$5.73
A06428-1200	20/0	51/64"	19/64" *	6.36	5.73
Round *					
A06435-1180	18/0	1/16"	3/16"	\$4.28	\$3.85
A06435-1030	3/0	1/32"	17/64"	4.44	3.99
A06435-1001	1	1/16"	3/8"	4.74	4.26
A06435-1002	2	1/16"	1/2"	5.05	4.54
A06435-1003	3	7/64"	35/64"	5.26	4.73
A06435-1004	4	1/8"	5/8"	5.39	4.84
A06435-1005	5	1/8"	43/64"	5.72	5.14
A06435-1006	6	3/16"	3/4"	6.52	5.86
A06435-1008	8	1/4"	7/8"	7.62	6.85
A06435-1010	10	7/32"	15/16"	8.99	8.09
A06435-1200	20/0	1/32"	3/16" *	4.44	3.99
A06435-1120	12/0	1/64"	13/64" *	4.62	4.15
A06435-1000	0	3/64"	5/16" *	4.68	4.21
Long Round					
A06433-1002	2	5/64"	19/32"	\$6.36	\$5.75
A06433-1004	4	1/8"	3/4"	6.99	6.32
A06433-1006	6	3/16"	13/16"	8.30	7.51
A06433-1008	8	1/4"	1"	9.59	8.67
A06433-1010	10	1/4"	1-1/8"	10.99	9.97
A06433-1012	12	5/8"	1-5/16"	11.99	10.86
A06433-1014	14	5/16"	1-34/64"	13.44	12.16
Wash					
A06439-1012	1/2"	15/32"	11/16"	\$7.99	\$7.20
A06439-1034	3/4"	3/4"	13/16"	11.42	10.27
A06439-1001	1"	1"	1"	13.67	12.30
Oval Mop *					
A06434-1014	1/4"	15/64"	43/64"	\$8.38	\$7.54
A06434-1012	1/2"	27/64"	1-7/32"	10.98	9.88
A06434-1034	3/4"	1-5/8"	1-9/16"	13.03	11.72
A06452-1018	1/8"	13/64"	29/64" *	7.41	6.67
Willow's Blender *					
A06454-1014	1/4"	7/32"	1/4"	\$6.36	\$5.73
A06454-1038	3/8"	11/32"	6/64"	6.99	6.30
A06454-1018	1/8"	7/64"	9/64" *	6.30	5.68
Stroke					
A06453-1014	1/4"	15/64"	45/64"	\$6.18	\$5.56
A06453-1012	1/2"	15/32"	61/64"	7.99	7.21

Royal & Langnickel' Zen™ All Media Brushes LONG handle SHORT handle

Lightweight and easy to handle, Zen brushes are optimized for a smooth and accurate brushstroke. Appropriate for all media, the synthetic multi-diameter filaments form excellent points and chisel edges, while the acrylic handles have a unique silver mirror finish that is durable, waterproof, and easy to clean. The handles won't crack or peel when left in water. Every brush has a beveled end that can be used as a tool.

NUMBER	SIZE	WIDTH	LENGTH	EACH	6/EA
Series 43 Long Handle Round					
A09149-2001	1	5/32"	5/8"	\$3.76	\$3.38
A09149-2002	2	7/32"	11/16"	4.99	4.50
A09149-2004	4	1/4"	7/8"	4.99	4.50
A09149-2006	6	5/16"	1-1/8"	6.27	5.64
A09149-2008	8	13/32"	1-5/16"	6.27	5.64
A09149-2010	10	15/32"	1-3/8"	7.52	6.77
A09149-2012	12	1/2"	1-9/16"	7.52	6.77
Series 43 Long Handle Flat					
A09149-6001	1	3/16"	1/2"	\$3.76	\$3.38
A09149-6002	2	9/32"	5/8"	4.99	4.50
A09149-6004	4	3/8"	13/16"	4.99	4.50
A09149-6006	6	1/2"	15/16"	6.27	5.64
A09149-6008	8	5/8"	1-3/32"	6.27	5.64
A09149-6010	10	3/4"	1-5/16"	7.52	6.77
A09149-6012	12	1"	1-1/2"	7.52	6.77
Series 43 Long Handle Filbert					
A09149-1001	1	7/32"	1/2"	\$3.76	\$3.38
A09149-1002	2	9/32"	21/32"	4.99	4.50
A09149-1004	4	3/8"	13/16"	4.99	4.50
A09149-1006	6	1/2"	1"	6.27	5.64
A09149-1008	8	5/8"	1-1/8"	6.27	5.64
A09149-1010	10	3/4"	1-1/4"	7.52	6.77
A09149-1012	12	1"	1-1/2"	7.52	6.77
Series 43 Long Handle Bright					
A09149-4001	1	7/32"	5/16"	\$3.76	\$3.38
A09149-4002	2	9/32"	3/8"	4.99	4.50
A09149-4004	4	3/8"	19/32"	4.99	4.50
A09149-4006	6	1/2"	11/16"	6.27	5.64
A09149-4008	8	5/8"	13/16"	6.27	5.64
A09149-4010	10	1"	1-1/16"	7.52	6.77
A09149-4012	12	1"	1-1/16"	7.52	6.77
Series 43 Long Handle Angular					
A09149-3002	2	9/32"	7/16"	\$4.99	\$4.50
A09149-3004	4	13/32"	5/8"	4.99	4.50
A09149-3006	6	1/2"	3/4"	6.27	5.64
A09149-3008	8	5/8"	15/16"	6.27	5.64
A09149-3010	10	3/4"	1"	7.52	6.77
Series 73 Long Handle Fan					
A09149-5002	2	1-3/8"	3/4"	\$4.99	\$4.50
A09149-5004	4	1-5/8"	7/8"	4.99	4.50
A09149-5006	6	2-1/4"	1"	6.27	5.64
Series 73 Short Handle Flat Shaper					
A09148-1002	2	1/8"	11/32"	\$3.70	\$3.33
A09148-1004	4	3/16"	7/16"	3.70	3.33
A09148-1006	6	7/32"	1/2"	4.99	4.50
A09148-1008	8	5/16"	5/8"	4.99	4.50
A09148-1010	10	3/8"	11/16"	4.99	4.50
A09148-1012	12	3/8"	13/16"	4.99	4.50
Series 73 Short Handle One Stroke					
A09148-1112	1/2"	1/2"	1"	\$6.27	\$5.64
A09148-1134	3/4"	3/4"	1-1/4"	6.27	5.64
A09148-1101	1"	1"	1-1/4"	7.52	6.77
Series 73 Short Handle Round					
A09148-2001	1	1/16"	3/8"	\$3.70	\$3.33
A09148-2002	2	3/32"	1/2"	3.70	3.33
A09148-2003	3	1/8"	9/16"	3.70	3.33
A09148-2004	4	1/8"	1/4"	3.70	3.33
A09148-2005	5	3/16"	11/16"	4.99	4.50
A09148-2006	6	3/16"	13/16"	4.99	4.50
A09148-2008	8	7/32"	7/8"	4.99	4.50
A09148-2010	10	1/4"	1"	4.99	4.50
A09148-2012	12	9/32"	1-1/8"	4.99	4.50
Series 73 Short Handle Flat Wash					
A09148-8012	1/2"	1/2"	5/8"	\$6.27	\$5.64
A09148-8034	3/4"	3/4"	7/8"	6.27	5.64
A09148-8001	1"	1"	1-1/16"	7.52	6.77
Series 73 Short Handle Oval Wash					
A09148-9012	1/2"	1/2"	1 1/16"	\$6.27	\$5.64
A09148-9034	3/4"	3/4"	1-1/4"	6.27	5.64
A09148-9001	1"	1"	1-7/16"	7.52	6.77
Series 73 Short Handle Script					
A09148-7200	20/0	3/64"	13/32"	\$2.93	\$2.77
A09148-7100	10/0	1/16"	9/16"	2.93	2.77
A09148-7001	1	5/64"	15/16"	3.70	3.33
Series 73 Short Handle Flat Shader					
A09148-3000	0	7/32"	1/2"	\$3.70	\$3.33
A09148-3002	2	9/64"	5/16"	3.70	3.33
A09148-3004	4	3/16"	3/8"	3.70	3.33
A09148-3006	6	15/64"	7/16"	4.99	4.50
A09148-3010	10	1/4"	1/2"	4.99	4.50
A09148-3012	12	21/64"	9/16"	4.99	4.50
A09148-3014	14	1/2"	5/8"	4.99	4.50
A09148-3016	16	17/32"	5/8"	6.27	5.64
Series 73 Short Handle Angle Shader					
A09148-4018	1/8"	1/8"	7/32"	\$3.70	\$3.33
A09148-4038	3/8"	3/8"	1/2"	4.99	4.50
A09148-4014	1/4"	1/4"	13/32"	4.99	4.50
A09148-4012	1/2"	1/2"	5/8"	6.27	5.64
A09148-4058	5/8"	5/8"	13/16"	6.27	5.64
A09148-4034	3/4"	3/4"	15/16"	6.27	5.64
A09148-4001	1"	1"	1-1/16"	7.52	6.77
Series 73 Short Handle Chisel Blender					
A09148-6004	4	1/4"	9/32"	\$3.70	\$3.33
A09148-6006	6	5/16"	21/64"	4.99	4.50
A09148-6008	8	3/8"	3/8"	4.99	4.50
A09148-6010	10	13/32"	7/16"	4.99	4.50
Series 73 Short Handle Fan Blender					
A09148-5020	2/0	1-5/16"	1/2"	\$3.70	\$3.33
A09148-5002	2	1-5/8"	7/8"	3.70	3.33
A09148-5004	4	1-9/1			

BLICK® economy

brushes for the beginning student

- good quality
- seamless aluminum ferrules
- lacquered natural wood handles
- value priced



A-B Blick® Economy Ox/Pony Hair

A combination of 60% ox and 40% pony hair makes this brush exceptionally affordable and an excellent all-around brush for students exploring the use of thicker, heavier colors.

NUMBER	SIZE	DIA	LENGTH	EACH	24/EA	48/EA
A05149-1000	0	1/32"	5/16"	\$.70	\$.63	\$.60
A05149-1001	1	1/16"	3/8"	.77	.68	.65
A05149-1002	2	1/16"	7/16"	.81	.72	.69
A05149-1004	4	3/32"	19/32"	.91	.81	.78
A05149-1006	6	1/8"	23/32"	1.11	.99	.95
A05149-1008	8	5/32"	3/4"	1.42	1.27	1.21
A05149-1010	10	7/32"	27/32"	1.62	1.45	1.38
A05149-1012	12	9/32"	7/8"	1.93	1.73	1.64
A05149-1014	14	5/16"	1"	2.13	1.91	1.82

Round 9-Brush Set — Sizes: 0, 1, 2, 4, 6, 8, 10, 12, and 14.

NUMBER	EACH	6/EA	12/EA
A05149-0099	\$9.37	\$8.43	\$7.99

B Bright

NUMBER	SIZE	WIDTH	LENGTH	EACH	24/EA	48/EA
A05148-1000	0	1/32"	5/32"	\$.71	\$.63	\$.60
A05148-1001	1	1/16"	1/4"	.77	.68	.65
A05148-1002	2	3/32"	1/4"	.81	.72	.69
A05148-1004	4	5/32"	9/32"	.92	.81	.77
A05148-1006	6	3/16"	5/16"	1.03	.90	.86
A05148-1008	8	1/4"	3/8"	1.23	1.09	1.03
A05148-1010	10	5/16"	15/32"	1.43	1.27	1.21
A05148-1012	12	3/8"	9/16"	1.64	1.45	1.38
A05148-1014	14	15/32"	21/32"	1.94	1.73	1.64

Bright 9-Brush Set — Sizes: 0, 1, 2, 4, 6, 8, 10, 12, and 14.

NUMBER	EACH	6/EA	12/EA
A05148-0099	\$9.37	\$8.43	\$7.99

Brushes shown actual size, except brush sets.

C-F Blick® Economy Sable

Strength, spring ("snap"), and ability to retain its shape make sable a top painter's choice in virtually all media. Though priced for a student budget, our economy sable brush holds a point or edge well. The highly resilient, pure red sable hair is hand-cupped.

C Round

NUMBER	SIZE	DIA	LENGTH	EACH	24/EA	48/EA
A05166-1000	0	1/32"	5/16"	\$.87	\$.78	\$.74
A05166-1001	1	1/16"	11/32"	1.15	1.03	.98
A05166-1002	2	1/16"	7/16"	1.26	1.13	1.08
A05166-1004	4	3/32"	19/32"	1.61	1.44	1.37
A05166-1006	6	1/8"	5/8"	1.84	1.65	1.57
A05166-1008	8	5/32"	25/32"	2.19	1.96	1.87
A05166-1010	10	7/32"	13/16"	2.42	2.17	2.06
A05166-1012	12	9/32"	29/32"	2.77	2.48	2.36
A05166-1014	14	5/16"	1"	2.99	2.69	2.56

Round 4-Brush Set — Sizes: 0, 1, 2, and 4.

NUMBER	EACH	12/EA	24/EA
A05166-0049	\$2.79	\$2.51	\$2.38

D Flat

NUMBER	SIZE	WIDTH	LENGTH	EACH	24/EA	48/EA
A05165-1000	0	1/32"	7/32"	\$.64	\$.58	\$.55
A05165-1001	1	1/16"	1/4"	.74	.66	.63
A05165-1002	2	3/32"	9/32"	.83	.75	.71
A05165-1004	4	5/32"	11/32"	1.03	.92	.87
A05165-1006	6	3/16"	15/32"	1.20	1.08	1.03
A05165-1008	8	1/4"	17/32"	1.39	1.25	1.19
A05165-1010	10	5/16"	21/32"	1.95	1.76	1.66
A05165-1012	12	3/8"	23/32"	2.42	2.18	2.06
A05165-1014	14	15/32"	13/16"	2.70	2.43	2.30

Flat 4-Brush Set — Sizes: 0, 1, 2, and 4.

NUMBER	EACH	12/EA	24/EA
A05165-0049	\$2.79	\$2.51	\$2.38

Brushes shown actual size, except brush sets.

E Filbert

NUMBER	SIZE	WIDTH	LENGTH	EACH	24/EA	48/EA
A05164-1000	0	1/32"	7/32"	\$.82	\$.74	\$.70
A05164-1001	1	1/16"	9/32"	.91	.82	.78
A05164-1002	2	3/32"	11/32"	1.00	.90	.85
A05164-1004	4	5/32"	15/32"	1.19	1.07	.99
A05164-1006	6	3/16"	1/2"	1.28	1.15	1.09
A05164-1008	8	1/4"	9/16"	1.46	1.32	1.25
A05164-1010	10	5/16"	21/32"	1.74	1.56	1.48
A05164-1012	12	3/8"	3/4"	2.29	2.06	1.95
A05164-1014	14	15/32"	13/16"	2.57	2.31	2.18

Filbert 4-Brush Set — Sizes: 0, 1, 2, and 4.

NUMBER	EACH	12/EA	24/EA
A05164-0049	\$3.61	\$3.24	\$3.08

F Bright

NUMBER	SIZE	WIDTH	LENGTH	EACH	24/EA	48/EA
A05163-1000	0	1/32"	3/16"	\$.93	\$.83	\$.79
A05163-1001	1	1/16"	3/16"	1.03	.93	.88
A05163-1002	2	3/32"	7/32"	1.14	1.03	.97
A05163-1004	4	5/32"	9/32"	1.34	1.21	1.15
A05163-1006	6	3/16"	11/32"	1.45	1.30	1.24
A05163-1008	8	1/4"	13/32"	1.66	1.49	1.42
A05163-1010	10	5/16"	15/32"	1.97	1.77	1.68
A05163-1012	12	3/8"	17/32"	2.18	1.96	1.86
A05163-1014	14	15/32"	5/8"	2.49	2.24	2.13



Bright 4-Brush Set — Sizes: 0, 1, 2, and 4.

NUMBER	EACH	12/EA	24/EA
A05163-0049	\$2.85	\$2.56	\$2.43



G-J Blick® Economy White Bristle

Extra-long white hog bristle fills these good-quality brushes. Especially useful for beginning oil and acrylic painting because they are thick enough to push heavy paint around with ease.

G Round

NUMBER	SIZE	DIA	LENGTH	EACH	24/EA	48/EA
A05162-1000	0	1/32"	11/32"	\$1.20	\$1.08	\$1.03
A05162-1001	1	1/16"	1/2"	1.42	1.28	1.22
A05162-1002	2	1/16"	9/16"	1.64	1.48	1.40
A05162-1004	4	3/32"	5/8"	1.86	1.68	1.59
A05162-1006	6	1/8"	23/32"	2.08	1.87	1.78
A05162-1008	8	5/32"	13/16"	2.30	2.07	1.97
A05162-1010	10	7/32"	7/8"	2.63	2.37	2.25
A05162-1012	12	9/32"	1-1/32"	2.85	2.57	2.44
A05162-1014	14	5/16"	1-1/8"	3.07	2.77	2.63
A05162-1016	16	3/8"	1-1/4"	3.29	2.96	2.82
A05162-1024	24	11/16"	1-11/16"	3.95	3.56	3.38

Round 6-Brush Set — Sizes: 0, 1, 2, 4, 6, and 8.

NUMBER	EACH	6/EA	12/EA
A05162-0069	\$7.91	\$7.13	\$6.77

H Flat

NUMBER	SIZE	WIDTH	LENGTH	EACH	24/EA	48/EA
A05169-1000	0	1/32"	11/32"	\$.80	\$.72	\$.68
A05169-1001	1	1/16"	3/8"	.91	.82	.78
A05169-1002	2	3/32"	15/32"	1.03	.92	.87
A05169-1004	4	5/32"	17/32"	1.33	1.19	1.13
A05169-1006	6	3/16"	19/32"	1.49	1.34	1.27
A05169-1008	8	1/4"	21/32"	1.72	1.54	1.46
A05169-1010	10	5/16"	11/16"	1.95	1.75	1.66
A05169-1012	12	3/8"	27/32"	2.42	2.17	2.05
A05169-1014	14	15/32"	7/8"	2.53	2.27	2.15
A05169-1016	16	9/16"	1"	2.76	2.48	2.35
A05169-1024	24	31/32"	1-3/16"	3.34	2.99	2.84

Flat 6-Brush Set

NUMBER	EACH	6/EA	12/EA
A05169-0069	\$5.99	\$5.38	\$5.10

Blick® Economy White Bristle — Set of 6

Assorted Set includes size 8 and 14 Rounds, size 6 and 14 Flats, size 8 Bright, and size 8 Filbert.

NUMBER	EACH	12/EA	24/EA
A05175-0069	\$11.73	\$10.55	\$10.03

I Filbert

NUMBER	SIZE	WIDTH	LENGTH	EACH	24/EA	48/EA
A05161-1000	0	1/32"	11/32"	\$.63	\$.57	\$.54
A05161-1001	1	1/16"	3/8"	.86	.77	.73
A05161-1002	2	3/32"	15/32"	1.03	.92	.87
A05161-1004	4	5/32"	9/16"	1.25	1.12	1.06
A05161-1006	6	3/16"	19/32"	1.48	1.33	1.26
A05161-1008	8	1/4"	5/8"	1.89	1.70	1.61
A05161-1010	10	5/16"	23/32"	2.16	1.95	1.84
A05161-1012	12	3/8"	13/16"	2.51	2.26	2.14
A05161-1014	14	15/32"	29/32"	2.62	2.36	2.24
A05161-1016	16	9/16"	1"	2.97	2.67	2.53
A05161-1024	24	31/32"	1-5/16"	3.54	3.18	3.03

Filbert 6-Brush Set — Sizes: 0, 1, 2, 4, 6, and 8.

NUMBER	EACH	6/EA	12/EA
A05161-0069	\$6.24	\$5.61	\$5.33

J Bright

NUMBER	SIZE	WIDTH	LENGTH	EACH	24/EA	48/EA
A05170-1000	0	1/32"	5/16"	\$.76	\$.68	\$.65
A05170-1001	1	1/16"	3/8"	.94	.84	.80
A05170-1002	2	3/32"	7/16"	1.15	1.03	.98
A05170-1004	4	5/32"	1/2"	1.36	1.22	1.16
A05170-1006	6	3/16"	9/16"	1.57	1.41	1.34
A05170-1008	8	1/4"	5/8"	1.78	1.60	1.52
A05170-1010	10	5/16"	21/32"	1.89	1.69	1.61
A05170-1012	12	3/8"	3/4"	1.99	1.79	1.70
A05170-1014	14	15/32"	25/32"	2.20	1.98	1.88
A05170-1016	16	9/16"	25/32"	2.52	2.26	2.15
A05170-1024	24	31/32"	31/32"	3.04	2.74	2.60

Bright 6-Brush Set

NUMBER	EACH	6/EA	12/EA
A05170-0069	\$6.33	\$5.69	\$5.41

Class Pack of 72 Brights — Eight each of sizes 0, 1, 2, 4, 6, 8, 10, 12, and 14.

NUMBER	EACH	6/EA	12/EA
A05170-0729	\$86.53	\$77.88	\$73.99

K Blick® Economy Black Bristle Easel

A hard-wearing, multi-purpose brush in economical 100% natural black bristle, great for oils, acrylics, or tempera.

NUMBER	SIZE	LENGTH	EACH	12/EA	24/EA
A05172-4014	1/4"	23/32"	\$.87	\$.78	\$.74
A05172-4012	1/2"	1"	1.07	.95	.90
A05172-4034	3/4"	1-7/32"	1.56	1.39	1.32
A05172-1001	1"	1-7/16"	1.85	1.65	1.57

Class Pack of 24 Black Bristle Easels — Includes six brushes each of sizes 1/4", 1/2", 3/4", and 1".

NUMBER	EACH	6/EA	12/EA
A05172-0249	\$28.37	\$25.53	\$24.26



Blick® Economy Black Bristle Set

This hard-wearing, multi-purpose, long-handled brush set of black bristle is very useful for the classroom. The four-brush set includes four Flat Easel brushes (Size 1/2",

BLICK® economy

brushes for the beginning student

Brushes shown actual size, except brush sets.



A-C Blick® Economy Golden Taklon

Taklon is a type of synthetic filament that is dyed and baked to make it softer and more absorbent. Exceptionally easy to clean, this economical grade of golden taklon is a great choice for oils and acrylics because it withstands the caustic nature of solvents and acrylic paints better than animal hair for greater durability overall.

A Round

NUMBER	SIZE	DIA	LENGTH	EACH	12/EA	24/EA
A05151-1000	0	1/32"	11/32"	\$2.78	\$2.49	\$2.37
A05151-1001	1	1/16"	3/8"	2.99	2.70	2.57
A05151-1002	2	1/16"	15/32"	3.36	2.99	2.86
A05151-1004	4	3/32"	5/8"	3.82	3.43	3.26
A05151-1006	6	1/8"	3/4"	4.17	3.74	3.56
A05151-1008	8	5/32"	7/8"	4.52	4.06	3.86
A05151-1010	10	7/32"	31/32"	4.75	4.26	4.05
A05151-1012	12	9/32"	1-3/16"	6.96	6.24	5.94
A05151-1014	14	5/16"	1-5/16"	9.63	8.64	8.22

B Flat

NUMBER	SIZE	WIDTH	LENGTH	EACH	12/EA	24/EA
A05168-1000	0	1/32"	5/32"	\$2.64	\$2.38	\$2.25
A05168-1001	1	1/16"	7/32"	2.75	2.47	2.35
A05168-1002	2	3/32"	1/4"	3.07	2.76	2.62
A05168-1004	4	5/32"	11/32"	3.28	2.95	2.80
A05168-1006	6	3/16"	15/32"	3.60	3.24	3.07
A05168-1008	8	1/4"	19/32"	3.81	3.43	3.25
A05168-1010	10	5/16"	3/4"	4.45	3.99	3.79
A05168-1012	12	3/8"	3/4"	5.30	4.77	4.52
A05168-1014	14	15/32"	7/8"	6.14	5.53	5.24

C Bright

NUMBER	SIZE	WIDTH	LENGTH	EACH	12/EA	24/EA
A05150-1000	0	1/32"	3/32"	\$2.58	\$2.32	\$2.21
A05150-1001	1	1/16"	1/8"	2.80	2.51	2.39
A05150-1002	2	3/32"	5/32"	3.12	2.80	2.67
A05150-1004	4	5/32"	1/4"	3.34	2.99	2.85
A05150-1006	6	3/16"	5/16"	3.44	3.10	2.94
A05150-1008	8	1/4"	3/8"	3.66	3.29	3.13
A05150-1010	10	5/16"	7/16"	4.20	3.78	3.59
A05150-1012	12	3/8"	9/16"	5.60	5.04	4.79
A05150-1014	14	15/32"	5/8"	6.79	6.10	5.81

Blick® Economy Golden Nylon Round Class Pack of 72

Includes eight of each size 0 through 14 Round.

NUMBER	EACH	6/EA	12/EA
A05159-0729	\$305.00	\$274.35	

D-F Blick® Economy Golden Nylon

Synthetics are a perfect match for oil and acrylic paints in a classroom setting because they're easier to clean than natural hair brushes, are more durable, and can withstand harsh acrylic paints with less damage. This synthetic brush is a logical choice that can handle everything from detail painting to bold, sweeping strokes.

D Round

NUMBER	SIZE	DIA	LENGTH	EACH	12/EA	24/EA
A05159-1000	0	1/32"	9/32"	\$2.61	\$2.35	\$2.23
A05159-1001	1	1/16"	3/8"	3.07	2.77	2.62
A05159-1002	2	1/16"	13/32"	3.99	3.60	3.41
A05159-1004	4	3/32"	17/32"	4.23	3.81	3.61
A05159-1006	6	1/8"	5/8"	4.38	3.94	3.74
A05159-1008	8	5/32"	29/32"	5.38	4.84	4.60
A05159-1010	10	7/32"	1-1/32"	6.38	5.75	5.45
A05159-1012	12	9/32"	1-5/32"	6.92	6.23	5.91
A05159-1014	14	5/16"	1-11/32"	7.54	6.79	6.44
A05159-1016	16	3/8"	1-1/2"	8.31	7.48	7.10
A05159-1018	18	15/32"	1-9/16"	9.08	8.17	7.76
A05159-1020	20	9/16"	1-11/16"	9.85	8.87	8.41

E Flat

NUMBER	SIZE	WIDTH	LENGTH	EACH	12/EA	24/EA
A05158-4014	1/4"	1/4"	23/32"	\$2.48	\$2.24	\$2.13
A05158-4012	1/2"	1/2"	1"	3.11	2.80	2.66
A05158-4034	3/4"	3/4"	1-1/8"	4.51	4.06	3.86
A05158-1001	1"	1"	1-3/8"	6.07	5.46	5.19

F Bright

NUMBER	SIZE	WIDTH	LENGTH	EACH	12/EA	24/EA
A05157-1000	0	1/32"	1/8"	\$2.04	\$1.83	\$1.74
A05157-1001	1	1/16"	1/8"	2.38	2.14	2.04
A05157-1002	2	3/32"	3/16"	2.52	2.26	2.15
A05157-1004	4	5/32"	5/16"	2.86	2.57	2.44
A05157-1006	6	3/16"	11/32"	3.07	2.75	2.62
A05157-1008	8	1/4"	3/8"	3.41	3.06	2.91
A05157-1010	10	5/16"	17/32"	3.96	3.55	3.38
A05157-1012	12	3/8"	3/4"	4.64	4.16	3.96
A05157-1014	14	15/32"	27/32"	5.32	4.78	4.54
A05157-1016	16	9/16"	29/32"	5.99	5.39	5.13
A05157-1018	18	11/16"	1"	6.69	5.99	5.71
A05157-1020	20	13/16"	1-1/8"	7.17	6.43	6.12

Blick® Economy Golden Nylon Bright Class Pack of 72

Includes eight of each size 0 through 14 Bright.

NUMBER	EACH	6/EA	12/EA
A05157-0729	\$364.00	\$328.00	

Blick® Economy Golden Taklon Round 6-Brush Set

Sizes: 0, 1, 2, 4, 6, and 8.

NUMBER	EACH	6/EA	12/EA
A05151-0069	\$16.24	\$14.59	\$13.86

Blick® Economy Golden Taklon Flat 6-Brush Set

Sizes: 0, 1, 2, 4, 6, and 8.

NUMBER	EACH	6/EA	12/EA
A05168-0059	\$16.29	\$14.66	\$13.93

Blick® Economy Golden Taklon Bright 6-Brush Set

Sizes: 0, 1, 2, 4, 6, and 8.

NUMBER	EACH	6/EA	12/EA
A05150-0069	\$15.23	\$13.70	\$12.99

Blick® Economy Golden Nylon Round 6-Brush Set

Sizes: 0, 1, 2, 4, 6, and 8.

NUMBER	EACH	6/EA	12/EA
A05159-0069	\$19.62	\$17.66	\$16.78

Blick® Economy Golden Nylon Flat 4-Brush Set

Sizes: 1/4", 1/2", 3/4", and 1".

NUMBER	EACH	6/EA	12/EA
A05158-0049	\$12.88	\$11.59	\$10.99

Blick® Economy Golden Nylon Bright 6-Brush Set

Sizes: 0, 1, 2, 4, 6, and 8.

NUMBER	EACH	6/EA	12/EA
A05157-0069	\$16.29	\$14.66	\$13.93

Blick® Economy Golden Nylon Assorted 6-Brush Set

Sizes: Sizes 4 and 8 Round, Sizes 6 and 12 Bright, and Sizes 1/4" and 1/2" Flat.

NUMBER	EACH	6/EA	12/EA
A05173-0069	\$19.75	\$17.78	\$16.89

BLICK® scholastic

brushes for the intermediate student

- better quality
- seamless nickel-plated brass ferrules
- lacquered natural wood handles

Blick® Scholastic Red Sable Round 5-Brush Set

Sizes: 0, 1, 2, 4, and 6.

NUMBER	EACH	12/EA	24/EA
A05948-0059	\$11.63	\$10.46	\$9.93

Blick® Scholastic Red Sable Flat 5-Brush Set

Sizes: 0, 1, 2, 4, and 6.

NUMBER	EACH	12/EA	24/EA
A05947-0059	\$11.63	\$10.46	\$9.93

Blick® Scholastic Red Sable Bright 3-Brush Set

Sizes: 4, 6, and 8.

NUMBER	EACH	12/EA	24/EA
A05944-0039	\$7.05	\$6.35	\$6.03

Blick® Scholastic Red Sable Bright 5-Brush Set

Sizes: 0, 1, 2, 4, and 6.

NUMBER	EACH	12/EA	24/EA
A05944-0059	\$11.63	\$10.46	\$9.93

Blick® Scholastic Red Sable Filbert 5-Brush Set

Sizes: 0, 1, 2, 4, and 6.

NUMBER	EACH	12/EA	24/EA
A05946-0059	\$11.63	\$10.46	\$9.93

Blick® Scholastic Red Sable Fan 3-Brush Set

Sizes: 2, 4, and 6.

NUMBER	EACH	12/EA	24/EA
A05945-0039	\$9.08	\$8.17	\$7.76



G-H Blick® Scholastic Ox Hair

An excellent all-around workhorse for students painting with thicker, heavier colors. Dependable craftsmanship gives this brush nice balance; the hairs offer good resiliency and snap with a varied selection of Rounds and Brights.

G Round

NUMBER	SIZE	DIA	LENGTH	EACH	12/EA	24/EA
A05943-7030	3/0	1/64"	1/4"	\$1.88	\$1.69	\$1.60
A05943-7020	2/0	1/32"	1/4"	2.16	1.94	1.84
A05943-1000	0	1/32"	9/32"	2.35	2.11	1.99
A05943-1001	1	1/16"	3/8"	2.63	2.37	2.25
A05943-1002	2	1/16"	15/32"	2.82	2.54	2.41
A05943-1004	4	3/32"	11/16"	3.10	2.79	2.65
A05943-1006	6	1/8"	25/32"	3.29	2.96	2.81
A05943-1008	8	5/32"	29/32"	3.57	3.21	3.05
A05943-1010	10	7/32"	1-1/32"	4.23	3.81	3.62
A05943-1012	12	9/32"	1-3/16"	5.18	4.66	4.42
A05943-1014	14	5/16"	1-3/8"	6.40	5.76	5.47
A05943-1016	16	3/8"	1-1/2"	7.34	6.60	6.27

H Bright

NUMBER	SIZE	WIDTH	LENGTH	EACH	12/EA	24/EA
A05942-1000	0	1/32"	1/8"	\$1.99	\$1.79	\$1.70
A05942-1001	1	1/16"	5/32"	2.17	1.95	1.85
A05942-1002	2	3/32"	3/16"	2.43	2.19	2.08
A05942-1004	4	5/32"	9/32"	2.60	2.34	2.22
A05942-1006	6	3/16"	11/32"	2.86	2.58	2.45
A05942-1008	8	1/4"	13/32"	3.30	2.97	2.82
A05942-1010	10	5/16"	15/32"	3.74	3.36	3.19
A05942-1012	12	3/8"	9/16"	4.34	3.91	3.71
A05942-1014	14	15/32"	5/8"	5.04	4.54	4.31
A05942-1016	16	9/16"	11/16"	5.65	5.09	4.83

Blick® Scholastic Ox Hair Bright 6-Brush Set

Sizes: 0, 1, 2, 4, 6, and 8.

NUMBER	EACH	6/EA	12/EA
A05942-0059	\$11.09	\$9.98	\$9.49

Blick® Scholastic Ox Hair Round 6-Brush Set

Sizes: 0, 1, 2, 4, 6, and 8.

NUMBER	EACH	6/EA	12/EA
A05943-0059	\$14.13	\$12.71	\$12.07

I-M Blick® Scholastic Red Sable

Excellent quality and traditional craftsmanship make our Scholastic Red Sable a value that beginning or professional artists will appreciate. Offering snap and resiliency, they handle oil or acrylic beautifully.

I Round

NUMBER	SIZE	DIA	LENGTH	EACH	12/EA	24/EA
A05948-7030	3/0	1/64"	1/4"	\$2.36	\$2.12	\$1.99
A05948-7020	2/0	1/32"	17/64"	2.45	2.20	2.09
A05948-1000	0	1/32"	5/16"	2.54	2.29	2.17
A05948-1001	1	1/16"	3/8"	2.64	2.37	2.25
A05948-1002	2	1/16"	15/32"	2.83	2.54	2.42
A05948-1004	4	3/32"	11/16"	3.30	2.97	2.82
A05948-1006	6	1/8"	3/4"	4.06	3.65	3.47
A05948-1008	8	5/32"	15/16"	5.66	5.10	4.84
A05948-1010	10	7/32"	1"	7.08	6.37	6.05
A05948-1012	12	9/32"	1-3/16"	11.81	10.63	10.09
A05948-1014	14	5/16"	1-3/8"	16.07	14.46	13.73
A05948-1016	16	3/8"	1-1/2"	21.27	19.14	18.17

BLICK® scholastic

brushes for the intermediate student

Brushes shown actual size, except brush sets.



A-E Blick® Scholastic White Bristle **LONGhandle**

Students will love the excellent feel and results these brushes deliver. The hair is 100% hog bristle — an economical, yet high-performance hair, ideal for spreading medium to thick paints smoothly and evenly.

A Round

NUMBER	SIZE	DIA	LENGTH	EACH	12/EA	24/EA
A05953-1000	0	1/32"	5/16"	\$2.92	\$2.63	\$2.50
A05953-1001	1	1/16"	3/8"	3.37	3.03	2.88
A05953-1002	2	1/16"	13/32"	3.81	3.43	3.26
A05953-1004	4	3/32"	9/16"	4.26	3.83	3.64
A05953-1006	6	1/8"	21/32"	4.88	4.39	4.17
A05953-1008	8	5/32"	23/32"	5.59	5.03	4.78
A05953-1010	10	7/32"	7/8"	6.04	5.43	5.16
A05953-1012	12	9/32"	1-1/8"	6.48	5.83	5.54
A05953-1014	14	5/16"	1-1/4"	7.10	6.39	6.07
A05953-1016	16	3/8"	1-13/32"	7.82	7.03	6.68
A05953-1018	18	15/32"	1-11/16"	8.26	7.43	7.06

C Filbert

NUMBER	SIZE	WIDTH	LENGTH	EACH	12/EA	24/EA
A05952-1000	0	1/32"	9/32"	\$3.48	\$3.13	\$2.97
A05952-1001	1	1/16"	11/32"	3.66	3.29	3.13
A05952-1002	2	3/32"	3/8"	3.94	3.54	3.36
A05952-1004	4	5/32"	7/16"	4.58	4.12	3.91
A05952-1006	6	3/16"	15/32"	5.04	4.53	4.30
A05952-1008	8	1/4"	5/8"	5.31	4.78	4.54
A05952-1010	10	5/16"	3/4"	5.77	5.19	4.93
A05952-1012	12	3/8"	15/16"	6.41	5.77	5.48
A05952-1014	14	15/32"	1-1/16"	7.15	6.43	6.11
A05952-1016	16	9/16"	1-1/16"	8.25	7.42	7.05
A05952-1018	18	11/16"	1-5/16"	9.90	8.90	8.46

D Bright

NUMBER	SIZE	WIDTH	LENGTH	EACH	12/EA	24/EA
A05950-1000	0	1/32"	1/8"	\$3.40	\$3.06	\$2.90
A05950-1001	1	1/16"	5/32"	3.58	3.22	3.06
A05950-1002	2	3/32"	3/16"	3.85	3.46	3.29
A05950-1004	4	5/32"	1/4"	4.48	4.03	3.82
A05950-1006	6	3/16"	3/8"	4.93	4.43	4.21
A05950-1008	8	1/4"	3/8"	5.20	4.68	4.44
A05950-1010	10	5/16"	9/16"	5.65	5.08	4.82
A05950-1012	12	3/8"	23/32"	6.28	5.64	5.36
A05950-1014	14	15/32"	13/16"	6.99	6.29	5.97
A05950-1016	16	9/16"	27/32"	8.07	7.26	6.89
A05950-1018	18	11/16"	15/16"	9.69	8.71	8.27

E Fan

NUMBER	SIZE	WIDTH	LENGTH	EACH	12/EA	24/EA
A05951-1002	2	1-1/4"	7/8"	\$4.59	\$4.13	\$3.92
A05951-1004	4	1-1/2"	1-3/32"	5.05	4.54	4.31
A05951-1006	6	1-3/4"	1-11/32"	5.97	5.37	5.10

Blick® Scholastic White Bristle **6-Brush Set**

Sizes: 8 and 12 Flat; 6 and 10 Round; and 12 and 18 Bright.

NUMBER	EACH	6/EA	12/EA
A05955-0069	\$31.80	\$28.62	\$27.19

Blick® Scholastic White Bristle **Round 6-Brush Set**

Sizes: 0, 1, 2, 4, 6, and 8.

NUMBER	EACH	6/EA	12/EA
A05953-0069	\$18.82	\$16.92	\$16.09

Blick® Scholastic White Bristle **Flat 6-Brush Set**

Sizes: 0, 1, 2, 4, 6, and 8.

NUMBER	EACH	6/EA	12/EA
A05949-0069	\$18.82	\$16.92	\$16.09

Blick® Scholastic White Bristle **Filbert 6-Brush Set**

Sizes: 0, 1, 2, 4, 6, and 8.

NUMBER	EACH	6/EA	12/EA
A05952-0069	\$18.82	\$16.92	\$16.09

Blick® Scholastic White Bristle **Bright 6-Brush Set**

Sizes: 0, 1, 2, 4, 6, and 8.

NUMBER	EACH	6/EA	12/EA
A05950-0069	\$18.82	\$16.92	\$16.09

Blick® Scholastic White Bristle **Fan 3-Brush Set**

Sizes: 2, 4, and 6.

NUMBER	EACH	6/EA	12/EA
A05951-0039	\$11.03	\$9.92	\$9.42

BLICK® scholastic

brushes for the intermediate student



Blick® Scholastic Golden Taklon **Round 6-Brush Set**

Sizes: 0, 1, 2, 4, 6, and 8.

NUMBER	EACH	6/EA	12/EA
A05385-0069	\$14.53	\$13.08	\$12.43

Blick® Scholastic Golden Taklon **Flat 6-Brush Set**

Sizes: 0, 1, 2, 4, 6, and 8.

NUMBER	EACH	6/EA	12/EA
A05384-0069	\$13.48	\$12.13	\$11.53

Blick® Scholastic Golden Taklon **Bright 6-Brush Set**

Sizes: 0, 1, 2, 4, 6, and 8.

NUMBER	EACH	6/EA	12/EA
A05382-0069	\$13.48	\$12.13	\$11.53

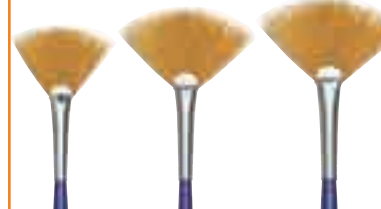

Blick® Scholastic Golden Taklon **Fan 3-Brush Set**

Sizes: 2, 4, and 6.

NUMBER	EACH	6/EA	12/EA
A05383-0039	\$12.45	\$11.20	\$10.65



F-I Blick® Scholastic Golden Taklon **LONGhandle**

Easy to clean and exceptionally durable, this better grade of golden taklon is an excellent choice for oils and acrylics because it stands up to solvents and acrylic paints very well. Soft and absorbent with plenty of "snap."

F Round

NUMBER	SIZE	DIA	LENGTH	EACH	12/EA	24/EA
A05385-7040	4/0	1/64"	5/32"	\$2.16	\$1.94	\$1.84
A05385-7030	3/0	1/64"	7/32"	2.25	2.03	1.92
A05385-7020	2/0	1/32"	1/4"	2.35	2.11	1.99
A05385-1000	0	1/32"	9/32"	2.44	2.20	2.08
A05385-1001	1	1/16"	3/8"	2.63	2.37	2.25
A05385-1002	2	1/16"	15/32"	2.82	2.54	2.41
A05385-1004	4	3/32"	11/16"	3.29	2.96	2.81
A05385-1006	6	1/8"	3/4"	3.57	3.21	3.05
A05385-1008	8	5/32"	29/32"	3.76	3.38	3.21
A05385-1010	10	7/32"	1"	4.52	4.06	3.86
A05385-1012	12	9/32"	1-3/16"	6.59	5.93	5.63
A05385-1014	14	5/16"	1-3/8"	7.99	7.20	6.84
A05385-1016	16	3/8"	1-7/16"	9.70	8.73	8.29

I Bright

NUMBER	SIZE	WIDTH	LENGTH	EACH	12/EA	24/EA
A05382-1000	0	1/32"	1/8"	\$2.21	\$1.98	\$1.88
A05382-1001	1	1/16"	5/32"	2.41	2.16	2.05
A05382-1002	2	3/32"	3/16"	2.70	2.42	2.30
A05382-1004	4	5/32"	9/32"	2.89	2.59	2.46
A05382-1006	6	3/16"	11/32"	3.18	2.85	2.71
A05382-1008	8	1/4"	13/32"	3.66	3.28	3.12
A05382-1010	10	5/16"	1/2"	3.86	3.46	3.28
A05382-1012	12	3/8"	19/32"	4.63	4.15	3.94
A05382-1014	14	15/32"	5/8"	5.31	4.76	4.52
A05382-1016	16	9/16"	11/16"	5.79	5.19	4.93

G Flat

NUMBER	SIZE	WIDTH	LENGTH	EACH	12/EA	24/EA
A05384-1000	0	1/32"	3/16"	\$2.15	\$1.94	\$1.84
A05384-1001	1	1/16"	7/32"	2.53	2.27	2.16
A05384-1002	2	3/32"	9/32"	2.81	2.53	2.40
A05384-1004	4	5/32"	11/32"	3.09	2.78	2.64
A05384-1006	6	3/16"	15/32"	3.28	2.95	2.80
A05384-1008	8	1/4"	9/16"	3.75	3.37	3.20
A05384-1010	10	5/16"	3/4"	4.22	3.79	3.60
A05384-1012	12	3/8"	25/32"	5.16	4.64	4.40
A05384-1014	14	15/32"	29/32"	5.63	5.06	4.81
A05384-1016	16	9/16"	31/32"	5.91	5.32	5.05

H Fan

NUMBER	SIZE	WIDTH	LENGTH	EACH	12/EA	24/EA
A05383-1002	2	1-9/32"	15/16"	\$5.20	\$4.68	\$4.45
A05383-1004	4	1-19/32"	1-1/32"	5.39	4.85	4.61
A05383-1006	6	1-9/16"	1-3/32"	5.69	5.13	4.87

LONGhandle



Blick® Scholastic Sable & Taklon Set

This set of six brushes offers a mixture of natural and synthetic hair, supplying softness and strength. It includes Red Sable Brights in Sizes 2 and 10, Red Sable Rounds in Sizes 2/0 and 8, plus a Golden Taklon Round Size 4, and Flat Size 6.

NUMBER	EACH	6/EA	12/EA
A05956-0069	\$17.47	\$15.73	\$14.93

Brushes shown actual size, except brush sets.

BLICK® scholastic

brushes for the intermediate student

Brushes shown actual size, except brush sets.



A-F Blick® Scholastic Wonder White **LONG**handle

Blick's white taklon delivers the texture and responsiveness of red sable, yet holds up to the caustic nature of solvents and acrylic paints with greater durability, making these brushes a must-have for the classroom. The sharp point has good spring; the selection of shapes and sizes means there's a Wonder White brush for every medium and application.

A Round				D Filbert			
NUMBER	SIZE	DIA	LENGTH	NUMBER	SIZE	WIDTH	LENGTH
A05381-7030	3/0	1/64"	1/4"	A05379-1000	0	1/32"	5/32"
A05381-7020	2/0	1/32"	9/32"	A05379-1001	1	1/16"	3/16"
A05381-1000	0	1/32"	5/16"	A05379-1002	2	3/32"	1/4"
A05381-1001	1	1/16"	3/8"	A05379-1004	4	5/32"	5/16"
A05381-1002	2	1/16"	1/2"	A05379-1006	6	3/16"	13/32"
A05381-1004	4	3/32"	11/16"	A05379-1008	8	1/4"	1/2"
A05381-1006	6	1/8"	3/4"	A05379-1010	10	5/16"	17/32"
A05381-1008	8	5/32"	29/32"	A05379-1012	12	3/8"	23/32"
A05381-1010	10	7/32"	31/32"	A05379-1014	14	15/32"	13/16"
A05381-1012	12	9/32"	1-3/16"	A05379-1016	16	9/16"	7/8"
A05381-1014	14	5/16"	1-3/8"				
A05381-1016	16	3/8"	1-7/16"				
A05381-1020	20	9/16"	1-3/4"				
A05381-1024	24	11/16"	2"				

B Flat			
NUMBER	SIZE	WIDTH	LENGTH
A05380-1000	0	1/32"	3/16"
A05380-1001	1	1/16"	7/32"
A05380-1002	2	3/32"	9/32"
A05380-1004	4	5/32"	11/32"
A05380-1006	6	3/16"	15/32"
A05380-1008	8	1/4"	5/8"
A05380-1010	10	5/16"	3/4"
A05380-1012	12	3/8"	25/32"
A05380-1014	14	15/32"	29/32"
A05380-1016	16	9/16"	15/16"
A05380-1020	20	13/16"	1-1/8"
A05380-1024	24	31/32"	1-9/32"

C Script			
NUMBER	SIZE	DIA	LENGTH
A05565-7040	4/0	1/64"	13/32"
A05565-7020	2/0	1/32"	7/16"
A05565-1000	0	1/32"	9/16"
A05565-1001	1	1/16"	5/8"
A05565-1002	2	1/16"	23/32"
A05565-1004	4	3/32"	27/32"

E Bright			
NUMBER	SIZE	WIDTH	LENGTH
A05377-1000	0	1/32"	1/8"
A05377-1001	1	1/16"	3/16"
A05377-1002	2	3/32"	11/64"
A05377-1004	4	5/32"	9/32"
A05377-1006	6	3/16"	11/32"
A05377-1008	8	1/4"	13/32"
A05377-1010	10	5/16"	1/2"
A05377-1012	12	3/8"	5/8"
A05377-1014	14	15/32"	5/8"
A05377-1016	16	9/16"	11/16"
A05377-1020	20	13/16"	7/8"
A05377-1024	24	31/32"	1-1/32"

F Fan			
NUMBER	SIZE	WIDTH	LENGTH
A05378-1002	2	1-1/2"	15/16"
A05378-1004	4	1-3/4"	1-1/16"
A05378-1006	6	1-7/8"	1-3/16"

Blick® Scholastic Wonder White Assorted 6-Brush Set			
NUMBER	SIZE	EACH	12/EA
A05871-0069		\$25.03	\$22.52 \$21.39

- better quality
- seamless nickel-plated brass ferrules
- lacquered natural wood handles

Blick® Scholastic Wonder White Round 6-Brush Set

Sizes: 0, 1, 2, 4, 6, and 8.

NUMBER	EACH	6/EA	12/EA
A05381-0069	\$16.35	\$14.71	\$13.98

Blick® Scholastic Wonder White Flat 6-Brush Set

Sizes: 0, 1, 2, 4, 6, 8.

NUMBER	EACH	6/EA	12/EA
A05380-0069	\$18.17	\$16.35	\$15.53

Blick® Scholastic Wonder White Filbert 6-Brush Set

Sizes: 0, 1, 2, 4, 6, and 8.

NUMBER	EACH	6/EA	12/EA
A05379-0068	\$17.39	\$15.65	\$14.87

Blick® Scholastic Wonder White Bright 6-Brush Set

Sizes: 0, 1, 2, 4, 6, and 8.

NUMBER	EACH	6/EA	12/EA
A05377-0069	\$17.39	\$15.65	\$14.87

Blick® Scholastic Wonder White Fan 3-Brush Set

Sizes: 2, 4, and 6.

NUMBER	EACH	6/EA	12/EA
A05378-0039	\$15.35	\$13.82	\$13.12

BLICK® academic

brushes for the advanced student

- quality craftsmanship
- seamless nickel-plated brass ferrules
- lacquered natural wood handles



G-J Blick® Academic Bristle **LONG**handle

Top-grade natural bristle is bleached for a whiter appearance. Hairs have natural flagged tips and are never trimmed to shape. Long handle. The right choice for value and great performance.

G Round			
NUMBER	SIZE	DIA	LENGTH
A05919-1000	0	1/32"	5/16"
A05919-1002	2	1/16"	17/32"
A05919-1004	4	3/32"	11/16"
A05919-1006	6	1/8"	3/4"
A05919-1008	8	5/32"	15/16"
A05919-1012	12	9/32"	1-5/32"
A05919-1016	16	3/8"	1-13/32"
A05919-1020	20	9/16"	1-13/16"

6-Brush Set — Sizes: 2, 4, 6, 8, 12, and 16.			
NUMBER	EACH	6/EA	12/EA
A05919-0069	\$44.32	\$39.88	

H Flat			
NUMBER	SIZE	WIDTH	LENGTH
A05920-1000	0	1/32"	3/16"
A05920-1002	2	3/32"	9/32"
A05920-1004	4	5/32"	3/8"
A05920-1006	6	3/16"	1/2"
A05920-1008	8	1/4"	5/8"
A05920-1012	12	3/8"	13/16"
A05920-1016	16	9/16"	1-1/16"
A05920-1020	20	13/16"	1-5/16"

6-Brush Set — Sizes: 2, 4, 6, 8, 12, and 16.			
NUMBER	EACH	6/EA	12/EA
A05920-0069	\$37.99	\$34.19	

I Filbert			
NUMBER	SIZE	WIDTH	LENGTH
A05979-1000	0	1/32"	7/32"
A05979-1002	2	3/32"	1/4"
A05979-1004	4	5/32"	11/32"
A05979-1006	6	3/16"	7/16"
A05979-1008	8	1/4"	21/32"
A05979-1012	12	3/8"	27/32"
A05979-1016	16	9/16"	1-1/16"
A05979-1020	20	13/16"	1-7/32"

Brushes shown actual size, except brush sets.

M-O Blick® Academic Synthetic **LONG**handle

We've engineered this filament to be slightly less firm, to make it the best partner for our Studio Synthetic. The brush is interlocked and is a bit fuller in the Flat and Bright shapes to yield a more substantial feel in your hand. Excellent for thinner applications of color. Imparts little evidence of brushstroke to the paint surface.

M Round			
NUMBER	SIZE	DIA	LENGTH
A05368-1000	0	1/32"	5/16"
A05368-1002	2	1/16"	7/16"
A05368-1004	4	3/32"	21/32"
A05368-1006	6	1/8"	3/4"
A05368-1008	8	5/32"	27/32"
A05368-1012	12	9/32"	1-5/32"
A05368-1016	16	3/8"	1-7/16"
A05368-1020	20	9/16"	1-11/16"
A05368-1024	24	11/16"	2"

6-Brush Set — Sizes: 2, 4, 6, 8, 12, and 16.			
NUMBER	EACH	6/EA	12/EA
A05368-0069	\$48.68	\$43.81	

N Flat			
NUMBER	SIZE	WIDTH	LENGTH
A05369-1000	0	1/32"	3/16"
A05369-1002	2	3/32"	1/4"
A05369-1004	4	5/32"	5/16"
A05369-1006	6	3/16"	15/32"
A05369-1008	8	1/4"	9/16"
A05369-1012	12	3/8"	13/16"
A05369-1016	16	9/16"	29/32"
A05369-1020	20	13/16"	1-3/32"
A05369-1024	24	31/32"	1-1/4"

6-Brush Set — Sizes: 2, 4, 6, 8, 12, and 16.			
NUMBER	EACH	6/EA	12/EA
A05369-0069	\$45.50	\$40.95	

O Bright			
NUMBER	SIZE	WIDTH	LENGTH
A05370-1000	0	1/32"	7/64"
A05370-1002	2	3/32"	3/16"
A05370-1004	4	5/32"	1/4"
A05370-1006	6	3/16"	11/32"
A05370-1008	8	1/4"	3/8"
A05370-1012	12	3/8"	19/32"
A05370-1016	16	9/16"	21/32"
A05370-1020	20	13/16"	27/32"
A05370-1024	24	31/32"	1-1/32"

6-Brush Set — Sizes: 2, 4, 6, 8, 12, and 16.			
NUMBER	EACH	6/EA	12/EA
A05981-1009	\$28.13	\$25.32	

BLICK® studio

brushes for the professional artist

- excellent craftsmanship
- seamless nickel-plated brass ferrules
- lacquered wood handles



A-F Blick Studio Natural Bristle LONG handle

Lots of great shapes and great looks too! Unbleached natural bristle set on rich lacquered handles, individually sized to balance each size head. Many customers will appreciate our Egbert offering. Essentially elongated Filberts, these brushes have become truly rare.

A Round

NUMBER	SIZE	DIA	LENGTH	EACH	12/EA
A05910-1000	0	1/32"	5/16"	\$10.68	\$9.61
A05910-1002	2	1/16"	9/16"	11.68	10.51
A05910-1004	4	3/32"	23/32"	12.76	11.49
A05910-1006	6	1/8"	13/16"	14.18	12.76
A05910-1008	8	5/32"	15/16"	15.68	14.12
A05910-1010	10	7/32"	1"	17.10	15.39
A05910-1012	12	9/32"	1-3/16"	19.19	17.27
A05910-1014	14	5/16"	1-9/32"	21.69	19.52
A05910-1016	16	3/8"	1-13/32"	24.20	21.78
A05910-1018	18	15/32"	1-9/16"	27.54	24.78
A05910-1020	20	9/16"	1-13/16"	31.71	28.54
A05910-1024	24	11/16"	2-1/16"	39.22	35.30

5-Brush Set — Sizes: 0, 2, 6, 10, and 14.

NUMBER	EACH	6/EA
A05910-0059	\$71.42	\$64.28

B Flat

NUMBER	SIZE	WIDTH	LENGTH	EACH	12/EA
A05911-2000	0	1/32"	9/32"	\$10.82	\$9.74
A05911-2002	2	3/32"	11/32"	11.65	10.49
A05911-2004	4	5/32"	7/16"	12.90	11.61
A05911-2006	6	3/16"	1/2"	14.15	12.73
A05911-2008	8	1/4"	9/16"	15.40	13.86
A05911-2010	10	5/16"	23/32"	16.64	14.98
A05911-2012	12	3/8"	27/32"	17.89	16.11
A05911-2014	14	15/32"	29/32"	19.56	17.61
A05911-2016	16	9/16"	31/32"	22.06	19.85
A05911-2018	18	11/16"	1-3/32"	24.97	22.48
A05911-2020	20	13/16"	1-7/32"	28.30	25.48
A05911-2024	24	31/32"	1-15/32"	34.13	30.72

5-Brush Set — Sizes: 0, 2, 6, 10, and 18.

NUMBER	EACH	6/EA
A05911-0059	\$73.19	\$65.87

C Fan

NUMBER	SIZE	WIDTH	LENGTH	EACH	12/EA
A05915-1002	2	1-5/8"	1-1/8"	\$17.05	\$15.35
A05915-1004	4	1-3/4"	1-3/8"	21.31	19.19
A05915-1006	6	2-1/2"	1-9/16"	24.73	22.26

D Filbert

NUMBER	SIZE	WIDTH	LENGTH	EACH	12/EA
A05912-2000	0	1/32"	9/32"	\$11.09	\$9.98
A05912-2002	2	3/32"	11/32"	11.94	10.75
A05912-2004	4	5/32"	7/16"	13.22	11.90
A05912-2006	6	3/16"	1/2"	14.50	13.05
A05912-2008	8	1/4"	9/16"	15.78	14.20
A05912-2010	10	5/16"	23/32"	17.06	15.36
A05912-2012	12	3/8"	3/4"	18.34	16.51
A05912-2016	16	15/32"	1-1/32"	20.05	18.05
A05912-2020	20	13/16"	1-3/16"	22.61	20.35
A05912-2024	24	31/32"	1-1/2"	34.13	30.72

E Egbert

NUMBER	SIZE	WIDTH	LENGTH	EACH	12/EA
A05914-3004	4	5/32"	7/8"	\$17.06	\$15.35
A05914-3006	6	3/16"	1-1/16"	17.92	16.12
A05914-3008	8	1/4"	1-3/16"	20.48	18.43
A05914-3012	12	3/8"	1-5/8"	23.89	21.50
A05914-3016	16	15/32"	2"	28.99	26.11
A05914-3018	18	11/16"	2-1/4"	34.13	30.72

F Bright

NUMBER	SIZE	WIDTH	LENGTH	EACH	12/EA
A05913-2000	0	1/32"	3/16"	\$10.78	\$9.71
A05913-2002	2	3/32"	9/32"	11.61	10.46
A05913-2004	4	5/32"	5/16"	12.86	11.58
A05913-2006	6	3/16"	11/32"	14.10	12.70
A05913-2008	8	1/4"	13/32"	15.35	13.82
A05913-2010	10	5/16"	1/2"	16.60	14.94
A05913-2012	12	3/8"	19/32"	17.84	16.06
A05913-2014	14	15/32"	21/32"	19.50	17.56
A05913-2016	16	9/16"	23/32"	22.41	20.17
A05913-2018	18	11/16"	13/16"	24.90	22.42
A05913-2020	20	13/16"	15/16"	28.22	25.40
A05913-2024	24	31/32"	31/32"	34.03	30.64

5-Brush Set — Sizes: 0, 2, 6, 10, and 18.

NUMBER	EACH	6/EA
A05913-0059	\$73.19	\$65.87

G-I Blick Studio Synthetic LONG handle

A synthetic brush that feels like genuine bristle! The result of years of development, these individual filaments have the extreme taper of natural bristle and are gently formed with heat to mimic a natural curve. Ideal for water-mixable oil paints, these brushes retain their stiffness in water. They are also less susceptible to the ravages of acrylic paint.

G Round

NUMBER	SIZE	DIA	LENGTH	EACH	6/EA
A05371-1000	0	1/32"	5/16"	\$6.54	\$5.88
A05371-1002	2	1/16"	13/32"	7.28	6.55
A05371-1004	4	3/32"	5/8"	8.03	7.22
A05371-1006	6	1/8"	23/32"	9.51	8.56
A05371-1008	8	5/32"	27/32"	11.37	10.23
A05371-1012	12	9/32"	1-3/16"	13.75	12.37
A05371-1016	16	3/8"	1-3/8"	24.53	22.07
A05371-1020	20	9/16"	1-11/16"	36.80	33.11

H Flat

NUMBER	SIZE	WIDTH	LENGTH	EACH	6/EA
A05372-1000	0	1/32"	5/32"	\$6.31	\$5.68
A05372-1002	2	3/32"	1/4"	7.06	6.35
A05372-1004	4	5/32"	11/32"	8.03	7.22
A05372-1006	6	3/16"	7/16"	9.29	8.36
A05372-1008	8	1/4"	9/16"	10.78	9.69
A05372-1012	12	3/8"	27/32"	13.75	12.37
A05372-1016	16	9/16"	29/32"	21.41	19.26
A05372-1020	20	13/16"	1-3/32"	34.57	31.10

I Bright

NUMBER	SIZE	WIDTH	LENGTH	EACH	6/EA
A05373-1000	0	1/32"	3/32"	\$6.31	\$5.68
A05373-1002	2	3/32"	3/16"	7.06	6.35
A05373-1004	4	5/32"	1/4"	8.03	7.22
A05373-1006	6	3/16"	5/16"	9.29	8.36
A05373-1008	8	1/4"	13/32"	10.78	9.69
A05373-1012	12	3/8"	9/16"	13.75	12.37
A05373-1016	16	9/16"	11/16"	21.41	19.26
A05373-1020	20	13/16"	27/32"	34.57	31.10

Blick Studio Synthetic 4-Brush Set

Sizes: 6 Round, 6 Flat, 4 Bright, and 12 Bright.

NUMBER	EACH	6/EA
A05397-1001	\$30.57	\$27.51

Brushes shown actual size.

BLICK® masterstroke®

brushes for the professional artist

- excellent craftsmanship
- seamless nickel-plated brass ferrules
- matte black solid wood handles

Blick Masterstroke® Finest Red Sable Brushes LONG handle

Only the highest-quality brush hairs find their way into Blick Masterstroke Finest Red Sable Brushes. Every brush is handmade to exacting standards, and imported solely for Blick. Hand-selected and hand-cupped by skilled artisans, the highly resilient hair offers unsurpassed spring, snap, and control. Every brush is hand-glued into a seamless, nickel-plated brass ferrule and securely crimped to a gold-tipped, matte black, solid wood handle.

Round

NUMBER	SIZE	DIA	LENGTH	EACH	12/EA
A04652-1000	0	1/16"	1/4"	\$7.03	\$6.32
A04652-1001	1	5/64"	9/32"	9.14	8.22
A04652-1002	2	5/64"	5/16"	10.54	9.48
A04652-1004	4	3/32"	3/8"	11.95	10.75
A04652-1006	6	7/64"	1/2"	14.06	12.65
A04652-1008	8	9/64"	9/16"	19.69	17.71
A04652-1010	10	5/32"	21/32"	26.72	24.04
A04652-1012	12	11/64"	3/4"	38.68	34.79
A04652-1016	16	13/64"	7/8"	52.75	47.45
A04652-1018	18	7/32"	15/16"	73.85	66.43
A04652-1020	20	1/4"	1"	84.40	75.92

Flat

NUMBER	SIZE	WIDTH	LENGTH	EACH	12/EA
A04651-1001	1	3/32"	5/16"	\$8.43	\$7.59
A04651-1002	2	7/64"	13/32"	11.03	9.92
A04651-1003	3	1/8"	13/32"	12.98	11.68
A04651-1004	4	9/64"	1/2"	18.17	16.35
A04651-1005	5	5/32"	1/2"	22.72	20.44
A04651-1006	6	3/16"	9/16"	32.45	29.20
A04651-1007	7	9/32"	19/32"	45.44	40.88
A04651-1008	8	3/8"	11/16"	60.37	54.32
A04651-1010	10	13/32"	25/32"	68.16	61.32
A04651-1012	12	7/16"	7/8"	84.39	75.93
A04651-1014	14	1/2"	15/16"	107.11	96.37
A04651-1016	16	19/32"	1"	116.85	105.13
A04651-1020	20	43/64"	1-17/64"	142.82	128.50

Filbert

NUMBER	SIZE	WIDTH	LENGTH	EACH	12/EA
A05458-1001	1	1/8"	9/32"	\$11.88	\$10.70
A05458-1002	2	5/32"	5/16"	13.98	12.59
A05458-1003	3	11/64"	23/64"	16.08	14.48
A05458-1004	4	7/32"	25/64"	24.47	22.03
A05458-1006	6	1/4"	15/32"	38.46	34.62
A05458-1008	8	21/64"	35/64"	48.94	44.07
A05458-1010	10	13/32"	5/8"	65.03	58.55
A05458-1012	12	15/32"	3/4"	76.92	69.25
A05458-1014	14	1/2"	53/64"	104.89	94.43
A05458-1020	20	11/16"	1"	139.85	125.91

Bright

NUMBER	SIZE	WIDTH	LENGTH	EACH	12/EA
A04650-1000	0	7/64"	15/64"	\$9.27	\$8.34
A04650-1001	1	1/8"	1/4"	11.99	10.81
A04650-1002	2	5/32"	5/16"	14.76	13.28
A04650-1004	4	7/32"	5/16"	24.72	22.25
A04650-1006	6	1/4"	27/64"	44.64	40.18
A04650-1008	8	21/64"	15/32"	53.57	48.21
A04650-1010	10	12/32"	17/32"	61.81	55.63
A04650-1012	12	15/32"	19/32"	75.55	67.99
A04650-1014	14	1/2"	5/8"	91.35	82.21
A04650-1016	16	9/16"	11/16"	113.33	101.99
A04650-1020	20	11/16"	3/4"	157.98	142.18



Blick Masterstroke® Synthetic Sable 4-Brush Set

The soft, synthetic look and handling of natural sable brushes without the cost! This four-brush set includes one each of Size 4 Flat (long handle), Size 1/4" One-Stroke (short handle), Size 2 Round (long handle), and Size 1 Round (short handle).

NUMBER	EACH	12/EA
A05212-9004	\$17.09	\$15.38

BLICK® masterstroke®

brushes for the professional artist

- excellent craftsmanship
- seamless nickel-plated brass ferrules
- matte black solid wood handles



Blick® Masterstroke® Pure Hog Bristle

LONG handle

This series is one of our finest brush lines, and quite possibly the finest pure hog bristle you'll find anywhere. The very best craftsmanship goes into each brush — from the top-quality, hand-selected white bristle to the accent of gold on the tip of the long, matte black handles. The term "interlocking" refers to the abundance of natural flags, or splits, on the tips of the bristles — deep flags that lock together and produce a smooth stroke, even with heavy paints. Bristles are sorted by the natural curve of the hair and assembled so that the brush naturally retains its shape.

Round

NUMBER	SIZE	DIA	LENGTH	EACH	12/EA
A05223-1001	1	1/8"	7/16"	\$7.92	\$7.13
A05223-1002	2	5/32"	9/16"	8.36	7.53
A05223-1003	3	3/16"	5/8"	8.80	7.92
A05223-1004	4	1/4"	13/16"	9.68	8.72
A05223-1006	6	5/16"	1"	13.21	11.89
A05223-1008	8	3/8"	1-3/16"	16.73	15.06
A05223-1010	10	13/32"	1-3/8"	23.16	20.85
A05223-1012	12	7/16"	1-5/8"	31.27	28.15

Flat

NUMBER	SIZE	WIDTH	LENGTH	EACH	12/EA
A05225-1001	1	7/32"	1/2"	\$7.92	\$7.13
A05225-1002	2	1/4"	17/32"	8.18	7.37
A05225-1003	3	9/32"	11/16"	8.62	7.76
A05225-1004	4	3/8"	23/32"	9.24	8.32
A05225-1006	6	1/2"	27/32"	12.59	11.33
A05225-1008	8	5/8"	15/16"	16.99	15.30
A05225-1010	10	13/16"	1-1/8"	23.60	21.25
A05225-1012	12	15/16"	1-5/16"	32.15	28.94

Skywash — (not shown)

NUMBER	SIZE	WIDTH	LENGTH	EACH	12/EA
A05339-1002	2"	2"	1-3/4"	\$8.98	\$8.08

Filbert

NUMBER	SIZE	WIDTH	LENGTH	EACH	12/EA
A05224-1001	1	7/32"	19/32"	\$7.92	\$7.13
A05224-1002	2	1/4"	5/8"	8.36	7.53
A05224-1003	3	9/32"	3/4"	8.80	7.92
A05224-1004	4	3/8"	7/8"	9.68	8.72
A05224-1006	6	15/32"	1"	13.21	11.89
A05224-1008	8	19/32"	1-1/4"	17.61	15.85
A05224-1010	10	25/32"	1-3/8"	24.66	22.20
A05224-1012	12	7/8"	1-1/2"	33.91	30.53

Bright

NUMBER	SIZE	WIDTH	LENGTH	EACH	12/EA
A05226-1001	1	7/32"	5/16"	\$7.92	\$7.13
A05226-1002	2	1/4"	13/32"	8.18	7.37
A05226-1003	3	9/32"	7/16"	8.62	7.76
A05226-1004	4	13/32"	1/2"	9.24	8.32
A05226-1006	6	15/32"	11/16"	12.59	11.33
A05226-1008	8	19/32"	3/4"	16.73	15.06
A05226-1010	10	25/32"	13/16"	21.84	19.66
A05226-1012	12	15/16"	1"	29.50	26.56

Fan

NUMBER	SIZE	WIDTH	LENGTH	EACH	12/EA
A05323-1102	2	1-3/8"	55/64"	\$9.68	\$8.70

Blick® Masterstroke® Pure Hog Bristle Round 6-Brush Set

Sizes: 2, 4, 6, 8, 10, and 12.

NUMBER	EACH
A05223-9006	\$72.24

Blick® Masterstroke® Pure Hog Bristle Flat 6-Brush Set

Sizes: 2, 4, 6, 8, 10, and 12.

NUMBER	EACH
A05225-9006	\$72.24

Blick® Masterstroke® Pure Hog Bristle Filbert 6-Brush Set

Sizes: 2, 4, 6, 8, 10, and 12.

NUMBER	EACH
A05224-9006	\$75.77

Blick® Masterstroke® Pure Hog Bristle Bright 6-Brush Set

Sizes: 2, 4, 6, 8, 10, and 12.

NUMBER	EACH
A05226-9006	\$69.60



Robert Simmons® Signet Hog Bristle

Every Robert Simmons brush is handmade using high-quality Chungking hog bristle, interlocked and deep-set in an extra-long, seamless, nickel-plated ferrule. Long beechwood handles are treated with five coats of lacquer. Ideal for acrylics and oils, these resilient brushes are guaranteed for life.

Round

NUMBER	SIZE	DIA	EACH	12/EA
A06645-7020	2/0	1/16"	\$6.56	\$5.90
A06645-1000	0	3/32"	6.79	6.11
A06645-1002	2	5/32"	6.99	6.30
A06645-1004	4	7/32"	8.50	7.65
A06645-1006	6	9/32"	10.94	9.85
A06645-1008	8	11/32"	13.12	11.81
A06645-1010	10	7/16"	19.38	17.44
A06645-1012	12	1/2"	22.09	19.88

Flat

NUMBER	SIZE	WIDTH	LENGTH	EACH	12/EA
A06646-1002	2	7/32"	19/32"	\$7.18	\$6.46
A06646-1004	4	13/32"	3/4"	8.31	7.48
A06646-1006	6	15/32"	1"	10.75	9.67
A06646-1008	8	19/32"	1-5/32"	13.08	11.78
A06646-1010	10	13/16"	1-3/8"	19.52	17.57
A06646-1012	12	15/16"	1-9/16"	21.69	19.53

Filbert — (not shown)

NUMBER	SIZE	WIDTH	LENGTH	EACH	12/EA
A06647-1002	2	7/32"	21/32"	\$7.12	\$6.41
A06647-1004	4	3/8"	13/16"	8.31	7.48
A06647-1006	6	15/32"	1"	10.66	9.60
A06647-1008	8	9/16"	1-7/32"	12.98	11.68
A06647-1010	10	3/4"	1-7/16"	19.37	17.43
A06647-1012	12	15/16"	1-1/2"	21.52	19.37

Egbert

NUMBER	SIZE	WIDTH	EACH	12/EA
A05259-0002	2	7/32"	\$6.99	\$6.32
A05259-0004	4	5/16"	8.52	7.67
A05259-0006	6	7/16"	10.84	9.76
A05259-0008	8	9/16"	13.09	11.78

Bright

NUMBER	SIZE	WIDTH	LENGTH	EACH	12/EA
A06644-1002	2	1/4"	13/32"	\$7.10	\$6.39
A06644-1004	4	3/8"	17/32"	8.22	7.40
A06644-1006	6	15/32"	21/32"	10.63	9.57
A06644-1008	8	5/8"	27/32"	12.95	11.65
A06644-1010	10	3/4"	1"	19.39	17.45
A06644-1012	12	1"	1-3/16"	21.47	19.32

Broad — (not shown)

NUMBER	SIZE	WIDTH	EACH	12/EA
A06649-1014	14	1-3/16"	\$32.35	\$29.12
A06649-1016	16	1-3/8"	42.87	38.59
A06649-1018	18	1-9/16"	54.19	48.78
A06649-1020	20	1-15/16"	64.70	58.24
A06649-1022	22	2-3/16"	80.14	72.14
A06649-1024	24	2-3/8"	106.80	96.13

Fan Blender — (not shown)

NUMBER	SIZE	WIDTH	EACH	12/EA
A06648-1002	2	1-5/16"	\$9.32	\$8.38
A06648-1004	4	1-5/8"	11.59	10.43
A06648-1006	6	1-3/4"	13.27	11.94
A06648-1008	8	2-3/16"	14.81	13.33
A06648-1010	10	2-1/4"	17.42	15.68
A06648-1012	12	2-7/8"	21.35	19.21

Utrecht® Natural Chungking Pure Bristle — Series 209

LONG handle

Handmade using only the highest-quality Chinese Chungking hog bristle, these brushes are ideal for use with heavy-bodied colors and for impasto brushwork. The naturally strong curved bristles are cupped with interlocking construction for better control and excellent shape retention. The tips of the hog hairs are flagged, promoting superior paint capacity and even strokes. The nickel-plated seamless ferrules are securely fastened with deep double crimping onto long brown hardwood handles.

Round

NUMBER	SIZE	DIA	LENGTH	EACH	12/EA
A04616-4001	1	1/8"	15/32"	\$6.26	\$5.63
A04616-4002	2	5/32"	9/16"	7.53	6.78
A04616-4004	4	7/32"	13/16"	8.90	7.99
A04616-4006	6	9/32"	1-1/8"	9.30	8.37
A04616-4008	8	11/32"	1-5/16"	12.38	11.15
A04616-4010	10	7/16"	1-1/2"	14.73	13.25
A04616-4012	12	1/2"	1-5/8"	18.05	16.24

Flat

NUMBER	SIZE	WIDTH	LENGTH	EACH	12/EA
A04616-1001	1	1/4"	15/32"	\$5.63	\$5.07
A04616-1002	2	1/4"	19/32"	5.93	5.35
A04616-1004	4	13/32"	25/32"	7.45	6.70
A04616-1006	6	15/32"	15/16"	8.98	8.08
A04616-1008	8	19/32"	1-1/8"	11.40	10.26
A04616-1010	10	13/16"	1-5/16"	16.36	14.72
A04616-1012	12	1"	1-1/2"	20.62	18.56

Filbert

NUMBER	SIZE	WIDTH	LENGTH	EACH	12/EA
A04616-2001	1	7/32"	15/32"	\$5.93	\$5.35
A04616-2002	2	1/4"	19/32"	6.57	5.91
A04616-2004	4	13/32"	25/32"	8.11	7.29
A04616-2006	6	15/32"	15/16"	9.30	8.37
A04616-2008	8	19/32"	1-1/8"	12.05	10.85
A04616-2010	10	13/16"	1-11/32"	16.99	15.31
A04616-2012	12	1-1/32"	1-1/2"	22.20	19.98

Bright

NUMBER	SIZE	WIDTH	LENGTH	EACH	12/EA
A04616-1101	1	7/32"	5/16"	\$5.63	\$5.07
A04616-1102	2	1/4"	11/32"	6.05	5.44
A04616-1104	4	13/32"	1/2"	7.45	6.70
A04616-1106	6	15/32"	5/8"	8.98	8.08
A04616-1108	8	19/32"	13/16"	11.40	10.26
A04616-1110	10	13/16"	15/16"	16.68	14.99
A04616-1112	12	1-1/32"	1-1/8"	20.62	18.56



Utrecht® Manglon Synthetic LONG handle

These unique synthetic blend brushes are constructed with multi-filaments of varying diameters to offer unbelievable snap and shape retention. The filaments are firmly set in seamless, brass-plated black ferrules on a black lacquered handle. Handles are color-coded to denote shape.

Round

NUMBER	SIZE	DIA	LENGTH	EACH	12/EA
A04627-3002	2	3/64"	3/8"	\$7.19	\$6.47
A04627-3004	4	1/16"	15/32"	7.50	6.74
A04627-3006	6	3/32"	1/2"	8.11	7.29
A04627-3008	8	7/64"	9/16"	8.84	7.95
A04627-3010	10	1/8"	5/8"	9.45	8.50
A04627-3012	12	5/32"	3/4"	10.37	9.32
A04627-3016	16	3/16"	7/8"	12.81	11.52

Flat

NUMBER	SIZE	WIDTH	LENGTH	EACH	12/EA
A04627-2102	2	1/8"	11/32"	\$7.62	\$6.85
A04627-2104	4	5/32"	27/64"	8.23	7.40
A04627-2106	6	7/32"	1/2"	8.84	7.95
A04627-2110	10	11/32"	21/32"	10.06	9.05
A04627-2114	14	15/32"	13/16"	11.89	10.69
A04627-2118	18	21/32"	1"	13.72	12.34

Filbert

NUMBER	SIZE	WIDTH	LENGTH	EACH	12/EA
A04627-2002	2	1/8"	5/16"	\$7.50	\$6.74
A04627-2004	4	5/32"	7/16"	8.11	7.29
A04627-2006	6	7/32"	15/32"	9.45	8.50
A04627-2008	8	5/16"	1/2"	10.06	9.05
A04627-2010	10	11/32"	5/8"	10.67	9.60
A04627-2012	12	13/32"	23/32"	11.59	10.42
A04627-2014	14	7/16"	25/32"	13.11	11.79
A04627-2016	16	17/32"	7/8"	14.03	12.62
A04627-2018	18	21/32"	15/16"	15.55	13.99

Bright

NUMBER	SIZE	WIDTH	LENGTH	EACH	12/EA
A04627-1002	2	1/8"	9/32"	\$7.19	\$6.47
A04627-1004	4	3/16"	11/32"	7.50	6.74
A04627-1006	6	7/32"	7/16"	8.11	7.29
A04627-1008	8	21/64"	31/64"	8.84	7.95
A04627-1010	10	23/64"	17/32"	9.45	8.50
A04627-1012	12	7/16"	17/32"	10.37	9.32
A04627-1016	16	9/16"	11/16"	13.11	11.79

Fan

NUMBER	SIZE	WIDTH	LENGTH	EACH	12/EA
A04627-4008	8	2-1/4"	1-7/16"	\$9.14	\$8.22

Utrecht® Manglon Synthetic Set of 4 LONG handle
Includes Round Size 4, Bright Size 8, Filbert Size 12, and Filbert Size 18.

NUMBER	EACH	6/EA
A04635-1009	\$49.55	\$44.59



Raphaël™ Kaërell Brushes LONG handle

The Raphaël Kaërell is the closest thing to a natural hair brush we've found. Supremely soft with a fine tip, it's excellent for watercolor, acrylic, and oil painting. This is a long-wearing brush with excellent water-carrying capacity and surprising strength at an economical price. Durable and easy to clean, this extremely versatile brush can be used for a variety of techniques and media.

Series 869 — Round

NUMBER	SIZE	DIA	LENGTH	EACH	5/EA
A06655-1002	2	1/64"	1/8"	\$7.16	\$6.43
A06655-1004	4	1/32"	1/4"	7.32	6.58
A06655-1006	6	1/16"	13/32"	7.78	6.99
A06655-1008	8	3/32"	9/16"	8.47	7.61
A06655-1010	10	1/8"	11/16"	9.12	8.19
A06655-1012	12	5/32"	25/32"	10.07	9.05
A06655-1014	14	7/32"	7/8"	11.08	9.96
A06655-1016	16	3/16"	31/32"	11.99	10.78
A06655-1018	18	1/4"	1-1/32"	14.35	12.89
A06655-1020	20	7/32"	1-1/8"	14.99	13.48
A06655-1022	22	9/32"	1-5/32"	16.31	14.66
A06655-1024	24	5/16"	1-1/4"	19.58	17.59

Series 879 — Flat

NUMBER	SIZE	WIDTH	LENGTH	EACH	5/EA
A06656-1002	2	3/32"	5/16"	\$8.20	\$7.38
A06656-1004	4	3/16"	3/8"	8.55	7.69
A06656-1006	6	1/4"	15/32"	9.97	8.97
A06656-1008	8	11/32"	17/32"	12.18	10.96
A06656-1010	10	15/32"	19/32"	12.91	11.61
A06656-1012	12	1/2"	5/8"	13.99	12.61
A06656-1014	14	9/16"	3/4"	15.20	13.67
A06656-1016	16	11/16"	13/16"	17.72	15.94
A06656-1018	18	25/32"	7/8"	22.81	20.52
A06656-1020	20	7/8"	15/16"	24.20	21.76
A06656-1022	22	15/16"	1"	27.66	24.88
A06656-1024	24	31/32"	1-1/16"	33.20	29.86

Series 8792 — Filbert

NUMBER	SIZE	WIDTH	LENGTH	EACH	5/EA
A06657-1002	2	3/32"	19/64"	\$10.35	\$9.32
A06657-1004	4	3/16"	3/8"	10.88	9.79
A06657-1006	6	9/32"	7/16"	11.37	10.23
A06657-1008	8	25/64"	9/16"	12.32	11.09
A06657-1010	10	3/8"	11/16"	13.20	11.88
A06657-1012	12	15/32"	25/32"	16.23	14.61
A06657-1014	14	9/16"	7/8"	18.99	17.11
A06657-1016	16	11/16"	29/32"	21.80	19.61
A06657-1018	18	25/32"	1"	28.13	25.32
A06657-1020	20	13/16"	1-3/32"	30.95	27.85
A06657-1022	22	7/8"	1-3/16"	33.77	30.39
A06657-1024	24	15/16"	1-1/4"	41.51	37.36
A06657-1032	32	1-15/32"	2-3/16"	111.16	100.03

Series 8795 — Fan

NUMBER	SIZE	WIDTH	LENGTH	EACH	5/EA
A06658-1002	2	29/32"	19/32"	\$12.83	\$11.55
A06658-1004	4	1-1/8"	23/32"	13.47	12.13
A06658-1006	6	1-5/16"	27/32"	15.11	13.60
A06658-1008	8	1-1/2"	31/32"	17.62	15.86
A06658-1010	10	1-11/16"	1-3/32"	18.81	16.93

Brushes shown actual size.



Winsor & Newton™ University™ White Synthetic LONG handle

A value-priced, all-purpose brush that can be used across multiple media. Whether using watercolors, acrylics, or oils, University brushes provide the beginner, the student, and even the professional painter with an affordable option. Smooth polyester fibers allow for clean, flowing strokes. These long-handled brushes also serve a wide range of craft applications. Available in a variety of styles and sizes.

235 — Round

NUMBER	SIZE	DIA	LENGTH	EACH	12/EA
A05395-1001	1	3/32"	3/8"	\$5.23	\$4.70
A05395-1002	2	3/32"	7/16"	5.56	4.99
A05395-1004	4	5/32"	9/16"	7.06	6.35
A05395-1006	6	3/16"	23/32"	9.94	8.94
A05395-1008	8	8/32"	27/32"	12.10	10.88
A05395-1010	10	9/32"	31/32"	17.73	15.94
A05395-1012	12	5/16"	1-1/16"	22.70	20.42

236 — Flat

NUMBER	SIZE	WIDTH	LENGTH	EACH	12/EA
A05394-1001	1	5/32"	5/16"	\$5.23	\$4.70
A05394-1002	2	5/32"	3/8"	5.55	4.99
A05394-1004	4	1/4"	1/2"	7.19	6.47
A05394-1006	6	5/16"	5/8"	9.94	8.94
A05394-1008	8	13/32"	11/16"	12.10	10.88
A05394-1010	10	17/32"	27/32"	17.72	15.95
A05394-1012	12	5/8"	31/32"	22.69	20.42

237 — Bright

NUMBER	SIZE	WIDTH	LENGTH	EACH	12/EA
A05393-1001	1	5/32"	3/16"	\$5.10	\$4.59
A05393-1002	2	5/32"	1/4"	5.55	4.99
A05393-1004	4	1/4"	5/16"	7.19	6.47
A05393-1006	6	5/16"	7/16"	9.94	8.94
A05393-1008	8	13/32"	12/32"	12.10	10.88
A05393-1010	10	17/32"	21/32"	17.72	15.95
A05393-1012	12	5/8"	3/4"	22.69	20.42

238 — Fan

NUMBER	SIZE	WIDTH	LENGTH	EACH	12/EA
A05392-1001	1	7/8"	3/8"	\$6.93	\$6.23
A05392-1003	3	1-5/32"	7/16"	8.70	7.82
A05392-1006	6	1-5/8"	5/8"	12.95	11.65

Winsor & Newton™ Artisan LONG handle

This unique blend of high-quality synthetic fibers mimics the performance of hog bristle, yet retains its fine point and spring. Best used with waterbased or watersoluble paints, every brush is perfectly balanced for comfort and handling ease. Nickel-plated ferrules and silver lacquered handles.

5522 — Round

NUMBER	SIZE	DIA	LENGTH	EACH	12/EA
A05270-1002	2	7/64"	1/2"	\$6.93	\$6.23
A05270-1004	4	1/8"	19/32"	7.13	6.41
A05270-1006	6	11/64"	23/32"	7.99	7.18
A05270-1008	8	15/64"	7/8"	9.18	8.25
A05270-1012	12	9/32"	1-1/8"	10.99	9.91

5524 — Bright

NUMBER	SIZE	WIDTH	LENGTH	EACH	12/EA
A05272-1002	2	1/8"	5/16"	\$8.26	\$7.43
A05272-1004	4	7/32"	13/32"	8.79	7.91
A05272-1006	6	1/4"	1/2"	9.38	8.44
A05272-1008	8	3/8"	9/16"	10.57	9.52
A05272-1012	12	15/32"	5/8"	12.23	10.99
A05272-1014	14	5/8"	3/4"	15.40	13.86
A05272-1018	18	7/8"	7/8"	19.43	17.49
A05272-1022	22	1"	1-1/8"	24.33	21.89
A05272-1024	24	1"	1-3/8"	32.99	29.69

5523 — Filbert

NUMBER	SIZE	WIDTH	LENGTH	EACH	12/EA
A05271-1002	2	7/32"	9/16"	\$8.26	\$7.42
A05271-1004	4	1/4"	5/8"	8.78	7.90
A05271-1006	6	5/16"	3/4"	9.38	8.43
A05271-1008	8	3/8"	7/8"	10.57	9.50
A05271-1012	12	7/16"	15/32"	12.22	10.98

5525 — Flat

NUMBER	SIZE	WIDTH	LENGTH	EACH	12/EA
A05273-1002	2	5/32"	1/2"	\$8.25	\$7.42
A05273-1004	4	7/32"	19/32"	8.78	7.90
A05273-1006	6	1/4"	21/32"	9.37	8.44
A05273-1008	8	3/8"	13/32"	10.56	9.50
A05273-1012	12	15/32"	15/16"	12.21	10.99

5528 — Fan

NUMBER	SIZE	WIDTH	LENGTH	EACH	12/EA
A05274-1001	1	1-1/2"	13/16"	\$10.30	\$9.27
A05274-1003	3	1-15/16"	1-1/32"	11.99	10.82



Princeton™ Summit™ White Synthetic Series 6100 LONG handle

A better multi-purpose brush that offers fantastic resilience and control. Interlocked hairs hold and absorb more paint and stand up to heavy-body acrylics and water-soluble oils.

Round — (not shown)

NUMBER	SIZE	DIA	LENGTH	EACH	12/EA
A06620-7020	2/0	1/16"	5/16"	\$7.18	\$6.46
A06620-1001	1	1/8"	7/16"	7.60	6.84
A06620-1002	2	1/8"	5/8"	7.78	6.99
A06620-1004	4	3/16"	13/16"	9.29	8.36
A06620-1006	6	1/4"	1"	11.62	10.46
A06620-1008	8	3/8"	1-1/4"	14.63	13.17
A06620-1012	12	1/2"	1-9/16"	26.29	23.66

Flat

NUMBER	SIZE	WIDTH	LENGTH	EACH	12/EA
A06617-1002	2	1/4"	5/8"	\$7.75	\$6.97
A06617-1004	4	3/8"	13/16"	9.29	8.36
A06617-1006	6	1/2"	15/16"	11.62	10.46
A06617-1008	8	5/8"	1-1/8"	14.78	13.30
A06617-1010	10	3/4"	1-1/4"	20.87	18.78
A06617-1012	12	1"	1-1/2"	26.29	23.66
A06617-1016	16	1-3/8"	1-5/8"	38.33	34.49
A06617-1020	20	1-7/8"	2"	52.73	47.45

Filbert

NUMBER	SIZE	WIDTH	LENGTH	EACH	12/EA
A06619-1004	4	3/8"	13/16"	\$10.13	\$9.11
A06619-1006	6	1/2"	15/16"	12.99	11.69
A06619-1008	8	5/8"	1-1/8"	16.46	14.80
A06619-1012	12	1"	1-1/2"	26.03	23.41
A06619-1016	16	1-3/8"	1-3/4"	39.59	35.60

Bright

NUMBER	SIZE	WIDTH	LENGTH	EACH	12/EA
A06618-1002	2	1/4"	3/8"	\$7.78	\$6.99
A06618-1004	4	3/8"	1/2"	9.29	8.36
A06618-1006	6	1/2"	5/8"	11.62	10.46
A06618-1008	8	5/8"	7/8"	14.78	13.30
A06618-1010	10	3/4"	15/16"	20.87	18.78
A06618-1012	12	1"	1-1/4"	26.29	23.66

Angular Bright

NUMBER	SIZE	WIDTH	LENGTH	EACH	12/EA
A06522-1006	6	1/2"	13/16"	\$12.34	\$11.10
A06522-1010	10	13/16"	1-1/4"	22.77	20.49

Fan

NUMBER	SIZE	WIDTH	LENGTH	EACH	12/EA
A06621-1002	2	1-1/2"	7/8"	\$10.09	\$9.08
A06621-1006	6	2-1/4"	1-1/8"	14.48	13.03

Brushes shown actual size.

Princeton™ Aspen™ Series 6500 Synthetic LONG handle

The synthetic bristles in Aspen brushes have the same stiffness as natural bristle but (unlike natural bristle) they stay together regardless of the surface or degree of pressure applied. Acrylics, oils, and water-soluble oils release and glide evenly off these bristles. Polished black handles are made from reforested wood, and matte black ferrules eliminate light reflection when painting on site.

Round

NUMBER	SIZE	DIA	LENGTH	EACH	12/EA
A09158-1120	2/0	3/32"	3/8"	\$8.42	\$7.58
A09158-1002	2	5/32"	5/8"	9.98	8.98
A09158-1004	4	1/4"	13/16"	14.10	12.69
A09158-1006	6	5/16"	1-1/32"	18.18	16.36
A09158-1008	8	3/8"	1-1/4"	23.12	20.80

Flat

NUMBER	SIZE	WIDTH	LENGTH	EACH	12/EA
A09157-1002	2	1/4"	5/8"	\$9.37	\$8.43
A09157-1004	4	13/32"	13/16"	12.63	11.36
A09157-1006	6	15/32"	15/16"	15.17	13.65
A09157-1008	8	5/8"	1-1/8"	21.13	18.99
A09157-1010	10	13/16"	1-5/16"	27.88	25.08
A09157-1012	12	31/32"	1-1/2"	33.72	30.33
A09157-1016	16	1-3/8"	1-11/16"	47.41	42.64
A09157-1020	20	1-13/16"	1-15/16"	59.13	53.18

Bright

NUMBER	SIZE	WIDTH	LENGTH	EACH	12/EA
A09155-1002	2	9/32"	11/32"	\$9.29	\$8.36
A09155-1004	4	13/32"	1/2"	12.63	11.36
A09155-1006	6	1/2"	21/32"	15.17	13.65
A09155-1008	8	5/8"	13/16"	21.13	18.99
A09155-1010	10	25/32"	15/16"	27.88	25.08
A09155-1012	12	1"	1-5/32"	33.72	30.33

Angle Bright

NUMBER	SIZE	WIDTH	LENGTH	EACH	12/EA
A09154-1006	6	1/2"	25/32"	\$17.38	\$15.65
A09154-1010	10	13/16"	1-1/4"	29.65	26.69

Filbert

NUMBER	SIZE	WIDTH	LENGTH	EACH	12/EA
A09156-1002	2	1/4"	19/32"	\$10.76	\$9.68
A09156-1004	4	13/32"	25/32"	14.10	12.69
A09156-1006	6	15/32"	7/8"	17.40	15.66
A09156-1008	8	19/32"	1-1/8"	23.12	20.80
A09156-1010	10	27/32"	1-11/32"	29.76	26.78
A09156-1012	12	15/16"	1-1/2"	37.18	33.46

Short Filbert — (not shown)

NUMBER	SIZE	WIDTH	LENGTH	EACH	12/EA
A09159-1004	4	3/8"	19/32"	\$14.10	\$12.69

Liner

NUMBER	SIZE	WIDTH	LENGTH	EACH	12/EA
A09153-1002	2	3/32"	7/8"	\$8.36	\$7.52

Egbert

NUMBER	SIZE	WIDTH	LENGTH	EACH	12/EA
A09160-1006	6	15/32"	1-7/32"	\$18.24	\$16.41

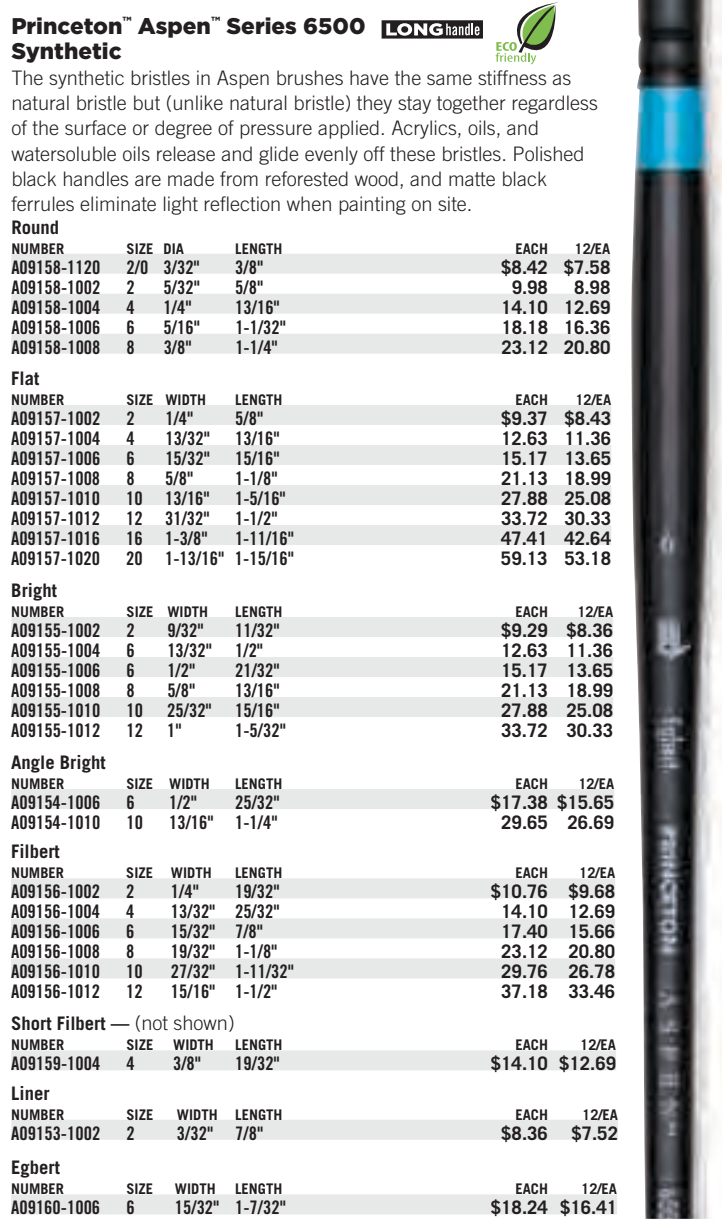

Princeton™ Catalyst™ Polytip™ Series 6400 LONG handle

The tip of each hair has been split to replicate the natural flags on the finest natural bristle, giving Polytip bristles the ability to hold more paint while providing smoother application. Super stiff yet extremely responsive, these brushes are designed for use with medium/heavy body acrylics and oils, and they push even heavy gel mediums with assurance. Unlike natural hog bristle, Polytip brushes have real integrity in water.

Round

NUMBER	SIZE	DIA	LENGTH	EACH	12/EA
A06421-1620	2/0	1/8"	13/32"	\$6.20	\$5.58
A06421-1602	2	9/64"	21/32"	8.30	7.47
A06421-1604	4	7/32"	27/32"	10.48	9.44
A06421-1606	6	9/32"	1-1/32"	12.96	11.67
A06421-1608	8	11/32"	1-9/32"	16.99	15.32
A06421-1610	10	7/16"	1-13/32"	24.62	22.15

Flat

NUMBER	SIZE	WIDTH	LENGTH	EACH	12/EA
A06421-1502	2	1/4"	19/32"	\$9.21	\$8.29
A06421-1504	4	13/32"	13/16"	10.48	9.44
A06421-1506	6	1/2"	31/32"	12.29	11.06
A06421-1510	10	13/16"	1-3/8"	22.25	19.99
A06421-1512	12	1"	1-19/32"	29.20	26.28
A06421-1516	16	1-7/16"	1-3/4"	42.43	38.18
A06421-1520	20	1-7/8"	2-3/16"	56.63	50.97
A06421-1524	24	2-3/8"	2-9/16"	75.12	67.61

Filbert

NUMBER	SIZE	WIDTH	LENGTH	EACH	12/EA
A06421-1302	2	7/32"	5/8"	\$9.21	\$8.29
A06421-1304	4	13/32"	13/16"	12.03	10.82
A06421-1308	8	5/8"	1-5/32"	17.89	16.10
A06421-1310	10	25/32"	1-3/8"	25.48	22.93
A06421-1312	12	1"	1-9/16"	31.19	28.07
A06421-1316	16	1-7/16"	1-3/4"	46.30	41.67
A06421-1320	20	1-7/8"	2-5/16"	70.46	63.41

Short Filbert

NUMBER	SIZE	WIDTH	LENGTH	EACH	12/EA
A06421-1404	4	13/32"	15/32"	\$11.24	\$10.11
A06421-1408	8	5/8"	3/4"	18.15	16.34
A06421-1412	12	1"	1"	31.99	28.82

Egbert

NUMBER	SIZE	WIDTH	LENGTH	EACH	12/EA
A06421-2006	6	15/32"	1-25/32"	\$16.50	\$14.85
A06421-2012	12	1"	2-9/16"	38.71	34.84

Bright

NUMBER	SIZE	WIDTH	LENGTH	EACH	12/EA
A06421-1202	2	1/4"	13/32"	\$9.21	\$8.29
A06421-1204	4	13/32"	17/32"	10.52	9.47
A06421-1206	6	1/2"	11/16"	12.25	10.99
A06421-1208	8	5/8"	27/32"	17.25	15.52
A06421-1210	10	13/16"	31/32"	22.44	20.19
A06421-1212	12	1"	1-3/16"	29.20	26.28

Angle Bright

NUMBER	SIZE	WIDTH	LENGTH	EACH	12/EA
A06421-1003	3	9/32"	5/8"	\$10.48	\$9.44
A06421-1006	6	1/2"	13/16"	13.57	12.21
A06421-1012	12	1"	1-9/16"	31.19	28.07

Fan

NUMBER	SIZE	WIDTH	LENGTH	EACH	12/EA
A06421-1103	3	2"	1-3/16"	\$12.33	\$11.09
A06421-1106	6	2-7/16"	1-3/8"	16.27	14.64

For Princeton™ Catalyst™ Wedges and Contours, see page 86.



EXCLUSIVE!

Princeton™ Catalyst™ Polytip™ Series 6400 4-Brush Set

This set of four essential brushes includes a Size 10 Flat, Size 8 Filbert, Size 4 Bright, and Size 2 Round.

NUMBER	SIZE	EACH	6/EA
A04416-1049		\$58.53	\$52.68



Not actual size.

Princeton™ Catalyst™ Polytip™ Series 6400 - Mottler

NUMBER	SIZE	WIDTH	LENGTH	EACH	12/EA
A09145-7025	25	1"	2-1/4"	\$19.98	\$17.98
A09145-7050	50	2"	2-1/4"	32.83	29.54
A09145-7075	75	3"	2-1/4"	45.88	41.29
A09145-7100	100	4"	2-1/4"	58.90	52.99

FREE SHIPPING —
Orders of \$49 or more ship free.



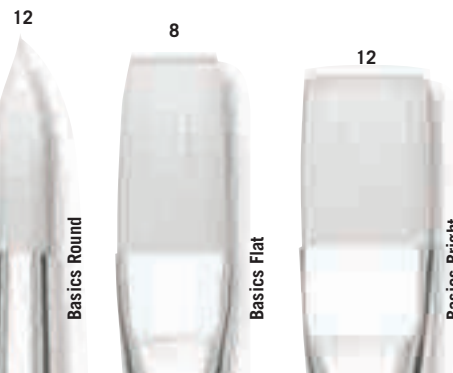

LIQUITEX



Freestyle Giant

Liquitex Basics Brushes LONG handle

The perfect complement to Liquitex Basics, other acrylic paints, and even water-mixable oil colors. Medium-soft white nylon bristles are durable, easy to clean, and hold ample amounts of color, providing ideal responsiveness for soft-bodied to medium-bodied acrylics. An economical price makes them perfect for students, amateurs, or professionals.

Round

NUMBER	SIZE	DIA	LENGTH	EACH	12/EA
A09124-1001	1	5/64"	15/32"	\$2.97	\$2.67
A09124-1002	2	7/64"	17/32"	2.97	2.67
A09124-1003	3	5/32"	39/64"	2.97	2.67
A09124-1004	4	3/16"	11/16"	2.97	2.67
A09124-1005	5	13/64"	3/4"	4.96	4.46
A09124-1006	6	15/64"	55/64"	4.96	4.46
A09124-1008	8	1/4"	1"	4.96	4.46
A09124-1010	10	5/16"	1-1/16"	7.44	6.69
A09124-1012	12	21/64"	1-5/32"	7.44	6.69

Flat

NUMBER	SIZE	WIDTH	LENGTH	EACH	12/EA
A09125-1001	1	9/64"	1/2"	\$2.97	\$2.67
A09125-1002	2	1/4"	17/32"	2.97	2.67
A09125-1003	3	9/32"	19/32"	2.97	2.67
A09125-1004	4	11/32"	13/16"	2.97	2.67
A09125-1005	5	3/8"	53/64"	4.96	4.46
A09125-1006	6	31/64"	7/8"	4.96	4.46
A09125-1008	8	9/16"	1-1/32"	4.96	4.46
A09125-1010	10	19/32"	1-3/32"	7.44	6.69
A09125-1012	12	11/16"	1-3/16"	7.44	6.69

Filbert — (not shown)

NUMBER	SIZE	WIDTH	LENGTH	EACH	12/EA
A09126-1001	1	9/64"	1/2"	\$2.97	\$2.67
A09126-1002	2	1/4"	35/64"	2.97	2.67
A09126-1003	3	19/64"	19/32"	2.97	2.67
A09126-1004	4	11/32"	25/32"	2.97	2.67
A09126-1005	5	3/8"	53/64"	4.96	4.46
A09126-1006	6	15/32"	57/64"	4.96	4.46
A09126-1008	8	17/32"	61/64"	4.96	4.46
A09126-1010	10	35/64"	1-1/32"	7.44	6.69
A09126-1012	12	21/32"	1-11/64"	7.44	6.69

Bright

NUMBER	SIZE	WIDTH	LENGTH	EACH	12/EA
A09128-1001	1	5/32"	21/64"	\$2.97	\$2.67
A09128-1002	2	1/4"	23/64"	2.97	2.67
A09128-1003	3	9/32"	7/16"	2.97	2.67
A09128-1004	4	11/32"	15/32"	2.97	2.67
A09128-1005	5	23/64"	17/32"	4.96	4.46
A09128-1006	6	31/64"	41/64"	4.96	4.46
A09128-1008	8	9/16"	23/32"	4.96	4.46
A09128-1010	10	37/64"	51/64"	7.44	6.69
A09128-1012	12	11/16"	59/64"	7.44	6.69

Fan — (not shown)

NUMBER	SIZE	WIDTH	LENGTH	EACH	12/EA
A09127-1002	2	1-3/16"	3/4"	\$2.97	\$2.67
A09127-1004	4	1-11/64"	7/8"	2.97	2.67
A09127-1006	6	1-5/8"	1-9/64"	4.96	4.46
A09127-1008	8	1-7/8"	1-9/32"	4.96	4.46

Liquitex Basics Brush Sets

Economical and practical, these quality acrylic brushes work great for students and professionals. For set contents, visit DickBlick.com.

NUMBER	DESCRIPTION	EACH	6/EA
A06551-1004	Set of 4	\$6.88	\$6.19
A06551-1005	Set of 5	6.88	6.19
A06551-1006	Set of 6	6.88	6.19



Liquitex Freestyle™ Large Scale

Designed to meet the expanding needs of acrylic artists working on a grand scale. Large, non-slip, matte handles are crafted from high-quality wood, and paired with top-of-the-line synthetic bristle heads that are glued and attached with screws to rustproof, stainless steel ferrules.

Short Handle Flat — This brush is ideal for dragging, figuring, and varnishing large surfaces and walls with broad, gestural strokes.

NUMBER	SIZE	WIDTH	LENGTH	EACH	6/EA
A09110-1004	4"	3-15/16"	2"	\$35.47	\$31.92
A09110-1006	6"	6"	2-1/8"	42.56	38.31
A09110-1008	8"	8"	2-5/16"	49.66	44.69

Long Handle Broad Flat — The long handle on this brush is easy to grip, for quick, broad, gestural strokes on large-scale work or for varnishing.

NUMBER	SIZE	WIDTH	LENGTH	EACH	6/EA
A09109-1001	1"	1"	1-1/2"	\$14.18	\$12.76
A09109-1002	2"	2"	1-5/8"	21.28	19.15
A09109-1003	3"	3"	1-11/16"	28.37	25.54
A09109-1004	4"	4"	1-25/32"	35.47	31.92

Universal Flat — A great all-purpose brush, ideal for priming canvas, murals, gesso application, spreading, and laying in background colors.

NUMBER	SIZE	WIDTH	LENGTH	EACH	6/EA
A09118-1001	1"	1"	2-1/16"	\$12.89	\$11.60
A09118-1002	2"	2"	2-7/15"	19.98	17.99
A09118-1003	3"	3"	3-1/4"	28.36	25.53

Angle — Ideal for surfaces with corners and edges, use this all-purpose brush for gesso application, covering large surfaces and edges, and spreading.

NUMBER	SIZE	WIDTH	LENGTH	EACH	6/EA
A09117-1001	1"	1"	2"	\$12.89	\$11.60
A09117-1002	2"	2"	2-3/8"	19.98	17.99
A09117-1003	3"	3"	3-1/4"	28.36	25.53

Splatter — Great for creating unique splatter effects, these brushes are ideal for use with soft-body acrylic colors or acrylic inks. Round and Flat shapes create different marks.

NUMBER	SHAPE	WIDTH	LENGTH	EACH	6/EA
A09116-1010	Round	1/2"	4-11/16"	\$10.96	\$9.86
A09116-1020	Flat	29/32"	4-11/16"	10.96	9.86

Paddle — Useful for painting broad marks and edges, covering large surfaces, spreading thick color, smoothing, smudging, and scumbling.

NUMBER	SIZE	WIDTH	LENGTH	EACH	6/EA
A09114-1001	1"	1"	27/32"	\$9.66	\$8.70
A09114-1002	2"	2"	1-1/32"	16.75	15.08
A09114-1003	3"	3"	1-9/32"	23.84	21.46
A09114-1004	4"	4"	1-13/32"	30.93	27.84

Giant — This brush holds a large amount of paint, ideal for covering a large area quickly in large-scale applications. Its handle can be unscrewed so the brush can be attached to a broom handle.

NUMBER	SIZE	WIDTH	LENGTH	EACH	6/EA
A09113-5055	5-1/2"	5-1/2"	3-3/8"	\$54.17	\$48.75

BLICK® mega brushes SHORT handle

Blick Mega Brushes are perfect for big projects! High-quality brush hairs are set in nickel-plated brass ferrules, assuring smooth performance, reliability, and longevity. All are securely bonded to short, lacquered hardwood handles with glue and stainless steel nails.



A Blick® Mega Brushes - Natural Bristle

A mid-level of firmness makes this the most spontaneous and expressive of our bristles. SHORT handle

Round

NUMBER	SIZE	DIA	LENGTH	EACH	12/EA
A06206-1015	30	9/16"	1-3/4"	\$13.10	\$11.79
A06206-1019	40	3/4"	2"	15.17	13.65
A06206-1025	50	15/16"	2-3/8"	20.33	18.30

Flat — (not shown)

NUMBER	SIZE	WIDTH	LENGTH	EACH	12/EA
A06208-4112	30	1-3/8"	1-3/8"	\$13.10	\$11.79
A06208-4134	40	1-5/8"	1-1/2"	15.17	13.65
A06208-1002	50	1-15/16"	1-5/8"	20.33	18.30

Filbert

NUMBER	SIZE	WIDTH	LENGTH	EACH	12/EA
A06207-4112	30	1-3/8"	1-1/2"	\$13.10	\$11.79
A06207-4134	40	1-5/8"	1-3/4"	15.17	13.65
A06207-1002	50	1-15/16"	2"	20.33	18.30

B Blick® Mega Brushes - Golden Taklon

A fine, soft-textured, absorbent filament that is exceptionally easy to clean. SHORT handle

Round — (not shown)

NUMBER	SIZE	DIA	LENGTH	EACH	12/EA
A06203-1015	30	9/16"	1-3/4"	\$13.10	\$11.79
A06203-1019	40	3/4"	2"	15.17	13.65
A06203-1025	50	15/16"	2-3/8"	20.33	18.30

Flat — (not shown)

NUMBER	SIZE	WIDTH	LENGTH	EACH	12/EA
A06205-4112	30	1-3/8"	1-3/4"	\$13.10	\$11.79
A06205-4134	40	1-5/8"	1-1/2"	15.17	13.65
A06205-1002	50	1-15/16"	1-5/8"	20.33	18.30

Filbert

NUMBER	SIZE	WIDTH	LENGTH	EACH	12/EA
A06204-4112	30	1-3/8"	1-1/2"	\$13.10	\$11.79
A06204-4134	40	1-5/8"	1-3/4"	15.17	13.65
A06204-1002	50	1-15/16"	2"	20.33	18.30

C Blick® Mega Brushes - White Synthetic

Slightly firmer than Golden Taklon. SHORT handle

Round — (not shown)

NUMBER	SIZE	DIA	LENGTH	EACH	12/EA
A06200-1015	30	9/16"	1-3/4"	\$13.10	\$11.79
A06200-1019	40	3/4"	2"	15.17	13.65
A06200-1025	50	15/16"	2-3/8"	20.33	18.30

Flat

NUMBER	SIZE	WIDTH	LENGTH	EACH	12/EA
A06202-4112	30	1-3/8"	1-3/8"	\$13.10	\$11.79
A06202-4134	40	1-5/8"	1-1/2"	15.17	13.65
A06202-1002	50	1-15/16"	1-5/8"	20.33	18.30

Filbert — (not shown)

NUMBER	SIZE	WIDTH	LENGTH	EACH	12/EA
A06201-4112	30	1-3/8"	1-1/2"	\$13.10	\$11.79
A06201-4134	40	1-5/8"	1-3/4"	15.17	13.65
A06201-1002	50	1-15/16"	2"	20.33	18.30



Blick® Gesso Brushes SHORT handle

Pure white bristle with naturally flagged ends provides a smooth, continuous stroke for priming canvas, varnishing finished works, or employing glazing techniques. Permanently bonded in steel ferrules, so the bristles won't find their way into your painting. The short handles are lacquer-sealed to protect against moisture damage.

NUMBER	SIZE	EACH	12/EA
A06209-1001	1"	\$4.83	\$4.35
A06209-5112	1-1/2"	5.99	5.40
A06209-1002	2"	7.61	6.85
A06209-5212	2-1/2"	8.38	7.55
A06209-1003	3"	9.68	8.71

SHOWN ACTUAL SIZE

Natural Bristle Filbert 40



A Blick® Masterstroke® Eclipse Outliner SHORT handle

Extremely long-haired brushes with square tips, perfect for striping and outlining type. The short handle offers great control and is mounted with seamless nickel-plated ferrules.

NUMBER	SIZE	WIDTH	LENGTH	EACH	12/EA
A05536-7030	3/0	1/32"	1-11/16"	\$7.99	\$7.20
A05536-7020	2/0	3/64"	1-11/16"	8.08	7.28
A05536-1000	0	1/16"	1-11/16"	8.25	7.43
A05536-1001	1	5/64"	1-11/16"	8.42	7.58
A05536-1002	2	3/32"	1-11/16"	8.67	7.81
A05536-1003	3	7/64"	1-11/16"	9.26	8.34
A05536-1004	4	1/8"	1-11/16"	10.52	9.48
A05536-1006	6	5/32"	1-11/16"	12.46	11.22
A05536-1010	10	13/64"	1-11/16"	16.42	14.79

B Blick® Masterstroke® Eclipse One-Stroke SHORT handle

The Eclipse One-Stroke has an extra-long shape that holds a superior load of color, and the square end delivers a reliable sharp edge. Seamless nickel-plated ferrules on short lacquered handles.

NUMBER	SIZE	WIDTH	LENGTH	EACH	12/EA
A05538-4116	1/16"	1/16"	1"	\$5.70	\$5.13
A05538-4018	1/8"	1/8"	1-1/8"	6.04	5.43
A05538-4014	1/4"	1/4"	1-1/4"	7.38	6.64
A05538-4038	3/8"	3/8"	1-3/8"	9.26	8.33
A05538-4012	1/2"	1/2"	1-1/2"	12.08	10.87
A05538-4034	3/4"	3/4"	1-3/4"	20.47	18.42

C Blick® Economy One-Stroke SHORT handle

A low-cost lettering brush with a mixture of soft, natural hairs that form a sharp, reliable edge. Set in a seamless aluminum ferrule on a short, green-lacquered handle.

NUMBER	SIZE	WIDTH	LENGTH	EACH	12/EA
A05511-4014	1/4"	1/4"	5/8"	\$2.35	\$2.11
A05511-4012	1/2"	1/2"	7/8"	3.10	2.78
A05511-4034	3/4"	3/4"	1"	5.57	4.99
A05511-1001	1"	1"	1-1/8"	8.57	7.70

Set of 4 — Sizes: 1/4", 1/2", 3/4", and 1".

NUMBER	SIZE	WIDTH	LENGTH	EACH	6/EA	12/EA
A05511-9004				\$15.55	\$9.85	\$13.96

D Blick® Economy White Bristle Stencil Brushes SHORT handle

These exceptionally affordable flat-head brushes feature 100% hog bristle made especially for stencil application, which requires a tapping technique. Short, natural wood handles with round, seamless aluminum ferrules.

NUMBER	SIZE/DIA	LENGTH	EACH	12/EA	24/EA
A05167-4014	1/4"	19/32"	\$1.29	\$1.16	\$1.10
A05167-4038	3/8"	3/4"	1.56	1.40	1.33
A05167-4012	1/2"	1"	2.12	1.90	1.81
A05167-4058	5/8"	1-1/8"	2.90	2.60	2.48
A05167-1001	1"	1-5/16"	4.14	3.71	3.53

Set of 3 — Sizes: 1/4", 3/8", and 1/2".

NUMBER	SIZE	WIDTH	LENGTH	EACH	6/EA	12/EA
A05167-0039				\$4.21	\$3.79	\$3.60

E Blick® Scholastic White Bristle Stencil Brushes SHORT handle

A good stencil brush is a must for decorative or mural painting. These 100% hog bristle brushes are reasonably priced and contain a better-quality hair for a cleaner look when stenciling. Every brush has a short, natural wood handle with a round, seamless aluminum ferrule.

NUMBER	SIZE/DIA	LENGTH	EACH	12/EA	24/EA
A05691-4014	1/4"	9/16"	\$2.15	\$1.93	\$1.83
A05691-4038	3/8"	21/32"	4.50	4.04	3.83
A05691-4012	1/2"	29/32"	5.44	4.88	4.63
A05691-4058	5/8"	1"	6.56	5.89	5.59
A05691-1001	1"	1"	8.25	7.41	6.99

F Mack™ Sword Stripping Brush SHORT handle

This hand-crafted brush contains the very finest 100% unmixed blue squirrel hair with a blue thread ferrule. Incomparable quality for pinstripping and scroll work.

NUMBER	SIZE	WIDTH	EACH	12/EA
A05557-7030	000	3/16"	\$15.14	\$13.62
A05557-7020	00	7/32"	15.58	13.99
A05557-1000	0	1/4"	16.25	14.62
A05557-1001	1	5/16"	16.65	14.98
A05557-1002	2	13/32"	17.67	15.90

G-I R&F™ Encaustic Brushes SHORT handle

Specifically designed to meet the unique demands of encaustic painting. Most significantly, the use of high-quality natural Chungking hog bristle and natural hair rather than synthetic fibers prevents these brushes from melting and scorching on heated surfaces. Each brush has a unique mid-length handle designed specifically for tabletop painting on encaustic surfaces.

NUMBER	SIZE	DIA	EACH	6/EA
A06417-1006	6	15/64"	\$7.17	\$6.45
A06417-1008	8	5/16"	8.17	7.35
A06417-1010	10	25/64"	9.48	8.52
A06417-1012	12	7/16"	11.68	10.51
A06417-1016	16	1/2"	16.70	14.99
A06417-1020	20	19/32"	18.80	16.91

NUMBER	SIZE	WIDTH	EACH	6/EA
A06415-1008	8	21/32"	\$9.56	\$8.60
A06415-1010	10	7/8"	10.62	9.56
A06415-1012	12	15/16"	13.10	11.79
A06415-1014	14	1-1/8"	15.53	13.97
A06415-1016	16	1-7/16"	17.96	16.15
A06415-1020	20	1-7/8"	26.25	23.62

NUMBER	SIZE	WIDTH	EACH	6/EA
A06415-4034	3/4"	3/4"	\$13.10	\$11.79
A06415-1001	1"	1"	15.53	13.97
A06415-5114	1-1/2"	1-1/2"	28.28	25.44

NUMBER	SIZE	WIDTH	EACH	6/EA
A06414-1010	10	7/8"	\$10.53	\$9.47
A06414-1012	12	15/16"	12.99	11.68
A06414-1016	16	1-13/32"	17.80	15.99

NUMBER	SIZE	WIDTH	EACH	6/EA
A06412-1008	8	21/32"	\$9.60	\$8.64
A06412-1010	10	7/8"	10.67	9.60
A06412-1012	12	31/32"	13.16	11.84
A06412-1014	14	1-1/8"	15.59	14.03
A06412-1016	16	1-13/32"	18.03	16.23
A06412-1020	20	1-29/32"	26.36	23.73

NUMBER	SIZE	WIDTH	EACH	6/EA
A06413-1004	4	1-9/16"	\$7.23	\$6.51
A06413-1008	8	2-3/16"	9.56	8.60
A06413-1012	12	2-11/16"	13.10	11.79



J Yasutomo® Student Hake Brushes SHORT handle

Perfect for students, this brush made from sheep hair is a less costly version of a classic Hake brush. Each brush has a hole in the handle for hanging. The brush comes to a sharp point edge when wet and holds a generous amount of ink or water for saturated washes.

NUMBER	WIDTH	LENGTH	EACH	6/EA
A05419-2001	1"	1"	\$13.27	\$11.96
A05419-2015	1-1/5"	1"	16.82	15.16
A05419-2025	2-1/2"	1"	25.14	22.66
A05419-2003	3"	1"	29.27	26.39

K Yasutomo® Hake Brushes SHORT handle

These professional-grade wash brushes contain super-soft sheep hair that's carefully selected and hand-stitched into a one-piece hand-split handle. They can be used with a wide range of media and are well-suited for ceramic art. Due to the nature of these handmade brushes, there may be slight variations in size and hair length.

NUMBER	WIDTH	LENGTH	EACH	12/EA
A05425-1001	1"	2"	\$2.78	\$2.51
A05425-4015	1-1/2"	2"	4.45	3.99
A05425-4187	1-7/8"	2"	5.62	5.07
A05425-4025	2-1/2"	2"	6.95	6.28
A05425-4325	3-1/4"	2"	9.06	8.18
A05425-4387	3-7/8"	2"	10.45	9.44
A05425-4055	5-1/2"	2"	13.90	12.55

L Yasutomo® Flat Hake Brushes SHORT handle

These sheep hair brushes can be used with a wide range of media. A metal ferrule protects the brush roots. Inexpensive and long-lasting.

NUMBER	WIDTH	LENGTH	EACH	12/EA
A05408-1001	1"	1-1/4"	\$3.53	\$3.17
A05408-5138	1-3/8"	1-1/4"	4.08	3.66
A05408-5134	1-3/4"	1-1/4"	4.93	4.43
A05408-5212	2-1/2"	1-3/8"	6.63	5.96
A05408-5314	3-1/4"	1-1/2"	8.89	7.98
A05408-5378	3-7/8"	1-1/2"	10.10	9.07
A05408-5458	4-5/8"	1-1/2"	12.42	11.15

M Yasutomo® Bamboo Brushes SHORT handle

Selected fine-quality hair is combined to form this excellent all-purpose brush. Because of its sharp tip and firm body, it performs various strokes well while still being flexible enough for shading and coloring. Also recommended for watercolor.

NUMBER	SIZE	DIA	LENGTH	EACH	12/EA
A05414-1000	0	3/32"	3/4"	\$8.88	\$7.99
A05414-1002	2	5/32"	15/16"	10.89	9.80
A05414-1004	4	1/4"	1-1/4"	15.51	13.95
A05414-1006	6	3/8"	1-11/16"	22.93	20.63

N Blick® Bamboo Brushes SHORT handle

A long, tapered point of soft, dyed goat hair for watercolors, ink, and Japanese calligraphic lettering and sumi-e painting. Hand-set in a plastic ferrule with a bamboo handle.

NUMBER	SIZE	DIA	LENGTH	EACH	12/EA
A05409-1002	2	7/32"	1-1/16"	\$3.63	\$3.27
A05409-1004	4	5/16"	1-1/4"	4.92	4.43
A05409-1006	6	7/16"	1-3/4"	6.43	5.79

3-Brush Set — Sizes: 2, 4, and 6.

NUMBER	SIZE	EACH	6/EA
A05412-9003		\$7.92	\$7.13

O Blick® White Goat Hair Bamboo Brushes SHORT handle

The soft white goat hair in this brush tapers to a workable point. The short handmade bamboo handle works well for ceramics, watercolors, sumi-e, and calligraphy.

NUMBER	SIZE	DIA	LENGTH	EACH	12/EA
A05402-1008	8	5/32"	1/2"	\$6.23	\$5.60
A05402-1016	16	1/4"	1"	7.34	6.59
A05402-1025	25	3/8"	1-7/8"	9.63	8.65

P Blick® Brown Hair Sumi Brush SHORT handle

This pointed-hair brush is great for Japanese calligraphic writing or painting. It is handmade with a bamboo handle and dyed goat hair.

NUMBER	SIZE	DIA	LENGTH	EACH	12/EA
A05401-1001	1	1/4"	1-1/16"	\$5.65	\$5.09
A05401-1002	2	5/16"	1-1/8"	6.63	5.97
A05401-1006	6	3/8"	1-7/8"	11.22	10.10

3-Brush Set — Sizes: 1, 2, and 6.

NUMBER	SIZE	EACH	12/EA
A05410-9003		\$10.95	\$9.85



Blick® Hake Brushes SHORT handle

Handmade in Japan with soft white goat hair, these brushes are useful for blending watercolors and applying gesso, paste, or varnish.

NUMBER	WIDTH	LENGTH	EACH	12/EA
A05403-4058	5/8"	1-3/16"	\$12.07	\$10.86
A05403-1001	1"	1-3/16"	16.77	15.09
A05403-5112	1-1/2"	1-3/16"	20.12	18.11
A05403-1002	2"	1-3/16"	26.83	24.15
A05403-1003	3"	1-3/16"	40.25	36.23

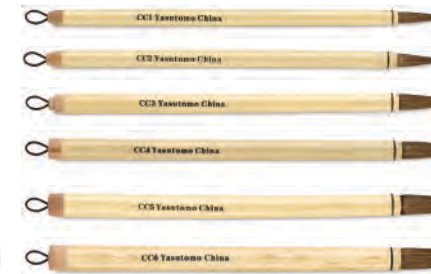

Yasutomo® Bamboo Calligraphy Brushes

Unlike watercolor brushes, oil brushes, and most other paintbrushes, sumi brushes are composed of two separate parts — a core composed of relatively stiff hairs gathered to form a tapered point, and an outer wrapping of softer hairs selected for their ability to hold water and facilitate smooth strokes. Both come together in a point when dipped into water. This structure ensures smooth maneuverability and dynamic strokes under light or heavy pressure.

NUMBER	SIZE	DIA	LENGTH	EACH	12/EA
A05418-1001	1	9/32"	1-3/16"	\$4.17	\$3.74
A05418-1002	2	5/16"	1-7/32"	4.45	3.99
A05418-1003	3	11/32"	1-1/2"	4.78	4.28
A05418-1004					

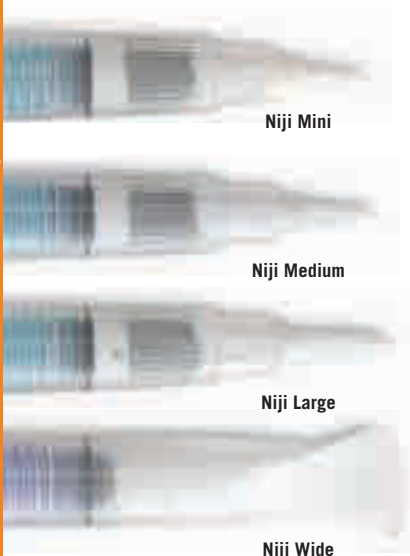

Niji Mini

Niji Medium

Niji Large

Niji Wide

Niji Waterbrush

SHORT handle

A brush and water container in one!

Great for watercoloring, rubber stamping, sketching, and more. Squeeze/fill the water reservoir, screw on the brush tip, and you're ready to go! Squeeze gently to wet the brush and keep it moist. Eliminates continually dipping your brush! Great for travel.

NUMBER	DESCRIPTION	EACH	12/EA
A05133-1003	Mini, 12 mm Tip	\$11.60	\$10.44
A05133-1000	Small, 9 mm Tip	10.65	9.59
A05133-1001	Medium, 12 mm Tip	12.37	11.13
A05133-1002	Large, 15 mm Tip	12.94	11.64
A05133-1012	Wide, 12 mm Tip	16.20	14.57



Set 1

Set 2

Molotow Aqua Squeeze Pen Sets

SHORT handle

Coloring and painting are a piece of cake with Molotow Aqua Squeeze Pens. These sophisticated application tools are easy to fill with water, fluid watercolors, or inks. Mix your own colors, thin them with water, refill, repeat! The water/paint flow is regulated by squeezing the pen's body. Individual pens available online. Great for kids!

Set 1 — Includes three brushes, one each of 1 mm, 3 mm, and 4 mm.

NUMBER	EACH	12/EA
A05454-1019	\$19.71	\$17.75

Set 2 — Includes six brushes, one each of 1 mm, 2 mm, 3 mm, 4 mm, 7 mm, and 10 mm.

NUMBER	EACH	12/EA
A05454-1029	\$44.17	\$39.75

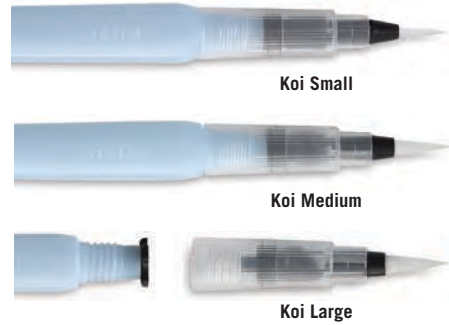

Koi Small

Koi Medium

Koi Large

Sakura Koi Water Brush

SHORT handle

This handy brush carries the water for you! Designed for easy transport and storage, the Koi Water Brush separates into two parts — a fine, flexible brush tip and a barrel handle with a plug. The comfortable grip is great for controlled blending, shading, and highlighting. All three sizes have a 9 ml water tank.

NUMBER	DESCRIPTION	SIZE	EACH	6/EA
A09094-1010	Small	2 Round	\$6.33	\$5.70
A09094-1020	Medium	6 Round	6.33	5.70
A09094-1030	Large	8 Round	6.33	5.70

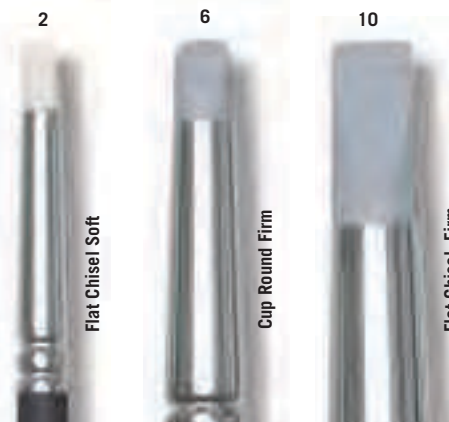

Colour Shapers™

Invented by artists for artists, Colour Shapers combine tradition with exciting new technology. The durable tips are made of an advanced rubber composite, ideal for carving back into oil or acrylic paint and creating surface effects. Don't worry — dried color just peels away! The soft ivory-colored tip is designed for responsiveness with fluid and soft colors, and the firm gray tip offers better control over heavy-bodied paints. All are encased in seamless nickel ferrules, attached to lacquered hardwood handles. Choose your size, shape, and firmness from the chart below, or try a sampler set of five.

DESCRIPTION	SIZE 2	SIZE 6	SIZE 10
Soft Taper Point	A04935-0201	A04935-0603	A04935-1001
Soft Cup Round	A04935-0202	A04935-0604	A04935-1002
Soft Cup Chisel	A04935-0203	A04935-0605	A04935-1003
Soft Flat Chisel	A04935-0204	A04935-0606	A04935-1004
Soft Angle Chisel	A04935-0205	A04935-0607	A04935-1005
Firm Taper Point	A04935-0208	A04935-0609	A04935-1006
Firm Cup Round	A04935-0209	A04935-0610	A04935-1007
Firm Cup Chisel	A04935-0210	A04935-0611	A04935-1008
Firm Flat Chisel	A04935-0211	A04935-0612	A04935-1009
Firm Angle Chisel	A04935-0212	A04935-0613	A04935-1010
	EACH \$12.21	EACH \$14.83	EACH \$22.51
	6/EA 10.99	6/EA 13.35	6/EA 20.26

Colour Shaper Sets of 5 — One of each tip: Taper Point, Cup Round, Cup Chisel, Flat Chisel, and Angle Chisel. Available in firm or soft tips.

NUMBER	SIZE	SET	EACH	6/EA
A04935-0206	2	5 Soft Tips	\$44.13	\$39.72
A04935-0207	2	5 Firm Tips	44.13	39.72
A04935-0602	6	5 Soft Tips	61.82	55.63
A04935-0608	6	5 Firm Tips	61.82	55.63

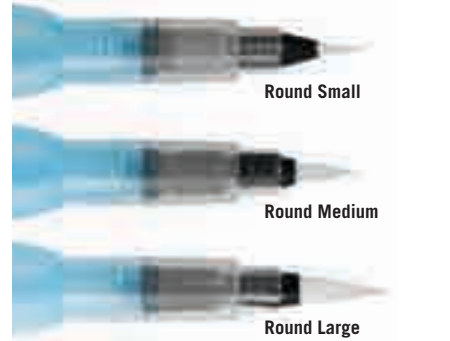

Round Small

Round Medium

Round Large

Pentel Arts Aquash™ Water Brush

SHORT handle

Ideal for sketching and drawing, with durable nylon tips that hold their points for better stroke control, these versatile brushes load easily with water, inks, or fluid colors. The soft, easy-to-squeeze barrels won't roll off surfaces. Great for use with pocket watercolor sets when painting plein air.

NUMBER	DESCRIPTION	EACH	12/EA
A05445-1005	Flat	\$7.62	\$6.85
A05445-1006	Round, Mini	5.33	4.80
A05445-1002	Round, Small	6.65	5.99
A19925-2001	Round, Medium	5.89	5.30
A05445-1001	Round, Large	8.93	8.03

Set of 3 — Includes small, medium, and large.

NUMBER	EACH	12/EA
A05445-1003	\$23.72	\$21.35

Set of 4 — Includes small, medium, large, and flat.

NUMBER	EACH	12/EA
A05445-1004	\$30.35	\$27.30



Colour Shapers™ Mini Sets

Just like their larger counterparts, these are only 1/8" wide, size 0. Sets of five, one of each shape.

NUMBER	SIZE	SET	EACH	6/EA
A04935-0019	0	5 Soft Tips	\$37.03	\$33.32
A04935-0009	0	5 Firm Tips	37.03	33.32



Curve

Flat

Wide Colour Shapers™

Apply and manipulate large amounts of oil or acrylic paints with these extra-wide rubber brushes. The Flat style has a square edge; the Curve style is concave.

NUMBER	DESCRIPTION	EACH	6/EA
A04936-0101	1" Firm Flat	\$15.83	\$14.25
A04936-0213	2" Firm Flat	23.99	21.60
A04936-0102	1" Firm Curve	15.83	14.25
A04936-0214	2" Firm Curve	23.99	21.60



A

B

C

D

E

F

G

A-G Double-Ended Colour Shapers™

The best of both painting worlds — traditional-style brushes on one end and Colour Shapers on the other. A, B, and C are natural bristle; D through G are taklon.

NUMBER	BRUSH/SHAPER SIZE	EACH	6/EA
A04972-1002 A	#2 Round/#2 Tapered	\$13.52	\$12.15
A04972-1003 B	#6 Bright/#6 Flat	19.81	17.80
A04972-1004 C	#6 Mop/#2 Tapered	16.35	14.69
A04972-1005 D	#6 Round/#6 Tapered	14.25	12.81
A04972-1006 E	#6 Bright/#6 Flat	19.81	17.80
A04972-1007 F	#2 Round/#2 Tapered	14.25	12.81
A04972-1008 G	#6 Bright/#6 Flat	19.81	17.80

Pastel Color Shapers™

These double-ended tools are perfect for blending, smudging, and dabbing techniques with your pastel painting and charcoal drawings. One end is soft foam; the other is soft, flat chiseled rubber designed for responsiveness with soft colors.

NUMBER	EACH	6/EA
A04972-1001	\$13.52	\$12.15



Colour Shapers™ Kids Set

Colour Shapers for kids help make the fundamental link between finger painting and a conventional brush, and they retain their shape and outlast any brush. They're easier to clean, too. Kids can use them with all kinds of paint, printmaking, and drawing media, plus clay and papier maché. The set of five includes one each of Cup Round, Flat, Cup, and Angle Chisel, and Taper Point. All are size 6, soft blue rubber. Their colorful handles are kid-sized, too.

NUMBER	EACH	6/EA
A04935-0601	\$26.38	\$23.74



Helpful for individuals with special needs.



Plaid Spouncers

Pounce, stipple, and swirl with this innovative synthetic sponge, featuring a short wooden handle that fits comfortably in the hand. It's ideal for use with stencils and acrylic paints on paper, fabric, walls, and other surfaces.

NUMBER	DESCRIPTION	SIZE	EACH	12/EA
A04314-1002	Medium	1-1/4"	\$2.66	\$2.38
A04314-1003	Large	1-3/4"	3.19	2.86



WonderFoam™ Foam Roller and Paint Tray

Perfect for the classroom, this set contains four easy-to-clean paint rollers in different patterns and a durable, four-section plastic paint tray. The color-coded, easy-grip plastic handles have a hanging loop for ease of drying and storage.

NUMBER	EACH	6/EA
A06039-1049	\$16.39	\$14.75



Foam Paint Rollers

Create unusual effects in watercolors, temperas, and acrylics by rolling the paint on paper, canvas, or any other surface with these foam paint rollers. Try them for fabric painting, window painting, signs, banners, or for any large area that needs covering.

NUMBER	WIDTH	EACH	10/EA	20/EA
A06901-5175	1-3/4"	\$9.75	\$8.77	\$8.33
A06901-5238	2-3/8"	10.57	9.51	9.04



Blick Essentials Value Foam Brushes

These affordable brushes have flexible foam heads attached to sturdy birch handles, for applying paints, stains, or varnishes on artwork, crafts, furniture, and more. Great for all types of artists — students, beginners, and the price-conscious professional, they offer good quality at a reasonable price. Note: Not for use with shellac or lacquer. (Not shown actual size.)

NUMBER	WIDTH	EACH	10/EA	20/EA
A06027-1001	1"	\$0.74	\$6.67	\$6.63
A06027-1002	2"	.99	.91	.86
A06027-1003	3"	1.32	1.20	1.12
A06027-1004	4"	1.53	1.39	1.30

Foam Brush Sets

NUMBER	DESCRIPTION	SIZE	EACH	12/EA
A06280-1409	3-Piece	1 1/2"/3"	\$1.78	\$1.60
A06280-1319	25-Piece	1"	7.95	7.15

Class Pack of 48 — Includes 12 each of 1", 2", 3", and 4".

NUMBER	EACH	10/EA
A06066-1489	\$36.23	\$32.60



H-I Linzer™ Mini Paint Rollers

Great for getting into hard-to-reach areas and covering large areas quickly, Linzer Mini Paint Rollers work well for both general use and fine art applications. Choose foam for thin coats on smooth surfaces and high-touch areas. Choose microfiber for 3X paint-holding ability and a minimum of splatter on both smooth and semi-smooth surfaces. Both measure 4" wide and include a frame and handle.

Impact High-Density Foam

NUMBER	DESCRIPTION	EACH	6/EA
A04301-1020 H	Mini Paint Roller	\$4.64	\$4.17
A04301-1010	Refill 2-Pack	4.39	3.95

ProEdge Microfiber

NUMBER	DESCRIPTION	EACH	6/EA
A04301-1040 I	Mini Paint Roller	\$5.52	\$4.96
A04301-1030	Refill 2-Pack	5.25	4.73



Mini Roller Tray — Made from a durable, solvent-resistant plastic, this disposable tray measures 7" long and fits all Linzer Mini Paint Rollers.

NUMBER	EACH	6/EA
A04301-1050	\$2.61	\$2.35



Blick® Essentials Value All Purpose Brush Sets

Available in a variety of sizes and combinations, these very affordable sets are great for students, beginners, and the price-conscious professional. They offer good quality at a reasonable price, for every type of media, painting technique, and project. Nailed metal ferrules are attached to short, varnished, birch handles that have a convenient hang hole. Sets include one each of Size 1", 2", and 3".

NUMBER	DESCRIPTION	EACH	12/EA
A06280-1009	Brown Nylon	\$5.80	\$5.22
A06280-1019	Bristle	5.80	5.22
A06280-1029	White Nylon	5.80	5.22



A Blick® Masterstroke® Hog Bristle Skywash

SHORT handle

The Skywash is famous for its versatility. A full tuft of good-quality pure white hog bristle fills the flat, nickel-plated steel ferrule. This brush can be used with watercolors for large washes and for wetting paper. With oils or acrylics, it's a useful tool for laying in large areas of color, for priming, or for varnishing. The short, flat handle gives excellent control. Brush hair is approximately 2"W x 1-3/4"L.

NUMBER	SIZE	WIDTH	EACH	12/EA
A05339-1002	2"	1-3/4"	\$8.98	\$8.08

B Blick® Economy White Bristle Gesso

SHORT handle

This pure bristle brush is great for varnishing, glazing, gessoing, and applying finishes of all kinds. Short, natural wood handle.

NUMBER	WIDTH	LENGTH	EACH	12/EA
A05160-4012	1/2"	1-1/2"	\$1.25	\$1.12
A05160-1001	1"	1-1/2"	1.39	1.25
A05160-5112	1-1/2"	1-1/2"	2.09	1.88
A05160-1002	2"	1-1/2"	2.59	2.33
A05160-5212	2-1/2"	1-1/2"	2.89	2.60
A05160-1003	3"	1-1/2"	3.89	3.50

Class Pack of 36 — Includes six brushes of each size listed above.

NUMBER	EACH	6/EA
A05160-0369	\$59.53	\$53.57

C Blick® Scholastic White Bristle Gesso

SHORT handle

Make short work of priming canvas with gesso, varnishing, or working with large-scale paintings. Affordably priced for the classroom budget, these brushes feature short, natural gloss handles designed for comfort while working. Natural flagged-end hog bristle provides smooth coverage with minimal hair loss.

NUMBER	WIDTH	LENGTH	EACH	12/EA	24/EA
A05156-4012	1/2"	1-1/2"	\$6.45	\$5.80	\$5.50
A05156-1001	1"	1-7/16"	7.57	6.80	6.46
A05156-5112	1-1/2"	1-1/2"	8.86	7.97	7.56
A05156-1002	2"	1-11/16"	10.75	9.67	9.18
A05156-5212	2-1/2"	1-3/4"	12.90	11.60	10.99
A05156-1003	3"	1-13/16"	15.05	13.54	12.86

Class Pack of 36 — Includes six brushes of each size listed above.

NUMBER	EACH	6/EA
A05156-0369	\$294.07	\$264.66

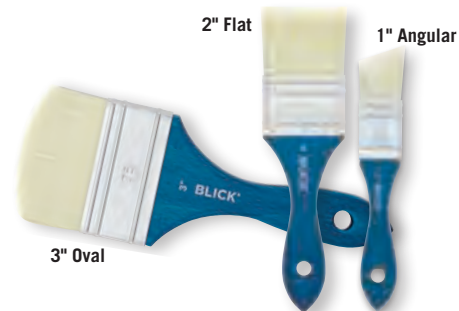

Blick® Mottler Brushes

SHORT handle

The fine, high-quality Falbex synthetic filaments used in our Blick Mottler Brushes adjust smoothly to any surface, guaranteeing full, even paint application — with no brush marks. Suitable for finishing and varnishing, they're also great for applying chalky paints, for glazing, and for creating large-scale murals, with both fine and heavy-body paints. Stainless steel ferrules; ergonomic beechwood handles. Handmade in Germany.

Flat	NUMBER	SIZE	WIDTH	LENGTH	EACH	6/EA
	A06440-1001	1"	1"	1-3/8"	\$10.78	\$9.70
	A06440-1002	2"	2"	1-1/2"	19.93	17.93
	A06440-1003	3"	3"	1-9/16"	32.36	29.11
	A06440-1004	4"	4"	1-5/8"	44.48	40.03

Angular	NUMBER	SIZE	WIDTH	LENGTH	EACH	6/EA
	A06441-1001	1"	1"	1-3/8"	\$13.76	\$12.38
	A06441-1002	2"	2"	1-1/2"	22.91	20.61
	A06441-1003	3"	3"	1-9/16"	42.25	38.03
	A06441-1004	4"	4"	2-5/16"	53.78	48.39

Oval	NUMBER	SIZE	WIDTH	LENGTH	EACH	6/EA
	A06999-1001	1"	1"	1-3/8"	\$13.12	\$11.80
	A06999-1002	2"	2"	1-1/2"	21.99	19.78
	A06999-1003	3"	3"	1-9/16"	40.08	36.05
	A06999-1004	4"	4"	2-1/16"	51.08	45.94



Kids' Brush Holder

This holder keeps up to 24 brushes organized and protected. A wood frame with holes holds a sheet of clear Plexiglas® that is also equipped with holes. Brushes stand upright and at the ready. Measures 5"H x 11"W x 6"D.

NUMBER	EACH	6/EA
A03286-1001	\$33.58	\$30.20



Hebelin® Adjustable Brush Holder

This translucent, 1-1/4" diameter plastic tube telescopes from 8-1/2" to 13" long to accommodate short or long handles.

NUMBER	EACH	12/EA
A06916-0010	\$5.99	\$5.39



Alvin® Prestige™ Paintbrush Holders

Made of durable black nylon with a Velcro® closure, this hardcover holder protects small brushes and tools from damage. An adjustable drawstring cord secures the case so it stands upright, and a stitched elastic band holds brushes in place for easy access. Holds brushes up to 13" long with handles up to 5/8" diameter and folds flat to a convenient 6" x 13-3/4" size.

NUMBER	EACH	6/EA
A06971-1001	\$16.10	\$14.48



D Richeson® Plastic Brush Basin

Soak, shape, store, and wipe fine brushes as you work in this durable, attractive basin. The anti-stick surface accepts any solvent, the bristles are suspended to prevent bending, and the grooves in the bottom aid brush cleaning. 6-1/2" x 6-1/2" x 3-1/2". Includes an air-tight lid. Beige.

NUMBER	EACH	12/EA
A06905-1055	\$7.99	\$7.19

E Mijello™ Water Bucket

Large-capacity (2 liter or 1.8 quart), polypropylene bucket features a highly visible orange handle that folds down to hold and protect active brushes during use. Measures 10" x 6" x 7".

NUMBER	EACH	6/EA
A03319-1001	\$14.63	\$13.16

F Blick® Brush Tube

Made of tough plastic, this handy 2" diameter tube holds dozens of small brushes or several large ones. It's so economical, you can own several! Soft plastic end caps are included.

NUMBER	SIZE	EACH	12/EA
A06926-1012	12"	\$8.95	\$8.06
A06926-1014	14"	9.69	8.73

G Silver Brush® Travel Totes™

Protect your valuable brushes while they dry in these lightweight, breathable, natural canvas travel totes. With individual sewn compartments that accommodate 10 brushes or more, each tote has an extra-long flap that folds over to cover and protect the paintbrush heads. A strong nylon cord wraps around the tote when rolled up, securing brushes for travel and storage. Convenient grommets at the top allow for hanging at a workstation for easy access.

NUMBER	DESCRIPTION	EACH	12/EA
A03359-1001	Short Handle	\$14.60	\$13.14
A03359-1002	Long Handle	14.60	13.14

H Paint Puck® Ultimate Rinse Cup™

This combination brush cleaner and organizer has patented silicone rubber nubs on its base that pull paint away from dirty brushes. This process discourages destructive cleaning habits, extends the life of your brushes, and helps artists create art more quickly and efficiently.

NUMBER	COLOR	EACH	6/EA
A03382-5010	Blue	\$34.97	\$31.47
A03382-3010	Red	34.97	31.47

I Silver Brush® Natural Bamboo Brush Mat

Made from natural bamboo stalks, this handy roll-up mat features 10 brush pockets made from a sheer, breathable material and sewn to the inside. A strap along the top of the mat keeps brushes with longer handles secure. After placing your brushes in the pockets, simply roll up the mat and tie it with the string closure. Great for the studio, storage, and especially plein air painting, it measures 14" x 14" when open.

NUMBER	EACH	12/EA
A03358-8450	\$10.75	\$9.66

J ArtBin® Essentials Brush Box

Protect your delicate and valuable brushes from damage. Foam inserts keep brushes in place while transporting, and vented sides help them dry quickly. Holds up to 20 brushes. Measures 14-3/16" x 6-1/4" x 1-3/16".

NUMBER	EACH	6/EA
A03223-0001	\$17.52	\$15.74



K Silicoil™ Brush Cleaning Tank

Stroking a brush across the smooth surface of the aluminum coil opens and separates the hairs for proper cleaning without damaging the fragile flags (the delicate split ends of brush hairs). The heavy glass tank with screw-on lid holds up to 12 oz of water or solvent.

NUMBER	EACH	12/EA
A06909-1005	\$8.25	\$7.42

L Paint Puck™ Brush Cleaner

Improve your process while you extend the life of your brushes! Simply attach the Paint Puck to the bottom of your rinse cup, can, or bucket, fill the cup with water, then brush the bristles against the soft silicone nubs between color changes. Removes acrylic and watercolor paints from sable, bristle, and synthetic brushes. Note: The Paint Puck may also be used with oil painting solvents, but may expand in size as a result.

NUMBER	COLOR	EACH	5/EA
A03362-2020	Black	\$5.70	\$5.13
A03362-5010	Blue	5.70	5.13
A03362-3510	Earth	5.70	5.13
A03362-7010	Green	5.70	5.13
A03362-3060	Pink	5.70	5.13
A03362-3010	Red	5.70	5.13
A03362-1020	White	5.70	5.13
A03362-4010	Yellow	5.70	5.13
A03362-1010	Pastel, Set of 3	16.53	14.87

M Artist Line Brush Line Hanger

An innovative way of storing artist brushes the correct way — bristles-down — the Brush Line Hanger also keeps brushes at eye-level during painting sessions for quick, easy selection.

Table Mount Hanger — Clamps securely to tabletops up to 2-1/2" thick. Also included are an extendable three-part pole, a central plate, two stainless steel wires (lines), and 10 brush tails. Attach up to eight lines to the Brush Line Stand, for holding up to 120 brushes at a time.

NUMBER	EACH	6/EA
A03377-1001	\$51.31	\$46.18

Canvas/Easel Hanger — Attaches to an easel or canvas stretcher (both regular and gallery wrap stretchers) without disturbing the front of the canvas. For more details, visit DickBlick.com.

NUMBER	EACH	6/EA
A03377-1002	\$30.57	\$27.51

Accessories	NUMBER	DESCRIPTION	EACH	6/EA
	A03377-1003	Brush Tails, 10-Pack	\$10.91	\$9.82
	A03377-1004	Brush Lines, 3-Pack	16.37	14.73



A The Masters® Brush Cleaner & Preserver
The old-fashioned cleaner that's kind to your brushes. Even old, hardened oil paint brushes may be restored to their original snap and luster. Works on all acrylics and watercolors, too. No harmful fumes or odors. Safe for classroom or studio.

NUMBER	SIZE	EACH	12/EA	24/EA
A05702-1001	1 oz Preserver	\$5.89	\$5.30	\$5.03
A05702-1004	2-5/8 oz Cake	8.98	8.08	7.67
A05702-1007	24 oz Tub	32.67	29.40	27.93

B The Masters® Artist's Hand Soap
Specially formulated to remove any petroleum-based paint or product without harsh and messy thinners, this hand soap even removes dried-on paint with just water. The non-abrasive, environmentally safe formula leaves hands soft. 4.5 oz bar.

NUMBER	EACH	12/EA	36/EA
A04904-0000	\$5.20	\$4.68	\$4.45

C The Masters® & Kiss-Off™ Classroom Cleanup Pack
This is a great combo pack for removing paints, stains, dyes, and more when you're involved in art projects, crafts, hobbies, and decorative painting. The kit contains six Kiss-Off stain remover sticks in 0.7 oz propel-repel tubes, and 24 blocks of non-toxic The Masters hand soap in a convenient 1.4 oz size.

NUMBER	EACH	6/EA
A06987-1030	\$90.13	\$81.11

D Kiss-Off™ Stain Remover
The on-the-spot stain remover! Keep one at home, one in the car, and one at the office. A must for travel, Kiss-Off takes out oil paint (wet or dry), makeup, wine, blood, grass stains, grease, copy machine stains, and "mystery spots." 0.7 oz propel-repel tube.

NUMBER	EACH	12/EA	24/EA
A04906-0000	\$4.99	\$4.50	\$4.27



E Weber® Turpenoid Natural
Made from organic ingredients, this revolutionary brush cleaner and conditioner provides a healthier, safer alternative to traditional solvents. Non-toxic and non-flammable. Note: Weber Turpenoid Natural cannot be shipped to Colorado or Rhode Island.

NUMBER	SIZE	EACH	3/EA
A00443-1005	8 oz (237 ml)	\$10.87	\$9.78
A00443-1006	Pint (473 ml)	16.60	14.94
A00443-1007	Quart (946 ml)	22.48	20.23

F Da Vinci® All Natural Brush Soap with Conditioner
Help your brushes last longer by cleaning and conditioning them properly. This all-natural, chemical-free, vegetable-based soap contains a conditioning agent created by brush makers that keeps both the natural hair and synthetic fibers in your brushes smooth and elastic.

NUMBER	EACH	5/EA
A05729-1001	\$10.03	\$9.03

G Winsor & Newton™ Brush Cleaner and Restorer
For use on natural or synthetic brushes. Completely cleans dried acrylics, oils, and alkyds with no damage to the brush head or loss of fibers. Effective within minutes for oil colors (hours for dried acrylics). Leaves no oil residue. This water-soluble cleaner is non-toxic, biodegradable, non-flammable, and has low vapor. Plastic bottle.

NUMBER	SIZE	EACH	6/EA
A05706-1004	4 oz (118 ml)	\$6.81	\$6.13
A05706-1016	16 oz (473 ml)	18.69	16.83
A05706-1032	32-oz (946-ml)	33.13	29.83



H Pink Soap™ Artist Brush Cleaner
After cleaning brushes in solvent, work a little Pink Soap into the bristles of the brush, and rinse. Repeat this until the soap stays pink. You can then be sure that your brush is clean and safe to put away. Use Pink Soap with all types of paint.

NUMBER	SIZE	EACH	12/EA
A05704-3054	4 oz	\$3.77	\$3.39
A05704-3050	8 oz	5.71	5.14
A05704-9009	Gallon	100.98	90.88

I Mona Lisa™ Brush Shaper™
Prolong the life of natural and synthetic brushes with a product that stiffens and re-shapes bristles without harming the brush or the environment. Simply dip your brush into this non-toxic sizing after all paint has been removed, and work it into the bristles. Use your fingers to shape the brush head into its original form and set the brush aside to dry. Before your next painting session, rinse the bristles with water or briskly move them back and forth before using the brush. 2 oz jar.

NUMBER	EACH	12/EA
A05717-1002	\$5.07	\$4.56

J EZ Air™ 3-In-One Cleaners
Developed to be as kind to the environment as they are to artists, EZ Air 3-In-One Cleaners were created in cooperation with professional artisans and crafters to be environmentally safe, and to minimize exposure to harmful solvents. Available in two formulations, each cleaner was developed to be used for three very specific purposes. For more details, visit DickBlick.com.

Acrylic Brush/Airbrush/Studio Cleaner

NUMBER	SIZE	EACH	12/EA
A05737-1005	8 oz	\$7.05	\$6.34
A05737-1006	16 oz	8.82	7.93

Oil Brush/Silkscreen/Intense Cleaner

NUMBER	SIZE	EACH	12/EA
A05737-1105	8 oz	\$13.23	\$11.90
A05737-1106	16 oz	16.76	15.07

K EZ Air™ Brush & Hand Wipes
These pre-moistened 5" x 8" wipes contain jojoba oil, Vitamin E, aloe vera, and other emollients to gently remove paint from hands, brushes, and equipment. Package of 70 wipes.

NUMBER	EACH	6/EA
A05724-1001	\$8.55	\$7.69



L-N Marvelous Marianne's Savvy Soap® Cleaners and SkinSafer Barrier Cream
An environmentally friendly cleaner that safely removes oil and acrylic paints, ink, and pastels from brushes and hands. It restores bristles even on hardened brushes and is safe for use with art and craft materials. The eco-friendly, skin-safe formula contains corn and/or cottonseed oil/soybean oil, aloe, glycerin, and lanolin. It's biodegradable and non-toxic — and it smells great!

NUMBER	SIZE	EACH	12/EA
A04818-1006	L 16 oz (473 mL)	\$14.09	\$12.68
A04818-1009	M Gallon (3.78 Liter)	50.95	45.85

SkinSafer Barrier Cream — This greaseless, botanically based, peppermint-scented cream forms a matte coating to help protect skin from ink, paints, and other "creative grime," as well as outside irritants like poison ivy and oak.

NUMBER	SIZE	EACH	12/EA
A05726-1006	N 16 oz (473 ml)	\$26.53	\$23.88

O Holbein® Duo Aqua Brush Cleaner
This non-flammable, odorless cleaning solution was specially formulated for use with Holbein Duo Aqua Water Soluble Oils, but it's also great for use with other water-soluble oil colors. This mild cleaner also keeps brushes in shape by adding extra protection to the bristles. It also works well with acrylic and watercolor paints, and can even be used with traditional oils; however, the brushes should be allowed to dry completely after being cleaned before they are used again.

NUMBER	SIZE	EACH	6/EA
A05730-1004	200 ml	\$7.63	\$6.87
A05730-1005	500 ml	14.50	13.05



P Richeson® Studio Soap
This versatile linseed oil soap is an excellent brush cleaner and moisturizer that can also be used to clean your hands. Minimal odor makes it ideal for classroom or studio settings.

NUMBER	SIZE	EACH	12/EA
A05727-1004	4 oz (120 ml)	\$7.18	\$6.45
A05727-1085	8.5 oz (251 ml)	11.52	10.36

Q Simple Green Cleaner
You'll find hundreds of uses for this environmentally friendly, versatile cleaner — dilute it as needed to remove oil, grease, ink, and paint from washable surfaces, including parts, palettes, and printing plates. Biodegradable, non-toxic, non-abrasive, non-ionic, and non-flammable. One gallon (3.78 Liter).

NUMBER	EACH	6/EA
A04989-1009	\$26.16	\$23.53

R Tub O'Towels® Multi-Purpose Wipes
These extra-large 10" x 12" scrubbing towels have twice the cleaning surface of typical wipes. Great for removing ink, permanent marker, paint, wax, adhesive, glue, urethanes, epoxy, tape, and more, they have a tough fiber weave that withstands vigorous scrubbing. The serious solution of nine cleaning agents also contains lanolin, aloe vera, and Vitamin E, so it's kind to your hands, too. No VOCs, 100% biodegradable, with a pleasant citrus fragrance.

NUMBER	DESCRIPTION	EACH	12/EA
A07235-1040	40 Count	\$8.53	\$7.68
A07235-1090	90 Count	20.70	18.63

S Gojo® Fast Wipes® Towels
No water? No problem! These handy disposable towels are designed to get rid of oils and light grease fast. Pack of 60 wipes fits in your backpack or toolkit.

NUMBER	DESCRIPTION	EACH	6/EA
A02979-1001	60-ct Pack	\$22.25	\$19.99



T Gojo® Waterless Orange Cleaner
Gojo is the natural, economical way to remove artistic soils, dirt, and grease with or without water. Quick acting for ground-in dirt. USDA E4 Classification. Gallon (3.78 liter).

NUMBER	DESCRIPTION	EACH	4/EA
A02980-1009	Smooth	\$36.65	\$32.99
A02980-1019	Pumice	36.65	32.99

U 1 Shot® Brush Cleaner
A premium product for conditioning, cleaning, and storing brushes, 1 Shot is also excellent for reconditioning, softening, and renewing hardened bristles on natural and nylon brushes.

NUMBER	SIZE	EACH	6/EA
A05731-1007	Quart (946 ml)	\$19.25	\$17.33

V Bristle Magic™ Brush Cleaner
Bristle Magic is a cleaner and reconditioner that uses recycled ingredients to remove oil and acrylic paints from paintbrushes. It even removes dried-on paints. An environmentally friendly product, Bristle Magic is non-toxic, non-flammable, biodegradable, and reusable. What's more, it doesn't produce fumes or hazardous vapors!

NUMBER	SIZE	EACH	6/EA
A05733-1004	4 oz	\$6.97	\$6.28
A05733-1005	8 oz	11.81	10.63
A05733-1007	32 oz	25.78	23.20
A05733-1009	127 oz	69.85	62.87

W Masterson® Fresh Water Rinse Well
Keep fresh water at your fingertips without multiple rinse containers or inconvenient trips to the sink! This well consists of a 28 oz (840 ml) plastic water bottle, a durable plastic base with a well in the center for brush cleaning, and a reservoir to hold the used water. Press the button at the front and the Rinse Well drains the used water and automatically refills the well with a clean supply. Use with water media only. The spare bottle is for transporting water. It features a closed lid rather than a spouted lid.

NUMBER	DESCRIPTION	EACH	6/EA
A06910-0000	Fresh Water Rinse Well	\$19.61	\$17.65
A06910-0010	Spare Bottle	5.63	5.06

HEALTH & SAFETY ICONS: ●=CL / ■=Prop 65 / ▼=CL & Prop 65
See page 644 for more information.

WARNING! Products marked with a Prop 65 symbol (■ or ▼) can expose you to chemicals, including cadmium, which are known to the State of California to cause cancer and birth defects or other reproductive harm. For more information, visit P65Warnings.ca.gov.

BLICK® cotton canvas



A Blick® Academic Cotton Canvas 2-Packs

A good quality, economical option for students. 4 oz cotton canvas is triple-coated with acrylic gesso for a primed weight of 9 oz. The 5/8" profile stretcher bars are made of solid wood. Back-stapled. Sold in packs of two.

NUMBER	SIZE	EACH	10/EA
A07167-0066	6" x 6"	\$5.59	\$5.03
A07167-0810	8" x 10"	9.06	8.15
A07167-0912	9" x 12"	10.04	9.04
A07167-1114	11" x 14"	12.03	10.83
A07167-1212	12" x 12"	11.80	10.62
A07167-1620	16" x 20"	18.45	16.60
A07167-2024	20" x 24"	25.78	23.20

B Canvas Bulk Pack of 40

Perfect for classrooms, painting parties, or experimenting, these affordable, ready-to-paint canvases are pre-primed with acrylic gesso. The lightweight cotton canvas is stretched on a 5/8" profile wooden frame. 16" x 20" canvases.

NUMBER	SIZE	EACH	3/EA
A07031-1008	16" x 20"	\$202.75	\$182.49

Blick® Super Value Canvas Packs

Easy on classroom budgets and available in many popular sizes, these packs feature 4 oz pure cotton duck canvas stretched on a 5/8" profile kiln-dried wood frame. Primed with three coats of acid-free gesso, they're ready to paint with oils or acrylics. Primed weight is 8 oz. Great for pairing with Blick Super Value Floater Frames!

NUMBER	SIZE	PKG	EACH	10/EA	20/EA
A07526-1088	8" x 8"	12	\$25.35	\$20.99	\$18.99
A07526-1810	8" x 10"	10	25.35	20.99	18.99
A07526-1912	9" x 12"	8	25.35	20.99	18.99
A07526-1114	11" x 14"	7	25.35	20.99	18.99
A07526-1212	12" x 12"	7	25.35	20.99	18.99
A07526-1216	12" x 16"	6	25.35	20.99	18.99
A07526-1418	14" x 18"	6	25.35	20.99	18.99
A07526-1620	16" x 20"	5	25.35	20.99	18.99

See page 241 for Blick Super Value Floater Frames — specially designed for our Super Value Canvas!

C Blick® Studio Mini Canvases, Canvas Panels, and Easel

Well made and economical, Blick Studio Mini Canvases and Canvas Panels are primed and ready to paint — perfect for quick studies, miniatures, multiples, crafts, and gifts. Their acid-free, archival surface is ideal for oils, acrylics, tempera, and mixed media. Display your finished work on our wooden mini easel.

Canvas						
NUMBER	SIZE	PKG	COLOR	EACH	10/EA	50/EA
A07197-2402	2" x 2"	6	Black	\$7.19	\$6.47	\$6.14
A07197-2424	2" x 4"	4	Black	7.19	6.47	6.14
A07197-2403	3" x 3"	4	Black	7.19	6.47	6.14
A07197-2244	4" x 4"	2	Black	7.19	6.47	6.14
A07197-1402	2" x 2"	6	White	7.19	6.47	6.14
A07197-1424	2" x 4"	4	White	7.19	6.47	6.14
A07197-1403	3" x 3"	4	White	7.19	6.47	6.14
A07197-1244	4" x 4"	2	White	7.19	6.47	6.14

Panels						
NUMBER	SIZE	PKG	COLOR	EACH	10/EA	50/EA
A07197-2802	2" x 2"	8	Black	\$7.19	\$6.47	\$6.14
A07197-2624	2" x 4"	6	Black	7.19	6.47	6.14
A07197-2603	3" x 3"	6	Black	7.19	6.47	6.14
A07197-2444	4" x 4"	4	Black	7.19	6.47	6.14
A07197-1802	2" x 2"	8	White	7.19	6.47	6.14
A07197-1624	2" x 4"	6	White	7.19	6.47	6.14
A07197-1603	3" x 3"	6	White	7.19	6.47	6.14
A07197-1444	4" x 4"	4	White	7.19	6.47	6.14

Mini Easel			
NUMBER	SIZE	EACH	10/EA
A50360-1001	3" x 5"	\$2.20	\$1.98

Blick® Studio Black Cotton Canvas

Great for paintings with deeper color palettes. Medium texture, 7 oz cotton canvas is primed with three coats of acid-free black gesso for a primed weight of approximately 10.5 oz. Stretched by hand and back-stapled on 3/4" profile solid wood stretchers for a clean, paintable edge.

NUMBER	SIZE	EACH	6/EA
A07192-2012	8" x 10"	\$11.07	\$8.86
A07192-2005	11" x 14"	15.08	12.06
A07192-2008	16" x 20"	23.24	18.59
A07192-2009	18" x 24"	30.53	24.42
A07192-2001	20" x 24"	28.58	22.86

canvas bracing styles

Back bracing may vary by style and size.

Canvas sizes with no back bracing are:

4" x 4"	8" x 8"	11" x 14"
4" x 6"	8" x 10"	12" x 12"
6" x 6"	9" x 12"	12" x 16"
6" x 8"	10" x 10"	16" x 20"
6" x 12"	10" x 20"	18" x 18"
		20" x 20"

Canvas sizes with this type of back bracing are:

8" x 24"	18" x 24"	22" x 28"
10" x 30"	18" x 36"	24" x 24"
12" x 36"	20" x 24"	24" x 30"
		24" x 36"

Canvas sizes with this type of back bracing are:

30" x 40"	48" x 48"
36" x 36"	30" x 48"
30" x 30"	

Canvas sizes with this type of back bracing are:

36" x 48"	40" x 60"
48" x 60"	60" x 72"
36" x 72"	36" x 60"
	48" x 72"



Blick® Studio Cotton Canvas — Museum 2-3/8" Profile

NUMBER	SIZE	EACH	10/EA	20/EA
A07137-2005	11" x 14"	\$21.69	\$16.27	\$14.64
A07137-2004	12" x 12"	20.95	15.71	14.14
A07137-1418	14" x 18"	19.99	14.99	13.49
A07137-2008	16" x 20"	29.95	22.47	20.22
A07137-2019	18" x 24"	33.32	24.99	22.49
A07137-2024	24" x 24"	44.19	33.14	29.83
A07137-2030	24" x 30"	49.98	37.48	33.73
A07137-2015	24" x 36"	58.51	43.88	39.49
A07137-2026	30" x 40"	75.95	56.96	51.26
A07137-0636	36" x 36"	131.78	98.83	88.95
A07137-0648	36" x 48"	156.31	117.23	105.50

XL Sizes Truck Shipment. See page 648 for details.

NUMBER	SIZE	PKG	EACH
A07137-4848	48" x 48"	3	\$285.59
A07137-4860	48" x 60"	3	319.00
A07137-4872	48" x 72"	3	366.00
A07137-6072	60" x 72"	3	431.00

Blick® Studio Cotton Canvas — Gallery 1-3/8" Profile

NUMBER	SIZE	EACH	10/EA	20/EA
A07121-0000	4" x 4"	\$9.90	\$7.42	\$6.68
A07121-0064	4" x 6"	10.51	7.88	7.09
A07121-1000	6" x 6"	12.35	9.26	8.33
A07121-0068	6" x 8"	13.11	9.83	8.85
A07121-1001	6" x 12"	14.46	10.85	9.76
A07121-0088	8" x 8"	13.56	10.17	9.15
A07121-1002	8" x 10"	14.91	11.18	10.06
A07121-0824	8" x 24"	23.34	17.50	15.75
A07121-1003	9" x 12"	17.54	13.15	11.84
A07121-1009	10" x 10"	16.44	12.33	11.09
A07121-1007	10" x 20"	27.63	20.73	18.65
A07121-1130	10" x 30"	30.19	22.65	20.38
A07121-1005	11" x 14"	22.07	16.55	14.89
A07121-1004	12" x 12"	20.15	15.11	13.59
A07121-1006	12" x 16"	24.30	18.23	16.40
A07121-1023	12" x 36"	32.32	24.25	21.82
A07121-1008	16" x 20"	29.16	21.87	19.68
A07121-1018	18" x 18"	31.15	23.36	20.99
A07121-1019	18" x 24"	32.08	24.06	21.65
A07121-1836	18" x 36"	40.32	30.24	27.22
A07121-1013	20" x 20"	31.28	23.46	21.11
A07121-1011	20" x 24"	32.48	24.36	21.92
A07121-1012	22" x 28"	37.78	28.33	25.50
A07121-1024	24" x 24"	36.78	27.58	24.83
A07121-1030	24" x 30"	43.43	32.57	29.31
A07121-1015	24" x 36"	48.72	36.54	32.88
A07121-0030	30" x 30"	46.55	34.91	31.42
A07121-1026	30" x 40"	53.65	40.23	36.21
A07121-0048	30" x 48"	74.79	56.09	50.48
A07121-0636	36" x 36"	72.45	54.34	48.91
A07121-1036	36" x 48"	88.05	66.03	59.43

XL Sizes Truck Shipment. See page 648 for details.

NUMBER	SIZE	PKG	EACH	2/EA
A07121-3660	36" x 60"	5	\$390.00	\$312.00
A07121-3672	36" x 72"	5	504.00	404.00
A07121-9060	40" x 60"	5	396.00	317.00
A07121-9048	48" x 48"	5	395.00	316.00
A07121-9072	48" x 72"	5	540.00	432.00

PRODUCT REVIEWS are a great way to share your opinions with others as well as find the products that best meet your needs!



To learn more, visit DickBlick.com/productinfo/reviews

BEST seller!

BLICK® STUDIO cotton canvas features:

- Designed for versatile styles and techniques in oil or acrylic
- Triple-primed with standard gesso
- 10.5 oz primed weight (7 oz pre-primed)
- Back-stapled

10.5 oz primed



100% Cotton Canvas
10.5 oz primed weight (7 oz pre-primed)

Blick® Studio Cotton Canvas — Traditional 3/4" Profile

NUMBER	SIZE	EACH	10/EA	20/EA
A07135-2044	4" x 4"	\$3.13	\$2.34	\$2.11
A07135-2046	4" x 6"	3.43	2.57	2.31
A07135-2000	6" x 6"	3.87	2.90	2.61
A07135-2068	6" x 8"	4.43	3.32	2.99
A07135-2001	6" x 12"	4.99	3.74	3.37
A07135-2088	8" x 8"	4.70	3.53	3.17
A07135-2002	8" x 10"	5.17	3.87	3.49
A07135-2014	8" x 24"	10.39	7.79	6.99
A07135-2003	9" x 12"	5.85	4.39	3.95
A07135-2009	10" x 10"	5.54	4.15	3.74
A07135-2007	10" x 20"	10.46	7.85	7.06
A07135-2017	10" x 30"	12.35	9.26	8.33
A07135-2005	11" x 14"	8.05	6.03	5.43
A07135-2004	12" x 12"	7.73	5.80	5.22
A07135-2006	12" x 16"	8.57	6.43	5.79
A07135-2016	12" x 36"	15.27	11.45	10.30
A07135-1418	14" x 18"	11.25	8.43	7.59
A07135-2008	16" x 20"	12.42	9.31	8.38
A07135-2018	18" x 18"	12.63	9.47	8.52
A07135-2019	18" x 24"	15.71	11.78	10.60
A07135-1836	18" x 36"	22.31	16.73	15.05
A07135-2013	20" x 20"	14.34	10.75	9.68
A07135-2011	20" x 24"	16.07	12.05	10.85
A07135-2012	22" x 28"	20.35	15.26	13.73
A07135-2024	24" x 24"	19.94	14.95	13.46
A07135-2030	24" x 30"	22.71	17.03	15.33
A07135-2015	24" x 36"	25.84	19.38	17.44
A07135-3030	30" x 30"	27.84	20.88	18.79
A07135-3036	36" x 36"	38.35	28.76	25.88

BLICK® STUDIO

Belgian linen canvas



features:

- The luxury of linen at an affordable Blick price
- Suitable for oils or acrylics
- Triple-primed with standard gesso
- 9 oz primed weight (6 oz pre-primed)
- Back-stapled

9 oz primed

Primed
Shown Actual Size

Pre-Primed
Shown Actual Size

9 oz primed weight
(6 oz pre-primed)

3/4"

1-1/2"



BLICK canvas at a glance

Type	Perfect for	Primed Weight
ACADEMIC	Students	4 oz
STUDIO COTTON	Students & Hobbyists	10.5 oz
STUDIO BELGIAN LINEN	Students & Professionals	9 oz
PREMIER COTTON	Students & Professionals	15 oz
PREMIER BELGIAN LINEN	Professionals	10 oz
PREMIER HEAVYWEIGHT	Professionals	20 oz

Blick® Studio Belgian Linen Canvas — 3/4" Profile

NUMBER	SIZE	EACH	6/EA	12/EA
A07166-0057	5" x 7"	\$8.51	\$6.81	\$6.13
A07166-0066	6" x 6"	8.92	7.13	6.42
A07166-0068	6" x 8"	9.37	7.49	6.75
A07166-0088	8" x 8"	9.83	7.87	7.08
A07166-0612	6" x 12"	12.05	9.64	8.67
A07166-0810	8" x 10"	13.37	10.69	9.63
A07166-0912	9" x 12"	16.59	13.27	11.94
A07166-1010	10" x 10"	15.67	12.53	11.28
A07166-1020	10" x 20"	22.03	17.63	15.87
A07166-1030	10" x 30"	31.93	25.54	22.99
A07166-1114	11" x 14"	20.12	16.10	14.49
A07166-1212	12" x 12"	17.06	13.65	12.86
A07166-1216	12" x 16"	21.10	16.88	15.19
A07166-1236	12" x 36"	39.54	31.63	28.47
A07166-1620	16" x 20"	31.59	25.27	22.74
A07166-1818	18" x 18"	32.57	26.05	23.45
A07166-1824	18" x 24"	40.28	32.22	28.99
A07166-2020	20" x 20"	36.78	29.43	26.48
A07166-2024	20" x 24"	39.88	31.90	28.71
A07166-2030	20" x 30"	53.39	42.71	38.44
A07166-2228	22" x 28"	54.45	43.56	39.20
A07166-2424	24" x 24"	41.91	33.53	30.18
A07166-2430	24" x 30"	55.99	44.79	40.31
A07166-2436	24" x 36"	59.21	47.37	42.63
A07166-2448	24" x 48"	71.66	57.33	51.60
A07166-3030	30" x 30"	61.51	49.21	44.28
A07166-3140	30" x 40"	74.50	59.61	53.64
A07166-3736	36" x 36"	79.33	63.47	57.12
A07166-3748	36" x 48"	96.58	77.27	69.54

Blick® Studio Belgian Linen Canvas — 1-1/2" Profile

NUMBER	SIZE	EACH	3/EA	6/EA
A07174-0066	6" x 6"	\$16.76	\$13.41	\$12.07
A07174-0088	8" x 8"	21.25	16.99	15.29
A07174-0810	8" x 10"	23.25	18.61	16.75
A07174-0912	9" x 12"	26.86	21.49	19.34
A07174-1010	10" x 10"	25.90	20.72	18.65
A07174-1114	11" x 14"	31.87	25.49	22.95
A07174-1212	12" x 12"	30.58	24.46	21.99
A07174-1216	12" x 16"	35.82	28.66	25.79
A07174-1418	14" x 18"	41.53	33.23	29.90
A07174-1620	16" x 20"	51.85	41.48	37.33
A07174-1818	18" x 18"	52.03	41.63	37.46
A07174-1824	18" x 24"	61.50	49.20	44.28
A07174-1836	18" x 36"	84.48	67.58	60.83
A07174-2020	20" x 20"	59.85	47.88	43.09
A07174-2024	20" x 24"	66.81	53.44	48.10
A07174-2030	20" x 30"	76.83	61.46	55.32
A07174-2040	20" x 40"	87.78	70.23	63.20
A07174-2160	20" x 60"	133.37	106.69	96.03
A07174-2228	22" x 28"	77.51	61.99	55.79
A07174-2430	24" x 30"	77.26	61.81	55.63
A07174-2436	24" x 36"	89.98	71.98	64.78
A07174-2448	24" x 48"	118.13	94.51	85.05
A07174-2572	24" x 72"	170.75	136.59	122.93
A07174-3130	30" x 30"	88.26	70.61	63.55
A07174-3136	30" x 36"	102.53	81.99	73.82
A07174-3140	30" x 40"	109.78	87.82	79.03
A07174-3160	30" x 60"	165.77	132.62	119.35
A07174-3736	36" x 36"	125.44	100.35	90.32
A07174-3748	36" x 48"	163.59	130.88	117.79

XL Sizes — *Does not qualify for free shipping offer.
Truck Shipment. See page 648 for details.

NUMBER	SIZE	PKG	EACH	3/EA
A07174-3672	*36" x 72"	5	\$852.00	\$681.00
A07174-3860	*38" x 60"	5	786.00	629.00
A07174-4872	*48" x 72"	5	1087.00	870.00

canvas panels



Blick® Studio Canvas Pads

An ideal plein air surface or sketch pad for students or professionals, these affordable pads contain 10 sheets of 5 oz, medium texture, triple acrylic-primed cotton canvas. Primed weight is 8 oz.

NUMBER	SIZE	EACH	12/EA
A07400-1043	9" x 12"	\$10.37	\$9.34
A07400-1046	12" x 16"	17.99	16.18
A07400-1048	16" x 20"	29.16	26.26
A07400-1049	18" x 24"	40.27	36.24

Blick® Premier Archival Canvas Panels

Manufactured using the highest-quality materials, Blick Premier Archival Panels are made to stand the test of time, offering a stable, archival, portable surface for your oil and acrylic paintings. Their tempered hardboard cores will not warp, become brittle, or degrade over time. Choose Belgian linen or heavyweight cotton.

Oil-Primed Belgian Linen —

Medium texture, 8 oz Belgian linen canvas, double oil-primed by hand to reach a 13 oz primed weight.

NUMBER	SIZE	EACH	12/EA
A07017-0057	5" x 7"	\$18.45	\$16.60
A07017-0068	6" x 8"	20.06	18.05
A07017-0810	8" x 10"	21.42	19.27
A07017-0816	8" x 16"	24.88	22.38
A07017-0912	9" x 12"	22.30	20.06
A07017-1114	11" x 14"	24.70	22.22
A07017-1216	12" x 16"	25.99	23.41
A07017-1620	16" x 20"	33.46	30.10
A07017-1824	18" x 24"	40.90	36.79

Acrylic-Primed

Belgian Linen — Medium texture, 8 oz Belgian linen canvas, double acrylic-primed to reach a 12 oz primed weight.

NUMBER	SIZE	EACH	12/EA
A07018-0066	6" x 6"	\$9.72	\$8.75
A07018-0068	6" x 8"	9.88	8.89
A07018-0810	8" x 10"	10.51	9.46
A07018-0816	8" x 16"	15.09	13.58
A07018-0912	9" x 12"	11.73	10.56
A07018-1114	11" x 14"	14.72	13.24
A07018-1216	12" x 16"	18.07	16.26

Blick® Studio Canvas Panels

Sturdy and warp-resistant, Blick Studio Canvas Panels are an incredible value. They're crafted from 5 oz 100% cotton and double-primed to our exacting standards. The acid-free core is made from a cellulose byproduct that's an ecologically renewable resource. Panels are 1/8" thick.

NUMBER	SIZE	EACH	36/EA
A07008-0044	4" x 4"	\$0.99	\$0.77
A07008-0045	4" x 5"	1.04	.81
A07008-0046	4" x 6"	1.20	.93
A07008-0048	4" x 8"	1.21	.94
A07008-0057	5" x 7"	1.41	1.10
A07008-0066	6" x 6"	1.51	1.18
A07008-0068	6" x 8"	1.54	1.23
A07008-0612	6" x 12"	1.95	1.56
A07008-0088	8" x 8"	1.70	1.34
A07008-0810	8" x 10"	1.98	1.58
A07008-0816	8" x 16"	2.92	2.33
A07008-0912	9" x 12"	2.45	1.96
A07008-1014	10" x 14"	2.69	2.15
A07008-1114	11" x 14"	2.95	2.35
A07008-1020	10" x 20"	4.40	3.53
A07008-1212	12" x 12"	3.43	2.75
A07008-1216	12" x 16"	3.93	3.15
A07008-1418	14" x 18"	4.83	3.85
A07008-1530	15" x 30"	9.23	7.29
A07008-1620	16" x 20"	6.91	5.49
A07008-1824	18" x 24"	8.53	6.75
A07008-2024	20" x 24"	9.19	7.30
A07008-2228	22" x 28"	9.90	7.90
A07008-2430	24" x 30"	12.45	9.92
A07008-2436	24" x 36"	14.27	11.35

Packs of 5

NUMBER	SIZE	PKG	EACH	6/EA
A07008-5045	4" x 5"	5	\$4.58	\$3.65
A07008-5046	4" x 6"	5	5.29	4.25
A07008-5057	5" x 7"	5	6.03	4.79
A07008-5066	6" x 6"	5	6.03	4.79
A07008-5068	6" x 8"	5	6.78	5.40
A07008-5088	8" x 8"	5	7.85	6.29
A07008-5810	8" x 10"	5	8.52	6.83
A07008-5912	9" x 12"	5	10.59	8.50
A07008-5114	11" x 14"	5	12.69	10.25
A07008-5112	12" x 12"	5	12.15	9.65
A07008-5216	12" x 16"	5	15.67	12.50
A07008-5418	14" x 18"	5	19.35	15.38
A07008-5620	16" x 20"	5	24.65	19.75
A07008-5824	18" x 24"	5	32.25	25.99
A07008-5024	20" x 24"	5	36.39	29.25



Universal-Primed Heavyweight Cotton —

Medium texture, 7 oz cotton canvas, double acrylic-primed to reach an 11 oz primed weight.

NUMBER	SIZE	EACH	12/EA
A07019-0066	6" x 6"	\$10.61	\$9.60
A07019-0068	6" x 8"	11.65	10.53
A07019-0088	8" x 8"	12.12	10.96
A07019-0810	8" x 10"	12.96	11.72
A07019-0816	8" x 16"	16.25	14.70
A07019-0912	9" x 12"	13.72	12.40
A07019-1114	11" x 14"	16.25	14.70
A07019-1212	12" x 12"	16.99	15.38
A07019-1216	12" x 16"	17.19	15.55
A07019-1620	16" x 20"	21.70	19.63
A07019-1824	18" x 24"	24.15	21.84

Blick® Economy 24-Piece Canvas Panel Packs

Perfect for all types of media including oils, acrylics, and tempera, these economical, portable packs are ideal for classroom settings. The toothy surface grips paint well with minimal absorption. Sides are turned under and securely glued. Choose from a variety of popular sizes. Sold in packs of 24.

NUMBER	SIZE	EACH	2/EA
A07015-1044	4" x 4"	\$5.83	\$4.95
A07015-1000	5" x 7"	12.74	10.83
A07015-1012	8" x 10"	26.42	23.78
A07015-1023	9" x 12"	41.37	35.15
A07015-1005	11" x 14"	53.38	45.36
A07015-1006	12" x 16"	65.65	55.80
A07015-1017	14" x 18"	82.97	70.52
A07015-1008	16" x 20"	110.95	94.27
A07015-1009	18" x 24"	144.31	122.66



WINSOR & NEWTON™ classic cotton canvas

- A versatile, medium texture surface for painting in oils and acrylics
- Made from the finest grade cloth and primed with a highly pigmented acrylic gesso
- Responds beautifully to every brushstroke
- Back-stapled to kiln-dried fir and paulownia wood stretcher bars
- Patented technology
- 12.3 oz primed weight (7 oz pre-primed)

Winsor & Newton™ Classic Cotton Canvas, Traditional

3/4" Profile		EACH	6/EA
NUMBER	SIZE		
A07062-1003	6" x 6"	\$6.59	\$5.93
A07062-1012	8" x 10"	7.89	7.10
A07062-1023	9" x 12"	9.75	8.78
A07062-1005	11" x 14"	11.44	10.30
A07062-1004	12" x 12"	12.57	11.31
A07062-1006	12" x 16"	14.09	12.68
A07062-1007	14" x 18"	15.39	13.85
A07062-1008	16" x 20"	18.03	16.24
A07062-1009	18" x 24"	22.83	20.55
A07062-1001	20" x 24"	24.52	22.07

Winsor & Newton™ Classic Cotton Canvas, Deep Edge

1-3/8" Profile		EACH	6/EA
NUMBER	SIZE		
A07063-1003	6" x 6"	\$7.09	\$6.38
A07063-1012	8" x 10"	11.23	10.10
A07063-1023	9" x 12"	12.80	11.52
A07063-1005	11" x 14"	15.72	14.15
A07063-1004	12" x 12"	17.07	15.36
A07063-1006	12" x 16"	18.87	16.98
A07063-1008	16" x 20"	22.82	20.53
A07063-1009	18" x 24"	28.53	25.67
A07063-1015	24" x 36"	49.87	44.87
A07063-1026	3" x 40"	64.24	57.81

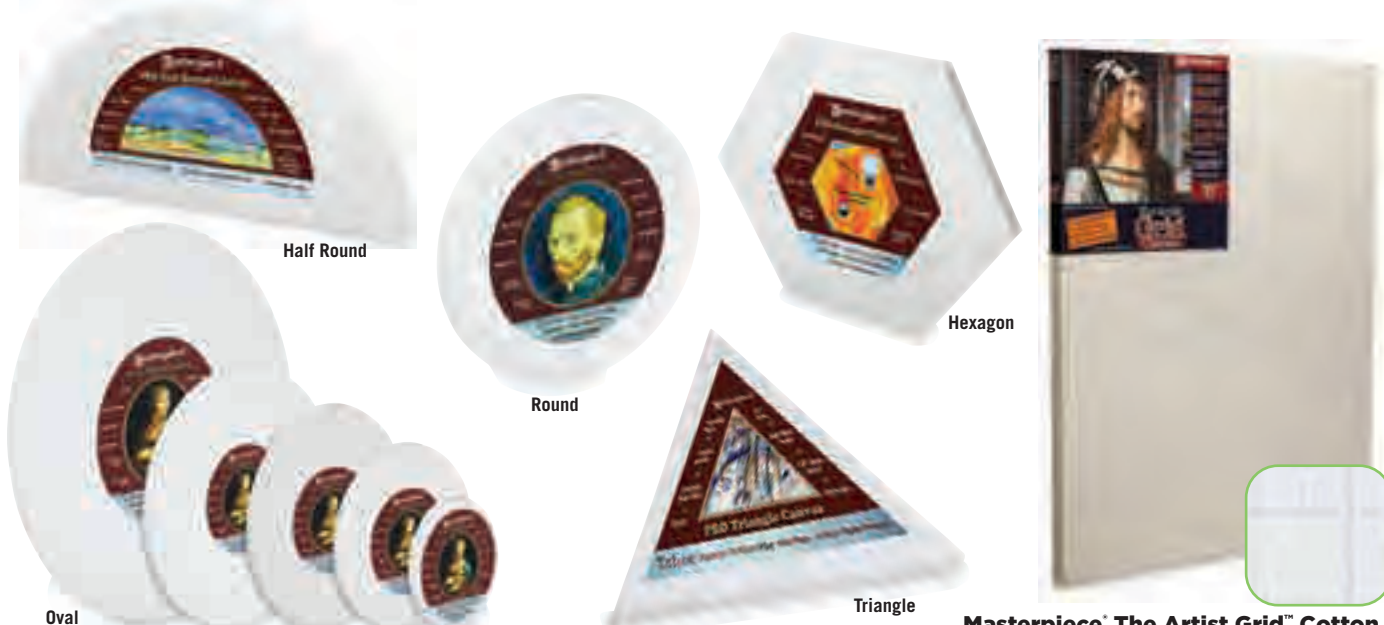

Masterpiece™ Tahoe Canvas Shapes

An archival-quality, acid-free painting surface with medium tooth and texture. 100% cotton canvas is triple-primed with acrylic gesso for a primed weight of 14.6 oz. Frame is solid MDF and features a 3/4" profile. A 1/4" relief to the canvas prevents frame impressions from marring the surface.

NUMBER	DESCRIPTION	SIZE	EACH	5/EA
A07050-0057	Oval	5" x 7"	\$13.34	\$11.99
A07050-0810	Oval	8" x 10"	19.25	17.32
A07050-1114	Oval	11" x 14"	27.11	24.40
A07050-1008	Round	8"	17.94	16.15
A07050-1010	Round	10"	24.03	21.63
A07050-1012	Round	12"	25.13	22.61

NUMBER	DESCRIPTION	SIZE	EACH	5/EA
A07050-2012	Half Round	6" x 12"	\$18.68	\$16.82
A07050-2016	Half Round	8" x 16"	27.86	25.07
A07050-2020	Half Round	10" x 20"	32.83	29.55
A07050-2024	Half Round	12" x 24"	38.80	34.92
A07050-2030	Half Round	15" x 30"	53.73	48.35
A07050-2036	Half Round	18" x 36"	74.62	67.16
A07050-2040	Half Round	20" x 40"	83.58	75.22
A07050-3010	Hexagon	10"	18.96	17.06
A07050-3014	Hexagon	14"	25.70	23.13
A07050-3017	Hexagon	17"	31.99	28.80
A07050-4065	Triangle	6 1/2"	12.25	10.99
A07050-4085	Triangle	8 1/2"	15.07	13.56
A07050-4010	Triangle	10"	19.90	17.91
A07050-4012	Triangle	12"	20.98	18.88
A07050-4017	Triangle	17"	31.99	28.80

Masterpiece™ The Artist Grid™ Cotton Canvas

This canvas is printed with blue grid lines so it's easier for artists to place objects from a photograph and plot landscapes, still lifes, and portraits. Made with 7 oz, 100% cotton canvas that's triple-primed for an archival, acid-free finish. Back-stapled. 3/4" profile.

NUMBER	SIZE	EACH	12/EA
A07155-0044	4" x 4"	\$6.53	\$5.87
A07155-0045	4" x 5"	6.67	5.99
A07155-0057	5" x 7"	9.11	8.20
A07155-1212	12" x 12"	15.19	13.67
A07155-1216	12" x 16"	16.69	14.99
A07155-1620	16" x 20"	21.82	19.63
A07155-1824	18" x 24"	27.62	24.85



Fredrix™ Blue Label Canvas

The ultra-smooth texture of this medium weight, blended polyflax/cotton canvas is great for capturing fine details in portraits. Triple acrylic-primed for use with oils or acrylics. Back-stapled.

3/4" Profile

NUMBER	SIZE	EACH	12/EA
A07105-1012	8" x 10"	\$7.34	\$6.24
A07105-1023	9" x 12"	8.74	7.43
A07105-1005	11" x 14"	10.15	8.62
A07105-1006	12" x 16"	12.08	10.26
A07105-1007	14" x 18"	13.49	11.46
A07105-1008	16" x 20"	14.89	12.65
A07105-1009	18" x 24"	19.29	16.39
A07105-1001	20" x 24"	20.83	17.70
A07105-1003	24" x 30"	26.30	22.35
A07105-1015	24" x 36"	31.58	26.83

1-3/8" Profile

NUMBER	SIZE	EACH	12/EA
A07703-1005	11" x 14"	\$17.55	\$14.91
A07703-1012	12" x 12"	17.26	14.67
A07703-1008	16" x 20"	23.87	20.29
A07703-1009	18" x 24"	29.05	24.69
A07703-1024	24" x 24"	36.24	30.80
A07703-1003	24" x 30"	41.99	35.69
A07703-1015	24" x 36"	47.60	40.46
A07703-1030	30" x 30"	48.32	41.07
A07703-1006	30" x 40"	59.25	50.36
A07703-1027	36" x 48"	73.06	62.09



Fredrix™ Paint It Yourself Classroom Mural Canvas

Developed by Fredrix Artist Canvas and the Wyland Foundation, the Paint It Yourself Classroom Mural Canvas uses art to teach young people about our forests and oceans and their importance to the world as irreplaceable resources. The 5 ft x 10 ft medium texture, 100% cotton canvas is primed and ready to use with acrylic, tempera, or oil paints. Grommets make it easy to display. Each canvas includes lesson plans designed by the marine artist and environmentalist Wyland.

NUMBER	COLOR	SIZE	EACH
A07348-1032	White	32" x 63"	\$52.38
A07348-1010	White	60" x 120"	85.95
A07368-2032	Black	32" x 60"	66.08
A07368-2060	Black	60" x 120"	98.47

Fredrix Mural Canvas Easels — Designed to support Fredrix Mural Canvas, but also great for any mural project. FOB Factory. See page 648 for details.

NUMBER	DESCRIPTION	EACH
AF50390-1040	Large, 73"H x 125"W x 6"D	\$288.50
A51759-1040	Mini, 73"H x 37"W x 6"D	223.25

FREDRIX™



Fredrix™ Metallic Stretched Canvas

This smooth, 13 oz poly/cotton canvas is triple primed with a specially formulated universal metallic gesso that offers a vibrant, luminous shimmer.

SIZE	GOLD	PEARLESCENT	EACH	12/EA
6" x 6"	A07080-9011	A07080-1121	\$11.74	\$9.98
6" x 12"	A07080-9012	A07080-1122	15.38	13.08
9" x 12"	A07080-9013	A07080-1123	16.59	14.11
12" x 12"	A07080-9014	A07080-1124	19.42	16.51
16" x 20"	A07080-9018	A07080-1128	25.09	21.33
18" x 24"	A07080-9019	A07080-1129	30.75	26.14
24" x 24"	A07080-9016	A07080-1126	34.80	29.59
24" x 36"	A07080-9015	A07080-1125	48.56	41.28



Fredrix™ Canvas Pads

The perfect surface for practicing or trying out new techniques. The 7 oz sheets (10 per pad) are coated with gesso.

NUMBER	SIZE	EACH	12/EA
A08908-1003	9" x 12"	\$8.25	\$7.42
A08908-1006	12" x 16"	13.61	12.25
A08908-1008	16" x 20"	24.79	22.31
A08908-1009	18" x 24"	30.91	27.80

Fredrix™ Black Canvas Pads

Excellent for paintings with deep color palettes as well as woodcut prints. Each pad contains 10 sheets of genuine 7 oz artist canvas, primed with black acrylic gesso and ready to paint.

NUMBER	SIZE	EACH	12/EA
A07403-2023	9" x 12"	\$8.60	\$7.74
A07403-2006	12" x 16"	14.89	13.40
A07403-2008	16" x 20"	24.11	21.70
A07403-2009	18" x 24"	32.99	29.71



Fredrix™ Value Series Cut Edge Canvas Panels

Super thin (less than 1/8") and lightweight, these artist-quality panels have clean, precision-cut edges. Primed and ready to paint, they're an inexpensive alternative to traditional canvas panels. Sold individually or in convenient multi-packs — perfect for classrooms!

Black

NUMBER	SIZE	PKG	EACH	12/EA
A07026-2023	4" x 6"	12	\$6.52	\$5.88
A07026-2003	4" x 6"	25	12.11	10.89
A07026-2020	5" x 7"	12	7.63	6.88
A07026-2000	5" x 7"	25	14.20	12.77
A07026-2068	8" x 8"	6	5.78	5.20
A07026-2008	8" x 8"	25	23.48	21.12
A07026-2062	8" x 10"	6	5.96	5.36
A07026-2022	8" x 10"	25	23.48	21.12
A07026-2063	9" x 12"	6	6.64	5.97
A07026-2123	9" x 12"	25	26.31	23.67
A07026-2065	11" x 14"	6	10.75	9.67
A07026-2025	11" x 14"	25	43.39	39.03
A07026-2061	12" x 12"	6	11.61	10.44
A07026-2012	12" x 12"	25	47.64	42.86
A07026-2066	12" x 16"	6	12.10	10.88
A07026-2028	12" x 16"	25	48.37	43.52

White

NUMBER	SIZE	PKG	EACH	12/EA
A07026-1023	4" x 6"	12	\$6.52	\$5.88
A07026-1003	4" x 6"	25	12.11	10.89
A07026-1020	5" x 7"	12	7.63	6.88
A07026-1000	5" x 7"	25	14.20	12.77
A07026-1068	8" x 8"	6	5.78	5.20
A07026-1008	8" x 8"	25	23.48	21.12
A07026-1062	8" x 10"	6	5.96	5.36
A07026-1022	8" x 10"	25	23.48	21.12
A07026-1063	9" x 12"	6	6.64	5.97
A07026-1223	9" x 12"	25	26.31	23.67
A07026-1065	11" x 14"	6	10.75	9.67
A07026-1025	11" x 14"	25	43.39	39.03
A07026-1061	12" x 12"	6	11.61	10.44
A07026-1012	12" x 12"	25	47.64	42.86
A07026-1066	12" x 16"	6	12.10	10.88
A07026-1028	12" x 16"	25	48.37	43.52



RICHESON®

Richeson® Cotton Art Panels

Each pH-neutral fiberboard panel is double-coated with gesso, creating an archival barrier between panel and canvas. Triple-coated with acrylic primer for an archival, acid-free, formaldehyde-free painting surface with excellent adhesive qualities and a soft tooth finish.

SIZE	EXTRA FINE	EACH	12/EA	FINE	EACH	12/EA	MEDIUM	EACH	12/EA
5" x 7"	A07068-1000	\$3.47	\$3.11	A07068-1100	\$3.47	\$3.11	A07068-1200	\$3.47	\$3.11
6" x 6"	A07068-1003	3.52	3.16	A07068-1103	3.52	3.16	A07068-1203	3.52	3.16
6" x 8"	A07068-1021	4.36	3.91	A07068-1121	4.36	3.91	A07068-1221	4.36	3.91
8" x 8"	A07068-1088	5.57	4.99	A07068-1188	5.57	4.99	A07068-1288	5.57	4.99
8" x 10"	A07068-1012	6.73	6.03	A07068-1112	6.73	6.03	A07068-1212	6.73	6.03
9" x 12"	A07068-1023	8.94	7.99	A07068-1123	8.94	7.99	A07068-1223	8.94	7.99
10" x 10"	A07068-1009	8.46	7.59	A07068-1109	8.46	7.59	A07068-1209	8.46	7.59
10" x 12"	A07068-1010	9.83	8.81	A07068-1110	9.83	8.81	A07068-1210	9.83	8.81
11" x 14"	A07068-1005	12.30	11.03	A07068-1105	12.30	11.03	A07068-1205	12.30	11.03
12" x 12"	A07068-1002	11.62	10.41	A07068-1102	11.62	10.41	A07068-1202	11.62	10.41
12" x 16"	A07068-1016	15.04	13.48	A07068-1116	15.04	13.48	A07068-1216	15.04	13.48
14" x 18"	A07068-1017	19.66	17.62	A07068-1117	19.66	17.62	A07068-1217	19.66	17.62
16" x 20"	A07068-1008	24.55	21.99	A07068-1108	24.55	21.99	A07068-1208	24.55	21.99
18" x 24"	A07068-1018	32.75	29.36	A07068-1118	32.75	29.36	A07068-1218	32.75	29.36
20" x 24"	A07068-1020	36.22	32.47	A07068-1120	36.22	32.47	A07068-1220	36.22	32.47

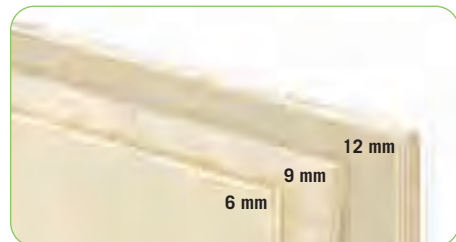

A-C Midwest Studio Birch Artist Panels

These high-quality, versatile mid-tone surfaces will make colors pop. Plies are cross-laminated to prevent warping. The panels aren't cradled. Unprimed.

A 6 mm				
NUMBER	SIZE	EACH	6/EA	
A13545-0612	6" x 12"	\$2.98	\$2.68	
A13545-0810	8" x 10"	5.42	4.88	
A13545-0912	9" x 12"	8.13	7.32	
A13545-1212	12" x 12"	10.84	9.76	
A13545-1224	12" x 24"	13.56	12.20	

B 9 mm				
NUMBER	SIZE	EACH	6/EA	
A13544-0612	6" x 12"	\$5.42	\$4.88	
A13544-0810	8" x 10"	8.13	7.32	
A13544-0912	9" x 12"	10.84	9.76	
A13544-1114	11" x 14"	16.26	14.64	
A13544-1212	12" x 12"	13.55	12.19	
A13544-1224	12" x 24"	18.97	17.08	
A13544-1620	16" x 20"	21.69	19.52	

C 12 mm				
NUMBER	SIZE	EACH	6/EA	
A13543-1114	11" x 14"	\$18.95	\$17.06	
A13543-1212	12" x 12"	16.24	14.62	
A13543-1224	12" x 24"	21.66	19.49	
A13543-1620	16" x 20"	24.37	21.94	

AMERICAN EASEL

D American Easel Wood Painting Panels

Manufactured in the USA from top-quality 1/8" birch plywood, sanded to render a smooth, firm painting surface. Cradled with a solid wood frame, these panels won't flex, stretch, or warp. Sanded edges assure a smooth transition from surface to sides. Hang flush to the wall with a single nail or screw — no frame needed!

Flat				
NUMBER	SIZE	EACH	6/EA	
A13606-1044	4" x 4"	\$6.36	\$5.73	
A13606-1055	5" x 5"	9.58	8.62	
A13606-1005	5" x 7"	9.99	8.99	
A13606-1006	6" x 6"	9.99	8.99	
A13606-1068	6" x 8"	16.50	14.84	
A13606-1008	8" x 8"	11.35	10.22	
A13606-1010	8" x 10"	12.39	11.14	
A13606-1316	8" x 16"	20.24	18.23	
A13606-1012	9" x 12"	14.44	12.99	
A13606-1110	10" x 10"	14.44	12.99	
A13606-1312	10" x 12"	18.07	16.27	
A13606-1007	10" x 20"	26.58	23.92	
A13606-1022	10" x 22"	23.73	21.35	
A13606-1014	11" x 14"	18.55	16.70	
A13606-1016	12" x 16"	20.63	18.56	
A13606-1018	12" x 18"	22.72	20.44	
A13606-1024	12" x 24"	27.84	25.05	
A13606-1114	14" x 14"	20.63	18.56	
A13606-1321	14-1/2" x 21-1/2"	26.58	23.92	
A13606-1116	16" x 16"	24.74	22.26	
A13606-1020	16" x 20"	27.84	25.05	
A13606-1112	12" x 12"	17.52	15.77	
A13606-1118	18" x 18"	28.89	25.99	
A13606-1124	18" x 24"	34.05	30.63	
A13606-1020	20" x 20"	27.84	25.05	
A13606-1224	20" x 24"	37.14	33.42	

Oval				
NUMBER	SIZE	EACH	6/EA	
A13606-1068	6" x 8"	\$16.50	\$14.84	

Round				
NUMBER	SIZE	EACH	6/EA	
A13606-3008	8" Diameter	\$17.52	\$15.76	

E American Easel Clear Gessoed Wood Panels

Retain the natural beauty of a woodgrain background while saving yourself hours of prep time in the studio. These panels are expertly primed with a clear ground that offers superior paint adhesion. They feature a 1/8" thick Baltic birch face and a smoothly sanded, solid poplar cradle with an impressive 1-5/8" profile.

NUMBER	SIZE	EACH	6/EA	
A14957-1000	5" x 7"	\$12.82	\$11.54	
A14957-1003	6" x 6"	12.82	11.54	
A14957-1021	6" x 8"	13.71	12.34	
A14957-1612	6" x 12"	15.57	13.99	
A14957-1088	8" x 8"	14.64	13.18	
A14957-1012	8" x 10"	16.46	14.81	
A14957-1023	9" x 12"	17.39	15.65	
A14957-1010	10" x 10"	18.28	16.45	
A14957-1005	11" x 14"	21.54	19.39	
A14957-1004	12" x 12"	22.47	20.23	
A14957-1006	12" x 24"	30.25	27.23	
A14957-1008	16" x 20"	32.57	29.32	
A14957-1009	18" x 24"	38.53	34.69	
A14957-1013	24" x 30"	60.49	54.44	
A14957-1015	24" x 36"	81.08	72.97	
A14957-1027	36" x 48"	134.40	120.96	

F American Easel Maple Panels

A wonderful panel for all mediums. Features a smoothly sanded maple face and back with three thicker poplar and cottonwood cores for excellent strength and stability. Keyholes on the reverse make it easy to hang with just a nail or screw. 1/2" profile.

NUMBER	SIZE	EACH	6/EA	
A07049-1044	4" x 4"	\$8.54	\$7.69	
A07049-1055	5" x 5"	8.87	7.98	
A07049-1057	5" x 7"	9.54	8.58	
A07049-1066	6" x 6"	9.20	8.28	
A07049-1068	6" x 8"	10.20	9.17	
A07049-1088	8" x 8"	11.13	9.99	
A07049-1810	8" x 10"	11.69	10.52	
A07049-1912	9" x 12"	14.76	13.28	
A07049-1010	10" x 10"	13.39	12.05	
A07049-1114	11" x 14"	18.73	16.86	
A07049-1212	12" x 12"	18.52	16.67	
A07049-1620	16" x 20"	34.07	30.66	
A07049-1824	18" x 24"	43.50	39.14	



BLICK SHIPS QUICK —
our reputation for industry-leading shipping times means you'll have it fast!

Hardboard Panels

Multifunctional panels can be used as a painting surface, mixing palette, drawing board, or for taping down watercolor paper. 1/8" thick hardboard.

NUMBER	SIZE	EACH	12/EA	
A14945-1066	6" x 6"	\$1.76	\$1.69	
A14945-1023	9" x 12"	1.33	1.21	
A14945-1005	11" x 14"	1.99	1.81	
A14945-1017	14" x 18"	2.65	2.41	
A14945-1008	16" x 20"	3.19	2.90	
A14945-1009	18" x 24"	4.20	3.82	
A14945-1001	20" x 24"	4.49	4.08	
A14945-1013	24" x 30"	7.04	6.41	

Baltic Birch Panels

These panels are popular with artists because of their firm, smoothly sanded surface, neutral color, strength, and affordability.

1/8" Thick				
NUMBER	SIZE	PKG	EACH	12/EA
A13614-1057	5" x 7"	5	\$8.28	\$7.45
A13614-0066	6" x 6"	5	7.67	6.91
A13614-0088	8" x 8"	5	10.37	9.33
A13614-0810	8" x 10"	5	11.80	10.62
A13614-0912	9" x 12"	5	17.86	16.08
A13614-1010	10" x 10"	5	15.66	14.09
A13614-1114	11" x 14"	5	23.36	21.03
A13614-1212	12" x 12"	5	24.15	21.73
A13614-1216	12" x 16"	5	27.51	24.76

1/4" Thick				
NUMBER	SIZE	PKG	EACH	12/EA
A13614-1620	16" x 20"	2	\$29.12	\$26.21
A13614-1824	18" x 24"	2	38.36	34.53

HEALTH & SAFETY ICONS: ●=CL / ■=Prop 65 / ▼=CL & Prop 65
See page 644 for more information.

WARNING! Products marked with a Prop 65 symbol (■ or ▼) can expose you to chemicals, including cadmium, which are known to the State of California to cause cancer and birth defects or other reproductive harm. For more information, visit P65Warnings.ca.gov.

AMPERSAND™ value series

Value Series Artist Panels are crafted specifically for students, hobbyists, and budget-minded artists. Now everyone can enjoy Ampersand quality at an affordable price!

See page 242 for Ampersand Floater Frames.



Ampersand™ Value Series Artist Panels — Unprimed Basswood

This panel is handcrafted using a thick, non-flexible basswood top, sanded perfectly smooth. It's ready to seal and prime with the ground of your choice. The fine, uniform characteristics of basswood offer a better, imperfection-free surface. Thick and durable, this panel gives you superior stability. It won't flex, even with heavy paint and wax layers. The cradle is crafted from solid pine that can be finished with paint or stain.

7/8" Cradled Panels			
NUMBER	SIZE	EACH	12/EA
A08948-1044	4" x 4"	\$9.64	\$8.68
A08948-1046	4" x 6"	11.07	9.96
A08948-1055	5" x 5"	11.80	10.61
A08948-1057	5" x 7"	12.51	11.26
A08948-1066	6" x 6"	12.75	11.47
A08948-1612	6" x 12"	17.29	15.55
A08948-1088	8" x 8"	15.97	14.37
A08948-1810	8" x 10"	17.99	16.19
A08948-1912	9" x 12"	19.99	18.79
A08948-1010	10" x 10"	19.30	17.36
A08948-1114	11" x 14"	25.62	23.06
A08948-1212	12" x 12"	24.92	22.42
A08948-1216	12" x 16"	30.41	27.36
A08948-1616	16" x 16"	35.89	32.29
A08948-1620	16" x 20"	44.24	39.81
A08948-1818	18" x 18"	44.60	40.14
A08948-1824	18" x 24"	52.47	47.22

1-1/2" Cradled Panels			
NUMBER	SIZE	EACH	12/EA
A08948-2044	4" x 4"	\$10.48	\$9.43
A08948-2055	5" x 5"	12.14	10.93
A08948-2057	5" x 7"	13.35	11.99
A08948-2066	6" x 6"	13.82	12.43
A08948-2612	6" x 12"	18.72	16.84
A08948-2088	8" x 8"	16.57	14.91
A08948-2810	8" x 10"	19.30	17.36
A08948-2816	8" x 16"	25.04	22.54
A08948-2912	9" x 12"	22.16	19.94
A08948-2110	10" x 10"	21.45	19.30
A08948-2114	11" x 14"	27.66	24.88
A08948-2120	10" x 20"	34.09	30.68
A08948-2212	12" x 12"	27.05	24.34
A08948-2216	12" x 16"	33.14	29.82
A08948-2224	12" x 24"	43.04	38.74
A08948-2236	12" x 36"	56.88	51.18
A08948-2418	14" x 18"	39.71	35.73
A08948-2616	16" x 16"	40.06	36.05
A08948-2620	16" x 20"	45.54	40.99
A08948-2818	18" x 18"	46.03	41.43
A08948-2824	18" x 24"	55.22	49.69
A08948-2220	20" x 20"	52.82	47.53

Ampersand™ Value Series Artist Panels — Primed Canvas Texture

A great introduction to panel painting, this ready-to-use panel features a 1/8" (3 mm) MDF surface coated with premium acrylic gesso, applied to simulate a canvas texture. This canvas-like tooth provides a bit of brush drag for superb control, and results in brighter, truer-looking colors. Flat panels have a built-in hanging hole. Cradled panels are braced by strong, stable birch plywood. Excellent for palette-knife painting, mixed media, and more.

3/8" Flat Panels			
NUMBER	SIZE	EACH	12/EA
A13635-3044	4" x 4"	\$5.46	\$4.91
A13635-3055	5" x 5"	5.97	5.37
A13635-3066	6" x 6"	6.49	5.84
A13635-3612	6" x 12"	9.59	8.63
A13635-3088	8" x 8"	8.15	7.33
A13635-3810	8" x 10"	9.59	8.63
A13635-3912	9" x 12"	10.82	9.74
A13635-3014	11" x 14"	12.37	11.13
A13635-3012	12" x 12"	12.37	11.13
A13635-3016	12" x 16"	14.13	12.72
A13635-3020	16" x 20"	19.99	17.99
A13635-3024	18" x 24"	24.35	21.91

3/4" Cradled Panels			
NUMBER	SIZE	EACH	12/EA
A13635-4044	4" x 4"	\$4.90	\$4.41
A13635-4055	5" x 5"	5.64	5.08
A13635-4066	6" x 6"	5.87	5.28
A13635-4612	6" x 12"	7.55	6.79
A13635-4088	8" x 8"	7.16	6.44
A13635-4810	8" x 10"	7.55	6.79
A13635-4910	9" x 12"	8.97	8.07
A13635-4014	11" x 14"	10.61	9.55
A13635-4012	12" x 12"	10.61	9.55
A13635-4016	12" x 16"	12.26	11.03

1-1/2" Cradled Panels			
NUMBER	SIZE	EACH	12/EA
A13635-5066	6" x 6"	\$10.24	\$9.22
A13635-5612	6" x 12"	13.22	11.90
A13635-5088	8" x 8"	12.15	10.93
A13635-5810	8" x 10"	13.41	12.07
A13635-5912	9" x 12"	15.59	14.03
A13635-5014	11" x 14"	17.35	15.61
A13635-5012	12" x 12"	17.35	15.61
A13635-5016	12" x 16"	20.91	18.82
A13635-5616	16" x 16"	24.31	21.88
A13635-5020	16" x 20"	25.25	22.72
A13635-5018	18" x 18"	26.44	23.80
A13635-5024	18" x 24"	29.19	26.27

1-1/2" Cradled Panels			
NUMBER	SIZE	EACH	12/EA
A07030-3066	6" x 6"	\$9.73	\$8.75
A07030-3612	6" x 12"	13.23	11.90
A07030-3088	8" x 8"	11.99	10.79
A07030-3810	8" x 10"	14.07	12.65
A07030-3912	9" x 12"	14.98	13.48
A07030-3110	10" x 10"	14.82	13.34
A07030-3114	11" x 14"	18.99	17.09
A07030-3212	12" x 12"	18.48	16.62
A07030-3216	12" x 16"	22.05	19.84
A07030-3616	16" x 16"	26.47	23.81
A07030-3620	16" x 20"	30.88	27.79
A07030-3824	18" x 24"	37.88	34.08

Ampersand™ Value Series Artist Panels — Primed Smooth

This panel features a 1/8" (3 mm) MDF surface, coated on all sides with silky-smooth acrylic gesso primer. This semi-absorbent ground is excellent for painting in oils, acrylics, and waterbased media, and for drawing. Primed Smooth is also great for mounting photos, prints, and canvas. Flat panels have a built-in hanging hole. Cradled panels are braced with solid pine.

1/8" Flat Panels			
NUMBER	SIZE	EACH	12/EA
A13635-0044	4" x 4"	\$1.59	\$1.43
A13635-0057	5" x 7"	3.94	3.55
A13635-0066	6" x 6"	2.88	2.58
A13635-0088	8" x 8"	4.99	4.49
A13635-0810	8" x 10"	6.19	5.56
A13635-0912	9" x 12"	7.70	6.92
A13635-1010	10" x 10"	7.26	6.52
A13635-1114	11" x 14"	9.40	8.46
A13635-1212	12" x 12"	8.76	7.87
A13635-1216	12" x 16"	10.47	9.42
A13635-1418	14" x 18"	12.28	11.04
A13635-1620	16" x 20"	16.47	14.81
A13635-1824	18" x 24"	17.31	15.57

3/8" Flat Panels			
NUMBER	SIZE	EACH	12/EA
A13635-1044	4" x 4"	\$4.78	\$4.30
A13635-1055	5" x 5"	5.28	4.75
A13635-1057	5" x 7"	5.78	5.20
A13635-1066	6" x 6"	5.99	5.39
A13635-1612	6" x 12"	9.08	8.17
A13635-1088	8" x 8"	7.99	7.19
A13635-1810	8" x 10"	9.33	8.40
A13635-1912	9" x 12"	10.99	9.89
A13635-2110	10" x 10"	10.75	9.67
A13635-2114	11" x 14"	13.63	12.27
A13635-2212	12" x 12"	13.63	12.27
A13635-2216	12" x 16"	17.36	15.62
A13635-2620	16" x 20"	24.79	22.31
A13635-2818	18" x 18"	25.62	23.06
A13635-2824	18" x 24"	31.41	28.27

7/8" Cradled Panels			
NUMBER	SIZE	EACH	12/EA
A07030-2044	4" x 4"	\$6.68	\$5.99
A07030-2046	4" x 6"	7.98	7.17
A07030-2055	5" x 5"	7.98	7.17
A07030-2057	5" x 7"	8.51	7.66
A07030-2066	6" x 6"	8.82	7.93
A07030-2088	8" x 8"	10.99	9.89
A07030-2010	10" x 10"	13.68	12.31
A07030-2114	11" x 14"	17.64	15.88
A07030-2212	12" x 12"	17.64	15.88

1-1/2" Cradled Panels			
NUMBER	SIZE	EACH	12/EA
A07030-3066	6" x 6"	\$9.73	\$8.75
A07030-3612	6" x 12"	13.23	11.90
A07030-3088	8" x 8"	11.99	10.79
A07030-3810	8" x 10"	14.07	12.65
A07030-3912	9" x 12"	14.98	13.48
A07030-3110	10" x 10"	14.82	13.34
A07030-3114	11" x 14"	18.99	17.09
A07030-3212	12" x 12"	18.48	16.62
A07030-3216	12" x 16"	22.05	19.84
A07030-3616	16" x 16"	26.47	23.81
A07030-3620	16" x 20"	30.88	27.79
A07030-3824	18" x 24"	37.88	34.08



Artwork by Stella Alesi, alesart.com

WHY CHOOSE AMPERSAND?

Ampersand is dedicated to providing the best panel painting experience possible. Their Museum Series panels are made with premium US-grown, high-density hardboard and sealed with exclusive Archiva-Seal™ barrier technology, which prevents any support-induced discoloration and any separation of the painting ground from the panel. Archival, eco-friendly, and handmade in the USA, there's a perfect Ampersand panel for every medium.

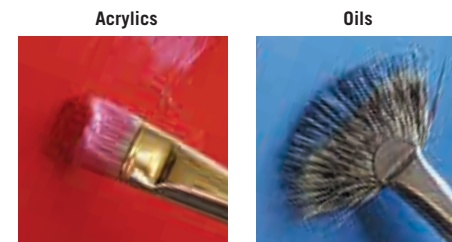

Ampersand™ Aquabord™

This textured clay surface absorbs watercolors like a fine paper, but with significant advantages. This unique surface can never be overworked and it will not tear, shrink, or buckle even under heavy water application like regular papers. Lift, change, and reapply colors endlessly. Aquabord can be gently rinsed off and then used a second time if needed. Spray finished artwork with fixative to seal and eliminate the need for expensive framing. Archival and acid-free.

Find the panel that's right for you!

Panel Comparison Chart	oil	watercolor	ink	acrylic	egg tempera	pastels	monochrome	air brush	very absorbent	non-absorbent	scratchboard	metallic	extra smooth	textured
claybord™														
aquabord™														
gessobord™														
scratchbord™														
pastelbord™														
hardbord™														
encausticbord™														
stampbord™														



1/8" Flat Panels			
NUMBER	SIZE	EACH	12/EA
A14912-2004	4" x 4" (4-Pack)	\$6.35	\$5.72
A14912-2005	5" x 5" (4-Pack)	7.13	6.42
A14912-1001	5" x 7" (3-Pack)	9.77	8.79
A14912-2006	6" x 6" (4-Pack)	8.31	7.48
A14912-2008	8" x 8"	5.58	5.03
A14912-1002	8" x 10"	7.13	6.42
A14912-1003	9" x 12"	8.79	7.91
A14912-1005	11" x 14"	10.27	9.25
A14912-1112	12" x 12"	9.30	8.37
A14912-1006	12" x 16"	13.68	12.32
A14912-1007	14" x 18"	16.62	14.96
A14912-1008	16" x 20"	19.86	17.88
A14912-1009	18" x 24"	23.98	21.58
A14912-1022	22" x 30"	34.38	30.94
A14912-1015	24" x 36"	38.64	34.78

1-1/2" Cradled Panels			
NUMBER	SIZE	EACH	12/EA
A14912-1303	6" x 6"	\$17.31	\$15.58
A14912-1388	8" x 8"	21.65	19.48
A14912-1312	8" x 10"	25.73	23.16
A14912-1305	11" x 14"	31.84	28.66
A14912-1304	12" x 12"	31.84	28.66
A14912-1308	16" x 20"	42.47	38.23
A14912-1309	18" x 24"	48.84	43.96
A14912-1315	24" x 36"	67.31	60.59

2" Cradled Panels			
NUMBER	SIZE	EACH	12/EA
A14912-1011	5" x 5"	\$17.12	\$15.41
A14912-1103	6" x 6"	18.58	16.73
A14912-1021	6" x 8"	21.52	19.37
A14912-1088	8" x 8"	22.99	20.69
A14912-1012	8" x 10"	27.09	24.39
A14912-1105	11" x 14"	34.55	31.09
A14912-1004	12" x 12"	33.76	30.39
A14912-1108	16" x 20"	48.25	43.43
A14912-1122	22" x 30"	63.66	57.30

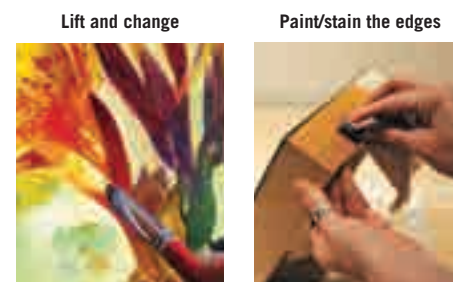

Got a question about a product?
Our experts have the answer!
Three ways to connect —
Live Chat at DickBlick.com, call
800.933.2542, or email info@DickBlick.com

AMPERSAND™ museum series

Ampersand™ Claybord™ for Mixed Media

Forgiving and interactive, Claybord is perfect for students of all ages. The workable, ultra-smooth kaolin clay-coated panel has a velvety smooth finish that's very absorbent. Add inks or thin paint and then scratch through to the clay surface to add texture or tonal value. Remove paint completely using Ampersand's oil-free steel wool. Use this multimedia panel with pencil, acrylics, gouache, watercolor, collage, photo transfers, inks, Scratchbord tools, and more. Archival and acid-free.



See page 242 for Ampersand Floater Frames.

1/8" Flat Panels			
NUMBER	SIZE	EACH	12/EA
A14915-2004	4" x 4" (4-pack)	\$6.96	\$6.27
A14915-2005	5" x 5" (4-pack)	7.48	6.74
A14915-1001	5" x 7" (3-pack)	10.18	9.16
A14915-2006	6" x 6" (4-pack)	9.11	8.20
A14915-2008	8" x 8"	6.12	5.51
A14915-1002	8" x 10"	7.48	6.74
A14915-1003	9" x 12"	10.40	9.36
A14915-1005	11" x 14"	11.79	10.61
A14915-1024	12" x 12"	12.53	11.28
A14915-1006	12" x 16"	14.99	13.49
A14915-1026	12" x 24"	17.14	15.43
A14915-1007	14" x 18"	16.82	15.14
A14915-1008	16" x 20"	21.33	19.20
A14915-1009	18" x 24"	24.65	22.18
A14915-1136	18" x 36"	32.68	29.41
A14915-1015	24" x 36"	39.20	35.28

3/4" Cradled Panels			
NUMBER	SIZE	EACH	12/EA
A14915-1055	5" x 5"	\$15.52	\$13.97
A14915-2103	6" x 6"	16.39	14.75
A14915-2088	8" x 8"	19.60	17.64
A14915-1012	8" x 10"	22.48	20.24
A14915-2912	9" x 12"	25.18	22.66
A14915-1115	11" x 14"	27.53	24.78
A14915-2216	12" x 16"	31.61	28.45
A14915-1114	12" x 12"	29.26	26.33
A14915-1223	12" x 24"	37.17	33.46
A14915-1018	14" x 18"	35.67	32.11
A14915-1118	16" x 20"	38.90	35.03
A14915-2825	18" x 24"	44.89	40.41
A14915-1113	18" x 36"	50.70	45.63
A14915-1016	24" x 36"	64.28	57.86

1-1/2" Cradled Panels			
NUMBER	SIZE	EACH	12/EA
A14915-2055	5" x 5"	\$18.07	\$16.27
A14915-2066	6" x 6"	18.96	17.07
A14915-2108	8" x 8"	23.71	21.34
A14915-2010	8" x 10"	28.19	25.37
A14915-2012	9" x 12"	30.33	27.30
A14915-2110	10" x 10"	30.24	27.22
A14915-2014	11" x 14"	34.88	31.40
A14915-2112	12" x 12"	34.88	31.40
A14915-2116	12" x 16"	37.49	33.75
A14915-2016	16" x 16"	39.99	35.99
A14915-2020	16" x 20"	46.53	41.88
A14915-2018	18" x 24"	53.51	48.16
A14915-2024	24" x 24"	62.18	55.97
A14915-2036	24" x 36"	73.73	66.37

2" Cradled Panels XL Sizes			
NUMBER	SIZE	EACH	2/EA
A13325-1026	30" x 40"	\$135.70	\$122.10
A13325-1036	36" x 36"	166.50	149.90
A13325-1027	36" x 48"	191.70	172.50

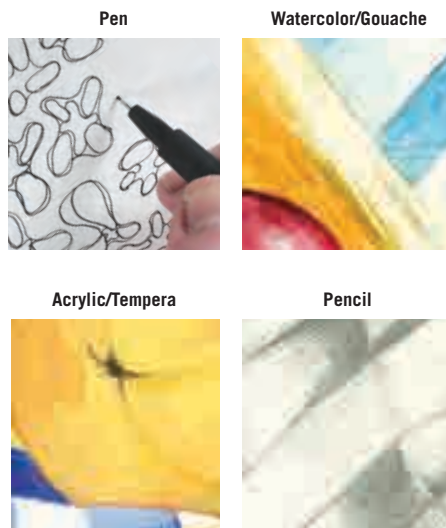

2" Cradled Panels			
NUMBER	SIZE	EACH	12/EA
A14915-1011	5" x 5"	\$20.25	\$18.22
A14915-1103	6" x 6"	21.32	19.19
A14915-1121	6" x 8"	24.63	22.17
A14915-1061	6" x 12"	27.11	24.41
A14915-1068	6" x 18"	35.35	31.82
A14915-1624	6" x 24"	43.21	38.89
A14915-1088	8" x 8"	26.68	23.99
A14915-1112	8" x 10"	31.62	28.46
A14915-1816	8" x 16"	36.12	32.52
A14915-1824	8" x 24"	43.42	39.08
A14915-1912	9" x 12"	33.76	30.39
A14915-1010	10" x 10"	33.76	30.39
A14915-1020	10" x 20"	11.42	10.28
A14915-1031	10" x 30"	51.35	46.22
A14915-1105	11" x 14"	39.97	35.98
A14915-1104	12" x 12"	39.12	35.22
A14915-1216	12" x 16"	41.80	37.62
A14915-1224	12" x 24"	49.62	44.66
A14915-1236	12" x 36"	66.14	59.54
A14915-1616	16" x 16"	44.90	40.42
A14915-1108	16" x 20"	52.84	47.56
A14915-1825	18" x 24"	60.35	54.32
A14915-1102	24" x 24"	69.72	62.75
A14915-2430	24" x 30"	76.49	68.85
A14915-2436	24" x 36"	82.57	74.32
A14915-3030	30" x 30"	88.99	80.12

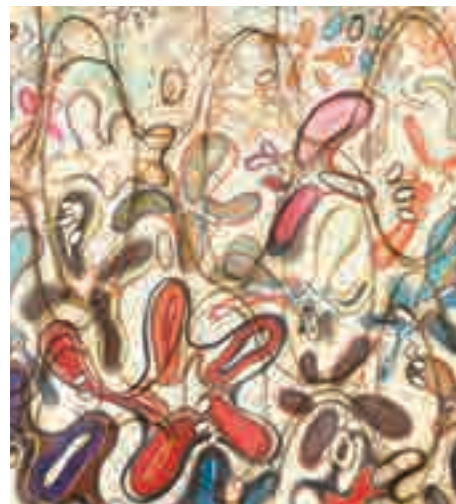

Artwork by Cynthia Mosser, cynthiamosser.com



Ampersand™ Hardbord™

Build up your own unique painting grounds and textures on this ultra-stable, artist-grade hardboard support. Its high-density fiber core is engineered for stability, eliminating the warping and bowing issues found in other substrates. Moisture-resistant and formaldehyde-free, Hardbord is the substrate for all Museum Series panels. Prime with the ground of your choice or use as a support for mounting.

1/8" Flat Panels			
NUMBER	SIZE	EACH	12/EA
A14941-0057	5" x 7" (3-Pack)	\$6.93	\$6.24
A14941-0810	8" x 10"	5.11	4.60
A14941-0912	9" x 12"	6.39	5.75
A14941-1114	11" x 14"	7.88	7.10
A14941-1212	12" x 12"	7.69	6.92
A14941-1216	12" x 16"	8.53	7.68
A14941-1224	12" x 24"	9.59	8.64
A14941-1418	14" x 18"	9.38	8.44
A14941-1620	16" x 20"	10.45	9.41
A14941-1824	18" x 24"	13.55	12.19
A14941-1836	18" x 36"	20.81	18.73
A14941-2436	24" x 36"	23.69	21.32

3/4" Cradled Panels			
NUMBER	SIZE	EACH	12/EA
A14910-1022	8" x 10"	\$18.23	\$16.41
A14910-1025	11" x 14"	21.91	19.72
A14910-1024	12" x 12"	23.11	20.80
A14910-1029	12" x 24"	27.35	24.62
A14910-1030	14" x 18"	24.13	21.72
A14910-1028	16" x 20"	28.74	25.87
A14910-1009	18" x 24"	32.41	29.18
A14910-1023	18" x 36"	38.87	34.99
A14910-1016	24" x 36"	50.11	45.10

2" Cradled Panels			
NUMBER	SIZE	EACH	12/EA
A14927-1021	6" x 8"	\$18.05	\$16.25
A14927-1012	8" x 10"	22.79	20.51
A14927-1005	11" x 14"	29.46	26.51
A14927-1004	12" x 12"	28.93	26.04
A14927-1008	16" x 20"	39.89	35.90
A14927-1002	24" x 24"	52.69	47.43



Artwork by Greg Skol, gregskol.com

Gessobord™ features:

- Primed with superior quality artist-grade gesso
- Slight, even texture for ideal brush control
- Surface texture doesn't become a distracting part of your image
- Smooth finishes and even tonal values
- Can hold heavy applications

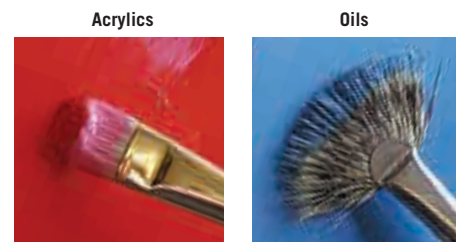

2" Cradle XL Sizes Buy two and save!

Gessobord			
NUMBER	SIZE	EACH	2/EA
A13616-1026	30" x 40"	\$118.60	\$106.70
A13616-1027	36" x 48"	167.80	151.10
A13616-1036	36" x 36"	158.60	142.80

Claybord			
NUMBER	SIZE	EACH	2/EA
A13325-1026	30" x 40"	\$135.70	\$122.10
A13325-1036	36" x 36"	166.50	149.90
A13325-1027	36" x 48"	191.70	172.50

AMPERSAND™ museum series

See page 242 for Ampersand Floater Frames.



Ampersand™ Gessobord™

Perfect for oils or acrylics, Gessobord is also a great surface for mixed media. Acid-free and archival, it's coated with an acrylic gesso ground — no priming required!

1/8" Flat Panels			
NUMBER	SIZE	EACH	12/EA
A14911-2004	4" x 4" (4-Pack)	\$6.82	\$6.14
A14911-2005	5" x 5" (4-Pack)	7.37	6.63
A14911-1001	5" x 7" (3-Pack)	9.06	8.15
A14911-2006	6" x 6" (4-Pack)	8.87	7.98
A14911-1021	6" x 8" (3-Pack)	10.66	9.59
A14911-2008	8" x 8"	6.25	5.62
A14911-1002	8" x 10"	7.65	6.88
A14911-1003	9" x 12"	9.33	8.40
A14911-1010	10" x 10"	8.64	7.78
A14911-1005	11" x 14"	10.92	9.83
A14911-1024	12" x 12"	11.87	10.68
A14911-1006	12" x 16"	13.54	12.19
A14911-1026	12" x 24"	17.10	15.39
A14911-1017	14" x 18"	16.35	14.71
A14911-1316	16" x 16"	16.70	15.03
A14911-1008	16" x 20"	19.61	17.65
A14911-1009	18" x 24"	23.64	21.28
A14911-1013	18" x 36"	30.16	27.14
A14911-1015	24" x 36"	38.05	34.24

1-1/2" Cradled Panels			
NUMBER	SIZE	EACH	12/EA
A14911-2055	5" x 5"	\$16.06	\$14.45
A14911-2066	6" x 6"	17.31	15.58
A14911-2108	8" x 8"	21.44	19.30
A14911-2010	8" x 10"	25.27	22.74
A14911-2012	9" x 12"	27.22	24.50
A14911-2110	10" x 10"	27.14	24.43
A14911-2014	11" x 14"	30.73	27.66
A14911-2112	12" x 12"	30.73	27.66
A14911-2116	12" x 16"	33.07	29.76
A14911-2016	16" x 16"	35.96	32.36
A14911-2018	18" x 24"	47.66	42.89
A14911-2001	20" x 24"	50.31	45.28
A14911-2024	24" x 24"	57.34	51.61
A14911-2013	24" x 30"	63.65	57.28
A14911-2036	24" x 36"	65.37	58.83

2" Cradled Panels			
NUMBER	SIZE	EACH	12/EA
A14911-1011	5" x 5"	\$17.74	\$15.97
A14911-1103	6" x 6"	19.32	17.39
A14911-1121	6" x 8"	22.41	20.17
A14911-1612	6" x 12"	24.27	21.84
A14911-1618	6" x 18"	31.76	28.58
A14911-1106	6" x 24"	38.75	34.87
A14911-1088	8" x 8"	23.82	21.44
A14911-1112	8" x 10"	28.03	25.23
A14911-1816	8" x 16"	32.22	28.99
A14911-1912	8" x 24"	38.75	34.87
A14911-1091	9" x 12"	30.36	27.32
A14911-1110	10" x 10"	30.17	27.15
A14911-1020	10" x 20"	38.58	34.72
A14911-1030	10" x 30"	45.77	41.19
A14911-1105	11" x 14"	35.03	31.53
A14911-1104	12" x 12"	34.28	30.85
A14911-1216	12" x 16"	36.89	33.20
A14911-1224	12" x 24"	44.18	39.76
A14911-1212	12" x 36"	58.76	52.88
A14911-1116	16" x 16"	40.08	36.07
A14911-1108	16" x 20"	48.87	43.98
A14911-1824	18" x 24"	53.53	48.18
A14911-1102	24" x 24"	63.78	57.40
A14911-2430	24" x 30"	67.76	60.98
A14911-1124	24" x 36"	72.91	65.62
A14911-1130	30" x 30"	77.81	70.03



Ampersand™ Scratchbord™

Scratchbord has a smooth, absorbent kaolin clay ground that is evenly coated with India ink. Scrape it back in crisp, clean lines to create exquisitely detailed white-on-black art. Acid-free and archival, it won't tear, crack, or bend. 1/8" deep panel.

NUMBER	SIZE	EACH	12/EA
A14914-2053	5" x 5" (3-Pack)	\$7.73	\$6.96
A14914-2001	5" x 7" (3-Pack)	10.63	9.57
A14914-2063	6" x 6" (3-Pack)	9.34	8.41
A14914-2080	8" x 8"	6.66	5.99
A14914-2002	8" x 10"	8.04	7.23
A14914-2003	9" x 12"	10.63	9.57
A14914-2005	11" x 14"	11.86	10.68
A14914-2004	12" x 12"	12.49	11.24
A14914-2006	12" x 16"	15.16	13.64
A14914-2007	14" x 18"	16.92	15.23
A14914-2008	16" x 20"	19.98	17.98
A14914-2009	18" x 20"	23.81	21.43
A14914-2015	24" x 36"	36.60	32.94

Ampersand™ Scratchbord™ Tool Kit

For best results with Scratchbord and Claybord, start with this complete set of scratch tools. The Scratchbord Tool Kit includes one of each of the tools shown below, a free sample of Claybord for experimentation, and a pad of oil-free steel wool. Instructions for each tool provided on the package.



NUMBER	EACH	10/EA
A14913-1009	\$34.90	\$31.41



For Soft Tonal Values

Ampersand™ Scratchbord™ Fiber Brush

Use the fiber brush like a regular eraser to soften crisp edges and to create gradual tonal values. Fiber brush contains fiberglass; not recommended for use by unsupervised children.

NUMBER	EACH	10/EA
A14913-0030	\$16.03	\$14.43



For Drawing and Fine Details

Ampersand™ Scratchbord™ Knife

The scratch knife is the best tool to select when trying Scratchbord for the first time. Comes with two ribs: curved and fine point.

NUMBER	EACH	10/EA
A14913-0000	\$7.97	\$7.18

Ampersand™ Scratchbord™ Ink Set

Add vibrant color to your projects with inks specifically designed for Scratchbord and Claybord. These pigmented inks are permanent, transparent, and waterproof. Set includes six 0.5 oz (15 ml) bottles in Carmine Red, Light Green, Sepia, Ultramarine Blue, Yellow, and Black Repair.



NUMBER	EACH	6/EA
A21100-1009	\$18.55	\$16.69



For Easy Cross-Hatching

Ampersand™ Scratchbord™ Line Tool

This line tool makes five precise parallel lines at once. Cross-hatching, highlighting, and softening sharp details is fast and efficient.

NUMBER	EACH	10/EA
A14913-0010	\$12.71	\$11.44



For Hair, Grass, and Fur Textures

Ampersand™ Scratchbord™ Wire Brush

The curved stainless steel wires are perfect for random patterns like grass and fur.

NUMBER	EACH	10/EA
A14913-0020	\$9.43	\$8.49



Ampersand™ Stampbord™

A phenomenal surface for rubber stamping and mixed media, Stampbord features a wood backing and absorbent clay surface that grabs the ink from rubber stamps, leaving a clean, pristine image without smearing. Then scratch or etch into the surface to create incredible details and highlights. For more details, visit DickBlick.com.

NUMBER	SIZE	PKG	EACH	12/EA
A13625-1001	2-1/2" x 3-1/2"	5	\$5.84	\$5.26
A13625-1003	2-1/2" x 3-1/2"	16	15.94	14.35
A13625-1005	1/2 lb Bag	approx 40	11.37	10.24
A13625-1010	10 lb Bag	approx 440	38.39	34.56

Great for miniature paintings, trading cards, and embellishments.



Ampersand™ Pastelbord™

Pastelbord is a versatile and rigid panel for pastels. The textured surface has marble dust granules like a fine sandpaper and is perfect for both soft pastels (stick or pencil) and oil pastels. Pastels go on smooth, blend beautifully, and colors stay rich and vibrant while holding tight to the surface, layer after layer. Pastelbord is forgiving — the surface can be gently rinsed and used a second time. Dark Green and Sand make the perfect background for portraits and landscapes. White can be toned with soft pastels and water. Gray is a middle value, suitable for all subjects.

NUMBER	SIZE	EACH	12/EA
A08910-7030	5" x 7" (3-Pack)	\$12.12	\$10.91
A08910-7032	8" x 10"	8.70	7.83
A08910-7034	11" x 14"	12.48	11.23
A08910-7038	16" x 20"	22.53	20.27
A08910-7039	18" x 24"	26.84	24.16

Gray	NUMBER	SIZE	EACH	12/EA
	A08910-2220	5" x 7" (3-Pack)	\$12.12	\$10.91
	A08910-1011	6" x 6"	7.18	6.46
	A08910-1012	6" x 12"	8.52	7.67
	A08910-1017	6" x 18"	11.31	10.18
	A08910-1002	8" x 10"	8.70	7.83
	A08910-1005	11" x 14"	12.48	11.23
	A08910-1014	12" x 12"	13.45	12.11
	A08910-1006	12" x 16"	15.25	13.73
	A08910-1008	16" x 20"	22.53	20.27
	A08910-1009	18" x 24"	26.84	24.16
	A08910-1015	24" x 36"	40.05	36.05

Sand	NUMBER	SIZE	EACH	12/EA
	A08910-8510	5" x 7" (3-Pack)	\$12.12	\$10.91
	A08910-8512	8" x 10"	8.70	7.83
	A08910-8514	11" x 14"	12.48	11.23
	A08910-8516	12" x 16"	15.25	13.73
	A08910-8518	16" x 20"	22.53	20.27
	A08910-8519	18" x 24"	26.84	24.16

White	NUMBER	SIZE	EACH	12/EA
	A08910-1020	5" x 7" (3-Pack)	\$12.12	\$10.91
	A08910-1021	6" x 6"	7.18	6.46
	A08910-1024	6" x 12"	8.52	7.67
	A08910-1027	6" x 18"	11.31	10.18
	A08910-1022	8" x 10"	8.70	7.83
	A08910-1025	11" x 14"	12.48	11.23
	A08910-1026	12" x 16"	15.25	13.73
	A08910-1028	16" x 20"	22.53	20.27
	A08910-1029	18" x 24"	26.84	24.16

Ampersand™ Pastelbord™ Pack of 4

Includes one 5" x 7" panel of each color: Dark Green, Gray, Sand, and White.

NUMBER	EACH	12/EA
A08910-1004	\$13.26	\$11.94

BLICK® super value packs

- Budget-friendly value packs
- Ideal for wall groupings and art shows
- Pair frames with canvas panels and wood panels



Blick® Super Value Wood Panel Packs

These wallet-friendly bundled packs feature panels with a smooth, hand-sanded 4 mm birch surface. The panels are supported by a sturdy pine cradle and have a 3/4" deep profile. Use them for painting, encaustics, mixed media, and more. Hang with or without a frame. Beautiful when combined with an 8" x 8", 9" x 12", or 11" x 14" Blick Super Value Floater Frame! Note: The panel will extend slightly beyond the frame's profile.

NUMBER	SIZE	PKG	EACH
A07061-1608	8" x 8"	6	\$33.05
A07061-1512	8" x 10"	5	33.05
A07061-1523	9" x 12"	5	33.05
A07061-1509	10" x 10"	5	33.05
A07061-1405	11" x 14"	4	33.05
A07061-1404	12" x 12"	4	33.05



Blick® Edu-Painting Panel Class Packs

Primed to create a fine-weave, linen-like texture, these 1/8" thick, non-warping panels require less paint to cover, making them an affordable option for the classroom. They offer all the advantages of painting on a prepared wood panel. Sold in packs of 12.

NUMBER	SIZE	EACH
A13618-1066	6" x 6"	\$19.88
A13618-1088	8" x 8"	28.06
A13618-1012	8" x 10"	32.65
A13618-1023	9" x 12"	38.50
A13618-1005	11" x 14"	52.05
A13618-1212	12" x 12"	50.40



See Page 144 for Super Value Canvas Packs.



Blick® Super Value Floater Frame Packs

Another super value from Blick! Specially designed to hold Blick Super Value Stretched Canvases and select sizes of Super Value Wood Panels (8" x 8", 9" x 12", and 11" x 14"), these black frames come equipped with industrial-grade adhesive for quick, easy canvas mounting, and sawtooth hangers for vertical or horizontal hanging. Inside frame depth is 0.625". Made of recycled materials. Note: Super Value Canvases will be flush with the frame. Super Value Wood Panels will extend slightly beyond the frame's profile.

NUMBER	SIZE	PKG	EACH
A18715-2022	8" x 10"	5	\$51.93
A18715-2023	9" x 12"	4	52.52
A18715-2028	16" x 20"	5	110.38

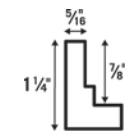

BLICK® premier wood panels

Blick Premier Wood Panels

These panels feature a premium select 4 mm basswood surface and a solid basswood cradle. Basswood is known for its fine, uniform characteristics, limited wood grain, and proven stability over time. Each panel is precision-crafted, meticulously sanded on all sides, and ready to prime with the ground of your choice. A popular surface for heavy paint applications, encaustics, collages, and more.

7/8" Cradled Panels				1-1/2" Cradled Panels			
NUMBER	SIZE	EACH	6/EA	NUMBER	SIZE	EACH	6/EA
A13690-1046	4" x 6"	\$7.27	\$6.54	A13681-1035	3" x 5"	\$6.44	\$5.80
A13690-1057	5" x 7"	8.57	7.71	A13681-1044	4" x 4"	6.44	5.80
A13690-1066	6" x 6"	8.57	7.71	A13681-1055	5" x 5"	7.57	6.81
A13690-1068	6" x 8"	9.85	8.87	A13681-1057	5" x 7"	9.08	8.17
A13690-1088	8" x 8"	11.61	10.45	A13681-1066	6" x 6"	8.64	7.78
A13690-1612	6" x 12"	12.35	11.12	A13681-1068	6" x 8"	10.37	9.33
A13690-1810	8" x 10"	13.34	11.99	A13681-1612	6" x 12"	13.19	11.87
A13690-1912	9" x 12"	14.88	13.40	A13681-1088	8" x 8"	11.68	10.51
A13690-1020	10" x 20"	21.11	18.99	A13681-1810	8" x 10"	13.94	12.55
A13690-1114	11" x 14"	18.75	16.88	A13681-1912	9" x 12"	15.62	14.06
A13690-1212	12" x 12"	18.07	16.26	A13681-1010	10" x 10"	15.17	13.65
A13690-1216	12" x 16"	20.24	18.22	A13681-1020	10" x 20"	22.42	20.18
A13690-1224	12" x 24"	29.38	26.45	A13681-1114	11" x 14"	19.99	17.99
A13690-1236	12" x 36"	42.22	37.99	A13681-1212	12" x 12"	18.93	17.05
A13690-1414	14" x 14"	20.62	18.56	A13681-1216	12" x 16"	21.24	19.11
A13690-1418	14" x 18"	24.87	22.39	A13681-1218	12" x 18"	21.97	19.77
A13690-1616	16" x 16"	26.68	23.99	A13681-1224	12" x 24"	29.05	26.15
A13690-1620	16" x 20"	30.10	27.10	A13681-1236	12" x 36"	43.55	39.19
A13690-1818	18" x 18"	30.10	27.10	A13681-1248	12" x 48"	57.19	51.47
A13690-1824	18" x 24"	38.11	34.31	A13681-1414	14" x 14"	20.67	18.60
A13690-2020	20" x 20"	36.62	32.97	A13681-1418	14" x 18"	24.50	22.05
A13690-2424	24" x 24"	50.58	45.54	A13681-1616	16" x 16"	28.03	25.22
A13690-2436	24" x 36"	66.72	60.07	A13681-1620	16" x 20"	30.67	27.60

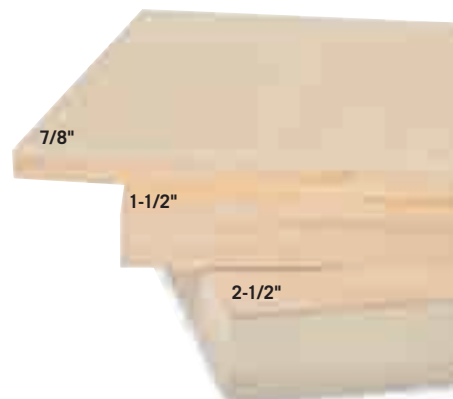

1-1/2" Cradled Panels — *Truck Shipment. See page 648 for details.

NUMBER	SIZE	EACH	6/EA
A13681-1818	18" x 18"	\$30.68	\$27.61
A13681-1824	18" x 24"	37.85	34.06
A13681-2020	20" x 20"	35.30	31.76
A13681-2024	20" x 24"	40.38	36.34
A13681-2424	24" x 24"	55.45	49.90
A13681-2430	24" x 30"	58.71	52.83
A13681-2436	24" x 36"	77.57	69.81
A13681-3040	30" x 40"	107.27	96.53
A13681-3636	*36" x 36"	110.46	99.40
A13681-3648	*36" x 48"	147.35	132.61

2-1/2" Cradled Panels — *Truck Shipment. See page 648 for details.

NUMBER	SIZE	EACH	6/EA
A07042-2424	24" x 24"	\$68.47	\$61.62
A07042-3030	30" x 30"	99.42	89.46
A07042-3060	*30" x 60"	176.12	158.49
A07042-3636	*36" x 36"	145.39	130.83
A07042-3648	*36" x 48"	192.83	173.53
A07042-3672	*36" x 72"	259.43	233.45
A07042-4860	*48" x 60"	302.00	271.68
A07042-4872	*48" x 72"	350.00	315.00

BLICK® studio wood panels

Blick Studio Wood Panels

Good quality at a great price! These panels feature a 4 mm basswood plywood surface cradled by a highly stable pine frame that won't warp or bend. Both the surface and the frame are sanded for smoothness. Excellent for hobbyists, students, and beginners.

7/8" Profile			
NUMBER	SIZE	EACH	6/EA
A07044-1044	4" x 4"	\$4.33	\$3.90
A07044-1046	4" x 6"	5.18	4.66
A07044-1055	5" x 5"	5.18	4.66
A07044-1057	5" x 7"	5.83	5.25
A07044-1066	6" x 6"	5.83	5.25
A07044-1068	6" x 8"	6.74	6.06
A07044-1612	6" x 12"	8.47	7.62
A07044-1088	8" x 8"	7.72	6.95
A07044-1810	8" x 10"	8.97	8.07
A07044-1912	9" x 12"	10.36	9.33
A07044-1010	10" x 10"	9.93	8.94
A07044-1020	10" x 20"	15.71	14.14
A07044-1114	11" x 14"	12.90	11.61
A07044-1212	12" x 12"	12.65	11.39
A07044-1216	12" x 16"	14.87	13.39
A07044-1224	12" x 24"	20.41	18.37
A07044-1236	12" x 36"	28.43	25.59
A07044-1414	14" x 14"	15.05	13.54
A07044-1418	14" x 18"	18.43	16.59
A07044-1616	16" x 16"	18.43	16.59
A07044-1620	16" x 20"	21.72	19.55
A07044-1818	18" x 18"	20.41	18.37
A07044-1824	18" x 24"	26.58	23.93
A07044-2020	20" x 20"	25.40	22.86
A07044-2424	24" x 24"	33.74	30.37
A07044-2436	24" x 36"	46.84	42.15

1-1/2" Profile			
NUMBER	SIZE	EACH	6/EA
A07045-1035	3" x 5"	\$4.68	\$4.21
A07045-1044	4" x 4"	4.68	4.21
A07045-1055	5" x 5"	5.69	5.12
A07045-1057	5" x 7"	6.35	5.71
A07045-1066	6" x 6"	6.35	5.71
A07045-1068	6" x 8"	7.27	6.54
A07045-1612	6" x 12"	9.20	8.27
A07045-1088	8" x 8"	8.37	7.52
A07045-1810	8" x 10"	9.44	8.49
A07045-1912	9" x 12"	10.89	9.79
A07045-1010	10" x 10"	10.62	9.54
A07045-1020	10" x 20"	16.90	15.19
A07045-1114	11" x 14"	13.96	12.55
A07045-1212	12" x 12"	13.57	12.20
A07045-1216	12" x 16"	16.25	14.61
A07045-1218	12" x 18"	17.31	15.56
A07045-1224	12" x 24"	20.24	18.20
A07045-1236	12" x 36"	31.50	28.32
A07045-1248	12" x 48"	39.49	35.50
A07045-1414	14" x 14"	16.47	14.81
A07045-1418	14" x 18"	19.32	17.37
A07045-1616	16" x 16"	19.32	17.37
A07045-1620	16" x 20"	22.45	20.18

1-1/2" Profile — *Truck Shipment. See page 648 for details.

NUMBER	SIZE	EACH	6/EA
A07045-1818	18" x 18"	\$20.99	\$18.89
A07045-1824	18" x 24"	27.14	24.40
A07045-2020	20" x 20"	25.43	22.86
A07045-2024	20" x 24"	30.62	27.52
A07045-2424	24" x 24"	37.20	33.44
A07045-2430	24" x 30"	43.34	38.96
A07045-2436	24" x 36"	51.96	46.71
A07045-3040	*30" x 40"	66.44	59.73
A07045-3636	*36" x 36"	71.63	64.40
A07045-3648	*36" x 48"	91.62	82.37

2-1/2" Profile — *Truck Shipment. See page 648 for details.

NUMBER	SIZE	EACH	6/EA
A07043-2424	24" x 24"	\$47.39	\$42.65
A07043-3030	30" x 30"	73.38	66.05
A07043-3060	*30" x 60"	139.24	125.32
A07043-3636	*36" x 36"	110.85	99.76
A07043-3648	*36" x 48"	148.03	133.24
A07043-3672	*36" x 72"	202.31	182.08
A07043-4860	*48" x 60"	231.25	208.12
A07043-4872	*48" x 72"	269.46	242.52

BLICK® premier artists' panels

Blick Premier Artists' Panels

Primed on all sides with premium, archival, acid-free gesso. The silky-smooth finish is ideal for painting, drawing, and mixed media work, as well as for mounting canvas, paper, and photos. The 3/8" profile flat panel is solid MDF with a built-in hanging hole and no cradle. The 7/8" and 1-1/2" profiles have a 3 mm MDF surface braced by a solid pine cradle.

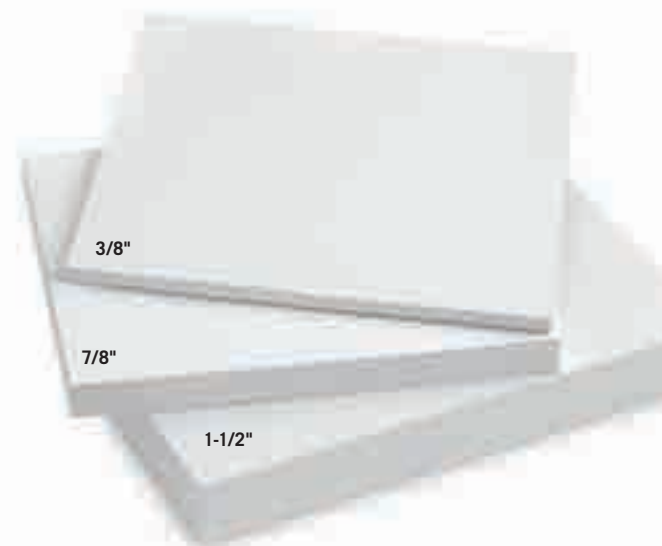
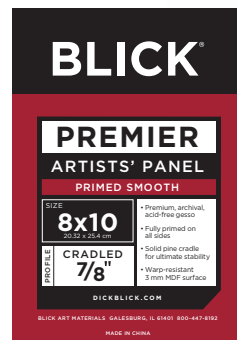

3/8" Flat Panels				7/8" Cradled Panels			
NUMBER	SIZE	EACH	6/EA	NUMBER	SIZE	EACH	6/EA
A07037-1044	4" x 4"	\$4.10	\$3.69	A07041-1044	4" x 4"	\$6.23	\$5.60
A07037-1055	5" x 5"	4.61	4.15	A07041-1046	4" x 6"	7.80	6.99
A07037-1057	5" x 7"	5.38	4.84	A07041-1055	5" x 5"	7.80	6.99
A07037-1066	6" x 6"	5.39	4.85	A07041-1057	5" x 7"	8.22	7.39
A07037-1612	6" x 12"	8.05	7.24	A07041-1066	6" x 6"	8.59	7.72
A07037-1088	8" x 8"	6.91	6.22	A07041-1612	6" x 12"	12.06	10.84
A07037-1810	8" x 10"	8.22	7.39	A07041-1088	8" x 8"	11.18	10.05
A07037-1912	9" x 12"	9.56	8.60	A07041-1810	8" x 10"	12.67	11.39
A07037-1010	10" x 10"	9.83	8.84	A07041-1912	9" x 12"	14.21	12.77
A07037-1114	11" x 14"	11.96	10.76	A07041-1010	10" x 10"	14.05	12.63
A07037-1212	12" x 12"	12.05	10.83	A07041-1114	11" x 14"	17.68	15.90
A07037-1216	12" x 16"	14.97	13.47	A07041-1212	12" x 12"	17.27	15.52
A07037-1620	16" x 20"	21.99	19.79	A07041-1216	12" x 16"	20.48	18.41
A07037-1818	18" x 18"	22.73	20.45	A07041-1616	16" x 16"	24.74	22.25
A07037-1824	18" x 24"	27.77	24.99	A07041-1620	16" x 20"	29.05	26.11
				A07041-1824	18" x 24"	35.72	32.11

1-1/2" Cradled Panels			
NUMBER	SIZE	EACH	6/EA
A07032-1057	5" x 7"	\$8.75	\$7.88
A07032-1066	6" x 6"	9.29	8.36
A07032-1612	6" x 12"	12.68	11.41
A07032-1088	8" x 8"	11.61	10.45
A07032-1810	8" x 10"	13.37	12.05
A07032-1912	9" x 12"	15.11	13.60
A07032-1010	10" x 10"	14.67	13.21
A07032-1114	11" x 14"	18.67	16.81
A07032-1212	12" x 12"	18.50	16.65
A07032-1216	12" x 16"	21.89	19.70
A07032-1616	16" x 16"	25.62	23.06
A07032-1620	16" x 20"	29.97	26.98
A07032-1824	18" x 24"	37.26	33.54

BLICK® studio artists' panels

Blick Studio Artists' Panels

Ready-to-paint MDF panels for artists, students, and leisure painters. The primed surface has a fine, canvas-like tooth for great brush control and intensity of color. The 3/8" profile flat panel is solid MDF with a built-in hanging hole and no cradle. The 3/4" and 1-1/2" profiles have a 3 mm MDF surface braced by an unfinished plywood cradle.

3/8" Flat Panels			
NUMBER	SIZE	EACH	12/EA
A13612-0044	4" x 4"	\$3.99	\$3.59
A13612-0057	5" x 7"	5.27	4.74
A13612-0066	6" x 6"	5.17	4.65
A13612-0612	6" x 12"	7.70	6.93
A13612-0088	8" x 8"	6.52	5.87
A13612-0810	8" x 10"	7.80	6.99
A13612-0912	9" x 12"	8.87	7.98
A13612-1010	10" x 10"	9.19	8.26
A13612-1114	10" x 14"	10.86	9.76
A13612-1212	12" x 12"	10.74	9.66
A13612-1216	12" x 16"	12.11	10.90
A13612-1620	16" x 20"	18.37	16.53
A13612-1818	18" x 18"	18.53	16.67
A13612-1824	18" x 24"	22.48	20.22

1-1/2" Cradled Panels			
NUMBER	SIZE	EACH	12/EA
A13610-0044	4" x 4"	\$8.31	\$7.49
A13610-0057	5" x 7"	10.33	9.31
A13610-0066	6" x 6"	10.15	9.15
A13610-0612	6" x 12"	12.80	11.53
A13610-0088	8" x 8"	11.88	10.71
A13610-			



BLICK® canvas rolls

Blick Medium Weight

Blick® Medium Weight Canvas Rolls

Blick's best-selling, medium weight 7 oz, 100% cotton duck canvas is double blade-coated with acrylic primer — ideal for painting with oils, acrylics, or alkyds. Rolls are 64-1/2" wide, in your choice of two lengths.

NUMBER	SIZE	EACH	12/EA
A07309-1363	3 yd Roll	\$43.45	\$39.10
A07309-1663	6 yd Roll	85.83	77.25

Type CD-50

Type CD-10

Type CD-12

Blick® Unprimed Cotton Canvas Rolls

These unprimed cotton canvas rolls come in a range of weights, textures, and weaves suitable for everything from quick studies to monumental installations. The quality lives up to the highest standards required for permanent painting.

Type CD-50 — A lightweight 9.5 oz canvas with a medium texture and combination weave. An excellent choice for students or painters on a budget.

NUMBER	SIZE	EACH	6/EA
A07377-0272	72"W x 2 yd Roll	\$25.05	\$22.51
A07377-0472	72"W x 4 yd Roll	54.06	48.57
A07377-0672	72"W x 6 yd Blanket	79.94	71.94

Type CD-10 — Heavyweight 15 oz cotton duck. Double weave with a medium-rough texture. Preferred by artists who want a visible surface texture and enjoy the feel against their brush.

NUMBER	SIZE	EACH	6/EA
A07375-0160	60"W x 1 yd Roll	\$22.46	\$20.20
A07375-0260	60"W x 2 yd Roll	29.44	26.49
A07375-0460	60"W x 4 yd Roll	60.32	54.29

Type CD-12 — Double weave, medium weight 12 oz cotton duck with a universally appealing medium-smooth texture.

NUMBER	SIZE	EACH	6/EA
A07376-0160	60"W x 1 yd Roll	\$17.10	\$15.39
A07376-0660	60"W x 6 yd Roll	79.99	71.99
A07376-0460	60"W x 4 yd Roll	54.34	48.91
A07376-1060	60"W x 10 yd Roll	131.28	118.15
A07376-1072	72"W x 10 yd Roll	170.36	153.34
A07376-0472	72"W x 4 yd Roll	73.60	66.24
A07376-0484	84"W x 4 yd Roll	75.57	67.99
A07376-0684	84"W x 6 yd Roll	111.17	100.06
A07376-1084	84"W x 10 yd Roll	178.62	160.77

Utrecht® Primed Cotton Canvas Rolls

These high-quality cotton canvas rolls are primed with acrylic gesso, suitable for oils, acrylics, or alkyds.

Master's Cotton — 12 oz, single weave, pure cotton duck is primed with three coats of acrylic gesso for a bright, flexible ground with a 15 oz primed weight.

NUMBER	SIZE	EACH	6/EA
A07390-6006	60"W x 6 yd Roll	\$276.23	\$248.60

Artists' Cotton — Medium texture, combination weave, 10 oz cotton duck is triple-primed to reach a 14 oz primed weight.

NUMBER	SIZE	EACH	6/EA
A07385-6006	60"W x 6 yd Roll	\$147.63	\$132.87
A07385-8406	84"W x 6 yd Roll	215.57	193.99

Studio Series Cotton — Lightweight 5 oz cotton duck has a smooth texture and is double-primed with acrylic gesso to reach an 8 oz primed weight.

NUMBER	DESCRIPTION	EACH	6/EA
A07389-6054	54"W x 6 yd Roll	\$109.22	\$98.30
A07381-1060	60"W x 6 yd Roll	134.75	121.28
A07381-1072	72"W x 6 yd Roll	150.82	135.73

Traditional Cotton — Combination weave 100% cotton with a 10 oz pre-primed weight and 14 oz primed weight. Triple acrylic-primed. Medium texture.

NUMBER	SIZE	EACH	6/EA
A07382-6006	60"W x 6 yd Roll	\$221.11	\$198.99
A07382-7206	72"W x 6 yd Roll	273.75	246.38



Blick® Unprimed Belgian Linen & Cotton Canvas Blankets

Prime and stretch your own canvas without the hassle of transporting a large roll! Choose 100% pure Belgian linen or cotton duck in a variety of weights, widths, and sizes.

Medium Texture Cotton — 10 oz unprimed weight.

NUMBER	SIZE	EACH	6/EA
A07333-1060	60"W x 3 yds	\$46.27	\$41.65
A07333-1084	84"W x 3 yds	75.73	68.16

Medium Texture #12 Cotton — Close weave construction. 12 oz unprimed weight.

NUMBER	SIZE	EACH	6/EA
A07333-1254	54"W x 3 yds	\$53.85	\$48.47
A07333-1260	60"W x 3 yds	56.38	50.74
A07333-1272	72"W x 3 yds	63.11	56.80

Medium Texture Belgian Linen — 8.7 oz unprimed weight.

NUMBER	SIZE	EACH	6/EA
A07333-1001	54"W x 1 yd	\$63.11	\$56.80
A07333-1003	54"W x 3 yds	132.54	119.28
A07333-1101	84"W x 1 yd	79.48	71.54
A07333-1103	84"W x 3 yds	176.72	159.05

Portrait-Grade Belgian Linen — Choose 8.85 oz Medium Texture or 6.5 oz Fine Texture.

NUMBER	SIZE	EACH	6/EA
A07333-1201	54"W x 1 yd, Medium	\$63.12	\$56.81
A07333-1203	54"W x 3 yds, Medium	151.53	136.37
A07333-1301	62"W x 1 yd, Fine	67.33	60.59
A07333-1303	62"W x 3 yds, Fine	168.35	151.50

Blick Medium Texture Cotton

Blick Medium Texture #12 Cotton

Blick Medium Texture Belgian Linen

Blick Portrait-Grade Belgian Linen, Fine

BLICK® canvas

Blick® Cotton Canvas By the Yard

Blick Studio Canvas — Identical in quality to Blick Studio stretched canvas, this medium texture 7 oz, 100% cotton duck canvas is triple-primed with acid-free titanium gesso, excellent for painting with oils, acrylics, or alkyds. By the yard.

NUMBER	SIZE	EACH	25/EA
A07341-5225	52"W	\$14.77	\$13.29
A07341-7225	72"W	20.03	18.03

Blick Medium Weight — Our best-selling 100% cotton duck. Unprimed or primed. 7 oz. By the yard.

NUMBER	SIZE	EACH	12/EA
A07309-1062	64-1/2"W, Unprimed	\$7.98	\$7.18
A07309-1063	64-1/2"W, Primed	11.29	10.17

Blick® Premier Unprimed Belgian Linen Canvas

Our top-quality, professional-grade linen canvas is produced in Belgium, where growing conditions and expert cultivation produce the highest-quality, long line fibers. The proprietary weave configurations are produced according to our demanding specifications. All pieces below are shipped folded; longer lengths (up to 50 yards) are available in rolls at DickBlick.com.

Type 66J, Fine Texture — 8.8 oz single weave Belgian linen with a fine texture. Preferred by portrait artists.

NUMBER	SIZE	EACH	6/EA
A07396-5401	54"W x 1 yd Blanket	\$63.62	\$57.27
A07396-5402	54"W x 2 yd Blanket	123.59	111.23
A07396-5404	54"W x 4 yd Blanket	256.64	231.03

Type 144, Smooth Texture — Lightweight, 10.25 oz Belgian linen with a smooth, single weave texture. An excellent general purpose linen.

NUMBER	SIZE	EACH	6/EA
A07393-8401	84" x 1 yd Blanket	\$93.08	\$83.77
A07393-8402	84" x 2 yd blanket	180.14	162.13
A07393-8404	84" x 4 yd blanket	359.00	323.00

Type 185, Smooth Texture — 9.3 oz Belgian linen with a smooth texture. 125" width lets you work on a grand scale.

NUMBER	SIZE	EACH	6/EA
A07394-2501	125"W x 1 yd Blanket	\$128.60	\$115.76
A07394-2502	125"W x 2 yd Blanket	254.45	228.99
A07394-2504	125"W x 4 yd Blanket	501.00	451.00

Blick Studio

Blick Medium Weight

Type 66J

Type 144

Type 185

Fredrix Style 568

Fredrix® Cotton Canvas Rolls

140 years of experience have given Fredrix the knowledge and the tools to create superior canvas of the highest archival quality. Primed options are primed in the USA, which allows for complete control over the process.

Fredrix® Style 568 — Finest 7 oz pure cotton duck. Medium weight. Unprimed rolls.

NUMBER	SIZE	EACH	12/EA
A07303-1352	52"W x 3 yd Roll	\$44.99	\$40.51
A07303-1662	62"W x 6 yd Roll	87.05	78.35

Fredrix Style 70

Fredrix® Style 70 — Finest-quality, pure cotton duck, medium texture, good strength. Popular for all uses. Acrylic-primed rolls. 10.5 oz.

NUMBER	SIZE	EACH	12/EA
A07305-1353	53"W x 3 yd Roll	\$65.17	\$58.65
A07305-1363	53"W x 6 yd Roll	101.03	90.92

Fredrix Style 575

Fredrix® Style 575 Scholastic — A lightweight, polyflax/cotton with a uniform texture. Preferred for detail and commercial work. Acrylic-primed. 9 oz.

NUMBER	SIZE	EACH	6/EA
A07306-1657	57"W x 6 yd Roll	\$78.25	\$70.42

Fredrix Style 122

Fredrix® Style 122 Yankee — A strong, medium-weight cotton duck with excellent tooth. For murals and larger paintings. Acrylic-primed. 11.5 oz.

NUMBER	SIZE	EACH	6/EA
A07312-1073	73"W x 6 yd Roll	\$146.75	\$132.09

Master's

Artists'

Studio Series

Traditional



Richeson® Cast Iron Canvas Pliers

Made of heavy-duty cast iron, they feature 3" wide serrated jaws and a textured, no-slip handle for a secure grip — making it easy for you to achieve a tight, even stretch every time.

NUMBER	EACH	12/EA
A03509-1003	\$16.03	\$14.42



Fredrix® Premier Canvas Pliers

These durable metal canvas pliers are chrome-finished, with a rubber-covered jaw that won't damage your canvas. Rubber handles offer a firm hold while stapling or stretching, turning a two-person job into a one-person job!

NUMBER	EACH	12/EA
A03410-1001	\$32.17	\$28.95

HEALTH & SAFETY ICONS: ●=CL / ■=Prop 65 / ▼=CL & Prop 65
See page 644 for more information.

WARNING! Products marked with a Prop 65 symbol (■ or ▼) can expose you to chemicals, including cadmium, which are known to the State of California to cause cancer and birth defects or other reproductive harm. For more information, visit P65Warnings.ca.gov.

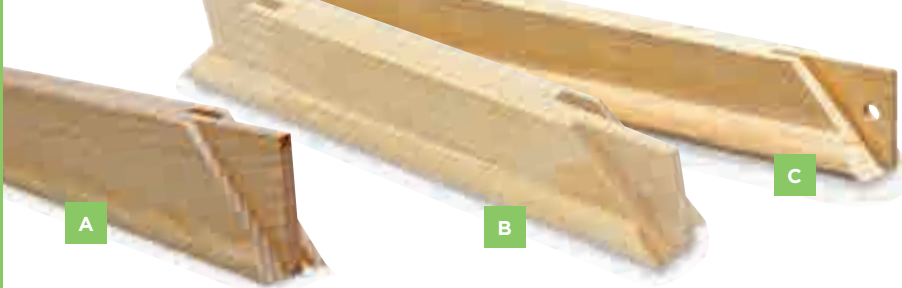

A Utrecht® Heavy-Duty Canvas Stretcher Bars

Ideal for larger works or whenever you need a sturdier frame. The extra-wide strips are made from seasoned, kiln-dried ponderosa pine and hem-fir, beveled on one side. Corners are slotted and double-mortised. 2-1/4" x 1-1/4". Price is per strip, not pair.

NUMBER	SIZE	EACH	12/EA	24/EA
A07226-1010	10"	\$3.85	\$3.47	\$3.29
A07226-1012	12"	3.94	3.55	3.37
A07226-1014	14"	4.50	4.05	3.85
A07226-1016	16"	5.56	4.99	4.75
A07226-1018	18"	9.12	8.21	7.80
A07226-1020	20"	9.77	8.79	8.35
A07226-1022	22"	10.54	9.49	8.99
A07226-1024	24"	11.33	10.20	9.69
A07226-1026	26"	11.74	10.57	10.03
A07226-1028	28"	12.55	11.30	10.73
A07226-1030	30"	13.09	11.78	11.19
A07226-1032	32"	13.25	11.93	11.33
A07226-1034	34"	13.57	12.21	11.60
A07226-1036	36"	14.06	12.65	12.03
A07226-1038	38"	15.06	13.55	12.88
A07226-1040	40"	15.68	14.11	13.41
A07226-1042	42"	15.99	14.42	13.69
A07226-1044	44"	16.25	14.62	13.89
A07226-1046	46"	16.98	15.28	14.52
A07226-1048	48"	17.16	15.44	14.67
A07226-1050	50"	18.59	16.73	15.89
A07226-1052	52"	19.16	17.24	16.38
A07226-1054	54"	19.72	17.75	16.86
A07226-1056	56"	20.28	18.25	17.34
A07226-1058	58"	20.89	18.80	17.86
A07226-1060	60"	21.17	19.05	18.10
A07226-1062	62"	22.79	20.51	19.49
A07226-1064	64"	23.75	21.38	20.31
A07226-1066	66"	24.47	22.02	20.92
A07226-1068	68"	25.45	22.91	21.76
A07226-1070	70"	26.44	23.80	22.61
A07226-1072	72"	26.87	24.18	22.97
A07226-1084	84"	39.86	35.87	34.08
A07226-1096	96"	52.98	47.68	45.30

B BEST™ Heavy-Duty Stretcher Bars

Made of strong, kiln-dried, knot-free pine sourced from FSC-certified suppliers. Each bar's profile has a slightly rounded edge with a 1/2" rise. This prevents sagging and helps eliminate ghost impressions. 2" x 1-1/4". Price is per strip, not pair. For additional sizes, visit DickBlick.com.

NUMBER	SIZE	EACH	12/EA	24/EA
A07230-1008	8"	\$5.06	\$4.54	\$4.33
A07230-1010	10"	5.15	4.62	4.41
A07230-1011	11"	5.38	4.82	4.60
A07230-1012	12"	5.38	4.82	4.60
A07230-1014	14"	5.75	5.15	4.91
A07230-1015	15"	6.57	5.89	5.62
A07230-1016	16"	6.57	5.89	5.62
A07230-1018	18"	6.98	6.25	5.97
A07230-1020	20"	7.80	6.99	6.67
A07230-1022	22"	8.59	7.73	7.34
A07230-1024	24"	9.29	8.36	7.94
A07230-1026	26"	10.83	9.75	9.26
A07230-1028	28"	11.86	10.67	10.13
A07230-1030	30"	12.42	11.17	10.61
A07230-1032	32"	13.58	12.22	11.61
A07230-1035	35"	14.66	13.19	12.53
A07230-1036	36"	14.96	13.46	12.78
A07230-1038	38"	16.23	14.60	13.86
A07230-1040	40"	17.82	16.03	15.22
A07230-1042	42"	18.06	16.24	15.42
A07230-1046	46"	19.46	17.51	16.63
A07230-1048	48"	20.59	18.52	17.59
A07230-1050	50"	22.20	19.97	18.97
A07230-1052	52"	23.24	20.91	19.86
A07230-1060	60"	26.42	23.77	22.58
A07230-1070	70"	31.29	28.15	26.75
A07230-1072	72"	31.29	28.15	26.75
A07230-1090	90"	44.79	40.30	38.26
A07230-1096	96"	64.10	57.67	54.78

C BEST™ Medium-Duty Stretcher Bars

Made from kiln-dried, knot-free, straight white pine. The rounded back edge on these high-quality stretcher bars reduces surface friction and eliminates ghost impressions. 1-1/2"W x 1-1/4"D. Price is per strip, not pair.

NUMBER	LENGTH	EACH	24/EA
A07209-1008	8"	\$3.40	\$2.91
A07209-1010	10"	3.59	3.07
A07209-1012	12"	3.88	3.31
A07209-1014	14"	4.07	3.47
A07209-1016	16"	4.73	4.04
A07209-1018	18"	5.25	4.48
A07209-1020	20"	5.58	4.77
A07209-1024	24"	6.29	5.37
A07209-1028	28"	8.70	7.43
A07209-1030	30"	9.27	7.92
A07209-1036	36"	12.20	10.42
A07209-1040	40"	13.95	11.91
A07209-1041	41"	14.42	12.32
A07209-1042	42"	14.42	12.32
A07209-1043	43"	14.85	12.68
A07209-1048	48"	15.75	13.45
A07209-1049	49"	16.03	13.69
A07209-1050	50"	16.03	13.69
A07209-1053	53"	16.93	14.46
A07209-1054	54"	16.93	14.46
A07209-1057	57"	17.78	15.19
A07209-1060	60"	17.99	15.39
A07209-1061	61"	18.39	15.71
A07209-1063	63"	18.58	15.87
A07209-1067	67"	19.53	16.68
A07209-1069	69"	20.10	17.16

FREE SHIPPING —
Orders of \$49 or more
ship free.



D Blick® Standard Stretcher Bars

Our exclusive Standard Stretchers are made from kiln-dried Brazilian white pine and guaranteed not to warp or bend. Measuring 1-1/2"W x 13/16"D, they are designed with a 1/2" relief to eliminate ghost impressions on your stretched canvas. The rounded edges reduce surface friction and allow for a tighter, more even draw. Corners are slotted and double mortised. Price is per strip, not pair.

NUMBER	LENGTH	EACH	12/EA	24/EA
A07227-1008	8"	\$1.71	\$1.53	\$1.46
A07227-1009	9"	1.75	1.57	1.50
A07227-1010	10"	1.95	1.75	1.66
A07227-1011	11"	2.33	2.09	1.99
A07227-1012	12"	2.33	2.09	1.99
A07227-1013	13"	2.55	2.29	2.18
A07227-1014	14"	2.66	2.38	2.27
A07227-1015	15"	2.80	2.51	2.39
A07227-1016	16"	3.08	2.76	2.63
A07227-1017	17"	3.11	2.79	2.66
A07227-1018	18"	3.15	2.83	2.69
A07227-1019	19"	3.20	2.87	2.73
A07227-1020	20"	3.36	2.99	2.86
A07227-1021	21"	3.36	2.99	2.86
A07227-1022	22"	3.38	3.03	2.87
A07227-1023	23"	3.48	3.13	2.96
A07227-1024	24"	3.52	3.16	2.99
A07227-1025	25"	3.78	3.39	3.21
A07227-1026	26"	3.99	3.60	3.40
A07227-1027	27"	4.27	3.83	3.62
A07227-1028	28"	4.47	3.99	3.83
A07227-1029	29"	4.98	4.47	4.26
A07227-1030	30"	5.20	4.67	4.45
A07227-1031	31"	5.46	4.90	4.67
A07227-1032	32"	5.69	5.11	4.87
A07227-1034	34"	6.43	5.78	5.50
A07227-1036	36"	7.17	6.44	6.14
A07227-1038	38"	7.85	7.05	6.72
A07227-1040	40"	7.98	7.19	6.82
A07227-1042	42"	8.21	7.40	6.99
A07227-1044	44"	9.35	8.43	7.99
A07227-1046	46"	9.41	8.48	8.05
A07227-1048	48"	9.63	8.68	8.24



Fredrix® Standard Stretcher Bar Bulk Packs of 50

Buy in bulk and save! Made of fine, kiln-dried ponderosa pine, these stretcher bars feature tongue-and-groove joinery and are molded on modern woodworking machines to ensure a smooth, tight fit. They are 1-5/8"W x 11/16"D, with a 1/8" tapered edge to eliminate ghost impressions on your stretched canvas.

NUMBER	SIZE	EACH	3/EA
A07234-1008	8"	\$61.07	\$54.99
A07234-1010	10"	67.11	60.44
A07234-1012	12"	68.93	62.07
A07234-1016	16"	95.54	86.03
A07234-1018	18"	108.84	97.99
A07234-1020	20"	116.69	105.08
A07234-1024	24"	129.39	116.52
A07234-1030	30"	191.66	172.60
A07234-1036	36"	244.87	220.52
A07234-1048	48"	376.00	339.00



Blick® Professional Gesso

The frugal professional's best choice. Our exclusive formula offers the highest opacity, tooth, adhesion, and water-resistance, plus the highest concentration of titanium pigment for the brightest white ground. Covers in one coat. 100% pure acrylic polymer emulsion.

NUMBER	DESCRIPTION	EACH	12/EA
A00691-1017	White, Quart	\$33.35	\$29.99
A00691-1019	White, Gallon	68.23	61.39



Liquitex® Acrylic Gesso

Ready-mixed painting ground for any kind of paint on a great variety of surfaces. Covers in one coat.

NUMBER	DESCRIPTION	EACH	12/EA
A00618-1007	White, 946 ml	\$31.65	\$28.48
A00618-0080	White, 1.89 Liter	56.75	51.08
A00618-3009	White, 3.78 Liter	67.50	60.75
A00618-3015	Clear, 946 ml	31.65	28.48
A00618-2009	Clear, 3.78 Liter	67.50	60.75

For more about Liquitex® Gesso, visit DickBlick.com.



Utrecht® Professional Gesso

An exceptional grade of titanium dioxide is combined with an excellent polymer binder for optimal whiteness and covering power. Heavy-bodied formula retains brushstrokes when applied in concentration; self-leveling when applied smoothly. Archivaly sound and acid-free.

NUMBER	DESCRIPTION	EACH	6/EA
A02033-1006	White, 16 oz	\$22.48	\$20.23
A02033-1009	White, Gallon	84.46	75.99



Blick® Artists' Gesso

Offers good opacity, tooth, adhesion, and water-resistance at an economical Blick price. Covers in 1-2 coats. Cleans up with soap and water. For more sizes, visit DickBlick.com.

NUMBER	DESCRIPTION	EACH	12/EA
A00691-1025	White, 8 oz	\$9.96	\$8.97
A00691-1026	White, Pint	13.89	12.50
A00691-1027	White, Quart	21.19	19.07
A00691-1029	White, Gallon	55.53	49.98
A00691-2027	Black, Quart	21.05	18.95



Blick® Master Gesso

The perfect primer for oil and acrylic painting, Blick Master Gesso covers beautifully, dries quickly, and features a lower price tag than most other brands. Offers complete coverage in one coat. Includes a convenient easy-pour handle.

NUMBER	DESCRIPTION	EACH	6/EA
A00683-1001	White, Gallon	\$45.95	\$41.35



Utrecht® Artists' Gesso

Superior brightness and excellent covering properties in an acid-free, medium-bodied formula. Produces a slightly toothed surface that can be sanded to an extra smooth finish for detailed work.

NUMBER	DESCRIPTION	EACH	2/EA
A02032-1006	White, 16 oz	\$12.99	\$11.71
A02032-1009	White, Gallon	64.70	58.23



Blick® Studio Gesso

Bright white Blick Studio Gesso covers beautifully, dries quickly, and features a lower price tag than most other brands. Offers full coverage in two passes.

NUMBER	DESCRIPTION	EACH	4/EA
A00682-1001	White, Gallon	\$38.88	\$34.99



Blickrylic™ Gesso

Apply it as a ground to any surface to improve adherence of Blickrylic and other polymer acrylic paints. Blickrylic Gesso is non-toxic and mixes well with other brands of acrylics.

NUMBER	DESCRIPTION	EACH	12/EA
A00711-1016	White, Pint	\$9.76	\$8.34
A00711-1017	White, Quart	16.59	14.18
A00711-1059	White, Gallon	37.10	31.71



Utrecht® Studio Series™ Gesso

This light-bodied acrylic ground is an economical choice for high-volume use. Provides a slightly toothed surface that is sandable to a smooth finish. Apply three coats to achieve maximum opaque coverage and archival stability.

NUMBER	DESCRIPTION	EACH	6/EA
A02031-1006	White, 16 oz	\$10.31	\$9.27
A02031-1009	White, Gallon	41.75	37.58

understanding paper

Whether you use papers professionally, academically, or for your own enjoyment, the paper you choose is a crucial component in achieving your desired result. The best plan is to learn everything you can about a paper before you buy. Here are some of the things artists look for when choosing papers:

Fiber

Paper is made from a variety of plant sources. Whether the fibers are cotton, linen, flax, jute, hemp, bamboo, rice straw, or rattan, they all provide cellulose fibers or plant cells of varying dimensions. A sheet of paper is basically a thin layer of mingled cellulose fibers. Most commonly, three types of fibers are used to produce papers for drawing and painting: cotton, cellulose, and a combination of fibers.

Cotton papers, made from the longest cotton fibers, are generally considered the highest quality and referred to as 100% cotton rag. Able to withstand heavy erasing, they also resist tearing and wear. High-quality 100% cotton paper can last more than 100 years. However, not all cotton papers are the same. Those made from the lesser-quality, shorter cotton fibers can become fuzzy when reworked.

Cellulose papers are usually made of wood pulp and have a natural acid component that will destroy the paper over time. The more acidic a paper is, the shorter its life expectancy. Buffers can be added to make the paper neutral.

Finish

Manufacturers of watercolor paper typically offer three or more finishes, labeled **rough, cold press, not/cold press, and hot press**.

Rough paper is chosen for its definite texture. It is the natural result when a sheet is allowed to air dry without smoothing or pressing. Rough surface paper is a good choice for transparent watercolors used in a bold and immediate style, as it allows the pigment of color washes to settle into the hollows of the paper. Pastel artists also generally prefer a paper with "tooth" or texture to grab onto the pastel pigment.

Cold Press paper, which is the most popular and versatile, has a slight texture. Handmade papers achieve this by re-pressing a new wet sheet, which smoothes the surface to some degree. Machine-made papers achieve a similar effect by placing the wet sheets between cold metal rollers.

Not/Cold Press: A "Not" sheet means it is "not hot press," and the term is often used instead of cold press.

Hot Press paper is very smooth, made by running a freshly formed sheet through heated metal rollers or plates to smooth out any texture and create a flat, hard, featureless surface. A good choice for highly detailed illustrations, it is also used for printmaking, etching, drafting, sketching, and drawing. Other characteristics come into play with bristol, which is usually available in a plate or vellum finish, in a variety of weights.

Drawing and sketching papers are available in a variety of weights and have surface characteristics that depend on the type of media being used, such as pen-and-ink, pencils, crayons, charcoal, markers, or even light washes.

Size & Absorbency

Sizing is added to make paper more water-resistant. It keeps the paper from absorbing too much moisture or pigment and helps to keep watercolors or inks brilliant. It also keeps lines and edges looking crisp. It is less important for papers used for dry media. Sizing also can factor into a paper's archival qualities — whether it will sustain or deteriorate over time.

Internal sizing is added while the paper pulp is still in a liquid state and is maintained in the matter of the paper.

External, Surface, or Tub sizing is applied to the surface of the paper after the sheet is formed and dried. Some paper is both internally and surface-sized.

Formats & Stretching

Art papers come in a variety of formats, including single sheets, pads or sketchbooks, blocks, rolls, or board-mounted. For watercolor or acrylic painting, it's important to stretch your paper before painting so it stays flat, which also makes a more professional presentation when framed.

Single sheets are a great way to experiment using a small amount of paper. They may require stretching and taping to remain flat if wet media is used.

Pads or Sketchbooks are a convenient way to bring your work wherever you go — a good choice for dry techniques that use minimal amounts of water.

A **Block** is a stack of paper glued or bound together on two or more sides and mounted onto a backing board. A block keeps the paper stretched outdoors. Only one sheet can be used at a time.

Rolls are an economical way to work with your favorite papers.

Paper Weight

Thicker or heavier papers can handle more water or paint without buckling, curling, or falling apart. Traditionally, papers are measured by the **weight in pounds** of one ream, approximately 500 sheets. If a paper comes in different sizes, its weight will vary even though the thickness has not changed. Each sheet would have a weight of 1,114 lb for the ream of paper. Its weight changed due to the size of the sheets, not the paper's thickness, but the paper is still designated as 300 lb.

The inconsistency of this traditional method has led to the use of metric measurements or **grams per square meter** or **gsm**. When paper is measured in gsm, its weight will not change with the size of the sheet. The same 22" x 30" sheet of watercolor paper described above would weigh 640 gsm, meaning that a square meter of this paper would weigh 640 grams. Larger sheets of the same paper, such as a 40" x 60" sheet, would also weigh 640 gsm. While different sizes, the square meter remains constant, as does the thickness.

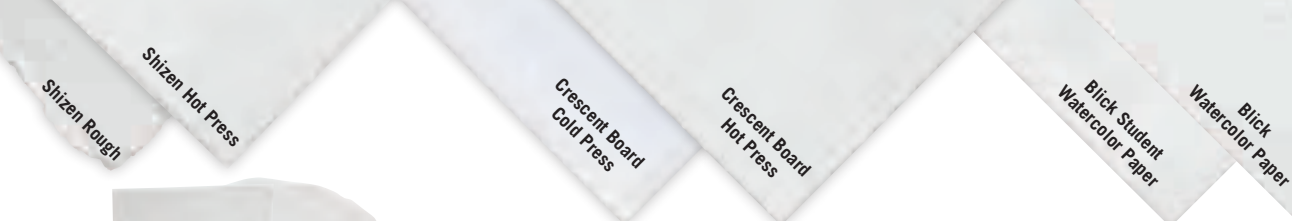

Shizen Professional Watercolor Paper

Shizen paper is handmade in India from 100% recycled materials using a pollution-free process.

This acid-free, 100% cotton, white watercolor paper is both internally and externally sized. The 9" x 12" and 12" x 18" sizes have a heavy deckle edge on four sides. The 5" x 7" has no deckle. 140 lb (300 gsm).

Cold Press Sheet — 22" x 30"

NUMBER	DESCRIPTION	SIZE	EACH	6/EA
A10089-1002			\$4.48	\$4.04

Package of 5

NUMBER	DESCRIPTION	SIZE	EACH	6/EA
A10089-1123	Cold Press	9" x 12"	\$13.42	\$12.08
A10089-1223	Hot Press	9" x 12"	13.42	12.08
A10089-1455	Cold Press	10" x 10"	18.03	16.22
A10089-1355	Hot Press	10" x 10"	18.03	16.22
A10089-1452	Cold Press	12" x 12"	22.11	19.90
A10089-1352	Hot Press	12" x 12"	22.11	19.90
A10089-1106	Cold Press	12" x 18"	17.46	15.72
A10089-1206	Hot Press	12" x 18"	17.46	15.72

Package of 10

NUMBER	DESCRIPTION	SIZE	EACH	6/EA
A10089-2006	Cold Press	6" Round	\$18.99	\$17.09
A10089-2008	Cold Press	8" Round	20.21	18.20

Package of 50

NUMBER	DESCRIPTION	SIZE	EACH	6/EA
A10089-1100	Hot Press	5" x 7"	\$17.35	\$15.61
A10089-1200	Cold Press	5" x 7"	17.35	15.61

Assorted Value Pack — Includes 10 sheets of 12" x 12", 15 Sheets of 10" x 10", 10 sheets of 6" x 6" and 4 sheets of 5" x 7".

NUMBER	DESCRIPTION	EACH	6/EA
A10089-1039	Hot Press	\$29.69	\$26.72

Blick® Student Watercolor Paper

A good quality, economical, white textured paper suitable for student watercolor applications, this paper is also excellent for pencil, pastel, and charcoal. Acid-free and pH-neutral. 90 lb (176 gsm). Not recommended for stretching. Sheets.

NUMBER	SIZE	EACH	50/EA	100/EA
A10028-1028	15" x 22"	\$.65	\$.60	\$.57
A10028-1022	22" x 30"	1.21	1.12	1.06

Blick® Watercolor Paper

This paper has the feel and texture of a fine cold press watercolor paper. Its 140 lb (297 gsm) weight and low price make it one of the best watercolor papers on the market today. Because of its light cold press surface, it's also an excellent paper for all drawing techniques, including pastel and charcoal. Not recommended for stretching. Sheets. Acid-free.

NUMBER	SIZE	EACH	50/EA	100/EA
A10008-1028	15" x 22"	\$1.09	\$.96	\$.92
A10008-1022	22" x 30"	2.25	1.99	1.91

Crescent® Watercolor Boards

This 100% cotton, acid-free, heavyweight (140 lb, 300 gsm) watercolor paper is mounted on one side to an extra-heavy, 1/8" thick, 40-ply acid-free board to eliminate the need for stretching. Excellent for watercolor, acrylics, gouache, illustration, airbrush, and light collage.

Cold Press — 114 Crescent Series.

NUMBER	SIZE	EACH	15/EA
A10005-1015	15" x 20"	\$6.97	\$6.27
A10005-1013	20" x 30"	12.70	11.43
A10005-1016	30" x 40"	24.37	21.93

Hot Press — 115 Crescent Series.

NUMBER	SIZE	EACH	15/EA
A10005-1025	15" x 20"	\$6.97	\$6.27
A10005-1023	20" x 30"	12.70	11.43
A10005-1026	30" x 40"	24.37	21.93

STRATHMORE®



Strathmore® Ready Cut Watercolor Sheets

Ready Cut is Strathmore's 500 Series premium watercolor paper, cut into standard-size sheets. The 100% cotton, archival sheets are lignin-free, acid-free, and available in cold press (CP) and hot press (HP) finishes. 140 lb (300 gsm).

NUMBER	DESCRIPTION	EACH	6/EA
A10094-1000	5" x 7", CP, 25-pack	\$9.98	\$8.98
A10094-1012	8" x 10", CP, 10-pack	9.98	8.98
A10094-1005	11" x 14", CP, 6-pack	9.98	8.98
A10094-2000	5" x 7", HP, 25-pack	9.98	8.98
A10094-2012	8" x 10", HP, 10-pack	9.98	8.98
A10094-2005	11" x 14", HP, 6-pack	9.98	8.98

Strathmore® Imperial® 500 Series Watercolor Paper

A paper of excellent strength, harder sized than "old world" papers, providing greater water hold-out for improved color lifting and blending. Random texture but with uniform performance. Archival quality, 100% cotton fiber, acid-free. Two deckle edges. 140 lb (300 gsm).

Cold Press

NUMBER	SIZE	EACH	25/EA	50/EA
A10006-2002	22" x 30"	\$6.46	\$5.81	\$5.52

Hot Press

NUMBER	SIZE	EACH	25/EA	50/EA
A10006-2012	22" x 30"	\$6.46	\$5.81	\$5.52

Strathmore® 500 Series Aquarius II® Watercolor Paper

Made with an innovative combination of cotton and synthetic fibers that works beautifully with all watercolor techniques. Cold press surface. Acid-free. 80 lb (170 gsm). 22" x 30" sheet.

NUMBER	EACH	10/EA	100/EA
A10019-1002	\$7.12	\$6.41	\$6.09



Blick® Watercolor Pads

Priced for the beginning artist, these economical pads contain 15 sheets of acid-free paper that is ideal for a variety of watercolor techniques. Choose from three sizes of tapebound or spiral-bound pads. Made in the USA.

Essentials, 90 lb (192 gsm)

NUMBER	DESCRIPTION	EACH	12/EA
A10180-1123	9" x 12", Spiral-bound	\$4.40	\$3.97
A10180-1115	11" x 15", Spiral-bound	6.05	5.46
A10180-1109	18" x 24", Spiral-bound	14.35	12.93
A10180-1023	9" x 12", Tapebound	3.75	3.38
A10180-1015	11" x 15", Tapebound	5.58	5.03
A10180-1009	18" x 24", Tapebound	12.99	11.73

Studio, 140 lb (300 gsm)

NUMBER	DESCRIPTION	EACH	12/EA
A10180-1323	9" x 12", Spiral-bound	\$7.99	\$7.19
A10180-1315	11" x 15", Spiral-bound	10.79	9.71
A10180-1309	18" x 24", Spiral-bound	23.84	21.45
A10180-1223	9" x 12", Tapebound	6.29	5.66
A10180-1215	11" x 15", Tapebound	9.09	8.18
A10180-1209	18" x 24", Tapebound	22.04	19.83



Blick® Studio by Fabriano®

This durable, economical, machine-made paper is made from lignin-free 25% cotton and cellulose, with a luxurious handmade feel. Archival, acid-free, and pH-neutral, with internal and external sizing. For watercolors, tempera, gouache, acrylics, inks, and drawing. Choose hot press or cold press. 140 lb (300 gsm).

4-Corner Pack — This unique 20-sheet pack allows easy removal and storage.

NUMBER	DESCRIPTION	EACH	10/EA
A10080-1021	9-1/2" x 13", Cold Press	\$13.57	\$12.20
A10080-1041	13" x 19", Cold Press	27.10	24.39
A10080-1031	9-1/2" x 13", Hot Press	13.57	12.20
A10080-1032	13" x 19", Hot Press	27.10	24.39

10-Sheet Pack — 10 full-sized sheets in a protective plastic bag.

NUMBER	DESCRIPTION	EACH	10/EA
A10080-1022	22" x 30", Cold Press	\$20.63	\$18.56
A10080-1033	22" x 30", Hot Press	20.63	18.56

Richeson® Bulk Watercolor Paper

Great for use in classrooms, studio settings, and for camp and after-school programs, this economical cold press watercolor paper is machine-made from wood pulp. The paper is acid-free, lifts well, features a toothy surface, and has no deckles. Bulk packs of assorted sizes and sheet counts let you order only as much as you need.

88 lb	NUMBER	SIZE	SHEETS	EACH	3/EA
	A09605-1121	6" x 9"	50	\$6.42	\$5.80
	A09605-1123	9" x 12"	50	11.88	10.72
	A09605-1126	12" x 18"	50	19.98	17.97
	A09605-1023	9" x 12"	625	177.11	159.37
	A09605-1005	11" x 14"	350	100.56	90.51
	A09605-1006	12" x 18"	350	195.19	175.65
	A09605-1009	18" x 24"	350	321.00	288.97
	A09605-1147	22-1/2" x 30-1/2"	100	117.77	105.99
135 lb	NUMBER	SIZE	SHEETS	EACH	3/EA
	A09605-1101	6" x 9"	850	\$163.12	\$146.80
	A09605-1103	9" x 12"	425	163.12	146.80
	A09605-1105	11" x 14"	250	99.24	89.31
	A09605-1106	12" x 18"	250	190.43	171.41
	A09605-1109	18" x 24"	200	302.00	271.78
	A09605-1137	22-1/2" x 30-1/2"	100	178.94	161.03



Strathmore® Vision™ Watercolor Pads

The heavyweight, cold press watercolor paper in Vision pads provides even washes and good lifting for all wet media techniques. An economical choice for artists of all skill levels, these spiral-bound pads feature sturdy chipboard backing and a tear-off top sheet that reveals a customizable, 184 lb (300 gsm), steel blue cover. Pads hold 30 sheets of 140 lb (300 gsm) paper, micro-perforated for easy removal. Made in the USA.

NUMBER	SIZE	EACH	6/EA
A09620-1023	9" x 12"	\$7.85	\$7.06
A09620-1015	11" x 15"	12.08	10.93
A09620-1009	18" x 24"	30.14	27.13

Canson® X'L Watercolor Paper Packs

A fine-quality, acid-free, cold press watercolor paper in bulk packs for classroom use. Resistant to repeated washing, it's suitable for all wet techniques — watercolor, gouache, wash, and acrylic. Warm white. 90 lb (185 gsm).

50-Sheet Package

NUMBER	SIZE	EACH	6/EA
A10069-1020	18-1/4" x 24"	\$59.78	\$53.80
A10069-1030	24-1/4" x 36"	113.44	102.10

100-Sheet Package

NUMBER	SIZE	EACH	6/EA
A10081-1033	9" x 12"	\$25.61	\$23.05
A10081-1056	12" x 18"	52.86	47.57
A10069-1021	18-1/4" x 24"	92.60	83.34

500-Sheet Package

NUMBER	SIZE	EACH	6/EA
A10081-1023	9" x 12"	\$116.71	\$105.04
A10081-1046	12" x 18"	254.09	228.68



A Strathmore® 200 Series Watercolor Pads

This watercolor paper has a cold press surface, ideal for working in all waterbased media, including watercolor, tempera, acrylic, gouache, or poster paint. Acid-free. 15 sheets per pad. 90 lb (190 gsm).

NUMBER	SIZE	EACH	12/EA
A10135-1003	9" x 12"	\$4.37	\$3.93
A10135-1025	11" x 15"	7.23	6.51

B Strathmore® 300 Series Watercolor Paper

A heavyweight, 140 lb (300 gsm) paper with a cold press surface to accept a variety of watercolor techniques. Acid-free.

Sheet — 22" x 30".

NUMBER	SIZE	EACH	25/EA	50/EA
A10085-1002		\$2.69	\$2.42	\$2.30

Class Pack — 24 sheets.

NUMBER	SIZE	EACH	12/EA	24/EA
A10085-1023	9" x 12"	\$10.03	\$9.03	\$8.58

Spiral-Bound Pads — 12-sheet pads, bound on the short side.

NUMBER	SIZE	EACH	12/EA	24/EA
A10107-1003	9" x 12"	\$7.33	\$6.60	\$6.27
A10107-1005	11" x 15"	11.36	10.22	9.71
A10107-1009	18" x 24"	19.88	17.89	16.99

Tapebound Pads — 12-sheet pads, bound on the short side.

NUMBER	SIZE	EACH	12/EA	24/EA
A10148-1023	9" x 12"	\$7.33	\$6.60	\$6.27
A10148-1005	11" x 15"	11.72	10.55	9.99
A10148-1029	18" x 24"	27.20	24.48	23.26

C Canson® XL® Watercolor Pads

These student-quality watercolor pads hold 30 sheets of 140 lb (300 gsm) paper for watercolor and mixed media techniques. Their heavyweight fold-over covers are ideal for field work.

NUMBER	SIZE	EACH	12/EA	24/EA
A10173-1023	9" x 12"	\$11.58	\$10.42	\$9.90
A10173-1011	11" x 15"	17.21	15.49	14.72
A10173-1006	12" x 18"	22.77	20.49	19.47
A10173-1009	18" x 24"	40.77	36.69	34.86

D Canson® XL® Wirebound Watercolor Pads

This top-selling pad is now available in a wirebound format. The durable, textured cold press paper stands up to repeated washes and other watercolor techniques, yet also works well with acrylics, pen-and-ink, markers, colored pencils, pencils, charcoal, and pastels. It has a smooth surface on the flip side. Wirebound on the long side, these pads hold 30, 140 lb (300 gsm) sheets that are true size when removed at the micro-perforation.

NUMBER	DESCRIPTION	SIZE	EACH	12/EA	24/EA
A10173-1007	30 Sheets	7" x 10"	\$11.34	\$10.21	\$9.70
A10173-1123	30 Sheets	9" x 12"	15.07	13.56	12.88

E Bienfang® Aquademic Watercolor Paper

This watercolor paper is acid-free and pH neutral with a cold press surface. 90 lb (185 gsm).

Sheets

NUMBER	SIZE	EACH	50/EA	100/EA
A10026-1019	18" x 24"	\$1.04	\$4.92	\$8.87
A10014-1022	22" x 30"	1.76	1.47	1.40

Pads — 15 sheets.

NUMBER	SIZE	EACH	6/EA	12/EA
A10114-1003	9" x 12"	\$5.41	\$4.87	\$4.63
A10114-1005	11" x 15"	7.95	7.15	6.79

F Strathmore® 400 Series Watercolor Paper

A cold press professional surface for intermediate and advanced watercolorists. Acid-free. 140 lb (300 gsm).

Sheets

NUMBER	SIZE	EACH	50/EA	100/EA
A10007-1008	15" x 22"	\$1.11	\$0.99	\$0.92
A10007-1002	22" x 30"	2.68	2.41	2.29

12-Sheet Pads — Spiral-bound on the short side.

NUMBER	SIZE	EACH	12/EA	24/EA
A10118-1012	6" x 12"	\$5.54	\$4.99	\$4.74
A10118-1018	6" x 18"	8.06	7.25	6.89
A10118-1003	9" x 12"	7.99	7.19	6.83
A10118-1005	11" x 15"	13.38	12.04	11.44
A10118-1004	12" x 12"	11.06	9.95	9.55
A10118-1007	12" x 18"	14.14	12.73	12.09
A10118-1008	15" x 22"	17.69	15.92	15.12
A10118-1009	18" x 24"	25.16	22.64	21.51

15-Sheet Blocks

NUMBER	SIZE	EACH	12/EA	24/EA
A10016-1003	9" x 12"	\$17.78	\$15.99	\$15.19
A10016-1005	11" x 15"	22.44	20.20	19.19
A10016-1004	13" x 17"	27.27	24.54	23.31
A10016-1008	15" x 20"	35.42	31.88	30.29
A10016-1009	18" x 24"	43.27	38.94	36.99

42" Wide x 10 yd Roll

NUMBER	SIZE	EACH	6/EA	12/EA
A10007-1042		\$66.08	\$59.47	\$56.50

G Strathmore® 400 Series Watercolor Journals

Available in three sizes, these journals hold multiple sheets of 140 lb (300 gsm), acid-free 400 Series cold press watercolor paper, ideal for fine and even watercolor washes, as well as for lifting and scraping. The paper can also be used for gouache and acrylics.

Hardcover

NUMBER	SIZE	EACH	6/EA
A10184-1055	5-1/2" x 8-1/2" Landscape	\$19.04	\$17.14
A10184-1011	11" x 8-1/2" Portrait	27.52	24.77
A10184-1014	14" x 11" Portrait	35.65	32.08

Softcover

NUMBER	SIZE	EACH	6/EA
A10195-1008	5-1/2" x 8"	\$17.15	\$15.43
A10195-1007	9-3/4" x 7-3/4"	21.68	19.51

H Fluid™ EASY-BLOCK™ Watercolor Paper Blocks

Crafted in small batches at slow speeds, Fluid watercolor paper has the strength and working integrity of more expensive mouldmade papers. Glued on two edges, EASY-BLOCK allows artists to paint right on the block without wetting or stretching the paper. The paper is easily removed when the painting is complete. Blocks contain 15 sheets. Acid-free. 140 lb (300 gsm).

Cold Press

NUMBER	SIZE	EACH	12/EA
A10172-1048	4" x 8"	\$6.20	\$5.58
A10172-1066	6" x 6"	7.06	6.35
A10172-1068	6" x 8"	7.93	7.14
A10172-1912	9" x 12"	13.61	12.25
A10172-1212	12" x 12"	17.57	15.81
A10172-1216	12" x 16"	21.97	19.77
A10172-1824	18" x 24"	42.23	37.99

Hot Press

NUMBER	SIZE	EACH	12/EA
A10172-2046	4" x 6"	\$5.25	\$4.72
A10172-2066	6" x 6"	7.06	6.35
A10172-2068	6" x 8"	7.93	7.14
A10172-2088	8" x 8"	9.65	8.68
A10172-2912	9" x 12"	13.61	12.25
A10172-2121	12" x 12"	17.57	15.81
A10172-2620	16" x 20"	37.31	33.58

I Bienfang® Student Watercolor Paper and Pads

This medium-surface, acid-free, cold press sheet is great for students. Perfect for watercolors, it can also be used for mixed media applications. 140 lb (300 gsm).

Sheets

NUMBER	SIZE	EACH	50/EA	100/EA
A10026-1009	18" x 24"	\$1.28	\$1.05	\$0.99
A10014-1002	22" x 30"	1.83	1.52	1.44

Pads — 15 sheets, tapebound on the short side for easy removal.

NUMBER	SIZE	EACH	6/EA	12/EA
A10115-1023	9" x 12"	\$7.78	\$6.99	\$6.64
A10115-1005	11" x 15"	11.65	10.48	9.96
A10115-1009	18" x 25"	30.09	27.08	25.73

J Grumbacher® Watercolor Pads

This 140 lb (300 gsm) cold press watercolor paper features optimized sizing to ensure good wet and dry lifting. The wirebound pads feature patent-pending "In & Out" pages that allow you to remove sheets from the pad for painting, reworking, scanning, and more, then return them to the pad for transporting and safekeeping. 12-sheet pads.

NUMBER	SIZE	EACH	6/EA
A09624-1010	7" x 10"	\$7.99	\$7.30
A09624-1023	9" x 12"	11.44	10.40
A09624-1005	11" x 15"	11.62	10.54



K Canson® Montval Watercolor Pads & Sheets

Prized for its texture and resistance to repeated washing, this natural white cold press paper is suitable for all wet media techniques, including watercolor, gouache, wash, and acrylic painting. 140 lb (300 gsm).

12-Sheet Pads — Tapebound.

NUMBER	SIZE	EACH	6/EA	12/EA
A10111-1003	9" x 12"	\$7.85	\$7.06	\$6.71
A10111-1005	10" x 15"	10.85	9.76	9.27
A10111-1008	15" x 20"	16.69	14.99	14.24
A10111-1009	18" x 24"	25.19	22.67	21.54

12-Sheet Pads — Wire-bound.

NUMBER	SIZE	EACH	6/EA	12/EA
A10111-1021	5-1/2" x 8-1/2"	\$8.31	\$7.48	\$7.11
A10111-1012	9" x 12"	11.57	10.41	9.89

Sheet

NUMBER	SIZE	EACH	10/EA	100/EA
A10075-1002	22" x 30"	\$3.37	\$3.03	\$2.88

L Canson® Montval Cold Press Watercolor Blocks

A fine-quality, acid-free, mildew-resistant cold press paper. Natural White. 15 sheets. 140 lb (300 gsm).

NUMBER	SIZE	EACH	12/EA	24/EA
A10021-1001	4" x 6"	\$9.42	\$8.48	\$8.06
A10021-1011	6" x 9"	12.86	11.57	10.99
A10021-1003	9" x 12"	18.46	16.61	15.78
A10021-1006	12" x 16"	32.21	28.99	27.54
A10021-1008	15" x 20"	41.79	37.61	35.73

M Canson® Plein Air Watercolor Artboards

The perfect substrate for the field or studio, Canson Plein Air Watercolor Artboards are rigid, acid-free, 1.5 mm boards that have been laminated to 128 lb (190 gsm) cold press Canson paper. Glued on one side, the 10-sheet pads have a convenient foldover cover.

NUMBER	SIZE	EACH	6/EA
A09611-1012	8" x 10"	\$13.61	\$12.25
A09611-1023	9" x 12"	15.99	14.39
A09611-1006	12" x 16"	26.47	23.82

N Canson® Artist Series Watercolor Book

These books feature Canson's mouldmade Montval cold press watercolor paper, which performs beautifully with all wet media. Wirebound books hold 20 sheets of heavyweight 140 lb (300 gsm) true size paper, micro-perforated for easy removal. The surface withstands scraping, erasing, and repeated washes. Acid-free and archival. Includes a removable half sheet/bookmark with tips and techniques from some of the most noted artists of the day.

NUMBER	SIZE	EACH	6/EA
A09608-1058	5-1/2" x 8-1/2"	\$10.24	\$9.22
A09608-1023	9" x 12"	16.63	14.97

When ordering sheets of paper or board larger than 18" x 24", a handling fee may apply. See page 648.

L'Aquarelle Canson® Héritage Watercolor Paper

From the first application of watercolor to the last, this paper offers excellent color laydown, brush-to-paper responsiveness, and lifting ease. Made from 100% cotton on a traditional cylinder mould, it possesses superior absorbency and strength. Next-generation, gelatin-free sizing makes corrections easy.

Blocks — 20 sheets, 140 lb (300 gsm).

NUMBER	DESCRIPTION	SIZE	EACH	12/EA
A09616-1027	Cold Press	7" x 10"	\$42.95	\$38.65
A09616-1033	Cold Press	9" x 12"	50.43	45.39
A09616-1043	Hot Press	9" x 12"	50.43	45.39
A09616-1053	Rough	9" x 12"	50.43	45.39
A09616-1034	Cold Press	10" x 14"	63.45	57.10
A09616-1044	Hot Press	10" x 14"	63.45	57.10
A09616-1054	Rough	10" x 14"	63.45	57.10
A09616-1036	Cold Press	12" x 16"	76.99	69.29
A09616-1046	Hot Press	12" x 16"	76.99	69.29
A09616-1056	Rough	12" x 16"	76.99	69.29
A09616-1032	Cold Press	14" x 20"	99.67	89.70
A09616-1042	Hot Press	14" x 20"	99.67	89.70
A09616-1052	Rough	14" x 20"	99.67	89.70
A09616-1039	Cold Press	18" x 24"	140.53	126.48

Pads — 12 sheets, 140 lb (300 gsm).

NUMBER	DESCRIPTION	SIZE	EACH	12/EA
A09616-1003	Cold Press	9" x 12"	\$22.48	\$20.23
A09616-1013	Hot Press	9" x 12"	22.48	20.23
A09616-1023	Rough	9" x 12"	22.48	20.23
A09616-1004	Cold Press	10" x 14"	30.30	27.27
A09616-1014	Hot Press	10" x 14"	30.30	27.27
A09616-1024	Rough	10" x 14"	30.30	27.27

Sheets — 140 lb (300 gsm), 22" x 30".

NUMBER	DESCRIPTION	EACH	1
--------	-------------	------	---



Blick® Premier Watercolor Paper

This professional-quality paper is made on a traditional cylinder mould in a European mill that has been making paper since the 1700s. Both internally and externally sized, its surface is created using natural woolen felts, helping it withstand scrubbing and other wet techniques without tearing. Ideal for watercolors, gouache, inks, and acrylics, this paper is 100% cotton, acid-free, and archival. The blocks are great for painting on location — no soaking required. 140 lb (300 gsm).

Blocks — 20 sheets, glued on all four sides.

NUMBER	SIZE	PRESS	EACH	10/EA
A09619-1010	7" x 10"	Cold	\$26.94	\$24.25
A09619-1110	7" x 10"	Hot	26.94	24.25
A09619-1023	9" x 12"	Cold	33.59	30.23
A09619-1123	9" x 12"	Hot	33.59	30.23
A09619-1004	10" x 14"	Cold	39.35	35.41
A09619-1104	10" x 14"	Hot	39.35	35.41
A09619-1006	12" x 16"	Cold	44.53	40.08
A09619-1106	12" x 16"	Hot	44.53	40.08
A09619-1014	14" x 20"	Cold	72.30	65.07
A09619-1114	14" x 20"	Hot	72.30	65.07
A09619-1009	18" x 24"	Cold	89.53	80.59
A09619-1109	18" x 24"	Hot	89.53	80.59

Sheets — 22" x 30".

NUMBER	DESCRIPTION	PRESS	EACH	10/EA
A09618-1002	Each	Cold	\$5.82	\$5.24
A09618-1202	Each	Hot	5.82	5.24
A09618-1102	Pkg of 5	Cold	29.06	26.15

Fabriano® Artístico Traditional White Sheets and Rolls

These traditional warm white sheets are 22" x 30" with two natural deckles and two cut edges. Mouldmade of 100% cotton. Acid-free.

90 lb (200 gsm) Sheets

NUMBER	PRESS	EACH	10/EA	20/EA
A10061-2022	Cold	\$6.29	\$5.66	\$5.38
A10061-2012	Hot	6.29	5.66	5.38
A10061-2032	Rough	6.29	5.66	5.38

140 lb (300 gsm) Sheets

NUMBER	PRESS	EACH	10/EA	20/EA
A10061-2052	Cold	\$8.67	\$7.80	\$7.31
A10061-2042	Hot	8.67	7.80	7.31
A10061-2062	Rough	8.67	7.80	7.31

300 lb (640 gsm) Sheets

NUMBER	PRESS	EACH	10/EA	20/EA
A10061-2072	Cold	\$19.32	\$17.41	\$16.58
A10061-2082	Hot	19.32	17.41	16.58
A10061-2092	Rough	19.32	17.41	16.58

55" x 10 yd Rolls, 140 lb (300 gsm)

NUMBER	PRESS	EACH	2/EA
A10061-1020	Cold	\$248.25	\$223.42
A10061-1010	Hot	248.25	223.42
A10061-1030	Rough	248.25	223.42

Fabriano® Artístico Extra White Sheets and Rolls

This brilliant white sheet is made naturally without the use of optical brighteners. Sheets are 22" x 30" with two natural deckles and two cut edges.

140 lb (300 gsm) Sheets

NUMBER	PRESS	EACH	10/EA	50/EA
A10062-2032	Cold	\$8.67	\$7.80	\$7.41
A10062-2012	Hot	8.67	7.80	7.41
A10062-2022	Soft	8.67	7.80	7.41
A10062-2042	Rough	8.67	7.80	7.41

300 lb (640 gsm) Sheets

NUMBER	PRESS	EACH	10/EA	50/EA
A10062-2072	Cold	\$19.32	\$17.41	\$16.58
A10062-2052	Hot	19.32	17.41	16.58
A10062-2062	Soft	19.32	17.41	16.58
A10062-2082	Rough	19.32	17.41	16.58

55" x 11 yd Rolls, 140 lb (300 gsm)

NUMBER	PRESS	EACH	2/EA
A10062-1030	Cold	\$244.54	\$220.09
A10062-1010	Hot	244.54	220.09
A10062-1020	Soft	244.54	220.09
A10062-1040	Rough	244.54	220.09



A Fabriano® Artístico Traditional White Blocks

Glued on four sides, perfect for plein air painting. 140 lb (300 gsm).

NUMBER	SIZE	PRESS	SHEETS	EACH	3/EA
A10143-1110	5" x 7"	Cold	25	\$21.43	\$19.48
A10143-1120	5" x 7"	Hot	25	21.43	19.48
A10143-1130	5" x 7"	Rough	25	21.43	19.48
A10143-1103	9" x 12"	Cold	20	36.56	33.24
A10143-1113	9" x 12"	Hot	20	36.56	33.24
A10143-1113	9" x 12"	Rough	20	36.56	33.24
A10143-1123	9" x 12"	Cold	20	59.86	54.42
A10143-1106	12" x 18"	Cold	20	59.86	54.42
A10143-1116	12" x 18"	Hot	20	59.86	54.42
A10143-1126	12" x 18"	Rough	20	59.86	54.42
A10143-1107	14" x 20"	Cold	15	59.86	54.42
A10143-1117	14" x 20"	Hot	15	59.86	54.42
A10143-1127	14" x 20"	Rough	15	59.86	54.42
A10143-1109	18" x 24"	Cold	10	59.86	54.42
A10143-1119	18" x 24"	Hot	10	59.86	54.42
A10143-1129	18" x 24"	Rough	10	59.86	54.42

B Fabriano® Artístico Bright White Blocks

Same exciting Bright White paper in a convenient block. Available in cold, hot, and rough grain. 140 lb (300 gsm).

NUMBER	SIZE	PRESS	SHEETS	EACH	3/EA
A10144-1040	5" x 7"	Cold	25	\$21.43	\$19.48
A10144-1050	5" x 7"	Hot	25	21.43	19.48
A10144-1060	5" x 7"	Rough	25	21.43	19.48
A10144-1043	9" x 12"	Cold	20	36.56	33.24
A10144-1053	9" x 12"	Hot	20	36.56	33.24
A10144-1063	9" x 12"	Rough	20	36.56	33.24
A10144-1046	12" x 18"	Cold	20	59.86	54.42
A10144-1056	12" x 18"	Hot	20	59.86	54.42
A10144-1066	12" x 18"	Rough	20	59.86	54.42
A10144-1047	14" x 20"	Cold	15	59.86	54.42
A10144-1057	14" x 20"	Hot	15	59.86	54.42
A10144-1067	14" x 20"	Rough	15	59.86	54.42



C-D Fabriano® Studio Watercolor Pads and Packs

Now available in frame-ready sizes, Fabriano Studio Watercolor Pads and Packs are priced for students and beginners yet contain what feels like a professional-grade paper. Improved cotton content, professional internal/external sizing, and slower production speeds result in a smooth surface that is available in either cold press or hot press, ideal for watercolors, gouache, acrylics, ink, charcoal, mixed media, and greeting cards. Machine-made from 25% cotton and 75% alpha cellulose.

90 lb (200 gsm), 20 Sheets

NUMBER	SIZE	PRESS	EACH	6/EA
A10145-1002 C	8" x 10"	Cold	\$7.05	\$6.35
A10145-2020	9" x 12"	Cold	9.03	8.13
A10145-2120	11" x 14"	Cold	12.75	11.47

90 lb (200 gsm), 75 Sheets

NUMBER	SIZE	PRESS	EACH	6/EA
A10145-2075	9" x 12"	Cold	\$35.42	\$31.88
A10145-3075 D	9" x 12"	Hot	35.42	31.88
A10145-2175	11" x 14"	Cold	43.67	39.30
A10145-3175	11" x 14"	Hot	43.67	39.30

140 lb (300 gsm), 12 Sheets

NUMBER	SIZE	PRESS	EACH	6/EA
A10145-1003	8" x 10"	Cold	\$7.05	\$6.35
A10145-2012	9" x 12"	Cold	9.03	8.13
A10145-2112	11" x 14"	Cold	12.75	11.47

140 lb (300 gsm), 50 Sheets

NUMBER	SIZE	PRESS	EACH	6/EA
A10145-2050	9" x 12"	Cold	\$35.42	\$31.88
A10145-3050	9" x 12"	Hot	35.42	31.88
A10145-2150	11" x 14"	Cold	43.67	39.30
A10145-3150	11" x 14"	Hot	43.67	39.30

Sheets — 90 lb (200 gsm), 100 sheets.

NUMBER	SIZE	PRESS	EACH	6/EA
A09629-1023	9" x 12"	Cold	\$35.74	\$32.16
A09629-1006	12" x 18"	Cold	64.47	57.99



Fabriano® Studio Cold Press Paper

The papermakers at Fabriano realize that students can't afford premium papers but need the quality in order to learn proper technique. Created from 25% cotton and lignin-free cellulose, this economical, high-quality, acid-free paper is internally and externally sized, perfect for the emerging artist.

90 lb (200 gsm) Sheets

NUMBER	SIZE	PRESS	EACH	10/EA
A10063-1010	19-1/2" x 27-1/2"	Cold	\$2.11	\$1.90

140 lb (300 gsm) Sheets

NUMBER	SIZE	PRESS	EACH	10/EA
A10063-1020	19-1/2" x 27-1/2"	Cold	\$2.31	\$2.09
A10063-1050	29-1/2" x 42"	Cold	5.08	4.57
A10063-1030	22" x 30"	Cold	3.03	2.73
A10063-1080	22" x 30"	Hot	3.03	2.73

140 lb (300 gsm) Roll

NUMBER	SIZE	PRESS	EACH	4/EA
A10063-1060	59" x 394"	Cold	\$169.59	\$154.95



Arches® Watercolor Pads

Perfect for plein air painting and convenient for travel, Arches Watercolor Pads are ideal for both professional artists and students. Each pad holds 12 sheets of natural white, 100% cotton, acid-free paper. The paper is ideal for watercolor, gouache, ink, acrylics, drawing, and printmaking, and strong enough to handle multiple washes of color, masking fluid, scrubbing, and artist's tape without damage to the surface. Gelatin sizing gives each fiber a consistent feel and absorbency. A long-time favorite of artists, Arches watercolor paper is produced on a cylinder mould machine and has been manufactured in the same French paper mill since 1492. 140 lb (300 gsm).

Euro Fold

NUMBER	DESCRIPTION	SIZE	EACH	6/EA	12/EA
A10183-1009	Cold Press	9" x 12"	\$24.38	\$21.94	\$20.84
A10183-2009	Rough	9" x 12"	24.38	21.94	20.84
A10183-3009	Hot Press	9" x 12"	24.38	21.94	20.84
A10183-1010	Cold Press	10" x 14"	25.47	22.92	21.77
A10183-2010	Rough	10" x 14"	25.47	22.92	21.77
A10183-3010	Hot Press	10" x 14"	25.47	22.92	21.77



Hahnemühle Harmony Watercolor Pads

This natural white paper is ideal for all wet painting techniques, with surface sizing that allows colors to be lifted or corrected easily. Colors stand out well and masking fluids, masking tape, and erasers can be used without damaging or leaving residue on the surface. Acid-free, lignin-free, archival, and light-resistant. 12-sheet pads. 140 lb (300 gsm).

Cold Press

NUMBER	SIZE	EACH	6/EA	12/EA
A09637-1001	8.27" x 11.69"	\$16.99	\$15.29	\$14.53
A09637-1002	11.7" x 15.5"	23.34	20.99	19.94

Hot Press

NUMBER	SIZE	EACH	6/EA	12/EA
A09637-1003	8.27" x 11.69"	\$16.99	\$15.29	\$14.53
A09637-1004	11.7" x 15.5"	23.34	20.99	19.94

When ordering sheets of paper or board larger than 18" x 24", a handling fee may apply. See page 648.



Arches® Natural White 140 lb Watercolor Blocks

Arches Watercolor Blocks contain traditional mouldmade, 100% cotton, natural white paper. The pH-neutral, gelatin-sized sheets are glued on four sides, eliminating the need to stretch the paper prior to painting. Great for working in the field or on location. All papers are 140 lb (300 gsm) weight.

Cold Press — 140 lb (300 gsm). 20 sheets per block.

NUMBER	SIZE	EACH	6/EA	12/EA
A10020-1002	8" x 10"	\$43.64	\$39.28	\$37.32
A10020-1003	9" x 12"	47.11	42.40	40.28
A10020-1040	10" x 14"	56.75	51.07	48.52
A10020-1004	11" x 14"	62.84	56.56	53.73
A10020-1005	12" x 12"	66.06	59.45	56.48
A10020-1060	12" x 16"	66.48	59.83	56.84
A10020-1008	14" x 20"	88.03	79.23	75.27
A10020-1006	16" x 20"	92.04	82.84	78.70
A10020-1009	18" x 24"	118.99	107.09	101.74

Hot Press — 140 lb (300 gsm). 20 sheets per block.

NUMBER	SIZE	EACH	6/EA	12/EA
A10020-1012	8" x 10"	\$43.64	\$39.28	\$37.32
A10020-1013	9" x 12"	47.11	42.40	40.28
A10020-1041				

**A Blick® Liquid Frisket**

Fluorescent orange masking fluid for use on watercolor papers, photos, and other applications where overlying applications of watercolors, gouache, or ink are to be made. Apply to sized paper, then remove by peeling or rubbing with a soft eraser. Remove within 24–48 hours for best results. Product contains latex.

NUMBER	SIZE	EACH	6/EA
A01730-1003	1.2 oz (35 ml)	\$9.99	\$8.99

B Winsor & Newton™ Masking Fluids

Colorless Art Masking Fluid — A removable colorless liquid for masking areas of work needing protection when color is applied in broad washes. Specifically designed for soft-sized papers to avoid staining. Made from rubber and latex/pigment. Glass bottle.

NUMBER	SIZE	EACH	6/EA
A00346-2104	2.54 oz (75 ml)	\$12.46	\$11.21

Permanent Masking Medium — A non-removable, transparent liquid mask, excellent for detail. Can be applied directly onto the paper or mixed with watercolors first. Ensure that fluid is thoroughly dry before overpainting. Wash brushes in warm soapy water before using other colors. Contains latex. Glass bottle.

NUMBER	SIZE	EACH	6/EA
A00346-9004	2.54 oz (75 ml)	\$6.82	\$6.13

**Grafix® Incredible White Mask™**

A high-quality, non-pigmented liquid frisket for watercolor masking. Dries to a neutral cream color and shows through dry paint so you can see exactly where you've masked. Product contains latex.

NUMBER	SIZE	EACH	6/EA
A00312-1002	2 oz (60 ml)	\$11.33	\$10.20
A00312-1004	4.5 oz (120 ml)	15.12	13.61

Incredible Nib Liquid Frisket Kit — Kit includes the Incredible Nib, a bottle of the Incredible White Mask, a Liquid Frisket Remover Tool, and a "Tips and Techniques" pamphlet. Product contains latex.

NUMBER	SIZE	EACH	6/EA
A00312-1102	2 oz (60 ml)	\$20.07	\$18.06
A00312-1045	4 oz (120 ml)	31.71	28.54
A02902-0002	8.5 oz (250 ml)	38.84	34.96

**C–E Pebeo® Drawing Gum**

A peelable, gray rubber solution for watercolor and airbrush masking. Dilutes with water. Plastic bottles.

NUMBER	SIZE	EACH	5/EA
A00364-1045	1.52 oz (45 ml)	\$9.32	\$8.40
A00364-1250	8.5 oz (250 ml)	28.64	25.78
A00364-1010	Marker	9.54	8.59

E Drawing Gum Marker for Kids — Lightly tinted masking fluid formula in a children's size marker. Quick-drying with a 4 mm round tip, it can be used to draw designs on paper, cardboard, and more.

NUMBER	SIZE	EACH	5/EA
A00848-1004		\$7.73	\$6.95

Grumbacher® Miskit™ Frisket

For use on hard-sized watercolor papers and photos in areas that are meant to be painted once the dried Frisket is removed.

Fluorescent Orange. Contains latex. Glass jar.

NUMBER	SIZE	EACH	6/EA
A00317-0030	1.2 oz (35 ml)	\$11.13	\$10.41

**Masquepen® Art Masking Fluid**

Blue masque fluid is easy to see. Use the unique applicator as a pen on areas where color is not wanted. Close after use by inserting applicator prong into a nylon nib. Contains latex.

NUMBER	SIZE	EACH	12/EA
A00356-0000	1 oz (30 ml)	\$15.14	\$13.63

Masquepen Refills and Sets — Draw thick, thin, or straight lines, or curves. The pale blue waterbased latex solution is easy to see and apply, and it peels away from paper like a charm. For set contents, visit DickBlick.com.

NUMBER	DESCRIPTION	EACH	12/EA
A00356-1001	1 oz Refill	\$8.63	\$7.77
A00356-1002	Supernib Attachment	15.24	13.72
A00356-1010	Small Set	28.97	26.07
A00356-1020	Large Set	37.23	33.51

F Grafix® Incredible Nib®

Designed for precise application of masking fluid, and for control in lifting, correcting, blending, softening, and creating hard edges and perfectly straight lines. The fiber tips stay firm when wet. Clean nibs with soap and water or in the dishwasher.

NUMBER	EACH	6/EA
A02902-0001	\$11.27	\$10.14

G Grafix® Incredible Nib® Broad

This version of the Incredible Nib has a sharp point on one end and a 1/4" diameter round wedge on the other.

NUMBER	EACH	6/EA
A02902-0000	\$11.27	\$10.14

**Shiva® Liquid Masque™**

For watercolor and airbrush masking. Paint as desired; when dry, remove film by peeling or rubbing. Contains latex. Use Cleaner for cleaning brushes. 3.75 oz (112 ml) glass bottles.

NUMBER	DESCRIPTION	EACH	12/EA
A00313-1014	Masque	\$12.32	\$11.07
A00313-1004	Cleaner	9.73	8.75

**Scotch® Artist Tape for Watercolor Paper**

Designed especially to stick securely for creating hard paint lines, yet it will remove easily without damaging paper surfaces. White.

NUMBER	SIZE	EACH	12/EA
A24109-1001	3/4"W x 10 yd Roll	\$5.30	\$4.79

Dr. Ph. Martin's® Frisket Mask Liquid

A safer liquid frisket that's waterbased and certified non-toxic. Seals well on almost any surface, does not stain, and peels off cleanly. The bottle includes an eyedropper lid for easy application.

NUMBER	SIZE	EACH	12/EA
A00344-9000	1 oz (30 ml)	\$12.12	\$10.91

HEALTH & SAFETY ICONS: ●=CL / ■=Prop 65 / ▼=CL & Prop 65
See page 644 for more information.

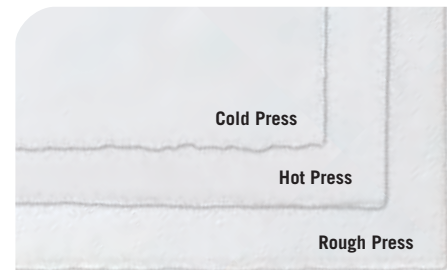
**Lanaquarelle™ Watercolor Paper**

Since 1590, the Lana mill has been supplying European watercolorists with the finest papers. Lanaquarelle is made on a cylinder mould machine, giving it the look and feel of a handmade paper but with better consistency. 100% cotton, neutral pH. Sheets have two tear deckles and two natural deckles.

Cold Press Sheet — 22" x 30".

NUMBER	WEIGHT	EACH	10/EA
A10015-1002	140 lb (300 gsm)	\$10.85	\$9.76
A10015-1012	300 lb (638 gsm)	22.03	19.83

Hot Press Sheet — 22" x 30".

NUMBER	WEIGHT	EACH	10/EA
A10015-1022	140 lb (300 gsm)	\$10.85	\$9.76
A10015-1032	300 lb (638 gsm)	22.03	19.83

Rough Sheet — 22" x 30".

NUMBER	WEIGHT	EACH	10/EA
A10015-1052	140 lb (300 gsm)	\$10.85	\$9.76
A10015-1062	300 lb (638 gsm)	22.03	19.83

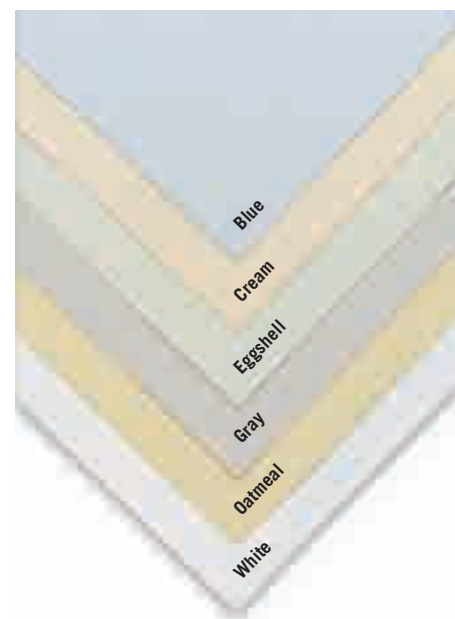
**Bockingford® Tinted Paper**

The fine quality of Bockingford tinted paper offers artists a unique environment for watercolor painting. The transparent nature of watercolor makes paper a vital part of the finished look and the addition of a colored background is an ideal way of adding atmosphere to your paintings. This mouldmade, 100% alpha cellulose sheet has an archival neutral pH and is available in six lightfast colors. This paper is also perfect for a wide range of painting and drawing media. 22" x 30" sheets. 140 lb (300 gsm).

NUMBER	COLOR	EACH	25/EA
A10079-5012	Blue	\$5.98	\$5.38
A10079-1102	Cream	5.98	5.38
A10079-1252	Eggshell	5.98	5.38
A10079-2222	Gray	5.98	5.38
A10079-1122	Oatmeal	5.98	5.38
A10079-1022	White	5.98	5.38

**Lanaquarelle™ Watercolor Blocks**

Blocks are bound on all four sides.

Cold Press Block — 20 sheets, 140 lb (300 gsm).

NUMBER	SIZE	EACH	12/EA
A10125-1009	7" x 10"	\$30.33	\$27.30
A10125-1003	9" x 12"	45.43	40.89
A10125-1004	10" x 14"	57.73	51.96
A10125-1006	12" x 16"	68.45	61.60
A10125-1008	14" x 20"	88.57	79.71

Hot Press Block — 20 sheets, 140 lb (300 gsm).

NUMBER	SIZE	EACH	12/EA
A10125-1010	7" x 10"	\$30.33	\$27.30
A10125-1013	9" x 12"	45.43	40.89
A10125-1017	12" x 16"	68.45	61.60
A10125-1018	14" x 20"	88.57	79.71

**Bee® Watercolor Paper**

This professional-quality paper is versatile and receptive to all watercolor techniques. The sheets feature a well-sized, cold press surface that is archival, pH-neutral, and maintains maximum strength when wet. 140 lb (300 gsm).

NUMBER	SIZE	EACH	12/EA
A10092-1023	9" x 12"	\$10.48	\$9.43
A10092-1011	11" x 15"	14.93	13.44

50-Sheet Pack

NUMBER	SIZE	EACH	12/EA
A09606-1069	6" x 9"	\$26.95	\$24.25

**Incredible Art Board™**

The Incredible Art Board is great for stretching watercolor paper because it won't bend, buckle, or warp. It has a smooth surface for mounting paper, prints, and photos. The feather-light material is very durable, water-resistant, and will accept repeated stapling and taping.

NUMBER	SIZE	EACH	6/EA	12/EA
A12950-1009	16" x 24"	\$25.12	\$22.61	\$21.48
A12950-1003	24" x 32"	47.08	42.37	40.25

LANAQUARELLE™

Hot Press Block — 20 sheets, 140 lb (300 gsm).

NUMBER	SIZE	EACH	12/EA
A10125-1010	7" x 10"	\$30.33	\$27.30
A10125-1012	9" x 12"	45.43	40.89
A10125-1014	10" x 14"	57.73	51.96
A10125-1015	12" x 16"	68.45	61.60
A10125-1016	14" x 20"	88.57	79.71

Rough Block — 20 sheets, 140 lb (300 gsm).

NUMBER	SIZE	EACH	12/EA
A10125-1002	7" x 10"	\$30.33	\$27.30
A10125-1013	9" x 12"	45.43	40.89
A10125-1017	12" x 16"	68.45	61.60
A10125-1018	14" x 20"	88.57	79.71

Cold Press Block — 20 sheets, 140 lb (300 gsm).

NUMBER	SIZE	EACH	12/EA
A10125-1009	7" x 10"	\$30.33	\$27.30
A10125-1003	9" x 12"	45.43	40.89
A10125-1004	10" x 14"	57.73	51.96
A10125-1006	12" x 16"	68.45	61.60
A10125-1008	14" x 20"	88.57	79.71

Hot Press Block — 20 sheets, 140 lb (300 gsm).

NUMBER	SIZE	EACH	12/EA
A10125-1010	7" x 10"	\$30.33	\$27.30
A10125-1013	9" x 12"	45.43	40.89
A10125-1017	12" x 16"	68.45	61.60
A10125-1018	14" x 20"	88.57	79.71

Cold Press Block — 20 sheets, 140 lb (300 gsm).

NUMBER	SIZE	EACH	12/EA
A10125-1009	7" x 10"	\$30.33	\$27.30
A10125-1003	9" x 12"	45.43	40.89
A10125-1004	10" x 14"	57.73	51.96
A10125-1006	12" x 16"	68.45	61.60
A10125-1008	14" x 20"	88.57	79.71

**Saunders Waterford® Papers**

Professionals the world over love these papers for their superb performance and resistance to distortion. Mouldmade of 100% cotton, Saunders Waterford is gelatin-sized and pH-neutral. Sheets have two natural deckle edges and two torn edges.

Endorsed by the prestigious Royal Watercolour Society of England.

White 22" x 30"

NUMBER	DESCRIPTION	EACH	10/EA
A10059-1190	90 lb (190 gsm), Hot Press	\$7.46	\$6.21
A10059-1090	90 lb (190 gsm), Cold Press	7.46	6.21
A10059-2900	90 lb (190 gsm), Rough	7.46	6.21
A10059-1410	140 lb (300 gsm), Hot Press	10.66	9.59
A10059-1400	140 lb (300 gsm), Cold Press	10.66	9.59
A10059-2910	140 lb (300 gsm), Rough	10.66	9.59
A10059-1210	200 lb (425 gsm), Hot Press	15.62	14.06
A10059-1200	200 lb (425 gsm), Cold Press	15.62	14.06
A10059-1300	300 lb (640 gsm), Cold Press	21.09	18.98
A10059-2930	300 lb (640 gsm), Rough	21.09	18.98

High White 22" x 30"

NUMBER	DESCRIPTION	EACH	10/EA
A10059-2710	140 lb (300 gsm), Hot Press	\$10.66	\$9.59
A10059-2700	140 lb (300 gsm), Cold Press	10.66	9.59
A10059-2720	140 lb (300 gsm), Rough	10.66	9.59

Blocks — 140lb (300gsm)

NUMBER	DESCRIPTION	EACH	10/EA
A10059-1107	7" x 10", Cold Press	\$44.19	\$39.77
A10059-1007	7" x 10", Hot Press	44.19	39.77
A10059-2023	9" x 12", Cold Press	42.05	37.84
A10059-2013	9" x 12", Hot Press	42.05	37.84
A10059-1104	10" x 14", Cold Press	65.23	58.71
A10059			

Yupo® Synthetic Paper

Machine-made from 100% polypropylene, this ultra-bright, pH-neutral, flawlessly smooth "paper" doesn't absorb water, which allows the sheet to lie flat — no soaking, stretching, or taping required! It won't tear or buckle, and it withstands heavy erasing and wiping. Use it for creating unique watercolor effects. It also works well with acrylics and other paints, and for drawing, silk screening, and debossing.

Pads — 74 lb (200 gsm). 10 sheets.

NUMBER	SIZE	EACH	12/EA	24/EA
A10149-1000	5" x 7"	\$6.66	\$5.98	\$5.68
A10149-1023	9" x 12"	17.27	15.76	14.97
A10149-1005	11" x 14"	24.49	22.18	21.07

20" x 26" Sheets

NUMBER	WEIGHT	EACH	10/EA	25/EA
A10067-1021	74 lb (200 gsm)	\$4.58	\$4.12	\$3.91
A10067-1022	144 lb (390 gsm)	8.56	7.72	7.34

26" x 40" Sheets

NUMBER	WEIGHT	EACH	10/EA	25/EA
A10067-1031	74 lb (200 gsm)	\$9.95	\$8.95	\$8.50
A10067-1032	144 lb (390 gsm)	12.46	11.21	10.65

60" x 10 yd Roll

NUMBER	WEIGHT	EACH	10/EA	25/EA
A10067-1040	74 lb (200 gsm)	\$171.57	\$154.41	\$146.69

Yupo® Translucent Synthetic Paper

This translucent sheet offers the same unique properties of Yupo but allows for special layered effects and easy tracing. 104 lb weight.

NUMBER	SIZE	EACH	6/EA	12/EA
A10162-1000	5" x 7"	\$7.95	\$7.14	\$6.78
A10162-1023	9" x 12"	18.19	16.47	15.66
A10162-1005	11" x 14"	31.28	28.15	26.75

Yupo® Heavyweight Pads

This non-absorbent, heavyweight "paper" is made from 100% polypropylene. Waterproof and acid-free, it's incredibly strong with a very smooth surface. Ideal for aqueous techniques, offset printing, silkscreen, debossing, drawing, acrylic painting, and more. Resists buckling and warping. 10-sheet pads. 144 lb (390 gsm).

NUMBER	SIZE	EACH	12/EA
A09613-1000	5" x 7"	\$10.85	\$9.76
A09613-1023	9" x 12"	28.68	25.79
A09613-1005	11" x 14"	40.99	36.86

Strathmore® 400 Series Oil Painting Paper

A portable alternative to canvas and boards, this paper has a textured surface that mimics canvas and helps blend and hold paint layers in place.

No gesso required!

For finished artworks or for honing oil painting techniques with oil paints and oil pastels. 215 lb (350 gsm).

10-Sheet Pads

NUMBER	SIZE	EACH	12/EA
A09814-1023	9" x 12"	\$8.71	\$7.84
A09814-1004	12" x 12"	13.55	12.19
A09814-1009	18" x 24"	30.49	27.44

Sheet

NUMBER	SIZE	EACH	12/EA
A09814-1019	18" x 24"	\$4.57	\$4.11

Bienfang® Canvasette Paper Canvas Pads

This heavy paper with a canvas surface texture is excellent for practice. 10-sheet pads. 170 lb (281 gsm).

NUMBER	SIZE	EACH	6/EA
A08911-1003	9" x 12"	\$10.36	\$9.32
A08911-1006	12" x 16"	17.24	15.52
A08911-1008	16" x 20"	28.24	25.42
A08911-0009	18" x 24"	38.51	34.66

Strathmore® 300 Series Canvas Paper Pads

This heavyweight paper with a coated, textured, canvas-like surface is ideal for practicing techniques with oils, caseins, acrylics, alkyds, or egg tempera. 10-sheets pads. 115 lb (187 gsm).

White

NUMBER	SIZE	EACH	12/EA
A09803-1023	9" x 12"	\$9.12	\$8.21
A09803-1006	12" x 16"	14.49	13.04
A09803-1008	16" x 20"	23.75	21.37

Black

NUMBER	SIZE	EACH	12/EA
A09803-2023	9" x 12"	\$9.12	\$8.21
A09803-2026	12" x 16"	14.49	13.04
A09803-2028	16" x 20"	23.75	21.37

**Canson® Artist Series Canva-Paper™**

These economical pads hold 10 sheets of paper with a texture that resembles linen. Primed for oil and acrylic paints, the sheets are treated with a high-performance barrier to absorb oil, bonding agents, and water evenly, providing superb resistance by the surface paint layer. 136 lb (290 gsm).

Sheets

NUMBER	SIZE	EACH	12/EA
A08912-1003	9" x 12"	\$8.90	\$7.99
A08912-1006	12" x 16"	15.19	13.67
A08912-1008	16" x 20"	25.07	22.56

Rolls

NUMBER	SIZE	EACH	12/EA
A08912-1365	36" x 5 yd	\$43.27	\$38.94
A08912-1485	48" x 5 yd	52.23	46.99

**Canson® Plein Air Canva Artboards**

A combination of convenience and portability make these artboards ideal for plein air or studio use.

High-quality Canson papers in popular sizes are laminated to rigid, acid-free artboards to eliminate buckling, warping, and bleeding, then bound in convenient, portable pads. Use with oils and acrylics. 10-board pads are glued on one side, with a convenient fold-over cover.

NUMBER	SIZE	EACH	12/EA
A09812-1012	8" x 10"	\$16.29	\$14.66
A09812-1023	9" x 12"	19.27	17.34
A09812-1006	12" x 16"	31.86	28.67

**Brea Reese™ Waterproof Paper**

This smooth, non-porous, synthetic surface is ideal for alcohol ink techniques. Great for splattering, layering, blowing, daubing, and more, the durable, medium-weight polypropylene paper is quick-drying and buckle-resistant. Simply apply alcohol inks and blending solution directly to the surface — or distribute inks using a paintbrush, ink dauber, mister, foam roller, or straw.

NUMBER	DESCRIPTION	SIZE	EACH	12/EA
A09647-1023	9" x 12", 10-Sheet Pack		\$11.89	\$10.70
A09647-1012	12" x 47", Roll		9.91	8.92

Arches® Oil Paper

This high-tech paper features an oil barrier that absorbs water, solvents, and binders evenly while allowing paint and pigment to remain on the surface. Its exceptionally tough surface withstands heavy brushing, wet paint removal with turpentine, and palette knife use. Less stiff and brittle than gessoed papers, it resists chipping or cracking. It's also easy to cut, roll, store, and transport. 140 lb (300 gsm).

Sheets

NUMBER	SIZE	EACH	10/EA
A11753-1008	16" x 20"	\$5.27	\$4.74
A11753-1002	22" x 30"	11.17	10.05

12-Sheet Pads

NUMBER	SIZE	EACH	10/EA
A09811-1023	9" x 12"	\$17.44	\$15.70
A09811-1006	12" x 16"	33.81	30.43

51" x 10 yd Roll

NUMBER	EACH	10/EA
A11753-1010	\$292.51	\$263.26

Hahnemühle® Oil and Acrylic Paper Pads

For artists with good taste, nothing is better for presenting oil and acrylic paints than this paper. A canvas-like structure prevents colors from being completely absorbed, so there's no bleedthrough. A glossy linen finish helps colors retain their high luminosity without a halo effect. Colors can be mixed on the paper and oil patches won't appear. 110 lb (230 gsm). 10-sheet pads.

NUMBER	SIZE	EACH	6/EA
A09810-1007	7" x 9-1/2"	\$11.98	\$10.78
A09810-1095	9-1/2" x 12-1/2"	18.25	16.42
A09810-1012	12" x 16"	29.24	26.32
A09810-1014	14" x 19"	42.76	38.48

Royal & Langnickel® Essentials™ Oil Artist Pad

Achieve professional results with this economical alternative to canvas pads, stretched canvas, and higher-priced oil color pads. Royal & Langnickel Oil Artist Pads offer artist-quality paper with a canvas-like texture and stable structure that allows just the right amount of absorption and adhesion for oil paints and oil pastels, without bleedthrough or halo effect. Pads hold multiple sheets of 130 lb (220 gsm) paper.

NUMBER	DESCRIPTION	SIZE	EACH	12/EA
A08949-1015	15 Sheets	5" x 7"	\$1.78	\$1.60
A08949-1023	18 Sheets	9" x 12"	5.35	4.82

When ordering sheets of paper or board larger than 18" x 24", a handling fee may apply. See page 648.

Strathmore® 400 Series Acrylic Pads

This heavyweight, versatile, acid-free paper was made with the acrylic artist in mind. Cream-colored linen finish. 246 lb (400 gsm). 10-sheet pads.

NUMBER	SIZE	EACH	12/EA	24/EA
A09800-1006	6" x 6"	\$5.27	\$4.74	\$4.50
A09800-1023	12" x 9"	10.09	9.08	8.63
A09800-1024	12" x 12"	14.86	13.37	12.70
A09800-1025	12" x 18"	19.25	17.32	16.45
A09800-1029	18" x 24"	34.79	31.31	29.74

Grumbacher® Acrylic Pads

This 140 lb (300 gsm) white paper has an embossed texture and optimized sizing that makes it ideal for acrylic paints, markers, and inks. The dual-loop wirebound pads feature patent-pending "In & Out" pages that allow you to remove sheets from the pad for drawing, reworking, scanning, and more, then return them to the pad for transporting and safekeeping. 15-sheet pads.

NUMBER	SIZE	EACH	6/EA
A08951-1023	9" x 12"	\$13.22	\$11.90
A08951-1006	12" x 18"	21.74	19.57

Canson® Montval Acrylic Paper

Manufactured in France, this heavyweight textured paper is ideal for acrylic paint and wet techniques. When acrylics are used as a thick paste, characteristics similar to oil paint can be achieved on this paper. When diluted to a wash, the gelatin-sized paper features qualities of a cold press watercolor paper. 148 lb (400 gsm).

Sheet

NUMBER	SIZE	EACH	10/EA
A10077-1001	19-1/2" x 25-1/2"	\$3.82	\$3.44

Pads — 10 tapebound sheets.

NUMBER	SIZE	EACH	12/EA
A10152-1023	9" x 12"	\$13.64	\$12.28
A10152-1026	12" x 16"	26.71	24.04
A10152-1028	16" x 20"	38.29	34.46

Canson® XL® Oil & Acrylic Pads

No priming required! This French-made paper has a canvas-like texture and a bleedproof barrier that eliminates the need for priming before applying oils or acrylics. Each pad holds 24 sheets of acid-free, heavyweight, natural white paper, glued into a convenient foldover cover. 136 lb (290 gsm).

NUMBER	SIZE	EACH	4/EA
A09813-1023	9" x 12"	\$13.35	\$11.99
A09813-1005	11" x 14"	20.24	18.22

< Hahnemühle® College® Acrylic Paper Blocks

Priced for students, the robust 160 lb (350 gsm) natural white paper in these blocks ensures optimum results with both thick and thin layers of acrylic paint. Acid-free and age-resistant, it is ideal for finished work. 10-sheet blocks. Sized without the use of animal protein, the paper is certified vegan.

NUMBER	SIZE	EACH	4/EA
A08950-1001	9-1/2" x 12-1/2"	\$14.71	\$13.24
A08950-1002	11" x 15-1/2"	22.66	20.38
A08950-1003	14" x 18-3/4"	30.08	27.07



Strathmore® Printmaking Cards

Made from Strathmore's new 400 Series Printmaking Paper, this acid-free, heavyweight paper has a medium-texture surface that is soft, absorbent, and durable — ideal for creating custom greetings. 280 gsm.

NUMBER	DESCRIPTION	SIZE	EACH	12/EA
A10491-1056	Pack of 10	5" x 6-7/8"	\$7.99	\$7.19
A10491-5056	Pack of 50	5" x 6-7/8"	34.55	31.09

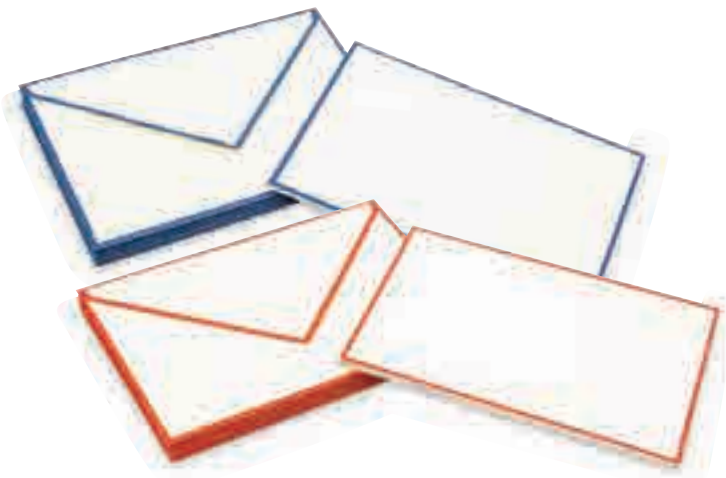

Orange Art™ Original Crown Mill™ Color Edge Cards

Orange Art Original Crown Mill Color Edge Cards are premium, Belgian-made stationary sets ideal for announcements, invitations, greeting cards, and more. Cards feature a smooth, flat finish and printed edges that contrast with the stationary's main color. Each set contains 10 cards with matching envelopes.

NUMBER	COLOR	EACH	5EA
A09506-5044	Cream/Navy	\$14.94	\$13.45
A09506-3014	Cream/Red	14.94	13.45



Canson® Blank Greeting Cards

These premium-weight, 5" x 7" cards and matching 5-1/4" x 7-1/4" envelopes provide the perfect foundation for pencils, pen-and-ink, stamping, markers, collage, debossing, and embellishments. All feature 140 lb (300 gsm) Montval cold press paper for use with all wet media. All come with matching envelopes (except for postcards).

NUMBER	DESCRIPTION	EACH	12/EA
A11912-1006	6 Cards w/Env	\$6.68	\$5.99
A11912-1030	30 Cards w/Env	24.12	21.71
A11912-1015	15 Postcards	6.68	5.99

Paper Accents Super Value Cards and Envelopes

Archival-quality cards in affordable packs! These acid-free, lignin-free, buffered cards made from heavyweight cardstock are great for use with pens, markers, paints, stamps, and stickers. The perfect choice for all writing, letterpress printing, and engraving applications. Packs include 50 cards and 50 envelopes.

NUMBER	COLOR	SIZE	EACH	6/EA
A09501-1105	Cream	4-1/4" x 5-1/2"	\$6.16	\$5.54
A09501-1107	Cream	5" x 7"	8.59	7.73
A09501-1025	White	4-1/4" x 5-1/2"	4.95	4.45
A09501-1027	White	5" x 7"	7.38	6.64

Fabrizio® Medioevalis Stationery

Crafted in Italy by the Fabrizio mill, this soft white deckle-edge stationery adds a distinctive flair to letters, invitations, and announcements. The mouldmade paper is the perfect setting for pen, pencil, charcoal, pastel, light washes, stamping, and inkjet printing. The folded cards also make excellent pages for handmade books. The cards are 260 gsm and the envelopes are 120 gsm.

Box of 100

NUMBER	DESCRIPTION	SIZE	EACH	5/EA
A10073-1040	Invitation Envelopes	6-1/2" x 8-1/2"	\$129.46	\$116.51
A10073-1070	Invitation Single Cards	6" x 8"	63.25	56.92
A10073-1090	Invitation Folded Cards	6" x 8"	96.56	86.90
A10032-1070	Regular Envelopes	4-1/2" x 7"	79.95	71.96
A10032-1040	Regular Single Cards	4-1/2" x 6-3/4"	42.50	38.25
A10032-1050	Landscape Folded Cards	4-1/2" x 6-3/4"	65.50	58.95
A10032-1060	Portrait Folded Cards	6-3/4" x 4-1/2"	65.50	58.95
A10073-1050	Reply Envelopes	3-1/2" x 5-1/2"	60.99	54.89
A10073-1080	Reply Single Cards	3-1/2" x 5-1/4"	35.27	31.74
A10073-1100	Reply Folded Cards	3-3/8" x 5-1/4"	47.80	42.99
A10073-1010	Enclosure Envelopes	2-3/4" x 4"	58.29	52.46
A10073-1020	Enclosure Single Cards	2-1/2" x 3-3/4"	33.06	32.75
A10073-1140	Square Format Folded Cards	4-3/4" x 4-3/4"	76.64	68.98
A10073-1047	Square Format Single Cards	4-3/4" x 4-3/4"	52.97	47.67
A10073-2055	Square Format Envelopes	5" x 5"	57.23	51.51

Portrait Folded Card



Landscape Folded Card

Cards & Envelopes

Box of 20 Cards w/Envelopes

NUMBER	DESCRIPTION	SIZE	EACH	5/EA
A10073-2030	Reply, Single Cards	3-2/5" x 5-1/4"	\$21.60	\$19.44
A10073-2034	Reply, Folded Cards	3-2/5" x 5-1/4"	23.31	20.98
A10073-2040	Regular, Single Cards	4-1/2" x 6-3/4"	26.56	23.90
A10073-2045	Regular, Folded Cards	4-1/2" x 6-3/4"	28.77	25.89

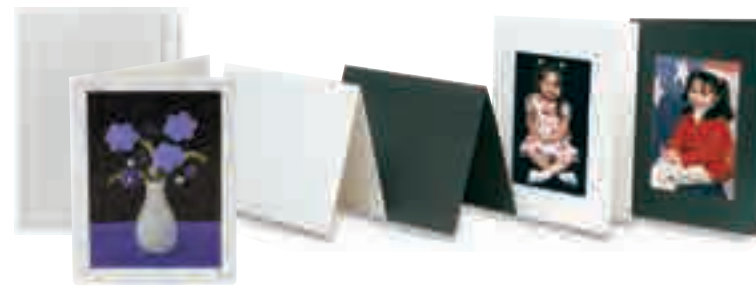

Strathmore® Photo Mount Cards and Envelopes

Mount your photos, artwork, or pictures to the front of these beautifully embossed cards. Each pack includes double-stick tabs for adhering up to a 4" x 6" picture. Matching envelopes are 5-1/4" x 7-1/4". Cards are 80 lb cover (216 gsm) weight and envelopes are 80 lb text (118 gsm) weight.

NUMBER	DESCRIPTION	EACH	6/EA	12/EA
A10401-1020	Classic Emboss, White, 10-pack	\$7.88	\$7.09	\$6.74
A12940-2110	Decorative Emboss, Black, 10-pack	9.43	8.49	8.07
A10401-1001	Decorative Emboss, White, 10-pack	7.88	7.09	6.74
A12940-1050	Decorative Emboss, White, 50-pack	29.05	26.14	23.53

Strathmore® Photo Frame Cards and Envelopes

These tri-fold cards feature a cutout window that accommodates either a 3-1/2" x 5" or a 4" x 6" photo (3-1/4" x 4-3/4" opening). Simply insert your photo or artwork at the folded edge of the card and personalize the frame. Double-stick adhesive tabs secure the picture. Matching envelopes are 5-1/4" x 7-1/4". Cards are 80 lb cover (216 gsm) weight and envelopes are 80 lb text (118 gsm) weight.

NUMBER	DESCRIPTION	EACH	6/EA	12/EA
A12940-1000	White, 10-pack	\$8.62	\$7.76	\$7.37
A12940-2010	Black, 10-pack	9.93	8.94	8.49
A12940-1051	White, 40-pack	26.30	23.67	22.49

Strathmore® Watercolor Cards and Postcards

Made from cold press, acid-free watercolor paper, these 140 lb (300 gsm) cards were created specifically to accept any wet media including watercolors, acrylics, gouache, and ink washes. Regular-size cards (in packs of 10, 50, and 100) measure 5" x 6-7/8". Slim cards measure 3-7/8" x 9". Announcement cards measure 3-1/2" x 4-7/8". All include matching 70 lb (104 gsm) envelopes. Postcard pad measures 4" x 6".

Cards

NUMBER	DESCRIPTION	EACH	6/EA	12/EA
A12940-1006	Announcement, 10-Pack	\$6.81	\$6.13	\$5.82
A12940-0010	Full, 10-Pack	7.81	7.03	6.68
A12940-1004	Slim, 10-Pack	7.81	7.03	6.68
A12940-1005	Full, 50-Pack	26.67	23.99	22.79
A12940-1612	Full, 100-Pack	44.96	40.46	38.44

Postcards

NUMBER	DESCRIPTION	EACH	6/EA	12/EA
A12940-1011	15 Cards	\$5.98	\$5.38	\$5.11



Strathmore® Colored Greeting Cards and Envelopes

Create unique greeting cards on heavier-weight paper. Ideal for holiday cards, invitations, and general correspondence. Boxes of 10 cards (5" x 6-7/8") with matching envelopes.

NUMBER	COLOR	EACH	12/EA
A12789-8230	Toned Tan	\$7.78	\$6.99
A12789-2520	Toned Gray	7.78	6.99
A09500-1001	Coal Black	7.78	6.99



Strathmore® Blank Greeting Cards and Envelopes

Just waiting for your personal touch.

This fine-quality paper is heavy enough for watercolor, and great for pen-and-ink, block printing, pastels, and pencil drawings. Available in Greeting Card size and Announcement Card size, perfect for formal announcements, invitations, or thank you cards. Pair with the Greeting Card size for RSVPs. All have a cold press surface, except for the Stamping White Cards and Envelopes. Cards are 80 lb cover (216 gsm) weight and envelopes are 80 lb text (118 gsm) weight.

Box of 10 Announcement Cards — Size 4-7/8" x 3-1/2" with matching envelopes.

NUMBER	DESCRIPTION	EACH	6/EA	12/EA
A12940-1110	Fluorescent White/White Deckle	\$6.81	\$6.13	\$5.82
A12940-1040	Ivory/Ivory Deckle	6.81	6.13	5.82
A12940-1001	Palm Beach White (No Deckle)	6.81	6.13	5.82
A12940-1002	Stamping (No Deckle)	6.81	6.13	5.82
A12940-1021	White/Blue Deckle	6.81	6.13	5.82

Box of 10 Greeting Cards — Size 5" x 6-7/8" with matching envelopes.

NUMBER	DESCRIPTION	EACH	6/EA	12/EA
A12940-1101	Fluorescent White/White Deckle	\$7.81	\$7.03	\$6.68
A12940-1041	Ivory/Ivory Deckle	7.81	7.03	6.68
A12940-1316	Palm Beach White (No Deckle)	7.81	7.03	6.68
A12940-1010	Stamping Card (No Deckle)	7.81	7.03	6.68

Box of 20 Greeting Cards — Size 5" x 6-7/8" with matching envelopes.

NUMBER	DESCRIPTION	EACH	6/EA	12/EA
A12940-1201	Fluorescent White/White Deckle	\$12.57	\$11.31	\$10.74
A12940-1042	Ivory/Ivory Deckle	12.57	11.31	10.74
A12940-1391	Palm Beach White (No Deckle)	12.57	11.31	10.74

Box of 50 Greeting Cards — Size 5" x 6-7/8" with matching envelopes.

NUMBER	DESCRIPTION	EACH	6/EA	12/EA
A12940-1430	Fluorescent White/White Deckle	\$25.04	\$22.54	\$21.41
A12940-1043	Ivory w/Deckle	25.04	22.54	21.41
A12940-1400	Palm Beach White (No Deckle)	25.04	22.54	21.41

Box of 100 Greeting Cards — Size 5" x 6-7/8" with matching envelopes.

NUMBER	DESCRIPTION	EACH	6/EA	12/EA
A12940-1012	Fluorescent White/White Deckle	\$38.53	\$34.68	\$32.95
A12940-1044	Ivory w/Deckle	38.53	34.68	32.95

Box of 10 Mixed Media Cards — Strathmore's 400 Series mixed media paper. 140 lb (300 gsm).

NUMBER	DESCRIPTION	EACH	6/EA	12/EA
A11988-1020	Announcement, 3-1/2" x 4-7/8"	\$6.26	\$5.63	\$5.35
A11988-1030	Full, 5" x 6-7/8"	7.52	6.77	6.43
A11988-1010	Slim, 3-7/8" x 9"	7.52	6.77	6.43





Canson® Mi-Teintes Touch Sanded Paper

Destined to become the artist's new favorite. Ideal for pastel, crayon, charcoal, colored pencil, silverpoint, stamping, and stenciling, the sanded surface also works well with wet media.

NUMBER	COLOR	EACH	10/EA	NUMBER	COLOR	EACH	10/EA
A10731-2002	Black	\$11.59	\$10.43	A10731-8082	Sepia	\$11.59	\$10.43
A10731-2532	Dark Grey	11.59	10.43	A10731-2592	Sky Grey	11.59	10.43
A10731-2172	Flannel Grey	11.59	10.43	A10731-2262	Steel Grey	11.59	10.43
A10731-5012	Light Blue	11.59	10.43	A10731-5662	Twilight	11.59	10.43

Shizen Pastel Paper

All Shizen papers are handmade in India from 100% recycled materials using a pollution-free process. This acid-free, 200 gsm pastel paper is made from 100% cotton rag, features four deckle edges, and comes in a variety of colors.

8-1/2" x 11" — 5-pack.

NUMBER	COLOR	EACH	25/EA
A10732-7910	Army Green	\$4.19	\$3.78
A10732-2020	Black	4.19	3.78
A10732-5010	Blue	4.19	3.78
A10732-5910	Blue Purple	4.19	3.78
A10732-8360	Cocoa	4.19	3.78
A10732-7030	Dark Green	4.19	3.78
A10732-2500	Gray	4.19	3.78
A10732-1040	Ivory	4.19	3.78
A10732-8230	Tan	4.19	3.78
A10732-1020	White	4.19	3.78

19" x 25" Sheet

NUMBER	COLOR	EACH	25/EA
A10732-7912	Army Green	\$3.14	\$2.82
A10732-2022	Black	3.14	2.82
A10732-5012	Blue	3.14	2.82
A10732-5912	Blue Purple	3.14	2.82
A10732-8362	Cocoa	3.14	2.82
A10732-7032	Dark Green	3.14	2.82
A10732-2502	Gray	3.14	2.82
A10732-1042	Ivory	3.14	2.82
A10732-8232	Tan	3.14	2.82
A10732-1022	White	3.14	2.82

8-1/2" x 11" — 25-pack.

NUMBER	COLOR	EACH	25/EA
A10732-0259	Multi-Color	\$17.99	\$16.19

Art Spectrum® Colourfix™ Coated Pastel Paper

This very permanent, lightfast product withstands all manner of artistic experimentation (and even punishment). The papers are used successfully in practically all media — pastels, charcoal, pencil, oils, acrylic, gouache, inks, silverpoint, and even watercolor. The unique, fine tooth surface is produced by screen printing Art Spectrum Colourfix Primer onto hot press watercolor paper. 140 lb (300 gsm).

19-1/2" x 27-1/2" Sheet

NUMBER	COLOR	EACH	25/EA
A10716-2500	Aubergine	\$12.86	\$10.91
A10716-2530	Australian Grey	12.86	10.91
A10716-5000	Blue Haze	12.86	10.91
A10716-3140	Burgundy	12.86	10.91
A10716-8050	Burnt Umber	12.86	10.91
A10716-2140	Deep Black	12.86	10.91
A10716-5250	Deep Ultra	12.86	10.91
A10716-2800	Elephant	12.86	10.91
A10716-2520	Fresh Grey	12.86	10.91
A10716-7150	Leaf Green Dark	12.86	10.91
A10716-1370	Natural	12.86	10.91
A10716-7070	Olive Green	12.86	10.91
A10716-8060	Raw Sienna	12.86	10.91
A10716-8140	Rich Beige	12.86	10.91
A10716-2510	Rose Grey	12.86	10.91
A10716-8530	Sand	12.86	10.91
A10716-8520	Soft Umber	12.86	10.91
A10716-5910	Storm Blue	12.86	10.91
A10716-8170	Terra Cotta	12.86	10.91
A10716-1010	White	12.86	10.91

9" x 12" Sheet

NUMBER	COLOR	EACH	10/EA
A10716-2503	Aubergine	\$3.62	\$3.27
A10716-2553	Australian Grey	3.62	3.27
A10716-5003	Blue Haze	3.62	3.27
A10716-3143	Burgundy	3.62	3.27
A10716-8053	Burnt Umber	3.62	3.27
A10716-2143	Deep Black	3.62	3.27
A10716-5253	Deep Ultra	3.62	3.27
A10716-2803	Elephant	3.62	3.27
A10716-2523	Fresh Grey	3.62	3.27
A10716-7153	Leaf Green Dark	3.62	3.27
A10716-1353	Natural	3.62	3.27
A10716-7073	Olive Green	3.62	3.27
A10716-8063	Raw Sienna	3.62	3.27
A10716-2513	Rose Grey	3.62	3.27
A10716-8143	Rich Beige	3.62	3.27
A10716-8533	Sand	3.62	3.27
A10716-8523	Soft Umber	3.62	3.27
A10716-5913	Storm Blue	3.62	3.27
A10716-8173	Terra Cotta	3.62	3.27
A10716-1013	White	3.62	3.27

Rainbow Pack — All 20 colors in 9" x 12".

NUMBER	EACH
A10716-1033	\$66.12



Warm Color Assortment — Includes the following 10 warm tones in a 9" x 12" sheet pack: Aubergine, Australian Grey, Burgundy, Burnt Umber, Olive Green, Raw Sienna, Rich Beige, Sand, Soft Umber, and Terra Cotta.

NUMBER	EACH
A10716-1023	\$35.86



Cool Color Assortment — Includes the following 10 cool tones in a 9" x 12" sheet pack: Blue Haze, Deep Black, Deep Ultra, Elephant, Fresh Grey, Leaf Green Dark, Natural, Rose Grey, Storm Blue, and White.

NUMBER	EACH
A10716-1003	\$35.86



Strathmore® 400 Series Pastel Pads

The textured finish and subtle colors make this paper an ideal background for oil pastel. Also suitable for hard or soft pastels. Pads contain 24 sheets, four each of six different colors. 80 lb (118 gsm), acid-free paper.

NUMBER	SIZE	EACH	12/EA
A10800-1023	9" x 12"	\$7.20	\$6.48
A10800-1005	11" x 14"	8.99	8.09
A10800-1009	18" x 24"	18.47	16.62

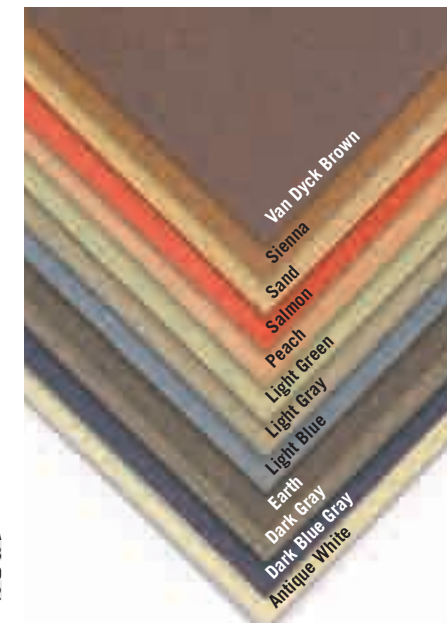

Strathmore® 300 Series Wire Bound Charcoal Pads and Rolls

A natural white paper with a traditional laid finish that is ideal for charcoal and pastel. The surface is strong enough to hold up to oil pastel and crayon. 64 lb (95 gsm). 18" x 24" pad has 24 sheets; other pads have 32 sheets.

NUMBER	SIZE	EACH	12/EA
A10207-0000	9" x 12"	\$8.20	\$7.38
A10207-0010	11" x 17"	12.50	11.25
A10207-0009	18" x 24"	22.62	20.36
A10207-1036	36" x 10 yd, Roll	15.53	13.98



Strathmore® 400 Series Gray Scale Pads

Ideal for value studies, three sheets of white, black, and three shades of gray in a perfect texture for charcoal or pastel. 80 lb (216 gsm), acid-free paper in a 15-sheet, tapebound pad.

NUMBER	SIZE	EACH	12/EA
A10810-1003	9" x 12"	\$7.67	\$6.90
A10810-1006	12" x 18"	13.99	12.59
A10810-1009	18" x 24"	22.92	20.63

Sennelier® La Carte Pastel Card

Finely ground, pH-neutral vegetable flakes are hand-applied to 200 lb (360 gsm), pH-neutral board stock, creating a paper that is slightly abrasive, yet has a perfectly smooth, uniform tooth. Pigment adhesion is so greatly enhanced that less fixative is required. Offers an excellent surface for any dry media. 19" x 25" sheets. Use of wet media not recommended.

Colors can be assorted for quantity pricing.

NUMBER	COLOR	EACH	10/EA	20/EA
A10708-1361	Antique White	\$17.46	\$15.72	\$14.93
A10708-2101	Dark Blue Gray	17.46	15.72	14.93
A10708-2531	Dark Gray	17.46	15.72	14.93
A10708-7211	Earth	17.46	15.72	14.93
A10708-5011	Light Blue	17.46	15.72	14.93
A10708-2281	Light Gray	17.46	15.72	14.93
A10708-7011	Light Green	17.46	15.72	14.93
A10708-3351	Peach	17.46	15.72	14.93
A10708-3691	Salmon	17.46	15.72	14.93
A10708-8511	Sand	17.46	15.72	14.93
A10708-8121	Sienna	17.46	15.72	14.93
A10708-6151	Van Dyck Brown	17.46	15.72	14.93



Sennelier® La Carte Pastel Card Pads

Twelve sheets in six popular colors of Sennelier La Carte pastel papers are tapebound in a pad, perfect for traveling or working on location. Sheets detach cleanly and easily, so finished art remains intact. Recommended for all dry media. 200 lb (360 gsm).

NUMBER	SIZE	EACH	6/EA
A10818-1023	9" x 12"	\$52.97	\$47.88
A10818-1006	12" x 16"	82.11	73.90

Pastelmat™

A unique, velvety surface with excellent "grabbing" power, Pastelmat card is also an ideal surface for pencil and charcoal. Its fine, well-fixed particles assure a smooth surface and comfort of use, while cork grain in the adhesive ensures longevity. Ideal for positioning multiple layers, and for flat tints, precise details, or delicate and transparent veils. 170 lb (360 gsm).

19-1/2" x 27-1/2" Sheets

NUMBER	DESCRIPTION	EACH	5/EA
A10820-8320	Anthracite	\$21.28	\$19.15
A10820-8010	Brown	21.28	19.15
A10820-4080	Buttercup	21.28	19.15
A10820-2530	Dark Gray	21.28	19.15
A10820-2510	Light Gray	21.28	19.15
A10820-4370	Maize	21.28	19.15
A10820-8120	Sienna	21.28	19.15
A10820-1020	White	21.28	19.15

12-Sheet Pads

NUMBER	DESCRIPTION	EACH	5/EA
A10820-1021	7" x 9" A Colors	\$37.71	\$33.94
A10820-1023	9" x 12" A Colors	55.42	49.88
A10820-1006	12" x 16" A Colors	85.79	77.20
A10820-2021	7" x 9" B Colors	37.71	33.94
A10820-2023	9" x 12" B Colors	55.42	49.88
A10820-2006	12" x 16" B Colors	85.79	77.20
A10820-1121	7" x 9" White Only	37.71	33.94
A10820-1123	9" x 12" White Only	55.42	49.88
A10820-1106	12" x 16" White Only	85.79	77.20



Hand Book Paper Co.™ Pastel Premier™ Sanded Pastel Paper

An ideal surface for pastel painting, Pastel Premier is double-primed and coated with aluminum oxide, then seal-coated to make the surface able to withstand almost any amount of scrubbing and reworking. It works with a wide range of wet media as an under-painting and can accept as many as 25 pastel layers. Made in the USA from 100% cotton. Archival quality. 140 lb (310 gsm).

Fine 400 Grit — White

NUMBER	DESCRIPTION	SIZE	EACH	6/EA
A10738-1024	1 Sheet	26" x 40"	\$33.54	\$30.19
A10738-1021	1 Sheet	20" x 26"	17.30	15.57
A10738-1026	6 Sheets	12" x 16"	41.81	37.63
A10738-1023	8 Sheets	9" x 12"	35.54	31.99
A10738-1020	Roll	53" x 5 yd	298.06	268.25

Medium Fine 320 Grit — Italian Clay

NUMBER	DESCRIPTION	SIZE	EACH	6/EA
A10738-2064	1 Sheet	26" x 40"	\$33.54	\$30.19
A10738-2061	1 Sheet	20" x 26"	17.30	15.57
A10738-2066	6 Sheets	12" x 16"	41.81	37.63
A10738-2063	8 Sheets	9" x 12"	35.54	31.99
A10738-2060	Roll	53" x 5 yd	298.06	268.25



Strathmore® 300 Series Glue Bound Charcoal Pads

A natural white paper with a traditional laid finish that's ideal for charcoal and pastel. The surface is strong enough to stand up to oil pastels and crayons. 64 lb (95 gsm). 18" x 24" pad contains 24 sheets; other pads contain 32 sheets.

Tape Bound

NUMBER	SIZE	EACH	12/EA
A10812-1373	9" x 12"	\$8.30	\$7.47
A10812-1377	11" x 17"	11.70	10.53
A10812-1109	18" x 24"	21.69	19.52

Fabrian® Tiziano Pastel and Charcoal Paper

You'll see and feel the difference as your pastels bite into the extraordinarily toothy surface of this pastel, charcoal, and pencil paper. Available in 40 colors, it features a grain that runs parallel to the long side and is acid-free. 40% cotton. 160 gsm. **Colors can be assorted for quantity pricing.**

20" x 26" Sheets			
NUMBER	COLOR	EACH	10/EA
A10700-5361	Aquamarine	\$2.73	\$2.46
A10700-4011	Banana	2.73	2.46
A10700-7011	Billiard Green	2.73	2.46
A10700-2001	Black	2.73	2.46
A10700-5011	Blue Gray	2.73	2.46
A10700-5801	Blue Night	2.73	2.46
A10700-3181	Burgundy	2.73	2.46
A10700-8021	Coffee	2.73	2.46
A10700-2131	Charcoal	2.73	2.46
A10700-1101	Cream	2.73	2.46
A10700-7051	Emerald Green	2.73	2.46
A10700-2161	Felt Gray	2.73	2.46
A10700-2281	Felt Light Gray	2.73	2.46
A10700-3551	Fire Red	2.73	2.46
A10700-9011	Gold	2.73	2.46
A10700-4021	Honey	2.73	2.46
A10700-5041	Indigo	2.73	2.46
A10700-6411	Iris	2.73	2.46
A10700-1041	Ivory	2.73	2.46
A10700-3021	Lava Red	2.73	2.46
A10700-4111	Lemon	2.73	2.46
A10700-5021	Light Blue Gray	2.73	2.46
A10700-7021	Light Green	2.73	2.46
A10700-6131	Lilac	2.73	2.46
A10700-7521	Moss Green	2.73	2.46
A10700-5031	Navy Blue	2.73	2.46
A10700-4511	Orange	2.73	2.46
A10700-5001	Pale Felt Blue	2.73	2.46
A10700-7031	Pistachio	2.73	2.46
A10700-2401	Pearl Gray	2.73	2.46
A10700-8121	Raw Sienna	2.73	2.46
A10700-3041	Red Violet	2.73	2.46
A10700-3171	Rose	2.73	2.46
A10700-2471	Rose Gray	2.73	2.46
A10700-7401	Sage	2.73	2.46
A10700-8011	Sahara	2.73	2.46
A10700-5051	Seabright	2.73	2.46
A10700-2661	Steel Gray	2.73	2.46
A10700-8231	Tan	2.73	2.46
A10700-1021	White	2.73	2.46

Pochette — 9-1/2" x 12-1/2" sheets, 12 colors.			
NUMBER	EACH	10/EA	20/EA
A10700-1009	\$7.35	\$6.61	\$6.28

UArt® Sanded Pastel Paper

A premium, neutral-colored, sanded pastel paper offering high quality, consistency, and durability. The 240 grade has the largest tooth, the 280 grade is for a heavier hand and texture, the 320 grade is for extra layering, the 400 and 500 grade have a moderate "bite," the 600 grade is great for details, and the 800 grade is super fine. All accept many layers of hard or soft pastels and also work well with other mediums. The low-profile surface allows for easy erasing. pH-neutral and acid-neutral. **Colors can be assorted for quantity pricing.**

Sheets					
NUMBER	SIZE	GRADE	EACH	10/EA	20/EA
A10725-2403	9" x 12"	240	\$3.06	\$2.75	\$2.61
A10725-4023	9" x 12"	400	3.06	2.75	2.61
A10725-5023	9" x 12"	500	3.06	2.75	2.61
A10725-6023	9" x 12"	600	3.06	2.75	2.61
A10725-8023	9" x 12"	800	3.06	2.75	2.61
A10725-2406	12" x 18"	240	6.08	5.45	5.18
A10725-4006	12" x 18"	400	6.08	5.45	5.18
A10725-5006	12" x 18"	500	6.08	5.45	5.18
A10725-6006	12" x 18"	600	6.08	5.45	5.18
A10725-8006	12" x 18"	800	6.08	5.45	5.18
A10725-2409	18" x 24"	240	9.82	8.83	8.39
A10725-4009	18" x 24"	400	9.82	8.83	8.39
A10725-5009	18" x 24"	500	9.82	8.83	8.39
A10725-6009	18" x 24"	600	9.82	8.83	8.39
A10725-8009	18" x 24"	800	9.82	8.83	8.39
A10725-2407	21" x 27"	240	10.31	9.28	8.81
A10725-4027	21" x 27"	400	10.31	9.28	8.81
A10725-5027	21" x 27"	500	10.31	9.28	8.81
A10725-6027	21" x 27"	600	10.31	9.28	8.81
A10725-8027	21" x 27"	800	10.31	9.28	8.81
A10725-2405	24" x 36"	240	17.46	15.74	14.95
A10725-4015	24" x 36"	400	17.46	15.74	14.95
A10725-5015	24" x 36"	500	17.46	15.74	14.95
A10725-6015	24" x 36"	600	17.46	15.74	14.95
A10725-8015	24" x 36"	800	17.46	15.74	14.95
A10725-2400	27" x 40"	240	18.76	16.88	16.04
A10725-4040	27" x 40"	400	18.76	16.88	16.04
A10725-5040	27" x 40"	500	18.76	16.88	16.04
A10725-6040	27" x 40"	600	18.76	16.88	16.04
A10725-8040	27" x 40"	800	18.76	16.88	16.04

Premium Sanded Pastel Paper Boards — The strongest and most durable mounted boards available! UArt's Premium Sanded Pastel Paper is affixed to these sturdy boards with acid-free glue. Great for pastels and other media.					
NUMBER	SIZE	GRADE	EACH	6/EA	20/EA
A10745-2423	9" x 12"	240	\$15.66	\$14.10	
A10745-2823	9" x 12"	280	15.66	14.10	
A10745-3223	9" x 12"	320	15.66	14.10	
A10745-4023	9" x 12"	400	15.66	14.10	
A10745-5023	9" x 12"	500	15.66	14.10	
A10745-6023	9" x 12"	600	15.66	14.10	
A10745-8023	9" x 12"	800	15.66	14.10	
A10745-2418	12" x 16"	240	20.09	18.07	
A10745-2818	12" x 16"	280	20.09	18.07	
A10745-3218	12" x 16"	320	20.09	18.07	
A10745-4018	12" x 16"	400	20.09	18.07	
A10745-5018	12" x 16"	500	20.09	18.07	
A10745-6018	12" x 16"	600	20.09	18.07	
A10745-8018	12" x 16"	800	20.09	18.07	
A10745-2424	18" x 24"	240	35.03	31.49	

Rolls					
NUMBER	SIZE	GRADE	EACH	6/EA	20/EA
A10725-4056	56" x 10 yd	400	\$214.25	\$192.82	
A10725-5056	56" x 10 yd	500	214.25	192.82	
A10725-6056	56" x 10 yd	600	214.25	192.82	
A10725-8056	56" x 10 yd	800	214.25	192.82	



UArt® Sanded Pastel Paper Pads

UArt's premium sanded pastel paper combines quality, consistency, and durability. Ideal for a wide range of media, including pastels, colored pencils, and charcoal, the 400 grade has a moderate "bite," while the 600 grade is super fine. Each sheet is pH-neutral and acid-free, with a low-profile surface that erases easily. The 9" x 12" flip-pads hold 10 sheets, separated by acid-free sheets to protect work from smudging and flaking.

NUMBER	COLOR	GRADE	EACH	3/EA
A00509-1034	Black	400	\$30.72	\$27.65
A00509-1036	Black	600	30.72	27.65
A00509-1038	Black	800	30.72	27.65
A00509-8144	Sand	400	30.72	27.65
A00509-8146	Sand	600	30.72	27.65



UArt® Dark Premium Sanded Pastel Paper

This is the perfect surface for those artists looking for a dark sanded substrate. The color of the paper fluctuates depending on the grit — the higher the grade, the smaller the pigment. The 400 provides a rich, dark black color, and the 600 and 800 grit tend toward a charcoal color. **Colors can be assorted for quantity pricing.**

NUMBER	SIZE	GRADE	EACH	10/EA	20/EA
A10725-4003	9" x 12"	400	\$3.06	\$2.75	\$2.61
A10725-5003	9" x 12"	500	3.06	2.75	2.61
A10725-6003	9" x 12"	600	3.06	2.75	2.61
A10725-8003	9" x 12"	800	3.06	2.75	2.61
A10725-4018	12" x 18"	400	6.08	5.45	5.18
A10725-5018	12" x 18"	500	6.08	5.45	5.18
A10725-6018	12" x 18"	600	6.08	5.45	5.18
A10725-8018	12" x 18"	800	6.08	5.45	5.18
A10725-4024	18" x 24"	400	9.82	8.83	8.39
A10725-5024	18" x 24"	500	9.82	8.83	8.39
A10725-6024	18" x 24"	600	9.82	8.83	8.39
A10725-8024	18" x 24"	800	9.82	8.83	8.39
A10725-4021	21" x 27"	400	10.31	9.28	8.81
A10725-5021	21" x 27"	500	10.31	9.28	8.81
A10725-6021	21" x 27"	600	10.31	9.28	8.81
A10725-8021	21" x 27"	800	10.31	9.28	8.81
A10725-4036	24" x 36"	400	17.46	15.74	14.95
A10725-5036	24" x 36"	500	17.46	15.74	14.95
A10725-6036	24" x 36"	600	17.46	15.74	14.95
A10725-8036	24" x 36"	800	17.46	15.74	14.95
A10725-4004	27" x 40"	400	22.99	20.71	19.65
A10725-5004	27" x 40"	500	22.99	20.71	19.65
A10725-6004	27" x 40"	600	22.99	20.71	19.65
A10725-8004	27" x 40"	800	22.99	20.71	19.65

CANSON MI-TEINTES®



Canson® Mi-Teintes® Boards

Real Mi-Teintes sheets mounted to 60 pt sulphite white board. A great choice for matting and framing, these boards are a truly ideal substrate for pastel painting. All colors are acid-free and lignin-free. The same is true for the backing board. 16" x 20". **Colors can be assorted for quantity pricing.**

NUMBER	COLOR	EACH	5/EA	10/EA
A13011-2008	Black	\$4.82	\$4.34	\$4.12
A13011-3188	Burgundy	4.82	4.34	4.12
A13019-8068	Cream	4.82	4.34	4.12
A13011-2208	Dark Gray	4.82	4.34	4.12
A13019-2168	Felt Gray	4.82	4.34	4.12
A13019-2178	Flannel Gray	4.82	4.34	4.12
A13011-1048	Ivory	4.82	4.34	4.12
A13019-2358	Moonstone	4.82	4.34	4.12
A13011-1128	Pearl	4.82	4.34	4.12
A13019-2408	Pearl Gray	4.82	4.34	4.12
A13011-2218	Steel Gray	4.82	4.34	4.12
A13019-2718	Tobacco	4.82	4.34	4.12
A13011-1028	White	4.82	4.34	4.12

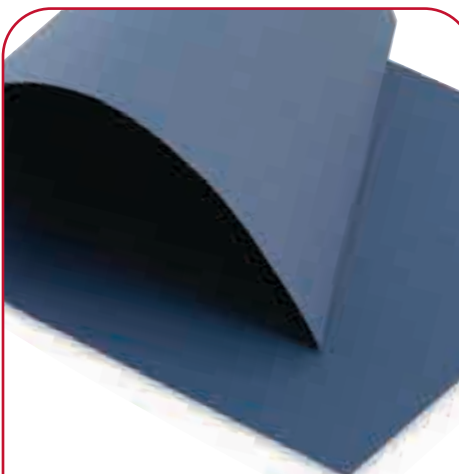

Canson® Ingres Papers

The same lightfast color range as Mi-Teintes, but in a lighter weight with a "laid" finish for chalk, pastel, pencil, or charcoal. This 65% rag, gelatin-sized, acid-free paper is colored in the pulp to ensure light-resistance. Great for drawing and printing. 19" x 25" sheets. 100 gsm. **Colors can be assorted for quantity pricing.**

NUMBER	COLOR	EACH	25/EA
A10711-1101	Cream	\$2.14	\$1.93
A10711-5031	Dark Blue	2.14	1.93
A10711-2351	Moonstone	2.14	1.93
A10711-5071	Sky Blue	2.14	1.93
A10711-2661	Steel Gray	2.14	1.93
A10711-2691	Stygian Black	2.14	1.93
A10711-1001	White	2.14	1.93



A-E Canson® Mi-Teintes® Assorted Color Packs

Five perfectly themed packs, each containing an assortment of 10 popular Mi-Teintes drawing papers in a variety of colors. 19" x 25" sheets. 98 lb (160 gsm).

NUMBER	DESCRIPTION	EACH	10/EA
A10722-1010	A Bright	\$30.51	\$27.46
A10722-1030	B Fine Art	30.51	27.46
A10722-1050	C Muted	30.51	27.46
A10722-1020	D Pastel	30.51	27.46
A10722-1040	E Portrait	30.51	27.46



F Canson® Mi-Teintes® Tapebound Pads

These tapebound pads are especially well-suited to pastels. Each 24-sheet pad contains four sheets each of six different colors. For colors, visit DickBlick.com.

NUMBER	SIZE	WEIGHT	EACH	6/EA	12/EA
A10710-1239	9" x 12"	98 lb (160 gsm)	\$10.26	\$9.23	\$8.11
A10710-1209	12" x 16"	98 lb (160 gsm)	14.32	12.89	12.25

Earth Colors

NUMBER	SIZE	WEIGHT	EACH	6/EA	12/EA
A10710-8513	9" x 12"	98 lb (160 gsm)	\$10.26	\$9.23	\$8.11
A10710-8516	12" x 16"	98 lb (160 gsm)	14.32	12.89	12.25

Gray Tones

NUMBER	SIZE	WEIGHT	EACH	6/EA	12/EA
A10710-2013	9" x 12"	98 lb (160 gsm)	\$10.26	\$9.23	\$8.11
A10710-2016	12" x 16"	98 lb (160 gsm)	14.32	12.89	12.25

G Canson® Mi-Teintes® Spiral Pad

This all-time favorite paper in a spiral pad has ultra-smooth glassine slipsheets between each page to protect drawings and prevent smudging. Pad contains 16, 12" x 9" sheets of 98 lb (160 gsm) white paper.

NUMBER	EACH	6/EA	12/EA
A10379-1003	\$17.10	\$15.39	\$

Strathmore® 500 Series Charcoal Papers

A 100% cotton fiber paper that has a traditional laid pattern for precise shading with charcoal and pastels. Its raised texture is also suitable for pen, pencil, or art crayon. Acid-free. 64 lb (95 gsm). **Colors can be assorted for quantity pricing.**

NUMBER	COLOR	EACH	25/EA	100/EA
A10703-2001	Black	\$1.71	\$1.54	\$1.46
A10703-5001	Blue Gray	1.71	1.54	1.46
A10703-1151	Bright White	1.71	1.54	1.46
A10703-1001	White	1.71	1.54	1.46



Assorted 24-Sheet Pads — Spiral-bound on short side.

NUMBER	SIZE	EACH	6/EA	12/EA
A10811-1023	9" x 12"	\$10.96	\$9.86	\$9.37
A10803-0069	12" x 18"	18.12	16.31	15.49
A10803-0099	18" x 24"	29.75	26.77	25.43

White 24-Sheet Pads — Spiral-bound on short side.

NUMBER	SIZE	EACH	6/EA	12/EA
A10803-1003	9" x 12"	\$7.39	\$6.65	\$6.32
A10803-1007	12" x 18"	12.47	11.22	10.66
A10803-1009	18" x 24"	20.96	18.86	17.92

Hahnemühle® Bugra Pastel Paper

This paper is mouldmade in Germany. Its duo-surface — "laid," toothy texture on one side, smooth on the reverse — offers artists a choice. Specifically made for pastels and charcoal, it also works well with pencil, graphite, and other drawing mediums. 65 lb (130 gsm), pH-neutral, and highly lightfast.

Large-size 33" x 41" sheets. **Colors can be assorted for quantity pricing.**

NUMBER	COLOR	EACH	25/EA	50/EA
A10702-2006	Black	\$9.29	\$8.37	\$7.53
A10702-5006	Blue	6.67	5.99	5.70
A10702-8856	Fawn Brown	6.67	5.99	5.70
A10702-2226	Gray	6.67	5.99	5.70
A10702-2296	Marble Gray	6.67	5.99	5.70
A10702-7516	Mint	6.67	5.99	5.70
A10702-8326	Mocha	6.67	5.99	5.70
A10702-5296	Sapphire Blue	6.67	5.99	5.70
A10702-1006	White	6.67	5.99	5.70



Art Spectrum® Colourfix Smooth Pastel Papers

Ideal for artists looking for a less toothy surface, this paper is less abrasive than Colourfix Coated Pastel Paper yet still holds multiple layers of pastels (but with minimum harm to fingertips when blending). The smooth yet toothy surface is ideal for pastels, pencil, or charcoal, as it will hold multiple overlays of color without the need to fix between layers. Use also with oils, acrylics, gouache, inks, silverpoint, even watercolors. Apply a final light spray of fixative if desired. Acid-free. 230 lb (340 gsm).

9" x 12" — Packages

NUMBER	DESCRIPTION	EACH
A10744-1203	Cool Pack, 10 sheets	\$35.86
A10744-1103	Warm Pack, 10 sheets	35.86
A10744-1003	Rainbow Pack, 20 sheets	73.87

Single Sheets

NUMBER	COLOR	SIZE	EACH	10/EA
A10744-1303	Clear	9" x 12"	\$4.15	\$3.74
A10744-2143	Deep Black	9" x 12"	4.15	3.74
A10744-8433	Soft Umber	9" x 12"	4.15	3.74
A10744-1023	White	9" x 12"	4.15	3.74
A10744-1308	Clear	20" x 28"	11.18	10.07
A10744-2148	Deep Black	20" x 28"	11.18	10.07
A10744-8438	Soft Umber	20" x 28"	11.18	10.07
A10744-1028	White	20" x 28"	11.18	10.07

Did you know we have hundreds of lesson plans designed to meet the National Standards for Visual Arts Education? See them all at DickBlick.com/lesson-plans.

NUMBER	EACH	6/EA
A10743-1023	\$7.40	\$6.66

Hahnemühle® Ingres Antique Paper

Mouldmade in Germany, this paper has an attractive toothy finish and even-laid formation. Excellent for drawing and printing. Watermarked, four deckle edges, pH-neutral, lightfast. 18-3/4" x 24-3/4" sheets. 27 lb (100 gsm). **Colors can be assorted for quantity pricing.**

NUMBER	COLOR	EACH	10/EA	50/EA
A10213-1259	Antique	\$2.11	\$1.90	\$1.80
A10213-2009	Black	2.11	1.90	1.80
A10213-7089	Blue-Green	2.11	1.90	1.80
A10213-8719	Camel	2.11	1.90	1.80
A10213-1239	Custard	2.11	1.90	1.80
A10213-7219	Earth	2.11	1.90	1.80
A10213-2589	Silver Gray	2.11	1.90	1.80
A10213-2649	Smoke	2.11	1.90	1.80
A10213-1009	White	2.11	1.90	1.80



Hahnemühle® Premium Velour Paper

Hahnemühle Velour is a soft and luxurious acid-free paper. You'll love the way pastels and charcoal look when stroked on this unique surface. Spray fixative should be used often, and finished art should be handled with care. Individual sheets measure approximately 19" x 27". 260 gsm. **Colors can be assorted for quantity pricing.**

NUMBER	COLOR	EACH	10/EA	25/EA
A10707-2001	Black	\$9.44	\$8.50	\$8.07
A10707-2531	Dark Gray	9.44	8.50	8.07
A10707-2281	Light Gray	9.44	8.50	8.07
A10707-2311	Middle Gray	9.44	8.50	8.07
A10707-8381	Ochre	9.44	8.50	8.07
A10707-8511	Sand	9.44	8.50	8.07
A10707-1001	White	9.44	8.50	8.07
A10707-4001	Yellow	9.44	8.50	8.07

10-Sheet Pad — Assorted pad contains colors listed above in a 9.4" x 12.6" size.

NUMBER	EACH	10/EA	20/EA
A10707-1039	\$35.06	\$31.55	\$29.97

Hahnemühle Velour Board — Same as Hahnemühle Velour Paper, reinforced by a sturdy backing board. Sheet size is approximately 19" x 27".

NUMBER	COLOR	EACH	10/EA	20/EA
A14923-2000	Black	\$20.29	\$18.26	\$17.35
A14923-2530	Dark Gray	20.29	18.26	17.35
A14923-7000	Green	20.29	18.26	17.35
A14923-2510	Light Gray	20.29	18.26	17.35
A14923-2520	Middle Gray	20.29	18.26	17.35
A14923-4040	Ochre	20.29	18.26	17.35
A14923-4500	Orange	20.29	18.26	17.35
A14923-4910	Sand	20.29	18.26	17.35
A14923-1000	White	20.29	18.26	17.35
A14923-4000	Yellow	20.29	18.26	17.35



Japanese papers

Japanese paper is like no other paper in the world. Often, it's handmade using centuries-old traditions, using the finest-quality fibers from plants found only in the Far East. Japanese paper is prized for lino and wood block printing, sumi painting, brush calligraphy, book binding, interleaving, fly leaf, end leaf, and many decorative and conservation applications.

Kinwashi

Machine-made of short, thick manila fibers. Paper has bark inclusions which provide texture on one side of the sheet while remaining smooth on the other side. Deckle edges, 25" x 37" sheets (30 gsm), sized.

NUMBER	EACH	10/EA
A10414-1005	\$7.13	\$6.42

Kitakata

Mitsumata fibers produce a soft, smooth surface with a natural gloss. The silky touch makes this paper a favorite. Sized, acid-free, four deckle edges. 16" x 20" sheets (30 gsm), sized.

NUMBER	EACH	10/EA
A10416-1008	\$5.08	\$4.57

Unryu

Literally meaning "Cloud Dragon Paper," Unryu is made by adding long, swirling fibers to a basic kozo pulp. White, translucent, unsized, acid-free. 24" x 39" sheets.

NUMBER	EACH	10/EA
A10404-1005	\$5.49	\$4.94

Sekishu

This is one of the oldest papers in the world and is still made today by hand. It is a strong, crisp, deep cream-colored paper made from kozo fibers. Sized, naturally acid-free, with deckle edges. 24" x 39" sheets (30 gsm).

NUMBER	EACH	10/EA
A10413-1005	\$11.83	\$10.65

Masa

Machine-made in Japan of sulphite pulp. Versatile and very reasonably priced. A strong paper with an even formation. Sized, 21" x 31" sheets (77 gsm).

NUMBER	EACH	25/EA
A10409-1003	\$2.46	\$2.21

Okawara

Handmade of kozo fibers and sulphite. Soft, supple, strong. Laid lines are almost invisible. Natural white, sized, acid-free, deckle edges. 12" x 16" sheets (55 gsm).

NUMBER	EACH	10/EA
A10411-1006	\$6.69	\$5.99

Mulberry

Handmade from the inner fiber of the mulberry plant to produce an exceptionally pure, translucent paper, used by paper and painting conservators in repair and lamination. Mulberry is very strong despite its light weight. Not sized, acid-free, four deckle edges. 24" x 33-1/2" sheets (45 gsm).

NUMBER	EACH	10/EA
A10410-1005	\$8.89	\$7.99

Hosho

A traditionally high-quality kozo paper, strong and absorbent, Hosho does not shrink or tear easily, making it a good paper for woodblock or lino printing. Sized, acid-free, four deckle edges. 19" x 24" sheets (85 gsm).

NUMBER	EACH	10/EA
A10415-1009	\$8.28	\$7.45

Hosho Student Grade

Similar to Hosho but slightly heavier and coarser. Sized, acid-free. Four deckle edges. 17" x 22" sheets (95 gsm).

NUMBER	EACH	10/EA
A10405-1008	\$6.22	\$5.60

Hahnemühle® Sumi-e Pad

"Sumi" means "black ink" and "e" means both "path" and "painting." This very absorbent 80 gsm paper was designed for this simple drawing style made of powerful (mostly chasing), rapidly executed lines.

20-Sheet Pads

NUMBER	SIZE	EACH	6/EA
A12487-1095	9" x 12"	\$25.23	\$22.71
A12487-1012	12" x 16"	39.08	35.98

Awagami Shiramine Select

Crafted at the Awagami mill in Japan, this paper has 300 years of washi papermaking experience behind it. Traditional Japanese fibers such as kozo and gampi are combined to create a paper that adds subtle refinements to finished work. Acid-free and archival, Shiramine Select is suitable for both drawing and printmaking. Four deckle edges. 20-1/2" x 17" sheet. 110 gsm.

NUMBER	EACH	10/EA
A11324-1001	\$8.97	\$8.07

Sumi Painting Paper

Acid-free, not sized. Oriental white rice paper for sumi painting, calligraphy, sketching, and more. 50-sheet, 12-1/8" x 18-1/8" pad.

NUMBER	EACH	12/EA
A12952-1006	\$19.74	\$17.77

11" x 60-ft Roll

NUMBER	EACH	12/EA
A12952-1022	\$19.99	\$17.99

Japanese Paper 10-Sheet Assortment

Two full sheets of Kinwashi, Okawara, Unryu, Kitakata, and Mulberry. Unryu and Mulberry are not sized; the other sheets are sized.

NUMBER	EACH	10/EA
A10420-0009	\$49.34	\$44.41

BLOCK PRINTING



Blick® Masterprinter Block Printing Paper

This soft, white, mottled sulphite paper is excellent for lino block, wood block, and screen printing. Compare the quality, weight, texture, and price with other block print papers! 100-sheet package. 50 lb (74 gsm).

NUMBER	SIZE	EACH	10/EA
A10402-1003	9" x 12"	\$6.63	\$5.95
A10402-1007	12" x 18"	12.20	11.03
A10402-1009	18" x 24"	23.40	21.06



Subi Block Printing Paper

A sturdy, smooth printing paper, ideal for all kinds of printmaking using oil-based or waterbased inks. Available in an 100-sheet package of White or a 40-sheet package of assorted colors. 80 lb.

NUMBER	COLOR	SIZE	EACH	6/EA
A10406-1003	White	9" x 12"	\$11.57	\$10.41
A10406-1023	Asst	9" x 12"	10.50	9.45

BFK Rives® Papers

Mouldmade in France with a smooth, absorbent surface, this 100% cotton paper is acid-free, pH-neutral, soft-sized, and buffered. Each sheet is watermarked with two natural deckle and two tear deckle edges. All Rives papers are suitable for pencil, charcoal, colored ink, and silk screening. They are also excellent for lithography, etching, and book binding.

77 lb (115 gsm)

NUMBER	COLOR	SIZE	EACH	25/EA	100/EA
A10419-1111	Cream	20" x 26"	\$4.34	\$3.91	\$3.71
A10419-1011	White	20" x 26"	4.34	3.91	3.71
A10419-1108	Cream	26" x 40"	7.11	6.40	6.08
A10419-1018	Cream	26" x 40"	7.11	6.40	6.08

92 lb (250 gsm), 22" x 30" Sheet

NUMBER	COLOR	SIZE	EACH	25/EA	100/EA
A10419-1002	White		\$5.99	\$5.43	\$5.16

100 lb (270 gsm), 29-1/2" x 41" Sheet

NUMBER	COLOR	EACH	25/EA	100/EA
A10419-1016	White	\$16.27	\$14.64	\$13.91

105 lb (280 gsm), 22" x 30" Sheet

NUMBER	COLOR	EACH	25/EA	100/EA
A10419-2022	Black	\$8.20	\$7.38	\$6.99
A10419-1102	Cream	9.89	8.90	8.45
A10419-2222	Gray	9.89	8.90	8.45
A10419-1032	White	9.89	8.90	8.45
A10419-8232	Tan	9.89	8.90	8.45

118 lb (175 gsm)

NUMBER	COLOR	SIZE	EACH	25/EA	100/EA
A10419-1101	Cream	20" x 26"	\$4.23	\$3.81	\$3.62
A10419-1001	Cream White	20" x 26"	4.23	3.81	3.62
A10419-1106	Cream	26" x 40"	9.42	8.48	8.06
A10419-1006	Cream White	26" x 40"	9.42	8.48	8.06

Roll — 110 lb (300 gsm), 42" x 10 yd

NUMBER	EACH	2/EA	4/EA
A10419-1042	\$205.17	\$184.65	\$175.42



Legion™ Coventry Rag Paper

Coventry is one of the most versatile papers and can be used for all fine art techniques. Machine-made in the USA of 100% cotton, this paper is pH-neutral and deckled on two edges. 22" x 30". 110 lb (290 gsm).

NUMBER	EACH	10/EA
A10438-1002	\$6.12	\$5.51

Canson® Edition Papers

These luxurious, 100% cotton, acid-free papers deliver excellent performance. Each versatile, acid-free sheet features two distinct surfaces, one smooth and one slightly textured, providing exceptional versatility for printmaking, drawing, and multi-media expression. Two deckle edges.

250 gsm

NUMBER	COLOR	SIZE	EACH	25/EA
A10453-1412	Antique White	22" x 30"	\$4.06	\$3.65
A10453-1152	Bright White	22" x 30"	4.06	3.65
A10453-1414	Antique White	30" x 44"	6.83	6.15
A10453-1154	Bright White	30" x 44"	6.83	6.15



Stonehenge® Multi Pads & Rolls

Different types of drawings require different colors of paper. Stonehenge has met this challenge by combining the Stonehenge palette into one versatile pad. A traditional fine art paper with a smooth, flawless surface that is slightly mottled to resemble actual vellum, Stonehenge paper is ideal for watercolors, pen-and-ink, pencils, pastels, and printmaking. Each Multi Pad contains 15 sheets of paper, three sheets each of Warm White, Natural, Cream, Fawn, and Pearl Gray. 90 lb (250 gsm).

NUMBER	SIZE	EACH	6/EA
A12499-1000	5" x 7"	\$12.34	\$11.10
A12499-1023	9" x 12"	21.96	19.76
A12499-1005	11" x 14"	30.36	27.32

Rolls — Available in a variety of colors, Stonehenge rolls let you decide the size of paper you need. Machine-made in the USA from 100% cotton. Rolls measure 50" x 10 yds. 90 lb (250 gsm).

NUMBER	COLOR	EACH	6/EA
A10462-2050	Black	\$281.95	\$253.75
A10462-1100	Cream	207.03	186.33
A10462-8830	Fawn	215.26	193.73
A10462-2500	Gray	215.26	193.73
A10462-1350	Natural	207.03	186.33
A10462-1780	Warm White	207.03	186.33
A10462-1040	White	207.03	186.33



Stonehenge® Lightweight Sketch Pads

This 100% cotton, acid-free, machine-made paper rivals European mouldmade papers, producing excellent results when used for drawing and printmaking. It can accept multiple layers of wax-based and oil-based colored pencil without buildup, allowing colors to penetrate and be absorbed into the sheet. Also excellent with graphite, charcoal, pastels, and watercolors. 50 lb (135 gsm). 30-sheet pads.

NUMBER	SIZE	EACH	12/EA
A13749-1023	9" x 12"	\$15.46	\$13.92
A13749-1005	11" x 14"	24.06	21.63

Stonehenge® Papers

A traditional acid-free fine art paper with a smooth, flawless surface. Stonehenge can be used for a variety of applications: watercolor, printmaking, pen-and-ink, pencil, and pastel, but it's most ideal for colored pencil. Machine-made in the USA from 100% cotton with two deckle edges. 90 lb (250 gsm). Acid-free.

NUMBER	COLOR	SIZE	EACH	25/EA
A10423-2002	Black	22" x 30"	\$5.05	\$4.54
A10423-1102	Cream	22" x 30"	5.07	4.56
A10423-8852	Fawn	22" x 30"	4.61	4.15
A10423-2222	Gray	22" x 30"	4.61	4.15
A10423-8332	Kraft	22" x 30"	5.05	4.54
A10423-1372	Natural	22" x 30"	5.07	4.56
A10423-1192	Polar White	22" x 30"	5.07	4.56
A10423-2622	Steel Gray	22" x 30"	4.61	4.15
A10423-1782	Warm White	22" x 30"	5.07	4.56
A10423-1002	White	22" x 30"	5.07	4.56
A10423-1006	White	26" x 40"	8.08	7.27
A10423-1786	Warm White	30" x 44"	7.27	6.55
A10423-1366	White	30" x 44"	7.27	6.55
A10423-1026	White, 120 lb	30" x 44"	9.84	8.86
A10423-1016	White	38" x 50"	10.65	9.58

Speedball® Printmaster® Paper Packs

For block printing and other printing and stamping applications. Machine-made (85 gsm), true to characteristics of traditional Oriental block paper. Won't yellow or affect other surfaces adversely. Acid-free and pH-neutral.

50-Sheet Pack

NUMBER	SIZE	EACH	6/EA	12/EA
A10431-1023	9" x 12"	\$13.44	\$12.10	\$11.50
A10431-1006	12" x 18"	25.19	22.67	21.55
A10431-1009	18" x 24"	36.70	33.03	31.40

100-Sheet Pack

NUMBER	SIZE	EACH	6/EA	12/EA
A10431-1123	9" x 12"	\$23.38	\$21.05	\$19.99

Pescia Paper by Magnani®

A wonderful printmaking paper with a velvety smooth surface for stone lithography, etchings, woodcut, or silkscreen as well as drawing, charcoal, or pastel work. Mouldmade in Italy from 100% cotton, it is chlorine-free, neutral pH with two natural deckles and two tear deckles. 22" x 30" sheet, 140 lb (300 gsm). Colors can be assorted for quantity pricing.

NUMBER	COLOR	EACH	100/EA
A10436-1102	Cream	\$6.84	\$6.15
A10436-2222	Gray	6.84	6.15
A10436-1012	Soft White	6.84	6.15
A10436-1022	White	6.84	6.15

Domestic Etching Paper

This paper is machine-made in the USA with 50% cotton fibers. Warm white in color and acid-free, it accepts all printmaking and drawing techniques. 80 lb (175 gsm). 26" x 40" sheets.

NUMBER	EACH	25/EA	50/EA
A10421-1005	\$3.99	\$3.70	\$3.51

Zerkall™ Copperplate Paper

Zerkall of Germany has been producing fine artist and printmaking papers since the 16th century. An affordable, solid choice for most printmaking processes. Copperplate is mouldmade with two natural deckles and two tear deckles from a 25% cotton/75% sulphite blend. Unsized, neutral pH, good resistance to oxidization. 22" x 30" sheet (250 gsm). White.

NUMBER	EACH	25/EA	50/EA
A10435-1022	\$6.06	\$5.46	\$5.19

Fabrizio® Unica Printmaking Paper

In collaboration with a prominent printmaking research facility, Fabrizio is proud to introduce Unica, a versatile paper for all printmaking applications, as well as drawing and light water media. This acid-free, environmentally friendly sheet contains 50% cotton content, and is produced using hydro-energy. Flexible and resistant, it has excellent detail definition and high color fidelity. Both students and aspiring artists will appreciate its affordability. 250 gsm.

22" x 30" Sheets

NUMBER	COLOR	EACH	10/EA
A14005-1022	White	\$2.79	\$2.51
A14005-1042	Ivory	2.79	2.51

8-1/2" x 11-3/4", 20-Sheet Pad

NUMBER	COLOR	SIZE	EACH	5/EA
A14005-1028	White		\$16.84	\$15.16

Speedball® Arnhem 1618 Printmaking Paper

A 100% rag, acid-free printmaking paper made in Holland, this paper has a semi-smooth, vellum surface with a substantial feel. Strong, highly absorbent fibers accept multiple layers of ink, making it ideal for dry or damp printing. Both internally and externally sized, its subtle grain is suitable for a wide range of printmaking techniques and media, as well as for intricate details. Available by the sheet, with two deckle edges.

90 lb (245 gsm)

NUMBER	COLOR	SIZE	EACH	25/EA
A10485-1022	White	22" x 30"	\$4.07	\$3.66
A10485-1020	White	26" x 40"	6.13	5.52
A10485-1026	White	30" x 44"	7.61	6.85
A10485-1021	White	38" x 50"	11.18	10.07
A10485-1782	Warm White	22" x 30"	4.07	3.66
A10485-1786	Warm White	30" x 44"	7.61	6.85

90 lb (245 gsm) — Pack of 100

NUMBER	COLOR	SIZE	EACH	25/EA
A10485-1010	White	8-1/2" x 11"	\$56.66	\$50.99

120 lb (320 gsm)

NUMBER	COLOR	SIZE	EACH	25/EA
A10485-1032	White	22" x 30"	\$7.26	\$6.54
A10485-1036	White	30" x 44"	11.42	10.28

Lenox Cotton Drawing Paper

The textured finish of this fine art paper makes it ideal for silkscreen work, offset lithography, etching, embossing, pastel, charcoal, and pencil drawing. Machine-made in the USA of 100% cotton; neutral pH, no deckles. 90 lb (250 gsm).

NUMBER	SIZE	EACH	10/EA	25/EA
A10426-1001	22" x 30"	\$4.03	\$3.63	\$3.45

15-Sheet Pads

NUMBER	SIZE	EACH	12/EA
A13752-1000	5" x 7"	\$9.70	\$8.73
A13752-1023	9" x 12"	19.16	17.25
A13752-1005	11" x 14"	25.61	23.05

Somerset™ Printmaking Paper

Somerset is the standard of excellence for printmaking papers and the choice of artisans and printmakers worldwide. It is equally superior for drawing, charcoal, or pastel. Mouldmade of 100% cotton, it is pH-neutral, chlorine-free, internally and surface-sized, and has two natural and two tear deckles. 22" x 30" sheets. Colors can be assorted for quantity pricing.

Satin Finish

NUMBER	COLOR	WEIGHT	EACH	25/EA	100/EA
A12203-1092	Soft White	300 gsm	\$9.79	\$8.82	\$8.38
A12203-1012	White	300 gsm	9.79	8.82	8.38

Velvet Finish

NUMBER	COLOR	WEIGHT	EACH	25/EA	100/EA
A12203-1412	Antique	250 gsm	\$8.04	\$7.23	\$6.88
A12203-1172	Buff	250 gsm	8.04	7.23	6.88
A12203-2732	Gray	250 gsm	8.04	7.23	6.88
A12203-1082	Radiant White	250 gsm	8.04	7.23	6.88
A12203-1072	Soft White	250 gsm	8.04	7.23	6.88
A12203-1062	White	250 gsm	8.04	7.23	6.88

Arches® Cover

Mouldmade in France specifically for printmaking and publishing, Arches Cover has a pronounced finish, two watermarks, two natural edges, and two tear deckle edges. This 100% cotton paper is acid-free, pH-neutral, internally sized, and buffered.

22" x 30" Sheets — 92 lb (250 gsm).

NUMBER	COLOR	EACH	10/EA
A10417-2002	Black	\$8.53	\$7.68
A10417-1162	Cream	6.09	5.48
A10417-1012	White	6.13	5.52

29" x 41" Sheets — 100 lb (270 gsm).

NUMBER	COLOR	EACH	10/EA
A10417-1006	White	\$14.84	\$13.36



Black Ink™ Block Printing Packs

These Thai-made printing papers are thin yet very strong, making them ideal for lino block printing, wood block printing, and silk screening. They're smooth on one side and lightly textured on the other. The bleached white and colored sheets are made of 100% kozo. The unbleached white sheets are made from a mix of kozo and bamboo. All sheets are 9" x 12", 45 gsm, and pH-neutral. 25-sheet packs.

NUMBER	DESCRIPTION	EACH	10/EA
A10449-6603	Bleached Mulberry	\$19.78	\$17.80
A10449-6613	Unbleached Mulberry	19.78	17.80

Assortment Packs — 24-sheet pack includes three each of Tea, Pear, Sky, Red, Purple, and Mustard, plus six Black sheets. 45-sheet packs contain five each of colors listed above, plus five each bleached and unbleached sheets.

NUMBER	DESCRIPTION	EACH	10/EA
A10449-1004	24 Sheets	\$19.78	\$17.80
A10449-1005	45 Sheets	34.62	31.16



A

A Strathmore® 300 Series Lightweight Printmaking Paper

This lightweight natural white paper is ideally suited for relief printing (such as block or linocut), plus practicing and proofing. It has a high alpha-cellulose wood content, and its medium-texture surface is soft, durable, and can absorb large amounts of ink. The pads feature easy-to-use flip-over covers that allow the sheets to tear out cleanly. 120 gsm.

NUMBER	DESCRIPTION	SIZE	EACH	12/EA
A13824-1000	40-Sheet Gluebound Pad	5" x 7"	\$6.63	\$5.97
A13824-1012	40-Sheet Gluebound Pad	8" x 10"	10.67	9.60
A13824-1005	30-Sheet Gluebound Pad	11" x 14"	15.99	14.39
A13824-1009	30-Sheet Gluebound Pad	18" x 24"	33.36	29.99



B

B Strathmore® 400 Series Heavyweight Printmaking Paper

This heavyweight natural white paper is ideally suited for printmaking processes that require a heavier paper such as lithography, intaglio, screen printing, and relief printing. Its medium-texture surface is soft, durable, and can absorb large amounts of ink. It has a high alpha-cellulose wood fiber content. Choose pads in ready-to-frame sizes, or full-size sheets. 280 gsm.

NUMBER	DESCRIPTION	SIZE	EACH	12/EA
A13825-1000	20-Sheet Pad	5" x 7"	\$7.05	\$6.34
A13825-1012	20-Sheet Pad	8" x 10"	12.19	10.97
A13825-1005	15-Sheet Pad	11" x 14"	17.75	15.99
A13825-1009	15-Sheet Pad	18" x 24"	37.75	33.97
A13825-1003	Sheet	22" x 30"	4.08	3.67



C

C Strathmore® 500 Series RiverPoint® Printmaking Paper

This 100% cotton, archival paper is ideal for a broad array of printmaking applications, including relief, lithography, intaglio, and screen printing. Its natural white, medium-texture surface is soft, durable, and can withstand being soaked prior to printing. Available in full-size sheets with two deckle edges. 280 gsm.

NUMBER	DESCRIPTION	SIZE	EACH	25/EA
A10293-1203	Sheet	20" x 30"	\$6.40	\$5.76

Evolon® AP Paper

Evolon AP is the next generation of non-woven microfiber paper that absolutely loves ink! Made from pure polyester and nylon (with no additives), it requires very limited dampening and absorbs water rapidly. It's tearproof and lint-free — and it won't stretch on the press or expand when wet. Available in two weights and two sizes, by the sheet or by the pack.

98 gsm				
NUMBER	DESCRIPTION	SIZE	EACH	10/EA
A10482-2298	Sheet	22" x 30"	\$5.55	\$4.99
A10482-1098	15-pack	8-1/2" x 11"	16.53	14.87

168 gsm				
NUMBER	DESCRIPTION	SIZE	EACH	10/EA
A10482-2168	Sheet	22" x 30"	\$9.53	\$8.58
A10482-1168	10-pack	8-1/2" x 11"	16.53	14.87

Arches® 88 Silk Screen Paper

Mouldmade in France, this clear, white paper is recommended for screenprinting and, if slightly moistened, for intaglio. Arches 88 is a heavyweight (140 lb) 100% cotton fiber paper. It's acid-free, neutral pH, buffered, and unsized for high absorption. Each sheet is watermarked and has two natural deckle edges.

NUMBER	EACH	25/EA
A10424-1002	\$11.05	\$9.94

Cosmos Blotting Paper

This acid-free, lignin-free, wood-fiber paper has a slight texture, and is heavy and very absorbent. White, 360 gsm.

NUMBER	EACH	25/EA
A10422-1005	\$6.63	\$5.97



Hahnemühle® Copperplate Paper

Available in two colors, Bright White and Warm White, Hahnemühle Copperplate Paper is ideal for a variety of techniques, including drawing, embossing, etching, iris printing, and lithography. This 300 gsm, 100% alpha cellulose paper has a vellum surface with a watermark.

NUMBER	COLOR	SIZE	EACH	25/EA
A10454-1152	Bright White	22" x 30"	\$6.25	\$5.62
A10454-1153	Bright White	31-1/2" x 47"	13.99	12.59
A10454-1882	Warm White	22" x 30"	6.25	5.62
A10454-1883	Warm White	31-1/2" x 47"	13.99	12.59

Awagami Editioning Paper

More than 300 years of washi papermaking expertise at the Awagami mill in Japan go into every sheet of Awagami Editioning Paper. Made from traditional Japanese fibers, this paper is suitable for a wide range of techniques. Each 17" x 20-1/2" sheet has specific characteristics and suggested uses. For details, visit DickBlick.com.

NUMBER	DESCRIPTION	WEIGHT	EACH	25/EA
A11333-1017	Bamboo Select	170 gsm	\$8.97	\$8.07
A11333-1070	Bunkoshi Select	70 gsm	5.73	5.16
A11333-1022	Hakuho Select	220 gsm	12.50	11.25
A11333-1080	Hosho Select	80 gsm	4.54	4.09
A11333-1036	Kitakata Green	36 gsm	5.73	5.16
A11333-1090	Kitakata Select	90 gsm	8.97	8.07
A11333-1016	Kitakata Select SH	36 gsm	5.73	5.16
A11333-1046	Kozo Natural Select	46 gsm	7.50	6.75
A11333-1051	Okawara Select	51 gsm	5.95	5.35



Richeson Bulk® Printmaking Paper

Available in a variety of sheet sizes and pack sizes, this versatile paper offers big savings while being the perfect surface for lino block printing, wood block printing, etching, sumi painting, monoprinting, bookbinding, stamping, watercolors, mixed media, and more. This acid-free paper is internally and externally sized.

88 lb				
NUMBER	DESCRIPTION	SIZE	EACH	12/EA
A14022-1023	50-Sheet Pack	6" x 9"	\$6.83	\$6.16
A14022-1022	1250-Sheet Pack	6" x 9"	173.12	155.82
A14022-1033	50-Sheet Pack	9" x 12"	12.51	11.26
A14022-1032	625-Sheet Pack	9" x 12"	173.12	155.82
A14022-1051	350-Sheet Pack	12" x 18"	105.73	95.15
A14022-1063	50-Sheet Pack	12" x 18"	21.16	19.05
A14022-1062	350-Sheet Pack	12" x 18"	193.12	173.81

135 lb				
NUMBER	DESCRIPTION	SIZE	EACH	12/EA
A14022-1021	50-Sheet Pack	6" x 9"	\$9.72	\$8.75
A14022-1020	850-Sheet Pack	6" x 9"	172.85	155.57
A14022-1031	50-Sheet Pack	9" x 12"	18.56	16.70
A14022-1030	425-Sheet Pack	9" x 12"	172.85	155.57
A14022-1050	250-Sheet Pack	11" x 14"	105.73	95.15
A14022-1061	50-Sheet Pack	12" x 18"	31.27	28.11
A14022-1060	250-Sheet Pack	12" x 18"	193.12	173.81

SCRATCH ART



new!

NEW! Ooly Scratch and Scribble Mini Scratch Art Kit

Kids will love scratching and scribbling these coated sheets to reveal hidden characters and designs. Kits include four illustrated 4" x 6" scratch cards, two 4" x 6" rainbow DIY blank scratch cards, one wooden stylus, and guided illustrations.

NUMBER	DESCRIPTION	EACH	12/EA
A67927-1003	Cutie Cats	\$6.55	\$5.89
A67927-1004	Safari Party	6.55	5.89
A67927-1005	Dinosaur Days	6.55	5.89
A67927-1006	Playful Pups	6.55	5.89



Now You See It! Art Cards

Now You See It! Art Cards are perfect for encouraging creativity in young artists. Scratching the black-coated card paper reveals the bright colors underneath. Each 52-card set comes with an etching stick, plus illustration and design ideas. Cards measure 3 1/2" x 2 1/2".

NUMBER	DESCRIPTION	SIZE	EACH	6/EA
A13550-1008	Color Splash	3-1/2" x 2-1/2"	\$6.26	\$5.63



Eeboo Scratch Papers

Beneath the inky black surface of these incredible scratch papers hides colorful patterns and whimsical designs by illustrator Kevin Hawkes. Winner of the Oppenheim Platinum Award. Includes a bamboo stick and 20 sheets, 10 each of two designs. Sheets measure 8" x 8".

NUMBER	DESCRIPTION	EACH	6/EA
A76383-1007	Eeboo Space Scratch Papers	\$17.55	\$15.79



Eeboo Rainbow and Friends Scratch Paper Stickers

Featuring rainbow geometric shapes and tie-dye patterns, kids will love using Eeboo Rainbow and Friends Scratch Paper Stickers to place their designs anywhere. Etching stickers will reveal colors, patterns, and whimsical designs by illustrator Kevin Hawkes. Includes six 5" x 6" sheets of 108 shaped stickers and a bamboo stick. Winner of the Oppenheim Gold Award.

NUMBER	EACH	6/EA
A76383-1006	\$12.05	\$10.84



Krafty Kids DIY Scratch Art

Each set includes three designs and one easy-to-use scratch tool. Children can use the scratch tool on any of the three sheets to bring each character to life and reveal bright colors.

NUMBER	EACH	12/EA
A64311-1002	\$3.15	\$2.83



Scratch-Art® Clear-Scratch™ Film

Scratch a design in these black-coated sheets with a wood stylus to expose the clear film below. Then place a background sheet (colored paper, foil, or other opaque material) behind the scratched design for fascinating effects. Also use as a positive film mask with light-sensitive paper. Instructions included. Sheets are 8" x 9-3/4".

NUMBER	DESCRIPTION	EACH	12/EA
A13524-1030	30 Sheets	\$32.49	\$29.24



Scratch-Art® Light Catchers Group Pack

Includes everything to complete 12 "stained glass" projects: 12 design frames (three each of butterfly, hummingbird, flower, and sailboat), 12 Scratch-Art sheets, 12 stylus tools, and instructions. Personalize each light catcher with unique drawings, then hang them in a window and let the sun shine through!

NUMBER	EACH	6/EA
A13451-1001	\$22.95	\$20.65

new!

NEW! Now You See It! Art Paper

Etch designs into these black-coated papers to reveal the colors underneath. Pads contain 50 papers measuring 8 1/2" x 11" and include an etching stick.

NUMBER	DESCRIPTION	PKG	EACH	6/EA
A13550-1002	Fluorescent Flash	50	\$31.14	\$28.03
A13550-1003	Gold Glimmer	50	32.21	28.99
A13550-1004	Silver Shine	50	32.21	28.99
A13550-1005	Color Splash	30	17.51	15.76
A13550-1006	Radiant Rainbow	50	28.51	25.66
A13550-1007	Metallic Madness	50	31.14	28.03



Scratch-Art® Scratch Tool Pack

Includes 12 holders and 12 curved-edge tips. The triangular shape of the plastic holder provides excellent control and grip. The sharp steel tips are heat-treated to retain sharpness and plated to resist rust.

NUMBER	EACH	12/EA
A13541-1001	\$33.66	\$30.29



Scratch-Art® Scratch Knife Tool Set

An economical and versatile tool that enables artists to create a wide variety of lines. The plastic handle is ergonomically designed and easy to hold; the seven interchangeable knife tips are made from high carbon, heat-treated steel that stays sharp and won't rust.

NUMBER	EACH	6/EA
A14939-1009	\$11.79	\$10.61



Scratch-Art® Scratch Knives

Use with standard pen holders.

NUMBER	DESCRIPTION	EACH	12/EA	36/EA
A14901-0000	Curved	\$1.39	\$1.25	\$1.19
A14901-0010	Straight	1.39	1.25	1.19



Scratch-Art® Knife Holder 12-Pack

Designed specifically for use with scratch knives, but also fits standard dip pen points. Sturdy plastic handle is 5-1/4"L x 5/16"Dia. Pack of 12.

NUMBER	EACH	6/EA	12/EA
A22952-1012	\$10.50	\$9.45	\$8.98



Scratch-Art® Scratch Brush

Texturize quickly, with just a few strokes. Great for grass, bark, hair, fur, or just loose sketching. 6" long wooden handle with eight stainless steel bristles.

NUMBER	EACH	12/EA	24/EA
A14908-0000	\$4.63	\$4.17	\$3.96



Speedball® Standard Pen Holder

6-1/2" long, black plastic holder fits all standard pen points, scratch knives, and lino cutters. (Nib not included. Not for quills or fine point nibs.)

NUMBER	EACH	12/EA
A20914-1065	\$1.94	\$1.75



Scratch-Art® Scratch-Etch Stylus 12-Pack

Create scrimshaw effects with this precision tool featuring a 4-1/2" varnished wooden handle and protruding metal point (blunted for safety). Pkg of 12.

NUMBER	EACH	6/EA
A64307-1012	\$18.27	\$16.44



Scratch-Art® Scratch Stick Packs

A bag of 100 wooden styluses, sharply pointed for use with scratch paper. 4-1/2" long.

NUMBER	EACH	3/EA	6/EA
A14907-1045	\$9.73	\$8.76	\$8.32

Heavy-Duty Scratch Sticks — 5-1/2" long, heavy-duty hardwood sticks. Extra-durable for repeated use. Pack of 25.

NUMBER	EACH	12/EA	24/EA
A22883-1025	\$5.49	\$4.94	\$4.69



Scratch-Art® Paper

Scratch art for young students. The paper is black-coated over white or bright, solid colors. Remove coating with scratch tool and color shows through. Sheets measure 8-1/2" x 11".

White				
NUMBER	DESCRIPTION	EACH	6/EA	
A13509-1039	50 Sheets, plus instructions	\$33.14	\$29.83	



Solid Color Assortment — Includes Red, Yellow, Blue, Green, Pink, and White.

NUMBER	DESCRIPTION	EACH	6/EA
A13509-8609	60 Sheets, plus instructions	\$35.74	\$32.17

Multicolor — Features 6 different colors on each sheet. Includes complete instructions. 8-1/2" x 11".

NUMBER	DESCRIPTION	EACH	24/EA
A13501-2085	50 Sheets	\$37.12	\$33.41

Gold-Silver Foil — Comes with sheets of Gold and Silver and complete instructions. 8-1/2" x 11".

NUMBER	DESCRIPTION	EACH	24/EA
A13501-8515	50 Sheets	\$44.49	\$40.04

Rainbow White — Scratch away the white surface coating of the paper to expose a rainbow of colors! Each package includes complete instructions. 8-1/2" x 11".

NUMBER	DESCRIPTION	EACH	24/EA
A13501-1011	50 Sheets	\$42.52	\$38.27



Essdee™ Commercial Scratchboards

The standard of excellence in a scratchboard. Each board is handmade to ensure a hard, smooth, and heavy white coating that permits clean and precise engravings. Available in Black pre-inked and White un-inked. 12 pt thickness.

NUMBER	COLOR	SIZE	EACH	10/EA
A13502-2007	Black	19" x 12"	\$11.03	\$9.91
A13502-1007	White	19" x 12"	9.91	8.92
A13502-2001	Black	19" x 24"	20.94	18.84
A13502-1001	White	19" x 24"	18.73	16.86



Glitter



Multicolor Glitter

Scratch-Art® Scratch & Sparkle® Board

Create the most sparkling Scratch-Art pictures ever! Simply scratch with the wooden scratch tool to reveal the glittering holographic films beneath the surface. Pictures reflect light and produce sparkling prismatic colors. Instructions included. 8-1/2" x 11" sheets.

NUMBER	DESCRIPTION	PKG	EACH	6/EA
A13520-1030	Glitter	30	\$46.39	\$41.75
A13520-1130	Multicolor Glitter	30	43.29	38.96



Scratch-Art® Multicolor Scratchboard

Scratch through the black coating and an array of colors appears. The under layer is comprised of six different colors. Instructions included. 8-1/2" x 11" boards.

NUMBER	DESCRIPTION	EACH	12/EA
A13534-1030	30	\$27.99	\$25.19



Gold



Silver

Scratch-Art® Scratch-Brite® Gold or Silver Scratchboards

Impressive details are possible with this shiny metallic color printed on a heavy board base. The reflective color contrasts beautifully against the rich black background. It withstands deep scratching. Pre-inked black. 8-1/2" x 11".

Gold Scratch-Brite			
NUMBER	PKG	EACH	3/EA
A13516-9012	50	\$57.75	\$51.97

Silver Scratch-Brite			
NUMBER	PKG	EACH	3/EA
A13516-1095	50	\$53.33	\$47.99

SCRATCH-ART®



Scratch-Art® Pre-Inked Black Scratchboard

A student-grade scratchboard with a clay and polyester coating, covered in an opaque black ink. 12 pt thickness.

NUMBER	SIZE	EACH	25/EA
A13506-2085	8-1/2" x 11"	\$.84	\$.76
A13506-2005	11" x 14"	1.45	1.30
A13506-2002	22" x 28"	4.29	3.86

Pack of 10			
NUMBER	SIZE	EACH	6/EA
A13538-2000	8-1/2" x 11"	\$7.94	\$7.15

Pack of 12			
NUMBER	SIZE	EACH	6/EA
A13538-2005	11" x 14"	\$14.99	\$13.49



Scratch-Art® Scratch-Foam® Soft Surface Printing Board

Kids don't need to use sharp tools! A pencil, lollipop stick, or ballpoint pen "cuts" this block with ease. It's economical and easy to work with — the perfect way to introduce young students to printing.

NUMBER	SIZE	PKG	EACH	12/EA
A13519-0012	9" x 12"	12	\$12.99	\$11.69
A13519-1069	6" x 9"	30	18.40	16.56
A13519-0048	9" x 12"	48	39.32	35.39



Moab™ Entrada™ Textured Rag Paper Pads

This 100% cotton, 300 gsm (22.5 mil), archival fine art paper is acid-free and lignin-free with an expanded color gamut that provides natural contrast and accepts a high ink load. Compatible with both dye and pigment inks, it has a subtle texture and warm tone that exhibit the same superb printing qualities of Moab's smooth surface Entrada Rag, with the same wide tonal range and high dMax. Its defined yet subtle texture and natural warm surface enhance the printed image without being distracting. 25-sheet pads.

NUMBER	SIZE	EACH
A10537-1085	8-1/2" x 11"	\$39.11
A10537-1019	13" x 19"	281.91
A10537-1022	17" x 22"	142.74

Moab™ Juniper Baryta Rag Paper

This double-weight coated inkjet fine art paper embraces the unique charm of silver halide by using state-of-the-art coating technology to bring a new method to an old tradition. A white, 100% cotton, true baryta (barium sulfate) fiber paper with a glossy surface texture, it offers the density of a traditional darkroom FB-type paper to hold detail in the deep blacks, while producing natural white highlights. 16 mil (305 gsm). Made in the USA.

NUMBER	SIZE	EACH
A10538-1022	8-1/2" x 11"	\$41.32
A10538-1026	13" x 19"	98.64

Moab™ Entrada Rag Paper

Entrada 100% cotton, smooth, double-sided papers are beautiful surfaces for fine art prints that will last a lifetime. The Bright White sheet reproduces vivid color and maximum contrast for exceptionally detailed prints. Natural is a soft white sheet created with no optical brighteners and is ideal for black-and-white images. Bright White and Natural are both compatible with dye or pigmented inks. 25-sheet pads.

190 gsm			
NUMBER	COLOR	SIZE	EACH
A12536-1161	Bright White	8-1/2" x 11"	\$42.35
A12536-1167	Bright White	11" x 17"	86.39
A12536-1169	Bright White	13" x 19"	105.35
A12536-1381	Natural	8-1/2" x 11"	42.35
A12536-1387	Natural	11" x 17"	86.39
A12536-1389	Natural	13" x 19"	105.35

300 gsm			
NUMBER	COLOR	SIZE	EACH
A12536-1151	Bright White	8-1/2" x 11"	\$45.69
A12536-1157	Bright White	11" x 17"	89.74
A12536-1159	Bright White	13" x 19"	109.82
A12536-1371	Natural	8-1/2" x 11"	45.69
A12536-1377	Natural	11" x 17"	89.74
A12536-1379	Natural	13" x 19"	109.82



Moab™ Slickrock Metallic Silver

Slickrock Metallic Silver is an ultra-shiny, true metallic paper with a unique instant-dry coating for vivid image reproduction and images that jump off the paper. Compatible with both dye and pigment inks, this 12 mil, 300 gsm, acid-free paper is ideal for both fine art and everyday image reproduction, and can be handled immediately after printing.

NUMBER	SIZE	SHEETS	EACH
A11990-1000	5" x 7"	50	\$33.29
A11990-1811	8-1/2" x 11"	25	39.84
A11990-1319	13" x 19"	25	105.70

Moab™ Lasal Photo Paper Packs

Lasal is a professional-grade digital photo paper that offers brilliant whiteness, excellent image sharpness, and good color density. 50-sheet packs.

Lasal Photo Matte — A water-resistant, instant-dry paper that is double-sided with a smooth, matte surface. 235 gsm.

NUMBER	DESCRIPTION	EACH
A10428-1042	8-1/2" x 11"	\$36.11
A10428-1047	11" x 17"	61.92

Lasal Luster 300 — A crisp, white, heavyweight, archival-quality luster paper designed for use with inkjet printers. 300 gsm.

NUMBER	DESCRIPTION	EACH
A12563-1020	8-1/2" x 11"	\$48.57
A12563-1027	11" x 17"	99.73
A12563-1029	13" x 19"	119.79

Moab™ Somerset Photo Enhanced Velvet Paper

The answer for artists who demand crisp "photo-quality" reproduction without sacrificing the luxurious feel of fine art paper. This radiant white paper, combined with high-quality ink, yields spectacular results, exceptional depth, and rich, vivid colors that grab the eye. 25-sheet packs. 225 gsm.

NUMBER	SIZE	EACH
A10428-0012	8-1/2" x 11"	\$61.11

Moab™ Slickrock Metallic Pearl

Slickrock Metallic Pearl captures the original beauty of an image while enhancing it with a slightly metallic pearl look. This microporous paper has a glossy surface with instant dry time. The 12 mil, 260 gsm sheets are acid-free, water-resistant, and compatible with both dye and pigment inks.

NUMBER	SIZE	SHEETS	EACH
A11989-1000	5" x 7"	50	\$29.99
A11989-1851	8-1/2" x 11"	25	35.99
A11989-1319	13" x 19"	25	99.90



Boogie Board™ eWriter

Eliminate the need for paper, scratch pads, dry erase boards, and sticky notes with the Boogie Board line of eWriters! The Jot 4.5 lets you write and erase again and again without the need to charge or connect. Make lists, brainstorm, doodle! A 50% brighter screen on the Jot 8.5 creates lines that are almost luminescent, and the free Jot app allows you to save, edit, and share your drawings, lists, notes, and doodles with others. Both models provide the natural feel of writing with a pen on paper, while using a stylus on an LCD screen. No matter where you are — in the studio, office, home, or on-the-go — there's a Boogie Board for you! For additional product details, visit DickBlick.com.

NUMBER	DESCRIPTION	SCREEN SIZE	EACH
A22796-2504	Jot 4.5	2-3/4" x 3-1/2"	\$16.37
A22796-2508	Jot 8.5	5" x 7"	27.29



Strathmore™ Artist Inkjet Paper and Photo Paper

Strathmore has developed the perfect papers to produce long-lasting works of art using today's technology.

Texture — Print pastel or watercolor artwork with a light textured appearance. Fluorescent White, 8-1/2" x 11", 80 lb (216 gsm), 25-Sheet Pack.

NUMBER	EACH	12/EA
A12954-1012	\$13.19	\$11.87

Glossy — Works in all inkjet printers. 8-1/2" x 11" Sheets are precut to fit standard size mats and frames. Acid-free; lignin-free. 15-Sheet Pack

NUMBER	EACH	12/EA
A12534-1001	\$11.70	\$10.53

Matte — Works in all inkjet printers. Packs of 8-1/2" x 11" paper contain 15 sheets. Acid-free; lignin-free.

NUMBER	EACH	12/EA
A12534-1011	\$11.70	\$10.53

Watercolor — Replicate watercolor works with this medium-texture, cold press paper. Acid-free, lignin-free, and compatible with all inkjet printers. 8-1/2" x 11", 140 lb (315 gsm), 8-Sheet Pack.

NUMBER	EACH	12/EA
A12954-2085	\$21.18	\$19.06

Strathmore™ Inkjet Translucent Vellum

This beautiful translucent vellum is just the thing to transform ordinary cards, letters, invitations, scrapbooks, or documents. This premium paper is designed for high-quality color inkjet printing.

NUMBER	EACH	12/EA
A12954-1185	\$8.56	\$7.70



A-E Inkpress™ Inkjet Paper

These quality papers from Inkpress are compatible with all inkjet printers.

A Inkpress Proofing Matte — A single-sided, white matte finish paper that's extremely economical and perfect for everyday printing at resolutions up to 2880 dpi. Good ink absorption, with excellent sharpness and color gradation. Fast-drying and lightfast, it's also acid-free and lignin-free. 90 gsm.

NUMBER	SIZE	SHEETS	EACH	10/EA
A12540-1085	8-1/2" x 11"	250	\$41.58	\$37.42
A12540-1017	11" x 17"	100	31.78	28.60

B Inkpress Matte 60 — A single-sided, white matte finish, suitable for high-resolution printing up to 5760 dpi. It offers extremely good pigment and dye absorption, dries instantly, and is water-resistant, lightfast, acid-free, and lignin-free. 200 gsm.

NUMBER	SIZE	SHEETS	EACH	10/EA
A12541-1085	8-1/2" x 11"	50	\$14.99	\$13.49
A12541-1019	13" x 19"	50	41.88	37.69

C Inkpress Glossy — A premium-quality, heavyweight, resin-coated paper with a real photo feel. It offers extremely high resolution up to 5760 dpi with sharp details and brilliant colors. Dries instantly — no smudges or smears. Lightfast. 240 gsm.

NUMBER	SIZE	SHEETS	EACH	10/EA
A12542-1085	8-1/2" x 11"	50	\$30.19	\$27.17
A12542-1019	13" x 19"	20	47.39	42.65

D Luster — A premium-quality, high-resolution bright white photo-grade paper designed for the highest-quality color images on both dye and pigment inkjet printers. Its microporous, ultra-absorbent resin coating allows UltraChrome and other pigmented inks to dry instantly. 240 gsm.

NUMBER	SIZE	SHEETS	EACH	10/EA
A12553-1011	8-1/2" x 11"	50	\$30.19	\$27.17
A12553-1019	13" x 19"	20	46.73	42.06

E Pro Silky — An outstanding surface that allows handling without fingerprints or artifacts. Gloss and surface reflectance of the silky finish remains the same in printed and unprinted areas when using pigmented or dye inks. 300 gsm.

NUMBER	SIZE	SHEETS	EACH	10/EA
A12554-1011	8-1/2" x 11"	50	\$32.32	\$29.09
A12554-1019	13" x 19"	20	50.22	45.21

F Inkpress™ Metallic Satin

This paper yields the kind of stunning results that previously could only be achieved in the darkroom. Featuring a high-gloss surface that's compatible with dye-based and pigment-based inks, Metallic Satin creates prints that are sharp, vibrant, and exceptionally rich looking, making it ideal for portraits, commercial display prints, and competition prints. This paper's instant-dry, scratch-resistant surface also makes it practical for everyday use in a busy studio. Individual sheets measure 10 mil thick. 255 gsm. 20-sheet pack.

NUMBER	EACH	10/EA
A12562-1085	\$40.78	\$36.70

G Inkpress™ Adhesive Luster

Compatible with all inkjet printers, this 9.5 mil thick, 240 gsm paper is bright white with a pearl finish and an adhesive backing. It reproduces vibrant photo-realistic images that are true in color, with soft gradients and excellent contour definition. Other features include a PE extruded microporous coating and a silicon release liner. The adhesive backing on this fast-drying paper makes it ideal for short-term indoor promotions. Three sizes, 20 sheets per pack.

NUMBER	SIZE	EACH	10/EA
A12575-1085	8-1/2" x 11"	\$35.27	\$31.74
A12575-1011	11" x 17"	66.13	59.53
A12575-1013	13" x 19"	78.43	70.59

Inkpress™ Rag

A double-sided, 100% cotton rag paper that is acid-free and archival, Inkpress Rag is ideal for professional photographic digital printing of fine art. The paper's especially bright white coating allows for excellent color and black-and-white reproduction. Its light-resistant and water-resistant properties also allow artists to enhance, spot, retouch, or airbrush their work. Both the paper and coating are manufactured at Monadnock Paper Mill — the most experienced paper mill in the USA — assuring consistency and quality. 25-sheet pads.

Cool Tone

NUMBER	SIZE	WEIGHT	EACH	10/EA
A10539-1011	8-1/2" x 11"	200 gsm	\$20.76	\$18.68
A10539-1019	13" x 19"	200 gsm	52.53	47.28
A10539-1111	8-1/2" x 11"	300 gsm	24.88	22.39
A10539-1119	13" x 19"	300 gsm	62.49	56.24

Warm Tone

NUMBER	SIZE	WEIGHT	EACH	10/EA
A10539-1211	8-1/2" x 11"	200 gsm	\$20.76	\$18.68
A10539-1219	13" x 19"	200 gsm	52.53	47.28
A10539-1311	8-1/2" x 11"	300 gsm	24.88	22.39
A10539-1319	13" x 19"	300 gsm	62.49	56.24

Grafix™ Computer Film

Give your computer-printed projects a new dimension.

These blank transparent sheets can be easily run through laser/copier or inkjet printers with sharp and vibrant results. Layer images seamlessly, overlay text, create clear pockets, stickers, or printed windows. Grafix Computer Film is perfect for a wide variety of craft, scrapbooking, and paper projects. Acid-free.

Regular

NUMBER	DESCRIPTION	EACH	12/EA
A10917-1600	8-1/2" x 11", 6-pack, Inkjet	\$9.58	\$8.62
A10916-1600	8-1/2" x 11", 6-pack, Laser	9.58	8.62

Adhesive Back

NUMBER	DESCRIPTION	EACH	12/EA
A10917-1610	8-1/2" x 11", 6-pack, Inkjet	\$14.99	\$13.49



Lazertran™ Transfer Papers

This versatile and revolutionary product allows any design, including original art, to be transferred onto almost any surface with amazing results. Unlike heat set transfers, Lazertran is a waterslide transfer paper. The process is simple: photocopy or inkjet copy color images onto Lazertran paper, cut to size, soak in water, and easily slide the transparent decal from the paper backing. Decals can then be applied to wood, paper, stones, glass, metal, candles, walls, clay, fabric, and much more!

NUMBER	DESCRIPTION	EACH	10/EA
A10446-1010	For Photocopiers	\$26.20	\$23.57



Hahnemühle™ Photo Rag Inkjet Paper

This 100% cotton paper has a smooth, fine, matte surface texture that meets the highest industry standards for density, color gamut, color gradation, and image sharpness, while preserving the special touch and feel of genuine art paper. Compatible with pigmented and dye inkjet systems, it can be used for photographic and fine art reproductions, digital art, black-and-white photos, color photos, limited edition prints, presentation prints, albums, greeting cards, and more. 308 gsm. 25-sheet packages.

NUMBER	DESCRIPTION	EACH	10/EA
A12580-1085	8-1/2" x 11"	\$60.20	\$54.18
A12580-1013	13" x 19"	169.12	152.21
A12578-1085	8-1/2" x 11", Deckle Edge	103.75	93.37
A12578-1013	13" x 19", Deckle Edge	262.14	235.93

canson infinity digital papers



Canson® Infinity Digital Papers

A spirit of innovation gained from centuries of papermaking experience has been combined with technically advanced coatings to produce the new benchmark for today's demanding print reproduction marketplace. Only the purest materials and natural minerals are used to create age-resistant inkjet papers with exceptional quality and character, stellar printing performance, consistency, and value. Manufactured by the world's leading fine art paper mills, Canson Infinity papers and canvas are the standard for today's artists and photographers.

Infinity Edition Etching Rag — This museum-grade, mouldmade, 100% cotton paper assures deep blacks, excellent image sharpness, and optimum color gradation. Its slight grain makes it ideal for printing detailed work in both color and black-and-white. 310 gsm.

NUMBER	DESCRIPTION	EACH	12/EA
A12546-1010	8-1/2" x 11", 10-pack	\$20.85	\$18.77
A12546-1025	8-1/2" x 11", 25-pack	46.24	41.62
A12546-1011	11" x 17", 25-pack	95.33	85.80
A12546-1023	13" x 19", 25-pack	133.50	120.20

Infinity PMK Rag — This traditional mouldmade printmaking paper is now available for digital art. Its unique, fine-grained, smooth surface and structure and pure white tone are ideal for photographs and museum-grade fine art printmaking. 310 gsm.

NUMBER	DESCRIPTION	EACH	12/EA
A12545-1025	8-1/2" x 11", 25-pack	\$69.83	\$62.86
A12545-1011	11" x 17", 25-pack	124.92	112.43
A12545-1023	13" x 19", 25-pack	181.45	163.30

Infinity Rag Photographique — A 100% cotton museum-grade white fine art and photo paper. The exceptionally smooth white tone is achieved during manufacturing by introducing natural minerals to the process.

NUMBER	DESCRIPTION	EACH	12/EA
A12551-2110	210 gsm, 8-1/2" x 11", 10-pack	\$19.51	\$17.56
A12551-2125	210 gsm, 8-1/2" x 11", 25-pack	43.16	38.84
A12551-2111	210 gsm, 11" x 17", 25-pack	82.50	74.25
A12551-2123	210 gsm, 13" x 19", 25-pack	131.64	118.47
A12551-2117	210 gsm, 17" x 22", 25-pack	150.96	135.87
A12551-3110	310 gsm, 8-1/2" x 11", 10-pack	23.28	20.96
A12551-3125	310 gsm, 8-1/2" x 11", 25-pack	57.87	52.08
A12551-3111	310 gsm, 11" x 17", 25-pack	99.92	89.92
A12551-3123	310 gsm, 13" x 19", 25-pack	153.81	138.43
A12551-3117	310 gsm, 17" x 22", 25-pack	188.82	169.93

Infinity Rag Photographique Duo — A 100% rag, double-sided, coated paper that offers an exceptionally pure white tone and an extra smooth surface. Among the highest Dmax available, Rag Photographique Duo is compatible with pigmented and dye inks, dries instantly, is water-resistant, and contains no optical brightening agents. Internally buffered and acid-free, it was designed to meet the longevity requirements of galleries and museums. 220 gsm.

NUMBER	DESCRIPTION	EACH	12/EA
A12560-1085	8-1/2" x 11"	\$58.42	\$52.58

Infinity Velin Museum Rag — This mouldmade paper has a unique, fine-grained, smooth surface and structure, and a pure white tone that is ideal for sophisticated photographs, museum-grade applications, and fine art printmaking. Compatible with pigmented and dye inks, it dries instantly, is water-resistant, and contains no optical brightening agents. Internally buffered and acid-free, it was designed to meet the longevity requirements of galleries and museums.

NUMBER	DESCRIPTION	EACH	12/EA
A12544-2510	250 gsm, 8-1/2" x 11", 10-pack	\$25.30	\$22.77
A12544-2525	250 gsm, 8-1/2" x 11", 25-pack	57.38	51.65
A12544-2523	250 gsm, 13" x 19", 25-pack	149.43	134.50
A12544-3125	315 gsm, 8-1/2" x 11", 25-pack	60.67	54.61
A12544-3123	315 gsm, 13" x 19", 25-pack	166.79	150.10



The Slate 2+ and Accessories

The Slate 2+ is the drawing tablet for pencil and paper lovers! Connect it to a tablet, smartphone, or computer and see your drawings come to life on the screen. Just slide the removable iskn ring onto your favorite pencil or pen and draw on any type of paper — even sketchpads up to 7 mm thick — for use with your favorite devices. Enjoy the graphic tablet mode to use it with desktop drawing software. The screen-less mode even lets you use the it without being connected to a device. Compatible with iOS, Android, macOS, and Windows. For more details, visit DickBlick.com.

NUMBER	DESCRIPTION	EACH	6/EA
A22686-1001	Slate 2+	\$178.99	\$161.09
A22686-1004	The Clips	10.82	10.40
A22686-1003	The Tip	21.74	20.90
A22686-1002	The Ring	27.20	26.15

Infinity Aquarelle Rag — This mouldmade watercolor paper possesses the unique structure, surface texture, and warm white tone that demanding artists expect from a traditional fine art paper. Compatible with pigmented and dye inks, it dries instantly, is water-resistant, and contains no optical brighteners.

NUMBER	DESCRIPTION	EACH	12/EA
A12543-2425	240 gsm, 8-1/2" x 11", 25-pack	\$53.96	\$48.58
A12543-2411	240 gsm, 11" x 17", 25-pack	107.94	97.17
A12543-2423	240 gsm, 13" x 19", 25-pack	137.70	123.97
A12543-3125	310 gsm, 8-1/2" x 11-1/4", 25-pack	57.57	51.83
A12543-3111	310 gsm, 11" x 17", 25-pack	115.13	103.65
A12543-3123	310 gsm, 13" x 19", 25-pack	146.80	132.16
A12543-3117	310 gsm, 17" x 22", 25-pack	221.58	199.46
A12543-3150	310 gsm, 17" x 50 ft, Roll	226.77	204.09
A12543-3124	310 gsm, 24" x 50 ft, Roll	308.00	277.62
A12543-3136	310 gsm, 36" x 50 ft, Roll	444.00	399.00
A12543-3144	310 gsm, 44" x 50 ft, Roll	565.00	509.00

Infinity Photosatin Premium RC — An alpha-cellulose art paper coated to give softened reflections on photographs — a great choice for both black-and-white and color photography. 270 gsm.

NUMBER	DESCRIPTION	EACH	12/EA
A12550-1025	8-1/2" x 11", 25-pack	\$26.97	\$24.27
A12550-1011	11" x 17", 25-pack	53.93	48.54
A12550-1024	24" x 100 ft, Roll	166.92	150.20

Infinity PhotoGloss Premium RC — A coated alpha-cellulose art paper that offers a wide color range and sharp, vibrant results with a stunning glossy finish. 270 gsm.

NUMBER	DESCRIPTION	EACH	12/EA
A12549-1025	8-1/2" x 11", 25-pack	\$26.97	\$24.27
A12549-1011	11" x 17", 25-pack	53.93	48.54
A12549-1023	13" x 19", 25-pack	74.58	67.13

Infinity Photo Lustre Premium RC — A true lustre surface with extra white color creates optimal contrast on this premium resin-coated paper. A heavier weight makes Photo Lustre Premium RC heavier than other satin and photo gloss papers. 310 gsm.

NUMBER	DESCRIPTION	EACH	12/EA
A10489-1085	8-1/2" x 11"	\$29.44	\$26.50
A10489-1011	11" x 17"	58.77	52.90
A10489-1023	13" x 19"	77.34	69.61

HEALTH & SAFETY ICONS: ●=CL / ■=Prop 65 / ▼=CL & Prop 65
See page 644 for more information.



Hand Book Artist Journals

Attractive and functional, a hand-bound, bookcloth-covered sketch journal is the perfect travel companion for artists. Each journal features 64 buff-colored blank sheets, a durable elastic closure, and a clear plastic envelope to hold notes or business cards. The heavyweight, acid-free sheets are 130 gsm, with a light, toothy surface that accepts pen-and-ink, pencil, markers, and light watercolor washes without buckling.

NUMBER	COLOR	DESCRIPTION	EACH	6/EA
A11869-7233	Cadmium Green	3-1/2" x 5-1/2", Portrait	\$13.66	\$12.30
A11869-7253	Cadmium Green	5-1/2" x 3-1/2", Landscape	13.66	12.30
A11869-7205	Cadmium Green	5-1/2" x 5-1/2", Square	16.52	14.86
A11869-7234	Cadmium Green	8-1/4" x 5-1/2", Landscape	19.99	17.99
A11869-7238	Cadmium Green	8-1/4" x 5-1/2", Portrait	19.99	17.99
A11869-2233	Ivory Black	3-1/2" x 5-1/2", Portrait	13.66	12.30
A11869-2253	Ivory Black	5-1/2" x 3-1/2", Landscape	13.66	12.30
A11869-2205	Ivory Black	5-1/2" x 5-1/2", Square	16.52	14.86
A11869-2235	Ivory Black	5-1/2" x 8-1/4", Portrait	19.99	17.99
A11869-2250	Ivory Black	8-1/4" x 5-1/2", Landscape	19.99	17.99
A11869-5233	Ultramarine Blue	3-1/2" x 5-1/2", Portrait	13.66	12.30
A11869-5253	Ultramarine Blue	5-1/2" x 3-1/2", Landscape	13.66	12.30
A11869-5205	Ultramarine Blue	5-1/2" x 5-1/2", Square	16.52	14.86
A11869-5238	Ultramarine Blue	8-1/4" x 5-1/2", Portrait	19.99	17.99
A11869-5223	Ultramarine Blue	8-1/4" x 5-1/2", Landscape	19.99	17.99
A11869-3273	Vermilion Red	5-1/2" x 3-1/2", Portrait	13.66	12.30
A11869-3283	Vermilion Red	5-1/2" x 3-1/2", Landscape	13.66	12.30
A11869-3285	Vermilion Red	5-1/2" x 5-1/2", Square	16.52	14.86
A11869-3288	Vermilion Red	8-1/4" x 5-1/2", Portrait	19.99	17.99
A11869-3284	Vermilion Red	8-1/4" x 5-1/2", Landscape	19.99	17.99



Pentatic® Recycled Traveler Sketchbooks

An economical, ecological choice for students, artists, list-makers and note-takers! Recycled, white-colored, acid-free, 74 lb (120 gsm) paper is perfect for pencil, crayon, charcoal, or pastel. Perfect-bound books are stitched in sections to lie flat when writing or sketching. Books contain 80 sheets, a ribbon page marker, and an elastic closure to hold the waterproof cover closed.

COLOR	2-7/8" X 4-1/8"	4-1/8" X 5-7/8"	5-7/8" X 8-1/4"
Black ■	A11881-2052	A11881-2054	A11881-2055
Bright Pink ■	A11881-3062	A11881-3064	A11881-3065
Green ■	A11881-7021	A11881-7022	A11881-7023
Orange ■	A11881-4512	A11881-4514	A11881-4515
Purple ■	A11881-6002	A11881-6004	A11881-6005
Red ■	A11881-2982	A11881-2984	A11881-2985
Royal Blue ■	A11881-5062	A11881-5064	A11881-5065
Turquoise ■	A11881-5112	A11881-5114	A11881-5115
	EACH 12/EA	EACH 12/EA	EACH 12/EA
	\$5.25 \$4.73	\$8.80 \$7.95	\$10.15 \$9.13



Moleskine® Cahier Notebook Sets

Soft, flexible, and lightweight, Cahier Notebooks are ideal for jotting down thoughts and sketches. Sets contain three books, each featuring multiple blank pages of 70 gsm paper (16 perforated), heavy-duty cardboard covers, and spacious inside pockets.

Pocket Size — 64 pages, 3-1/2" x 5-1/2"

NUMBER	COLOR	EACH	6/EA
A11855-2001	Black	\$10.55	\$9.49
A11855-8331	Kraft	10.55	9.49
A11855-7322	Myrtle Green	10.55	9.49

Extra Large Size — 120 pages, 7-1/2" x 10"

NUMBER	COLOR	EACH	6/EA
A11855-2003	Black	\$21.15	\$19.03
A11855-8333	Kraft	21.15	19.03
A11855-7321	Myrtle Green	21.15	19.03

Denik Sketchbooks

Denik Sketchbooks feel as good in the hand as they do to draw upon. What feels just as good is that a portion of every purchase funds education projects around the world. Every sketchbook holds 44 sheets (88 pages) of 120 lb (180 gsm) mixed media paper made from 75% recycled content. The pages are hardbound into soft-touch vegan leather covers that are laminated to create a water-resistant barrier and preserve the cover's image. A ribbon bookmark holds your place between sketching sessions.

NUMBER	COLOR	SIZE	EACH	6/EA
A13868-1009	Blooming	9" x 7"	\$12.21	\$10.99
A13868-1007	Goal Digger	9" x 7"	12.21	10.99
A13868-1008	Ice Cream Swirl	9" x 7"	12.21	10.99
A13868-1005	Ideas & Such	9" x 7"	12.21	10.99
A13868-1006	Now or Never	9" x 7"	12.21	10.99
A13868-1004	Stay Humble	9" x 7"	12.21	10.99
A13868-1001	Chief Elephant	11" x 8-1/2"	17.76	15.98
A13868-1003	Crazy Ideas	11" x 8-1/2"	17.76	15.98
A13868-1002	Drawing Mountains	11" x 8-1/2"	17.76	15.98



Strathmore® Soft Cover Art Journals

Flexible and lightweight, these journals have a velvety cover in a rich, dark brown color. The durable Smyth-sewn binding allows pages to lie flatter for ease of drawing, sketching, and painting. Made in the USA. Sheet counts vary. For details, visit DickBlick.com.

400 Series Drawing Art Journals — 80 lb (130 gsm).

NUMBER	SIZE	EACH	6/EA
A67074-1105	8" x 5-1/2"	\$14.13	\$12.72
A67074-1107	9-3/4" x 7-3/4"	17.59	15.83

400 Series Toned Sketch Art Journals — 80 lb (118 gsm).

NUMBER	COLOR	SIZE	EACH	6/EA
A67077-2625	Toned Gray	8" x 5-1/2"	\$14.23	\$12.81
A67077-2627	Toned Gray	9-3/4" x 7-3/4"	17.78	15.99
A67077-8285	Toned Tan	8" x 5-1/2"	14.23	12.81
A67077-8287	Toned Tan	9-3/4" x 7-3/4"	17.78	15.99

500 Series Mixed Media Art Journals — 90 lb (190 gsm).

NUMBER	SIZE	EACH	6/EA
A13818-1005	8" x 5-1/2"	\$18.17	\$16.35
A13818-1007	9-3/4" x 7-3/4"	23.07	20.76

WARNING! Products marked with a Prop 65 symbol (■ or ▼) can expose you to chemicals, including cadmium, which are known to the State of California to cause cancer and birth defects or other reproductive harm. For more information, visit P65Warnings.ca.gov.



Stillman & Birn™ Archival Sketchbooks Zeta Series

Zeta Series Sketchbooks contain multiple sheets of heavyweight (180 lb, 270 gsm), natural white multimedia paper that can accept multiple wet media washes. Its smooth surface also assures exceptional line control for pen-and-ink and a full range of dry media.

Hardbound — 26 Sheets				
NUMBER	SIZE	ORIENTATION	EACH	12/EA
A13814-1055	8-1/2" x 5-1/2"	Portrait	\$26.81	\$24.13
A13814-1082	11-3/4" x 8-1/4"	Portrait	34.97	31.48
Soft Cover — 26 Sheets				
NUMBER	SIZE	ORIENTATION	EACH	12/EA
A13864-1005	3-1/2" x 5-1/2"	Landscape	\$11.39	\$10.36
A13864-1001	5-1/2" x 3-1/2"	Portrait	13.27	11.93
A13864-1006	5-1/2" x 8-1/2"	Landscape	18.65	16.78
A13864-1002	8-1/2" x 5-1/2"	Portrait	18.65	16.78
A13864-1003	8" x 10"	Portrait	28.28	25.45
A13864-1004	7-1/2" x 7-1/2"	Square	23.33	21.20
Wirebound — 26 Sheets				
NUMBER	SIZE	ORIENTATION	EACH	12/EA
A13814-1006	8" x 6"	Portrait	\$18.65	\$16.78
A13814-1007	10" x 7"	Portrait	23.31	20.98
A13814-1009	12" x 9"	Portrait	27.97	25.18



Stillman & Birn™ Beta Series Mixed Media Sketchbooks

Ideal for drawing, inking techniques, blending and layering with colored pencils and pastels, and advanced wet media techniques (including wet-into-wet painting, glazing, lifting, and masking), this robust paper can also be used for oil painting when prepared with gesso. The paper is both internally and surface-sized to provide exceptional wet strength for layering of wet media, lifting of pigment, and repeated erasing without damage. These wirebound sketchbooks contain 26 sheets (52 pages) of 180 lb (270 gsm), natural white paper with a cold press surface.

NUMBER	SIZE	EACH	12/EA
A11891-1205	5 1/2" x 3 1/2"	\$11.47	\$10.33
A11891-1105	5 1/2" x 8 1/2"	19.13	17.22
A11891-1208	8 1/2" x 5 1/2"	19.13	17.22
A11891-1102	8" x 10"	26.79	24.11

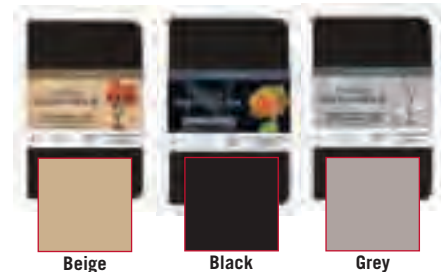

Stillman & Birn™ Nova Mixed Media Sketchbooks

These unique softcover sketchbooks hold 46 sheets of a luminescent toned paper that supports a wide range of dry and wet media. Every sheet holds ink lines without feathering and withstands multiple erasures without pilling. Ideal for colored pencils, inks, gel pens, paint markers, watercolors, gouache, chalk pastels, oil pastels, water-soluble graphite, charcoal, Conté crayons, colored dry pigments, and watercolor pencils. 93 lb (150 gsm).

NUMBER	COLOR	SIZE	EACH	12/EA
A13844-8145	Beige	5-1/2" x 8-1/2"	\$20.33	\$18.30
A13844-8142	Beige	8" x 10"	28.46	25.62
A13844-2025	Black	5-1/2" x 8-1/2"	20.33	18.30
A13844-2022	Black	8" x 10"	28.46	25.62
A13844-2905	Grey	5-1/2" x 8-1/2"	20.33	18.30
A13844-2902	Grey	8" x 10"	28.46	25.62

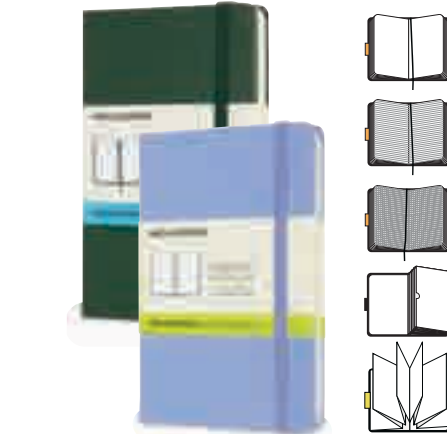

Moleskine™ Classic Hardbound Notebooks

Sketch, jot down notes, and more. Every Moleskine Classic Notebook has a rigid, durable oil cloth bound "moleskine" cover, sturdy thread-bound binding, acid-free paper pages, a built-in elastic closure, ribbon placeholder, and an expandable pocket.

Pocket Sized — 5-1/2" x 3-1/2", 192 Pages

NUMBER	DESCRIPTION	COLOR	EACH	4/EA
A11800-2055	Blank	Black	\$17.69	\$15.92
A12733-1340	Blank	Light Blue	15.60	14.04
A12733-1370	Blank	Light Green	15.60	14.04
A11800-7043	Blank	Metallic Green	15.60	14.04
A77851-5291	Blank	Sapphire Blue	17.69	15.92
A11800-7043	Dotted	Metallic Green	15.60	14.04
A12733-1570	Dotted	Sapphire Blue	15.60	14.04
A11800-2035	Gridded	Black	17.69	15.92
A12733-1010	Ruled	Black	17.69	15.92
A11800-7041	Ruled	Metallic Green	15.60	14.04
A11855-4102	Ruled	Red	17.69	15.92
A12733-1610	Ruled	Reef Blue	15.60	14.04
A12733-1540	Ruled	Sapphire Blue	15.60	14.04

Large — 8-1/4" x 5", 240 Pages

NUMBER	DESCRIPTION	COLOR	EACH	4/EA
A12733-1070	Blank	Black	\$20.98	\$18.88
A12733-1350	Blank	Light Blue	16.21	14.59
A12733-1380	Blank	Light Green	16.21	14.59
A11800-3010	Blank	Red	20.98	18.88
A12733-1640	Blank	Reef Blue	16.21	14.59
A77851-5292	Blank	Sapphire Blue	20.98	18.88
A11800-7061	Dotted	Metallic Green	16.21	14.59
A12733-1580	Dotted	Sapphire Blue	16.21	14.59
A11800-3085	Dotted	Scarlet Red	16.21	14.59
A12733-1050	Gridded	Black	20.98	18.88
A11800-2825	Ruled	Black	20.98	18.88
A77873-4010	Ruled	Red	20.98	18.88
A12733-1620	Ruled	Reef Blue	16.21	14.59
A77851-5290	Ruled	Sapphire Blue	20.98	18.88

X-Large — 9-3/4" x 7-1/2", 192 Pages

NUMBER	DESCRIPTION	COLOR	EACH	4/EA
A11800-2022	Blank	Black	\$27.40	\$24.66
A12733-1360	Blank	Light Blue	22.75	20.47
A12733-1390	Blank	Light Green	22.75	20.47
A11800-7052	Blank	Metallic Green	22.75	20.47
A12733-1110	Blank	Navy	27.40	24.66
A12733-1650	Blank	Reef Blue	22.75	20.47
A11800-7053	Dotted	Metallic Green	22.75	20.47
A12733-1590	Dotted	Sapphire Blue	22.75	20.47
A11800-2021	Ruled	Black	27.40	24.66
A11800-7051	Ruled	Metallic Green	22.75	20.47
A12733-1550	Ruled	Sapphire Blue	22.75	20.47
A11800-3084	Ruled	Scarlet Red	22.75	20.47



D-E Canson™ Artist Series Sketch Books

D Wirebound — Double wirebound on the long side, this hardcover sketchbook lies flat so you can use the whole page. It contains 80 pure white, 65 lb (96 gsm), acid-free sheets of paper.

NUMBER	SIZE	EACH	12/EA	24/EA
A10349-2000	5" x 7"	\$13.96	\$12.56	\$11.93
A10349-2006	6" x 6"	13.96	12.56	11.93
A10349-1021	7" x 10"	18.96	17.06	16.21
A10349-1023	9" x 12"	22.99	20.69	19.66
A10349-2005	11" x 14"	28.66	25.79	24.50

E Hardbound — This durable sketchbook features a black leather-like hardbound cover and 108 sheets of 65 lb (96 gsm) white, acid-free paper to sketch on.

NUMBER	SIZE	EACH	12/EA	24/EA
A10350-2000	4" x 6"	\$10.30	\$9.27	\$8.81
A10350-1085	5-1/2" x 8-1/2"	11.81	10.63	10.10
A10350-1011	8-1/2" x 11"	12.89	11.60	10.99
A10350-2001	11" x 14"	25.51	22.96	21.81



BLICK sketchbooks

F-G Blick™ Sketchbooks

Just the thing for those quick sketches and drawings, in the studio or in the field. Our economical yet high-quality sketchbooks contain 108 pages of acid-free, cream-colored 65 lb (98 gsm) paper with excellent tooth for all dry media techniques. The pages are bound in durable, heavyweight, black textured covers for long-term protection of your drawings and sketches.

F Hardbound — 110 pages.

NUMBER	SIZE	EACH	6/EA	12/EA
A11879-1055	5-1/2" x 8-1/2"	\$9.41	\$8.47	\$8.05
A11879-1085	8-1/2" x 11"	10.26	9.23	8.77

G Spiral-bound — 80 pages.

NUMBER	SIZE	EACH	6/EA	12/EA
A13815-1022	7" x 10"	\$14.34	\$12.90	\$12.25
A13815-1023	9" x 12"	17.11	15.40	14.63



Blackwing™ Slate Notebooks

The perfect companion for your Palomino Blackwing pencils, this notebook features 160 pages of high-quality, 100 gsm paper, a durable dual-sewn binding, a wear-resistant, matte, polyurethane cover (three color choices), a canvas spine, and a unique pencil holster preloaded with a Blackwing 602 pencil. Choose blank or ruled. Notebooks measure 8-1/4" x 5".

NUMBER	DESCRIPTION	EACH
A13858-1001	Black, Blank	\$27.45
A13858-1002	Black, Ruled	27.45
A13858-1005	Gray, Blank	27.45
A13858-1006	Gray, Ruled	27.45
A13858-1003	Pearl, Blank	27.45
A13858-1004	Pearl, Ruled	27.45

A Canson™ 180 Degree ArtBook™

Elegant and versatile, the 180 Degree ArtBook features a coptic-style binding that allows it to lie completely flat so you can use both pages at the same time. The hardbound books are filled with 80 sheets of 65 lb (96 gsm) French-made Crobart paper that is ideal for all dry media techniques. The books also feature rounded corners and a magnetic closure.

NUMBER	SIZE	EACH	6/EA
A11889-1035	3-1/2" x 5-1/2"	\$14.61	\$13.15
A11889-1055	5-1/2" x 8-1/2"	21.59	19.43
A11889-1083	8-1/4" x 11-3/4"	25.92	23.33

B Canson™ Artist Series Mix Media ArtBook™

Ideal for dry media, markers, pens, wet media techniques, and even collage, these hardbound pads contain 20 sheets of heavyweight, 138 lb (224 gsm) French paper that's perfect for final drawings. Micro-perforated for easy removal, the two-sided sheets feature a medium texture on one side and a fine texture on the other. Both offer excellent erasability.

NUMBER	SIZE	EACH	6/EA
A22737-1055	5-1/2" x 8-1/2"	\$13.24	\$11.92
A22737-1007	7" x 10"	20.43	18.39
A22737-1009	9" x 12"	25.03	22.53

C Bee Creative™ Mixed Media Books

This paper has a natural white color and excellent structure for mixed media. It features two distinct surfaces — cold press for dry media on one side, and a smoother hot press surface on the other side for pen-and-ink and mixed media. Books hold 50 sheets, double-wirebound into heavyweight covers. 93 lb (152 gsm).

NUMBER	SIZE	EACH	12/EA
A13833-1008	5-1/2" x 8"	\$16.09	\$14.50
A13833-1088	8" x 8"	19.35	17.40
A13833-1011	8-1/2" x 11"	21.55	19.40

Fabriano™ Hardcover Watercolor Journals

New from Fabriano, these beautiful hardcover watercolor journals are made in Italy and hold 30 sheets of acid-free, FSC certified paper. Internally and externally sized, the paper contains 25% cotton. A sewn binding allows the books to lie flat for capturing wide landscapes and panoramic views. 90 lb (200 gsm).

NUMBER	SIZE	EACH	6/EA
A09615-1006	6" x 9"	\$27.26	\$24.53
A09615-1023	9" x 12"	41.52	37.36

Pentalic™ Aqua Journals

The acid-free, European-made paper in Pentalic Aqua Journals is the perfect weight and texture for watercolor journaling. Six "signatures" are sewn into a beautiful landscape-format hardcover book so the pages lie flat when the book is open. An elastic brush holder is attached to the top of the book, perfect for holding a travel brush (not included). The Aqua Journal is fitted with Pentalic's signature ribbon marker, elastic band closure, and storage pocket. 48 pages. 140 lb (300 gsm). FSC-certified.

NUMBER	SIZE	EACH	10/EA
A10176-1005	5" x 8"	\$28.29	\$25.45
A10176-1007	7" x 10"	44.25	39.85
A10176-1085	8-1/2" x 11"	47.25	42.99

**A Blick® Studio Mixed Media Pads**

Ideal for sketches, quick studies, or for practicing techniques, this paper offers wet media performance on a dry media surface. The medium-weight, 80 lb (119 gsm) paper can be used with watercolors, acrylics, pen-and-ink, pencils, markers, and pastels. 60-sheet spiral-bound pads (18" x 24" pad holds 30 sheets).

NUMBER	SIZE	EACH	12/EA
A13649-1023	9" x 12"	\$9.39	\$8.45
A13649-1005	11" x 14"	11.83	10.65
A13649-1017	14" x 17"	17.55	15.79
A13649-1009	18" x 24"	18.36	16.52

B Canson® Artist Series Mix Media Pads

These pads are ideal for dry media, markers, pens, wet media techniques, and even collage. Each wirebound pad contains 20 sheets of heavyweight, 138 lb (224 gsm) French paper that is perfect for final drawings. Micro-perforated for easy removal, the two-sided sheets feature a medium texture on one side and a fine texture on the other, both offering excellent erasability.

NUMBER	SIZE	EACH	12/EA
A13653-1009	9" x 12"	\$8.64	\$7.78
A13653-1011	11" x 14"	12.46	11.21

C Pacon® UCreate® Mixed Media Paper

This heavyweight (80 lb), acid-free, sulphite art paper has a natural white color, a medium tooth, and extra sizing that makes it a great choice for all types of media. Available in convenient, economical packs, UCreate Mixed Media Paper is excellent for pencils, colored pencils, and charcoal, as well as pen-and-ink, markers, oil pastels, and most wet media.

NUMBER	DESCRIPTION	SHEETS	EACH	6/EA
A09701-1006	12" x 18"	500	\$68.81	\$61.93
A09701-1009	18" x 24"	500	131.99	118.80
A09701-1015	24" x 36"	250	142.35	128.12

D Winsor & Newton® Mixed Media Pads

Designed to withstand the most rigorous mixed media techniques, these durable 135 lb (250 gsm) sheets are wirebound into a sketchbook format. The sheets are micro-perforated. 30-sheet pads.

NUMBER	SIZE	EACH	6/EA
A13887-1007	7" x 10"	\$12.11	\$10.90
A13887-1023	9" x 12"	14.54	13.09
A13887-1005	11" x 14"	20.20	18.18

E Canson® XL Mix Media Paper

The heavy sizing makes this paper excellent for watercolors and acrylics, as well as dry media. This fine tooth paper also erases well and blends easily. 98 lb (160 gsm). 60-sheet pads (18" x 24" holds 30 sheets).

NUMBER	SIZE	EACH	6/EA
A12468-1022	7" x 10"	\$8.57	\$7.71
A12468-1023	9" x 12"	12.39	11.15
A12468-1005	11" x 14"	18.26	16.43
A12468-1017	14" x 17"	25.53	22.98
A12468-1009	18" x 24"	28.38	25.54

Rolls

NUMBER	SIZE	EACH	6/EA
A12468-1361	36" x 10 yd	\$29.92	\$26.93
A12468-1481	48" x 10 yd	34.52	31.07

F Strathmore® 300 Series Mixed Media Pads

For mixed media sketches, quick studies, and practicing of techniques, this medium-weight, 90 lb (190 gsm) paper is wirebound into a sketchbook format. The sheets are micro-perforated (except for the 5-1/2" x 8-1/2" size). 40-sheet pads.

NUMBER	SIZE	EACH	6/EA
A13639-1085	5-1/2" x 8-1/2"	\$8.28	\$7.45
A13639-1023	9" x 12"	14.30	12.87
A13639-1005	11 x 14	20.77	18.69

G Strathmore® 400 Series Mixed Media Pads and Roll

For studies or finished art, this heavyweight, 140 lb (300 gsm) paper features a vellum surface. The gluebound pads contain 15 sheets each, with flip-over covers.

NUMBER	SIZE	EACH	6/EA
A13640-1021	6" x 8"	\$4.35	\$3.91
A13640-1023	9" x 12"	9.35	8.41
A13640-1005	11" x 14"	13.12	11.81
A13640-1009	18" x 24"	27.64	24.88

Roll

NUMBER	SIZE	EACH	6/EA
A13640-1042	42" x 8 yd	\$48.15	\$43.33

H Strathmore® 500 Series Mixed Media Paper

This professional-quality paper offers true wet and dry performance. The surface is internally sized to accept wet media yet has a durable vellum finish for traditional drawing techniques. Made from 100% premium cotton fiber, this archival paper is acid-free and lignin-free. The sheets are ideal for bookmaking.

90 lb (190 gsm)

NUMBER	SIZE	EACH	10/EA
A10264-1001	22" x 30", Sheet	\$3.74	\$3.37
A10264-1002	22" x 30", 4-Pack	16.10	14.49
A10264-1042	42" x 8 yd, Roll	60.15	54.13

350 lb (570 gsm) — 12-Sheet Pads

NUMBER	SIZE	EACH	12/EA
A13855-1021	6" x 8"	\$10.48	\$9.43
A13855-1023	9" x 12"	20.52	18.47
A13855-1005	11" x 14"	28.49	25.64

I Bienfang® Mixed Media Pads

An excellent choice for watercolors, acrylics, pen-and-ink, pencils, markers, pastels, collage, and more. The fine-textured surface accepts wet media well, erases easily, and mixes well. 40-sheet spiral-bound pads. 90 lb (146 gsm).

NUMBER	SIZE	EACH	12/EA
A22784-1055	8-1/2" x 5-1/2"	\$4.28	\$3.85
A22784-1023	12" x 9"	6.55	5.90
A22784-1005	14" x 11"	9.21	8.29

**Grumbacher® Mixed Media Pads**

This 90 lb (185 gsm) heavyweight white drawing paper has a medium-tooth texture that's perfect for dry media and light wet media washes. Every pad is dual loop wirebound and features patent-pending "In & Out" pages that let you remove sheets from the pad for painting, reworking, scanning, and more, then return them to the pad for transporting and safekeeping. 50-sheet pads.

NUMBER	SIZE	EACH	6/EA
A13850-1001	5-1/2" x 8-1/2"	\$8.79	\$7.89
A13850-1002	7" x 10"	10.31	9.29
A13850-1003	9" x 12"	12.33	11.11
A13850-1004	11" x 14"	16.64	15.17

**Strathmore® 400 Series Black Mixed Media Pads**

Create bold effects on black paper with metallic inks and watercolors, gel pens, pastels, colored pencils, and more. The ultimate choice for mixed media work, Strathmore 400 Series Black Mixed Media paper is ideal for studies or finished art. Available in 15-sheet, gluebound pads with flip-over covers. 184 lb (300 gsm).

NUMBER	SIZE	EACH	12/EA
A13874-2021	6" x 8"	\$5.21	\$4.69
A13874-2023	9" x 12"	9.71	8.74
A13874-2025	11" x 14"	13.96	12.56
A13874-2029	18" x 24"	26.95	24.25

Strathmore® Toned Mixed Media Pads >

The perfect hybrid of two of Strathmore's most-loved papers — 400 Series Toned Sketch and 400 Series Mixed Media — this heavyweight mixed media paper is toned specifically for use with light and dark media. It also combines characteristics of a watercolor paper and the finish of a drawing sheet, for use with both wet and dry media. Proudly made in the USA, these acid-free papers are 100% recycled, and contain 30% post-consumer content. 15-sheet pads. 184 lb (300 gsm).

When ordering sheets of paper or board larger than 18" x 24", a handling fee may apply. See page 648.

Strathmore® Visual Journals

High-performance papers and heavy-duty covers help artists reflect, explore, and create! Designed for mixed media, Visual Journals feature a wire binding that is thicker and stronger, with a cover that lays flat.

Acid-free.
Drawing — 100 lb (163 gsm) medium tooth, 42 sheets.

NUMBER	SIZE	EACH	12/EA
A10256-0558	5-1/2" x 8"	\$8.93	\$8.04
A10256-1023	9" x 12"	14.37	12.93

Bristol Smooth — 100 lb (260 gsm), 28 sheets.

NUMBER	SIZE	EACH	12/EA
A13327-0558	5-1/2" x 8"	\$8.59	\$7.73
A13327-1023	9" x 12"	15.92	14.33

Bristol Vellum — 100 lb (260 gsm), 24 sheets.

NUMBER	SIZE	EACH	12/EA
A13327-1558	5-1/2" x 8"	\$8.59	\$7.73
A13327-2023	9" x 12"	15.92	14.33

Mixed Media — 90 lb (190 gsm) vellum, 34 sheets.

NUMBER	SIZE	EACH	12/EA
A10255-0558	5-1/2" x 8"	\$7.99	\$7.19
A10255-1023	9" x 12"	13.94	12.55

Watercolor — 90 lb (190 gsm), 34 sheets.

NUMBER	SIZE	EACH	12/EA
A10093-1023	9" x 12"	\$11.71	\$10.54
A10093-1558	5-1/2" x 8"	7.61	6.85
A10093-2023	9" x 12"	11.71	10.54

**Fabriano® Black Black and White Pads**

These stunning pads hold 20 sheets of deep black or bright white paper, tapebound for easy removal. Ideal for pastels, colored pencils, markers, and paper crafts, this heavier weight, 300 gsm paper also accepts light water media such as gouache and watercolors. The acid-free paper is made from chlorine-free cellulose pulp. Made in Italy.

NUMBER	COLOR	SIZE	EACH	3/EA
A10660-1008	Black	8" x 8"	\$10.58	\$9.53
A10660-1023	Black	9" x 12"	13.61	12.25
A10661-1008	White	8" x 8"	10.58	9.53

**Strathmore® Vision™ Mixed Media Pads**

Strathmore Vision Mixed Media Pads offer a medium-weight, all-purpose paper in a sketching format. A good choice for all dry media, this versatile 98 lb (168 gsm) paper can also be used for light wet media. Every pad holds 70 sheets of micro-perforated paper, spiral-bound into a sturdy chipboard backing. A tear-off top sheet reveals a customizable, 184 lb (300 gsm), steel blue cover. Made in the USA.

NUMBER	SIZE	EACH	6/EA
A13841-1010	7" x 10"	\$7.80	\$6.99
A13841-1023	9" x 12"	11.44	10.30
A13841-1005	11" x 14"	15.93	14.34

Strathmore® 400 Series Colored Pencil Pads

This paper's toothy, clean surface is great for any colored pencil technique. The heavy weight and vellum surface allow smooth, even application of multiple layers of color, and the durable surface also stands up to repeated erasing and reworking. This paper is also excellent for graphite pencils, charcoal, and sketching sticks. Wirebound pads hold 30 sheets of acid-free, white, 100 lb (163 gsm) paper. Sheets are true size when removed at the micro-perforation. Made in the USA.

NUMBER	SIZE	EACH	12/EA
A10488-1001	6" x 8"	\$4.60	\$4.14
A10488-1023	9" x 12"	9.69	8.72
A10488-1005	11" x 14"	12.92	11.63
A10488-1009	18" x 24"	25.73	23.16

NUMBER	COLOR	SIZE	EACH	12/EA
A10658-5011	Blue	6" x 8"	\$4.44	\$3.99
A10658-5013	Blue	9" x 12"	8.78	7.90
A10658-5015	Blue	11" x 14"	12.24	11.03
A10658-5019	Blue	18" x 24"	27.09	24.38
A10658-2501	Gray	6" x 8"	4.44	3.99
A10658-2503	Gray	9" x 12"	8.78	7.90
A10658-2505	Gray	11" x 14"	12.24	11.03
A10658-2509	Gray	18" x 24"	27.09	24.38
A10658-8231	Tan	6" x 8"	4.44	3.99
A10658-8233	Tan	9" x 12"	8.78	7.90
A10658-8235	Tan	11" x 14"	12.24	11.03
A10658-8239	Tan	18" x 24"	27.09	24.38





A Blick® Studio Drawing Pads

High-quality drawing pads at an economical Blick price! Pads hold heavyweight, 80 lb (130 gsm) white paper with a velvet-touch surface, ideal for pencil, charcoal, crayon, pen, and washes. Spiral-bound on the short side with a heavyweight backing board.

30-Sheet Pads

NUMBER	SIZE	EACH	12/EA	24/EA
A10314-1042	8" x 10"	\$4.58	\$4.12	
A10314-1043	9" x 12"	4.58	4.12	
A10314-1045	11" x 14"	5.24	4.72	
A10314-1047	12" x 18"	7.03	6.33	
A10314-1048	14" x 17"	7.55	6.79	
A10314-1049	18" x 24"	10.36	9.32	

70-Sheet Pads

NUMBER	SIZE	EACH	12/EA	24/EA
A10314-1052	8" x 10"	\$6.67	\$5.99	
A10314-1053	9" x 12"	6.84	6.16	
A10314-1055	11" x 14"	7.86	7.07	
A10314-1057	12" x 18"	12.63	11.37	
A10314-1059	18" x 24"	20.53	18.48	

B Strathmore® 200 Series Drawing Pads

Excellent for all dry media!

Professional results at a student price point. This heavyweight white drawing paper is designed for final artwork using pencil, pen-and-ink, charcoal, and markers. Tapebound pads contain 40 sheets of acid-free, 70 lb (104 gsm) paper.

NUMBER	SIZE	EACH	12/EA	24/EA
A10383-1055	5-1/2" x 8-1/2"	\$2.50	\$2.25	\$2.14
A10383-1003	9" x 12"	3.73	3.36	3.19
A10383-1005	11" x 14"	5.62	5.06	4.81

C Strathmore® 300 Series Drawing Paper

This bright white, acid-free paper is designed for the novice but invaluable for any artist who wants to experiment. It's receptive to pen-and-ink, pencil, crayon, charcoal, watercolor, and markers. 70 lb (104 gsm).

Pads — True size, micro-perforated sheets, spiral-bound on the short side.

NUMBER	SIZE	SHEET COUNT	EACH	12/EA	24/EA
A10312-1013	9" x 12"	50	\$6.34	\$5.71	\$5.42
A10312-1015	11" x 14"	50	8.86	7.97	7.57
A10312-1017	14" x 17"	50	12.48	11.23	10.67
A10312-1129	18" x 24"	25	12.48	11.23	10.67

Roll	NUMBER	SIZE	EACH	12/EA	24/EA
	A10312-1142	42" x 10 yd	\$15.97	\$14.37	\$12.93

D Strathmore® Heavyweight Drawing Pads

Designed to stand up to repeated erasing/reworking, this 100 lb (163 gsm) drawing paper has slightly more texture than Strathmore's 80 lb paper.

Excellent for pencils, colored pencils, charcoal, and sketching sticks, it's ideal for both initial sketches and finished work. Wirebound pads hold 24 acid-free, micro-perforated, true size sheets. Cream color. Made in the USA.

NUMBER	SIZE	EACH	12/EA	24/EA
A10296-1012	8" x 10"	\$6.87	\$6.18	\$5.87
A10296-1023	9" x 12"	7.56	6.80	6.46
A10296-1005	11" x 14"	10.45	9.40	8.93
A10296-1017	14" x 17"	15.51	13.96	13.26
A10296-1009	18" x 24"	23.20	20.88	19.84

E Strathmore® 400 Series Drawing Paper

Off-white drawing paper ideal for sketching and most finished work. Readily accepts pen-and-ink, pencil, crayon, charcoal, and markers. 24-Sheet Pad is micro-perforated for easy sheet removal. Uniform, regular surface. Acid-free.

80 lb (130 gsm) Sheets

NUMBER	SIZE	EACH	50/EA	100/EA
A10206-0006	12" x 19"	\$5.50	\$4.45	\$4.43
A10206-0009	19" x 24"	1.34	1.21	1.15

100 lb (260 gsm) Sheets

NUMBER	SIZE	EACH	50/EA	100/EA
A10206-1006	12" x 19"	\$6.69	\$6.62	\$6.59
A10206-1119	19" x 24"	1.65	1.48	1.41

10 yd Rolls — 100 lb (260 gsm).

NUMBER	SIZE	EACH	3/EA	6/EA
A10206-0036	36"	\$30.88	\$27.79	\$26.40
A10206-0042	42"	34.43	30.99	29.44

24-Sheet Pads — 80 lb (130 gsm). Spiral-bound on the short side.

NUMBER	SIZE	EACH	6/EA	12/EA
A10316-1003	9" x 12"	\$5.87	\$5.28	\$4.99
A10316-1005	11" x 14"	7.98	7.18	6.82
A10316-1007	12" x 18"	8.57	7.71	7.32
A10316-1017	14" x 17"	10.55	9.49	8.99
A10316-1009	18" x 24"	14.75	13.27	12.61

NEW! QUICK QUOTE.
Create a quote on demand at
DickBlick.com

F Strathmore® 400 Series Recycled Drawing Paper

Bright white, acid-free paper, ideal for use with pencil, crayon, pen-and-ink, charcoal, or light washes. Contains 30% post-consumer fiber. 80 lb (130 gsm).

NUMBER	SIZE	EACH	12/EA	24/EA
A10324-1013	9" x 12"	\$5.90	\$5.31	\$5.04
A10324-1015	11" x 14"	8.06	7.25	6.89
A10324-1017	14" x 17"	10.81	9.73	9.24
A10324-1009	18" x 24"	16.19	14.57	13.84

Roll

NUMBER	SIZE	EACH	12/EA	24/EA
A10324-1042	42" x 10 yd	\$17.33	\$15.60	\$14.82

G Strathmore® Artagain® Pads & Sheets

Pads of All Black — Black fiber-enhanced paper ideally suited for soft pastels, charcoal, or gel roller pens. 30% post-consumer fiber, acid-free, medium weight, recycled, and lightly textured. 24 sheets of 60 lb (160 gsm) paper.

NUMBER	SIZE	EACH	6/EA	12/EA
A10344-2001	6" x 9"	\$5.27	\$4.74	\$4.50
A10344-2003	9" x 12"	9.52	8.57	8.14

Pads of Assorted Colors — 24 sheets of assorted colors suitable for pastels and colored pencils. 60 lb (160 gsm).

NUMBER	SIZE	EACH	6/EA	12/EA
A10344-1003	9" x 12"	\$9.20	\$8.28	\$7.87
A10344-1006	12" x 18"	15.49	13.94	13.24

19" x 25" Sheets — 60 lb (160 gsm).

NUMBER	COLOR	EACH	25/EA	50/EA
A10344-2130	Coal Black	\$1.84	\$1.66	\$1.58
A10344-1050	Flannel White	1.84	1.66	1.58
A10344-2660	Steel Grey	1.84	1.66	1.58

H Canson® XL® Drawing Pads

Manufactured using environmentally friendly methods, pads contain multiple sheets of acid-free cold press paper made from 100% recycled cellulose that is alkaline-buffered and contains no optical brighteners. It resists scraping and erasing, making it ideal for pencil, charcoal, sanguine chalk, pens, and gouache. 70 lb (114 gsm).

Top Wirebound

NUMBER	SIZE	EACH	12/EA	24/EA
A12467-1023	9" x 12"	\$8.04	\$7.24	\$6.88
A12467-1005	11" x 14"	10.67	9.60	9.12
A12467-1009	18" x 24"	21.47	19.32	18.35

Side Wirebound

NUMBER	SIZE	EACH	12/EA	24/EA
A12467-1058	8-1/2" x 5-1/2"	\$5.50	\$4.95	\$4.70
A12467-1003	12" x 9"	8.04	7.24	6.88



I Canson® XL® Black Drawing Pads

Canson's world-famous Colorline paper is great for high-contrast artwork that lasts. Fade-resistant dye and high-grade pigments guarantee longevity for finished artworks in colored pencil, acrylic marker, opaque pen-and-ink, gouache, and pastel. The fine-tooth surface is also ideal for crafters who work with gel pens, metallic markers, and other media. Wirebound, micro-perforated 40-sheet pads. 92 lb (150 gsm).

NUMBER	SIZE	EACH	12/EA	24/EA
A10655-1007	7" x 10"	\$7.70	\$6.93	\$6.58
A10655-1023	9" x 12"	10.48	9.43	8.96

J Canson® Artist Series Drawing Books

This heavyweight sketch paper is a classic cream color with a nice tooth for graphite, colored pencils, and pen-and-ink. Very smudge-resistant, it also erases cleanly. The wirebound books hold 60 sheets of micro-perforated, true size paper, plus a removable half sheet bookmark with tips and techniques from some of the most noted artists of the day. 90 lb (147 gsm).

NUMBER	SIZE	EACH	12/EA	24/EA
A10499-1058	5-1/2" x 8-1/2"	\$7.99	\$7.19	\$6.83
A10499-1023	9" x 12"	13.33	11.99	11.39

K Canson® Classic™ Cream Drawing Paper

This heavy, acid-free premium drawing paper has a creamy color and a medium tooth, well-suited for charcoal, pastel, pencil, or pen. 90 lb (147 gsm).

Pads — 24 micro-perforated sheets, double wire-bound on the short side. Extra-heavy chipboard backing.

NUMBER	SIZE	EACH	12/EA	24/EA
A10323-1103	9" x 12"	\$6.03	\$5.43	\$5.16
A10323-1105	11" x 14"	8.08	7.27	6.91
A10323-1117	14" x 17"	10.60	9.54	9.06
A10323-1109	18" x 24"	16.35	14.71	13.97

Rolls

NUMBER	SIZE	EACH	12/EA	24/EA
A10323-1361	36" x 10 yd	\$26.19	\$23.57	\$22.39
A10323-1481	48" x 10 yd	30.73	27.66	26.28

When ordering sheets of paper or board larger than 18" x 24", a handling fee may apply. See page 648.

L Canson® Pure White Drawing Pads

Bright white pad features a 102 brightness level that provides superb color contrast. Its fine tooth surface is ideal for detailed drawing in pencil, colored pencil, and pen-and-ink. True-size sheets with micro-perforation allow use of the full area and sheets tear cleanly from the pad. Superb erasability. 24 sheets per pad. 80 lb (130 gsm).

NUMBER	SIZE	EACH	12/EA	24/EA
A12424-1023	9" x 12"	\$6.04	\$5.44	\$5.17
A12424-1005	11" x 14"	8.13	7.32	6.95
A12424-1009	18" x 24"	16.54	14.89	14.15

M Strathmore® Vision™ Drawing Pads

The medium-tooth paper in Vision Drawing Pads is ideal for dry media studies. It offers easy blending and shading, and a strong surface for clean erasures. Sheets are micro-perforated for easy removal. Every pad has sturdy chipboard backing and a tear-off top sheet that reveals a heavyweight, customizable, steel blue cover. Made in the USA. 64 lb (104 gsm).

65-Sheet Pads

NUMBER	SIZE	EACH	6/EA
A10656-1023	9" x 12"	\$6.77	\$6.09
A10656-1005	11" x 14"	9.26	8.33

35-Sheet Pad

NUMBER	SIZE	EACH	6/EA
A10656-1009	18" x 24"	\$15.64	\$14.08

N Stonehenge® Drawing Paper Pads

A flawless, white vellum surface makes this 100% cotton paper the ideal choice for colored pencil. It's also recommended for etching, screen printing, embossing, drawing, and painting with pastels, pencil, charcoal, acrylics, and watercolors. 15 sheets per pad (the 18" x 24" pad has 12). 90 lb (250 gsm).

NUMBER	SIZE	EACH	12/EA	24/EA
A10440-1000	5" x 7"	\$10.32	\$9.28	
A10440-1008	8" x 8"	14.57	13.12	
A10440-1023	9" x 12"	20.61	18.55	
A10440-1005	11" x 14"	27.44	24.71	
A10440-1009	18" x 24"	56.11	50.50	

O Pacon® UCreate® Drawing Pads

The UCreate Drawing Pad contains high-quality, heavyweight, white sulphite paper for illustrations and final drawings. Acid-free. 72 lb (117 gsm). 24-sheet pads.

NUMBER	SIZE	EACH	12/EA	24/EA
A12416-1023	9" x 12"	\$3.72	\$3.36	\$3.18
A12416-1006	12" x 18"	7.41	6.67	6.33

P Arches® Drawing Paper Pads

Made on a cylinder mould from 100% cotton, these papers work well with pencils, pastels, charcoal, inks, pens, gouache, and felt tip pens. Designed for optimum conservation over time, they are acid-free and contain no optical brightening agents. 16-sheet pads.

Cream — 123 lb (200 gsm).

NUMBER	SIZE	EACH	6/EA
A10666-1103	9" x 12"	\$19.32	\$17.39
A10666-1104	10" x 14"	26.38	23.74

Extra White — 110 lb (180 gsm).

NUMBER	SIZE	EACH	6/EA
A10666-1063	9" x 12"	\$19.32	\$17.39
A10666-1064	10" x 14"	26.38	23.74

Q Pentalic® Nature Sketch Books

These heavyweight 130 lb (211 gsm), 25% cotton sheets have a toothy, rough vellum surface, suitable for pencil, charcoal, ink, acrylics, pastels, oil pastels, watercolor pencils, watercolors (light washes), and tempera. Plastic spiral-bound pads have a heavy chipboard back and hold 50 sheets (18" x 24" has 20 sheets). A portion of every sale benefits the American Wildlife Foundation.

NUMBER	SIZE	EACH	12/EA	24/EA
A12456-1075	7" x 5"	\$9.49	\$8.55	\$8.15
A12456-1011	11" x 8-1/2"	14.75	13.28	12.60
A12456-1006	12" x 6"	19.41	17.47	16.59
A12456-				

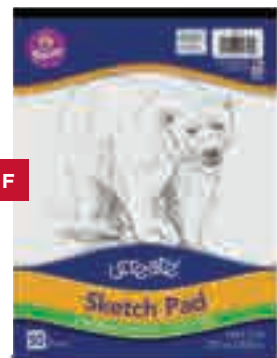

A Strathmore® 300 Series Sketch Pads

These economical pads hold 100 sheets of white, 50 lb (74 gsm), acid-free sketch paper with a medium surface. The micro-perforated sheets are actual size when removed at the perforation. Spiral-bound on the top.

NUMBER	SIZE	EACH	12/EA	24/EA
A10312-1002	5-1/2" x 8-1/2"	\$5.26	\$4.73	\$4.49
A10312-1003	9" x 12"	8.07	7.26	6.90
A10312-1005	11" x 14"	11.34	10.21	9.70
A10312-1007	14" x 17"	15.87	14.28	13.57

Class Pack of 200 Sheets

NUMBER	SIZE	EACH	12/EA	24/EA
A10312-2003	9" x 12"	\$16.53	\$14.88	\$14.14

B Strathmore® 400 Series Recycled Sketch Pads

100-Sheet Sketch Pads — A general-purpose 60 lb (89 gsm) sketch paper for classroom experimentation or perfecting techniques. Contains 30% post-consumer fiber. Acid-free, 100-sheet spiral-bound pads feature micro-perforated sheets that are actual size when removed at the perforation.

NUMBER	SIZE	EACH	12/EA	24/EA
A10324-1002	5-1/2" x 8-1/2"	\$5.54	\$4.99	\$4.74
A10324-1003	9" x 12"	9.19	8.27	7.86
A10324-1007	14" x 17"	17.89	16.10	15.29

50-Sheet Landscape Sketch Pads — Same paper as above, spiral-bound on the short side.

NUMBER	SIZE	EACH	12/EA	24/EA
A10324-1055	5-1/2" x 12"	\$6.96	\$6.26	\$5.95

30-Sheet Sketch Pads — Same paper as above, spiral-bound on the short side.

NUMBER	SIZE	EACH	12/EA	24/EA
A10324-1019	18" x 24"	\$16.21	\$14.59	\$13.86

C Strathmore® 400 Series Recycled Toned Sketch Pads & Rolls

Perfect for both light and dark media, Strathmore toned sketch paper is excellent for creating white highlights and dark shadows with graphite, chalk, charcoal, sketching sticks, markers, china markers, colored pencils, pens, and white gel pens. Made from 100% recycled, 30% post-consumer fiber. 80 lb (118 gsm).

50-Sheet Pads

NUMBER	COLOR	SIZE	EACH	12/EA
A13663-2585	Cool Gray	5-1/2" x 8-1/2"	\$6.28	\$5.65
A13663-8285	Warm Tan	5-1/2" x 8-1/2"	6.28	5.65
A13663-2512	Cool Gray	9" x 12"	8.87	7.98
A13663-8212	Warm Tan	9" x 12"	8.87	7.98

24-Sheet Pads

NUMBER	COLOR	SIZE	EACH	12/EA
A13663-2514	Cool Gray	11" x 14"	\$6.57	\$5.91
A13663-8214	Warm Tan	11" x 14"	6.57	5.91
A13663-2524	Cool Gray	18" x 24"	13.94	12.55
A13663-8224	Warm Tan	18" x 24"	13.94	12.55

Rolls

NUMBER	COLOR	SIZE	EACH	12/EA
A13663-2542	Cool Gray	42" x 10 yd	\$21.08	\$18.97
A13663-8242	Warm Tan	42" x 10 yd	21.08	18.97

D Strathmore® Vision Sketch Pads

Every Vision Sketch Pad has a tear-away flysheet that reveals a heavyweight cover made from high-quality, customizable, 184 lb (300 gsm) steel blue mixed media paper. Ideal for quick sketches, the lightly textured, fine tooth, 50 lb (74 gsm) paper is the perfect surface and weight for pencils, charcoal, sketching sticks, pastels, and other dry media. Made in the USA.

NUMBER	SIZE	SHEETS	EACH	6/EA
A10657-1008	5-1/2" x 8-1/2"	110	\$4.28	\$3.85
A10657-1023	9" x 12"	110	7.04	6.34
A10657-1005	11" x 14"	110	11.03	9.93
A10657-1009	18" x 24"	55	14.97	13.47

E Roaring Spring Kid's Sketch Book

Perfect for sketching, drawing, or even scribbling, this 50 lb white drawing paper works well with most media, including markers, crayons, pencils, and ink. The 40-sheet, 9" x 9" pad features snag-proof spiral binding and a durable 30 pt chipboard backing. Made in the USA.

NUMBER	EACH	12/EA
A13837-1001	\$3.85	\$3.46

F Pacon® UCreate® Sketch Pads

The white sulphite drawing paper in UCreate Sketch Pads is securely tapebound to a heavy chipboard back. Ideal for experimentation with various art techniques, the lightweight paper has a smooth surface. 50-sheet pads. 50 lb (74 gsm).

NUMBER	SIZE	EACH	12/EA
A12415-1023	9" x 12"	\$6.83	\$6.14
A12415-1006	18" x 12"	10.73	9.65

G Koala® Sketchbooks

These flexible saddle-stitched books are perfect for classrooms, field work, travel, and more. Available in four styles, each has a kraft paper cover, and light, teal-colored lines that can be lightened — and become invisible when scanned. Every book holds 30 double-sided pages — 60 usable pages in all! For product details, visit DickBlick.com.

NUMBER	DESCRIPTION	SIZE	EACH	12/EA
A13848-1085	Circular Grid	8-1/2" x 8-1/2"	\$5.29	\$4.76
A13848-1075	Dot Grid	7-3/4" x 9-3/4"	5.29	4.76
A13848-1095	3D Wide-Angle Isometric Grid	7-1/2" x 9-3/4"	5.29	4.76
A13848-1035	3D Perspective Grid	10-1/4" x 8"	5.29	4.76

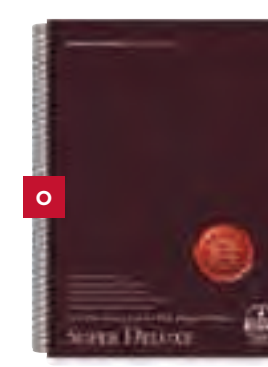
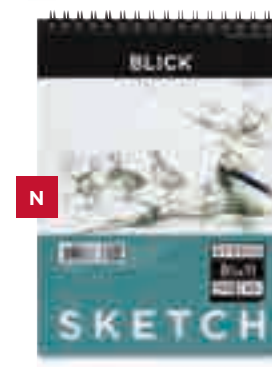
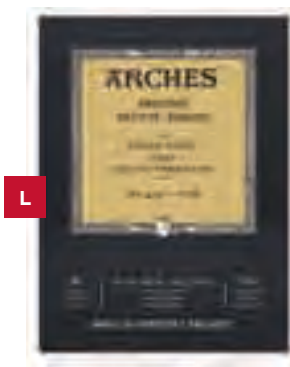

H Bee Paper® Co-Mo Sketch Pads

These pads contain 30 heavyweight, natural white, 80 lb (130 gsm) sheets that feature superb erasing qualities and a textured surface with excellent tooth, making them ideal for use with pencil and all dry media. The sheets are also double-sized to accept light use of wet media. They contain 20% recycled post-consumer fiber.

NUMBER	SIZE	EACH	6/EA	12/EA
A12496-1057	5" x 7"	\$4.09	\$3.68	\$3.50
A12496-1066	6" x 6"	4.30	3.87	3.68
A12496-1032	9" x 9"	6.14	5.53	5.25
A12496-1023	9" x 12"	7.25	6.53	6.20
A12496-1005	11" x 14"	9.49	8.55	8.13

I Canson® XL® Recycled Sketch Pads

Manufactured using environmentally friendly methods, these spiral-bound pads use 50 lb (74 gsm) XL paper, ideal for quick sketches with pencil, charcoal, pastel, or felt-tip pen. Acid-free, alkaline-buffered, 100% cellulose paper, with no optical brighteners.

100-Sheet Euro Fold

NUMBER	SIZE	EACH	12/EA	24/EA
A12470-1023	9" x 12"	\$7.30	\$6.57	\$6.24
A12470-1005	11" x 14"	11.10	9.99	9.49
A12470-1009	18" x 24"	33.58	30.22	28.71

50-Sheet Euro Fold

NUMBER	SIZE	EACH	12/EA	24/EA
A12470-1008	18" x 24"	\$15.32	\$13.79	\$13.10

100-Sheet Wirebound

NUMBER	SIZE	EACH	12/EA	24/EA
A12470-1024	9" x 12"	\$9.95	\$8.95	\$8.50

J Strathmore® 400 Series Sketch Pads

The general-purpose, heavyweight, acid-free sketch paper in these sketch pads is intended for classroom experimentation, practicing techniques, or quick studies with any dry media. A superior sheet with a harder surface, it's also a great choice for the more advanced artist. Micro-perforated sheets are true size when removed. 60 lb (89 gsm).

NUMBER	SIZE	EACH	12/EA
A12403-1009	18" x 24", 30 Sheets	\$16.25	\$14.62
A12403-1023	9" x 12", 50 Sheets	7.95	7.15
A12403-1005	11" x 14", 50 Sheets	9.86	8.87
A12403-1010	5" x 8", 100 Sheets	8.14	7.33
A12403-1123	9" x 12", 100 Sheets	12.83	11.55
A12403-1105	11" x 14", 100 Sheets	15.83	14.25
A12403-1017	14" x 17", 100 Sheets	23.19	20.87

K Canson® XL® Sketch Pads

Professional performance — at a value price! Canson XL Sketch Pads contain medium-tooth, micro-perforated white drawing paper, suitable for pencil, charcoal, and other dry media. Blends and erases well with a more opaque sheet. 50 lb (74 gsm).

NUMBER	DESCRIPTION	SIZE	EACH	12/EA
A12466-1005	Euro Fold	5-1/2" x 8-1/2", 100 Sheets	\$6.11	\$5.50
A12466-1003	Wirebound Side	9" x 12", 100 Sheets	7.88	7.09
A12466-1023	Wirebound Top	9" x 12", 100 Sheets	7.88	7.09
A12466-1009	Wirebound Top	18" x 24", 50 Sheets	23.20	20.88

L Arches® Sketch Pads

Ideal for experimenting and quick studies with pastels, charcoal, inks, and other dry media, this acid-free, 75% cotton paper is gelatin-sized on the surface and made on a traditional cylinder mould. Pads hold 20 sheets of 70 lb (105 gsm) paper.

NUMBER	SIZE	EACH	6/EA
A10665-1022	9" x 12"	\$18.40	\$16.56
A10665-1024	10" x 14"	25.09	22.58

M Canson® Universal™ Sketch Pads

A rough-surface paper well-suited to pencil, pen, charcoal, and light wash. Acid-free sheets are micro-perforated for a neat, clean edge. 100 sheets per pad. Spiral-bound on the long side with an extra-heavy chipboard back. 65 lb (96 gsm).

NUMBER	SIZE	EACH	12/EA	24/EA
A10322-1002	8-1/2" x 5-1/2"	\$7.12	\$6.41	\$6.09
A10322-1003	9" x 12"	8.99	8.09	7.69
A10322-1007	14" x 17"	25.24	22.72	21.58

35-Sheet Pad — Spiral-bound on the short side.

NUMBER	SIZE	EACH	12/EA	24/EA
A10322-1009	18" x 24"	\$18.61	\$16.75	\$15.90

N Blick® Studio Sketch Pads

Ideal for quick sketches or studies, or even for practice, these pads are an economical choice for beginning or experienced artists. The pads hold 100 sheets of acid-free white paper with a medium surface for pencils, crayons, charcoal, pen-and-ink, and all dry media. 60 lb (98 gsm). Made in the USA.

NUMBER	SIZE	EACH	12/EA
A13650-1055	5-1/2" x 8-1/2"	\$4.43	\$3.99
A13650-1085	8-1/2" x 11"	5.14	4.63
A13650-1023	9" x 12"	7.19	6.47
A13650-1005	11" x 14"	10.59	9.53
A13650-1017	14" x 17"	13.23	11.91

O Aquabee® Super Deluxe Sketchbooks, Rolls and Paper

[corrected gsm from 152 to 150 9/19/21 mw] This natural white, heavyweight, textured paper is double-sized to accept wet media but also renders beautiful results with charcoal, pencil, and more. Sketchbooks contain 60 sheets of pH-neutral, archival-quality paper, spiral-bound to a unique waterproof leatherette cover. 93 lb (150 gsm).

NUMBER	SIZE	EACH	6/EA
A10010-1011	4" x 6"	\$8.39	\$7.55
A10010-1066	6" x 6"	9.69	8.72
A10010-9001	6" x 9"	12.77	11.49
A10010-9003	9" x 12"	18.57	16.70
A10010-9005	11" x 14"	25.95	23.36
A10010-9007	14" x 17"	36.95	33.25

5-yd Roll

NUMBER	SIZE	EACH	6/EA
A10252-1036	36" wide	\$37.65	\$33.89

100-Sheet Pack

NUMBER	SIZE	EACH	6/EA
A10289-1023	9" x 12"	\$22.35	\$20.10
A10289-1009	18" x 24"	66.60	59.95

Did you know we have hundreds of lesson plans designed to meet the National Standards for Visual Arts Education? See them all at DickBlick.com/lesson-plans.

Blick® White Sulphite Drawing Papers

Compare Blick's drawing paper — its weight, texture, and value — with any other student drawing paper you've used. Our premium brand of student art papers has been produced to meet the needs of the art teacher, with a medium surface suitable for all pencil, charcoal, pastel, or pen-and-ink drawing. Available in three weights and a variety of packages.

50 lb (81 gsm) Weight — 500-sheet reams.

NUMBER	SIZE	EACH	12/EA
A10209-1013	9" x 12"	\$12.59	\$11.32
A10209-1015	12" x 18"	24.69	22.20
A10209-1019	18" x 24"	55.98	50.34
A10209-1015	24" x 36"	103.99	93.53

60 lb (98 gsm) Weight — 500-sheet reams.

NUMBER	SIZE	EACH	12/EA
A10209-1023	9" x 12"	\$16.09	\$14.49
A10209-1076	12" x 18"	33.30	29.99
A10209-1029	18" x 24"	69.48	62.55
A10209-1025	24" x 36"	159.76	143.83

60 lb (98 gsm) Weight — 100-sheet packages.

NUMBER	SIZE	EACH	12/EA
A10209-1003	9" x 12"	\$3.72	\$3.35
A10209-1007	12" x 18"	7.10	6.39
A10209-1009	18" x 24"	17.24	15.52
A10209-1005	24" x 36"	35.98	32.38

80 lb (124 gsm) Weight — 500-sheet reams.

NUMBER	SIZE	EACH	12/EA
A10209-1033	9" x 12"	\$17.71	\$15.95
A10209-1078	12" x 18"	35.85	32.28
A10209-1039	18" x 24"	74.19	66.80

80 lb (124 gsm) Weight — 100-sheet packages.

NUMBER	SIZE	EACH	12/EA
A10209-1043	9" x 12"	\$4.35	\$3.91
A10209-1079	12" x 18"	8.68	7.82
A10209-1049	18" x 24"	18.93	17.04
A10209-1045	24" x 36"	45.38	40.84

Pacon® Bright White Sulphite Drawing Paper

This multi-purpose, bright white, 100% sulphite sheet has excellent tooth and surface sizing, ideal for artists at all levels, from beginning to advanced. Available in three weights.

NUMBER	DESCRIPTION	SIZE	EACH	6/EA
A10266-1025	Medium Weight	24" x 36", 250-Sheet Pack	\$105.97	\$95.37
A10266-1315	Heavy Weight	24" x 36", 250-Sheet Pack	124.42	111.97

Light Weight — 500-Sheet Reams.

NUMBER	SIZE	EACH	6/EA
A10266-1123	9" x 12"	\$14.84	\$13.36
A10266-1106	12" x 18"	27.77	24.99
A10266-1109	18" x 24"	81.17	73.06

Medium Weight — 500-Sheet Reams.

NUMBER	SIZE	EACH	6/EA
A10266-1223	9" x 12"	\$20.82	\$18.74
A10266-1206	12" x 18"	41.40	37.15
A10266-1209	18" x 24"	90.58	81.29

Heavy Weight — 500-Sheet Reams.

NUMBER	SIZE	EACH	6/EA
A10266-1323	9" x 12"	\$19.77	\$17.80
A10266-1306	12" x 18"	38.76	34.90
A10266-1309	18" x 24"	71.33	64.23

Pacon Sulphite Drawing Paper — Supreme weight, white, 100% sulphite sheets. Medium tooth.

NUMBER	DESCRIPTION	SIZE	EACH	6/EA
A10228-1023	500-Sheet Ream	9" x 12"	\$25.82	\$23.24
A10228-1006	500-Sheet Ream	12" x 18"	51.10	45.99
A10228-1009	500-Sheet Ream	18" x 24"	97.24	87.52
A10228-2015	250-Sheet Pack	24" x 36"	132.11	118.90

Blick® All-Media Paper

This bright white paper is smooth enough for pen-and-ink but has enough tooth for pencil and pastel. 80 lb (82 gsm).

Sheets — Minimum Order: 100 sheets.

NUMBER	SIZE	EACH	100/EA	500/EA
A10210-1008	15" x 22"	\$4.43	\$3.38	\$3.35
A10210-1003	22" x 30"	.98	.86	.79

Blick® Economy Buff Manila Drawing Paper

All-purpose standard drawing paper. 50 lb (82 gsm) weight, 500-sheet reams.

NUMBER	SIZE	EACH	6/EA	12/EA
A10203-1103	9" x 12"	\$10.17	\$9.43	\$8.74
A10203-1107	12" x 18"	19.23	17.22	15.37
A10203-1109	18" x 24"	38.99	34.91	35.38

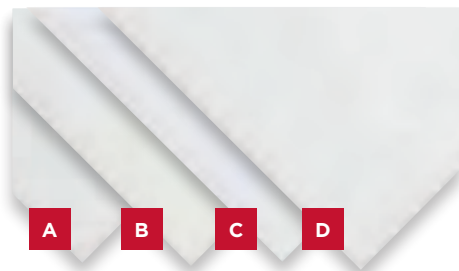

A-D Canson® Single Sheet Drawing Papers

Now your favorite Canson drawing papers are available in large single sheets! Choose from 70 lb (115 gsm) White Student Drawing, 90 lb (147 gsm) Classic Cream, 123 lb (200 gsm) Dessin White, or 111 lb (180 gsm) C'Agriain. Suitable for most dry media as well as pen-and-ink.

18" x 24"

NUMBER	DESCRIPTION	EACH	10/EA
A10240-1009	A Student Drawing, White	\$8.87	\$7.78
A10240-1109	B Classic Drawing, Cream	1.92	1.73

19-1/2" x 25-1/2"

NUMBER	DESCRIPTION	EACH	10/EA
A10240-1019	C Dessin, White	\$2.43	\$2.19
A10239-1002	D C'Agriain, White	1.99	1.79

Strathmore® 300 Series Newsprint Paper

An economical paper for practicing sketching or for creating preliminary drawings. 32 lb (52 gsm).

50-sheet Pads

NUMBER	SIZE	EACH	12/EA
A12402-1023	9" x 12", Rough	\$3.82	\$3.44
A12402-1017	14" x 17", Rough	7.38	6.64
A12402-1549	18" x 24", Rough	20.43	18.39
A12402-1559	18" x 24", Smooth	14.09	12.68

Roll

NUMBER	SIZE	EACH	12/EA
A12402-1036	36" x 24 yd	\$12.28	\$11.05

Blick® All-Purpose Newsprint

A school favorite for drawing with pencil, charcoal, pastels, crayons, and markers. 30 lb (49 gsm) standard weight with a strong, smooth surface and natural color. Heavy cardboard backing. Great Blick value!

50-Sheet Pads — Tapebound on the short side.

NUMBER	SIZE	EACH	6/EA	12/EA
A10311-1043	9" x 12"	\$3.03	\$2.73	\$2.59
A10311-1046	12" x 18"	4.52	4.07	3.87
A10311-1049	18" x 24"	9.17	8.25	7.84
A10311-1042	24" x 36"	16.94	15.25	14.49

100-Sheet Pads — Tapebound on the short side.

NUMBER	SIZE	EACH	6/EA	12/EA
A10311-1053	9" x 12"	\$3.94	\$3.55	\$3.37
A10311-1056	12" x 18"	6.49	5.84	5.55
A10311-1059	18" x 24"	11.42	10.28	9.77

500-Sheet Reams

NUMBER	SIZE	EACH	6/EA	12/EA
A10204-1085	8-1/2" x 11"	\$5.06	\$4.51	\$4.28
A10204-1003	9" x 12"	5.87	5.22	4.97
A10204-1007	12" x 18"	11.58	10.31	9.80
A10204-1009	18" x 24"	23.09	20.56	19.54
A10204-1005	24" x 36"	48.99	43.64	41.47



Canson® XL® Newsprint Pads

Rough surface, chlorine-free paper made from 100% post-consumer waste. For sketching with pencil, pastel, or charcoal. 30 lb (49 gsm). 100-sheet tapebound pads.

NUMBER	SIZE	EACH	12/EA	24/EA
A10309-1123	9" x 12"	\$4.93	\$4.44	\$4.22
A10309-1117	14" x 17"	9.65	8.68	8.25
A10309-1109	18" x 24"	15.17	13.65	12.97
A10309-1115	24" x 36"	28.16	25.34	24.07



Strathmore® 200 Series Newsprint Pads

This natural-toned, rough surface newsprint accepts pencil, pastel, charcoal, or markers, and is a great choice for beginning and practice sketches. 100-sheet pads. 30 lb (49 gsm).

NUMBER	SIZE	EACH	12/EA	24/EA
A10384-1009		\$12.69	\$11.42	\$10.85

Richeson® Bulk Drawing Paper Packs

An economical way to buy and use paper in the classroom! Packs contain multiple sheets of acid-free paper with a bright white surface, ideal for experimenting with pencils, charcoal, and pastels.

60 lb

NUMBER	DESCRIPTION	SIZE	EACH	12/EA
A14002-1105	800 Sheets	11" x 14"	\$68.30	\$61.48
A14002-1106	800 Sheets	12" x 18"	88.50	79.66
A14002-1109	700 Sheets	18" x 24"	142.78	128.51

75 lb

NUMBER	DESCRIPTION	SIZE	EACH	12/EA
A14002-1223	1000 Sheets	9" x 12"	\$56.80	\$51.13
A14002-1205	575 Sheets	11" x 14"	51.56	46.42
A14002-1206	575 Sheets	12" x 18"	66.81	60.14
A14002-1209	500 Sheets	18" x 24"	107.79	97.03

90 lb

NUMBER	DESCRIPTION	SIZE	EACH	12/EA
A14002-1023	800 Sheets	9" x 12"	\$64.78	\$58.30
A14002-1005	475 Sheets	11" x 14"	58.81	52.92
A14002-1006	475 Sheets	12" x 18"	76.20	68.58
A14002-1009	400 Sheets	18" x 24"	122.93	110.63

100 lb

NUMBER	DESCRIPTION	SIZE	EACH	12/EA
A14020-1003	700 Sheets	9" x 12"	\$59.36	\$53.42
A14020-1005	400 Sheets	11" x 14"	53.88	48.48
A14020-1006	400 Sheets	12" x 18"	69.31	62.38
A14020-1009	350 Sheets	18" x 24"	112.99	101.71

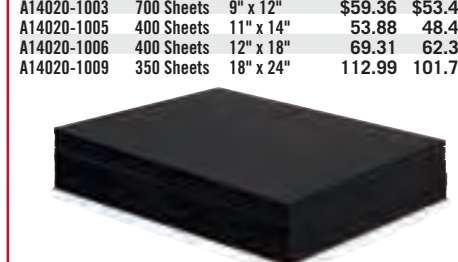

Richeson® Black Art Paper Bulk Packs

Kids will love drawing and writing on this very black art paper — and you'll love the savings! Great for gel and glitter pens, metallic paints and pens, pastels, chalk markers, and other media. The 135 lb paper has a toothy surface on both sides.

NUMBER	DESCRIPTION	SIZE	EACH	12/EA
A14006-1101	50 Sheets	6" x 9"	\$9.90	\$8.91
A14006-1106	50 Sheets	12" x 18"	38.12	34.31
A14006-1009	200 Sheets	18" x 24"	324.00	292.08
A14006-1005	250 Sheets	11" x 14"	105.94	95.36
A14006-1006	250 Sheets	12" x 18"	201.23	181.15
A14006-1023	425 Sheets	9" x 12"	172.48	155.27
A14006-1201	850 Sheets	6" x 9"	172.48	155.27



Richeson® Bulk Newsprint Paper

A long-time school favorite, newsprint is a great surface for pencils, pastels, charcoal, and markers. Richeson Bulk Newsprint offers an economical way to help kids draw, experiment, and learn without breaking your school budget. This 35 lb paper has a rough surface and is available in a variety of sizes and sheet counts.

NUMBER	DESCRIPTION	SIZE	EACH	12/EA
A14021-1003	1600 Sheets	9" x 12"	\$30.95	\$27.85
A14021-1005	900 Sheets	11" x 14"	35.67	32.10
A14021-1006	900 Sheets	12" x 18"	47.83	43.04
A14021-1009	1000 Sheets	18" x 24"	72.96	65.66

When ordering sheets of paper or board larger than 18" x 24", a handling fee may apply. See page 648.



Pacon® Dual Ruled Composition Books

Engage both hemispheres of the brain! Use the 3/8" ruled pages for class notes or journaling, and the 1/4" grid on the facing page for graphs, illustrations, and sketches. Colored paper also helps students who are dyslexic. Pages are permanently bound into a hard cover. Paper color matches the cover, in a lighter shade. Books measure 9-3/4" x 7-1/2". 100 sheets (200 usable pages).

NUMBER	COLOR	EACH	12/EA
A10659-5015	Blue	\$4.05	\$3.64
A10659-7015	Green	4.05	3.64
A10659-1025	White	4.05	3.64
A10659-4015	Yellow	4.05	3.64



Roaring Spring Composition Notebooks

These 100-page composition notebooks with a classic marbled pattern on the cover are great for recording notes — or choose unruled pages for sketching. The smooth, 15 lb writing paper works well for both. Pages are center-sewn and tapebound into a hard board cover. The insides of the covers are printed with a blank class schedule and other useful information. Pages are not intended to be removed. 9-3/4" x 7-1/2". Made in the USA.

NUMBER	DESCRIPTION	COLOR	EACH	12/EA
A10650-1001	Unruled	Blue	\$2.97	\$2.67
A10650				

**A Blick® Studio Bristol Pads**

Blick Studio Bristol is great for use with a wide variety of media. Choose the vellum surface for colored pencils, oil pastels, or charcoal, and the smooth surface for markers and pen-and-ink. Tapebound pads hold 15 acid-free, 100 lb (270 gsm) sheets. Made in the USA.

Vellum				
NUMBER	SIZE	EACH	12/EA	24/EA
A13329-1023	9" x 12"	\$5.06	\$4.55	\$4.32
A13329-1005	11" x 14"	6.74	6.07	5.77
A13329-1017	14" x 17"	10.98	9.88	9.39
A13329-1019	19" x 24"	16.32	14.69	13.96
Smooth				
NUMBER	SIZE	EACH	12/EA	24/EA
A13329-2023	9" x 12"	\$5.06	\$4.55	\$4.32
A13329-2005	11" x 14"	6.74	6.07	5.77
A13329-2017	14" x 17"	10.98	9.88	9.39
A13329-2019	19" x 24"	16.32	14.69	13.96

B Strathmore® 300 Series Bristol Board

The vellum surface is ideal for a broad range of media including crayon and charcoal. The smooth surface is suitable for pen or pencil. Acid-free. 100 lb (270 gsm).

Tapebound Pads — Vellum surface, 20 sheets.

NUMBER	SIZE	EACH	12/EA	24/EA
A13307-1003	9" x 12"	\$8.36	\$7.52	\$7.14
A13307-1005	11" x 14"	10.32	9.29	8.83
A13307-1007	14" x 17"	14.61	13.15	12.49
A13307-1001	19" x 24"	30.84	27.76	26.37

Tapebound Pads — Smooth surface, 20 sheets.

NUMBER	SIZE	EACH	12/EA	24/EA
A13307-1013	9" x 12"	\$8.36	\$7.52	\$7.14
A13307-1015	11" x 14"	10.32	9.29	8.83
A13307-1017	14" x 17"	14.61	13.15	12.49
A13307-1011	19" x 24"	30.84	27.76	26.37

Sheets — 22-1/2" x 28-1/2".

NUMBER	SURFACE	EACH	25/EA	50/EA
A13316-1052	Vellum	\$2.19	\$1.97	\$1.87
A13316-1042	Smooth	2.19	1.97	1.87

Rolls — 42" x 10 yd.

NUMBER	SURFACE	EACH	12/EA	24/EA
A13307-1042	Smooth	\$44.85	\$40.36	\$38.34
A13307-2042	Vellum	44.85	40.36	38.34

E Strathmore® 500 Series Bristol Board**15-Sheet Pads**

2-ply Vellum

NUMBER	SIZE	EACH	6/EA	12/EA
A13313-1015	11" x 14"	\$21.55	\$19.39	\$18.42
A13313-1017	14" x 17"	30.46	27.41	26.04

2-ply Plate

NUMBER	SIZE	EACH	6/EA	12/EA
A13313-1005	11" x 14"	\$24.37	\$21.93	\$20.83
A13313-1007	14" x 17"	40.55	36.49	34.67

**Canson® XL® Bristol Pads**

Canson XL Bristol Pads are available in smooth and vellum, ideal for both wet and dry media. The paper's bright white surface provides great contrast for ink, light washes, graphite, colored pencils, markers, and pastels. Each foldover pad holds 25 sheets — more paper for the money! 100 lb (260 gsm).

Smooth

NUMBER	SIZE	EACH	12/EA	24/EA
A13337-1023	9" x 12"	\$7.98	\$7.18	\$6.82
A13337-1025	11" x 14"	10.92	9.83	9.34
A13337-1011	11" x 17"	12.80	11.52	10.94
A13337-1017	14" x 17"	16.25	14.62	13.89

Vellum

NUMBER	SIZE	EACH	12/EA	24/EA
A13337-1123	9" x 12"	\$7.98	\$7.18	\$6.82
A13337-1105	11" x 14"	10.92	9.83	9.34
A13337-1111	11" x 17"	12.80	11.52	10.94
A13337-1117	14" x 17"	16.25	14.62	13.89

Side Wire Pads

NUMBER	SIZE	EACH	12/EA	24/EA
A13337-1007	7" x 10", Smooth	\$7.98	\$7.18	\$6.82
A13337-1107	7" x 10", Vellum	7.98	7.18	6.82

C-D Strathmore® 400 Series Bristol Board

When the longevity of cotton fibers is not required, both intermediate and professional artists recommend the 400 Series Bristol. The Vellum surface works well with pencil, charcoal, and pastel. The Smooth surface is ideal for detailed ink work and is also suited for pencil and marker. Both surfaces are acid-free and excellent for airbrush.

C Sheets — 22" x 30" sheets.

NUMBER	DESCRIPTION	STYLE	EACH	50/EA	100/EA
A13301-1032	Vellum	2-ply	\$3.85	\$3.46	\$3.29
A13301-1042	Vellum	3-ply	5.99	5.39	5.12
A13301-1052	Vellum	4-ply	8.07	7.26	6.90
A13301-1002	Smooth	2-ply	3.85	3.46	3.29
A13301-1012	Smooth	3-ply	5.99	5.39	5.12
A13301-1022	Smooth	4-ply	8.07	7.26	6.90

D Pads — 2-ply pads contain 15 sheets.

NUMBER	DESCRIPTION	SIZE	EACH	12/EA	24/EA
A13312-1003	Vellum	9" x 12"	\$9.27	\$8.34	\$7.92
A13312-1005	Vellum	11" x 14"	12.07	10.86	10.32
A13312-1007	Vellum	14" x 17"	19.28	17.35	16.48
A13312-1008	Vellum	18" x 24"	34.98	31.48	29.91
A13312-1013	Smooth	9" x 12"	9.27	8.34	7.92
A13312-1015	Smooth	11" x 14"	12.07	10.86	10.32
A13312-1017	Smooth	14" x 17"	19.28	17.35	16.48
A13312-1018	Smooth	18" x 24"	34.98	31.48	29.91

F Bienfang® Bristol Board Pads

A convenient, economical way to buy Bristol

Board — in 20-board pads.

Plate Surface (Smooth) — Acid-free; contains 50% recycled fiber. 146 lb (210 gsm), excellent for all wet media, pen-and-ink, airbrush, and mechanical drawing.

NUMBER	SIZE	EACH	6/EA	12/EA
A13302-1013	9" x 12"	\$6.77	\$6.10	\$5.80
A13302-1015	11" x 14"	10.11	9.10	8.65
A13302-1017	14" x 17"	14.90	13.71	12.99

Kid Surface (Vellum) — Excellent for use with pencil and airbrush. 146 lb (210 gsm).

NUMBER	SIZE	EACH	6/EA	12/EA
A13302-1003	9" x 12"	\$6.85	\$6.16	\$5.86
A13302-1005	11" x 14"	9.75	8.78	8.34
A13302-1007	14" x 17"	16.03	14.42	13.70

Koh-I-Noor® Bristol Pads

These pads hold 20 sheets of bright white, 100 lb (270 gsm), high-contrast bristol that accepts a variety of media. Choose either a smooth or vellum finish in a range of pad sizes. Every pad features dual loop, wirebound construction with Koh-I-Noor's unique In & Out pages and Domelock technology — making it easy to remove sheets for drawing, reworking, scanning, and more.

Smooth

NUMBER	SIZE	EACH	6/EA	12/EA
A13339-1008	5-1/2" x 8-1/2"	\$9.70	\$8.73	\$8.29
A13339-1023	9" x 12"	11.10	9.99	9.49
A13339-1017	11" x 17"	18.56	16.70	15.86
A13339-1024	19" x 24"	30.97	27.87	26.48

Vellum

NUMBER	SIZE	EACH	6/EA	12/EA
A13339-1108	5-1/2" x 8-1/2"	\$9.70	\$8.73	\$8.29
A13339-1123	9" x 12"	11.10	9.99	9.49
A13339-1117	11" x 17"	18.56	16.70	15.86
A13339-1124	19" x 24"	30.97	27.87	26.48

CRESCENT® illustration boards**Crescent® Hot Press**

Very smooth surfaces primarily for pen-and-ink, mounting, transfer lettering, and graphic design. Suitable for keylines, acrylic washes, airbrush, and adhesive film. Excellent quality.

Crescent No. 201 Hot Press — Medium weight. 16-ply (0.055" thick).

NUMBER	SIZE	EACH	25/EA	50/EA
A13409-1008	15" x 20"	\$3.90	\$3.51	\$3.33
A13409-1003	20" x 30"	7.32	6.59	6.26
A13409-1006	30" x 40"	13.57	12.21	11.60

Crescent No. 200 Hot Press — Extra heavy weight. 24-ply (0.090" thick).

NUMBER	SIZE	EACH	5/EA	15/EA
A13412-1008	15" x 20"	\$4.97	\$4.47	\$4.25
A13412-1003	20" x 30"	9.53	8.58	8.15
A13412-1006	30" x 40"	18.06	16.25	15.44

Crescent No. 20 University Grade Hot Press — 14-ply (0.050" thick). Bright White.

NUMBER	SIZE	EACH	10/EA	50/EA
A13410-1008	15" x 20"	\$2.54	\$2.29	\$2.18
A13410-1003	20" x 30"	4.51	4.06	3.86
A13410-1006	30" x 40"	9.07	8.16	7.75

Crescent No. 215 Hot Press — Professional-grade, bright white, smooth hot press surface for greater contrast with pen-and-ink and more transparent washes. 18-ply (0.060" thick).

NUMBER	SIZE	EACH	25/EA	50/EA
A13411-1008	15" x 20"	\$3.38	\$3.04	\$2.89
A13411-1003	20" x 30"	6.35	5.71	5.42
A13411-1006	30" x 40"	11.86	10.67	10.14

Crescent® Mixed Media

The ideal substrate for mixed media, markers, collage, or painting, with a smoother surface, a whiter core, and professional-quality backing papers. For additional colors, visit DickBlick.com.

NUMBER	COLOR	SIZE	EACH	15/EA	30/EA
A13442-1093	Chalk	20" x 30"	\$5.16	\$4.64	\$4.41
A13442-1183	Snow	20" x 30"	5.16	4.64	4.41

**Art Alternatives™ Art Boards**

Whether inking, ruling, airbrushing, or matting, these hand-sorted, individually inspected art boards offer the highest quality. Single thickness is approximately 14-ply; double thickness is approximately 24-ply.

Art Alternatives Hot Press Illustration Board — Bright white and extra smooth, with a premium surface designed for optimum performance. Erase it, scrape it, and re-ink. The surface paper is acid-free and performs well with all media, including airbrushing. Single thickness.

NUMBER	SIZE	EACH	15/EA	30/EA
A13447-1021	15" x 20"	\$3.93	\$3.53	\$3.36
A13447-1023	20" x 30"	7.43	6.70	6.36
A13447-1026	30" x 40"	13.64	12.26	11.65

Art Alternatives Cold Press Illustration Board — The medium tooth rag surface allows for exceptional color intensity and fidelity. Accepts a wide range of wet and dry media — watercolor, pastels, markers, charcoal, ink, and colored pencils.

NUMBER	SIZE	EACH	15/EA	30/EA
A13447-1011	15" x 20" Single	\$3.93	\$3.53	\$3.36
A13447-1013	20" x 30" Single	7.43	6.70	6.36
A13447-1016	30" x 40" Single	13.64	12.26	11.65
A13447-1036	30" x 40" Double	22.24	19.99	19.03

When ordering sheets of paper or board larger than 18" x 24", a handling fee may apply. See page 648.

Crescent® Cold Press

Slightly textured surface used primarily for illustration in watercolor, gouache, acrylic, tempera, pen-and-ink, charcoal, and pencil drawing. All Crescent boards strip easily for laser scanning.

Crescent No. 99 University Grade Cold Press — Economically priced with a medium-texture surface. 14-ply (0.050") thick.

NUMBER	SIZE	EACH	25/EA	50/EA
A13406-1008	15" x 20"	\$2.61	\$2.45	\$2.26
A13406-1003	20" x 30"	4.69	4.36	3.99
A13406-1006	30" x 40"	8.30	7.71	7.10

Crescent No. 100 Cold Press — Professional grade, heavyweight, with a medium surface. 24-ply (0.090" thick).

NUMBER	SIZE	EACH	10/EA	50/EA
A13407-1008	15" x 20"	\$3.74	\$3.37	\$3.20
A13407-1003	20" x 30"	7.17	6.45	6.13
A13407-1006	30" x 40"	13.59	12.23	11.62

Crescent No. 110 Cold Press — Heavyweight, professional-grade board with a medium texture. 100% rag, acid-free. 24-ply (0.09") thick.

NUMBER	SIZE	EACH	25/EA	50/EA
A13406-1028	15" x 20"	\$4.60	\$4.14	\$3.93
A13406-1203	20" x 30"	10.29	9.26	8.80
A13406-1206	30" x 40"	20.86	18.77</	

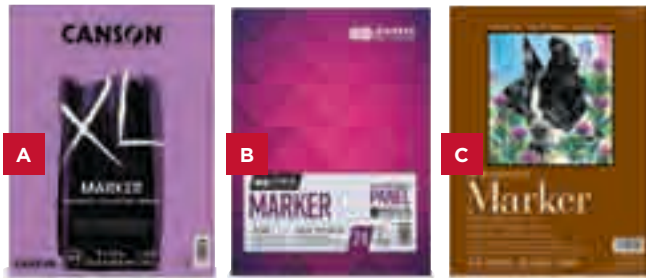

A Canson® XL Marker Paper Pads

This semi-transparent, acid-free white marker paper is great for drawing or design work, from rough sketches to finished presentations. It accepts both alcohol-based and solvent-based marker ink with no bleedthrough, yet responds beautifully to pens and pencils, too. For quality and more sheets per pad at a value price, choose Canson XL Marker Pads! 9" x 12" pad.

NUMBER	EACH	6/EA
A13671-1023	\$14.07	\$12.66

B Chartpak® Ad™ Marker Pads

Created especially for use with Chartpak Ad Markers, this 65 lb (175 gsm) bright white paper has a smooth surface and ink-receptive coating that assures clean edges when used with all alcohol and solvent markers. An innovative InkBlock™ panel prevents bleedthrough and indentations on the back side of the sheet, so you have full use of all 48 surfaces. 24-sheet pads.

NUMBER	SIZE	EACH	6/EA
A13338-1010	7" x 10"	\$13.70	\$12.33
A13338-1023	9" x 12"	16.75	15.07
A13338-1005	11" x 14"	20.35	18.31
A13338-1017	14" x 17"	25.95	23.36

C Strathmore® 400 Series Marker Pads

Ideal for all marker types, the paper in Strathmore 400 Series Marker Pads has a silky smooth surface. Markers glide easily for seamless blending, and colors retain their vibrancy or subtle hues. Gluebound pads with flip-over covers hold 24 sheets of 50.5 lb (190 gsm), acid-free paper (the 18" x 24" size has 15 sheets).

NUMBER	SIZE	EACH	3/EA
A13753-1021	6" x 8"	\$4.77	\$4.29
A13753-1023	9" x 12"	8.69	7.82
A13753-1005	11" x 14"	12.58	11.32
A13753-1009	18" x 24"	23.09	20.78

Strathmore® Artist Tiles

The perfect sizes and surfaces for creating small works of art with a variety of media. Ideal for pattern drawing and meditative art, these affordable, pre-cut tiles help make the process of combining repetitive marks, circles, lines, and forms both fun and easy to learn. Acid-free.

400 Series Black Artist Tiles

NUMBER	DESCRIPTION	SIZE	WEIGHT	EACH	6/EA
A13746-2026	Artagain, 30-Sheet Pad	6" x 6"	60 lb (160 gsm)	\$6.96	\$6.26

300 Series Bristol Artist Tiles

NUMBER	DESCRIPTION	SIZE	WEIGHT	EACH	6/EA
A13335-1044	Vellum, 20-Sheet Pack	4" x 4"	100 lb (270 gsm)	\$4.82	\$4.34
A13335-1066	Vellum, 20-Sheet Pad	6" x 6"	100 lb (270 gsm)	6.98	6.28

400 Series Recycled Sketch Artist Tiles

NUMBER	DESCRIPTION	SIZE	WEIGHT	EACH	6/EA
A13745-1006	70-Sheet Pad	6" x 6"	60 lb (89 gsm)	\$5.53	\$4.98

400 Series Watercolor Artist Tiles

NUMBER	DESCRIPTION	SIZE	WEIGHT	EACH	6/EA
A10194-1044	Cold Press, 10-Sheet Pack	4" x 4"	140 lb (300 gsm)	\$4.58	\$4.12
A10194-1066	Cold Press, 10-Sheet Pad	6" x 6"	140 lb (300 gsm)	6.87	6.18

400 Series Toned Artist Tiles

NUMBER	DESCRIPTION	COLOR	SIZE	WEIGHT	EACH	6/EA
A11991-8234	30-Sheet Pack	Toned Tan	4" x 4"	80 lb (216 gsm)	\$4.20	\$3.78
A11991-2504	30-Sheet Pack	Toned Gray	4" x 4"	80 lb (216 gsm)	4.20	3.78



Crescent® RendR Paper

A revolutionary bleedproof paper, RendR lets you create on every single page in your sketchbook, front and back. Even solvent-based markers and acrylic washes won't bleed through this acid-free, lignin-free paper. Hardbound Sketchbooks hold 48 sheets. Wirebound Sketchbook holds 32 sheets. Pads have 24 sheets. Soft Cover Sketchbooks hold 32 sheets, with a lay-flat design that eliminates the bump in the middle of the page, so you can create large, two-page drawings. 110 lb (180 gsm).

Sketchbooks

NUMBER	DESCRIPTION	SIZE	EACH	12/EA
A13655-1055	Hardbound	5-1/2" x 8-1/2"	\$17.36	\$15.62
A13655-1085	Hardbound	8-1/2" x 11"	25.43	22.89
A13655-1035	Lay Flat	3-1/2" x 5-1/2"	11.99	10.79
A13655-2085	Lay Flat	8-1/2" x 11"	18.92	17.03
A13655-1088	Wirebound	8" x 8"	17.62	15.86

Pads

NUMBER	SIZE	EACH	12/EA
A13655-1023	9" x 12"	\$11.81	\$10.63
A13655-1005	11" x 14"	17.62	15.86

Roll

NUMBER	SIZE	EACH	12/EA
A13655-1040	40" x 5 yd	\$27.14	\$24.43



D Bee Paper® Heavyweight Black Bristol Pads

Acid-free and lignin-free, this heavyweight black bristol accepts pastels, charcoal, colored pencils, gouache, poster paints, gel pens, paint markers, metallic mediums, and other light-colored opaque mediums. Bold, reversed highlights jump off the page! Excellent for use as scrapbook album pages, or as a heavyweight backing or mat for drawings or photos. 12-sheet pads. 130 lb (210 gsm).

NUMBER	SIZE	EACH	12/EA
A10286-1023	9" x 12"	\$19.55	\$17.59
A10286-1005	11" x 14"	29.99	26.99

E Bee Paper® Manga Artist Paper

Become a manga master! This acid-free, bleedproof, natural white paper has an ultra-smooth surface that's excellent for use with Copic markers, pen-and-ink, Crowquill pens, technical pens, and waterbased and permanent markers. In 30-sheet pads and 50-sheet packs. 110 lb (180 gsm) weight.

NUMBER	DESCRIPTION	EACH	12/EA
A12437-1001	8-1/2" x 11", Pad	\$14.15	\$12.75
A12437-1005	11" x 14", Pad	18.85	16.99
A10242-1085	8-1/2" x 11", Pack	18.25	16.45
A10242-1005	11" x 14", Pack	20.70	18.65

F Bee Paper® Pen Sketcher's Pads

Designed specifically for those who sketch in pen, these pads are well-suited for detail work. The heavyweight natural white sketch paper accepts pencil, ballpoint, pen-and-ink, and pens such as Sakura Micron. It features a smooth surface and is acid-free. Available in 50-sheet spiral-bound pads. 70 lb (114 gsm) weight.

NUMBER	DESCRIPTION	EACH	12/EA
A12444-1055	8-1/2" x 5-1/2", Landscape	\$6.35	\$5.72
A12444-1085	8-1/2" x 11", Portrait	6.10	5.49
A12444-1185	8-1/2" x 8-1/2"	8.60	7.75



Strathmore® 300 Series Bristol

An economical, 100 lb (260 gsm), bristol, available in two surfaces — choose Smooth for traditional and specialty pen-and-ink tools, and Vellum for pencil, charcoal, sketching sticks, airbrush, and pen-and-ink. Both also work well with markers. The 11" x 17" pads and packs each contain 24 sheets.

Pads

NUMBER	DESCRIPTION	EACH	12/EA
A13323-1037	Smooth	\$15.50	\$13.95
A13323-1017	Vellum	15.50	13.95

Packs

NUMBER	DESCRIPTION	EACH	12/EA
A13323-1057	Smooth	\$15.84	\$14.26

Strathmore® 500 Series Bristol

Created in 1893, this acid-free, 100% cotton, two-ply bristol is an industry standard. Choose the toothy finish of Vellum for use with graphite pencil, colored pencil, sketching sticks, and specialty pens and markers. Plate has an ultra-smooth finish that is ideal for detail work using traditional pen-and-ink tools, specialty pens and markers, and airbrush. Semi-Smooth has a slightly textured surface that is well-suited for pencil, pen-and-ink tools, and specialty pens and markers. The 11" x 17" pads and packs each contain 24 sheets.

Pads

NUMBER	DESCRIPTION	EACH	12/EA
A13322-1021	Plate	\$45.99	\$41.39
A13322-1011	Vellum	33.63	30.27

Packs

NUMBER	DESCRIPTION	EACH	12/EA
A13322-1041	Plate	\$52.23	\$46.99
A13322-1051	Semi-Smooth	45.86	41.27
A13322-1031	Vellum	34.56	31.10

Strathmore® 500 Series Marker Pads

Ideal for designers and graphic artists, these pads feature smooth-surfaced 100% cotton sheets that are semi-transparent/translucent yet accept heavy coverage of felt-tip markers without bleeding or feathering. White color guarantees optimal reflection of marker colors, excellent for layouts, rough comps, renderings, and for building colors and blending tones. Suitable for pencil, charcoal, pastels, and pen-and-ink. Acid-free. 50 sheets. 13.5 lb (50 gsm).

NUMBER	SIZE	EACH	12/EA
A12483-1023	9" x 12"	\$11.44	\$10.30

Canson® XL® Pen and Ink Pads

An ultra smooth, bright white, 80 lb (118 gsm) paper that renders clean, crisp lines with no feathering. These 60-sheet wirebound pads are perfect for use with felt tip pens, gel pens, and ballpoint pens, plus pigment and dye inks.

NUMBER	SIZE	EACH	3/EA
A10667-1010	7" x 10"	\$8.93	\$8.04
A10667-1012	9" x 12"	14.25	12.82



Canson® Fanboy™ Comic and Manga Boards and Paper

Industry standard sizes for comic and manga strips, pages, and covers. Extra-white, acid-free paper accepts ink, marker, felt tip, and pencil. Smooth texture is great for scanning. Erasable, no marker bleed-through, no buckling. Non-repro blue guidelines help you create panels and maintain character proportions. "How to Draw" instructions are included. Comic Strip Boards, Comic Book Art Boards, Manga Drawing Pad: smooth, 150 lb drawing paper. Layout Pages: smooth, 100 lb printed board for working out page ideas and story details. Comic-Manga Sketch Pad & Book: 65 lb paper for conceptualizing ideas; also accepts charcoal and pastel; erases cleanly.

NUMBER	DESCRIPTION	SIZE	GRID	SHTS/PK	EACH	6/EA
A12441-1010	Comic Strip Boards	5" x 17"	Yes	14	\$11.87	\$10.68
A12441-1030	Comic Book Art Boards	11" x 17"	Yes	24	24.66	22.19
A12441-1070	Comic-Manga Sketch Pad	8-1/2" x 11"	No	50	9.83	8.85
A12441-1080	Comic-Manga Sketch Book	8-1/2" x 11"	No	80	21.32	19.19
A12441-1100	Manga Drawing Pad	9" x 12"	No	20	11.87	10.68
A12441-1050	Layout Pages	8-1/2" x 11"	No	35	9.83	8.85



Canson® ACME Hole Punched Paper

This economical 20 lb bond paper is great for quick sketching. Pre-punched for standard ACME alignment of animation pages. Bulk packs of 100 sheets.

NUMBER	SIZE	EACH	3/EA
A10249-1085	8-1/2" x 11"	\$12.21	\$10.99
A10249-1010	10-1/2" x 12-1/2"	19.78	17.80

12f Finch Animation Paper

The pencil line quality on this paper is amazing, and the cleanup is even better! A high-quality, semi-opaque paper with good formation, 12f Finch Animation Paper erases easily without smearing or smudging. Choose punched or unpunched. 17 lb.

NUMBER	DESCRIPTION	SIZE	EACH	12/EA
A10268-1100	Pre-punched, 100 sheets	10-1/2" x 12-1/2"	\$12.99	\$11.69
A10268-1515	Pre-punched, 500 sheets	10-1/2" x 12-1/2"	62.37	56.13
A10268-1505	Unpunched, 500 sheets	10-1/2" x 12-1/2"	62.37	56.13

Acme Plastic Animation Pegbar

This industry-standard, unbreakable plastic pegbar assures better registration. Measuring 10" long with a 1/8" thick backing, it features a 5/16" peg at each end, and a round 1/4" peg in the center.

NUMBER	EACH	12/EA
A22746-1001	\$11.50	\$10.35



A Blick® Studio Tracing Paper Pads

This professional-quality, highly transparent tracing paper has a fine, smooth, hard surface that makes it excellent for tracing and visualizing with pencils, markers, or ink. 25 lb (41 gsm).

NUMBER	SIZE	EACH	12/EA	24/EA
A10609-3003	9" x 12"	\$3.97	\$3.57	\$3.39
A10609-3005	11" x 14"	5.32	4.79	4.55
A10609-3006	12" x 18"	6.74	6.07	5.77
A10609-3007	14" x 17"	6.38	5.74	5.45
A10609-3019	19" x 24"	18.94	17.05	16.20

NUMBER	SIZE	EACH	12/EA	24/EA
A10609-3103	9" x 12"	\$5.90	\$5.31	\$5.04
A10609-3105	11" x 14"	7.93	7.14	6.78
A10609-3106	12" x 18"	9.99	8.99	8.54
A10609-3107	14" x 17"	13.15	11.83	11.24
A10609-3119	19" x 24"	28.88	25.99	24.69

B Bienfang® Parchment 100 Fine Tracing Paper Pads

Very transparent with a smooth surface for use with pencil, pen, or markers. 25 lb (40 gsm) weight.

NUMBER	SIZE	EACH	12/EA	24/EA
A10602-1013	9" x 12"	\$10.14	\$9.13	\$8.68
A10602-1005	11" x 14"	13.89	12.50	11.88
A10602-1017	14" x 17"	19.70	17.73	16.85
A10602-1019	19" x 24"	35.85	32.27	30.67

NUMBER	SIZE	EACH	12/EA	24/EA
A10602-1003	9" x 12"	\$17.42	\$15.68	\$14.90
A10602-1015	11" x 14"	21.75	19.58	18.61
A10602-1007	14" x 17"	34.55	31.09	29.56
A10602-1009	19" x 24"	61.95	55.76	52.99

C Strathmore® 300 Series Tracing Paper Pads

Highly transparent parchment tracing paper accepts pencil, marker, and ink. Tapebound pads hold 50 sheets of 25 lb (41 gsm) paper.

NUMBER	SIZE	SHEETS	EACH	12/EA	24/EA
A10624-1023	9" x 12"	50	\$5.92	\$5.33	\$5.06
A10624-1005	11" x 14"	50	8.03	7.23	6.87
A10624-1017	14" x 17"	50	11.61	10.45	9.93
A10624-1000	19" x 24"	50	21.04	18.94	17.99

D Canson® Artist Series Tracing Paper Pads

This economical pad contains 50 sheets of 25 lb (40 gsm) tracing paper with an exceptionally transparent, smooth surface that is resistant to scraping. Suitable for pencil, ink, and marker.

NUMBER	SIZE	EACH	12/EA	24/EA
A10614-1023	9" x 12"	\$6.36	\$5.72	\$5.43
A10614-1005	11" x 14"	8.51	7.66	7.28
A10614-1117	14" x 17"	12.36	11.12	10.56
A10614-1009	19" x 12"	22.59	20.33	19.31

Blick® Studio Tracing Paper Rolls

This highly translucent 8 lb paper is excellent for sketching, layout, and preliminary detail drawing with pencils, markers, and ink. It has a smooth surface and erases well. Available in two colors, Blick Studio Tracing Rolls allow you to customize the size of the tracing paper to the project at hand.

Canary	NUMBER	SIZE	EACH	12/EA	24/EA
	A10530-4212	12" x 50 yd	\$13.08	\$11.78	\$11.18
	A10530-4218	18" x 50 yd	18.03	16.23	15.41
	A10530-4224	24" x 50 yd	24.05	21.64	20.57
White	NUMBER	SIZE	EACH	12/EA	24/EA
	A10535-1012	12" x 50 yd	\$13.08	\$11.78	\$11.18
	A10530-1218	18" x 50 yd	18.03	16.23	15.41
	A10535-1024	24" x 50 yd	24.05	21.64	20.57
	A10530-1236	36" x 50 yd	34.54	31.09	29.52

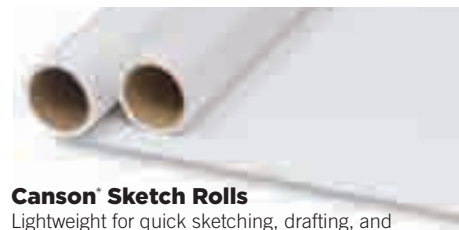

Canson® Sketch Rolls

Lightweight for quick sketching, drafting, and overlays. 18 lb (30 gsm) white sketching paper.

NUMBER	SIZE	EACH	12/EA	24/EA
A10214-1000	12" x 20"	\$11.23	\$10.11	\$9.60
A10214-1012	12" x 50"	21.24	19.12	18.16
A10214-1018	18" x 20"	14.99	13.49	12.82
A10214-1118	18" x 50"	28.48	25.63	24.35
A10214-1024	24" x 20"	18.94	17.05	16.20
A10214-1124	24" x 50"	38.49	34.64	32.91



Bienfang® Sketching & Tracing Paper Rolls

Lightweight roll papers, popular with architects, designers, and engineers. Perfect for developmental sketches, preliminary detail renderings, and quick roughs. Reproduces well.

Canary	NUMBER	WIDTH	EACH	12/EA	24/EA
	A10407-4212	12"	\$7.28	\$6.56	\$6.23
	A10407-4218	18"	9.12	8.21	7.80
	A10407-4224	24"	11.42	10.28	9.77

Canary	NUMBER	WIDTH	EACH	12/EA	24/EA
	A10407-4512	12"	\$13.03	\$11.72	\$11.14
	A10407-4518	18"	21.76	19.59	18.62
	A10407-4524	24"	25.58	23.03	21.88

White	NUMBER	WIDTH	EACH	12/EA	24/EA
	A10505-1112	12"	\$7.28	\$6.56	\$6.23
	A10505-1118	18"	9.12	8.21	7.80
	A10505-1124	24"	12.43	11.19	10.64

White	NUMBER	WIDTH	EACH	12/EA	24/EA
	A10505-9012	12"	\$13.03	\$11.72	\$11.14
	A10505-1018	18"	21.76	19.59	18.62
	A10505-1024	24"	25.58	23.03	21.88
	A10505-1036	36"	33.44	30.10	28.61

Pacon® Tracing Paper in Reams

Semi-transparent 25 lb (40 gsm) parchment can be used with pencil or pen for tracing or sketching. Economical 500-sheet ream is convenient for group activities. 9" x 12" sheets. Recyclable.

NUMBER	EACH	12/EA	24/EA
A10237-1023	\$39.63	\$35.67	\$33.88



Borden & Riley #116 Artist Sketch Vellum Pads

This versatile, heavyweight (90 lb) drawing paper has a medium texture that holds up well to most media, including pencils, charcoal, pastels, pen-and-ink, and light watercolor washes.

NUMBER	SIZE	EACH	12/EA
A10629-1023	9" x 12"	\$15.53	\$13.98
A10629-1005	11" x 14"	21.98	19.78
A10629-1017	14" x 17"	29.84	26.85
A10629-9024	24" x 36"	103.89	93.48

Bienfang® Cross-Section Gridded Paper

Popular for designing, drawing, pattern making, and more. Non-reproducing blue lines printed on both sides of the paper. Inch lines are bolder. Choose from three grid sizes (4 x 4 = 4 squares per inch, each square 1/4" and so on). 50-sheet pads.

8-1/2" x 11" Pads	NUMBER	GRID	EACH	12/EA	24/EA
	A10613-1095	4 x 4	\$5.87	\$5.33	\$5.07
	A10613-1105	8 x 8	5.87	5.33	5.07
	A10613-1085	10 x 10	5.87	5.33	5.07

11" x 17" Pads	NUMBER	GRID	EACH	12/EA	24/EA
	A10613-1016	4 x 4	\$9.73	\$8.76	\$8.33
	A10613-1026	8 x 8	9.73	8.76	8.33
	A10613-1006	10 x 10	9.73	8.76	8.33

17" x 22" 50-Sheet Pack	NUMBER	GRID	EACH	12/EA	24/EA
	A10613-1018	4 x 4	\$21.09	\$18.99	\$18.05



E Clearprint® 1000H Paper

America's Finest Technical Art Paper. Transparent, smooth, and uniform. Pen and pencil lines are sharp and clean with no feathery edges and no ghosting. Erase, redraw, then erase again. This remarkable paper retains its strength, stability, transparency, and printing qualities under exposure to heat, light, and atmosphere. It will not become yellow, brittle, or opaque with age. 16 lb (60 gsm) weight. 100% cotton; archival.

NUMBER	SIZE	EACH	12/EA	24/EA
A10901-1095	8-1/2" x 11"	\$9.69	\$8.72	\$8.29
A10901-1009	18" x 24"	31.64	28.48	27.07
A10901-1015	24" x 36"	47.99	43.19	41.06

NUMBER	SIZE	EACH	6/EA	12/EA
A11001-1085	8-1/2" x 11"	\$21.41	\$19.28	\$18.31
A11001-1009	18" x 24"	86.75	78.12	74.19

NUMBER	SIZE	EACH	12/EA	24/EA
A10901-1085	8-1/2" x 11"	\$35.95	\$32.35	\$30.75
A10901-1007	11" x 17"	69.85	62.87	59.77
A10901-1006	12" x 18"	83.19	74.88	71.18
A10901-1005	24" x 36"	260.12	234.10	222.60

NUMBER	SIZE	EACH	12/EA	24/EA
A11101-1018	18" x 5 yd	\$14.97	\$13.47	\$12.81
A11101-1024	24" x 5 yd	19.56	17.60	16.73
A11101-1066	36" x 5 yd	30.57	27.52	26.16
A11101-1001	24" x 20 yd	61.97	55.78	53.03
A11101-1046	36" x 20 yd	82.03	73.83	70.18
A11101-1036	36" x 50 yd	184.18	165.80	157.60

F Canson® Vidalon Vellum

High-transparency, neutral-pH, non-yellowing paper with an extra-smooth finish, suitable for line drawing, pencil, ink, technical pens, and more. Resists scraping and erasing. Tapebound pads contain 50, 55 lb (90 gsm) sheets.

NUMBER	SIZE	EACH	6/EA	12/EA
A10612-0023	9" x 12"	\$29.24	\$26.32	\$24.99
A10612-0005	11" x 14"	37.24	33.52	31.84
A10612-0017	14" x 17"	58.32	52.49	49.87
A10612-0009	19" x 24"	99.39	89.45	84.98

NUMBER	SIZE	EACH	25/EA	50/EA
A10521-1002	36" x 10 yds	\$3.47	\$3.12	\$2.96

NUMBER	SIZE	EACH	6/EA	12/EA
A10521-9000	36" x 10 yds	\$72.80	\$65.52	\$62.24

When ordering sheets of paper or board larger than 18" x 24", a handling fee may apply. See page 648.



G Canson® Pro Layout Marker Pads

This very smooth, white, 18 lb (70 gsm) layout paper is perfect for quick sketches with pencil, pen, or layout markers. It won't bleed, fade, or wrinkle. 50-sheet tapebound pads.

NUMBER	SIZE	EACH	6/EA	12/EA
A10607-1003	9" x 12"	\$15.20	\$13.68	\$12.99
A10607-1005	11" x 14"	23.51	21.16	20.10
A10607-1007	14" x 17"	26.26	23.63	22.45

H Bienfang® Graphics 360 Marker Paper

A 100% rag, non-bleeding, translucent marker paper that retains true color with permanent markers and watercolor markers. Also works well with pencil, charcoal, pastels, and pen-and-ink. 13.5 lb (50 gsm).

NUMBER	SIZE	EACH	12/EA	24/EA
A10604-1003	9" x 12"	\$10.85	\$9.87	\$9.38
A10604-1005	11" x 14"	14.91	13.57	12.89
A10604-1017	14" x 17"	21.13	19.22	18.27
A10604-1019	19" x 24"	40.94	37.25	35.40

NUMBER	SIZE	EACH	12/EA	24/EA
A10604-1103	9" x 12"	\$17.73	\$15.99	\$15.19
A10604-1105	11" x 14"	23.90	21.55	20.47
A10604-1007	14" x 17"	35.99	32.46	30.83

I Borden & Riley® Paris Bleedproof Paper for Pens

The smooth, hard surface of Paris paper is a convenient and economical alternative to bristol board. Brilliant white, crisp, and bleedproof, it is the ideal surface for detailed pen-and-ink illustrations rendered for reproduction with crow quill pens, broad drawing pens, calligraphy pens, or fountain pens. 108 lb.

NUMBER	SIZE	EACH	6/EA	12/EA
A10601-1153	9" x 12"	\$17.44	\$15.70	\$14.90
A10601-1155	11" x 14"	23.96	21.57	20.47
A10601-1157	14" x 17"	33.61	30.25	28.71
A10601-1159	19" x 24"	62.26	56.05	53.20

NUMBER	SIZE	EACH	3/EA</
--------	------	------	--------

Grafix® Clear Acetate Sheets and Rolls

Cellulose acetate, glossy on both sides. Use for protecting artwork, making overhead transparencies, overlays, screenprinting, and monoprinting. 100% biodegradable.

NUMBER	SIZE	WEIGHT	EACH	100/EA
A55501-1101	20" x 25"	.003"	\$1.81	\$1.63
A55501-1313	25" x 40"	.003"	3.45	3.10
A55501-1001	20" x 25"	.005"	2.56	2.30
A55501-1505	25" x 40"	.005"	5.11	4.60
A55501-1075	25" x 40"	.0075"	8.69	7.82
A55501-1100	25" x 40"	.010"	12.78	11.50

25-Sheet Pads

NUMBER	SIZE	WEIGHT	EACH	12/EA
A55501-1303	9" x 12"	.003"	\$13.70	\$12.33
A55501-1005	11" x 14"	.003"	19.47	17.52
A55501-1007	14" x 17"	.003"	26.77	24.09
A55501-1009	19" x 24"	.003"	49.91	44.92
A55501-1305	9" x 12"	.005"	19.30	17.37
A55501-1105	11" x 14"	.005"	27.15	24.43
A55501-1107	14" x 17"	.005"	38.58	34.72
A55501-1109	19" x 24"	.005"	68.29	61.46

50-Sheet Package

NUMBER	SIZE	WEIGHT	EACH	6/EA
A55501-1085	8-1/2" x 11"	.005"	\$28.62	\$25.75

Clear Acetate Rolls

NUMBER	SIZE	WEIGHT	EACH	6/EA
A55501-1103	25" x 12 ft	.003"	\$14.59	\$13.13
A55501-1203	25" x 25 ft	.003"	25.65	23.08
A55501-1403	25" x 50 ft	.003"	46.90	42.20
A55501-1003	25" x 100 ft	.003"	95.95	86.35
A55501-1603	50" x 25 ft	.003"	48.91	44.03
A55501-1703	50" x 50 ft	.003"	85.56	76.99
A55501-1503	50" x 100 ft	.003"	173.96	156.56
A55501-1315	25" x 12 ft	.005"	18.10	16.29
A55501-1405	25" x 25 ft	.005"	33.51	30.16
A55501-1605	25" x 50 ft	.005"	62.98	56.68
A55501-1205	25" x 100 ft	.005"	124.84	112.36
A55501-1805	50" x 25 ft	.005"	64.78	58.30
A55501-1905	50" x 50 ft	.005"	126.40	113.76
A55501-1705	50" x 100 ft	.005"	245.95	221.35

Grafix® Matte Acetate

One side is a non-glare, frosted surface that will accept pen-and-ink or pencil.

Sheets

NUMBER	SIZE	WEIGHT	EACH	100/EA
A55508-1001	20" x 25"	.003"	\$2.84	\$2.56
A55508-1003	25" x 40"	.003"	5.79	5.21

Rolls

NUMBER	SIZE	WEIGHT	EACH	6/EA
A55508-1103	25" x 50 ft	.003"	\$64.98	\$58.48
A55508-1203	50" x 12 ft	.003"	35.71	32.14



Grafix® Dura-Lar™ Wet Media Film

Treated on both sides to accept paint, marker, pen, and airbrush without beading, crawling, or chipping. 12-sheet pad.

Medium-weight (.004).

NUMBER	SIZE	EACH	12/EA
A55811-1023	9" x 12"	\$15.48	\$13.93
A55811-1005	11" x 14"	20.77	18.69
A55811-1017	14" x 17"	29.50	26.55
A55811-1024	19" x 24"	51.87	46.68
A55811-1025	20" x 25" Sheet	4.05	3.64

Grafix® Dura-Lar™

The acetate alternative!

For all of its usefulness, acetate does cause a few headaches: ink that won't stay, yellowing or graying with age, edges that curl. The alternatives are expensive and sometimes just don't suit the purpose.

Dura-Lar is the acetate alternative. It combines the best features of Mylar® and acetate, and offers a variety of products so that you can purchase the film that suits your needs precisely. It is always consistent in color and overall clarity, and won't discolor with age. Dura-Lar is archival-quality, safe for overlaying artwork, and it lays flat. It will remain dimensionally stable for as long as you need.

Grafix® Dura-Lar™ Clear Film

Designed for layouts, color separations, and overhead transparencies. Can also be used for screen printing or as a protective covering for your work.

Clear Sheets

NUMBER	SIZE	WEIGHT	EACH	50/EA
A55506-1301	20" x 25"	.003"	\$1.38	\$1.24
A55506-1103	25" x 40"	.003"	2.60	2.34
A55506-1501	20" x 25"	.005"	1.92	1.73
A55506-1205	25" x 40"	.005"	3.52	3.17
A55506-1307	25" x 40"	.007"	6.38	5.74
A55506-1100	25" x 40"	.010"	11.71	10.54
A55506-1009	18" x 24"	.015"	7.63	6.87
A55506-1109	18" x 24"	.020"	10.12	9.11
A55506-2003	18" x 24"	.030"	15.35	13.81
A55506-2004	18" x 24"	.040"	20.39	18.35

Classroom Pack — 100 sheets, .005 weight, 8-1/2" x 11"

NUMBER	EACH	6/EA
A55506-1000	\$41.50	\$37.35

Clear Pads — 25 sheets per pad.

NUMBER	SIZE	WEIGHT	EACH	6/EA
A55506-1303	9" x 12"	.003"	\$11.77	\$10.59
A55506-1005	11" x 14"	.003"	16.46	14.81
A55506-1107	14" x 17"	.003"	22.95	20.65
A55506-1209	19" x 24"	.003"	42.59	38.33
A55506-1305	9" x 12"	.005"	15.94	14.35
A55506-1105	11" x 14"	.005"	21.96	19.76
A55506-1207	14" x 17"	.005"	32.41	29.17
A55506-1309	19" x 24"	.005"	59.81	53.83

Clear Overlay Rolls

NUMBER	SIZE	WEIGHT	EACH	6/EA
A55506-1101	20" x 12 ft	.003"	\$10.77	\$9.69
A55506-1401	20" x 25 ft	.003"	17.60	15.84
A55506-1003	20" x 50 ft	.003"	30.59	27.53
A55506-1006	40" x 25 ft	.003"	33.06	29.75
A55506-1407	40" x 50 ft	.003"	58.76	52.88
A55506-1409	40" x 100 ft	.003"	115.10	103.59
A55506-1201	20" x 12 ft	.005"	15.17	13.65
A55506-1601	20" x 25 ft	.005"	25.72	23.15
A55506-1001	20" x 100 ft	.005"	88.17	79.35
A55506-1040	40" x 12 ft	.005"	25.24	22.72
A55506-1106	40" x 25 ft	.005"	47.51	42.76
A55506-1507	40" x 50 ft	.005"	89.38	80.44
A55506-1509	40" x 100 ft	.005"	172.93	155.64
A55506-1140	40" x 12 ft	.007"	41.64	37.48
A55506-1206	40" x 25 ft	.007"	80.82	72.74
A55506-1607	40" x 50 ft	.007"	154.03	138.63

Grafix® Dura-Lar™ Clear Art Wrap Rolls

Ultra-light, designed for protecting artwork from dust and dampness, while allowing complete and unobstructed viewing.

NUMBER	SIZE	WEIGHT	EACH	6/EA
A55506-1008	27" x 12 ft	.001"	\$8.10	\$7.29
A55506-1027	27" x 50 ft	.001"	22.71	20.44
A55506-1001	54" x 50 ft	.001"	45.12	40.61
A55506-1707	20" x 12 ft	.002"	9.75	8.77
A55506-1050	20" x 50 ft	.002"	29.26	26.33
A55506-1707	40" x 50 ft	.002"	51.99	46.79

Guide to Dura-Lar™ Weights

.001" Light

.002" Light

.003" Medium

.004" Medium

.005" Medium

.007" Heavy

.010" Heavy

.015" Extra Heavy

.020" Extra Heavy

Grafix® Dura-Lar™ Clear Adhesive-Backed Film

This pressure-sensitive Dura-Lar product is a .005", medium-weight, clear film with a permanent adhesive backing. Ideal for use in laminating or as a protective covering. Acid-free, archival-quality. Available in rolls and sheets.

Rolls

NUMBER	SIZE	EACH	6/EA
A55525-2020	20" x 25 ft	\$88.62	\$79.76
A55525-2040	40" x 25 ft	171.94	154.75

Sheets

NUMBER	SIZE	EACH	25/EA
A55525-1021	20" x 25"	\$7.58	\$6.82
A55525-1041	40" x 25"	14.51	13.06

Grafix® Dura-Lar™ Matte

Both sides have a matte surface that accepts ink without feathering, as well as pencils and other drawing media. Surface is erasable. 25-sheet pads. .005 weight.

NUMBER	SIZE	EACH	6/EA
A55505-1305	9" x 12"	\$21.76	\$19.58
A55505-1005	11" x 14"	34.12	30.71
A55505-1007	14" x 17"	45.21	40.69



Grafix® Stencil Film

This tough, non-tearing polyester stencil film lets you create or copy designs and turn them instantly into templates. Simply draw or trace your design with a pen, cut it out, and you're ready to stencil. Cuts easily with scissors, craft knife, die-cut machine, or stencil cutter. Can be used over and over without tearing or losing its ability to lay flat. Package of four 9" x 12" sheets in light blue or matte finish.

NUMBER	DESCRIPTION	EACH	12/EA
A23204-5007	Blue Film, .007"	\$7.14	\$6.43
A23204-0052	Matte Film, .005"	7.14	6.43



Clearprint® Drafting & Design Fade-Out Vellum

The finest product you can buy for manual drafting, tracing, and drawing. This 100% rag cotton fiber media is made transparent without solvents to produce the proper translucency. Also includes Clearprint's super archival-quality strength and erasability with no ghosting. For pencil or ink. The 16 lb sheets have a fade-out blue grid. 50-sheet pads.

8-1/2" x 11"

NUMBER	GRID	EACH	6/EA	12/EA
A11001-1104	4" x 4"	\$28.63	\$25.77	\$24.49
A11001-1000	8" x 8"	28.63	25.77	24.49
A11001-1100	10" x 10"	28.63	25.77	24.49

11" x 17"

NUMBER	GRID	EACH	6/EA	12/EA
A11001-1016	4" x 4"	\$51.61	\$46.44	\$44.09
A11001-1018	8" x 8"	51.61	46.44	44.09
A11001-1014	10" x 10"	51.61	46.44	44.09
A11001-2017	11" x 17" Isometric	51.61	46.44	44.09



Clearprint® Field Books

Filled with 50 sheets of Clearprint's most popular 100% cotton vellum — 1000H — these field books are available in both plain and gridded versions (which include 4" x 4" non-repro blue grids). Insert the included InkBlock™ panel underneath your work to prevent marks and indentations on the sheet below. Heavy, customizable vellum cover.

NUMBER	DESCRIPTION	SIZE	EACH	6/EA
A10927-1006	Plain	4" x 6"	\$9.42	\$8.47
A10927-1021	Plain	6" x 8"	13.84	12.45
A10927-1011	Plain	8-1/2" x 11"	23.28	20.96
A10927-1106	Grid	4" x 6"	9.42	8.47
A10927-1121	Grid	6" x 8"	13.84	12.45
A10927-1111	Grid	8-1/2" x 11"	23.28	20.96

When ordering sheets of paper or board larger than 18" x 24", a handling fee may apply. See page 648.



Grafix® Clear-Lay™ Plastic Film

Optical clarity and dimensional stability at an economical price. This rigid, flat PVC film is designed for overlays, stencils, and protective coverings. Each package contains 25 clear .005 gauge sheets. Acid-free and archival.

NUMBER	SIZE	EACH	12/EA
A55519-1023	9" x 12"	\$13.84	\$12.46
A55519-1005	11" x 14"	19.75	17.77
A55519-1017	14" x 17"	28.11	25.30
A55519-1024	19" x 24"	49.17	44.25

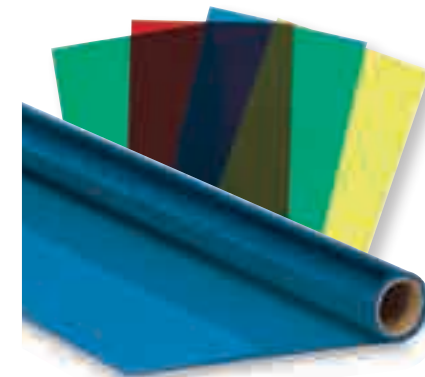

Grafix® Clear-Lay™ Assorted Color Pack

Assorted Color Pack — Pack of 25, 9" x 12" sheets includes five each of Red, Clear, Blue, Green, and Yellow.

NUMBER	EACH	6/EA
A55503-0029	\$28.89	\$25.99

</

Canson® Colorline® Art Papers

Brilliant colors!

Versatile and heavyweight, this lightly grained drawing paper comes in an exciting palette of bright colors. The perfect "step-up" from construction paper, it's ideal for school projects, signs, posters, cards, collage, and craft projects. 92 lb (150 gsm). Acid-free and chlorine-free. 19" x 25" sheets. Colors can be assorted for quantity pricing.

COLOR		COLOR	
Black	A11273-2002	Lilac	A11273-6132
Bright Green	A11273-7259	Moss Green	A11273-7522
Buttercup	A11273-4469	Nut	A11273-8012
Canary Yellow	A11273-4252	Off White	A11273-1589
Clementine	A11273-1002	Pearl White	A11273-1099
Cobalt Violet	A11273-6919	Pebble Gray	A11273-2509
Coral	A11273-3249	Primary Blue	A11273-5922
Cream	A11273-1102	Red	A11273-3002
Dark Gray	A11273-5239	Rose Petal	A11273-3172
Dark Red	A11273-3039	Royal Blue	A11273-5072
Fuchsia	A11273-4542	Sky Blue	A11273-5092
Ivory	A11273-1069	Tomato	A11273-3012
Khaki Green	A11273-7699	Turquoise Blue	A11273-5132
Leather	A11273-8912	Ultramarine	A11273-5232
Light Gray	A11273-2512	Violet	A11273-6502
Lime Green	A11273-7239	White	A11273-1062
		EACH	10/EA
		\$1.80	\$1.62



A



Paper Accents® Cardstock Stash Packs

An economical way to purchase cardstock for your classroom or studio, each Paper Accents Cardstock Stash Pack includes a range of colors that represent a favorite season or theme. Each pack includes 40, 8-1/2" x 11" sheets of acid-free, lignin-free cardstock. For colors, visit DickBlick.com.

Autumn — Includes eight sheets each of Yellow, Green, Burgundy, Brown, and Burnt Orange.

NUMBER	EACH	6/EA
A14203-1002	\$8.80	\$7.92

Fruity — Includes eight sheets each of Orange, Yellow, Green, Purple, and Red.

NUMBER	EACH	6/EA
A14203-1006	\$8.80	\$7.92

Ocean — Includes eight sheets each of Navy, Turquoise, Tan, Teal, and Aqua.

NUMBER	EACH	6/EA
A14203-1004	\$8.80	\$7.92

Summer — Includes eight sheets each of Yellow, Red, Turquoise, Orange, and Green.

NUMBER	EACH	6/EA
A14203-1001	\$8.80	\$7.92

Tea Party — Includes eight sheets each of Purple, Pink, Blue, Green, and Yellow.

NUMBER	EACH	6/EA
A14203-1005	\$8.80	\$7.92

Unicorn — Includes eight sheets each of Navy, Turquoise, Tan, Teal, and Aqua.

NUMBER	EACH	6/EA
A14203-1003	\$8.80	\$7.92

Paper Accents® Glitter Cardstock

This archival-quality, heavyweight (85 lb) cardstock is great for adding glitter and shine to cards, invitations, scrapbook pages, memory albums, and more. Available in 8-1/2" x 11" sheets, these buffered, acid-free, lignin-free sheets are ideal for beautiful paper crafts that last. 5-packs.

NUMBER	COLOR	EACH	6/EA
A14202-2020	Black	\$8.80	\$7.92
A14202-9010	Gold	8.80	7.92
A14202-7010	Green	8.80	7.92
A14202-5220	Jewel Blue	8.80	7.92
A14202-3010	Red	8.80	7.92
A14202-9330	Silver	8.80	7.92
A14202-1020	White	8.80	7.92



B

A-B Crayola® Construction Paper

Construction paper is a must-have for school and home craft projects. Available in handy, multi-color packs of standard or giant-size sheets, as well as a pack of 900 pre-cut stars, hearts, circles, crescents, and geometric paper shapes, Crayola Construction Paper adds vivid color to artwork, classroom decorations, bulletin boards, and more. Visit DickBlick.com for color assortments.

NUMBER	DESCRIPTION	EACH	12/EA
A11425-1148	A Giant, 12" x 18", 48 Sheets	\$5.06	\$4.55
A11425-1048	B Paper Shapes, 48 Sheets	7.32	6.59
A11425-1096	9" x 12", 96 Sheets	3.62	3.26
A11425-1240	9" x 12", 240 Sheets	8.67	7.80



BLICK® construction paper & cardstock

Blick® 140 lb Premium Cardstock

This high-quality premium cardstock is affordably priced in sheet quantities, so you buy only what you need. Holds paint and marker without bleeding and makes larger projects possible. 18" x 24". Colors can be assorted for quantity pricing.

COLOR		EACH	10/EA	20/EA
Black	A11408-2009	\$2.83	\$2.55	\$2.42
Blue	A11408-5019	2.83	2.55	2.42
Burnt Orange	A11408-4529	2.83	2.55	2.42
Chocolate Brown	A11408-8109	2.83	2.55	2.42
Dark Blue	A11408-5049	2.83	2.55	2.42
Dark Brown	A11408-8039	2.83	2.55	2.42
Dark Green	A11408-7039	2.83	2.55	2.42
Festive Red	A11408-3419	2.83	2.55	2.42
Gold	A11408-4079	2.83	2.55	2.42
Holiday Green	A11408-7099	2.83	2.55	2.42
Holiday Red	A11408-3469	2.83	2.55	2.42
Lemon Yellow	A11408-4119	2.83	2.55	2.42
Lilac	A11408-6139	2.83	2.55	2.42
Lime	A11408-7239	2.83	2.55	2.42
Magenta	A11408-3079	2.83	2.55	2.42
Orange	A11408-4519	2.83	2.55	2.42
Pearl Gray	A11408-2409	2.83	2.55	2.42
Pink	A11408-3069	2.83	2.55	2.42
Raspberry	A11408-3369	2.83	2.55	2.42
Scotch Gray	A11408-2569	2.83	2.55	2.42
Silver	A11408-2599	2.83	2.55	2.42
Sky Blue	A11408-5099	2.83	2.55	2.42
Turquoise	A11408-5139	2.83	2.55	2.42
Violet	A11408-6509	2.83	2.55	2.42
White	A11408-1029	2.83	2.55	2.42
Yellow	A11408-4019	2.83	2.55	2.42
Yellow-Orange	A11408-4259	2.83	2.55	2.42



COLOR		9" X 12"	12" X 18"
Assorted	A11420-1003		A11420-1006
		EACH 25/EA	EACH 25/EA
		\$2.09 \$1.88	\$4.08 \$3.68

Blick® 80 lb Premium Construction Paper

High-quality, affordable construction paper holds paint and marker without bleeding so it's perfect for drawing, cutting, and folding projects. Acid-free, lignin-free, and light-stable. Assorted pack contains five sheets of Turquoise, Black, Brown, Green, Blue, Purple, Red, Orange, Yellow, and White.



80 lb Weight (130 gsm) — 50-sheet package.

COLOR	9" X 12"	12" X 18"	19-1/2" X 27-1/2" SHEETS
Assorted	A11409-1003	A11409-1006	—
Black	A11409-2003	A11409-2006	A11409-2020
Blue	A11409-5013	A11409-5016	A11409-5230
Burnt Orange	A11409-4523	A11409-4526	—
Chocolate Brown	A11409-8103	A11409-8106	A11409-8100
Dark Blue	A11409-5043	A11409-5046	A11409-5050
Dark Brown	A11409-8033	A11409-8036	—
Dark Green	A11409-7033	A11409-7036	A11409-7190
Holiday Green	A11409-7093	A11409-7096	A11409-7050
Holiday Red	A11409-3463	A11409-3466	A11409-3730
Lemon Yellow	A11409-4113	A11409-4116	A11409-4060
Lilac	A11409-6133	A11409-6136	A11409-6410
Lime	A11409-7233	A11409-7236	A11409-7440
Magenta	A11409-3073	A11409-3076	A11409-3320
Orange	A11409-4513	A11409-4516	A11409-4510
Pearl Gray	A11409-2403	A11409-2406	A11409-2590
Pink	A11409-3063	A11409-3066	A11409-3710
Raspberry	A11409-3363	A11409-3366	A11409-3060
Scotch Gray	A11409-2563	A11409-2566	A11409-2690
Sky Blue	A11409-5093	A11409-5096	A11409-5090
Turquoise	A11409-5133	A11409-5136	A11409-5320
Violet	A11409-6503	A11409-6506	A11409-6030
White	A11409-1023	A11409-1026	A11409-1020
Yellow	A11409-4013	A11409-4016	A11409-4320
Yellow-Orange	A11409-4253	A11409-4256	A11409-4420

	EACH	\$3.76	EACH	\$7.55	EACH	\$1.45
	12/EA	3.36	12/EA	6.79	12/EA	1.30
	24/EA	3.20	24/EA	6.45	24/EA	1.24

80 lb Weight (130 gsm) — 50-sheet package.

COLOR	9" X 12"	12" X 18"	19-1/2" X 27-1/2" SHEETS	
Gold	A11409-4073	A11409-4076	A11409-9010	
Silver	A11409-2593	A11409-2596	A11409-9330	
	EACH	\$7.90	EACH \$11.42	EACH \$1.45
	12/EA	7.10	12/EA 10.28	12/EA 1.30
	24/EA	6.75	24/EA 9.75	24/EA 1.24

Blick® Economy Construction Paper

Economical, all-purpose construction paper is easy on the school budget. Great for cutting and folding projects in the classroom because it's thicker and more rigid than other lightweight construction paper. Available in 10 colors and two sizes. 50-sheet packages. Assorted pack contains five sheets each of Black, Blue, Brown, Holiday Green, Orange, Pink, Scarlet, Violet, White, and Yellow. Recyclable. 58 lb.

2,000 sheets!

TRU-RAY

Tru-Ray 76 lb Construction Paper Class Pack

Includes 32 packs of 9" x 12" paper, and eight packs of 12" x 18" paper. Each pack includes 50 sheets in 10 assorted colors, for a total of 2,000 sheets! Color assortment varies per pack.

NUMBER	EACH	10/EA	25/EA
A11406-1009	\$142.99	\$128.69	



Assorted



Assorted Bright



Assorted Cool



Assorted Warm



Assorted Hot

Tru-Ray 76 lb Construction Paper 50-Sheet Assortments

Assorted Colors — Contains five sheets each of 10 colors, including Black, Blue, Dark Brown, Festive Green, Orange, Pink, Red, Purple, White, and Yellow.

NUMBER	SIZE	EACH	10/EA	25/EA
A11406-0039	9" x 12"	\$3.08	\$2.77	\$2.63
A11406-0079	12" x 18"	5.80	5.34	5.07
A11406-0099	18" x 24"	10.59	9.51	9.03
A11406-0059	24" x 36"	24.14	21.73	20.64

Assorted Bright Colors — Contains five sheets each of 10 colors, including Brilliant Lime, Festive Green, Festive Red, Gold, Atomic Blue, Magenta, Pumpkin, Shocking Pink, Turquoise, and Violet.

NUMBER	SIZE	EACH	10/EA	25/EA
A11406-0139	9" x 12"	\$3.80	\$3.41	\$3.24
A11406-0179	12" x 18"	6.13	5.51	5.24

Assorted Cool Colors — Contains five sheets each of 10 colors, including Blue, Brilliant Lime, Dark Lime, Festive Green, Holiday Green, Lilac, Royal Blue, Sky Blue, Turquoise, and Violet.

NUMBER	SIZE	EACH	10/EA	25/EA
A11406-1123	9" x 12"	\$3.80	\$3.41	\$3.24
A11406-1106	12" x 18"	6.13	5.51	5.24

Assorted Warm Colors — Contains five sheets each of 10 colors, including Festive Red, Gold, Holiday Red, Dark Pink, Light Yellow, Orange, Pink, Electric Orange, Shocking Pink, and Yellow.

NUMBER	SIZE	EACH	10/EA	25/EA
A11406-2023	9" x 12"	\$3.80	\$3.41	\$3.24
A11406-2006	12" x 18"	6.13	5.51	5.24

Assorted Hot Colors — Contains 10 sheets each of five colors, including Atomic Blue, Brilliant Lime, Electric Orange, Lively Lemon, and Shocking Pink.

NUMBER	SIZE	EACH	10/EA	25/EA
A11406-0239	9" x 12"	\$3.80	\$3.41	\$3.24
A11406-0279	12" x 18"	6.13	5.51	5.24

Tru-Ray 76 lb Construction Paper

This brightly colored paper is 100% vat-dyed and acid-free and will continue to look fresh and new. Made with long, strong 100% sulphite fibers, this heavyweight paper is tough enough to take scoring, folding, and curling without cracking or tearing. Contains 50% recycled content. Available in four sizes in 50-sheet packs. Colors can be assorted by size for quantity pricing.

COLOR	9" X 12"	12" X 18"	18" X 24"	24" X 36"
Atomic Blue	A11406-5013	A11406-5017	—	—
Black	A11406-2003	A11406-2007	A11406-2009	A11406-2005
Blue	A11406-5003	A11406-5007	A11406-5009	—
Brilliant Lime	A11406-7143	A11406-7147	A11406-7149	—
Dark Brown	A11406-8033	A11406-8037	A11406-8039	—
Electric Orange	A11406-4523	A11406-4527	—	—
Festive Green	A11406-7233	A11406-7237	A11406-7239	—
Festive Red	A11406-3413	A11406-3417	A11406-3419	—
Gold	A11406-2073	A11406-2077	A11406-2079	—
Gray	A11406-2223	A11406-2227	A11406-2229	—
Holiday Green	A11406-7093	A11406-7097	A11406-7099	—
Holiday Red	A11406-3463	A11406-3467	A11406-3469	—
Lively Lemon	A11406-4023	A11406-4027	—	—
Magenta	A11406-3053	A11406-3057	A11406-3059	—
Orange	A11406-4513	A11406-4517	A11406-4519	—
Pink	A11406-3063	A11406-3067	A11406-3079	—
Purple	A11406-6013	A11406-6017	A11406-6019	—
Royal Blue	A11406-5073	A11406-5077	A11406-5079	—
Salmon	A11406-3693	A11406-3697	—	—
Shocking Pink	A11406-3733	A11406-3737	A11406-3069	—
Sky Blue	A11406-5083	A11406-5087	A11406-5089	—
Slate Gray	A11406-5353	A11406-5357	—	—
Turquoise	A11406-5123	A11406-5127	A11406-5139	—
Violet	A11406-6503	A11406-6507	A11406-6509	—
Warm Brown	A11406-8543	A11406-8547	A11406-8549	—
White	A11406-1023	A11406-1027	A11406-1029	A11406-1025
Yellow	A11406-4003	A11406-4007	A11406-4029	—

NUMBER	SIZE	EACH	10/EA	25/EA
A11406-1003	240 Sheets 9" x 12"	\$15.56	\$13.99	
A11406-1006	120 Sheets 12" x 18"	15.56	13.99	

Tru-Ray Smart-Stack 76 lb Construction Paper Assortments

Tru-Ray's popular sulphite construction paper in 11 of its most popular colors! Tough enough to score, fold, and curl with no cracking or tearing. Acid-free and fade-resistant. 50% recycled content.

NUMBER	DESCRIPTION	SIZE	EACH	10/EA
A11406-1003	240 Sheets	9" x 12"	\$15.56	\$13.99
A11406-1006	120 Sheets	12" x 18"	15.56	13.99



Classroom Keepers Construction Paper Storage

The 9" x 12" size holds up to 15 different colors of 9" x 12" paper in slots measuring 12-1/2" x 9-1/4" x 1-1/2"H. The 12" x 18" size holds up to 10 different colors of 12" x 18" paper in slots measuring 12-1/4" x 18-1/4" x 3"H.

NUMBER	SIZE	EACH	6/EA
A11423-1020	9" x 12"	\$29.30	\$26.37
A11423-9012	12" x 18"	35.57	31.99



Pacon Scrapbook Paper

Scrapbooking encourages students to express themselves in a three-dimensional way while honing their organizational, writing, and artistic skills. This paper can also be used for cardmaking, stamping, and crafts. This heavyweight 65 lb cardstock is acid-free and lignin-free, making it ideal for archival projects. The 20-sheet pack includes one sheet each of 20 colors. The 160-sheet pack includes eight each of 20 colors. Includes Brights, Pastels, Electrics, and Neutrals. 12" x 12" sheets. Recyclable.

NUMBER	DESCRIPTION	EACH	15/EA	30/EA
A12742-1009	160-Sheet Pack	\$27.32	\$24.59	\$23.36



American Crafts Textured Cardstock Paper Packs

This cardstock comes in a variety of classic, stylish colors, ideal for cards, invitations, or for adding a textured look to craft projects. Each pack holds 25 sheets of heavyweight, textured, acid-free cardstock in a variety of colors. An open-corner box keeps sheets protected yet accessible. 80 lb (218 gsm).

NUMBER	COLOR	EACH	12/EA
A11757-2024	Black	\$13.77	\$12.39
A11757-5914	Denim	13.77	12.39
A11757-3684	Rouge	13.77	12.39
A11757-1104	Vanilla	13.77	12.39



Creative Collection Premium Cardstock Packs

A variety of textures and vibrant colors! Perfect for many art projects including card making and scrapbooking, this high-quality cardstock is easy to score, and folds and cuts cleanly. Compatible with laser and inkjet printers. Acid-free and lignin-free.

NUMBER	DESCRIPTION	WEIGHT	EACH	6/EA	12/EA
A11323-1070	Double Color, 5 Color Combinations	70lb	\$6.07	\$5.47	\$5.20
A11323-1065	Metallics, 4 Colors	65lb	9.76	8.79	8.34

RiteCo Construction Paper

This brightly colored, high-quality construction paper has superior strength and durability for art and craft projects of all kinds. Made using an environmentally friendly process, it contains long fibers that fold without cracking and cut evenly for the most detailed artwork and projects. Film-wrapped packages hold 50 sheets of 60 lb construction paper. Colors can be assorted for quantity pricing.

COLOR	9" X 12"	12" X 18"
Assorted	A11446-1003	A11446-1006
Black	A11446-2023	A11446-2026
Bright Blue	A11446-5473	A11446-5476
Bright Green	A11446-7253	A11446-7256
Bright White	A11446-1153	A11446-1156
Brown	A11446-8003	A11446-8006
Dark Blue	A11446-5033	A11446-5036
Dark Brown	A11446-8033	A11446-8036
Gray	A11446-2503	A11446-2506
Holiday Green	A11446-7933	A11446-7936
Holiday Red	A11446-3743	A11446-3746
Hot Pink	A11446-3293	A11446-3296
Light Blue	A11446-5483	A11446-5486
Light Brown	A11446-8013	A11446-8016
Light Green	A11446-8043	A11446-8046
Lilac	A11446-6033	A11446-6036
Magenta	A11446-3043	A11446-3046
Orange	A11446-4513	A11446-4516
Pink	A11446-3063	A11446-3066
Scarlet	A11446-3083	A11446-3086
Turquoise	A11446-5113	A11446-5116
Violet	A11446-6063	A11446-6066
Yellow	A11446-4013	A11446-4016

	EACH	10/EA	25/EA	EACH	10/EA	25/EA
	\$1.64	1.48	1.41	\$3.25	2.93	2.78

American Crafts Cardstock Paper Packs

These versatile cardstock packs are ideal for making seasonal, holiday, or color-themed decorations and papercrafts. Each pack holds 60 sheets of heavyweight, textured, acid-free cardstock in a variety of colors. An open-corner box keeps sheets protected yet accessible. 80 lb (218 gsm).

NUMBER	COLOR	EACH	12/EA
A12764-1080	Earth Tones	\$24.16	\$21.74
A12764-1070	Jewel Tones	24.16	21.74
A12764-1120	Pastels	24.16	21.74
A12764-1090	Primaries	24.16	21.74



Roylco Double Color Cardstock

Create double-color crafts with these sturdy 8" x 9" cardstock sheets. They're great for making vibrant greeting cards and invitations — or for cutting shapes to add a splash of color to crafts.

NUMBER	DESCRIPTION	EACH	6/EA
A12611-1000	100 Sheets	\$20.14	\$18.12

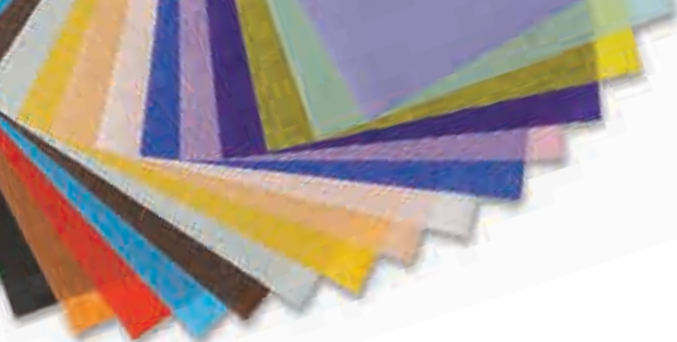

BLICK® art tissue

The brightest colors available in tissue paper. Each crisp color is reasonably lightfast and, under normal conditions, will not bleed. Great for tissue collage, decorating, wrapping, and crafts. **Colors (including Pure White below) can be assorted by size for quantity pricing.**

COLOR	A 50-SHEET PACKAGE 12" X 18"	B 24-SHEET PACKAGE 20" X 30"	C 480-SHEET REAM 20" X 30"
Apple Green	A11308-7177	A11308-7173	A11303-7183
Black	A11308-2007	A11308-2003	A11303-2013
Brown	A11308-8007	A11308-8003	A11303-8013
Cerise	A11308-3237	A11308-3233	A11303-3243
Dark Pink	A11308-3327	A11308-3323	A11303-3333
Gold	A11308-4057	A11308-4053	A11303-4063
Holly Green	A11308-7277	A11308-7273	A11303-7283
Lavender	A11308-6127	A11308-6123	A11303-6133
Light Blue	A11308-5017	A11308-5013	A11303-5023
Light Pink	A11308-3497	A11308-3493	A11303-3503
Orange	A11308-4507	A11308-4503	A11303-4513
Purple	A11308-6007	A11308-6003	A11303-6013
Scarlet	A11308-3087	A11308-3083	A11303-3093
Turquoise	A11308-5117	A11308-5113	A11303-5123
Yellow	A11308-4007	A11308-4003	A11303-4013

A 50-Sheet Package, 12" x 18" — Each package has 50 sheets of ONE color. Specify color above.

NUMBER	EACH	24/EA	36/EA
A11308-1497	\$4.45	\$3.99	\$3.79

B 24-Sheet Package, 20" x 30" — Each package has 24 sheets of ONE color. Specify color above.

NUMBER	EACH	10/EA	20/EA
A11308-1493	\$3.16	\$2.84	\$2.70

C 480-Sheet Ream, 20" x 30" — Each package has 480 sheets of ONE color. Specify color above.

NUMBER	EACH	10/EA	20/EA
A11303-1513	\$69.52	\$62.59	\$59.49

Blick® Pure White Tissue Paper

Can be assorted by size with colors above for quantity pricing.

NUMBER	EACH	24/EA	36/EA
A11308-1497	\$4.45	\$3.99	\$3.79

NUMBER	EACH	10/EA	20/EA
A11308-1493	\$3.16	\$2.84	\$2.70

NUMBER	EACH	10/EA	20/EA
A11303-1513	\$40.06	\$36.07	\$34.28

Blick® Colored Tissue Assortments

The same colored tissue listed above in packages of assorted colors.

50-Sheet Package, 12" x 18" — Assortment of 10 colors.

NUMBER	EACH	24/EA	36/EA
A11308-1006	\$5.14	\$4.63	\$4.40

100-Sheet Package, 12" x 18" — Assortment of 20 colors.

NUMBER	EACH	24/EA	36/EA
A11308-1007	\$9.95	\$8.95	\$8.50

100-Sheet Package, 20" x 30" — Assortment of 20 colors.

NUMBER	EACH	10/EA	20/EA
A11308-1003	\$16.42	\$14.78	\$14.04

480-Sheet Package, 20" x 30" — Assortment of 20 colors.

NUMBER	EACH	10/EA	20/EA
A11308-1009	\$58.97	\$53.07	\$50.42



Assorted

Spectra® Deluxe Bleeding Art Tissue™

The finest-quality tissue made. The wide range of beautiful colors will motivate students of all ages to create exciting art projects. Colors will bleed. **Colors can be assorted for quantity pricing.**

24-Sheet Package, 20" x 30" — Each package has 24 sheets of ONE color.

COLOR	NUMBER	EACH	10/EA	20/EA
Apple Green	A11306-7173	\$3.99	\$3.59	\$3.41
Azure Blue	A11306-5913	3.99	3.59	3.41
Black	A11306-2003	3.99	3.59	3.41
Blush Pink	A11306-3123	3.99	3.59	3.41
Canary	A11306-4263	3.99	3.59	3.41
Cerise	A11306-6023	3.99	3.59	3.41
Chinese Red	A11306-3273	3.99	3.59	3.41
Dark Pink	A11306-3323	3.99	3.59	3.41
Emerald	A11306-7053	3.99	3.59	3.41
French Blue	A11306-5573	3.99	3.59	3.41
Goldenrod	A11306-4533	3.99	3.59	3.41
Medium Blue	A11306-5023	3.99	3.59	3.41
National Blue	A11306-5283	3.99	3.59	3.41
National Red	A11306-3593	3.99	3.59	3.41
Orange	A11306-4503	3.99	3.59	3.41
Orchid	A11306-6153	3.99	3.59	3.41
Pansy	A11306-6163	3.99	3.59	3.41
Purple	A11306-6003	3.99	3.59	3.41
Scarlet	A11306-3083	3.99	3.59	3.41
Seal Brown	A11306-8483	3.99	3.59	3.41
Sky Blue	A11306-5073	3.99	3.59	3.41
Spring Green	A11306-7443	3.99	3.59	3.41

Spectra® White Art Tissue™

24-Sheet package, 20" x 30"

NUMBER	EACH	10/EA	20/EA
A11306-1013	\$2.30	\$2.07	\$1.97

Spectra® Art Tissue™ Assortments

20-Sheet Package, 20" x 30" — A rainbow assortment of 20 colors.

NUMBER	EACH	10/EA	20/EA
A11306-1009	\$3.88	\$3.49	\$3.32

100-Sheet Package, 20" x 30" — 20-color assortment.

NUMBER	EACH	6/EA	12/EA
A11306-1003	\$13.56	\$12.21	\$11.59

Spectra® Deluxe Bleeding Art Tissue™ Single Sheet Dispenser

This space-saving wire rack holds 40 quires (960 sheets) of 20" x 30" tissue. It easily dispenses one sheet or many sheets at a time.

NUMBER	EACH	3/EA
A12898-1040	\$276.66	\$248.99

Spectra Art Tissue Refill — 40 quires (960 sheets) in 26 assorted colors.

NUMBER	EACH	3/EA
A11306-1040	\$193.41	\$174.07



KolorFast® Tissue

A versatile tissue paper in an array of non-bleeding colors for general purpose needs for pre-school and elementary art projects. 20" x 30" sheets. Choose 10-sheet or 50-sheet assorted packs.

NUMBER	DESCRIPTION	EACH	12/EA	24/EA
A11306-1103	10-Sheet	\$4.49	\$4.04	\$3.84
A11306-1503	50-Sheet	14.99	13.49	12.81



KolorFast® Tissue Flower Kits

Create beautiful, brightly colored 10" tissue flowers. Simply unfold tissue, attach stems, primp tissue, and create a ready-made bouquet, centerpiece, party decoration, or prom keepsake. Includes instructions, pre-cut tissue, and wire stems.

NUMBER	DESCRIPTION	EACH	6/EA	12/EA
A11306-0009	7 Flower Kit	\$8.99	\$8.11	\$7.70
A11306-0019	84 Flower Kit	60.86	54.78	52.04



Lia Griffith™ Crepe Paper

Create exquisite handcrafts with high-quality crepe papers inspired by DIY designer Lia Griffith. These papers can be curled, twisted, and cut into stunning crafts that last a lifetime. Extra Fine is a beautiful, lightweight crepe paper that stretches to 130% of its size, making it extremely malleable and easy to use — also available as double-sided! Heavy is great for making flowers and floral designs such as wreaths, bouquets, and jumbo flowers that stand on their own. Made in Germany. For more weights and colors, visit DickBlick.com.



Spectra® Deluxe Bleeding Art Tissue™

This brilliant tissue makes a great choice for many craft and decorative uses. Will bleed when moistened. Cuts, crinkles, or folds without tearing. Two 20" x 30" sheets each of 10 colors: Cerise, Orange, French Blue, Apple Green, Yellow, Pansy, Medium Blue, Leaf Green, Cadmium Yellow, and Red. 20 sheets.

NUMBER	EACH	12/EA	24/EA
A11306-1029	\$4.44	\$3.99	\$3.81

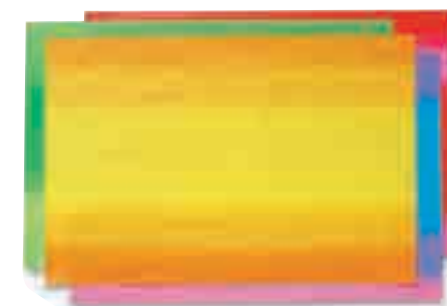

Spectra® Deluxe Bleeding Art Tissue™ Madras Pattern

Reminiscent of the popular "bleeding Madras" fabrics of the 1960s, the colors in these patterned papers blend together when moistened. Each 12" x 18" sheet is striped with two or more complementary colors, and each package contains five different color combinations — 50 sheets in all!

NUMBER	EACH	6/EA	12/EA
A11306-1006	\$9.88	\$8.55	\$8.13

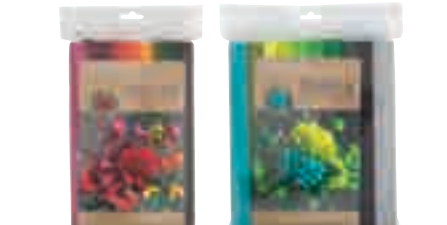

Extra Fine, 2-Sheet Packs, Double Sided — 9.84" x 49.21"

NUMBER	COLOR	EACH	12/EA
A11328-3712	Blush	\$6.74	\$6.06
A11328-3452	Cherry	6.74	6.06
A11328-3242	Coral	6.74	6.06
A11328-7012	Green	6.74	6.06
A11328-1002	Strawberry	6.74	6.06
A11328-1001	White	6.74	6.06

Extra Fine, Rolls — 19.6" x 78.7"

NUMBER	DESCRIPTION	EACH	12/EA
A11328-1003	Metallic Colors, Set of 3 Rolls	\$21.29	\$19.17
A11328-1004	Enchanted Garden, Set of 10 Rolls	15.30	13.78
A11328-1010	Floral Colors, Set of 10 Rolls	21.29	19.17

Heavy, Roll — 9.8" x 39.3"

NUMBER	DESCRIPTION	EACH	12/EA
A11328-1005	Botanical Garden	\$22.40	\$20.16



Creative Washi Pack

Stronger and more durable than most papers, washi is a great choice for crafts, collage, scrapbooking, book making, card making — even to use as a standalone design element. This 1 lb package includes solid and patterned Japanese washi papers in a variety of sizes.

NUMBER	EACH	12/EA	24/EA
A11325-1001	\$24.45	\$21.99	\$20.90



Roylco® Tissue Circles

Perfect pre-cut tissue circles in a spectrum of colors! Roylco Tissue Circles are a must-have for making flowers, snowflakes, and 3-D art. They can also be added to collages, decoupage, and posters. The package contains 480, 4" diameter tissue circles.

NUMBER	EACH	12/EA	24/EA
A11301-1004	\$9.99	\$8.99	\$8.56



Lia Griffith™ Tissue Paper

These multi-sheet packs are great for wedding and party decorations, kid's craft projects, do-it-yourself paper crafts of all kinds — even elegant gift wrapping. Packs of 20" x 20" sheets.

Americana — 25-sheets, five each of Gold Stripe, Gold Star, Scarlet, White, and Blue.

NUMBER	EACH	12/EA
A11326-1001	\$6.99	\$6.29

Fresh Breeze — 24-sheets, four each of Aquamarine, Caribbean Blue, Turquoise, Teal, Cool Mint, and Willow.

NUMBER	EACH	12/EA
A11326-1002	\$12.20	\$10.99

Tropical Squeeze — 24-sheets, four each of Pineapple, Papaya, Mango, Guava, Prickly Pear, and Watermelon.

NUMBER	EACH	12/EA
A11326-1003	\$12.20	\$10.99

Summer Meadow — 24-sheets, four each of Evergreen, Moss, Fern, Grassland, Grasshopper, and Buttercup.

NUMBER	EACH	12/EA
A11326-1004	\$12.20	\$10.99

Corobuff® Corrugated Sheets and Rolls

This brightly colored, fade-resistant corrugated paper is rigid on the width and flexible on the length. It will add texture and dimension to decorating projects, parade floats, paper sculpture, displays, and bulletin boards. Color on one side, white on back. **Colors can be assorted for quantity pricing.**

NUMBER	COLOR	EACH	6/EA	12/EA
A11214-5948	Azure Blue	\$46.75	\$42.12	\$39.99
A11214-2048	Black	46.75	42.12	39.99
A11214-5448	Brite Blue	46.75	42.12	39.99
A11214-4248	Canary Ylw	46.75	42.12	39.99
A11214-7048	Emerald	46.75	42.12	39.99
A11214-3548	Flame Red	46.75	42.12	39.99
A11214-4548	Orange	46.75	42.12	39.99
A11214-1048	White	46.75	42.12	39.99

Corrugated Project Sheets — These 12" x 16" sheets of colored corrugated paper are just right for art and craft projects. 12-sheet package of assorted colors.

NUMBER	EACH	12/EA	24/EA
A11214-1009	\$7.93	\$7.55	\$6.80

Seamless Background Paper

For photography backgrounds, scenery, murals, and displays.

This extra-heavy, tear-resistant poster paper has a non-glare matte finish that takes tempera, watercolor, acrylic, crayon, marker, or chalk. 36 ft long rolls. **Colors can be assorted by size for quantity pricing.**

COLOR	107" WIDE	EACH	3/EA	6/EA	53" WIDE	EACH	3/EA	6/EA
Arctic White	A11601-1137	\$77.80	\$69.99	\$66.48	A11601-1135	\$49.54	\$44.57	\$42.35
Beige	A11601-8136	77.80	69.99	66.48	A11601-8236	49.54	44.57	42.35
Carnation Pink	A11601-3236	77.80	69.99	66.48	A11601-3336	49.54	44.57	42.35
Dawn Gray	A11601-2136	77.80	69.99	66.48	A11601-2236	49.54	44.57	42.35
Deep Blue	A11601-5336	77.80	69.99	66.48	A11601-5436	49.54	44.57	42.35
Forsythia Yellow	A11601-4136	77.80	69.99	66.48	A11601-4236	49.54	44.57	42.35
Ivory	A11601-1336	77.80	69.99	66.48	A11601-1436	49.54	44.57	42.35
Jet Black	A11601-2237	77.80	69.99	66.48	A11601-2336	49.54	44.57	42.35
Mardi Gras	A11601-5937	77.80	69.99	66.48	A11601-5935	49.54	44.57	42.35
Marine Blue	A11601-5536	77.80	69.99	66.48	A11601-5636	49.54	44.57	42.35
Mint Green	A11601-7536	77.80	69.99	66.48	A11601-7636	49.54	44.57	42.35
Nassau	A11601-1017	77.80	69.99	66.48	A11601-1015	49.54	44.57	42.35
Neutral Gray	A11601-2337	77.80	69.99	66.48	A11601-2436	49.54	44.57	42.35
Pursuit Gray	A11601-2437	77.80	69.99	66.48	A11601-2536	49.54	44.57	42.35
Royal Blue	A11601-5057	77.80	69.99	66.48	A11601-5055	49.54	44.57	42.35
Scarlet	A11601-3036	77.80	69.99	66.48	A11601-3136	49.54	44.57	42.35
Sky Blue	A11601-5036	77.80	69.99	66.48	A11601-5136	49.54	44.57	42.35
Slate Gray	A11601-2607	77.80	69.99	66.48	A11601-2605	49.54	44.57	42.35
Snow White	A11601-1136	63.53	57.16	54.29	A11601-1236	49.54	44.57	42.35
Stinger Green	A11601-7027	77.80	69.99	66.48	A11601-7025	49.54	44.57	42.35

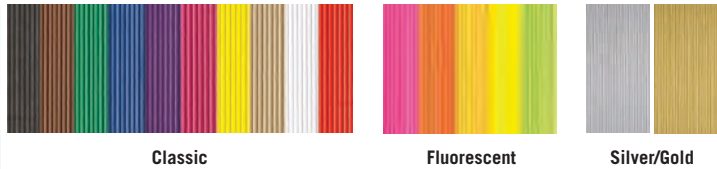

Folia® Corrugated Sheets

Flexible yet sturdy corrugated paper is ideal for collages, backgrounds, and more. Colored on both sides, one side corrugated and one side smooth. 10-sheet packs. Four different assortments. 9-3/4" x 13-3/4". **Colors can be assorted for quantity pricing.**

NUMBER	DESCRIPTION	EACH	6/EA	12/EA
A12231-1010	Classic	\$16.03	\$14.43	\$13.71
A12231-1020	Fluorescent	17.53	15.78	14.99
A12231-1030	Gold/Silver	17.53	15.78	14.99
A12231-1040	Rainbow	16.38	14.74	13.99

Savage Widetone® Background Paper

Widetone is a high-quality, seamless, non-reflecting background paper with an exquisite, fine-tooth feel that belies its affordable price. Manufactured in Savage's on-site plant, Widetone is core-wound and packaged in a plastic sleeve. Hands down the most cost-effective solution for creating smooth, even backgrounds for portraits and photographs, Widetone is also a top choice for theater productions, special event decorations, banners, posters, and even video projection screens. Available in two sizes and a wide variety of colors. For additional colors, visit DickBlick.com. 12 yd long rolls. FOB Factory. See page 648 for details. **Colors can be assorted for quantity pricing.**

COLOR	107" WIDE	86" WIDE	53" WIDE
Black	AF11609-2022	AF11609-2020	AF11609-2021
Bluemist	AF11609-5922	AF11609-5920	AF11609-5921
Blue Jay	AF11609-5062	AF11609-4010	AF11609-4011
Blue Jean	AF11609-5842	AF11609-5840	AF11609-5841
Canary	AF11609-4292	AF11609-4260	AF11609-2141
Chestnut	AF11609-8182	AF11609-8180	AF11609-5021
Crimson	AF11609-3192	AF11609-3160	AF11609-3021
Fashion Gray	AF11609-2152	AF11609-2500	AF11609-2151
Focus Gray	AF11609-2502	AF11609-2150	AF11609-2501
Gray Tint	AF11609-2512	AF11609-2510	AF11609-2511
Primary Red	AF11609-3022	AF11609-3740	AF11609-2111
Smoke Gray	AF11609-2132	AF11609-2130	AF11609-5061
Super White	AF11609-1692	AF11609-1690	AF11609-1691
Tech Green	AF11609-7012	AF11609-7000	AF11609-2091
Tulip	AF11609-4012	AF11609-7010	AF11609-7011
TV Gray	AF11609-2522	AF11609-2530	AF11609-2521
White	AF11609-1012	AF11609-1010	AF11609-1011
	EACH \$85.47	EACH \$78.70	EACH \$53.74
	3/EA 76.92	3/EA 70.83	3/EA 48.36
	6/EA 73.08	6/EA 67.28	6/EA 45.94



Bordette® Scalloped Borders

Made from corrugated paper, Bordette Scalloped Borders are ready to use for bulletin board trim and other classroom decorations. Fade-resistant. 2-1/4"W x 50 ft rolls. **Colors can be assorted for quantity pricing.**

NUMBER	COLOR	EACH	12/EA
A11211-7171	Apple Green	\$3.47	\$3.12
A11211-5911	Azure Blue	3.47	3.12
A11211-2001	Black	3.47	3.12
A11211-8001	Brown	3.47	3.12
A11211-4261	Canary Yellow	3.47	3.12
A11211-6121	Deep Purple	3.47	3.12
A11211-7051	Emerald	3.47	3.12
A11211-3571	Flame Red	3.47	3.12
A11211-7232	Lime	3.47	3.12
A11211-7321	Nile Green	3.47	3.12
A11211-4501	Orange	3.47	3.12
A11211-3051	Pink	3.47	3.12
A11211-5341	Rich Blue	3.47	3.12
A11211-9012	Sunset Gold	3.47	3.12
A11211-6191	Violet	3.47	3.12
A11211-1001	White	3.47	3.12

NUMBER	COLOR	EACH	12/EA
A11211-9025	Gold	\$8.42	\$7.57
A11211-2405	Silver	8.42	7.57

Assorted 6-Color Pack — One each of Black, Canary, Flame Red, Orange, Nile Green, and Royal Blue.

NUMBER	EACH	6/EA
A11211-1009	\$25.04	\$22.51



Hygloss™ Metallic Foil Paper

Wrinkle-Resistant!

Tough and pliable paper-backed foil is ideal for decorating, art projects, paper sculpture, and gift wrap. Brilliant, metallic colors on one side only. **Colors can be assorted for quantity pricing.**

NUMBER	COLOR	EACH	6/EA	12/EA
A11205-5026	Dark Blue	\$18.93	\$17.04	\$16.20
A11205-6026	Fuchsia	18.93	17.04	16.20
A11205-4026	Gold	18.93	17.04	16.20
A11205-7026	Green	18.93	17.04	16.20
A11205-5036	Light Blue	18.93	17.04	16.20
A11205-3036	Pink	18.93	17.04	16.20
A11205-3026	Red	18.93	17.04	16.20
A11205-2526	Silver	18.93	17.04	16.20

Hygloss™ Metallic Foil Packs

Metallic-coated paper on one side, white on the other. 24-sheet packs in assorted colors.

NUMBER	SIZE	EACH	6/EA	12/EA
A11205-1002	8-1/2" x 10"	\$6.95	\$6.26	\$5.95
A11205-1001	20" x 26"	26.08	23.47	22.31

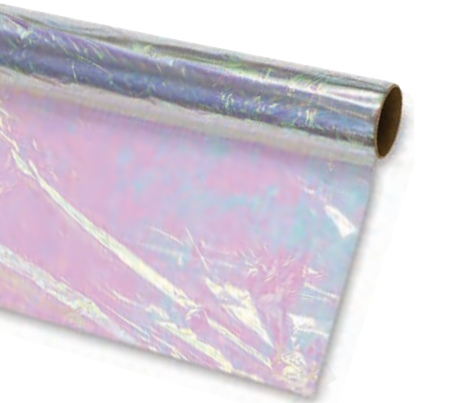

Creativity Street® Iridescent Film

Enhance your holidays and special events by using iridescent film for gifts, gift baskets, and craft projects. Lightweight film wrinkles with ease without ripping and adds soft, illuminating color. 36" x 12-1/2 ft roll.

NUMBER	EACH	12/EA	24/EA
A11209-1036	\$18.35	\$16.50	\$15.65



Hygloss™ Transparent Cellophane

For classroom art projects, displays, and decorations. Moisture-proof, heat-sealable. Rolls are 20" wide, in 25 ft or 100 ft lengths. **Colors can be assorted by size for quantity pricing.**

COLOR	25 FT ROLLS	100 FT ROLLS
Amber	A11219-8130	A11219-8140
Blue	A11219-5025	A11219-5010
Clear	A11219-1925	A11219-1910
Green	A11219-7010	A11219-7020
Red	A11219-3025	A11219-3100
	EACH \$7.80	EACH \$20.03
	6/EA 6.99	6/EA 18.03
	12/EA 6.66	12/EA 17.13

Cello Sheets — Contains 48 Sheets, 12 each of Blue, Green, Red, and Yellow.

NUMBER	SIZE	EACH	6/EA
A12608-1012	12" x 12"	\$8.63	\$7.76



Roylco® Frosted Glass Paper

These bright, beautiful patterns printed on semi-transparent paper are great for creating art with light! The paper is easy for children of all ages to fold. Try a simple sun catcher, create wonderful window art, light up a lantern, or give your origami creations a new look. The pack contains 24, 5-1/2" x 8-1/2" sheets and an idea guide.

NUMBER	EACH	6/EA	12/EA
A12612-1024	\$10.37	\$9.34	\$8.87

Col-R-Tone™ System Masking Tape v Class Pack

This class pack offers 24 distinctly colored, self-adhesive, plasticized paper tapes. Write on them with pen or felt tip marker — their vibrant colors won't fade. Great for use in murals and sculptures. Semi-permanent and repositionable. Each roll is 3/4"W x 500"L.

NUMBER	EACH	3/EA	6/EA
A24122-1024	\$129.34	\$116.40	\$110.58



Crepe Paper

Flame-resistant, superior quality — the most popular crepe paper for a wide variety of decorating and craft uses. Twelve brilliant colors in streamers and 20" folds. Free color chart is available upon request. **Colors can be assorted for quantity pricing.**

Streamers — 1-7/8"W x 500 ft rolls.

NUMBER	COLOR	EACH	6/EA	12/EA
A11208-2001	Black	\$5.11	\$4.58	\$4.35
A11208-4511	Bright Orange	5.11	4.58	4.35
A11208-4081	Buttercup	5.11	4.58	4.35
A11208-3571	Flame Red	5.11	4.58	4.35
A11208-4191	Goldenrod	5.11	4.58	4.35
A11208-7091	Holiday Green	5.11	4.58	4.35
A11208-3461	Holiday Red	5.11	4.58	4.35
A11208-3291	Hot Pink	5.11	4.58	4.35
A11208-5561	Ice Blue	5.11	4.58	4.35
A11208-5801	Midnight Blue	5.11	4.58	4.35
A11208-3051	Pink	5.11	4.58	4.35
A11208-1001	White	5.11	4.58	4.35

Folds — 20"W x 7-1/2 ft long.

NUMBER	COLOR	EACH	6/EA	12/EA
A11208-2006	Black	\$1.48	\$1.33	\$1.27
A11208-4516	Bright Orange	1.48	1.33	1.27
A11208-8006	Brown	1.48	1.33	1.27
A11208-3576	Flame Red	1.48	1.33	1.27
A11208-7096	Holiday Green	1.48	1.33	1.27
A11208-3466	Holiday Red	1.48	1.33	1.27
A11208-3296	Hot Pink	1.48	1.33	1.27
A11208-6186	Royal Purple	1.48	1.33	1.27
A11208-5296	Sapphire Blue	1.48	1.33	1.27
A11208-1006	White	1.48	1.33	1.27



Fadeless® Art Paper

This fade-resistant, 50 lb (74 gsm) art paper has a smooth, matte finish color on one side, white on the other side. Excellent for paper sculpture, bulletin board work, signs, posters, and backgrounds. 24" rolls come in a dispenser box.

Colors can be assorted by size for quantity pricing.

COLOR	24" WIDE X 60 FT	48" WIDE X 50 FT
Apple Green	A12915-7174	A12915-7178
Azure	A12915-5924	A12915-5928
Black	A12915-2024	A12915-2048
Brite Blue	A12915-5444	A12915-5448
Brite Purple	—	A12915-6018
Burgundy	—	A12915-3148
Canary	A12915-4224	A12915-4248
Dark Yellow	A12915-4004	A12915-4008
Deep Brown	A12915-8824	A12915-8848
Deep Purple	—	A12915-6058
Emerald	A12915-7024	A12915-7048
Flame Red	A12915-3524	A12915-3548
Lime	—	A12915-7238
Lite Blue	A12915-5024	A12915-5028
Magenta	—	A12915-3028
Nile Green	A12915-7324	A12915-7328
Orange	A12915-4524	A12915-4548
Pink	A12915-3124	A12915-3128
Royal Blue	A12915-5074	A12915-5078
Sunset Gold	—	A12915-9118
Violet	A12915-6124	A12915-6128
White	A12915-1024	A12915-1048
	EACH \$16.51	EACH \$21.86
	6/EA 14.84	6/EA 19.65
	12/EA 14.10	12/EA 18.67

Fadeless® Art Paper Assortments

The same great paper, in themed assortments of four 48" x 12 ft rolls. 50 lb (74 gsm).

Neutrals — One roll each of Black, White, Pewter, and Tan.

NUMBER	EACH	6/EA
A12915-1010	\$40.72	\$36.64

Primaries — One roll each of Flame, Royal Blue, Canary, and Apple Green.

NUMBER	EACH	6/EA
A12915-1011	\$40.72	\$36.64

Brights — One roll each of Lime, Deep Purple, Magenta, and Azure.

NUMBER	EACH	6/EA
A12915-1012	\$40.72	\$36.64

12" x 18" Sheets

NUMBER	DESCRIPTION	EACH	12/EA
A12884-1006	20-Sheets	\$6.96	\$6.19
A12915-1006	60-Sheets	11.41	10.59

18" x 24" Sheets

NUMBER	DESCRIPTION	EACH	12/EA
A12884-1009	60-Sheets	\$25.89	\$23.04



Paper Remnants Value Pack

More than 8 lb of paper in a pack that offers variety and exceptional value. Includes a fantastic selection of colorful paper scraps, shapes, and more.

NUMBER	EACH	6/EA
A11320-1008	\$25.98	\$23.39



Fadeless® Safari Prints

Experience the next level of realistic animal skin patterns. Giraffes, tigers, zebras — the whole menagerie. These prints are created using Fadeless Ink technology. The animal skin patterns will remain vibrant. Also for crafts and scrapbooking.

6-Roll Sampler — Contains six rolls of paper, 24" x 8 ft; one each of giraffe, tiger, zebra, cheetah, alligator, and snake.

NUMBER	EACH	6/EA	12/EA
A12852-1006	\$38.13	\$34.32	\$32.62

12" x 18" 24-Sheet Pack

NUMBER	EACH	6/EA	12/EA
A12852-1018	\$11.12	\$10.03	\$9.51



Fadeless® Metallic Paper

Brightly colored paper with a metallic pearlescent finish that can be used for backgrounds, displays, banners, gifts, and much more.

12" x 18" Sheets — Package of 24 sheets. Contains four sheets each of the following colors: Gold, Silver, Magenta, Green, Blue, and Red.

NUMBER	EACH	12/EA	24/EA
A11215-1006	\$11.62	\$10.46	\$9.93



Fadeless® Designer Art Paper

Still the premier, ultra fade-resistant, acid-free display paper for school, home, office. Vibrant value pack includes four sheets each of 25 standard, metallic, and contemporary colors (100 sheets per pack). 12" x 18".

NUMBER	EACH	6/EA	12/EA
A12883-1006	\$23.49	\$21.99	\$20.91



Premium Glossy Fadeless® Rolls

The perfect background for accents and decorations, these rolls contain heavyweight paper in six popular, brilliant colors. Fade-resistant and acid-free, it's ideal for paper sculpture, bulletin board work, signs, posters, and more. 48" x 12 ft roll. Colors can be assorted for quantity pricing.

NUMBER	COLOR	EACH	6/EA	12/EA
A12776-5910	Cosmic Blue	\$8.91	\$7.99	\$7.61
A12776-7230	Festive Green	8.91	7.99	7.61
A12776-3412	Festive Red	8.91	7.99	7.61
A12776-7920	Glorious Green	8.91	7.99	7.61
A12776-2280	Jet Black	8.91	7.99	7.61
A12776-5040	Nautical Navy	8.91	7.99	7.61
A12776-4510	Outrageous Orange	8.91	7.99	7.61
A12776-1020	Porcelain White	8.91	7.99	7.61
A12776-3060	Rocker Magenta	8.91	7.99	7.61
A12776-4910	Sassy Yellow	8.91	7.99	7.61



Fadeless® 2-Color Duet Paper

Both sides are ink-coated with a different but coordinating fade-resistant color. Ideal for origami, negative/positive designs, silhouettes, and more. Assorted colors. 30-sheet package, 12" x 18".

NUMBER	EACH	12/EA
A12908-1006	\$12.16	\$10.92



Roylco® Rainbow Paper

Children of all ages are fascinated by rainbows when they occur in nature. Bring that fascination into the classroom with this dynamic paper in eight different rainbow designs. Make paper chains, animals, and other crafts, or encourage creative writing by asking students to write poems about natural phenomena using rainbow paper as a backdrop. Pack includes 96, 8-1/2" x 11" sheets, and a guide.

NUMBER	EACH	12/EA
A11331-1002	\$20.40	\$18.54

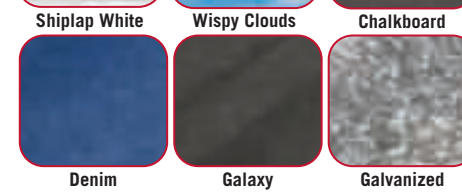

Fadeless® Design Rolls

Designs work great for backgrounds, displays, table skirting, and party decorations. Made with fade-resistant inks for long-lasting displays and bulletin boards. Acid-free and recyclable. 48" x 50".

NUMBER	DESCRIPTION	EACH	4/EA
A12743-1110	Black and White Dots	\$27.05	\$24.36
A12743-2185	City Lights	27.05	24.36
A12743-1015	Clouds	27.05	24.36
A12743-1007	Denim	27.05	24.36
A12743-4015	Flagstone	27.05	24.36
A12743-1003	Galaxy	27.05	24.36
A12743-1006	Galvanized	27.05	24.36
A12743-1106	Gears	27.05	24.36
A12743-4105	Natural Burlap	27.05	24.36
A12743-2195	Night Sky	27.05	24.36
A12743-2105	Reclaimed Brick	27.05	24.36
A12743-3015	Rockwall	27.05	24.36
A12743-1108	School Doodles	27.05	24.36
A12743-1004	Shiplap	27.05	24.36
A12743-1107	Shiplap White	27.05	24.36
A12743-2175	Summer Horizon	27.05	24.36
A12743-7115	Tropical Foliage	27.05	24.36
A12743-2015	Tu-Tone™ Brick	27.05	24.36
A12743-7015	Under the Sea	27.05	24.36
A12743-6015	Weathered Wood	27.05	24.36
A12743-9015	Winter Time	27.05	24.36
A12743-1109	Wispy Clouds	27.05	24.36

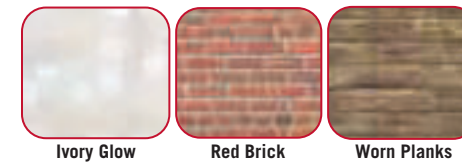
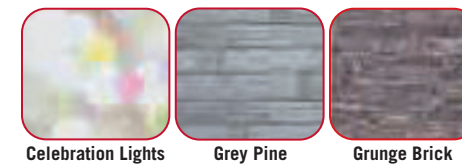

Savage Printed Background Paper

Great for photography sessions, photo booths, celebrations, and more, this high-quality paper is acid-free, lignin-free, and pH-neutral. Conveniently sized at 53" wide x 18 ft long, it's core-wound for easy hanging — simply unroll what you need. It features a continuous pattern that runs the full length of the roll and has a fine-tooth, 163 gsm, non-reflective surface.

NUMBER	DESCRIPTION	EACH	6/EA
A11600-1001	Celebration Lights	\$95.53	\$85.97
A11600-1003	Gray Pine	95.53	85.97
A11600-1002	Grunge Brick	95.53	85.97
A11600-1004	Ivory Glow	95.53	85.97
A11600-1005	Red Brick	95.53	85.97
A11600-1006	Worn Planks	95.53	85.97



Pacon® Card Stock

This heavyweight (65 lb), 8-1/2" x 11" card stock is perfect for greeting cards, postcards, report covers, rubber stamping, memory books, flyers, announcements, and more. Acid-free, lignin-free, and buffered, it can be used with inkjet and laser printers and photocopiers. 100-sheet packs.

NUMBER	COLOR	EACH	6/EA
A11319-2021	Black	\$14.76	\$13.25
A11319-1011	Brights	14.76	13.25
A11319-1211	Hyper	14.76	13.25
A11319-1111	Pastel	14.76	13.25
A11319-1021	White	14.76	13.25



Pacon® UCreate® Neon Art Paper

A 20-sheet package of heavyweight, all-purpose art paper, five sheets each of Neon Yellow, Neon Green, Neon Orange, and Neon Pink. 9" x 12" sheets, all backed with Yellow.

NUMBER	EACH	12/EA	24/EA
A12904-0039	\$6.22	\$5.59	\$5.31

Rainbow® Duo-Finish® Economy Kraft Paper

This 40 lb paper is a great economical alternative to ArtKraft. Designed to be versatile, it has two distinct surfaces, one smooth (ideal for chalk, markers, and pen), and one rough (perfect for wet media such as tempera paints or watercolors). It's a great choice for displays, table covers, crafts, school projects, and more. The Kraft fibers make it easy to cut cleanly, while the durable storage carton dispenses the paper easily and keeps it clean when not in use. Does not qualify for free shipping offer. Colors can be assorted for quantity pricing.

NUMBER	COLOR	EACH	3/EA
A11510-2006	Black	\$80.61	\$72.56
A11510-5016	Blue	101.15	91.04
A11510-5146	Brite Blue	103.73	93.37
A11510-7246	Brite Green	100.10	90.10
A11510-8006	Brown	80.04	72.04
A11510-5036	Dark Blue	78.27	70.45
A11510-3556	Flame	99.45	89.51
A11510-7016	Green	73.33	65.99
A11510-7026	Lite Green	91.36	82.23
A11510-4516	Orange	92.90	83.62
A11510-3066	Pink	86.84	78.16
A11510-6016	Purple	97.69	87.91
A11510-3016	Red	83.85	75.47
A11510-5076	Royal Blue	113.36	101.99
A11510-5096	Sky Blue	93.47	84.13
A11510-1026	White	75.11	67.61
A11510-5006	Yellow	88.29	79.47





ArtKraft® Duo-Finish® Art Paper

ArtKraft's versatility lies in its heavy, 50 lb weight and its two distinct surfaces. The smooth side is ideal for felt markers, finger paint, fine-line drawing, or similar art media where bleed is not desired. Turn it over and a superior tooth surface handles chalk, tempera, watercolors, and acrylics with equal ease. Ideal for bulletin boards, murals, banners, posters, paper sculpture, display backgrounds, table covers, and carnival booths. 48"W x 200 ft rolls or 36"W x 1000 ft rolls. 1000 ft rolls are FOB factory. Colors can be assorted for quantity pricing.

48"W x 200 ft Rolls

NUMBER	COLOR	EACH	3/EA	6/EA
A11506-5248	Aqua	\$44.94	\$40.45	\$38.45
A11506-2078	Autumn Gold	47.35	42.62	40.51
A11506-2048	Black	39.57	35.62	33.86
A11506-5148	Bright Blue	45.16	40.64	38.64
A11506-7248	Bright Green	46.25	41.63	39.57
A11506-4248	Canary Yellow	43.33	38.99	37.08
A11506-5048	Dark Blue	35.90	32.32	30.72
A11506-7048	Emerald Green	35.99	32.39	30.79
A11506-3548	Flame Red	45.16	40.64	38.64
A11506-2228	Gray	50.46	45.41	43.17
A11506-7148	Light Green	43.60	39.24	37.30
A11506-4548	Orange	50.92	45.83	43.57
A11506-3048	Pink	48.84	43.95	41.76
A11506-6048	Purple	45.16	40.64	38.64
A11506-8248	Rich Brown	37.38	33.64	31.98
A11506-3088	Scarlet	48.84	43.95	41.76
A11506-5078	Sky Blue	46.25	41.63	39.57
A11506-1048	White	34.47	30.99	29.47

36"W x 1000 ft Rolls FOB Factory. See page 648 for details.

NUMBER	COLOR	EACH	3/EA	6/EA
AF11509-5026	Aqua	\$128.14	\$119.20	\$113.22
AF11509-2076	Autumn Gold	141.08	131.28	118.15
AF11509-2006	Black	107.48	99.99	94.98
AF11509-5146	Bright Blue	135.19	121.68	115.66
AF11509-7246	Bright Green	146.37	131.74	125.14
AF11509-4256	Canary Yellow	139.35	125.41	119.14
AF11509-5036	Dark Blue	105.86	103.10	97.38
AF11509-7056	Emerald Green	99.17	92.27	87.63
AF11509-3556	Flame Red	154.56	139.10	132.14
AF11509-2226	Gray	129.83	116.84	110.35
AF11509-7026	Light Green	132.41	119.13	113.20
AF11509-4516	Orange	135.39	121.87	115.77
AF11509-3066	Pink	121.27	109.15	103.76
AF11509-6016	Purple	134.04	120.67	114.62
AF11509-8006	Rich Brown	103.99	93.95	88.90
AF11509-5076	Royal Blue	141.39	127.25	120.89
AF11509-3086	Scarlet	129.72	116.75	110.91
AF11509-5086	Sky Blue	131.77	118.59	112.64
AF11509-1026	White	103.79	93.42	88.80

ArtKraft® Rotary Rack Dispenser >

Sturdy gray powder-coated steel rack is filled with 10 rolls of ArtKraft paper of assorted colors, 48"W x 200 ft long. Spring-loaded cutter bar holds paper in place. Now with two additional casters so it moves easily when fully loaded. Weighs 210 lb. Ships unassembled. Truck Shipment and FOB Factory. See page 648 for details.

NUMBER	EACH
AF12938-0100	\$1150.00

Rotary Rack Dispenser Only — Unassembled. Truck Shipment and FOB Factory. See page 648 for details.

NUMBER	EACH
AF12938-0000	\$745.00

Tru-Ray® Art Paper Rolls

Great for banners and art projects. Made of 100% vat-dyed sulphite for superior strength and fade-resistance. 76 lb in 36"W x 500 ft rolls. Does not qualify for free shipping offer. Colors can be assorted for quantity pricing.

NUMBER	COLOR	EACH	3/EA	6/EA
A11504-2001	Black	\$186.38	\$167.75	\$159.34
A11504-5001	Blue	199.27	179.35	170.36
A11504-7001	Festive Green	222.12	199.91	189.90
A11504-3411	Festive Red	189.63	170.67	162.12
A11504-4501	Orange	183.67	165.31	157.03
A11504-5071	Sky Blue	178.15	160.34	152.31
A11504-1001	White	151.94	136.75	129.90
A11504-4001	Yellow	186.38	167.75	159.34

Decolor® Flame Retardant Paper Rolls

This vibrant, flame-retardant paper arrives in convenient 36"W x 1000 ft long rolls for use in all your large projects. The durable 40 lb paper has a surface that accepts all media on either side. It's great for art projects, banners, murals, and bulletin boards. 100% sulphite. Acid-free. This paper conforms to the NFPA No. 701 Standards. Does not qualify for free shipping offer. FOB Factory. See page 648 for details. Colors can be assorted for quantity pricing.

NUMBER	COLOR	EACH	3/EA
AF11518-2050	Black	\$179.09	\$161.20
AF11518-4860	Blue	179.09	161.20
AF11518-8040	Dark Brown	179.09	161.20
AF11518-7230	Festive Green	179.09	161.20
AF11518-3410	Festive Red	179.09	161.20
AF11518-4030	Gold	179.09	161.20
AF11518-4510	Orange	179.09	161.20
AF11518-3060	Pink	179.09	161.20
AF11518-5630	Purple	179.09	161.20
AF11518-5070	Sky Blue	179.09	161.20
AF11518-1040	White	179.09	161.20
AF11518-4020	Yellow	179.09	161.20



Pacon® Natural Kraft Paper

Strong, 40 lb weight, standard brown wrapping paper. Economical art paper for murals, large drawings, posters, and other projects. Choose from 24", 36", or 48"W rolls containing 1000 ft each, or a new 48"W roll containing 200 ft. Does not qualify for free shipping offer.

NUMBER	WIDTH	EACH	3/EA	6/EA
A11503-1024	24"	\$59.23	\$53.31	\$50.64
A11503-8009	36"	77.97	70.17	66.66
A11503-1048	48"	106.32	95.69	90.91

48" x 200 ft Roll

NUMBER	EACH	3/EA	6/EA
A11503-2048	\$33.66	\$30.30	\$28.79

Classroom Keepers® Paper & Roll Storage

Designed to help organize and store paper rolls, posters, and other large materials, this handy storage unit features 16 separate compartments; however, the dividers can be rearranged to create fewer (and larger) compartments. Made from recycled materials, the 12" x 12" square unit measures 24" high.

NUMBER	EACH	12/EA
A77732-1001	\$25.57	\$22.99



A

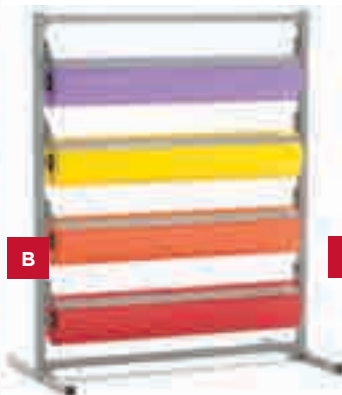

B



C



D



8-Roll Rack



E

1-Roll Rack

8-Roll Rack

F

A Portable Rola-Rack

A deluxe paper rack for 36" wide rolls only. Constructed of welded and formed steel for a lifetime of service. It holds eight rolls, has self-adjusting blade paper cutters, and heavy-duty casters. Overall dimensions: 53"H x 38"W x 25"D. FOB Factory. See page 648 for details.

NUMBER	DESCRIPTION	EACH
AF12910-0100	Unassembled	\$685.00
AF12910-0000	Assembled	965.00

B 4-Roll and 2-Roll Standing Units

Very sturdy, self-standing paper racks are made of steel with welded bases. For paper roll sizes up to 36" wide. Equipped with standard cutting blades. Ship unassembled. FOB Factory. See page 648 for details.

NUMBER	DESCRIPTION	EACH
AF12913-1004	4-Roll Unit	\$330.00
AF12913-1036	2-Roll Unit	202.20

C 8-Roll Vertical Rack

This portable rack is accessible from all sides and occupies less than 5 sq ft of floor space. Holds eight 36" rolls of paper or other rolled materials, up to 9" in diameter. Moves easily on smooth-rolling, heavy-duty casters, equipped with wheel-locking devices. Eight independently mounted, spring-loaded blades facilitate sure, easy dispensing and fast, easy cuts. Heavy-duty welded steel construction with gray, baked-enamel finish. Ships partially assembled; assembly is simple and easy using common tools. Overall dimensions: 46-1/4"H x 25-1/4" square. FOB Factory. See page 648 for details.

NUMBER	EACH
AF12914-1006	\$881.00

D Wall Racks

For wall mounting only. Steel rack holds any size paper roll, up to 36" wide. Ships unassembled. FOB Factory. See page 648 for details.

NUMBER	COLOR	EACH	6/EA
A11520-2023	Black	\$24.24	\$21.82
A11520-9030	White	24.24	21.82

E Vertical Paper Racks

Choose from 1-, 2-, 4-, or 8-roll models. These versatile, easy-to-load, easy-to-move mobile units hold paper rolls from 30" to 36" wide. Each model is equipped with a safe, automatic knife-locking device. Made of 1-1/4" square steel tubing with a gray, baked-enamel finish. 2-, 4-, and 8-roll racks come with casters; 1-roll rack does not. All models are fully assembled. FOB Factory. See page 648 for details.

NUMBER	DESCRIPTION	EACH
AF12909-1000	1-Roll Rack	\$201.77
AF12909-1036	2-Roll Rack	461.00
AF12909-1004	4-Roll Rack	483.00
AF12909-1008	8-Roll Rack	920.00

F Single Roll Cutter

Versatile, all-steel cutter hangs on the wall or stands freely. Choose from three different cutter widths. Each size holds one roll of paper 9" in diameter. Double-edge floating knife of heavy steel stays in the proper cutting position; cannot break or warp. A locking device holds legs firmly. Folds flat for storage.

NUMBER	WIDTH	EACH
A12911-2590	24"	\$53.94
A12911-1036	36"	66.63
A12895-2590	48"	134.44

G White Poster Bond Paper

Super-white, smooth, hard surface is easy to letter, excellent for banners and artwork. 150 ft rolls.

24 lb Weight

NUMBER	WIDTH	EACH	6/EA	12/EA
A11501-1024	24"	\$36.80	\$33.13	\$31.49
A11501-1124	36"	49.08	44.17	41.99
A11501-1224	48"	66.21	59.59	56.65

20 lb Weight

NUMBER	WIDTH	EACH	6/EA	12/EA
A11501-1120	24"	\$29.11	\$26.20	\$24.90
A11501-1220	36"	42.04	37.84	35.97
A11501-1320	48"	53.99	48.61	46.21
A11501-1020	60"	73.08	65.78	62.52

H Pacon® White Kraft Paper

Practical, all-purpose 40 lb weight paper with a dull surface for banners, murals, signs, posters, even table covers. Choose from 24", 36", or 48"W x 9"Dia rolls containing 1000 ft each. Does not qualify for free shipping offer.

NUMBER	WIDTH	EACH	3/EA
A11502-1024	24"	\$53.81	\$48.43
A11502-1009	36"	70.99	63.91
A11502-1048	48"	101.74	91.57

I Art Street® Easel Rolls

Bright white sulphite drawing paper in a convenient dispenser roll. Ideal for both wet and dry media, these easel rolls have a 1" core to fit most standard-size easels. Choose 12" wide roll (100 ft long) or 18" wide rolls (75 ft and 100 ft long).

NUMBER	SIZE	EACH	6/EA
A10251-1012	12" x 100 ft roll	\$12.21	\$10.99
A10251-1018	18" x 100 ft roll	20.39	18.35
A10251-1118	18" x 75 ft roll	8.58	7.72

J Richeson® Butcher Paper

Excellent for craft projects, Richeson butcher paper is a 44 lb paper that can even be used as a bleedproof palette paper. The white paper is ideal for markers, acrylics, gouache, finger paints, and more. The black paper is excellent for fluorescents, iridescents, and glow-in-the-dark paints and markers. 30" x 50 ft rolls.

NUMBER	COLOR	EACH	6/EA
A11520-2023	Black	\$24.24	\$21.82
A11520-9030	White	24.24	21.82

K Pacon® Newsprint Roll

Quality white newsprint with a smooth finish for numerous practice and art applications. Packed in a convenient dispensing and storage box. This is a very practical way to purchase your newsprint. 36"W x 100 ft roll.

NUMBER	EACH	12/EA	24/EA
A10226-1020	\$20.99	\$18.92	\$17.96



Pacon® Railroad Board

A smooth, bristol-type board, coated on both sides with bright colors or white. Use for signs, posters, mailing cards, tickets, tags, and more. 22" x 28" sheets. **Colors can be assorted for quantity pricing.**

COLOR	6-PLY (.20")	4-PLY (.014")
Black	A13105-2102	A13105-2002
Brown	A13105-8002	A13105-8012
Dark Blue	A13105-5152	A13105-5052
Holiday Green	A13105-7462	A13105-7362
Lemon Yellow	A13105-4162	A13105-4062
Light Blue	A13105-5922	A13105-5912
Magenta	A13105-3142	A13105-3042
Orange	A13105-4602	A13105-4502
Pink	A13105-1192	A13105-1092
Purple	A13105-6022	A13105-6012
Red	A13105-3102	
EACH	\$1.04	\$.91
25/EA	.94	.82

22" x 28" White — 6-ply (.22").

NUMBER	EACH	25/EA
A13105-1102	\$.99	\$.90

22" x 28" Sheet Assortment				
NUMBER	SHEETS	PLY	EACH	10/EA
A13105-0429	25	4	\$18.05	\$16.23
A13105-0629	25	6	23.89	21.50

11" x 14" Sheet Assortment				
NUMBER	SHEETS	PLY	EACH	10/EA
A13105-0459	50	4	\$10.03	\$8.99
A13105-0659	50	6	12.04	10.84

**All-Purpose Chipboard**

The smooth, uncoated surface of this all-purpose chipboard is ideal for mounting, backing, constructing, bookmaking, and more. Made from recycled paper; color may vary.

Double Thick (.100") — Approximately 30-ply.

NUMBER	SIZE	EACH	25/EA
A13115-2232	22" x 28"	\$2.35	\$2.11
A13115-2236	28" x 44"	4.44	3.99

Single Thick (.050") — Approximately 14-ply.

NUMBER	SIZE	EACH	25/EA
A13115-2222	22" x 28"	\$1.08	\$.97
A13115-2226	28" x 44"	1.98	1.78

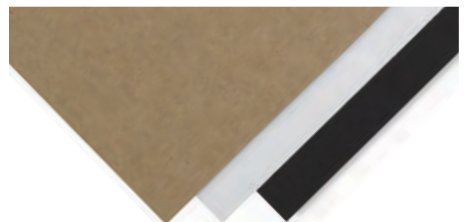
**Grafix® Chipboard**

This medium-weight chipboard is sturdy enough to be painted, stamped, and sanded, yet thin enough to be cut by many die-cut machines. Pack of 15, 8-1/2" x 11" sheets contains five each of Black, White, and Natural.

NUMBER	EACH	6/EA
A13141-1011	\$6.60	\$5.94

**Pacon® UCreate® Chalkboard Poster Board**

This coated black poster board performs just like a chalkboard! A great background for both white and colored chalk, it has a reusable surface that can be wiped clean to create a worn look, then reused. Acid-free and fade-resistant, this durable 18 pt board is ideal for signs, posters, photo boards, and more. 22" x 28" sheets.

NUMBER	EACH	25/EA
A13154-1002	\$2.49	\$2.25

**Pacon® Super Value Poster Board**

An attractive price per sheet makes this poster board an economical choice. Reclosable carton makes storage and dispensing easy. 50-sheet packs of 22" x 28" sheets. Colored Pack includes 10 each of Black, Blue, Green, Red, and Yellow. Recyclable.

NUMBER	COLOR	EACH	6/EA	12/EA
A13100-1022	White	\$26.65	\$23.94	\$22.74
A13100-1028	Colored	33.90	30.50	28.98

**Pacon® UCreate® Neon Poster Board**

Neon Poster Board is a truly rigid 12-pt board that accepts all dry and wet media. It has a smooth, hard finish and features vivid, fade-resistant color on both sides. The 25-sheet assortment includes five 22" x 28" sheets each of Hot Red, Hot Pink, Hot Orange, Hot Lemon, and Hot Lime.

NUMBER	EACH	12/EA
A13151-1002	\$29.93	\$26.93

Blick® Deluxe White Posterboard

Fine-quality, clay-coated paper stock with a very smooth, non-glare, matte finish laminated to a sturdy gray chipboard. The surface is excellent for oil-based or waterbased paints and inks, permanent markers, watercolor markers, pencil, and crayon.

14-Ply Deluxe Posterboard, White Both Sides

NUMBER	SIZE	EACH	25/EA
A13104-1002	22" x 28"	\$2.69	\$2.42
A13104-1006	28" x 44"	6.99	6.29

14-Ply Deluxe Posterboard, White One Side

NUMBER	SIZE	EACH	25/EA
A13104-1102	22" x 28"	\$3.59	\$3.23

Blick® Economy White Posterboard

For all kinds of signs and posters — especially good for school use!

5-Ply Economy Posterboard, White One Side

NUMBER	SIZE	EACH	25/EA
A13109-1102	22" x 28"	\$.92	\$.83

6-Ply Economy Posterboard, White Both Sides

NUMBER	SIZE	EACH	25/EA
A13109-1202	22" x 28"	\$1.47	\$1.33
A13109-1106	28" x 44"	3.50	3.15

8-Ply Economy Posterboard, White One Side

NUMBER	SIZE	EACH	25/EA
A13109-1302	22" x 28"	\$.76	\$.68
A13109-1206	28" x 44"	1.49	1.35

Pacon® UCreate® Plastic Poster Board

Waterproof, tear-resistant, durable, and flexible, Pacon Plastic Poster Board accepts most art media, including dry erase markers. Cut it, make stencils, use it for school projects such as multi-color collages and 3-D artworks.

Made from a 12 pt, lead-free polyethylene material. 22" x 28" sheets. **Colors can be assorted for quantity pricing.**

NUMBER	COLOR	EACH	25/EA
A13155-5912	Azure	\$3.25	\$2.91
A13155-2022	Black	3.25	2.91
A13155-1602	Clear	3.25	2.91
A13155-7272	Fluorescent Green	3.25	2.91
A13155-3722	Fluorescent Pink	3.25	2.91
A13155-3012	Red	3.25	2.91
A13155-1022	White	3.25	2.91
A13155-4012	Yellow	3.25	2.91

**Flipside Corrugated Sheets**

Lightweight, sturdy, and economical, these 20" x 30" corrugated sheets are great for art projects and displays. They measure 3/16" thick, with a color on one side. **Colors can be assorted for quantity pricing.**

NUMBER	COLOR	EACH	25/EA
A13142-2003	Black	\$2.65	\$2.39
A13142-5013	Blue	2.65	2.39
A13142-7023	Green	2.65	2.39
A13142-4513	Orange	2.65	2.39
A13142-3063	Pink	2.65	2.39
A13142-6013	Purple	2.65	2.39
A13142-3013	Red	2.65	2.39
A13142-5093	Sky Blue	2.65	2.39
A13142-1023	White	2.44	2.19
A13142-4013	Yellow	2.65	2.39

Hygloss™ Mirror Boards

Add elegance and shine to your crafts, decorations, and signs with these ultra-shiny, highly reflective mirror boards. Featuring a metallic surface on one side and a white cardstock surface on the other, these sturdy 12-pt boards can easily be cut with scissors. Six brilliant colors.

8-1/2" x 11" — 10 sheets.

NUMBER	COLOR	EACH	3/EA
A12486-4861	Blue	\$10.99	\$9.91
A12486-9501	Copper	10.99	9.91
A12486-9011	Gold	10.99	9.91
A12486-7031	Green	10.99	9.91
A12486-2981	Red	10.99	9.91
A12486-9331	Silver	10.99	9.91

5" x 7" Silver — 25 sheets.

NUMBER	EACH	3/EA
A12486-9330	\$8.16	\$7.35

5" Circles — 25 each

NUMBER	EACH	3/EA
A12486-1025	\$6.32	\$5.69

**Pacon® Natural Kraft Poster Board**

This sturdy 18 pt posterboard is made from 100% recycled fiber and 85% post-consumer materials. Its natural kraft finish on both sides is ideal for signs, 3-D projects, and crafts of all kinds. Use it for shabby chic home décor projects, or any application with a nature or environmental theme. 22" x 28" sheet.

NUMBER	EACH	25/EA
A13157-1002	\$.99	\$.91

**Ucreate™ Poster Board**

This big poster board has a shimmering black and gold foil chevron border design that complements your artwork, signs, decorations, and more. The 22" x 28" size means there's lots of room for decorating or embellishing the white space with different media.

NUMBER	DESCRIPTION	EACH	25/EA
A13156-2912	Black and Gold Chevron	\$2.39	\$2.15

When ordering sheets of paper or board larger than 18" x 24", a handling fee may apply. See page 648.

2-Ply Tag Board

Extra-heavy (150 lb) index bristol has a smooth surface for pencil, pen, marker, crayon, and more. An ideal material for postcards, posters, program covers, and paper sculpture.

Manila — 100-sheet packages.

NUMBER	SIZE	EACH	6/EA
A13111-1103	9" x 12"	\$6.92	\$6.23
A13111-1107	12" x 18"	14.79	13.31
A13111-1109	18" x 24"	32.08	28.86
A13111-1105	24" x 36"	45.62	41.06

White — 100-sheet packages.

NUMBER	SIZE	EACH	6/EA
A13111-1003	9" x 12"	\$6.92	\$6.23
A13111-1007	12" x 18"	14.79	13.31
A13111-1009	18" x 24"	32.08	28.86
A13111-1005	24" x 36"	45.62	41.06

**Hygloss™ Bright Tag**

This 65 lb tag is heavier than construction paper, lighter than Railroad Board, and perfect for making cards, posters, covers, and for screen printing. Use it with copy machines or laser printers. Made from 20% post-consumer recycled materials. Acid-free and fade-resistant, with 12 assorted, brilliant colors per package.

8-1/2" x 11" Sheets — Package of 96 sheets.

NUMBER	EACH	6/EA
A13103-1098	\$17.80	\$16.03

11" x 17" Sheets — Package of 48 sheets.

NUMBER	EACH	6/EA
A13103-1009	\$17.80	\$16.03

**Crescent® Not Foam™ Corrugated Cardboard**

This cardboard sheet has a buffered, acid-free, smooth white surface and a natural kraft corrugation and backing. It earned its name by being "not foam," i.e., recyclable, renewable, and composable. Not Foam is composed of E and B corrugated fluting and measures 3/16" (4.76 mm) thick. It accepts markers, tempera paints, and acrylic paints. 32" x 40" sheet.

NUMBER	EACH	12/EA
A13903-1026	\$5.50	\$4.95

**Utrecht Chipboard**

This economical uncoated cardboard is made from 100% recycled paper (90% post-consumer content). Designed for architectural model making, it has smooth edges and is available in six thicknesses and two sizes.

29" x 46" — Brown

NUMBER	DESCRIPTION	EACH	25/EA
A13145-3146	0.031" Thick	\$2.53	\$2.28
A13145-6246	0.062" Thick	4.40	3.96

30" x 40" Sheets — Brown

NUMBER	DESCRIPTION	EACH	25/EA
A13145-1230	0.120" Thick	\$9.72	\$8.75
A13145-4030	0.04" Thick	2.53	2.28
A13145-8030	0.08" Thick	6.28	5.65

30" x 40" Sheets — White

NUMBER	DESCRIPTION	EACH	25/EA
A13145-2340	0.02" Thick	\$2.04	\$1.83

**< Vertical/Horizontal Board Rack**

Use this versatile wire rack as space demands — vertically or horizontally — to store more than 300 sheets of 22" x 28" board. Ideal, economical storage for stores, studios, or classrooms. White.

NUMBER	EACH	6/EA
A12899-1042	\$182.67	\$164.40

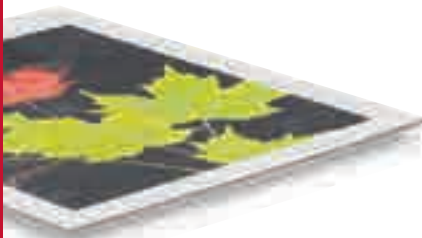

Elmer's® White Heat-Activated Foam Board

Now there's an easier, single-step way to mount posters, prints, or any porous material — no measuring, cutting, or tacking needed. The heat and pressure from a 180°F dry-mount press activates the adhesive coating on the foam board, forming a smooth, permanent bond. Interleaved with protective paper sheets. 3/16" thick. Package of 25 sheets.

NUMBER	SIZE	EACH	3/EA	6/EA
A13210-1015	24" x 36"	\$188.76	\$169.88	\$161.39
A13210-1006	32" x 40"	280.29	252.26	239.65



Elmer's® Tri-Fold Project Board

Designed for stand-alone tabletop presentations for art and science fair projects, business displays, and temporary signage. Made of white surface corrugated cardboard in two popular sizes. 40" x 28" folded size, 36" x 48" open size.

NUMBER	SIZE	EACH	24/EA	48/EA
A13101-1006	40" x 28"	\$5.45	\$4.89	\$4.64
A13101-1027	36" x 48"	5.55	4.99	4.74



Taskboard®

The board of choice for interior and set design, architectural and topographical models, dioramas, and more. Taskboard is non-warping, easy to cut, and ideal for creating precise, invisible joints. Highly absorbent, it creates strong bonds with any glue, can be sanded easily, and accepts any waterbased or solvent-based paint, stain, or finish. Its ISO brightness of 62*/62* enhances shades, shadows, and details. Biodegradable and forested from a sustainable source, Taskboard's unique pulp stratification allows forming over steam or after soaking in cold water; it regains rigidity seconds after removal from steam, or overnight if soaked.

NUMBER	DESCRIPTION	EACH
A13161-1016	20" x 30" x 1/16", Natural	\$7.69
A13161-1026	20" x 30" x 1/16", White	7.69
A13161-1022	20" x 30" x 1/32", White	5.90



A-H Logan® FoamWerks™ Foam Board Cutters

FoamWerks tools cut foam board and cellfoam easily and precisely. They're perfect for framing, architectural models, signs, craft or school projects, and much more. All cutters feature ergonomic designs and quick-change blades.

A Circle Cutter — Cut perfect circles from 1–6" Dia. A center depth indicator shows blade progression for board depths from 1/8" to 1/2". Features a dual inch/metric rail, centering pin, magnetic blade slot, and clear acrylic safety dome. Comes with five blades. Use replacement blade A.

NUMBER	EACH
A57168-1020	\$37.68

B Freestyle Cutter — Cut freeform shapes with this innovative push-style cutter. It's easy to use — just insert the blade into the board and push to follow the desired shape. Features an ergonomic handle, on-board blade storage compartment, a blade safety shield, and two blades. Use replacement blade B.

NUMBER	EACH
A57168-1030	\$14.93

C Rabbet Cutter — Create perfect adjoining foam board joints with the Rabbet Cutter. Its innovative ergonomic construction and dual-blade action create one-stroke finished results. Features on-board blade storage and two blades. Use replacement blade C.

NUMBER	EACH
A57168-1070	\$14.93

D Straight Cutter — Cut perfect straight edges on any depth of foam board from 1/8" to 1/2". Cutter features adjustable blade depth, a quick-change blade clip, a magnetic blade slot, an on-board blade storage drawer, and five blades. Use replacement blade C.

NUMBER	EACH
A57168-1010	\$25.41



E V-Groove Cutter — Cut foam board V-grooves to perfection. The V-Groove Cutter features adjustable blade depth, quick-change blade clips, a magnetic blade slot, an on-board blade storage drawer, and five blades. Use replacement blade C.

NUMBER	EACH
A57168-1060	\$24.18

F Straight/Bevel Cutter — Economy and versatility combine in this cutter. Simply rotate the angled base block and it transforms from a straight cutter to a bevel cutter. Features include adjustable blade depth, an ergonomic handle, and on-board blade storage. The Straight/Bevel Cutter includes two blades and can be used with any suitable straight edge. Use replacement blade C.

NUMBER	EACH
A57168-1050	\$14.93

G Foam Board Hole Drill — Drill perfect holes in foam board using interchangeable quick-change drill tips. The drill comes with one each of 0.75", 0.50", and 0.28" Dia tips to drill holes in 3/16" foam board.

NUMBER	EACH
A57177-1001	\$26.44

H Channel Rail — This 32" aluminum rail features a channel rail on one side and dual scale on the other. Compatible with the Straight Cutter and V-Groove Cutter.

NUMBER	EACH
A57161-1000	\$24.15

Replacement Blades			
NUMBER	DESCRIPTION	EACH	
A57160-1020	Blade A, Pkg of 5	\$5.20	
A57177-3020	Blade A, Pkg of 20	13.23	
A57160-1040	Blade B, Pkg of 5	5.20	
A57177-3120	Blade B, Pkg of 20	17.84	
A57177-3205	Blade C, Pkg of 5	5.20	
A57177-3250	Blade C, Pkg of 20	13.23	

Logan® FoamWerks™ 5-Piece Kit

A value-priced kit featuring five essential Logan items: a Freestyle Cutter, a Rabbet Cutter, a Straight/Bevel Cutter, a Channel Rail, and a "Foamboard Magic" book filled with ideas for creative foam projects.

NUMBER	EACH
A58324-1059	\$72.25

Gatorfoam® Board

A lightweight, rigid display board with a polystyrene core and white surface. The core is very dense and firm and the surface is a wood fiber veneer laminate impregnated with resin for water resistance — great for outdoor use. It cuts cleanly with a knife, saw, or router. Choose Gatorfoam for your most durable displays, signage, and mounting surfaces. 32" x 40" sheets.

NUMBER	STYLE	EACH	6/EA	12/EA
A13201-1006	3/16" Thick	\$42.88	\$38.59	\$36.69
A13201-1016	1/2" Thick	68.61	61.76	58.71



Elmer's® White Foam Board

A virtually weightless board made of a polystyrene foam core laminated on both sides with a white coated-paper stock. It makes a wonderful background for large framed work and a great mounting board for posters and more. Use it for tabletop displays and signs. Foam board cuts easily with a mat knife and may be scored and folded for three-dimensional work. Note: 20" x 30" sheets available in multiple colors. Call for selection.

1/8" Thick, 32" x 40" Sheets				
NUMBER	PACKAGE OF	EACH	3/EA	6/EA
A13202-1027	10 Sheets	\$55.45	\$49.90	\$47.40
A13202-1037	25 Sheets	109.26	98.33	93.41

3/16" Thick, 20" x 30" Sheets				
NUMBER	PACKAGE OF	EACH	3/EA	6/EA
A13202-1023	10 Sheets	\$49.53	\$44.58	\$42.35
A13202-1033	25 Sheets	121.90	109.71	104.22
A13202-1026	100 Sheets	487.00	438.00	394.00

3/16" Thick, 24" x 36" Sheets				
NUMBER	PACKAGE OF	EACH	3/EA	6/EA
A13202-2020	25 Sheets	\$155.78	\$140.20	\$133.19

3/16" Thick, 30" x 40" Sheets				
NUMBER	PACKAGE OF	EACH	3/EA	6/EA
A13202-1016	10 Sheets	\$52.12	\$46.91	\$44.56
A13202-1116	25 Sheets	166.06	149.45	141.98

3/16" Thick, 32" x 40" Sheets				
NUMBER	PACKAGE OF	EACH	3/EA	6/EA
A13202-1007	10 Sheets	\$84.84	\$76.36	\$72.54
A13202-1017	25 Sheet	167.16	150.44	142.92

3/16" Thick, 40" x 60" Sheets Truck Shipment. See page 648 for details.

NUMBER	PACKAGE OF	EACH	3/EA	6/EA
A13202-1008	25 Sheets	\$328.00	\$295.20	\$280.44

1/2" Thick, 20" x 30"				
NUMBER	PACKAGE OF	EACH	3/EA	6/EA
A13202-1012	10 Sheets	\$63.90	\$57.51	\$54.63

1/2" Thick, 30" x 40"				
NUMBER	PACKAGE OF	EACH	3/EA	6/EA
A13202-1015	25 Sheets	\$317.00	\$285.30	\$271.03

1/2" Thick, 40" x 60" Truck Shipment. See page 648 for details.

NUMBER	PACKAGE OF	EACH	3/EA	6/EA
A13202-1048	12 Sheets	\$255.63	\$230.07	\$218.57

Elmer's® MightyCore™ Foam Board

Strong, lightweight, and versatile, MightyCore is easy to work with and incredibly durable, the perfect choice for signage, screenprints, mounting digital images, and more. Its polystyrene core is more dense than regular foam board, to resist denting, bending, and splintering, and the paper cap sheet has an underlying moisture barrier to prevent bowing and twisting. The smooth, "no-preparation" surface is receptive to most paints, inks, and adhesives. Choose a white surface with a white core or a black surface with a black core. 32" x 40" sheets are 1/4" thick.

NUMBER	STYLE	EACH	25/EA
A13212-2006	Black on Black	\$29.98	\$26.98



Elmer's® Pre-Cut Foam Board

Enjoy the benefits of foam board that is pre-cut to suit your needs. Available in convenient multi-packs, and in a variety of sizes, this foam board is uniform and ready to use. 3/16" thick.

White				
NUMBER	DESCRIPTION	EACH	15/EA	
A13228-1022	8" x 10", 5-pack	\$10.11	\$9.10	
A13228-1025	11" x 14", 4-pack	10.11	9.10	
A13228-1028	16" x 20", 3-pack	11.05	9.94	
A13228-1029	18" x 24", 2-pack	11.05	9.94	

Black				
NUMBER	DESCRIPTION	EACH	15/EA	
A13228-2025	11" x 14", 4-pack	\$9.87	\$8.88	
A13228-2028	16" x 20", 3-pack	10.52	9.47	
A13228-2029	18" x 24", 2-pack	9.87	8.88	

Elmer's® Colored Foam Board

Brilliantly colored, clay-coated surface paper, permanently bonded to both the front and back of the foam board. Core is strong, rigid, resilient polystyrene that resists denting and crushing. CFC-free. Easy to cut. Colored on one side, other side white, 3/16" thick, 20" x 30" sheet.

NUMBER	COLOR	EACH	25/EA
A13202-2013	Black	\$9.61	\$8.65
A13205-5003	Blue	9.61	8.65
A13205-2503	Gray	9.61	8.65
A13205-7003	Green	9.61	8.65
A13205-3300	Neon Pink	9.61	8.65
A13205-6003	Purple	9.61	8.65
A13205-3003	Red	9.61	8.65
A13205-5093	Sky Blue	9.61	8.65
A13205-2753	Slate Gray	9.61	8.65
A13202-8233	Tan	9.61	8.65
A13205-4003	Yellow	9.61	8.65

Pre-Cut Foam Board

Pre-cut foam board sheets make fast work of any project. Sold in convenient multi-packs, they're ideal for signage, framing, crafts, and more. 3/16" thick.

NUMBER	DESCRIPTION	EACH	12/EA
A13217-1055	5" x 5", 5-pack	\$2.08	\$1.87
A13217-1012	8" x 10", 5-pack	4.23	3.81
A13217-1023	9" x 12", 5-pack	4.40	3.96

When ordering sheets of paper or board larger than 18" x 24", a handling fee may apply. See page 648.



Blick® White Foam Board

This economical, lightweight board is made of a resilient, extruded polystyrene foam core laminated on both sides with a white coated-paper stock — the perfect background for larger framed works, a mounting board for artwork or posters, or for tabletop displays and signs. It cuts easily and can be scored and folded. 3/16" thick. Package of 25.

NUMBER	SIZE	EACH	3/EA	6/EA
A13209-1023	20" x 30"	\$97.52	\$87.77	\$83.38
A13209-1026	32" x 40"	133.73	120.35	114.34

Elmer's® White Acid-Free Foam Board

Acid-free foam board is the answer for professional framers, photographers, artists, and craftspeople who are concerned about preserving their work. The surface is completely acid-free and buffered to maintain its neutral pH level. The core is also chemically inert. It has all the qualities of regular foam board, including weight and moisture resistance. 3/16" thick sheets.

Antique White				
NUMBER	SIZE	EACH	3/EA	6/EA
A13202-1006	32" x 40", 10 Sheets	\$106.64	\$95.98	\$91.18
A13202-1106	32" x 40", 25 Sheets	241.16	217.04	206.19

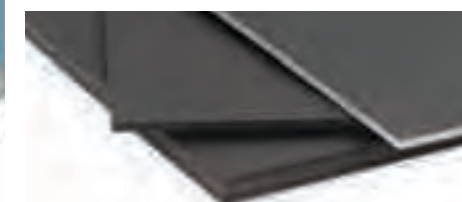

Elmer's® Black On Black Foam Board

Just like traditional foam board, except the foam core is black and laminated on both sides with black, coated paper stock — a dramatic background for displays.

20" x 30" Sheets — 3/16" thick.				
NUMBER	CARTON OF	EACH	3/EA	6/EA
A13202-2003	10 Sheets	\$49.80	\$44.82	\$42.58

24" x 36" Sheets — 3/16" thick.				
NUMBER	CARTON OF	EACH	3/EA	6/EA
A13202-2015	25 Sheets	\$181.66	\$163.49	\$155.32

32" x 40" Sheets — 3/16" thick.				
NUMBER	CARTON OF	EACH	3/EA	6/EA
A13202-2006	10 Sheets	\$73.18	\$65.86	\$62.57
A13202-2010	25 Sheets	245.19	220.67	209.64

32" x 40" Sheets — 1/2" thick.				
NUMBER	EACH	3/EA	6/EA	
A13202-9004	\$24.10	\$21.69	\$20.61	

48" x 96" Sheets — 1/2" thick. Truck Shipment. See page 648 for details.

NUMBER	CARTON OF	EACH	3/EA	6/EA
A13202-2140	12 Sheets	\$794.00	\$714.00	\$642.00

The Quick and Easy Way to Protect, Display, and Store Your Work!



Single Mat

Double Mat

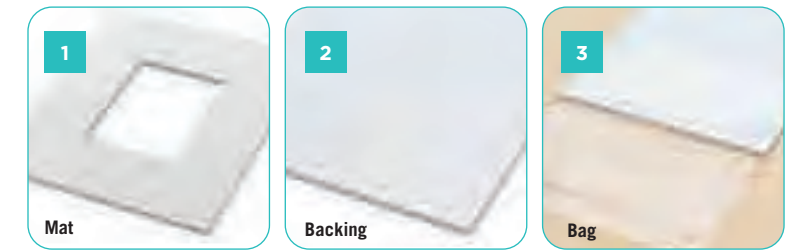

1 Mat

2 Backing

3 Bag

Blick® 3-in-1 Display System Archival Mat Kits

Show your work in a better light, easily and economically. A beveled mat is packaged with a foam board backing in a heavy-duty, archival-quality acetate bag. At art shows, it allows for a professional, matted presentation while protecting artwork from fingerprints, wind, and rain. And once the sale is made, customers can transport their purchases easily and safely. The actual opening size allows for an overlap of 1/4" (L x W). For example, the opening will be 4-3/4" x 6-3/4" for 5" x 7" artwork.

Single Mat

NUMBER	MAT SIZE	ARTWORK SIZE	EACH	10/EA	25/EA
A17226-1005	11" x 14"	5" x 7"	\$11.13	\$9.99	\$9.46
A17226-1004	14" x 16"	8" x 10"	15.83	14.25	13.46
A17226-1008	16" x 20"	11" x 14"	21.80	19.62	18.53
A17226-1002	22" x 28"	15" x 22"	45.50	40.95	38.67
A17226-1006	32" x 40"	22" x 30"	46.88	42.19	39.85

Double Mat

NUMBER	MAT SIZE	ARTWORK SIZE	EACH	10/EA	25/EA
A17226-1105	11" x 14"	5" x 7"	\$15.59	\$14.03	\$13.25
A17226-1104	14" x 16"	8" x 10"	20.99	18.90	17.85
A17226-1108	16" x 20"	11" x 14"	28.73	25.86	24.42
A17226-1102	22" x 28"	15" x 22"	64.23	57.81	54.60
A17226-1106	32" x 40"	22" x 30"	64.57	58.11	54.88

Blick Archival Acetate Display and Storage Bags — Use these crystal-clear bags with the 3-in-1 Display System or on their own. They're easy to seal, easy to reseal, and durable enough to use again and again.

NUMBER	DESCRIPTION	SIZE	EACH	10/EA	25/EA
A16969-1000	10-Pack	5" x 7"	\$1.40	\$1.27	
A16969-1005	10-Pack	11" x 14"	2.82	2.54	
A16969-1004	10-Pack	14" x 16"	3.91	3.52	
A16969-1008	10-Pack	16" x 20"	5.43	4.89	
A16969-1002	10-Pack	22" x 28"	9.24	8.33	
A16969-1006	10-Pack	32" x 40"	22.85	20.58	
A16969-1100	25-Pack	5" x 7"	3.05	2.73	
A16969-1105	25-Pack	11" x 14"	6.10	5.49	
A16969-1104	25-Pack	14" x 16"	8.72	7.85	
A16969-1108	25-Pack	16" x 20"	11.56	10.40	
A16969-1102	25-Pack	22" x 28"	20.18	18.16	
A16969-1106	25-Pack	32" x 40"	51.28	46.15	

Lineco® Photo Art Bags

Self-sealing 2 mil clear polypropylene bags are an economical archival storage alternative, sealing out dust and dirt while protecting photos from fingerprints and acidic skin oils.

Packs of 10

NUMBER	SIZE	EACH	6/EA
A17327-1012	8" x 10"	\$11.70	\$10.53
A17327-1011	8-1/2" x 11"	12.79	11.51
A17327-1005	11" x 14"	16.07	14.46
A17327-1016	11" x 17"	21.54	19.38
A17327-1013	13" x 19"	23.56	21.20
A17327-1006	16-3/4" x 21"	26.84	24.15

Packs of 50

NUMBER	SIZE	EACH
A17327-1057	5" x 7"	\$13.32
A17327-1810	8" x 10"	18.23
A17327-1017	11" x 17"	34.83
A17327-1019	13" x 19"	35.37
A17327-1620	16" x 20"	34.28



Blick® Presentation Boards

Ideal for mounting photographs and finished artwork, these rigid presentation boards work well with tapes and adhesives. Pure Black is significantly blacker than standard boards, with a solid black core and black, paper-lined sides. Pure White has a bright white surface that provides maximum contrast for graphic layouts and a variety of media. Acid-free and archival.

Pure Black

NUMBER	SIZE	EACH	6/EA
A13700-2012	8" x 10", 5-pack	\$7.81	\$7.03
A13700-2005	11" x 14", 5-pack	14.41	12.96
A13700-2015	15" x 20", 5-pack	15.57	13.99

Pure White

NUMBER	SIZE	EACH	6/EA
A13700-1312	8" x 10", 5-pack	\$7.81	\$7.03
A13700-1305	11" x 14", 5-pack	14.41	12.96
A13700-1315	15" x 20", 5-pack	15.57	13.99



Alvin® Archival Print Protectors

Ideal for storing and protecting artwork, photographs, limited edition prints, family heirlooms, maps, plans, old documents, and much more. Made from heavy-duty .010" clear polypropylene with reinforced black nylon sewn binding on all sides; top opening. Guaranteed archival-quality, pH-neutral, and acid-free. Each includes an acid-free black paper insert.

NUMBER

NUMBER	SIZE	EACH	6/EA
A16934-1015	11" x 14"	\$8.48	\$7.63
A16934-1019	14" x 18"	9.72	8.75
A16934-1023	17" x 22"	14.06	12.65
A16934-1025	18" x 24"	14.87	13.38
A16934-1027	20" x 26"	17.54	15.78
A16934-1031	22" x 30"	23.09	20.77
A16934-1033	26" x 32"	24.66	22.18
A16934-1041	30" x 40"	28.46	25.61



When ordering sheets of paper or board larger than 18" x 24", a handling fee may apply. See page 648.

Bainbridge® Super Black 100 Mounting Board

This double-sided, extra-deep black presentation mounting board has a scuff-resistant finish with a solid black core. Use it to professionally mount artwork, color computer laser output, photographs, comps, layouts, and prints. The edges can be bevel-cut for matting.

14-ply				
NUMBER	SIZE	EACH	25/EA	
A13404-2015	15" x 20"	\$3.66	\$3.29	
A13404-2020	20" x 30"	5.83	5.25	
A13404-2016	32" x 40"	11.16	10.04	

24-ply				
NUMBER	SIZE	EACH	25/EA	
A13404-2003	20" x 30"	\$8.58	\$7.72	
A13404-2006	32" x 40"	16.21	14.59	



Ultra-Black, Pack of 40

Crescent® No. 34 Double-Sided Pebble Embossed Matboard

Cream one side, white the other side, with gray core. Pebble surface on both sides. 14-ply (.048" thick). **Minimum order: 10 Sheets. (May be assorted.)**

NUMBER	SIZE	EACH	25/EA	50/EA
A17206-1398	14" x 22"	\$3.59	\$3.23	\$3.07
A17206-1392	22" x 28"	4.90	4.41	4.19
A17206-1397	28" x 44"	9.28	8.35	7.93



Strathmore® Museum Mounting Board

Made of 100% cotton fibers, the surface of this mounting board is designed to deliver a smoother, cleaner cut. The colors are solid throughout the board, made with pigments, and rated at 80 hours tested fade. Acid-free. 32" x 40".

2-Ply				
NUMBER	COLOR	EACH	25/EA	
A13001-1566	Antique White	\$14.82	\$13.34	
A13001-2206	Black	17.31	15.58	
A13001-1316	Cream	14.82	13.34	
A13001-2506	Gray	15.83	14.25	
A13001-8006	Natural	14.46	12.99	
A13001-2636	Photo Gray	15.83	14.25	
A13001-1986	Warm White	14.82	13.34	
A13001-1206	White	14.46	12.99	

4-Ply				
NUMBER	COLOR	EACH	12/EA	
A13001-1366	Antique White	\$26.84	\$24.16	
A13001-2006	Black	32.09	28.88	
A13001-1326	Cream	26.82	24.14	
A13001-2516	Gray	28.26	25.43	
A13001-8016	Natural	25.86	23.27	
A13001-2436	Photo Gray	28.26	25.43	
A13001-1786	Warm White	26.84	24.16	
A13001-1006	White	25.86	23.27	

Crescent® Ultra-Black Mounting Board

The BLACKEST available! This solid ultra-black board is smooth on one side for mounting artwork and photos, and texturized on the other to accept pastels, chalk, and acrylic paint. .055" thick.

NUMBER	CRESCENT #	SIZE	EACH	25/EA
A13016-2005	8.3C	15" x 20"	\$2.99	\$2.69
A13016-2003	8.6C	20" x 30"	5.63	5.07
A13016-2006	8	32" x 40"	12.37	11.13

Pack of 40

NUMBER	CRESCENT #	SIZE	EACH	25/EA
A17270-1400	SP8-0507C	5" x 7"	\$31.62	\$28.46
A17270-1423	SP8-0912C	9" x 12"	54.54	49.09
A17270-1405	SP8-1114C	11" x 14"	90.52	81.47

Pack of 3

NUMBER	CRESCENT #	SIZE	EACH	25/EA
A17270-1323	VP8-0912	9" x 12"	\$5.41	\$4.87
A17270-1305	VP8-1114	11" x 14"	8.66	7.79



Crescent® Perfect Mount® Self-Adhesive Mounting Board

An acid-free mounting board that carries a pH-neutral, pressure-activated adhesive, Perfect Mount permits easy positioning and repositioning until firm pressure is applied with a burnisher or press to create a permanent bond. It's a perfect choice for adhesive-resistant items such as photographs, varnished posters, prints on gloss paper, and laminated items. Easy to use; no sprays or wet pastes to deal with.

Single Thickness — 1/16" thick. White.

NUMBER	CRESCENT #	SIZE	EACH	12/EA
A23214-1002	PSX.08C	8" x 10"	\$2.42	\$2.18
A23214-1105	PSX.11C	11" x 14"	4.55	4.09
A23214-1108	PSX.16C	16" x 20"	6.40	5.76
A23214-1206	PSXC	32" x 40"	20.85	18.76

Double Thickness — 1/8" thick. White.

NUMBER	CRESCENT #	SIZE	EACH	12/EA
A23214-1005	PS3X.11C	11" x 14"	\$6.96	\$6.26
A23214-1008	PS3X.16C	16" x 20"	10.21	9.19
A23214-1006	PS3XC	32" x 40"	31.68	28.51

Foam Center — 3/16" thick. White. Complies with government standards for environmental safety.

NUMBER	CRESCENT #	SIZE	EACH	12/EA
A23214-1101	PSFC.20C	20" x 24"	\$18.29	\$16.46
A23214-1106	PSFCC	32" x 40"	28.75	25.87

Single Thickness — 1/6" thick. Black.

NUMBER	CRESCENT #	SIZE	EACH	12/EA
A23214-2212	PBX.08C	8" x 10"	\$3.50	\$3.15
A23214-2205	PBX.11C	11" x 14"	6.61	5.95
A23214-2208	PBX.16C	16" x 20"	9.28	8.35
A23214-2201	PBX.20C	20" x 24"	16.85	15.16
A23214-2206	PBXC	32" x 40"	30.35	27.31

Double Thickness — 1/8" thick. Black.

NUMBER	CRESCENT #	SIZE	EACH	12/EA
A23214-2005	PB3X.11C	11" x 14"	\$9.17	\$8.25
A23214-2008	PB3X.16C	16" x 20"	13.53	12.18
A23214-2001	PB3X.20C	20" x 24"	25.95	23.35
A23214-2006	PB3XC	32" x 40"	41.89	37.70

Foam Center — 3/16" thick. Black.

NUMBER	CRESCENT #	SIZE	EACH	12/EA
A23214-2106	PBFCC	32" x 40"	\$40.74	\$36.67

Crescent® All Black Mounting Board

This double-sided, solid black board cuts cleanly and is excellent for storyboards and photo mounting. The interior is made of 100% recycled fibers. Measures .05" or .095" thick.

NUMBER	SIZE	CRESCENT #	THICKNESS	EACH	5/EA
A13005-2005	15" x 20"	6008.3C	.05"	\$3.40	\$3.06
A13005-2003	20" x 30"	6008.6C	.05"	6.34	5.71
A13005-2006	30" x 40"	6008	.05"	10.71	9.64
A13021-2005	15" x 20"	6088.3C	.095"	5.29	4.76
A13021-2003	20" x 30"	6088.6C	.095"	8.78	7.90
A13021-2006	30" x 40"	6088	.095"	16.53	14.88

framing | MATBOARD | PRE-CUT

BLICK® pre-cut mats

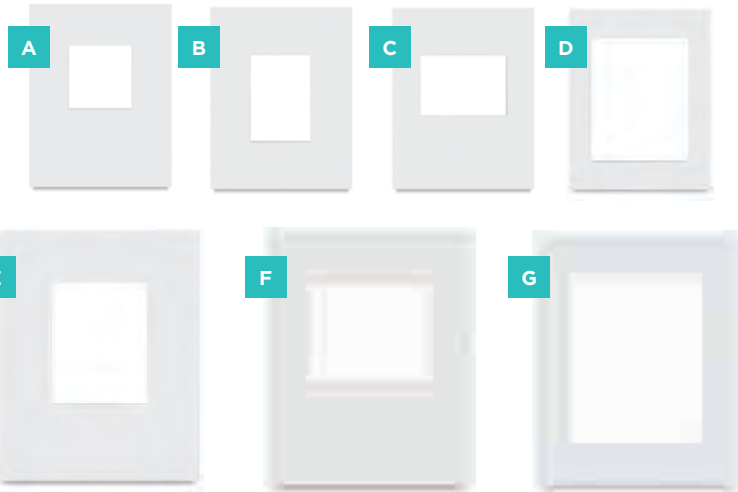

A-G Blick® Pre-Cut Archival Gallery Mat 6-Packs

These stunning mats have a double-thick, same-color bevel with off-center openings. Made from museum-quality 100% archival 8-ply rag, they also feature Artcare technology, which proactively filters pollutants and oxidizing gases to prevent art and photos from fading and discoloration. An archival mounting board is included with each mat. The actual opening size allows for an overlap of 1/2" on each side. For example, the opening will be 4-1/2" x 6-1/2" for 5" x 7" artwork.

White 11" x 14" Mat Size		
NUMBER	ARTWORK SIZE	EACH
A17223-1022	A 5" x 5" Portrait	\$40.81
A17223-1023	B 5" x 7" Portrait	40.81
A17223-1024	C 5" x 7" Landscape	40.81
A17223-1025	D 8" x 10" Center	40.81
White 16" x 20" Mat Size		
NUMBER	ARTWORK SIZE	EACH
A17223-1026	E 8" x 10" Portrait	\$61.93
A17223-1027	F 8" x 10" Landscape	61.93
A17223-1028	G 11" x 14" Center	61.93



Blick Pre-Cut Gallery Mat Size Chart

Mat Size	Artwork Size	Inside Opening Size
11" x 14"	5" x 5"	4-1/2" x 4-1/2"
11" x 14"	5" x 7"	4-1/2" x 6-1/2"
11" x 14"	8" x 10"	7-1/2" x 9-1/2"
16" x 20"	8" x 10"	7-1/2" x 9-1/2"
16" x 20"	11" x 14"	10-1/2" x 13-1/2"

Note: Artwork must be larger than opening dimensions.



H Blick® Black Core Pre-Cut Single Mats

Blick Black Core Pre-Cut Mats are made from high-quality 4-ply matboard with a black bevel. Each features a black core, surface, and backing papers, which are buffered and pH neutral — excellent protection for your artwork. The surface papers are fade-resistant and bleed-resistant.

NUMBER	MAT SIZE/ARTWORK SIZE	EACH	12/EA
A17220-2300	8" x 8" / 4" x 4"	\$2.64	\$2.38
A17220-2304	8" x 10" / 3" x 6"	3.51	3.16
A17220-2322 H	8" x 10" / 5" x 7"	3.51	3.16
A17220-2308	8" x 10" / 6" x 8"	3.51	3.16
A17220-2323	9" x 12" / 6" x 9"	4.40	3.96
A17220-2325	11" x 14" / 8" x 10"	5.50	4.95
A17220-2326	12" x 16" / 9" x 12"	7.03	6.33
A17220-2328	16" x 20" / 11" x 14"	8.33	7.50
A17220-2305	16" x 20" / 12" x 16"	8.33	7.50
A17220-2329	18" x 24" / 14" x 18"	10.67	9.60
A17220-2309	18" x 24" / 12" x 18"	13.22	11.90



Note: Artwork must be larger than opening dimensions.

Blick Pre-Cut Mat Size Chart

Mat Size	Artwork Size	Inside Opening Size
8" x 8"	4" x 4"	3-1/2" x 3-1/2"
8" x 10"	3" x 6"	2-1/2" x 5-1/2"
8" x 10"	5" x 7"	4-1/2" x 6-1/2"
8" x 10"	6" x 8"	5-1/2" x 7-1/2"
9" x 12"	6" x 9"	5-1/2" x 8-1/2"
11" x 14"	8" x 10"	7-1/2" x 9-1/2"
12" x 16"	9" x 12"	8-1/2" x 11-1/2"
16" x 20"	11" x 14"	10-1/2" x 13-1/2"
16" x 20"	12" x 16"	11-1/2" x 15-1/2"
18" x 24"	14" x 18"	13-1/2" x 17-1/2"
18" x 24"	12" x 18"	11-1/2" x 17-1/2"

Note: Artwork must be larger than opening dimensions.

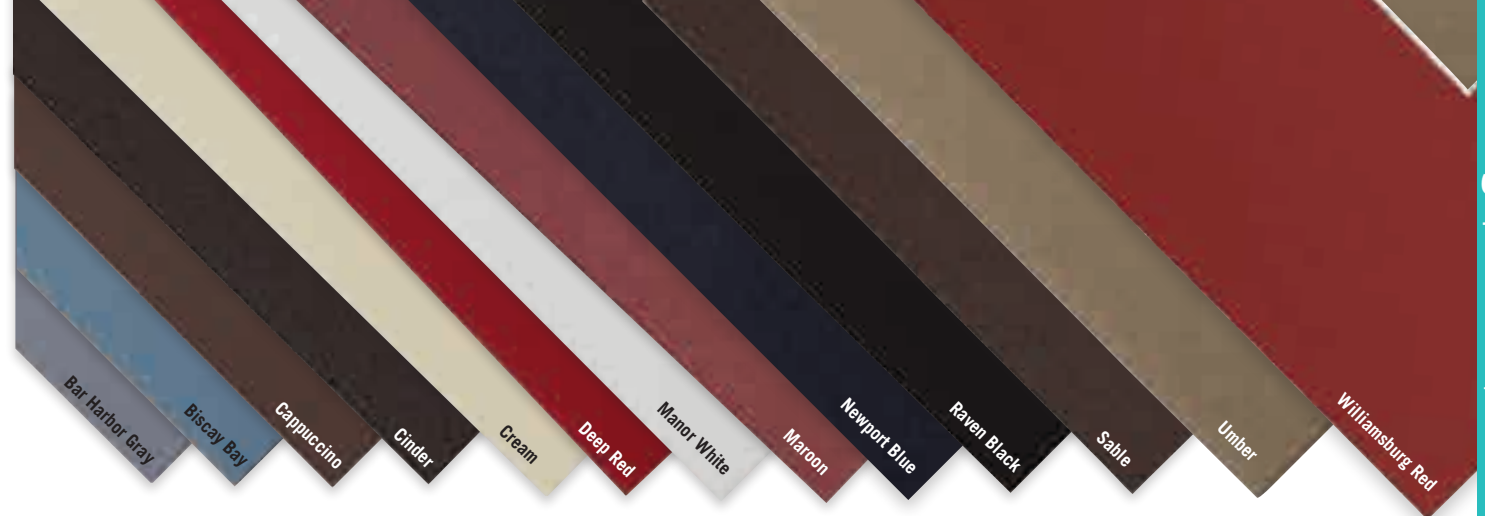

Blick® White Core Pre-Cut Single Mats

A high-quality matboard with the added benefits of a bright white core and a lower price than comparable brands. The core and surface paper offer excellent pH protection for your artwork. Pre-cut to fit standard frame sizes. Colors can be assorted for quantity pricing.

BLICK® gallery mats

COLOR	MAT SIZE: ART SIZE:	8" X 8" 4" X 4"	8" X 10" 4" X 6"	8" X 10" 5" X 7"	8" X 10" 6" X 8"	9" X 12" 6" X 9"	10" X 10" 4" X 4"	11" X 14" 8" X 10"	12" X 12" 8" X 8"	12" X 16" 9" X 12"	16" X 20" 11" X 14"	16" X 20" 12" X 16"	18" X 24" 12" X 18"	18" X 24" 14" X 18"
Bar Harbor Gray	A17220-2050	A17220-2057	A17220-2052	A17220-2054	A17220-2051	A17220-2063	A17220-2055	A17220-2067	A17220-1206	A17220-2058	A17220-2056	A17220-2059	A17220-2059	A17220-1209
Biscay Blue	—	—	A17220-5122	—	—	—	A17220-5125	—	A17220-5116	A17220-5128	—	—	A17220-5119	—
Cappuccino	—	—	A17220-8732	—	—	—	A17220-8735	—	A17220-8736	A17220-8738	—	—	—	A17220-8739
Cinder	—	A17220-1038	A17220-1034	—	—	—	—	—	—	—	A17220-1036	A17220-1036	A17220-1039	—
Cream	—	—	A17220-1102	—	A17220-1100	—	A17220-1105	—	A17220-1109	A17220-1108	—	—	—	A17220-1106
Deep Red	—	—	A17220-3712	—	A17220-3710	—	A17220-3715	—	A17220-3716	A17220-3718	—	—	—	A17220-3719
Manor White	A17220-1331	A17220-1334	A17220-1332	A17220-1330	A17220-1337	A17220-1093	A17220-1335	A17220-1097	A17220-1306	A17220-1338	A17220-1336	A17220-1336	A17220-1339	A17220-1309
Maroon	—	—	A17220-3552	—	—	—	A17220-3555	—	A17220-3558	A17220-3558	—	—	—	A17220-3349
Newport Blue	—	—	A17220-5302	—	—	—	A17220-5305	—	A17220-5126	A17220-5308	—	—	—	A17220-5129
Raven Black	A17220-2310	A17220-2314	A17220-2452	A17220-2318	A17220-2313	A17220-2303	A17220-2455	A17220-2307	A17220-2319	A17220-2458	A17220-2316	A17220-2459	A17220-2306	A17220-2306
Sable	—	—	A17220-8442	—	A17220-8440	—	A17220-8445	—	A17220-8446	A17220-8448	—	—	—	A17220-8449
Umber	—	—	A17220-8532	—	A17220-8533	—	A17220-8535	—	A17220-8536	A17220-8538	—	—	—	A17220-8539
Williamsburg Red	—	—	A17220-3762	—	—	—	A17220-3765	—	—	A17220-3768	—	—	—	—
	EACH \$2.71	EACH \$3.51	EACH \$3.51	EACH \$3.51	EACH \$4.40	EACH \$5.25	EACH \$5.50	EACH \$5.25	EACH \$7.03	EACH \$8.33	EACH \$8.33	EACH \$8.33	EACH \$10.67	EACH \$10.67
	12/EA 2.44	12/EA 3.16	12/EA 3.16	12/EA 3.16	12/EA 3.96	12/EA 4.72	12/EA 4.95	12/EA 4.72	12/EA 6.33	12/EA 7.50	12/EA 7.50	12/EA 7.50	12/EA 9.60	12/EA 9.60



Blick® White Core Pre-Cut Double Mats

14 beautiful color combinations to enhance your artwork. White Core double mats add elegance and offer further protection between your artwork and the glass. Colors can be assorted for quantity pricing.

OUTSIDE COLOR	LINER	MAT SIZE: ART SIZE:	8" X 8" 4" X 4"	8" X 10" 4" X 6"	8" X 10" 5" X 7"	8" X 10" 6" X 8"	9" X 12" 6" X 9"	11" X 14" 8" X 10"	12" X 16" 9" X 12"	16" X 20" 11" X 14"	16" X 20" 12" X 16"	18" X 24" 14" X 18"	18" X 24" 12" X 18" OR 13" X 19"
Bar Harbor Gray	Raven Black	—	—	—	A17221-1102	—	B17221-2053	A17221-1105	A17221-1106	A17221-1108	—	A17221-1109	—
Bar Harbor Gray	Smooth Black	A17221-2057	A17221-2052	—	A17221-2051	—	—	—	—	—	A17221-2058	—	A17221-2059
Biscay Blue	Newport Blue	—	—	A17221-5122	—	—	A17221-5121	A17221-5125	A17221-5126	A17221-5128	—	A17221-5129	—
Cinder	Smooth Black	—	A17221-1052	—	A17221-1032	—	—	—	—	—	A17221-1038	—	A17221-1029
Cream	Wlmsbrg Grn	—	—	A17221-1103	—	—	—	—	—	—	—	—	—
Manor White	Ecru	—	—	A17221-1332	—	—	A17221-1330	A17221-1333	A17221-1334	A17221-1338	—	A17221-1335	—
Newport Blue	Green Pear	—	—	A17221-5302	—	—	A17221-5305	—	—	—	—	—	—
Raven Black	Manor White	—	—	A17221-2312	—	—	A17221-2313	A17221-2315	A17221-2316	A17221-2318	—	A17221-2319	—
Sauterne	Sheer Blue	—	—	A17221-7412	—	—	A17221-7415	—	—	A17221-7418	—	—	—
Smooth Black	Smooth White	A17221-2027	A17221-2022	—	A17221-2021	—	—	—	—	—	A17221-2028	A17221-2029	—
Smooth White	Smooth Black	—	A17221-1042	—	A17221-1012	—	—	—	—	—	A17221-1018	—	A17221-1019
Soft Green	Cream	—	—	A17221-7432	—	—	A17221-7435	A17221-7436	A17221-7438	A17221-7438	—	A17221-7439	—
Umber	Cappuccino	—	—	A17221-8532	—	—	A17221-8533	A17221-8535	A17221-8536	A17221-8538	—	A17221-8539	—
Wlmsbrg Grn	Maroon	—	—	A17221-7492	—	—	A17221-7495	—	—	A17221-7498	—	—	—
		EACH \$4.18	EACH \$5.50	EACH \$5.50	EACH \$5.50	EACH \$7.04	EACH \$9.31	EACH \$10.57	EACH \$11.40	EACH \$11.40	EACH \$11.40	EACH \$16.39	EACH \$16.39
		12/EA 3.76	12/EA 4.95	12/EA 4.95	12/EA 4.95	12/EA 6.34	12/EA 8.38	12/EA 9.51	12/EA 10.26	12/EA 10.26	12/EA 10.26	12/EA 14.75	12/EA 14.75



SAVAGE



EXCLUSIVE!

Savage® Mat Mounts

Acid-free, non-archival mats with attractive, beveled inner edges, hinged at one side to a smooth, white mounting board. Packages of five.

Arctic White Mat Mounts — With textured surface.

NUMBER	OUTSIDE	ART SIZE	EACH	20/EA
A17202-1402	8" x 10"	4-1/2" x 6-1/2"	\$20.14	\$18.13
A17202-1403	9" x 12"	5-1/2" x 8-1/2"	25.40	22.86
A17202-1405	11" x 14"	7-1/2" x 9-1/2"	33.56	30.21
A17202-1408	16" x 20"	10-1/2" x 13-1/2"	47.44	42.70

Black Mat Mounts — With smooth surface.

NUMBER	OUTSIDE	ART SIZE	EACH	20/EA
A17202-2002	8" x 10"	4-1/2" x 6-1/2"	\$20.14	\$18.13
A17202-2003	9" x 12"	5-1/2" x 8-1/2"	25.40	22.86
A17202-2005	11" x 14"	7-1/2" x 9-1/2"	33.56	30.21
A17202-2008	16" x 20"	10-1/2" x 13-1/2"	47.44	42.70

Savage® Economy Matboard Packs

A Blick exclusive! Available in three popular colors and three sizes, Savage Economy Matboards have the finest 40 pt white cores and acid-free surface papers. Ideal for all artists, beginning to expert, and for students, each pack contains 25 or 50 matboards.

25-Pack

SIZE	BLACK	GRAY	WHITE	EACH
20" x 32"	A13039-2022	A13039-2502	A13039-1022	\$118.24
32" x 40"	A13039-2026	A13039-2506	A13039-1026	169.71

50-Pack

SIZE	BLACK	GRAY	WHITE	EACH
16" x 20"	A13039-2028	A13039-2508	A13039-1028	\$138.80

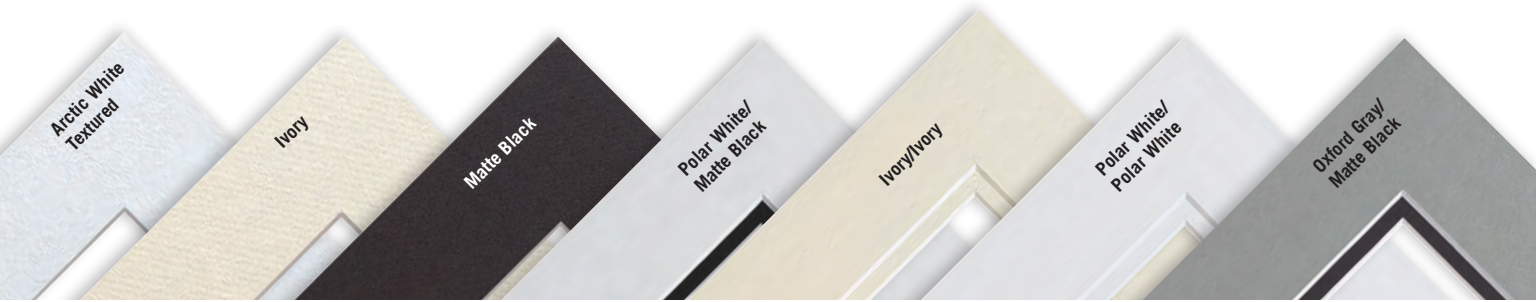

Savage® Value-Priced Pre-Cut Mats

Made from acid-free pulp and fade-resistant papers to ensure long-lasting quality. Precision-cut 45° bevel-edge openings. Individually shrink-wrapped. Single or double rectangular openings. No backing sheets. The actual opening size allows for an overlap of 1/4" on each side. For example, the opening will be 4-1/2" x 6-1/2" for 5" x 7" artwork. Colors for single and double mats can be assorted by size for quantity pricing.

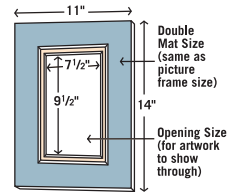

Single Mats – Mat Size/Artwork Size

COLOR	5" X 7 3/4" X 5"	8" X 10 3/4" X 6"	8" X 10 5/8" X 7"	11" X 14 7/8" X 10"	16" X 20 1/11" X 14"	16" X 20 1/11" X 17"	18" X 24 1/13" X 19"
Arctic White Textured	A17211-1301	A17211-1302	A17211-1303	A17211-1305	A17211-1308	A17211-1307	A17211-1309
Ivory	A17211-1261	A17211-1264	A17211-1260	A17211-1265	A17211-1268	A17211-1267	A17211-1269
Oxford Gray	A17211-2721	A17211-2724	A17211-2722	A17211-2725	A17211-2728	A17211-2727	A17211-2729
Matte Black	A17211-2491	A17211-2494	A17211-2492	A17211-2495	A17211-2498	A17211-2497	A17211-2499
Polar White	A17211-1471	A17211-1474	A17211-1472	A17211-1475	A17211-1478	A17211-1477	A17211-1479
	EACH 10/EA	EACH 10/EA	EACH 10/EA	EACH 10/EA	EACH 10/EA	EACH 10/EA	EACH 10/EA
	\$2.84 \$2.56	\$4.34 \$3.91	\$4.34 \$3.91	\$6.81 \$6.11	\$8.68 \$7.82	\$7.64 \$6.88	\$13.05\$11.76

Double Mats – Mat Size/Artwork Size

OUTSIDE COLOR	LINER	5" X 7 3/4" X 5"	8" X 10 3/4" X 6"	8" X 10 5/8" X 7"	11" X 14 7/8" X 10"	16" X 20 1/11" X 14"	16" X 20 1/11" X 17"	18" X 24 1/13" X 19"
Ivory	Ivory	A17208-1040	A17208-1042	A17208-1041	A17208-1045	A17208-1048	A17208-1047	A17208-1049
Oxford Gray	Matte Black	A17208-2380	A17208-2382	A17208-2381	A17208-2385	A17208-2388	A17208-2387	A17208-2389
Matte Black	Matte Black	A17208-2530	A17208-2532	A17208-2531	A17208-2535	A17208-2538	A17208-2537	A17208-2539
Polar White	Polar White	A17208-1010	A17208-1012	A17208-1011	A17208-1015	A17208-1018	A17208-1017	A17208-1019
Polar White	Matte Black	A17208-1480	A17208-1482	A17208-1481	A17208-1485	A17208-1488	A17208-1487	A17208-1489
		EACH 10/EA	EACH 10/EA	EACH 10/EA	EACH 10/EA	EACH 10/EA	EACH 10/EA	EACH 10/EA
		\$5.06 \$4.55	\$5.93 \$5.34	\$5.93 \$5.34	\$8.29 \$7.46	\$10.35 \$10.35	\$10.19 \$9.18	\$18.32 \$16.49

Pre-Cut Mat Frames

Use these inexpensive mat frames to present student artwork. The frames are made of lightweight cardboard and are die-cut but not beveled. Not archival. Available in White, Black, or assorted color.

Package of 60 White Mat Frames — 12 each of five sizes to fit over 18" x 24", 12" x 18", 9" x 12", and 6" x 9" artwork, plus 4" x 6" ovals.

NUMBER	EACH	12/EA
A17204-1011	\$17.20	\$15.48

Package of 12 White Mat Frames

NUMBER	OUTSIDE SIZE	ART SIZE	EACH	12/EA
A17204-1001	8" x 11"	6" x 9"	\$6.15	\$5.53
A17204-1003	11-1/2" x 16-1/2"	9" x 12"	7.35	6.60
A17204-1007	17" x 23"	12" x 18"	9.19	8.27

Package of 60 Assorted Color Mat Frames — 12 each of five sizes to fit over 18" x 24", 12" x 18", 9" x 12", and 6" x 9" artwork, plus 4" x 6" ovals.

NUMBER	EACH	12/EA
A17213-1060	\$42.80	\$38.53

Package of 12 Black Mat Frames

NUMBER	OUTSIDE SIZE	ART SIZE	EACH	12/EA
A17213-2003	11-1/2" x 16-1/2"	9" x 12"	\$16.30	\$14.66
A17213-2002	17" x 23"	12" x 18"	18.35	16.50



Value Pre-Cut Mats

Great for school art shows and temporary matting of prints and drawings. Each mat is cut from high-quality, lightweight white pebble board. The inside edge has been die-cut and scored, allowing you to bend the border inward or, if desired, simply bend the border to the back, color it with a marker or paint and return it to the front for a double mat effect. Backing sheets are not included. 50 mats per pack.

NUMBER	OUTSIDE	ART SIZE	EACH	4/EA
A17205-1002	8" x 10"	5" x 7"	\$28.32	\$25.49
A17205-1003	9" x 12"	6" x 9"	35.85	32.27
A17205-1005	11" x 14"	8" x 10"	37.86	34.08
A17205-1006	12" x 16"	9" x 12"	53.18	47.87
A17205-1008	16" x 20"	11" x 14"	73.50	66.16
A17205-1009	16" x 22"	12" x 18"	84.32	75.90
A17205-1102	22" x 28"	18" x 24"	118.08	106.30
A17205-1001	20" x 24"	16" x 20"	95.62	86.07



Cardboard Frames

Die-cut with clean edges. 4" x 4" inside, 6" x 6" outside. Perfect for framing 4" x 4" Metal Smith projects. Packages of 12 frames.

NUMBER	COLOR	EACH	12/EA
A60953-1009	White	\$5.20	\$4.68
A60953-1012	Woodgrain	7.57	6.80



Decorate-A-Frame Kit

Attach a favorite photo and decorate with paint, markers, buttons, mosaics, colored paper, felt, yarn foam, glitter, and more. Includes 25, 5" x 7" pieces of cardboard and 25 easels.

NUMBER	EACH	6/EA
A18935-0000	\$11.40	\$10.25



Single-Wing Locking Chipboard Easels

Heavy, tan, pressed chipboard, sharply die-cut. Locks tightly when open, folds flat when closed. Attach to backs of signs and posters with tape or glue (foam tape is excellent for this). Board is not included. Package of 100 easels. Sizes can be assorted for quantity pricing.

NUMBER	SIZE	EACH	10/EA	20/EA
A14902-2504	4"	\$11.10	\$9.99	\$9.49
A14902-2506	6"	13.59	12.23	11.62
A14902-2508	8"	15.42	13.87	13.18
A14902-2510	10"	18.65	16.79	15.95
A14902-2512	12"	22.65	20.39	19.37
A14902-2518	18"	40.99	36.89	35.05
A14902-2524	24"	70.35	63.30	60.15

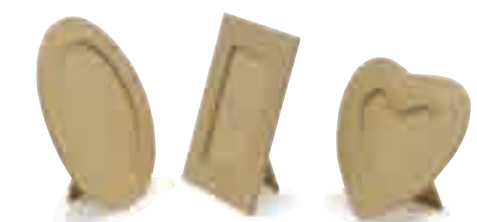

Creativity Street® Papier Mâché Frames Class Pack

Ready to decorate with paints, markers, crayons, and craft materials, these fun papier mâché frames are great for school or team projects. Each class pack contains 24 assorted styles. For details, visit DickBlick.com.

NUMBER	EACH	6/EA
A62101-1001	\$39.79	\$35.81

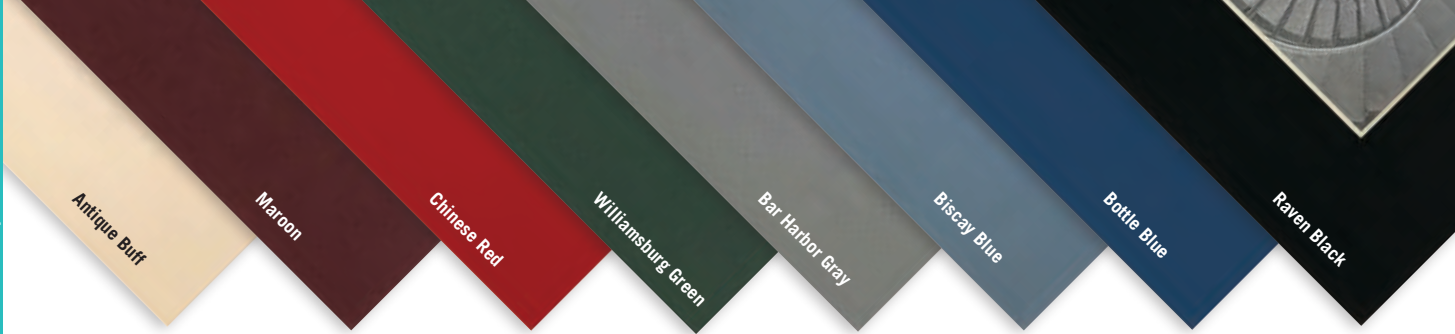

Crescent® Pre-Cut Mats

Made with Crescent decorative surface matboard!

Crescent gallery-quality, pre-cut mats have perfectly cut, 45° beveled openings. The mat with light cream core is pH-neutral and buffered. The fine-quality surface paper is highly fade-resistant. Shrink-wrapped.

Colors can be assorted for quantity pricing.

COLOR	8" X 10"	11" X 14"	12" X 16"	16" X 20"	18" X 24"
Arctic White	A13012-1132	A13012-1135	A13012-1136	A13012-1138	A13012-1139
Antique Buff	A13012-1112	A13012-1115	A13012-1116	A13012-1118	A13012-1119
Maroon	A13012-3342	A13012-3345	A13012-3346	A13012-3348	A13012-3349
Chinese Red	A13012-3272	A13012-3275	A13012-3276	A13012-3278	A13012-3279
Williamsburg Green	A13012-7492	A13012-7495	A13012-7496	A13012-7498	A13012-7499
Bar Harbor Gray	A13012-2052	A13012-2055	A13012-2056	A13012-2058	A13012-2059
Biscay Blue	A13012-5122	A13012-5125	A13012-5126	A13012-5128	A13012-5129
Bottle Blue	A13012-5192	A13012-5195	A13012-5196	A13012-5198	A13012-5199
Raven Black	A13012-2452	A13012-2455	A13012-2456	A13012-2458	A13012-2459
	EACH 12/EA	EACH 12/EA	EACH 12/EA	EACH 12/EA	EACH 12/EA
	\$3.30 \$2.97	\$5.24 \$4.72	\$6.12 \$5.51	\$8.62 \$7.76	\$12.50 \$11.25

Crescent Pre-Cut Size Chart

Mat Size	Artwork Size	Inside Opening Size
8" x 10"	5" x 7"	4-1/2" x 6-1/2"
11" x 14"	8" x 10"	7-1/2" x 9-1/2"
12" x 16"	9" x 12"	8-1/2" x 11-1/2"
16" x 20"	12" x 16"	11-1/2" x 15-1/2"
18" x 24"	14" x 18"	13-1/2" x 17-1/2"

Note: Artwork should be larger than opening dimensions



For Crescent® Matboard Blanks, visit DickBlick.com.

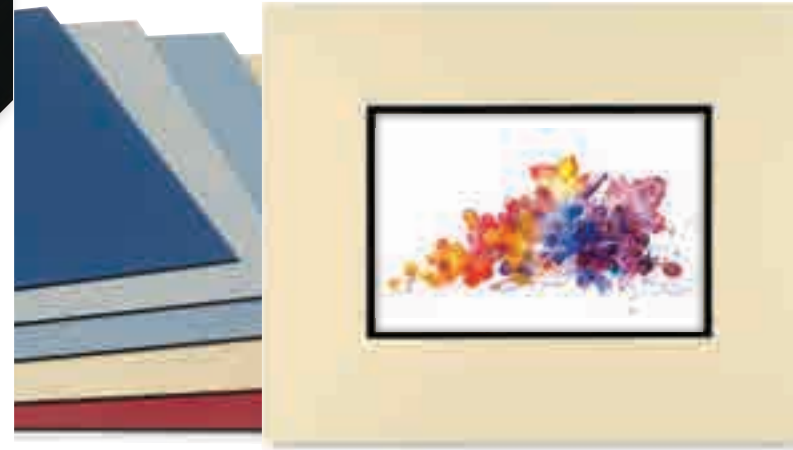

Crescent® Double-Sided Matboard

These versatile matboards feature two usable sides. Double-sided boards are available with two smooth surfaces or with a pebbled surface texture. Light cream core. pH-neutral. 4-ply, 1/16" thick. Made in the USA.

Colors can be assorted for quantity pricing.

COLOR	CRESCENT #	20" X 32"	32" X 40"
White & Cream (Smooth)	33	A17207-1003	A17207-1006
		EACH \$5.23	EACH \$9.21
		25/EA 4.71	25/EA 8.30
COLOR	CRESCENT #	20" X 32"	32" X 40"
White & Cream (Pebble)	34	A17203-1403	A17203-1406
		EACH \$5.70	EACH \$10.84
		25/EA 5.13	25/EA 9.76
COLOR	CRESCENT #	20" X 32"	32" X 40"
White & Black (Pebble)	3921	A17203-2003	A17203-2006
		EACH \$5.99	EACH \$10.84
		25/EA 5.39	25/EA 9.76

Crescent® Black Core Matboard

Add a dramatic black bevel to your mat designs! The surface and backing papers and the black wood-pulp core are all buffered with calcium carbonate to slow the damage of acid and lignin. This range is best suited for decorative, non-conservation framing. pH-neutral. 4-ply, 1/16" thick. Made in the USA.

Colors can be assorted for quantity pricing.

COLOR	CRESCENT #	20" X 32"	32" X 40"
Arctic White	63297	A13007-1133	A13007-1136
Alabaster-Flannel	63300	A13007-1363	A13007-1476
Spice Ivory	61028	—	A13007-1056
Wheat	61029	—	A13007-8997
Mist	61088	A13007-1453	A13007-1356
Sandstone	61061	A13007-8474	A13007-8477
Oak Brown	6984	A13007-8364	A13007-8367
Dark Ash	61033	A13007-2623	A13007-2626
Maroon	61038	A13007-3573	A13007-3576
Crimson	61023	A13007-3167	A13007-3164
Williamsburg Green	6988	A13007-7495	A13007-7498
Dark Olive	61032	A13007-7083	A13007-7086
Biscay Blue	61073	A13007-5124	A13007-5127
Lapis	63326	A13007-5253	A13007-5256
Newport Blue	6977	A13007-5313	A13007-5316
Silver Gray	61027	—	A13007-2596
Medium Gray	61025	A13007-2313	A13007-2306
Fog-Flannel	6915	A13007-2193	A13007-2196
Granite-Flannel	63311	A13007-2634	A13007-2637
Mist Gray	61002	—	A13007-2346
Photo Gray	61019	A13007-2443	A13007-2446
Raven Black	6989	A13007-2464	A13007-2467
Manor Black	63344	A13007-2773	A13007-2776
		EACH \$7.53	EACH \$14.70
		25/EA 6.78	25/EA 13.23

When ordering sheets of paper or board larger than 18" x 24", a handling fee may apply. See page 648.

Crescent® White Core Matboard

Brilliant white cores complement rich surface colors and add a crisp, clean edge to any artwork. Ideal for the non-conservation matting and framing of open-end reproductions, posters, and decorative art. pH-neutral. 4-ply, 1/16" thick. Made in the USA. Colors can be assorted for quantity pricing.

COLOR	CRESCENT #	20" X 32"	32" X 40"
Very White	SRM918	A13007-1512	A13007-1514
Arctic White	SRM3297	A13007-1132	A13007-1134
Palm Beach White	SRM987	A13007-1382	A13007-1384
Antique White	SRM3293	A13007-1372	A13007-1377
Cream	SRM961	—	A13007-1107
Ivory	SRM1008	A13007-1042	A13007-1044
Sand	SRM948	A13007-8512	A13007-8515
Dark Olive	SRM1032	—	A13007-7077
Sauterne	SRM1089	—	A13007-7417
Avocado	SRM1084	—	A13007-7464
Williamsburg Green	SRM988	—	A13007-7492
Sheer Blue	SRM3369	—	A13007-5007
Biscay Blue	SRM1073	—	A13007-5122
Lapis	SRM3326	A13007-5262	A13007-5264
Newport Blue	SRM977	—	A13007-5307
Maroon	SRM1038	—	A13007-3557
Williamsburg Red	SRM1042	—	A13007-3767
Chinese Red	SRM3214	A13007-3272	A13007-3274
Classic Brown	SRM1040	A13007-8172	A13007-8174
Fog	SRM915	A13007-2182	A13007-2184
Bar Harbor Gray	SRM976	—	A13007-2066
Sable	SRM997	—	A13007-8447
Smooth Black	SRM921	A13007-2652	A13007-2654
Raven Black	SRM989	—	A13007-2457
Chartreuse	SRM3586	—	A13007-0006
Hot Pink	SRM3585	—	A13007-3066
		EACH \$6.44	EACH \$12.32
		25/EA 5.80	25/EA 11.09



Crescent® Select™ Conservation Solids Matboard

Give your photos and other artwork a gallery/museum aesthetic at a value price. An elegant option for use with valuable art originals, open-reproduction prints, and any other artwork that doesn't require a premium-quality cotton mat, each mat features a solid color throughout and is color-matched to allow maximum versatility and usability. Acid-free, lignin-free, and 100% archival. 32" x 40". Made in the USA. Colors can be assorted for quantity pricing.

COLOR	CRESCENT #	4 PLY	8 PLY
Vivid White	5700	A13024-1514	A13024-1518
White	5702	A13024-1024	A13024-1028
Antique White	5703	A13024-1414	A13024-1418
Cream	5704	A13024-1104	A13024-1108
Tan	5706	A13024-8234	A13024-8238
Dark Brown	5708	A13024-8834	—
Gray	5709	A13024-2544	—
Dark Gray	5710	A13024-2534	—
Deep Black	5711	A13024-2144	A13024-2148
Cloud Gray	5712	A13024-2524	A13024-2528
Neutral Gray	5713	A13024-2514	—
Classic Gray	5714	A13024-2504	—
		EACH \$19.39	EACH \$35.48
		25/EA \$17.45	25/EA \$31.93



Crescent® Select™ Conservation Solids Pre-Cut Mats

Preserve, enhance, and add depth to your artwork with these solid-color mats from Crescent. Designed to protect photos, artwork, reproduction prints, and more, these value-priced, solid-color mats are great for applications where a premium-quality cotton matboard is not required. Choose coordinated 4-ply and 8-ply colors for maximum versatility and a gallery/museum aesthetic. Acid-free, lignin-free, and 100% archival.

Colors can be assorted for quantity pricing.

Single 4-Ply

COLOR	8" X 10"	11" X 14"	16" X 20"	18" X 24"
Vivid White	A17230-1042	A17230-1045	A17230-1048	A17230-1049
Antique White	A17230-1412	A17230-1415	A17230-1418	A17230-1419
Gray	A17230-2542	A17230-2545	A17230-2548	A17230-2549
Dark Gray	A17230-2532	A17230-2535	A17230-2538	A17230-2539
Deep Black	A17230-2142	A17230-2145	A17230-2148	A17230-2149
	EACH 25/EA	EACH 25/EA	EACH 25/EA	EACH 25/EA
	\$5.55 \$4.99	\$8.80 \$7.92	\$14.23 \$12.81	\$20.24 \$18.22

Single 8-Ply

COLOR	8" X 10"	11" X 14"	16" X 20"	18" X 24"
Vivid White	A17230-1082	A17230-1085	A17230-1088	A17230-1089
Deep Black	A17230-2182	A17230-2185	A17230-2188	A17230-2189
	EACH 25/EA	EACH 25/EA	EACH 25/EA	EACH 25/EA
	\$6.04 \$5.44	\$10.18 \$9.16	\$17.76 \$15.98	\$28.03 \$25.23

Double Mat, 4-Ply + 4-Ply

OUTSIDE COLOR (4-PLY)	LINER (4-PLY)	8" X 10"	11" X 14"	16" X 20"	18" X 24"
Vivid White	Vivid White	A17230-1192	A17230-1195	A17230-1198	A17230-1199
Vivid White	Deep Black	A17230-1292	A17230-1295	A17230-1298	A17230-1299
Gray	Dark Gray	A17230-2592	A17230-2595	A17230-2598	A17230-2599
Dark Gray	Deep Black	A17230-2222	A17230-2225	A17230-2228	A17230-2229
		EACH 25/EA	EACH 25/EA	EACH 25/EA	EACH 25/EA
		\$8.47 \$7.62	\$13.06 \$11.75	\$22.04 \$19.84	\$34.77 \$31.29

BAINBRIDGE[™] novacore[™] matboard

Bainbridge Novacore Matboards come in a superior range of color choices that match the most modern design and home décor trends. White core matboards have a specially formulated, pure bright white core for decorative bevels with a neutral color contrast. Black core matboards have a matching black backing for dramatic, sophisticated bevels. Acid-free, buffered surface, core, and backing.

Bainbridge[®] Novacore[™] Matboards

Bainbridge Novacore Matboards come in a superior range of color choices that match the most modern design and home décor trends. White core matboards have a specially formulated, pure bright white core for decorative bevels with a neutral color contrast. Black core matboards have a matching black backing for dramatic, sophisticated bevels. Acid-free, buffered surface, core, and backing. Colors can be assorted for quantity pricing.

COLOR	16" X 20"	32" X 40"
Bright White	A13044-1158	A13044-1150
Soft White	A13044-1188	A13044-1180
Ivory	A13044-1048	A13044-1040
Sandbar	A13044-8548	A13044-8540
Peat	A13044-7928	A13044-7920
Orange	A13044-4518	A13044-4510
Fireball Red	A13044-3128	A13044-3120
Sangria	A13044-6418	A13044-6410
Midnight	A13044-5808	A13044-5800
Forest Green	A13044-7278	A13044-7270
Goldenrod	A13044-4918	A13044-4910
Porpoise Grey	A13044-2548	A13044-2540
Charcoal	A13044-2138	A13044-2130
Black	A13044-2018	A13044-2010
	EACH \$4.44	EACH 10.67
	10/EA 3.99	10/EA 9.60

COLOR	16" X 20"	32" X 40"
Metallic Gold	A13044-9018	A13044-9010
Metallic Silver	A13044-9338	A13044-9330
	EACH \$6.67	EACH \$16.03
	10/EA 5.99	10/EA 14.43

COLOR	16" X 20"	32" X 40"
Soft White	A13044-1198	A13044-1190
Black	A13044-2028	A13044-2020
	EACH \$4.44	EACH \$10.67
	10/EA 3.99	10/EA 9.60

Bainbridge[®] Papermat Decorative Cream Core Matboards

A solution for decorative matting where long-term protection isn't required, Papermat Matboards in a range of colors can be used for both mounting and presentation. They have a smooth, scuff-resistant surface with consistent colors and a clean, cream-colored core. 4-ply. 32" x 40". Made in the USA.

Colors can be assorted for quantity pricing.

NUMBER	COLOR	NUMBER	COLOR
A13017-1966	Biscuit	A13017-7916	Oyster
A13017-1776	Bisque	A13017-8670	Peat
A13017-1716	Brilliant White	A13017-2420	Pewter
A13017-4250	Canary	A13017-1430	Porcelain
A13017-2130	Charcoal	A13017-3680	Rouge
A13017-1106	Cream	A13017-4146	Sea Foam
A13017-7030	Dark Green	A13017-8120	Sienna
A13017-5210	Delft Blue	A13017-7706	Soapstone
A13017-1320	Fabric White	A13017-5350	Slate Blue
A13017-2630	Granite	A13017-1310	Super White
A13017-5800	Liberty Blue	A13017-2550	TV Gray
A13017-7310	Meadow Green	A13017-2500	Warm Gray
A13017-8376	Midnight Blue		
A13017-1286	Off White		

EACH	10/EA
\$12.23	\$10.99

CRESCENT[®] decorative matboard

Crescent[®] Decorative Matboard

Ideal for the non-conservation matting and framing of open-end reproductions, posters, and decorative art. These standard matboards feature richly colored surfaces on a light cream core. pH-neutral. 4-ply, 1/16" thick. Made in the USA. Colors can be assorted for quantity pricing.

COLOR	CRESCENT #	20" X 32"	32" X 40"	COLOR	CRESCENT #	20" X 32"	32" X 40"
Very White	918	A13007-1513	A13007-1516	Biscay Blue	1073	A13007-5123	A13007-5126
Arctic White	3297	A13007-1143	A13007-1146	Dvnshre Blue-Flannel	3307	A13007-5223	A13007-5226
Palm Beach White	987	A13007-1393	A13007-1406	Baltic Blue	1054	A13007-5613	A13007-5616
Winter White	3354	A13007-1523	A13007-1526	Newport Blue	977	A13007-5303	A13007-5306
Alabaster-Flannel	3300	A13007-1353	A13007-1456	Delft Blue	1053	A13007-5213	A13007-5216
Snow White	3290	A13007-1183	A13007-1186	Madagascar Pink	1078	A13007-3533	A13007-3536
Pompano Beach White	1000	A13007-1413	A13007-1416	English Rose	909	A13007-3403	A13007-3406
Antique White	3293	A13007-1373	A13007-1376	Violet	905	A13007-6503	A13007-6506
Spice Ivory-Flannel	1028	A13007-1443	A13007-1446	Las Cruces Purple	1076	A13007-6113	A13007-6116
Ivory White	1008	A13007-1043	A13007-1046	Maroon	1038	A13007-3553	A13007-3556
Wheat-Flannel	1029	A13007-8993	A13007-8996	Auburn	1039	A13007-3113	A13007-3116
Antique Buff	1095	A13007-1114	A13007-1216	Red	900	A13007-3003	A13007-3006
French Gray	962	A13007-2903	A13007-2906	Chinese Red	3214	A13007-3273	A13007-3276
Olde Tan-Flannel	1051	A13007-8393	A13007-8396	Burnt Orange	1077	A13007-4523	A13007-4526
Sandstone	1061	A13007-8473	A13007-8476	Redwood	1057	A13007-3643	A13007-3646
French Buff	3291	A13007-4163	A13007-4166	Russet	996	A13007-3513	A13007-3516
Yellow	902	A13007-4003	A13007-4006	Rust	1085	A13007-8433	A13007-8436
Chamois Gold	994	A13007-4093	A13007-4096	Oak Brown	984	A13007-8363	A13007-8366
Saffron	3320	A13007-4283	A13007-4286	Tampico Brown	986	A13007-8503	A13007-8506
Saddle Tan	983	A13007-8463	A13007-8466	Pyro Brown	985	A13007-8423	A13007-8426
Pewter	1090	A13007-2423	A13007-2426	Dark Ash	1033	A13007-2613	A13007-2616
Sauterne	1089	A13007-7413	A13007-7416	Fudge	1097	A13007-8893	A13007-8896
Light Umbria	3352	A13007-8273	A13007-8276	Classic Brown	1040	A13007-8173	A13007-8176
Moss	3346	—	A13007-7526	Sepia	1096	A13007-8083	A13007-8086
Moss Point Green	1001	A13007-7313	A13007-7316	Sable	997	A13007-8443	A13007-8446
Grass Green	1045	A13007-7243	A13007-7246	Sundown Shadow	3359	A13007-2144	A13007-2146
Avocado	1084	A13007-7463	A13007-7466	Silver Gray-Flannel	1027	A13007-2583	A13007-2586
Dark Olive	1032	A13007-7073	A13007-7076	Medium Gray	1025	A13007-2303	A13007-2316
Kelly Green	993	A13007-7363	A13007-7366	Mist Gray	1002	A13007-2323	A13007-2326
Williamsburg Green	988	A13007-7494	A13007-7497	Copley Gray	935	A13007-2083	A13007-2086
Congo Green	978	A13007-7193	A13007-7196	Fog-Flannel	915	A13007-2183	A13007-2186
Midnight Green	3342	A13007-7303	A13007-7306	Dawn Gray	974	A13007-2113	A13007-2116
Black Watch	3333	A13007-2743	A13007-2746	Granite-Flannel	3311	A13007-2633	A13007-2636
Aqua Green	3357	A13007-7113	A13007-7116	Bar Harbor Gray	976	A13007-2053	A13007-2056
Bimini Blue	1080	A13007-5093	A13007-5096	Photo Grey	1019	A13007-2433	A13007-2436
Marine Blue	1082	A13007-5553	A13007-5556	Dark Gray	924	A13007-2533	A13007-2536
China Blue	3360	A13007-5034	A13007-5036	Smooth Black	921	A13007-2653	A13007-2656
Lapis	3326	A13007-5263	A13007-5266	Raven Black	989	A13007-2453	A13007-2456
Indigo	3358	A13007-5203	A13007-5206	Silver-Metallic	969	A13007-2593	A13007-2597
Dusty Blue	1024	A13007-2124	A13007-5236	Old Gold-Metallic	968	A13007-4243	A13007-4246
French Blue	972	A13007-5573	A13007-5576	Gold-Metallic	970	A13007-4053	A13007-4056

EACH	10/EA	EACH	10/EA
\$5.41	\$9.53	\$5.41	\$9.53
25/EA 4.87	25/EA 8.58	25/EA 4.87	25/EA 8.58

When ordering sheets of paper or board larger than 18" x 24", a handling fee may apply. See page 648.



450-1

Logan® 450-1 Artist Elite Mat Cutter

The same price as the original, with even more features!

- 40" cutting capacity
- Cuts standard-thickness (4-ply) matboards
- Bevel and straight cutting heads
- Hinged guiderail
- Parallel mat guide in aluminum channels
- Squaring bar
- Removable 20" measuring bar with production stop for quick downsizing
- Heavy-duty pull-style bevel cutter with anti-crawl pin
- Includes five Logan #270 blades

NUMBER	DESCRIPTION	SIZE	EACH
A17196-4501	Model 450-1	40" long	\$277.63



550-1

Logan® 550-1 & 560-1 Simplex Classic Mat Cutters

A full-featured, artist-quality mat cutter at an economy price!

- Makes both bevel and straight cuts
- 40" or 60" capacity
- Parallel mat guide in aluminum channels
- 27" squaring arm with stop
- Hinged guide rail with production stops

NUMBER	DESCRIPTION	SIZE	EACH
A18300-1040	Model 550-1	40" Long	\$376.00
A18300-1060	Model 560-1	60" Long	453.00

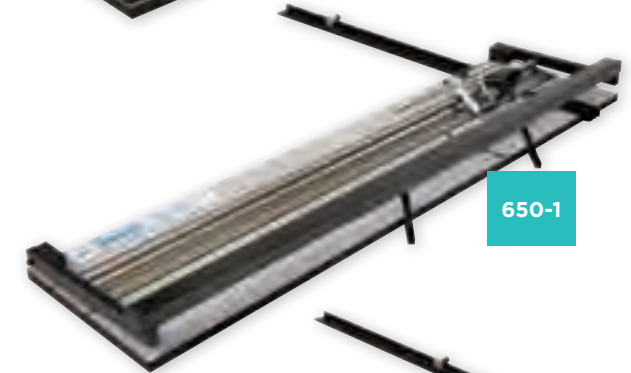

650-1

Logan® 650-1, 655-1 & 660-1 Framer's Edge Elite Mat Cutters

For high-production jobs or small projects!

- Non-stick cutting bar needs no lubrication
- Single-pull, dual cutting head for bevel/straight cuts and 4-ply/8-ply mats
- Lifetime-guaranteed Delrin bearings
- 3/4" composite base with durable laminate surface
- Hinged guide rail, parallel mat guide, and three movable production stops
- 32" and 9" squaring arms
- Includes 10 Logan #269 replacement blades (also accepts #268 blades for 8-ply cutting)

NUMBER	DESCRIPTION	SIZE	EACH
A18303-1040	Model 650-1	40" Long	\$771.00
A18303-1048	Model 655-1	48" Long	866.00
A18303-1060	Model 660-1	60" Long	975.00



750-1

Logan® 750-1 & 760-1 Simplex Elite Mat Cutters

A sizing tool, trimmer, and mat cutter in one!

- Cuts glass, Plexiglas®, paper, and photos
- Hinged guide rail with production stops
- Parallel mat guide in aluminum channels
- 27" squaring arm with production stop and optional flush-cut squaring arm
- Bevel and straight cutting heads
- 8-ply bevel cutter
- Glass cutter
- Acrylic Plexiglas® cutter
- Paper trimmer
- Uses Logan #270 or #271 blades and #786 glass wheel

NUMBER	DESCRIPTION	SIZE	EACH
A18301-1040	Model 750-1	40" long	\$491.00
A18301-1060	Model 760-1	60" long	581.00



2200

Fletcher® 2200 Professional Mat Cutting System

- Accuracy and precision in sizing mats, bevel cuts, and V-grooves
- 8" wide border slices through foam board up to 1/2" thick
- Unique pin locator for setting precise, accurate borders and faster repeat cutting
- Comfort grips with easy-load magnetic blade lock
- Anodized aluminum base resists warping
- Includes 10 blades for bevel cutting and 10 blades for straight cutting
- Instruction video (VHS or PAL format)
- Two-year manufacturer's warranty
- FOB Factory. See page 648 for details.

NUMBER	LENGTH	EACH
AF17139-1048	48"	\$2526.00
AF17139-1060	60"	2881.00

Measuring Stops — Eliminate the time-consuming technique of drawing lines on the back of the mat. Stops assure minimum overcuts and prevent undercuts. FOB Factory. See page 648 for details.

NUMBER	EACH
AF17139-9000	\$335.00

Clamp Lifters — Set of two. Mounted on the underside of a hinge bracket with the spring-loaded roller resting on the base. This allows both hands to be free to position the slip sheet and mat. Slight downward pressure lowers the mat clamp. FOB Factory. See page 648 for details.

NUMBER	EACH
AF17139-9001	\$92.56



BLICK® modern gallery frames

- Made from lightweight recycled materials
- Includes ready-to-display artwork
- Includes styrene face, hanging hardware, and a bevel-cut mat

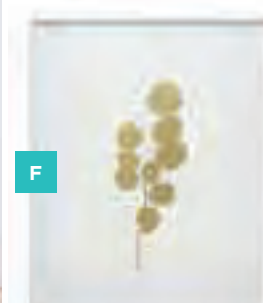
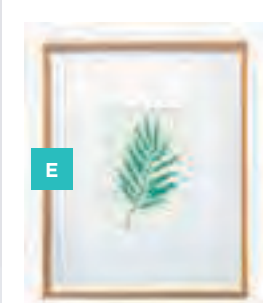
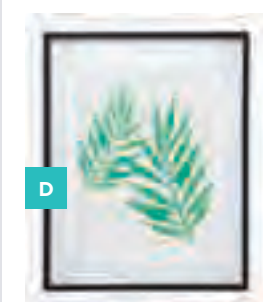
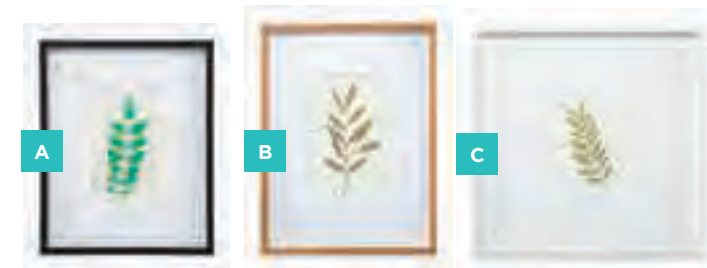

A-F Blick® Modern Gallery Frames

These modern frames with a flat profile are ideal for framing your favorite artwork, both alone or in groupings. Hang and display right away with the included artwork, or replace it with your own photos, sketches, or prints. Made from a lightweight recycled material, they're easy to transport and hang. Includes hanging hardware and a bevel-cut mat. Each includes a styrene face with a protective film on both sides. Remove the film before displaying your art.

FRAME SIZE	OPENING SIZE	BLACK	GOLD	WHITE	EACH	4/EA
8" x 10"	4" x 6"	A A17397-2021	A17397-9011	A17397-1021	\$9.27	\$8.34
9" x 12"	5" x 7"	A17397-2022	B A17397-9012	A17397-1022	10.99	9.89
12" x 12"	5" x 5"	A17397-2023	A17397-9013	C A17397-1023	13.74	12.36
11" x 14"	8" x 10"	D A17397-2024	A17397-9014	A17397-1024	13.74	12.36
11" x 14"	5" x 7"	A17397-2025	E A17397-9015	A17397-1025	13.74	12.36
16" x 20"	11" x 14"	A17397-2026	A17397-9016	F A17397-1026	25.40	22.86



BLICK® photo frames

- Contemporary flat frame
- For photos, sketches, and prints
- Styrene face



Blick® Sheffield Photo Frames

A contemporary flat frame with a 1-1/4" wide profile, the Sheffield is ideal for framing your favorite photos, sketches, or prints. Available in Black (with a bevel-cut black or white mat) and Silver (with a bevel-cut white mat), these lightweight polystyrene frames also include a backing board, hanging hardware, an easel back, and a styrene face with a protective film on both sides to prevent scratches and smudges. Remove the film before displaying your art. Note: The 4" x 6", 5" x 7", and 8-1/2" x 11" frames do not include a mat.

FRAME SIZE	OPENING SIZE	BLACK	SILVER	BLACK/WHITE	EACH	6/EA
4" x 6"	—	A18999-2023	A18999-9333	—	\$6.78	\$6.10
5" x 7"	—	A18999-2020	A18999-9330	—	7.99	7.20
8" x 10"	5" x 7"	A18999-2012	A18999-3032	A18999-2021	16.96	15.25
8" 1/2 x 11"	—	A18999-2010	A18999-3030	—	14.38	12.94
9" x 12"	6" x 8"	A18999-2013	A18999-3033	A18999-2022	21.21	19.10
10" x 10"	8" x 8"	A18999-2011	A18999-3031	A18999-2024	21.21	19.10
11" x 14"	8" x 10"	A18999-2015	A18999-3035	A18999-2026	22.98	20.69
12" x 12"	10" x 10"	A18999-2014	A18999-3034	A18999-2025	24.78	22.30
12" x 16"	8" x 12"	A18999-2016	A18999-3036	A18999-2027	26.62	23.96
16" x 20"	11" x 14"	A18999-2018	A18999-3038	A18999-2028	33.98	30.58
18" x 24"	14" x 18"	A18999-2019	A18999-3039	A18999-2029	35.80	32.23



BLICK® gallery frames

- Great for gallery settings
- Includes ready-to-display abstract artwork
- Includes glass face, hanging hardware, template, and acid-free, beveled mat



Blick® Emery Wood Gallery Frames

These beautiful wood frames are ideal for artwork of all kinds — or display them with the striking facepaper artwork already in the frame! Available in two colors and a variety of popular sizes, Blick Emery Frames also include a glass face and an acid-free, beveled mat with a white core for displaying artwork with or without a mat. The finished back has multiple sawtooth hangers for vertical or horizontal placement. The 9" x 12" size also has an easel back for tabletop display. A paper template makes hanging quick and easy.

FRAME SIZE	OPENING SIZE	BLACK	WHITE	EACH
9" x 12"	5" x 7"	A17573-2023	A17573-1023	\$10.97
11" x 14"	5" x 7"	A17573-2025	A17573-1025	13.78
16" x 16"	8" x 8"	A17573-2026	A17573-1026	20.48
16" x 20"	8" x 10"	A17573-2028	A17573-1028	24.48



Blick® Chelsea Metal Gallery Frames

These ready-to-hang-frames arrive beautifully matted and outfitted with an engaging piece of abstract art. Hang and display right away, or replace the art with your own favorite photo, sketch, or painting. The Chelsea features a modern gallery-style profile in matte finishes. Choose Black, Gold, or Silver (the 16" x 20" frame is only available in Black). Templates are included for easy vertical or horizontal hanging. The 9" x 12" frame also includes an easel back for tabletop display. A glass face and hanging hardware are included. See below for artwork size when using the mat.

FRAME SIZE	OPENING SIZE	BLACK	GOLD	SILVER	EACH
9" x 12"	5" x 7"	A17365-2023	A17365-9013	A17365-9333	\$21.35
11" x 14"	5" x 7"	A17365-2025	A17365-9015	A17365-9335	24.61
16" x 16"	8" x 8"	A17365-2026	A17365-9016	A17365-9336	39.41
16" x 20"	8" x 10"	A17365-2028	—	—	46.83



BLICK® wood and metal gallery frames

- Great for creating custom galleries
- For canvas, photos, and other artwork
- Most versatile frames
- Styrene face



Black Wood Gallery Frame

new look!

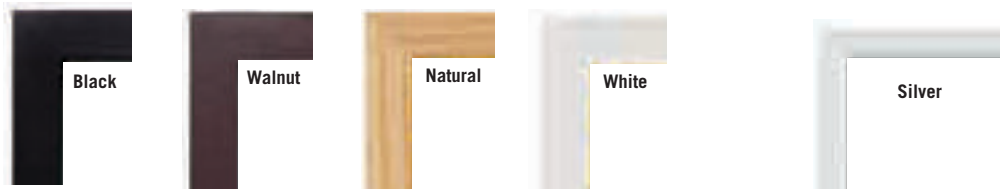
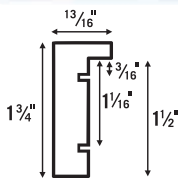

Blick® Wood Gallery Frames

Made of fine quality solid wood with a lovely natural woodgrain, this frame's 1-3/4" deep profile with two sets of back grooves is ideal for accommodating up to 1-1/2" deep stretched canvases, photographs, and other artwork. A rigid backboard with swivel clips ensures stability. Each frame ships with a styrene face for safer transportation to art fairs, galleries, and customers. A protective film covers the styrene face and should be peeled away before use.

SIZE	BLACK	WALNUT	NATURAL	WHITE	EACH	6/EA
4" x 6"	A18862-2021	A18862-8911	A18862-1911	A18862-1021	\$18.13	\$16.37
5" x 7"	A18862-2020	A18862-8910	A18862-1910	A18862-1020	20.96	18.92
6" x 6"	A18862-2066	—	—	A18862-1026	20.96	18.92
8" x 10"	A18862-2012	A18862-8912	A18862-1912	A18862-1282	25.81	23.30
9" x 12"	A18862-2023	A18862-8923	A18862-1923	A18862-1283	27.50	24.75
10" x 10"	A18862-2010	—	—	A18862-1284	27.42	24.68
11" x 14"	A18862-2005	A18862-8905	A18862-1905	A18862-1295	32.31	29.07
12" x 12"	A18862-2004	A18862-8904	A18862-1904	A18862-1285	32.31	29.07
12" x 16"	A18862-2006	A18862-8906	A18862-1906	A18862-1296	36.28	32.69
14" x 18"	A18862-2017	—	—	—	40.31	36.26
16" x 20"	A18862-2008	A18862-8908	A18862-1908	A18862-1298	49.99	44.99
18" x 24"	A18862-2009	A18862-8909	A18862-1909	A18862-1299	60.51	54.46
20" x 24"	A18862-2001	—	—	—	64.51	58.07
24" x 30"	A18862-2013	A18862-8913	A18862-1913	A18862-1023	80.67	72.60
24" x 36"	A18862-2015	—	—	A18862-1025	96.77	87.06
30" x 40"	A18862-2026	A18862-8926	A18862-1926	A18862-1024	113.15	101.83

Blick® Metal Gallery Frames

A smooth finish on the face and a single-brushed finish on the sides complement artwork beautifully. This frame will hold a stretched canvas on a standard bar. Each frame ships with a styrene face for safer transportation to art fairs, galleries, and customers. The styrene face has a film on both sides that protects it from scratches and smudges. Remove the film before displaying your art.

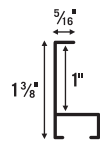

SIZE	BLACK	SILVER	EACH	6/EA
6" x 6"	A17085-2011	A17085-9311	\$18.54	\$16.68
8" x 10"	A17085-2002	A17085-9302	20.60	18.54
9" x 12"	A17085-2001	A17085-9301	23.68	21.30
10" x 10"	A17085-2012	A17085-9312	26.07	23.46
11" x 14"	A17085-2005	A17085-9305	29.17	26.25
12" x 12"	A17085-2004	A17085-9304	31.57	28.42
12" x 16"	A17085-2006	A17085-9306	32.95	29.66
14" x 18"	A17085-2013	A17085-9313	36.39	32.74
16" x 20"	A17085-2008	A17085-9308	41.20	37.08
18" x 24"	A17085-2009	A17085-9309	48.05	43.24
20" x 24"	A17085-2014	A17085-9314	56.97	51.27
24" x 30"	A17085-2003	A17085-9303	70.70	63.62
24" x 36"	A17085-2007	A17085-9307	80.99	72.91
26" x 34"	A17085-2015	A17085-9315	84.44	75.99
30" x 40"	A17085-2016	A17085-9316	98.16	88.35

BLICK® wood floater frames

- Stretched canvas appears to float in the frame
- Ideal for Blick gallery wrap canvases
- Pre-drilled holes allow for easy assembly

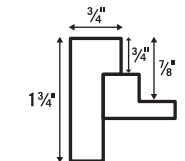

3/4" Width, For 3/4" or 7/8" Deep Canvas

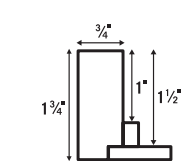

3/4" Width, For 1-1/2" Deep Canvas

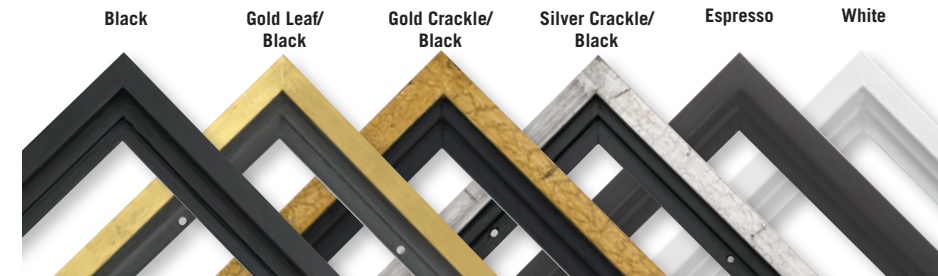

Blick® Wood Floater Frames

These popular frames feature fine finishes and hand-applied colors for a stunning presentation.

3/4" Width — For 3/4" or 7/8" Deep Canvas

SIZE	BLACK	GOLD LEAF/BLACK	GOLD CRACKLE/BLACK	SILVER CRACKLE/BLACK	ESPRESSO	WHITE	EACH	5/EA
8" x 8"	A18848-2188	A18848-2388	A18848-9188	A18848-9330	A18848-8188	A18848-1188	\$16.12	\$14.51
8" x 10"	A18848-2112	A18848-2312	A18848-9112	A18848-9332	A18848-8112	A18848-1112	25.71	23.14
9" x 12"	A18848-2123	A18848-2323	A18848-9123	A18848-9333	A18848-8123	A18848-1123	27.99	25.19
11" x 14"	A18848-2105	A18848-2305	A18848-9105	A18848-9335	A18848-8105	A18848-1105	31.36	28.22
12" x 12"	A18848-2122	A18848-2322	A18848-9122	A18848-9334	A18848-8122	A18848-1122	31.36	28.22
12" x 16"	A18848-2106	A18848-2306	A18848-9106	A18848-9336	A18848-8126	A18848-1126	34.08	30.67
14" x 18"	A18848-2117	A18848-2307	A18848-9017	A18848-9337	A18848-8127	A18848-1127	34.49	31.04
16" x 20"	A18848-2108	A18848-2308	A18848-9108	A18848-9338	A18848-8108	A18848-1108	41.09	36.98
18" x 24"	A18848-2109	A18848-2309	A18848-9109	A18848-9339	A18848-8109	A18848-1109	47.62	42.86
20" x 24"	A18848-2101	A18848-2301	A18848-9011	A18848-9331	A18848-8121	A18848-1121	49.65	44.68

3/4" Width — For 1-1/2" Deep Canvas

SIZE	BLACK	GOLD LEAF/BLACK	GOLD CRACKLE/BLACK	SILVER CRACKLE/BLACK	ESPRESSO	WHITE	EACH	5/EA
8" x 8"	A18848-2088	A18848-2288	A18848-9088	A18848-9340	A18848-8088	A18848-1088	\$16.12	\$14.51
8" x 10"	A18848-2012	A18848-2212	A18848-9012	A18848-9342	A18848-8012	A18848-1012	25.71	23.14
9" x 12"	A18848-2023	A18848-2223	A18848-9023	A18848-9343	A18848-8023	A18848-1023	27.99	25.19
11" x 14"	A18848-2005	A18848-2205	A18848-9005	A18848-9345	A18848-8005	A18848-1005	31.36	28.22
12" x 12"	A18848-2022	A18848-2222	A18848-9022	A18848-9344	A18848-8022	A18848-1022	31.36	28.22
12" x 16"	A18848-2026	A18848-2206	A18848-9006	A18848-9346	A18848-8026	A18848-1026	34.08	30.67
14" x 18"	A18848-2027	A18848-2207	A18848-9007	A18848-9347	A18848-8027	A18848-1027	34.49	31.04
16" x 20"	A18848-2008	A18848-2208	A18848-9008	A18848-9348	A18848-8008	A18848-1008	41.09	36.98
18" x 24"	A18848-2009	A18848-2209	A18848-9009	A18848-9349	A18848-8009	A18848-1009	47.62	42.86
20" x 24"	A18848-2021	A18848-2201	A18848-9001	A18848-9341	A18848-8021	A18848-1021	49.65	44.68

Espresso



- Budget-friendly value packs
- Ideal for wall groupings and art shows
- Pair frames with canvas panels and wood panels

Blick® Super Value Floater Frame Packs

Another super value from Blick! Specially designed to hold Blick Super Value Stretched Canvases and select sizes of Super Value Wood Panels (8" x 8", 9" x 12", and 11" x 14"), these black frames come equipped with industrial-grade adhesive for quick, easy canvas mounting, and sawtooth hangers for vertical or horizontal hanging. Inside frame depth is 0.625". Made of recycled materials. Note: Super Value Canvases will be flush with the frame. Super Value Wood Panels will extend slightly beyond the frame's profile.

NUMBER	SIZE	PKG	EACH
A18715-2022	8" x 10"	5	\$51.93
A18715-2023	9" x 12"	4	52.52
A18715-2028	16" x 20"	5	110.38

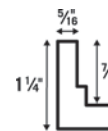

Easy on Classroom Budgets!

See page 144 and page 157 for our Super Value Canvas and Super Value Panel Packs.

AMPERSAND™



Ampersand™ Wood Panel Floater Frames

Finally, a frame designed for wood panels! Made from premium hardwood, these professional-quality frames have a wider base that eliminates damage to the panel cradle. A higher profile and deeper rabbet protect panel corners, too. Easy to use — just add your artwork to the frame with the included screws, attach to eyelets, add wire, and hang flush to the wall. Hanging hardware included. The 7/8" deep sizes also fit 3/4" deep stretched canvas and flat panels with the included riser system. For more sizes, visit DickBlick.com.

Thin Style

SIZE	DEPTH	BLACK	EACH	4/EA	WHITE	EACH	4/EA	MAPLE	EACH	4/EA
8" x 8"	7/8"	A17563-2010	\$32.26	\$29.03	A17563-1010	\$32.26	\$29.03	A17563-8910	\$33.50	\$30.15
8" x 10"	7/8"	A17563-2012	31.80	28.62	A17563-1012	31.80	28.62	A17563-8912	34.16	30.74
11" x 14"	7/8"	A17563-2015	44.56	40.10	A17563-1015	44.56	40.10	A17563-8915	47.03	42.33
12" x 12"	7/8"	A17563-2014	42.88	38.59	A17563-1014	42.88	38.59	A17563-8914	45.25	40.72
16" x 20"	7/8"	A17563-2018	67.06	60.35	A17563-1018	67.06	60.35	A17563-8918	68.33	61.50
8" x 8"	1-1/2"	A17563-2011	33.50	30.15	A17563-1011	33.50	30.15	A17563-8911	35.98	32.38
8" x 10"	1-1/2"	A17563-2013	35.86	32.27	A17563-1013	35.86	32.27	A17563-8913	39.56	35.60
11" x 14"	1-1/2"	A17563-2016	48.31	43.48	A17563-1016	48.31	43.48	A17563-8916	52.03	46.83
12" x 12"	1-1/2"	A17563-2017	48.31	43.48	A17563-1017	48.31	43.48	A17563-8917	51.55	46.39
16" x 20"	1-1/2"	A17563-2019	67.66	60.89	A17563-1019	67.66	60.89	A17563-8919	71.28	64.15

Bold Style

SIZE	DEPTH	BLACK	EACH	4/EA	WHITE	EACH	4/EA	MAPLE	EACH	4/EA
8" x 8"	7/8"	A17563-2020	\$35.30	\$31.77	A17563-1020	\$35.30	\$31.77	A17563-8920	\$36.52	\$32.87
8" x 10"	7/8"	A17563-2022	36.24	32.62	A17563-1022	36.24	32.62	A17563-8922	39.89	35.90
11" x 14"	7/8"	A17563-2025	46.85	42.16	A17563-1025	46.85	42.16	A17563-8925	51.54	46.39
12" x 12"	7/8"	A17563-2024	46.85	42.16	A17563-1024	46.85	42.16	A17563-8924	50.45	45.40
16" x 20"	7/8"	A17563-2028	74.28	66.85	A17563-1028	74.28	66.85	A17563-8928	78.22	70.40
8" x 8"	1-1/2"	A17563-2021	35.30	31.77	A17563-1021	35.30	31.77	A17563-8921	36.52	32.87
8" x 10"	1-1/2"	A17563-2023	35.42	31.88	A17563-1023	35.42	31.88	A17563-8923	38.96	35.06
11" x 14"	1-1/2"	A17563-2026	46.85	42.16	A17563-1026	46.85	42.16	A17563-8926	51.51	46.36
12" x 12"	1-1/2"	A17563-2027	46.85	42.16	A17563-1027	46.85	42.16	A17563-8927	51.56	46.40
16" x 20"	1-1/2"	A17563-2029	63.36	56.99	A17563-1029	63.36	56.99	A17563-8929	66.70	60.03

See page 152-153 for our full assortment of Ampersand™ Wood Panels.



Black



White



Maple

BLICK® simplon plein air frames

- Beautiful solid wood frames
- Ideal for paintings, prints, photos, mirrors

For more Simplon frames, visit DickBlick.com.

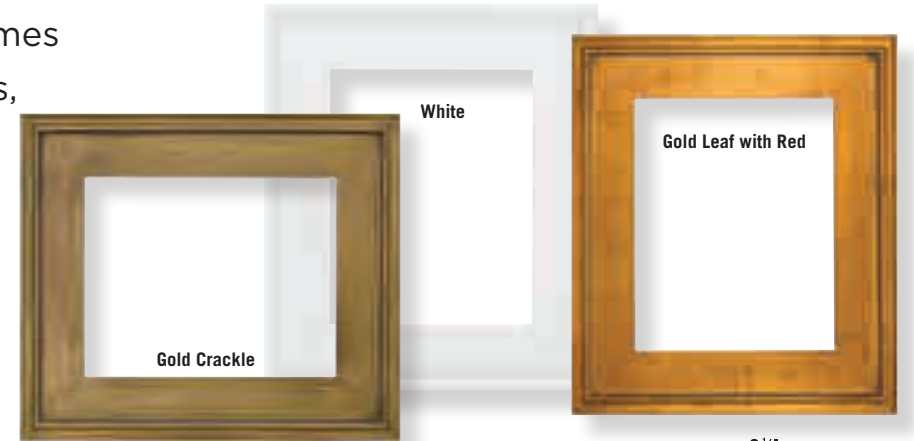

Blick® Simplon Econo Plein Air Frames

A scaled-down version of our popular Simplon frame, the Simplon Econo offers equally elegant simplicity in six rich finishes. These solid wood frames are made in the USA. 3/8" rabbet.

SIZE	BLACK	ESPRESSO	GOLD LEAF WITH BLACK	GOLD LEAF WITH RED	GOLD CRACKLE	WHITE	EACH	10/EA
4" x 6"	A18888-2004	A18888-8514	A18888-9004	—	—	—	\$24.82	\$22.34
5" x 7"	A18888-2000	A18888-8510	A18888-9000	—	—	—	28.60	25.74
6" x 6"	A18888-2003	A18888-8513	A18888-9003	—	—	—	28.60	25.74
8" x 10"	A18888-2012	A18888-8502	A18888-9012	A18888-3722	A18888-9022	A18888-1022	36.91	33.22
9" x 12"	A18888-2013	A18888-8503	A18888-9013	A18888-3723	A18888-9023	A18888-1023	39.54	35.59
11" x 14"	A18888-2015	A18888-8505	A18888-9015	A18888-3725	A18888-9025	A18888-1025	41.43	37.29
12" x 16"	A18888-2016	A18888-8506	A18888-9016	A18888-3726	A18888-9026	A18888-1026	44.56	40.10
14" x 18"	A18888-2017	A18888-8507	A18888-9017	A18888-3727	A18888-9027	A18888-1027	50.58	45.52
16" x 20"	A18888-2018	A18888-8508	A18888-9018	A18888-3728	A18888-9028	A18888-1028	56.79	51.11
18" x 24"	A18888-2019	A18888-8509	A18888-9019	A18888-3729	A18888-9029	A18888-1029	65.08	58.57
20" x 24"	A18888-2011	A18888-8501	A18888-9011	A18888-3721	A18888-9021	A18888-1021	66.48	59.83

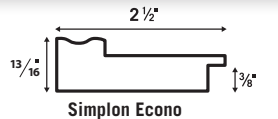

Blick® Simplon Plein Air Frames

An extremely versatile, beautifully simple frame for paintings, prints, watercolors, photos, or mirrors. Made in the USA, these solid wood frames feature a deep 1/2" rabbet.

SIZE	ANTIQUE BRONZE	WHITE	ESPRESSO	SPECKLED SILVER	GOLD LEAF	GOLD CRACKLE	SILVER LEAF	BLACK	SPECKLED GOLD	EACH	5/EA
4" x 6"	—	—	A18846-8002	—	A18846-5002	—	A18846-9302	A18846-2002	—	\$26.76	\$24.08
5" x 7"	—	—	A18846-8004	—	A18846-5004	—	A18846-9304	A18846-2004	—	28.26	25.43
6" x 6"	—	—	A18846-8003	—	A18846-5003	—	A18846-9306	A18846-2003	—	28.26	25.43
8" x 8"	—	A18846-1088	A18846-8088	A18846-9488	A18846-5088	A18846-5188	A18846-9388	A18846-2088	A18846-9188	30.56	27.50
8" x 10"	A18846-8112	A18846-1012	A18846-8012	A18846-9412	A18846-5012	A18846-5112	A18846-9312	A18846-2012	A18846-9112	36.88	33.19
9" x 12"	A18846-8123	A18846-1023	A18846-8023	A18846-9423	A18846-5023	A18846-5123	A18846-9323	A18846-2023	A18846-9123	39.58	35.62
10" x 10"	A18846-8110	—	A18846-8010	A18846-9410	A18846-5010	A18846-5110	A18846-9310	A18846-2010	—	38.30	34.47
11" x 14"	A18846-8105	A18846-1005	A18846-8005	A18846-9405	A18846-5005	A18846-5105	A18846-9305	A18846-2005	A18846-9105	44.90	40.41
12" x 12"	A18846-8111	—	A18846-8011	A18846-9411	A18846-5011	A18846-5111	A18846-9311	A18846-2011	A18846-9111	44.90	40.41
12" x 16"	A18846-8106	A18846-1006	A18846-8006	A18846-9406	A18846-5006	A18846-5106	A18846-9306	A18846-2006	A18846-9106	50.55	45.49
12" x 24"	—	—	A18846-8024	—	A18846-5024	A18846-5124	A18846-9324	A18846-2024	A18846-9124	68.88	61.99
14" x 18"	A18846-8117	A18846-1017	A18846-8017	A18846-9417	A18846-5017	—	A18846-9317	A18846-2017	A18846-9117	60.95	54.85
16" x 20"	A18846-8108	A18846-1008	A18846-8008	A18846-9408	A18846-5008	A18846-5108	A18846-9308	A18846-2008	A18846-9108	68.88	61.99
18" x 24"	A18846-8109	A18846-1009	A18846-8009	A18846-9409	A18846-5009	A18846-5109	A18846-9309	A18846-2009	A18846-9109	81.04	72.94
20" x 24"	—	—	—	—	A18846-5001	A18846-5101	—	A18846-2001	—	85.22	76.70
24" x 30"	—	A18846-1013	A18846-8013	A18846-9413	A18846-5013	A18846-5113	A18846-9313	A18846-2013	A18846-9113	106.17	95.55
24" x 36"	—	A18846-1015	A18846-8015	—	A18846-5015	—	A18846-9315	A18846-2015	—	117.61	105.85

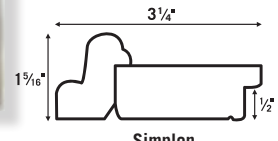

NIELSEN BAINBRIDGE™

Nielsen Bainbridge™ Snap™ Gallery Frames

When a simple wood frame is all that's required to show off your artwork and photographs, Snap Gallery Frames are a great option. Every frame includes a white mat and a glass face. Frames 8" x 10" and smaller also include an easel back. Frame a favorite piece of artwork to make a statement — or several to create a stunning wall display. Can be hung horizontally or vertically.

Single Opening

FRAME SIZE	OPENING SIZE	BLACK	GREY	WHITE	EACH	6/EA
6" x 8"	4" x 6"	A18737-2021	A18737-2501	A18737-1021	\$8.56	\$7.68
8" x 10"	5" x 7"	A18737-2022	A18737-2502	A18737-1022	11.03	9.93
11" x 14"	8" x 10"	A18737-2025	A18737-2505	A18737-1025	14.70	13.23
16" x 20"	11" x 14"	A18737-2028	A18737-1028	—	26.98	24.29

Double Opening

FRAME SIZE	OPENING SIZE	BLACK	GREY	WHITE	EACH	6/EA
11" x 14"	5" x 7"	A18737-2035	—	—	\$14.70	\$13.23



Nielsen Bainbridge™ Snap™ Wood Digital Format Frames

Use these sleek and simple black frames to complement your digital photos, artwork, and more. Available in a variety of popular digital format sizes, these wood frames have a black backing and fast-tab closure, making assembly a snap. Use the included D-ring hangers to display your artwork vertically or horizontally, individually or in groups.

NUMBER	SIZE	EACH	4/EA
A17559-2022	8" x 12"	\$12.49	\$11.24
A17559-2025	8-1/2" x 14"	15.11	13.74
A17559-2023	9" x 12"	15.85	14.26
A17559-2020	10" x 20"	17.34	17.16
A17559-2027	11" x 17"	17.04	15.34
A17559-2026	12" x 16"	19.30	17.37
A17559-2028	12" x 18"	19.32	17.39
A17559-2029	13" x 19"	19.29	17.37



Nielsen Bainbridge™ EcoCare™ Frames

EcoCare is as committed to environmental sustainability as it is to design aesthetics. These frames are made from sustainable wood alternatives and reclaimed plantation woods, which do not contribute to deforestation. All elements are either recyclable or biodegradable, and the frame finish is waterbased and free of chemicals and solvents. Each frame (except for the 5" x 7" digital size) includes an acid-free mat. The 5" x 7" and 8" x 10" frames have an easel back.

Natural Bamboo				Mocha Bamboo			
NUMBER	SIZE	EACH	4/EA	NUMBER	SIZE	EACH	4/EA
A18877-1910	5" x 7"	\$15.24	\$13.71	A18877-8370	5" x 7"	\$15.24	\$13.71
A18877-1912	8" x 10"	25.47	22.93	A18877-8372	8" x 10"	25.47	22.93
A18877-1915	11" x 14"	30.56	27.49	A18877-8375	11" x 14"	30.56	27.49
A18877-1918	16" x 20"	43.87	39.49	A18877-8378	16" x 20"	43.87	39.49

Black Rubber Tree				Digital Format Black Rubber Tree			
NUMBER	SIZE	EACH	4/EA	NUMBER	SIZE	EACH	4/EA
A18877-2020	5" x 7"	\$12.95	\$11.65	A18877-2021	8-1/2" x 11"	\$17.84	\$16.06
A18877-2022	8" x 10"	22.07	19.87	A18877-2023	9" x 12"	21.41	19.27
A18877-2025	11" x 14"	27.34	24.60	A18877-2027	11" x 17"	28.55	25.70
A18877-2028	16" x 20"	38.75	34.88	A18877-2026	12" x 18"	29.98	26.99
				A18877-2029	13" x 19"	32.12	28.91



Nielsen Bainbridge™ Snap™ Display Easels

These compact, stylish easels are perfect for displaying photos or small works of art. Available in a variety of styles, Nielsen Bainbridge Snap Display Easels can be used alone or in groups on any horizontal surface, including desks, end tables, bookcases, and more.

NUMBER	DESCRIPTION	SIZE	EACH	4/EA
A50587-8006	Black Metal, Knotted	6"	\$8.58	\$7.73
A50587-2029	Black Chair	9"	6.60	5.94
A50587-2020	Black Wood, Hinged	10"	13.74	12.37
A50587-1014	Round Top Scallop	14"	17.18	15.46

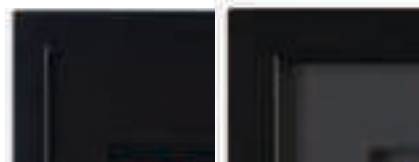

Black w/ Black Mat Black w/ White Mat



Graywash w/ White Mat White w/ White Mat

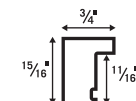

Nielsen Bainbridge™ Gallery Solutions™ Airfloat Wood Frames

Add depth and dimension to your artwork with this wide wood frame featuring a contemporary design. Two mats are separated by spacers to create a floating effect. Frame can be hung vertically or horizontally and includes a "wall grabber" hanger that makes leveling easy. Each frame comes with a Plexiglas glazing. Easel back is on 8" x 10" size only.

SIZE	ARTWORK SIZE	BLACK W/ BLACK MAT	BLACK W/ WHITE MAT	ESPRESSO W/ WHITE MAT	GRAYWASH W/ WHITE MAT	WHITE W/ WHITE MAT	EACH	4/EA
8" x 10"	5" x 7"	A18701-2022	A18701-2052	A18701-8002	A18701-1002	A18701-1022	\$27.84	\$25.06
11" x 14"	8" x 10"	A18701-2025	A18701-2055	A18701-8005	A18701-1005	A18701-1025	42.34	38.11
14" x 18"	11" x 14"	A18701-2027	A18701-2017	A18701-8005	A18701-1007	A18701-1027	52.34	47.10



Espresso w/ White Mat



MCS™ Clip Frames

When you want your photos to speak for themselves, MCS Euro Clip Frames are a great option. Ideal for minimalist, contemporary presentations in homes, galleries, offices, and more, these frames show your entire photo from edge-to-edge. Sturdy chrome clips hold the glass face to the masonite backing, which has white painted edges for a seamless look. The glass face has polished edges and the hanging hardware is pre-mounted for vertical or horizontal display.

NUMBER	SIZE	EACH	4/EA
A18962-1011	4" x 6"	\$3.98	\$3.58
A18962-1000	5" x 7"	5.72	5.15
A18962-1012	8" x 10"	7.45	6.71
A18962-1010	8 1/2" x 11"	8.20	7.39
A18962-1023	9" x 12"	8.73	7.86
A18962-1005	11" x 14"	12.71	11.44
A18962-1006	12" x 16"	13.74	12.37
A18962-1008	16" x 20"	19.82	17.84
A18962-1009	18" x 24"	26.84	24.16



MCS™ Brushed Aluminum Frames

These beautiful aluminum wall frames feature a brushed cross-hatch design that is elegant yet understated. Available in a variety of finishes, each has a 9/16" profile and includes a bevel-cut white mat, a glass face, and turnbuckles for easy access and a secure fit for your photos and artwork. 11/16" deep. 3/8" rabbet.

FRAME SIZE	OPENING SIZE	GOLD	GUNMETAL	SILVER	EACH	4/EA
8" x 10"	5" x 7"	A17386-8162	A17386-2612	A17386-9332	\$20.22	\$18.19
8-1/2" x 11"	—	A17386-8161	A17386-2611	A17386-9331	22.47	20.23
11" x 14"	8" x 10"	A17386-8165	A17386-2615	A17386-9335	30.94	27.84
16" x 20"	11" x 14"	A17386-8168	A17386-2618	A17386-9348	45.39	40.86

FRAME SIZE	OPENING SIZE	GOLD	GUNMETAL	SILVER	EACH	4/EA
10" x 20"	5" x 7"	A17386-8167	A17386-2617	A17386-9337	\$34.39	\$30.94



poster frames



Single Panel, Silver



Wexel Art™ Changeable Display Frames

Easy to hang and easy to use, these innovative frames employ "Impressively Strong Magnets" to hold photos, artwork, signs, or your favorite memorabilia without the hassle of custom framing. Their true beauty lies in the floating acrylic panel that works with the magnets to hold your art in place, allowing you to seamlessly change your displays in seconds. The single panel frames allow art in a range of sizes to be displayed, plus 3-D art and unusually shaped art. 12-month manufacturer's warranty.

Single Panel Silver			
NUMBER	FRAME SIZE	ARTWORK SIZE	EACH
A18717-1012	10" x 12"	8-1/2" x 11"	\$44.09
A18717-1014	14" x 14"	12" x 12"	60.62
A18717-1019	14" x 19"	11" x 17"	71.65
A18717-1028	19" x 23"	16" x 20"	110.23
A18717-1029	21" x 27"	18" x 24"	143.30
A18717-1215	27" x 39"	24" x 36"	253.54

Double Panel Silver			
NUMBER	FRAME SIZE	ARTWORK SIZE	EACH
A18717-1110	10" x 12"	5" x 7"	\$60.62
A18717-1112	12" x 15"	9" x 12"	66.13
A18717-1115	15" x 15"	12" x 12"	77.16
A18717-1118	15" x 18"	11" x 14"	88.18
A18717-1038	19" x 23"	16" x 20"	132.28
A18717-1039	21" x 27"	18" x 24"	165.35
A18717-1127	23" x 27"	20" x 24"	198.42
A18717-1133	23" x 27"	20" x 30"	231.49
A18717-1315	28" x 40"	24" x 36"	297.64



Double Panel, Silver

Single Panel, Gold

Single Panel Gold			
NUMBER	FRAME SIZE	ARTWORK SIZE	EACH
A18717-9012	12" x 14"	8" x 10"	\$55.11
A18717-9014	14" x 14"	12" x 12"	60.62
A18717-9019	14" x 19"	11" x 17"	71.65
A18717-9013	19" x 23"	16" x 20"	109.13

Impressively Strong Magnets for Hanging Artwork — 8 per pack.

NUMBER	EACH
A18717-1008	\$15.42

For more Wexel frames, visit DickBlick.com.



MCS™ Format Frames

The black Format Frame is perfect for certificates, diplomas, awards, photos, and artwork. Mount it on a wall or place it on a tabletop, depending on your preference. The Format Frame can be displayed either vertically or horizontally.

NUMBER	SIZE	EACH	6/EA
A17038-1000	5" x 7"	\$3.76	\$3.39
A17038-1012	8" x 10"	4.47	4.03
A17038-1032	8-1/2" x 11"	6.24	5.62
A17038-1005	11" x 14"	8.26	7.43
A17038-1008	16" x 20"	14.40	12.96



MCS™ Clear Box Frames

These clear, molded acrylic frames have a rigid white cardboard insert to keep your artwork pressed firmly against the face. Can be hung vertically or horizontally. The 4" x 6", 5" x 7", and 8" x 10" sizes have easel backs for standing.

NUMBER	SIZE	EACH	6/EA
A17007-1900	4" x 6"	\$3.30	\$2.97
A17007-1901	5" x 7"	3.52	3.17
A17007-1902	8" x 10"	5.72	5.15
A17007-1932	8-1/2" x 11"	7.59	6.83
A17007-1905	11" x 14"	10.24	9.22
A17007-1908	16" x 20"	21.70	19.53
A17007-1909	18" x 24"	29.98	26.98



Nielsen Bainbridge™ Snap™ Artwork Storage Frame

Great for displaying a child's artwork, this simple-to-use wood frame has a unique hinged front with a magnetic closure for ease of changing, storing, or rearranging items. The 13" x 16" x 1-1/4"D frame includes a beveled white mat with a 9" x 12" opening, a glass face, and attached sawtooth hangers so you can change from vertical to horizontal display in a snap! Inside, two elastic bands hold your stored artwork in place.

NUMBER	EACH	4/EA
A17562-1020	\$36.20	\$32.58



A Nielsen Bainbridge™ Tribeca Poster Frames

These wood poster frames feature an elegant black finish, straight-line profile, and 1-1/4" depth, making them ideal for showcasing posters or contemporary artwork. A glass face and mounting hardware for horizontal or vertical hanging are included.

NUMBER	SIZE	EACH	4/EA
A18833-2029	18" x 24"	\$53.99	\$48.59
A18833-2020	20" x 24"	60.97	54.86
A18833-2022	22" x 28"	69.68	62.70
A18833-2025	24" x 36"	86.41	77.77

D Leader™ Frames

Remove pictures, certificates, posters, documents, or other pieces from this frame in seconds, without tools. The patented swivel clip requires a simple push and turn to activate and sits flush to the wall when mounted. Non-glare, acrylic front is UV-protected, lightweight, and shatter-resistant.

NUMBER	COLOR	SIZE	EACH	3/EA
A17021-2009	Black	18" x 24"	\$58.42	\$52.58
A17021-2011	Black	22" x 28"	68.72	61.85
A17021-9309	Silver	18" x 24"	58.42	52.58
A17021-9311	Silver	22" x 28"	68.72	61.85



B MCS™ Large Format Poster Frames

These durable, black, all-acrylic frames have mitered corners, a clear protective front sheet, a masonite backing for mounting, and a hanging system for vertical or horizontal display. No assembly required.

NUMBER	SIZE	EACH	6/EA
A18806-2028	16" x 20"	\$13.69	\$12.32
A18806-2029	18" x 24"	15.05	13.55
A18806-2022	22" x 28"	23.69	21.32
A18806-2025	24" x 36"	28.39	25.55

E MCS™ Framatic™ Super Simple Poster Frames

Framing a poster has never been simpler! These frames are easy to use because of a patented FRAMLOK joining system. Very light and nearly unbreakable, the anodized aluminum frames come in a variety of sizes and two color options. The .040" thick styrene face is covered with a protective film that should be removed after assembly — and before hanging. The 8" x 10" and 11" x 14" frames also include an easel stand.

NUMBER	SIZE	EACH	6/EA
A17389-1009	16" x 20"	\$23.55	\$21.19
A17389-1010	18" x 24"	25.21	22.69
A17389-1011	20" x 24"	31.78	28.60
A17389-1012	20" x 28"	33.06	29.75
A17389-1013	20" x 30"	36.03	32.43
A17389-1014	22" x 28"	36.03	32.43
A17389-1015	24" x 30"	38.03	34.23
A17389-1016	24" x 36"	43.31	38.98



C Nielsen Bainbridge™ Snap™ Poster Frames

These easy-to-use frames are perfect for displaying your favorite movie posters, artwork, photos, and collages. Made of durable, lightweight plastic, it includes a sturdy MDF backing board and an ultra-lightweight Plexiglas face.

NUMBER	SIZE	EACH	4/EA
A17376-2028	16" x 20"	\$11.52	\$10.37
A17376-2029	18" x 24"	13.06	11.75
A17376-2023	20" x 30"	17.67	15.90
A17376-2022	22" x 28"	19.97	17.98
A17376-2025	24" x 36"	28.43	25.59

F MCS™ Trendsetter Acrylic Poster Frames

Protect and display your favorite posters in this durable, gloss black-finished frame with a 1" wide face. Includes corrugated backing. Composite material construction.

NUMBER	SIZE	EACH	6/EA
A18819-2018	16" x 20"	\$21.58	\$19.42
A18819-2019	18" x 24"	25.79	23.21
A18819-2012	22" x 28"	32.29	29.06
A18819-2015	24" x 36"	36.51	32.86

FRAME KITS CREATE ANY SIZE FRAME

1 FIND YOUR STYLE



2 FIND YOUR 2 SIZES



3 ASSEMBLE IT



- Easily build a frame to fit your artwork or photography
- No cutting or cropping needed
- Hardware included
- Sold in pairs
- Two kits make one frame

NIELSEN™

There is no name in metal frames more respected than Nielsen. Blick offers six profiles in 17 colors! Each style is available in even-inch increments from 6" to 42". Order in pairs of equal length, two pairs completing a frame. Each order is shipped with all the hardware needed to easily build a beautiful and sturdy frame. All you need is a flat-head screwdriver. To order, follow the instructions below.

1 Choose a Frame Style from the profile cross-sections shown below. An order number appears in Section 1 of this chart when a color is available in that specific style. Choose a color. Color samples are shown at left. The order numbers in Section 1 are incomplete until you add the size reference to the end. Proceed to section 2 below.



	STYLE 11	STYLE 15	STYLE 93	STYLE 97	STYLE 22	STYLE 117
STYLE & COLOR NUMBER	NUMBER	NUMBER	NUMBER	NUMBER	NUMBER	NUMBER
Frosted Silver	A17408-97XX	A17409-97XX	—	—	A17410-97XX	A17427-97XX
German Silver	A17408-27XX	A17409-27XX	A17411-27XX	—	A17410-27XX	A17427-27XX
Florentine Silver	A17408-95XX	A17409-95XX	A17411-95XX	A17412-95XX	—	—
Frosted Pewter	A17408-26XX	A17409-26XX	—	—	—	A17427-26XX
Florentine Grey	A17408-25XX	A17409-25XX	A17411-25XX	A17412-25XX	—	—
Graphite	A17408-23XX	A17409-23XX	A17411-23XX	—	—	A17427-23XX
Contrast Grey	—	A17409-24XX	—	—	—	—
Gold	A17408-90XX	A17409-90XX	—	—	A17410-90XX	—
Frosted Gold	A17408-93XX	A17409-93XX	—	—	—	A17427-93XX
Florentine Gold	—	A17409-92XX	—	A17412-92XX	—	—
Antique Gold	A17408-91XX	A17409-91XX	—	—	—	A17427-91XX
Bright White	—	—	A17411-10XX	—	—	A17427-10XX
Florentine Black	A17408-21XX	A17409-21XX	A17411-21XX	A17412-21XX	—	—
Matte Black	A17408-22XX	A17409-22XX	A17411-22XX	A17412-22XX	A17410-22XX	A17427-22XX
Anodic Black	A17408-20XX	A17409-20XX	A17411-20XX	—	—	A17427-20XX
Frosted Walnut	—	A17409-89XX	A17411-89XX	—	—	A17427-89XX
Frosted Umber	—	A17409-85XX	—	—	—	—

2 Select a Size from this list. The size becomes the last two digits for your order number. For example: a 6" pair of style 11 in Anodic Black would be ordered as A17408-2006. Find your price in the chart. Order two pairs to complete your frame.

SIZE	STYLE 11		STYLE 15		STYLE 93		STYLE 97		STYLE 22		STYLE 117	
	EACH	4/EA	EACH	4/EA	EACH	4/EA	EACH	4/EA	EACH	4/EA	EACH	4/EA
6"	\$6.50	\$5.85	\$7.29	\$6.56	\$7.30	\$6.57	\$13.22	\$11.90	\$8.20	\$7.38	\$8.20	\$7.38
7"	7.38	6.64	7.97	7.17	8.51	7.66	14.18	12.76	10.23	9.21	10.23	9.21
8"	9.99	8.98	9.53	8.58	9.50	8.55	15.42	13.88	11.40	10.26	11.40	10.26
9"	10.79	9.71	10.48	9.43	10.50	9.45	16.49	14.84	12.61	11.35	12.61	11.35
10"	12.08	10.87	11.69	10.52	11.65	10.48	17.71	15.94	13.99	12.59	13.99	12.59
11"	13.22	11.90	12.76	11.48	12.69	11.42	19.77	17.79	15.22	13.70	15.22	13.70
12"	13.67	12.30	13.77	12.39	13.67	12.30	20.99	18.89	16.41	14.77	16.41	14.77
13"	13.98	12.58	14.83	13.35	14.87	13.38	22.04	19.84	17.85	16.06	17.85	16.06
14"	14.94	13.45	15.51	13.96	15.88	14.29	23.06	20.75	19.05	17.14	19.05	17.14
15"	16.26	14.63	17.80	15.99	17.06	15.35	24.30	21.87	20.46	18.41	20.46	18.41
16"	18.22	16.40	18.37	16.53	17.99	16.19	25.34	22.81	21.65	19.48	21.65	19.48
17"	18.44	16.60	19.39	17.45	19.04	17.14	26.37	23.73	22.81	21.46	22.81	21.46
18"	19.48	17.53	20.52	18.47	20.24	18.22	27.61	24.85	24.28	21.85	24.28	21.85
19"	20.70	18.63	21.78	19.60	21.19	19.07	28.61	25.75	25.43	22.89	25.43	22.89
20"	22.68	20.41	21.97	19.77	22.21	19.99	30.90	27.81	26.65	23.98	26.65	23.98
21"	22.68	20.41	23.40	21.06	23.40	21.06	31.93	28.74	28.08	25.27	28.08	25.27
22"	23.96	21.56	24.41	21.97	24.41	21.97	32.99	29.69	29.29	26.36	29.29	26.36
23"	26.11	23.50	25.40	22.86	25.40	22.86	35.22	31.70	30.48	27.43	30.48	27.43
24"	26.21	23.59	26.58	23.92	26.58	23.92	37.47	33.72	31.92	28.73	31.92	28.73
25"	27.23	24.51	27.55	24.79	27.55	24.79	39.76	35.78	33.06	29.75	33.06	29.75
26"	28.22	25.40	28.51	25.66	28.51	25.66	41.83	37.65	34.23	30.81	34.23	30.81
27"	29.22	26.30	29.75	26.77	29.75	26.77	43.06	38.75	35.71	32.14	35.71	32.14
28"	30.46	27.41	30.73	27.66	30.73	27.66	44.09	39.68	36.89	33.20	36.89	33.20
29"	31.46	28.31	31.76	28.58	31.76	28.58	45.13	40.62	38.12	34.31	38.12	34.31
30"	32.50	29.25	32.94	29.65	32.94	29.65	46.36	41.72	39.52	35.57	39.52	35.57
31"	33.72	30.35	33.91	30.52	33.91	30.52	47.39	42.65	40.70	36.63	40.70	36.63
32"	34.73	31.26	34.94	31.45	34.94	31.45	48.43	43.59	41.88	37.69	41.88	37.69
33"	35.75	32.17	36.12	32.51	36.12	32.51	49.65	44.68	43.33	38.99	43.33	38.99
34"	36.96	33.26	37.09	33.38	37.09	33.38	50.70	45.63	44.49	40.04	44.49	40.04
35"	37.96	34.16	38.29	34.46	38.29	34.46	52.95	47.65	45.95	41.35	45.95	41.35
36"	39.19	35.27	39.29	35.36	39.29	35.36	54.99	50.49	47.16	42.44	47.16	42.44
37"	40.22	36.20	40.27	36.24	40.27	36.24	56.21	50.59	48.34	43.51	48.34	43.51
38"	41.22	37.10	41.47	37.32	41.46	37.32	57.29	51.56	49.77	44.79	49.77	44.79
39"	42.39	38.15	42.46	38.21	42.46	38.21	59.52	53.57	50.95	45.85	50.95	45.85
40"	43.45	39.10	43.45	39.10	43.45	39.10	61.82	55.64	52.15	46.93	52.15	46.93
41"	44.47	39.99	44.66	40.19	44.66	40.19	63.89	57.50	53.58	48.22	53.58	48.22
42"	45.64	41.08	45.64	41.08	45.64	41.08	66.13	59.52	54.77	49.29	54.77	49.29

Nielsen™ Metal Frame Kits

Achieve the look of a custom frame for a fraction of the price! Customize artwork, photographs, and more to nearly any full inch size from 8" to 40". These aluminum mouldings are the same quality utilized by custom picture framers and are easy to assemble. The face is 5/16" with a depth of 7/16", which holds a print, backing glass, and up to two mats. Simply measure the overall height and width from the outside edges of your work. Choose one size kit for length and one size for width and assemble your frame with the included hardware. Two kits make one frame.

SIZE	SILVER		BLACK	
	EACH	4/EA	EACH	4/EA
8"	A17417-9308	A17417-2008	\$11.45	\$10.30
9"	A17417-9309	A17417-2009	12.03	10.83
10"	A17417-9310	A17417-2010	12.44	11.20
11"	A17417-9311	A17417-2011	12.87	11.58
12"	A17417-9312	A17417-2012	13.15	11.83
13"	A17417-9313	A17417-2013	13.57	12.21
14"	A17417-9314	A17417-2014	13.99	12.59
15"	A17417-9315	A17417-2015	14.58	13.12
16"	A17417-9316	A17417-2016	14.83	13.35
17"	A17417-9317	A17417-2017	15.41	13.87
18"	A17417-9318	A17417-2018	15.93	14.34
19"	A17417-2419	A17417-2019	16.42	14.78
20"	A17417-9320	A17417-2020	16.83	15.15
21"	A17417-9321	A17417-2021	17.24	15.52
22"	A17417-9322	A17417-2022	17.54	15.79
23"	A17417-9323	A17417-2023	17.83	16.05
24"	A17417-9324	A17417-2024	18.39	16.55
25"	A17417-9325	A17417-2025	18.80	16.92
26"	A17417-9326	A17417-2026	19.80	17.82
27"	A17417-2427	A17417-2027	20.22	18.20
28"	A17417-9328	A17417-2028	20.94	18.85
29"	A17417-9329	A17417-2029	21.19	19.07
30"	A17417-9330	A17417-2030	22.04	19.84
32"	A17417-9332	A17417-2032	22.82	20.54
33"	A17417-2433	A17417-2033	23.18	20.86
34"	A17417-2434	A17417-2034	23.28	20.95
35"	A17417-2435	A17417-2035	24.17	21.76
36"	A17417-9336	A17417-2036	24.57	22.12
39"	A17417-2439	A17417-2039	25.97	23.38
40"	A17417-9340	A17417-2040	26.59	23.94

Nielsen Bainbridge™ Ayous Wood Section Frames

Now it's easy to complement your artwork with the look of a custom wood frame. Designed with a contemporary flat-top profile for an attractive gallery look, these frames are the perfect depth for framing canvas, photographs, posters, or other artwork. Each kit includes one pair of wood sections and two plastic wedges. Two kits make one frame. Easy to assemble; no tools required.

SIZE	BLACK		NATURAL	
	EACH	6/EA	EACH	6/EA
8"	A17416-2008	A17416-1908	\$14.14	\$12.73
9"	A17416-2009	A17416-1909	15.98	14.38
10"	A17416-2010	A17416-1910	16.15	14.53
11"	A17416-2011	A17416-1911	17.41	15.67
12"	A17416-2012	A17416-1912	17.82	16.04
13"	A17416-2013	A17416-1913	18.44	16.60
14"	A17416-2014	A17416-1914	19.13	17.22
15"	A17416-2015	A17416-1915	19.65	17.68
16"	A17416-2016	A17416-1916	20.70	18.63
17"	A17416-2017	A17416-1917	20.94	18.85
18"	A17416-2018	A17416-1918	22.68	20.41
20"	A17416-2020	A17416-1920	23.99	21.59
22"	A17416-2022	A17416-1922	25.30	22.77
24"	A17416-2024	A17416-1924	27.09	24.38
26"	A17416-2026	A17416-1926	34.84	31.36
28"	A17416-2028	A17416-1928	36.03	32.43
30"	A17416-2030	A17416-1930	36.37	32.73
32"	A17416-2032	A17416-1932	41.55	37.39
36"	A17416-2036	A17416-1936	44.25	39.83
40"	A17416-2040	A17416-1940	46.09	41.48

Wedges may be glued in for more stability.

See Page 548 for wood glue.

BLICK® wood frames

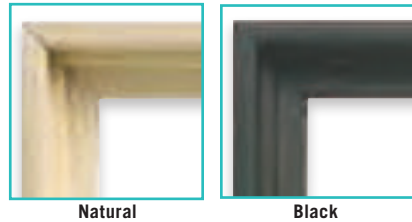

Blick® Maplewood Floater Frames

Available in a variety of popular sizes to accommodate 3/4" deep or 7/8" deep canvases, these frames are made from genuine American maple hardwood. Every frame is hand-rubbed, giving it a silky smooth feel and a "washed" appearance, which may be more pronounced with the Black frame. Frame color may vary slightly depending on the color of the natural wood.

5/16" Width — For 3/4" or 7/8" Deep Canvas

SIZE	NATURAL	BLACK STAIN	EACH	10/EA
8" x 10"	A18898-1912	A18898-2022	\$23.52	\$21.17
9" x 12"	A18898-1923	A18898-2023	24.83	22.35
11" x 14"	A18898-1905	A18898-2025	30.24	27.22
12" x 16"	A18898-1906	A18898-2026	32.91	29.62
16" x 20"	A18898-1908	A18898-2028	36.90	33.21
18" x 24"	A18898-1909	A18898-2029	42.99	38.69

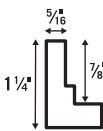

Black



Natural

Paint!
Stain!
Decorate!



Blick® Wood Gallery Open Back Frames

Made from poplar wood with a black finish, these frames have clean lines and an open back for accommodating canvases and panels up to 3/4" deep. Made in the USA. Note: Does not include hanging hardware.



NUMBER	SIZE	EACH	12/EA
A18722-1001	5" x 7"	\$18.38	\$16.54
A18722-1002	6" x 6"	18.38	16.54
A18722-1003	8" x 8"	29.39	26.45
A18722-1004	8" x 10"	31.20	28.08
A18722-1005	9" x 12"	27.35	24.62
A18722-1006	10" x 10"	35.63	32.07
A18722-1007	11" x 14"	33.30	29.97
A18722-1008	12" x 12"	36.74	33.07
A18722-1009	12" x 16"	40.42	36.38
A18722-1010	16" x 20"	45.32	40.79
A18722-1011	18" x 24"	61.50	55.35

Front



Back



Mini Wood Frames

These unfinished 5" x 5" wood frames with a 3" x 3" opening are a great size for class projects, and economical enough so everyone can share in the fun. Stain them, paint them, decorate them!

NUMBER	DESCRIPTION	EACH	12/EA
A18218-1033	#832 Silver	\$2.52	\$2.27

HEALTH & SAFETY ICONS: ●=CL / ■=Prop 65 / ▼=CL & Prop 65
See page 644 for more information.



Mona Lisa™ Composition Gold Leaf Kit

Achieve the look of real gold at an affordable price. This kit includes enough leaf to cover the surface of a lamp, frame, figurine, or any number of other projects. Includes 25 sheets of composition gold leaf (5-1/2" x 5-1/2"), a 2 oz jar of adhesive, and a 2 oz jar of sealer.

NUMBER	EACH	12/EA
A27001-4059	\$17.35	\$15.61



Mona Lisa™ Simple Leaf™

Makes leafing a breeze! This transfer-style leaf is easier to handle and apply than traditional leaf, but achieves the same lustrous results. Just place it on an adhesive surface and peel back the transfer paper — no waste or mess! Can be combined with regular leaf. Package includes 18, 5-1/2" x 5-1/2" sheets and basic instructions.

NUMBER	COLOR	EACH	12/EA
A27021-8110	Copper	\$10.65	\$9.58
A27021-2070	Gold	10.65	9.58
A27021-2590	Silver	10.65	9.58



Old World Art™ Leafing Kits

Use the same materials employed by professionals around the world as you learn the art of leafing using silver or copper. Both kits contain a variety of basic materials, including a 2 oz (59 ml) bottle each of Adhesive Size and Satin Sealer, two brushes, a burnishing cloth, and a book of leafing material.

#832 Composition Silver Leafing Kit — Contains the basic materials listed above, plus one book of Composition Silver Leaf.

NUMBER	DESCRIPTION	EACH	12/EA
A27013-2409	#832 Silver	\$31.41	\$28.27

#833 Copper Leaf Kit — Contains the basic materials listed above, plus one book of Copper Leaf.

NUMBER	DESCRIPTION	EACH	12/EA
A27013-8119	#833 Copper	\$31.41	\$28.27

WARNING! Products marked with a Prop 65 symbol (■ or ▼) can expose you to chemicals, including cadmium, which are known to the State of California to cause cancer and birth defects or other reproductive harm. For more information, visit P65Warnings.ca.gov.

gold leafing process



Step 1: Apply a basecoat to seal the surface. When dry, apply adhesive, taking care not to leave brush marks.



Step 2: While the adhesive is still tacky, apply gold leaf, following package instructions.



Step 3: Buff the surface of the frame to ensure adhesion.



Step 4: Brush on sealer to protect the finish from possible abrasions in the future.



Mona Lisa™ Imitation Gold and Silver Leaf

Not recommended for outdoor use, this imitation gold and silver leaf will tarnish or oxidize unless sealed with varnish. Book contains 25, 5-1/2" x 5-1/2" leaves.

Gold — Looks and feels like genuine gold leaf.

NUMBER	COLOR	EACH	12/EA
A27012-4010	Gold	\$11.64	\$10.48

Silver — Aluminum metal looks like real silver.

NUMBER	COLOR	EACH	12/EA
A27012-2050	Silver	\$11.11	\$9.99



Monastery™ Gold Leaf

Create stunning works of art with genuine, non-tarnishing gold leaf. Packaged in loose sheets and separated with thin sheets of rouged paper, each 3-3/8" x 3-3/8" sheet can be easily removed without disturbing the others. 25 sheets per book.

NUMBER	COLOR	KARAT WT.	EACH	20/EA
A27014-7151	White Gold	12K	\$49.20	\$44.27
A27014-7158	Yellow Gold	18K	75.62	68.05
A27014-7152	Yellow Gold	22K	81.14	72.99
A27014-7154	Yellow Gold	23.75K	87.54	78.78

For more leaf, adhesive, and seals, visit DickBlick.com.

Amaco® Rub 'n Buff™ Metallic Finishes

Use Amaco Rub 'n Buff for decorating and antiquing wood, plaster, pottery, metal, leather, and gessoed surfaces. Just rub on the creamy paste and buff to a beautiful luster. Formulated from carnauba waxes, fine metallic powders, and select pigments, these wax metallic finishes lend a finish no paint can duplicate — great for enhancing home décor items, frames, costumes, craft projects, and more. Each 0.5 oz tube will cover up to 20 square feet. For hard-to-reach areas, thin with turpentine and apply with a brush. Colors can be blended.

NUMBER	COLOR	EACH	12/EA
A27102-4571	Antique Gold	\$8.65	\$7.79
A27102-4591	Autumn Gold	8.65	7.79
A27102-2241	Ebony	8.65	7.79
A27102-4911	European Gold	8.65	7.79
A27102-5011	Gold Leaf	8.65	7.79
A27102-5121	Grecian Gold	8.65	7.79
A27102-2581	Pewter	8.65	7.79
A27102-2590	Silver Leaf	8.65	7.79
A27102-8911	Spanish Copper	8.65	7.79

Old World Art™ Satin Sealer

Brush-on Satin Sealer protects leafing from wear and tarnishing. Clean with mineral spirits.

NUMBER	EACH	12/EA
A27013-1102	\$6.15	\$5.53



Glass and Backing

Our most economical choice for the do-it-yourself framer, or for replacing glass that is scratched or broken. Available in six popular frame sizes, each set includes a 1/16" thick piece of glass and a heavyweight cardboard backing board. The glass edges are ground smooth for ease of handling.

NUMBER	SIZE	EACH	6/EA
A18978-1000	5" x 7"	\$3.37	\$3.03
A18978-1012	8" x 10"	4.91	4.42
A18978-1085	8-1/2" x 11"	5.03	4.51
A18978-1005	11" x 14"	7.17	6.45
A18978-1006	12" x 16"	8.40	7.56
A18978-1008	16" x 20"	9.42	8.48



Nielsen Bainbridge™ Non-Glare Styrene Sheets

A popular alternative to glass when framing artwork, these pre-cut, 0.050" thick polystyrene sheets reduce glare, reflections, and UV damage. Less fragile than glass, they're also great for shipping artwork.

NUMBER	SIZE	EACH	12/EA
A17361-1000	5" x 7"	\$2.46	\$2.21
A17361-1012	8" x 10"	5.26	4.73
A17361-1023	9" x 12"	6.72	6.04
A17361-1005	11" x 14"	7.28	6.54
A17361-1006	12" x 16"	12.89	11.59
A17361-1008	16" x 20"	13.45	12.09
A17361-1009	18" x 24"	15.69	14.11
A17361-1001	20" x 24"	17.38	15.62
A17361-1015	24" x 36"	39.25	35.28



Clear Acrylic Sheets for Framing

An alternative to fragile glass. Pre-cut, ideally sized sheets of 0.060" thick acrylic plastic have a non-glare finish on one side.

NUMBER	SIZE	EACH	12/EA
A18973-1005	5" x 7"	\$2.35	\$2.12
A18973-1008	8" x 10"	5.03	4.51
A18973-1009	9" x 12"	6.74	6.07
A18973-1011	11" x 14"	7.48	6.74
A18973-1012	12" x 16"	12.34	11.11
A18973-1014	14" x 18"	17.18	15.47
A18973-1016	16" x 20"	15.22	13.70
A18973-1018	18" x 24"	16.12	14.51
A18973-1020	20" x 24"	20.20	18.19
A18973-1024	24" x 36"	41.99	37.81



3M™ Command™ Picture Hanging Strips

No more nail holes, cracked plaster, or sticky residue. Command Picture Hanging Strips make decorating quick and easy. One click tells you the strips are locked in and holding tight. Best of all, when you're ready to reposition or remove your pictures, the strips remove cleanly. The small strips hold most 8" x 10" frames, the medium strips hold most 18" x 24" frames, and the large strips hold most 24" x 36" frames.

NUMBER	DESCRIPTION	EACH	12/EA
A57324-1010	Small, 8-pack	\$5.04	\$4.53
A17345-1004	Large, 6-pack	7.53	6.78
A17345-1001	Narrow, 8-pack	4.97	4.47

Value Pack — Includes eight Medium and 16 Large.
 NUMBER EACH 12/EA
 A17345-1005 \$11.28 \$10.15



3M™ Command™ Adhesive Poster Strips

Turn a blank wall into a personal art gallery with adhesive poster strips from 3M. Simply press and stick the strip to a flat, smooth surface, then step back and enjoy the view. When it's time for a new look, just gently stretch the adhesive to remove the strip cleanly. No sticky, oily residue is left behind!

NUMBER	DESCRIPTION	EACH	12/EA
A24920-1001	12-pack	\$3.03	\$2.73
A24131-9060	60-pack	11.29	10.16



OOK™ Picture Hook Kit

Includes 10 picture hooks for hanging 10–50 lb, two sawtooth hangers, 30 lb picture wire, 20 screw eyes, and 17 nails.

NUMBER	EACH	12/EA
A18988-1009	\$3.82	\$3.44



A-F OOK™ Picture Hanging Hardware

Hang your pictures with hardware from OOK.

A Pro Picture Value Pack — Used by museums and art galleries, OOK's padded hangers won't damage your walls. Contains 12 assorted OOK padded hangers with hanging capacities from 10–100 lb.

NUMBER	EACH	12/EA
A18986-1009	\$10.92	\$9.83

B Padded Pro Picture Hangers

NUMBER	DESCRIPTION	EACH	12/EA
A18987-1010	10 lb capacity, pkg of 4	\$3.62	\$3.26
A18987-1020	20 lb capacity, pkg of 3	3.62	3.26
A18987-1030	30 lb capacity, pkg of 3	3.62	3.26
A18986-1030	30 lb capacity, pkg of 10	8.93	8.04
A18987-1050	50 lb capacity, pkg of 2	3.62	3.26
A18986-1050	50 lb capacity, pkg of 10	8.93	8.04

C ReadyNail Sawtooth Hangers

NUMBER	DESCRIPTION	EACH	12/EA
A18984-1010	Small, pkg of 3	\$3.86	\$3.48
A18984-1020	Large, pkg of 2	3.86	3.48

D D-Ring Hangers — For hanging canvases and lightweight frames. Fitted with a special collar that holds the screw in place for easy installation.

NUMBER	DESCRIPTION	EACH	6/EA	12/EA
A18981-2003	Small, 1-Hole, 3-pk	\$4.12	\$3.71	\$3.50
A18981-1001	Small, 1-Hole, 10-pk	12.15	10.92	10.37
A18981-2001	Large, 2-Hole, 2-pk	4.12	3.71	3.50
A18981-1002	Large, 2-Hole, 8-pk	12.15	10.92	10.37

E Swiss Clips — Four of these spring-loaded, stainless steel clips hold a medium-sized picture up to 30" x 30".

NUMBER	EACH	6/EA	12/EA
A18912-9434	\$5.53	\$4.98	\$4.73

F Framers Pro Wire — A soft, flexible, plastic-coated stainless steel picture-hanging wire for hanging or tying anything.

NUMBER	DESCRIPTION	EACH	6/EA	12/EA
A18982-1030	30 lb, 9 ft	\$4.12	\$3.71	\$3.50
A18982-1050	50 lb, 9 ft	4.12	3.71	3.50

HEALTH & SAFETY ICONS: ●=CL / ■=Prop 65 / ▼=CL & Prop 65
 See page 644 for more information.

Lineco™ Neutral pH Adhesive

White pH-neutral adhesive dries clear and is fast setting, remoistenable with water, and fully reversible. Polyvinyl acetate (PVA) formulation specifically for preservation materials. Should not become brittle with age. Adheres to most porous surfaces.

NUMBER	SIZE	EACH	6/EA
A17314-1004	4 oz	\$5.12	\$4.61
A17314-1005	8 oz	7.63	6.87
A17314-1007	32 oz	25.71	23.14
A17314-1009	Gallon	63.18	56.86



Lineco™ Gummed Linen Hinging Tape

Compatible with paper, board, and most porous surfaces. Pliable and ideal for use as a hinge material or for repair work. Adhesive is reversible with water.

1" Wide Rolls

NUMBER	COLOR	LENGTH	EACH	6/EA
A17310-1030	White	30 ft	\$19.81	\$17.82
A17310-1001	White	50 yd	60.78	54.71
A17310-1011	White	100 yd	111.65	100.50

1-1/2" Wide Rolls

NUMBER	COLOR	LENGTH	EACH	6/EA
A17310-1002	White	100 yd	\$128.46	\$115.60



Lineco™ Self-Adhesive Linen Hinging Tape

Coated with a pH-neutral acrylic adhesive of archival quality, this linen hinging tape has a release liner paper. 400"L x 1-1/4"W roll. White.

NUMBER	EACH	6/EA
A17308-1400	\$21.19	\$19.07



Framer's Tape II™

Stronger and thinner than linen or paper tapes. Archival-grade self-adhesive contains no harmful plasticizers. The moisture-proof, non-porous film backing remains stable. Easily reversed with minimal heat from most surfaces, leaving the article in its original state. 180 ft rolls.

NUMBER	WIDTH	EACH	3/EA
A23028-1000	1"	\$12.95	\$11.66
A23028-1002	2"	24.24	21.82

WARNING! Products marked with a Prop 65 symbol (■ or ▼) can expose you to chemicals, including cadmium, which are known to the State of California to cause cancer and birth defects or other reproductive harm. For more information, visit P65Warnings.ca.gov.



Lineco™ Photo Art Bags

Self-sealing 2 mil clear polypropylene bags are an economical archival storage alternative, sealing out dust and dirt while protecting photos from fingerprints and acidic skin oils.

Packs of 10

NUMBER	SIZE	EACH	6/EA
A17327-1012	8" x 10"	\$11.70	\$9.64
A17327-1011	8-1/2" x 11"	12.79	11.51
A17327-1005	11" x 14"	16.07	14.46
A17327-1016	11" x 17"	21.54	19.38
A17327-1013	13" x 19"	23.56	21.20
A17327-1006	16-3/4" x 21"	26.84	24.15

Packs of 50

NUMBER	SIZE	EACH	3/EA
A17327-1057	5" x 7"	\$13.32	\$11.70
A17327-1810	8" x 10"	18.23	16.60
A17327-1017	11" x 17"	34.83	31.34
A17327-1019	13" x 19"	35.37	31.83
A17327-1620	16" x 20"	34.28	30.85

G Wagner™ Heat Gun

Ideal for shrink-wrapping, heating liquids, and softening surface finishes, this versatile heat gun has two settings: High (1200W) and Low (650W). The nozzle measures 1-1/2"Dia x 2"L. Grounded plug for safety.

NUMBER	EACH
A23105-0000	\$80.71

H Master™ EC-200 Heat Gun

Ideal for heating or drying a wide variety of materials, bending plastics, shrink-wrapping, removing decals, spot-drying, and much more, this lightweight 1200W heat gun has a durable thermoplastic housing and a three-wire grounded cordset for maximum user safety. A three-position slide switch controls the fan speed in Off-Low-High modes, and a variable temperature dial adjusts the temperature between 110°F and 930°F.

NUMBER	EACH
A35102-1004	\$55.99

I Master™ Industrial Heat Gun

Use to bend plastics, heat and dry materials, shrink tubing and packaging, cure adhesives, strip paint, and more. Its high 27 CFM and 3400 FPM airflow heats materials quickly. Use its rocker switch to easily shift between the hot, cool, and off settings. Fixed air intake provides consistent temperature up to 800°.

NUMBER	EACH
A35102-1005	\$197.15

Glassine Interleaving Paper

A pH-neutral, milky white, translucent paper for covering prints in storage and for interleaving books. .001" thick.

NUMBER	WIDTH	EACH	3/EA
A17315-1036	36" x 20 yd Roll	\$50.95	\$45.86



Mountex™ Shrink Film

Standard Grade — 75 gauge archival-quality polyolefin. Film is center folded. 100 ft rolls.

NUMBER	SIZE	EACH	3/EA
A23213-1075	24" Wide	\$112.11	\$100.90
A23213-1175	36" Wide	138.29	124.46

Graphics Grade — Tough, 100 gauge archival-quality polyolefin. Film is center folded. 100 ft rolls.

NUMBER	SIZE	EACH	3/EA
A23213-2400	24" Wide	\$124.81	\$112.33
A23213-3600	36" Wide	169.47	152.52

Economy Grade — Your most economical choice. Not archival; not center folded. 500 ft rolls.

NUMBER	SIZE	EACH	3/EA
A23128-1024	24" Wide	\$303.00	\$272.66
A23128-1036	36" Wide	455.00	409.00

Graphics Grade — Not center folded. 500 ft roll.

NUMBER	SIZE	EACH	3/EA
A23128-2036	36" Wide	\$562.00	\$505.00





Blick® Basic Series Presentation Books

Blick's affordable, functional presentation books are ideal for storing, transporting, and displaying your photographs, drawings, and more. The matte-finish covers are made of durable black polypropylene. Each includes 24 acid-free, top-loading, clear polypropylene sheet protectors with acid-free black paper inserts (90 gsm).

NUMBER	H X W	EACH	6/EA
A15274-1085	11" x 8-1/2", Portrait	\$6.29	\$5.65
A15274-1023	12" x 9", Portrait	6.86	6.17
A15274-1005	14" x 11", Portrait	8.68	7.81
A15274-1011	17" x 11", Portrait	11.32	10.19
A15274-1017	17" x 14", Portrait	14.79	13.31
A15274-1013	19" x 13", Portrait	15.71	14.14
A15274-2085	8-1/2" x 11", Landscape	6.29	5.65
A15274-2005	11" x 14", Landscape	8.68	7.81



Prat® Start Refillable Presentation Books

These affordable polypropylene presentation books feature an exclusive modular spiral-ring mechanism to add or replace sheet protectors and allow each page to lie completely flat for viewing. Each includes 10 archival, super-clear polypropylene sheet protectors. Refill pages are sold separately in packs of 10.

NUMBER	COLOR	H X W	EACH	6/EA
A15213-2003	Black	11" x 8-1/2", Portrait	\$23.36	\$20.98
A15213-2005	Black	14" x 11", Portrait	32.52	29.26
A15213-2007	Black	17" x 11", Portrait	38.21	34.39
A15213-2009	Black	19" x 13", Portrait	45.29	40.75
A15213-2015	Black	11" x 14", Landscape	32.52	29.26
A15213-2017	Black	11" x 17", Landscape	38.25	34.43
A15213-2413	Silver	11" x 8-1/2", Portrait	18.98	17.05
A15213-2419	Silver	19" x 13", Portrait	43.39	39.05

Refill Pages — 10 sheets.

NUMBER	H X W	EACH	6/EA
A15213-1013	11" x 8-1/2", Portrait	\$9.43	\$8.52
A15213-1025	14" x 11", Portrait	14.75	13.28
A15213-1037	17" x 11", Portrait	16.73	15.06
A15213-1049	19" x 13", Portrait	20.48	18.42
A15213-1015	11" x 14", Landscape	14.75	13.28
A15213-1017	11" x 17", Landscape	17.57	15.81



A Itoya® Original Art Profolio™

Just slide your artwork into the crystal-clear "pocket" pages for a highly organized and lasting presentation. Made of durable polypropylene, which protects artwork and documents from environmental damage. Designed to lay completely flat when open. Contains 24 pocket pages with black inserts. Spine pocket allows for easy labeling.

NUMBER	H X W	EACH	12/EA
A15019-2050	10" x 8", Portrait	\$12.49	\$11.25
A15019-0012	11" x 8-1/2", Portrait	13.57	12.21
A15019-2003	12" x 9", Portrait	16.65	14.94
A15019-2005	14" x 11", Portrait	23.98	21.58
A15019-9000	17" x 11", Portrait	27.12	24.41
A15019-0017	17" x 14", Portrait	41.68	37.51
A15019-1013	19" x 13", Portrait	41.59	37.44
A15019-2058	20" x 16", Portrait	52.08	46.87
A15019-2059	22" x 17", Portrait	54.96	49.46
A15019-9024	24" x 18", Portrait	57.71	51.94
A15019-2052	8-1/2" x 11", Landscape	14.62	13.12
A15019-2055	11" x 14", Landscape	24.85	22.36
A15019-2057	11" x 17", Landscape	28.29	25.46

B Itoya® IA-Series Art Profolio™

Profolio IA-Series books feature a durable black cover, clear pocket sheets that accommodate 8-1/2" x 11" pages, pre-inserted mounting papers, a reversible spine insert for customized labeling, and an interior storage pocket.

NUMBER	DESCRIPTION	EACH	6/EA
A15271-2006	6 Pages	\$6.89	\$6.19
A15271-2012	12 Pages	9.40	8.46
A15271-2036	36 Pages	17.73	15.96
A15271-2048	48 Pages	21.91	19.71
A15271-2060	60 Pages	26.07	23.46
A15271-2090	90 Pages	36.44	32.80



Itoya® Art Profolio® Advantage

Designed for the serious artist or photographer, this book features a rigid, lightweight polypropylene cover that is acid-free and archival, and a center-mounted, multi-fold spine that lays flat when open. Included are 24 PolyGlass pocket sheets, with thick, black, acid-free mounting paper inserts.

NUMBER	H X W	EACH	6/EA
A15252-1085	11" x 8-1/2", Portrait	\$21.46	\$19.31
A15252-1023	12" x 9", Portrait	24.60	22.14
A15252-1005	14" x 11", Portrait	34.59	31.13
A15252-1117	17" x 11", Portrait	41.78	37.60
A15252-1017	17" x 14", Portrait	54.40	48.96
A15252-1019	19" x 13", Portrait	56.68	50.99
A15252-2005	11" x 14", Landscape	33.69	30.32



C Itoya® Art Profolio® Multi-Ring Binders

Durable, stiff black polypropylene covers are archival and PVC-free to protect your artwork. All binders include 10 crystal-clear PolyGlass pocket pages for unrivaled clarity, with pH-neutral, acid-free black mounting paper inserts. Pages lay flat in easy-opening rings, making these binders ideal for presentation purposes. For PolyGlass refill pages, visit DickBlick.com.

NUMBER	H X W	EACH	6/EA
A15247-1085	11" x 8-1/2", Portrait	\$33.23	\$29.91
A15247-1023	12" x 9", Portrait	36.47	32.81
A15247-1005	14" x 11", Portrait	46.95	42.25
A15247-1011	17" x 11", Portrait	52.49	47.24
A15247-1017	17" x 14", Portrait	71.77	64.60
A15247-1013	19" x 13", Portrait	64.30	57.87
A15247-1018	24" x 18", Portrait	103.08	92.77
A15247-3085	8-1/2" x 11", Landscape	40.53	36.49
A15247-3005	11" x 14", Landscape	51.94	46.75
A15247-3017	11" x 17", Landscape	64.70	58.22

D Itoya® Art Profolio® Mini Multi-Ring Binders

A sleek and slim profile for your presentations that holds up to 20 of the same high-quality Itoya PolyGlass pages as larger multi-ring binders. Assembly is easy with an acrylic ring mechanism that snaps into place and holds pages securely. For PolyGlass refill pages, visit DickBlick.com.

NUMBER	H X W	EACH	6/EA
A15247-2085	11" x 8-1/2", Portrait	\$32.26	\$29.03
A15247-2014	11" x 14", Landscape	44.56	40.11
A15247-2017	11" x 17", Landscape	55.29	49.76



Itoya® Art Profolio® PolyZip® Envelopes

Great for long-term storage of art and photos. Acid-free, lignin-free, and photo-safe, they feature an easy-to-use zip closure that seals out dust and moisture. An expanding 1-1/4" gusset.

NUMBER	H X W	EACH	12/EA
A15313-1685	8-1/2" x 11"	\$3.05	\$2.74
A15313-1623	9" x 12"	3.37	3.03
A15313-1605	11" x 14"	4.03	3.62
A15313-1611	11" x 17"	4.25	3.82
A15313-1619	13" x 19"	5.23	4.70
A15313-1617	14" x 17"	4.68	4.21
A15313-1608	17" x 22"	10.91	9.80
A15313-1601	20" x 26"	13.09	11.76



Star Products® Student Art Folio

Designed specifically for kids, the Student Art Folio is great for carrying, transporting, and storing art projects, homework assignments, and mementos. It also appeals to adults who still have a little bit of the kid in them, as a safe place to store a child's artwork, stories, diplomas, report cards, and more. Ideal for personalization, it's made from heavy-duty, acid-free, 15 pt fiber and has a hook-and-loop closure.

NUMBER	COLOR	H X W X D	EACH	12/EA
A15808-5019	Blue	9-3/4" x 11-3/4" x 2"	\$5.30	\$4.77
A15808-7019	Green	9-3/4" x 11-3/4" x 2"	5.30	4.77
A15808-3019	Red	9-3/4" x 11-3/4" x 2"	5.30	4.77
A15808-4029	Yellow	9-3/4" x 11-3/4" x 2"	5.30	4.77
A15808-5010	Blue	10" x 15" x 2"	5.53	4.98
A15808-7010	Green	10" x 15" x 2"	5.53	4.98
A15808-3010	Red	10" x 15" x 2"	5.53	4.98
A15808-4020	Yellow	10" x 15" x 2"	5.53	4.98
A15808-5012	Blue	12" x 18" x 2"	6.03	5.43
A15808-7012	Green	12" x 18" x 2"	6.03	5.43
A15808-3012	Red	12" x 18" x 2"	6.03	5.43
A15808-4022	Yellow	12" x 18" x 2"	6.03	5.43
A15808-5014	Blue	14" x 20" x 2"	7.69	6.92
A15808-7014	Green	14" x 20" x 2"	7.69	6.92
A15808-3014	Red	14" x 20" x 2"	7.69	6.92
A15808-4024	Yellow	14" x 20" x 2"	7.69	6.92



E Star Products® Red Wallet Portfolios With Tie-Tape Closure

What's old is new again. All the features and benefits of Red Rope portfolios with the security of tie-tape closures. Durable and economical, they're a perfect choice for students to store paper, pads, pencils, drawing supplies, or artwork.

NUMBER	H X W X D	EACH	12/EA
A15126-2995	9-1/2" x 11-3/4" x 2"	\$2.73	\$2.46
A15126-2910	10" x 15" x 2"	3.10	2.79
A15126-2912	12" x 18" x 2"	4.16	3.74
A15126-2914	14" x 20" x 2"	8.36	7.52
A15126-2917	17" x 22" x 2"	9.62	8.65
A15126-2920	20" x 26" x 2"	11.56	10.39
A15126-2923	23" x 31" x 2"	12.42	11.16
A15126-2924	24" x 36" x 2"	20.16	18.12

F Star Products® Dura Tote Water-Resistant Portfolios

Stain- and water-resistant, the acid-free black coating is designed to protect contents, providing archival, safe storage. Expands to 2" capacity; has Velcro closure and a nylon carrying handle.

NUMBER	H X W X D	EACH	12/EA
A15103-2004	10" x 15" x 2"	\$11.95	\$10.64
A15103-2007	14" x 20" x 2"	11.99	10.80
A15103-2009	17" x 22" x 2"	12.20	10.97
A15103-2001	20" x 26" x 2"	14.27	12.56
A15103-2003	23" x 31" x 2"	15.83	14.25



Star Products® Earth-Friendly Portfolios With Tie-Tape Closure

The same portfolios as above, with a tie-tape closure and no handles.

NUMBER	H X W X D	EACH	25/EA
A15088-1009	9-1/2" x 11-3/4" x 2"	\$4.03	\$3.62
A15088-1010	10" x 15" x 2"	4.52	4.06
A15088-1012	12" x 18" x 2"	4.99	4.52
A15088-1020	20" x 26" x 2"	13.48	12.11
A15088-1023	23" x 31" x 2"	14.39	12.94



G Star Products® Red Wallet Handled Portfolios

For storing, protecting, filing, or transporting flat artwork, these durable, lightweight portfolios are made from tough, long-fiber paper. Handles make transport easy. Non-archival.

NUMBER	H X W X D	EACH	12/EA
A15105-1014	14" x 20" x 2"	\$7.15	\$6.43
A15105-1017	17" x 22" x 2"	8.81	7.93
A15105-1001	20" x 26" x 2"	9.45	8.48
A15105-1004	23" x 31" x 2"	10.30	9.24
A15105-1024	24" x 36" x 2"	16.37	14.69

H Star Products® Red Wallet Portfolios

The same durable portfolios as above, with a hook-and-loop closure and no handles.

NUMBER	H X W X D	EACH	12/EA
A15105-1009	9-1/2" x 11-3/4" x 2"	\$2.51	\$2.26
A15105-1005	10" x 15" x 2"	2.59	2.33
A15105-1006	12" x 18" x 2"	3.16	2.85
A15105-1007	14" x 20" x 2"	6.30	5.67
A15105-2988	17" x 22" x 2"	8.13	7.32
A15105-1011	20" x 26" x 2"	9.96	8.97
A15105-1003	23" x 31" x 2"	10.73	9.65
A15105-1008	24" x 36" x 2"	17.99	16.21



Blick® Economy Portfolio Bulk Pack

Made of sturdy corrugated cardboard with a smooth surface, these durable yet disposable portfolios have a cut-out opening at the top for carrying. They are sealed only on the bottom (the sides are open). Great for quick trips or for storage, they come in a handy pack of six portfolios.

NUMBER	DESCRIPTION	H X W	EACH	6/EA
A15098-1266	6-pack	26" x 31"	\$34.98	\$31.48

HEALTH & SAFETY ICONS: ●=CL / ■=Prop 65 / ▼=CL & Prop 65
See page 644 for more information.

WARNING! Products marked with a Prop 65 symbol (■ or ▼) can expose you to chemicals, including cadmium, which are known to the State of California to cause cancer and birth defects or other reproductive harm. For more information, visit P65Warnings.ca.gov.



A



B

Includes Free Utility Case



D



E

A Blick® Essentials Folding Portfolios

The beauty of these compact portfolios is that they tuck into a backpack or bag, but transform quickly into a full-size portfolio. Made from heavyweight nylon, they're designed to protect and transport artwork and other essentials, then fold quickly into a flat and compact square secured by a hook-and-loop closure. Other convenience features include an ergonomic comfort-grip handle and a full-length zipper. Note: Dimensions reflect size when open.

NUMBER	H X W	EACH	6/EA
A15153-1021	17" x 21"	\$12.43	\$11.18
A15153-1026	20" x 26"	16.26	14.62

B Blick Studio® Softside Portfolios

Transport large artwork, pads, drawing boards, display materials, and more with ease and style. Made of heavyweight nylon with reinforced corners, this zippered portfolio features an ergonomic comfort-grip handle, an adjustable, removable shoulder strap, and a 6" x 13" zippered utility case.

NUMBER	COLOR	H X W	EACH	6/EA
A16992-2020	Black	20" x 26"	\$18.96	\$17.05
A16992-2024	Black	24" x 31"	22.76	20.50
A16992-3002	Red	20" x 26"	18.96	17.05
A16992-3000	Red	24" x 31"	22.76	20.50

C Alvin® Prestige™ Deluxe Mesh Bags

Ideal for drafting kits, drawings, artwork, documents, and much more, Alvin Prestige Deluxe Mesh Bags offer both visibility and protection from the elements. The bags are made of durable, see-through vinyl that is reinforced with mesh webbing. They feature a 3/4" gusset, a zippered top, nylon carrying handles, and an exterior black nylon zippered pocket that's perfect for holding small items.

NUMBER	H X W	EACH	12/EA
A15726-1006	12" x 16"	\$23.44	\$21.36
A15726-1020	20" x 26"	41.40	37.73
A15726-1023	23" x 31"	57.43	52.34

D Itoya® Art Profolio® All-Weather Portfolios

Value-priced with a weather-resistant polypropylene cover that has an ultra-shiny, textured finish. These versatile portfolios protect artwork and documents from studio, office, household, and environmental damage.

NUMBER	H X W	EACH	12/EA
A15139-2020	14-1/2" x 20"	\$16.39	\$14.75
A15139-2029	17" x 22"	19.84	17.86
A15139-2021	20" x 26"	22.94	20.65
A15139-2022	23" x 31"	28.69	25.83
A15139-2023	24-1/2" x 36-1/2"	32.14	28.93

E ArtBin® Tote Folios

Perfect for storage in the studio and transporting sketch pads, clipboards, presentation materials, finished work, and supplies, ArtBin Tote Folios are constructed of durable nylon material. They feature roomy interior compartments with zippers, exterior pockets with secure closures, convenient carrying handles, and detachable shoulder straps. For product details, visit DickBlick.com.

NUMBER	H X W	EACH	6/EA
A15068-2020	23" x 27"	\$41.99	\$37.79
A15068-2025	24" x 36"	52.69	47.42



C



F



G

F Dekko™ Portfolios

Form and function at an affordable price! Lightweight and waterproof, these portfolios expand to approximately 1-1/2" wide. Choose Crystal White or Shadow Black.

NUMBER	COLOR	H X W X D	EACH	6/EA
A15115-2014	Black	14" x 18" x 1-1/2"	\$26.92	\$24.22
A15115-2017	Black	17" x 22" x 1-1/2"	30.85	27.76
A15115-2019	Black	19" x 25" x 1-1/2"	39.26	35.32
A15115-2023	Black	23" x 31" x 1-1/2"	41.44	37.30
A15115-1014	White	14" x 18" x 1-1/2"	26.92	24.22
A15115-1017	White	17" x 22" x 1-1/2"	30.85	27.76
A15115-1019	White	19" x 25" x 1-1/2"	39.26	35.32
A15115-1023	White	23" x 31" x 1-1/2"	41.44	37.30

G Cachet® Deluxe Portfolios

A great substitute for flat files, these deluxe portfolios are perfect for transporting drawings and other dry media. The thick, rigid paperboard keeps paper from bending and creasing, and the interior is acid- and lignin-free. The durable black cover is finished with waterbased ink and embossed with a Kivar coating.

NUMBER	H X W	EACH	6/EA
A15104-2017	14" x 18"	\$23.98	\$21.58
A15104-2008	17" x 22"	31.78	28.61
A15104-2011	20" x 26"	43.74	39.36
A15104-2001	20" x 26" no flaps	31.19	28.08
A15104-2013	23" x 31"	52.12	46.91
A15104-2003	23" x 31" no flaps	39.65	35.68



Prat® Start 1 Portfolios and Presentation Cases

These functional portfolios and presentation cases feature embossed, archival, black polypropylene covers and smooth black insides.

Portfolios — These portfolios feature full inner pockets, elastic holding straps, solid molded plastic drop handles and support footings.

NUMBER	H X W X D	EACH	6/EA
A15040-2048	17" x 22" x 1"	\$35.64	\$32.07
A15040-2051	20" x 26" x 1"	45.20	40.68
A15040-2058	23" x 31" x 1"	60.48	54.42
A15040-2015	24" x 36" x 1"	70.17	63.16
A15040-2036	31" x 42" x 1"	106.47	95.82
A15040-2038	17" x 22" x 3"	42.19	37.97
A15040-2021	20" x 26" x 3"	52.18	46.95
A15040-2022	23" x 31" x 3"	64.12	57.71
A15040-2005	24" x 36" x 3"	94.49	85.04
A15040-2046	31" x 42" x 3"	117.51	105.76

Presentation Cases — These cases feature spine-mounted handles, one inside pocket, and a 1" multi-ring (10-ring) mechanism with a 30-page capacity. Ten archival polypropylene pages are included. The case lies completely flat when open. Use Start archival refill pages.

NUMBER	H X W	EACH	6/EA
A15200-2085	11" x 8-1/2", Portrait	\$48.23	\$43.41
A15200-2055	14" x 11", Portrait	76.15	68.54
A15200-2054	17" x 14", Portrait	88.63	79.77
A15200-2057	22" x 17", Portrait	148.16	133.40
A15200-2058	24" x 18", Portrait	152.81	137.50



Prat® Start NR Archival Refill Pages

Protect your most valuable documents with these super-clear polypropylene top-loading sheet protectors. They're 100% archival with black acid-free mounting inserts. Multi-hole perforations offer a host of storage options.

NUMBER	H X W	EACH	6/EA
A16903-2085	11" x 8-1/2", 10 Pack	\$22.24	\$20.03
A16903-2005	14" x 11", 10 Pack	26.18	23.57
A16903-2017	17" x 11", 10 Pack	35.46	31.91
A16903-2007	17" x 14", 5 Pack	17.70	15.93
A16903-2008	22" x 17", 5 Pack	33.49	30.14
A16903-2009	24" x 18", 5 Pack	36.03	32.43



Blick® Storage Tubes

Constructed of rugged PVC plastic, these tubes are ideal for storage and protection of your valuable artwork, blueprints, charts, and documents. The moisture-proof tubes are sealed at one end and have an easy-to-use, removable cap at the other. An adjustable shoulder strap makes them extremely portable. Inner diameter measures 2-3/4".

NUMBER	COLOR	SIZE	EACH	6/EA
A15602-4862	Blue	25.59"	\$15.43	\$13.89
A15602-1602	Clear	25.59"	15.43	13.89
A15602-7032	Green	25.59"	15.43	13.89
A15602-4512	Orange	25.59"	15.43	13.89
A15602-4863	Blue	37"	17.75	15.98
A15602-1603	Clear	37"	17.75	15.98
A15602-7033	Green	37"	17.75	15.98
A15602-4513	Orange	37"	17.75	15.98



Prat® Start 2 Portfolios and Presentation Cases

Elegant and durable, these portfolios feature a black laminated waterproof cover and deluxe linings. Features include a full-size inside pocket, interior elastic holding straps, a smooth-running nylon zipper, and sturdy riveted handles.

Portfolios — Features include a full-size inside pocket, interior elastic holding straps, and sturdy riveted handles.

NUMBER	H X W X D	EACH	6/EA
A15024-1018	17" x 22" x 1"	\$107.60	\$96.84
A15024-1001	20" x 26" x 1"	125.47	112.92
A15024-1004	23" x 31" x 1"	151.30	136.17
A15024-1015	24" x 36" x 1"	197.59	177.83
A15024-1006	31" x 42" x 1"	298.44	268.60
A15024-1028	17" x 22" x 3"	122.24	109.99
A15024-1011	20" x 26" x 3"	143.77	129.39
A15024-1014	23" x 31" x 3"	174.98	157.49
A15024-1016	31" x 42" x 3"	305.00	274.72

Presentation Cases — Spine-mounted handles allow pages to hang downward to avoid wrinkling. Features include black metal protective corners, an inside pocket, and a 1" black multi-ring mechanism that won't snag pages. The case lies completely flat when open. Includes 10 archival polypropylene pages (25-page capacity). Use Start archival refill pages.

NUMBER	H X W	EACH	6/EA
A15010-1085	11" x 8-1/2", Portrait	\$67.65	\$60.89
A15010-1005	14" x 11", Portrait	92.84	83.56
A15010-1007	17" x 14", Portrait	118.03	106.20
A15010-1008	22" x 17", Portrait	154.98	139.50
A15010-1009	24" x 18", Portrait	197.81	177.99



Alvin® Twist-Lock Telescoping Storage Tubes

These durable black plastic tubes with a 3" (8 cm) inside diameter accommodate materials of varying lengths. To extend, simply twist the tube and friction-lock it at the desired length. The twist-off screw cap is attached to an adjustable, removable shoulder strap. Water-resistant exterior is ideal for protecting drawings, blueprints, charts, maps, posters, and more from the elements.

NUMBER	SIZE	EACH	6/EA
A03221-1000	27-50"	\$35.57	\$31.99



Krystal Seal™ Bags

Slip your mounted or unmounted art into a Krystal Seal Bag, fold over the resealable flap, and you're ready to display or store your art — while protecting it from dust, dirt, and fingerprints. The crystal-clear, acid-free, archival bags are made of 2 mm polypropylene. Packs of 25.

NUMBER	SIZE	EACH	12/EA
A16984-1046	4" x 6"	\$5.29	\$4.76
A16984-1057	5" x 7"	6.16	5.54
A16984-1068	6" x 8"	6.77	6.10
A16984-1810	8" x 10"	7.42	6.71
A16984-8511	8-1/2" x 11"	8.84	7.96
A16984-1912	9" x 12"	10.58	9.52
A16984-1114	11" x 14"	12.29	11.06
A16984-1117	11" x 17"	13.59	12.23
A16984-1216	12" x 16"	13.59	12.23
A16984-1319	13" x 19"	16.71	15.04
A16984-1620	16" x 20"	19.77	17.79
A16984-1824	18" x 24"	27.20	24.48
A16984-2026	20" x 26"	40.81	36.73
A16984-2331	23" x 31"	47.65	42.89



Storex Storage Trays

Great for keeping classrooms and art rooms tidy, Storex Storage trays are sized perfectly for both small and large hands, and feature easy-grip comfort edges. The 10"W x 13"L x 5"H trays are made of non-porous plastic that is dishwasher-safe and drop-resistant. The set of five trays includes one each of Blue, Green, Purple, Red, and Yellow, bright colors that are ideal for STEM or STEAM organizations.

NUMBER	DESCRIPTION	EACH	6/EA
A03376-1001	Trays	\$27.45	\$24.70
A03376-1002	Pack of 5 Lids	12.86	11.57



Storex Classroom Caddies

Storex Classroom Caddies make it easy to just grab and go! Made of lightweight, impact-resistant plastic, each caddy has divided compartments and a rounded handle with no sharp edges, so they're great for young children. Washable and dishwasher-safe, they nest neatly when empty. These sets of five include Blue, Green, Purple, Red, and Yellow.

NUMBER	DESCRIPTION	SIZE	EACH	6/EA
A15906-1001	Small	9-1/4"L x 9-1/4"W x 5-1/4"D	\$30.47	\$27.42
A15906-1002	Large	13"L x 11"W x 6-3/8"D	34.45	30.99



Learning Resources® Create-a-Space™ Storage Center

Create an organized space for little learners to be creative! This circular storage unit is great for keeping art materials all in one place. Perfect for classrooms and playrooms, it has a 12" diameter circular tray that holds eight removable containers with handholds, plus a removable center cup — perfect for storing and accessing a variety of art and classroom supplies. One-year manufacturer's warranty.

NUMBER	EACH	6/EA
A03374-1001	\$28.75	\$25.86

Storex Interlocking Trays

Essential organization tools in bright classroom colors! These handy trays can be used singly, or locked together in custom configurations in drawers or on work surfaces. Ideal for pencils, pens, markers, glue sticks, scissors, and other school or art supplies. Set of five includes Blue, Green, Purple, Red, and Yellow.

NUMBER	DESCRIPTION	SIZE	EACH	6/EA
A15907-1001	Set of 5	9-1/4"L x 3"W x 1.9"D	\$6.85	\$6.17



A



B



D



E



C

Blick® Archival Clamshell Boxes

Archival-quality storage that's extra-durable and acid-free. Strong metal edges at the corners prevent crushing, and the easy-open one-piece clamshell design is ideal for storing photographs, artwork, or documents. White interior.

NUMBER	COLOR	SIZE	EACH	6/EA
A15315-2023	Black	9"L x 12"W x 2"D	\$16.70	\$15.03
A15315-2005	Black	11"L x 14"W x 2"D	19.68	17.72
A15315-2017	Black	11"L x 17"W x 2"D	22.44	20.20
A15315-2019	Black	13"L x 19"W x 2"D	24.21	21.79
A15315-2008	Black	16"L x 20"W x 2"D	31.33	28.20
A15315-2009	Black	18"L x 24"W x 2"D	30.22	27.20
A15315-2002	Black	22"L x 30"W x 2"D	33.68	30.31
A15315-2523	Gray	9"L x 12"W x 2"D	16.70	15.03
A15315-2505	Gray	11"L x 14"W x 2"D	19.68	17.72
A15315-2517	Gray	11"L x 17"W x 2"D	22.44	20.20
A15315-2519	Gray	13"L x 19"W x 2"D	24.21	21.79
A15315-2508	Gray	16"L x 20"W x 2"D	31.33	28.20
A15315-2509	Gray	18"L x 24"W x 2"D	30.22	27.20
A15315-2502	Gray	22"L x 30"W x 2"D	33.68	30.31

A-E Pro Art Plastic Boxes

These portable plastic boxes offer easy access to frequently used items like brushes, pencils, pens, knives, and other art materials, while sturdy latches and hinges keep them secure. Lockable.

Basic Organizer — Simple box, no tray.

NUMBER	COLOR	SIZE	EACH	6/EA
A03263-4861	A Blue	12"L x 6"W x 5"D	\$7.05	\$6.35
A03263-1812	B Clear	12"L x 6"W x 5"D	7.05	6.35

Boxes with Organizer Tray

NUMBER	COLOR	SIZE	EACH	6/EA
A03263-4016	C Blue	16"L x 8"W x 6-1/4"D	\$18.73	\$16.86
A03263-4019	D Blue	19"L x 10-1/4"W x 9"D	19.83	17.85

2-Tray Cantilever Art Box and Adjustable Dividers

NUMBER	COLOR	SIZE	EACH	6/EA
A03263-1014	E Blue	14"L x 8"W x 7"D	\$15.40	\$13.86

ARTBIN®

Manufactured in the USA, ArtBin products are made from the highest-quality plastics available. ArtBin's many years of design and molding expertise are integrated into every storage box, bin, carrying case, tube, and tote — great choices for storing and transporting your essential art and craft supplies.

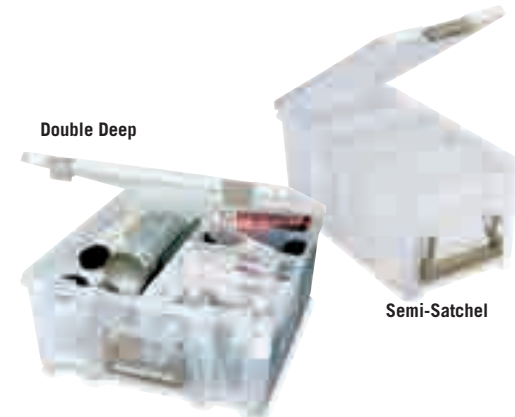

Double Deep

Semi-Satchel

ArtBin® Super Satchel™ Storage Bins

The Semi-Satchel has extra depth and three removable dividers for storing and transporting cardstock, embossing folders, punches, and other supplies. The Double Deep is extra deep for storage of large jars, cans, and supplies. Use it as is, or customize it using the six included translucent dividers. The Super Satchel has six fixed compartments and 12 removable dividers for storage possibilities galore. Use it for art, craft, sewing, and other supplies. It also fits into the ArtBin Super Satchel Cube. All are made of translucent, acid-free polypropylene, and are stackable.

Semi-Satchel

NUMBER	SIZE	EACH	3/EA
A03298-1002	15"L x 8"W x 6-1/4"D	\$19.10	\$17.19

Double Deep

NUMBER	SIZE	EACH	3/EA
A03298-1001	15"L x 14"W x 6-1/4"D	\$35.97	\$32.35

Super Satchel — (not shown)

NUMBER	SIZE	EACH	3/EA
A03298-1003	15-1/4" x 14" x 3-1/2"	\$20.78	\$18.70



2-Tray

3-Tray

ArtBin® Essentials Boxes

ArtBin Essentials Boxes have been redesigned to offer even more flexibility and storage. Made of sturdy, durable plastic, these boxes feature ArtBin's tongue-and-groove construction, with sturdy handles and secure latches. Choose boxes with one, two, or three trays.

NUMBER	DESCRIPTION	SIZE	EACH	4/EA
A15904-2021	1-Tray Box	13"L x 7-7/8"W x 6-1/2"D	\$20.33	\$18.30

A15904-2022	2-Tray Box	14"L x 8"W x 7"D	24.73	22.26
A15904-2023	3-Tray Box	15-3/4"L x 9"W x 8-3/8"D	32.98	29.68

A03243-8300	3-Tray XL	20"L x 10-1/2"W x 10-1/4"D	41.93	37.74
-------------	-----------	----------------------------	-------	-------

Cube with Paint Palette



X-Large Black

ArtBin® Sidekick™ Storage Bins

These tough polypropylene totes feature secure latches and side-opening lids. There's additional storage in the top of the lid, and a lift-out tray reveals a generous bulk storage area. Handy carrying handle.

NUMBER	DESCRIPTION	SIZE	EACH	4/EA
A03269-1011	Mini, Clear	11"L x 5-1/2"W x 7"D	\$14.55	\$13.09

A03269-1010	Medium, Clear	15"L x 7-3/4"W x 10"D	26.18	23.57
-------------	---------------	-----------------------	-------	-------

A03269-2050	X-Large, Black	18"L x 9-3/4"W x 12-1/2"D	42.98	38.69
-------------	----------------	---------------------------	-------	-------

A03269-1020	Cube w/ Paint Palette	11-13/16" x 7-7/8" x 5-9/16"	17.89	16.09
-------------	-----------------------	------------------------------	-------	-------

ArtBin® Quick-View Carrying Cases

Quick-View Carrying Cases are molded in translucent polypropylene with a "window" for a quick view of what's inside. Secure lockable latches keep the contents secure, and easy-grip, molded handles make these cases easy to just grab and go!

NUMBER	SIZE	EACH	6/EA
A03238-1040	8-3/8"L x 10-1/2"W x 3-1/8"D	\$10.45	\$9.40

A03238-1012	9-7/8"L x 12"W x 3-1/4"D	11.79	10.60
-------------	--------------------------	-------	-------

A03274-1020	10-1/4"L x 14"W x 3-3/8"D	12.55	11.29
-------------	---------------------------	-------	-------

A03238-1015	15"L x 14-3/8"W x 3-1/4"D	18.55	16.66
-------------	---------------------------	-------	-------

NUMBER	SIZE	EACH	6/EA
A03238-2015	15"L x 14-3/8"W x 3-1/4"D	\$31.38	\$28.24



ArtBin® Pencil Box

Perfect for organizing pencils, pens, cutting tools, and other supplies, the ArtBin Pencil Box is molded from sturdy tinted translucent polypropylene. Foam inserts protect pencil points and other sharp tips.

NUMBER	COLOR	SIZE	EACH	6/EA
A03336-2610	Translucent	12-3/8"L x 4-7/8"W x 1-3/4"D	\$7.38	\$6.64



Blick® Storage Box

An economical way to transport, store, and organize art supplies, the Blick Storage Box is made of tough, translucent polypropylene with a side-opening lid and secure latch. A lift-out tray reveals a generous bulk storage area, and there's additional storage in the top of the lid. Includes a comfortable carrying handle.

NUMBER	SIZE	EACH	4/EA
A03296-1001	15"L x 10"W x 7-3/4"D	\$20.94	\$18.85



Blick® Mesh Zipper Bags

These see-through zippered mesh bags are great for organizing and protecting school and art supplies. Made from PVC, they're available in a variety of sizes.

NUMBER	SIZE	EACH	12/EA
A16974-2010	5" x 10"	\$3.30	\$2.97

A16974-2007	9-1/2" x 7-1/2"	4.07	3.66
-------------	-----------------	------	------

A16974-2013	10" x 13"	5.17	4.65
-------------	-----------	------	------

A16974-2016	12" x 16"	6.71	6.05
-------------	-----------	------	------

A16974-2026	20" x 26"	10.65	9.59
-------------	-----------	-------	------

A16974-2032	24" x 32"	14.21	12.79
-------------	-----------	-------	-------

BLICK® studio art markers



Blick's double-ended Studio Art Markers were created to offer professionals and students a high-quality alternative to higher-priced markers. Appropriate for all areas of design and illustration, they feature a fine nib that is ideal for sketching and detail work, and a broad nib that lays down an abundance of rich color in three different line widths. Choose from 95 water-resistant, fade-resistant colors (plus a colorless blender). A non-roll cap design prevents markers from rolling off work surfaces. **Colors can be assorted for quantity pricing.**



NUMBER	COLOR	EACH	6/EA
A22148-1120	Antique	\$3.83	\$3.45
A22148-1200	Antique White		
A22148-7170	Apple Green		
A22148-2110	Basic Gray 1		
A22148-2120	Basic Gray 2		
A22148-2130	Basic Gray 3		
A22148-2140	Basic Gray 4		
A22148-2150	Basic Gray 5		
A22148-2160	Basic Gray 6		
A22148-8090	Beach		
A22148-2020	Black		
A22148-3710	Brick Red		
A22148-5480	Bright blue		
A22148-7250	Bright Green		
A22148-4700	Burnt Orange		
A22148-4070	Butter Cream		
A22148-8710	Camel		
A22148-4260	Canary Yellow		
A22148-8340	Caramel		
A22148-7480	Celadon Green		
A22148-5160	Cerulean Blue		
A22148-7630	Chartreuse		
A22148-0000	Colorless Blender		
A22148-2410	Cool Gray 10%		
A22148-2420	Cool Gray 20%		
A22148-2430	Cool Gray 30%		
A22148-2440	Cool Gray 40%		
A22148-2450	Cool Gray 50%		
A22148-2460	Cool Gray 60%		
A22148-2470	Cool Gray 70%		

NUMBER	COLOR	EACH	6/EA
A22148-2480	Cool Gray 80%		
A22148-2490	Cool Gray 90%		
A22148-3240	Coral Pink		
A22148-8030	Dark Brown		
A22148-7030	Dark Green		
A22148-7040	Dark Olive Green		
A22148-8380	Dark Umber		
A22148-2590	Gray Lavender		
A22148-7910	Green Tomato		
A22148-4120	Honey Yellow		
A22148-5450	Horizon Blue		
A22148-5110	Ink Blue		
A22148-8110	Latte		
A22148-7150	Leaf Green		
A22148-5820	Light Cerulean Blue		
A22148-4110	Light Maize		
A22148-3680	Light Peach		
A22148-5760	Light Periwinkle		
A22148-8430	Light Umber		
A22148-6030	Lilac		
A22148-7230	Lime		
A22148-3040	Magenta		
A22148-5040	Navy Blue		
A22148-7070	Olive		
A22148-4510	Orange		
A22148-3350	Peach		
A22148-3730	Peach Blush		
A22148-5770	Periwinkle		
A22148-3060	Pink		
A22148-3610	Poppy Red		
A22148-6000	Purple		
A22148-1620	Putty		
A22148-3010	Red		
A22148-3170	Rose Petal		
A22148-4960	Saffron		
A22148-7400	Sage		
A22148-3510	Salmon Pink		
A22148-8540	Sand		
A22148-8080	Sepia		
A22148-3780	Shell		
A22148-8120	Sienna		
A22148-3790	Spice		



NUMBER	COLOR	EACH	6/EA
A22148-7330	Spring Green		
A22148-5380	Steel Blue		
A22148-1130	Stone		
A22148-8230	Tan		
A22148-8300	Taupe		
A22148-7080	Teal Green		
A22148-3760	Terra Cotta		
A22148-5080	True Blue		
A22148-5230	Ultramarine		
A22148-3700	Very Berry		
A22148-6510	Violet		
A22148-8910	Walnut		
A22148-2280	Warm Black		
A22148-2710	Warm Gray 10%		
A22148-2720	Warm Gray 20%		
A22148-2730	Warm Gray 30%		
A22148-2740	Warm Gray 40%		
A22148-2750	Warm Gray 50%		
A22148-2760	Warm Gray 60%		
A22148-2770	Warm Gray 70%		
A22148-2780	Warm Gray 80%		
A22148-2790	Warm Gray 90%		
A22148-3720	Wine		
A22148-4040	Yellow Ochre		

EACH \$3.83 6/EA \$3.45



Blick® Studio Marker Sets

Sets of specially selected colors in boxes with plastic trays for easy organization. (Six-color set has no tray.) For color listings, visit DickBlick.com.

NUMBER	SET	EACH	3/EA
A22148-1006	6 Colors	\$20.05	\$18.05
A22148-2809	12 Cool Grays	39.99	35.99
A22148-2329	12 Warm Grays	39.99	35.99
A22148-1012	12 Colors	39.99	35.99
A22148-1024	24 Colors	75.99	67.99
A22148-1048	48 Colors	152.10	136.99
A22148-1096	96 Colors	305.00	274.50

BLICK® studio brush markers



Blick is pleased to introduce an exclusive line of high-quality yet affordable brush markers for artists in all areas of graphic design and illustration. Available in the same range of water-resistant, fade-resistant colors as Blick Studio Markers, Blick Studio Brush Markers feature a brush tip on one end, a durable chisel tip on the other, and an ergonomic flat barrel that is comfortable to use and won't roll off work surfaces. Choose from 95 brilliant colors plus a colorless blender. For set colors, visit DickBlick.com. **Colors can be assorted for quantity pricing.**

NUMBER	COLOR	EACH	6/EA
A24532-1005	Antique		
A24532-1200	Antique White		
A24532-7170	Apple Green		
A24532-2810	Basic Gray 1		
A24532-2820	Basic Gray 2		
A24532-2830	Basic Gray 3		
A24532-2840	Basic Gray 4		
A24532-2850	Basic Gray 5		
A24532-1012	Basic Gray 6		
A24532-1002	Beach		
A24532-2020	Black		
A24532-3140	Brick Red		
A24532-5140	Bright Blue		
A24532-7250	Bright Green		
A24532-4700	Burnt Orange		
A24532-4070	Butter Cream		
A24532-8710	Camel		
A24532-4260	Canary Yellow		
A24532-8340	Caramel		
A24532-7480	Celadon Green		
A24532-5160	Cerulean Blue		
A24532-3710	Chartreuse		
A24532-1001	Colorless Blender		
A24532-2450	Cool Gray 10%		
A24532-2460	Cool Gray 20%		
A24532-2470	Cool Gray 30%		
A24532-2110	Cool Gray 40%		
A24532-3560	Cool Gray 50%		
A24532-2111	Cool Gray 60%		
A24532-2490	Cool Gray 70%		
A24532-2112	Cool Gray 80%		
A24532-2500	Cool Gray 90%		
A24532-3240	Coral Pink		

EACH \$3.83 6/EA \$3.45

NUMBER	COLOR	EACH	6/EA
A24532-8030	Dark Brown		
A24532-7030	Dark Green		
A24532-7070	Dark Olive Green		
A24532-8380	Dark Umber		
A24532-6150	Gray Lavender		
A24532-1006	Green Tomato		
A24532-1003	Honey Yellow		
A24532-5450	Horizon Blue		
A24532-1007	Ink Blue		
A24532-1008	Latte		
A24532-7150	Leaf Green		
A24532-5820	Light Cerulean Blue		
A24532-4370	Light Maize		
A24532-3680	Light Peach		
A24532-6160	Light Periwinkle		
A24532-8430	Light Umber		
A24532-6030	Lilac		
A24532-7230	Lime		
A24532-3040	Magenta		
A24532-5040	Navy Blue		
A24532-7071	Olive		
A24532-4510	Orange		
A24532-3350	Peach		
A24532-3700	Peach Blush		
A24532-6170	Periwinkle		
A24532-3060	Pink		
A24532-3610	Poppy Red		
A24532-6000	Purple		
A24532-8490	Putty		
A24532-3010	Red		
A24532-3170	Rose Petal		
A24532-4960	Saffron		
A24532-7400	Sage		

EACH \$3.83 6/EA \$3.45

NUMBER	COLOR
A24532-3510	Salmon Pink
A24532-8540	Sand
A24532-8080	Sepia
A24532-1009	Shell
A24532-8120	Sienna
A24532-1010	Spice
A24532-7330	Spring Green
A24532-5380	Steel Blue
A24532-2670	Stone
A24532-8230	Tan
A24532-8300	Taupe
A24532-1011	Teal Green
A24532-4910	Terra Cotta
A24532-5280	True Blue
A24532-5230	Ultramarine
A24532-1004	Very Berry
A24532-6510	Violet
A24532-8910	Walnut
A24532-2280	Warm Black
A24532-2710	Warm Gray 10%
A24532-2720	Warm Gray 20%
A24532-2730	Warm Gray 30%
A24532-2740	Warm Gray 40%
A24532-2750	Warm Gray 50%
A24532-2760	Warm Gray 60%
A24532-2770	Warm Gray 70%
A24532-2780	Warm Gray 80%
A24532-2790	Warm Gray 90%
A24532-3720	Wine
A24532-4040	Yellow Ochre

EACH \$3.83 6/EA \$3.45



NUMBER	SETS	EACH	3/EA
A24532-1069	6 Colors	\$20.05	\$18.05
A24532-1019	6 Blues	20.05	18.05
A24532-1029	6 Florals	20.05	18.05
A24532-1049	6 Grays	20.05	18.05
A24532-1059	6 Greens	20.05	18.05
A24532-1129	12 Colors	39.99	35.99
A24532-1229	12 Portrait	39.99	35.99
A24532-1249	24 Colors	75.99	67.99
A24532-1489	48 Colors	152.10	136.99
A24532-1969	96 Colors	305.00	274.50
A24532-1449	144 Colors	383.00	343.00

Blick® Studio Marker Ink Refills

Bring your Blick Studio Art Markers and Brush Markers back to life! The water-resistant, fade-resistant ink is the same as that used in the manufacture of Blick Studio Markers and Blick Studio Brush Markers, ensuring the same beautiful colors and the same results. Each bottle contains 0.85 oz (25 ml) of alcohol-based, permanent ink, enough to refill a marker 7-9 times. The cap colors match the marker caps for easy reference. **Colors can be assorted for quantity pricing.**

NUMBER	COLOR	EACH	6/EA
A00862-1010	Antique		
A00862-1200	Antique White		
A00862-7170	Apple Green		
A00862-2810	Basic Gray 1		
A00862-2820	Basic Gray 2		
A00862-2830	Basic Gray 3		
A00862-2840	Basic Gray 4		
A00862-2850	Basic Gray 5		
A00862-2860	Basic Gray 6		
A00862-1020	Beach		
A00862-2020	Black		
A00862-3140	Brick Red		
A00862-5140	Bright Blue		
A00862-7250	Bright Green		
A00862-4700	Burnt Orange		
A00862-4070	Butter Cream		
A00862-8710	Camel		
A00862-4260	Canary Yellow		
A00862-8340	Caramel		
A00862-7480	Celadon Green		
A00862-5160	Cerulean Blue		
A00862-3710	Chartreuse		
A00862-1030	Colorless Blender		
A00862-2451	Cool Gray 10		
A00862-2462	Cool Gray 20		
A00862-2473	Cool Gray 30		
A00862-2114	Cool Gray 40		
A00862-3565	Cool Gray 50		
A00862-2116	Cool Gray 60		
A00862-2497	Cool Gray 70		
A00862-2118	Cool Gray 80		
A00862-2509	Cool Gray 90		
A00862-3240	Coral Pink		
A00862-8030	Dark Brown		
A00862-7030	Dark Green		
A00862-7071	Dark Umber		
A00862-6150	Gray Lavender		
A00862-1040	Green Tomato		

EACH \$5.92 6/EA \$5.32

NUMBER	COLOR	EACH	6/EA
A00862-1050	Honey Yellow		
A00862-5450	Horizon Blue		
A00862-1060	Ink Blue		
A00862-1070	Latte		
A00862-7150	Leaf Green		
A00862-5820	Light Cerulean Blue		
A00862-4370	Light Maize		
A00862-3680	Light Peach		
A00862-6160	Light Periwinkle		
A00862-8430	Light Umber		
A00862-1100	Lilac		
A00862-7230	Lime		
A00862-3040	Magenta		
A00862-5040	Navy		
A00862-7070	Olive		
A00862-4510	Orange		
A00862-3350	Peach		
A00862-3700	Peach Blush		
A00862-6170	Periwinkle		
A00862-3060	Pink		
A00862-3610	Poppy Red		
A00862-3170	Rose Petal		
A00862-7400	Sage		
A00862-3510	Salmon Pink		
A00862-8540	Sand		

EACH \$5.92 6/EA \$5.32

NUMBER	COLOR	EACH	6/EA
A00862-8080	Sepia		
A00862-1080	Shell		
A00862-8120	Sienna		
A00862-1090	Spice		
A00862-7330	Spring Green		
A00862-5380	Steel Blue		
A00862-2670	Stone		

PRISMACOLOR



PrismaColor Premier Markers

Create four line widths from one double-ended marker. Each marker has "click-fit" cap to prevent marker dry-out and nib damage and each cap has an accurate color I.D. dot for easy identification. One end has an extra-broad nib that lays down color fast with paintbrush-like strokes and the other end has a fine nib for sketching, detail work, or cleanup. Solvent-based ink is fade-resistant and water-resistant. Colors can be assorted for quantity pricing.

Individual PrismaColor Markers

NUMBER	COLOR
A21342-0000	Colorless Blender
A21342-7171	Apple Green (167)
A21342-5361	Aquamarine (37)
A21342-2631	Ash Grey (206)
A21342-7460	Avocado (192)
A21342-3061	Ballet Pink (208)
A21342-2001	Black (98)
A21342-4913	Blondwood (96)
A21342-5311	Blue Slate (145)
A21342-3712	Blush Pink (10)
A21342-8612	Brick Beige (78)
A21342-1381	Brick White (79)
A21342-5913	Brittany Blue (142)
A21342-4914	Bronze (149)
A21342-8910	Buff (71)
A21342-8271	Burnt Ochre (93)
A21342-4261	Canary Yellow (19)
A21342-3151	Carmine Red (6)
A21342-7481	Celadon Green (140)
A21342-5161	Cerulean Blue (126)
A21342-7631	Chartreuse (27)
A21342-8774	Cherry (86)
A21342-8350	Cinnamon Toast (201)
A21342-3653	Clay Rose (137)
A21342-5915	Cloud Blue (144)
A21342-8361	Cocoa Bean (214)
A21342-7960	Cold Stone (194)
A21342-2108	Cool Grey 10% (108)
A21342-2109	Cool Grey 20% (109)
A21342-2111	Cool Grey 40% (111)
A21342-2112	Cool Grey 50% (112)
A21342-2113	Cool Grey 60% (113)
A21342-2114	Cool Grey 70% (114)
A21342-2115	Cool Grey 80% (115)
A21342-2116	Cool Grey 90% (116)
A21342-5914	Copenhagen Blue (40)
A21342-1101	Cream (23)
A21342-3161	Crimson Red (4)

EACH \$5.10 6/EA \$4.59

Individual PrismaColor Markers

NUMBER	COLOR
A21342-8031	Dark Brown (88)
A21342-7031	Dark Green (31)
A21342-6011	Dark Purple (168)
A21342-8382	Dark Umber (61)
A21342-5881	Deco Blue (134)
A21342-4731	Deco Orange (130)
A21342-3675	Deco Peach (11)
A21342-3666	Deco Pink (133)
A21342-4681	Deco Yellow (131)
A21342-2601	Driftwood (203)
A21342-6001	Eggplant (213)
A21342-4915	Eggshell (72)
A21342-7052	Emerald (186)
A21342-3757	Flagstone Red (73)
A21342-7270	Forest Green (184)
A21342-2611	French Grey 10% (155)
A21342-2612	French Grey 20% (156)
A21342-2613	French Grey 30% (157)
A21342-2614	French Grey 40% (158)
A21342-2615	French Grey 50% (159)
A21342-2616	French Grey 60% (160)
A21342-2617	French Grey 70% (161)
A21342-2618	French Grey 80% (162)
A21342-2619	French Grey 90% (163)
A21342-4691	Goldenrod (69)
A21342-7241	Grass Green (165)
A21342-6151	Greyed Lavender (147)
A21342-7760	Green Tea (197)
A21342-3738	Henna (152)
A21342-6911	Imperial Violet (127)
A21342-5201	Indigo Blue (43)
A21342-7221	Jade Green (141)
A21342-4732	Jasmine (132)
A21342-2041	Jet Black (211)
A21342-8261	Khaki (209)
A21342-7151	Leaf Green (187)
A21342-5832	Light Aqua (46)
A21342-5531	Light Blue (47)
A21342-5821	Light Cerulean Blue (48)

EACH \$5.10 6/EA \$4.59

Individual PrismaColor Markers

NUMBER	COLOR
A21342-3689	Light Peach (12)
A21342-8421	Light Tan (95)
A21342-8433	Light Umber (172)
A21342-8916	Light Walnut (89)
A21342-6031	Lilac (171)
A21342-7231	Lime Green (36)
A21342-7912	Limepeel (124)
A21342-7910	Lt. Olive Green (26)
A21342-3041	Magenta (7)
A21342-3811	Mahogany Red (150)
A21342-5911	Mediterranean Blue (143)
A21342-4751	Mineral Orange (154)
A21342-7540	Mint Cream (193)
A21342-8310	Mocha Dark (200)
A21342-8300	Mocha Light (199)
A21342-6611	Mulberry (53)
A21342-7950	Muted Turquoise (198)
A21342-5046	Navy Blue (45)
A21342-8001	Oatmeal (210)
A21342-7074	Dark Olive Green (28)
A21342-4501	Orange (16)
A21342-7210	Pale Jade (191)
A21342-3341	Pale Peach (207)
A21342-3763	Pale Vermilion (14)
A21342-7381	Parchment (205)
A21342-6913	Parma Violet (128)
A21342-7241	Parrot Green (32)
A21342-3351	Peach (170)
A21342-5211	Peacock Blue (125)
A21342-5771	Periwinkle (146)
A21342-2581	Pewter (212)
A21342-3051	Pink (8)
A21342-3611	Poppy Red (13)
A21342-3774	Process Red (1)
A21342-4621	Pumpkin Orange (153)
A21342-1621	Putty (80)
A21342-3361	Raspberry (151)
A21342-3715	Rhodamine (55)
A21342-3511	Salmon Pink (122)

EACH \$5.10 6/EA \$4.59

Individual PrismaColor Markers

NUMBER	COLOR
A21342-4916	Sand (70)
A21342-3411	Scarlet Lake (5)
A21342-8081	Sepia (62)
A21342-8125	Sienna Brown (65)
A21342-5070	Sky Blue Light (202)
A21342-4801	Spanish Orange (123)
A21342-7790	Spearmint (195)
A21342-4541	Sunburst Yellow (17)
A21342-2621	Taupe (204)
A21342-5087	Teal Blue (38)
A21342-3151	Terra Cotta (82)
A21342-4912	Terra Cotta (82)
A21342-8911	True Blue (39)
A21342-7421	True Green (166)
A21342-4917	Tulip Yellow (21)
A21342-3727	Tuscan Red (169)
A21342-5231	Ultramarine (44)
A21342-6501	Violet (50)
A21342-5391	Violet Blue (42)
A21342-6912	Violet Mist (60)
A21342-8911	Walnut (90)
A21342-2280	Warm Black (97)
A21342-2699	Warm Grey 10% (99)
A21342-2100	Warm Grey 20% (100)
A21342-2101	Warm Grey 30% (101)
A21342-2102	Warm Grey 40% (102)
A21342-2103	Warm Grey 50% (103)
A21342-2104	Warm Grey 60% (104)
A21342-2105	Warm Grey 70% (105)
A21342-2106	Warm Grey 80% (106)
A21342-2107	Warm Grey 90% (107)
A21342-8920	Wheat (196)
A21342-4041	Yellow Ochre (18)
A21342-4841	Yellowed Orange (15)

EACH \$5.10 6/EA \$4.59

Single-Nib Metallics

NUMBER	COLOR	EACH	6/EA
A21342-9421	Silver-Fine (118)	\$5.42	\$4.85
A21342-9321	Silver-Broad (117)	5.42	4.85



PrismaColor Premier Carry Cases with Markers

Offered in sets of 24 or 48, these markers are packaged in a durable marker case.

NUMBER	DESCRIPTION	EACH	3/EA
A21342-1009	Case with 24 Markers	\$117.95	\$106.20
A21342-0489	Case with 48 Markers	235.50	211.99
A22726-1024	Empty Case Holds 24	24.24	21.82

HEALTH & SAFETY ICONS: ●=CL / ■=Prop 65 / ▼=CL & Prop 65
See page 644 for more information.

PRISMACOLOR



Individual PrismaColor Markers

NUMBER	COLOR
A19901-7171	Apple Green (167)
A19901-5171	Aquamarine (37)
A19901-2611	Ash Grey (206)
A19901-7461	Avocado (192)
A19901-3091	Ballet Pink (208)
A19901-2021	Black (98)
A19901-4921	Blondwood (96)
A19901-5311	Blue Slate (145)
A19901-3711	Blush Pink (10)
A19901-8611	Brick Beige (78)
A19901-1381	Brick White (79)
A19901-5921	Brittany Blue (142)
A19901-8151	Bronze (149)
A19901-8621	Buff (71)
A19901-8271	Burnt Ochre (93)
A19901-4261	Canary Yellow (19)
A19901-3151	Carmine Red (6)
A19901-7481	Celadon Green (140)
A19901-5161	Cerulean Blue (126)
A19901-7631	Chartreuse (27)
A19901-8451	Cherry (86)
A19901-8351	Cinnamon Toast (201)
A19901-3651	Clay Rose (137)
A19901-5901	Cloud Blue (144)
A19901-8361	Cocoa Bean (214)
A19901-5991	Cold Stone (194)
A19901-1001	Colorless Blender (121)
A19901-2101	Cool Grey 10% (108)
A19901-2201	Cool Grey 20% (109)
A19901-2301	Cool Grey 30% (110)
A19901-2401	Cool Grey 40% (111)
A19901-2501	Cool Grey 50% (112)
A19901-2601	Cool Grey 60% (113)
A19901-2701	Cool Grey 70% (114)
A19901-2801	Cool Grey 80% (115)
A19901-2901	Cool Grey 90% (116)
A19901-5911	Copenhagen Blue (40)
A19901-1101	Cream (23)
A19901-3161	Crimson Red (4)
A19901-8031	Dark Brown (88)
A19901-7031	Dark Green (31)
A19901-7071	Dark Olive Grn (28)
A19901-6011	Dark Purple (168)
A19901-8381	Dark Umber (61)
A19901-5881	Deco Blue (134)
A19901-4741	Deco Orange (130)
A19901-3671	Deco Peach (11)
A19901-3661	Deco Pink (133)
A19901-4731	Deco Yellow (131)
A19901-2621	Driftwood (203)
A19901-6901	Eggplant (213)
A19901-1251	Eggshell (72)
A19901-7051	Emerald (186)
A19901-3751	Flagstone Red (73)
A19901-7271	Forest Green (184)
A19901-2911	French Grey 10% (155)
A19901-2921	French Grey 20% (156)
A19901-2931	French Grey 30% (157)
A19901-2941	French Grey 40% (158)
A19901-2951	French Grey 50% (159)

EACH \$5.10 6/EA \$4.59

Individual PrismaColor Markers

NUMBER	COLOR
A19901-2961	French Grey 60% (160)
A19901-2971	French Grey 70% (161)
A19901-2981	French Grey 80% (162)
A19901-2991	French Grey 90% (163)
A19901-4691	Goldenrod (69)
A19901-7241	Grass Green (165)
A19901-6151	Greyed Lavender (147)
A19901-7431	Green Tea (197)
A19901-8921	Henna (152)
A19901-6931	Imperial Violet (127)
A19901-5201	Indigo Blue (43)
A19901-7221	Jade Green (141)
A19901-4791	Jasmine (132)
A19901-2041	Jet Black (211)
A19901-8261	Khaki (209)
A19901-7151	Leaf Green (187)
A19901-5831	Light Aqua (46)
A19901-5021	Light Blue (47)
A19901-3681	Light Peach (12)
A19901-8421	Light Tan (95)
A19901-8431	Light Umber (172)
A19901-6031	Lilac (171)
A19901-7231	Lime Green (36)
A19901-7921	Limepeel (124)
A19901-5821	Lt Cerulean Blue (48)
A19901-7961	Lt Olive Green (26)
A19901-3041	Magenta (7)
A19901-3771	Mahogany Red (150)
A19901-5811	Mediterranean Bl (143)
A19901-4751	Mineral Orange (154)
A19901-7511	Mint Cream (193)
A19901-8391	Mocha Dark (200)
A19901-8371	Mocha Light (199)
A19901-3591	Mulberry (53)
A19901-5131	Muted Turquoise (198)
A19901-5041	Navy Blue (45)
A19901-1191	Oatmeal (210)
A19901-4591	Orange (16)
A19901-7201	Pale Jade (191)
A19901-3341	Pale Peach (207)
A19901-3761	Pale Vermilion (14)
A19901-1391	Parchment (205)
A19901-6921	Parma Violet (128)
A19901-7781	Parrot Green (32)
A19901-3351	Peach (170)
A19901-5211	Peacock Blue (125)
A19901-5771	Periwinkle (146)
A19901-2581	Pewter (212)
A19901-3061	Pink (8)
A19901-3611	Poppy Red (13)
A19901-3781	Process Red (1)
A19901-4621	Pumpkin Orange (153)
A19901-1621	Putty (80)
A19901-3361	Raspberry (151)
A19901-3731	Rhodamine (55)
A19901-3511	Salmon Pink (122)
A19901-8541	Sand (70)
A19901-3411	Scarlet Lake (5)
A19901-8081	Sepia (62)
A19901-8121	Sienna Brown (65)

EACH \$5.10 6/EA \$4.59

Chartpak Ad™ Marker Sets

These waterproof, permanent, solvent-based markers deliver brilliant, sparkling color in fine point, medium weight, or broad strokes — all from a single nib. For set contents, visit DickBlick.com.

NUMBER	SET	EACH	6/EA
A21303-1019	12 Colors	\$49.97	\$44.97
A21303-1012	12 Portrait	49.97	44.97
A21303-2539	25 Architectural	93.90	84.52
A21303-2549	25 Art Director	93.90	84.52
A21303-2509	25 Basic	93.90	84.52
A21303-3859	25 Fleshtone	93.90	84.52
A21303-2559	25 Landscape	93.90	84.52
A21303-2529	25 Pastel	93.90	84.52
A21303-2519	25 Warm/Cool Gray	93.90	84.52
A21303-1009	100 Colors	378.00	340.00

NUMBER	EACH	6/EA
A21303-0000	\$4.54	\$4.09

WARNING! Products marked with a Prop 65 symbol (■ or ▼) can expose you to chemicals, including cadmium, which are known to the State of California to cause cancer and birth defects or other reproductive harm. For more information, visit P65Warnings.ca.gov.

PrismaColor Premier Double-Ended Brush Tip Markers

With a small tip for details and a large brush tip for larger areas, these markers let you change it up whenever the mood strikes! Featuring the same non-toxic, dye-based alcohol ink as PrismaColor Premier Markers, a shared ink source assures consistency of color from both ends. Colors can be assorted for quantity pricing.

NUMBER	SET	EACH	3/EA
A19901-1129	12 Colors	\$54.10	\$48.75
A19901-2249	24 Color Zip Case	117.95	106.20
A19901-2489	48 Color w/Zip Case	235.50	211.99
A19901-1729	72 Colors	313.00	279.99
A19901-1569	156 Colors	617.00	555.00

Individual PrismaColor Markers

NUMBER	COLOR
A19901-5061	Sky Blue Light (202)
A19901-4801	Spanish Orange (123)
A19901-7191	Spearmint (195)
A19901-7331	Spring Green (25)
A19901	



COPIC

The choice of professionals worldwide, the Copic marker offers outstanding performance in all areas of design and illustration. Two versatile tips produce a range of strokes from fine lines to wide color-fills. The roll-proof, flat barrel is filled with alcohol-based ink for a long life. Choose the Original Copic marker with a broad and fine nib, or the Copic Sketch marker with a brush and broad nib. Fast-drying, permanent, non-toxic, and toner-compatible.



12-Color Set

Set A
Set of 72 Colors

Set of 6 Bold
Primary Colors

Copic Sketch Marker Sets

Copic Sketch Markers are perfect for cartoon illustration, fashion design, and more. Featuring a brush nib and a broad nib, they're filled with fast-drying, alcohol-based ink that is permanent, non-toxic, and toner-compatible. Roll-proof flat barrel.

NUMBER	SET	EACH
A21395-2909	6 Blending Basic Colors	\$52.85
A21395-2409	6 Bold Primary Colors	52.85
A21395-2809	6 Earth Colors	52.85
A21395-2719	6 Floral Colors, Set 1	52.85
A21395-2729	6 Floral Colors, Set 2	52.85
A21395-2709	6 Pale Pastel Colors	52.85
A21395-2609	6 Primary Colors	52.85
A21395-2209	6 Sea & Sky Colors	52.85
A21395-2309	6 Secondary Colors	52.85
A21395-2509	6 Sketching Grays	52.85
A21395-2109	6 Skin Tones Colors, Set 1	52.85
A21395-0129	12 Basic Colors	90.75
A21395-1249	24 Basic Colors	187.94
A21395-0369	36 Colors	272.24
A21395-0721	72 Colors, Set A	545.00
A21395-0722	72 Colors, Set B	545.00
A21395-0723	72 Colors, Set C	545.00
A21395-0724	72 Colors, Set D	545.00

36-Color Set

72-Color Set A

72-Color Set B

Copic Original Marker Sets

Open up a whole new world of expression for your drawings with Copic Markers! There's nothing like this marker for blending, painting, and tone control — perfect for fine art, calligraphy, and more. The broad nib offers coverage for larger areas. For detail work, flip over to the fine nib on the opposite end of the marker. Nibs are replaceable for unlimited creative options.

NUMBER	SET	EACH
A22110-0129	12 Colors, Set A	\$90.13
A22110-0369	36 Colors	272.24
A22110-1001	72 Colors, Set A	545.00
A22110-1002	72 Colors, Set B	545.00
A22110-1003	72 Colors, Set C	545.00



ArtBin Marker Storage Satchel

Molded from translucent polypropylene, this handy satchel holds up to 60 of your favorite markers, including Blick, Winsor & Newton, Copic, Prismacolor, and Spectrum Noir. Use the Marker Storage Tray as a free-standing divider in the Storage Satchel — or as an accessory for the Super Satchel, Semi-Satchel, or Double Deep. For details, visit DickBlick.com.

NUMBER	DESCRIPTION	EACH	6/EA
A22747-1010	Satchel	\$26.21	\$23.58
A22747-1020	Tray	10.83	9.74

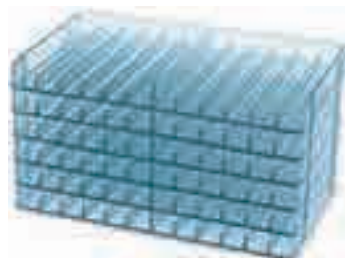

Spectrum Noir Marker Storage Trays

These trays can be used to store any brand of marker (up to 5/8" in diameter), but they're especially useful for horizontal storage of double-ended markers to ensure even ink flow to both ends. Each unit in the six-tray set holds 12 markers — the perfect size to hold two full packs of color-themed Spectrum Noir Markers. Combined, the 5-1/4" x 9-1/2" trays hold a total of 72 markers. The trays come as a single boxed unit but can be customized to suit your space, and used horizontally, vertically, or angled.

NUMBER	COLOR	EACH	3/EA
A00832-2020	Black	\$27.08	\$24.38
A00832-1001	Clear	40.64	36.58

Copic Sketch Marker Trio Sets

Colors blend and fuse in exciting ways with Copic's new Sketch Marker Blending and Color Fusion sets. Two tips (brush and broad) offer outstanding performance for designing, illustrating, cartooning, and more. The alcohol-based ink is fast-drying, permanent, and toner-compatible. Each set contains three markers. For set colors, visit DickBlick.com.

NUMBER	DESCRIPTION	EACH
A21395-1001	Blending Trio 1	\$24.77
A21395-1002	Blending Trio 2	24.77
A21395-1003	Blending Trio 3	24.77
A21395-1004	Blending Trio 4	24.77
A21395-1005	Blending Trio 5	24.77
A21395-1006	Blending Trio 6	24.77
A21395-1007	Blending Trio 7	24.77
A21395-2001	Color Fusion 1	24.77
A21395-2002	Color Fusion 2	24.77
A21395-2003	Color Fusion 3	24.77
A21395-2004	Color Fusion 4	24.77
A21395-2005	Color Fusion 5	24.77
A21395-2006	Color Fusion 6	24.77



A Manuscript Callicreative Flexi Tip Marker Set

Make your mark with Callicreative Flexi Markers! The flexibility of a brush, combined with the precision of a chisel tip, are perfect for hand-lettering and graffiti-style calligraphy. For designers, crafters, lettering artists, or anyone with a creative flair. This set of 12 includes Black, Blue, Brown, Emerald Green, Green Turquoise, Lilac, Orange, Pink, Red, Silver, Sky Blue, and Yellow.

NUMBER	EACH
A00873-1012	\$19.79



B Winsor & Newton ProMarkers

Flawless, even application and coverage makes ProMarkers ideal for design, illustration, comic art, and crafts. Filled with high performance, alcohol-based, permanent ink, they have a broad chisel nib on one end and a rounded bullet nib on the other. Use on paper, cards, glass, acetate, plastic, ceramic, wood, or metal. Secure "click-fit" caps prevent marker dryout.

NUMBER	SET	EACH	6/EA
A24541-1269	6 Metallic	\$29.47	\$26.52
A24541-1169	6 Neon	29.47	26.52
A24541-1069	6 Neutral Tones	29.47	26.52
A24541-1059	6 Pastel Tones	29.47	26.52
A24541-1079	6 Rich Tones	29.47	26.52
A24541-1089	6 Vibrant Tones	29.47	26.52
A24541-1009	13 Manga Chibi Colors	45.05	40.57
A24541-1029	13 Manga Fantasy Colors	45.05	40.57
A24541-1039	13 Manga Steampunk Colors	45.05	40.57
A24541-1219	13 Assorted Colors	45.05	40.57
A24541-2249	24-Color Mixed Marker Wallet	82.37	74.13
A24541-1249	24-Color Student Designer Wallet	82.37	74.13
A24541-1049	48 Essential Colors	163.79	147.41

Individual Markers			
NUMBER	COLOR	EACH	12/EA
A24541-2020	Black	\$6.54	\$5.89
A24541-1001	Blender	6.54	5.89



E Winsor & Newton Promarker Effects

Layer this matte white ink over existing colors to add texture and special effects, or layer under colors to achieve subtle gradations. It can also be used on black or colored paper as its own matte white color.

NUMBER	EACH
A82355-1020	\$6.34

C Touch Twin Brush Marker

Featuring a flexible fiber brush nib on one end and a medium-wide chisel nib on the other, the Touch Twin Brush Marker provides a high degree of control with no smudging or bleeding. The ink is made from purified ethyl alcohol that is non-toxic and virtually odorless. An ergonomically designed body allows multiple grips and a durable nib ensures maximum firmness over time.

NUMBER	DESCRIPTION	SET	EACH
A19929-2069	Fluorescents	6 Colors	\$39.66
A19929-2569	Grey Colors	6 Colors	39.66
A19929-0069	Main Colors	6 Colors	39.66
A19929-1069	Skin Tones	6 Colors	39.66
A19929-5129	Blue-Green Greys	12 Colors	62.04
A19929-2129	Cool Greys	12 Colors	62.04
A19929-0129	Main Colors	12 Colors	62.04
A19929-3129	Pastels	12 Colors	62.04
A19929-1129	Skin Tones	12 Colors	62.04
A19929-2139	Warm Greys	12 Colors	62.04
A19929-8129	Wood Tones	12 Colors	62.04

NUMBER	SET	EACH	
A19929-1024	24 Colors	\$124.08	
NUMBER SET EACH			
A19929-1036	36 Colors	\$182.03	
NUMBER SET EACH			
A19929-1048	48 Colors	\$248.16	
NUMBER DESCRIPTION SET EACH			
A19929-1060	Set A	60 Colors	\$310.00
A19929-2060	Set B	60 Colors	\$310.00

D Copic Doodle Sets

Add color to your doodles and tangle art with Copic Doodle sets. These thoughtfully themed sets come in an assortment of color families, plus a set of rainbow colors. The four-color sets contain two Ciao markers, one Spica glitter pen, and one Multiliner pen. The seven-color sets contain five Ciao markers and two Multiliner pens.

4-Piece Sets			
NUMBER	COLOR	EACH	
A24521-5014	Blue	\$19.80	
A24521-7014	Green	19.80	
A24521-5114	Turquoise	19.80	

7-Piece Sets			
NUMBER	DESCRIPTION	EACH	
A24521-1007	Rainbow	\$34.68	

F Copic Ciao Double Ended Markers

Copic Ciao Double Ended Markers are the perfect choice for beginning artists who want to try markers for the first time. Their solid polypropylene barrels are round, smooth, and smaller than the Copic Sketch Marker's barrel, making them ideal for younger artists. The caps feature an inner seal as well as choke-proof venting. Ciao Markers feature two durable polyester nibs — Super Brush and Medium Broad. Available in 144 colors and carefully selected sets. Recommended for use by children age 12 and older. For open stock colors, visit DickBlick.com. Conforms to ASTM D-4236.

NUMBER	SET	EACH
A22186-0469	6 Brights	\$29.74
A22186-0669	6 Pastels	29.74
A22186-0069	6 Primary	29.74
A22186-0169	6 Sea	29.74
A22186-0269	6 Skin	29.74
A22186-1012	12 Basic	59.50
A22186-0249	24 Colors	118.99
A22186-1036	36 Colors, Set A	178.48
A22186-2036	36 Colors, Set B	178.48
A22186-3036	36 Colors, Set C	178.48
A22186-4036	36 Colors, Set D	178.48
A22186-1072	72 Colors, Set A	357.00
A22186-2072	72 Colors, Set B	357.00

HEALTH & SAFETY ICONS: ●=CL / ■=Prop 65 / ▼=CL & Prop 65
See page 644 for more information.

WARNING! Products marked with a Prop 65 symbol (■ or ▼) can expose you to chemicals, including cadmium, which are known to the State of California to cause cancer and birth defects or other reproductive harm. For more information, visit P65Warnings.ca.gov.

Royal Talens™ Ecoline® Brush Markers

Made from high-quality concentrated dyes in a liquid watercolor base, the low-odor ink in Ecoline Brush Markers is pleasant to use and easy to apply. It mixes cleanly, and adheres well to watercolor paper, drawing paper, and boards. The resilient brush nib is great for covering large areas or drawing very fine details for graphic design, illustration, and lettering applications. They're great for school and home projects, too. Ecoline colors shine especially bright on white or light-colored surfaces. **Colors can be assorted for quantity pricing.**



NUMBER	COLOR	EACH	12/EA
A24543-2020	Black	\$4.27	\$3.84
A24543-1001	Blender	4.27	3.84
A24543-5390	Blue Violet	4.27	3.84
A24543-8710	Burnt Sienna	4.27	3.84
A24543-3510	Carmine	4.27	3.84
A24543-4310	Chartreuse	4.27	3.84
A24543-2520	Gold Grey	4.27	3.84
A24543-7030	Deep Green	4.27	3.84
A24543-3730	Deep Ochre	4.27	3.84
A24543-4910	Deep Orange	4.27	3.84
A24543-4320	Deep Yellow	4.27	3.84
A24543-7270	Forest Green	4.27	3.84
A24543-7010	Green	4.27	3.84
A24543-4060	Lemon Yellow	4.27	3.84
A24543-7020	Light Green	4.27	3.84
A24543-4510	Light Orange	4.27	3.84
A24543-4010	Light Yellow	4.27	3.84
A24543-3040	Magenta	4.27	3.84
A24543-5220	Prussian Blue	4.27	3.84
A24543-8220	Red Brown	4.27	3.84
A24543-3760	Red Violet	4.27	3.84
A24543-3080	Scarlet	4.27	3.84
A24543-8080	Sepia	4.27	3.84
A24543-5590	Sky Blue Cyan	4.27	3.84
A24543-5110	Turquoise Blue	4.27	3.84
A24543-5340	Ultramarine Deep	4.27	3.84
A24543-6730	Ultramarine Violet	4.27	3.84
A24543-3280	Vermilion	4.27	3.84
A24543-2320	Warm Grey	4.27	3.84
A24543-4040	Yellow Ochre	4.27	3.84
NUMBER	SETS	EACH	6/EA
A24543-1009	5 Primary Colors	\$17.45	\$15.71
A24543-1019	10 Colors	40.90	36.80
A24569-1159	15 Colors	49.31	44.38
A24569-1209	20 Colors	64.29	57.87
A24569-1309	30 colors	92.50	57.87

Spectrum Aqua™ Markers

Spectrum Aqua combines the performance of a waterbased medium with the convenience and value of a dual-tipped marker. High-quality dyes assure flawless, even coverage, with all the definition and vibrancy to deliver outstanding results. Ideal for sketching, illustration, manga, comic art, and paper crafts, these markers have both a fine tip for definition and accurate line work, and a brush tip for flexible control. Diffuse with water and seamlessly blend colors to add depth and realism to your work. For set colors, visit DickBlick.com.

NUMBER	DESCRIPTION	EACH	6/EA
A00837-1121	12 Essential	\$33.03	\$29.72
A00837-1122	12 Floral	33.03	29.72
A00837-1120	12 Nature	33.03	29.72
A00837-1123	12 Primary	33.03	29.72



Faber-Castell® Albrecht Dürer Watercolor Markers

Combine classic, fluid watercolor techniques with the precise and intentional lines that markers are famous for. These dual-ended markers have a large brush tip for large areas and a sturdy fiber bullet nib for details. The highly pigmented, odorless, waterbased ink is water-soluble and bleedproof on most high-quality watercolor papers. The colors remain consistent, wet or dry. Made in Germany. **Colors can be assorted for quantity pricing.**

NUMBER	COLOR	EACH	4/EA
A00888-2020	Black	\$5.79	\$5.21
A00888-4200	Cadmium Yellow	5.79	5.21
A00888-7160	Cobalt Green	5.79	5.21
A00888-5920	Cobalt Turquoise	5.79	5.21
A00888-2460	Cold Grey IV	5.79	5.21
A00888-2470	Cold Grey VI	5.79	5.21
A00888-4910	Dark Chrome Yellow	5.79	5.21
A00888-5200	Dark Indigo	5.79	5.21
A00888-7570	Dark Phthalo Green	5.79	5.21
A00888-3260	Deep Scarlet Red	5.79	5.21
A00888-7210	Earth Green	5.79	5.21
A00888-7310	Green Gold	5.79	5.21
A00888-5340	Indanthrene Blue	5.79	5.21
A00888-3250	Indian Red	5.79	5.21
A00888-7150	Leaf Green	5.79	5.21
A00888-3810	Light Flesh	5.79	5.21
A00888-7330	May Green	5.79	5.21
A00888-3720	Middle Purple Pink	5.79	5.21
A00888-4510	Orange Glaze	5.79	5.21
A00888-3710	Pale Geranium Lake	5.79	5.21
A00888-7320	Permanent Green Olive	5.79	5.21
A00888-5160	Phthalo Blue	5.79	5.21
A00888-3740	Pink Carmine	5.79	5.21
A00888-6060	Purple Violet	5.79	5.21
A00888-8520	Sanguine	5.79	5.21
A00888-3080	Scarlet Red	5.79	5.21
A00888-8080	Sepia	5.79	5.21
A00888-5230	Ultramarine	5.79	5.21
A00888-7220	Warm Grey III	5.79	5.21
A00888-7230	Warm Grey IV	5.79	5.21
NUMBER	SET	EACH	6/EA
A00888-1059	5 Colors	\$25.64	\$23.08
A00888-1109	10 Colors	51.24	46.11
A00888-1209	20 Colors	102.38	92.13
A00888-1309	30 Colors	150.82	135.74

NUMBER	SET	EACH	6/EA
A19996-1001	3 Clear Overlays	\$17.99	\$16.21
A19996-1003	3 Glitz & Glamour	17.99	16.21
A19996-1006	3 Metallics	17.99	16.21
A19996-1002	3 Perfect Pastels	17.99	16.21
A19996-1004	3 Shades of Spring	17.99	16.21
A19996-1007	3 Vintage Bloom	17.99	16.21
A19996-1008	3 Vintage Home	17.99	16.21
A19996-1005	3 Winter Warmers	17.99	16.21

Winsor & Newton™ Promarker Watercolor Markers

Beautify your pages with highly pigmented, lightfast color in 36 brilliant shades. Excellent for blending, these markers have both a fine point and flexible brush tip that enable techniques from subtle to precise. Colors mirror and are fully intermixable with Winsor & Newton Professional Watercolors. **Colors can be assorted for quantity pricing.**

NUMBER	COLOR	EACH	12/EA
A00829-3710	Alizarin Crimson Hue	\$5.44	\$4.90
A00829-3120	Burnt Red	5.44	4.90
A00829-8040	Burnt Sienna	5.44	4.90
A00829-8050	Burnt Umber	5.44	4.90
A00829-4530	Cadmium Orange Hue	5.44	4.90
A00829-3540	Cadmium Red Hue	5.44	4.90
A00829-3200	Cadmium Red Deep Hue	5.44	4.90
A00829-3711	Cadmium Red Pale Hue	5.44	4.90
A00829-4350	Cadmium Yellow Hue	5.44	4.90
A00829-4900	Cadmium Yellow Pale Hue	5.44	4.90
A00829-5140	Cerulean Blue	5.44	4.90
A00829-6910	Dioxazine Violet	5.44	4.90
A00829-4500	Gamboge Hue	5.44	4.90
A00829-7910	Hooker's Green	5.44	4.90
A00829-3110	Hooker's Green Dark	5.44	4.90
A00829-5200	Indigo	5.44	4.90
A00829-2250	Ivory Black	5.44	4.90
A00829-2020	Lamp Black	5.44	4.90
A00829-4910	Lemon Yellow Hue	5.44	4.90
A00829-3290	Mauve	5.44	4.90
A00829-5800	Mid Blue	5.44	4.90
A00829-3730	Pale Rose	5.44	4.90
A00829-2660	Payne's Gray	5.44	4.90
A00829-4590	Permanent Rose	5.44	4.90
A00829-5760	Phthlo Blue Red Shade	5.44	4.90
A00829-5160	Phthlo Blue Green Shade	5.44	4.90
A00829-7180	Phthlo Green Yellow Shade	5.44	4.90
A00829-7800	Phthalo Green	5.44	4.90
A00829-5210	Prussian Blue Hue	5.44	4.90
A00829-3620	Quinacridone Magenta	5.44	4.90
A00829-8060	Raw Sienna	5.44	4.90
A00829-8070	Raw Umber	5.44	4.90
A00829-7090	Sap Green	5.44	4.90
A00829-8080	Sepia	5.44	4.90
A00829-5110	Turquoise	5.44	4.90
A00829-4040	Yellow Ochre	5.44	4.90
NUMBER	SET	EACH	6/EA
A00829-1001	6 Basic Colors	\$26.28	\$23.65
A00829-1002	6 Floral Colors	26.28	23.65
A00829-1003	6 Foliage Colors	26.28	23.65
A00829-1004	6 Sky Colors	26.28	23.65
A00829-1005	12 Basic Colors	45.04	40.54
A00829-1006	12 Landscape Colors	45.04	40.54



NUMBER	SET	EACH	6/EA
A19994-8142	Beige	A19994-8142	A19994-8148
A19994-2022	Black	A19994-2022	A19994-2028
A19994-5012	Blue	A19994-5012	A19994-5018
A19994-4292	Bright Yellow	A19994-4292	A19994-4298
A19994-8152	Bronze	A19994-8152	A19994-8158
A19994-8002	Brown	A19994-8002	A19994-8008
A19994-3242	Coral Pink	A19994-3242	—
NUMBER	SET	EACH	6/EA
A19994-7172	Apple Green	A19994-7172	—
A19994-7112	Aqua Green	A19994-7112	—
A19994-3732	Light Pink	A19994-3732	—
A19994-6032	Lilac	A19994-6032	—
A19994-5542	Metallic Blue	A19994-5542	A19994-5548
A19994-7842	Metallic Green	A19994-7842	A19994-7848
A19994-1008	Metallic Pink	A19994-1008	A19994-1012
A19994-3712	Metallic Red	A19994-3712	A19994-3718
A19994-6912	Metallic Violet	A19994-6912	A19994-6918
NUMBER	SET	EACH	6/EA
A19994-7052	Emerald Green	A19994-7052	—
A19994-7278	Fluorescent Green	—	A19994-7278
A19994-4918	Fluorescent Light Orange	—	A19994-4918
A19994-3742	Fluorescent Pink	A19994-3742	A19994-3738
A19994-4652	Fluorescent Orange	A19994-4652	A19994-4658
A19994-3212	Fluorescent Red	A19994-3212	A19994-3218
A19994-4222	Fluorescent Yellow	A19994-4222	A19994-4228
A19994-9012	Gold	A19994-9012	A19994-9018
A19994-7012	Green	A19994-7012	A19994-7018
A19994-2902	Grey	A19994-2902	A19994-2908
A19994-1042	Ivory	A19994-1042	A19994-1048
A19994-5022	Light Blue	A19994-5022	A19994-5028
A19994-7022	Light Green	A19994-7022	A19994-7028
A19994-4522	Light Orange	A19994-4522	A19994-4528
A19994-3732	Light Pink	A19994-3732	—
A19994-6032	Lilac	A19994-6032	—
A19994-5542	Metallic Blue	A19994-5542	A19994-5548
A19994-7842	Metallic Green	A19994-7842	A19994-7848
A19994-1008	Metallic Pink	A19994-1008	A19994-1012
A19994-3712	Metallic Red	A19994-3712	A19994-3718
A19994-6912	Metallic Violet	A19994-6912	A19994-6918
NUMBER	SET	EACH	6/EA
A19994-7052	Emerald Green	A19994-7052	—
A19994-7278	Fluorescent Green	—	A19994-7278
A19994-4918	Fluorescent Light Orange	—	A19994-4918
A19994-3742	Fluorescent Pink	A19994-3742	A19994-3738
A19994-4652	Fluorescent Orange	A19994-4652	A19994-4658
A19994-3212	Fluorescent Red	A19994-3212	A19994-3218
A19994-4222	Fluorescent Yellow	A19994-4222	A19994-4228
A19994-9012	Gold	A19994-9012	A19994-9018
A19994-7012	Green	A19994-7012	A19994-7018
A19994-2902	Grey	A19994-2902	A19994-2908
A19994-1042	Ivory	A19994-1042	A19994-1048
A19994-5022	Light Blue	A19994-5022	A19994-5028
A19994-7022	Light Green	A19994-7022	A19994-7028
A19994-4522	Light Orange	A19994-4522	A19994-4528
A19994-3732	Light Pink	A19994-3732	—
A19994-6032	Lilac	A19994-6032	—
A19994-5542	Metallic Blue	A19994-5542	A19994-5548
A19994-7842	Metallic Green	A19994-7842	A19994-7848
A19994-1008	Metallic Pink	A19994-1008	A19994-1012
A19994-3712	Metallic Red	A19994-3712	A19994-3718
A19994-6912	Metallic Violet	A19994-6912	A19994-6918
NUMBER	SET	EACH	6/EA
A19994-7052	Emerald Green	A19994-7052	—
A19994-7278	Fluorescent Green	—	A19994-7278
A19994-4918	Fluorescent Light Orange	—	A19994-4918
A19994-3742	Fluorescent Pink	A19994-3742	A19994-3738
A19994-4652	Fluorescent Orange	A19994-4652	A19994-4658
A19994-3212	Fluorescent Red	A19994-3212	A19994-3218
A19994-4222	Fluorescent Yellow	A19994-4222	A19994-4228
A19994-9012	Gold	A19994-9012	A19994-9018
A19994-7012	Green	A19994-7012	A19994-7018
A19994-2902	Grey	A19994-2902	A19994-2908
A19994-1042	Ivory	A19994-1042	A19994-1048
A19994-5022	Light Blue	A19994-5022	A19994-5028
A19994-7022	Light Green	A19994-7022	A19994-7028
A19994-4522	Light Orange	A19994-4522	A19994-4528
A19994-3732	Light Pink	A19994-3732	—
A19994-6032	Lilac	A19994-6032	—
A19994-5542	Metallic Blue	A19994-5542	A19994-5548
A19994-7842	Metallic Green	A19994-7842	A19994-7848
A19994-1008	Metallic Pink	A19994-1008	A19994-1012
A19994-3712	Metallic Red	A19994-3712	A19994-3718
A19994-6912	Metallic Violet	A19994-6912	A19994-6918
NUMBER	SET	EACH	6/EA
A19994-7052	Emerald Green	A19994-7052	—
A19994-7278	Fluorescent Green	—	A19994-7278
A19994-4918	Fluorescent Light Orange	—	A19994-4918
A19994-3742	Fluorescent Pink	A19994-3742	A19994-3738
A19994-4652	Fluorescent Orange	A19994-4652	A19994-4658
A19994-3212	Fluorescent Red	A19994-3212	A19994-3218
A19994-4222	Fluorescent Yellow	A19994-4222	A19994-4228
A19994-9012	Gold	A19994-9012	



Artline® Poster Markers

These vivid, waterbased markers are ideal for posters, menu boards, and sign-writing. The highly opaque pigment ink can be applied color-over-color on paper, plastic, plastic foam, wood, glass, rubber, acetate, vinyl, metal, and painted surfaces. Permanent on absorbent surfaces; washes off non-porous surfaces.

Waterproof and fadeproof. Colors can be assorted for quantity pricing.

COLOR	30 MM	20 MM	12 MM	6 MM	4 MM
Black	A22129-2030	A22129-2020	A22129-2012	A22129-2006	A22129-2002
Blue	A22129-5030	A22129-5020	A22129-5012	A22129-5006	A22129-5002
Fluorescent Green	A22129-7230	—	A22129-7212	A22129-7206	A22129-7202
Fluorescent Orange	A22129-4530	—	A22129-4512	A22129-4506	A22129-4502
Fluorescent Pink	A22129-3730	A22129-3720	A22129-3712	A22129-3706	A22129-3702
Fluorescent Yellow	A22129-4230	A22129-4220	A22129-4212	A22129-4206	A22129-4202
Red	A22129-3030	A22129-3020	A22129-3012	A22129-3006	A22129-3002
White	A22129-1030	A22129-1020	A22129-1012	A22129-1006	A22129-1002
	EACH 12/EA	EACH 12/EA	EACH 12/EA	EACH 12/EA	EACH 12/EA
	\$11.58 \$10.42	\$10.47 \$9.43	\$7.66 \$6.90	\$7.66 \$6.90	\$3.95 \$3.56

COLOR	30 MM	20 MM	12 MM
Gold	A22129-9023	A22129-9022	A22129-9021
Silver	A22129-9323	A22129-9322	A22129-9321
	EACH 12/EA	EACH 12/EA	EACH 12/EA
	\$11.58 \$10.42	\$10.47 \$9.43	\$7.66 \$6.90

Artline® Poster Marker 4-Pack Sets

Sets in primary, fluorescent, and metallic colors. Primary sets include one each of Black, Blue, Red, and White; choose from four nib sizes. Fluorescent set includes one each of Yellow, Green, Orange, and Pink. Metallic set includes one each of Blue, Gold, Red, and Silver.

NUMBER	SIZE	SET	EACH	12/EA
A22129-8104	4 mm	Fluorescent	\$15.38	\$13.84
A22129-8204	4 mm	Metallic	15.38	13.84
A22129-8004	4 mm	Primary	15.38	13.84
A22129-9012	12 mm	Primary	29.21	26.29
A22129-9020	20 mm	Primary	41.84	37.66
A22129-9030	30 mm	Primary	46.25	41.63

ZIG® Posterman Paint Markers

These fast-drying, waterbased ink markers can be used on paper, plastic, metal, wood, and stone. The marks they make are permanent on absorbent surfaces, and the colors can be overlapped when dry. They are highly opaque, lightfast, odorless, and non-blurring. Big & Broad Markers make strokes 5/8" or 3/8" wide. Medium Tip Markers make 2 mm (0.08") wide strokes.

NUMBER	SET	EACH	10/EA
A21322-1009	8 Big & Broad	\$64.82	\$58.34
A21322-1109	8 Medium	20.49	18.45



Pentel® Wet Erase Chalk Markers

These chisel-point wet erase chalk markers write on any porous surface. For indoor or outdoor use — dry marker ink will not run when exposed to the elements. All colors wipe clean with a damp cloth. For set contents, visit DickBlick.com. Colors can be assorted for quantity pricing.

COLOR	CHISEL POINT	EACH	12/EA	JUMBO	EACH	12/EA
Black	A22132-2022	\$4.73	\$4.26	A22132-2025	\$8.41	\$7.56
Blue	A22132-5012	4.73	4.26	A22132-5015	8.41	7.56
Green	A22132-7012	4.73	4.26	A22132-7015	8.41	7.56
Orange	A22132-4512	4.73	4.26	A22132-4515	8.41	7.56
Red	A22132-3012	4.73	4.26	A22132-3015	8.41	7.56
Violet	A22132-6512	4.73	4.26	A22132-6515	8.41	7.56
White	A22132-1022	4.73	4.26	A22132-1025	8.41	7.56
Yellow	A22132-4012	4.73	4.26	A22132-4015	8.41	7.56

SETS	NUMBER	DESCRIPTION	EACH	12/EA
	A22132-1009	4 Primary Colors, Chisel Tip	\$18.59	\$16.73
	A22132-1019	4 Secondary Colors, Chisel Tip	18.59	16.73
	A22132-1029	4 Primary Colors, Jumbo Tip	33.13	29.81
	A22132-1039	4 Secondary Colors, Jumbo Tip	33.13	29.81



Marvy® Uchida Bistro Chalk Markers™

Opaque, waterbased, pigmented markers that are great for creating chalkboard art on chalkboards, lightboards, dry-erase boards, windows, and windshields.

Chalk erases easily with a damp cloth. For set contents, visit DickBlick.com.

Colors can be assorted for quantity pricing.

COLOR	EXTRA FINE	6 MM	16 MM
Black	—	A22152-2020	A22152-2025
Blush Pink	—	A22152-3716	—
Blue	—	A22152-5010	—
Brown	—	A22152-8000	—
Fluorescent Blue	A22152-5246	A22152-5240	A22152-5245
Fluorescent Green	A22152-7276	A22152-7270	A22152-7275
Fluorescent Orange	A22152-4566	A22152-4560	A22152-4565
Fluorescent Pink	A22152-3726	A22152-3720	A22152-3725
Fluorescent Red	A22152-3776	A22152-3770	—
Fluorescent Violet	A22152-6916	A22152-6910	A22152-6915
Fluorescent Yellow	A22152-4226	A22152-4220	A22152-4225
Green	—	A22152-7010	—
Pale Violet	—	A22152-6066	—
Pastel Peach	—	A22152-3356	—
Peppermint	—	A22152-2986	—
Red	—	A22152-3010	—
Violet	—	A22152-6510	—
White	A22152-1026	A22152-1020	A22152-1025
Yellow	—	A22152-4010	—
	EACH 6/EA	EACH 6/EA	EACH 6/EA
	\$3.74 \$3.37	\$3.85 \$3.46	\$6.93 \$6.24

EXTRA FINE SETS	NUMBER	SET	EACH	6/EA
	A22152-1011	4 Fluorescent, Set A	\$15.06	\$13.56
	A22152-1012	4 Fluorescent, Set H	15.06	13.56

3 mm SETS	NUMBER	SET	EACH	6/EA
	A22152-1009	2 Metallic	\$6.32	\$5.69
	A22152-1008	4 Metallic	15.06	13.56
	A22152-1005	4 Fluorescent, Set A	15.06	13.56
	A22152-1006	4 Fluorescent, Set H	15.06	13.56
	A22152-1030	4 Pastel	15.06	13.56

6 mm SETS	NUMBER	SET	EACH	6/EA
	A22152-1010	2 Metallic	\$6.32	\$5.69
	A22152-1007	4 Metallic	15.37	13.83
	A22152-1003	4 Colors, Set C	15.37	13.83
	A22152-1004	4 Colors, Set D	15.37	13.83
	A22152-1001	4 Fluorescent, Set A	15.37	13.83
	A22152-1002	4 Fluorescent, Set B	15.37	13.83
	A22152-1060	4 Pastel	15.37	13.83



Elmer's® Painters® Paint Markers

Waterbased and non-toxic, these medium point markers are ideal for children's use and for decorating toys, plaques, and more. They mark on paper, ceramic, wood, plastic, metal, and glass. Colors dry quickly to a permanent, lightfast, opaque finish for both indoor and outdoor use. Colors can be assorted for quantity pricing.

NUMBER	COLOR	EACH	6/EA
A21312-2022	Black	\$4.35	\$3.90
A21312-5012	Blue	4.35	3.90
A21312-8003	Brown	4.35	3.90
A21312-9012	Gold	4.35	3.90
A21312-5043	Navy	4.35	3.90
A22157-3290	Neon Hot Pink	4.39	3.95
A21312-4511	Orange	4.35	3.90
A21312-3012	Red	4.35	3.90
A21312-9302	Silver	4.35	3.90
A21312-1022	White	4.35	3.90
A21312-4012	Yellow	4.35	3.90

For more tip sizes of Elmer's Painters Paint Markers, visit DickBlick.com.



Sharpie® Chalk Markers

Sharpie Chalk Markers are perfect for writing and drawing on chalkboards, glass, whiteboards, ceramics, windows, mirrors, and other non-porous surfaces. Marks wash off easily with a wet cloth.

NUMBER	DESCRIPTION	EACH	12/EA
A82323-1021	White	\$3.79	\$3.41
A82323-1022	2 White	8.68	7.81
A82323-1003	3 Primary Colors	12.69	11.42
A82323-1013	3 Secondary Colors	12.69	11.42
A82323-1005	5 Assorted Colors	17.99	16.19



DecoColor™ Premium Paint Markers

DecoColor Premium Paint Markers produce rich metallic finishes with wonderful opacity. The chisel tip creates both thick and thin lines, indoors or out, on wood, metal, ceramic, glass, sealed plaster, most plastics, most fabrics, and wicker. Great for leafing, too! Lightfast, pigmented metallic colors. Non-toxic.

NUMBER	DESCRIPTION	COLOR	EACH	12/EA
A19989-9502	2 mm	Copper	\$4.18	\$3.76
A19989-9012	2 mm	Gold	4.18	3.76
A19989-9332	2 mm	Silver	4.18	3.76
A19989-9512	2 mm, Leafing Tip	Copper	4.18	3.76
A19989-9022	2 mm, Leafing Tip	Gold	4.18	3.76
A19989-9342	2 mm, Leafing Tip	Silver	4.18	3.76
A19989-9500	Chisel Tip	Copper	4.74	4.27
A19989-9010	Chisel Tip	Gold	4.74	4.27
A19989-9330	Chisel Tip	Silver	4.74	4.27

VersaChalk® Liquid Chalk Markers

Brighter, bolder, and more fun to use than chalk, VersaChalk Markers feature sturdy tips with two distinct ends — bullet and chisel. Just pull out the bullet nib and reinsert it the other way around to make broad strokes with the chisel nib. Can be used on chalkboards, whiteboards, glass, plastic, metal, glazed ceramics, and other non-porous surfaces. Great for classrooms, they're non-toxic, odorless, dust-free, and smear-proof. The set includes eight bright neon colors.

NUMBER	EACH	6/EA
A24578-1001	\$16.52	\$14.86

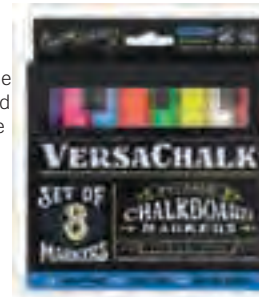

DecoColor™ Paint Markers

Great for signs, posters, and all kinds of crafts because they're solvent-based and dry instantly. Colors may be blended and removed with turpentine. Fully opaque on all porous and non-porous surfaces. Lightfast and weatherproof — excellent for temporary signage. Not rated safe for children. Conforms to ASTM D-4236. Colors can be assorted for quantity pricing.

Ultra Fine Tip	NUMBER	COLOR	Broad Tip	NUMBER	COLOR
	A21337-2201	Black		A21337-2001	Black
	A21337-5201	Blue		A21337-5001	Blue
	A21337-9010	Gold		A21337-3711	Blush Pink
	A21337-7201	Green		A21337-8001	Brown
	A21337-5211	Light Blue		A21337-8111	Copper
	A21337-3251	Pink		A21337-4451	Cream Yellow
	A21337-3201	Red		A21337-3411	Crimson Lake
	A21337-9330	Silver		A21337-8031	Dark Brown
	A21337-6701	Violet		A21337-4051	Gold
	A21337-1020	White		A21337-7001	Green
	A21337-4201	Yellow		A21337-6081	Hot Purple
				A21337-7011	Light Green
				A21337-5011	Light Blue
				A21337-4501	Orange
				A21337-5901	Pale Blue
				A21337-5311	Pale Violet
				A21337-3721	Pastel Peach
				A21337-3701	Peppermint
				A21337-3051	Pink
				A21337-7911	Pine Green
				A21337-6171	Plum
				A21337-3001	Red
				A21337-8911	Rosemarie
				A21337-3461	Rosewood
				A21337-9300	Silver
				A21337-5081	Teal
				A21337-5231	Ultramarine
				A21337-6501	Violet
				A21337-1001	White
				A21337-4001	Yellow

EACH	12/EA	EACH	12/EA
\$3.85	\$3.46	\$4.18	\$3.76

Fine Tip	NUMBER	COLOR	EACH	12/EA
	A21337-2101	Black	\$3.85	\$3.46
	A21337-5101	Blue		
	A21337-8101	Brown		
	A21337-8211	Copper		
	A21337-4151	Gold		
	A21337-7101	Green		
	A21337-5111	Light Blue		
	A21337-7111	Light Green		
	A21337-4601	Orange		
	A21337-3151	Pink		
	A21337-3101	Red		
	A21337-9310	Silver		
	A21337-6601	Violet		
	A21337-1101	White		
	A21337-4101	Yellow		



Sharpie® Waterbased Paint Marker Sets

Waterbased but permanent opaque paint stands out on any color background and will not bleed through paper. Great for mural and poster work, signs, and scrapbooking, they're destined to become a favorite! They're also acid-free, quick-drying, fade-resistant, and water-resistant. Ink is only permanent on paper.

NUMBER	DESCRIPTION	EACH	6/EA
A21397-2003	3 Metallics: Blue, Green, Pink	\$9.99	\$8.99
A21397-2103	3 Metallic Colors: Gold, Silver, Copper	9.99	8.99
A21397-3005	5 Pastels: Blue, Aqua, Peach, Pink, Lavender	17.55	15.79



Pentel® Paint Markers

Perfect for writing and drawing on a variety of surfaces, Pentel Paint Markers have a 4.0 mm bullet tip that creates a 2.0 mm medium line. The opaque, pigmented, oil-based ink produces bright and vivid colors on thick card, metal, glass, ceramic, wood, rubber, and plastic. The ink dries quickly to a permanent finish that resists water, abrasions, and fading. Colors can be assorted for quantity pricing.

NUMBER	COLOR	EACH	12/EA
A24571-2020	Black	\$4.74	\$4.27
A24571-5010	Blue	4.74	4.27
A24571-8000	Brown	4.74	4.27
A24571-9010	Gold	4.74	4.27
A24571-2500	Gray	4.74	4.27
A24571-7010	Green	4.74	4.27
A24571-7020	Light Green	4.74	4.27
A24571-4510	Orange	4.74	4.27
A24571-3060	Pink	4.74	4.27
A24571-3010	Red	4.74	4.27
A24571-9330	Silver	4.74	4.27
A24571-5070	Sky Blue	4.74	4.27
A24571-6510	Violet	4.74	4.27
A24571-1020	White	4.74	4.27
A24571-4010	Yellow	4.74	4.27



Sakura® Pen-Touch™ Paint Markers

Add drama to projects on glass, wood, porcelain, plastic, metal, and paper. Pen-Touch Paint Markers contain quick-drying ink that is permanent on most surfaces. The free-flowing ink formula won't clog the nib. X-Fine markers are 0.7 mm. Fine markers are 1.0 mm. Medium markers are 2.0 mm. Nibs are replaceable. Colors can be assorted for quantity pricing.

COLOR	X-FINE	FINE	MEDIUM
Black	A21326-2027	A21326-2021	A21326-2022
Copper	A21326-9507	A21326-9501	A21326-9502
Gold	A21326-4051	A21326-4055	A21326-9012
Silver	A21326-9300	A21326-9310	A21326-9332
White	A21326-1001	A21326-1005	A21326-1022
	EACH 12/EA	EACH 12/EA	EACH 12/EA
	\$3.52 \$3.17	\$3.52 \$3.17	\$3.52 \$3.17

NUMBER	DESCRIPTION	SIZE	EACH	12/EA
A21326-9327	3 Metallics	X-Fine, 0.7 mm	\$10.95	\$9.86
A21326-9321	3 Metallics	Fine, 1.0 mm	10.95	9.86
A21326-1071	7 Colors	Fine, 1.0 mm	21.61	19.45
A21326-9322	5 Metallics	Medium, 2.0 mm	15.68	14.11
A21326-1052	5 Colors	Medium, 2.0 mm	15.68	14.11

NUMBER	DESCRIPTION	SIZE	EACH	12/EA
A21326-1031	X-Fine, 0.7 mm		\$8.26	\$7.43
A21326-1032	Fine, 1.0 mm		5.50	7.95
A21326-1033	Medium, 2.0 mm		7.36	6.62

Sharpie® Oil-Based Paint Markers

Decorate and add accents to a variety of items including glassware and terra cotta pots with these smooth, no-mess, opaque, oil-based, permanent markers. They're great for touching up wood and metal, personalizing a variety of items and adding pizzazz to school projects. Water-resistant, fade-resistant, and abrasion-resistant. Quick-drying. Colors can be assorted for quantity pricing.

NUMBER	COLOR	EACH	12/EA
A22100-2023	Black	\$6.18	\$5.56
A22100-3013	Red	6.18	5.56
A22100-1023	White	6.18	5.56
A22100-4013	Yellow	6.18	5.56



Medium Point — For broad sweeping lines.

NUMBER	COLOR	EACH	12/EA
A22100-5160	Aqua	\$4.35	\$3.91
A22100-2020	Black	4.35	3.91
A22100-5010	Blue	4.35	3.91
A22100-8000	Brown	4.35	3.91
A22100-7010	Green	4.35	3.91
A22100-7230	Lime	4.35	3.91
A22100-3040	Magenta	4.35	3.91
A22100-4510	Orange	4.35	3.91
A22100-3060	Pink	4.35	3.91
A22100-6000	Purple	4.35	3.91
A22100-3010	Red	4.35	3.91
A22100-1020	White	4.35	3.91
A22100-4010	Yellow	4.35	3.91
A22100-9010	Metallic Gold	4.35	3.91
A22100-9330	Metallic Silver	4.35	3.91



Set of 5 Assorted Medium Point Markers —

Includes Black, Gold, Red, Silver, and White.

Set of 5 Assorted Medium Point Fashion Markers — Includes Aqua, Lime, Orange, Pink, and Purple.

Set of 8 Assorted Medium Point Markers — Includes Aqua, Black, Lime Green, Magenta, Orange, Red, White and Yellow.

NUMBER	EACH	6/EA
A22100-0059	\$16.88	\$15.19
A22100-1059	\$16.88	\$15.19
A22100-1001	\$23.31	\$20.98

Fine Point — For detailed work and touch up.

NUMBER	COLOR	EACH	12/EA
A22100-5161	Aqua	\$4.16	\$3.74
A22100-2021	Black	4.16	3.74
A22100-5011	Blue	4.16	3.74
A22100-8001	Brown	4.16	3.74
A22100-7011	Green	4.16	3.74
A22100-7231	Lime	4.16	3.74
A22100-3041	Magenta	4.16	3.74
A22100-4511	Orange	4.16	3.74
A22100-3061	Pink	4.16	3.74
A22100-6001	Purple	4.16	3.74
A22100-3011	Red	4.16	3.74
A22100-1021	White	4.16	3.74
A22100-4011	Yellow	4.16	3.74
A22100-9331	Metallic Silver	4.16	3.74
A22100-9011	Metallic Gold	4.16	3.74



Extra Fine Point — Perfect for ultra-precise lines.

NUMBER	COLOR	EACH	12/EA
A22100-2022	Black	\$4.16	\$3.74
A22100-5012	Blue	4.16	3.74
A22100-7012	Green	4.16	3.74
A22100-3012	Red	4.16	3.74
A22100-1022	White	4.16	3.74
A22100-4012	Yellow	4.16	3.74
A22100-9012	Metallic Gold	4.16	3.74
A22100-9332	Metallic Silver	4.16	3.74



Molotow® ONE4ALL™ Acrylic Markers

ONE4ALL — the name stands for versatility and the most innovative, revolutionary paint system in the world. This highly pigmented, solvent-free, UV-resistant hybrid paint covers nearly every indoor or outdoor surface and can be applied with any tool, including markers, brushes, and airbrushes. Refills available at DickBlick.com. Colors can be assorted for quantity pricing.

COLOR	1.5 MM	2 MM	BULLET 4 MM	CHISEL 4-8 MM	15 MM
Amazonas Light	A19910-4705	A19910-4702	A19910-4704	—	—
Blue Violet Pastel	A19910-5605	A19910-5602	A19910-5604	—	—
Burgundy	A19910-3105	A19910-3102	A19910-3104	—	A19910-3115
Calypto Middle	—	A19910-1182	A19910-1184	—	—
Ceramic Light Pastel	A19910-1905	A19910-1902	A19910-1904	—	A19910-1915
Cool Grey Pastel	A19910-2805	A19910-2802	A19910-2804	—	A19910-2815
Currant	A19910-6805	A19910-6802	A19910-6804	—	A19910-6815
Dare Orange	A19910-4505	A19910-4502	A19910-4504	—	A19910-4515
Fuchsia Pink	—	A19910-3062	A19910-3064	—	—
Future Green	A19910-7205	A19910-7202	A19910-7204	—	—
Grasshopper	A19910-7305	A19910-7302	A19910-7304	—	—
Grey Blue Dark	—	A19910-5872	A19910-5874	—	—
Grey Blue Light	—	A19910-5862	A19910-5864	—	—
Hazelnut	A19910-8905	A19910-8902	A19910-8904	—	A19910-8915
Lago Blue Pastel	A19910-5305	A19910-5302	A19910-5304	—	A19910-5315
Lagoon Blue	A19910-5705	A19910-5702	A19910-5704	—	—
Lilac Pastel	A19910-6305	A19910-6302	A19910-6304	—	A19910-6315
Lobster	A19910-1705	A19910-1702	A19910-1704	—	—
Magenta	—	A19910-3042	A19910-3044	—	—
Metallic Black	A19910-2095	A19910-2092	A19910-2094	—	—
Metallic Blue	A19910-5505	A19910-5502	A19910-5504	—	—
Metallic Gold	A19910-9205	A19910-9202	A19910-9204	—	—
Metallic Light Green	A19910-7805	A19910-7802	A19910-7804	—	—
Metallic Pink	A19910-3705	A19910-3702	A19910-3704	—	—
Metallic Silver	A19910-9305	A19910-9302	A19910-9304	—	—
Mister Green	A19910-7105	A19910-7102	A19910-7104	—	A19910-7115
Nature White	—	A19910-1372	A19910-1374	—	—
Neon Green Fluor	A19910-7705	A19910-7702	A19910-7704	—	—
Neon Orange Fluor	A19910-4405	A19910-4402	A19910-4404	—	—
Neon Pink	A19910-3605	A19910-3602	A19910-3604	—	A19910-3615
Neon Pink Fluor	A19910-3405	A19910-3402	A19910-3404	—	—
Neon Yellow Fluor	A19910-4205	A19910-4202	A19910-4204	—	—
Ochre Brown Light	A19910-8205	A19910-8202	A19910-8204	—	—
Peach Pastel	A19910-3305	A19910-3302	A19910-3304	—	A19910-3315
Petrol	A19910-5805	A19910-5802	A19910-5804	—	—
Poison Green	—	A19910-7152	A19910-7154	—	—
Purple Violet	—	A19910-6062	A19910-6064	—	—
Sahara Beige Pastel	A19910-8105	A19910-8102	A19910-8104	—	—
Shock Blue	—	A19910-5922	A19910-5924	—	—
Shock Blue Middle	A19910-5905	A19910-5902	A19910-5904	A19910-5948	A19910-5915
Signal Black	A19910-2005	A19910-2002	A19910-2004	A19910-2048	A19910-2015
Signal White	A19910-1605	A19910-1202	A19910-1204	A19910-1248	A19910-1215
Skin Pastel	A19910-3505	A19910-3502	A19910-3504	—	—
Traffic Red	A19910-3905	A19910-3902	A19910-3904	A19910-3948	A19910-3915
True Blue	A19910-5205	A19910-5202	A19910-5204	—	A19910-5215
Turquoise	—	A19910-5112	A19910-5114	—	—
Universes Green	A19910-7605	A19910-7602	A19910-7604	—	—
Vanilla Pastel	A19910-1505	A19910-1502	A19910-1504	—	A19910-1515
Violet Dark	A19910-6605	A19910-6602	A19910-6604	—	—
Zinc Yellow	A19910-4905	A19910-4902	A19910-4904	A19910-4948	A19910-4915
	EACH 6/EA	EACH 6/EA	EACH 6/EA	EACH 6/EA	EACH 6/EA
	\$8.47 \$7.62	\$8.40 \$7.56	\$9.37 \$8.43	\$15.99 \$14.39	\$17.69 \$15.92

Empty Markers	1.5 MM	2 MM	BULLET 4 MM	CHISEL 4-8 MM	15 MM
	—	A19910-1002	A19910-1004	A19910-1048	A19910-1015
		EACH 6/EA	EACH 6/EA	EACH 6/EA	EACH 6/EA
		\$5.29 \$4.76	\$5.99 \$5.35	\$9.65 \$8.68	\$7.99 \$7.19

NUMBER	COLOR	SIZE	EACH	6/EA
A19910-1009	6 Colors	2 mm	\$43.65	\$39.29
A19910-1019	6 Colors	4 mm	52.19	46.98
A19910-9322	6 Metallics	2 mm	43.65	39.29
A19910-9324	6 Metallics	4 mm	52.19	46.98
A19910-1102	6 Neon	2 mm	43.65	39.29
A19910-1104	6 Neon	4 mm	52.19	46.98

A Molotow® GrafX™ Art Masking Liquid Pump Markers

A must-have for artists, these ready-to-use, refillable markers contain a water-repellant masking fluid that applies cleanly and rubs off easily, leaving no residue. Molotow's patented pump delivery system assures precise, mess-free application and sharp edges. Use with your favorite Molotow markers, airbrushes, acrylic paints — even ultra-opaque, alcohol-based permanent inks. No brush required!

NUMBER	SIZE	EACH	12/EA
A00834-1002	2 mm	\$12.81	\$11.53
A00834-1004	4 mm	13.94	12.55

B Molotow® Speedflow and CoversAll Markers

Speedflow and CoversAll Markers feature Molotow's patented Flowmaster pump-valve that ensures a continuous ink flow for quick application on larger areas. Perfect for indoor and outdoor use, the alcohol-based inks are permanent, high-covering, UV-resistant, weather-resistant, quick-drying, and abrasion-resistant. For best results, refill with CoversAll and Speedflow refills. For additional sizes, visit DickBlick.com.

NUMBER	COLOR	SIZE	EACH	6/EA
A19910-1148	Speedflow Black	4-8 mm, Chisel	\$14.83	\$13.35
A19910-1160	Speedflow Black	60 mm	19.92	17.93
A19910-1360	CoversAll Signal Black	60 mm	20.03	18.03





Liquitex® Paint Markers

These outstanding, professional-quality, waterbased acrylic markers are formulated using artist-grade pigments. Permanent and lightfast, they're available in a wide selection of brilliant colors (visit DickBlick.com for color range). Precision nibs in two sizes offer ultimate control. All of the colors match the Liquitex color spectrum and are compatible with other Liquitex products. Suitable for both indoor and outdoor use, they can be used on a wide range of surfaces, including primed canvas, wood, masonry, metal, and glass. Lightfast-rated ASTM I or II (except for the fluorescent colors).

Colors can be assorted for quantity break pricing.

COLOR	2 MM	EACH	6/EA	15 MM	EACH	6/EA
Bright Aqua Green	A19919-7202	\$6.60	\$5.94	A19919-7201	\$9.91	\$8.92
Brilliant Blue	A19919-5062	6.60	5.94	A19919-5061	9.91	8.92
Brilliant Purple	A19919-6022	6.60	5.94	A19919-6021	9.91	8.92
Bronze Yellow	A19919-4912	6.60	5.94	A19919-4911	9.91	8.92
Burnt Sienna	A19919-8042	6.60	5.94	A19919-8041	9.91	8.92
Burnt Umber	A19919-8052	6.60	5.94	A19919-8051	9.91	8.92
Cadmium Orange Hue	A19919-4542	6.60	5.94	A19919-4541	9.91	8.92
Cadmium Red Dp Hue	A19919-3712	6.60	5.94	A19919-3711	9.91	8.92
Cadmium Red Lt Hue	A19919-3182	6.60	5.94	A19919-3181	9.91	8.92
Cadmium Red Med Hue	A19919-3232	6.60	5.94	A19919-3231	9.91	8.92
Cadmium Ylw Dp Hue	A19919-4282	6.60	5.94	A19919-4281	9.91	8.92
Cadmium Ylw Lt Hue	A19919-4132	6.60	5.94	A19919-4131	9.91	8.92
Cadmium Ylw Med Hue	A19919-4192	6.60	5.94	A19919-4191	9.91	8.92
Carbon Black	A19919-2122	6.60	5.94	A19919-2121	9.91	8.92
Cerulean Blue Hue	A19919-5172	6.60	5.94	A19919-5171	9.91	8.92
Cobalt Blue Hue	A19919-5192	6.60	5.94	A19919-5191	9.91	8.92
Cobalt Turquoise Hue	A19919-5372	6.60	5.94	A19919-5371	9.91	8.92
Dioxazine Purple	A19919-6012	6.60	5.94	A19919-6011	9.91	8.92
Emerald Green	A19919-7052	6.60	5.94	A19919-7051	9.91	8.92
Fluorescent Blue	A19919-5242	6.60	5.94	A19919-5241	9.91	8.92
Fluorescent Green	A19919-7272	6.60	5.94	A19919-7271	9.91	8.92
Fluorescent Orange	A19919-4562	6.60	5.94	A19919-4561	9.91	8.92
Fluorescent Pink	A19919-3742	6.60	5.94	A19919-3741	9.91	8.92
Fluorescent Red	A19919-3732	6.60	5.94	A19919-3731	9.91	8.92
Fluorescent Yellow	A19919-4222	6.60	5.94	A19919-4221	9.91	8.92
Hooker's Grn Hue Perm	A19919-7712	6.60	5.94	A19919-7711	9.91	8.92
Iridescent Antique Gold	A19919-9102	6.60	5.94	A19919-9101	9.91	8.92
Iridescent Rich Silver	A19919-9382	6.60	5.94	A19919-9381	9.91	8.92
Light Blue Permanent	A19919-5092	6.60	5.94	A19919-5091	9.91	8.92
Light Blue Violet	A19919-5382	6.60	5.94	A19919-5381	9.91	8.92
Light Green Permanent	A19919-7552	6.60	5.94	A19919-7551	9.91	8.92
Light Portrait Pink	A19919-3722	6.60	5.94	A19919-3721	9.91	8.92
Light Violet	A19919-6532	6.60	5.94	A19919-6531	9.91	8.92
Medium Magenta	A19919-3312	6.60	5.94	A19919-3311	9.91	8.92
Naples Yellow Hue	A19919-4242	6.60	5.94	A19919-4241	9.91	8.92
Neutral Gray 5	A19919-2052	6.60	5.94	A19919-2051	9.91	8.92
Neutral Gray 7	A19919-2072	6.60	5.94	A19919-2071	9.91	8.92
Neutral Gray 8	A19919-2082	6.60	5.94	A19919-2081	9.91	8.92
Parchment	A19919-7382	6.60	5.94	A19919-7381	9.91	8.92
Phth Blue (BS)	A19919-5942	6.60	5.94	A19919-5941	9.91	8.92
Phth Blue (GS)	A19919-5752	6.60	5.94	A19919-5751	9.91	8.92
Prussian Blue Hue	A19919-5222	6.60	5.94	A19919-5221	9.91	8.92
Quinacridone Crimson	A19919-3782	6.60	5.94	A19919-3781	9.91	8.92
Raw Sienna	A19919-8062	6.60	5.94	A19919-8061	9.91	8.92
Raw Umber	A19919-8072	6.60	5.94	A19919-8071	9.91	8.92
Titanium White	A19919-1022	6.60	5.94	A19919-1021	9.91	8.92
Unbleached Titanium	A19919-1092	6.60	5.94	A19919-1091	9.91	8.92
Vivid Lime Green	A19919-7872	6.60	5.94	A19919-7871	9.91	8.92
Yellow Medium Azo	A19919-4602	6.60	5.94	A19919-4601	9.91	8.92
Yellow Oxide	A19919-4112	6.60	5.94	A19919-4111	9.91	8.92

Molotow™ Liquid Chrome Markers

Create high-gloss mirrored effects with these unique, alcohol-based markers. Released in celebration of Molotow's 20th anniversary, Liquid Chrome Markers are great for creating a mirror finish on smooth, non-absorbent surfaces such as glass or plastic. The paint is highly opaque and permanent with good UV-resistance, and the low-odor formula makes the markers pleasant to use both inside and out. Molotow's patented Flowmaster technology assures consistent paint flow. Available in four nib sizes and a refill. Made in Germany.

NUMBER	DESCRIPTION	EACH	6/EA
A19995-1001	1 mm	\$12.90	\$11.61
A19995-1002	2 mm	12.90	11.61
A19995-1004	4 mm	15.21	13.69
A19995-1005	5 mm	23.95	21.55
A19995-1030	Refill, 30 ml	38.57	34.72



X-Fine

Medium

Pilot® Gold and Silver Marking Pens

Waterproof and permanent on any surface, the ink in Pilot Marking Pens is available in shining Silver or gleaming Gold.

NUMBER	COLOR	EACH	12/EA	24/EA
A20704-4055	Gold X-Fine	\$3.85	\$3.53	\$3.33
A20704-9300	Silver X-Fine	3.85	3.53	3.33
A20704-9010	Gold Medium Point	3.85	3.53	3.33
A20704-9330	Silver Medium Point	3.85	3.53	3.33



Krylon® Leafing Pens

Add metallic accents that resemble metal plating to any surface. Use on wood, metal, wicker, plastic, glass, foam, plaster, ceramic, fabric, paper, and more. Chisel tip draws thick or thin lines. Paint is touch-dry within 10 minutes and can be handled safely within two hours. Acid-free and archival.

NUMBER	COLOR	EACH	6/EA	12/EA
A22171-9010	18k Gold	\$9.63	\$8.67	\$8.24
A22171-9330	Silver	9.63	8.67	8.24
A22171-9200	Rose Gold	9.63	8.67	8.24

Krink® K-55 Paint Markers

Filled with waterbased ink that is xylene-free, solvent-free, and odor-free, the Krink K-55 Paint Marker is perfect for inside use where fumes are undesirable. Available in Black, Red, and Silver, the K-55 also comes in a range of fluorescent colors that glow in black light environments. The K-55's extra-broad, valve-action chisel tip is excellent for creating thin or thick bands of vivid color, particularly large calligraphy work. Handmade in the USA. Colors can be assorted for quantity pricing.

NUMBER	COLOR	EACH	6/EA
A19920-2020	Black	\$16.63	\$14.97
A19920-5010	Fluorescent Blue	16.63	14.97
A19920-7010	Fluorescent Green	16.63	14.97
A19920-4510	Fluorescent Orange	16.63	14.97
A19920-3060	Fluorescent Pink	16.63	14.97
A19920-4010	Fluorescent Yellow	16.63	14.97
A19920-3010	Red	16.63	14.97
A19920-9330	Silver	16.63	14.97



Primary Set of 6 — Titanium White, Carbon Black, Cadmium Red Medium Hue, Cadmium Yellow Medium Hue, Emerald Green, and Brilliant Blue.

NUMBER	COLOR	SIZE	EACH	6/EA
A19919-2069	6 Primary	2 mm	\$33.06	\$29.76
A19919-1569	6 Primary	15 mm	45.50	40.95

Fluorescent Set of 6 — Fluorescent Green, Fluorescent Blue, Fluorescent Red, Fluorescent Pink, Fluorescent Orange, and Fluorescent Yellow.

NUMBER	COLOR	SIZE	EACH	6/EA
A19919-1109	6 Fluorescent	2 mm	\$33.06	\$29.76
A19919-1009	6 Fluorescent	15 mm	45.50	40.95

Vibrant Set of 6 — Cadmium Yellow Light Hue, Cadmium Orange Hue, Medium Magenta, Brilliant Purple, Light Blue Permanent, and Vivid Lime Green.

NUMBER	COLOR	SIZE	EACH	6/EA
A19919-1079	6 Vibrant	2 mm	\$33.06	\$29.76
A19919-1069	6 Vibrant	15 mm	45.50	40.95



DecoColor™ Acrylic Paint Markers

These pigmented, waterbased acrylic paint markers are ideal for all your crafting needs. Lightfast and permanent when dry, they clean up easily while wet. Chisel point allows fine lines and broad strokes. Choose from a wide variety of colors or four-color sets. Colors can be assorted for quantity pricing.

COLOR	5 MM	EACH	6/EA	15 MM	EACH	6/EA
Aquamarine	A22151-5360	\$3.95	\$3.56	—	—	—
Aubergine	A22151-7130	3.95	3.56	—	—	—
Black	A22151-2020	3.95	3.56	A22193-2020	\$6.93	\$6.24
Blue	A22151-5010	3.95	3.56	A22193-5010	6.93	6.24
Brown	A22151-8000	3.95	3.56	A22193-8000	6.93	6.24
Bubble Gum	A22151-3720	3.95	3.56	—	—	—
Celadon	A22151-7480	3.95	3.56	—	—	—
Celery	A22151-7710	3.95	3.56	—	—	—
English Red	A22151-3740	3.95	3.56	—	—	—
Gold	A22151-9010	3.95	3.56	A22193-9010	6.93	6.24
Green	A22151-7010	3.95	3.56	A22193-7010	6.93	6.24
Jade Green	A22151-7240	3.95	3.56	—	—	—
Light Blue	A22151-5020	3.95	3.56	—	—	—
Light Green	A22151-7020	3.95	3.56	—	—	—
Metallic Blue	A22151-5540	3.95	3.56	—	—	—
Metallic Green	A22151-7840	3.95	3.56	—	—	—
Metallic Red	A22151-3710	3.95	3.56	—	—	—
Metallic Violet	A22151-6910	3.95	3.56	—	—	—
Orange	A22151-4510	3.95	3.56	—	—	—
Pale Orange	A22151-4500	3.95	3.56	—	—	—
Pink	A22151-3060	3.95	3.56	—	—	—
Pumpkin	A22151-4620	3.95	3.56	—	—	—
Red	A22151-3010	3.95	3.56	A22193-3010	6.93	6.24
Silver	A22151-9330	3.95	3.56	A22193-9330	6.93	6.24
Violet	A22151-6510	3.95	3.56	—	—	—
White	A22151-1020	3.95	3.56	A22193-1020	6.93	6.24
Wisteria	A22151-6190	3.95	3.56	—	—	—
Yellow	A22151-4010	3.95	3.56	A22193-4010	6.93	6.24

NUMBER	SET	EACH	6/EA
A22151-1001	Primary	\$15.94	\$14.35
A22151-1002	Bright	15.94	14.35
A22151-1003	Metallic	15.94	14.35



Sakura® Permapaque® Opaque Paint Markers

Safe, no-mess opaque paint markers that you don't need to shake. Non-toxic, quick-drying, odorless, permanent, and suitable for acid-free environments. Each marker has two points: a chisel point on one end for both detail and wider coverage, and a bullet point on the other end. Colors can be assorted for quantity pricing.

NUMBER	COLOR	EACH	12/EA	24/EA
A21377-5000	Blue	\$3.94	\$3.55	\$3.37
A21377-8000	Brown	3.94	3.55	3.37
A21377-7000	Green	3.94	3.55	3.37
A21377-4500	Orange	3.94	3.55	3.37
A21377-4200	Pale Orange	3.94	3.55	3.37
A21377-6000	Purple	3.94	3.55	3.37
A21377-3000	Red	3.94	3.55	3.37
A21377-5070	Sky Blue	3.94	3.55	3.37
A21377-4000	Yellow	3.94	3.55	3.37
A21377-4750	Yellow Green	3.94	3.55	3.37



Krink® K-42 Paint Markers

Krink K-42 Paint Markers feature high-quality, opaque, pigmented ink that can be used on metal, canvas, painted surfaces, wood, glass, plastic, and paper. The paint is permanent, quick-drying, fade-resistant, and water-resistant — great for art, craft, and industrial use. Recyclable aluminum barrels. Xylene-free. Handmade in the USA. Conforms to ASTM D-4236.

Colors can be assorted for quantity pricing.

NUMBER	COLOR	EACH	12/EA
A22182-2020	Black	\$8.71	\$7.84
A22182-5010	Blue	8.71	7.84
A22182-7010	Green	8.71	7.84
A22182-4510	Orange	8.71	7.84
A22182-3060	Pink	8.71	7.84
A22182-6000	Purple	8.71	7.84
A22182-3010	Red	8.71	7.84
A22182-9330	Silver	8.71	7.84
A22182-1020	White	8.71	7.84
A22182-4010	Yellow	8.71	7.84



Montana® Acrylic Markers

These brilliant, waterbased, pigmented, matte colors are compatible with and match the colors in the Montana Gold spray paint range. The ink is lightfast, waterproof, abrasion-proof, and can be applied to almost any surface, including canvas, wood, metal, walls, and glass. It's also ideal for brushwork and airbrush use. The optimum flow control pump valve system allows accurate handling and application.

EXTRA FINE	COLOR	NUMBER	COLOR	FINE	COLOR	NUMBER	COLOR
A19907-3760	Iron Curtain	A19907-3760	Iron Curtain	A19907-3761	Iron Curtain	A19907-3761	Iron Curtain
A19907-9511	Matte Copper	A19907-9511	Matte Copper	A19907-9512	Matte Copper	A19907-9512	Matte Copper
A19907-9001	Matte Gold	A19907-9001	Matte Gold	A19907-9002	Matte Gold	A19907-9002	Matte Gold
A							



Ultra-Fine Fine Chisel



BIC® Marking Permanent Marker Sets

BIC's Marking Permanent Markers are great for hard-to-mark surfaces, including glass, metal, photos, foils, coated paper, and most plastics. The acid-free ink comes in a variety of bold, fashionable colors. An ultra-comfy textured grip lends comfort and control.

NUMBER	SET	EACH	6/EA
A22165-1012	12 Assorted	\$10.63	\$9.57
A22165-1024	24 Assorted	20.63	18.57
A22165-1036	36 Assorted Fine	27.96	25.17
A22165-2036	36 Assorted Ultra-Fine	27.96	25.17

NUMBER	SET	EACH	6/EA
A22165-1149	4 Assorted	\$6.11	\$5.50

NUMBER	COLOR	EACH	12/EA
A22165-2020	Black	\$1.09	\$9.98
A22165-5010	Blue	1.09	.98
A22165-3010	Red	1.09	.98

NUMBER	COLOR	EACH	12/EA
A24526-2021	Black	\$1.35	\$1.21



BIC® Marking Permanent Metallic Marker Sets

Add a metallic sparkle on porous surfaces such as paper and cardboard with these metallic marker sets. Markers have a contemporary barrel design and an ultra-comfy rubber grip. Set of 8 includes Platinum Silver, Yellow Gold, Emerald Green, Sapphire, Amethyst, Jade, Pink Topaz, and Bronze.

NUMBER	SET	EACH	6/EA
A22165-1089	8 Assorted	\$12.89	\$11.60
A22165-1002	2 Metallic (Gold/Silver)	5.67	5.10

A Sharpie® Pens

The Sharpie Pen makes bold marks like only a Sharpie can, but the ink won't bleed through your paper! The durable extruded plastic tip assures line-width consistency, and the fine point delivers crisp lines and precise writing. The quick-drying, permanent ink resists smears, water, and fading.

NUMBER	COLOR	EACH	12/EA	24/EA
A21881-2020	Black	\$2.31	\$2.09	\$1.97
A21881-5010	Blue	2.31	2.09	1.97

Fine Point Set of 4 — Includes one each of Black, Blue, Red, and Green.

NUMBER	EACH	6/EA	12/EA
A21881-5049	\$9.68	\$8.71	\$8.27

A Fine Point 6-Count New Colors Pack — Turquoise, Clover, Coral, Orange, Hot Pink, and Purple.

NUMBER	EACH	6/EA	12/EA
A21881-1006	\$13.57	\$12.21	\$11.60

Fine Point 6-Count Assorted Pack — Black, Blue, Green, Orange, Purple, and Red.

NUMBER	EACH	6/EA	12/EA
A21881-1069	\$13.57	\$12.21	\$11.60

Fine Point 12-Count Assorted Pack — Turquoise, Green, Clover, Watermelon, Orange, Hot Pink, Red, Purple, and two each of Black and Blue.

NUMBER	EACH	6/EA	12/EA
A21881-1012	\$28.60	\$25.74	\$24.45

B Sharpie® Art Pens

Sharpie Art Pens make bold, vivid marks, and they won't bleed through paper! Unique extruded plastic tips assure durability and line-width consistency, and fine points deliver crisp, precise lines. Sets come in a hard case, convenient for storage and transport. The caps match the ink color.

NUMBER	SET	EACH	6/EA
A22591-1089	8 Assorted	\$22.79	\$20.51
A22591-1169	16 Assorted	36.61	32.95
A22591-1249	24 Assorted	42.37	38.14

C Sharpie® Chisel Tip Markers

Make broad or fine lines with Sharpie Chisel Tip Markers. The ink is permanent and waterproof, and a unique non-roll barrel offers improved control.

NUMBER	COLOR	EACH	12/EA	24/EA
A21383-2020	Black	\$1.35	\$1.22	\$1.15
A21383-5000	Blue	1.35	1.22	1.15
A21383-7000	Green	1.35	1.22	1.15
A21383-3000	Red	1.35	1.22	1.15

NUMBER	SET	EACH	12/EA	24/EA
A21383-0089	8 Assorted	\$11.50	\$10.34	\$9.82

D Super Sharpie® Markers

A bold, fine tip for making impressive marks. Ink is quick-drying, fade-resistant, and water-resistant.

NUMBER	COLOR	EACH	12/EA	24/EA
A21203-2001	Black	\$2.19	\$1.97	\$1.87
A21203-3001	Red	2.19	1.97	1.87

E Sharpie® King Size™ Markers

This big, durable marker was engineered for rugged use. It has a 5-1/4" x 7/8" Dia aluminum barrel and a broad, three-way wedge tip. The permanent ink flows on any surface and dries instantly. Color-coded leakproof cap fits in base during use. Colors can be assorted for quantity pricing.

NUMBER	COLOR	EACH	12/EA	24/EA
A21323-2005	Black	\$2.11	\$1.86	\$1.75
A21323-5005	Blue	2.11	1.86	1.75
A21323-3005	Red	2.11	1.86	1.75

F Sharpie® Magnum® Markers

For the really big jobs! Excellent for making fast signs, amateur and professional signmakers alike enjoy the versatility of both 5/8" and 3/8" wide line options with this giant wedge tip. The quick-drying, permanent ink is highly water-resistant. Colors can be assorted for quantity pricing.

NUMBER	COLOR	EACH	12/EA	24/EA
A21336-2005	Black	\$4.85	\$4.47	\$4.03
A21336-5005	Blue	4.85	4.47	4.03
A21336-3005	Red	4.85	4.47	4.03

STAEDTLER® Lumocolor Markers

A universal pen that writes on almost any surface including photos, printers' proofs, glass, vinyl, and overhead transparencies. Smudge-resistant and waterproof for long-lasting marks with neutral-smelling ink that dries in seconds. Dry Safe technology allows these markers to be uncapped for days without drying out. Colors can be assorted for quantity pricing.

NUMBER	COLOR	SIZE	EACH	12/EA	24/EA
A21338-2101	Black	Fine	\$2.31	\$2.08	\$1.98
A21338-2002	Black	Medium	2.31	2.08	1.98
A21338-2001	Black	Broad	2.31	2.08	1.98
A21338-5481	Blue	Fine	2.31	2.08	1.98
A21338-3071	Red	Fine	2.31	2.08	1.98

NUMBER	SIZE	EACH	6/EA	12/EA
A21338-0409	Super Fine	\$9.19	\$8.27	\$7.86
A21338-0419	Fine	9.19	8.27	7.86
A21338-0049	Medium	9.19	8.27	7.86

4-Color Set — Includes Black, Blue, Green, and Red.

NUMBER	SIZE	EACH	6/EA	12/EA
A21338-0809	Fine	\$18.73	\$16.86	\$16.03
A21338-0819	Medium	18.73	16.86	16.03

8-Color Set — Includes Black, Blue, Brown, Green, Orange, Red, Violet, and Yellow.

NUMBER	SIZE	EACH	6/EA	12/EA
A20835-0009	Superfine	\$11.65	\$10.49	\$9.97
A20835-0000	Fine	11.65	10.49	9.97
A20835-1009	Medium	11.65	10.49	9.97

Non-Permanent — These 4-color sets include Black, Blue, Green, and Red.

NUMBER	SIZE	EACH	6/EA	12/EA
A21315-2159	5 Mystic Gem Colors	\$6.35	\$5.70	\$5.42
A21315-1089	8 Colors	8.19	7.39	6.99
A21315-1249	24 Colors	24.80	22.35	21.25
A21315-3249	24 Colors w/Color Burst	24.80	22.35	21.25
A21315-2129	12 Mystic Gem Colors	12.29	11.05	10.50
A21315-4249	24 Mystic Gem Colors	24.80	22.35	21.25

G Sharpie® Metallic Markers

Sharpie Metallic Markers are designed to create brilliant, permanent marks on both light and dark surfaces. Their bold, smooth, no-shake performance is available in a variety of metallics, including Silver, Gold, and Bronze.

NUMBER	COLOR	EACH	12/EA	24/EA
A21388-9890	Bronze	\$2.49	\$2.24	\$2.11
A21388-9430	Gold	2.49	2.24	2.11
A21388-9331	Metallic Silver	2.49	2.24	2.11

Pack of 2 Markers

NUMBER	COLOR	EACH	3/EA	6/EA
A22126-9322	Metallic Silver	\$4.64	\$4.18	\$3.97
A21388-9020	Metallic Gold	4.64	4.18	3.97

Pack of 3 Markers

NUMBER	DESCRIPTION	EACH	3/EA	6/EA
A21388-1039	Bronze, Gold, Silver	\$6.74	\$5.73	\$5.44
A21388-1309	Emerald, Ruby, Sapphire	6.74	6.07	5.77

Pack of 6 Markers — Bronze, Emerald, Gold, Ruby, Sapphire, and Silver

NUMBER	EACH	3/EA	6/EA
A21388-1069	\$16.53	\$14.88	\$14.14

Canister of 36

NUMBER	COLOR	EACH	3/EA	6/EA
A21388-9336	Silver	\$59.90	\$53.91	\$51.21

H Sharpie® Twin Tip Marker

Fine tip and ultra fine tip in one pen! The famous Sharpie marker is permanent, waterproof, and marks on glass, metal, photos, foil, paper, and most plastics.

NUMBER	COLOR	EACH	12/EA	24/EA
A21373-2020	Black	\$2.65	\$2.38	\$2.26

Set of 8 — Includes Aqua, Berry, Burgundy, Marigold, Navy, Plum, Olive, and Turquoise.

NUMBER	EACH	3/EA	6/EA
A21373-1089	\$21.23	\$19.11	\$18.15

Sharpie® Retractable Markers

The same great Sharpie ink in a retractable, fine-point marker offers hassle-free, one-handed operation! No more lost caps, and the safety seal valve prevents dry-out. Permanent, quick-drying ink marks on most hard-to-mark surfaces including glass and stone.

NUMBER	COLOR	EACH	12/EA	24/EA
A21399-2020	Black	\$3.49	\$3.14	\$2.98
A21399-7010	Green	3.49	3.14	2.98
A21399-3010	Red	3.49	3.14	2.98

I-K Sharpie® Ultra-Fine Point Marker Sets

Personalize your drawings, labels, and more with color! 0.3 mm tip with a plastic clip.

NUMBER	SET	EACH	6/EA	12/EA
A21315-2159	5 Mystic Gem Colors	\$6.35	\$5.70	\$5.42
A21315-1089	8 Colors	8.19	7.39	6.99
A21315-1249	24 Colors	24.80	22.35	21.25
A21315-3249	24 Colors w/Color Burst	24.80	22.35	21.25
A21315-2129	12 Mystic Gem Colors	12.29	11.05	10.50
A21315-4249	24 Mystic Gem Colors	24.80	22.35	21.25

Sharpie® Ultra-Fine Point Markers

An ultra-fine (0.3 mm) point provides a crisp, fine line. Durable nibs withstand heavy use and the water-resistant permanent ink adheres to almost any surface. Ideal for writing, labeling, drawing, and more. Plastic clip. Colors can be assorted for quantity pricing.

NUMBER	COLOR	EACH	12/EA	24/EA
A21315-5151	Aqua	\$1.25	\$1.13	\$1.05
A21315-3711	Berry	1.25	1.13	1.05
A21315-2003	Black	1.25	1.13	1.05
A21315-5003	Blue	1.25	1.13	1.05
A21315-8001	Brown	1.25	1.13	1.05
A21315-7003	Green	1.25	1.13	1.05
A21315-6030	Lilac	1.25	1.13	1.05
A21315-3040	Magenta	1.25	1.13	1.05
A21315-4501	Orange	1.25	1.13	1.05
A21315-6001	Purple	1.25	1.13	1.05
A21315-2980	Racey Red	1.25	1.13	1.05
A21315-3003	Red	1.25	1.13	1.05
A21315-5111	Turquoise	1.25	1.13	1.05

Sharpie® Fine Point Markers

A tough, resilient 0.5 mm tip produces a quick-flow ink that is fast-drying, water-resistant, and permanent. Colors can be assorted for quantity pricing.

NUMBER	COLOR	EACH	12/EA	24/EA
A21316-5150	Aqua	\$1.25	\$1.13	\$1.05
A21316-3710	Berry	1.25	1.13	1.05
A21316-2001	Black	1.25	1.13	1.05
A21316-5001	Blue	1.25	1.13	1.05
A21316-8001	Brown	1.25	1.13	1.05
A21316-7001	Green	1.25	1.13	1.05
A21316-6030	Lilac	1.25	1.13	1.05
A21316-7230	Lime	1.25	1.13	1.05
A21316-3040	Magenta	1.25	1.13	1.05
A21316-4501	Orange	1.25	1.13	1.05
A21316-3060	Pink	1.25	1.13	1.05
A21316-6001	Purple	1.25	1.13	1.05
A21316-3001	Red	1.25	1.13	1.05
A21316-5070	Sky	1.25	1.13	1.05
A21316-5110	Turquoise	1.25	1.13	1.05
A21316-4001	Yellow	1.25	1.13	1.05

L Sharpie® Fine Point Marker Sets

Mark almost anything with bright, lasting color.

NUMBER	SET	EACH	6/EA	12/EA
--------	-----	------	------	-------



A Marvy® Le Plume II™ Dual-Tipped Markers

Quite possibly the finest markers you'll ever own, these waterbased markers have an extra-fine nib on one end and a brush marker on the other. Made to stay wet longer than the average marker, Le Plume markers are perfect for brushing on rubber stamps and producing an evenly colored stamp. Available in specially selected sets to suit your color needs. Acid-free, non-toxic, in a plastic snap-shut case.

NUMBER	SET	EACH	6/EA
A21228-1029	12 Basic	\$31.96	\$28.77
A21228-1039	12 Bright	31.96	28.77
A21228-1059	12 Garden	31.96	28.77
A21228-1019	Colorless Blender	2.85	2.57

B Pentel Arts® Color Brush™ Pens

Pentel's Brush Pen has a flexible nylon tip that is ideal for stylized design work, oriental artwork, calligraphy, and cartoons. The ink is valve-activated for a smooth flow without leaking. Enjoy a variety of lines, from fine detail to broad, sweeping strokes.

Waterbased Liquid Dye Ink — Brightly colored ink dries quickly and produces translucent watercolor effects.

NUMBER	COLOR	EACH	5/EA
A22890-2010	Black	\$9.10	\$8.20
A22890-2502	Gray	9.10	8.20
A22890-3012	Red	9.10	8.20
A22890-8090	Sepia	9.10	8.20

NUMBER	COLOR	EACH	5/EA
A22890-2022	Black Refill, 2 pack	\$5.46	\$4.91



Pigment Ink — This intense, concentrated ink produces rich black tones. Permanent, acid-free, fadeproof, and water-resistant.

NUMBER	COLOR	SIZE	EACH	5/EA
A24528-2020	Black	Fine	\$9.25	\$8.33
A22504-2020	Black	Medium	9.03	8.11
A22504-2022	Black Refill, 2-pack		5.50	4.95



Brush

E Copic® Multiliner SP Pens

Updated Multiliners feature a durable aluminum body and unique tips to create distinctive line variations. Waterproof, pigment-based ink provides a consistent ink flow for easy, crisp lines. Refillable with replaceable nibs.

NUMBER	SIZE	EACH
A22127-2003	0.03 mm	\$11.54
A22127-2005	0.05 mm	11.54
A22127-2101	0.1 mm	11.54
A22127-2102	0.2 mm	11.54
A22127-2025	0.25 mm	11.54
A22127-2103	0.3 mm	11.54
A22127-2035	0.35 mm	11.54
A22127-2105	0.5 mm	11.54
A22127-2107	0.7 mm	11.54
A22127-2000	Brush	11.54

10-Count Set — All 10 sizes, including 0.03, 0.05, 0.1, 0.2, 0.25, 0.3, 0.35, 0.5, 0.7, and Brush.

NUMBER	EACH
A22127-9998	\$104.44

C Lyra™ Aqua Brush Duo Sets

The Aqua Brush Duo is a waterbased ink pen that was especially developed for artists and designers. The outstanding properties of the dual tips enable users to produce beautiful brush effects — ideal for laying down fine lines and shading large areas of color in pictures and layouts.

NUMBER	SET	EACH	6/EA
A20874-1012	12 Assorted	\$35.43	\$31.89
A20874-1024	24 Assorted	72.33	65.10



D Tombow® Dual Brush™ Pens

Two tips — a flexible nylon fiber brush tip and a fine-point, hard nylon tip — allow fine, medium, or bold brushstrokes and consistent lines. Pens contain blendable, waterbased, odorless ink. For our complete selection of open stock pens, visit DickBlick.com.

NUMBER	SET	EACH	6/EA
A21334-2000	1 Black	\$3.18	\$2.90
A21334-1179	10 Bright	22.86	20.56
A21334-1039	10 Citrus	22.86	20.56
A21334-1049	10 Desert Flora	22.86	20.56
A21334-1249	10 Galaxy	22.86	20.56
A21334-1159	10 Grey Scale	22.86	20.56
A21334-1139	10 Landscape	22.86	20.56
A21334-1199	10 Muted	22.86	20.56
A21334-1239	10 Pastel	22.86	20.56
A21334-1149	10 Portrait	22.86	20.56
A21334-1119	10 Primary	22.86	20.56
A21334-1129	10 Secondary	22.86	20.56
A21334-1259	10 Tropical	22.86	20.56
A21334-1209	20 Florals	47.83	43.04
A21334-1229	20 Neutrals	47.83	43.04
A21334-1219	20 Perfect Blends	47.83	43.04
A21334-1189	108 Colors	298.99	269.09

F Copic® Multiliners

These permanent, waterproof-pigment Multiliner pens won't bleed into Copic markers. Ideal for scrapbooking, comic design, and illustration, these precision drawing pens create distinctive line variations.

NUMBER	COLOR	SET	EACH
A21396-1079	Black	7 Asst Nibs, A-2	\$28.06
A21396-1099	Black	9 Asst Nibs, B-2	34.16
A21396-2049	Black	4 Fine Nibs	16.21
A21396-2149	Black	4 Broad Nibs	16.21
A21396-2549	Gray	4 Fine Nibs	16.21
A21396-8149	Sepia	4 Fine Nibs	16.21



Sargent Art® Classic Brush Tip Markers

Great for school or home, these durable markers with flexible brush tips come in a variety of vibrant, long-lasting colors — ideal for fluid illustrations and writing. For age 3+.

NUMBER	SET	EACH	12/EA
A22362-1012	12 Assorted	\$4.37	\$3.95
A22362-1020	20 Assorted	5.92	5.33

HEALTH & SAFETY ICONS: ●=CL / ■=Prop 65 / ▼=CL & Prop 65
See page 644 for more information.



G Sakura® Koi® Coloring Brush Pens

These flexible brush markers contain a dye-based transparent ink that blends easily to create a multitude of hues. They're great for graphic artists, designers, illustrators, and students. Fine, medium, or bold strokes are easy to achieve, simply by varying the pressure on the brush nib.

NUMBER	DESCRIPTION	EACH	6/EA
A19902-2020	Individual Black	\$2.75	\$2.47
A19902-1002	2 Blenders	4.57	4.11
A19902-2509	6 Grays	13.67	12.31
A19902-0129	12 Assorted	28.99	26.10
A19902-0249	24 Assorted	55.98	50.39
A19902-0489	48 Assorted	111.83	100.70

H Artline® Drawing Pens

Super-thin line is great for technical applications such as drafting, illustrating, and graphic design. Friction-proof nib offers a consistent writing width. Metal-reinforced collar nib stands up to ruler and template work without nib damage. Water-resistant, fadeproof black ink is xylene-free. RoHS-compliant.

NUMBER	SIZE	EACH	12/EA	24/EA
A22128-2005	0.05 mm	\$2.09	\$1.88	\$1.79
A22128-2021	0.1 mm	2.09	1.88	1.79
A22128-2022	0.2 mm	2.09	1.88	1.79
A22128-2023	0.3 mm	2.09	1.88	1.79
A22128-2024	0.4 mm	2.09	1.88	1.79
A22128-2025	0.5 mm	2.09	1.88	1.79
A22128-2026	0.6 mm	2.09	1.88	1.79
A22128-2027	0.7 mm	2.09	1.88	1.79
A22128-2028	0.8 mm	2.09	1.88	1.79

Set of 3 — Includes 0.1 mm, 0.3 mm, and 0.5 mm writing widths.

NUMBER	EACH	12/EA	24/EA
A22128-1039	\$7.41	\$6.67	\$6.34

Set of 6 — Includes 0.1 mm, 0.2 mm, 0.3 mm, 0.4 mm, 0.5 mm, and 0.8 mm writing widths.

NUMBER	EACH	12/EA	24/EA
A22128-1069	\$13.06	\$11.75	\$11.17



I Marabu Aqua Pen Graphix

For watercolor painting on watercolor paper, Marabu Aqua Pen Graphix provides high-quality, lightfast, waterbased pigment ink in dozens of brilliant colors. Use the two tips (one for contours and the other a flexible brush tip) to apply color, then use a wet brush to spread it. A low-odor formula makes these pens a pleasure to use. Note: Never dip pens into water. For set colors, visit DickBlick.com.

NUMBER	DESCRIPTION	EACH	6/EA
A24547-1029	6 King of Bubblegum	\$15.17	\$13.65
A24547-1019	6 Ma Ke Manga	15.17	13.65
A24547-1039	6 Metropolitan	15.17	13.65
A24547-1009	12 Mega Mash	25.27	22.75
A24547-1049	25 Octopy	46.53	41.88

J Crayola® No Drip Washable Paint Brush Pens

The fun of painting without the mess. Unique design means a smooth flow of paint with no squeezing. Colors wash from skin and most clothing. The 5-count set includes Red, Yellow, Green, Blue, and Purple. The 40-count set includes five each of Brown, Red, Orange, Yellow, Green, Blue, Violet, and Black.

NUMBER	SET	EACH	6/EA
A20875-1005	5 Assorted	\$5.93	\$5.34
A20875-1040	40 Assorted	43.37	39.03



K Karin Brushmarker Pro Markers

Great for drawing, illustration, and design, these markers are equipped with flexible, super-durable nylon tips that are twice as efficient as the tips in traditional filter markers. A proprietary liquid ink technology maintains the ink's color intensity down to the last drop. The dye-based colors (the neon colors are pigment-based) can be mixed and lightened to achieve tonal transitions.

NUMBER	DESCRIPTION	EACH
A82306-1129	12 Basic Colors	\$30.17
A82306-1003	12 Flower Colors	30.17
A82306-2500	12 Grays	30.17
A82306-2129	12 Piece Set	30.17
A82306-1004	12 Skin Colors	30.17
A82306-1001	12 Sky Colors	30.17
A82306-1002	12 Sun and Tree Colors	30.17
A82306-1627	27 Piece Set	56.39
A82306-1639	63 Piece Set	109.99



L Kingart Dual Tip Brush Pen Sets

Vibrant and versatile, these durable pens have two brush tips for creating every width of brushstroke for hand lettering, calligraphy, illustrations, journaling, doodling, and more. Waterbased ink blends easily. Use two or more markers to create unique shades and the colorless blender pen for watercolor effects.

NUMBER	DESCRIPTION	EACH	6/EA
A24576-1249	24 Colors	\$17.13	\$15.42
A24576-1489	48 Colors	27.54	24.79

M Pentel® Arts™ Color Pens™

These markers have an acrylic tip with a fine point specially designed for art and illustration. Non-toxic, waterbased ink.

NUMBER	SET	EACH	12/EA	24/EA
A21211-0129	12 Assorted	\$13.14	\$11.82	\$11.23
A21211-0189	18 Assorted	14.56	13.09	12.45
A21211-0249	24 Assorted	18.41	16.55	15.72
A21211-0369	36 Assorted	27.13	24.40	23.16

N Pentel Arts® Sign Brush Pen Sets

Richly saturated colors are fully blendable with water and each other. The waterbased dye ink is bright and intense. Dilute the tip with water to get a full range of values. Every pen has a wear-resistant, pressure-sensitive, flexible tip for creating different techniques, including feathering, cross-hatching, outlining, calligraphy, and detailed line work. Secure snap-tight caps prevent dryout when left uncapped. Caps can be cleaned easily with a paper towel.

NUMBER	SET	EACH	12/EA
A22585-1016	6 Fashion	\$12.94	\$11.64
A22585-1012	6 Primary	36.92	33.23



O Kuretake Zig® Fudebiyori Metallic Brush Pens

Add metallic accents to your work with Fudebiyori Brush Pens. The metallic colors are especially effective on dark-colored papers, and the flexible brush tip is great for creating details or for filling in larger areas. The waterbased, waterproof pigments are acid-free, photo-safe, and lightfast. Odorless and xylene-free.

NUMBER	COLOR	EACH	12/EA	24/EA
A00833-2020	Black	\$2.73	\$2.46	\$2.34
A00833-5010	Blue	2.73	2.46	2.34
A00833-9500	Copper	2.73	2.46	2.34
A00833-9010	Gold	2.73	2.46	2.34
A00833-7010	Green	2.73	2.46	2.34
A00833-3010	Red	2.73	2.46	2.34
A00833-9330	Silver	2.73	2.46	2.34
A00833-6060	Violet	2.73	2.46	2.34

Set of 8 — Includes Gold, Silver, Green, Copper, Violet, Blue, Red, and Black.

NUMBER	EACH	6/EA	12/EA
A00833-1008	\$21.87	\$19.68	\$18.71

WARNING! Products marked with a Prop 65 symbol (■ or ▼) can expose you to chemicals, including cadmium, which are known to the State of California to cause cancer and birth defects or other reproductive harm. For more information, visit P65Warnings.ca.gov.



Stabilo® Point 88® Pens

These 0.4 mm pens feature waterbased ink in vibrant colors. A metal-encased tip extends life and makes the pens suitable for use with rulers and stencils. High cap-off time — won't dry out quickly. For set contents, visit DickBlick.com.

NUMBER	SET	EACH	10/EA
A21859-1006	6 Colors	\$8.08	\$7.26
A21859-1010	10 Colors	11.33	10.19
A21859-1159	15 Colors	16.33	14.70
A21859-1020	20 Colors	24.03	21.62
A21859-1025	25 Colors	24.80	22.33
A21859-1030	30 Colors	32.69	29.43
A21859-1008	8 Pastels	8.67	7.80
A21859-1018	8 Shades of Red	8.67	7.80
A21859-1028	8 Shades of Blue	8.67	7.80

A Kingart™ Inkline™ Artist Pen Set

Inkline Artist Pens are filled with vibrant, permanent ink. Waterproof, fadeproof, and archival, the ink won't feather, skip, blot, or bleed



through most papers. The fine tip pens in this 16-pen set draw precise lines, and the brush tip pen combines the precision of a fine tip pen with the expressive power of an artist's brush. Great for illustration, calligraphy, freehand artwork, and technical drawing.

NUMBER	SET	STYLE	EACH	12/EA
A00887-1008	8 Assorted Colors	Brush Tip	\$9.78	\$8.80
A00887-1018	8 Assorted Colors	Fine Tip	9.78	8.80
A00887-1169	16 Assorted Colors	Assorted	29.28	26.35
A00887-2026	6 Black	Fine Tip	13.45	12.10
A00887-2021	10 Black	Assorted Tips	14.69	13.22

B Tombow® TwinTone Dual Tip Markers

These double-ended markers give you two tip choices — a broad bullet tip (0.8 mm) for bold lines and an extra-fine tip (0.3 mm) for detailed, precise lines. Perfect for color-coding and decorating planners, journals, and notebooks, they're great for lettering, stenciling, and doodling, too. They contain vibrant waterbased ink that won't bleed through most papers. The durable, long-lasting fiber points maintain their shape with repeated use.



NUMBER	SET	EACH	6/EA
A00859-1002	12 Pastel	\$19.22	\$17.30
A00859-1001	12 Bright	19.22	17.30



C Edding® 55 Fineliners

Ideal for writing, sketching, illustrating, and layouts, Edding 55 Fineliners have a 0.3 mm nib and an extended metal neck — great for technical drawing. The waterbased ink is watersoluble until dry, and won't bleed through most papers.

NUMBER	DESCRIPTION	EACH	24/EA
A21070-1109	10 Colors	\$13.43	\$12.09
A21070-1169	16 Colors	20.99	18.89

D Derwent® Paint Pens

Create layers, dribbles, washes, and fine lines with Line Painters. They issue fluid, opaque pigment ink from a .05 mm Japanese nib, offering an immense depth of color, even on dark backgrounds. Use a brush to blend and create effects. Choose from 20 exciting colors and sets. The permanent waterbased ink is solvent-free. For set contents, visit DickBlick.com. Colors can be assorted for quantity pricing.

Individual Painters

NUMBER	COLOR	EACH	12/EA
A00830-1018	Black	\$5.83	\$5.25
A00830-1009	Bright Blue	5.83	5.25
A00830-1002	Chrome	5.83	5.25
A00830-1016	Concrete	5.83	5.25
A00830-1005	Cranberry	5.83	5.25
A00830-1008	Dark Blue	5.83	5.25
A00830-1017	Graphite 17	5.83	5.25
A00830-1014	Leaf Green	5.83	5.25
A00830-1001	Lemon Yellow	5.83	5.25
A00830-1006	Magenta	5.83	5.25
A00830-1013	Mid Green	5.83	5.25
A00830-1012	Mint Green	5.83	5.25
A00830-1011	Ocean Blue	5.83	5.25
A00830-1004	Primary Red	5.83	5.25
A00830-1003	Scarlet	5.83	5.25
A00830-1010	Sea Green	5.83	5.25
A00830-1020	Silver	5.83	5.25
A00830-1015	Terracotta	5.83	5.25
A00830-1007	Violet	5.83	5.25
A00830-1019	White	5.83	5.25

Set #1



Sets

NUMBER	DESCRIPTION	EACH	6/EA
A00830-1519	Palette #1, 5 Colors	\$25.74	\$23.17
A00830-1529	Palette #2, 5 Colors	25.74	23.17
A00830-1539	Palette #3, 5 Colors	25.74	23.17
A00830-1549	Palette #4, 5 Colors	25.74	23.17

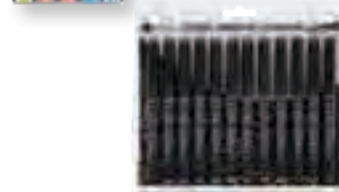

E Manuscript® CalliCreative Italic Marker Sets

Add color to your calligraphy projects with CalliCreative Markers. These versatile markers feature long-lasting tips, ergonomic comfort grips, and washable inks that make them ideal for crafters and artists of all ages. Sets of 12 markers are available in broad (3.6 mm) or fine (1.4 mm) tips. For set contents, visit DickBlick.com.

NUMBER	DESCRIPTION	EACH	6/EA
A20991-1009	12 Colors, Broad	\$21.42	\$19.28
A20991-1109	12 Colors, Fine	21.42	19.28

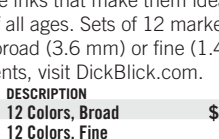
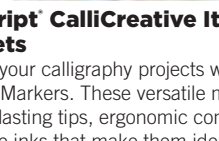

F Derwent® Line Makers

Build tone in your drawings with pens that work like a graphic pencil. Featuring rich, pure, waterbased pigment ink and Japanese nibs in a range of sizes, Line Makers lay down smooth, free-flowing lines, perfect for illustration. Quick-drying, lightfast, and solvent-free. Colors can be assorted for quantity pricing.

NUMBER	COLOR	SIZE	EACH	12/EA
A22574-2020	Black	0.05 mm	\$4.29	\$3.86
A22574-2021	Black	0.1 mm	4.29	3.86
A22574-2022	Black	0.2 mm	4.29	3.86
A22574-2023	Black	0.3 mm	4.29	3.86
A22574-2025	Black	0.5 mm	4.29	3.86
A22574-2028	Black	0.8 mm	4.29	3.86
A22574-2191	Graphite	0.1 mm	4.29	3.86
A22574-2193	Graphite	0.3 mm	4.29	3.86
A22574-2195	Graphite	0.5 mm	4.29	3.86
A22574-8081	Sepia	0.1 mm	4.29	3.86
A22574-8083	Sepia	0.3 mm	4.29	3.86
A22574-8085	Sepia	0.5 mm	4.29	3.86

Sets

NUMBER	DESCRIPTION	EACH	6/EA
A22574-2029	3 Black	\$11.54	\$10.39
A22574-2199	3 Graphite	11.54	10.39
A22574-8089	3 Sepia	11.54	10.39
A22574-1069	6 Assorted Colors, 0.3mm	15.53	13.98
A22574-2026	6 Black	23.99	21.60

G Marvy® Uchida® LePen™

A winner for more than a quarter of a century, LePen is unrivaled for its unique microfine synthetic point and sleek, lightweight barrel design. Every LePen fine-line marker features a 0.3 mm point and vivid, acid-free, smudgeproof ink. Conforms to ASTM D-4236. For set contents, visit DickBlick.com.

Colors can be assorted for quantity pricing.

NUMBER	COLOR	EACH	12/EA
A20841-3710	Amethyst	\$1.78	\$1.60
A20841-2020	Black	1.78	1.60
A20841-5010	Blue	1.78	1.60
A20841-8000	Brown	1.78	1.60
A20841-3150	Burgandy	1.78	1.60
A20841-2530	Dark Gray	1.78	1.60
A20841-7010	Green	1.78	1.60
A20841-6040	Lavender	1.78	1.60
A20841-5020	Light Blue	1.78	1.60
A20841-7020	Light Green	1.78	1.60
A20841-7070	Olive Green	1.78	1.60
A20841-4510	Orange	1.78	1.60
A20841-6420	Orchid	1.78	1.60
A20841-5890	Oriental Blue	1.78	1.60
A20841-5770	Periwinkle	1.78	1.60
A20841-3060	Pink	1.78	1.60
A20841-3010	Red	1.78	1.60
A20841-5110	Teal	1.78	1.60



NUMBER	DESCRIPTION	EACH	6/EA
A20841-1009	10 Assorted	\$16.89	\$15.20
A20841-1029	10 Bright	16.89	15.20
A20841-1019	10 Dark	16.89	15.20
A20841-1039	10 Neon	16.89	15.20

For more Marvy® Uchida® LePen™ Sets, visit DickBlick.com.



H Art Alternatives™ Finesline Pen Sets

Use these fine line pens for drawing, illustrating, and coloring on paper, board, or canvas. They're perfect for coloring books, too. Precision 0.4 mm tips excel at creating fine details and working with rulers and templates. Waterbased ink comes in a variety of vibrant colors. Triangular barrel is easy to grip.

NUMBER	SET	EACH	6/EA
A21022-1129	12 Assorted	\$7.67	\$6.90
A21022-1249	24 Assorted	14.44	12.99
A21022-1369	36 Assorted	21.38	19.24
A21022-1489	48 Assorted	28.89	25.99

I Pilot® Bravo! Marker Pens

Bold point marker pen with smooth liquid ink technology is great for labeling and identifying. Waterbased ink won't bleed through paper. Visible ink supply won't dry out if left uncapped. Colors can be assorted for quantity pricing.

NUMBER	COLOR	EACH	12/EA	24/EA
A21860-2020	Black	\$2.50	\$2.25	\$2.14
A21860-5010	Blue	2.50	2.25	2.14
A21860-3010	Red	2.50	2.25	2.14

J Pilot® Razor Point Pens

A unique liquid ink produces crisp, fine (0.3 mm) lines through an extra-tough plastic point. Barrels are color-coded with the ink color. Colors can be assorted for quantity pricing.

NUMBER	COLOR	EACH	12/EA
A20703-2001	Black	\$1.92	\$1.72
A20703-5001	Blue	1.92	1.72
A20703-6001	Purple	1.92	1.72
A20703-3001	Red	1.92	1.72

K Pilot® V-Razor Extra-Fine Point Marker Pens

Smooth writing from the first word to the end of the page with Pilot's unique liquid ink formula and extra-tough plastic point. Distinctive modern design. Also available as an eight-color set. For set contents, visit DickBlick.com. Colors can be assorted for quantity pricing.

NUMBER	COLOR	EACH	12/EA
A20775-2021	Black	\$2.30	\$2.07
A20775-5001	Blue	2.30	2.07
A20775-3001	Red	2.30	2.07

NUMBER	DESCRIPTION	EACH	12/EA
A20775-1089	8-Color Set	\$19.81	\$17.83



L STAEDTLER® Triplus Fineline Pens

Ergonomically designed for comfortable drawing and writing. Super-fine 0.3 mm porous points have protective metal-clad tips. Acid-free, non-permanent "dry-safe ink" won't dry out even if pen is left uncapped for several days. Colors can be assorted for quantity pricing.

NUMBER	SET	EACH	10/EA
A21817-0169	6 Neon	\$10.41	\$9.37
A21817-1269	6 Summer Festival	10.41	9.37
A21817-1169	6 Urban Escape	10.41	9.37
A21817-0109	10 Assorted	20.39	18.35
A21817-0209	20 Assorted	31.96	28.76
A21817-1489	48 Assorted	46.57	41.91

Individual Colors

NUMBER	COLOR	EACH	10/EA
A21817-5160	Aqua	\$1.78	\$1.58
A21817-2020	Black	1.78	1.58
A21817-5010	Blue	1.78	1.58
A21817-8000	Brown	1.78	1.58
A21817-5590	Cyan	1.78	1.58
A21817-3720	Dark Mauve	1.78	1.58
A21817-7080	French Green	1.78	1.58
A21817-7010	Green	1.78	1.58
A21817-2500	Grey	1.78	1.58
A21817-5020	Light Blue	1.78	1.58
A21817-7020	Light Green	1.78	1.58
A21817-3040	Magenta	1.78	1.58
A21817-7070	Olive Green	1.78	1.58
A21817-4510	Orange	1.78	1.58
A21817-3060	Pink	1.78	1.58
A21817-3010	Red	1.78	1.58
A21817-2510	Silver Grey	1.78	1.58
A21817-8310	VanDyck Brown	1.78	1.58
A21817-6510	Violet	1.78	1.58
A21817-4010	Yellow	1.78	1.58

M STAEDTLER® Triplus® Color Pens

The Triplus Color Pen has a pressure-resistant 1.0 mm fiber tip and an ergonomic triangular shape for relaxed, easy writing and coloring. The waterbased ink washes easily out of most textiles. Dry Safe technology means the pens won't dry out even when left uncapped for days. Ventilated safety cap.

NUMBER	SET	EACH	5/EA
A00856-1009	15 Assorted	\$17.14	\$15.43
A00856-1019	32 Assorted	37.62	33.86

N Paper Mate® Flair® Pens

Designed to last longer than most felt tip pens, this pen features a reinforced Point Guard tip to prevent tip spread. Medium point tip (1.1 mm) delivers bold, smooth lines. Colors can be assorted for quantity pricing.

NUMBER	COLOR	EACH	12/EA
A20771-2020	Black	\$2.49	\$2.24
A20771-5000	Blue	2.49	2.24
A20771-7000	Green	2.49	2.24
A20771-6000	Purple	2.49	2.24
A20771-3000	Red	2.49	2.24



Paper Mate® Flair® Pen Sets

Flair felt-tip pens deliver bold, expressive lines. The ink is fast-drying and acid-free, and a point guard prevents the tip

SAKURA

Sakura Pigma Micron Pens

Artists, writers, and illustrators reach for Pigma Micron to convey their personality, style, or ability, and to safeguard their work with the lasting quality of Pigma ink. Ideal for paper crafts, journals, illustration, crafts, or any application requiring precision and permanence. Acid-free and archival.

COLOR	0.15 MM (003)	0.20 MM (005)	0.25 MM (01)	0.30 MM (02)	0.35 MM (03)	0.45 MM (05)	0.50 MM (08)	EACH	6/EA
Black	A20702-2153	A20702-2102	A20702-2002	A20702-2103	A20702-2003	A20702-2004	A20702-2005	\$2.87	\$2.57
Blue	—	A20702-5102	A20702-5001	A20702-5002	A20702-5003	A20702-5004	A20702-5005	2.87	2.57
Black/Blue	—	—	—	—	—	A20702-2094	—	2.87	2.57
Brown	—	A20702-8010	A20702-8011	—	—	A20702-8015	—	2.87	2.57
Burgundy	—	—	—	—	—	A20702-3144	—	2.87	2.57
Fresh Green	—	—	—	—	—	A20702-7234	—	2.87	2.57
Green	—	A20702-7012	A20702-7001	A20702-7013	A20702-7003	A20702-7005	A20702-7008	2.87	2.57
Hunter Green	—	—	—	—	—	A20702-7504	—	2.87	2.57
Orange	—	A20702-4512	A20702-4511	—	—	A20702-4515	—	2.87	2.57
Purple	—	A20702-6000	A20702-6001	—	—	A20702-6005	—	2.87	2.57
Red	—	A20702-3006	A20702-3001	A20702-3002	A20702-3003	A20702-3005	A20702-3008	2.87	2.57
Rose	—	A20702-3710	A20702-3711	—	—	A20702-3715	—	2.87	2.57
Royal Blue	—	—	—	—	—	A20702-5054	—	2.87	2.57
Sepia	A20702-8083	—	A20702-8081	—	—	A20702-8084	—	2.87	2.57
Yellow	—	—	—	—	—	A20702-4014	—	2.87	2.57



Sakura Manga Comic Pro Sets

Designed specifically for the professional manga artist. The Set of 8 includes six Black Pigma Micron pens (005, 01, 02, 03, 05, and 08), a Pigma Graphic 1 pen, and a 0.7 mm mechanical pencil. The Set of 6 includes three Black Pigma Micron pens (005, 03, and 08), a Graphic 1 Pen, a brush pen, and a 0.7 mm mechanical pencil.

NUMBER	SET	EACH	6/EA
A20702-1069	Set of 6	\$20.68	\$18.62
A20702-1089	Set of 8	27.40	24.65



A-B Sakura Pigma Micron Sets

Permanent, waterproof, pigmented ink in a fine-point drawing and writing pen. Unlike dye-based ink found in most pens and markers, Pigma ink will not feather or bleed through the thinnest paper. Derived from a single pigment to ensure color consistency, it's also fadeproof when exposed to sunlight or UV light. These pens won't clog or dry out like most mechanical pens. Non-refillable. Black ink.

A Set of 3 Black — Includes 0.25 mm (01), 0.35 mm (03), and 0.45 mm (05).

NUMBER	EACH	6/EA
A20702-2009	\$8.35	\$7.45

Set of 3 Black — Includes 0.5 mm (08), 0.6 mm (10), and 0.7 mm (12).

NUMBER	EACH	6/EA
A20702-1139	\$8.26	\$7.43

B Set of 6 Black — Includes 0.20 mm (005), 0.25 mm (01), 0.30 mm (02), 0.35 mm (03), 0.45 mm (05), and 0.50 mm (08).

NUMBER	EACH	6/EA
A20702-2069	\$16.15	\$14.45

Set of 6 Black — Includes 0.25 mm (01), 0.35 mm (03), 0.45 mm (05), 0.50 mm (08), 0.60 mm (10), and 0.70 mm (12).

NUMBER	EACH	6/EA
A20702-1169	\$16.15	\$14.45

Set of 8 Black — Includes 0.20 mm (005), 0.25 mm (01), 0.30 mm (02), 0.35 mm (03), 0.45 mm (05), 0.50 mm (08), Pigma Brush, and 1.0 mm Pigma Graphic.

NUMBER	EACH	6/EA
A20702-2089	\$23.95	\$21.55

Set of 16 Black — Includes Brush (2); Micron 05 point (3), 01 (2), 08 (2), 005 (1), 02 (1), and 03 (1); and Graphic 1 mm (2), 2 mm (1), and 3 mm (1).

NUMBER	EACH	6/EA
A20702-2105	\$45.55	\$40.99

Set of 10 Black — 0.15 mm (003), 0.20 mm (005), 0.25 mm (01), 0.30 mm (02), 0.35 mm (03), 0.45 mm (05), 0.50 mm (08), 0.60 mm (10), 0.70 mm (12), and one Pigma PN (0.45 mm).

NUMBER	EACH	6/EA
A20702-1109	\$14.50	\$13.05

Set of 16 Black — Includes 0.15 mm (003), 0.20 mm (005), 0.25 mm (01), 0.30 mm (02), 0.35 mm (03), 0.45 mm (05), 0.50 mm (08), 0.60 mm (10), 0.70 mm (12) one each Pigma Graphic in sizes 1 mm, 2 mm, 3 mm, two pigma PN (0.45 mm) Pens, and two Pigma Brush Pens.

NUMBER	EACH	6/EA
A20702-2169	\$45.55	\$40.99

Set of 16 Colors — Includes 16 Micron 05 point pens in Black (2), Blue, Red, Green, Brown, Purple, Yellow, Orange, Rose, Sepia, Royal Blue, Burgundy, Hunter Green, Blue/Black, and Fresh Green.

NUMBER	EACH	6/EA
A20702-1005	\$45.55	\$40.99

Set of 6, 0.25 mm Assorted Colors — Includes Black, Red, Blue, Green, Brown, and Purple.

NUMBER	EACH	6/EA
A20702-9000	\$16.15	\$14.45

Set of 6, 0.45 mm Assorted Colors — Includes Black, Red, Blue, Green, Brown, and Purple.

NUMBER	EACH	6/EA
A20702-0069	\$16.15	\$14.45

Set of 4, Size 003 and 005 Assorted — Includes one each of Size 003 Black and Sepia; and one each of Size 005 Black and Sepia.

NUMBER	EACH	6/EA
A20702-0359	\$12.05	\$10.85

Set of 6, Size 03 Assorted — Includes two each of Black, and one each of Blue, Green, Red, and Sepia.

NUMBER	EACH	6/EA
A20702-0369	\$16.15	\$14.45

Set of 6, 0.20 mm Assorted Colors — Includes Black, Red, Blue, Green, Brown, and Purple.

NUMBER	EACH	6/EA
A20702-0169	\$16.15	\$14.45

Set of 4 Sepia — Includes 0.25 mm (01), 0.45 mm (05), Brush (2), and 1 mm (2).

NUMBER	EACH	6/EA
A20702-8089	\$12.05	\$10.85

Sakura Pigma Professional Brush Pens

These pens offer the ultimate in versatility. Their durable brush nibs were specially developed to provide fantastic bounce and memory over long periods of use. They respond to instant changes in pressure or direction with a silky smooth, accurate, consistent ink flow. The deep black, archival Pigma ink won't smear, feather, or bleed through most papers. Those who prefer brushes will appreciate the flexibility of a portable brush with continuous ink flow, avoiding the need to dip the brush and carry messy inks.

NUMBER	DESCRIPTION	EACH	12/EA
A24537-2020	Fine Brush	\$4.54	\$4.08
A24537-2021	Medium Brush	4.54	4.08
A24537-2022	Bold Brush	4.54	4.08
A24537-1003	Set of 3 Black	14.18	12.77



C Pentel Arts Hybrid Technica Pen

Smooth, pigmented ink is delivered through a long-lasting tungsten carbide roller tip delivery system, guaranteeing a consistent line from the first drop of ink to the last. Acid-free and archival for sketching, drawing, manga art, and more. The pen will not dry out if uncapped during use.

NUMBER	SIZE	EACH	12/EA
A21014-2003	0.3 mm	\$3.36	\$2.99
A21014-2004	0.4 mm	3.36	2.99
A21014-2005	0.5 mm	3.36	2.99
A21014-2006	0.6 mm	3.36	2.99
A21014-2028	0.8 mm	3.36	2.99

Set of 5 — Includes 0.3 mm, 0.4 mm, 0.5 mm, 0.6 mm, and 0.8 mm.

NUMBER	EACH	12/EA
A21014-2029	\$15.22	\$13.69



D STAEDTLER Pigment Liners

Great for writing, sketching, and drawing, with a long metal tip that works well with rulers and templates. The Pigment Liner's indelible black pigment ink is waterproof and extremely lightfast, yet erasable when used on drafting paper.

The ink won't bleed when highlighted. Leave the cap off for up to 18 hours without dryout. A durable barrel guarantees long life, and automatic pressure equalization prevents pens from leaking during air travel.

NUMBER	DESCRIPTION	EACH	12/EA
A21829-1005	0.05 mm	\$4.80	\$4.32
A21829-2001	0.1 mm	4.80	4.32
A21829-2003	0.3 mm	4.80	4.32
A21829-2005	0.5 mm	4.80	4.32
A21829-2007	0.7 mm	4.80	4.32
A21829-2021	1 mm	4.80	4.32
A21829-2012	1.2 mm	4.80	4.32
A21829-2022	2 mm Calligraphy	4.80	4.32
A20757-9000	4 Assorted	17.54	15.79
A20757-1009	6 Assorted	33.03	29.73
A20757-2029	8 Black	35.10	31.59



Rotring Isograph Technical Pen College Sets

A classic pen with a modern design and the smooth writing action of a fine fountain pen. Rotring nibs are crafted from the finest stainless steel, and hand-finished for a smooth, precise inking edge. Each pen includes five black ink cartridges.

NUMBER	DESCRIPTION	EACH	3/EA
A22274-1001	0.2 mm, 0.3 mm, 0.5 mm	\$107.28	\$96.56
A22274-1002	0.25 mm, 0.35 mm, 0.5 mm	107.28	96.56
A22274-1003	0.2 mm, 0.4 mm, 0.6 mm	107.28	96.56

Rapidograph H.R.S. Set

Humidified Revolving Selector prevents ink from drying in pen points. Set includes three pen holders, a bottle of ink, a bottle of pen cleaner, a board clamp, nib keys, and a cap for each point. Sizes 3x0, 2x0, 0, 1, 2, 3, and 4.

NUMBER	EACH	3/EA
A21005-2209	\$234.46	\$210.99



E Pentel Arts Sign Pen

Ideal for artists — or anyone who enjoys drawing and sketching — this pen features a sturdy fiber tip and permanent, acid-free black pigment ink that is water-resistant and fadeproof. A secure, snap-fit cap prevents marker dryout. Part of the Recycology™ line of products; made of 80% recycled plastic.

NUMBER	DESCRIPTION	COLOR	EACH	12/EA
A22505-2020	Single Pen	Black	\$4.19	\$3.76
A22585-1012	Set of 12	Assorted	36.92	33.23

Koh-I-Noor RapidoSketch™ Set

This versatile pen handles like a pencil, moving in all directions without snagging or digging into the drawing surface. It's the most affordable professional-grade drawing pen on the market. Use it to draw precise lines with an engraver's perfection, for a loose sketching style or a finely detailed pointillist technique. Set includes the RapidoSketch pen with stainless steel nib and refillable ink system, 3/4 oz bottle of Rapidograph Ultradraw black India ink in a rigid plastic case. Your choice of 0.25 mm, 0.35 mm, or 0.50 mm nib.

NUMBER	SIZE	EACH	6/EA
A21013-1025	0.25 mm	\$26.35	\$23.72
A21013-1035	0.35 mm	26.35	23.72
A21013-1050	0.50 mm	26.35	23.72



F Koh-I-Noor Rapidograph Pens

Rapidograph pens offer the handling ease of pencil while laying down dense, even-flowing ink lines of controlled, predetermined widths. Air-tight, double-seal cap keeps the point from drying out. Refillable ink reservoir.

NUMBER	SIZE	POINT	EACH	10/EA
A21003-2041	0.18 mm	4x0	\$40.42	\$36.38
A21003-2031	0.25 mm	3x0	37.40	33.66
A21003-2003	0.30 mm	2x0	37.40	33.66
A21003-2002	0.35 mm	0	37.40	33.66
A21003-2010	0.50 mm	1	37.40	33.66
A21003-2020	0.60 mm	2	37.40	33.66
A21003-2025	0.70 mm	2.5	37.40	33.66
A21003-2030	0.80 mm	3	37.40	33.66
A21003-2040	1.20 mm	4	37.40	33.66



Koh-I-Noor Rapidograph Replacement Point Sections

NUMBER	SIZE	POINT	EACH	12/EA
A21003-1041	0.18 mm	4x0	\$29.59	\$26.63
A21003-1031	0.25 mm	3x0	24.24	21.82
A21003-0000	0.30 mm	2x0	24.24	21.82
A21003-1000	0.35 mm	0	24.24	21.82
A21003-1001	0.50 mm	1	24.24	21.82
A21003-1002	0.60 mm	2	24.24	21.82
A21003-1025	0.70 mm	2.5	24.24	21.82
A21003-1003	0.80 mm	3	24.24	21.82
A21003-1004	1.20 mm	4	24.24	21.82



7-Pen Set — Includes sizes 3x0, 2x0, 0, 1, 2, 3, and 4.

NUMBER	EACH	12/EA
A21003-2007	\$167.35	\$150.60

HEALTH & SAFETY ICONS: ●=CL / ■=Prop 65 / ▼=CL & Prop 65
See page 644 for more information.

WARNING! Products marked with a Prop 65 symbol (■ or ▼) can expose you to chemicals, including cadmium, which are known to the State of California to cause cancer and birth defects or other reproductive harm. For more information, visit P65Warnings.ca.gov.

PRISMACOLOR®



PrismaColor® Premier Illustration Markers

All feature archival, acid-free premium pigmented ink to prevent works from deteriorating over time; lightfast colors maintain their vibrancy. For crisp detail work, for artistic and technical applications. Lightfast, permanent, non-toxic, water-resistant. For more information, visit DickBlick.com.

Fine Line Tip

NUMBER	COLOR	SIZE	EACH	12/EA
A22141-2020	Black	0.05 mm	\$3.35	\$2.99
A22141-2021	Black	0.1 mm	3.35	2.99
A22141-2023	Black	0.3 mm	3.35	2.99
A22141-2025	Black	0.5 mm	3.35	2.99
A22141-2028	Black	0.8 mm	3.35	2.99
A22141-5010	Blue	0.05 mm	3.35	2.99
A22141-8000	Brown	0.05 mm	3.35	2.99
A22141-7010	Green	0.05 mm	3.35	2.99
A22141-6000	Purple	0.05 mm	3.35	2.99
A22141-8080	Sepia	0.05 mm	3.35	2.99



Fine Line Sets — 4-Ct Primary: 05 nib in Black, Red, Blue, Green; 5-Ct Black: 005, 01, 03, 05, 08 nibs; 8-Ct Fine: 05 in all eight colors; 8-Ct Extra Fine: 005 nib in eight colors.

NUMBER	SET	EACH	6/EA
A22141-2029	5 Black	\$13.61	\$12.25
A22141-1059	8 Fine	22.27	20.03

Assorted Sets

NUMBER	SET	EACH	6/EA
A22150-8009	4 Black, chisel, brush, fine	\$13.40	\$12.06
A22150-9009	7 Black, chisel, brush, fine	22.31	20.09
A22175-1008	8 Manga	24.03	21.62

Brush Tip

NUMBER	COLOR	EACH	6/EA
A22150-2020	Black	\$3.35	\$2.99
A22150-5010	Blue	3.35	2.99
A22150-7010	Green	3.35	2.99
A22150-6010	Purple	3.35	2.99
A22150-3010	Red	3.35	2.99
A22150-8080	Sepia	3.35	2.99



Pentel Arts® Pocket Brush Pen with Refills

The Pentel Pocket Brush is ideal for creating fine to broad lines with a single brushstroke. Portable and refillable with permanent pigment ink, it's perfect for painting, cartooning, detailing, and much more.

NUMBER	DESCRIPTION	EACH	6/EA
A21894-1001	Pen with 2 Refills	\$20.92	\$18.83
A21894-1002	Refill 2-Pack	3.76	3.38



Copic® Gasenfude Brush Tip Pen

This high-quality brush pen has 9 mm long nylon bristles that mimic a sumi-e brush. The thickness of the mark depends on the pen's angle, the quickness of the stroke, and paper texture. Ideal for hand lettering, calligraphy, comic art, dry-brush effects, and traditional brush art. Archival waterbased pigment ink is compatible with Copic markers.

NUMBER	EACH	6/EA
A21021-2020	\$7.71	\$6.94

Faber-Castell® Pitt® White Big Artist Pen

Filled with odorless, opaque white India ink that is waterproof, bleedproof, permanent, and archival, this pen is great for large format artwork. The durable bullet-shaped nib creates broad, medium, or narrow strokes.

NUMBER	EACH	12/EA
A19917-1020	\$5.93	\$5.34

Winsor & Newton™ FineLiner Pens

A black fineliner that fits every sketching style, these pens feature a smooth, tapered nib and a longer barrel that sits comfortably in the hand and allows for grip adjustments as needed. Use them for sketching, drawing, and writing. The water-resistant, fadeproof pigment ink formula provides a consistent and reliable flow of ink for all kinds of projects.

NUMBER	SIZE	EACH	10/EA
A21061-2021	0.1 mm	\$2.36	\$2.13
A21061-2023	0.3 mm	2.36	2.13
A21061-2035	0.5 mm	2.36	2.13
A21061-2028	0.8 mm	2.36	2.13
A21061-2031	1 mm	2.36	2.13

Set of 5 — Includes 0.1 mm, 0.3 mm, 0.5 mm, 0.8 mm, and 1 mm widths.

NUMBER	EACH
A21061-2025	\$13.34



Faber-Castell® Ecco Pigment Pen

Suitable for writing, drawing, and sketching, the Ecco Pigment Pen is filled with a pigmented black ink for both drawing papers and transparent paper. Waterproof, lightfast ink flows from long, metal-clad fiber tips that work well with rulers and stencils. Ergonomic grip zone; metal clip. The set includes one each of 0.05, 0.1, 0.2, 0.3, 0.4, 0.5, 0.6, and 0.7.

NUMBER	DESCRIPTION	EACH	10/EA
A22589-2021	0.1 mm	\$3.39	\$3.05
A22589-2023	0.3 mm	3.39	3.05
A22589-2025	0.5 mm	3.39	3.05
A22589-2027	0.7 mm	3.39	3.05

NUMBER	EACH
A22589-1009	\$24.49

Tombow® Fudenosuke Brush Pens

Create extra-fine, fine, or medium strokes by just a change in brush pressure. Fudenosuke Brush Pens are great for calligraphy and drawing, and contain waterbased, pigmented ink that is odorless. Pens in 10-pack have hard nibs. Two-pack includes one hard nib pen and one soft nib pen. Barrels are made of recycled polypropylene. Non-refillable.

NUMBER	COLOR	EACH	6/EA
A21044-2022	Black	\$3.78	\$3.41
A21044-5012	Blue	3.78	3.41
A21044-8002	Brown	3.78	3.41
A21044-2502	Gray	3.78	3.41
A21044-7012	Green	3.78	3.41
A21044-4512	Orange	3.78	3.41
A21044-3062	Pink	3.78	3.41
A21044-6002	Purple	3.78	3.41
A21044-3012	Red	3.78	3.41

NUMBER	SET	EACH	6/EA
A21044-1001	2-Pack	\$6.35	\$5.72
A21044-1010	10-Pack	26.43	23.79

Soft Brush Pen

Artist Pen

Brush Pen

Faber-Castell® Pitt® Artist Brush Pens

Pitt Artist Pens with brush nibs are great for sketching, cartooning, and more. They're filled with waterproof, lightfast ink that is acid-free and pH-neutral. Available in 60 versatile colors.

NUMBER	COLOR	EACH	10/EA
A20759-2023	Black	\$3.47	\$3.09
A20759-4203	Cadmium Yellow	3.47	3.09
A20759-6653	Caput Motuum	3.47	3.09
A20759-4153	Chromium Yellow	3.47	3.09
A20759-8353	Cinnamon	3.47	3.09
A20759-5180	Cobalt Blue	3.47	3.09
A20759-7163	Cobalt Green	3.47	3.09
A20759-5473	Cobalt Turquoise	3.47	3.09
A20759-5373	Cobalt Turquoise Lt	3.47	3.09
A20759-2810	Cold Gray I	3.47	3.09
A20759-2833	Cold Gray III	3.47	3.09
A20759-2843	Cold Gray IV	3.47	3.09
A20759-2853	Cold Gray VI	3.47	3.09
A20759-3163	Crimson	3.47	3.09
A20759-4940	Dark Cadmium Yellow	3.47	3.09
A20759-3380	Deep Scarlet Red	3.47	3.09
A20759-7920	Earth Green	3.47	3.09
A20759-7213	Green Gold	3.47	3.09
A20759-7073	Green Olive	3.47	3.09
A20759-5560	Ice Blue	3.47	3.09
A20759-3253	Indian Red	3.47	3.09
A20759-5343	Indianthrene Blue	3.47	3.09
A20759-5210	Indigo Dark	3.47	3.09
A20759-1043	Ivory	3.47	3.09
A20759-7153	Leaf Green	3.47	3.09
A20759-7013	Light Green	3.47	3.09
A20759-5200	Light Indigo	3.47	3.09
A20759-3813	Light Flesh	3.47	3.09
A20759-3860	Light Skin	3.47	3.09
A20759-4913	Light Yellow Glaze	3.47	3.09
A20759-6030	Lilac	3.47	3.09
A20759-3043	Magenta	3.47	3.09
A20759-7333	May Green	3.47	3.09
A20759-3823	Medium Flesh	3.47	3.09
A20759-3861	Medium Skin	3.47	3.09
A20759-6093	Middle Purple Pink	3.47	3.09
A20759-1190	Nougat	3.47	3.09
A20759-4513	Orange Glaze	3.47	3.09
A20759-7293	Oxide Green Fiery	3.47	3.09
A20759-3720	Pale Geranium Lake	3.47	3.09
A20759-5163	Phthalo Blue	3.47	3.09
A20759-7800	Phthalo Green	3.47	3.09
A20759-7803	Phthalo Green Dark	3.47	3.09
A20759-7913	Phthalo Green Light	3.47	3.09
A20759-3063	Pink Carmine	3.47	3.09
A20759-3173	Pink Madder Lake	3.47	3.09
A20759-6063	Purple Violet	3.47	3.09
A20759-8053	Raw Umber	3.47	3.09
A20759-8523	Sanguine	3.47	3.09
A20759-3083	Scarlett Red	3.47	3.09
A20759-8083	Sepia	3.47	3.09
A20759-5913	Sky Blue	3.47	3.09
A20759-3763	Terracotta	3.47	3.09
A20759-5233	Ultramarine	3.47	3.09
A20759-8913	Walnut Brown	3.47	3.09
A20759-2290	Warm Gray I	3.47	3.09
A20759-2303	Warm Gray III	3.47	3.09
A20759-2313	Warm Gray IV	3.47	3.09
A20759-2323	Warm Gray VI	3.47	3.09
A20759-1001	White	3.47	3.09

Faber-Castell® Pitt® Artist Brush Pen Gift Box Sets

Graphic artists, illustrators, designers, architects, and art students will appreciate these sets. Pitt Artist Pens feature lightfast, waterproof India ink and a high-quality brush point — ideal for sketching, fine ink drawings, journals, cartooning, scrapbooking, and rubber stamping. The faux leather gift box doubles as a pen stand.

NUMBER	SET	EACH	5/EA
A20759-4129	12 Assorted	\$36.69	\$32.99
A20759-1249	24 Assorted	84.80	76.31
A20759-1009	48 Assorted	139.68	125.71
A20759-1609	60 Assorted	171.74	154.56

FABER-CASTELL®



Faber-Castell® Pitt® Artist Pens

Pigmented India ink brings great versatility to pen-and-ink drawings that require lots of intricate details. The ink is unsurpassably lightfast, waterproof, acid-free, and pH-neutral.

NUMBER	COLOR	STYLE	EACH	10/EA
A20759-2010	Black	Bullet	\$3.47	\$3.09
A20759-2025	Black	Extra Fine	3.47	3.09
A20759-2021	Black	Fine	3.47	3.09
A20759-2022	Black	Medium	3.47	3.09
A20759-2012	Black	Soft Chisel	3.47	3.09
A20759-2020	Black	Superfine	3.47	3.09
A20759-5010	Blue Metallic	Bullet	4.21	3.80
A20759-7160	Cobalt Green	Superfine	3.47	3.09
A20759-9510	Copper Metallic	Bullet	4.21	3.80
A20759-7010	Green Metallic	Bullet	4.21	3.80
A20759-3381	Dp Scarlet Red	Superfine	3.47	3.09
A20759-9010	Gold Metallic	Bullet	4.21	3.80
A20759-5340	Indianthrene Blue	Superfine	3.47	3.09
A20759-3040	Magenta	Superfine	3.47	3.09
A20759-7330	May Green	Superfine	3.47	3.09
A20759-6090	Mid Purple Pink	Superfine	3.47	3.09
A20759-4510	Orange Glaze	Superfine	3.47	3.09
A20759-5160	Phthalo Blue	Superfine	3.47	3.09
A20759-3370	Ruby Metallic	Bullet	4.21	3.80
A20759-8521	Sanguine	Fine	3.47	3.09
A20759-8522	Sanguine	Medium	3.47	3.09
A20759-8520	Sanguine	Superfine	3.47	3.09
A20759-8081	Sepia	Fine	3.47	3.09
A20759-8082	Sepia	Medium	3.47	3.09
A20759-8080	Sepia	Superfine	3.47	3.09
A20759-9330	Silver Metallic	Bullet	4.21	3.80
A20759-1003	White	Chisel	3.47	3.09
A20759-1002	White	Bullet	3.47	3.09

Sets of 4 — Superfine, Fine, Medium, and Brush.

NUMBER	COLOR	EACH	5/EA
A20759-2024	Black	\$11.06	\$9.96
A20759-8524	Sanguine	11.06	9.96
A20759-8084	Sepia	11.06	9.96

Set of 4 Black — Extra Fine, Superfine, Fine, and Medium.

NUMBER	EACH	5/EA
A20759-2029	\$11.06	\$9.96

Set of 4 Black Illustration — Brush, Bullet, Soft Brush, and Soft Chisel.

NUMBER	EACH	5/EA
A20759-2019	\$11.06	\$9.96

Set of 8 Black — One each Extra Superfine, Superfine, Fine, Medium, Brush, and three new nib varieties — Extrasoft Brush, Round-point Needle, and Wedge.

NUMBER	EACH	5/EA
A20759-0089	\$21.68	\$19.51





A Pilot® Better Ballpoint Pens

Reliable, smooth-writing ballpoint pen with ridged finger grip. Permanent ballpoint ink. Box of 12. Colors can be assorted for quantity pricing.

NUMBER	COLOR	POINT	EACH	12/EA	24/EA
A20717-2001	Black	Fine	\$17.96	\$16.15	\$15.34
A20717-5001	Blue	Fine	17.96	16.15	15.34
A20717-3001	Red	Fine	17.96	16.15	15.34
A20717-2009	Black	Medium	17.96	16.15	15.34
A20717-5009	Blue	Medium	17.96	16.15	15.34

B Pilot® G-TEC-C4 Rolling Ball Gel Pen Set

Enjoy smear-proof, non-feathering writing with these 0.4 mm rolling ball gel pens. Set of 10 includes Black, Blue, Brown, Green, Navy, Orange, Pink, Purple, Red, and Turquoise.

NUMBER	EACH	12/EA	24/EA
A22503-1010	\$24.20	\$21.78	\$20.69

C Pilot® Precise® V5/V7 Retractable Pens

America's No. 1-selling rolling ball pen is now available in a retractable model. The V5 (Extra Fine Point) and V7 (Fine Point) feature Pilot's patented Precise Needle Point technology, a comfortable rubber grip with traction pockets, and super-smooth, airplane-safe liquid ink. Refillable. Colors can be assorted for quantity pricing.

NUMBER	COLOR	POINT	EACH	12/EA	24/EA
A21893-2025	Black	Extra Fine	\$3.07	\$2.77	\$2.63
A21893-5015	Blue	Extra Fine	3.07	2.77	2.63
A21893-6005	Purple	Extra Fine	3.07	2.77	2.63
A21893-3015	Red	Extra Fine	3.07	2.77	2.63
A21893-2027	Black	Fine	3.07	2.77	2.63
A21893-5017	Blue	Fine	3.07	2.77	2.63
A21893-6007	Purple	Fine	3.07	2.77	2.63

D Pilot® VBall Liquid Ink Roller

Pilot combines pure liquid ink technology with an advanced ink feed system to assure smooth, skip-free writing and complete use of every drop. Visible ink supply lets you know when you're running low.

Colors can be assorted for quantity pricing.

NUMBER	COLOR	POINT	EACH	12/EA	24/EA
A20712-2101	Black	Extra Fine	\$2.46	\$2.21	\$2.09
A20712-5101	Blue	Extra Fine	2.46	2.21	2.09
A20712-3101	Red	Extra Fine	2.46	2.21	2.09
A20712-2001	Black	Fine	2.46	2.21	2.09
A20712-5001	Blue	Fine	2.46	2.21	2.09
A20712-3001	Red	Fine	2.46	2.21	2.09

E Pilot® Precise V5/XF 7-Color Set

Unique water- and fade-resistant liquid ink formula maintains consistent strokes from the first word to the last. Advanced ink feed system for smooth, skip-free writing. Features patented extra-fine, 0.5 mm needle-point. Visible ink supply lets you see how much ink is left. Seven-color set in plastic pouch includes one each Blue, Black, Red, Green, Purple, Pink, and Turquoise.

NUMBER	EACH	12/EA	24/EA
A20716-1079	\$16.99	\$15.32	\$14.55

F Pilot® G2® Gel Pens

Water-resistant, smear-proof gel ink offers smooth, skip-free writing. Contoured rubber grip conforms to your fingers for maximum comfort. Refillable and retractable. Choose fine, extra fine, ultra fine, or bold point.

NUMBER	COLOR	POINT	EACH	12/EA
A21821-2022	Black	Ultra Fine	\$2.09	\$1.91
A21821-5012	Blue	Ultra Fine	2.09	1.91
A21821-3012	Red	Ultra Fine	2.09	1.91
A21821-2020	Black	Extra Fine	2.09	1.91
A21821-5010	Blue	Extra Fine	2.09	1.91
A21821-7010	Green	Extra Fine	2.09	1.91
A21821-6000	Purple	Extra Fine	2.09	1.91
A21821-3010	Red	Extra Fine	2.09	1.91
A21821-2021	Black	Fine	2.09	1.91
A21821-5011	Blue	Fine	2.09	1.91
A21821-3141	Burgundy	Fine	2.09	1.91
A21821-7011	Green	Fine	2.09	1.91
A21821-7231	Lime	Fine	2.09	1.91
A21821-5041	Navy	Fine	2.09	1.91
A21821-4511	Orange	Fine	2.09	1.91
A21821-3061	Pink	Fine	2.09	1.91
A21821-6001	Purple	Fine	2.09	1.91
A21821-3011	Red	Fine	2.09	1.91
A21821-5111	Turquoise	Fine	2.09	1.91
A21821-2023	Black	Bold	2.09	1.91
A21821-5013	Blue	Bold	2.09	1.91
A21821-3013	Red	Bold	2.09	1.91

4-Color Fine Point Set

NUMBER	SET	EACH
A21821-2002	Assorted Colors 2	\$9.51

8-Color Fine Point Set

NUMBER	EACH
A21821-1089	\$18.95

8-Color Bold Point Set

NUMBER	EACH
A21821-1008	\$18.95

20-Color Fine Point Set

NUMBER	EACH
A21821-1009	\$41.19

G Pilot® FriXion Erasable Retractable Gel Pens

Press the clip to reveal the nib! A retractable version of this popular erasable gel pen. Use the friction ball tip to erase; even multiple erasures won't damage your documents. Colors can be assorted for quantity pricing.

NUMBER	COLOR	SIZE	EACH	12/EA
A21878-2024	Black	0.5 mm	\$3.14	\$2.82
A21878-5014	Blue	0.5 mm	3.14	2.82
A21878-3014	Red	0.5 mm	3.14	2.82
A21878-2023	Black	0.7 mm	3.14	2.82
A21878-5013	Blue	0.7 mm	3.14	2.82
A21878-3013	Red	0.7 mm	3.14	2.82

Sets

NUMBER	SIZE	SET	EACH	12/EA
A21878-1047	0.5 mm	7 Assorted	\$20.37	\$18.32
A21878-1037	0.7 mm	7 Assorted	20.37	18.32

H Uni-Ball® Vision Pens

Uni-flow ink system guarantees smooth, scratch-free writing. The Vision features a stainless steel, 0.7 mm fine point and an ink level window. Colors can be assorted for quantity pricing.

NUMBER	COLOR	EACH	12/EA	24/EA
A20738-2020	Black	\$2.89	\$2.58	\$2.46
A20738-5000	Blue	2.89	2.58	2.46

I Paper Mate® InkJoy® Retractable Gel Pen Sets

The revolutionary InkJoy writing system means effortless, non-smearing writing! These colorful pens have a rubberized grip that extends the pen length, and a see-through window that shows how much ink is left.

NUMBER	DESCRIPTION	SIZE	EACH	6/EA
A22588-2021	4 Black	0.7 mm	\$10.26	\$9.23
A22588-2022	4 Black	0.5 mm	10.26	9.23
A22588-2020	4 Black, 1.0 mm	10.26	9.23	
A22588-1001	6 Fashion Student Colors	0.7 mm	14.78	13.31
A22588-1003	14 Fashion Colors	0.7 mm	32.38	29.14
A22588-2002	22 Colors	0.7 mm	45.96	41.37

J Pentel® Slicci® Pens

Create designer flourishes and swirls, embellish stamped images, or personalize paper, cards, labels, tags, and die-cuts with these extra-fine (0.25 mm), metal-tipped gel roller pens from Pentel. Choose from eight designer colors, affordably priced for the professional, crafter, or student.

Colors can be assorted for quantity pricing.

NUMBER	COLOR	EACH	12/EA	24/EA
A21887-5350	Baby Blue	\$3.48	\$3.13	\$2.98
A21887-2020	Black	3.48	3.13	2.98
A21887-5010	Blue	3.48	3.13	2.98
A21887-7010	Green	3.48	3.13	2.98
A21887-3060	Pink	3.48	3.13	2.98
A21887-6000	Purple	3.48	3.13	2.98

Set of 8 — 0.8 mm

NUMBER	EACH	12/EA
A21887-1008	\$25.35	\$22.81

K Pentel® RSVP® Colors™ Pen Set

Eight brilliant colors to color-code and organize your notes. The latex-free Comfort Zone grip offers writing comfort. Durable stainless steel tip with a medium point. Black, Red, Blue, Green, Orange, Pink, Sky Blue, and Violet.

NUMBER	EACH	6/EA	12/EA
A21875-1008	\$9.60	\$8.64	\$8.21

L BIC® Atlantis® Bold Retractable Ball Pens

Experience a bold, vivid writing with Bic Atlantis Bold Retractable Ball Pens. Available in a variety of fun fashion colors, they feature a smooth-click retractable point, ink that is smoother than Bic's classic ink system, a comfortable rubber grip, and a metal clip. For set contents, visit DickBlick.com.

NUMBER	SET	POINT	EACH	12/EA
A21031-1053	3 Fashion	0.7 mm	\$4.97	\$4.48
A21031-1033	3 Fashion	1.2 mm	4.97	4.48
A21031-1003	3 Fashion	1.6 mm	4.97	4.48



M Pentel® Pop Gel Pen Sets

Add a pop of color with Pentel Milky Pop and Sparkle Pop Pen sets. These vivid gel inks show up especially well on dark papers. The pens have medium points (0.8 mm) and extra-long, balanced barrels for effortless writing and control. For set colors, visit DickBlick.com.

NUMBER	DESCRIPTION	EACH	6/EA
A00866-1008	0.8 mm, Milky Pop	\$20.45	\$18.41
A00865-1009	1.0 mm, Sparkle Pop	20.45	18.41



N Sakura® Gelly Roll Moonlight™ Pens

Gelly Roll Moonlight works like a paint pen on colored papers, vellum, and photographs. The creamy, smooth, opaque ink is perfect for writing in journals, decorating cards, pattern drawing, or making detailed accents. The fluorescent colors glow under a black light. Archival colors contain pigment-based ink that is chemically stable, waterproof, and fade-resistant. Fluorescent colors may fade if exposed to direct sunlight. 0.5 mm bold line. Colors can be assorted for quantity pricing.

NUMBER	COLOR	EACH	12/EA
A22577-5010	Blue	\$1.61	\$1.44
A22577-7270	Fluorescent Green	1.61	1.44
A22577-4560	Fluorescent Orange	1.61	1.44
A22577-3480	Fluorescent Pink	1.61	1.44
A22577-3000	Fluorescent Vermilion	1.61	1.44
A22577-4220	Fluorescent Yellow	1.61	1.44
A22577-7010	Green	1.61	1.44
A22577-6000	Purple	1.61	1.44
A22577-3010	Red	1.61	1.44
A22577-3170	Rose	1.61	1.44

NUMBER	SET	EACH	12/EA
A22577-1009	5 Color, Dawn	\$7.71	\$6.94
A22577-1019	5 Color, Dusk	7.71	6.94
A22577-1029	10 Color	13.69	12.32



O Sakura® Gelly Roll® Stardust™ Pens

A constellation of 12 glittering colors that sparkle. Ideal for greeting cards, memos, invitations, and more. A creamy, smooth 0.5 mm bold line won't bleed through on vellum and most papers. Archival-quality ink. Colors can be assorted for quantity pricing.

NUMBER	COLOR	EACH	12/EA	24/EA
A20758-5000	Blue	\$1.97	\$1.78	\$1.69
A20758-9500	Copper	1.97	1.78	1.69
A20758-9000	Golden	1.97	1.78	1.69
A20758-7000	Green	1.97	1.78	1.69
A20758-7230	Lime	1.97	1.78	1.69
A20758-5230	Marine	1.97	1.78	1.69
A20758-3060	Pink	1.97	1.78	1.69
A20758-6000	Purple	1.97	1.78	1.69
A20758-3000	Red	1.97	1.78	1.69
A20758-3170	Rose	1.97	1.78	1.69
A20758-9330	Silver	1.97	1.78	1.69
A20758-5070	Sky	1.97	1.78	1.69

Stardust Clear — Roller pen creates sparkle wherever you want it without a heat gun or messy powders. 0.5 mm line. Package of 2.

NUMBER	EACH	12/EA	24/EA
A20758-1029	\$3.98	\$3.58	\$3.40



Sakura® Gelly Roll® Pen Sets

Packs of five.

NUMBER	DESCRIPTION	EACH	12/EA
A20747-0059	Hot Metallic, 0.4 mm	\$7.95	\$7.16
A20747-1059	Dark Metallic, 0.4 mm	7.95	7.16
A20747-1159	Dark, 0.3 mm	7.95	7.16
A20777-1029	3 White	4.93	4.44

Set of 10 Metallic Gelly Roll Pens — Two Metallic Gold pens and one each of the other Metallic colors listed above. Medium point.

NUMBER	EACH	12/EA
A20713-1010	\$14.22	\$12.79



Box Set of 74 — Every color in the Gelly Roll line, including the Classic, Moonlight, Stardust, Metallic, Gold Shadow, and Silver Shadow lines, plus White and Stardust Clear.

NUMBER	EACH	12/EA
A20747-1749	\$116.92	\$105.20

P Sakura® Gelly Roll® Pens

Gelly Roll, the original gel ink rollerball, has a consistent 0.3 mm point. For those seeking a bolder line, the 0.4 mm line width is perfect to ensure fax transmittal, carbon copy transfer, and emphasizing your messages. Ultra-smooth, waterproof, and chemical-resistant, the ink is permanent when dry. Colors can be assorted for quantity pricing.

Fine — 0.3 mm

NUMBER	COLOR	EACH	12/EA	24/EA
A20713-2001	Black	\$1.58	\$1.42	\$

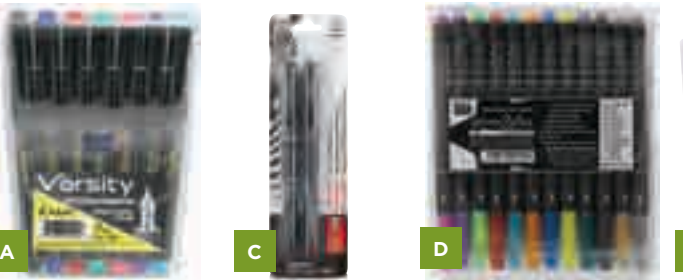

A Pilot® Varsity® Pens

Pilot's Varsity fountain pen combines contemporary design and modern convenience with the smooth writing of a liquid ink fountain pen. The Varsity is lightweight and disposable without the messy cartridge changes that classic fountain pens are known for. Use it for everyday writing, lettering, and calligraphy. The ink supply window on the barrel lets you see how much ink is left.

NUMBER	COLOR	EACH	12/EA
A21853-2020	Black	\$3.71	\$3.34
A21853-5010	Blue	3.71	3.34
A21853-3060	Pink	3.71	3.34
A21853-6000	Purple	3.71	3.34
A21853-5110	Turquoise	3.71	3.34
A21853-1079	7 Colors	26.69	24.03

B Copic® Drawing Pens

The Drawing Pen is a disposable fountain pen with a stainless steel tip. It offers the feel and varying line width of a traditional fountain pen without the need to refill — no mess! Its bleedproof, pigment-based ink is great for sketchbooks or travel journals. Choose Black or Sepia — for an "Old World" feel.

NUMBER	DESCRIPTION	EACH	12/EA
A21896-2021	Black 1 mm	\$6.52	\$5.87
A21896-8081	Sepia 1 mm	6.52	5.87
A21896-2022	Black 2 mm	6.52	5.87

C Zebra® Zensations™ Fountain Pen Set

Designed for artists and writers alike, these fine point fountain pens offer smooth writing, great control, and vibrant colors. Thanks to an innovative, efficient ink system, every drop of the free-flowing ink is utilized, and there are no cartridges to refill. Every pen has a stainless steel nib and a fine, 0.6 mm point.

NUMBER	SIZE	EACH	6/EA
A04855-2029	2 Black	\$6.59	\$5.93

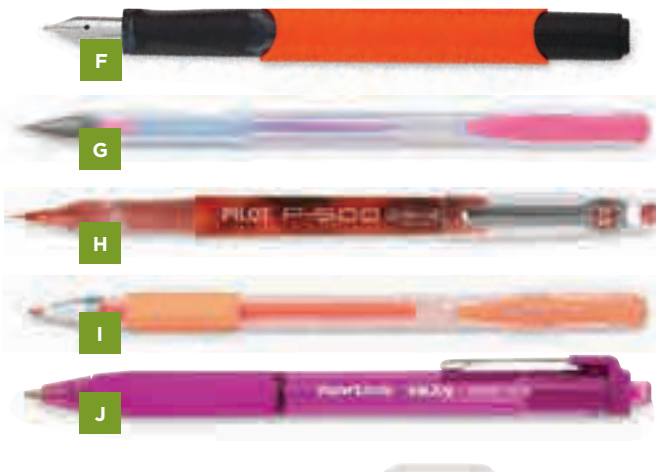

D Copic® Spica Glitter Pen Sets

Micro-glass flakes give Spica Glitter Pens maximum sparkle! The no-clog tip assures smooth writing and great sparkle distribution — plus, they offer twice the writing length of comparable glitter pens (360 yards). Waterbased, transparent pigment ink is acid-free, archival, and non-toxic. For set contents, visit DickBlick.com.

NUMBER	SET	EACH	12/EA
A21898-1169	6-Color Set 1	\$19.20	\$17.28
A21898-1269	6-Color Set 2	19.20	17.28
A21898-1001	12-Color Set A	39.56	35.61
A21898-2001	12-Color Set B	39.56	35.61

E BIC® Soft Feel® Retractable Ball Point Pen Sets

The Bic Soft Feel Ball Point Pen has a soft, comfortable barrel for writing comfort, a no-slip grip for all-day use, and a 1.0 mm medium point. Convenient retractable click action. For set colors, visit DickBlick.com.

NUMBER	SET	EACH	12/EA
A21032-1001	5 Fashion Colors	\$5.50	\$4.95
A21032-1002	12 Fashion Colors	14.03	12.62

F Manuscript® Curve Fountain Pens

Combining style and substance, the Manuscript Curve Fountain Pen is the perfect handwriting instrument. The Blue, Green, and Orange pens have iridium nibs. The White pen comes with three iridium nibs — a medium nib for defined handwriting, a 2B nib for line variation, and a high-quality handwriting nib. All four pens include one blue ink cartridge.

NUMBER	COLOR	EACH	6/EA
A21046-5010	Blue	\$11.54	\$10.39
A21046-7010	Green	11.54	10.39
A21046-4510	Orange	11.54	10.39
A21046-1020	White	16.99	15.30

G Fiskars® Gel Pen Classroom Set

Bring your craft projects to life with vivid color! This set offers a full spectrum of distinctive colors that include neon, glitter, metallic, and even two colors swirled together. The free-flowing, acid-free ink can be used on both light and dark paper. A total of 48 pens, in tip sizes from 0.8–1.0 mm. For set contents, visit DickBlick.com.

NUMBER	EACH	6/EA
A22528-1048	\$21.83	\$19.64

H Pilot® P-500/P-700 Gel Rollers

Pilot's patented precise needle point technology and dynamic gel ink formula assure a smooth, smear-proof writing experience. The distinctive two-tone barrel features a ribbed grip for comfort and control.

NUMBER	COLOR	EACH	12/EA
A22508-2025	Black 0.5 mm	\$2.54	\$2.29
A22508-5015	Blue 0.5 mm	2.54	2.29
A22508-3015	Red 0.5 mm	2.54	2.29
A22508-2027	Black 0.7 mm	2.54	2.29
A22508-5017	Blue 0.7 mm	2.54	2.29
A22508-7017	Green 0.7 mm	2.54	2.29
A22508-3017	Red 0.7 mm	2.54	2.29

I Sargent Art® Gel Pen Sets

Bring sparkle and shine to all your creations with Sargent Art Gel Pens. Choose sets of 10 glitter, fluorescent, or metallic colors. The set of 100 also includes a wide variety of brilliant colors. All come in convenient reclosable pouches.

NUMBER	DESCRIPTION	EACH	12/EA
A00847-1401	100 Assorted	\$38.36	\$34.53
A00847-1101	Set of 10	6.29	5.66
A00847-1201	Set of 10	6.29	5.66
A00847-1301	Set of 10	6.29	5.66

J Paper Mate® Inkjoy® Ballpoint Pen Sets

A combination of ultra low-viscosity ink and an optimized tip allow for crisp, clean lines with no dragging and minimal hand pressure. These colorful, retractable ballpoint pens have an extended rubberized grip and a handy metal clip. The ink color matches the barrel color. 1.0 mm medium point.

NUMBER	SET	EACH	12/EA
A21017-1008	8 Fashion Colors	\$5.28	\$4.75
A21017-1024	24 Fashion Colors	14.45	12.99

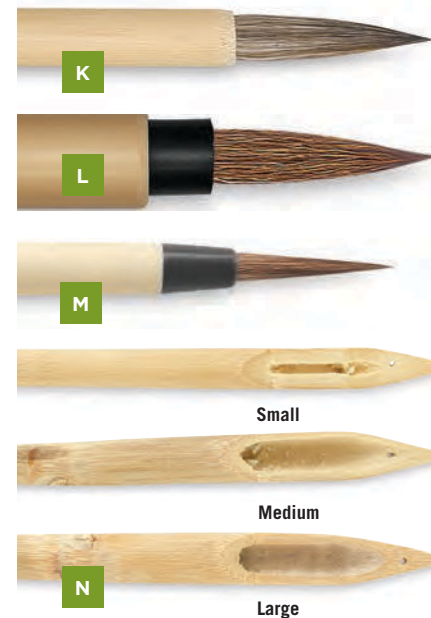

K Blick® Brown Hair Sumi Brush

This pointed-hair brush is great for Japanese calligraphic writing or painting. It is handmade with a bamboo handle and dyed goat hair.

NUMBER	SIZE	DIA	LENGTH	EACH	12/EA
A05401-1001	1	1/4"	1-1/16"	\$5.65	\$5.09
A05401-1002	2	5/16"	1-1/8"	6.63	5.97
A05401-1006	6	3/8"	1-7/8"	11.22	10.10

3-Brush Set — Sizes: 1, 2, and 6.

NUMBER	EACH	12/EA
A05410-9003	\$10.95	\$9.85

L Blick® Bamboo Brushes

A long, tapered point of soft, dyed goat hair for watercolors, ink, and Japanese calligraphic lettering and sumi-e painting. Hand-set in a plastic ferrule with a bamboo handle.

NUMBER	SIZE	DIA	LENGTH	EACH	12/EA
A05409-1002	2	7/32"	1-1/16"	\$3.63	\$3.27
A05409-1004	4	5/16"	1-1/4"	4.92	4.43
A05409-1006	6	7/16"	1-3/4"	6.43	5.79

3-Brush Set — Sizes: 2, 4, and 6.

NUMBER	EACH	6/EA
A05412-9003	\$7.92	\$7.13

M Yasutomo® Bamboo Brushes

Selected fine-quality hair is combined to form this excellent all-purpose brush. Because of its sharp tip and firm body, it performs various strokes well while still being flexible enough for shading and coloring. Also recommended for watercolor.

NUMBER	SIZE	DIA	LENGTH	EACH	12/EA
A05414-1000	0	3/32"	3/4"	\$8.88	\$7.99
A05414-1002	2	5/32"	15/16"	10.89	9.80
A05414-1004	4	1/4"	1-1/4"	15.51	13.95
A05414-1006	6	3/8"	1-11/16"	22.93	20.63

N Richeson® Bamboo Reed Pens

Create a classic look with these pens made from hard, strong, hand-carved bamboo. Ideal for black line drawing and calligraphy with liquid sumi ink. The small pen measures 6-1/2" long, the medium pen measures 6-3/4" long, and the large pen measures 9-5/8" long.

NUMBER	DESCRIPTION	EACH	6/EA
A04898-1001	Small	\$3.11	\$2.80
A04898-1002	Medium	3.43	3.08
A04898-1003	Large	3.97	3.57



O Yasutomo® Sketch Paper Pads

Designed for use by professionals and students alike, these sketch pads offer an unbeatable combination of quality and economy. Strong and absorbent, the papers are made in the centuries-old Japanese tradition from the fibers of the mulberry tree. Because they do not shrink or tear easily, they are good for woodblock or lino printing, as well as for scrapbooking, cards, and invitations. Acid-free. For use with pencil, crayon, charcoal, and pen-and-ink.

NUMBER	DESCRIPTION	EACH	12/EA
A12236-1023	9" x 12", 48 Sheets	\$14.69	\$13.22
A12952-1006	12-1/8" x 18-1/8", 50 Sheets	19.74	17.77

P Yasutomo® Japanese Rice Paper

Fine Hanshi rice paper for brush writing or calligraphy is mold-made in the centuries-old Japanese tradition. Provides excellent quality at an affordable price for beginners as well as professionals. 9-1/2" x 13" sheets.

NUMBER	DESCRIPTION	EACH	12/EA
A12744-1013	100-Sheet Pad	\$13.25	\$11.92
A12744-5013	500-Sheet Ream	60.93	54.83

Q Sumi Painting Paper

Acid-free, not sized. Oriental white rice paper for sumi painting, calligraphy, sketching, and more. 50-sheet, 12-1/8" x 18-1/8" pad.

NUMBER	DESCRIPTION	EACH	12/EA
A12952-1006	12-1/8" x 18-1/8", 50 Sheets	\$19.74	\$17.77
A12952-1022	Kozo, 11" x 60 ft	19.99	17.99



R Yasutomo® Liquid Sumi Ink

Sumi ink in convenient liquid form. This permanent black ink is made from quality vegetable oil soot for sumi painting and calligraphy.

NUMBER	COLOR	SIZE	EACH	6/EA
A20827-2004	Black	2 oz (60 ml)	\$6.57	\$5.95
A20827-2006	Black	12 oz (355 ml)	18.76	16.99
A20827-2060	Black	60 oz (1.78 liter)	73.35	66.43

Metallic Black — These are very dense black inks with metallic powder suspended in them. They work best on rice papers, creating a black outline that surrounds the Gold or Silver powder.

NUMBER	COLOR	SIZE	EACH	6/EA
A21159-2750	Metallic Golden Black	180 ml	\$10.03	\$9.11
A21159-2130	Metallic Silver Black	180 ml	10.03	9.11

S Yasutomo® Waterproof Liquid Sumi Ink

Permanent, black ink in a liquid form, made from quality vegetable oil soot and formulated especially for sumi painting and calligraphy. Contains shellac.

NUMBER	SIZE	EACH	12/EA
A21135-1002	2 oz (60 ml)	\$6.06	\$5.46
A21135-1012	12 oz (355 ml)	15.69	14.12



The Art and Technique of Sumi-e

Explore the ancient art of Japanese ink painting. This wonderful resource contains extensive explanations of sumi-e techniques as well as detailed painting instructions and diagrams. Kay Morrissey Thompson. Hardcover. 72 pages. 10-1/2" x 10".

NUMBER	EACH
A67322-1001	\$16.48



T Yasutomo® Sumi Ink Sticks

These ink sticks are unsurpassed for producing the famous Five Colors, or shades of black, that form the basis of "monochromatic" sumi painting. The subtlety of sumi ink is evident in the variety of tones and values it produces. Use professional-quality sticks to create darker tones, and artist-quality sticks to produce a range of grays.

NUMBER	DESCRIPTION	EACH	12/EA
A20828-1001	Artist-Quality	\$7.50	\$6.77
A20828-1002	Professional-Quality	15.78	14.20

U Yasutomo® Suzuri Grinding Stone

A manmade inkstone with a well to hold water and a flat surface on which to grind the sumi stick. After use, clean thoroughly with water because dried sumi on the grinding surface will later interfere with making sumi ink.

NUMBER	EACH	12/EA
A20829-0000	\$14.99	\$13.51



A Sakura® Pigma Brush

Specifically developed to meet the needs of calligraphers and free-hand artists who require a fine point, flexible, brush-style nib. The ink is quick-drying, waterproof, fade-resistant, archival, and will not smear when dry. The Pigma Brush is capable of drawing very fine

lines or broad strokes simply by changing the pressure applied to the nib. Colors can be assorted for quantity pricing.

NUMBER	COLOR	EACH	12/EA
A21308-2001	Black	\$3.20	\$2.89
A21308-5001	Blue	3.20	2.89
A21308-8001	Brown	3.20	2.89
A21308-7001	Green	3.20	2.89
A21308-4501	Orange	3.20	2.89
A21308-6001	Purple	3.20	2.89
A21308-3001	Red	3.20	2.89
A21308-3171	Rose	3.20	2.89
A21308-8080	Sepia	3.20	2.89

Set of 6 Brush Markers — Black, Red, Green, Blue, Brown, and Purple.

NUMBER	EACH	12/EA
A21308-0069	\$17.24	\$15.52

B Sakura® Pen-Touch™ Calligrapher Metallic Ink Calligraphy Pens

A calligraphy pen with a flat nib that allows you to produce beautiful lettering with very little practice. The opaque ink dries quickly on paper, and is permanent on most surfaces, including plastic, wood, glass, and metal. The fine point makes a 1.8 mm line with a nib made from a special plastic that won't split or fray. The medium point produces a 5.0 mm line with a fiber nib cut into a rectangular block. Xylene-free and low odor.

NUMBER	COLOR	POINT	EACH	12/EA
A20817-2020	Black	Fine	\$4.18	\$3.76
A20817-9500	Copper	Fine	4.18	3.76
A20817-4051	Gold	Fine	4.18	3.76
A20817-9300	Silver	Fine	4.18	3.76
A20817-2021	Black	Medium	4.18	3.76
A20817-9501	Copper	Medium	4.18	3.76
A20817-4052	Gold	Medium	4.18	3.76
A20817-9310	Silver	Medium	4.18	3.76

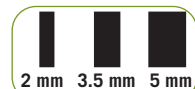

C Yasutomo® Calligraphy Marker Set

These pens have unique mini-chiseled tips for true calligraphic control. The dense, non-toxic, non-waterproof ink flows generously. Sold in a set of three, one each 2 mm, 3.5 mm, and 5 mm.

NUMBER	COLOR	EACH	6/EA
A20832-2009	Black	\$6.04	\$5.44

D Itoya® Doubleheader Calligraphy Marker

The Doubleheader provides performance and vibrant color for any lettering project. Two chisel points offer thick or thin lines: a 3.0 mm wide point for bold, distinctive lines, and a 1.5 mm narrow point for smaller, more intricate designs. Ink is acid-free and archival. Colors can be assorted for quantity pricing.

NUMBER	COLOR	EACH	6/EA
A20820-5360	Aquamarine	\$2.37	\$2.14
A20820-2003	Black	2.37	2.14
A20820-5003	Blue	2.37	2.14
A20820-2980	Cabernet	2.37	2.14
A20820-9170	Dijon	2.37	2.14
A20820-7220	Evergreen	2.37	2.14
A20820-7003	Green	2.37	2.14
A20820-8370	Mocha	2.37	2.14
A20820-3053	Pink	2.37	2.14
A20820-6003	Purple	2.37	2.14
A20820-3003	Red	2.37	2.14

E Zig® Calligraphy Pen

Explore the art of italic and gothic calligraphy! Excellent for personalizing greeting cards, invitations, certificates, journal entries, artwork — or just practicing your technique — these pens contain odorless, xylene-free black ink for creating crisp strokes and flourishes.

NUMBER	DESCRIPTION	EACH	10/EA
A04878-1001	3 Oblique Tip Pens	\$7.34	\$6.60
A04878-1002	3 Square Tip Pens	7.34	6.60

F Faber-Castell® Pitt® Calligraphy Pens

These versatile calligraphy pens contain the same ink as the immensely popular Pitt Artist Pens. Each contains highly pigmented India ink that is acid-free, archival (pH-neutral), smudgeproof, water-resistant, and fade-resistant. With a 2 mm chisel-edged nib, they work wonderfully for any calligraphy project, including greeting cards, scrapbooking, journaling, and other paper crafts.

NUMBER	COLOR	EACH	3/EA
A20870-2020	Black	\$3.18	\$2.90

Set of 3

NUMBER	COLOR	EACH	5/EA
A20870-2029	Black	\$12.68	\$11.41

Set of 3

NUMBER	COLOR	EACH	5/EA
A20870-1009	Assorted	\$12.68	\$11.41

Set of 6

NUMBER	COLOR	EACH	5/EA
A20870-1019	Assorted	\$14.84	\$13.36
A20870-1029	Subtle Colors	14.84	13.36

Manuscript® CalliCreative Duotip Markers

These sets of double-ended markers in a variety of gorgeous colors are great for lettering, coloring, doodling, and crafting. Use them for creating long-lasting decorations, or for embellishing greeting cards, scrapbooks, and journals. Ideally used on paper, these versatile markers have two tips, a 3 mm angled italic chisel nib and a fineline nib.

NUMBER	SET	EACH	10/EA
A04846-1010	10 Assorted	\$11.18	\$10.07
A04846-1020	20 Assorted	20.52	18.47



Zig® Calligraphy II Twin Tip Pens

Designed specifically for scrapbooks, memory books, photo albums, journals, diaries, wedding invitations, stationery, certificates, greeting cards, and crafts. Two tips — one broad (3.5 mm) to title pages and make simple borders, and narrow (2.0 mm) for delicate lettering and scrollwork. Pure pigment ink stands the test of time, so your precious memories can be preserved for future generations. The ink is photo-safe, acid-free, lightfast, fadeproof, non-bleeding, odorless, xylene free, and smear-proof (when dry).

NUMBER	SET	EACH	6/EA
A20992-1069	6 Assorted	\$17.99	\$16.18
A20992-1129	12 Assorted	35.96	32.36



Speedball® Elegant Writer Calligraphy Markers

Create beautiful invitations, holiday cards, gift tags, and more with Elegant Writers. The crisp chisel nibs and free-flowing, acid-free ink make it easy to form lovely calligraphic letters. For set colors, visit DickBlick.com.

NUMBER	COLOR	SIZE	EACH	12/EA
A20861-2010	Black	Fine	\$1.84	\$1.66
A20861-2020	Black	Medium	1.84	1.66
A20861-2030	Black	Broad	1.84	1.66
A20861-9010	Gold	Broad	1.93	1.74
A20861-9330	Silver	Broad	1.93	1.74

NUMBER	SIZE	SET	EACH	6/EA
A20860-1009	Assorted	4 Black	\$10.25	\$9.23
A20861-0049	Assorted	4 Special Occasion	8.19	7.38
A20861-1069	Medium	6 Assorted Colors	12.39	11.15
A20861-1209	Medium	12 Assorted	18.13	16.32



Parchment Pad

Bienfang® Calligraphic Parchment and Practice Pads

Made from recycled paper. Ideal for certificates, diplomas, and personalized greeting cards. Excellent surface for pen-and-ink or brushed-on colors.

NUMBER	DESCRIPTION	EACH	12/EA
A12937-8539	Parchment Pad	\$14.09	\$12.67
A12939-1103	Practice Pad	12.35	11.15

Shaeffer® Viewpoint® Calligraphy Pen Sets

Shaeffer's next generation of calligraphy pens feature brightly colored barrels and updated cap and clip designs, while preserving and improving on the features calligraphy artists have enjoyed for years. Ideal for both beginning and experienced calligraphers, these sets bring sophistication and elegance to cards, invitations, journals, scrapbooks, and much more. The color-coded nibs indicate stroke width (Fine, Medium, or Broad), and the barrels have a window that shows the ink color and level. One-year warranty. The Mini Kit has one pen, three nibs, and four ink cartridges. The Maxi Kit has three pens, three nibs, and 20 ink cartridges. For more details, visit DickBlick.com.

NUMBER	DESCRIPTION	EACH	3/EA
A00857-1001	Mini Kit	\$17.99	\$16.22
A00857-1002	Maxi Kit	39.15	35.30



Bee Paper® Aquabee Calligraphy Practice Pads

A thin, non-gridded parchment for calligraphy practice. Includes two formal italic guide sheets. 50-sheet pad.

NUMBER	SIZE	EACH	6/EA
A12939-1005	11" x 14"	\$13.25	\$11.95



Manuscript Calligraphy Sets and Refills

Full instructions and an ink converter are included with these sets of precision-cut, interchangeable nibs that are great for both beginning artists and experienced calligraphers. For set contents, visit DickBlick.com.

NUMBER	DESCRIPTION	EACH	6/EA
A20883-1009	Classic Set	\$20.58	\$18.52
A20883-2009	Deluxe Set	25.69	23.12
A20883-1019	Masterclass Set	24.20	21.78

NUMBER	DESCRIPTION	EACH	6/EA
A20883-1012	12 Black	\$4.36	\$3.92
A20883-1030	30 Assorted Colors	6.06	5.45



12-Pack Refill

Pilot® Parallel Pens

A major breakthrough in calligraphy pen design. The "Parallel Structure" nib consists of two parallel plates, allowing much sharper lines than other calligraphy pens. It can also create graduated colors by transferring ink from one pen nib to another. Pens come with one Black and one Red ink cartridge.

NUMBER	SIZE	EACH	6/EA	12/EA
A20881-2021	1.5 mm	\$10.99	\$9.91	\$9.42
A20881-2022	2.4 mm	10.99	9.91	9.42
A20881-2023	3.8 mm	10.99	9.91	9.42
A20881-2025	6.0 mm	10.99	9.91	9.42
A20881-2013	3.0 mm	10.99	9.91	9.42
A20881-2024	4.5 mm	10.99	9.91	9.42

6-Pack Refills

NUMBER	COLOR	EACH	12/EA
A20881-2026	Black	\$2.19	\$1.98
A20881-5016	Blue/Black	2.19	1.98
A20881-7016	Green	2.19	1.98
A20881-3066	Pink	2.19	1.98
A20881-6006	Purple	2.19	1.98
A20881-3016	Red	2.19	1.98
A20881-5112	Turquoise	2.19	1.98

12-Pack Refills — Contains one each of Black, Blue/Black, Sepia, Violet, Blue, Turquoise, Green, Light Green, Yellow, Orange, Red, and Pink.

NUMBER	EACH	12/EA
A20881-1012	\$4.30	\$3.87

Hand Lettering Calligraphy Set — contains 4 Parallel pens (1.5 mm, 2.4 mm, 3.8 mm, and 6.0 mm), 18 ink cartridges (6 black and 12 assorted colors), a pipette, a nib cleaner and an instruction manual.

NUMBER	EACH	3/EA
A20881-1009	\$47.99	\$43.21



Koh-I-Noor® Pen Cleaner

Perhaps the most effective device ever made for cleaning Koh-I-Noor drawing points. Uses only squeeze pressure. Frequent use keeps points in good condition.

NUMBER	SET	EACH	3/EA
A21146-1001	Set 1	\$98.27	\$88.44
A21146-1029	Set 2	98.27	88.44



Speedball® Fine Point Dip Pen Nibs and Holder

These fine point nibs have a smaller, half-round body that fits holder #104. **#104 Holder** — Durable plastic holder is 4-7/8" long and fits fine nibs #100, #103, and #104.

NUMBER	STYLE	EACH	12/EA	24/EA
A20901-1149	#104 Holder	\$1.69	\$1.52	\$1.44

#100 Artist Nib — Very delicate line for experts.

NUMBER	STYLE	EACH	12/EA	24/EA
A20913-0100	#100 Nib	\$1.43	\$1.29	\$1.22

#103 Mapping — For fine line work and mapping.

NUMBER	STYLE	EACH	12/EA	24/EA
A20913-2030	#103 Nib	\$1.43	\$1.29	\$1.22

#104 Extra Fine Litho Point — Superfine art pen for fine hairlines and detail.

NUMBER	STYLE	EACH	12/EA	24/EA
A20913-1040	#104 Nib	\$1.43	\$1.29	\$1.22



Speedball® Crow Quill Dip Pen Nibs and Holder

Crow quill pens have a cylindrical body that only fits a crow quill holder and generally draws finer lines than standard pens.

#102 Holder — Durable plastic holder is 4-7/8" long and fits crow quill nibs #102, #107, and #108.

NUMBER	STYLE	EACH	12/EA	24/EA
A20901-1049	#102 Holder	\$1.69	\$1.52	\$1.44

#102 Crow Quill Nib — Superfine, flexible.

NUMBER	STYLE	EACH	12/EA	24/EA
A20913-1020	#102 Nib	\$1.43	\$1.29	\$1.22

#107 Stiff Hawk Crow Quill Nib — Superfine, stiffer than #102, for long, even lines, cross-hatching.

NUMBER	STYLE	EACH	12/EA	24/EA
A20913-1070	#107 Nib	\$1.43	\$1.29	\$1.22

#108 Litho Crow Quill Nib — Flexible, bronze finish, for cross-hatching, flourishes.

NUMBER	STYLE	EACH	12/EA	24/EA
A20913-1080	#108 Nib	\$1.43	\$1.29	\$1.22



Speedball® No. 20 General Purpose Set

An eight-piece assortment for delicate fine line, cross-hatching, and lithography. Includes #100, #102, #103, #104, #107, and #108 pen nibs, plus #102 and #104 pen holders.

NUMBER	EACH	12/EA
A20911-1009	\$10.76	\$9.68



Zig® Manga Nib Holder

One holder fits many nibs! Zig's Manga Nib Holder was designed to fit every style in its manga nib series. The tapered wood holder is 5-1/2" long and features a cushioned grip. For nib sets, visit DickBlick.com

NUMBER	EACH	12/EA	24/EA
A20922-1001	\$8.35	\$7.50	\$7.14



Gift Set StarterSet

290 drawing 800.447.8192 to order



Speedball® Standard Pen Holder

6-1/2" long, black plastic holder fits all standard pen points, scratch knives, and lino cutters. (Nib not included. Not for quills or fine point nibs.)

NUMBER	EACH	12/EA	24/EA
A20914-1065	\$1.94	\$1.75	\$1.66



Scratch Art® Standard Pen Holder

5-1/4" long, red plastic holder. Fits all standard pen points, scratch knives, and lino cutters. (Not for quills or fine point nibs.) Package of 12 holders.

NUMBER	EACH	12/EA	24/EA
A22930-0000	\$.73	\$.66	\$.63



Speedball® Standard Point Dip Pen Nibs

Standard pen nibs have a larger, half-round body that only fits a standard pen holder (not quill or fine point holders).

#101 Imperial Nib — Flexible, bronze finish, for ornamental work.

NUMBER	STYLE	EACH	12/EA	24/EA
A20913-1010	#101	\$1.43	\$1.29	\$1.22

#22B Standard Extra Fine Nib — Medium stiff, bronze finish, for ornamental work and ruling.

NUMBER	STYLE	EACH	12/EA	24/EA
A20913-1022	#22B	\$1.26	\$1.14	\$1.08

#512 Bowl Pointed Nib — Fine for ruling and lettering.

NUMBER	STYLE	EACH	12/EA	24/EA
A20913-1512	#512	\$1.26	\$1.14	\$1.08

#56 Standard School Nib — Stiff action, bronze finish, fine drawing pen for student use.

NUMBER	STYLE	EACH	12/EA	24/EA
A20913-1056	#56	\$1.26	\$1.14	\$1.08

#513EF Globe Nib — Extra fine bowl, pointed for industrial arts.

NUMBER	STYLE	EACH	12/EA	24/EA
A20913-1513	#513EF	\$1.26	\$1.14	\$1.08

#99 Standard Drawing Nib — Extra fine point, especially for drafting and lithography.

NUMBER	STYLE	EACH	12/EA	24/EA
A20913-1099	#99	\$1.26	\$1.14	\$1.08



Manuscript Nib Sets

Practice Roman round hand, gothic, uncial, oblique, copperplate, and many other writing styles using these specialized nib sets. Each set includes a variety of nibs in a plastic storage box, and a magnet to facilitate picking of the nibs from the box. For individual set contents, visit DickBlick.com.

NUMBER	DESCRIPTION	EACH	6/EA
A20884-1009	Roman Round Hand Set	\$19.32	\$17.39
A20884-2009	Italic Set	23.03	20.73
A20884-3009	Student Set	24.16	21.74

NUMBER	DESCRIPTION	EACH	6/EA
A04857-1001	Gift Set	\$46.59	\$41.93
A04857-1002	Starter Set	18.60	16.74
A04857-1003	Joseph Gillott Art Pen Drawing Set	23.27	20.94
A04857-1004	Italic Set	11.61	10.45
A04857-1005	Selection Set	25.60	23.04

William Mitchell Calligraphy has been designing and manufacturing exceptional pens for almost 200 years. These Calligraphy Sets are ideal for creating the popular writing styles of Italic, Roman Round Hand, and Uncial.

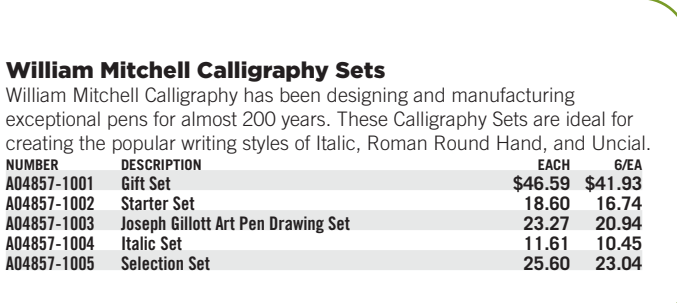

Speedball Super Value Calligraphy & Lettering Kit

A complete beginner's kit: A5, B4, C1, C2 nibs, pen holder, 2 oz (59 ml) each India Ink and pen cleaner, 0.41 oz (12 ml) Metallic Silver ink, practice paper, and instruction booklet.

NUMBER	EACH	12/EA
A20848-2009	\$26.26	\$23.63

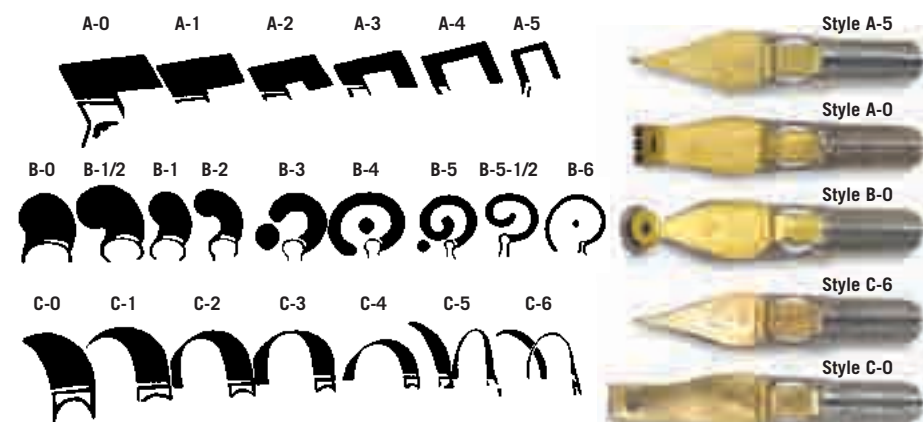

Speedball® Lettering Nibs

Long-lasting, standard dip nibs for all types of lettering with ink and other water media. Choose from three styles and their various widths. Use a standard pen holder (not included). Style A Square — For block and poster gothic letters, ornamental borders, and designs. Style B Round — For Gothic or outline letters, cartoons, uniform line drawing, and posters. Style C Flat — For Roman, text and italic letters, accented lines, scrolls, and scripts.

Individual Right-Hand Nibs — Style C. Use a standard pen holder.

NUMBER	SIZE	STYLE	EACH	12/EA	24/EA
A20909-0003	0	C	\$2.50	\$2.25	\$2.14
A20909-1002	1	C	2.50	2.25	2.14
A20909-1023	2	C	2.50	2.25	2.14
A20909-1033	3	C	2.50	2.25	2.14
A20909-1043	4	C	2.50	2.25	2.14
A20909-1053	5	C	2.50	2.25	2.14
A20909-1063	6	C	2.50	2.25	2.14

Universal Hand Nibs — May be assorted for quantity discount. Choose from Styles A, B, and C shown above. Use a standard pen holder.

NUMBER	SIZE	STYLE	EACH	12/EA	24/EA
A20909-0001	0	A	\$2.50	\$2.25	\$2.14
A20909-1000	1	A	2.50	2.25	2.14
A20909-1021	2	A	2.50	2.25	2.14
A20909-1031	3	A	2.50	2.25	2.14
A20909-1041	4	A	2.50	2.25	2.14
A20909-1051	5	A	2.50	2.25	2.14
A20909-0002	0	B	2.50	2.25	2.14
A20909-0502	1/2	B	2.50	2.25	2.14
A20909-1001	1	B	2.50	2.25	2.14
A20909-1022	2	B	2.50	2.25	2.14
A20909-1032	3	B	2.50	2.25	2.14
A20909-1042	4	B	2.50	2.25	2.14
A20909-1052	5	B	2.50	2.25	2.14
A20909-1055	5-1/2	B	2.50	2.25	2.14
A20909-1062	6	B	2.50	2.25	2.14

Individual Left-Hand Nibs — Special selection of sizes, similar to Style C. Use a standard pen holder.

NUMBER	SIZE	STYLE	EACH	12/EA	24/EA
A20909-0093	0	LC	\$2.50	\$2.25	\$2.14
A20909-1003	1	LC	2.50	2.25	2.14
A20909-1024	2	LC	2.50	2.25	2.14
A20909-1034	3	LC	2.50	2.25	2.14
A20909-1044	4	LC	2.50	2.25	2.14

Set of 5 Left-Hand Pen Nibs — One of each size.

NUMBER	EACH	12/EA	24/EA
A20909-1005	\$14.52	\$13.07	\$12.43



Speedball® No. 5 Artists' Set

Includes six Speedball lettering pen nibs (B-1, B-3, B-5, C-4, C-0, and C-2), pen holder, #56 school dip pen, #102 crow quill, and a crow quill holder.

NUMBER	EACH	12/EA	24/EA
A20905-1005	\$16.20	\$14.58	\$13.86



NEW! The Speedball Textbook 25th Edition

First published in 1915, The Speedball Textbook is a comprehensive resource for artists and letterers of all ages and skill levels. A celebration of the 105th year anniversary of the first edition's debut, this 120-page instructional guide features material from more than 25 artists, with topics including pointed pen, brush and broad-edge calligraphy, sign painting and the history of calligraphy.

NUMBER	EACH
A71101-1025	\$15.99

Speedball® Calligraphy Kit

This introductory calligraphy kit is excellent for beginners. It contains three Style C Speedball Pens (A1, B2, C3), a 2 oz (59 ml) plastic jar of Super Black India Ink, a pen holder, and easy-to-follow instructions.

NUMBER	EACH	12/EA
A20848-1009	\$15.56	\$13.99



Speedball® Acrylic Colored Inks

Rich, vivid colors formulated from the best pigments on earth. This excellent, high-quality ink can be used for a variety of techniques and enables artists, students, and crafters to achieve the best possible results. All colors are intermixable and water-resistant when dry. Set of five palette includes 10 mixing wells and set of 10 includes 13 mixing wells. The set of five includes Black, Gold, Silver, White, and Cleaner.

Individual Right-Hand Nibs — Style C. Use a standard pen holder.

NUMBER	SET	EACH	6/EA
A21124-1059	5 Colors	\$12.24	\$11.03
A21124-1109	10 Colors	24.50	22.05



2 oz (59 ml) Individual Bottles. Colors can be assorted for quantity pricing.

NUMBER	COLOR	EACH	6/EA
A21124-2023	Black	\$5.50	\$4.95
A21124-8053	Burnt Umber	5.50	4.95
A21124-6123	Deep Purple	5.50	4.95
A21124-7053	Emerald Green	5.50	4.95
A21124-9013	Gold	5.50	4.95
A21124-5203	Indigo Blue	5.50	4.95
A21124-3083	Scarlet Red	5.50	4.95
A21124-9333	Silver	5.50	4.95
A21124-7463	Teal Green	5.50	4.95
A21124-1023	White	5.50	4.95
A21124-1003	Pen Cleaner	5.50	4.95



Speedball® Calligraphy Sets

With heritage rooted in fine pen-making since 1899, the Speedball name is synonymous with high-quality lettering pens, nibs, and inks. These sets are wonderful for beginners and collectors alike, specially crafted for this time-honored art form. For set contents, visit DickBlick.com.

NUMBER	SET	EACH	6/EA
A20879-1019	Collector's Wood Box Set	\$59.48	\$53.53
A20879-1029	Complete Calligraphy Set	29.73	26.76

NUMBER	EACH	12/EA
A20879-1019	\$59.48	\$53.53
A20879-1029	29.73	26.76

Fax 800.621.8293 DickBlick.com drawing 291



A Blick® Black Cat Waterproof India Ink

Ours is a dense, black, opaque, pigmented ink that works well in technical pens and airbrushes. Permanent, fadeless, and smearproof. The 1.25 oz (37 ml) size is a glass jar. Other sizes are in plastic bottles.

NUMBER	SIZE	EACH	12/EA	24/EA
A21101-2003	1.25 oz (37 ml)	\$4.51	\$4.05	\$3.85
A21101-2004	3 oz (89 ml)	4.83	4.35	4.13
A21101-2006	Pint (473 ml)	11.12	9.99	9.51
A21101-2007	Quart (946 ml)	18.16	16.34	15.52

B Speedball® Super Black Waterproof India Ink

Made from 100% carbon black pigment. Thus the term "super black," which means its blackness will be very permanent and fadeless. Free-flowing and non-clogging. Plastic, shatter-resistant containers.

NUMBER	SIZE	EACH	12/EA	24/EA
A21104-2004	2 oz (60 ml)	\$5.29	\$4.76	\$4.53
A21104-2006	Pint (473 ml)	11.65	10.49	9.97
A21104-2107	Quart (946 ml)	19.12	17.21	16.36

C Sennelier® India Ink

Intense black, indelible ink has exceptional density and is completely lightfast. Free-flowing, non-clogging, and waterproof. Apply with a brush or dip pen to paper, board, and more for stunning washes or precise lines. The 1 oz (30 ml) size is a glass jar. Other sizes are in glass bottles.

NUMBER	SIZE	EACH	12/EA	24/EA
A21126-1030	1 oz (30 ml)	\$13.27	\$11.95	\$11.35
A21126-0125	4.23 oz (125 ml)	26.22	23.60	22.44
A21126-0500	16.9 oz (500 ml)	65.08	58.58	55.69
A21126-1001	33.8 oz (1 Liter)	122.94	110.70	105.20

D Higgins® Waterproof Black

A bit more economical than Higgins Black Magic. For use with brush, airbrush, and all technical pens. Plastic bottle.

NUMBER	SIZE	EACH	12/EA	24/EA
A21115-2003	1 oz (30 ml)	\$6.11	\$5.50	\$5.22
A21115-2007	Quart (946 ml)	73.48	66.14	62.87

E Higgins® Waterproof Black Magic

Intense, semi-flat black finish on most surfaces. For use with technical pens and airbrushes, dip pens, or brushes. Waterproof, opaque, permanent, fadeless, and acid-free. 1 oz (30 ml) plastic bottle.

NUMBER	EACH	12/EA	24/EA
A21103-2003	\$5.66	\$5.10	\$4.84

F Higgins® Pen Cleaner

Removes dried waterproof ink from pens, lettering instruments, and brushes in an instant. 2-1/2 oz (74 ml) jar.

NUMBER	EACH	12/EA	24/EA
A22933-1004	\$6.91	\$6.23	\$5.91

G Higgins® Waterproof Pigmented Drawing Ink

Vivid, opaque colors are permanent and fadeless. For technical pens, dip pens, brushes, and airbrushes. Colors may be diluted and blended. 1 oz (30 ml) plastic bottle. Colors can be assorted for quantity pricing.

NUMBER	COLOR	EACH	12/EA	24/EA
A21102-5003	Blue	\$5.45	\$4.90	\$4.66
A21102-8003	Brown	5.45	4.90	4.66
A21102-3153	Carmine	5.45	4.90	4.66
A21102-7003	Green	5.45	4.90	4.66
A21102-4063	Lemon	5.45	4.90	4.66
A21102-3043	Magenta	5.45	4.90	4.66
A21102-3003	Red	5.45	4.90	4.66
A21102-6503	Violet	5.45	4.90	4.66
A21102-4003	Yellow	5.45	4.90	4.66

Higgins® Waterproof Drawing Ink Set

The same properties as the Higgins ink (above) in a waterproof formula. Set contains four basic colors: Black, Carmine Red, Indigo, and White. 1 oz (30 ml) plastic bottles.

NUMBER	EACH	12/EA	24/EA
A21102-1049	\$23.44	\$21.10	\$20.05

H Walnut® Drawing Ink

Walnut Ink has a full, warm color that looks great with either a pen or brush and is very lightfast. The Walnut Drawing Stick is two tools in one — a bamboo-tipped nib on one end and a felt pen on the other. Changed from drawing to washing with a twist of the wrist!

NUMBER	DESCRIPTION	EACH	12/EA
A21167-1026	2.4 oz	\$11.57	\$10.41
A21167-1010	8.5 oz	28.65	25.79
A21167-1030	Darkening Medium, 1 oz	11.57	10.41
A22753-1001	Drawing Stick	9.91	8.92

I Dr. Martin's® Bombay™ India Inks

Highly pigmented, powerful color remains lightfast, permanent, and totally waterproof when dry. Adheres to nearly all surfaces. Non-clogging in pens and airbrushes. Colors are transparent; Black and White are opaque and have excellent covering power. 1 oz (30 ml) glass bottle. Colors can be assorted for quantity pricing.

NUMBER	COLOR	EACH	12/EA
A21122-2023	Black	\$5.55	\$4.99
A21122-5003	Blue	5.55	4.99
A21122-3073	Bright Red	5.55	4.99
A21122-8003	Brown	5.55	4.99
A21122-7243	Grass Green	5.55	4.99
A21122-7003	Green	5.55	4.99
A21122-3043	Magenta	5.55	4.99
A21122-3003	Red	5.55	4.99
A21122-5083	Teal	5.55	4.99
A21122-6503	Violet	5.55	4.99
A21122-1013	White	5.55	4.99
A21122-4003	Yellow	5.55	4.99
A21122-1003	Cleaner, 2 oz (60 ml)	4.09	3.68

J Dr. Martin's® Bombay™ India Ink Round Sets

Set 1 — Includes 12, 1 oz (30 ml) dropper bottles of ink in Black, Blue, Bright Red, Brown, Grass Green, Green, Magenta, Red, Teal, Violet, White, and Yellow.

NUMBER	DESCRIPTION	EACH	12/EA
A21122-0129	Set 1 (shown)	\$48.70	\$43.83
A21122-0129	Set 2	\$48.70	\$43.83

Winsor & Newton™ Drawing Inks

Formulated from a series of soluble dyes in a superior shellac solution, these inks can be applied with brush, pen, or airbrush and are widely used by illustrators, designers, calligraphers, and artists. These brilliant colors are fast-drying, water-resistant, fully intermixable, and easily diluted (with distilled water). They feature excellent adhesion on most surfaces. 0.47 oz (14 ml) glass bottles.

Set 1 — Black (India Ink), Blue, Canary Yellow, Emerald, Nut Brown, Orange, Scarlet, and Violet.

NUMBER	EACH	3/EA
A21117-1019	\$41.28	\$37.16

Set 2 — Black (India Ink), Brilliant Green, Deep Red, Peat Brown, Purple, Sunshine Yellow, Ultramarine, and Vermilion.

NUMBER	EACH	3/EA
A21117-1009	\$41.28	\$37.16

For individual Winsor & Newton Drawing Inks, visit DickBlick.com.



Daler-Rowney® FW™ Pearlescent Liquid Acrylic Artists Inks

Lightfast, waterproof inks in shimmering, iridescent colors. Ready to use straight from the bottle with dip pens and brushes. Colors may be intermixed. Colors can be assorted for quantity pricing.

1 oz (30 ml) Glass Dropper Bottle

NUMBER	COLOR	EACH	12/EA
A21111-4593	Autumn Gold	\$6.71	\$6.04
A21111-4913	Bell Bronze	6.71	6.04
A21111-8583	Birdwing Copper	6.71	6.04
A21111-2023	Black	6.71	6.04
A21111-5583	Dutch Blue	6.71	6.04
A21111-5913	Galactic Blue	6.71	6.04
A21111-5193	Genesis Green	6.71	6.04
A21111-4813	Hot Cool Yellow	6.71	6.04
A21111-3713	Hot Mama Red	6.71	6.04
A21111-7913	Macaw Green	6.71	6.04
A21111-4713	Mazuma Gold	6.71	6.04
A21111-6913	Moon Violet	6.71	6.04
A21111-3163	Platinum Pink	6.71	6.04
A21111-2590	Silver Moss	6.71	6.04
A21111-1663	Silver Pearl	6.71	6.04
A21111-5073	Sky Blue	6.71	6.04
A21111-3813	Sundown Magenta	6.71	6.04
A21111-4513	Sun Orange	6.71	6.04
A21111-5393	Sun-Up Blue	6.71	6.04
A21111-3913	Volcano Red	6.71	6.04
A21111-7813	Waterfall Green	6.71	6.04
A21111-1093	White Pearl	6.71	6.04

Pearlescent Effects Set of 6 — Set of six 1 oz bottles, one each Black, Moon Violet, Waterfall Green, Galactic Blue, White Pearl, and Platinum Pink.

NUMBER	EACH	12/EA
A21111-1069	\$42.51	\$38.26

Daler-Rowney® FW Acrylic™ Artists Inks

Pigmented and lightfast, ideal for dip pen, technical pen, brush, and airbrush. Water-resistant and non-clogging. Colors can be assorted for quantity pricing.

1 oz (30 ml) Glass Dropper Bottle

NUMBER	COLOR	EACH	12/EA
A21107-8563	Antelope Brown	\$6.88	\$6.19
A21107-2003	Black	6.88	6.19
A21107-4933	Brilliant Yellow	6.88	6.19
A21107-8053	Burnt Umber	6.88	6.19
A21107-2613	Cool Gray	6.88	6.19
A21107-3163	Crimson	6.88	6.19
A21107-7033	Dark Green	6.88	6.19
A21107-7053	Emerald Green	6.88	6.19
A21107-4613	Flame Orange	6.88	6.19
A21107-3573	Flame Red	6.88	6.19
A21107-4913	Flesh Tint	6.88	6.19
A21107-5241	Fluorescent Blue	6.88	6.19
A21107-7271	Fluorescent Green	6.88	6.19
A21107-4561	Fluorescent Orange	6.88	6.19
A21107-3721	Fluorescent Pink	6.88	6.19
A21107-1001	Fluorescent Red	6.88	6.19
A21107-4221	Fluorescent Yellow	6.88	6.19
A21107-4053	Gold	6.88	6.19
A21107-4163	Indian Yellow	6.88	6.19
A21107-5203	Indigo	6.88	6.19
A21107-4063	Lemon Yellow	6.88	6.19
A21107-7013	Light Green	6.88	6.19
A21107-5553	Marine Blue	6.88	6.19
A21107-7073	Olive Green	6.88	6.19
A21107-2563	Paynes Grey	6.88	6.19
A21107-5513	Process Cyan	6.88	6.19
A21107-3713	Process Magenta	6.88	6.19
A21107-4403	Process Yellow	6.88	6.19
A21107-5223	Prussian Blue	6.88	6.19
A21107-6103	Purple Lake	6.88	6.19
A21107-8063	Raw Sienna	6.88	6.19
A21107-8493	Red Earth	6.88	6.19
A21107-5913	Rowney Blue	6.88	6.19
A21107-7093	Sap Green	6.88	6.19
A21107-3083	Scarlet	6.88	6.19
A21107-8083	Sepia	6.88	6.19
A21107-5213	Shimmering Blue	6.88	6.19
A21107-4093	Shimmering Gold	6.88	6.19
A21107-7023	Shimmering Green	6.88	6.19
A21107-3113	Shimmering Red	6.88	6.19
A21107-5113	Turquoise	6.88	6.19
A21107-6513	Velvet Violet	6.88	6.19
A21107-1003	White	6.88	6.19
A21107-4043	Yellow Ochre	6.88	6.19

Sets — Six each, 1 oz (30 ml) glass bottles.

NUMBER	DESCRIPTION	EACH	12/EA
A21107-1019	Fluorescent Colors	\$38.84	\$34.96
A21107-2009	Primary Colors	38.84	34.96
A21107-3009	Shimmering Colors	38.84	34.96

DANIEL SMITH® Walnut Ink

The warm character of walnut ink is reminiscent of drawings by Rembrandt. This rich, finely pigmented ink has a sepia color that resembles traditional walnut-based inks, but it will not fade. Use Walnut Ink for drawings with both dip pens and brushes.

Because it's waterbased, it handles like a watercolor on washes, with good layering and lifting capabilities. 2 oz (59 ml) bottle.

NUMBER	EACH	12/EA
A02200-1002	\$11.38	\$10.25

Koh-I-Noor® Water-Resistant Drawing Ink

Ideal for use in a Rapidograph or other technical pen, airbrush, or dip pen. Available in Opaque Black and White, plus 17 vivid, intermixable, transparent colors that can be diluted with distilled or oiled water. Drawings made with colored ink should not be exposed to direct sunlight or strong artificial light for long periods of time. Colors can be assorted for quantity pricing.

1 oz (30 ml) Plastic Bottle with Squeeze Top

NUMBER	COLOR	EACH	5/EA
A21108-5393	Blue Violet	\$7.61	\$6.85
A21108-8043	Burnt Sienna	7.61	6.85
A21108-3153	Carmine Red	7.61	6.85
A21108-5183	Cobalt Blue	7.61	6.85
A21108-5593	Cyan Blue	7.61	6.85
A21108-7043	Deep Green	7.61	6.85
A21108-2613	Gray	7.61	6.85
A21108-7013	Light Green	7.61	6.85
A21108-2213	Opaque Black	7.61	6.85
A21108-1073	Opaque White	7.61	6.85
A21108-4503	Orange	7.61	6.85
A21108-5223	Prussian Blue	7.61	6.85
A21108-3763	Red Violet	7.61	6.85
A21108-3083	Scarlet Red	7.61	6.85
A21108-8083	Sepia	7.61	6.85
A21108-8123	Sienna	7.61	6.85
A21108-5233	Ultramarine	7.61	6.85
A21108-3283	Vermilion	7.61	6.85
A21108-4003	Yellow	7.61	6.85

Liquitex® Professional Acrylic Ink™

These extremely fluid colors contain super-fine pigments suspended in a state-of-the-art emulsion. Quick-drying, permanent, water-resistant, and non-clogging, use them for watercolor effects, color-blocking, underpainting, airbrushing, calligraphy, and stamping.

No dilution required. Colors can be assorted for quantity pricing.

1 oz (30 ml) Glass Dropper Bottle

NUMBER	COLOR	EACH	3/EA
--------	-------	------	------

Amsterdam Ink
This highly fluid acrylic ink has very low sedimentation, can be thinned with water or mediums, and dries water-resistant. Spectacular performance with airbrushes, technical pens, fountain pens, brush application, pouring, or applying with the included dropper. The 46-color range includes metallics and reflex colors. All colors match up with Amsterdam Acrylic paints and Amsterdam Acrylic markers, and also work great with Amsterdam Acrylic mediums. 30 ml jars. **Colors can be assorted for quantity pricing.**



NUMBER	COLOR	EACH	6/EA
A02201-4913	Azo Orange	\$6.60	\$5.94
A02201-4923	Azo Yellow Deep	6.60	5.94
A02201-4453	Azo Yellow Lemon	6.60	5.94
A02201-5063	Brilliant Blue	6.60	5.94
A02201-8043	Burnt Sienna	6.60	5.94
A02201-8053	Burnt Umber	6.60	5.94
A02201-3153	Carmine	6.60	5.94
A02201-9163	Deep Gold	6.60	5.94
A02201-7053	Emerald Green	6.60	5.94
A02201-5863	Grey Blue	6.60	5.94
A02201-5923	Kings Blue	6.60	5.94
A02201-9153	Light Gold	6.60	5.94
A02201-3713	Light Rose	6.60	5.94
A02201-3603	Naphthol Red Deep	6.60	5.94
A02201-1023	Naples Yellow Deep	6.60	5.94
A02201-4143	Naples Yellow Red Light	6.60	5.94
A02201-2543	Neutral Grey	6.60	5.94
A02201-7073	Olive Green Deep	6.60	5.94
A02201-7863	Olive Green Light	6.60	5.94
A02201-2223	Oxide Black	6.60	5.94
A02201-7083	Permanent Green Deep	6.60	5.94
A02201-7313	Permanent Green Light	6.60	5.94
A02201-3733	Permanent Red Violet Light	6.60	5.94
A02201-5163	Phthalo Blue	6.60	5.94
A02201-4533	Primary Yellow	6.60	5.94
A02201-5953	Primary Cyan	6.60	5.94
A02201-3043	Primary Magenta	6.60	5.94
A02201-3763	Pyrrrole Red	6.60	5.94
A02201-3273	Quinacridone Rose	6.60	5.94
A02201-3793	Quinacridone Rose Light	6.60	5.94
A02201-8063	Raw Sienna	6.60	5.94
A02201-7013	Reflex Green	6.60	5.94
A02201-4513	Reflex Orange	6.60	5.94
A02201-3173	Reflex Rose	6.60	5.94
A02201-4023	Reflex Yellow	6.60	5.94
A02201-9333	Silver	6.60	5.94
A02201-5073	Sky Blue Light	6.60	5.94
A02201-1023	Titanium White	6.60	5.94
A02201-5113	Turquoise Blue	6.60	5.94
A02201-7913	Turquoise Green	6.60	5.94
A02201-5233	Ultramarine	6.60	5.94
A02201-6733	Ultramarine Violet	6.60	5.94
A02201-3283	Vermillion	6.60	5.94
A02201-2323	Warm Grey	6.60	5.94
A02201-4043	Yellow Ochre	6.60	5.94
A02201-4753	Yellowish Green	6.60	5.94

Daler-Rowney Aquafine Watercolor Inks

These highly saturated, pigment-based watercolor inks are perfect for a wide range of uses and techniques. They can be applied directly using the included dropper, or by using paint markers, technical pens, airbrushes, or brushes like a traditional watercolor. Available in a range of 20 rich colors, these transparent, intermixable inks are lightfast and will not fade over time. 1 oz (30 ml) dropper bottles. **Colors can be assorted for quantity pricing.**



NUMBER	COLOR	EACH	12/EA
A02207-8050	Burnt Umber	\$8.20	\$7.38
A02207-3540	Cadmium Red Hue	8.20	7.38
A02207-4350	Cadmium Yellow Hue	8.20	7.38
A02207-4280	Cadmium Yellow Deep Hue	8.20	7.38
A02207-1050	Chinese White	8.20	7.38
A02207-5190	Cobalt Blue Hue	8.20	7.38
A02207-5170	Coeruleum	8.20	7.38
A02207-9010	Gold	8.20	7.38
A02207-2250	Ivory Black	8.20	7.38
A02207-2020	Lamp Black	8.20	7.38
A02207-7150	Leaf Green	8.20	7.38
A02207-4060	Lemon Yellow	8.20	7.38
A02207-5160	Phthalo Blue	8.20	7.38
A02207-3710	Portrait Pink	8.20	7.38
A02207-3620	Quinacridone Magenta	8.20	7.38
A02207-8060	Raw Sienna	8.20	7.38
A02207-9330	Silver	8.20	7.38
A02207-5340	Ultramarine Dark Blue	8.20	7.38
A02207-3780	Ultramarine Pink	8.20	7.38
A02207-4040	Yellow Ochre	8.20	7.38
NUMBER	DESCRIPTION	EACH	6/EA
A02207-1009	Set of 6 Colors	\$46.65	\$41.98

Ranger Tim Holtz Alcohol Inks and Metallic Mixatives™

These dye-based, acid-free inks can be applied to glossy paper, shrink plastic, glass, and other slick surfaces. Choose from a range of three-color palettes for coloring, journaling, even doodling. Fast-drying and transparent, they can be intermixed — or added to Metallic



Beach Deco

Mixatives to create luminous highlights. Sets include three 0.5 oz (15 ml) bottles with precision tips. **Colors can be assorted for quantity pricing.**

Inks — For set colors, visit DickBlick.com.

NUMBER	DESCRIPTION	EACH	6/EA
A02204-1006	Beach Deco	\$12.63	\$11.36
A02204-1007	Conservatory	12.63	11.36
A02204-1001	Dockside Picnic	12.63	11.36
A02204-1003	Farmer's Market	12.63	11.36
A02204-1012	Key West	12.63	11.36
A02204-1004	Mariner	12.63	11.36
A02204-1005	Retro Cafe	12.63	11.36
A02204-1011	Rodeo	12.63	11.36
A02204-1002	Summit View	12.63	11.36

Metallic Mixatives — Luminous, fast-drying, and acid-free, for creating metallic highlights when combined with Tim Holtz Alcohol Inks. Sets include two 0.5 oz bottles with precision tips.

NUMBER	DESCRIPTION	EACH	6/EA
A02204-1008	Gold/Silver	\$12.63	\$11.36
A02204-1009	Pearl/Copper	12.63	11.36
A02204-1010	Rose Gold/Gunmetal	12.63	11.36

Vallejo Acrylic Artist Inks

Formulated with permanent pigments and acrylic resin, these brilliant, radiantly clear inks can be applied with pens, brushes, rollers, and airbrushes. They dry to a waterproof, satin finish, allowing immediate overpainting and layering of colors. They also can be mixed with each other or with other acrylic colors and acrylic mediums. Mix them with water to create glazes and transparencies, or to tint textures and grounds. Tools clean up with water. Dried ink can be removed with alcohol. 1 oz (30 ml) dropper bottles.



Colors can be assorted for quantity pricing.

NUMBER	COLOR	EACH	6/EA
A02209-2023	Black	\$6.50	\$5.85
A02209-2413	Black Pearl	6.50	5.85
A02209-3153	Carmine Red	6.50	5.85
A02209-8123	Copper	6.50	5.85
A02209-7033	Dark Green	6.50	5.85
A02209-9013	Gold	6.50	5.85
A02209-7013	Green	6.50	5.85
A02209-4163	Indian Yellow	6.50	5.85
A02209-5023	Light Blue	6.50	5.85
A02209-9353	Old Silver	6.50	5.85
A02209-7073	Olive Green	6.50	5.85
A02209-4513	Orange	6.50	5.85
A02209-5093	Process Blue	6.50	5.85
A02209-3043	Process Magenta	6.50	5.85
A02209-4403	Process Yellow	6.50	5.85
A02209-5223	Prussian Blue	6.50	5.85
A02209-8063	Raw Sienna	6.50	5.85
A02209-3013	Red	6.50	5.85
A02209-8083	Sepia	6.50	5.85
A02209-9333	Silver	6.50	5.85
A02209-5113	Turquoise	6.50	5.85
A02209-8533	Umber	6.50	5.85
A02209-6513	Violet	6.50	5.85
A02209-1023	White	6.50	5.85



Marabu Aqua Ink Graphix McFloaty Set

This ultra-brilliant, waterbased watercolor ink is naturally transparent and highly lightfast. Use it with a brush or drawing pen, or combine it with other drawing materials such as Marabu Fineliners and Aqua Pens for expressive motifs and brilliant backgrounds. The McFloaty Set includes six .5 oz (15 ml) bottles (Black, Cyan, Lemon, Magenta, Mint, and Vermilion).

NUMBER	EACH	6/EA
A02205-1001	\$18.29	\$16.46



Ink Pads

NUMBER	COLOR	EACH	6/EA
A21155-8440	Aged Mahogany	\$7.17	\$6.46
A21155-1500	Antique Linen	7.17	6.46
A21155-3730	Barn Door	7.17	6.46
A21155-2090	Black Soot	7.17	6.46
A21155-1190	Broken China	7.17	6.46
A21155-1040	Brushed Corduroy	7.17	6.46
A21155-6460	Bundled Sage	7.17	6.46
A21155-5290	Chipped Sapphire	7.17	6.46
A21155-7070	Crushed Olive	7.17	6.46
A21155-4740	Dried Marigold	7.17	6.46
A21155-6030	Dusty Concord	7.17	6.46
A21155-5910	Faded Jeans	7.17	6.46
A21155-3710	Fired Brick	7.17	6.46
A21155-7520	Forest Moss	7.17	6.46
A21155-8110	Frayed Burlap	7.17	6.46
A21155-6040	Milled Lavender	7.17	6.46
A21155-4230	Mustard Seed	7.17	6.46
A21155-1010	Old Paper	7.17	6.46

Ink Pads

NUMBER	COLOR	EACH	6/EA
A21155-1030	Peeled Paint	\$7.17	\$6.46
A21155-7910	Pine Needles	7.17	6.46
A21155-1310	Pumice Stone	7.17	6.46
A21155-4910	Rusty Hinge	7.17	6.46
A21155-4110	Scattered Straw	7.17	6.46
A21155-1510	Shabby Shutters	7.17	6.46
A21155-4510	Spiced Marmalade	7.17	6.46
A21155-1410	Spun Sugar	7.17	6.46
A21155-2680	Stormy Sky	7.17	6.46
A21155-3170	Tattered Rose	7.17	6.46
A21155-8010	Tea Dye	7.17	6.46
A21155-1610	Tumbled Glass	7.17	6.46
A21155-2730	Victorian Velvet	7.17	6.46
A21155-1020	Vintage Photo	7.17	6.46
A21155-8910	Walnut Stain	7.17	6.46
A21155-8090	Weathered Wood	7.17	6.46
A21155-4410	Wild Honey	7.17	6.46
A21155-3720	Worn Lipstick	7.17	6.46



Ranger Tim Holtz Distress Inks

These acid-free, fade-resistant, waterbased inks are perfect for the vintage, stained, aged effects for scrapbook pages, cards, and altered art projects. Use them on papers, photos, fiber, ribbon, wood, and more to create a weathered look. They're also great for embossing, photo tinting, and layering. The pads feature a raised felt pad for direct-to-paper techniques.



Ranger Archival Ink Pads

Ranger Archival Inks produce lasting results in a classic palette of rich, fade-resistant, water-resistant colors. Archival safe for all your paper projects, these inks provide crisp, stamped images over waterbased dye inks, alcohol inks, acrylic paints, and watercolors. Jet Black is ideal for stamping open images to be colored. For Re-inkers, visit DickBlick.com.

Ink Pads

NUMBER	COLOR	EACH	6/EA
A21154-5360	Aquamarine	\$7.17	\$6.46
A21154-4630	Bright Tangelo	7.17	6.46
A21154-4460	Buttercup	7.17	6.46
A21154-7040	Cactus Flower	7.17	6.46
A21154-3740	Carnation Red	7.17	6.46
A21154-4150	Chrome Yellow	7.17	6.46
A21154-5180	Cobalt	7.17	6.46
A21154-8000	Coffee	7.17	6.46
A21154-6120	Deep Purple	7.17	6.46
A21154-7050	Emerald Green	7.17	6.46
A21154-5270	French Ultram	7.17	6.46
A21154-7030	Garden Patina	7.17	6.46
A21154-2040	Jet Black	7.17	6.46
A21154-7150	Leaf Green	7.17	6.46
A21154-7990	Library Green	7.17	6.46
A21154-3090	Magenta	7.17	6.46
A21154-6500	Majestic Violet	7.17	6.46
A21154-5810	Manganese Blue	7.17	6.46
A21154-4550	Monarch Orange	7.17	6.46
A21154-7070	Olive	7.17	6.46
A21154-5080	Paradise Teal	7.17	6.46
A21154-3520	Pink Peony	7.17	6.46
A21154-6170	Plum	7.17	6.46
A21154-3500	Rose Madder	7.17	6.46
A21154-8080	Sepia	7.17	6.46
A21154-2530	Shadow Grey	7.17	6.46
A21154-5070	Sky Blue	7.17	6.46
A21154-4910	Sunflower	7.17	6.46
A21154-3510	Tea Rose	7.17	6.46
A21154-4160	Tiger Lily	7.17	6.46
A21154-3280	Vermilion	7.17	6.46
A21154-3750	Vibrant Fuchsia	7.17	6.46
A21154-6510	Violet	7.17	6.46
A21154-7890	Viridian	7.17	6.46
A21154-7630	Vivid Chartruese	7.17	6.46
A21154-5370	Watering Can	7.17	6.46



Ranger Tim Holtz Distress Ink Minis

Don't let the small size fool you! These stackable 1" x 1" mini ink pads can be used in the same way as their full-size counterparts. Each kit includes four mini pads that coordinate with the Distress palette of products. For set colors, visit DickBlick.com.

NUMBER	DESCRIPTION	EACH	6/EA
A21168-1001	Kit #1	\$11.39	\$10.28
A21168-1002	Kit #2	11.39	10.28
A21168-1003	Kit #3	11.39	10.28



Ranger Embossing Powders

Enhance your artwork and memory crafting with the elegance of professional embossing powders. Available in a variety of colors and textures, these superfine powders are great for finely detailed stamps. Just pour onto a stamped image, apply heat to melt and set, and pour off the excess. Acid-free and non-toxic. Made in the USA. 1 oz (30 ml) clear jar with see-through lid.

NUMBER	COLOR	EACH	12/EA
A02296-2020	Black	\$5.45	\$4.90
A02296-5010	Blue	5.45	4.90
A02296-1010	Clear	5.45	4.90
A02296-9500	Copper	5.45	4.90
A02296-3710	Cranberry	5.45	4.90
A02296-9010	Gold	5.45	4.90
A02296-2230	Gunmetal	5.45	4.90
A02296-7010	Green	5.45	4.90
A02296-3040	Magenta	5.45	4.90
A02296-4740	Marigold	5.45	4.90
A02296-3060	Pink	5.45	4.90
A02296-6000	Purple	5.45	4.90
A02296-3010	Red	5.45	4.90
A02296-3780	Rose Gold	5.45	4.90
A02296-9330	Silver	5.45	4.90
A02296-2021	Super Fine Black	5.45	4.90
A02296-1011	Super Fine Clear	5.45	4.90
A02296-9501	Super Fine Copper	5.45	4.90
A02296-9011	Super Fine Gold	5.45	4.90
A02296-9331	Super Fine Silver	5.45	4.90
A02296-1021	Super Fine White	5.45	4.90
A02296-1020	White	5.45	4.90

Marabu Alcohol Inks

Create stunning works of art on a variety of surfaces with these vibrant, versatile, dye-based alcohol inks. Marabu Alcohol Ink comes in a wide range of colors (including metallics) that can be used on their own or combined to create an infinite range of colors. Fast-drying, permanent, and acid-free, they can be used on polypropylene and glossy papers, ceramics, metal, shrink plastic, vinyl, leather, glass, and more.

The bottles have a narrow precision tip for easy application — great for ink pouring projects! Use the extender to lengthen working time, lighten and lift colors, and increase transparency.

NUMBER	COLOR	EACH	6/EA
A02216-1010	Extender	\$3.57	\$3.19
A02216-1040	Rainbow Additive	4.46	3.99
A02216-1030	Agave	3.57	3.19
A02216-3710	Amethyst	3.57	3.19
A02216-7170	Apple	3.57	3.19
A02216-7110	Aqua Green	3.57	3.19
A02216-5560	Artic	3.57	3.19
A02216-2020	Black	3.57	3.19
A02216-3720	Bordeaux	3.57	3.19
A02216-8000	Brown	3.57	3.19
A02216-8340	Caramel	3.57	3.19
A02216-5910	Caribbean	3.57	3.19
A02216-3450	Cherry Red	3.57	3.19
A02216-8350	Cinnamon	3.57	3.19
A02216-3730	Garnet Red	3.57	3.19
A02216-1020	Gentian	3.57	3.19
A02216-4060	Lemon	3.57	3.19
A02216-3040	Magenta	3.57	3.19
A02216-9600	Metallic Bronze	4.46	3.99
A02216-8200	Metallic Copper	4.46	3.99
A02216-9010	Metallic Gold	4.46	3.99
A02216-9330	Metallic Silver	4.46	3.99
A02216-7070	Olive Green	3.57	3.19
A02216-6000	Purple	3.57	3.19
A02216-4910	Red Orange	3.57	3.19
A02216-4630	Tangerine	3.57	3.19
A02216-5110	Turquoise	3.57	3.19
A02216-1500	Vanilla	3.57	3.19



Tim Holtz Distress Spray Stain

The same fluid, water-reactive formula crafters have come to love in Tim Holtz Distress Stains is now available in a spray format. Ideal for quick and easy ink coverage on paper and other porous surfaces, these acid-free spray dyes come in a plastic bottle with a high-quality mist sprayer. They're great for spraying through stencils, layering with other colors, and spritzing with water to blend colors and create mottled effects. 2 oz (56 ml) bottle.



NUMBER	COLOR	EACH	12/EA
A02298-1001	Aged Mahogany	\$6.23	\$5.61
A02298-1101	Antique Linen	6.23	5.61
A02298-1201	Antiqued Bronze	6.23	5.61
A02298-1301	Barn Door	6.23	5.61
A02298-2020	Black Soot	6.23	5.61
A02298-1401	Broken China	6.23	5.61
A02298-1501	Brushed Pewter	6.23	5.61
A02298-7070	Crushed Olive	6.23	5.61
A02298-7220	Evergreen Bough	6.23	5.61
A02298-1601	Faded Jeans	6.23	5.61
A02298-3710	Fired Brick	6.23	5.61
A02298-1701	Mowed Lawn	6.23	5.61
A02298-4230	Mustard Seed	6.23	5.61
A02298-5210	Peacock Feathers	6.23	5.61
A02298-1801	Peeled Paint	6.23	5.61
A02298-3360	Picked Raspberry	6.23	5.61
A02298-1901	Picket Fence	6.23	5.61
A02298-2001	Salty Ocean	6.23	5.61
A02298-2101	Seedless Preserves	6.23	5.61
A02298-2201	Spiced Marmalade	6.23	5.61
A02298-2301	Tarnished Brass	6.23	5.61
A02298-3170	Tattered Rose	6.23	5.61
A02298-8910	Walnut Stain	6.23	5.61
A02298-2401	Weathered Wood	6.23	5.61
A02298-2501	Wild Honey	6.23	5.61



Marabu Art Sprays

Add colorful accents to cards, gifts, and paper crafts with Marabu Art Sprays. Ideal for backgrounds, stenciling, and creating mixed media designs on paper, canvas, and wood, these acrylic sprays are intermixable, quick-drying, lightfast, and waterproof when dry. Because they're waterbased, you can thin them with water. 1.7 oz (50 ml) spray bottles.

NUMBER	COLOR	EACH	12/EA
A21170-7170	Apple	\$5.57	\$4.99
A21170-2020	Black	5.57	4.99
A21170-5910	Caribbean	5.57	4.99
A21170-3450	Cherry Red	5.57	4.99
A21170-8360	Cocoa	5.57	4.99
A21170-6500	Gentian	5.57	4.99
A21170-9010	Gold	5.57	4.99
A21170-4060	Lemon	5.57	4.99
A21170-3360	Raspberry	5.57	4.99
A21170-9330	Silver	5.57	4.99

For more colors, visit DickBlick.com.



Ranger Heat It Craft Tool

The quick, easy way to melt embossing powder, this heating tool was specifically designed to be fast, quiet, and convenient. Guaranteed not to burn your projects, it can be used for embossing, shrink-wrapping, or to heat set or dry inks. The tool measures 3-1/2" x 6-1/4" x 2-3/4".

NUMBER	EACH	6/EA
A04838-1001	\$27.80	\$25.03



Ranger Emboss It Ink Pad and Pens

This specially developed embossing ink stays wet for an extended period of time, allowing the perfect amount of time necessary for heat embossing with embossing powders. Clear ink is non-toxic. The pad measures 2-3/4" x 3-7/8". Set of two pens includes one Clear and one Black. For usage details, visit DickBlick.com.

NUMBER	DESCRIPTION	EACH	12/EA
A02297-1001	Pad	\$6.19	\$5.57
A02297-2022	Set of 2 Pens	5.79	5.21



Bic Classroom Packs

Outfit your classroom with these essential supplies. Great for testing environments and art rooms, these Bic favorites in high-count classroom packs offer quality and reliability at a value price.

NUMBER	DESCRIPTION	SET	EACH	6/EA
A22378-4010	Bic Brite Liner Highlighters	Yellow, 200-ct	\$90.92	\$81.83
A22165-2200	Bic Marking Color Collection Permanent Markers	Black, 200-ct	118.62	106.80
A21062-2021	BIC Round Stic Extra Life Pens	Black, 240-ct	34.57	31.10
A21062-1001	BIC Round Stic Extra Life Pens	Assorted, 240-ct	34.57	31.10
A26807-1001	Bic Xtra-Life Mechanical Pencils	320-ct	99.72	89.75



Jolly Booster XL Markers

Jolly Booster XL Markers are great for young artists just learning to draw, with brilliant colors and barrels designed to fit comfortably in their small hands. The markers feature robust, chunky tips that can't be pushed back into the marker barrel, which means hours of coloring fun. Best of all, the marker ink is washable for easy cleanup from hands and clothing. Made in Austria. For children 3+ and older. For set contents, visit DickBlick.com.

NUMBER	DESCRIPTION	EACH	6/EA
A22373-1069	6 Colors	\$7.42	\$6.68
A22373-1149	14 Colors	14.96	13.47
A22373-1449	144 Class Pack	149.39	134.46

Bubble Pool Set — Six each of 14 colors in plastic containers, plus 10 replacement caps and 20 replacement marker tips.

NUMBER	EACH	6/EA
A22373-1849	\$102.10	\$91.89



Crayola Silly Scents Washable Marker Sets

Infused with the sweet smell of creativity, Silly Scents Markers pair bold colors with yummy scents that appeal to kids, such as Fruit Punch, Root Beer, and Cotton Candy. Chisel tips work for detailed drawing and writing, and for laying down large areas of color. Ink washes from skin and most clothing. For set colors, visit DickBlick.com.

NUMBER	DESCRIPTION	EACH	12/EA
A22369-1010	10 Slim	\$5.26	\$4.73
A22369-1012	12 Colors	9.66	8.69



Maped Color'Peps Marker Jungle Set

This set of 12 colors includes a soft, flexible base that folds out into a stand for easy access, then folds back up for storage. The markers pop in and out of the base — no more lost marker caps! Conical soft tips dispense bright inks that are washable from most fabrics. The waterbased, non-toxic ink goes on smooth and bright, and will not bleed through most papers.

NUMBER	EACH	12/EA
A22374-1012	\$7.71	\$6.94



Maped Color'Peps Premium Glitter Markers

Add dazzling details to your drawings! These markers contain a large amount of glitter and have a fine conical tip for making fine lines and broad strokes. Their ultra-vivid colors lay down smooth. The set of eight markers includes one each of Black, Dark Blue, Light Blue, Orange, Purple, Red, Teal, and Yellow.

NUMBER	EACH	12/EA
A22381-1009	\$6.65	\$5.98



Maped Color'Peps My First Jumbo Markers

Designed for children just starting to create marker art, these jumbo markers have waterbased, non-toxic, ultra-washable ink that goes on smooth and bright — and won't bleed through most papers. The markers have clear, ventilated safety caps, and a 0.5 mm tip locked in both directions to prevent pushing in and tearing off. Ink washes easily from skin and most clothing.

NUMBER	SET	EACH	12/EA
A22379-1129	12 Colors	\$4.66	\$4.19



Sargent Art Dual Tip Markers

Sargent Art Dual Tip Markers offer twice the coloring fun as regular markers, with a fine bullet tip on one end and a brush tip on the other. Their triangular shape makes them easy to grip and control. Great for classroom settings, they're washable and non-toxic. A portable plastic carrying case keeps them organized and protected between uses. For set colors, visit DickBlick.com.

NUMBER	DESCRIPTION	EACH	12/EA
A00876-1024	24 Colors	\$18.05	\$16.23



Amodex Ink and Stain Remover

Safely and effectively remove ballpoint, felt tip, fountain pen, stamp pad, and even permanent marker and whiteboard marker ink, with this non-toxic, eco-friendly remover. Its cream soap formula works on hard surfaces, upholstery, wood, vinyl, skin, and most fabrics. It also removes crayon, paint, oil, grass and berry stains, wine, chocolate, tomato, blood, and more.

NUMBER	DESCRIPTION	EACH	12/EA
A04863-1005	0.5 oz Bottle	\$9.03	\$8.11
A04863-1001	1 oz Bottle	8.54	7.69
A04863-1004	4 oz Bottle	14.83	13.35
A04863-1010	Wipes, 10-pack	8.54	7.69



Blick® Broadline Water-Based Markers

These economical, long-lasting markers are built for rugged use. With durable chisel points, they give you flexible marking style to suit virtually any purpose. They dry quickly with minimal absorption. Safe and non-toxic, they are perfect for schools. The cap fits tightly to help prevent drying. Order from open stock to keep your classroom sets complete. Not washable from clothing and surfaces.



NUMBER	COLOR	EACH	12/EA
A21224-2001	Black	\$.51	\$ 4.46
A21224-5001	Blue	.51	.46
A21224-8031	Dark Brown	.51	.46
A21224-7001	Green	.51	.46
A21224-4501	Orange	.51	.46
A21224-6001	Purple	.51	.46
A21224-3001	Red	.51	.46
A21224-4001	Yellow	.51	.46
NUMBER	DESCRIPTION	EACH	12/EA
A21224-0089	Set of 8	\$3.61	\$3.25
A21224-2009	Classroom Pack of 200	66.10	59.50



Liqui-Mark® Washable Broadline Markers

A rainbow of colors, in washable ink that removes easily. Dried markers can be rejuvenated by dipping the tips in water. The caps are ventilated for child safety.

NUMBER	DESCRIPTION	EACH	12/EA
A21265-0109	10 Colors	\$4.99	\$4.50
A21265-2009	Class Pack of 200	62.45	56.21



Faber-Castell® DuoTip Washable Marker Sets

Twice the colors — for double the coloring fun! DuoTip Markers are filled with bright, long-lasting, waterbased inks that are easy to clean up. If a cap is left off, the marker nib can be rehydrated by placing it in water. Ventilated safety caps prevent choking.

NUMBER	SET	EACH	12/EA
A22314-0129	12 Assorted	\$5.50	\$4.95
A22314-0249	24 Assorted	10.59	9.53



Liqui-Mark® Marker School Packs

200-Pack Fine Point — Includes 25 each of Black, Blue, Brown, Green, Orange, Purple, Red, and Yellow, in a sturdy cardboard box.

NUMBER	EACH
A21220-0200	\$65.31

192-Pack Combo Fine and Broad Point — Includes 12 each of Black, Blue, Brown, Green, Orange, Purple, Red, and Yellow, in a sturdy cardboard box. 96 are fine point and 96 are broad point.

NUMBER	EACH
A21220-0192	\$77.06



Magic Stix™ Markers

Perfect for young artists, Magic Stix won't dry out—even after seven days without their caps, guaranteed! These bright, vivid colors are washable and non-toxic. They feature an easy-to-hold triangular barrel that won't roll off surfaces.

NUMBER	SET	EACH	12/EA
A22389-1012	12 Colors	\$5.50	\$4.95
A22389-1024	24 Colors	10.93	9.84



Manuscript® Lionheart Superwashable Pens

Featuring super washable ink and a jumbo size for easy grip, Manuscript Lionheart Superwashable Pens are ideal for young children just learning how to draw and write. Ink washes off skin and most fabrics with just water. Caps are ventilated for safety.

NUMBER	DESCRIPTION	EACH	10/EA
A65778-1001	Lionheart Superwashable Pens	\$9.89	\$8.90

Chromark™ Poster System
Easy sign making for schools!

Four pints of waterbased, non-toxic Chromark ink in Black, Blue, Red, and Yellow in a sign caddy. Ink has very little odor, does not bleed through even the thinnest butcher paper, and dries almost as fast as permanent ink. Each container holds 1" and 2" wide felt brush Chromarkers. One side of the felt is notched to create multi-line effects. All parts are color-coded.

NUMBER	EACH
A21317-0069	\$245.69

Chromark Ink in Pints

NUMBER	COLOR	EACH	9/EA	18/EA
A21317-2006	Black	\$18.55	\$16.70	\$15.83
A21317-5006	Blue	18.55	16.70	15.83
A21317-3006	Red	18.55	16.70	15.83
A21317-4006	Yellow	18.55	16.70	15.83



Prang® Art Markers

Create fine or broad lines with these sturdy bullet tip markers. The special bleedproof ink won't dry out, even if the cap is left off for 24 hours. The washable markers easily wash from skin and most clothing. All feature a ventilated safety cap.

NUMBER	SET	EACH	12/EA	24/EA
A21267-1089	8-ct Classic	\$3.91	\$3.52	\$3.34
A21267-1189	8-ct Washable	3.91	3.52	3.34
A21267-1129	12-ct Classic	5.30	4.77	4.53
A22307-1048	48-ct Tub	23.54	21.19	20.14



Prang® Washable Art Markers Master Pack

Rich, bold colors that won't bleed through paper! Super sturdy bullet tips create broad or fine lines. Ink won't dry out, even if the cap is left off for more than 24 hours. Washes easily off skin and most fabrics. Ventilated safety cap. Includes 25 each of eight popular colors that blend well: Black, Blue, Brown, Green, Orange, Purple, Red, and Yellow.

NUMBER	EACH	6/EA
A21267-2009	\$97.15	\$87.43



Prang® Fine Line Marker Sets

The 2 mm tip on Prang's fine line markers allows for detailed, accurate drawing. A high-quality ink formulation prevents bleedthrough, and the marker's streamlined design is comfortable to use.

NUMBER	SET	EACH	12/EA	24/EA
A21267-0129	12 Colors	\$5.18	\$4.66	\$4.43
A21267-0249	24 Colors	8.99	8.09	7.69
A22308-1096	96-ct Tub	19.79	17.81	16.92
A21267-1449	144 Class Pack	34.50	31.05	29.50



Mr. Sketch® Stix Markers

Mr. Sketch Stix Markers have a fine point, making them perfect for precise line drawing. These scented markers are specially formulated to easily wash from skin and clothing.

NUMBER	SET	EACH	SALE
A21299-9010	10 Scents	\$7.04	\$6.34
A21266-1010	Class Pack of 216	91.75	82.57



Sargent Art® Washable Fine Tip Marker Sets

Great for school, home, or office, these durable fine-tip markers come in a variety of vibrant, long-lasting colors. A child-safe breathable cap makes them ideal for younger children to use. The marker ink washes from skin and clothing with soap and water. The fine tip is great for drawing, illustrating — even writing! The 30-color and 50-color sets come in a handy plastic carrying case with handle.

NUMBER	SET	EACH	12/EA
A21295-1030	30 Colors	\$7.27	\$6.55
A21295-1050	50 Colors	10.64	9.57



Sargent Art® Classic Marker Sets

A high-quality felt tip, vibrant, long-lasting colors, and a child-safe vented cap make these markers great for younger children. Choose fine tip or broad tip. For set colors, visit DickBlick.com.

NUMBER	DESCRIPTION	EACH	12/EA
A22309-1089	Set of 8, Fine Tip	\$3.12	\$2.81
A22309-2089	Set of 8, Broad Tip	3.24	2.92
A22309-2009	Class Pack of 200, Broad Tip	80.68	72.63



Mr. Sketch® Markers

Bright, non-toxic, waterbased colors, each with its own fragrance, are safe and delightful to use. Broad wedge tips keep their shape even after months of coloring. For set contents, visit DickBlick.com.

NUMBER	DESCRIPTION	EACH	12/EA
A21215-0089	8 Colors	\$7.18	\$6.46
A21215-0129	12 Colors	11.14	10.03
A21215-1029	22 Colors	15.24	13.72
A21215-1929	192 Colors, Class Pack	155.99	140.39



Mr. Sketch® Washable Markers

Popular, vibrant Mr. Sketch colors are now available in a special formula that washes easily from skin and most clothing. All markers are scented.

NUMBER	SET	EACH	12/EA
A21201-1009	6 Colors	\$7.93	\$7.14
A21201-1149	14 Colors	16.27	14.64
A21201-1039	Class Pack of 192	217.97	196.17

Sargent Art® Washable Marker Sets

Great for school, home, or office, these durable markers come in a variety of vibrant, long-lasting colors that wash from skin and clothing with soap and water. Child-safe breathable caps make them ideal for smaller children to use. For drawing, illustrating, and writing. Sets of 200 include Black, Blue, Brown, Green, Orange, Red, Violet, and Yellow.

NUMBER	DESCRIPTION	EACH	12/EA
A22313-2009	Class Pack of 200, Broad Tip	\$86.15	\$77.52
A22313-2019	Class Pack of 200, Chisel Tip	95.60	86.03





Crayola® Gel Washable Markers

Create cool effects on black and colored paper, glossy paper, aluminum foil, Crayola Model Magic, and more! Won't bleed or blend. Classpack includes 10 sets of eight great colors each, and a lesson plan booklet.

NUMBER	SET	EACH	12/EA
A21257-0089	8 Assorted	\$6.59	\$5.93

Classpack® of 80 Markers

NUMBER	EACH	12/EA
A21257-0809	\$52.32	\$47.09



Crayola® Metallic and Glitter Marker Sets

Add a colorful shine and sparkle with Metallic and Glitter Markers. They're great for posters, cards, notebooks, and art projects of all kinds — anywhere you want to add a glittery accent or a metallic sheen. These strong, durable, long-lasting colors are non-toxic.

Glitter Set of 6 — Includes Silver Sparkle, Emerald Zest, Blue Blazes, Violet Glitz, Fire Flecks, and Gold Medal.

NUMBER	SET	EACH	12/EA
A22346-1069	6 Glitter	\$8.68	\$7.81

Metallic Set of 8 — Includes Purple Steel, Copper Mine, Green Machine, Slick Silver, Gold Ingot, Pink Bling, Black Iron, and Cobalt Blue.

NUMBER	SET	EACH	12/EA
A22347-1089	8 Metallic	\$9.13	\$8.22



Crayola® Ultra-Clean Washable® Multicultural Markers

A whole new level of color and clean! These markers wash both from skin and all children's clothing in one cold wash. Quick-drying, low-mess ink reduces smearing and bleed-through. Includes eight colors most often used for skin tones: Tan, Beige, Bronze, Tawny, Golden Beige, Terra Cotta, Mahogany, and Sienna. Conical tip produces thin and thick lines. 80-count Classpack contains 10 each of eight colors. Conforms to ASTM D-4236.

NUMBER	SET	EACH	12/EA
A21206-1709	8 Assorted	\$5.25	\$4.75

Classpack® of 80 Markers

NUMBER	EACH	6/EA
A21276-1080	\$49.15	\$44.23



Crayola® Washable Window Markers

Decorate windows, mirrors, glass, ceramic tile, rock, Mylar, and more with these opaque washable colors. Set includes White, Pink, Orange, Yellow, Blue, Green, Silver, and Gold in a reusable vinyl pouch.

NUMBER	EACH	12/EA
A21258-0089	\$5.97	\$5.37

A-B Crayola® 256-ct Combo Classpacks®

Variety, portability, and Crayola dependability come together in these big combo classpacks. Specially formulated for color intensity and durability, Crayola crayons and markers lay down the bright colors kids love. Classic colors include Black, Blue, Brown, Green, Orange, Red, Violet, and Yellow. Sturdy boxes are great for storage and organization.

A Large-Size Crayons and Washable Markers — 128 large-size crayons (4"L x 7/16"Dia) and 128 washable broadline markers, 16 each of eight colors. Marker ink washes easily from skin and clothing.

NUMBER	EACH	6/EA
A67812-2569	\$100.34	

B Regular-Size Crayons and Non-Washable Markers — 128 regular-size (3-5/8"L x 5/16"Dia) crayons and 128 non-washable broadline markers, 16 each of eight colors.

NUMBER	EACH	6/EA
A67812-1569	\$86.21	



Crayola® Pip-Squeaks™ Washable Markers

Pip-Squeaks markers are designed for ease of use by small hands. Colors wash easily from skin and most clothing.

16-Color Set — 16 markers in a reusable pouch. Colors include Copper Penny, Dinky Pink, Firefly Red, Golden Nugget, Kitten Gray, Leprechaun Green, Little Boy Blue, Little Lemon, Mini Brown, Petite Rose, Rain Drop Blue, Raspberry Squirt, Sweet Violet, Teensy Teal, Tiny Plum, and Toy Poodle Black.

NUMBER	SET	EACH	6/EA
A21275-1016	16 Assorted	\$6.85	\$6.16

Telescoping Marker Tower — The telescoping, tiered design of this tower allows children to easily access any one of 50 brightly colored markers. Tower folds down for easy storage.

NUMBER	SET	EACH	6/EA
A21275-0509	50 Assorted Tower	\$26.39	\$23.75



Crayola® Pip-Squeaks Skinnies® Markers

This is the largest collection of Crayola markers in one pack — with 64 colors that span the color spectrum. Perfect for little hands (age six and older). Each box contains a "Surprise Inside" of two stampers. Flip-top box and tiered sleeves offer easy access. Colors wash easily from skin and clothing.

NUMBER	EACH	12/EA
A21296-1009	\$17.15	\$15.43



Crayola® Super Tips Washable Markers

Super Tips feature a unique, durable tip that's smooth, not scratchy. Use the side for large areas, and the tip for details. Marker ink washes easily from skin and most clothing.

NUMBER	SET	EACH	12/EA
A21252-0109	10 Assorted	\$3.25	\$2.93
A21252-0209	20 Assorted	5.92	5.33
A21252-0509	50 Assorted	12.43	11.19
A21252-1019	100 Assorted	23.51	21.16

Crayola® Classic Ultra-Clean Washable® Markers

A whole new level of color and clean! These markers wash both from skin and all children's clothing in one cold wash. Specially selected color sets in a choice of tips make drawing more fun.

NUMBER	COLOR	EACH	12/EA	24/EA
A21206-2001	Black	\$.78	\$.69	\$.65
A21206-5001	Blue	.78	.69	.65
A21206-8001	Brown	.78	.69	.65
A21206-7001	Green	.78	.69	.65
A21206-4501	Orange	.78	.69	.65
A21206-3001	Red	.78	.69	.65
A21206-6501	Violet	.78	.69	.65
A21206-4001	Yellow	.78	.69	.65



Crayola® Ultra-Clean Washable® Marker Sets

Colors wash easily from skin, surfaces, and most clothing. For set colors, visit DickBlick.com.

NUMBER	SET	TIP STYLE	EACH	12/EA
A21206-1409	8 Classic	Broad	\$5.25	\$4.75
A21206-1509	8 Classic	Fine	5.25	4.75
A21206-0000	8 Tropical	Broad	5.25	4.75
A21206-1039	10 Bold	Broad	5.75	5.19
A21206-1049	10 Classic	Fine	5.75	5.19
A21206-1309	12 Classic	Broad	7.79	6.99
A21206-1809	12 Classic	Fine	7.79	6.99
A21206-1019	40 Classic	Broad	22.63	20.37
A21206-1029	40 Classic	Fine	22.63	20.37

200-ct Classpacks® — 25 each of Black, Violet, Yellow, Red, Green, Brown, Orange, and Blue.

NUMBER	TIP STYLE	EACH	6/EA
A21206-2200	Thin	\$111.39	\$100.25
A21206-1200	Broad	104.20	93.79



Crayola® Ultra-Clean Washable® Marker Classpacks®

200-Piece, 10-Color Pack, Thin-line Tip — 20 each of Red, Violet, Orange, Brown, Yellow, Black, Green, Blue, Flamingo Pink, and Dolphin Gray.

NUMBER	EACH	6/EA
A21206-2200	\$111.39	\$100.25

CRAYOLA®



Crayola® Classic Original Markers

Traditional, bright colors. The ink is waterbased but may not wash out of clothing. Made to withstand the most demanding school use. Broad tip.

NUMBER	COLOR	EACH	12/EA	24/EA
A21218-2001	Black	\$.52	\$.47	\$.45
A21218-5001	Blue	.52	.47	.45
A21218-8001	Brown	.52	.47	.45
A21218-7001	Green	.52	.47	.45
A21218-4501	Orange	.52	.47	.45
A21218-3001	Red	.52	.47	.45
A21218-6501	Violet	.52	.47	.45
A21218-4001	Yellow	.52	.47	.45

8-Color Set — One of each color above.

NUMBER	DESCRIPTION	EACH	12/EA	24/EA
A21218-1209	Broad	\$4.15	\$3.70	\$3.53
A21218-1309	Fine	4.15	3.70	3.53

12-Color Set — One of each color above, plus Sandy Tan, Blue Lagoon, Dolphin Gray, and Flamingo Pink. Broad tip.

NUMBER	EACH	12/EA	24/EA
A21218-1009	\$5.95	\$5.06	\$4.81

10-Color Sets — Includes Red, Orange, Yellow, Green, Blue, Violet, Brown, Black, Pink, and Gray. Broad or Fine tip.

NUMBER	DESCRIPTION	EACH	12/EA	24/EA
A21218-1010	Broad	\$4.68	\$4.08	\$3.88
A21218-2010	Fine	4.68	4.08	3.88



Crayola® Classic Original Marker Classpacks®

256-Piece Regular Broad Tip Markers — 16 each of Red, Blue, Green, Brown, Orange, Violet, Black, Yellow, Turquoise, Sandy Tan, Raspberry, Iguana Green, Flamingo Pink, Dolphin Gray, Tiger Orange, and Royal Purple, packed in a sturdy cardboard box.

NUMBER	EACH	6/EA
A21218-1109	\$104.99	\$94.29

200-Piece Fine Tip Markers — 20 each of Red, Blue, Green, Brown, Orange, Violet, Black, Yellow, Flamingo Pink, and Dolphin Gray, packed in a sturdy cardboard box.

NUMBER	EACH	6/EA
A21218-1001	\$94.99	\$85.30

NEW! QUICK QUOTE.
Create a quote on demand at
DickBlick.com

CRAYOLA®



Regular

Large

Jumbo

Crayons not shown to actual size.



Crayola® Regular Size Crayon Sets

Regular-size crayons measure 3-5/8"L x 5/16"Dia. For set contents, visit DickBlick.com.

NUMBER	SET	EACH	12/EA	24/EA
A20103-1038	8 Colors	\$1.13	\$1.03	\$0.98
A20103-1008	16 Colors	2.35	2.12	1.99
A20103-1019	24 Colors	2.45	2.20	2.09
A20103-1029	48 Colors	5.17	4.65	4.42
A20103-0649	64 Colors	6.35	6.10	5.79
A20103-1969	96 Colors	9.59	8.60	8.20
A20103-0120	120 Colors	13.55	12.15	11.25

Crayola® Regular Size Crayons in Bulk

Purchase 12 crayons of one color in a tuck box to refill classroom boxes.

NUMBER	COLOR	EACH	12/EA	24/EA
A20103-2009	Black	\$2.40	\$2.15	\$2.05
A20103-5009	Blue	2.40	2.15	2.05
A20103-8009	Brown	2.40	2.15	2.05
A20103-3059	Carnation Pink	2.40	2.15	2.05
A20103-4059	Gold	2.40	2.15	2.05
A20103-2569	Gray	2.40	2.15	2.05
A20103-7009	Green	2.40	2.15	2.05
A20103-4519	Orange	2.40	2.15	2.05
A20103-3359	Peach	2.40	2.15	2.05
A20103-3009	Red	2.40	2.15	2.05
A20103-9300	Silver	2.40	2.15	2.05
A20103-6009	Violet	2.40	2.15	2.05
A20103-1039	White	2.40	2.15	2.05
A20103-4009	Yellow	2.40	2.15	2.05

A Crayola® Ultra-Clean Washable® Regular Size Crayon Sets

Great for use at school or home, these crayons are specially designed to create less mess! They feature an Ultra-Clean formula that easily washes from skin, clothing, and even painted walls. Featuring classic colors as well as bright, fun shades, they inspire self-expression and imaginative play. Set of 64 includes a built-in sharpener. Crayons measure 3-5/8"L x 5/16"Dia.

NUMBER	SETS	EACH	12/EA
A20119-0029	24 Colors	\$5.10	\$4.59
A20119-0039	48 Colors	10.40	9.36
A20119-0064	64 Colors	13.71	12.34

B Crayola® Jumbo Crayon Sets

This jumbo (5"L x 9/16"Dia) size is easier for small children to grasp. Crayons are also double-wrapped for extra strength. For set colors, visit DickBlick.com.

NUMBER	DESCRIPTION	EACH	12/EA
A67809-1008	8 Colors	\$4.39	\$3.95
A67809-1016	16 Colors	8.56	7.70

C Crayola® Large Size Crayon Sets

Large-size crayons measure 4"L x 7/16"Dia. For set contents, visit DickBlick.com.

NUMBER	SET	EACH	12/EA	24/EA
A20104-1089	8 Colors	\$2.65	\$2.38	\$2.26
A20104-1016	16 Colors	5.40	4.86	4.62

Ultra-Clean Washable

NUMBER	SET	EACH	12/EA	24/EA
A20104-1068	8 Colors	\$3.24	\$2.92	\$2.77
A20104-1109	16 Colors	6.04	5.44	5.17

Crayola® Large Size Crayons in Bulk

Replenish your classroom boxes with these bulk packs. Each includes 12 crayons of the same color in a tuck box.

NUMBER	COLOR	EACH	12/EA	24/EA
A20104-2009	Black	\$4.60	\$4.14	\$3.93
A20104-5019	Blue	4.60	4.14	3.93
A20104-8009	Brown	4.60	4.14	3.93
A20104-2509	Gray	4.60	4.14	3.93
A20104-7019	Green	4.60	4.14	3.93
A20104-4519	Orange	4.60	4.14	3.93
A20104-3749	Pink	4.60	4.14	3.93
A20104-3009	Red	4.60	4.14	3.93
A20104-6000	Violet	4.60	4.14	3.93
A20104-1019	White	4.60	4.14	3.93
A20104-4009	Yellow	4.60	4.14	3.93



D

D Crayola® Silly Scents™ Mini Twistables® Crayons

Aromatic scents add extra fun to this set of 24 cool crayons. Great for coloring and drawing, they never need sharpening — just twist the barrel. Hands stay cleaner, too! For colors/scents, visit DickBlick.com.

NUMBER	EACH	12/EA	24/EA
A67847-1249	\$9.72	\$8.75	\$8.31

E NEW! Crayola® Colors of the World

Created to accurately represent people from every part of the globe, Crayola Colors of the World Crayons feature 24 diverse skin tone colors in three main shades, Almond, Golden and Rose, with all the darker and lighter shades in between. An essential addition to any Crayola collection, sets are perfect for the classroom, school projects, crafts, and more.

NUMBER	SET	EACH	12/EA	24/EA
A20103-1124	24 Colors	\$2.95	\$2.65	\$2.50
A20103-1001	Classpack, 480 ct	\$2.99	\$2.69	\$2.50

new!



E



F Crayola® Neon Crayons

Your projects will jump off the page when you use these vivid, neon colors. Double-wrapped for extra strength. Set of 8 colors. For children age four and older.

NUMBER	EACH	12/EA	24/EA
A67823-1008	\$1.13	\$9.99	\$9.94



G



I

G-H Crayola® Regular Size Crayon Classpacks®

Regular-size crayons measure 3-5/8"L x 5/16"Dia.

G 800-Piece, 8-Color Classpack® — Contains eight sets (100 of each color) in a sturdy box with individual compartments for each color. Colors include Black, Blue, Brown, Green, Orange, Red, Violet, and Yellow.

NUMBER	SET	EACH	6/EA
A20101-1019	800-Piece, 8 Colors	\$77.73	\$69.96

H 800-Piece, 16-Color Classpack® — Contains 16 sets (50 of each color) in a sturdy box with individual compartments for each color. Colors include Black, Blue, Blue-Green, Blue-Violet, Brown, Carnation Pink, Green, Orange, Red, Red-Orange, Red-Violet, Violet, White, Yellow, Yellow-Green, and Yellow-Orange.

NUMBER	SET	EACH	6/EA
A20101-1016	800-Piece, 16 Colors	\$77.73	\$69.96



Crayola® Ultimate Crayon Collection

The largest collection of Crayola crayons EVER! The Ultimate Crayon Collection includes 152 regular size crayons in a plastic caddy with a carrying handle, a lid, and a sharpener.

NUMBER	EACH	3/EA
A20103-1529	\$26.50	\$23.85



H



J

I Crayola® Large Size Crayon Classpack®

Contains 400 large size crayons in the following 8 assorted colors: Black, Blue, Brown, Green, Orange, Red, Violet, and Yellow.

NUMBER	SET	EACH	6/EA
A20101-1009	400-Piece, 8 Colors	\$72.73	\$65.46

J Crayola® Regular Size Crayon Classpack®

Here's value and convenience for the art educator — 832 regular size crayons in 13 reusable desktop bins. Each bin contains one set of 64 colors for easy distribution and storage. Also includes two classroom sharpeners.

NUMBER	SET	EACH	3/EA
A20103-1109	832-Piece, 64 Colors	\$79.35	\$71.25



My First Crayola® Palm-Grasp Crayons

Solid crayons in a fun, easy-to-grip shape! Designed to survive toddler-hood, these whimsical art tools are designed especially for the size and grip of a toddler's hands. The egg-shaped crayons are instinctive and comfortable to hold and play with, allowing for full control while drawing and coloring. Set of six crayons includes Blue, Green, Orange, Purple, Red, and Yellow. For age 12 months and older.

NUMBER	EACH	6/EA
A67844-1006	\$14.59	\$13.13



Crayola® Construction Paper Crayon Sets

These crayons deliver a consistent color laydown across all colors and types of paper, including black paper, cardboard boxes, and paper bags. Great for multicultural curriculums.

16-Color Set — Includes Black, Blue, Blue Green, Blue Violet, Brown, Carnation Pink, Green, Orange, Red, Red Orange, Red Violet, Violet, White, Yellow, Yellow Green, and Yellow Orange.

NUMBER	EACH	6/EA
A20117-1016	\$3.38	\$3.04

160-Piece, 8-Color Pack — Includes 20 each of White, Brown, Yellow, Violet, Blue, Green, Orange, and Pink.

NUMBER	EACH	6/EA
A20117-1609	\$54.63	\$49.17

400-ct Classpack — Includes 25 each of 16 colors in sturdy reusable packaging.

NUMBER	EACH	6/EA
A20117-4009	\$62.43	\$56.19



Crayola® Jumbo Size Crayon Classpack®

Jumbo-size crayons measure 5"L x 9/16"Dia. Contains 200 crayons, 25 each of Black, Blue, Brown, Green, Orange, Red, Violet, and Yellow.

NUMBER	SET	EACH	3/EA
A20113-1001	200-Piece, 8 Colors	\$78.74	\$70.87



Prang® Soy Crayons
Excellent quality — reasonably priced!
 Prang's exclusive blend of soybean oil and more intense pigments make these crayons brighter, smoother, and less flaky than ordinary wax crayons. Blend them together for an even more extensive color palette! Preferred by students and instructors.

NUMBER	SET	EACH	12/EA	24/EA
A20110-0089	8 Colors	\$.81	\$.73	\$.69
A20110-0169	16 Colors	1.32	1.19	1.13
A20110-0249	24 Colors	2.40	2.16	2.05



Sargent Art® Best Buy Crayon Packs
 Bright colors that won't smudge or flake but blend easily. Regular size 3-5/8" L x 5/16" Dia crayons. For set contents, visit DickBlick.com.

NUMBER	SET	EACH	12/EA	24/EA
A67814-1008	8 Colors	\$.63	\$.56	\$.52
A67814-1024	24 Colors	1.54	1.39	1.33

400-ct Set — 50 of each color in the 8-color set, in a durable storage box.

NUMBER	SET	EACH	12/EA
A67814-1400	400-ct Class Pack	\$36.24	\$32.61



Faber-Castell® Jumbo Beeswax Crayon Sets
 Perfect for little hands to hold, these jumbo beeswax crayons have a triangular shape that teaches children the proper grip and won't roll off desks or tables! Their beeswax formulation offers ultra-smooth, rich, vibrant color laydown, while the jumbo size makes them extra-thick, strong, and break-resistant.

NUMBER	SET	EACH	6/EA
A67825-0129	12 Colors	\$5.35	\$4.86
A67825-0249	24 Colors	12.31	11.08
A67825-2409	240-ct School Pack	74.93	67.45



Prang® Crayon Master Pack
 When you really need a lot of crayons, this is the most economical way to buy them. The Crayon Master Pack holds 800 crayons, 100 each of Black, Blue, Brown, Green, Orange, Purple, Red, and Yellow, in a durable storage box with a convenient carrying handle.

NUMBER	EACH	6/EA
A20110-8009	\$64.07	\$57.66



Lyra® Lyrax Wax-Giant Crayons
 The rounded triangular shape and giant 14.5 mm size make these break-resistant crayons ideal for small hands to grip. Made from high-quality, non-water-soluble pigments and genuine beeswax, they offer extraordinary color brilliance and opacity.

NUMBER	DESCRIPTION	EACH	5/EA
A67822-0069	6 Colors	\$11.45	\$10.30
A67822-0129	12 Colors	23.47	21.12



Sargent Art® Watercolor Crayons
 The unique formulation of these crayons lets you color and then use a wet brush to achieve a variety of watercolor effects. The 12-count lift lid box includes a brush. Each crayon measures 3-5/8" L x 5/16" Dia.

NUMBER	SET	EACH	12/EA
A67820-1008	8 Colors	\$5.66	\$5.19
A67820-1012	12 Colors	9.09	8.33
A67820-1024	24 Colors	18.19	16.68
A67820-1036	36 Colors	27.28	24.99



Maped® Color'Peps Gel Retractable Watercolor Crayons
 These ultra-smooth gel crayons lay down vibrant colors with almost no effort. Perfect for youngsters learning to color, their smooth cores are similar to oil pastels. Blend them, smear them, use them like watercolors for hours of coloring fun. The cores retract into a plastic body for a cleaner coloring experience on paper, cardboard, foam, foil, and more. Sets are packed in reusable hard plastic carrying cases. Set of 10 includes a free watercolor brush.

NUMBER	SET	EACH	8/EA
A67845-1006	Set of 6	\$5.86	\$5.27
A67845-1010	Set of 10 w/Brush	10.59	9.54



Liqui-Mark® Crayons
 Perfect for classroom art projects, coloring books and more, Liqui-Mark Crayons are non-toxic and mark in vivid, long-lasting color.

NUMBER	SET	EACH	12/EA
A87804-1249	24 Colors	\$1.53	\$1.37
A87804-2249	24 Global Colors	2.19	1.97



Faber-Castell® Watercolor Crayons
 It's easy for young artists to create watercolor art with these crayons — just add water using the included paintbrush to instantly mix a wide range of gorgeous colors. The crayons have more pigment and less wax, for brilliant colors, a smooth texture, and no waxy buildup. They're also acid-free. Includes 15 colors and a FREE paintbrush. For children age 3 and older. Conforms to ASTM D-4236.

NUMBER	SET	EACH	6/EA
A67828-1509	15 Colors with FREE Brush	\$16.64	\$14.98



Curves Floral Fantasy Leaves Triangles Kaleidoscope

Cedar Canyon Rubbing Plates

These generously sized, 7" x 7" plates are great for more than just traditional rubbings — use them to create unique patterns on fabric, clay, metal foil, paper castings, and more. Each package contains six unique plates of one style.

NUMBER	DESCRIPTION	EACH	6/EA
A62108-1020	Curves	\$13.75	\$12.38
A62108-1070	Doodles	13.75	12.38
A62108-1060	Floral Fantasy	13.75	12.38
A62108-1050	Kaleidoscope	13.75	12.38
A62108-1030	Leaves	13.75	12.38
A62108-1010	Op Art	13.75	12.38
A62108-1040	Triangles	13.75	12.38



Doodles Op Art

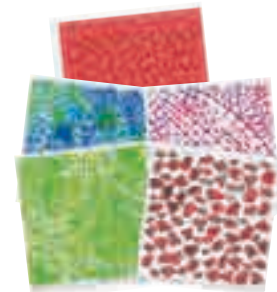

Animal Skins



Bugs



Fossils

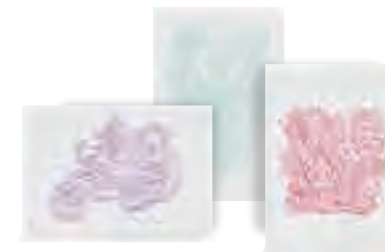

Henna



Optical Illusion



Textures



Flowers



Insects



Leaves



Monogram

Roylco® Rubbing Plate Sets

Blend art with science!

Place paper over the top of these high-impact plastic plates and rub with crayons to transfer fabulous designs and patterns, or use to emboss clay or foil projects. Idea guide and reference chart included.

NUMBER	DESCRIPTION	EACH	12/EA
A61112-6000	6 Animal Skins, 7" x 7"	\$13.77	\$12.39
A61112-2000	6 Bugs, 7" x 7"	13.77	12.39
A61112-1000	6 Fossils, 7" x 7"	12.65	11.38
A61112-1110	6 Henna, 7" x 10"	12.51	11.26
A61112-9000	6 Optical Illusion, 7" x 7"	13.77	12.39
A61112-3000	8 Textures, 8-1/2" x 11"	13.77	12.39
A61112-1080	16 Flowers, 4-1/2" x 6-1/2"	12.75	11.47
A61112-1070	16 Insects, 4-1/2" x 6-1/2"	12.75	11.47
A61112-1040	16 Leaves, 4" x 5"	12.75	11.47
A61112-1100	24 Monogram, 4-1/2" x 6"	19.65	17.68



Crayola® Colored Drawing Chalk

For drawing on paper and sidewalks. (Not recommended for chalkboards.) Strong, brilliant colors blend easily. Stick size is 3-3/16" L x 3/8" Dia. Choose 12-count box or 24-count box with one of each color or choose the box of 144 with six of each color.

NUMBER	DESCRIPTION	EACH	12/EA	24/EA
A20028-1012	Box of 12	\$3.56	\$3.20	\$3.04
A20028-1109	Box of 24	7.23	6.51	6.18
A20028-1009	Box of 144	24.51	22.06	20.96



Quartet® Alphacolor Colored Chalkboard Chalk

These brilliant chalks sticks write smoothly and erase easily. Sticks measure 3-1/4" x 7/16". 12-count box contains 8 assorted colors.

NUMBER	EACH	12/EA
A20021-1209	\$10.57	\$9.51



Prang® Freart Large Drawing Chalk

Carefully formulated from the finest pigments and binders to blend easily on any paper surface, these large 4" L x 1" Dia sticks come in a box of 12 exciting colors. They're great for sidewalks, too (although pressure-washing is required for complete removal). Not recommended for use on conventional chalkboards.

NUMBER	EACH	12/EA	24/EA
A20019-1409	\$19.16	\$17.24	\$16.38



Crayola® Washable Sidewalk Chalk

Washable sidewalk chalk for outdoor art! These 4-1/8" L x 3/4" W sticks come in sets of 12, 16, or 48.

NUMBER	DESCRIPTION	EACH	12/EA	24/EA
A20098-0129	12 Colors	\$3.39	\$3.05	\$2.90
A20098-0169	16 Colors	4.53	4.08	3.88
A20098-0489	48 Colors	8.78	7.90	7.50



Sargent Art® Sidewalk Chalk

It's concrete creativity! Kids will enjoy the limitless possibilities in this 30-stick carton of colorful sidewalk chalk. Easy-to-hold, large-size sticks won't break easily. Three sticks each of 10 colors.

NUMBER	EACH	12/EA	24/EA
A21928-1030	\$7.40	\$6.67	\$6.33



Prang® Ambrite Paper Chalk

A brilliantly colored, molded chalk for use on paper, cardboard, and a variety of other surfaces, Ambrite Paper Chalk has a soft, smooth texture that's ideal for posters, murals, stage props, sketching, and art projects of all kinds. The colors blend well on both dry and wet paper. The chalk is coated for cleaner handling. For greater color permanence, spray with fixative.

NUMBER	SET	EACH	6/EA	12/EA
A21987-1129	12 Colors	\$5.12	\$4.61	\$4.38
NUMBER	SET	EACH	3/EA	
A21987-1449	144 Color Class Pack	\$38.13	\$34.32	

Helpful for individuals with special needs.



Crayola® Anti-Dust® Chalk

This dustless chalk produces a clean, smooth line. Sticks measure 3" L x 5/16" Dia. Package of 144 White sticks contains 12, 12-stick boxes.

NUMBER	DESCRIPTION	EACH	12/EA	24/EA
A20022-1009	144-ct White	\$12.22	\$10.99	\$10.44

Colors — Brilliant colors for use on paper and surfaces other than chalkboards.

NUMBER	DESCRIPTION	EACH	12/EA	24/EA
A20099-1129	12-ct Color	\$.92	\$.83	\$.79



Sargent Art® Chalkboard Chalk

This dustless, non-toxic chalkboard chalk is available in 12-count sets of White or an assortment of colors.

NUMBER	COLOR	EACH	12/EA	24/EA
A21924-0129	Assorted	\$1.50	\$1.36	\$1.28
A21924-1029	White	1.07	.97	.91



Economy Felt Eraser

Value-priced eraser features six strips of dense felt sewn onto strong felt backing, providing excellent chalk absorption and cleaning power. 1" H x 2" D x 5" L.

NUMBER	EACH	12/EA	24/EA
A22891-2055	\$5.05	\$4.54	\$4.31



Deluxe Chamois Chalk Eraser

Deluxe eraser has a premium-quality, double-sewn chamois cover for complete chalkboard cleaning. Ideal for heavy-use environments and large writing surfaces. Superior chalk absorption and cleaning power. 12" L.

NUMBER	EACH	12/EA	24/EA
A22891-8712	\$29.85	\$26.88	\$25.52



Crayola® Oil Pastels 336-Count Classpack®

Bright, vivid, creamy pastels that blend beautifully on paper, in a jumbo size that is easier to grip and lasts longer. This sturdy, reusable classpack contains 24 each of 10 colors, and 48 each of White and Black. Sticks measure 3" L x 7/16" Dia.

NUMBER	EACH	6/EA
A20066-1336	\$56.59	\$50.90

Crayola® Oil Pastels

Smooth, creamy texture in true hues preferred by teachers. Hexagonal design keeps crayons from rolling off surfaces.

NUMBER	SET	EACH	12/EA	24/EA
A20066-1012	12 Assorted Neon Colors	\$6.63	\$5.97	\$5.65
A20066-1016	16 Assorted Colors	3.27	2.94	2.79
A20066-1028	28 Assorted Colors	5.20	4.67	4.45



Sargent Art® Artists' Oil Pastels

Sargent Art has combined deep, luxurious fine art colors with a smooth and easy blending texture to create an indispensable artist's tool. These oil pastels are designed to help artists of all ages develop their sketching and illustrating abilities.

Regular 2-5/8" x 3/8"

NUMBER	SET	EACH	12/EA
A21989-1212	12 Colors	\$2.55	\$2.29
A21989-1016	16 Colors	3.28	2.94
A21989-1025	25 Colors	4.65	3.43
A21989-1012	432-Piece Class Pack	63.61	57.24

Large 2-3/4" x 1/2"

NUMBER	SET	EACH	12/EA
A21989-1112	12 Colors	\$3.81	\$3.43
A21989-1024	24 Colors	7.05	6.34

Did you know we have hundreds of lesson plans designed to meet the National Standards for Visual Arts Education? See them all at DickBlick.com/lesson-plans.

WARNING! Products marked with a Prop 65 symbol (■ or ▼) can expose you to chemicals, including cadmium, which are known to the State of California to cause cancer and birth defects or other reproductive harm. For more information, visit P65Warnings.ca.gov.



Pentel Arts® Oil Pastels

Clear, brilliant colors that can be applied smoothly and blended easily. Colors are long-lasting and fade-resistant. Can be used on paper, board, or canvas. 2-1/2" long sticks.

NUMBER	SET	EACH	12/EA
A20020-1209	12 Colors	\$2.38	\$2.15
A20020-1609	16 Colors	3.20	2.88
A20020-2509	25 Colors	4.92	4.42
A20020-0369	36 Colors	6.65	5.97
A20020-5009	50 Colors	7.91	7.11

432-Count Classroom Pack

NUMBER	EACH
A20020-4329	\$65.94



Loew-Cornell® Oil Pastels

These inexpensive, beautifully blending pastels give the look of real oil color. Use on paper, board, canvas, textiles, or plaster. Paper-wrapped for neatness. Available in two sizes.

2-5/16" L x 5/16" Dia Sticks

NUMBER	SET	EACH	12/EA
A20037-1029	36 Colors	\$5.33	\$4.80
A20037-0009	60 Colors	8.73	7.86

2-3/4" L x 7/16" Dia Sticks

NUMBER	SET	EACH	12/EA
A20037-2009	24 Colors	\$7.71	\$6.94



Maped® Color'Peps Triangular Oil Pastels

This set of 24 extra-smooth oil pastels includes a variety of bright, blendable colors with strong covering power. Scratch, wipe, layer! They're easy to grip, thanks to their large, triangular size that's just perfect for small hands, plus they're paper-covered to keep hands clean.

NUMBER	EACH	12/EA
A22790-1024	\$7.03	\$6.33



Sakura Cray-Pas® Junior Artist Oil Pastels

Easy to use, fun, and safe, these student-quality oil pastels are used in classrooms worldwide. 2-3/8" L x 5/16" Dia sticks.

NUMBER	SET	EACH	12/EA	24/EA
A20013-2009	12 Black	\$3.11	\$2.47	\$2.35
A20013-1219	12 Colors	2.03	1.84	1.74
A20013-1009	12 White	3.11	2.47	2.35
A20013-1609	16 Colors	2.60	2.35	2.22
A20013-2509	25 Colors	3.92	3.42	3.22
A20013-5009	50 Colors	10.22	8.99	8.45
NUMBER	SET	EACH	3/EA	6/EA
A20031-0009	432 Color Class Pack	\$59.56	\$53.60	



288-Stick Jumbo Junior Artist Colorpack — Contains 288 jumbo, round sticks, 24 each of Brown, White, Pale Orange, Purple, Cobalt Blue, Green, Yellow Green, Orange, Pink, Red, Black, and Yellow. 2-3/4" L x 7/16" Dia sticks.

NUMBER	EACH	3/EA	6/EA
A20013-2889	\$88.15	\$83.49	\$79.32



Chubby Junior Artist Oil Pastels — Extra-wide (2-3/8" L x 7/10" Dia), paper-wrapped pastels in a 12-color set.

NUMBER	EACH	12/EA	24/EA
A20013-1209	\$9.75	\$8.78	\$8.33



Faber-Castell® Oil Pastel Sets

With an easy-to-handle triangular shape, these oil pastels are ideal for young artists. Rich, bright, opaque colors blend together easily and can be smoothed and thinned with baby oil. Each set includes a blending, shading, and tinting guide. The Class Pack has 24, 12-color sets. Sticks measure 2-3/4" L x 3/8" Dia.

NUMBER	SET	EACH	12/EA
A21931-1012	12 Colors	\$4.44	\$3.99
A21931-1024	24 Colors	8.85	7.96
A21931-1288	288 Color Class Pack	100.99	90.89



Portfolio® Series Oil Pastels

These creamy, water-soluble oil pastels are ideal for traditional oil pastel techniques. Available in a variety of bright, vivid colors, they can also be used with water to create watercolor effects. Each pastel is 3-1/4"L x 1/2"Dia.

NUMBER	SET	EACH	12/EA	24/EA
A20049-1012	12 Colors	\$5.34	\$4.81	\$4.57
A20049-1009	24 Colors	10.60	9.54	9.06

Class Pack — 300 sticks, 25 each of 12 colors.
 NUMBER EACH 6/EA
 A20049-3009 \$127.57 \$114.81



Sakura Cray-Pas® Expressionist™ Oil Pastels

Extra-fine quality pigments, waxes, and oils are especially formulated for very smooth drawing and a wide range of effects. From bold, intense strokes to subtle shading, the bright and vivid colors of Cray-Pas Expressionist Oil Pastels are suitable for many surfaces, including paper, board, canvas, and wood. 2-3/4"L x 7/16"Dia round pastels in paper sleeves.

NUMBER	SET	EACH	12/EA
A20012-0129	12 Colors	\$6.26	\$5.63
A20012-0169	16 Colors	8.03	7.19
A20012-0259	25 Colors	11.89	10.70
A20012-1019	36 Colors	22.35	20.12
A20012-0509	50 Colors	31.09	27.98
A20012-1129	12 Multicultural Colors	7.99	7.19

Individual Cray-Pas Expressionist Oil Pastels — Popular colors are listed here. For more colors, visit DickBlick.com. **Colors can be assorted for quantity pricing.**

NUMBER	COLOR	EACH	12/EA
A20012-2000	Black	\$.71	\$.63
A20012-5000	Blue	.71	.63
A20012-8000	Brown	.71	.63
A20012-7000	Green	.71	.63
A20012-4500	Orange	.71	.63
A20012-5010	Pale Blue	.71	.63
A20012-4510	Pale Orange	.71	.63
A20012-3050	Pink	.71	.63
A20012-3000	Red	.71	.63
A20012-8300	Van Dyke Brown	.71	.63
A20012-1000	White	.71	.63
A20012-4010	Yellow	.71	.63
A20012-7910	Yellow Green	.71	.63
A20012-0100	Extender	.71	.63



Niji® Oil Pastel Sets

Niji's high-quality yet reasonably priced soft oil pastels come in a variety of brilliant colors that blend and lift easily using stumps, odorless thinner, brushes, and palette knives. Suitable for canvas, paper, or board. Ideal for beginners as well as more advanced artists. Non-toxic.

NUMBER	SET	EACH	12/EA
A21911-1069	6 Fluorescent	\$5.86	\$5.08
A21911-0069	6 Metallic	5.86	5.08
A21911-0129	12 Colors	2.84	2.56
A21911-0249	24 Colors	5.59	4.91
A21911-0369	36 Colors	8.47	7.44



Van Gogh® Oil Pastel Sets

These soft, creamy sticks and strong colors lend themselves to many different drawing and painting techniques on a variety of surfaces. 2-3/4"L x 7/16"Dia round pastels in paper sleeves.

NUMBER	SET	EACH	5/EA
A20063-0009	12 Colors	\$20.17	\$18.15
A20063-0019	24 Colors	30.26	27.23
A20063-0060	60 Colors	75.34	67.81



Caran D'Ache® Neopastels

Neopastels are professional-quality oil pastels with superb smoothness and blendability. The permanent pigments are equally suited to intense coloring, delicate shading, or subtle transition of hue. Absolutely dustless. 2-1/2"L x 3/8"Dia. For individual Neopastels, visit DickBlick.com.

NUMBER	SET	EACH	6/EA
A20043-1209	12 Colors	\$34.10	\$30.69
A20043-2409	24 Colors	68.27	61.44
A20043-4809	48 Colors	135.12	121.61
A20043-0969	96 Colors	269.88	242.89



Caran D'Ache® Neocolor I Wax Pastels

These water-resistant crayons are soft and easy to work with. Great for underpainting, they feature exceptional covering power, a uniform texture, and excellent lightfastness. They sharpen easily for detail and edge work, and are soluble in mineral spirits for wash techniques. Use them on paper, cardboard, glass, leather, wood, and more. Sticks measure 4"L x 3/8"Dia.

NUMBER	SET	EACH	10/EA
A20067-0109	10 Colors	\$22.43	\$20.19
A21917-0109	10 Metallic Colors	27.09	24.38
A20067-0159	15 Colors	33.62	30.26



Sakura Cray-Pas® Specialist™ Oil Pastel Sets

Specifically developed and formulated to meet the demanding standards of professional artists, these pastels have exceptional color intensity and luminosity. Using high concentrations of extra-fine pigments, Sakura created extremely smooth and soft-textured pastels that are highly lightfast and suitable for any technique — from fine detail using their square corners, to glazing and wash techniques with a variety of oil painting mediums. 2-1/2"L x 3/8"Sqr pastels, unwrapped.

NUMBER	SET	EACH	12/EA
A20047-1012	12 Colors	\$22.69	\$20.42
A20047-0359	25 Colors	47.29	42.56
A20047-1009	36 Colors	66.47	59.82
A20047-0509	50 Colors	94.44	86.55



Faber-Castell® Goldfaber Studio Oil Pastels

Premium pastels at an unbeatable price! This collection of 36 brilliant colors is very soft and easy to blend, providing smooth color laydown for rich oil pastel effects. Good lightfastness and excellent opacity. Sticks measure 2-3/4"L x 3/8"Dia.

NUMBER	SET	EACH	12/EA
A21905-0129	12 Colors	\$7.07	\$6.52
A21905-0249	24 Colors	14.14	13.04
A21905-0369	36 Colors	21.21	19.56



Holbein® Academic Oil Pastels

These superior student-grade oil pastels feature smooth, even pigmentation and no hard spots or bubbles. They handle, blend, and clean easily and can be used on virtually any surface. They're ideal for quick sketching and student use. Individual pastels are paper-wrapped and measure 2-3/4"L x 13/32"Dia.

NUMBER	SET	EACH	6/EA
A21913-0129	12 Colors	\$13.21	\$11.89
A21913-0169	16 Colors	17.62	15.86
A21913-0249	24 Colors	24.23	21.81
A21913-0369	36 Colors	35.95	32.35
A21913-0489	48 Colors	45.78	41.21



Lyra® Aquacolor Crayon Sets

These highly pigmented, velvety smooth, water-soluble artists' crayons dissolve easily and produce creamy color blends. Apply dry and release with water from a brush or blender. The lightfast 3-1/2"L x 3/8"Dia sticks are available in three different color assortments and beautifully arranged in metal tins.

NUMBER	SET	EACH	6/EA
A20204-0129	12 Colors	\$19.63	\$17.67
A20204-0249	24 Colors	39.14	35.23
A20204-0369	48 Colors	78.27	70.44

Sennelier® D'Artigny Oil Pastel Fixative

Made from a vinyl resin and alcohol base, this totally transparent fixative leaves a clear and glossy film to protect oil pastels against dust and smearing. 13.5 oz (400 ml) aerosol spray.

NUMBER	EACH	6/EA
A21700-1004	\$20.10	\$18.09

Sennelier® Oil Pastel Sets

Beautiful oil pastels, made in Paris. Creamy smooth and workable, each contains pure pigments for maximum lightfastness, brilliance, color intensity, and opacity. Paper-wrapped 2-5/8" long sticks.

NUMBER	SET	EACH	3/EA
A20093-0069	6 Colors	\$19.99	\$17.99
A20093-0129	12 Starter	45.88	41.29
A20093-1129	12 Iridescent	45.88	41.29
A20093-2249	24 Landscape	78.93	71.03
A20093-3249	24 Portrait	78.93	71.03
A20093-4249	24 Still Life	78.93	71.03
A20093-1249	24 Universal	78.18	70.34
A20093-0489	48 Universal	159.17	143.25

Sennelier® Oil Pastel Grand

Each Grand pastel stick measures 5"L x 3/4"Dia, nearly eight times the weight and volume of standard Sennelier oil pastel sticks. For more colors, visit DickBlick.com. **Colors can be assorted for quantity pricing.**

NUMBER	COLOR	EACH	3/EA
A20091-5311	Ash Blue	\$11.50	\$10.35
A20091-2021	Black	11.50	10.35
A20091-5861	Blue Gray	11.50	10.35
A20091-5391	Blue Violet	11.50	10.35
A20091-3771	Bordeaux	11.50	10.35
A20091-4291	Bright Yellow	11.50	10.35
A20091-8481	Brown Pink	11.50	10.35
A20091-4941	Chinese Orange	11.50	10.35
A20091-7931	Cinnabar Green Yellow	11.50	10.35
A20091-5181	Cobalt Blue	11.50	10.35
A20091-3241	Coral	11.50	10.35
A20091-5211	Delft Blue	11.50	10.35
A20091-3801	Flesh Ochre	11.50	10.35
A20091-7971	Green Yellow Light	11.50	10.35
A20091-1001	Iridescent Aluminum	11.50	10.35
A20091-1091	Iridescent White Pearl	11.50	10.35
A20091-4911	Mandarin	11.50	10.35
A20091-2041	Mars Black	11.50	10.35
A20091-3741	Permanent Intense Red	11.50	10.35
A20091-5221	Prussian Blue	11.50	10.35
A20091-3711	Red Deep	11.50	10.35
A20091-3011	Red Light	11.50	10.35
A20091-3371	Ruby Red	11.50	10.35
A20091-1011	Transparent Medium	11.50	10.35
A20091-1021	White	11.50	10.35
A20091-4321	Yellow Deep	11.50	10.35
A20091-4931	Yellow Lake	11.50	10.35
A20091-4041	Yellow Ochre	11.50	10.35

Sets FOB Factory. See page 648 for details.
 NUMBER SET EACH 3/EA
 AF20094-0369 Universal, 36 Color Wood Box \$421.00 \$378.00

Ranger Tim Holtz® Distress Crayons

Distress Crayons are formulated to achieve vibrant coloring effects on porous surfaces. Ideal for mixed media, their smooth, water-reactive pigments can be used to create brilliant backgrounds, watercoloring, smudge effects, and more. Color directly onto your surface and blend with water, then layer with Distress Inks or Stains for even more creative possibilities. Sets coordinate with the Tim Holtz Distress palette. For set colors, visit DickBlick.com.

NUMBER	DESCRIPTION	EACH	6/EA
A19540-1019	Set 1	\$14.32	\$12.89
A19540-1029	Set 2	14.32	12.89
A19540-1039	Set 3	14.32	12.89



4-Piece Pastel Blending Set

Includes two Pastel Shapers (one soft taper point, one flat chisel), a Soft Blender Brush, and a nylon Fan Brush. Seamless ferrules with short, matte black handles. Cleanup is easy with mild soap or brush cleaner.

NUMBER	SIZE	APPROX. DIA.	EACH	3/EA
A06927-1009	2	3/16"	\$33.05	\$29.75
A06927-1019	6	5/16"	44.09	39.69



Cretacolor® AquaStics

Exceptional water-solubility, high pigmentation, and softness make AquaStics suitable for many drawing techniques, including blending and sgraffito. Use them on canvas, wood, glass, and more. Exceptionally lightfast, they also blend beautifully. Metallic AquaStics have a shimmering gloss-metallic finish. Sticks measure 3-9/10"L x 1/3"Dia.

NUMBER	SET	EACH	6/EA
A21927-1010	10 Assorted Colors	\$25.16	\$22.65
A21927-1110	10 Metallic Colors	25.16	22.65
A21927-1020	20 Assorted Colors	51.60	45.45
A21927-1040	40 Assorted Colors	97.64	87.88



Caran d'Ache® Neocolor II Watersoluble Artists' Crayon Sets

Softer than colored pencils, denser than children's wax crayons, and extremely responsive to a wet brush, Neocolor II Crayons are great for combining wet and dry techniques. Each crayon measures 4-1/8"L x 5/16"Dia.

NUMBER	SET	EACH	3/EA
A20042-1009	10 Colors	\$22.43	\$20.19
A20042-1509	15 Colors	33.57	30.21
A20042-3009	30 Colors	66.98	60.28
A20042-0409	40 Colors	89.54	80.59
A20042-0849	84 Colors	188.17	169.35
A20042-1080	84 Colors Wood Box	395.00	355.00





Blick® Pastels

Brilliant, rich, full-pigment pastels are made with fine-quality raw materials. These 2-1/2"L x 3/8"Sqr pastels blend easily for a beautiful, smooth texture. Class pack contains 12 each of 12 colors in reusable trays.

NUMBER	SET	EACH	12/EA
A20016-1009	12 Colors	\$6.29	\$5.65
A20016-0129	12 Earthtones	6.29	5.65
A20016-1129	12 Graytones	6.29	5.65
A20016-2129	12 Charcoal	6.29	5.65
A20016-1109	24 Colors	9.75	8.79
A20016-0249	24 Landscape	9.75	8.79
A20016-1249	24 Portrait	9.75	8.79
A20016-0489	48 Colors	17.63	15.89
A20016-1449	144 Class Pack	45.45	40.90



Prang® Pastello

Pressed colored chalk crayons with a firm, dustless consistency, for drawing on paper. Pastellos blend well, and light colors can even be applied over darker hues. Set of 24, 3-1/4"L x 5/16"Sqr sticks.

NUMBER	EACH	12/EA	24/EA
A20027-2409	\$11.44	\$10.30	\$9.78



Richeson® Semi-Hard Square Pastel Sets

Richeson's professional, semi-hard pastel sticks are perfect for underpainting. Their square shape is ideal for shading, and they can also be sharpened to a point if desired. Sticks measure 3-5/8"L x 3/8"Sqr.

NUMBER	SET	EACH	6/EA
A21941-1209	12 Colors	\$16.21	\$14.59
A21941-1809	18 Colors	24.35	21.92
A21941-3609	36 Colors	48.92	44.03
A21941-7209	72 Colors	93.48	84.13
A21941-1120	120 Colors	144.44	129.99



Alphacolor® Pastels

Rich in pigment, with a velvety texture. 2-5/8"L x 3/8"Sqr sticks set in plastic trays.

Basic Color Sets — The 12-stick set has primary and secondary colors; 24-stick set adds tertiary colors; the 48-stick set adds two Blacks, two Whites, four assorted Grays, and four assorted Fluorescents; the 144-stick set has 24 colors — six of each.

NUMBER	SET	EACH	12/EA
A20024-0309	3 Charcoal	\$3.05	\$2.75
A20024-1009	3 White	3.05	2.75
A20024-1229	12 Colors	9.39	8.45
A20024-1219	12 Earth Tone	9.77	8.79
A20024-1209	12 Fluorescent	16.40	15.42
A20024-1239	12 Gray	9.77	8.79
A20024-2429	24 Colors	15.69	14.78
A20024-2419	24 Portrait	15.69	14.78
A20024-4809	48 Colors	30.86	26.26
A20024-1449	144 Colors	66.86	60.18



Cretacolor® Pastel Carré Hard Pastels

Unburnt artists' chalk guarantees brilliant colors and high lightfastness, thanks to superior pigmentation. All colors can be mixed together, smudged, or dissolved with water. They are characterized by especially soft, oil-free strokes. Fixing is required. The square shape makes for easy handling. Each stick measures 2-3/4"L x 1/4"Sqr.

NUMBER	SET	EACH	12/EA
A20077-2509	8 Gray Colors	\$19.50	\$17.56
A20077-8529	8 Sanguine Colors	19.50	17.56
A20077-0059	12 Starter Colors	27.12	24.41
A20077-0009	24 Basic Colors in Metal Box	41.88	37.70
A20077-0029	72 Complete Colors	95.32	85.79



Sargent Art® Square Chalk Pastels

These square chalk pastels are a great value for the classroom or fine artists. With a velvety smooth, dry texture and brilliant, concentrated pigmentation, this softer-style medium is available in color assortments to suit every need. A soft, user-friendly formula blends easily and allows superior color control. Use to create aged effects on paper. Acid-free. Sticks are 2-1/2"L x 3/8"Sqr.

NUMBER	SET	EACH	12/EA	24/EA
A21930-3012	12 Charcoal	\$7.18	\$6.47	\$6.15
A21930-1012	12 Colors	7.18	6.47	6.15
A21930-2012	12 Earthtone	7.18	6.47	6.15
A21930-4012	12 Graytone	7.18	6.47	6.15
A21930-1024	24 Colors	11.09	9.99	9.48
A21930-2024	24 Landscape	11.09	9.99	9.48
A21930-3024	24 Portrait	11.09	9.99	9.48
A21930-1032	32 Half Stick	13.19	11.87	11.28
A21930-1048	48 Colors	21.53	19.37	18.41

Chalk Pastel Classroom Pack — Pack includes 144 chalk pastels, six each of 24 colors.

NUMBER	EACH	12/EA	24/EA
A21930-1144	\$58.99	\$53.12	\$50.46

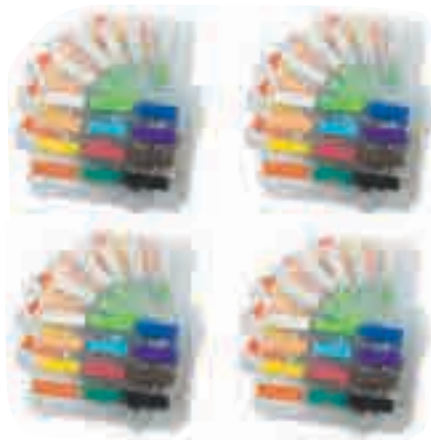

ProArt® Soft Pastels Class Pack

These pigment-rich pastels come in a range of bold, vibrant colors, with a square shape that's ideal for making broad strokes and fine, crisp details. A great tool for practicing both painting and drawing disciplines, the colors blend well to create an infinite range of tones. Classpack includes 24 clamshell cases, each containing 12 pastels and a blending stump.

NUMBER	EACH	6/EA
A21991-1024	\$47.38	\$42.65



20 Colors, Painting

Metallic Painting

Pearlescent Painting

PanPastel® Sets

Highly pigmented artist-quality pastels are offered in stacking, interlocking jars. The ultra-soft, low-dust formulation blends and applies easily and affords more control than traditional pastel sticks.

NUMBER	SET	EACH	6/EA
A21934-5059	5 Blues	\$28.34	\$25.51
A21934-3005	5 Ex Dark Earth	28.34	25.51
A21934-1005	5 Ex Dark Shades	28.34	25.51
A21934-2005	5 Ex Dark Shadows	28.34	25.51
A21934-4059	5 Grays	28.34	25.51
A21934-1059	5 Painting Colors	28.34	25.51
A21934-3059	5 Shades	28.34	25.51
A21934-2059	5 Tints	28.34	25.51
A21934-1009	6 Metallic Painting Colors	46.97	42.27
A21934-1609	6 Metallics	33.14	29.82
A21934-0559	6 Pearlescent Painting Colors	46.97	42.27
A21934-1017	7 Basic Foundation Colors	46.97	42.27
A21934-1007	7 Explrng Mixed Media I	46.97	42.27
A21934-1107	7 Explrng Mixed Media II	46.97	42.27
A21934-1049	7 Lia Griffith Designer Colors	46.97	42.27
A21934-1027	7 Starter Landscape Colors	46.97	42.27
A21934-1037	7 Starter Portrait Colors	46.97	42.27
A21934-1047	7 Sketch & Tone Colors	46.97	42.27
A21934-2109	10 Drawing Colors	59.27	53.34
A21934-2010	10 Ex Dark Cool Colors	59.27	53.34
A21934-1010	10 Ex Dark Warm Colors	59.27	53.34
A21934-4109	10 Greens	59.27	53.34
A21934-1109	10 Painting Colors	59.27	53.34
A21934-0669	10 Priscot Colors & Mediums	70.84	63.76
A21934-3109	10 Seascape Colors	59.27	53.34
A21934-1120	20 Ex Dark Shades	94.99	85.50
A21934-1069	20 Joanne Barby General Painting Colors	108.74	97.86
A21934-1079	20 Joanne Barby Seascape Colors	108.74	97.86
A21934-2209	20 Landscape Colors	94.99	85.50
A21934-1209	20 Painting Colors	94.99	85.50
A21934-3209	20 Portrait Colors	94.99	85.50
A21934-2049	20 Shades	94.99	85.50
A21934-2039	20 Tints	94.99	85.50
A21934-0809	80 Colors	436.00	393.00

PanPastel® Mediums

These are true pastel mediums for creating pearl (fine) and sparkly (coarse) effects in your pastel paintings. Use White to create tints, and Black to create darks and shades for rich, jewel-like effects. The Colorless Blender can be mixed with any PanPastel color to create a variety of transparent effects. It's also great for softening and blending edges.

NUMBER	DESCRIPTION	EACH	6/EA
A21934-1000	Colorless Blender	\$8.58	\$7.70
A21934-0305	Black, Fine	8.58	7.70
A21934-0405	Black, Coarse	8.58	7.70
A21934-0105	White, Fine	8.58	7.70
A21934-0205	White, Coarse	8.58	7.70
A21934-0119	Set of 5 Mediums	35.67	32.10

Prismacolor® NuPastel Color Sticks

NuPastels have a rich, creamy texture that blends and shades easily. Frequently used in advertising layouts, NuPastels are stronger than ordinary soft pastels, which means less breakage and easier cleanup. Use them to create broad strokes and fine lines. Each stick measures 3-5/8"L x 1/4"Sqr.

NUMBER	SET	EACH	6/EA
A20034-1209	12 Colors	\$15.42	\$13.88
A20034-2419	24 Colors	30.90	27.81
A20034-3609	36 Colors	46.35	41.71
A20034-4809	48 Colors	61.82	55.64
A20034-9609	96 Colors	120.63	108.57

Individual NuPastel Color Sticks

NUMBER	COLOR
A20034-5911	Azure Blue
A20034-7003	Beech Green
A20034-2003	Black
A20034-5091	Blue Haze
A20034-5391	Blue Violet
A20034-7004	Bottle Green
A20034-3081	Buff
A20034-3141	Burgundy
A20034-4701	Burnt Orange
A20034-8703	Burnt Sienna
A20034-8050	Burnt Umber
A20034-4281	Cadmium Yellow Deep
A20034-3150	Carmine
A20034-3191	Carmine Madder
A20034-3003	Carnival Red
A20034-5081	Ceylon Blue
A20034-4151	Chrome Yellow
A20034-7913	Citrine Green
A20034-8361	Cocoa Brown
A20034-2831	Cold Deep Grey
A20034-2811	Cold Light Grey
A20034-2523	Cold Medium Grey
A20034-2801	Cold Very Light Grey
A20034-4911	Colonial Yellow
A20034-3241	Coral
A20034-7111	Cordovan
A20034-4811	Corn Yellow
A20034-3161	Crimson Red
A20034-7031	Dark Green
A20034-3291	Dark Rose
A20034-5461	Deep Blue
A20034-7191	Eden Green
A20034-7051	Emerald Green
A20034-7291	Endive Green
A20034-7391	Erin Green
A20034-7491	Fern Green
A20034-3091	Flamingo
A20034-3721	Garnet
A20034-5913	Harbor Blue
A20034-7121	Hooker's Green
A20034-6591	Hyacinth Violet
A20034-3251	Indian Red
A20034-5200	Indigo Blue
A20034-5191	Iron Blue
A20034-1043	Ivory

NUMBER	EACH	12/EA
A20034-1003	\$1.51	\$1.36



Richeson® Street Stix Pavement Pastels

Developed especially for use by street artists, these jumbo-sized, 2-3/4"L x 3/4"Dia pastels are ideal for long-lasting sidewalk paintings, murals, and other outdoor art. Their large size makes them easy to use, they blend beautifully, and they resist crumbling when applied to rough surfaces. Street Stix contain the same vibrant pigments that Richeson Pastels are known for. Choose from 60 vibrant colors and a variety of sets. For set contents, visit DickBlick.com.

NUMBER	SET	EACH	6/EA
A21972-0039	3 Colors	\$21.78	\$19.60
A21972-0069	6 Colors	32.90	29.61
A21972-0129	12 Colors	65.71	59.14



Individual NuPastel Color Sticks

NUMBER	COLOR
A20034-4063	Lemon Yellow
A20034-5013	Light Blue
A20034-4793	Light Naples Yellow
A20034-4833	Light Ochre
A20034-7081	Light Sap Green
A20034-5291	Light Turquoise
A20034-3713	Madder Pink
A20034-3341	Maroon
A20034-7791	Neptune Green
A20034-8091	Nut Brown
A20034-6033	Old Lilac
A20034-3391	Old Rose
A20034-7071	Olive Green
A20034-4511	Orange
A20034-6421	Orchid
A20034-6491	Orchid Pink
A20034-3761	Pale Vermilion
A20034-7743	Palm Green
A20034-3350	Peach
A20034-5211	Peacock Blue
A20034-3401	Persian Rose
A20034-7891	Pistachio Green
A20034-6171	Plum
A20034-5221	Prussian Blue
A20034-8061	Raw Sienna
A20034-3771	Red Violet
A20034-3714	Rose Pink
A20034-3591	Rust
A20034-3511	Salmon Pink
A20034-8000	Sandlewood
A20034-8523	Sanguine
A20034-7093	Sap Green
A20034-3181	Scarlet
A20034-8081	Sepia
A20034-3571	Shell Pink
A20034-7891	Smoke Green
A20034-5951	Spruce Blue
A20034-5921	Tile Blue
A20034-8911	Titian Brown
A20034-5111	Turquoise Blue
A20034-3731	Tuscan Red
A20034-5233	Ultramarine Blue
A20034-8311	Van Dyke Brown
A20034-7901	Veronese Green
A20034-6503	Violet
A20034-7871	Viridian Green
A20034-2331	Warm Deep Grey
A20034-2311	Warm Light Grey
A20034-2321	Warm Medium Grey
A20034-2693	Warm Very Light Grey
A20034-1003	White

NUMBER	EACH	12/EA
A20034-1003	\$1.51	\$1.36



Conté à Paris® Crayon Color Sets

Highest quality, rich, vibrant pigments in a fine kaolin clay base. Thinner and harder than traditional pastels, ideally suited for drawing and sketching. Sticks measure 2-1/2"L x 1/4"Sqr.

NUMBER	SET	EACH	12/EA
A20201-0149	4 Matchbox Set	\$4.67	\$4.20
A20201-1019	12 Assorted	26.15	23.53
A20201-1129	12 Landscape	26.15	23.53
A20201-1409	12 Portrait	26.15	23.53
A20201-1109	24 Assorted	51.77	46.59
A20201-1209	48 Assorted	99.19	89.27



Blick® Artists' Pastel Sets

Professional quality at an affordable price! With a velvety texture that offers easy laydown and consistent coverage, Blick Artists' Pastels are great for blending, layering, and softening edges — all with a minimum of crumbling. Offered in a variety of rich, vibrant colors and soft hues, they're created by combining the finest pigments with a minimal amount of binder. They're also extremely lightfast. Individual sticks measure 2-1/2"L x 1/2"Dia.

NUMBER	SET	EACH	3/EA
A21948-1509	15 Colors	\$47.42	\$42.67
A21948-0309	30 Portrait Colors	83.69	75.32
A21948-3009	30 Colors	83.96	75.56
A21948-1309	30 Landscape Colors	83.96	75.56
A21948-4509	45 Colors	125.85	113.26
A21948-9009	90 Colors	202.89	182.60
A21948-1809	180 Colors	461.00	415.00



Blick® Artists' Pastel Half Stick Sets

Enjoy access to twice the colors and twice the creative possibilities with Blick Artists' Soft Pastel Half Stick sets! Choose sets of 20, 40, 60, or 120 half sticks. The mixed set of 140 contains 60 full-size sticks and 80 half sticks. Half sticks measure 1-1/4"L x 1/2"Dia.

NUMBER	SET	EACH	3/EA
A21948-1209	20 Colors	\$35.49	\$31.94
A21948-1409	40 Colors	59.70	53.73
A21948-1606	60 Colors	83.84	75.46
A21948-1219	120 Colors	159.83	143.84
A21948-1419	140 Colors	232.21	208.99



Rembrandt® Pastels

Rembrandt soft pastels have an unsurpassed purity and intensity. Made from the best-quality, finely ground, pure pigments in an extra-fine kaolin clay binder — no hard bits or sharp edges. Each 2-3/4"L x 3/8"Dia stick is paper-wrapped.

NUMBER	SET	EACH
A20026-1009	15 Assorted Colors	\$67.06
A20026-0159	15 Color Wood Box	82.77
A20026-1519	15 Dark Colors	67.06
A20026-0309	30 Landscape	118.69
A20026-2309	30 Portrait	118.69
A20026-0459	45 Assorted	171.33
A20026-1045	45 Landscp Wood Box	242.09
A20026-1145	45 Portrait Wood Box	242.09
A20026-0120	60 Full & 60 Half Stks	335.00
A20026-0029	90 Landscape	335.00
A20026-0039	90 Portrait	335.00
A20026-0049	150 Assorted Wood Box	738.00
A20026-0059	225 Assorted Wood Box	1125.00

Rembrandt Pastel Half Sticks — 1-3/8"L x 3/8"Dia.

NUMBER	SET	EACH
A20026-1209	15 Assorted Colors	\$42.63
A20026-1309	30 Assorted Colors	67.06
A20026-1130	30 Half Stick Wood Box	82.77
A20026-1019	60 Assorted Colors	118.69
A20026-0909	90 Assorted Colors	174.71

Rembrandt Pastel Half Sticks — 1-3/8"L x 3/8"Dia.

NUMBER	COLOR	EACH
A20026-2511	Black 700.5	\$4.74
A20026-5371	Blue Violet 548.7	4.74
A20026-7851	Bluish Green 640.5	4.74
A20026-8751	Burnt Sienna 411.5	4.74
A20026-8791	Burnt Sienna 411.9	4.74
A20026-8771	Burnt Sienna 411.7	4.74
A20026-8651	Burnt Umber 409.5	4.74
A20026-8671	Burnt Umber 409.7	4.74
A20026-3181	Carmine Light 318.8	4.74
A20026-7041	Cinnabar Grn Dp 627.3	4.74
A20026-4421	Deep Yellow 1 202.12	4.74
A20026-4451	Deep Yellow 2 202.5	4.74
A20026-9171	Gold Ochre 231.7	4.74
A20026-2981	Gray 1 704.8	4.74
A20026-2951	Gray 2 704.5	4.74
A20026-4021	Lemon Yellow 205.12	4.74
A20026-4851	Light Yellow 1 201.5	4.74
A20026-3481	Madder Lake Deep 331.5	4.74
A20026-7231	Olive Green 620.3	4.74
A20026-7251	Olive Green 620.5	4.74
A20026-4651	Orange 235.5	4.74
A20026-7451	Permanent Grn 618.5	4.74
A20026-7331	Perm Green Dp 1 619.3	4.74
A20026-7351	Perm Green Dp 2 619.5	4.74
A20026-3851	Perm Red Light 370.5	4.74
A20026-3971	Permanent Rose 397.7	4.74
A20026-5761	Phthalo Blue 570.5	4.74
A20026-5231	Prussian Blue 1 508.3	4.74
A20026-5271	Prussian Blue 2 508.7	4.74
A20026-8851	Raw Umber 408.5	4.74
A20026-8871	Raw Umber 408.7	4.74
A20026-5021	Red Violet 1 545.3	4.74
A20026-5011	Red Violet 2 545.5	4.74
A20026-5261	Ultramarine Deep 506.5	4.74
A20026-5361	Ultramarine Dp 506.7	4.74
A20026-3651	Violet 536.5	4.74
A20026-1051	White 100.5	4.74
A20026-4151	Yellow Ochre 227.5	4.74
A20026-4171	Yellow Ochre 227.7	4.74
A20026-4191	Yellow Ochre 227.9	4.74



Sennelier® Pastels à l'écu Sets

Only the purest pigments are mixed with minimal amounts of natural binders to make these extra-soft pastels. Lightfast and watersoluble, they produce powerful, brilliant lines of color. Stick size is 2-1/2"L x 3/8"Dia.

NUMBER	SET	EACH	3/EA
A20036-2129	12 Intro Colors	\$55.11	\$49.60
A20036-0249	24 Colors	119.77	107.80
A20036-1059	24 Dark	119.77	107.80
A20036-1249	24 Iridescent	119.77	107.80
A20036-1069	24 Landscape	119.77	107.80
A20036-1099	48 Landscape	227.73	204.99
A20036-1109	48 Portrait	227.73	204.99

Sennelier Pastel Half Sticks — Each pastel is 1-1/4"L x 1/2"Dia.

NUMBER	SET	EACH	3/EA
A20036-1009	20 Colors	\$53.30	\$47.97
A20036-1019	40 Colors	99.47	89.53
A20036-1049	80 Colors	172.33	155.10
A20036-1209	120 Paris Colors	250.59	225.60



Faber-Castell® Studio Soft Pastel Sets

Very soft and smooth, these 1-1/4"L x 5/16"Sqr half sticks have excellent opacity and great blending characteristics. Priced for students and beginning artists.

NUMBER	SET	EACH	12/EA
A20000-1024	24 Colors	\$11.41	\$10.15
A20000-1048	48 Colors	22.12	19.91
A20087-0729	72 Colors	33.15	29.83



Unison® Handmade Pastel Sets

John Hersey began producing handmade pastels by lightly rolling each pastel so that the pigment was softly compressed, resulting in fluid color unlike any other pastel. While other manufacturers add white or black to make up a color set, Unison uses pure pigments with a cycle of related hues and a very minimal amount of binder for intense, strong color. Sticks are approximately 2"L x 1/2"Dia.

NUMBER	SET	EACH	3/EA
A20048-1018	18 Dark	\$124.43	\$111.97
A20048-1059	18 Landscape	124.43	111.97
A20048-0018	18 Light	124.43	111.97
A20048-1049	18 Portrait	124.43	111.97
A20048-1039	18 Starter	124.43	111.97
A20048-1029	36 Landscape	231.52	208.37
A20048-1019	36 Portrait	231.52	208.37
A20048-0729	72 Landscape	438.00	394.00
A20048-1009	72 Professional	438.00	394.00

General's® MultiPastel® Pencils

These high-quality chalk pencils are handcrafted in the USA using a smooth, acid-free, pigment-rich formula. They can be blended easily with a finger, paper stump, kneaded eraser, or tissue. For a dramatic effect, use them on a dark colored paper with a rough surface. The pre-sharpened pencils are encased in cedar and tipped with an extra-soft vinyl eraser. Use them for traditional fine arts, and for creating lettering, outlining, borders, shading, accents, and aging effects in scrapbooks, memory books, and more.

NUMBER	SET	EACH	6/EA
A20533-1022	2 White	\$3.43	\$3.09
A20533-1009	12 Colors	18.92	17.03
A20533-2009	24 Colors	34.42	32.10



General's® Multi-Pastel® Pencil Classroom Pack

This economical class pack includes one dozen each of Black, Canary Yellow, Green, Indigo Blue, Light Flesh, Light Gray, Orange, Pink, Scarlet Red, Van Dyke Brown, Violet, and White. Also includes 12 Portrait Lesson booklets, 12 Pastel Chalk Pencil technique booklets, and 12 All-Art sharpeners.

NUMBER	EACH	3/EA
A20533-1109	\$183.99	\$165.60



Derwent® Pastel Pencil Sets

Derwent Pastel Pencils offer all the expressive qualities of the pastel in the convenience of a pencil form. These professional-quality pencils are ideal for use as an individual medium or for detailing in combination with pastel work. Specially developed to provide only the highest degree of purity and lightfastness.

NUMBER	SET	EACH	6/EA
A20007-1009	12 Colors	\$36.65	\$32.98
A20007-1109	24 Colors	73.31	65.98
A20007-1019	72 Colors	207.48	186.80



Stabilo® CarbOthello Pastel Pencil Sets

These German-made pencils are world famous for their quality. Semi-soft in wood-cased pencil form, these opaque, watersoluble colors blend beautifully and erase easily. The large-diameter lead can make broad strokes or be sharpened to a fine point for details and lettering. Each set is packaged in a metal box with a hinged lid.

NUMBER	SET	EACH	12/EA
A20009-1012	12 Colors	\$24.80	\$22.32
A20009-1009	24 Colors	45.42	40.89
A20009-1019	36 Colors	69.56	62.60
A20009-1048	48 Colors	97.76	87.99
A20009-1060	60 Colors	111.11	99.99
A21433-1001	Sharpener	4.30	3.87



Cretacolor® Pastel Pencil Sets

Durable cedar wood-cased pencils are intermixable and feature brilliant color and high lightfastness. Pencil pastels are characterized by especially soft, oil-free strokes. Fixing is required. Color-coded tip permits easy identification. The colors are mixable, wipeable, and soluble. In hinged metal boxes.

NUMBER	SET	EACH	3/EA
A20547-0009	12 Colors	\$25.13	\$22.62
A20547-0019	24 Colors	46.91	42.22
A20547-0039	36 Colors	68.60	61.75
A20547-0049	72 Colors	127.34	114.60



Koh-I-Noor® Gioconda™ Soft Pastel Pencil Sets

Gioconda Soft Pastel Pencils offer the smooth finish of conventional pastels without the mess. Highly pigmented with a buttery smooth feel, they have excellent blending and toning characteristics on dark or light mediums. Lightfast and fade-resistant, with California cedar wood casings for crisp and accurate sharpening with minimal waste.

NUMBER	SET	EACH	12/EA
A22033-0129	12 Colors	\$27.75	\$24.98
A22033-0249	24 Colors	58.17	52.36
A22033-0369	36 Colors	87.33	78.61
A22033-0489	48 Colors	110.79	99.72



Conté à Paris® Pastel Pencil Sets

These large-diameter pencils have very fine, smooth cores that are richly pigmented for creating precise marks or lines on a variety of papers. Abrasives provide toning and stumping ability.

NUMBER	SET	EACH	3/EA
A20517-1009	12 Colors	\$33.95	\$30.56
A20517-1109	24 Colors	57.36	51.63
A20517-1209	48 Colors	114.93	103.44



Caran d'Ache® Pastel Pencil Sets

Carefully selected by leading pastel artists, these assortments are intended both for beginners and experienced amateur or professional artists. Use them for preliminary work or detailed finishing of pastel paintings. Packaged in a cardboard box.

NUMBER	SET	EACH	6/EA
A21964-1129	12 Colors	\$59.85	\$53.86
A21964-1209	20 Colors	99.75	89.77
A21964-1409	40 Colors	199.44	179.50
A21964-1009	76 Colors	358.00	322.00



Faber-Castell® Pitt® Pastel Pencil Sets

Suitable for lines, shading, delicate color transitions, and extended areas. The pigment-rich colors will not change upon fixing or exposure to light. Wood-cased leads are oil-free and must be fixed to protect drawings. Individual lightfastness ratings are printed on each pencil's casing. In metal boxes.

NUMBER	SET	EACH	3/EA
A20546-0009	12 Colors	\$28.16	\$25.54
A20546-0019	24 Colors	52.36	47.63
A20546-0029	36 Colors	76.35	68.72
A20546-0609	60 Colors	125.69	113.12



Prismacolor® Watercolor Pencil Sets
Coordinate with Prismacolor pencils and Verithins.

Mix and combine your favorite Prismacolors with their water-soluble counterparts and enjoy the same professional quality you've come to expect.

NUMBER	SET	EACH	12/EA
A20528-0019	12 Colors	\$22.20	\$19.98
A20528-0029	24 Colors	43.42	39.08
A20528-0039	36 Colors	61.40	55.26

General's® Kimberly® Watercolor Pencils

Draw and paint at the same time with these strong, water-soluble colored pencils. Colors are vibrant and blendable, and respond like watercolor when wet. Blend with a brush or draw directly into washes.

Dip pencils into water for intense color or make your own "dry pencil palette" to paint with by sketching and then lifting with a brush. Made in USA.

NUMBER	SET	EACH	12/EA	24/EA
A20502-1039	4 Blues and Greens	\$6.70	\$6.03	\$5.72
A20502-1029	4 Neutral Colors	6.70	6.03	5.72
A20502-1009	4 Southwest Colors	6.70	6.03	5.72
A20502-1019	4 Urban Colors	6.70	6.03	5.72
A20502-0809	8 Colors	9.82	8.83	8.35
A20502-1209	12 Colors	13.50	12.15	11.54
A20502-2409	24 Colors	23.49	21.14	20.09

Kimberly 144-Pencil Class Pack — Includes 12 each of Black, Blue, Brown, Carmine, Green, Light Blue, Light Green, Orange, Pink, Purple, Red, and Yellow.

NUMBER	EACH	6/EA
A20502-9012	\$144.24	\$129.82



Pentel Arts® Watercolor Colored Pencil Sets

Vibrant colors from pure pigments make these watercolor pencils ideal for creating both watercolor effects and precise details in your drawings and watercolor paintings. They're even great for adding a splash of color to journals. Thick cores are glued the entire length of the premium wood casing, making them long-lasting and break-resistant. Pre-sharpened.

NUMBER	SET	EACH	6/EA
A22476-1129	12 Colors	\$7.45	\$6.68
A22476-1249	24 Colors	15.77	14.19
A22476-1361	36 Colors	23.65	21.28



Crayola® Watercolor Pencil Sets

Your favorite Crayola pencils in a water-soluble form. Use them with a wet brush or dip in water and draw. Set of 12 or 24 brilliant colors, pre-sharpened, in an easel pack.

NUMBER	SET	EACH	12/EA
A20522-1009	12 Colors	\$4.21	\$3.79
A20522-0009	24 Colors	7.92	7.13



Crayola® 240-Watercolor Pencil Classpack®

This sturdy, convenient box holds 20 each of 12 vibrant colors, including Red, Blue, Green, Yellow, Violet, Orange, Black, Brown, White, Sky Blue, Magenta, and Yellow-Green. Pre-sharpened.

NUMBER	EACH
A20522-2009	\$76.17



Sargent Art® Watercolor Pencil Set of 240

These exceptional watercolor pencils are priced for the beginner but have the high quality that professionals look for. They can be used to create a variety of special effects with the addition of water.

240-Count Set — Includes 20 each of 12 colors, including Red, Brown, Green, Blue, Yellow-Green, Magenta, Yellow, Orange, White, Light Blue, Light Violet, and Black.

NUMBER	EACH	6/EA
A20589-2409	\$53.77	\$48.40



Fantasia Watercolor Pencils

Produced with selected pigments to assure high color concentration and perfect water-solubility, Fantasia Watercolor Pencils are also suitable for dry blending. These affordable pencils are FSC-certified.

NUMBER	SET	EACH	4/EA
A22458-1129	12 Colors	\$14.16	\$12.75
A22458-1249	24 Colors	18.46	16.61
A22458-1369	36 Colors	27.35	24.62



Derwent® Academy Watercolor Pencils

Learning how to paint with watercolors can be tricky, which is where these versatile watercolor pencils come into play. Use them dry for fine details and backgrounds, or draw a wet brush over your strokes to create fluid watercolor effects. The rich pigments dissolve and blend easily to create a variety of shades. Hexagonal barrels assure control and precision.

NUMBER	SET	EACH	6/EA
A22416-1012	12 Colors	\$13.90	\$13.13
A22416-1024	24 Colors	27.99	26.25



STAEDTLER® Triangular Watercolor Pencils

These watercolor pencils offer smooth, color-intensive performance. Excellent for blending, they have triangular barrels that are easy to grip. The pre-sharpened pencils are easy to re-sharpen.

NUMBER	SET	EACH	12/EA
A22455-1012	12 Colors	\$8.11	\$7.30



Caran D'Ache® Supracolor® Soft Aquarelle Pencil Sets

Professional-quality water-soluble colored pencils with exceptional covering power and excellent lightfastness to meet the most exacting demands of artists and illustrators. Use them wet or dry for unlimited blending techniques. Thick 3.7 mm core; hexagonal shape. In hinge-lid metal gift boxes. Made in Switzerland.

NUMBER	SET	EACH	6/EA
A20542-1129	12 Colors	\$32.38	\$29.14
A20542-1189	18 Colors	48.57	43.71
A20542-1309	30 Colors	80.94	72.85
A20535-0409	40 Colors	113.03	101.73



Cretacolor® Watercolor Pencils

Woodless pencils from Austria. Pure colored cores are encased in a thin layer of lacquer. Both fine lines and big surfaces can be painted with these unique aquarelle colored pencils. They are easily sharpened with a standard pencil sharpener. Wherever a watercolor result is desired, simply rework the applied color with water and brush.

NUMBER	SET	EACH	6/EA
A20536-1209	12 Colors	\$32.50	\$29.55
A20536-2409	24 Colors	58.21	52.92



Derwent® Graphitint Pencil Sets

Derwent Graphitint Pencils combine the character of a graphite pencil with a hint of color. These exciting drawing pencils are soft and smooth and can be blended to produce an endless array of soft hues. Add water and the color becomes more vibrant. Colors can be modified or removed with a soft eraser or a brush and clean water. The colors range from soft grays, blues, and greens to fantastic russets, plums, and browns.

NUMBER	SET	EACH	6/EA
A22039-0129	12 Colors	\$31.94	\$28.75
A22039-0249	24 Colors	63.84	57.46



Derwent® Ink Intense Sets

Versatile as watercolor pencils, but with a firmer texture that makes them perform with the brilliant intensity of pen-and-ink. Use them dry for intense color; wash out with water for a translucent effect. When dry, color is permanent and may be worked over with other media.

NUMBER	SET	EACH	6/EA
A22051-1006	6 Colors	\$16.19	\$14.57
A22051-1012	12 Colors	32.20	28.98
A22051-1024	24 Colors	64.37	57.92
A22051-1036	36 Colors	96.40	86.77
A22051-1072	72 Colors	193.15	173.84



Derwent® Ink Intense Block Sets

Derwent Ink Intense Blocks are just like your favorite Ink Intense pencils in block form. They're great for filling in large areas using dry techniques — or wash over your work with water to create watercolor effects.

NUMBER	SET	EACH	6/EA
A22412-1012	12 Colors	\$37.37	\$33.63
A22412-1024	24 Colors	74.73	67.25
A22412-1036	36 Colors	111.66	100.45
A22412-1072	72 Colors	201.17	181.05



Faber-Castell® Goldfaber™ Aqua Watercolor Pencil Sets

Created for students and hobby artists, these water-soluble pencils can be used dry, then washed over with a wet brush to transform colored pencil drawings into watercolor paintings. The highly pigmented 3.3 mm cores are soft yet very break-resistant. Every pencil offers good color laydown, maximum opacity, and a high degree of lightfastness. Made in Germany. Sturdy metal boxes.

Colored Pencil Sets

NUMBER	DESCRIPTION	EACH	6/EA
A22651-1129	Set of 12 in Tin	\$13.08	\$11.73
A22651-1249	Set of 24 in Tin	25.99	23.39
A22651-1369	Set of 36 in Tin	38.71	34.84
A22651-1489	Set of 48 in Tin	51.61	46.44
A22651-1449	144ct Class Pack	154.18	138.77



Derwent® Watercolor Pencil Sets

These professional-quality, water-soluble pencils offer artists the freedom to switch from drawing to painting in an instant, with no change in tools. Shade with them on dry paper, then quickly wash over with brush and water to achieve a blending effect. Use wetted paper for intensified colors yet softened edges, or try wetting the pencil first for rich, textured lines.

NUMBER	SET	EACH	6/EA
A20505-1009	12 Colors	\$24.30	\$23.99
A20505-1109	24 Colors	48.43	43.59
A20505-1209	36 Colors	72.57	65.30
A20505-1309	72 Colors	145.79	131.22
A20505-1509	72 Colors Wood Box	250.50	225.45

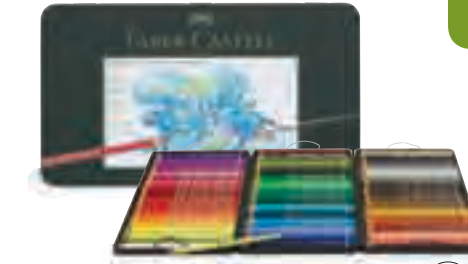

Faber-Castell® Albrecht Dürer Watercolor Pencil Sets

Smooth color laydown is effortlessly blended when wet for layered effects, highlights, and transitions, and permanent when dry for rich, lasting color. These pencils have the highest-quality pigments with extra-thick 3.8 mm leads that are break-resistant, water-soluble, and deliver sharp, fine lines. Barrels are premium California cedar wood with Secureall bonding to help prevent breakage. Colors are extremely lightfast.

NUMBER	SET	EACH	6/EA
A20567-1069	6 Color Tin	\$15.56	\$13.99
A20567-0129	12 Color Tin	31.89	28.69
A20567-0249	24 Color Tin	63.29	56.95
A20567-0609	60 Color Tin	131.23	118.10
A20567-1209	120 Color Tin	256.61	230.95
A20567-1369	36 Color Gift Box	84.85	76.36



Caran D'Ache® Museum Aquarelle Pencil Sets

Caran d'Ache has developed an innovative approach to watercolor painting by combining a high concentration of extra-fine pigments with excellent water-solubility to create Museum Aquarelle pencils. These bright, vibrant colors are extremely lightfast and perfectly suited to watercolor painting and artistic drawing. Can be applied dry or wet.

NUMBER	SET	EACH	6/EA
A22451-1012	12 Intro Colors	\$59.13	\$53.22
A22451-1020	20 Landscape Colors	98.57	88.71
A22451-1120	20 Marine Colors	98.57	88.71
A22451-1009	40 Assorted Colors	172.11	154.90
A22451-1019	76 Assorted Colors	336.00	302.00



A



B



C



D



E



462-ct Classpack

A Crayola® Colored Pencil Sets

These bright, vibrant pencils have thick 3.3 mm cores for easy sharpening and smooth color laydown. Pre-sharpened.

NUMBER	SET	EACH	12/EA	24/EA
A20519-1008	8 Colors	\$2.30	\$1.95	\$1.85
A20519-1009	12 Colors	3.25	2.61	2.48
A20519-1209	24 Colors	6.31	5.80	5.50
A20519-0369	36 Colors	9.20	8.32	7.90
A20519-1309	50 Colors	12.57	10.20	9.68
A20519-1019	100 Colors	27.75	25.04	23.79

240-ct Classpack® — Includes 20 each of 12 colors, including Orange, Sky Blue, Black, Red, Yellow, Red-Orange, Yellow-Green, Brown, Blue, Violet, Green, and White, plus 12 hand-held pencil sharpeners.

NUMBER	EACH	6/EA
A20519-1109	\$53.30	\$48.09

462-ct Classpack® — Includes 35 each of Red, Orange, Yellow, Green, Blue, Black, and White; and 31 each of Raspberry, Red-Orange, Yellow-Green, Green-Blue, Navy Blue, Violet, and Brown. Also includes 12 hand-held pencil sharpeners.

NUMBER	EACH	6/EA
A20519-1119	\$96.87	\$87.36

B Crayola® Metallic Colored Pencils

Give children glittering metallic colors to enhance their drawings and creativity. Set of eight colors includes Mauve, Blue, Purple, Silver, Gold, Green, Copper, and Bronze.

NUMBER	EACH	12/EA	24/EA
A20530-0009	\$4.80	\$4.32	\$4.10



F



G

C Crayola® Colors of the World Colored Pencils

Specially designed to accurately represent people from every corner of the globe, Crayola Colors of the World includes new skin tone colors to make coloring pages and drawings even more detailed and realistic. Colors of the World fall into three main shades: Almond, Golden and Rose – with all the darker and lighter shades in between.

NUMBER	DESCRIPTION	EACH	12/EA	24/EA
A20519-1024	24-Color Colored Pencils	\$4.19	\$3.77	\$3.58

D Crayola® eXtreme Colors Colored Pencils

Add even more color to your artwork with Crayola eXtreme Colors! These super-bright neon colored pencils are ideal for beginning scribblers — or for more advanced artists who want to kick it up a notch. Laydown is smooth, pencils are easy to sharpen, and a reusable box keeps your pencils organized. Pack of eight includes Fiery Rose, Sizzling Sunset, Heat Wave, Lemon Glacier, Spring Frost, Absolute Zero, Winter Sky, and Arctic Lime.

NUMBER	EACH	12/EA	24/EA
A22401-1008	\$4.88	\$4.39	\$4.17

E Crayola® Color Sticks

Crayola Color Sticks look great on both colored and white paper! Made of solid color so there's no sharpening waste, they have an easy-to-hold pentagonal shape with five points for thin lines or writing, and five flat sides for broad strokes. They resist breaking and last a long time. The 12-color box includes Black, White, Violet, Blue, Sky Blue, Green, Yellow-Green, Yellow, Red, Orange, Red-Orange, and Brown. For contents of other sets, visit DickBlick.com.

NUMBER	SET	EACH	12/EA
A22083-1009	12 Colors	\$9.63	\$8.67
A22083-1024	24 Colors	18.62	16.76
A22083-1120	120-ct Classpack	94.67	85.20

F Crayola® Silly Scents™ Colored Pencils

Add dimension and fun to colored pencil drawings with Silly Scents! These 12 fragrant colored pencils combine enticing smells with fun names like Cotton Candy, Licorice, and Marshmallow. Each aromatic art tool comes ready to scribble and sniff. Pre-sharpened pencils lay down silky smooth colors. For set colors, visit DickBlick.com.

NUMBER	EACH	3/EA	6/EA
A22659-1209	\$5.65	\$19.52	\$18.54

G Crayola® Twistables® Colored Pencils

No need for sharpening — just turn the end of these pencils, watch the colored 2.0 mm core twist up through the clear barrel, and you're good to go! Both sets include vibrant colors such as Lime Green, Mango, and Magenta, plus neon colors. The clear vinyl pouch is great for storage.

NUMBER	SET	EACH	12/EA	24/EA
A20125-0129	12 Colors	\$5.60	\$5.05	\$4.79
A22056-0189	18 Colors	7.82	7.03	6.68



Jolly X-Big Colored Pencils

Extra-big cores (6.4 mm) offer great coverage, perfect for little hands! Great for developing fine motor skills, the 11 mm pine barrels are sustainably harvested and contain no additives or preservatives. These sturdy pencils are virtually impossible to break! For children age two and older. Class pack of 180 includes 15 each of 12 colors.

NUMBER	DESCRIPTION	EACH
A20398-1009	12 ct	\$15.26
A20398-1019	Class Pack of 180	206.71



H



I

H Lyra™ Skin Tone Giant Pencil Set

Developed to represent the world's most common skin tones for rendering subjects in their true skin color, these pencils are 10 mm thick, with a 6.5 mm lead that has been dipped in wax to give it a soft touch and break-resistance. Set of 12 colors.

NUMBER	EACH	3/EA	6/EA
A20591-0129	\$21.69	\$19.52	\$18.54

I Lyra™ Color Giants® Sets

Lyra Color Giants are in a class of their own! Their highly pigmented, extra-thick, break-resistant cores last three times longer than regular colored pencils. Colors are brilliant, lightfast, smudgeproof, and waterproof. Hexagonal lacquered pencils come in a 12-pack of assorted colors and a six-pack of metallic colors.

NUMBER	SET	EACH	5/EA
A22096-1006	6 Metallic	\$13.51	\$12.16
A22096-1012	12 Assorted	24.29	21.86



Jolly Superstick Colored Pencil Class Packs

Available in a variety of bright colors, Jolly Supersticks have strong, long-lasting cores that are glued the length of the pencil to prevent loosening. The sustainably harvested, all-natural pine barrels contain no additives or preservatives. Pre-sharpened pencils come in stackable plastic boxes. Includes 24 each of 12 colors. 3.8 mm cores and 8 mm diameter barrels. For set colors, visit DickBlick.com.

Regular, 288-ct — Includes 24 each of 12 colors. Regular size pencils have 3.8 mm cores and 8 mm barrels.

NUMBER	EACH
A20349-1288	\$262.74

X-Big, 180-ct — Includes 15 each of 12 colors. X-Big pencils have 6.4 mm cores and 11 mm barrels.

NUMBER	EACH
A20398-1019	\$206.71

BLICK® essentials colored pencils

quality and value

An essential tool for any classroom or art class, Blick Essentials Colored Pencils have break-resistant 3.3 mm cores that assure great color laydown for drawing, coloring, and blending. Quality pigments result in bold colors that young artists love. The pre-sharpened pencils are 7" long and sharpen easily. For colors, visit DickBlick.com.

NUMBER	SET	EACH	12/EA
A22429-0129	12 Colors	\$2.53	\$2.28
A22429-0249	24 Colors	4.05	3.65

Class Pack — Contains 20 each of 12 colors, including White, Yellow, Red-Orange, Orange, Red, Yellow-Green, Green, Light Blue, Blue, Purple, Brown, and Black.

NUMBER	SET	EACH	12/EA
A22429-2409	240-ct Class Pack	\$63.99	\$57.59



Stabilo® Woody 3 in 1 Pencils

This chunky pencil functions as a colored pencil, watercolor, and wax crayon all in one — perfect for a variety of techniques. The extra-thick, 10 mm core is as thick as eight standard colored pencils, resists breakage, and provides soft, rich strokes that exhibit high luminosity, opacity, and color intensity even on dark papers. Outstanding watercolor properties make it ideal to paint with. It also writes on smooth surfaces such as glass, metal, leather, and more. Ideal for large surfaces — and for small hands!

NUMBER	SET	EACH	6/EA
A22092-1006	6 Colors w/sharpener	\$17.03	\$15.33
A22092-1010	10 Colors w/sharpener	24.77	22.29



Faber Castell® World Colors EcoPencil Colored Pencil Sets

Help celebrate creativity, inclusion, and self-expression with Faber-Castell World Colors EcoPencil Sets. Sets include 12 or 24 single-color pencils, and three double-ended pencils containing six blendable skin tones for creating almost any skin shade.

NUMBER	EACH	12/EA
A22688-1009	\$3.82	\$3.42
A22688-1019	7.64	6.88

Faber-Castell® Red-Line Metallic Pencils

Ordinary drawings become extraordinary with metallic colors that shimmer and sparkle when they catch the light. Especially effective when used on dark paper, these pencils feature smooth, opaque pigments and thick, long-lasting leads that resist cracking. What's more, Faber-Castell's Red-Line factory operates its own tree nursery to leave the forest untouched. The Class Pack contains 20 each (individually boxed) of 12 colors. For color names, visit DickBlick.com.

NUMBER	SET	EACH	12/EA
A20552-1012	12 Colors	\$8.30	\$7.67
A20552-2409	240-ct Class Pack	117.99	106.20



Faber-Castell® Goldfaber Color Pencils and Sets

Specially created for students and hobby artists, these colored pencils are also a great choice for more advanced artists. Perfect for both colored pencil drawings and mixed media work, they have 3.3 mm cores that lay down smudgeproof, water-resistant, lightfast marks. The highly pigmented cores are soft yet break-resistant, even on rough surfaces. Metal boxes. Made in Germany.

NUMBER	DESCRIPTION	EACH	6/EA
A22651-1129	Set of 12 in Tin	\$13.08	\$11.73
A22651-1249	Set of 24 in Tin	25.99	23.39
A22651-1369	Set of 36 in Tin	38.71	34.84
A22651-1489	Set of 48 in Tin	51.61	46.44

Classpack of 144 — Includes 12 each of Black, Burnt Ochre, Cadmium Yellow, Dark Cadmium Orange, Emerald Green, Grass Green, Light Blue, Middle Purple Pink, Pale Geranium Lake, Ultramarine, Van Dyck Brown, and White.

NUMBER	EACH	6/EA
A22652-1449	\$155.88	\$140.29



Sargent Art® Colored Pencil Sets

Ideal for artists and illustrators of all ages — at an economical price! High-quality pigments provide consistent color coverage and smooth color laydown. Use these pencils for drawing, illustration, and special effect

blending. Their color-coordinated cases are made of premium wood for durability and easy sharpening. Pre-sharpened 7" long pencils have 3.3 mm leads.

NUMBER	SET	EACH	6/EA
A22046-1012	12 Colors	\$2.19	\$1.98
A22046-1024	24 Colors	5.22	4.69
A22046-1036	36 Colors	7.54	6.68
A22046-1050	50 Colors	8.58	7.73



Prang® Colored Pencils

These colored pencils are encased in real wood, pre-sharpened, and ready to use, with smooth, 3.3 mm cores for vivid, blendable color laydown. Manufactured using only the finest materials, these high-quality pencils have the color names prominently displayed on each one.

NUMBER	SET	EACH	12/EA
A22088-1012	12 Colors	\$3.33	\$2.99
A22088-1024	24 Colors	6.54	5.89
A22088-1036	36 Colors	10.72	9.65
A22088-1048	48 Colors	13.19	11.87



Pentel Arts® Color Pencil Sets

These colored pencils feature clear, brilliant colors that apply smoothly and blend easily for subtle shades, tints, and color mixtures. Strong, break-resistant cores are glued to the wood casings.

NUMBER	SET	EACH	12/EA
A22418-1012	12 Colors	\$4.39	\$3.95
A22418-1024	24 Colors	10.26	9.24
A22418-1036	36 Colors	14.94	13.44



Derwent® Lightfast Colored Pencil Sets

Guaranteed to last up to 100 years under museum conditions, these lightfast colored pencils are designed to combat the effects of UVA light. Every professional-quality, oil-infused pencil in the 72-color range has a smooth, creamy core that lays down dense, opaque color and mixes well with other media to create new colors.

NUMBER	SET	EACH	6/EA
A67924-1129	12 Colors	\$48.84	\$43.96
A67924-1249	24 Colors	97.63	87.87
A67924-1369	36 Colors	145.99	131.39
A67924-1729	72 Colors	228.77	205.89
A67924-1001	100 Colors	399.00	359.00



Derwent® ProColour Colored Pencil Sets

These highly pigmented, lightfast colored pencils have a smooth formulation and laydown, combined with a strong 4 mm core that sharpens to a fine point for creating detailed layers. Ideal for blending, layering, cross-hatching, and other techniques, ProColour pencils also have a clean, no-dust formula. For individual pencils and set contents, visit DickBlick.com.

NUMBER	SET	EACH	6/EA
A22478-1129	12 Colors	\$32.10	\$28.88
A22478-1249	24 Colors	59.99	53.99
A22478-1369	36 Colors	94.99	85.48
A22478-1729	72 Colors	190.75	171.67



Sargent Art® Colored Pencil Classroom Packs

These 7" long, pre-sharpened pencils have a thick 3.3 mm core for excellent color laydown. Offered at an economical price, the 250-count classroom pack offers 25 each of 10 colors, including Black, Blue, Brown, Dark Green, Light Green, Orange, Pink, Red, Violet, and Yellow. The 120-count classroom pack includes two or three each of 56 different colors. For complete set contents, visit DickBlick.com.

NUMBER	DESCRIPTION	EACH	6/EA
A22046-1120	120-ct	\$25.67	\$23.10
A22046-1250	250-ct	48.47	43.63



Prang® Colored Pencil Classroom Master Pack

An economical option for classrooms and large groups, this box of 288 colored pencils includes 24 each of 12 colors and comes in a sturdy, reusable storage box with a handle.

NUMBER	EACH	4/EA
A22088-1288	\$78.74	\$70.87



Fantasia Colored Pencils

A great choice for the beginning colored pencil artist, these sets contain a wonderful selection of artist-quality pencils with thick, blendable leads, each packed in a reusable metal tin. For even more creative fun, try combining them with watercolors or using them on surfaces such as wood, fabric, or board. Classroom pack includes 24 each of 12 colors.

NUMBER	SET	EACH	4/EA
A22015-1009	12 Colors	\$10.85	\$9.77
A22015-2009	24 Colors	16.71	15.04
A22015-3009	36 Colors	25.06	22.55
A22015-6009	48 Colors	33.41	30.07
A22015-5009	Classroom Pack of 288	117.19	105.50



Cretacolor® Mega Colored Pencils

Designed for artists of all skill levels, these artist-quality colored pencils come in a range of 36 highly pigmented colors. Their 6.4 mm cores make broad strokes in your drawings, and the extra-large casings sit comfortably in the hand. Colors can be assorted for quantity pricing.

NUMBER	COLOR	EACH	12/EA
A22691-2020	Black	\$2.46	\$2.17
A22691-5390	Blue Violet	2.46	2.17
A22691-4670	Cadmium Citron	2.46	2.17
A22691-3720	Carmine Extra Fine	2.46	2.17
A22691-8280	Chestnut Brown	2.46	2.17
A22691-4150	Chromium Yellow	2.46	2.17
A22691-3740	Cyclamen	2.46	2.17
A22691-2530	Dark Grey	2.46	2.17
A22691-5210	Delft Blue	2.46	2.17
A22691-7050	Emerald	2.46	2.17
A22691-3400	English Red	2.46	2.17
A22691-7240	Grass Green	2.46	2.17
A22691-5200	Indigo	2.46	2.17
A22691-1040	Ivory	2.46	2.17
A22691-7150	Leaf Green	2.46	2.17
A22691-5020	Light Blue	2.46	2.17
A22691-2510	Light Grey	2.46	2.17
A22691-3160	Madder Carmine	2.46	2.17
A22691-3040	Magenta	2.46	2.17
A22691-7520	Moss Green Dark	2.46	2.17
A22691-7920	Moss Green Light	2.46	2.17
A22691-4140	Naples Yellow	2.46	2.17
A22691-8380	Ochre Dark	2.46	2.17
A22691-8210	Ochre Light	2.46	2.17
A22691-3500	Old Rose Light	2.46	2.17
A22691-7940	Olive Green Dark	2.46	2.17
A22691-4510	Orange	2.46	2.17
A22691-3750	Permanent Red Dark	2.46	2.17
A22691-3830	Permanent Red Light	2.46	2.17
A22691-1170	Permanent White	2.46	2.17
A22691-5220	Prussian Blue	2.46	2.17
A22691-8230	Tan Light	2.46	2.17
A22691-5400	Turquoise Dark	2.46	2.17
A22691-5230	Ultramarine	2.46	2.17
A22691-8530	Umber	2.46	2.17
A22691-3760	Violet	2.46	2.17

Pencil Grip™ Two-Hole Sharpener Classroom Pack

Ideal for sharpening both standard and jumbo wood-cased pencils and colored pencils, the Pencil Grip Two-Hole Pencil Sharpener features all-metal sharpeners, a removable shavings container, and a protective lid. The blades are attached at three points for greater sharpening precision, and a special cutout makes removal of broken leads quick and easy. Convenient classroom pack includes 20 sharpeners, five each of Blue, Green, Red, and Yellow.

NUMBER	EACH	6/EA
A21486-1020	\$41.99	\$37.82



Maped® Color'Peps Triangular Colored Pencil Sets

These brightly colored pencils with ergonomic triangular barrels make it easy for students to grip. The soft, resilient 2.9 mm cores are pigment-based, and the pre-sharpened pencils can be sharpened in any traditional pencil sharpener. The school pack of 240 includes 20 each of 12 colors, plus five sharpeners, in a convenient storage box.

NUMBER	SET	EACH	12/EA
A22467-1129	12 Colors	\$2.91	\$2.62
A22467-1249	24 Colors	5.83	5.25
A22467-1369	36 Colors	8.75	7.88
A22467-1489	48 Colors	11.68	10.51
A22467-2409	240-ct School Pack	58.29	52.46



Prang® Duo-Color™ Colored Pencils

Two colors in every pencil! Two rich, bright colors are carefully paired within the same pencil so it's easy to switch from Silver to Gold, Magenta to Violet, or Green to Blue with a quick flip. Pre-sharpened pencils feature 3 mm cores and soft laydown for hours of smooth, easy coloring.

NUMBER	SET	EACH	6/EA
A22483-1012	Set of 6	\$3.03	\$2.73
A22483-1024	Set of 12	6.04	5.44
A22483-1036	Set of 18	8.45	7.60



Caran D'Ache® Pablo Colored Pencils

These superior-quality artists' pencils work well on paper, wood, or photographs. Creamy, soft, water-resistant 3.7 mm leads offer exceptional covering power and superb lightfastness. For shading, mixed media, and graded applications, combine them with Supracolor Aquarelle and Neocolor crayons. Packaged in sturdy metal boxes.

NUMBER	SET	EACH	6/EA
A20581-1012	12 Colors	\$31.83	\$28.65
A20581-1018	18 Colors	47.71	42.94
A20581-1030	30 Colors	88.41	79.57
A20581-1040	40 Colors	117.83	106.05
A20581-1080	80 Colors	235.11	211.60
A20581-0129	120 Colors	360.00	324.00



Krylon® Gallery Series™ Fine Art Fixatif

Protect your artwork without dissolving whites and lights with this invisible spray that provides both workable and final protection. Its powerful combination of Hindered Amine Light Stabilizer (HALS) and an exclusive UV Absorber (UVA) protects pastel, pencil, charcoal, and chalk work from UV light, smudging, smearing, dusting, fading, yellowing, cracking, moisture, and more. 11 oz (325 ml) can.

NUMBER	EACH	6/EA
A21731-1011	\$15.44	\$13.92



Grumbacher® Final Fixative

A fixative for charcoal, pastels, and pencil work, for use on paper, photographs, printed materials, and ceramics. Colorless, flexible, and non-yellowing, Final Fixative can be reworked when dry. Fast-drying. Available in gloss or matte finish.

NUMBER	DESCRIPTION	EACH	12/EA
A21724-2011	11.75 oz (347 ml) Matte	\$17.11	\$15.40
A21724-1011	11.75 oz (347 ml) Gloss	17.11	15.40
A21724-1004	4.75 oz (140 ml) Gloss	9.44	8.52





Global Canvas Pencil Cases

Handcrafted from a finely woven 16 oz canvas, these versatile pencil cases are perfect for travel or storage. Each elastic loop holds up to four pencils or two markers, and the three-sided zipper closure keeps everything secure. (Pencils not included.)

24-ct

NUMBER	COLOR	EACH	6/EA
A22744-2024	Black	\$17.42	\$15.68
A22744-5914	Denim	17.42	15.68
A22744-3124	Rose	17.42	15.68
A22744-5324	Steel Blue	17.42	15.68
A22744-8924	Wheat	17.42	15.68

48-ct

NUMBER	COLOR	EACH	6/EA
A22744-2048	Black	\$23.96	\$21.56
A22744-5918	Denim	23.96	21.56
A22744-3148	Rose	23.96	21.56
A22744-5348	Steel Blue	23.96	21.56
A22744-8948	Wheat	23.96	21.56

120-ct

NUMBER	COLOR	EACH	6/EA
A22744-2120	Black	\$39.21	\$35.29
A22744-3170	Rose	39.21	35.29
A22744-5380	Steel Blue	39.21	35.29



Global Classic Leather Pencil Cases

The perfect solution for organizing, storing, and transporting most types of pencils and pens. Cases feature contrasting stitching, flocked interiors, and a heavy-duty metal zipper that snaps to the spine for secure closure. (Pencils not included.)

Black

NUMBER	DESCRIPTION	EACH	6/EA
A22996-2025	24-Pencil Capacity	\$26.95	\$24.25
A22996-1048	48-Pencil Capacity	32.72	29.45
A22996-2072	72-Pencil Capacity	42.19	37.97
A22996-2096	96-Pencil Capacity	46.91	42.22
A22996-2120	120-Pencil Capacity	51.36	46.23

Brown

NUMBER	DESCRIPTION	EACH	6/EA
A22996-8048	48-Pencil Capacity	\$32.72	\$29.45
A22996-8072	72-Pencil Capacity	42.19	37.97
A22996-8096	96-Pencil Capacity	46.91	42.22
A22996-8120	120-Pencil Capacity	51.36	46.23



Tran Deluxe Pencil Cases

These great little storage cases make transporting your pencils easier than ever. The hard case is covered in black 600 Denier nylon, with a full zipper closure and wrist strap. Elastic pockets hold from 24 to 120 colored pencils and other accessories.

NUMBER	DESCRIPTION	EACH	3/EA
A22842-2051	24-Pencil Case	\$20.45	\$18.40
A22842-2052	48-Pencil Case	25.92	23.33
A22842-2053	72-Pencil Case	28.55	25.69
A22842-2054	96-Pencil Case	34.03	30.62
A22842-2055	120-Pencil Case	39.47	35.53



Colorless Blender

Brush and Pencil Colored Pencil Powder Blenders

Colorless Blender — Blend, erase, correct, or adjust your colored pencil drawings with this archival dry lubricant. It eliminates the need for solvents when blending, and works well on sanded papers or toothy gessoes. It performs best with oil-based colored pencils but can be used with wax-based pencils when pretreating the surface for subsequent layers. Secure with Textured or Final Fixative. 14 g jar with sifter.

NUMBER	EACH	6/EA
A04843-1001	\$8.84	\$7.91

Titanium White — Apply to toothy surfaces for complete coverage. Easy to lift with mounting putty, and also easy to secure to the surface with Advanced Textured Fixative or Final Fixative. Create bright highlights (such as eyes or cat whiskers) by mixing a small amount with a few drops of Touch-Up Texture, then apply with a fine brush. Highlights can be worked over with colored pencil when dry. 14 g jar with sifter.

NUMBER	EACH	6/EA
A04843-1020	\$8.84	\$7.91



Caran D'Ache Metal Tins

Keep your sketching materials safe and in one place with these handy empty metal tins from Caran d'Ache. Designed to accommodate a variety of items from the Caran d'Ache Graphite line, the hinged tins also make a great gift — simply fill them with a selection of Caran d'Ache sketching materials.

NUMBER	SIZE	EACH	6/EA
A22702-1001	7" x 2-1/4" x 1"	\$6.29	\$5.66
A22702-1002	7" x 2-1/4" x 1-1/2"	12.19	10.97

Brush and Pencil Advanced Colored Pencil Fixatives

Two fixatives, two purposes! Both of these advanced fixatives are non-toxic, non-yellowing, non-darkening, acid-free, and odor-free. Both dry and harden within minutes.

Final Fixative — Provides long-lasting protection for colored pencil drawings. 9 oz (266 ml).

NUMBER	DESCRIPTION	EACH	6/EA
A21733-1001	Final	\$18.47	\$16.62

Textured Fixative — Enables virtually unlimited layering by restoring tooth to the painting surface, with minimal effect on established values or colors. Isolates previous layers and makes them resistant to subsequent application of water, alcohol, or odorless mineral spirits. Provides ability to apply chromatic colors onto black/dark surfaces without white underpainting. Allows development of the form from "dark to light" and "light to dark." 9 oz (266 ml).

NUMBER	DESCRIPTION	EACH	6/EA
A21733-1002	Textured	\$18.47	\$16.62



Faber-Castell Polychromos Colored Pencil Sets

Polychromos Colored Pencils have premium California cedar wood barrels with Secureall bonding to help prevent breakage. The highest-quality pigments offer unsurpassed lightfastness. Colors lay down smoothly and are easily blended for layered effects, highlights, and transitions. 3.8 mm leads are break-resistant, water-resistant, and smudgeproof.

NUMBER	SET	EACH	12/EA
A20561-0129	12 Color Tin	\$28.03	\$25.23
A20561-0249	24 Color Tin	56.12	50.51
A20561-0369	36 Color Tin	84.14	75.73
A20561-0609	60 Color Tin	133.03	119.73
A20561-1209	120 Color Tin	269.60	242.64



Westcott iPoint Halo Colored Pencil Sharpener

Quickly sharpen your colored pencils without damaging them! Equipped with non-stick titanium bonded blades that stay sharp 5X longer than conventional blades, the iPoint Halo Electric Colored Pencil Sharpener has an auto shut-off feature that prevents oversharpener when the perfect point has been achieved. Its vertical design has a smaller footprint on desks and work surfaces, and a clear EZ View shavings reservoir tells you when it's full. Black.

NUMBER	EACH	6/EA
A04850-2410	\$64.03	\$57.63



Derwent Coloursoft Pencil Sets

These soft, smooth, velvety pencils can be mixed and blended to create an infinite spectrum of rich, vibrant colors. They're ideal for a wide range of drawing styles, from bold, contemporary still lifes and portraiture to finely detailed work such as fashion illustration, animal portraiture, and landscapes. Their unique formulation is highly blendable and glides smoothly over a wide variety of drawing surfaces. Acid-free and tested for lightfastness.

NUMBER	SET	EACH	12/EA
A22064-2006	6 Skintones	\$14.31	\$12.88
A22064-1012	12 Colors	25.69	23.12
A22064-1024	24 Colors	50.82	45.73
A22064-1036	36 Colors	76.41	68.77
A22064-1072	72 Colors	153.15	137.84
A22064-0729	Wood Box, 72 Colors	249.63	224.68



Derwent Studio Pencil Sets

Each set comes in a handy hinge-lid metal box. The wood box set of 72 pencils features a handsome ebony finish.

NUMBER	SET	EACH	6/EA
A20506-1009	12 Colors	\$23.56	\$21.92
A20506-1109	24 Colors	47.31	43.87
A20506-1209	36 Colors	70.99	65.81
A20506-1309	72 Colors	141.92	131.55
A20506-1409	72-Color Wood Box Set	250.94	225.84



Lyra Rembrandt Polycolor Premium Oil-Based Colored Pencil Sets

Offering the ultimate control on paper, these premium oil-based colored pencils lay down smoothly with no wax buildup. They're easily blended and overlaid for limitless hues and formulated with the highest standards of lightfastness. Housed in metal boxes.

NUMBER	SET	EACH	6/EA
A22049-0129	12 Colors	\$20.99	\$18.89
A22049-2129	12 Grays	20.99	18.89
A22049-0249	24 Colors	40.96	36.81
A22049-0369	36 Colors	66.90	60.21
A22049-0729	72 Colors	132.42	119.18

Caran D'Ache Luminance Colored Pencil Sets

These pencils combine the smoothness of a permanent lead with excellent lightfastness. Every shade has been formulated using finely ground pigments chosen for their purity, intensity, and resistance to UV rays. Strong coverage and mixing capacity allow for intense applications, blending, and burnishing, while extreme softness enables subtle blending and gradations. Cases are made of California cedar. Conforms to ASTM D-6901.

NUMBER	SET	EACH	6/EA
A22084-1129	12 Colors	\$54.82	\$49.34
A22084-1209	20 Colors	91.99	82.79
A22084-1409	40 Colors	170.39	153.35
A22084-1769	76 Colors	311.00	279.90

Lyra Splendor Colorless Blender

Blend pencils together with this colorless Polycolor pencil that moves color around to fill in and polish drawings. It works well with most colored pencils and best with oil-based or liquid wax pencils.

NUMBER	EACH	12/EA	24/EA
A20592-1000	\$1.93	\$1.74	\$1.65

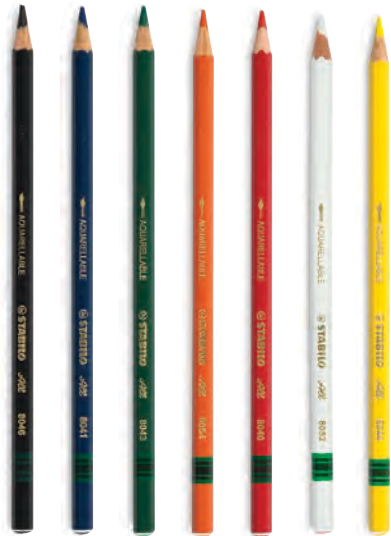

Stabilo All Colored Marking Pencils

These are not artists' colored pencils for drawing and sketching, but rather colored marking pencils with soft, waxy cores that mark on virtually any surface. Use them for writing in color on paper, plastic, film, mylar, and more. They're also useful for correcting drafts and proofs, or for marking layouts. Pre-sharpened. Colors can be assorted for quantity pricing.

NUMBER	COLOR	EACH	12/EA
A20408-2001	Black	\$1.86	\$1.67
A20408-5001	Blue	1.86	1.67
A20408-7001	Green	1.86	1.67
A20408-4501	Orange	1.86	1.67
A20408-3001	Red	1.86	1.67
A20408-1001	White	1.86	1.67
A20408-4001	Yellow	1.86	1.67



Pencil Grips

Designed by physicians to help stop writing fatigue, these colorful, soft rubber grips can also help small fingers hold tight. Fit over pencils, pens, crayons, and brushes. Latex-free and phthalate-free. Assorted colors.

NUMBER	DESCRIPTION	EACH	12/EA	24/EA
A22954-1012	12 pk	\$27.31	\$24.58	\$23.36
A22954-1000	Single	2.31	2.08	1.97

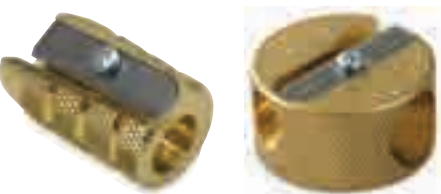

Mobius & Ruppert Brass Grenade Pencil Sharpeners

Virtually unbreakable, these ergonomic brass pencil sharpeners are a favorite of design professionals and artists. Choose single or double-hole design. Made in Germany.

NUMBER	DESCRIPTION	EACH	12/EA
A21413-1040	Single Hole	\$6.54	\$5.89
A21413-1020	Double Hole	10.84	9.74



Holbein Colored Pencils

This range of superbly pigmented, professional-quality pencils feature soft, oil-based 3.8 mm cores. Ideal for blending, layering, and creating subtle color gradations, they provide a smooth application and ideal for practicing artists and students of all levels. Round, sturdy barrels are painted to match the core. Available in 150 colors. For set contents, visit DickBlick.com.

NUMBER	SET	EACH	6/EA
A82520-1009	12 Basic Colors	\$43.43	\$39.09
A82520-1019	12 Design Colors	43.43	39.09
A82520-1029	12 Pastel Colors	43.43	39.09
A82520-1039	24 Colors	86.59	77.93
A82520-1049	36 Colors	129.49	116.53



Derwent Academy Colored Pencil Sets

With high-quality pigments in a natural wood casing, Derwent Academy Colored Pencil Sets feature vivid shades that blend well and transfer color to paper beautifully. For set contents, visit DickBlick.com.

NUMBER	SET	EACH	6/EA
A22417-1012	12 Colors	\$12.64	\$11.38
A22417-1024	24 Colors	26.81	24.13



Tombow Irojiten Color Pencil Sets

"Irojiten" is the Japanese expression for "color encyclopedia." Available in 90 unique, natural colors, these beautifully crafted, artist-grade pencils possess qualities that have made them an all-time classic in Japan. Irojiten Color Pencils have an elegant enamel finish and a rich, creamy texture that allows for smooth, even blending and easy layering with no waxy buildup. For set contents, visit DickBlick.com.

NUMBER	SET	EACH	6/EA
A22406-2129	12 Tranquil Colors	\$30.85	\$27.76
A22406-1129	12 Vivid Colors	30.85	27.76
A22406-1030	30 Rainforest Colors	67.99	61.18
A22406-3030	30 Seascape Colors	67.99	61.18
A22406-2030	30 Woodland Colors	67.99	61.18



Koh-I-Noor Woodless Colored Pencils

These high-density woodless pencils are ideal for sketching and drawing. Smooth color laydown and a weighty, lacquered body make them a unique addition to your colored pencil collection. Use a standard sharpener. Colors can be assorted for quantity pricing.

NUMBER	SET	EACH	6/EA
A22027-1001	2-pk (Gold and Silver)	\$8.42	\$7.57
A22027-0129	12 Colors	9.70	8.73
A22027-0249	24 Colors	19.20	18.11

NUMBER	COLOR	EACH	12/EA
A22027-2020	Black	\$1.14	\$1.03
A22027-8000	Brown	1.14	1.03
A22027-8040	Burnt Sienna	1.14	1.03
A22027-3150	Carmine	1.14	1.03
A22027-5030	Dark Blue	1.14	1.03
A22027-7030	Dark Green	1.14	1.03
A22027-6610	Dark Violet	1.14	1.03
A22027-4030	Dark Yellow	1.14	1.03
A22027-7120	Hooker's Green	1.14	1.03
A22027-5020	Light Blue	1.14	1.03
A22027-2510	Light Gray	1.14	1.03
A22027-7010	Light Green	1.14	1.03
A22027-8420	Light Ochre	1.14	1.03
A22027-3280	Light Vermilion	1.14	1.03
A22027-6530	Light Violet	1.14	1.03
A22027-4010	Light Yellow	1.14	1.03
A22027-8080	Natural Sepia	1.14	1.03
A22027-4510	Orange	1.14	1.03
A22027-5190	Paris Blue	1.14	1.03
A22027-3060	Pink	1.14	1.03
A22027-7090	Sap Green	1.14	1.03
A22027-3410	Scarlet Lake	1.14	1.03
A22027-5070	Sky Blue	1.14	1.03
A22027-1020	White	1.14	1.03



Koh-I-Noor Polycolor Colored Pencil Sets

Polycolor premium oil-based drawing pencils cased in California Cedar offer the ultimate control on paper, laying down smoothly with no wax buildup. Use them for drawing, illustrating, and coloring. Formulated to the highest standards of lightfastness, they're easily blended and overlaid to create an unlimited range of hues.

NUMBER	SET	EACH	6/EA
A22026-0129	12 Colors	\$20.46	\$18.41
A22026-0249	24 Colors	37.89	34.10
A22026-0369	36 Colors	61.09	54.98
A22026-0729	72 Colors	119.97	107.98

NUMBER	COLOR
A22063-7171	Apple Green
A22063-5911	Azure Blue
A22063-8141	Beige
A22063-7921	Bice Green
A22063-2021	Black
A22063-5101	Blue Green
A22063-5391	Blue Violet
A22063-3711	Blush Pink
A22063-3721	Bordeaux-Red
A22063-8001	Brown
A22063-8271	Burnt Ochre
A22063-8051	Burnt Umber
A22063-4531	Cadmium Orange
A22063-4261	Canary Yellow
A22063-3161	Carmine
A22063-3151	Carmine Red
A22063-3451	Cherry Red
A22063-5181	Cobalt Blue
A22063-5381	Cobalt Dark
A22063-2811	Cold Grey
A22063-2801	Cool Grey 1
A22063-2803	Cool Grey 3
A22063-2805	Cool Grey 5
A22063-2806	Cool Grey 6
A22063-2808	Cool Grey 8
A22063-2809	Cool Grey 9
A22063-1101	Cream
A22063-3731	Crimson Lake
A22063-5031	Dark Blue
A22063-8031	Dark Brown
A22063-7251	Dark Grass Green
A22063-7031	Dark Green
A22063-2531	Dark Grey
A22063-8211	Dark Ochre
A22063-7841	Dark Olive Green
A22063-4731	Dark Orange
A22063-4031	Dark Yellow
A22063-5211	Delft Blue
A22063-7051	Emerald Green
A22063-9011	Gold
A22063-9031	Gold Ochre
A22063-7241	Grass Green
A22063-2501	Grey
A22063-5561	Ice Blue
A22063-3251	Indian Red
A22063-5201	Indigo Blue
A22063-5021	Light Blue
A22063-8011	Light Brown
A22063-7011	Light Green
A22063-2511	Light Grey
A22063-4501	Light Orange
A22063-3681	Light Peach
A22063-6531	Light Violet
A22063-4011	Light Yellow
A22063-7331	May Green
A22063-5121	Medium Grey
A22063-5931	Mountain Blue
A22063-4141	Naples Yellow
A22063-7861	Olive Green Light
A22063-4511	Orange
A22063-4831	Orange Yellow
A22063-7551	Pea Green
A22063-3351	Peach
A22063-5781	Permanent Blue
A22063-6911	Permanent Violet
A22063-5161	Phthalo Blue
A22063-3061	Pink
A22063-3641	Pink Rose
A22063-5221	Prussian Blue
A22063-8071	Raw Umber
A22063-6721	Red Violet
A22063-3511	Salmon Pink
A22063-7091	Sap Green
A22063-3081	Scarlet Red
A22063-9331	Silver
A22063-5071	Sky Blue
A22063-2601	Slate Grey
A22063-5861	Steel Grey
A22063-3761	Terra Cotta
A22063-5301	Ultramarine Light
A22063-3281	Vermilion
A22063-6511	Violet
A22063-2321	Warm Grey 1
A22063-2322	Warm Grey 2
A22063-2323	Warm Grey 3
A22063-2325	Warm Grey 5
A22063-2326	Warm Grey 6
A22063-2329	Warm Grey 8
A22063-1021	White
A22063-6741	Windsor Violet
A22063-4001	Yellow

BLICK studio artists' colored pencils

Blick Studio Artists' Colored Pencils

Ideal for drawing, illustrating, and coloring, these highly pigmented, richly colored pencils feature brilliantly balanced shades for superior blending. Their fade-resistant 3.8 mm colored leads are encased in lacquered round California cedar casings. For easy identification, the exterior of each pencil is colored to match the core and the color name is printed on both ends. Pencils are pre-sharpened. Colors can be assorted for quantity pricing.

Blick Studio Artists' Colored Pencil Sets

NUMBER	SET	EACH	12/EA	50/EA
A22063-0129	12 Colors	\$14.82	\$13.34	\$12.67
A22063-2129	12 Grey	14.82	13.34	12.67
A22063-0249	24 Colors	28.79	25.91	24.61
A22063-2249	24 Landscape	28.79	25.91	24.61
A22063-1249	24 Portrait	28.79	25.91	24.61
A22063-0369	36 Colors	39.99	35.99	34.19
A22063-0489	48 Colors	53.59	48.23	45.82
A22063-0729	72 Colors	76.79	69.11	65.65
A22063-1729	72 Colors Wood Box	133.29	119.95	113.95

Blick Studio Colorless Blender

A colorless blender pencil to use with Blick Studio Artists' Pencils. Use to lighten colors, blend overlapping colors, and soften hard edges without cloudy buildup or adding additional color. Natural wood barrel has a clear polyurethane coating.

NUMBER	EACH	12/EA
A22063-0000	\$1.40	\$1.26



EACH	12/EA
\$1.40	\$1.26

Helpful for individuals with special needs.



Prismacolor® Premier Verithin® Pencils

Brilliantly colored and can be sharpened to a very fine point. The firm, insoluble pigments lay down smoothly. Each hexagonal wood case is color-coded.

Colors can be assorted for quantity pricing.

NUMBER	SET	EACH	12/EA
A20509-1209	12 Colors	\$11.15	\$10.03
A20509-2409	24 Colors	21.18	19.06
A20509-0309	36 Colors	33.35	29.99

Individual Verithin Pencils

NUMBER	COLOR
A20509-7011	Apple Green
A20509-7841	Aquamarine
A20509-2001	Black
A20509-4261	Canary Yellow
A20509-2531	Cool Grey 70%
A20509-3151	Crimson Red
A20509-6001	Dahlia Purple
A20509-8121	Dark Brown
A20509-8031	Dark Umber
A20509-3051	Deco Pink
A20509-4051	Gold
A20509-8401	Goldenrod
A20509-7241	Grass Green
A20509-5201	Indigo Blue
A20509-4061	Lemon Yellow
A20509-5911	Light Cerulean Blue
A20509-3351	Light Peach
A20509-3041	Magenta
A20509-5531	Non-Photo Blue
A20509-7071	Olive Green
A20509-4501	Orange
A20509-6041	Parma Violet
A20509-5071	Peacock Blue
A20509-7001	Peacock Green
A20509-3081	Poppy Red
A20509-5811	Red and Blue
A20509-9300	Silver
A20509-8171	Terra Cotta
A20509-5281	True Blue
A20509-3721	Tuscan Red
A20509-5231	Ultramarine
A20509-6501	Violet
A20509-2511	Warm Grey 20%
A20509-1001	White

Prismacolor® Premier Manga Pencil Set

This set of 23 Prismacolor colored pencils includes shades selected especially for manga drawing. The set includes 18 Prismacolor Premier colored pencils and five Verithin colored pencils.

NUMBER	EACH	3/EA
A22403-1023	\$32.26	\$29.03

Prismacolor® Premier Pencil Sharpener

One sharpener, two uses! This versatile sharpener features two sharpeners, one for sharpening colored pencils and one for graphite and Verithin pencils. Transparent housing makes it easy to see shavings while the sliding cover keeps them contained.

NUMBER	EACH	12/EA
A21422-1002	\$6.56	\$5.90



Bostitch® Super Pro Glow™ Commercial Electric Pencil Sharpener

Made for demanding environments, the Super Pro Glow sharpener features XHC(2)™ dual-cutter technology for 50% faster sharpening of graphite and colored pencils. Other premium features include SharpStop™ technology to prevent over-sharpening, a SharpGlow™ illumination dial, and a MagnaSafe™ tamper-proof safety switch that shuts down the motor when the tray is removed. What's more, an exclusive tool-free replaceable cutter system guarantees a lifetime of use. Antimicrobial protection is ideal for the classroom. Seven-year limited warranty.

NUMBER	DESCRIPTION	EACH	3/EA
A21483-9331	Sharpener	\$136.89	\$123.20
A21483-1001	Replacement Cutter Cartridge	17.41	15.67



Prismacolor® Premier Mixed Media Set

From simple sketches to complex creations, the Prismacolor Mixed Media Set has you covered. It contains a variety of artist-quality colored pencils, including 48 Premier colored pencils, 12 Verithin colored pencils, six Art Stix woodless colored pencils, 12 watercolor pencils, and a sharpener.

NUMBER	EACH	12/EA
A22411-1079	\$112.12	\$103.83



Liqui-Mark® Neon Colored Pencil Set

Add splashes of neon to your drawings with these colored pencils in a variety of bright, vivid colors. The hard, school-quality cores are long-lasting. The set of 10 pencils includes Orange Heat, Yellow Spark, Vivid Violet, Sunray, Passion Peach, Lightening Lime, Flashbulb Blue, Green Glare, Fuchsia Flare, and Powerful Pink.

NUMBER	EACH	12/EA
A22460-1010	\$3.40	\$3.07



Individual Pencils

NUMBER	COLOR
A20508-7171	Apple Green
A20508-5361	Aquamarine
A20508-7111	Artichoke
A20508-8141	Beige
A20508-8241	Beige Sienna
A20508-2001	Black
A20508-3718	Black Cherry
A20508-6141	Black Grape
A20508-3661	Black Raspberry
A20508-5941	Blue Lake
A20508-5311	Blue Slate
A20508-5390	Blue Violet Lake
A20508-3711	Blush Pink
A20508-8151	Bronze
A20508-8271	Burnt Ochre
A20508-4531	Cadmium Orange
A20508-4261	Canary Yellow
A20508-5161	Caribbean Sea
A20508-3151	Carmine Red
A20508-7481	Celadon Green
A20508-5171	Cerulean Blue
A20508-7631	Chartreuse
A20508-8281	Chestnut
A20508-5151	China Blue
A20508-8360	Chocolate
A20508-3651	Clay Rose
A20508-5912	Cloud Blue
A20508-5181	Cobalt Blue
A20508-5371	Cobalt Turquoise
A20508-2811	Cool Gray 10%
A20508-2821	Cool Gray 20%
A20508-2831	Cool Gray 30%
A20508-5009	Cool Gray 50%
A20508-2871	Cool Gray 70%
A20508-2891	Cool Gray 90%
A20508-5911	Copenhagen Blue
A20508-1101	Cream
A20508-3710	Crimson Lake
A20508-3161	Crimson Red
A20508-6411	Dahlia Purple
A20508-8031	Dark Brown
A20508-7031	Dark Green
A20508-6011	Dark Purple
A20508-8381	Dark Umber
A20508-3671	Deco Peach
A20508-3691	Deco Pink
A20508-4741	Deco Yellow
A20508-5921	Denim Blue
A20508-6021	Dioxazine Purple
A20508-1231	Eggshell
A20508-5811	Electric Blue
A20508-8181	Espresso
A20508-2911	French Gray 10%
A20508-2921	French Gray 20%
A20508-2931	French Gray 30%
A20508-2951	French Gray 50%
A20508-2609	French Gray 70%
A20508-2991	French Gray 90%
A20508-8111	Ginger Root
A20508-4911	Goldenrod
A20508-7241	Grass Green
A20508-7681	Gray Green
A20508-6151	Grayed Lavender
A20508-7731	Green Ochre
A20508-8911	Henna
A20508-3291	Hot Pink
A20508-6412	Imperial Violet
A20508-5341	Indanthrone Blue
A20508-5201	Indigo Blue
A20508-7221	Jade Green
A20508-4732	Jasmine
A20508-7151	Kelly Green
A20508-7371	Kelp Green
A20508-6041	Lavender
A20508-4061	Lemon Yellow

Individual Pencils

NUMBER	COLOR
A20508-5831	Light Aqua
A20508-5821	Light Cerulean Blue
A20508-7011	Light Green
A20508-3681	Light Peach
A20508-8431	Light Umber
A20508-6031	Lilac
A20508-7911	Lime Peel
A20508-3041	Magenta
A20508-3714	Mahogany Red
A20508-7811	Marine Green
A20508-5711	Mediterranean Blue
A20508-4761	Metallic Gold
A20508-9320	Metallic Silver
A20508-4751	Mineral Orange
A20508-7521	Moss Green
A20508-3591	Mulberry
A20508-5111	Muted Turquoise
A20508-1251	Nectar
A20508-4671	Neon Orange
A20508-3601	Neon Pink
A20508-4851	Neon Yellow
A20508-5531	Non-Photo Blue
A20508-7071	Olive Green
A20508-4501	Orange
A20508-6461	Pale Sage
A20508-3761	Pale Vermilion
A20508-6161	Parma Violet
A20508-7781	Parrot Green
A20508-3351	Peach
A20508-3341	Peach Beige
A20508-5211	Peacock Blue
A20508-7531	Peacock Green
A20508-5771	Periwinkle
A20508-3731	Permanent Red
A20508-3051	Pink
A20508-3649	Pink Rose
A20508-1221	Pomegranate
A20508-3611	Poppy Red
A20508-5901	Powder Blue
A20508-3771	Process Red
A20508-7581	Prussian Green
A20508-4621	Pumpkin Orange
A20508-1621	Putty Beige
A20508-3361	Raspberry
A20508-3631	Rosy Beige
A20508-3511	Salmon Pink
A20508-8510	Sand
A20508-8541	Sandbar Brown
A20508-7091	Sap Green Light
A20508-3411	Scarlet Lake
A20508-3781	Seashell Pink
A20508-8081	Sepia
A20508-8121	Sienna Brown
A20508-5071	Sky Blue Light
A20508-2611	Slate Gray
A20508-4801	Spanish Orange
A20508-7331	Spring Green
A20508-4541	Sunburst Yellow
A20508-8171	Terra Cotta
A20508-5281	True Blue
A20508-7421	True Green
A20508-3721	Tuscan Red
A20508-5231	Ultramarine
A20508-6501	Violet
A20508-6601	Violet Blue
A20508-2711	Warm Gray 10%
A20508-2721	Warm Gray 20%
A20508-2731	Warm Gray 30%
A20508-2751	Warm Gray 50%
A20508-2771	Warm Gray 70%
A20508-2791	Warm Gray 90%
A20508-1001	White
A20508-4311	Yellow Chartreuse
A20508-4041	Yellow Ochre
A20508-4841	Yellowed Orange

Prismacolor® Premier Colorless Blender

Special formula designed to soften hard edges; lighten or blend colored pencils. Use for a smooth, blended look. Can be layered on top of any color without cloudy buildup. Colors and colorless blender can be assorted for quantity pricing.

NUMBER	EACH	12/EA
A20508-1010	\$1.77	\$1.59

PRISMACOLOR®



Prismacolor® Premier Colored Pencils

Thick, soft cores are made from brilliant, light-resistant pigments. Colors are easily blended, slow to wear, and waterproof. Each round wood case is laquered to match the lead. Sets are packaged in collectible metal boxes. Colors can be assorted for quantity pricing.

Colors can be assorted for quantity pricing.

NUMBER	SET	EACH	12/EA	50/EA
A20508-1029	12 Botanical	\$18.53	\$16.68	\$15.85
A20508-1209	12 Colors	18.53	16.68	15.85
A20508-1049	12 Landscape	18.53	16.68	15.85
A20508-1039	12 Under the Sea	18.53	16.68	15.85
A20508-2409	24 Colors	35.99	32.39	30.77
A20508-0249	24 Portraiture	35.99	32.39	30.77
A20508-1089	24 Highlighting and Shading	40.84	36.76	34.92
A20508-0036	36 Colors	49.99	44.99	42.74
A20508-4809	48 Colors	66.99	60.29	57.28
A20508-7209	72 Colors	95.99	86.39	82.07
A20508-1329	132 Colors	183.30	164.97	156.72
A20508-0150	150 Colors	204.47	184.03	165.63

Botanical

Landscape

Under the Sea



Kingart® Colored Pencils

Perfect for professionals, aspiring artists looking to tap their inner creative, and beginners just starting out, Kingart Colored Pencils have velvety soft cores that blend and layer smoothly, sharpen to a fine point, and resist breaking. Great for all kinds of colored pencil work, each carefully chosen set comes in a sturdy, reusable metal box for ease of storage and transport.

NUMBER	SET	EACH	6/EA
A22683-1129	12 Colors	\$10.06	\$9.05
A22683-1249	24 Colors	17.62	15.86
A22683-1729	72 Colors	47.24	42.53



Caran D'Ache Colorblock Maxi Metallic Pencils

Add shimmer and shine to drawings, sketches, handmade cards, and decorations. Great for drawing, building up colors, scrapbooking, decorating, and more, these metallic colored pencils have large 10 mm diameter, FSC-certified wood casings that are easy to grip, and extra-large (4.5 mm) wax-based cores for smooth, generous applications of color. A high pigment concentration assures bright, intense colors.

NUMBER	COLOR	EACH	12/EA
A67946-8150	Bronze	\$4.14	\$3.73
A67946-9320	Gold	4.14	3.73
A67946-7840	Green	4.14	3.73
A67946-3080	Scarlet	4.14	3.73
A67946-9360	Silver	4.14	3.73



Blick® Studio Charcoal

Blick's Studio Charcoal is crafted for optimum performance at a price artists can afford. Choose Vine or Willow in a variety of hardnesses to suit any project. Sticks measure 5-1/2" x 3/16"Dia. The Vine Medium Canister contains 144 sticks.

NUMBER	DESCRIPTION	EACH	6/EA
A21962-2270	Vine Extra Soft, 12-pack	\$6.99	\$6.31
A21962-2271	Vine Soft, 12-pack	6.99	6.31
A21962-2272	Vine Medium, 12-pack	6.99	6.31
A21962-2273	Vine Hard, 12-pack	6.99	6.31
A21962-2130	Willow Ex Soft, 12-pack	6.99	6.31
A21962-2131	Willow Soft, 12-pack	6.99	6.31
A21962-2132	Willow Medium, 12-pack	6.99	6.31
A21962-2133	Willow Hard, 12-pack	6.99	6.31
A21962-2279	Vine Medium Canister	79.47	71.53



General's® Specialty Drawing Pencil Classroom Pack

This handy stand-up pencil pack is ideal for classrooms, studios, and galleries. It holds three dozen each of General's Layout® Drawing Pencils, Carbon Sketch™ Drawing Pencils, and Sketch & Wash® Watersoluble Graphite Drawing Pencils, for a wide variety of sketching and drawing techniques.

NUMBER	DESCRIPTION	EACH	3/EA
A22459-1108	Classroom Pack of 108	\$111.14	\$100.03

Conté à Paris® Compressed Charcoal

Genuine deep black charcoal in round sticks that measure 3-7/8"L x 5/16"Dia. Choose from an assortment of 12 sticks in fine gradations from 4B (Very Soft) to HB (Hard), or a box of 12 of one hardness.

NUMBER	DESCRIPTION	EACH	12/EA
A20044-2139	Assorted	\$36.78	\$33.11
A20044-9000	4B-Very Soft	36.78	33.11
A20044-3012	3B-Soft	36.78	33.11
A20044-2020	2B-Soft	36.78	33.11
A20044-1012	HB-Hard	36.78	33.11

Wolff's Carbon Pencils

The perfect combination of charcoal and graphite — consistent softness for blending and texture, plus sharpness for details. Finely grained, these pencils apply smoothly and precisely, with good blendability and rich, velvety, matte black lines. The 5 mm core is encased in a natural cedar wood barrel, making them easy to use and sharpen. Four degrees: B, 2B, 4B, and 6B.

NUMBER	DESCRIPTION	EACH	12/EA	24/EA
A20452-2001	B	\$3.27	\$2.94	\$2.79
A20452-2021	2B	3.27	2.94	2.79
A20452-2041	4B	3.27	2.94	2.79
A20452-2061	6B	3.27	2.94	2.79



Cretacolor® Charcoal Drawing Set

Explore the rich world of black with this 20-piece drawing set. It includes three charcoal pencils (soft, medium, and hard), three Nero pencils (soft, medium, and hard), two Monolith solid pencil-size sticks of pure graphite (9B and 6B), five grades of compressed charcoal, four willow charcoal sticks, a charcoal block, a kneaded eraser, and a paper blending stick. Hinge-lid metal box. Made in Austria.

NUMBER	EACH	3/EA
A20445-1009	\$36.64	\$32.98

General's® Charcoal Pencils

An excellent-quality pencil made of highly refined willow charcoal and fine organic blacks available in degrees of Black and one degree of White (which can be worked over the Black). Smooth cedar casings.

NUMBER	STYLE	EACH	12/EA	72/EA
A20418-2030	HB Black	\$1.18	\$1.05	\$9.99
A20418-2021	2B Black	1.18	1.05	.99
A20418-2041	4B Black	1.18	1.05	.99
A20418-2061	6B Black	1.18	1.05	.99
A20418-1001	White	1.18	1.05	.99

Set of 5 — One each of 2B, 4B, 6B in Black, one White, and a kneaded eraser.

NUMBER	EACH	12/EA	24/EA
A20418-1009	\$4.59	\$4.19	\$3.99

Set of 8 — One each HB, 2B, 4B Charcoal pencils, two 6B Charcoal pencils, one Charcoal White 558 pencil, one Carbon Sketch pencil, and an All-Art Sharpener.

NUMBER	EACH	6/EA	12/EA
A20418-1089	\$7.25	\$6.58	\$6.35

Class Pack of 72 Pencils — Includes 24 each of 2B, 4B, and 6B.

NUMBER	EACH	6/EA
A20418-1019	\$82.85	\$74.99

General's® Carbon Sketch Pencil

Combining the smoothness of graphite with the deep, rich blacks of charcoal, this fine 4B pencil has a unique formula that lays down smooth, strong, jet-black lines for sketching, drawing, or layout. Perfect used alone, it can be combined with charcoal or graphite for a variety of effects. Box of 12.

NUMBER	EACH	12/EA	24/EA
A20459-2120	\$16.04	\$14.75	\$13.99

Prang® Wrap Charcoal Pencils

Finest quality for the beginning artist to the professional illustrator. Paper-wrapped for strength and cleanliness. Use the easy pull string to expose the point.

NUMBER	DESCRIPTION	EACH	12/EA	24/EA
A20441-1002	Medium	\$1.61	\$1.45	\$1.38
A20441-1003	Soft	1.61	1.45	1.38

Derwent® Charcoal Pencils

Excellent for detail work, these cedar-barreled pencils contain the highest-quality flexible charcoal with no imperfections that might scratch your work. Easier sharpening with less breakage.

NUMBER	DESCRIPTION	EACH	12/EA	24/EA
A20313-1001	Light	\$1.98	\$1.78	\$1.70
A20313-1002	Medium	1.98	1.78	1.70
A20313-1003	Dark	1.98	1.78	1.70

General's® Pencil #15 Charcoal Drawing Kit

All the tools you need to make drawings come alive. The 13-piece kit includes seven pencils (two 6B and one each of HB, 2B, 4B, Charcoal White, and Carbon Sketch), four sticks of compressed charcoal, and two soft sticks (one jumbo stick and one White stick). A handy artist's pencil sharpener and kneaded eraser complete the set.

NUMBER	EACH	6/EA	12/EA
A20460-1009	\$13.11	\$11.99	\$11.40



Coates Willow Charcoal Powder

Made by grinding willow charcoal sticks into a fine powder, this versatile drawing material can be applied with fingers, blending tools, or a wet brush to paper, card, canvas, and other absorbent surfaces to create different wash tones and hues. It can also be mixed with paint for mixed media applications. 500 ml jar.

NUMBER	EACH	6/EA
A22666-2135	\$27.86	\$25.07

General's® Charcoal Drawing Assortment

This versatile set is an ideal introduction to all charcoal media. Includes two charcoal pencils (with premium incense cedar wood barrels), three compressed charcoal sticks, four willow sticks, a sharpener, and a kneaded eraser for erasing and highlighting.

NUMBER	EACH	6/EA
A21938-1009	\$11.62	\$10.46

General's® Jumbo Charcoal

Package of three Jumbo Charcoal Sticks. They may be sharpened to a point for detailed work and blended easily with a paper stub. Sticks are 3"L x 1/2"W x 1/4" thick.

NUMBER	DESCRIPTION	EACH	6/EA	12/EA
A22921-0000	Assorted, Set of 3	\$3.68	\$3.37	\$3.21
A22921-2022	2B Jumbo, Box of 6	6.40	5.76	5.48
A22921-2024	4B Jumbo, Box of 6	6.40	5.76	5.48
A22921-2026	6B Jumbo, Box of 6	6.40	5.76	5.48

Faber-Castell® Pitt® Compressed Charcoal Sticks

Handmade from a mixture of soot and willow charcoal to provide the deepest possible black stroke, these charcoal sticks are great for covering large areas. Available in three degrees of hardness, the sticks measure approximately 3-1/4"L x 1/8"Dia but may vary slightly in size. Packs contain three sticks of one hardness.

NUMBER	DESCRIPTION	EACH	12/EA
A22617-2000	3 Extra Soft	\$6.90	\$6.22
A22617-2001	3 Soft	6.90	6.22
A22617-2012	3 Medium	6.90	6.22

Alphacolor® Quartet Char-Kole® Squares

Excellent-quality rich black blends smoothly and is free of hard spots. Sticks are 2-3/4"L x 7/16"Sqr. Box of 12 sticks. Non-toxic.

NUMBER	EACH	12/EA
A20003-2009	\$8.52	\$8.14



Coates Premium Artist Willow Charcoal

Charcoal is a simple yet indispensable tool for fine artists. Five sizes: Thin 3-4 mm, Medium 5-6 mm, Thick 7-9 mm, Extra Thick 10-15 mm, and the Tree Stick 16-24 mm. Sticks are approximately 6" long.

NUMBER	DESCRIPTION	EACH	12/EA
A20072-0000	Thin-25 Sticks/Box	\$8.54	\$7.69
A20072-1000	Med-25 Sticks/Box	8.54	7.69
A20072-2000	Thick-12 Sticks/Box	8.54	7.69
A20072-3000	Ex. Thick-4 Sticks/Box	9.95	8.96
A20072-4000	Tree-1 Stick	4.58	4.12

Assorted Box of 30 Sticks — One Extra Thick, five Thick, 12 Medium, and 12 Thin. Approximately 3" long.

NUMBER	EACH	12/EA
A20072-5000	\$8.54	\$7.69



Bob's Fine Vine Charcoal

Made in Eugene, Oregon, since 1986, Bob's Fine Vine Charcoal is made from select hardwood and processed at a specific temperature to attain its high quality, smooth consistency, and rich, black color. This assortment of four large sticks (6"L x 3/4"Sqr) and 20 small sticks (6"L x 1/4"Sqr) is priced so that artists and students can use this charcoal freely and enjoy its wonderful working properties.

NUMBER	EACH	12/EA
A20056-0000	\$17.07	\$15.36



Winsor & Newton® Vine & Willow Charcoal

This highest-quality charcoal is carefully selected for uniformity without imperfections. Vine charcoal is dark gray; willow charcoal is black. 12 sticks per box.

NUMBER	DESCRIPTION	EACH	12/EA	24/EA
A22989-1012	Soft	\$10.69	\$9.62	\$9.15
A22989-1103	Medium	10.69	9.62	9.15
A22989-1104	Hard	10.69	9.62	9.15

NUMBER	DESCRIPTION	EACH	12/EA	24/EA
A22988-1003	Assortment	\$10.69	\$9.62	\$9.15
A22988-1004	Medium	10.69	9.62	9.15
A22988-1005	Thick	10.69	9.62	9.15



Cretacolor® Chunky Charcoal Colors

Ideal for large-scale drawings on various types of paper, each stick is 3-3/8"L x 5/8"Dia for bold, intense lines.

NUMBER	COLOR	EACH	12/EA	24/EA
A22811-0001	Olive Brown	\$3.90	\$3.50	\$3.27
A22811-7911	Olive Green Dark			
A22811-8082	Sepia Dark			

Three Black

NUMBER	EACH	12/EA	24/EA
A22811-2023	\$11.17	\$10.05	\$9.54

12-Piece Set — Includes one charcoal stick, one graphite stick, and one stick of Dark Ochre, Dark Olive Green, Dark Sepia, Light Earth Green, Light Ochre, Light Sanguine, Olive Brown, Payne's Gray, Permanent White, and Silver Gray.

NUMBER	EACH	6/EA	12/EA
A22811-0009	\$42.37	\$38.52	\$36.60

Grumbacher® Charcoal

Grumbacher Vine Charcoal is created by burning hand-selected vines at high temperatures to produce a beautiful range of velvety grays, from dark, soft charcoal to light, hard charcoal. Choose Hard, Medium, Soft, or Extra Soft sticks. Grumbacher's Willow Charcoal sticks are cooked to a uniform medium hardness. Choose Thin, Medium, or Thick cylindrical sticks.

NUMBER	DESCRIPTION	EACH	6/EA
A22095-2130	Hard-12 Sticks/Box	\$10.59	\$9.53
A22095-2120	Medium-12 Sticks/Box	10.59	9.53
A22095-2112	Medium Square-12 Sticks/Box	10.59	9.53
A22095-2110	Soft-12 Sticks/Box	10.59	9.53
A22095-2100	Extra Soft-12 Sticks/Box	10.59	9.53
A22095-2125	Medium, Jumbo-25 Sticks/Box	74.99	67.50

NUMBER	DESCRIPTION	EACH	6/EA
A22607-1010	Thin-12 Sticks/Box	\$7.95	\$7.16
A22607-1020	Medium-12 Sticks/Box	7.95	7.16
A22607-1030	Thick-4 Sticks/Box	7.95	7.16



Nitram® Liquid Charcoal

Imagine painting with charcoal! This water-soluble form of artist's charcoal allows values to be adjusted from very light to a deep, rich black. Straight out of the tube, Liquid Charcoal is as thick as oil paint, suitable for use with a palette knife. It dries very quickly and can be erased when completely dry. 1.69 oz (50 ml) tube.

NUMBER	EACH	12/EA
A22685-1003	\$24.44	\$21.99



Conté à Paris® Crayons

Invented more than 215 years ago, Conté à Paris crayons are hard pastels that are smooth and richly pigmented. Sticks are 2-1/2"L x 1/4"Sqr. Box of 12 of one color.

NUMBER	COLOR	EACH	12/EA
A20201-8259	Bistre	\$25.65	\$23.09
A20201-2010	Black - B	25.65	23.09
A20201-2020	Black - 2B	25.65	23.09
A20201-2051	Black - HB	25.65	23.09
A20201-8529	Sanguine Natural	25.65	23.09
A20201-1010	White - B	25.65	23.09
A20201-3021	White - 2B	25.65	23.09
A20201-4021	White - HB	25.65	23.09

Assorted 12-Pack — Includes Bistre, Sanguine Medicis, Sanguine Watteau, Sanguine XVIII Century, Sanguine, White B, Gray, Black HB, Black B (x2), and Black 2B (x2).

NUMBER	EACH	6/EA
A20201-1009	\$25.65	\$23.09

Individual Crayons — Package of two crayons.

NUMBER	COLOR	EACH	12/EA
A20201-8252	Bistre	\$4.45	\$3.99
A20201-2110	Black - B	4.45	3.99
A20201-2120	Black - 2B	4.45	3.99
A20201-2050	Black - HB	4.45	3.99
A20201-2612	Gray	4.45	3.99
A20201-8912	Sanguine Medici	4.45	3.99
A20201-8812	Sanguine Natural	4.45	3.99
A20201-8712	Sanguine Watteau	4.45	3.99
A20201-1110	White - B	4.45	3.99
A20201-1000	White - 2B	4.45	3.99
A20201-1030	White - HB	4.45	3.99



Assorted 4-Pack — A convenient four-pack that includes one each of B Black, 2B White, Sanguine Natural, and Bistre.

NUMBER	EACH	12/EA
A20201-0049	\$4.67	\$4.20

STAEDTLER® Mars® Lumograph® Charcoal Pencil Sets

Perfect for sketching, layouts, and adding details to finished artwork. The set of four includes 2B, 4B, and 6B charcoal pencils, plus a soft white chalk pencil. The set of seven includes a 2B, 4B, and 6B charcoal pencil, plus a soft white chalk pencil, metal pencil sharpener, kneadable eraser, and double-ended paper stump.

NUMBER	DESCRIPTION	EACH	6/EA
A20470-1049	Set of 4	\$5.29	\$4.76
A20470-1079	Set of 7	9.72	8.75



General's® Peel & Sketch® Charcoal Pencils

There's no need for a sharpener with Peel and Sketch Charcoal Pencils. Just pull the string to peel away the paper and reveal more charcoal! This black, velvety smooth charcoal works great for creating quick sketches and drawings.

Set of 3 — One each of soft, medium, and hard, plus a kneaded eraser.

NUMBER	EACH	6/EA
A21910-1003	\$4.39	\$3.95

Set of 72 — Two dozen each of soft, medium, and hard.

NUMBER	EACH	6/EA
A21910-1036	\$117.79	\$105.99



General's® Charcoal Sticks

Extra-smooth, high-quality charcoal sticks offer rich, intense, blendable blacks to create broad strokes or fine details.

NUMBER	DESCRIPTION	EACH	6/EA	12/EA
A22921-2001	4 Assorted	\$3.68	\$3.37	\$3.21
A22921-2012	2B, Box of 12	11.32	10.19	9.69
A22921-2014	4B, Box of 12	11.32	10.19	9.69
A22921-2020	6B, Box of 12	11.32	10.19	9.69

White Charcoal — White, smooth, compressed sketching sticks. 3"L x 1/4"Sqr sticks.

NUMBER	DESCRIPTION	EACH	6/EA	12/EA
A22921-1001	Pack of 4	\$3.84	\$3.52	\$3.35
A22921-1021	Box of 12	9.90	8.91	8.47



Yarka® Sanguine and Sepia Drawing Crayon Set

Made from high-grade pigments and Chasov Yar clay, Yarka Classic Drawing Crayons are hard pastel sticks for use on paper, board, or primed canvas. Sanguine is a Reddish-Brown color, much like Sienna, and Sepia is Yellowish-Brown and resembles Umber. The 20-crayon set includes five each of Light Sanguine, Dark Sanguine, Light Sepia, and Dark Sepia packaged in a varnished, slide-top wood box. Crayons measure 2-1/4"L x 3/8"Dia.

NUMBER	EACH	6/EA	12/EA
A20046-1009	\$15.36	\$14.12	\$13.40



General's® Charcoal Classroom Art Pack™

An economical assortment of everything you need for students to draw with charcoal. Includes 24 each of 2B and 6B charcoal pencils, 24 each of Charcoal White and Carbon Sketch pencils, plus 24 sticks of compressed charcoal, one box of willow charcoal, 12 sandpaper paddles, 12 All-Art sharpeners, 18 Magic Black erasers, and 24 tortillons.

NUMBER	EACH	6/EA
A20418-1029	\$201.99	\$181.99



General's® Compressed Charcoal Class Pack

Includes a variety of square and rectangular sticks (2B, 4B, and 6B) and 24 White sticks. 114 pieces total.

NUMBER	EACH	3/EA
A21939-1001	\$90.64	\$81.58



Cretacolor® Drawing Sets

Every product in these sets is lightfast with superior pigmentation and crafted from the best-quality cedar wood. The 10-piece set includes one each of monolith graphite 4B, Nero extra-soft black drawing pencil, black charcoal #1 soft pencil, white sanguine and sepia chalk pencils, sanguine chalk, a sketching coal stick, a kneaded eraser, and a paper blending stump. The 27-piece set contains a wide variety of traditional drawing materials, from chalks and pencils to graphite sticks and charcoals.

NUMBER	DESCRIPTION	EACH	12/EA	24/EA
A20476-2010	10-Piece, Artino	\$24.79	\$22.31	\$21.20
A20476-2027	27-Piece, Creativo	45.76	41.18	39.11



A General's® Drawing Pencil Set No. 10

An assortment of popular styles of drawing items in a handy sketching box. Set includes two flat sketching pencils, three charcoal pencils (2B, 4B, 6B), one Kimberly pencil (4B), two layout pencils, one Charcoal White, three compressed graphite sticks (2B, 4B, 6B), and one Sketch and Wash Pencil.

NUMBER	EACH	12/EA
A20417-2008	\$12.13	\$10.91

B General's® Drawing Pencil Set No. 20

A complete drawing and sketching set that includes 10 pastel chalk pencils in assorted colors, four charcoal pencils (HB, 2B, 4B, 6B), one charcoal white pencil, two flat sketching pencils, one layout pencil, one extra soft Kimberly Drawing Pencil, a kneaded eraser, and a pencil sharpener.

NUMBER	EACH	12/EA
A20422-2009	\$22.33	\$20.10



General's® Sketchmate™ Set

This complete sketching set is ideal for beginning and experienced artists alike — high-quality products at a low price. It includes three degrees of graphite, two degrees of charcoal, a 1555 layout pencil, a sandpaddle sharpener, a white eraser, a blending tortillon, and a plastic sharpener for fine charcoal and graphite pencils. PMA-approved.

NUMBER	EACH	6/EA
A22926-1009	\$6.46	\$5.80



General's® Sketchmate™ Classroom Art Pack

Everything you need to get your class started drawing — charcoal and semi-hex drawing pencils, extra-black layout pencils, white charcoal pencils, sandpaper paddles, sharpeners, tortillons, and extra-soft erasers. Also includes a project book with graphite, charcoal pencil, and cartooning techniques.

NUMBER	EACH	6/EA
A22888-1009	\$197.48	\$177.73



Caran d'Ache® Technalo Water Soluble Graphite Pencils

Technalo Water Soluble Graphite Pencils contain an aquarelle lead, allowing uniform darkening of large surfaces, and regular, intense lines. Technalo Water Soluble Colored Graphite Pencils combine the qualities of a colored pencil with a watersoluble graphite lead. Used dry, they retain the original properties of graphite. Used wet, the black is tinted with subtle shades of Carmine Lacquer, Dark Phthalo Green, and Prussian Blue for subtle colored washes. The end result is exceptionally lightfast.

NUMBER	COLOR	HARDNESS	EACH	12/EA
A22703-2001	Graphite	B	\$3.58	\$3.22
A22703-2030	Graphite	3B	3.58	3.22
A22703-2060	Graphite	6B	3.58	3.22
A22703-5010	Blue	3B	3.99	3.59
A22703-7010	Green	3B	3.99	3.59
A22703-3010	Red	3B	3.99	3.59



Derwent® Drawing Pencils

These traditional artist's pencils have soft, creamy leads to allow blending of a variety of colors and tones. The colors can be quickly laid down in wide to thin applications. Extra-thick 5.5 mm round leads.

Colors can be assorted for quantity pricing.

NUMBER	COLOR	EACH	12/EA
A20312-8211	Brown Ochre	\$2.75	\$2.48
A20312-1051	Chinese White	2.75	2.48
A20312-8101	Chocolate	2.75	2.48
A20312-2251	Ivory Black	2.75	2.48
A20312-8171	Terracotta	2.75	2.48
A20312-3131	Venetian Red	2.75	2.48



Derwent® Drawing Pencil Sets

Responding to popular demand, Derwent has expanded its initial range of six earthy colors (see above) into a glorious palette of 24 subtle shades. These include soft greens, blues, grays, and creams, plus a wider choice of traditional sepia tones, making them ideal for a wide range of subjects.

NUMBER	SET	EACH	6/EA
A22048-1006	6 Colors	\$13.79	\$12.41
A22041-0129	12 Colors	34.09	30.68
A22041-0249	24 Colors	68.59	61.73



Conté à Paris® Sketching Pencils

Large, round, wood-cased pencils have rich colors with an abrasive for easier stumping. Excellent for portraits and landscapes. Sharpen with a razor blade or knife. Colors and grade can be assorted for quantity pricing.

NUMBER	COLOR	EACH	12/EA
A20425-2031	Black - 3B	\$3.05	\$2.73
A20425-2021	Black - 2B	3.05	2.73
A20425-2011	Black - B	3.05	2.73
A20425-2051	Black - HB	3.05	2.73
A20425-1006	Carbon 3B	3.05	2.73
A20425-1005	Carbon 2B	3.05	2.73
A20425-1004	Carbon HB	3.05	2.73
A20425-8911	Sanguine	3.05	2.73
A20425-1003	Sanguine XVIII Century	3.05	2.73
A20425-1002	Sanguine Medicis	3.05	2.73
A20425-8081	Sepia	3.05	2.73
A20425-1001	White	3.05	2.73
NUMBER	SET	EACH	12/EA
A20425-0069	6 Assorted	\$18.11	\$16.31



General's® Primo® Euro Blend™ Charcoal Pencils

Handmade in small batches with rich, organic blacks to achieve intense drawing tones and values, Primo Euro Blend offers a premium charcoal drawing experience. Deluxe Set includes three Primo Euro Blend pencils, a Primo Bianco pencil, a Primo Elite Grande pencil, four Primo compressed charcoal sticks, two erasers, and a sharpener. Class pack includes two dozen each of HB, B, 3B, and White. For contents of six-piece set, visit DickBlick.com. Made in the USA.

NUMBER	DESCRIPTION	EACH	12/EA
A20495-1020	White	\$1.78	\$1.60
A20495-2090	Hard HB	1.78	1.60
A20495-2000	Soft B	1.78	1.60
A20495-2030	Extra Soft 3B	1.78	1.60
A20495-2131	Grande (Extra Soft)	2.33	2.10

NUMBER	DESCRIPTION	EACH	6/EA
A20495-1009	6-piece Set	\$7.71	\$6.94
A20495-2009	Deluxe Set	17.11	15.40
A20495-1249	Class Pack of 96	144.99	130.50



Cretacolor® Silverpoint Pencil

A type of metal point used by artists since ancient times, silverpoint styli are traditionally used for writing on soft surfaces, underdrawing on parchment, and drawing on paper and panels. This traditional silverpoint pencil can be used for making highly detailed marks on clayboard and similar surfaces. It can also be used with aqua sticks to add color. It has a wood barrel with a highly polished black finish.

NUMBER	EACH	6/EA
A19783-2020	\$16.72	\$15.05

Blackwing® Palomino® Pencils - Natural

Whatever you're up to, there's a Blackwing pencil right for the job. Choose the 602 for everyday use, the Pearl for lettering and line work, or the original Blackwing for illustrating and scoring. All feature lacquered California incense cedar semi-hexagonal barrels, premium Japanese graphite crafted with clay for strength and wax for smoothness, and replaceable flat erasers. Packs of 12.

NUMBER	EACH
A20699-8450	\$27.00



STAEDTLER® Mars® Lumograph Drawing & Sketching Pencils

The highest-quality graphite glides smoothly over paper and is easy to erase. The length of the pencil lead is bonded to the wood to help prevent breakage, especially while sharpening. Set of 24 offers 20 hardness degrees, plus four Lumograph Black pencils (8B, 6B, 4B, and 2B), in a metal box.

NUMBER	SET	EACH	6/EA
A20438-1069	6 Pencils	\$10.79	\$9.71
A20438-1129	12 Pencils	21.47	19.32
A20438-1249	24 Pencils	41.38	37.24



NUMBER	DESCRIPTION	EACH	12/EA	24/EA
A20438-2001	B	\$2.03	\$1.83	\$1.73
A20438-0002	2B	2.03	1.83	1.73
A20438-2031	3B	2.03	1.83	1.73
A20438-0004	4B	2.03	1.83	1.73
A20438-2051	5B	2.03	1.83	1.73
A20438-0006	6B	2.03	1.83	1.73
A20438-2071	7B	2.03	1.83	1.73
A20438-2081	8B	2.03	1.83	1.73
A20438-2091	9B	2.03	1.83	1.73
A20438-2101	F	2.03	1.83	1.73
A20438-2030	HB	2.03	1.83	1.73
A20438-2020	H	2.03	1.83	1.73
A20438-2022	2H	2.03	1.83	1.73
A20438-2032	3H	2.03	1.83	1.73
A20438-2042	4H	2.03	1.83	1.73
A20438-2052	5H	2.03	1.83	1.73
A20438-2062	6H	2.03	1.83	1.73
A20438-2072	7H	2.03	1.83	1.73
A20438-2082	8H	2.03	1.83	1.73
A20438-2092	9H	2.03	1.83	1.73

STAEDTLER® Mars® Lumograph® Black Drawing Pencils

These premium-quality pencils have a high proportion of carbon for matte, jet black results. The set includes four different degrees, particularly suitable for drawing and hatching as well as for expressive sketches and portraits.

NUMBER	DESCRIPTION	EACH	12/EA
A22470-2022	2B	\$2.46	\$2.17
A22470-2024	4B	2.46	2.17
A22470-2026	6B	2.46	2.17
A22470-2028	8B	2.46	2.17

Set of 6 — Includes one each of 8B and 6B, and two each of 4B and 2B.

NUMBER	DESCRIPTION	EACH	6/EA
A22470-1001	6 Pencils	\$12.46	\$11.21



Derwent® Sketching Collections

An ideal gift for the serious drawing student. Metal boxes with removable lids hold assortments of sketching pencils, graphite sticks, pastel pencils, compressed charcoal, and accessories.

NUMBER	SET	EACH	3/EA
A20404-0009	12 Items	\$23.84	\$21.46
A20404-0019	24 Items	47.67	42.89

Derwent® Graphic Pencils

Made from the finest-quality graphite and purest clays for a smooth line. Ideal for crisp, detailed illustrations or tone drawings. Hexagonal matte black barrel with a distinctive dark orange band. Choose from three styles. 12 pencils per set.

NUMBER	DESCRIPTION	EACH	12/EA
A20404-2019	Soft Sketch	\$23.70	\$21.33
A20404-2029	Med. Designer	23.70	21.33
A20404-2039	Hard Technical	23.70	21.33



Lyra™ Rembrandt Art Design Graphite Pencil Set

Superior break-resistance and consistent grading make Art Design pencils ideal for graphics, design, art, and architecture. The set includes one each of 6B, 5B, 4B, 3B, 2B, B, HB, F, H, 2H, 3H, and 4H.

NUMBER	EACH	6/EA
A22230-0129	\$17.41	\$15.67



Wolff's Graphite Sketch Set

Premium-quality sketching pencils manufactured with wood from managed forests. Set includes six sketching pencils (HB through 8B), a Wolff's broad carbon stick, soft eraser, and a metal sharpener, packed in a reusable metal box. Conforms to ASTM D-4236.

NUMBER	EACH	12/EA
A20475-1009	\$16.11	\$14.49



Cretacolor® Artist's Basic Drawing Set

Start sketching with a Cretacolor collection of fine materials made in Austria. 10-piece set includes Monolith solid pencil-size stick of pure graphite, Nero extra-soft black drawing pencil, black charcoal #1 soft pencil, one each of White, Sanguine, and Sepia chalk pencils, Sanguine pastel stick, charcoal stick, kneaded eraser, and paper blending stick, in an attractive hinge-lid metal box.

NUMBER	EACH	6/EA
A20444-1009	\$24.79	\$22.31



ArtGraf® Viarco® Graphite Powder

If you enjoy working with watersoluble graphite, you'll love creating your own shades and hues with Viarco Graphite Powder. Use a little, use a lot — the possibilities are unlimited. With watersolubility and fixing properties incorporated into its formula, this powder allows precise control over gray shades simply by adjusting the ratio of water to powder. It can also be mixed with other waterbased materials to create more colors, tones, and textures. Graphite marks can be erased or rewet when dry. 250 g bag.

NUMBER	EACH	6/EA
A22680-1001	\$25.97	\$23.37

Lyra™ Graphite Crayons

Approximately 4-1/2"L x 1/2"Dia, these hexagonal crayons are excellent for sketching, layout, and design. They glide over most papers. The paper covering keeps hands clean in the process.

NUMBER	DESCRIPTION	EACH	12/EA
A20443-2021	2B	\$1.60	\$1.44
A20443-2061	6B	1.60	1.44
A20443-2091	9B	1.60	1.44
A20443-1009	Classroom Pack of 24	38.56	34.70

Watersoluble — Use with a brush and water for monochromatic watercolor effects. Non-staining and erasable when dry.

NUMBER	DESCRIPTION	EACH	12/EA
A20443-2121	2B	\$1.60	\$1.44
A20443-2161	6B	1.60	1.44
A20443-2191	9B	1.60	1.44
A20443-1019	Classroom Pack of 24 Watersoluble	38.56	34.70

Derwent® XL Graphite Blocks

The chunky shape of these extra-large graphite blocks makes them captivating, intuitive, and great fun to use. Available in a variety of rich, dense colors, you can create different marks with the sides, edges, and corners — or use an embossing tool to create lines and add texture. XL blocks are very tactile, so you can use your finger to smudge and move the color around, too. The blocks measure approximately 3/4" x 3/4" x 2-1/4".

NUMBER	COLOR	EACH	12/EA
A19782-8050	Burnt Umber	\$6.88	\$6.19
A19782-7580	Dark Prussian	6.88	6.19
A19782-7070	Olive Green	6.88	6.19
A19782-8070	Raw Umber	6.88	6.19
A19782-1001	Graphite Extra Soft	6.88	6.19
A19782-1000	Graphite Soft	6.88	6.19

NUMBER	DESCRIPTION	EACH	3/EA
A19782-1006	Set of 6	\$40.52	\$36.47



A Koh-I-Noor® Progresso Woodless Graphite Pencils

The Progresso's solid, weighty feel and excellent laydown make it a great pencil for drawing and sketching. An economical choice, these lacquer-coated, blendable graphite pencils outlast standard wood-cased pencils. They can be sharpened in any electric or manual pencil sharpener.

NUMBER	DESCRIPTION	EACH	12/EA	24/EA
A22222-2100	HB	\$1.82	\$1.64	\$1.56
A22222-2102	2B	1.82	1.64	1.56
A22222-2104	4B	1.82	1.64	1.56
A22222-2106	6B	1.82	1.64	1.56
A22222-2108	8B	1.82	1.64	1.56
A22222-2109	9B	1.82	1.64	1.56



General's® Sketching Pencils

This oval pencil with rectangular lead is just the thing for quick, loose sketching, shading, or filling in large areas. Wood case sharpens easily with a knife.

NUMBER	DESCRIPTION	EACH	12/EA	24/EA
A20413-2061	6B (softest)	\$1.75	\$1.56	\$1.48
A20413-2041	4B	1.75	1.56	1.48
A20413-2021	2B	1.75	1.56	1.48



General's® Kimberly Graphite Sticks

These soft, smooth graphite sticks are made for sketching and shading. Sticks measure 3"L x 1/4"Sqr. Boxes of 12.

NUMBER	DESCRIPTION	EACH	12/EA	24/EA
A20414-2092	2B	\$9.21	\$8.28	\$7.88
A20414-2094	4B	9.21	8.28	7.88
A20414-2069	6B	9.21	8.28	7.88

144-ct Class Pack — Includes two dozen each of square and rectangular sticks in 2B, 4B, and 6B grades.

NUMBER	EACH
A20414-1449	\$91.54

ArtGraf® No. 1 Graphite Putty

Drawing will never be the same when you discover ArtGraf No. 1. This kneadable, watersoluble graphite can be molded into any shape you want — use the entire piece, or pinch off only what you need to make broad or thin marks. Roll it, blot it, work large, work small, work dry, work wet! The marks this unique drawing medium makes on paper are erasable and reworkable when dry, and can also be rewet to adjust shades or colors. 5 oz resealable pouch.

NUMBER	EACH	12/EA
A22791-2614	\$16.10	\$14.49

B General's® Pure Woodless Graphite

Made of pure graphite in a convenient pencil shape and size, these woodless wonders give you more of what you want in a graphite pencil. Perfect for creating broad strokes, they also can be sharpened to a point for fine details. No wood shaving mess!

NUMBER	DESCRIPTION	EACH	12/EA	24/EA
A20461-2081	Extra Soft	\$2.39	\$2.15	\$2.04
A20461-2061	Smooth 6B	2.39	2.15	2.04
A20461-2041	Smooth 4B	2.39	2.15	2.04
A20461-2021	Smooth 2B	2.39	2.15	2.04
A20461-2030	Smooth HB	2.39	2.15	2.04

Set of 4 — Includes four smooth Woodless Graphite pencils in HB, 2B, 4B, and 6B, and a handheld sharpener.

NUMBER	EACH	6/EA	12/EA
A20461-1009	\$9.98	\$9.05	\$8.61

C Cretacolor® Monolith Woodless Pencils

Purest graphite from Austria in a 7 mm solid stick with a protective lacquer coating. Artists are thrilled by the broad and fine strokes that can easily be achieved with only one pencil. From HB medium to 9B extra soft. Black.

NUMBER	DESCRIPTION	EACH	12/EA	24/EA
A20442-2030	HB (hardest)	\$2.14	\$1.92	\$1.83
A20442-2021	2B	2.14	1.92	1.83
A20442-2041	4B	2.14	1.92	1.83
A20442-2061	6B	2.14	1.92	1.83
A20442-2081	8B	2.14	1.92	1.83
A20442-2091	9B	2.14	1.92	1.83



Cretacolor® Monolith 10-Piece Tin Set

Includes six Cretacolor Monolith pencils in different densities, a marbled monolith extender with cap, a watersoluble 9B Monolith pencil, a metal sharpener, and a kneaded eraser in a sleek metal storage box.

NUMBER	EACH	12/EA	24/EA
A20442-0009	\$32.05	\$28.84	\$27.39





A Blick Studio Drawing Pencils

Create dramatic effects in your illustrations, drawings, and sketches. Professional-quality graphite leads are lightfast, clean-erasing, and offer high opacity, encased in lacquered cedar casings with a hexagonal shape to prevent them from rolling off surfaces. Grades are printed on all six sides for quick reference.

NUMBER	HARDNESS	EACH	12/EA	24/EA
A22220-2061	6B	\$1.34	\$1.20	\$1.15
A22220-2051	5B	1.34	1.20	1.15
A22220-2041	4B	1.34	1.20	1.15
A22220-2031	3B	1.34	1.20	1.15
A22220-2021	2B	1.34	1.20	1.15
A22220-2100	B	1.34	1.20	1.15
A22220-2110	HB	1.34	1.20	1.15
A22220-2120	F	1.34	1.20	1.15
A22220-2130	H	1.34	1.20	1.15
A22220-2022	2H	1.34	1.20	1.15
A22220-2042	4H	1.34	1.20	1.15
A22220-2062	6H	1.34	1.20	1.15



12-Pencil Set — Contains one each of 6B, 5B, 4B, 3B, 2B, B, HB, F, H, 2H, 4H, and 6H.

NUMBER	EACH	3/EA
A22220-2009	\$15.85	\$10.21

B Prismacolor® Turquoise® Drawing Pencils

For professional art, design, drafting, and rendering on paper or vellum. Smooth-gliding, non-crumbling, durable, opaque graphite core. Hexagonal wood case with aluminum cap. 6B is the softest.

NUMBER	HARDNESS	EACH	12/EA	24/EA
A20406-2061	6B	\$1.37	\$1.23	\$1.17
A20406-2051	5B	1.37	1.23	1.17
A20406-2041	4B	1.37	1.23	1.17
A20406-2031	3B	1.37	1.23	1.17
A20406-2021	2B	1.37	1.23	1.17
A20406-2001	B	1.37	1.23	1.17
A20406-2030	HB	1.37	1.23	1.17
A20406-2101	F	1.37	1.23	1.17
A20406-2130	H	1.37	1.23	1.17
A20406-2022	2H	1.37	1.23	1.17
A20406-2032	3H	1.37	1.23	1.17
A20406-2042	4H	1.37	1.23	1.17
A20406-2052	5H	1.37	1.23	1.17
A20406-2062	6H	1.37	1.23	1.17
A20406-2072	7H	1.37	1.23	1.17
A20406-2081	8H	1.37	1.23	1.17
A20406-2092	9H	1.37	1.23	1.17

Prismacolor® Turquoise Pencil Sets

Designed for sketching, portrait, and precise figure drawing. Pure and smooth laydown in a wide variety of grades, the lead sharpens to a perfect point for a scratchless, glossy line in any weight. Available in two 12-pencil sets: Art for rough layouts, and Sketch for sketching and drawing techniques.



NUMBER	DESCRIPTION	EACH	6/EA
A20469-0129	Art Set	\$17.75	\$16.37
A20469-2129	Sketch Set	17.75	16.37

Prismacolor® Graphite Drawing Set

Prismacolor pure woodless graphite is a smooth drawing formula, with no wood casing to sharpen away. Create fine or broad strokes. The 18-piece set contains one each of Graphite 2B; Woodless Graphite 4B, 6B, and 8B; Water-Soluble Gray Graphite HB, 4B, and 8B; an extra-large kneaded eraser; a steel sharpener; a sanding board; and a Magic Rub eraser; and seven Turquoise drawing pencils from 8B to 6H in a convenient, easy-close metal box.



NUMBER	EACH	12/EA
A20492-2199	\$29.24	\$26.32

C Prismacolor® Ebony Layout Pencils

The artist's favorite for sketching, drawing, and layout. Thick, black, satiny-smooth graphite lead. Package of 12.

NUMBER	EACH	12/EA	24/EA
A20411-2009	\$8.19	\$7.37	\$6.99

D Tombow® MONO Professional Drawing Pencils

With its superior, extra-refined, high-density graphite, high point strength, break-resistance, and smearproof lines, the MONO Professional is the ultimate instrument for drawing and drafting. It contains the same lead as the MONO 100 — the gold standard among artists and animators.

NUMBER	HARDNESS	EACH	12/EA	24/EA
A20477-1006	6B	\$1.52	\$1.37	\$1.28
A20477-1004	4B	1.52	1.37	1.28
A20477-1002	2B	1.52	1.37	1.28
A20477-1000	B	1.52	1.37	1.28
A20477-1011	HB	1.52	1.37	1.28
A20477-1010	H	1.52	1.37	1.28
A20477-1012	2H	1.52	1.37	1.28
A20477-1014	4H	1.52	1.37	1.28
A20477-1016	6H	1.52	1.37	1.28

Set of 3 — Includes 4B, 2B, and HB.

NUMBER	EACH	6/EA
A20477-1039	\$4.59	\$4.13

Set of 6 — Includes 6B, 4B, 2B, B, HB, and 2H, plus a Mono Zero eraser.

NUMBER	EACH	6/EA
A20477-1069	\$11.79	\$10.62

Set of 12, Assorted — Includes 6B, 5B, 4B, 3B, 2B, B, HB, F, H, 2H, 3H, and 4H.

NUMBER	EACH	6/EA
A20477-0129	\$18.87	\$16.98

E Derwent® Watersoluble Pencils

Shade on dry paper and apply a water wash to achieve a watercolor look, or use dampened paper for softened edges of line. Or just use them dry like regular sketching pencils.

NUMBER	HARDNESS	EACH	12/EA
A20404-2050	HB (Lt. Wash-hardest)	\$1.82	\$1.69
A20404-2040	4B (Medium Wash)	1.82	1.69
A20404-2080	8B (Dark Wash)	1.82	1.69

F General's® Sketch & Wash Pencil

A watersoluble, soft, black graphite pencil. May be used wet or dry, or use it dry, then apply a water wash.

NUMBER	EACH	12/EA	24/EA
A20419-2001	\$1.37	\$1.24	\$1.17

G Faber-Castell® Graphite Aquarelle Pencils

Watersoluble graphite dissolves completely with a wet brush, leaving behind a soft wash of graphite that is waterproof when dry. Great for adding shading and depth to sketches, classical watercolor paintings, and mixed media applications.

NUMBER	HARDNESS	EACH	6/EA
A22251-1000	HB	\$2.95	\$2.54
A22251-1002	2B	2.95	2.54
A22251-1004	4B	2.95	2.54
A22251-1006	6B	2.95	2.54
A22251-1008	8B	2.95	2.54

Faber-Castell® Graphite Aquarelle Drawing Set

Five grades of aquarelle pencils, including 8B, 6B, 4B, 2B, HB, and a paintbrush.

NUMBER	EACH	5/EA
A22251-2005	\$13.04	\$11.66



H Faber-Castell® Goldfaber Graphite Sketching Pencils

Students and aspiring artists will enjoy using these high-quality, economically priced drawing pencils. The leads are made of finely ground graphite and clay, bonded to the casings for break-resistance.

NUMBER	HARDNESS	EACH	12/EA	24/EA
A20453-2161	6B	\$.99	\$.89	\$.84
A20453-2141	4B	.99	.89	.84
A20453-2121	2B	.99	.89	.84
A20453-2001	B	.99	.89	.84
A20453-2031	HB	.99	.89	.84
A20453-2131	H	.99	.89	.84
A20453-2021	2H	.99	.89	.84
A20453-2041	4H	.99	.89	.84

I Faber-Castell® Goldfaber Graphite Sketching Pencil Set

Six pencils (one each of 6B, 4B, 2B, B, HB, and 2H) in an attractive storage box, plus a metal sharpener and a dust-free plastic eraser.

NUMBER	EACH	6/EA
A20453-1009	\$9.15	\$8.25

J Faber-Castell® Art On The Go Drawing Set

Take this set of premium graphite pencils anywhere you go! Includes two each 6B, 4B, 2B, and HB, and one each 4H, 2H, H, and B, plus an eraser, pencil sharpener, and carry bag with swivel clip.

NUMBER	EACH	6/EA
A20493-1009	\$21.14	\$17.88

K Faber-Castell® School Pack

This convenient school pack holds 144 graphite pencils (24 each of 6B, 4B, 2B, B, HB, and H), plus 24 stainless steel pencil sharpeners.

NUMBER	EACH	6/EA
A20318-1449	\$149.68	\$134.71

L General's® Kimberly Drawing Pencils

Non-porous Ceylon graphite leads are dense, durable, and "Carbo-Welded" to withstand 4X the normal pressure. Cedar wood casings sharpen easily.

NUMBER	INDIVIDUAL	NUMBER	PACK OF 2	
A20421-2080	8B	A20458-2062	6B	
A20421-2071	7B	A20458-2052	5B	
A20421-2061	6B	A20458-2042	4B	
A20421-2051	5B	A20458-2032	3B	
A20421-2041	4B	A20458-2022	2B	
A20421-2031	3B	A20458-2102	B	
A20421-2021	2B	A20458-2302	HB	
A20421-2001	B	A20458-2202	F	
A20421-2030	HB	A20458-2402	H	
A20421-2101	F	A20458-2122	2H	
A20421-2020	H	A20458-2142	4H	
A20421-2022	2H	A20458-2152	5H	
A20421-2032	3H	A20458-2162	6H	
A20421-2042	4H			
A20421-2052	5H	EACH	12/EA	24/EA
A20421-2062	6H	\$2.17	\$1.95	\$1.85
A20421-2072	7H			
A20421-2081	8H			
A20421-2092	9H			
		NUMBER	INDIVIDUAL	
		A20421-2091	9XXB	
		EACH	12/EA	24/EA
		\$1.09	\$.98	\$.93
		EACH	12/EA	24/EA
		\$2.18	\$1.96	\$1.86

M General's® Solid Graphite Drawing Pencil Classroom Pack

Artist-quality pencils at a value price! This set of 144 drawing pencils includes soft, medium, and hard leads for art and classroom activities, three dozen each of 6B/4B, two dozen each of 2B/HB, and one dozen each of 2H/4H. Made in the USA.

NUMBER	EACH	6/EA
A21599-1066	\$74.99	\$67.49

N General's® Kimberly Drawing Pencil Sets

Set of four includes HB, 2B, 2H, Ebony Layout pencil, and a plastic eraser. Set of 10 includes 8B, 6B, 4B, 3B, 2B, B, HB, F, 2H, and 4H, plus an eraser and sharpener.

NUMBER	DESCRIPTION	EACH	6/EA	12/EA
A20421-1019	4-Piece	\$4.05	\$3.65	\$3.42
A20421-1009	10-Piece	9.21	8.29	7.87

O Kimberly® Graphite Classroom Art Pack™

Two dozen each of six hardnesses of General's Premium Kimberly pencils, one dozen each of two types of compressed graphite sticks, 24 erasers, 12 sharpeners, and a "Learn to Draw Now™" book.

NUMBER	EACH	6/EA
A20421-2009	\$206.35	\$185.70

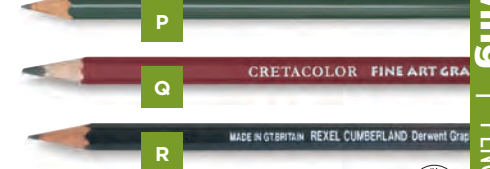

P Faber-Castell® 9000® Pencils

Since 1905, this top-quality pencil with superior black lead made of very finely ground graphite and clay has been a favorite of artists and draftsmen. For writing, drawing, and sketching, pencils are SV bonded for break-resistance, and coated with waterbased varnish. For set contents, visit DickBlick.com.

NUMBER	HARDNESS	EACH	12/EA	24/EA
A20450-1006	6B	\$1.87	\$1.67	\$1.58
A20450-1004	4B	1.87	1.67	1.58
A20450-2021	2B	1.87	1.67	1.58
A20450-2001	B	1.87	1.67	1.58
A20450-2030	HB	1.87	1.67	1.58
A20450-2130	H	1.87	1.67	1.58
A20450-2020	2H	1.87	1.67	1.58
A20450-2040	4H	1.87	1.67	1.58

NUMBER	DESCRIPTION	EACH	6/EA
A20450-0126	Drawing Set of 6	\$11.91	\$10.71
A20450-0129	Drawing Art Set of 12	20.56	18.82
A20450-9009	Drawing Design Set of 12	20.56	18.82

Q Cretacolor® Fine Art Graphite Pencils

These superior-quality traditional graphite pencils have a cedar casing for strength and sharpening ease. Softer grades produce broader and darker strokes; harder grades produce more precise and lighter strokes.

NUMBER	HARDNESS	EACH	12/EA	24/EA
A20497-3090	9B	\$1.65	\$1.48	\$1.41
A20497-3080	8B	1.65	1.48	1.41
A20497-3070	7B	1.65	1.48	1.41
A20497-3060	6B	1.65	1.48	1.41
A20497-3050	5B	1.65	1.48	1.41
A20497-3040	4B	1.65	1.48	1.41
A20497-3030	3B	1.65	1.48	1.41
A20497-3020	2B	1.65	1.48	1.41
A20497-3001	B	1.65	1.48	1.41
A20497-3000	HB	1.65	1.48	1.41
A20497-3100	F	1.65	1.48	1.41
A20497-3110				



A Blick® No. 2 Pencils

Prized for its tight wood grain, California Incense Cedar is regarded as the best wood for pencil production, which is why we make our No. 2 pencils from it! These smooth-sharpening pencils feature a hexagonal casing and a yellow enamel finish. Box of 12. Made in the USA.

NUMBER	EACH	12/EA	24/EA
A20341-4002	\$2.57	\$2.31	\$4.17

E Ticonderoga® No. 2 Pencils

Crafted from premium-grade wood from non-rainforest sources, these pencils make a powerful statement with their subtle matte black finish. An exclusive graphite core formula assures extra-smooth performance. A latex-free eraser makes easy, clean corrections. Box of 12.

NUMBER	EACH	6/EA
A20340-2029	\$4.62	\$4.16

B Paper Mate® Mirado Black Warrior Pencil



This premium round cedar pencil with a black matte finish lends a sophisticated look, while its straight woodgrain reduces friction during sharpening. A Pink Pearl eraser ensures clean corrections. Set of 12.

NUMBER	EACH	6/EA
A20346-2012	\$2.99	\$2.72

C Dixon™ Oriole Pencil

This is a first-rate, commercial-grade, wood-cased, pre-sharpened pencil at an economical price. Perfect for architects, engineers, and contractors — or anyone who needs a dependable pencil. Bonded for break-resistant writing with a high-quality pink eraser. No. 2; box of 12. Non-toxic.

NUMBER	EACH	6/EA
A20322-0012	\$3.18	\$2.86

D STAEDTLER® Yellow Pencil

These classic No. 2 graphite pencils are perfect for the classroom or your backpack! Pre-sharpened, with wood casings and latex-free eraser tips.

NUMBER	DESCRIPTION	EACH	6/EA
A20350-1019	Set of 12	\$2.79	\$2.51
A20350-1009	Set of 144	27.06	24.35

Paper Mate® Everstrong Break-Resistant Pencils

Get more out of your pencil with Paper Mate EverStrong No. 2 pencils! These woodcase pencils feature reinforced, break-resistant leads that require less sharpening and last longer. The pre-sharpened wood pencils have latex-free erasers. Set of 12.

NUMBER	EACH	6/EA
A22694-1012	\$3.99	\$3.61



F Ticonderoga® Laddie™ No. 2 Pencil

These slightly oversized (11/32") No. 2/HB pencils can help youngsters make the transition from printing to cursive writing easily and comfortably. These intermediate pencils have a thicker, round, real wood casing that makes them easy to grasp and easy to sharpen. They feature a thick graphite lead that delivers a smooth line to help form letters clearly, plus pink erasers to erase cleanly. Made from reforested wood. Non-toxic. Box of 12.

NUMBER	EACH	6/EA
A20300-1012	\$5.97	\$5.38

G Ticonderoga® Beginner's Pencil

This large, 13/32" diameter pencil is designed to help children learn and improve their printing and writing. Real wood sharpens easily. Box of 12.

NUMBER	EACH	6/EA
A20524-1012	\$6.99	\$6.29

H Ticonderoga® Pencils

"America's best pencil." Yellow hexagon-shaped pencils feature a smooth-writing #2 graphite core and a premium pink eraser. Box of 12.

NUMBER	DESCRIPTION	EACH	3/EA
A20305-2009	Unsharpened	\$3.89	\$3.50
A20305-1209	Sharpened	4.24	3.80

I Crayola® No. 2 Pencils

The most requested item on every kid's back-to-school list, No. 2 pencils are a school staple. Great for note-taking and test-taking, these pre-sharpened No. 2 pencils from Crayola have bright yellow barrels imprinted with the Crayola logo, and colored eraser tips that make erasing fun.

NUMBER	SET	EACH	12/EA
A20688-1019	20 Pencils	\$5.30	\$4.77



J General's® Layout Pencil

This versatile pencil is great for art, sketching, and layout work. The standard size, round pencil has very soft (6B equivalent), heavy, black graphite. Package of 12.

NUMBER	EACH	12/EA
A20412-2009	\$7.04	\$6.29

K Sharpie® China Wrapped Marker

Paper-wrapped marker (grease pencil) with thick, waxy core that marks on any surface — china, glass, metal, plastic, photographs, films, and more. Just pull the string and unwrap to expose more core.

NUMBER	COLOR	EACH	12/EA	24/EA
A22923-2001	Black	\$1.08	\$0.99	\$0.93
A22923-1001	White	1.08	.99	.93

L Dixon® Phano China Markers

Make bold strokes on almost any porous or non-porous surface including glass, plastic, film, paper, metal, and rubber. Marks are water-resistant and colorfast, but wipe clean from non-porous surfaces. Markers are paper-wrapped with a tear-string for easy sharpening — no need for a sharpener. Set of five includes Red, Yellow, White, and two Black markers. Non-toxic.

NUMBER	DESCRIPTION	EACH	6/EA	12/EA
A21598-1009	5 Assorted	\$3.76	\$3.38	\$3.21
A21598-2020	Black	.89	.81	.76
A21598-1020	White	.89	.81	.76

M Caran d'Ache® Grafwood Pencils

Explore the limitless possibilities of black with this series of extra-fine graphite pencils from Caran d'Ache. Fifteen gradations (including 9B, the deepest black graphite on the market) enable artists to produce an infinite range of techniques and effects. Easy-to-hold design offers optimal artistic control.

NUMBER	DESCRIPTION	EACH	6/EA	12/EA
A22700-1090	9B	\$4.14	\$3.73	\$3.54
A22700-1080	8B	4.14	3.73	3.54
A22700-1070	7B	4.14	3.73	3.54
A22700-1060	6B	4.14	3.73	3.54
A22700-1050	5B	4.14	3.73	3.54
A22700-1040	4B	4.14	3.73	3.54
A22700-1030	3B	4.14	3.73	3.54
A22700-1020	2B	4.14	3.73	3.54
A22700-1001	B	4.14	3.73	3.54
A22700-1000	HB	4.14	3.73	3.54
A22700-1100	F	4.14	3.73	3.54
A22700-1110	H	4.14	3.73	3.54
A22700-1022	2H	4.14	3.73	3.54
A22700-1032	3H	4.14	3.73	3.54
A22700-1042	4H	4.14	3.73	3.54



N Pentel® Sharp™ Pencils

The industry standard for drafting pencils, with a ribbed finger grip, adjustable pocket clip, and a fixed sleeve that prevents lead breakage. The eraser is protected by a cap. Includes six leads. Refill with Pentel Super Hi-Polymer lead. For more colors, visit DickBlick.com.

NUMBER	COLOR	SIZE	EACH	12/EA
A20603-7005	Green	0.5 mm	\$7.14	\$6.43
A20603-2615	Metallic Graphite	0.5 mm	7.14	6.43
A20603-9325	Metallic Silver	0.5 mm	7.14	6.43
A20603-5007	Blue	0.7 mm	7.14	6.43
A20603-2617	Metallic Graphite	0.7 mm	7.14	6.43
A20603-9327	Metallic Silver	0.7 mm	7.14	6.43



Hi-Polymer Lead Refills — Tube of 12.

NUMBER	SIZE	HARDNESS	EACH	12/EA
A20603-0521	0.5 mm	2B	\$1.33	\$1.19
A20603-0000	0.3 mm	HB	2.23	1.99
A20603-1005	0.5 mm	HB	1.33	1.19
A20603-1007	0.7 mm	HB	1.33	1.19
A20603-0093	0.9 mm	HB	1.33	1.19
A20603-0003	0.3 mm	H	2.23	1.99
A20603-0512	0.5 mm	H	1.33	1.19
A20603-0072	0.7 mm	H	1.33	1.19
A20603-0522	0.5 mm	2H	1.33	1.19

Hi-Polymer Colored Lead Refills — Tube of 12 HB leads. 0.5 mm.

NUMBER	COLOR	EACH	12/EA
A20603-3005	Red	\$1.78	\$1.61
A20603-5005	Blue	1.78	1.61



Eraser Refills — Package of three.

NUMBER	EACH	12/EA
A20603-1009	\$1.68	\$1.51

O Pentel® Twist-Erase® Click Mechanical Pencil

Pre-loaded with Pentel's Super Hi-Polymer® HB lead, the Twist-Erase Click produces a sharp, dark line. Other features include an extra-long, non-abrasive twist-up eraser; a smooth, latex-free Comfort-Zone® grip; a quick-click side advance button; and a metal pocket clip. Contains 59% recycled plastic.

NUMBER	COLOR	SIZE	EACH	12/EA
A20686-2025	Black	0.5 mm	\$3.34	\$2.99
A20686-2027	Black	0.7 mm	3.34	2.99
A20686-2029	Black	0.9 mm	3.34	2.99
A20686-5015	Blue	0.5 mm	3.34	2.99
A20686-5017	Blue	0.7 mm	3.34	2.99
A20686-5019	Blue	0.9 mm	3.34	2.99
A20686-6515	Violet	0.5 mm	3.34	2.99
A20686-6517	Violet	0.7 mm	3.34	2.99
A20686-6519	Violet	0.9 mm	3.34	2.99

new!

new!



P Pentel® GraphGear 500™ Pencils

This technical drafting pencil with an industrial design features a 4 mm fixed sleeve for template work and technical drawings. A metallic mesh grip on a slim, beveled barrel assures precision and control. Other features include a top-click, stationary eraser and tip. Lead and eraser are refillable.

NUMBER	SIZE	EACH	12/EA
A20672-8003	0.3 mm Brown	\$7.81	\$7.03
A20672-2005	0.5 mm Black	7.81	7.03
A20672-4807	0.7 mm Blue	7.81	7.03
A20672-2509	0.9 mm Gray	7.81	7.03

Q Pentel® GraphGear 1000™ Pencils

A superior drafting pencil for the professional. Finely chiseled metallic grip is inlaid with soft rubber pads for comfort. Dual-action retractor advances/retracts the pencil tip. Different accent color on each identifies the lead thickness.

NUMBER	SIZE	EACH	6/EA
A20654-2565	0.5 mm	\$24.79	\$22.32
A20654-9029	0.9 mm	24.79	22.32
A20654-5027	0.7 mm	24.79	22.32
A20654-8013	0.3 mm	24.79	22.32

R Pentel® Twist Erase Pencils

Superior-quality construction with a soft rubber grip, ergonomic barrel, and jumbo eraser that is larger than most. The barrel twists to advance and retract the eraser. Push down on the barrel to advance the lead. Uses Pentel Super Hi-Polymer lead, which is the world's strongest.

NUMBER	COLOR	SIZE	EACH	12/EA
A20752-7005	Green	0.5 mm	\$5.99	\$5.39
A20752-2025	Black	0.5 mm	5.99	5.39
A20752-5005	Blue	0.5 mm	5.99	5.39
A20752-6065	Violet	0.5 mm	5.99	5.39
A20752-1001	Eraser Refill		2.19	1.99

S NEW! Blick Studio Mechanical Pencils

Superior-quality construction for maximum precision. Features include a knurled, chrome-plated anti-slip grip, lead hardness indicator on the cap, and 4 mm fixed sleeve to prevent breakage. Includes eraser and metal clip. Comes pre-loaded with two pieces of HB lead. Available in 0.3 mm, 0.5 mm, 0.7 mm and 0.9 mm sizes.

NUMBER	COLOR	SIZE	EACH	12/EA
A26811-2023	Black	0.3 mm	\$7.69	\$6.92
A26811-2025	Black	0.5 mm	7.69	6.92
A26811-2027	Black	0.7 mm	7.69	6.92
A26811-2029	Black	0.9 mm	7.69	6.92

T NEW! Blick Studio Lead Holder

Featuring a knurled, chrome-plated anti-slip grip, this high-quality lead holder comes pre-loaded with one piece of 2 mm HB lead. Features include a lead hardness indicator, metal clip, drop clutch mechanism, and cap with a built-in sharpener.

NUMBER	COLOR	SIZE	EACH	12/EA
A26812-2022	Black	2 mm	\$9.99	\$8.98

U Alvin® Draft/Matic Pencils

Designed to provide maximum precision and convenience, this cushion-pointed mechanical pencil features non-slip, metal diamond-cut finger grips at top and bottom for control. Push-button cap provides continuous feed of up to 12 leads and also conceals a built-in eraser. A rotating window indicates degree of lead hardness. A 4 mm guide tube supports the lead and assures accuracy with even the thickest straightedges.

NUMBER	COLOR	SIZE	EACH	6/EA
A20622-4003	Yellow	0.3 mm	\$14.66	\$13.20
A20622-2025	Black	0.5 mm	14.66	13.20
A20622-5007	Blue	0.7 mm	14.66	13.20
A20622-3349	Maroon	0.9 mm	14.66	13.20

V Alvin® B/2 Lead Holder

A four-way clutch grip on this lead holder firmly holds 2 mm leads. Push-button lead advance; pocket clip. Barrel color may vary.

NUMBER	EACH	12/EA
A20626-0000	\$7.68	\$6.90

W Prismacolor® Turquoise Leads

Turquoise Leads — For use on paper or vellum. 5-1/8" L x .078" Dia (2 mm). Leads fit Turquoise holder and Tacro four-prong holder. Box of 12 leads of the same degree of hardness. 6B softest, 6H hardest. Tiny particles of electronic graphite provide denser, blacker, smoother writing leads.

NUMBER	HARDNESS	EACH	6/EA
A20601-2068	6H	\$15.38	\$13.84
A20601-2099	5H	15.38	13.84
A20601-2098	4H	15.38	13.84
A20601-2097	3H	15.38	13.84
A20601-2039	HB	15.38	13.84
A20601-2092	2B	15.38	13.84
A20601-2093	3B	15.38	13.84
A20601-2094	4B	15.38	13.84
A20601-2095	5B	15.38	13.84
A20601-2069	6B	15.38	13.84



Alvin® Rotary Lead Holder

Compact, 2-1/2"H x 1-3/8"Dia plastic body houses a rotary action sharpener suitable for all 2 mm leads. Automatic cutting stop and point cleaner.

NUMBER	EACH	12/EA
A21411-1025	\$12.97	\$11.66



A Blick® Matte Fixative

Our workable, mottle-free fixative is excellent for protecting pastel and charcoal drawings between layers of color. Rework and erase if desired. 12 oz (355 ml) can.

NUMBER	EACH	12/EA
A21707-1105 ■	\$8.40	\$7.56

B Blick® Gloss Fixative

A mottle-free acrylic spray that covers, protects, and prevents smudging. Several coats will produce a glossy, bright finish. 12 oz (355 ml) spray can.

NUMBER	EACH	12/EA
A21707-1005 ■	\$8.40	\$7.56

C Krylon® #1306 Workable Matte Fixatif

A clear, matte fixative that's easy to work with, Krylon #1306 dries in seconds and doesn't wrinkle, smudge, or smear. Lasting protection for pencil, charcoal, and chalk, yet erases easily. 11 oz (325 ml) can.

NUMBER	EACH	6/EA
A21703-1003 ■	\$8.98	\$8.07

D Krylon® #1311 Matte Finish

A permanent, non-gloss, clear finish that eliminates glossy sheen and light reflection on black and white or colored surfaces. Dries in minutes and gives a soft, satin finish to glossy photos and negatives. 11 oz (325 ml) can.

NUMBER	EACH	6/EA
A21703-1004 ■	\$10.89	\$9.80

E Krylon® Low Odor Clear Finish

Formulated with true latex technology, Krylon Low Odor Clear Finish provides the same quality as traditional Krylon coatings. 11 oz (325 ml) cans.

NUMBER	DESCRIPTION	EACH	12/EA
A23710-1001 ■	Gloss	\$10.17	\$9.16
A23710-2001 ■	Matte	10.17	9.16

F Krylon® #1323 Satin Finish Fixative

Krylon Satin Finish provides a permanent, protective satin finish that will not yellow with age. Moisture-resistant and smudgeproof, it dries fast and clear for protection of artwork, crafts, and valuables from dirt and discoloration. 11 oz (325 ml) can.

NUMBER	EACH	6/EA
A21703-1007 ■	\$10.89	\$9.80

G Winsor & Newton™ Artists' Fixative Spray

Winsor & Newton Artists' Fixative Spray provides a non-removable, colorless, and transparent finish. It can be used on charcoal, pencil, pastel, and chalk drawings. The aerosol spray can contains no fluorocarbons. 13.5 oz (400 ml).

NUMBER	EACH	12/EA
A21711-1002 ●	\$14.10	\$12.69

H Blair® Spray Coatings

Create a clear, super-hard, permanent barrier that protects your artwork against stains, moisture, and environmental pollutants. Use on paper, wood, ceramics, plaster, photographs, leather, and more. Gloss or matte finish. 11.75 oz (347 ml) cans.

NUMBER	DESCRIPTION	EACH	12/EA
A21704-0000 ■	Gloss	\$13.07	\$11.76
A21708-9006 ■	Matte	13.07	11.76

I Blair® Matte Spray Fixative

This workable matte fixative offers smudge-proof protection for pencil, charcoal, pastel, and chalk and stops bleeding between layers of tempera, casein, and watercolors. Easily removed with mineral spirits. 12 oz (355 ml) spray can.

NUMBER	DESCRIPTION	EACH	6/EA
A21702-0000 ■	Spray Fix	\$12.63	\$11.37
A21708-1002 ■	Very Low Odor Spray Fix	12.95	11.65

J Lascaux® Fine Art Fixative

Fixes or seals virtually everything — pastels, pencil, charcoal, crayon, ink, gouache, or watercolor. Won't yellow, resists aging, and is non-matte. Use on photos, prints, lithographs, proofs, lettering, and gold leaf to make them scratch-resistant. Makes an excellent initial sizing on wood panels and other rigid supports. Contains no fluorocarbons. 12 oz (355 ml) can.

NUMBER	EACH	12/EA
A21714-0300 ■	\$31.94	\$28.75

K Sennelier® Delacroix Spray Fixative for Pencils & Charcoals

Created especially for protecting pencil and charcoal renderings, this non-yellowing fixative spray made from synthetic resin and alcohol dries to a uniform, transparent matte finish. For best results, apply in several light coats. Not intended for use on soft pastel drawings. 13.5 oz (400 ml) spray can.

NUMBER	EACH	6/EA
A21712-1400 ■	\$18.73	\$16.86

L Sennelier® HC10 Universal Fixative

Made from protective acrylic resin, this universal fixative won't alter the appearance of your work. It adapts to most mixed media techniques with pastels, charcoal, watercolors, inks, acrylics, photos, and block-out/surface preparations, and can be used for priming paper, canvas, wood, glass, ceramic, porcelain, and walls, or as an adhesive. Highly lightfast, non-yellowing, and water-resistant. 360° cap/nozzle design aids accuracy and minimizes overspray. Choose a horizontal or vertical spray pattern. 13.5 oz (400 ml) spray can.

NUMBER	EACH	6/EA
A21732-1013 ●	\$29.66	\$26.70

M Sennelier® Latour Spray Fixatif for Soft Pastels

Use this resin and alcohol-based solution to protect soft pastel drawings and seal them to the support. Transparent and non-yellowing, this matte spray fixative won't alter subtle pastel hues. Repeated light applications are recommended for maximum protection against smearing. 13.5 oz (400 ml) spray can.

NUMBER	EACH	6/EA
A21700-9000 ■	\$18.73	\$16.86



Alvin® 300 Hardwood Pantograph

Use this 21" long pantograph with inclined or horizontal boards for tracing or dotting. It features die-sunk graduations with drilled holes for accuracy, and adjustable nylon ratio thumb screws for smooth movement. Nicked lead holder attachment and table clamps; nylon tracer point. Includes accessories and instructions.

NUMBER	EACH	4/EA
A55666-1021	\$53.74	\$48.37

Gray Paper Stumps

These stumps are made of tightly spiral-wound, soft gray paper. Each stump is 5" long with points on both ends. Use for smoothing and blending large areas of pastel or charcoal. Each package contains 12 stumps.

NUMBER	DIA	LENGTH	EACH	12/EA	24/EA
A22943-1012	1/8"	4-1/2"	\$2.90	\$2.61	\$2.49
A22943-1112	5/16"	5"	3.66	3.29	3.13
A22943-1212	3/8"	5"	4.99	4.49	4.27
A22943-1312	7/16"	5-3/4"	5.83	5.25	4.99

Set of 12 — Includes three of each size listed above.

NUMBER	EACH	12/EA	24/EA
A22943-1412	\$4.17	\$3.75	\$3.56

Class Pack — Large volume users get a price break with class packs. This 48-piece set includes 12 each of 1/8", 5/16", 3/8", and 7/16" diameter stumps.

NUMBER	EACH	3/EA	6/EA
A22856-1048	\$17.46	\$15.72	\$14.84



Tortillons

Use tortillons for smoothing and blending pastels and charcoal, and for detailed stumping. Spiral-wound with one pointed end. Small: 2-3/4"L x 3/16"Dia. Medium: 3-1/4"L x 1/4"Dia. Large: 3-3/4"L x 5/16"Dia. 12-packs.

NUMBER	SIZE	EACH	12/EA	24/EA
A22942-1212	Small	\$1.20	\$1.08	\$1.03
A22942-1112	Medium	1.20	1.08	1.03
A22942-1012	Large	1.42	1.37	1.30

Class Pack — Large volume users get a price break with class packs. This 36-piece set includes 12 each of 3/16", 1/4", and 5/16" diameter tortillons.

NUMBER	EACH	3/EA	6/EA
A22855-1036	\$3.27	\$2.94	\$2.77



Spectrum Noir™ Pencil Blending Kit

Create stunning blending effects with these essential accessories. The set includes six sizes of blending stump, a sanding paddle (with 12 sheets of sandpaper), two sketching pencils, a double-hole pencil sharpener, and a soft eraser, in a zippered case. The different stump sizes allow blending and shading of the smallest details to the broadest backgrounds. For use with Spectrum Noir ColourBlend pencils and other dry media. Case measures 1-1/2" x 3-1/2" x 11".

NUMBER	EACH	12/EA
A04847-1009	\$17.63	\$15.87



Koh-i-Noor® Pencil Lengthener

Use almost every bit of a pencil before throwing it away! This sliding-grip holder holds both round and hexagonal pencils securely in its nickel-plated ferrule.

NUMBER	EACH	12/EA
A22922-0000	\$5.13	\$4.62



Cretacolor® Marbled Pencil Holder/Lengthener

An elegant-looking white/silver marbled handle for gripping even the shortest pencils. A metal slip tightener holds pencils in place. Use with 5/16" diameter woodless pencils.

NUMBER	EACH	12/EA
A22959-1000	\$6.52	\$5.85

Cretacolor® Metal Pencil Cap

Protects fine, 5/16" diameter woodless pencils. Also prevents unwanted markings and breakage, and extends pencil life.

NUMBER	EACH	12/EA
A22959-0000	\$1.56	\$1.40



Sandpaper Block

The simple way to keep a point on difficult-to-sharpen drawing pencils, charcoal, pastels, or crayons. Includes 12 sheets of 1" x 4" fine sandpaper, padded and mounted on a wood block.

NUMBER	EACH	12/EA	24/EA
A21517-1000	\$1.04	\$0.94	\$0.89



Alvin® Heritage™ Drawing Set

Great for use with pastels, charcoal, and graphite, this set includes a sandpaper pointer, a kneadable eraser, an erasing shield, tortillons, paper stumps, and a chamois.

NUMBER	EACH	6/EA
A22731-1009	\$11.88	\$10.68



Westcott® C-Thru Erasing Shield

Ideal for erasing small areas with precision and control. Made of 0.005" thick flexible stainless steel, each shield includes 26 open shapes for masking drawing and drafting work.

NUMBER	SIZE	EACH	6/EA
A21583-1001	2-3/4" x 5-1/2"	\$2.07	\$1.86



Creativity Street® Self-Portrait Mirrors

These durable, scratch-resistant, acrylic mirrors give every beginning artist a real, live model — yourself! Perfect for classroom portrait projects, these mirrors stand safely and steadily on any tabletop, reflecting clearly as you sketch, paint, or draw. They're also helpful as visual aids for speech therapy. Choose from a self-standing single mirror for individual use or a double-sided mirror that can be used by two artists at the same time. Mirrors measure 8-1/2" x 11".

NUMBER	DESCRIPTION	EACH	6/EA
A22810-0851	Single-Sided Mirror	\$11.62	\$10.46
A22810-8511	Double-Sided Mirror	17.66	15.99



Chamois

Soft and pliable, this chamois is excellent for blending and smudging, or for adding and removing color. Approximately 5" x 7".

NUMBER	EACH	12/EA	24/EA
A03462-1001	\$6.58	\$5.92	\$5.63



Latex Finger Cots

Use these comfortable, durable cots to protect your fingertips from cuts, paint, or to cover existing cuts and abrasions. Pack of 144.

NUMBER	SIZE	EACH	6/EA	12/EA
A35207-1001	Small	\$10.99	\$9.89	\$9.40
A35207-1002	Medium	10.99	9.89	9.40
A35207-1003	Large	10.99	9.89	9.40



Westcott® Wooden Dusting Brush

Ideal for removing fibers, dust, and eraser bits from drawings without smudging. The 2" long fine-quality horsehair bristles are set in a lacquered wood handle with a hang hole.

NUMBER	EACH	12/EA
A21578-1001	\$6.22	\$5.60

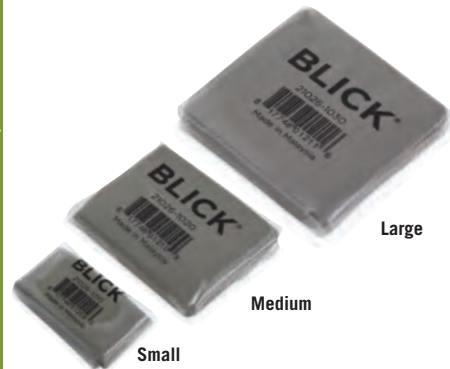

Blick® Kneaded Erasers

These pliable erasers are easy to knead into any shape for precise removal of charcoal, pastel, chalk, and pencil marks. Latex-free and PVC-free.

NUMBER	DESCRIPTION	SIZE	EACH	12/EA	24/EA
A21026-1010	1/4" x 3/4" x 1-1/4"	Small	\$.63	\$.54	\$.51
A21026-1020	1/4" x 1-1/4" x 1-3/4"	Medium	.74	.71	.68
A21026-1030	1/4" x 2-1/4" x 2-1/4"	Large	.86	.78	.74



Prismacolor® Kneaded Rubber Eraser

Kneads easily into any shape, erases cleanly, and picks up all residue. Excellent for removing or highlighting pencil, chalk, charcoal, and pastel.

NUMBER	SIZE	EACH	12/EA	24/EA
A21502-2620	1-1/4" x 3/4" x 1/4"	\$.80	\$.68	\$.65
A21502-2820	1-3/4" x 1-1/4" x 1/4"	.94	.90	.86
A21502-2720	2-1/8" x 2-1/8" x 3/8"	1.77	1.43	1.36



General's® Kneaded Eraser

Available in three sizes, these kneaded erasers are latex-free, lanolin-free, and PVC-free.

NUMBER	SIZE	EACH	6/EA	12/EA
A21587-1001	1-3/16" x 9/16" x 1/4"	\$.66	\$.59	\$.56
A21587-1002	1-3/4" x 1-1/8" x 1/4"	1.54	1.38	1.31
A21587-1003	1-15/16" x 1-15/16" x 1/4"	1.95	1.76	1.67



Tombow® MONO Colored Pencil Eraser

Made from natural rubber latex and silica grit, this eraser removes colored pencil and ink marks, including ballpoint, rollerball, and some marker ink. It's also useful for creating highlights in artwork. Produced using natural materials, including a 100% recycled pulp sleeve. 2-5/8" x 5/16" x 5/8".

NUMBER	EACH	6/EA
A21589-1002	\$.58	\$.53



Dixon® Pencil Top Erasers

Replace worn-out pencil erasers with soft wedge-shaped caps. Box of 144.

NUMBER	EACH	12/EA
A21513-2144	\$.93	\$.82



Soft Pink Beveled Eraser

Beveled on two ends for erasing pencil lines. Medium: 2-3/8" x 3/4" x 3/8". Large: 2-5/8" x 1" x 3/8". Box of 12.

NUMBER	SIZE	EACH	12/EA	24/EA
A21536-1040	Medium	\$6.05	\$5.45	\$5.10
A21536-1060	Large	7.25	6.53	6.19



Paper Mate® Pink Pearl® Eraser

Our best-selling pencil eraser, the Pink Pearl is a soft, pliable eraser that's beveled on both ends for better control while making smudge-free erasures. Box of 12.

NUMBER	SIZE	EACH	12/EA	24/EA
A21518-3052	2" x 3/4" x 3/8"	\$7.12	\$6.41	\$6.09
A21518-3050	2-1/4" x 7/8" x 7/16"	8.47	7.62	7.24
A21518-3051	2-15/32" x 1" x 3/8"	8.64	7.78	7.39



Tombow® MONO Dust Catch Eraser

Catch eraser dust as you erase with this tacky polymer eraser from Tombow. Residue sticks to the eraser, preventing small eraser bits from being left behind to damage illustrations, designs, or technical drawings. A protective paper sleeve with rounded edges keeps the eraser from being damaged during use. Phthalate-free and latex-free. 2-1/5" x 9/10" x 2/5".

NUMBER	EACH	20/EA
A21033-1001	\$1.75	\$1.57



Tombow® MONO Smart Eraser

This ultra-slim white plastic eraser is only 5.5 mm wide, perfect for tight areas and precision erasing. Its slim design fits inside planner pockets, journals, and personal calendars. A paper sleeve with rounded corner edges keeps the eraser from being damaged during use. Phthalate-free and latex-free. 2-3/5" x 7/10" x 1/5".

NUMBER	EACH	20/EA
A21034-1001	\$1.74	\$1.57



Alvin® Vinyl Eraser

White vinyl for erasing pencil from paper, vellum, and drafting film. Block in cardboard sleeve. 2-1/2" x 7/8" x 1/2".

NUMBER	EACH	20/EA
A21002-1000	\$1.09	\$.98



Blick® Soap Eraser

"Washes" away pencil lines! A school favorite.

Small Size — 1" x 1" x 5/8". Box of 24.

NUMBER	EACH	6/EA	12/EA
A21519-1024	\$6.15	\$5.49	\$5.22

Large Size — 2" x 1" x 5/8". Box of 12.

NUMBER	EACH	6/EA	12/EA
A21519-1012	\$6.15	\$5.49	\$5.22



General's® Factis Soap Erasers

These oval, all-purpose white soap erasers won't crumble or crack. Use them to erase charcoal, graphite, or pastel marks. Latex-free.

NUMBER	SIZE	EACH	12/EA
A21505-0000	2-1/2" x 1-1/8"	\$1.13	\$1.03
A21505-1001	2-5/8" x 1-1/2"	2.03	1.82



General's® Factis® Extra Soft White Eraser

This super-soft eraser erases pastels and charcoal, and even cleans watercolor paper without roughing or abrading it. Picks up its own shavings. 2-1/4" x 15/16" x 1/2" in a cardboard sleeve.

NUMBER	EACH	20/EA
A21508-0000	\$.90	\$.81



General's® Factis® Magic Black™ Eraser

Just like the original, the Factis Magic Black Eraser is super-soft, easy to use, and ideal for erasing charcoal and graphite. 1-5/8" x 1".

NUMBER	EACH	18/EA
A21504-2000	\$.84	\$.77

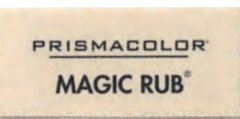

Prismacolor® Magic Rub® Eraser

Use this ivory-colored vinyl eraser on polyester-based drafting film, acetate, and tracing paper. 2-1/4" x 1" x 7/16". Box of 12.

NUMBER	EACH	12/EA	24/EA
A21510-1012	\$11.80	\$10.62	\$10.09



Pentel® Hi-Polymer Erasers

These high-quality, latex-free erasers and eraser caps remove graphite marks cleanly and easily with very little pressure. The block style is perfect for getting into corners or erasing large areas with no smudges, no paper tears, and no ghosting. Small erasers measure 5/8" x 1-5/8" x 7/16". The eraser caps fit snugly onto pencils. The 6-pack includes one small block eraser, one large block eraser, and four eraser caps. The XL eraser measures 1-3/4" x 4-1/4" x .93".

NUMBER	DESCRIPTION	EACH	12/EA
A21590-1021	Erasers, 3-Pack	\$1.99	\$1.78
A21590-1069	Erasers, 6-Pack	3.77	3.38
A21590-1025	Erasers, 15-Pack	6.21	5.59
A21577-1010	Caps, 10-Pack	2.21	1.98
A21577-1024	Caps, Class Pack of 240	55.61	50.05
A21590-1022	XL Eraser	5.50	4.95



Pentel® Hi-Polymer Colored Erasers

Remove graphite marks cleanly and easily with these colorful block-style erasers from Pentel. Ideal for getting into corners or erasing large areas quickly, they leave no smudges, no ghosting, and won't tear paper. They also won't crack or harden with age, remaining soft and easy to use. Latex-free. Pack of six. Erasers measure 11/16" x 7/16".

NUMBER	EACH	12/EA
A21596-1006	\$5.84	\$5.25



Derwent® Battery-Operated Eraser

This heavy-duty cordless eraser is great for erasing, refining, and creating effects in your drawings. It has a top-mounted power button and a sleek, ergonomic case that is ideal for both right-handed and left-handed users. The long-lasting erasers are easy to replace. Includes eight replacement erasers. Requires two AAA batteries (not included).

NUMBER	DESCRIPTION	EACH	12/EA
A21575-9330	Battery-Operated Eraser	\$15.69	\$14.12
A21575-1030	30 Eraser Refills	4.45	3.99



STAEDTLER® Retractable Triangular Eraser

A triangular shape makes this eraser pen comfortable to hold, while a push-button mechanism makes it easy to advance the eraser as needed. Use this latex-free, PVC-free eraser for erasing graphite marks on paper.

NUMBER	DESCRIPTION	EACH	12/EA
A22364-1001	Eraser Pen	\$2.76	\$2.48
A22364-1002	2-Pack Refill	1.12	.99



STAEDTLER® Mars® Plastic Erasers

These superior-quality soft white erasers remove graphite marks cleanly and completely from paper, vellum, and drafting film. Block eraser measures 2-1/2" x 7/8" x 1/2" and includes a sleeve for easy handling.

NUMBER	DESCRIPTION	EACH	12/EA
A21500-0000	Block Eraser	\$1.93	\$1.73
A21500-0002	Stick Eraser	3.50	3.14



Sakura® Cordless Eraser

Compact and easy to use, this battery-operated eraser weighs only 2.4 oz, including the batteries. It comes with 20 pencil erasers, plus two AAA batteries.

NUMBER	DESCRIPTION	EACH	6/EA
A21514-0000	Eraser	\$55.11	\$49.60
A21514-1080	Box of 60 Refills	10.46	9.42



Maped® Pencil Eraser

Made from an ultra-powerful material that easily removes even the darkest graphite marks from paper, vellum, and drafting film with minimal pressure — and without scratching, tearing, or smudging. PVC-free and latex-free, this eraser is soft and non-abrasive. 1/4" x 3/4" x 2-1/4".

NUMBER	EACH	20/EA
A21008-1042	\$1.20	\$1.08



Tombow® MONO Zero Eraser

Protect your work and erase only what you need with a high-quality, precision eraser that won't damage your paper. With tips in two shapes and sizes, the refillable MONO Zero has a pen-style body that's easy to use and store — or use the convenient clip for on-the-go corrections.

NUMBER	DESCRIPTION	EACH	5/EA
A21576-9330	Round, Silver Barrel	\$5.21	\$4.69
A21576-2050	Rectangular, Black Barrel	5.21	4.69

Eraser Refill

NUMBER	DESCRIPTION	EACH	5/EA
A21576-1010	Round	\$2.28	\$1.99
A21576-1020	Rectangular	2.28	1.99



Tombow® MONO Knock Stick Eraser

With a pen-style body, a rubber grip for comfort, and a convenient clip, the MONO Knock Stick Eraser is great for on-the-go corrections. Push-button action advances the 3-4/5" diameter eraser.

NUMBER	DESCRIPTION	EACH	12/EA
A21020-7010	Green	\$2.19	\$1.98
A21020-1004	Refill Pack of 4	2.19	1.98



Faber-Castell® Perfection Eraser Pencil with Brush

Ideal for fine-point erasing of liquid ink, waterbased ink, ballpoint ink, black-lead pencils, and charcoal, the Perfection Eraser Pencil has a brush that gently sweeps away eraser dust. Sharpen with a standard pencil sharpener.

NUMBER	EACH	12/EA
A21572-9000	\$3.36	\$2.99



General's® Factis® Mechanical Eraser

Remove charcoal, graphite, and pastel marks cleanly without crumbling or cracking. Made from soft, artist-quality plastic, this non-abrasive eraser is encased in a retractable holder, ideal for precise, fine-detail erasing. Latex-free. Made in Spain.

NUMBER	DESCRIPTION	EACH	12/EA
A21597-2020	Click Eraser	\$5.50	\$4.95
A21597-1003	Eraser Refills, 3-pack	3.43	3.09



Helix® Auto Eraser

Compact and easy to use, this battery-operated eraser works on pencil and ink. Includes eight pencil refills and two ink refills. Uses two AA batteries (not included).

NUMBER	DESCRIPTION	EACH	5/EA
A21554-0000	Eraser	\$13.06	\$11.76
A21554-1030	Eraser Refills, 30-ct	2.39	2.15



A Blick® Pencil Sharpener
This high-quality pencil sharpener features a high-carbon steel blade for precise sharpening and a small size that makes it ideal for travel. The shavings container is easy to clean.

NUMBER	EACH	12/EA	24/EA
A21460-1001	\$4.31	\$3.88	\$3.69

B Blick® Long Point Pencil Sharpener
The Blick Long Point Pencil Sharpener features two 8 mm sharpeners — one for sharpening the wood casing, and the second for sharpening the graphite lead to a long, precise point.

NUMBER	EACH	12/EA
A21461-1001	\$8.17	\$7.36

C Maped® Hand-Held Sharpener
All metal with two holes for both standard and large pencils. Also handy for careful sharpening of charcoal, pastels, and colored pencils.

NUMBER	DESCRIPTION	EACH	12/EA	24/EA
A21416-1000	Single Hole	\$.96	\$.87	\$.82
A21416-1002	Double Hole	2.41	2.16	2.06

D Dahle® Canister Sharpener
This hand-held pencil sharpener has two holes, one for standard size 8 mm pencils, and the other for 10.5 mm pencils. Its clear plastic shavings holder is easily removed for cleaning. 2-1/4"H x 1-3/8"Sqr.

NUMBER	EACH	10/EA	20/EA
A21407-1002	\$6.13	\$5.51	\$5.23

E Maped® Canister Pencil Sharpeners
These ergonomically shaped metal pencil sharpeners come in single-hole and double-hole styles. Each is encased in a durable plastic housing.

NUMBER	DESCRIPTION	EACH	12/EA
A21431-1001	Single Hole	\$1.91	\$1.70
A21427-1018	Double Hole	2.64	2.34

F General's® All Art Pencil Sharpener
Use this versatile sharpener with charcoal pencils, pastel pencils, and other soft core pencils. The sharpener is plastic and features a stainless steel blade that restores pencils to a factory point.

NUMBER	EACH	12/EA
A21424-1010	\$1.04	\$.93

Sav-a-Point Kit — Set of five plastic pencil point protectors, with bonus All Art sharpener.

NUMBER	EACH	12/EA
A21475-1059	\$3.30	\$2.97

G STAEDTLER® Pencil Grip™ Two-Hole Pencil Sharpener
Ideal for sharpening both standard and jumbo wood-cased pencils and colored pencils, this sharpener features all-metal sharpeners, a removable shavings container, and a lid. The blades are attached at three points for greater sharpening precision, and a special cutout makes removal of broken leads quick and easy.

NUMBER	EACH	12/EA
A21487-1001	\$6.53	\$5.88

H Faber-Castell® Grip Trio Sharpener
Three sharpeners in one! Perfect for keeping triangular Faber-Castell Jumbo Grip and Art Grip pencils sharp as well as standard graphite pencils, this three-hole sharpener keeps shavings neatly contained in two separate reservoirs.

NUMBER	EACH	12/EA
A21430-1001	\$6.05	\$5.45

I Mobius & Ruppert Brass Grenade Pencil Sharpeners
Virtually unbreakable, these ergonomic brass pencil sharpeners are a favorite of design professionals and artists. Choose single or double-hole design. Made in Germany.

NUMBER	DESCRIPTION	EACH	12/EA
A21413-1040	Single Hole	\$6.54	\$5.89
A21413-1020	Double Hole	10.84	9.74

J Mobius & Ruppert Brass Wedge Pencil Sharpeners
Built for heavy-duty use, these brass pencil sharpeners are virtually unbreakable. Choose single-hole or double-hole design. Made in Germany.

NUMBER	DESCRIPTION	EACH	12/EA
A21413-1010	Single Hole	\$6.54	\$5.89
A21413-1030	Double Hole	8.64	7.77

K NEW! Dux Glass Inkwell Sharpeners
An elegant addition to any workspace, these 2" x 2" sharpeners are suitable for round, hexagonal, and triangular standard-width pencils or crayons. A sturdy glass inkwell-shaped receptacle catches shavings.

NUMBER	COLOR	EACH	10/EA
A81420-5010	Blue	\$10.99	\$9.89
A81420-1010	Clear	10.99	9.89
A81420-7010	Green	10.99	9.89
A81420-3010	Red	10.99	9.89

L Bostitch® Twist-n-Sharp™ Pencil Sharpener
Sharpen pencils to the perfect point or blunt tip with a few twists of the wrist. The Twist-n-Sharp has a ratchet mechanism that makes manual sharpening quick and effortless for artists of all ages, plus its compact size is perfect for tucking into a backpack or travel bag. Tip Saver Technology™ prevents over-sharpening, an adjustable knob allows for two tip types, and an easy-to-clean built-in shavings tray reduces mess. Three bright and trendy translucent colors (we choose).

NUMBER	EACH	6/EA
A04848-1001	\$2.82	\$2.54

BLICK SHIPS QUICK — our reputation for industry-leading shipping times means you'll have it fast!



M Bostitch® QuietSharp™ Executive Electric Pencil Sharpener
Classroom-safe and durable, this sharpener has a unique angled cutter for controlled sharpening, and an easy-clean shavings receptacle. It is 65% faster with a 6X longer cutter life. Auto-stop prevents over-sharpening. Unit will not operate when blades are exposed. Includes a seven-year limited warranty.

NUMBER	EACH	3/EA
A21448-1001	\$36.12	\$32.52

N X-Acto® Ranger #55 Sharpener
X-Acto's finest manual pencil sharpener. Built with strong, double-bearing, all-metal construction, this sharpener handles the heaviest workloads. The adjustable pencil guide sharpens a wider selection of pencils. Features an extra-large hinged swivel receptacle and twin steel cutters with 30 cutting edges. Weighing a rugged 1.68 lb, it's practically indestructible! Wall or desk mount.

NUMBER	EACH	6/EA
A21410-1055	\$40.64	\$37.45

O Duet™ Battery-Operated/Manual Pencil Sharpener
Don't fret if quiet is needed — the Duet Pencil Sharpener toggles easily from battery to manual mode. With a sturdy yet stylish design, this sharpener fits perfectly in any classroom, office, or household. The sharpener works equally well with graphite and colored pencils, and super-gripping feet keep it firmly in place during use. Two AA batteries (not included) are required for battery operation.

NUMBER	EACH	12/EA
A21485-2020	\$10.57	\$9.51

P Bostich® QuietSharp 6™ Pencil Sharpener
Extend pencil life and cut down on sharpener noise. The QuietSharp 6 features 70% faster sharpening and 10 times longer cutter life. Includes a seven-year limited warranty.

NUMBER	EACH	4/EA
A21453-1001	\$61.46	\$55.88

Q X-Acto® Mighty Mite Electric Pencil Sharpener
This compact sharpener has a modern gear-box design with non-skid rubber feet for maximum precision, power, durability, and efficiency. Pencil Saver technology prevents over-sharpening both pencils and colored pencils. Its SafeStart Motor that stops when shavings bin is removed.

NUMBER	EACH	6/EA
A21423-2020	\$31.75	\$28.57

R X-Acto® Mighty Pro Electric Pencil Sharpener
This sharpener has an auto-adjust dial that works with all pencil sizes, and its LED light indicates when the pencil is perfectly sharpened. Its XL shavings bin creates less mess, and SmartStop technology prevents over-sharpening.

NUMBER	EACH	3/EA
A81405-2020	\$201.36	\$181.23

S X-Acto® Powerhouse Electric Pencil Sharpener
The X-Acto Powerhouse Electric Pencil Sharpener has an innovative vertical design that allows users to see the cutters. It features a Pencil Saver that prevents over-sharpening and a SafeStart Motor that stops when the shavings bin is removed. Optimized to sharpen colored pencils, the SafeStart Motor stops when the shavings bin is removed.

NUMBER	EACH	6/EA
A21412-1001	\$45.40	\$40.86

T X-Acto® School Pro Electric Pencil Sharpener
Ideal for classrooms, this sharpener features a dial with six holes to fit most pencils. It also has a break-resistant Fly-Away Cutter that stops when pencils are perfectly sharpened and a SafeStart Motor that won't sharpen pencils unless the shavings bin is in place.

NUMBER	EACH	6/EA
A81406-2020	\$59.68	\$53.71

U X-Acto® Teacher Pro Electric Pencil Sharpener
The Teacher Pro features an LED light that lets users know when pencils are perfectly sharpened. SmartStop technology prevents over-sharpening. It also has an Auto-Adjust Dial for sharpening pencils of all sizes, a large shavings bin, and a SafeStart feature to keep the motor from starting until the shavings receptacle is in place.

NUMBER	EACH	6/EA
A81408-2020	\$69.79	\$62.81

V X-Acto® XLR Electric Pencil Sharpener
This colored pencil-compatible sharpener has a Pencil Saver feature to prevent over-sharpening. The medium-size shavings bin is easy to empty, and the SafeStart Motor turns off the sharpener when the bin is removed.

NUMBER	EACH	6/EA
A81407-2020	\$36.33	\$32.70

W Westcott® iPoint® Manual Pencil Sharpener
This trendy sharpener is as practical as it is stylish. Armed with antimicrobial protection, the iPoint is a manual sharpener that resists stains and odor-causing bacteria, ideal for classroom settings. Features include titanium bonded dual helical blades that stay sharp longer, an adjustable dial with eight settings, and an EZ-view shavings reservoir. Includes a tabletop attachment and screw-down mounting. One-year manufacturer's warranty.

NUMBER	EACH	12/EA
A04845-1001	\$21.73	\$19.54



Blick® Manikins
Manikins are indispensable reference tools for learning the basics of figure drawing. Rendered from durable hardwood with a smooth, glossy finish, Blick Figure Manikins come in a variety of sizes, both male and female. Accurately proportioned and easy to pose, each has its own stand.

NUMBER	DESCRIPTION	EACH	6/EA
A21651-1001	5-1/2" Male	\$6.03	\$5.42
A21651-1002	8" Male	6.60	5.93
A21651-1004	12" Female	6.77	6.09
A21651-1003	12" Male	6.77	6.09
A21651-1006	16" Female	13.42	12.08
A21651-1005	16" Male	13.42	12.08

Blick® Hand Manikins
Hand Manikins — These expressive, accurately proportioned hand manikins have fully posable fingers. Two sizes. Choose Left or Right.

NUMBER	DESCRIPTION	EACH	6/EA
A21650-1003	10" Left	\$17.37	\$15.62
A21650-1004	10" Right	17.37	15.62
A21650-1001	12" Left	18.53	16.67
A21650-1002	12" Right	18.53	16.67



Family Manikin Set
These accurately proportioned, unfinished hardwood figures can be adjusted to assume almost any position. Includes a female figure (7-1/2" tall), a male figure (8" tall), and a gender-neutral, child-sized figure (5" tall). All three share the same stand.

NUMBER	DESCRIPTION	EACH	12/EA
A21648-1009		\$16.16	\$14.54



Art History Heroes Figurine Collection
Today Is Art Day turns history's celebrated artists into action figures that educate with fascinating trivia and true-to-the-past accessories. Each Art History Heroes Figurine is made of PVC, measures 5" tall, and includes a display base and 10 trivia facts about the artist's life and work.

NUMBER	DESCRIPTION	EACH
A80884-1007	Claude Monet	\$31.90
A80884-1006	Frida Kahlo	31.90
A80884-1005	Gustav Klimt	31.90
A80884-1004	Leonardo Da Vinci	31.90
A80884-1008	Rene Magritte	31.90
A80884-1003	Salvador Dali	31.90
A80884-1002	Vincent Van Gogh	31.90
A80884-1001	DIY Vincent Van Gogh	26.40

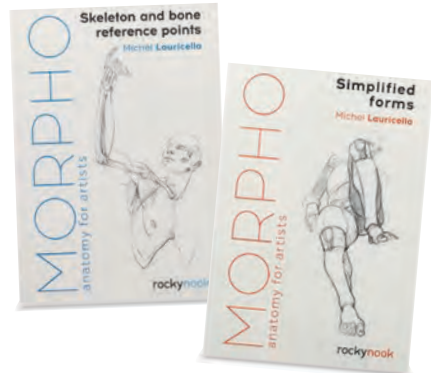

Anatomy for Artists Simplified Forms
These small, portable reference guides focus on the essentials, providing simplified and practical approaches to drawing the human skeleton and body. Michel Lauricella. Paperback. 96 pages. 4-1/2" x 7".

NUMBER	DESCRIPTION	EACH
A69865-1001	Skeleton and Bone Reference Points	\$17.44
A69865-1002	Simplified Forms	17.44



Drawing Lessons from the Famous Artists School
Classic Techniques and Expert Tips from the Golden Age of Illustration
Featuring the work and words of celebrated 20th century illustrators, this trove of inspiration and information includes a series of lessons in classic drawing techniques. Each chapter offers both process and finished works by the founding artists and other instructors of the Famous Artists School. Stephanie Haboush Plunkett and Magdalen Livesey. Paperback. 160 pages. 8-1/2" x 10".

NUMBER	DESCRIPTION	EACH
A71272-1001	Drawing Lessons From Art School	\$26.49



Walter Foster® How to Draw Series
These books offer an introduction to basic techniques with step-by-step instructions. Each book also explains and illustrates various drawing mediums and their uses. Paperback. 10-1/4" x 13-1/4".

NUMBER	DESCRIPTION	EACH
A70107-1137	The Figure	\$8.95



Human Hand Stands
The beautiful flowing form of the human hand stands in dynamic counterpoint to the crisp, geometric lines of the cone, sphere, or other geometric forms it grasps. These delightful two-in-one creations provide a unique and interesting model for drawing, painting, or sculpting. Custom wooden base is removable for multi-angled viewing. Life cast in hard plaster from a large male hand.

NUMBER	DESCRIPTION	EACH	12/EA
A21616-1125	With Cone	\$43.67	\$39.30
A21616-1122	With Cube	43.67	39.30
A21616-1120	With Cylinder	43.67	39.30
A21616-1126	With Empty Fist	43.67	39.30
A21616-1123	With Isocahedron (20 sides)	43.67	39.30
A21616-1121	With Sphere	43.67	39.30
A21616-1124	With Tetrahedron (4 sides)	43.67	39.30



Human Figure Templates
Jointed adult male templates for realistic movement and easy positioning. Very portable and small enough to slip in a drawer. Each has a top hole for hanging.

NUMBER	DESCRIPTION	EACH	6/EA
A21624-1010	Small, 6-3/4"H x 3/4"W	\$15.35	\$13.36
A21624-1020	Lrg, 13-1/2"H x 1-1/2"W	16.04	13.96



Large Face Parts
Matte white face parts are approximately three times life size, large enough to be viewed from the back of the classroom! The smooth, sealed surface resists fingerprints and scratches. Cast of white hydrocol, more durable than plaster models. Face parts can hang flush or sit on a table. **Face parts can be assorted for quantity pricing.**

NUMBER	DESCRIPTION	EACH	12/EA
A21609-1121	Eye	\$35.22	\$31.70
A21609-1122	Nose	35.22	31.70
A21609-1123	Mouth	35.22	31.70
A21609-1124	Ear	35.22	31.70



Human Hands
Look closely and discover the fine details of these life-like models — each crease and fold is there, and the Caucasian flesh tone is very realistic. These hands are soft, rubber-like castings of actual human specimens, encasing sturdy wires that allow you to bend the fingers.

NUMBER	DESCRIPTION	EACH	12/EA
A21613-1001	Sm Male Rt Relaxed	\$60.05	\$54.04
A21613-1000	Lrg Male Rt Spread	60.05	54.04



Dog Manikin
The articulated body and simple shape of this wood dog manikin make it a studio essential for figure sketching. It's also ideal as a whimsical decoration for studios, classrooms, or offices. It measures 6-1/2" high.

NUMBER	DESCRIPTION	EACH	3/EA
A21622-1020		\$23.99	\$21.59



A Life Size Skeleton
Blick's most popular skeleton is made of durable plastic with articulated moving joints and removable arms and legs. Includes nerve branches, vertebral artery, and herniated lumbar disk. Movable skull jaw has three removable teeth. Includes rolling stand and skeletal system chart. 5-1/2 ft tall.

NUMBER	DESCRIPTION	EACH
A21620-1001		\$359.00

B Mr. Thrifty Skeleton
Quality at a bare-bones price! User-friendly, Mr. Thrifty encourages adults and kids to learn bone names and shapes. Upper skull is removable. Not cast to scale. Includes chart of bones and heavy stand. 33-1/2" tall.

NUMBER	DESCRIPTION	EACH
A21620-1002		\$78.61

C My First Skeleton
Washable, unbreakable plastic for hands-on learning fun. Movable spring jaw; skull opens. Removable arms and legs. Includes stand, chart, and a detailed key card. 16-1/2" tall.

NUMBER	DESCRIPTION	EACH
A21620-1003		\$31.66



Budget Skull With Three Removable Teeth
Give students a "head" start! Our lifelike plastic skull dissects into three parts and has three removable teeth (incisor, cuspid, and molar). Movable jaw, cut calvarium, and suture lines. Key card identifies 75 features. 5"W x 8-1/2"H x 6"D.

NUMBER	DESCRIPTION	EACH
A21620-1004		\$39.30



A

A Helix® Lightweight Plain Edge Drawing Board

80% lighter than most wooden boards. Smooth, natural basswood surface on both sides. Resin-impregnated pulp fiber "Airtite" honeycomb core is permanently bonded to basswood surfaces for rigidity and strength. Feather-light feel.

NUMBER	SIZE	EACH	5/EA
A22992-0008	16" x 21"	\$26.73	\$24.06
A22992-0009	18" x 24"	29.50	26.55
A22992-0001	20" x 26"	35.49	31.94
A22992-0002	23" x 31"	44.71	40.24
A22992-0015	24" x 36"	52.55	42.30



B

B Blick® Sketch Board

Perfect for those who need a sketching surface that's firm, sturdy, and portable. Two heavy clips on the large board (only one on the small) hold sketch pad firmly in place, while the oversized rubber band secures it during transport. The board is 1/8" thick Masonite® and very lightweight, with a hand hole for easy carrying.

NUMBER	SIZE	EACH	12/EA
A22945-1007	15" x 16"	\$10.27	\$9.24
A22945-1002	23-1/2" x 26"	17.12	15.41

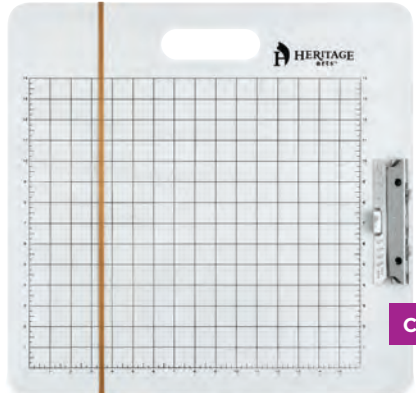

C

C Alvin® Heritage Gridded Sketch Board

Ideal for sketching, layout, and design work. Made of extra-rigid, 4 mm white Masonite® marked with black 1" grid lines and 1/4" hash marks. Includes cutout handle, a firm spring clip for holding sketches in place, and a heavy-duty rubber band for securing your work during transport. The 23-1/2" x 26" board also has two clips for securing your artwork.

NUMBER	SIZE	EACH	6/EA
A49000-1015	15-1/2" x 16-1/2"	\$18.07	\$16.26
A49000-1018	18-1/2" x 19-1/2"	21.37	19.23
A49000-1023	23-1/2" x 26"	30.61	27.55



D

D Helix® Metal Edge Drawing Board

Solid-core construction with a smoothly sanded hardwood laminate surface. The sides have metal edges for use with a T-square and to prevent warping. Upper and lower edges have polyvinyl edging.

NUMBER	SIZE	EACH	5/EA
A22873-1016	16" x 21"	\$41.15	\$37.03
A22873-1018	18" x 24"	46.30	41.67
A22873-1020	20" x 26"	54.88	49.39
A22873-1023	23" x 31"	67.46	60.71
A22873-1024	24" x 36"	78.32	70.49



E

E Richeson® Drawing Clip Board

This heavy-duty drawing board is just what every student needs. Designed for use in the studio or field, it can be carried easily using the cut-out handle. Sturdy spring-loaded clips and a heavy-duty rubber band help keep artwork secure while working or transporting.

NUMBER	EACH	6/EA
A22718-1023	\$19.22	\$17.32

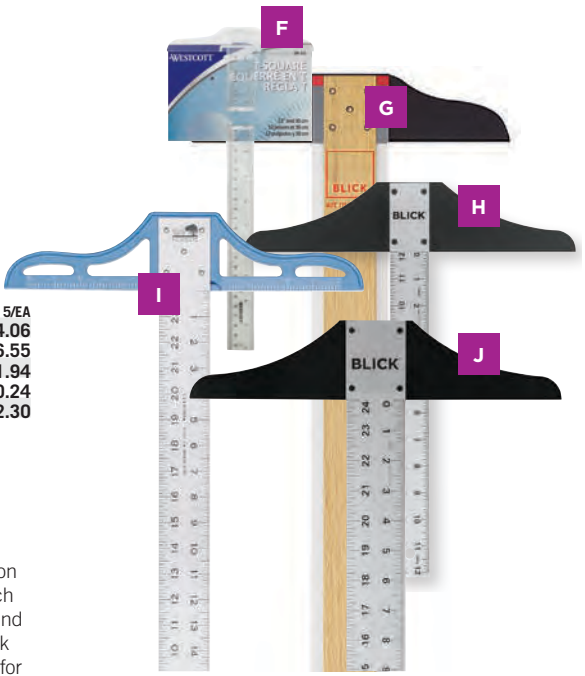

F

F Westcott® Junior T-Square

Helps young students to draw more accurately. Calibrated in inches on one side, metric on the other. 1" wide clear acrylic plastic. 12" long.

NUMBER	EACH	12/EA
A55451-1012	\$3.35	\$2.99

G Blick® Acrylic Edge T-Square

Made of select hardwood with fixed black head. Transparent plastic edges offset for inking. No measurement markings.

NUMBER	SIZE	EACH	6/EA
A55453-1018	18"	\$9.88	\$8.63
A55453-1024	24"	12.50	10.92
A55453-1030	30"	14.34	12.52
A55453-1036	36"	16.87	14.74
A55453-1042	42"	19.94	17.42
A55453-1048	48"	21.86	19.10

H Blick® Standard Aluminum T-Square

A 1-1/2" extruded aluminum blade is calibrated in inches (1/8" and 1/16") on both edges on the front side. The ABS plastic head is lightweight and nearly unbreakable.

NUMBER	SIZE	EACH	6/EA
A56000-1012	12"	\$10.89	\$9.80
A56000-1018	18"	13.99	12.60
A56000-1024	24"	15.15	13.63
A56000-1030	30"	18.58	16.71
A56000-1036	36"	20.14	18.11
A56000-1048	48"	21.69	19.52

I Fairgate™ Heavy-Duty Aluminum T-Square

Plastic head with a high-tempered alloy blade. Calibrated in 1/8" on one edge and 1/16" on the other. 2" wide, 0.081" gauge.

NUMBER	SIZE	EACH	12/EA
A55449-1024	24"	\$31.88	\$28.69
A55449-1036	36"	40.43	36.38

J Blick® Heavy-Duty T-Square

Ideal for drafting boards and cutting projects. The 2" wide, heavy-gauge aluminum blade has a 14" shatter-resistant ABS plastic head. Permanent calibrations are in inches (1/8" and 1/16") on both edges, one side.

NUMBER	SIZE	EACH	6/EA
A56003-1018	18"	\$20.22	\$18.21
A56003-1024	24"	24.39	21.97
A56003-1030	30"	28.04	25.27
A56003-1036	36"	32.11	28.93
A56003-1048	48"	43.49	39.19



Martin™ Universal Design PEB Portable Drawing Board

Ideal for field work! Featuring lightweight parallel edge that adjusts for working at various angles. A smooth, melamine-composite surface is excellent for drawing. The parallel rule eliminates the need for a straight edge or T-square. Includes a convenient carrying handle.

NUMBER	SIZE	EACH
A55652-1009	18" x 24"	\$124.98
A55652-1001	20" x 26"	129.85
A55652-1002	23" x 31"	206.79
A55652-1016	31" x 42"	211.79

Martin™ Pro-Draft Deluxe Parallel Straightedge Drawing Board

The best just got better! This lightweight board with a smooth, melamine-composite drawing surface and five-position tilting mechanism eases back strain. The anti-warp aluminum parallel rule eliminates the need for a straight edge or T-square. Larger knobs make alignment or angle changes easier. Carrying handle included. Ships directly from the manufacturer.

NUMBER	SIZE	EACH
A67918-1020	20" x 26"	\$194.99
A67918-1023	23" x 31"	238.05
A67918-1015	24" x 36"	260.84



K Alvin® Paral-Liner™ Straightedge

Nylon rollers mounted on the blade result in frictionless operation. The rollers retract at a touch, securing the blade for accurate drawing. Elevated Plexiglas® edges eliminate inking smears. Full-length finger lifts offer easy handling while side tension guides eliminate side travel. Rigid phenolic construction with a black satin finish. Includes mounting hardware and instructions. FOB Factory. See page 648 for details.

NUMBER	SIZE	EACH	6/EA
AF55499-1030	30"	\$189.79	\$161.33
AF55499-1036	36"	202.81	172.39
AF55499-1042	42"	217.93	185.25
AF55499-1048	48"	230.99	196.35
AF55499-1060	60"	258.12	219.39

L Alvin® Parallel Rule Cable

Nylon-covered, stainless steel stranded wire for parallel rules. Highly flexible; kink-resistant. 100 ft.

NUMBER	EACH	3/EA
A55478-0100	\$45.63	\$41.07

M Martin Universal™ Parallel Straightedges

High-quality, professional straightedges feature a metal cover for strength and stability and an anti-warp cast acrylic bottom with inking edge. A locking device locks in the desired angle. Anti-static rollers help avoid smudging drawings.

NUMBER	SIZE	EACH	6/EA
A55755-1036	36"	\$134.39	\$120.96
A55755-1042	42"	154.19	138.77
A55755-1048	48"	168.55	151.70

For drawing and drafting tables, see pages 581-583.

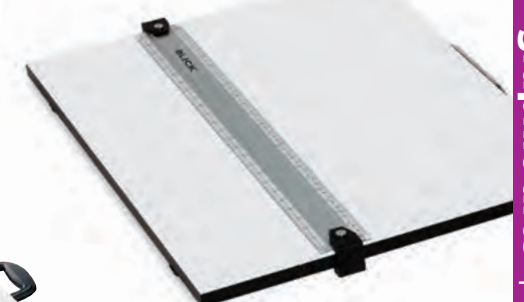

Blick® Portable Drafting Board

The convenience of a studio work surface in a compact, portable unit. Made from 0.55" thick melamine-laminated board, this tabletop board has a clear ruler with an aluminum center, horizontal parallel ruler locks, and engraved ruler markings. No-slip tractor feet grip the table edge at the perfect angle. Chrome carrying handle; foldaway legs. Ships fully assembled. Made in Italy.

NUMBER	SIZE	EACH	6/EA
A55968-1009	18" x 24"	\$135.79	\$122.20
A55968-2009	20" x 26"	145.50	130.95
A55968-3009	23" x 31"	164.89	148.40
A55968-4009	24" x 36"	159.99	143.99
A55968-5009	31" x 42"	198.85	178.99



Koh-I-Noor® Portable Drawing Board

Constructed almost entirely of feather-light plastic that is durable enough to withstand compass points. Features include: paper clamp on lower right, paper clamp/scale on left, automatic locking straightedge with push-button release, guide rails on all four edges for holding straightedge in either direction, and a vinyl carry case with handle. Use with or without the optional Drawing Head (sold separately below). 14-3/4" x 19-1/2".

NUMBER	EACH	6/EA
A55477-1008	\$142.48	\$128.23

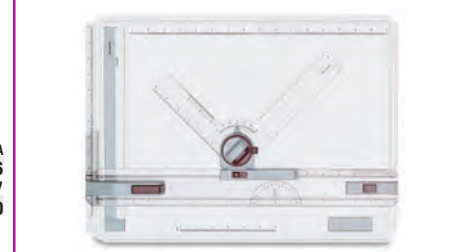

Koh-I-Noor® Drawing Head

Graduated protractor head locks at any desired angle with automatic setting in 15° increments. Fits over and glides across the straightedge quickly and easily except when the rake mechanism is used for repetitive crosshatching and parallel lines. Almost all plastic parts. Transparent, smoke-colored scale. Board sold separately above. 14-3/4" x 19-1/2".

NUMBER	EACH	6/EA
A55477-1015	\$64.10	\$57.69



A



B

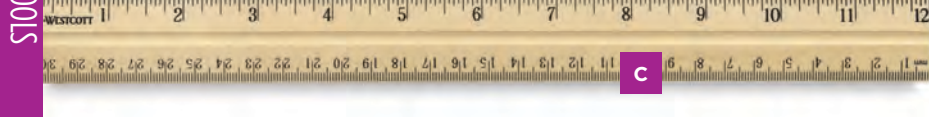

C



D

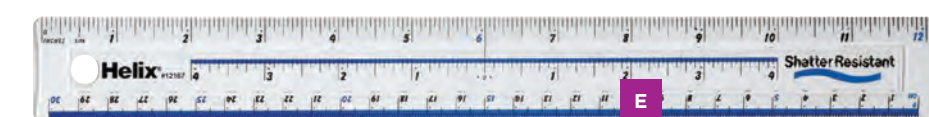

E



F



G



H

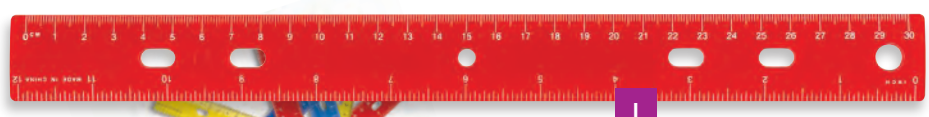

I

A Westcott® Wooden School Ruler

Smoothly finished with a single metal edge and pencil-grooved face. Scaled in 16ths on one side, metric on the other. 1-1/8" wide x 5/32" thick.

NUMBER	SIZE	EACH	24/EA	36/EA
A55427-1012	12"	\$1.14	\$1.04	\$0.99

B Hole-Punched — Designed for easy storage in a three-ring binder.

NUMBER	SIZE	EACH	24/EA	36/EA
A55427-1112	12"	\$1.19	\$1.08	\$1.03

C Westcott® Wooden Ruler

Beveled, treated, and varnished. Brass edge. Scaled in 16ths. 1-5/16" wide x 1/4" thick. Plain back.

NUMBER	SIZE	EACH	24/EA	36/EA
A55425-1012	12"	\$2.09	\$1.88	\$1.79
A55425-1015	15"	2.87	2.59	2.45
A55425-1018	18"	3.03	2.73	2.59

D Blick® Plastic Ruler

This blue plastic ruler is perfect for home, school, or the office. Marked in 16ths. Plain back.

NUMBER	SIZE	EACH	12/EA	48/EA
A55403-1012	12"	\$1.17	\$1.03	\$0.98

E Helix® Shatterproof Plastic Ruler

Clear, unbreakable plastic. 16ths on one edge, centimeters and millimeters on the other.

NUMBER	SIZE	EACH	12/EA	24/EA
A55463-1012	12"	\$2.39	\$2.15	\$2.04

F Westcott® Flexible Inch/Metric Ruler

This transparent ruler features 16ths on one edge, millimeters on the other. Laminated to ensure durability. Great in the classroom, at work, or at home.

NUMBER	SIZE	EACH	12/EA	24/EA
A55693-1006	6"	\$0.74	\$0.67	\$0.64
A55693-1012	12"	1.10	.98	.93

G Westcott® Shatter Resistant Ruler

Ideal for everyday use, this ruler is made of shatterproof, molded plastic. Graduated in inches on one edge and millimeters on the other edge.

NUMBER	SIZE	EACH	12/EA	24/EA
A55700-1012	12"	\$3.13	\$2.81	\$2.67

H Westcott® Finger Grip Ruler

Durable plastic ruler with a raised center grip for easy handling. Scaled in 16ths on one edge, millimeters on the other.

NUMBER	SIZE	EACH	12/EA	24/EA
A55989-1012	12"	\$1.73	\$1.55	\$1.47

I Westcott® Bargain Elementary Plastic Ruler Pack

A pack of 12 strong plastic rulers. 16ths on one edge, centimeters on the other. Plain back.

NUMBER	SIZE	EACH	12/EA	48/EA
A55424-1012	12"	\$10.06	\$9.04	\$8.59

J Blick® Aluminum Ruler

Blick's most popular ruler is used in schools, studios, and sign shops everywhere! This 1-1/8" wide, straight, flat ruler has large, distinct numbers in 8ths and 16ths. Plain back.

NUMBER	SIZE	EACH	12/EA	24/EA
A55430-1012	12"	\$2.32	\$2.08	\$1.98
A55430-1018	18"	2.51	2.26	2.15
A55430-1024	24"	2.83	2.55	2.42
A55430-1036	36"	3.71	3.33	3.17

K Blick® Aluminum Straightedge Rulers

Made of quality extruded aluminum, this ruler features permanent calibrations on both edges in 1/16" and 1/8" increments.

NUMBER	SIZE	EACH	5/EA	10/EA
A56016-1012	12"	\$4.99	\$4.48	\$4.26
A56016-1018	18"	5.81	5.23	4.97
A56016-1024	24"	7.51	6.76	6.42
A56016-1036	36"	13.32	11.99	11.39

L Blick® Aluminum Non-Slip Ruler

Durable neoprene backing prevents slipping better than traditional cork-backed rulers. Permanent photo-anodized calibrations in 8ths and 16ths.

NUMBER	SIZE	EACH	6/EA	12/EA
A56014-1006	6"	\$5.11	\$4.34	\$4.13
A56014-1012	12"	6.73	5.72	5.43
A56014-1018	18"	8.08	6.86	6.52
A56014-1024	24"	8.91	7.56	7.19
A56014-1036	36"	14.30	12.14	11.54
A56014-1048	48"	19.80	16.81	15.98

M Alumaticolor® Standard Straight Edge

Sturdy, tempered aluminum ruler with ultra-smooth edges. Calibrations are photo-anodized in both inches and centimeters, with center finding calibrations on the back.

NUMBER	SIZE	EACH	6/EA	12/EA
A55681-2406	6"	\$4.35	\$3.91	\$3.72
A55681-2412	12"	5.71	5.14	4.88
A55681-2418	18"	6.98	6.29	5.97
A55681-2424	24"	8.13	7.32	6.94
A55681-2430	30"	10.32	9.29	8.82
A55681-2436	36"	11.38	10.24	9.72
A55681-2448	48"	16.03	14.43	13.70

N Blick® Stainless Steel Ruler

Made from high-quality stainless steel with permanently etched calibrations (in 32nds and millimeters) that won't rub off over time. Raised edges prevent ink smears when drawing lines. Cork backing keeps it from slipping on smooth or glass surfaces. Flexible.

NUMBER	SIZE	EACH	5/EA	10/EA
A56009-1012	12"	\$6.21	\$5.59	\$5.31
A56009-1018	18"	8.43	7.59	7.21
A56009-1024	24"	10.21	9.18	8.73

O Alvin® Non-Skid Stainless Steel Ruler

Made of the finest-quality stainless steel with non-skid backing that won't slip on glass or polished surfaces. Graduated to 32nds and 16ths on one side, metric on the other.

NUMBER	SIZE	EACH	12/EA	24/EA
A55632-1012	12"	\$7.34	\$6.61	\$6.27
A55632-1018	18"	11.31	10.19	9.67
A55632-1024	24"	14.99	13.52	12.83
A55632-1036	36"	24.17	21.79	20.68

P Westcott® Metal Zero Centering Ruler

Zero-centering allows for effortless alignment of photos, die-cuts, and more. Find the center point quickly and accurately by aligning the zero so that the same measurement appears on both sides. Cork backing. Scaled in 16ths.

NUMBER	SIZE	EACH	10/EA	20/EA
A55793-1012	12"	\$5.03	\$4.52	\$4.30
A55793-1018	18"	5.87	5.27	4.99
A55793-1024	24"	8.84	7.95	7.56
A55793-1036	36"	14.72	13.23	12.59

Q Westcott® Flexible Stainless Steel Ruler

Non-slip cork backing for precision measuring. First inch is marked in 32nds, the rest in 16ths. Centimeters and millimeters on the other edge.

NUMBER	SIZE	EACH	12/EA
A55489-1006	6"	\$3.47	\$3.12
A55489-1012	12"	5.88	5.29
A55489-1015	15"	6.87	6.17
A55489-1018	18"	8.21	7.38
A55489-1024	24"	10.29	9.25
A55489-1036	36"	17.22	15.48



J



K



L

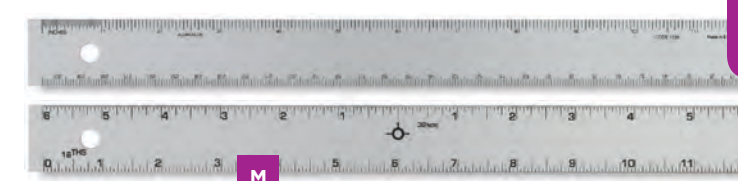

M



N



O



P



Q

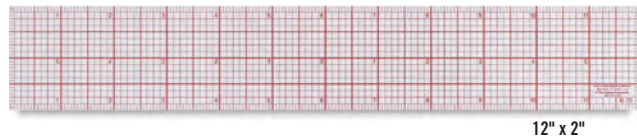

Westcott® Plastic Graph Rulers

Constructed in transparent plastic with beveled edges — good when working with ink. Each ruler has a zero centering scale and is laminated for durability.

8ths Graph Beveled Ruler

NUMBER	LENGTH X WIDTH	EACH	12/EA	24/EA
A55618-0050	6" x 1"	\$2.10	\$1.88	\$1.79
A55618-0060	12" x 1"	2.51	2.26	2.14
A55618-1012	12" x 2"	3.52	3.17	2.99
A55618-1118	18" x 2"	4.95	4.45	4.22

8ths Graph Beveled Ruler, Matted — Stainless steel edge.

NUMBER	LENGTH X WIDTH	EACH	12/EA	24/EA
A55618-1018	18" x 2"	\$7.43	\$6.68	\$6.34

10ths Metric Beveled Ruler

NUMBER	LENGTH X WIDTH	EACH	12/EA	24/EA
A55618-1006	6" x 1"	\$2.10	\$1.88	\$1.79
A55618-0065	12" x 1"	2.51	2.26	2.14

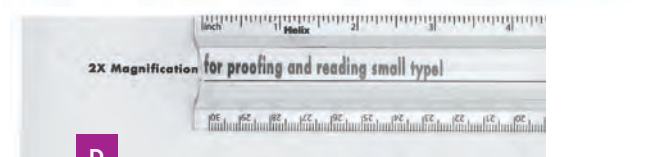
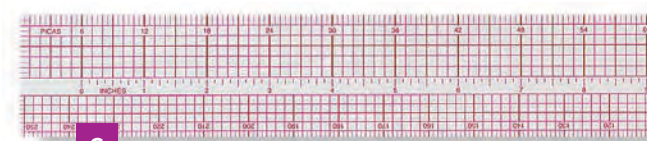
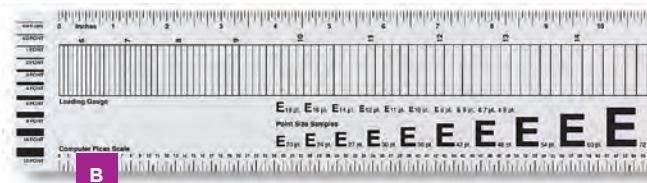
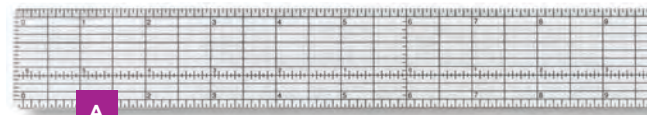

A Westcott® Grid Ruler

Heavy-duty clear plastic grid ruler has one beveled edge and one stainless steel edge for easy and safe cutting. Calibrations and grids are visible on both light and dark surfaces. Graduated in 16ths to the inch. Zero centering scale.

NUMBER	SIZE	EACH	12/EA	24/EA
A55694-1012	12"	\$7.52	\$6.77	\$6.43
A55694-1018	18"	12.51	11.27	10.70

B Westcott® Flexible Typesetter's Ruler

Clear plastic ruler has leading, type size, point rule, pica, point, and inch scales. 13-3/4" x 3".

NUMBER	EACH	12/EA	24/EA
A55421-1003	\$5.54	\$4.97	\$4.74

C Westcott® Transparent Pica Ruler

Transparent rule has beveled edges marked with picas and agate graduations. 18" x 2".

NUMBER	EACH	12/EA	24/EA
A55412-0000	\$4.88	\$4.39	\$4.17

D Helix® Magnifying Ruler

Standard-length 12" clear plastic ruler offers 2X magnification of fine print on copies, prints, and more, with a center line that aids tracking of spreadsheet data.

NUMBER	EACH	12/EA	24/EA
A55762-1012	\$4.82	\$4.35	\$4.12



E AlumiCutter™ Ruler

Measure and cut without changing tools! Made from sturdy, lightweight extruded aluminum. Features a raised edge that's ideal for inking, plus a groove that protects your fingers while cutting. Recessed, non-slip neoprene backing. Marked in 16ths on both edges; first two inches are measured in 32nds. Silver.

Silver

NUMBER	SIZE	EACH	6/EA	12/EA
A55674-2412	12"	\$12.33	\$11.10	\$10.54
A55674-2418	18"	14.23	12.81	12.17
A55674-2424	24"	16.13	14.52	13.80
A55674-2430	30"	18.56	16.71	15.87
A55674-2436	36"	20.89	18.81	17.87

F AlumiCutter™ Steel Edge Ruler

Special heavy-duty, ultra-hard "Steel Edge" version. Features one raised cutting edge, one beveled inking edge, a non-slip back, and a finger groove for safety. Steel edge can be used safely with a rotary blade. Marked in 16ths on both edges; first two inches are measured in 32nds. Black.

Black

NUMBER	SIZE	EACH	6/EA	12/EA
A55644-2012	12"	\$17.88	\$16.09	\$15.29
A55644-2018	18"	20.99	18.91	17.96
A55644-2024	24"	23.79	21.41	20.34
A55644-2036	36"	29.88	26.89	25.55

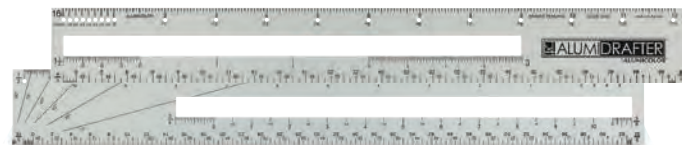

Alumicolor® Alumidrafter™ Drafting and Measuring Tool

An all-in-one drafting and measuring tool. Use it to measure and scale drawings, to draft circles and arcs, and to draw angles and triangles. The two-sided tool has 16 calibrations, featuring all the standard measurements an architect or other user could need. Small holes hold your pencil in place as you create circles and arcs.

NUMBER	EACH	12/EA	24/EA
A63984-9302	\$11.41	\$10.27	\$9.75



Westcott® Rolling Ruler

It's easy to draw horizontal or vertical parallel lines with the Rolling Ruler. Great for drawing lines, angles, and cross-hatching, this multi-purpose 12" plastic ruler rolls easily across surfaces. It also rolls in an arc to draw circles up to 24" in diameter.

NUMBER	EACH	6/EA	12/EA
A55773-1012	\$9.99	\$8.99	\$8.55



Helix® Circle Ruler

This 2-in-1 ruler and compass lets you draw circles from 1"-12". Place the center disk hole on your starting point, then choose the desired circle size (in 1/8" increments), insert pen into hole, then hold down center disk and sweep around with pen in hole until the circle is complete. Features easy pickup handle. Use included circle stencils to draw circles smaller than 1" in diameter (1/16"-9/16"Dia). Color may vary.

NUMBER	EACH	5/EA	10/EA
A55740-1012	\$4.56	\$3.99	\$3.82

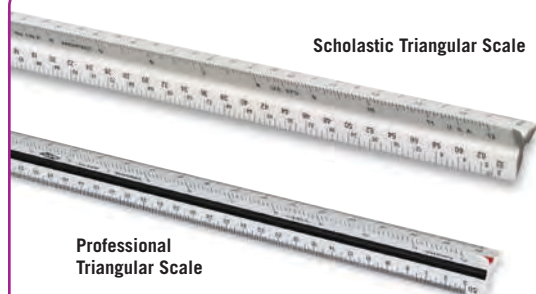

Professional Triangular Scale

Alvin® Scholastic Triangular Scales

Ideal for scholastic and vocational use. Satin finish, high-impact plastic with tapered edges. Sharp, easy-to-read graduations resist wear. White.

NUMBER	EACH	12/EA	24/EA
A55409-1001	\$7.46	\$6.72	\$6.38

Engineering

NUMBER	EACH	12/EA	24/EA
A55409-0000	\$7.46	\$6.72	\$6.38



Alvin® Drafting Dots

A great alternative to drafting tape. They're easy to apply with no waste or corners to snag. The 7/8" diameter dots are individually dispensed from a convenient pull-tab dispenser box. 500 dots per box.

NUMBER	EACH	6/EA
A55470-0000	\$14.48	\$13.03

G Blick® Aluminum L-Squares

A great tool for fashion or graphic designers. Calibrated in inches (8ths and 16ths) on the front and back for both left- and right-handed use. Smooth satin edges allow for "tick-free" drawing lines.

NUMBER	SIZE	EACH	5/EA	10/EA
A56013-1206	12"L x 6"W	\$19.86	\$17.87	\$16.97
A56013-2414	24"L x 14"W	31.45	28.30	26.87

H Westcott® Aluminum Yard/Meter Stick

Hard, instrument-grade aluminum is graduated in 8ths to the inch on one side, millimeters on the other edge. The reverse side provides metric conversion tables for length, area, mass, and volume.

NUMBER	EACH	12/EA	24/EA
A55706-1139	\$9.68	\$8.71	\$8.27

I Westcott® Wood Yardstick

Economical wood yardstick includes a convenient hole for hanging. 36" long and calibrated in 1/8" increments. 1-1/8" wide.

NUMBER	EACH	12/EA	24/EA
A55706-1036	\$4.55	\$4.08	\$3.89

J Excel® Yardstick Compass

Use this pin post/lead point combo to create accurate measurement points and easily make large circles and arcs. Attach pin post and drawing point to standard ruler or yardstick using the screw top, slide to desired position, then tighten the screws.

NUMBER	EACH	12/EA	24/EA
A63996-1001	\$15.18	\$13.66	\$12.98

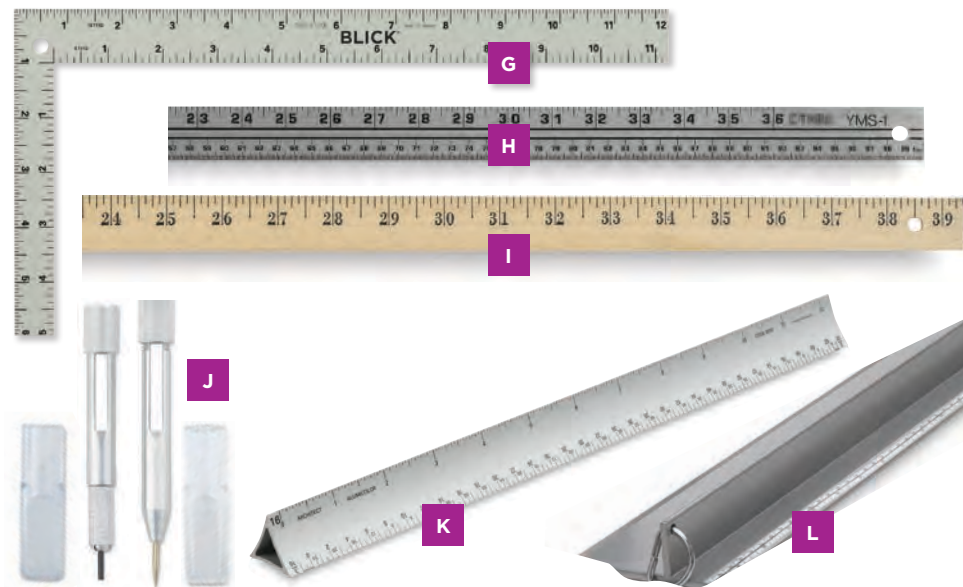

K AlumiCutter™ Triangular Drafting Scales

Made of extruded aluminum, these scales are treated with a photo anodizing process that assures a smooth, tick-free finish and permanent markings that are resistant to cleaners and solvents. The Hollow style is light-weight.

NUMBER	DESCRIPTION	SIZE	EACH	12/EA
A55677-2412	Hollow Architect	12"	\$11.55	\$10.40
A55677-2432	Hollow Engineer	12"	11.55	10.40

Architectural Scale — 12" scale with standard architectural graduations of 3/32, 3/16, 1/8, 1/4, 1/2, 1, 3/8, 3/4, 1-1/2, 3" to the foot; one edge to 16ths.

Engineering Scale — 12" scale with standard engineering graduations of 10, 20, 30, 40, 50, and 60 parts per inch.

Alvin® Professional Triangular Scales

Professional-quality scales made from high-impact plastic with non-reflecting, matte faces and tapered edges. Machine-engraved graduations and color-coded furrows. Includes a hard plastic case.

Architectural

NUMBER	DESCRIPTION	EACH	12/EA	24/EA
A55415-2000	Black	\$13.20	\$11.88	\$11.22
A55415-3000	White	13.20	11.88	11.22
A55415-0000	Yellow	15.50	13.95	13.25

Engineering — Plastic 12" scale divided in 10, 20, 30, 40, 50, and 60 decimal parts to the inch.

NUMBER	DESCRIPTION	EACH	12/EA	24/EA
A55415-0100	White	\$13.20	\$11.88	\$11.22
A55415-2100	Black	13.20	11.88	11.22

new!



NEW! Fiskars® DIY Tape Measure

Perfect for making precise measurements for art, craft, and home décor projects. The Fiskars DIY Tape measures up to 16 ft and locks in place for accuracy. It features yellow, non-glare tape with both English and metric measurements. A metal hook on the end provides stability.

NUMBER	EACH	6/EA
A56215-1016	\$14.29	\$12.85



new!

NEW! STAEDTLER® Super Math Set

The Staedtler Super Math Set contains all the essential tools a student needs for math, architecture, and engineering courses. For complete set contents, visit DickBlick.com.

NUMBER	EACH	6/EA
A56634-1009	\$31.75	\$28.57



Blick® Triangles
Clear acrylic plastic, 0.08" thick, with finger lifts.

30°/60° Triangles

NUMBER	SIZE	EACH	12/EA	24/EA
A55447-1006	6"	\$1.69	\$1.52	\$1.44
A55447-1008	8"	2.46	2.21	2.10
A55447-1010	10"	3.03	2.72	2.58
A55447-1012	12"	3.93	3.54	3.36
A55447-1018	18"	9.37	8.43	7.99

45°/90° Triangles

NUMBER	SIZE	EACH	12/EA	24/EA
A55447-1345	6"	\$1.70	\$1.53	\$1.45
A55447-1445	8"	2.11	1.90	1.81
A55447-1045	10"	3.05	2.74	2.60
A55447-1145	12"	4.13	3.71	3.53
A55447-1245	18"	9.97	8.97	8.52

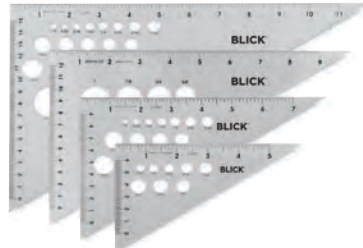

Blick® Aluminum Triangles
Stain-resistant finish and permanent calibrations in both inches and cm/mm. Also includes templates for 7/32" to 1" circles.

30°/60° Triangles

NUMBER	SIZE	EACH	12/EA
A56017-3006	6"	\$6.49	\$5.84
A56017-3008	8"	7.68	6.92
A56017-3010	10"	10.05	9.05
A56017-3012	12"	11.69	10.52

45°/90° Triangles

NUMBER	SIZE	EACH	12/EA
A56017-4506	6"	\$7.10	\$6.39
A56017-4508	8"	10.36	9.32
A56017-4510	10"	13.37	12.03
A56017-4512	12"	18.34	16.50

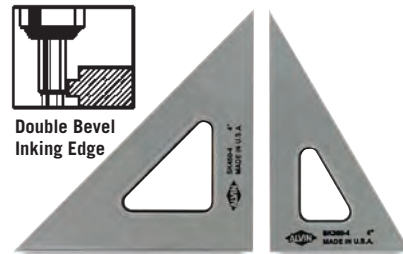

Alvin® Triangles
Smoke-colored styrene plastic with finger lifts. Double-bevel inking edge.

30°/60° Triangles

NUMBER	SIZE	EACH	12/EA	24/EA
A55444-1004	4"	\$2.92	\$2.63	\$2.50
A55444-1006	6"	3.45	3.10	2.95
A55444-1008	8"	4.41	3.96	3.77
A55444-1030	10"	4.62	4.15	3.95
A55444-1012	12"	5.84	5.25	4.99
A55444-1014	14"	8.07	7.25	6.90

45°/90° Triangles

NUMBER	SIZE	EACH	12/EA	24/EA
A55444-1104	4"	\$3.36	\$2.99	\$2.91
A55444-1106	6"	4.59	4.13	3.97
A55444-1108	8"	5.32	4.78	4.60
A55444-1045	10"	6.27	5.64	5.42
A55444-1112	12"	9.24	8.31	7.99



STAEOTLER® Math Set
All the essential tools for math class in a handy storage box. The set is built around Staedtler's Norris Club 550 School Compass, a precision compass with integrated universal adapter and safety point, ideal for students' first circle-drawing exercises. For full set contents, visit DickBlick.com.

NUMBER	EACH	6/EA	12/EA
A63979-1109	\$13.86	\$12.47	\$11.85

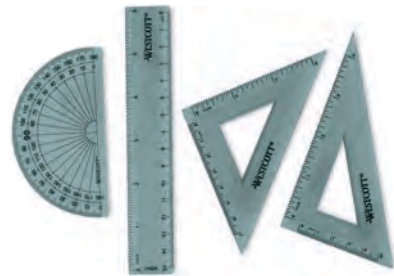

Westcott® Combo Sets
The tools in these sets are molded of clear plastic with legible black markings. Each set contains an inch and metric ruler, 180° protractor, and 45° and 60° triangles in a plastic pouch.

NUMBER	SIZE	EACH	6/EA	12/EA
A55467-1006	6"	\$4.05	\$3.64	\$3.47
A55467-1008	8"	5.77	5.19	4.94
A55467-1012	12"	7.44	6.69	6.30



Helix® Angle & Circle Maker
A 360° protractor, compass, and circle template that allows measuring of angles just like a standard protractor. Center disk has eight circle templates and rotates for drawing different sized circles. 6" diameter. Assorted colors (we choose).

NUMBER	EACH	5/EA	10/EA
A55990-1001	\$4.53	\$4.08	\$3.88



Derwent® Scale Divider
Easily transfer measurements from real life, photographs, and sketches to your canvas or paper, while getting the correct perspectives in drawings. Scale your pictures in ratios from 4:1 to 1:4. Folds neatly away for storage or transport.

NUMBER	EACH	4/EA	8/EA
A22275-9000	\$16.47	\$14.83	\$14.08



Helix® Swing Arm Protractor
The swinging arm of this protractor rotates 180°, making it easy to measure and draw accurate angles. Made of transparent, shatter-resistant plastic in assorted colors (we choose). 6" wide.

NUMBER	EACH	10/EA	20/EA
A56207-1006	\$2.94	\$2.64	\$2.51



Alvin® Semicircular Protractor
Molded of clear plastic with beveled edges. Black markings are in 1" increments. 6" wide.

NUMBER	EACH	12/EA	24/EA
A55646-0006	\$3.31	\$2.98	\$2.80

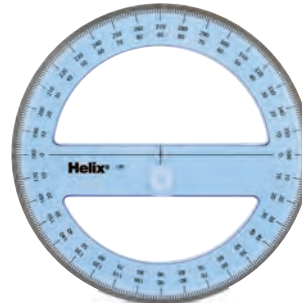

Helix® Full Circle Protractor
Precisely divided into half degrees from 0° to 360°. Transparent 0.1" thick plastic. 6" diameter.

NUMBER	EACH	12/EA	24/EA
A55454-1006	\$3.80	\$3.42	\$3.25



Westcott® Proportional Scale
Calculates enlargements or reductions from 10% to 1000%, 1" to 100". Tough plastic. Easy-to-read markings.

NUMBER	SIZE	EACH	12/EA	24/EA
A55473-1005	5"Dia	\$5.89	\$5.29	\$5.04
A55473-1001	6"Dia	7.76	6.97	6.64
A55473-1083	8-1/4"Dia	9.15	8.21	7.83



A Maped® Study Compass
This compass offers sleek styling, durable metal construction, and a universal holder that accommodates almost any writing instrument. Its ergonomic design is comfortable to grip and easy to use.

NUMBER	EACH	10/EA	20/EA
A56622-1001	\$2.03	\$1.83	\$1.74

B Helix® Safety Compass
The blunt metal tip on this compass is safe for use even by children, yet it works well on all papers. A lockable graduation arm helps create perfect circles up to a 12" diameter. The compass features both inch and metric scales and includes a 3-1/2" pencil. Five colors; we choose.

NUMBER	EACH	6/EA	12/EA
A55737-1007	\$2.70	\$2.43	\$2.30



Westcott® Compass and Protractor Set
Great for the entry-level math student, this set includes a brightly colored, student-grade 6" safety compass and a 6", 180° protractor.

NUMBER	EACH	12/EA	24/EA
A55777-1006	\$3.77	\$3.40	\$3.23



Circle Master Compass
Use with marker, pen, pencil, or X-Acto® knife. Knurled center nut makes precision adjustment easy and holds setting. Draw circles up to 8" in diameter.

NUMBER	EACH	12/EA	36/EA
A55435-0000	\$3.52	\$3.16	\$2.99



C Helix® Bow Compass
A durable all-metal bow compass that's perfect for student use. Features easy-to-adjust center wheel for accurate and easy measuring. Spare leads are included. Measures 7" long overall and draws circles up to 6" in diameter.

NUMBER	EACH	12/EA	24/EA
A56638-1001	\$7.04	\$6.34	\$5.99

D STAEOTLER® 550 Compass with Universal Adapter
A precision compass with a universal adapter that accommodates any writing instrument. Draws circles up to 11-13/16". Ribbed legs for a better grip. Includes storage box with integrated ruler.

NUMBER	EACH	12/EA
A56635-1001	\$5.68	\$5.11



Alecs Dual-Use Touch Screen Drafting Tool Kit
The lead holder and technological compass in this kit can be used on paper or a touch screen simply by changing the tip. It also includes lead and a rubber cap to attach to the lead holder and compass, plus two plastic triangles.

NUMBER	EACH	6/EA
A56214-1001	\$66.58	\$59.93



SAFE-T™ Compass
A great basic compass for children to learn compass skills at an early age — easy, safe, and accurate. Fixed radii make circle/arc and geometric construction work simpler. Draws circles from 1/4" to 10" in diameter in 1/8" increments. 4" straight edge on two sides.

NUMBER	EACH	12/EA	24/EA
A55487-0000	\$1.77	\$1.59	\$1.51

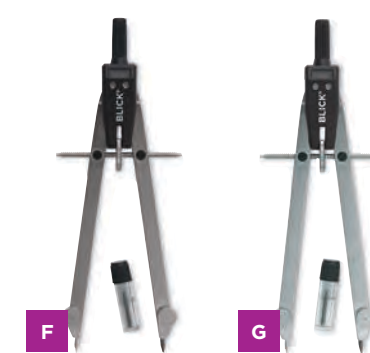

F Blick® Double-Hinged Geometry Compass
Double-hinged legs make this precision geometry compass a great choice for those requiring an accurate, versatile tool. Includes a spring bow head, center wheel adjustment, and removable lead holder leg. Maximum circle 6-1/8".

NUMBER	EACH	6/EA
A56011-1002	\$13.95	\$12.55

F Blick® Large Spring Bow Compass
A precision geometry compass with spring-bow head and center wheel. The legs extend for a maximum circle of approximately 8-7/8". Includes one extra lead. Compass measures 6-1/8" long. Packaged in a plastic case.

NUMBER	EACH	6/EA
A56008-1003	\$14.05	\$12.65

G Blick® Masterbow Compass
Its self-centering head mechanism makes equidistant measuring quick and easy. Durably constructed with a nickel-plated finish. 6" long. Includes two spare needles, two double-ended points, and storage case.

NUMBER	EACH	6/EA
A56004-1001	\$8.66	\$7.79



Blick® Geometry Compass Set
This precision metal compass has a spring-bow head, center wheel, hinged leg joint, and removable needle leg. The set includes an extension bar, universal adapter for writing instruments, and extra lead. Makes a maximum circle of approximately 10-3/8". Compass measures 6-1/8" long. Packaged in a plastic case.

NUMBER	EACH	6/EA
A56011-1001	\$28.29	\$25.46



Alvin® Compass Leads
These H compass leads work in all standard drawing instruments. Pre-sharpened chisel points. Tube holds 12 leads, each 2 mm in diameter x 3/4" long.

NUMBER	EACH	12/EA	24/EA
A55482-1012	\$3.22	\$2.90	\$2.75

CHARTPAK

Chartpak Pickett Templates

Smoke gray with built-in risers and smooth apertures to reduce smudged lines. 0.13" thick. Made in the USA.

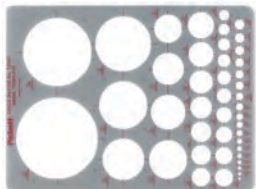

Circle Master — 7" x 9-1/4". Circles ranging from 1/16" to 3" in diameter.
 NUMBER EACH 12/EA 24/EA
 A55476-0100 \$15.96 \$14.36 \$13.65

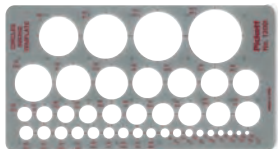

Circles — 4" x 7-1/4". Circles ranging from 1/16" to 1-3/8" in diameter.
 NUMBER EACH 12/EA 24/EA
 A55476-0200 \$13.97 \$12.57 \$11.94

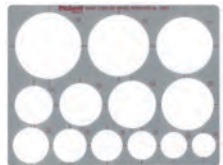

Giant Circles — 8-3/4" x 11-1/2". Circles ranging from 1-1/4" to 3-1/2" in diameter.
 NUMBER EACH 12/EA 24/EA
 A55476-0700 \$15.96 \$14.36 \$13.65



Circle Radius Master — 7-1/2" x 10". Circles ranging from 3/64" to 7-1/2" in diameter.
 NUMBER EACH 12/EA 24/EA
 A55476-9000 \$17.78 \$15.99 \$15.20



Circle Indicator — 6" x 10". Circles ranging from 3/64" to 2" in diameter.
 NUMBER EACH 12/EA 24/EA
 A55476-2001 \$20.62 \$18.55 \$17.63

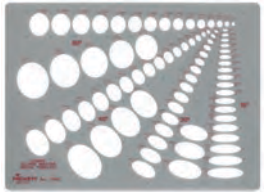

Combination Ellipse Master — 8-3/4" x 12". Size range: 15°-3/16" to 1-5/8", 30°-1/8" to 1-1/2", 45°-1/8" to 1-3/4", 60°-1/8" to 1-5/8".
 NUMBER EACH 12/EA 24/EA
 A55476-0300 \$23.47 \$21.12 \$20.06

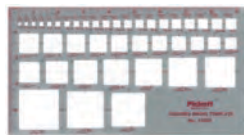

Squares — 5" x 9-1/2". Ranging from 1/16" to 1-1/2".
 NUMBER EACH 12/EA 24/EA
 A55476-1800 \$13.50 \$12.15 \$11.54

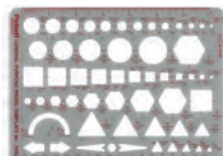

General Purpose — 6" x 8". Circles, squares, hexagons, and triangles.
 NUMBER EACH 12/EA 24/EA
 A55476-0500 \$15.96 \$14.36 \$13.65



Landscape — 8" x 10". Plan views of trees, shrubs, walks, and related configurations. Scale: 1/4" = 1 ft.
 NUMBER EACH 12/EA 24/EA
 A55476-2006 \$23.47 \$21.12 \$20.06



Home Furnishings — 5-1/2" x 9-1/4". Interior design. Scale: 1/4" = 1 ft.
 NUMBER EACH 12/EA 24/EA
 A55476-0800 \$17.63 \$15.86 \$15.07



House Plan Fixtures — 8" x 10". Kitchens and bathrooms. Scale: 1/4" = 1 ft.
 NUMBER EACH 12/EA 24/EA
 A55476-0900 \$17.63 \$15.86 \$15.07



General Purpose Junior — 3" x 3". Circles, squares, hexagons, and triangles. Circles range from 3/32" to 9/16" in diameter.
 NUMBER EACH 12/EA 24/EA
 A55476-0600 \$10.64 \$9.57 \$9.09

WESTCOTT

Westcott Templates

Durable, translucent green, flexible plastic.



Small Circles — 4" x 8". Circles from 1/16" to 1", plus four different corner radii.
 NUMBER EACH 12/EA 24/EA
 A55475-1004 \$5.67 \$5.10 \$4.85



Large Circles — 8" x 10-1/8". Circles from 1" to 2", plus four different corner radii.
 NUMBER EACH 12/EA 24/EA
 A55475-1008 \$7.05 \$6.34 \$6.03

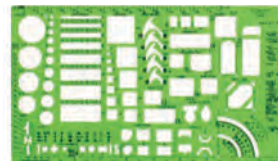

Architectural — 6" x 10". Scale: 1/4" = 1 ft. Incorporates all necessary symbols for architects, engineers, and builders.
 NUMBER EACH 12/EA 24/EA
 A55475-1006 \$8.39 \$7.54 \$7.17

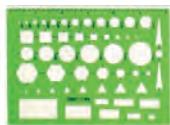

General Purpose — 4-1/2" x 6". Conventional shapes, plus a handy inch scale.
 NUMBER EACH 12/EA 24/EA
 A55475-1045 \$6.47 \$5.82 \$5.53

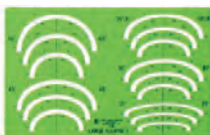

Large Ellipse 1 — 5" x 8". Ellipses from 1-3/4" to 3" in 1/4" increments. 15°, 30°, 35°16', 45°, and 60° projections.
 NUMBER EACH 12/EA 24/EA
 A55475-1102 \$7.61 \$6.84 \$6.51

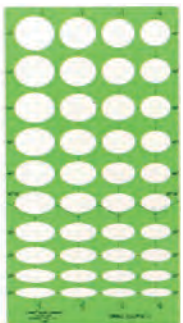

Small Ellipse 3 — 6-3/4" x 12-1/8". Ellipses from 1-1/8" to 1-1/2". 15° to 60° projections in 5° increments.
 NUMBER EACH 12/EA 24/EA
 A55475-1068 \$7.05 \$6.34 \$6.03

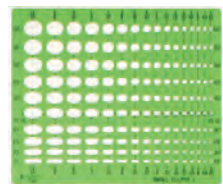

Small Ellipse 1 — 6-3/4" x 8". Ellipses from 3/32" to 11/16". 15° to 60° projections in 5° increments.
 NUMBER EACH 12/EA 24/EA
 A55475-1001 \$8.15 \$7.33 \$6.97

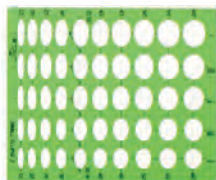

Small Ellipse 2 — 6-3/8" x 8". Ellipses from 3/4" to 1". 15° to 60° projections in 5° increments.
 NUMBER EACH 12/EA 24/EA
 A55475-1002 \$7.05 \$6.34 \$6.03

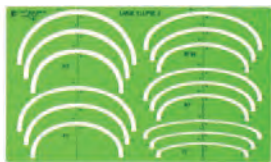

Set of 5 Ellipse Templates — Includes Small Ellipse 1, 2, and 3; Large Ellipse 1 and 2.
 NUMBER EACH 12/EA 24/EA
 A55492-1009 \$23.71 \$21.34 \$20.27

Large Ellipse 2 — 6" x 10-1/8". Ellipses from 3-1/4" to 4-1/2" in 1/4" increments. 15°, 30°, 35°16', 45°, and 60° projections.
 NUMBER EACH 12/EA 24/EA
 A55475-1000 \$7.61 \$6.84 \$6.51

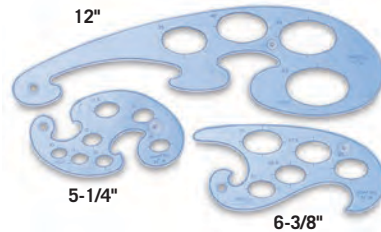

Helix French Curves Set

Set includes one of each style shown above (5-1/4", 6-3/8", 12"). Blue-tinted, transparent plastic. 0.095" thick. Double-inking edges.

NUMBER EACH 6/EA 12/EA
 A55443-1009 \$5.61 \$5.04 \$4.79



Westcott French Curve Sets

Crystal-clear, 0.08" thick plastic with inking edges. Sizes range from 6-3/16" to 10-3/8".

NUMBER SET EACH 6/EA 12/EA
 A55452-1049 Set of 4 \$9.13 \$8.10 \$7.70
 A55452-1009 Set of 8 15.40 13.67 12.99



Alvin French Curve Set

Contains three of the most popular curves, made of tough, 0.08" green-tinted plastic, in a vinyl storage envelope. Includes 5-1/2", 6-1/2", and 12-1/2".

NUMBER EACH 6/EA 12/EA
 A55630-7009 \$11.39 \$10.25 \$9.76



Alvin Tru-Flex II Flexible Curve

The Tru-Flex II features a lightweight aluminum core that is easily shaped into any curve — and then holds it for accurate drawing. Convenient inking edges for pen and marker use; flat edges on both sides for pencil drawing. Lead-free and phthalate-free. Includes inch and metric graduations.

NUMBER SIZE EACH 6/EA 12/EA
 A55744-2012 12" \$12.34 \$11.11 \$10.53
 A55744-2016 16" 12.42 11.18 10.62
 A55744-2024 24" 19.99 18.04 17.14
 A55744-2032 32" 27.23 24.51 23.25
 A55744-2040 40" 34.43 30.99 29.44



Learning Resources Primary Shapes Template Set

Relational shapes help students make mental connections as they compare shapes. That's why this set of five labeled templates is so great. Each of the durable shapes is a bright primary color. Templates support NCTM Early Learning Standards for geometry and shape relations. The rectangle measures 7-1/2"L x 4-1/2"H.

NUMBER EACH 6/EA 12/EA
 A55784-1005 \$8.80 \$7.93 \$7.53



Helix Lettering Guide Value Packs

Convenient pouches hold four sturdy plastic templates, including 1/4", 1/2", 3/4", and 1-1/4" sizes. For template descriptions, visit DickBlick.com.

NUMBER DESCRIPTION EACH 5/EA
 A55466-1004 Assorted \$7.92 \$7.12
 A55767-1004 Italics 7.92 7.12
 A55466-0000 Standard 7.92 7.12



Duro Oil Board Lettering Stencils

Sharp, clean, die-cut letters in Gothic style. Sets include alphabet in caps, numerals, \$, comma, period, hyphen, and &.

NUMBER SIZE EACH 12/EA
 A28929-0005 1/2" \$2.69 \$2.41
 A28929-0010 1" 2.80 2.51
 A28929-1002 2" 3.10 2.78
 A28929-1003 3" 4.35 3.90
 A28929-1004 4" 5.99 5.39
 A28929-1005 5" 7.15 6.41
 A28929-1006 6" 8.49 7.62
 A28929-1008 8" 14.93 13.44
 A28929-1010 10" 24.48 22.03



Westcott LetterCraft Plastic Letter Stencils

Premium-quality, transparent blue plastic makes aligning your letters virtually effortless. Smooth, die-cut edges result in crisply traced lines each and every time. For more fonts, visit DickBlick.com.

Brush
 NUMBER DESCRIPTION SIZE EACH 12/EA
 A55786-1034 Capitals/Lowercase 3/4" & 1" \$6.45 \$5.80
 A55786-1002 Capitals/Lowercase 2" 6.70 5.99
 A55786-1003 Capitals/Lowercase 3" 11.69 10.53
 A55786-1004 Capitals Only 4" 12.31 11.07
 A55786-1006 Capitals Only 6" 16.43 14.78

Helvetica
 NUMBER DESCRIPTION SIZE EACH 12/EA
 A55786-2034 Capitals/Lowercase 3/4" & 1" \$6.45 \$5.80
 A55786-2002 Capitals/Lowercase 2" 6.70 5.99
 A55786-2003 Capitals Only 3" 6.70 5.99
 A55786-2004 Capitals Only 4" 8.99 8.10
 A55786-2006 Capitals Only 6" 17.69 15.94

Helvetica Bold
 NUMBER DESCRIPTION SIZE EACH 12/EA
 A55786-2134 Capital/Lowercase 3/4" & 1" \$6.45 \$5.80
 A55786-2102 Capital/Lowercase 2" 6.70 5.99
 A55786-2103 Capitals Only 3" 7.60 6.85

Marker
 NUMBER DESCRIPTION SIZE EACH 12/EA
 A55786-3034 Capital/Lowercase 3/4" & 1" \$6.45 \$5.80
 A55786-3002 Capital/Lowercase 2" 6.70 5.99

Nueva
 NUMBER DESCRIPTION SIZE EACH 12/EA
 A55786-4034 Capital/Lowercase 3/4" & 1" \$6.45 \$5.80
 A55786-4002 Capital/Lowercase 2" 8.16 7.30
 A55786-4004 Capitals Only 4" 10.99 9.88

Candy
 NUMBER DESCRIPTION SIZE EACH 12/EA
 A55786-3401 Capital/Lowercase 3/4" & 1" \$6.45 \$5.80

Chunky
 NUMBER DESCRIPTION SIZE EACH 12/EA
 A55786-1106 Capitals Only 6" \$16.43 \$14.78



Alvin Ames Lettering Guide

Whether you're writing calligraphy on wedding invitations or lettering comic strips, the Lettering Guide ensures consistency in the size and uniformity of your letters. Made of durable plastic, it has both English and metric line spacing. 3-7/8" x 2-3/8".

NUMBER EACH 6/EA 12/EA
 A56611-1001 \$3.65 \$3.27 \$3.10



GAP™ Econo Self-Piercing Grommet Machine

Quickly and easily add grommets to murals, backdrops, and more without the need to pre-punch a hole. This machine may be economical, but it's built to last. Made of cast iron, its lever mechanism is as simple to use as a stapler. The lever has a rubber grip for comfort. For more sizes, visit DickBlick.com.

NUMBER	DESCRIPTION	EACH
A27414-1002	Machine Only with Size 2 Die	\$258.12
A27414-8102	Grommets Only, Size 2, Pkg of 500	88.54



Banner on a Roll

Banner material is perfect for doing it yourself and is far less expensive than custom ordering. Dispense the exact amount you need. Grommets every 24" make it easy to secure. 11.5 oz vinyl accepts screen printing inks and paint. Hemmed edges offer durability and strength.

NUMBER	DESCRIPTION	EACH	6/EA
A27400-2052	22" x 24 yd	\$142.65	\$128.38
A27400-2053	34" x 24 yd	174.60	157.13
A27400-2054	46" x 24 yd	211.12	189.99

NUMBER	DESCRIPTION	EACH	6/EA
A27400-2982	22" x 24 yd	\$142.65	\$128.38
A27400-2983	34" x 24 yd	174.60	157.13
A27400-2984	46" x 24 yd	211.12	189.99

NUMBER	DESCRIPTION	EACH	6/EA
A27400-1042	22" x 24 yd	\$142.65	\$128.38
A27400-1043	34" x 24 yd	174.60	157.13
A27400-1044	46" x 24 yd	211.12	189.99

NUMBER	DESCRIPTION	EACH	6/EA
A27400-4022	22" x 24 yd	\$142.65	\$128.38
A27400-4023	34" x 24 yd	174.60	157.13
A27400-4024	46" x 24 yd	211.12	189.99



Plastruct Polystyrene Foam

This white expanded polystyrene foam is ideal for creating terrain or topographic models, and unfinished or finished block models. Cut it with a saw, knife, or hot wire cutter.

NUMBER	SIZE	EACH	12/EA
A56930-1201	12" x 24" x 1"	\$11.89	\$10.70
A56930-1236	12" x 36" x 1"	15.85	14.27
A56930-1204	12" x 24" x 4"	35.17	31.65



OOK™ Specialty Wire

Ideal for architectural design projects, 3-D models and sculpture. Packaged on a blister card with a built-in wire cutter. Choose from a variety of gauges and lengths, in dark annealed, copper, or aluminum.

NUMBER	DESCRIPTION	EACH	8/EA
A33418-2819	Aluminum 18 Gauge, 50 ft	\$7.93	\$7.13
A33418-1024	Annealed 24 Gauge, 100 ft	6.99	6.30
A33418-1028	Annealed 28 Gauge, 100 ft	6.99	6.30
A33418-9522	Copper 22 Gauge, 75 ft	9.10	8.19

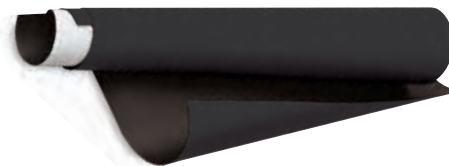

Flexible Magnetic Sheets

Tough and durable. Great for making removable signs on vehicles and other metal surfaces. The smooth, non-porous, weather-resistant material contains no plasticizers, so it won't damage painted surfaces. Hand-letter or screen print your message with lettering enamels or inks. No cleaning or prep required. 0.030" thick.

White — Sold by the foot.

NUMBER	WIDTH	EACH	10/EA
A28921-1012	12"	\$3.62	\$3.26
A28921-1024	24"	7.15	6.43

Colors — 24" wide. Sold by the foot.

NUMBER	COLOR	EACH	10/EA
A28921-2024	Black	\$7.59	\$6.83
A28921-7000	Green	7.59	6.83
A28921-3024	Red	7.59	6.83
A28921-4024	Yellow	7.59	6.83



Corrugated Plastic Panels

An economical alternative to cardboard, these lightweight, strong polypropylene panels are weather-resistant, UV-stable, and durable. They're easy to fold, score, and cut. Great for outside displays. Vinyl letters and most paints adhere well. 4 mm thick. 20" x 30" sheets.

NUMBER	COLOR	EACH	12/EA
A13215-1043	White	\$5.68	\$5.11
A13215-1603	Clear	5.68	5.11



Clear Acrylic Sheets

Acrylic plastic is a non-breakable, lightweight material that can be cut, drilled, buffed, cemented, sanded, beveled, textured, formed, and painted. Its uses are widespread, including furniture, sculpture, product displays, signs, and picture frames. 250°–300°F temperatures are all that are required to bend and form it.

1/8" Thick				
NUMBER	SIZE	EACH	6/EA	
A28945-1004	12" x 12"	\$8.92	\$8.03	
A28945-1006	12" x 24"	18.52	16.67	
A28945-1003	12" x 36"	29.08	26.17	
A28945-1002	24" x 24"	38.38	34.54	
A28945-1015	24" x 36"	58.65	52.79	

1/4" Thick				
NUMBER	SIZE	EACH	6/EA	
A28945-0004	12" x 12"	\$20.29	\$18.26	
A28945-0006	12" x 24"	40.66	36.60	
A28945-0003	12" x 36"	60.96	54.86	
A28945-0002	24" x 24"	82.43	74.19	
A28945-0015	24" x 36"	123.60	111.24	



Non-Glare Acrylic Sheets

Popular for picture framing when a soft, non-reflective surface is desired. One side is non-glare, the other side is glossy. 1/8" thick.

NUMBER	SIZE	EACH	6/EA
A28946-0000	5" x 7"	\$8.17	\$7.36
A28946-0012	8" x 10"	16.15	14.54
A28946-0023	9" x 12"	21.87	19.68
A28946-0005	11" x 14"	34.74	31.28
A28946-0006	12" x 16"	42.72	38.45
A28946-0017	14" x 18"	55.07	49.57
A28946-0008	16" x 20"	70.99	63.90



Flexible Magnetic Strip

Magnetic on one side, adhesive-coated on the other side. Useful for attaching to the back of non-magnetic sign material to make it magnetic. Cuts easily to desired size. 1/16" thick. Sold by the foot.

NUMBER	WIDTH	EACH	10/EA
A28957-0050	1/2"	\$5.54	\$4.48
A28957-1001	1"	.98	.88



Midwest Products' Easy Cutters

Fast, accurate tools for cutting small wood strips. Convenient die-cast aluminum alignment angle plate makes accurate angle cuts. High carbon steel blades; comfort-grip handles. For more details, visit DickBlick.com.

NUMBER	DESCRIPTION	EACH	6/EA
A35106-1000	Easy Cutter	\$32.17	\$28.95
A35106-1004	Super Easy Cutter	27.04	24.33
A35106-1005	Easy Cutter Ultimate	40.25	36.23



Midwest Products' Easy Mitre Box Deluxe

Cut 30°, 45°, 60°, 90°, and 67-1/2° mitre angles in wood and plastic for picture frames, school projects, hobby/craft projects. Accepts materials up to 2" wide and 1/2" thick. Made of injection-molded plastic with three Cam Clamps that hold material being cut firmly in place. Includes Zona Razor Saw with thin blade and 32 teeth per inch for finer cuts.

NUMBER	EACH	6/EA
A35131-1001	\$17.35	\$15.62



Midwest Products' A-Frame Cabin Kit

Everything you need to create a 3/4" scale model of a one-bedroom A-Frame Cabin with a bathroom, kitchen, living room, spiral staircase, and loft. Learn unconventional framing in accordance with accepted building codes. Foot pad measures 1-1/2" x 2 ft. For kit contents, visit DickBlick.com.

NUMBER	EACH
A60460-1004	\$185.18

Art Alternatives™ Modeling Pulp Board

Cream-colored, pH-neutral modeling board is a versatile item for architectural model making and sculpting. Cuts like butter at any angle, allowing for precise detail work, and accepts a variety of media. Sand edges and surface to correct mistakes or add texture. Add coverings or laminate to other boards using adhesives. Bends easily using steam or water; regains rigidity when dry. 30" x 40" x 1/16" thick.

NUMBER	EACH	10/EA
A57347-3040	\$6.76	\$6.07

WARNING! Products marked with a Prop 65 symbol (■ or ▼) can expose you to chemicals, including cadmium, which are known to the State of California to cause cancer and birth defects or other reproductive harm. For more information, visit P65Warnings.ca.gov.



Midwest Products' House Structure Kit

A 3/4" scale two-bedroom home with a bathroom, kitchen, hallway, and dining room. Kit includes micro-cut balsa wood, cutting tools, measuring tape, layout pencils, nails, custom mitre fixture, instruction booklet, nine working drawings, and a work base that doubles as the foundation of the completed model. All the walls can be framed right on the patterns of the working drawings. Grades 6–12.

NUMBER	DESCRIPTION	EACH
A60460-1001	Hip Roof	\$185.18
A60460-1002	Truss Roof	185.18



Midwest Products' 2-Story Townhouse Kit

This 3/4" scale kit combines conventionally framed and balloon-framed walls, trusses, and conventional rafters, floor joists, and sub-floor sheathing. Includes micro-cut balsa wood, working drawings, instructions, cutting tools, nails, glue, layout pencil, measuring tape, custom mitre jig, and a foam base that doubles as a foundation. Grades 6–12.

NUMBER	EACH
A60460-1003	\$185.18



Midwest Products' Bridge Building Kits

Bridge building is an exercise in creative problem-solving. It supports a variety of curricula, including geometry, physics, technology education, math, and general science. Students are challenged to design and construct a bridge of maximum efficiency. Kits contain either 360 pieces of stronger, denser 3/32" x 3/32" x 24" basswood or lighter 1/8" x 1/8" x 24" balsa wood, a teaching booklet, and enough adhesive for 24 bridges. Grades 6–12.

NUMBER	DESCRIPTION	EACH
A60459-1009	Basswood	\$93.95
A60459-2009	Balsa	93.95



Woodland Scenics' Model Scenery

Add authenticity to your layout or diorama with Woodland Scenics trees, foliage, water, figures, and more. Available in a variety of sizes, colors, and formats, these realistic scenery pieces have been designed to meet the specialized needs of architectural modelers, as well as students of architecture, landscaping, and interior design. For more details, visit DickBlick.com.

Trees and Foliage

NUMBER	DESCRIPTION	EACH	12/EA
A61780-1030	Assorted Flowers, 4 Colors	\$5.45	\$4.90
A61780-7013	Bushes, Forest Green	7.17	6.56
A61780-7011	Bushes, Light Green	7.15	6.54
A61780-7012	Bushes, Medium Green	7.15	6.54
A61780-7050	Clump Foliage, Light Green	9.30	8.38
A61780-1010	Conifer Trees	11.99	10.80
A61780-1040	Deciduous Trees 3/4"-2"	17.84	16.07
A61780-1050	Deciduous Trees 2"-3"	17.84	16.07
A61780-7003	Foliage, Dark Green	7.17	6.56
A61780-7001	Foliage, Light Green	7.15	6.54
A61780-7002	Foliage, Medium Green	7.17	6.56
A61780-7135	Ready Made Trees, Dark Green 5"-6"	16.72	15.05

A61780-7136	Ready Made Trees, Dark Green 6"-7"	20.41	18.36
A61780-7122	Ready Made Trees, Medium Green 2"-3"	14.12	12.69
A61780-7123	Ready Made Trees, Medium Green 3"-4"	15.11	13.61
A61780-7124	Ready Made Trees, Medium Green 4"-5"	16.72	15.05

Figures

NUMBER	DESCRIPTION	EACH	12/EA
A61780-2016	Seated Scale People 1/16"	\$17.99	\$16.21
A61780-2008	Seated Scale People 1/8"	17.46	15.72
A61780-2014	Seated Scale People 1/4"	28.82	25.94
A61780-1016	Standing Scale People 1/16"	16.37	14.74
A61780-1008	Standing Scale People 1/8"	17.46	15.72
A61780-1014	Standing Scale People 1/4"	28.82	25.94



Turf and Water

NUMBER	DESCRIPTION	EACH	12/EA
A61780-7021	Coarse Turf, Light Green	\$4.85	\$4.36
A61780-7022	Coarse Turf, Medium Green	4.85	4.36
A61780-7023	Coarse Turf, Dark Green	4.85	4.36
A61780-1020	Fine Turf, Soil	4.85	4.36
A61780-4010	Fine Turf, Yellow Grass	4.85	4.36
A61780-7240	Green Grass, Fine Turf	4.85	4.36
A61780-7241	Green Grass, 25" x 33" Roll	12.94	11.63
A61780-1009	Ripplin' Water Kit	14.12	12.69



Midwest Products® Genuine Balsa Wood

Genuine balsa wood in various shapes and sizes.

Balsa Wood Sheets					
NUMBER	SIZE	PIECES	EACH	6/EA	
A33301-8201	1/32" x 3" x 36"	20	\$65.87	\$59.28	
A33301-3214	1/32" x 4" x 36"	20	96.23	86.60	
A33301-8203	3/32" x 3" x 36"	20	76.29	68.66	
A33301-8204	3/32" x 4" x 36"	15	82.91	74.61	
A33301-8202	1/16" x 3" x 36"	20	61.68	55.51	
A33301-1604	1/16" x 4" x 36"	20	95.25	85.73	
A33301-1603	3/16" x 3" x 36"	10	54.56	49.10	
A33301-3104	3/16" x 4" x 36"	10	76.29	68.66	
A33301-8204	1/8" x 3" x 36"	20	83.64	75.27	
A33301-1804	1/8" x 4" x 36"	15	91.95	82.76	
A33301-1806	1/8" x 6" x 36"	10	111.78	100.59	
A33301-1403	1/4" x 3" x 36"	10	63.70	57.33	
A33301-1404	1/4" x 4" x 36"	10	91.62	82.45	

Midwest Products® Genuine Basswood

Domestic wood cut in northern Michigan and Wisconsin. More sizes online.

Basswood Sheets					
NUMBER	SIZE	PIECES	EACH	6/EA	
A33300-2003	1/32" x 3" x 24"	15	\$27.80	\$25.03	
A33300-2004	1/32" x 4" x 24"	15	43.53	39.19	
A33300-3003	1/16" x 3" x 24"	15	29.54	26.60	
A33300-3004	1/16" x 4" x 24"	15	43.53	39.19	
A33300-4003	3/32" x 3" x 24"	15	33.04	29.74	
A33300-4004	3/32" x 4" x 24"	15	46.99	42.34	
A33300-5003	1/8" x 3" x 24"	15	38.29	34.47	
A33300-5004	1/8" x 4" x 24"	15	52.28	47.06	
A33300-6003	3/16" x 3" x 24"	10	31.36	28.22	
A33300-7004	1/4" x 4" x 24"	10	53.50	48.15	

Basswood Strips					
NUMBER	SIZE	PIECES	EACH	6/EA	
A33300-1251	1/8" x 3/32" x 24"	60	\$20.27	\$18.25	
A33300-2016	1/16" x 1/16" x 24"	60	20.27	18.25	
A33300-2018	1/16" x 1/8" x 24"	48	16.22	14.60	
A33300-2014	1/16" x 1/4" x 24"	42	23.98	21.59	
A33300-2118	1/8" x 1/8" x 24"	48	16.22	14.60	
A33300-2114	1/8" x 1/4" x 24"	30	17.13	15.42	
A33300-2012	1/16" x 1/2" x 24"	24	22.09	19.89	
A33300-2112	1/8" x 1/2" x 24"	15	17.31	15.58	
A33300-2032	3/32" x 3/32" x 24"	60	20.27	18.25	
A33300-3316	3/16" x 3/16" x 24"	36	20.55	18.50	
A33300-3014	3/16" x 1/2" x 24"	15	19.05	17.15	
A33300-3012	1/4" x 1/4" x 24"	20	18.41	16.57	
A33300-4038	3/8" x 3/8" x 24"	15	22.56	20.31	
A33300-4012	1/2" x 1/2" x 24"	10	23.19	20.87	



Creativity Street® Wooden Dowel Rods

Birchwood dowels are great for a variety of projects. Available in 12" and 36" lengths. Sold in packs of 12.

NUMBER	SIZE	EACH	12/EA
A60448-1412	1/4" Dia x 12"L	\$3.42	\$3.08
A60448-1436	1/4" Dia x 36"L	5.64	5.08
A60448-1212	1/2" Dia x 12"L	9.77	8.79
A60448-1236	1/2" Dia x 36"L	17.09	15.38
A60448-3812	3/8" Dia x 12"L	7.55	6.80
A60448-3836	3/8" Dia x 36"L	9.62	8.65

111 Piece Assortment — Includes 1/8" (34), 3/16" (20), 1/4" (17), 5/16" (15), 3/8" (13), and 1/2" (12).

All are 36" long.

NUMBER	EACH	6/EA
A60448-1111	\$52.94	\$47.64



Midwest Products® Square Basswood Dowels

Each bag contains 12, 12" long square dowels of varying thicknesses for a variety of craft, household, or outdoor uses.

NUMBER	EACH	12/EA
A33600-1001	\$5.85	\$5.27



Midwest Products® Mini Carving Block Bags

Mini carving block bags contain 72 cubic inches of basswood or balsa wood blocks in random sizes and shapes for a variety of carving projects.

NUMBER	DESCRIPTION	EACH	12/EA
A60415-1001	Balsa Wood	\$19.75	\$17.77
A60415-8514	Basswood	8.81	7.93

Midwest Products® Economy Wood Project Bag

Excellent for all types of modeling, craft, miniature, and woodworking projects. Packaged in poly bag of 72 cubic inches of basswood pieces (ranging from 5" to 7-7/8" long). Project ideas included.

NUMBER	EACH	12/EA
A60416-8480	\$9.63	\$8.67

HEALTH & SAFETY ICONS: ●=CL / ■=Prop 65 / ▼=CL & Prop 65 See page 644 for more information.

Midwest Products® Scale Lumber

This 11" long scale lumber is carefully machined from selected basswood, which is valued for its workability and finishing qualities. Cut thin pieces with a hobby knife, thicker pieces with a saw. For professional and student architectural modeling and structural analysis.

NUMBER	SIZE	PIECES	EACH	12/EA
A33304-2011	0.0208" x 0.125"	15	\$3.52	\$3.16
A33304-2027	0.0208" x 0.208"	17	3.52	3.16
A33304-2037	0.0208" x 0.0312"	17	3.52	3.16
A33304-2047	0.0208" x 0.0416"	17	3.52	3.16
A33304-2065	0.0208" x 0.0625"	15	3.52	3.16
A33304-2085	0.0208" x 0.0833"	15	3.52	3.16
A33304-4111	0.0416" x 0.1041"	15	3.52	3.16
A33304-4165	0.0416" x 0.0416"	15	3.52	3.16
A33304-4167	0.0416" x 0.0625"	15	3.52	3.16
A33304-4169	0.0416" x 0.0833"	15	3.52	3.16

356 graphic arts 800.447.8192 to order



Grafix Frisket Film

This transparent, matte masking film is essential for work that requires controlled application. Compatible with almost all surfaces, it's perfect for light protection, pre-cut stenciling, and on-the-artwork masking and cutting. It's easy to peel, leaves no residue on the board, and is backed by a translucent paper for ease in handling.

Sheets				
NUMBER	DESCRIPTION	EACH	6/EA	
A25200-2126	9" x 12" Pkg of 6	\$11.06	\$9.95	
A25200-2120	9" x 12" Pkg of 100	122.27	110.04	

Rolls				
NUMBER	DESCRIPTION	EACH	6/EA	
A25200-2124	12" x 4 yd	\$20.17	\$18.15	
A25200-2244	24" x 4 yd	36.73	33.06	
A25200-2240	24" x 10 yd	78.62	70.76	



Artool® Art Mask Frisk Films

These versatile, medium-tack masking films are solvent-proof, adhere to any surface, won't release even when retouch lacquer is applied, and won't lift up paint when removed. Use Art Mask for porous surfaces such as canvas, board, and paper. Stretch and Hobby are ideal for non-porous, curved, and irregular surfaces. Ultra is professional grade with maximum stretch.

NUMBER	DESCRIPTION	EACH	6/EA
A25204-1010	Art, 18" x 10 yd	\$39.87	\$35.89
A25204-1020	Art, 18" x 25 yd	90.49	81.46
A25204-1030	Stretch, 18" x 10 yd	38.03	34.24
A25204-1040	Stretch, 18" x 25 yd	69.25	62.34
A25204-1050	Hobby, 6" x 10 yd	24.92	22.43
A25204-1024	Ultra, 24" x 5 yd	110.17	99.17



Original Frisket Film

Create your own stencils or protect work from excessive handling. This low-tack, soft-peel, self-adhesive film can be used on most mediums and can easily be removed or repositioned.

Rolls				
NUMBER	DESCRIPTION	EACH	6/EA	
A25201-1015	Gloss, 15" x 4 yd	\$33.53	\$30.17	
A25201-1025	Gloss, 25" x 4 yd	68.80	61.92	
A25201-1154	Matte, 15" x 4 yd	33.53	30.17	
A25201-1254	Matte, 25" x 4 yd	68.80	61.92	

Sheets, 8 Pack				
NUMBER	DESCRIPTION	EACH	6/EA	
A25201-2015	Gloss, 15" x 10"	\$27.43	\$24.68	
A25201-3015	Matte, "15" x 10"	27.43	24.68	

WARNING! Products marked with a Prop 65 symbol (■ or ▼) can expose you to chemicals, including cadmium, which are known to the State of California to cause cancer and birth defects or other reproductive harm. For more information, visit P65Warnings.ca.gov.



Match Makers



Martini Time



Lucky 7



Angle Master

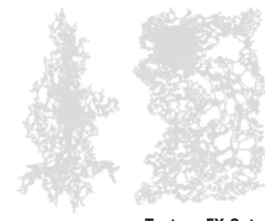

Texture FX Set of Three

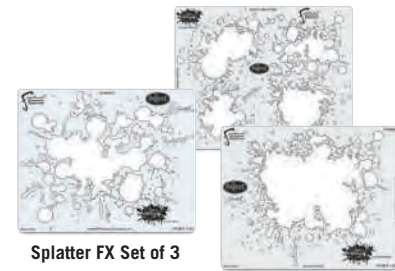

Splatter FX Set of 3

Artool® Freehand® Templates

An important creative tool for any airbrusher, with patterns designed by top airbrush artists. Flex or curve them easily around irregular-shaped surfaces. They clean up easily with solvents.

NUMBER	DESCRIPTION	EACH	5/EA
A25207-1005	Aces N' Eights	\$28.35	\$25.52
A25207-1171	Bubble FX	114.21	102.79
A25207-1012	Lucky 7	28.35	25.52
A25207-1015	Martini Time	28.35	25.52
A25207-1023	Match Makers	23.30	20.98
A25207-1173	Carbon Fiber FX Set of 2	34.18	30.76

NUMBER	DESCRIPTION	EACH	5/EA
A25207-1028	Angle Master	\$17.75	\$15.98
A25207-1081	Master Series Set of 2	26.99	24.32
A25207-1007	Skull Master Set of 3	74.07	66.67
A25207-1172	Splatter FX Set of 3	56.97	51.27
A25207-1024	Texture FX Set of 3	44.03	39.63
A25207-1127	Texture FX Mini Set of 3	22.78	20.50
A25207-1179	Texture FX2 Set of 3	39.97	35.97
A25207-1189	Texture FX2 Mini Set of 3	19.99	17.99
A25207-1020	Return of Skull Master Set of 4	98.73	88.86

Borden & Riley® Airbrush Pads

High-quality, pH-neutral paper, specifically made for airbrush applications. It enhances colors and is an affordable alternative to illustration board. Can be used for color separation work on laser scanning devices. 20 sheets per pad. 150 lb.



NUMBER	SIZE	EACH	6/EA
A12958-1003	9" x 12"	\$13.82	\$12.43
A12958-1005	11" x 14"	19.13	17.21
A12958-0001	19" x 24"	52.06	46.82



A-G Artool® Freehand™ Shields

These shields are great tools for creating spontaneous effects. They provide multiple masking combinations and options to make your work easier and faster. For cleanup, simply wipe off the solvent-proof template with airbrush cleaner.

NUMBER	DESCRIPTION	EACH	5/EA
A26927-1001	A FH-1	\$16.93	\$15.23
A26927-1002	B FH-2	16.93	15.23
A26927-1360	C FH-3, The 360° Shield	16.93	15.23
A26927-1045	D FH-4, The 45° Shield	16.93	15.23
A26927-1003	E FH-5, The Mini Shield	16.93	15.23
A26927-1004	F FH-6, The Super Shield	16.93	15.23
A26927-1005	G FH-7, The Big Shield	16.93	15.23

Set of 7 — Includes one each of the above.

NUMBER	EACH	3/EA
A26927-1070	\$109.96	\$98.97

Jacquard® Airbrush Paints

A rich, stunning paint specially formulated for airbrushing on any surface including fabric, leather, wood, plastic, and metal. Once dry, it is permanent, indelible in water, and acid-free. Colors are bright, clear, intermixable, and airbrush like a dream. Certified non-toxic. **Colors can be assorted for quantity pricing.**



4 oz (118 ml) Bottles

NUMBER	COLOR	EACH	6/EA
A25325-5484	Bright Blue	\$7.21	\$6.49
A25325-7254	Bright Green	7.21	6.49
A25325-6044	Bright Lavender	7.21	6.49
A25325-4514	Bright Orange	7.21	6.49
A25325-6074	Bright Purple	7.21	6.49
A25325-3074	Bright Red	7.21	6.49
A25325-5114	Bright Turquoise	7.21	6.49
A25325-4294	Bright Yellow	7.21	6.49
A25325-5244	Fluor Blue	7.21	6.49
A25325-7274	Fluor Green	7.21	6.49
A25325-3484	Fluor Hot Pink	7.21	6.49
A25325-4564	Fluor Orange	7.21	6.49
A25325-3364	Fluor Raspberry	7.21	6.49
A25325-3214	Fluor Red	7.21	6.49
A25325-4544	Fluor Sunburst	7.21	6.49
A25325-6914	Fluor Violet	7.21	6.49
A25325-4224	Fluor Yellow	7.21	6.49
A25325-3894	Irid Apple Red	7.21	6.49
A25325-5814	Irid Electric Blue	7.21	6.49
A25325-7924	Irid Green	7.21	6.49
A25325-3744	Irid Red	7.21	6.49
A25325-3084	Irid Scarlet	7.21	6.49
A25325-5184	Irid Teal	7.21	6.49
A25325-6924	Irid Violet	7.21	6.49
A25325-4364	Irid Yellow	7.21	6.49
A25325-5544	Metallic Blue	7.21	6.49
A25325-9514	Metallic Copper	7.21	6.49
A25325-3714	Metallic Red	7.21	6.49
A25325-9324	Metallic Silver	7.21	6.49
A25325-9124	Metallic Solar Gold	7.21	6.49
A25325-9024	Metallic True Gold	7.21	6.49
A25325-1294	Metallic White	7.21	6.49
A25325-4764	Metallic Yellow	7.21	6.49
A25325-2214	Opaque Black	7.21	6.49
A25325-5914	Opaque Blue	7.21	6.49
A25325-7914	Opaque Green	7.21	6.49
A25325-3724	Opaque Red	7.21	6.49
A25325-8084	Opaque Sepia	7.21	6.49
A25325-6714	Opaque Violet	7.21	6.49
A25325-1084	Opaque White	7.21	6.49
A25325-4924	Opaque Yellow	7.21	6.49
A25325-2024	Transparent Black	7.21	6.49
A25325-5664	Transparent Blue	7.21	6.49
A25325-8914	Transparent Brown	7.21	6.49
A25325-7424	Transparent Green	7.21	6.49
A25325-3734	Transparent Red	7.21	6.49
A25325-6514	Transparent Violet	7.21	6.49
A25325-1734	Transparent White	7.21	6.49
A25325-4554	Transparent Yellow	7.21	6.49

Jacquard Airbrush Packs — Nine 0.5 oz (15 ml) bottles per set. For colors, visit DickBlick.com.

NUMBER	DESCRIPTION	EACH	6/EA
A25325-1010	Opaque Exciter Pack	\$20.27	\$18.25
A25325-1020	Metallic Exciter Pack	20.27	18.25
A25325-1030	Transparent Exciter Pack	20.27	18.25

Sneaker Series Colors — Specially formulated colors for retouching and customizing sneakers. 4 oz (118 ml) bottles.

NUMBER	COLOR	EACH	6/EA
A25325-2504	Concrete Gray	\$7.86	\$7.06
A25325-3124	Fire Red	7.86	7.06
A25325-4864	Gamma Blue	7.86	7.06
A25325-1024	Miami	7.86	7.06
A25325-6094	Military Green	7.86	7.06
A25325-5044	Navy	7.86	7.06
A25325-8924	Tanned Leather	7.86	7.06
A25325-1014	Volt	7.86	7.06

Badger® Spectra Tex™ Airbrush Colors

Specially formulated to meet the needs of the professional airbrush artist, these clean, bright colors are ready to use on fabric, wood, canvas, and more, with permanent results. The waterbased, low-viscosity formula requires no dilution and has outstanding flow characteristics, virtually eliminating tip dry. Low odor; no harmful solvents. **Colors can be assorted for quantity pricing.**



Transparent Colors, 2 oz (59 ml) Bottles

NUMBER	COLOR	EACH	6/EA
A25335-1013	Adobe	\$6.06	\$5.45
A25335-5363	Aquamarine	6.06	5.45
A25335-8143	Biege	6.06	5.45
A25335-4513	Bright Orange	6.06	5.45
A25335-5063	Brilliant Blue	6.06	5.45
A25335-4933	Brilliant Yellow	6.06	5.45
A25335-8623	Buff	6.06	5.45
A25335-3143	Burgundy	6.06	5.45
A25335-5083	California Teal	6.06	5.45
A25335-3093	Classic Red	6.06	5.45
A25335-3703	Cranberry	6.06	5.45
A25335-3393	Creamy Peach	6.06	5.45
A25335-3163	Crimson Red	6.06	5.45
A25335-5593	Cyan Blue	6.06	5.45
A25335-8033	Dark Brown	6.06	5.45
A25335-7033	Dark Green	6.06	5.45
A25335-7183	Dark Green	6.06	5.45
A25335-3753	Flag Red	6.06	5.45
A25335-6093	Grape	6.06	5.45
A25335-7363	Kelly Green	6.06	5.45
A25335-8013	Light Brown	6.06	5.45
A25335-7233	Lime Green	6.06	5.45
A25335-5803	Midnight Navy	6.06	5.45
A25335-8323	Mocha Brown	6.06	5.45
A25335-7523	Moss Green	6.06	5.45
A25335-5793	Pacific Blue	6.06	5.45
A25335-7783	Parrot Green	6.06	5.45
A25335-5193	Patriot Blue	6.06	5.45
A25335-6173	Plum Royal	6.06	5.45
A25335-5913	Powder Blue	6.06	5.45
A25335-3713	Rose Petal Pink	6.06	5.45
A25335-5053	Royal Blue	6.06	5.45
A25335-3763	Royal Fuchsia	6.06	5.45
A25335-3083	Scarlet Red	6.06	5.45
A25335-2693	Shadow Gray	6.06	5.45
A25335-5313	Slate Blue	6.06	5.45
A25335-4393	Sun Gold	6.06	5.45
A25335-2793	Thunder Gray	6.06	5.45
A25335-4963	Thunder Orange	6.06	5.45
A25335-1713	Tint White	6.06	5.45
A25335-5113	Turquoise	6.06	5.45
A25335-6513	Violet	6.06	5.45
A25335-2903	Wrought Iron Gray	6.06	5.45
A25335-4113	Yellow Oxide	6.06	5.45

Opaque Colors, 2 oz (59 ml) Bottles

NUMBER	COLOR	EACH	6/EA
A25335-4923	Coral Orange	\$6.06	\$5.45
A25335-7913	Green	6.06	5.45
A25335-1093	Intense White	6.06	5.45
A25335-2043	Jet Black	6.06	5.45
A25335-4063	Lemon Yellow	6.06	5.45
A25335-6003	Purple	6.06	5.45
A25335-3723	Red	6.06	5.45
A25335-5073	Sky	6.06	5.45

Metallic Colors, 2 oz (59 ml) Bottles

NUMBER	COLOR	EACH	6/EA
A25335-5543	Blue	\$6.39	\$5.75
A25335-8153	Bronze	6.39	5.75
A25335-8813	Copper	6.39	5.75
A25335-9023	Gold	6.39	5.75
A25335-7843	Green	6.39	5.75
A25335-6413	Purple	6.39	5.75
A25335-3733	Red	6.39	5.75
A25335-9323	Silver	6.39	5.75
A25335-1593	White	6.39	5.75
A25335-4763	Yellow	6.39	5.75

Neon Fluorescent Colors, 2 oz (59 ml) Bottles

NUMBER	COLOR	EACH	6/EA
A25335-2293	Neon Black Light	\$6.06	\$5.45
A25335-5303	Neon Blue	6.06	5.45
A25335-7773	Neon Green	6.06	5.45
A25335-4663	Neon Lemon	6.06	5.45
A25335-4683	Neon Orange	6.06	5.45
A25335-3623	Neon Pink	6.06	5.45
A25335-6443	Neon Purple	6.06	5.45
A25335-6453	Neon Prpl Berry	6.06	5.45
A25335-3743	Neon Red	6.06	5.45
A25335-3773	Neon Wild Berry	6.06	5.45

Iwata Com-Art Colors

Com-Art Colors are specially formulated for airbrushing and never need filtering or straining. Heavily pigmented and lightweight, they provide superior atomization and smooth spraying. They also dry instantly. Opaque and transparent colors can be mixed without any color bleed or show-through. **Colors can be assorted for quantity pricing.**



Opaque Colors, 1 oz (30 ml) Bottles

NUMBER	COLOR	EACH	12/EA
A25326-4451	Azo Yellow	\$5.50	\$4.95
A25326-5911	Azure Blue	5.50	4.95
A25326-2211	Black	5.50	4.95
A25326-5101	Blue Green	5.50	4.95
A25326-5391	Blue Violet	5.50	4.95
A25326-4921	Bright Orange	5.50	4.95
A25326-3711	Bright Rose	5.50	4.95
A25326-8151	Bronze Metallic	5.50	4.95
A25326-8041	Burnt Sienna	5.50	4.95
A25326-8051	Burnt Umber	5.50	4.95
A25326-3151	Carmine	5.50	4.95
A25326-7451	Chrome Green	5.50	4.95
A25326-4671	Citron Yellow	5.50	4.95
A25326-5181	Cobalt Blue	5.50	4.95
A25326-7671	Cobalt Green Hue	5.50	4.95
A25326-3721	Deep Red	5.50	4.95
A25326-4321	Deep Yellow	5.50	4.95
A25326-9021	Gold Metallic	5.50	4.95
A25326-4971	Hansa Yellow	5.50	4.95
A25326-3041	Magenta	5.50	4.95
A25326-3341	Maroon	5.50	4.95
A25326-5161	Phthalo Blue	5.50	4.95
A25326-7801	Phthalo Green	5.50	4.95
A25326-3271	Quinacridone Red	5.50	4.95
A25326-8061	Raw Sienna	5.50	4.95
A25326-8071	Raw Umber	5.50	4.95
A25326-3121	Red Oxide	5.50	4.95
A25326-7091	Sap Green	5.50	4.95
A25326-9331	Silver Metallic	5.50	4.95
A25326-5191	Turquoise	5.50	4.95
A25326-3281	Vermilion	5.50	4.95
A25326-6711	Violet	5.50	4.95
A25326-1081	White	5.50	4.95

Transparent Colors, 1 oz (30 ml) Bottles

NUMBER	COLOR	EACH	12/EA
A25326-2131	Black	\$5.50	\$4.95
A25326-3171	Bright Red	5.50	4.95
A25326-4201	Cadmium Yellow	5.50	4.95
A25326-3351	Carmine	5.50	4.95
A25326-7051	Emerald	5.50	4.95
A25326-7271	Forest Green	5.50	4.95
A25326-3441	Magenta	5.50	4.95
A25326-7521	Moss Green	5.50	4.95
A25326-4041	Ochre	5.50	4.95
A25326-4961	Orange	5.50	4.95
A25326-3771	Rose	5.50	4.95
A25326-5051	Royal Blue	5.50	4.95
A25326-8121	Sienna Brown	5.50	4.95
A25326-5241	Ultramarine	5.50	4.95
A25326-3381	Vermilion	5.50	4.95
A25326-6551	Violet	5.50	4.95
A25326-7891	Viridian	5.50	4.95

1 oz (30 ml) Sets — For colors, visit DickBlick.com.

NUMBER	DESCRIPTION	EACH	6/EA
A25326-1019	Opaque Primary Set of 10	\$35.55	\$31.99
A25326-1029	Opaque Secondary Set of 10	35.55	31.99
A25326-1059	Opaque and Transparent Colors, Set of 10	35.55	31.99



Badger® Air-Opaque Primary Set

Set of seven colors includes 1 oz (30 ml) plastic squeeze bottles of Black, Blue, Brown, Crimson, Green, White, and Yellow.

NUMBER	EACH	6/EA
A25305-1009	\$31.79	\$28.61

CREATEX®

Creutex® Airbrush Colors

Designed for textiles and most applications, including wood, leather, ceramics, canvas, aluminum, glass, fingernail art, and more, all colors are waterbased, intermixable. **Colors can be assorted for quantity pricing.**



Transparent Colors

COLOR	4 OZ (120 ML)	EACH	12/EA	16 OZ (473 ML)	EACH	12/EA
Aqua	A25308-5254	\$7.54	\$6.79	A25308-5256	\$29.39	\$26.44
Black	A25308-2014	7.54	6.79			
Brite Blue	A25308-5764	7.54	6.79	A25308-5766	29.39	26.44
Brite Green	A25308-7014	7.54	6.79	A25308-7016	29.39	26.44
Brite Red	A25308-3304	7.54	6.79	A25308-3006	29.39	26.44
Brite Yellow	A25308-4104	7.54	6.79	A25308-4106	29.39	26.44
Burgundy	A25308-3144	7.54	6.79	A25308-3146	29.39	26.44
Canary Yellow	A25308-4264	7.54	6.79	A25308-4266	29.39	26.44
Caribbean Blue	A25308-5914	7.54	6.79	A25308-5916	29.39	26.44
Dark Brown	A25308-8034	7.54	6.79	A25308-8036	29.39	26.44
Deep Blue	A25308-5464	7.54	6.79	A25308-5466	29.39	26.44
Deep Red	A25308-3714	7.54	6.79	A25308-3716	29.39	26.44
Flamingo Pink	A25308-3064	7.54	6.79	A25308-3066	29.39	26.44
Forest Green	A25308-7804	7.54	6.79	A25308-7806	29.39	26.44
Fuchsia	A25308-6134	7.54	6.79	A25308-6136	29.39	26.44
Gray	A25308-2614	7.54	6.79	A25308-2616	29.39	26.44
Leaf Green	A25308-7154	7.54	6.79	A25308-7156	29.39	26.44
Light Brown	A25308-8014	7.54	6.79	A25308-8016	29.39	26.44
Maui Blue	A25308-5794	7.54	6.79	A25308-5796	29.39	26.44
Orange	A25308-4604					

Badger airbrushes: features at a glance

Model	Usage	Paint Delivery	Nozzle Size	Standout Features
Badger Model 350 *Single Action	Beginners, Hobby, Ceramics, Craft, Automotive	Bottom; 1/4 oz, 3/4 oz, and 2 oz cups	.50 mm, .75 mm, and 1 mm	External mix; sprays higher viscosity materials; excellent for larger projects
Badger Model 150 Professional	Craft, Fine Art, Taxidermy, Automotive, Furniture, Technical, Illustration	Bottom; 1/4 oz, 3/4 oz, and 2 oz cups	.22 mm, .50 mm, and .75 mm	Badger's "classic" airbrush; versatile for a broad range of applications
Badger Model 155 Anthem	Automotive, Cosmetics, Acrylic, Hobby, T-Shirts	Bottom; 3/4 oz cup	.33 mm	Comfortable, reliable, and user-friendly; unique needle/tip assembly enables a single needle to spray virtually any material

*All airbrushes listed in this chart are dual action unless noted.

A Badger® Model 350 Single Action Airbrush Set

A great set for spraying thicker paints and glazes. It includes the Model 350 Airbrush with a medium tip, fine and heavy fluid assemblies, two jars, a color cup, an air hose, a wrench, and instructions. For details, visit DickBlick.com.

NUMBER A25026-1009 EACH \$99.72 3/EA \$89.74

B Badger® Model 150 Professional Double Action Airbrush Set

A versatile set, with three different head assemblies and needles so you can spray virtually any type of material. Set includes the Model 150 Airbrush with a medium head, extra-fine and heavy-duty head assemblies with needles, two jars, a color cup, an air hose, a wrench, protective cap, pipe thread fitting, and instructions. For details, visit DickBlick.com.

NUMBER A25002-0100 EACH \$158.65 3/EA \$142.79

C Badger® Model 155 Anthem® Double Action Airbrush Set

With Badger's convenient Model 155, there's no need for separate tips to spray different materials and consistencies. A single needle can spray it all. The set includes the Model 155 Airbrush, three jars, a jar adapter, a color cup, an air hose, and instructions. For details, visit DickBlick.com.

NUMBER A25022-1009 EACH \$174.08 3/EA \$156.67

D Grex Genesis XT Airbrush Combo Kit

Kit includes the Genesis XT airbrush with 7 ml (1/4 oz) and 15 ml (1/2 oz) side gravity cups, AC1810 air compressor, 6 ft nylon braided air hose, side siphon attachment with 30 ml (1 oz) bottle, G-MAC air control valve with quick disconnect, airbrush nozzle wrench, and airbrush carrying case. For details, visit DickBlick.com.

NUMBER A25087-1001 EACH \$490.00 3/EA \$440.00

Iwata airbrushes: features at a glance

Model	Usage	Paint Delivery	Nozzle Size	Standout Features
Neo Series CN	Illustration, Beginner, Hobby	Gravity; 1/3 oz and 1/16 oz cups	.35 mm	A versatile, affordable option for first-time users; sprays thin to medium fluids
Neo Series BCN	Hobby, T-Shirts, Beginner	Bottom; 1 oz bottle	.50 mm	
Eclipse Series HP-BCS	Automotive, Body Art, Acrylic, Hobby, Mural, T-Shirts, Ceramics, Signage	Bottom; 2 oz bottle	.50 mm	Built for multipurpose; sprays thin to medium fluids
Eclipse Series HP-SBS	Automotive, Fine Art, Body Art, Hobby	Side; 1/8 oz cup	.35 mm	
Eclipse Series HP-CS	Fine Art, Hobby, Ceramics, Cosmetics, Craft, Signage	Gravity; 1/3 oz cup	.35 mm	For fine-detail spraying with high paint-flow capacity; can handle heavier fluids
HP Plus Series HP-B Plus	Illustration, Nail Art, Watercolor, Figurines	Gravity; 1/16 oz cup	.20 mm	Pro-grade airbrush with cutaway handle and larger threads on nozzle for a more secure fit and better needle centering; consistent performance; great for fine detail
HP Plus Series HP-BC Plus	Automotive, Fine Art, Figurines	Bottom; 3/4 oz bottle	.30 mm	
HP Plus Series HP-C Plus	Cosmetics, Acrylic, Hobby, Watercolor, Fine Art	Gravity; 1/3 oz cup	.30 mm	

*All airbrushes listed in this chart are dual action unless noted.



Neo for Iwata® Gravity-Feed Airbrushing Kit

Everything you need to get started with airbrush art. It includes the versatile Neo CN Airbrush, a Neo Air Compressor, color cups, cleaner, acrylic paint, and a link to online practice tools. A great kit for model painting, illustration, and more.

NUMBER A25988-1009 EACH \$247.91



Iwata® Beginner Airbrush Set

A carefully chosen assortment of Iwata's best equipment for first-time users, this set has everything you need to start producing impressive results right out of the box. It includes the Neo CN Gravity Feed Dual Action Airbrush, the lightweight Ninja Jet Compressor, airbrush colors, and other supplies, plus Robert Paschal's book "Basic Airbrush Techniques: A Complete Course." For complete details, visit DickBlick.com.

NUMBER A25403-1001 EACH \$320.00



Iwata® Neo Series Airbrushes

NUMBER	DESCRIPTION	EACH
A25092-1010	CN	\$97.13
A25092-1020	BCN	107.35



Iwata® Eclipse Series

NUMBER	DESCRIPTION	EACH
A25025-1009	HP-BCS	\$147.87
A25025-1010	HP-SBS	198.48
A25025-1030	HP-CS	198.48



Iwata® HP Plus Series

NUMBER	DESCRIPTION	EACH
A25066-1020	HP-B Plus	\$258.75
A25066-1030	HP-BC Plus	322.00
A25066-1040	HP-C Plus	258.75

BLICK®

Blick® Airbrush Essentials Kit by Badger®

A kit for beginners looking to try a variety of airbrushing projects. Includes the Badger Model 150 Airbrush, plus a compressor, paints, instructional DVD, and more. For full details, visit DickBlick.com.

NUMBER A25983-0150 EACH \$593.00



Master Airbrush Cleaning Kit

Everything you need for good maintenance of your airbrushes. Includes: 9-piece micro needle set with handle, 5-piece precision mini brush set, 2-piece precision end brush set with handle, 1/4" nylon twisted brush, a nylon exterior brush in a protective plastic tube, and more.

NUMBER A26902-1010 EACH \$46.73 6/EA \$42.05



Iwata® Airbrush Cleaning Kit

Unique tools and expert guidance for cleaning and maintaining any brand or style of airbrush. Includes Iwata Medea Airbrush Cleaner, nozzle wrench, thread sealer, LED magnifier to see parts up close, two extra-small cleaning brushes, washing brush, 50 non-shredding pipe cleaners, lube, storage case, and instructions.

NUMBER A52879-1001 EACH \$35.80

BLICK® complete airbrush system

Blick® Complete Airbrush System by Iwata®

Put together with the pros at Iwata, this expansive kit features one of the most versatile airbrushes in the industry — the Iwata Eclipse HP-CS. This high-paint-flow, high-detail airbrush has established a new benchmark for excellence in an all-purpose airbrush. The zero-maintenance, oil-less compressor never needs lubrication. For complete details, visit DickBlick.com.

NUMBER A26973-1019 EACH \$597.00

includes:

- Iwata Eclipse HP-CS Gravity Feed Airbrush
- Iwata Oil-less Compressor
- Set of 5 Com-Art Airbrush Paints
- 1 oz Bottle of Iwata Medea Airbrush Cleaner
- 0.68 oz bottle of Iwata Medea Super Lube
- Iwata nozzle wrench



all for one low price!

- Iwata 30X/60X LED magnifier
- 2 Extra-small cleaning brushes
- 50 Non-shedding pipe cleaners
- Washing Brush
- Storage case
- Instructional brochure

PAASCHE

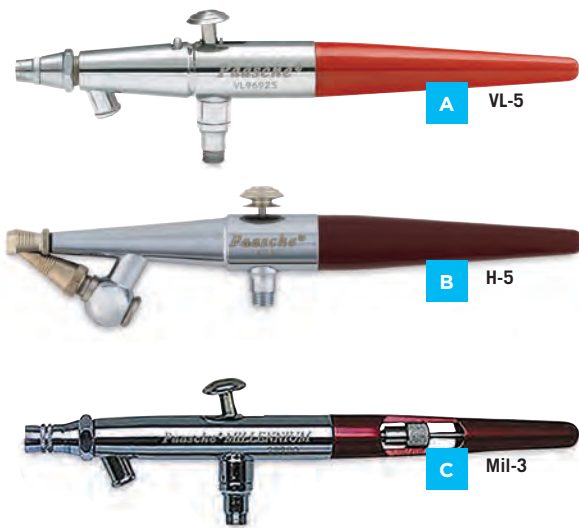

Paasche airbrushes: features at a glance

Model	Usage	Paint Delivery	Nozzle Size	Standout Features
Model VL-1	Automotive, Hobby, Signs, Taxidermy, Cake Decorating, T-Shirts, Cosmetics, Fine and Commercial Art	Bottom; no cup included	.55 mm	A favorite of auto and T-shirt artists; internal mix; left- or right-handed use
Model VL-3			.73 mm	
Model VL-5			1.06 mm	
Model H-1 *Single Action	Automotive, Hobby, Signs, Taxidermy, Cake Decorating, Fine and Commercial Art	Bottom; no cup included	.45 mm	A popular airbrush for beginners; easy to own and use; sturdy and flexible
Model H-3 *Single Action			.64 mm	
Model H-5 *Single Action			1.06 mm	
Millennium Mil-3	Automotive, Hobby, Signs, Taxidermy, Cake Decorating, Nail Art, T-Shirts, Fine and Commercial Art	Bottom; 1/4 oz cup	.73 mm	Durable body with cut-away handle; rounded trigger button offers greater comfort and control

*All airbrushes listed in this chart are dual action unless noted.

A Paasche Model VL Double Action Airbrush

NUMBER	DESCRIPTION	EACH	6/EA
A25010-0400	VL-1 without Accessories	\$93.69	\$84.32
A25010-0500	VL-3 without Accessories	93.69	84.32
A25010-0600	VL-5 without Accessories	93.69	84.32



Paasche Model VL Airbrush Set — Everything you need to get started! The set contains head/needle assemblies in three different sizes (allowing you to spray light and medium spray patterns from 1/64" to 1-1/2"), plus 1/4 oz (7 ml) color cup, 1 oz (30 ml) plastic bottle and cap, hanger, wrench, 6 ft of 1/8" air hose with couplings, 1 oz (30 ml) plastic bottle complete, 3 oz (89 ml) plastic bottle, and a lessons booklet.

NUMBER	EACH	6/EA
A25010-0300	\$119.77	\$107.79

B Paasche Model H Single Action Airbrush

NUMBER	DESCRIPTION	EACH	6/EA
A25005-0300	H-1 without Accessories	\$62.27	\$56.05
A25005-0400	H-3 without Accessories	62.27	56.05
A25005-0500	H-5 without Accessories	62.27	56.05



Paasche Model H Airbrush Set — This set contains everything you need, ready to hook up to a compressor, including a Model H Airbrush with all three air caps and color-adjusting parts for easy conversion to different sizes, 1/4 oz (7-1/3 ml) metal color cup, 1 oz (30 ml) color plastic bottle assembly, 1 oz (30 ml) plastic bottle and cap, hanger, wrench, 6 ft of 1/8" air hose with couplings, and a lessons booklet.

NUMBER	EACH	3/EA
A25005-0600	\$92.08	\$82.87

C Paasche Millennium Mil-3 Airbrush

Features a thin barrel grip and cutaway red anodized handle that allows quick pullback of needle mechanism to blow out clogs. Round trigger button rolls under your finger for greater comfort and better control.

NUMBER	EACH	6/EA
A25012-0000	\$89.68	\$80.70



Mil-3 Airbrush Set — The Millennium Airbrush and these accessories: protecting cap, 1/4 oz (7 ml) metal color cup, 1/2 oz (15 ml) plastic bottle assembly, wrench, hanger, 6 ft of 1/8" air hose with couplings, and a lessons booklet.

NUMBER	EACH	6/EA
A25012-0100	\$116.37	\$104.73

CRAFTWELL



Craftwell eBrush Airbrush System

Turn any marker into an airbrush! Simply insert a marker into the appropriate brand-specific adapter to create stunning art quickly and easily — perfect for urban artists and crafters on the go. This pro-quality system includes the eBrush, a portable compressor, six marker adapters, and more. For details, visit DickBlick.com.

NUMBER	DESCRIPTION	EACH
A26993-1001	eBrush System	\$182.97
A26993-1006	Chartpak Ad Adapter	10.99
A26993-1003	Copic Adapter	10.99
A26993-1007	Prismacolor Adapter	10.99
A26993-1008	Rechargeable Battery	55.10
A26993-1004	Sharpie Adapter	10.99
A26993-1002	Spectrum Noir Adapter	10.99
A26993-1005	Tombow Adapter	10.99



Sparmax Beetle Airbrush Compressor

Sleek, small, and lightweight, yet powerful — perfect for on-the-go airbrushing. It operates at 40 decibels and has a preset maximum pressure of 30 PSI and an airflow of approximately 0.49 CFM/14 LPM at open flow and 0.21 CFM at 10 PSI. It also has a "Smart Stop" automatic shut-off. Includes an AC adapter, a detachable airbrush holder, a detachable power cord and plug, and a 4M PU curly hose. Measures 4-1/2"H x 4"W x 4-3/4"L and weighs 1.35 lb.

NUMBER	EACH
A25798-1001	\$233.41



Badger Airstorm Compressor

Portable yet powerful, this maintenance-free, 1/6 HP compressor features an on/off toggle switch, auto shut-off, a hinged handle, and a 6 ft power cord. It's excellent for moderate frequency use. Accepts a 1/4" hose. Maximum PSI is 57 lb. Weighs 8 lb.

NUMBER	EACH
A25135-1001	\$301.00



Badger TC908 Aspire Compressor

This lightweight (8 lb) 1/6 HP compressor puts out a maximum pressure of 57 PSI and requires no lubrication, offering maintenance-free use for all airbrush applications. It features a 1/8" hose connection, air regulator, gauge, moisture trap, and on/off toggle switch. Includes 1/4" hose adapter.

NUMBER	EACH
A25137-9080	\$299.89



Paasche D500 and D500SR Compressors

These economical, oil-less, one-phase 60Hz piston compressors are suitable for all airbrushes spraying properly thinned fluids. The D500 delivers 20-40 PSI operating pressure depending on the airbrush used and weighs 8 lb. The D500SR includes an R-75 Regulator/Filter with gauge, which regulates up to 40 PSI, depending on usage (intermittent or constant) and airbrush size. Weighs 9 lb.

NUMBER	DESCRIPTION	EACH
A25112-0110	D500	\$144.22
A25112-1018	D500SR	164.33



Power Jet Lite



Power Jet Pro



Smart Jet



Sprint Jet

Iwata Studio Compressors

Iwata offers a range of compressors to meet a range of studio needs. From very basic to very powerful, these compressors are reliable and quiet. All models feature a low-maintenance, oil-less piston motor, and a high-strength polyurethane air hose. For complete details about the models shown, visit DickBlick.com.

NUMBER	DESCRIPTION	EACH	NUMBER	DESCRIPTION	EACH
A25048-1004	Power Jet Lite	\$423.00	A25048-1002	Smart Jet	\$317.00
A25048-1007	Power Jet Pro	583.00	A25048-1001	Sprint Jet	256.99



A Shain® Painting Hood and Cabinet System

Fabricated of 18 gauge steel with a corrosion-resistant, powder-coated, baked epoxy finish. The painting hood includes a standard vapor-proof light and two filters, with a blower motor that operates at an RPM designed to provide 100 LFM and approximately 3/4" of static pressure. It rests atop a maple base cabinet with locking doors and an adjustable shelf. Both the light and the blower can be pre-wired to switches in the front post area of the booth when required. The booth must be connected to duct work (not provided). Made in the USA using all CARB-compliant materials. Durable, water-resistant, chemical-resistant, and environmentally friendly finish. Measures 97-3/4"H x 36"W x 24"D. Limited lifetime warranty. Truck Shipment and FOB Factory. See page 648 for details.

NUMBER	EACH
AF26987-1001	\$6165.00

B Laguna® Pro-X Seamless Spray Booth

This uni-cast, modular polyethylene unit is an economical and environmentally sound choice when spraying paints or glazes. Because it has no seams, it's easy to clean. Quality construction — won't rust, corrode, or discolor. Features a built-in filter bracket for holding either two Styrofoam™ spray filters or two aluminum baffle filters. Filter styles are interchangeable, cleanable, and reusable; use of two filters of either style are required with the Pro-X. (The aluminum baffle filter has a longer use life before cleaning is required.) Overspray is funneled into your recovery tank, saving valuable material while protecting the environment. 34-1/2"H x 27-1/2"W x 30"D interior work area; optional 1"H x 29"W x 12"D interior stainless steel shelf is available. 47-1/2"H x 30-3/4"W x 34"D exterior dimensions (includes exhaust motor mount on rear) means you can fit it through a standard doorway opening. Set it on a tabletop or on the optional stainless steel stand with casters, which measures 30"H x 31"W x 34-1/4"D. Weighs 120 lb. Truck Shipment and FOB Factory. See page 648 for details.

NUMBER	ACCESSORIES	EACH
AF30253-1001	Pro-X Booth	\$932.00
AF30254-1006	Pro-X Stand with Casters	196.99
AF30254-1004	1187 CFM Exhaust Fan	825.00
AF30254-1001	Stainless Steel Shelf	107.55
AF30254-1002	Reusable Styrofoam Filter	22.92
AF30254-1003	Aluminum Baffle Filter	49.13



HomeRight Spray Shelters

These lightweight, portable shelters provide a dedicated space for painting with spray cans or paint sprayers, effectively reducing overspray drift. They have a curved three-sided design. Easy to set up and take down. Storage bag included. For more details, visit DickBlick.com.

NUMBER	DESCRIPTION	SIZE	EACH
A27278-1001	Small	30"D x 36"W x 39"H	\$35.43
A27278-1003	Medium	56"D x 55"W x 66"H	50.58
A27278-1002	Large	72"D x 102"W x 66-1/2"H	60.69

Paasche® Hobby Shop Spray Booth

This portable booth is rugged, compact in size, and easy to assemble. Features galvanized metal for easy cleaning and durability. Uses a carbon and fiberglass filter system. Intended for removal of large particles from the air but will not remove all hazardous materials. Must be vented to outside with 4" dryer duct when spraying materials with strong vapors or harmful chemicals. Equipped with three-wire cord, 115V, 60-cycle, single-phase motor. 22"H x 18"W. Weighs 30 lb. FOB Factory. See page 648 for details.

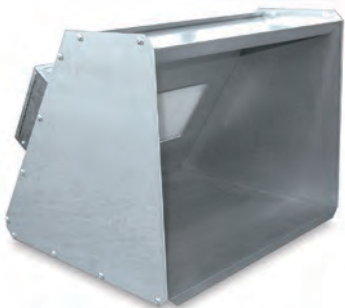

NUMBER	EACH
AF26908-0000	\$433.00

SIMair™ Brushless Uni-Booth

The Uni-Booth is a powerful filtration system for workshops, studios, and industrial situations where fumes and overspray present a problem. It uses a centrifugal blower/motor with a polyester intake filter for trapping fine particulate materials and a dual-activated charcoal filter for greater solvent and odor removal. Easy-to-assemble steel cabinet surround has a clear-cast acrylic top, allowing light onto the subject to be sprayed. Four-position hanging bar for suspending items for spraying. A removable polypropylene liner is supplied for easy cleaning. Overall dimensions of the Uni-Booth: 26"H x 28"W x 26"D. Weighs 39 lb. FOB Factory. See page 648 for details.

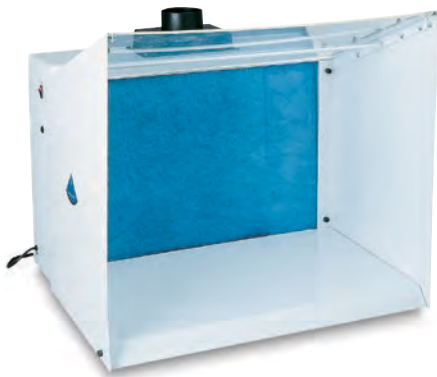

NUMBER	DESCRIPTION	EACH
AF52911-1000	Uni-Booth	\$2799.00
A52959-0100	Replacement Intake Filter	81.69
A52959-1001	Replacement Charcoal Filter, Pack of 2	181.98

Got a question about a product?
Our experts have the answer!
Three ways to connect —

Live Chat at DickBlick.com, call
800.933.2542, or email info@DickBlick.com.



How to Create Your Own Gig Posters, Band T-Shirts, Album Covers, and Stickers

Make cool and creative band merchandise. Follow along with step-by-step instructions and photos. Learn techniques including screen printing, mixed media collage, stenciling, and other guerrilla art styles. The included gallery of art provides great inspiration. Ruthann Godollei. Paperback. 160 pages. 8-1/2" x 11".

NUMBER	EACH
A70810-1001	\$26.49



Yellow Owl Workshop's Make It Yours

Patterns and Inspiration to Stamp, Stencil, and Customize Your Stuff

Yellow Owl Workshop founder Christine Schmidt shares her trade secrets for creating gorgeous, personalized projects using unexpected materials. Best of all, you can mix and match the book's templates and techniques to create countless more projects! The book features inventive ideas for every room, skill level, and time constraint. Christine Schmidt. 192 pages. 8-1/2" x 10".

NUMBER	EACH
A69398-1001	\$23.09



Print & Stamp Lab

52 Ideas for Handmade, Upcycled Print Tools
Readers learn to create 52 print blocks and stamp tools, all from inexpensive, ordinary, and unexpected materials — string, spools, flip flops, ear plugs, rubber bands, school erasers, and a slew of other repurposed and upcycled items. The book also shows how to use those simple tools to make multi-layered prints and patterns. Traci Bunkers. Paperback. 144 pages. 8-1/2" x 8-1/2".

NUMBER	EACH
A70741-1001	\$25.11



NEW! Gelli Arts Printing Guide

This expanded edition teaches how to use Gelli plates to print on paper and fabric quickly and easily without traditional gelatin plates or presses. Includes 32 different projects for making stunning layered prints on various materials. Suzanne McNeill. Paperback. 88 pages. 9" x 7".

NUMBER	EACH
A70757-1002	\$13.43



Modern Printmaking

Explore the techniques and history of contemporary printmaking. Illustrated, step-by-step instructions walk readers through a variety of methods. The colorful, in-depth resource also includes inspirational works from 31 of today's top printmaking artists. Sylvie Covey. Hardcover. 320 pages. 8" x 10".

NUMBER	EACH
A70758-1001	\$36.74



Block Print

Everything You Need to Know for Printing with Lino Blocks, Rubber Blocks, Foam Sheets, and Stamp Sets

Make your mark! This hands-on book takes you through step-by-step instructions for creating colorful, classic block print patterns. Projects are great for both experienced artists and first-time printers. Use your prints to customize DIY greeting cards, wallpaper, book illustrations, and more. Andrea Lauren. Flexibound. 144 Pages. 8-1/2" x 10".

NUMBER	EACH
A70761-1001	\$24.40



Magical Secrets About Aquatint

Artists use aquatint, a form of etching, to create delicate washes, velvety blacks, and intricate layers of color impossible in other art media. In this indispensable book and the accompanying DVD, master printer Emily York explores a variety of aquatint processes, including sugar lift and water bite. Emily York. Hardcover with DVD. 360 pages. 10" x 8".

NUMBER	DESCRIPTION	EACH
A68446-1001	Magical Secrets About Aquatint	\$62.99



Gelli Plate Printing

Mixed-Media Monoprinting Without a Press
The revolutionary printing plate that enables a faster, friendlier approach to printmaking now has its own guidebook! It contains more than 50 projects that will have beginners making amazing prints in no time and will push experienced printmakers to experiment, adapt, combine, and layer. Joan Bess. Paperback. 144 pages. 6" x 8-1/4".

NUMBER	EACH
A70752-1001	\$26.24

BLICK® block printing essentials



readycut

Blick® Readycut

Blick proudly presents an innovative new idea in relief printmaking. Blick Readycut is an exclusive product developed to take the guesswork out of relief printing. Created by fusing a thin layer of a traditional gray carving block to a thicker white block, Blick Readycut allows artists to simply carve away the gray layer to reveal the white, and instantly see how their image will look printed. Trace an image on the block — or carve directly for spontaneous creativity. Blick Readycut eliminates repetitive inking, proofing, and cleaning because adjustments and additions are easy to see. Blick Readycut has an infinite shelf life and is soft enough for students at all levels to work with.



Available in a variety of sizes, the plates measure 3/16" (5 mm) thick.

NUMBER	SIZE	EACH	6/EA	12/EA
A40422-0034	3" x 4"	\$3.31	\$2.98	\$2.83
A40422-0045	4" x 5"	4.15	3.74	3.55
A40422-0046	4" x 6"	4.55	4.09	3.88
A40422-0066	6" x 6"	5.57	5.03	4.74
A40422-0068	6" x 8"	6.68	5.99	5.71
A40422-0069	6" x 9"	7.27	6.55	6.21
A40422-0810	8" x 10"	9.79	8.81	8.37
A40422-0912	9" x 12"	12.77	11.49	10.91
A40422-1212	12" x 12"	15.03	13.53	12.85
A40422-1218	12" x 18"	23.62	21.25	20.19

wonder-cut

Blick® Wonder-Cut Linoleum in Pre-Cut Pieces

An ideal surface for students and teachers to practice on, Blick Wonder-Cut Linoleum offers softness and consistency with no slippage. It's easier to cut than our softer Golden-Cut, yet holds sharp lines with no crumbles, for clear, sharp prints. Pencil-drawn cut lines are easily visible on its light color — and a slower hardening process offers the longest shelf life of any Blick linoleum. Natural jute unmounted backing, 1/4" thick.

NUMBER	SIZE	PKG	EACH	12/EA	24/EA
A40417-1029	2" x 3"	12	\$4.08	\$3.67	\$3.48
A40417-1011	3" x 4"	12	5.48	4.93	4.68
A40417-1031	3" x 5"	12	6.26	5.63	5.35
A40417-1051	4" x 5"	12	7.97	7.17	6.81
A40417-1071	4" x 6"	12	8.92	8.03	7.63
A40417-1010	5" x 7"	12	13.47	12.13	11.52
A40417-1091	6" x 8"	12	18.65	16.78	15.94
A40417-1112	8" x 10"	12	28.37	25.53	24.26
A40417-1003	9" x 12"	6	18.63	16.77	15.93
A40417-1124	12" x 12"	1	4.69	4.23	3.99
A40417-1004	12" x 12"	6	23.09	20.79	19.75
A40417-1006	12" x 18"	6	34.55	31.10	29.55
A40417-1018	18" x 18"	1	10.22	9.19	8.73
A40417-1009	18" x 24"	3	37.09	33.38	31.71
A40417-1002	24" x 24"	3	47.67	42.90	40.75
A40417-1005	24" x 36"	3	70.47	63.42	60.25
A40417-1026	36" x 36"	3	104.67	94.20	89.49

Blick® Wonder-Cut Linoleum in Rolls

Does not qualify for free shipping offer. See shipping charge exceptions on page 648 for details.

NUMBER	SIZE	EACH
A40417-1025	12" x 25 ft	\$119.35
A40417-1045	12" x 45 ft	211.35

for all your block printing needs battleship gray

Specially formulated for Blick, we import it from Europe several times a year to provide the softest quality possible. It gives a finely detailed, sharp, clear print. For best results, be sure your blades are sharp! Dull blades are dangerous and frustrating, especially to students. Because of the natural aging process, linoleum should be used within a year of its purchase to take advantage of its peak softness. For your convenience, we offer our 1/8" thick linoleum in pre-cut pieces, by the roll, and mounted on blocks.



Artwork by Tina Browder

A Blick® Unmounted Battleship Gray Linoleum in Pre-Cut Pieces

For your convenience, we offer our unmounted linoleum in packages of pre-cut pieces in popular sizes.

NUMBER	SIZE	PKG	EACH	12/EA
A40404-1029	2" x 3"	48	\$14.19	\$12.77
A40404-1011	3" x 4"	36	18.17	16.34
A40404-1031	3" x 5"	36	21.10	18.98
A40404-1051	4" x 5"	36	26.73	24.04
A40404-1071	4" x 6"	12	12.08	10.87
A40404-1010	5" x 7"	12	16.17	14.55
A40404-1091	6" x 8"	12	20.83	18.73
A40404-1112	8" x 10"	12	35.60	32.04
A40404-1003	9" x 12"	6	22.47	20.21
A40404-1124	12" x 12"	1	3.99	3.59
A40404-1004	12" x 12"	6	29.94	26.92
A40404-1006	12" x 18"	6	47.73	42.98
A40404-1018	18" x 18"	1	11.33	10.19
A40404-1009	18" x 24"	3	47.25	42.55
A40404-1002	24" x 24"	3	61.42	55.31
A40404-1005	24" x 36"	3	89.99	81.03
A40404-1026	36" x 36"	3	132.70	119.43

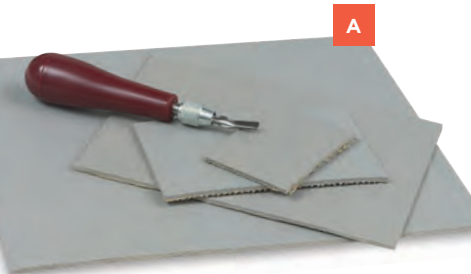

B Blick® Unmounted Battleship Gray Linoleum in Rolls

Enjoy extra savings on the same Battleship Gray Linoleum when you buy in rolls and cut it yourself. Use a sharp knife or paper trimmer. Truck Shipment. See page 648 for details.

NUMBER	SIZE	EACH
A40404-1022	12" x 90 ft	\$351.00
A40404-1024	24" x 90 ft	653.00
A40404-1036	36" x 90 ft	965.00

Shorter Rolls — Does not qualify for free shipping offer.

NUMBER	SIZE	EACH
A40404-1008	12" x 25 ft	\$107.17
A40404-1012	12" x 45 ft	194.83



C Blick® Mounted Battleship Gray Linoleum Blocks

We've mounted our fine-quality Battleship Gray Linoleum on 3/4" thick, pressed wood blocks for easier handling. Total thickness is 7/8".

NUMBER	SIZE	EACH	12/EA
A40404-1000	2" x 2"	\$0.84	\$7.75
A40404-1001	2" x 3"	.95	.85
A40404-1021	3" x 4"	1.77	1.59
A40404-1041	3" x 5"	1.87	1.68
A40404-1061	4" x 5"	2.15	1.93
A40404-1081	4" x 6"	2.27	2.04
A40404-1020	5" x 7"	3.13	2.82
A40404-1101	6" x 8"	4.17	3.75
A40404-1122	8" x 10"	6.45	5.81
A40404-1013	9" x 12"	8.91	7.99
A40404-1014	12" x 12"	10.80	9.68
A40404-1016	12" x 18"	15.58	13.98
A40404-1019	18" x 24"	27.82	24.95
A40404-1015	24" x 36"	61.18	54.86

golden-cut

D Blick® Golden-Cut Unmounted Linoleum in Pre-Cut Pieces

For your convenience, we offer unmounted Golden-Cut Linoleum in packages of pre-cut pieces in popular sizes.

NUMBER	SIZE	PKG	EACH	3/EA	6/EA
A40413-1000	2" x 3"	12	\$6.43	\$5.79	\$5.50
A40413-1001	3" x 4"	12	7.75	6.98	6.59
A40413-1002	3" x 5"	12	8.95	8.05	7.60
A40413-1003	4" x 5"	12	11.28	10.16	9.59
A40413-1004	4" x 6"	12	13.96	12.56	11.86
A40413-1005	5" x 7"	12	17.75	15.98	15.09
A40413-1006	6" x 8"	12	24.48	22.04	20.81
A40413-1008	8" x 10"	12	36.91	33.22	31.37
A40413-1009	9" x 12"	6	24.66	22.20	20.96
A40413-1010	12" x 12"	1	5.43	4.89	4.61
A40413-1011	12" x 12"	6	31.75	28.58	26.99
A40413-1012	12" x 18"	6	46.50	41.85	39.52
A40413-1018	18" x 18"	1	11.28	10.16	9.59
A40413-1013	18" x 24"	3	48.79	43.91	41.71
A40413-1014	24" x 24"	3	59.34	53.41	50.43
A40413-1015	24" x 36"	3	87.17	78.46	74.08
A40413-1016	36" x 36"	3	128.29	115.47	109.03

The fine-textured surface produces sharp, clear prints and won't distort when subjected to high pressure in the printmaking press. And the lighter golden color makes pencil marks easily visible — no need to paint the surface white. Finally, the inevitable hardening-with-age process has been significantly reduced with Blick Golden-Cut Linoleum.

E Blick® Golden-Cut Linoleum in Rolls

Enjoy extra savings on Golden-Cut Linoleum in rolls. Cut it yourself using a sharp knife or paper trimmer. Truck Shipment. See page 648 for details.

NUMBER	SIZE	EACH
A40413-1019	12" x 90 ft	\$271.34

Shorter Rolls — Does not qualify for free shipping offer.

NUMBER	SIZE	EACH
A40413-1022	12" x 25 ft	\$119.93
A40413-1023	12" x 45 ft	211.34

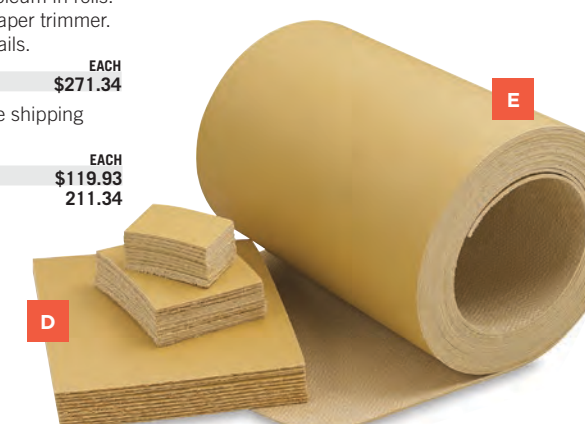

BLICK® block printing comparison chart

Item	Thickness	Backing	Cut	Print Quality	Attributes
Blick Readycut	3/16"	Unmounted, Fused Layer	Soft	Very Good	Gray layer helps to visualize the printed results.
Blick Easy-to-Cut	1/8"	2-Sided	Very Soft	Very Good	Excellent storage, easy to cut, and no crumble.
Blick E-Z-Cut	3/8"	2-Sided	Very Soft	Very Good	Easy to cut, perfect for beginners.
Blick Golden-Cut	1/8"	Unmounted	Medium	Better	Drawing shows clearly. Minimal crumble.
Blick Wonder-Cut	1/4"	Unmounted	Medium	Best	Consistent texture, easy to cut, and no crumble.
Blick Battleship Gray	1/8"	Unmounted or Mounted	Firm	Best	Maintains fine edges when printing.

Inovart® Printfoam for Block Printing

This soft but dense foam material easily takes an impression made by a pencil, stick, or other object. The surface is so sensitive that any shape can be pressed into it for printing textures.

Because it requires only the slightest pressure to create a working impression, it's great for young children — no need for sharp tools. Use waterbased inks and any kind of paper to produce dozens of sharp prints. Cleanup is easy with just running water.

NUMBER	DESCRIPTION	EACH	12/EA	24/EA
A40403-1012	4" x 6", Package of 100	\$11.98	\$10.78	\$10.25
A40403-1022	6" x 9", Package of 30	11.87	10.68	10.15
A40403-1003	9" x 12", Package of 12	6.65	5.99	5.69
A40403-1023	9" x 12", Package of 48	28.70	25.83	24.53
A40403-1006	12" x 18", Package of 12	18.06	16.25	15.45

Class Pack — A special value classroom assortment that includes 100 sheets of 4" x 6", 60 sheets of 6" x 9", 96 sheets of 9" x 12", and 48 sheets of 12" x 18".

NUMBER	EACH	12/EA
A40403-2009	\$143.65	\$129.28

Inovart® Printfoam with Adhesive Back

Same as Printfoam, above, with a self-adhesive backing for easy mounting onto cardboard. Because of the adhesive back, shapes can be cut or torn and stuck down. Excellent for pre-school and primary grades. Each package contains 12, 9" x 12" plates.

NUMBER	EACH	12/EA	24/EA
A40408-0000	\$25.20	\$22.69	\$21.55

Speedball® Speedy-Cut™ Carving Blocks

Great for beginners, printmakers, and stamp carvers, Speedball Speedy-Cut Carving Blocks are soft, high-density rubber blocks that are easy to carve. Use with watersoluble block printing inks only.

NUMBER	SIZE	EACH	12/EA
A40419-1002	2-3/4" x 4-1/2"	\$2.49	\$2.24
A40419-1004	4" x 5-1/2"	4.29	3.86
A40419-1006	6-3/4" x 11"	13.61	12.25

Speedball® Speedy-Carve™ Blocks

A revolutionary pink, eraser-like material that makes carving a breeze! Flexible and durable, Speedy-Carve will not crack, crumble, or break. Use with watersoluble and oil-based block printing inks.

NUMBER	SIZE	EACH	6/EA
A60283-1034	3" x 4"	\$3.46	\$3.11
A40206-9046	4" x 6"	6.99	6.30
A60283-1612	6" x 12"	17.12	15.41
A60283-1009	9" x 11-3/4"	27.72	24.95
A60283-1011	11-3/4" x 11-3/4"	35.58	32.03

Speedball® Speedy-Cut Easy™ Blocks

The super-soft, blue, eraser-like material of Speedy-Cut Easy is even easier to carve than regular Speedy-Cut! This makes it smoother and safer to use, especially for students. Flexible and durable, it will not crack, crumble, or break and is suitable for use with watersoluble block printing inks.

NUMBER	SIZE	EACH	6/EA
A40425-4802	2" x 3"	\$1.66	\$1.50
A40425-4803	3" x 4-1/2"	2.63	2.37
A40425-4804	4" x 6"	4.51	4.06
A40425-4806	6" x 11"	11.33	10.20



Blüm™ Clear Printmaking Blocks

These easy-to-cut blocks are ideal for beginners and advanced printmakers alike. They're made of clear PVC, allowing crisp, clean, accurate cuts. A rubber-like material on the bottom of the block eliminates slippage. Blocks are 1/8" thick.

NUMBER	SIZE	EACH	12/EA
A40452-1003	4" x 6", Pack of 2	\$2.15	\$1.94
A40452-1030	4" x 6", Box of 30	32.18	28.97

Scratch-Foam® Printmaking Class Pack

Kids produce block prints by simply drawing designs with a pencil, ballpoint pen, or stick directly on the foam surface. Very little pressure is needed. Class pack includes 30, 6" x 9" sheets of Scratch-Foam block printing paper in white; 40, 9" x 12" sheets of vibrant SUBI block printing paper; 100, 9" x 12" sheets of SUBI white block printing paper; two rubbing sticks for making clear impressions; six 2-1/2" rubber brayers; three mixing trays; and instructions. Non-toxic.

NUMBER	EACH	12/EA
A42913-1009	\$67.03	\$60.34

MOO Carve Carving Blocks

A revolutionary PVC surface that's latex-free. Its neutral, light gray color is easy to work with, and the thickness allows for deep-carve cutting on one or both sides of the block. It accepts transfer designs, or simply draw directly on it. Won't crumble or break.

NUMBER	SIZE	EACH	12/EA
A40426-1034	3" x 4" x 1/2"	\$5.35	\$4.81
A40426-1044	4" x 4" x 1/2"	6.73	6.05
A40426-1047	4" x 6" x 1/2"	7.99	7.18
A40426-1006	6" x 12" x 1/2"	26.74	24.03
A40426-1067	6-3/4" x 11" x 1/2"	27.99	25.16
A40426-1091	9" x 11-3/4" x 1/2"	36.05	32.39
A40426-1002	2-1/2" x 2-1/2" x 3/4"	3.99	3.62
A40426-1025	2-1/2" x 5" x 3/4"	6.97	6.27
A40426-1046	4" x 6" x 3/4"	11.99	10.79

Richeson® Clear Carve™ Linoleum

Transparent Clear Carve unmounted linoleum can be placed directly over drawings or photos, eliminating the need for image transfer. 1/8" thick.

Sheets		EACH	12/EA
NUMBER	SIZE		
A40427-1034	3" x 4"	\$2.68	\$2.32
A40427-1046	4" x 6"	4.69	4.06
A40427-1057	5" x 7"	5.89	5.10
A40427-1068	6" x 8"	6.70	6.03
A40427-1810	8" x 10"	11.18	10.07
A40427-1212	12" x 12"	17.92	16.14

Rounds		EACH	12/EA
NUMBER	SIZE		
A40427-1004	4"	\$4.96	\$4.49
A40427-1006	6"	7.49	6.78
A40427-1008	8"	9.97	9.03

Richeson® Printmaking Class Pack

Enough supplies for the whole class to get creative! This set includes 24, 4" x 6" easy-to-cut linoleum blocks and 50 sheets of 6" x 9" 135 lb Printmaking Paper. You provide the ink and cutting tools.

NUMBER	EACH
A40450-1009	\$66.09

For more Richeson Easy-to-Cut Linoleum, visit DickBlick.com



Blick® Blue Easy-to-Cut Blocks

An innovative block printing surface that's easy for artists of all ages to carve on. It can be carved on both the front and back side, allowing two images per piece — great savings and less wasted material. Working with traditional lino tools, Easy-to-Cut cuts beautifully whether mounted or unmounted, leaving smooth, clean edges. Works well on curves and tight corners. Its shelf life can be up to 10 times longer than that of traditional linoleum.

NUMBER	SIZE	EACH	12/EA	24/EA
A40420-1045	4" x 5"	\$2.23	\$2.05	\$1.95
A40420-1046	4" x 6"	2.34	2.15	2.05
A40420-1057	5" x 7"	3.03	2.78	2.65
A40420-1066	6" x 6"	3.29	3.03	2.89
A40420-1068	6" x 8"	4.20	3.86	3.68
A40420-1810	8" x 10"	6.31	5.80	5.53
A40420-1912	9" x 12"	8.42	7.74	7.38
A40420-1212	12" x 12"	11.32	10.40	9.92
A40420-1218	12" x 18"	15.44	14.19	13.53

Roll		EACH
NUMBER	SIZE	
A40420-1250	12" x 50 ft	\$593.00

Inovart® Eco Karve Printing Blocks

Made from 100% recycled materials, Eco Karve is a non-toxic, latex-free, environmentally friendly alternative to conventional printing materials. It's smooth and pliable with an unlimited shelf life and a non-slip surface that keeps it from slipping on work surfaces during carving or printing. Easy to carve. Renders sharp, crisp, clean lines. Each plate is 3/8" thick so both sides can be used.

NUMBER	DESCRIPTION	EACH	12/EA
A40424-1046	4" x 6", 2-Pack	\$6.49	\$5.84
A40424-1069	6" x 9", 2-Pack	12.03	10.83
A40424-1023	9" x 12", Single	12.10	10.89
A40424-1006	12" x 18", Single	22.45	20.20



Soft-Kut® Printing Blocks

This rubber material won't skid away from students and doesn't need a bench hook to hold it down. It cuts without requiring much pressure or force. Block thickness is approximately 1/4" — thick enough to allow both sides to be cut, so you get two printing surfaces per block. Cut blocks into small pieces with scissors, a knife, or a paper trimmer for rubber stamping.

NUMBER	SIZE	EACH	12/EA	24/EA
A40401-1001	4" x 6"	\$2.17	\$1.95	\$1.85
A40401-1002	6" x 12"	5.95	5.36	5.09
A40401-1003	9" x 12"	7.84	7.05	6.70
A40401-1004	12" x 12"	10.43	9.39	8.92
A40401-1006	12" x 18"	13.21	11.89	11.30

Soft-Kut® Classroom Starter Kit

Includes 24, 4" x 6" Soft-Kut Printing Blocks, 24 cutter handles, 24 assorted lino cutters, and a 1 lb (16 oz) jar of black waterbased block printing ink. You provide paper and a brayer.

NUMBER	EACH
A40401-1009	\$134.64



Blick® Blue Easy-to-Cut Class Pack

Everything a class of 24 students needs for printmaking, including Easy-to-Cut blocks, cutters, brayers, drawing paper, and two 5 oz (150 ml) tubes of Blick Water-Soluble Block Printing Ink. For full contents, visit DickBlick.com.

NUMBER	EACH
A40421-1009	\$223.70

Blick® E-Z Cut Classroom Starter Kit

All the supplies a class of 24–30 students needs for a printmaking project, including E-Z Cut Printing Blocks, two 2.5 oz (74 ml) tubes of Blick Black Water-Soluble Ink, cutters, brayers, 300 sheets of paper, and instructions. Brayers and cutters can be reused year after year. For full contents, visit DickBlick.com.

NUMBER	EACH
A40409-1001	\$206.69

Blick® E-Z Cut Printing Blocks

The original soft printmaking material!

These blocks of synthetic rubber-like material are so easy to carve that even young students can safely do it. E-Z Cut is 3/8" thick — thick enough that both sides can be carved if desired. It won't slip and slide on the table. It works great with Blick Water-Soluble Inks (see page 375). Two blocks per pack.

NUMBER	SIZE	EACH	12/EA	24/EA
A40402-1001	4" x 5-5/8"	\$6.51	\$5.86	\$5.57
A40402-1003	9" x 11-1/2"	23.97	21.57	20.51





Wood Blocks

These 1/4" thick laminated (plywood) blocks — either Philippine mahogany or white wood — are ideal for woodcut printing, carved plaques, or woodburning. Each package contains 12 pieces.

NUMBER	DESCRIPTION	SIZE	EACH	6/EA
A42902-1001	Mahogany	6" x 8"	\$12.12	\$10.90
A42902-1003	Mahogany	8" x 12"	17.57	15.80
A42902-1006	Mahogany	12" x 16"	28.78	25.89
A42902-1011	White	6" x 8"	16.49	14.83
A42902-1002	White	8" x 12"	26.97	24.26
A42902-1016	White	12" x 16"	51.30	46.13



American Easel Soft Maple Blocks

Softer only as compared to hard maple, these soft maple blocks are a good substitute when a hardwood of moderate density is called for. Soft maple is slightly easier to work with and won't dull cutting edges as quickly. The 5/16" thick blocks can be carved on both sides.

NUMBER	SIZE	EACH	6/EA
A40453-1057	5" x 7"	\$11.13	\$9.99
A40453-1068	6" x 8"	15.37	13.81
A40453-1810	8" x 10"	20.40	18.33
A40453-1912	9" x 12"	26.76	24.05



American Easel Wood Printing Blocks

Made from high-quality 1/4" Baltic Birch plywood, these wood printing blocks are sanded smooth and ready to use. Baltic Birch is free of voids and knots. The blocks have two usable sides. Packs of 12. Made in the USA.

NUMBER	SIZE	EACH	12/EA
A40442-1121	6" x 8"	\$29.93	\$26.94
A40442-1812	8" x 12"	47.94	43.15



RGM® Exclusive Linoleum Knives

These Italian-made linoleum knives feature tempered steel blades set in shock-resistant fiberglass handles. Blades are thermally attached to handles and reinforced with a brass containment ferrule. These are solidly constructed linoleum carving tools at an economical price.

NUMBER	DESCRIPTION	EACH	6/EA
A40202-0301	301	\$7.41	\$6.67
A40202-0302	302	7.41	6.67
A40202-0303	303	7.41	6.67
A40202-0304	304	7.41	6.67
A40202-0305	305	7.41	6.67
A40202-0306	306	7.41	6.67
A40202-0307	307	7.41	6.67
A40202-0308	308	7.41	6.67
A40202-0309	309	7.41	6.67
A40202-0310	310	7.41	6.67
A40202-0311	311	7.41	6.67
A40202-0312	312	7.41	6.67

Set of 5 Tools with Sharpening Stone — Tools 301, 304, 306, 308, and 309.

NUMBER	EACH	6/EA
A40202-1009	\$33.81	\$30.44



Speedball® Baren

Use this baren for hand printing. Its base is almost friction-free. Long-wearing. 4-1/2" diameter.

NUMBER	EACH	3/EA
A42905-1045	\$25.94	\$24.18



Blick® Economy Baren

Tough, impact-proof, smooth ABS plastic surface, with easy-to-grip wood handle. Glides easily over printed paper and is perfect for any hand size. 3-3/4" diameter. Great for block printing and other burnishing/printing applications.

NUMBER	EACH	12/EA
A42910-1004	\$12.99	\$11.71

- 301
- 302
- 303
- 304
- 305
- 306
- 307
- 308
- 309
- 310
- 311
- 312



Esdee™ Three-in-One Lino Cutting Baren Kit

An ideal tool for use in lino printing and block making, this versatile kit can be used as a lino cutter with the included handle and five cutters, as a baren for burnishing, as a stamper using the SoftCut™ discs, and as a storage unit for the cutter blades. Manufacturer's Note: This product is not a toy.

NUMBER	DESCRIPTION	EACH	6/EA
A40208-1001	Kit	\$11.65	\$10.49
A40208-2010	Discs, 10-Pack	6.29	5.66



Small Wooden Linoleum Cutter

Made of lightweight wood in a size that's perfect for smaller hands. Tiny wooden peg keeps the blades intact, so they're easy to install and change. Handle only, or set with handle and cutter numbers 1, 2, 5, 8, 9, and 10.

NUMBER	DESCRIPTION	EACH	12/EA
A40207-1001	Handle Only	\$3.40	\$3.06
A40207-1069	Handle w/ 6 Cutters	8.40	7.56

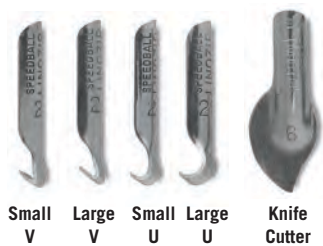

Small V Large V Small U Large U Knife Cutter

Speedball® Linozips

These safe "pull-type" cutters are made of fine-quality steel with a sharp cutting edge. For use with Speedball handle only.

NUMBER	DESCRIPTION	EACH	12/EA
A40204-1021	#21 Small V	\$1.66	\$1.50
A40204-1022	#22 Large V	1.66	1.50
A40204-1023	#23 Small U	1.66	1.50
A40204-1025	#25 Large U	1.66	1.50

Speedball Linozip Set — Set has a handle and 4 Linozips, styles #21 Small V, #22 Large V, #23 Small U, and #25 Large U. Also includes Speedball style 6 knife cutter.

NUMBER	EACH	12/EA
A40204-1009	\$11.54	\$10.39



Inovart® Quick Release Cutter

Inovart's unique "Quick Release" system allows artists to quickly and easily change blades by simply pulling up on the chuck of the handle. The yellow portion of the handle is removable, revealing a compartment inside that can store up to five blades. Set includes small and large V-shaped and U-shaped gouges made of long-lasting carbon steel.

NUMBER	DESCRIPTION	EACH	12/EA
A40221-1002	Handle w/2 Blades	\$13.25	\$11.92
A40221-1005	Handle w/5 Blades	16.38	14.75
A40221-1001	Handle Only	7.20	6.48



Blick® Lino Cutter Set

Six stainless steel blades (two V-shaped cutters, two U-shaped gouges, a liner cutter, and a knife) are contained in a balanced handle with a twist-off cap. Clutch mechanism assures easy blade changing.

NUMBER	EACH	6/EA
A40216-1001	\$12.18	\$10.96



Esdee™ Small Plastic Linoleum Cutter

Get a grip on a linoleum cutter and achieve stellar results at an economical price. Fit for smaller hands, the sturdy, molded plastic handle has a screw chuck and finest-quality ground steel blades. 2-1/2" long.

NUMBER	DESCRIPTION	EACH	12/EA
A40208-1005	Handle w/5 Cutters	\$13.56	\$12.20
A40208-1010	Handle w/10 Cutters	17.69	15.92
A40208-2515	25 Cutters, Sizes 1-5	29.50	26.55
A40208-2510	25 Cutters, Sizes 1-10	29.50	26.55
A40208-1012	12 Handles	43.15	38.84



Speedball® Linoleum Cutter Handles

Combining comfort, control, and convenience, these hard plastic handles feature a removable end for storing cutters. The adjustable metal chuck makes it easy to install and remove cutters.

NUMBER	COLOR	EACH	12/EA
A40201-4860	Blue	\$4.35	\$3.73
A40201-0000	Burgundy	4.35	3.73
A40201-7030	Green	4.35	3.73
A40211-1001	Red	4.51	4.06
A40201-4020	Yellow	4.35	3.73



Small V Large V Small U Square Large U Knife

Speedball® Linoleum Cutters

Improved Design! Made from the finest-quality steel with long-lasting cutting edges, honed on the inside for better control. Use with Speedball Cutter Handles (bottom row). Note: For best results, we recommend honing cutters before use. Available in packs of two and boxes of 12. (May not be assorted.)

Pack of 2 Cutters

NUMBER	DESCRIPTION	EACH	12/EA
A40203-1202	#1 Small V	\$3.41	\$2.90
A40203-1402	#2 Large V	3.41	2.90
A40203-1302	#3 Small U	3.41	2.90
A40203-0100	#4 Square	3.41	2.90
A40203-1002	#5 Large U	3.41	2.90
A40203-1102	#6 Knife	3.41	2.90

Box of 12 Cutters

NUMBER	DESCRIPTION	EACH	12/EA
A40203-1212	#1 Small V	\$16.72	\$14.99
A40203-1412	#2 Large V	16.72	14.99
A40203-1312	#3 Small U	16.72	14.99
A40203-0000	#4 Square	16.72	14.99
A40203-1012	#5 Large U	16.72	14.99
A40203-1112	#6 Knife	16.72	14.99



Speedball® Lino Set No. 1

This set contains a handle with five cutters: #1 Small V, #2 Large V, #3 Small U, #5 Large U, and Knife. The end of the handle is removable for storage of cutters.

NUMBER	EACH	12/EA
A40203-1009	\$11.39	\$10.75

Set of 5 Cutters without Handle — #1 Small V, #2 Large V, #3 Small U, #5 Large U, and Knife.

NUMBER	EACH	12/EA
A40203-1019	\$8.29	\$7.55

Speedball® Lino Set No. 2

This set includes six Speedball linoleum cutters: #1 Small V, #2 Large V, #3 Small U, #4 Square, #5 Large U, Knife, and two Speedball handles. The end of the handles is removable for storing the cutters.

NUMBER	EACH	12/EA
A40203-1029	\$15.58	\$13.97



Inovart® Pro-Roller Brayers

Professional brayers feature an ergonomic, soft-grip handle with finger grips. Lightweight and durable all-aluminum carriage doubles as a stand for the roller — does not allow roller to rest on any surface. This eliminates mess. Roller is made of soft, latex-free material; durable Delrin® plastic roller system.

NUMBER	SIZE	EACH	6/EA	12/EA
A40122-1004	4"	\$16.85	\$15.17	\$14.40
A40122-1006	6"	21.30	19.17	18.21



Speedball® Hard Rubber Brayer

One-piece plastic construction with one 4" wide black hard rubber roller. Core unit will not shrink or swell when immersed.

NUMBER	SIZE	EACH	6/EA
A40105-1004	4"	\$9.53	\$8.83



Essdee™ Deluxe Artists' Soft Rubber Brayers

This pro-grade brayer features a fully concentric, machine-ground rolling surface for smooth and fine ink application. Made of medium-hard EPDM rubber, the heavyweight roller gives excellent pickup and deposit of all types of ink. It's strong and durable, with a heat-treated steel frame, self-lubricating nylon bearings, and an ergonomically designed handle with a hanging slot for easy drying and storage.

NUMBER	SIZE	EACH	6/EA
A40111-1003	3"	\$33.50	\$30.15
A40111-1004	4"	36.48	32.83
A40111-1008	8"	58.14	52.33

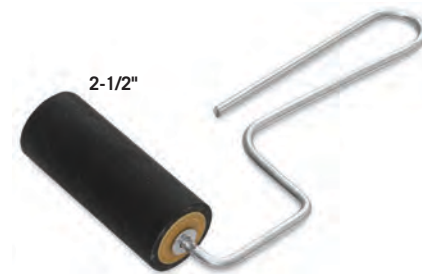

Scratch-Art® Hard Rubber Brayer

Constructed with a sturdy wire frame and a hard rubber roller, this brayer is a great, economical value. Each roller is 2-1/2" wide and the handle is 3-1/2" long.

NUMBER	DESCRIPTION	EACH	24/EA
A40113-1010	Hard	\$5.63	\$5.07



Educational Hard Polypropylene Brayers

Ideal for classroom projects, these strong, durable brayers have heat-treated steel frames and self-lubricating nylon bearings. Their polypropylene handles are ergonomically designed with a molded pressure point and stand. A handy slot makes it easy to hang the brayers for drying or storage.

NUMBER	SIZE	EACH	6/EA
A40100-1002	2"	\$13.82	\$12.44
A40100-1025	2-1/2"	14.82	13.34
A40100-1003	3"	15.82	14.24
A40100-1004	4"	16.78	15.10
A40100-1006	6"	20.78	18.70
A40100-1008	8"	24.73	22.25



Speedball® Soft Rubber Brayers

The soft, smooth 1-3/16" diameter rollers on these brayers are made from natural latex gum rubber with a precision-ground finish. They're mounted on a durable, heavy-duty steel frame and attached to sturdy plastic handles. The 40/42 durometer ensures even ink distribution. Ideal for use with linoleum, soft block, or woodcut, and watersoluble or oil-based inks.

NUMBER	SIZE	EACH	6/EA
A40104-1015	1-1/2"	\$11.85	\$10.67
A40104-1002	2"	12.50	11.25
A40104-1025	2-1/2"	13.25	11.93
A40104-1003	3"	15.50	13.95
A40104-1035	3-1/2"	15.99	14.24
A40104-1004	4"	16.99	15.29
A40104-1006	6"	18.92	17.03



Speedball® Pop-In™ Brayer Kit

A convenient 4-pack of interchangeable 4" brayer rollers. Each set includes a soft rubber brayer, hard rubber brayer, acrylic brayer, and a foam roller. See below for replacement rollers.

NUMBER	EACH	6/EA
A40112-1009	\$37.70	\$33.94

Replacement Rollers

NUMBER	DESCRIPTION	EACH	6/EA
A40112-0002	Hard	\$7.84	\$7.06
A40112-0004	Acrylic	11.60	10.44
A40112-0003	Foam	7.73	6.96



Testrite® Hard Rubber Brayers

Use these all-purpose rubber brayers to apply ink and to roll down prints. They feature a one-piece, plated metal handle.

NUMBER	SIZE	EACH	6/EA
A40101-1004	4"	\$9.97	\$9.23
A40101-1006	6"	11.80	10.92
A40101-1008	8"	13.62	12.60



Richeson® Metal Inking Plates

Made of sturdy, easy-to-clean metal, these inking plates have a lip that fits securely over the edge of your work surface and a stop that stabilizes your linoleum blocks during carving or inking.

NUMBER	SIZE	EACH	6/EA
A36938-0710	7-1/2" x 10-1/4"	\$14.79	\$13.31
A36938-1214	12-1/2" x 14-1/2"	22.38	20.14

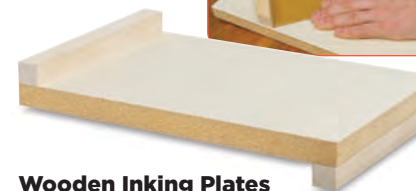

Wooden Inking Plates

Great for rolling ink out in preparation for inking up a plate or block. Also works well as a stop; place the linoleum or wood block against the lip. Plate is 3/4" off-white melamine on pine, stapled and glued (7-1/2"W x 11-1/4"D). V-Groove plate measures 7-1/2"W x 14"D.

NUMBER	DESCRIPTION	EACH	6/EA
A42906-1002	Plate	\$6.89	\$6.29
A42906-1003	V-Groove Plate	9.91	9.06



Inovart® Soft Rubber Brayers

Economical, long-lasting soft rubber brayer is made of latex-free material. The brayer core snaps out for quick and easy cleanup or replacement.

NUMBER	SIZE	EACH	6/EA	12/EA
A40121-1004	4"	\$11.23	\$10.10	\$9.60
A40121-1006	6"	13.05	11.75	11.15



Testrite® Foam Brayers

Soft but dense foam brayer is ideal for stencils, printmaking, cut-outs, and all printing techniques using waterbased paints. Plated steel handle, solid wood core under heavy foam for smooth rolling. Handle opens for washing or replacement of foam.

NUMBER	SIZE	EACH	10/EA
A40102-1004	4"	\$9.98	\$8.97
A40102-1006	6"	11.80	10.62
A40102-1008	8"	13.62	12.26

Replacement Foam — One roller in each package.

NUMBER	SIZE	EACH	10/EA
A40102-1104	4"	\$6.60	\$5.94
A40102-1106	6"	7.52	6.77
A40102-1108	8"	8.88	7.99



Speedball® Hard Rubber Brayers

A hard synthetic rubber roller (80 durometer) makes these brayers ideal for light carving or gluing applications, and excellent for rolling down print surfaces. Available with either a heavy-duty steel frame or a wire frame. Both are 4" wide, feature a durable plastic comfort-grip handle, and come with a free craft tip usage guide.

NUMBER	DESCRIPTION	EACH	6/EA
A40118-1004	Heavy-Duty Steel Frame	\$15.07	\$13.57
A40125-1004	Wire Frame	15.37	13.83
A40105-1004		9.53	8.83



A-B Speedball® Hard Rubber Brayers

A hard synthetic rubber roller (80 durometer) makes these brayers ideal for light carving or gluing applications, and excellent for rolling down print surfaces. Available with either a heavy-duty steel frame or a wire frame. Both are 4" wide, feature a durable plastic comfort-grip handle, and come with a free craft tip usage guide.

NUMBER	DESCRIPTION	EACH	6/EA
A40118-1004 A	Heavy-Duty Steel Frame	\$15.07	\$13.57
A40125-1004 B	Wire Frame	15.37	13.83

Martin™ Universal Carving Block Holder

Safely carve linoleum or MOO Carving Blocks with Martin's natural wood carving block holder. Ideal for novices or professionals, the block holder has an angled inset that allows for left-handed or right-handed use, and a lip that fits snugly against the edge of a tabletop for stability while cutting. The holder measures 8-3/4"W x 12"D and accommodates a variety of block sizes.

NUMBER	EACH	6/EA
A38017-1012	\$30.22	\$27.21



Speedball® Metal Inking Plate/Bench Hook

This unbreakable, all-metal inking plate features a lip designed to fit over desk or table edges. Its powder-coated surface makes it easy to clean. Can also be used as a bench hook. 7-3/8"W x 9-3/8"D.

NUMBER	EACH	6/EA
A42911-1000	\$15.19	\$13.67



Amaco® Paragona™ Glass Artist Palettes

Intended to rest on a table rather than be held, these palettes are excellent for mixing large volumes of paint, rolling printing ink, and even for monoprinting and clay crafts. Made of tempered safety glass with comfortable, beveled edges and a white vinyl backing, they're perfectly smooth, non-porous, and easy to clean. Both shapes measure 11" x 14".

NUMBER	DESCRIPTION	EACH	6/EA
A03034-1915	Rectangular	\$36.95	\$33.25
A03034-1905	Oval	46.54	41.89



Inking Plate/Bench Hook

Place one lip of this sturdy metal plate over the edge of your desk or table. Use it to roll ink out in preparation for inking up a plate or block, or place a linoleum or wood block on the plate against the other lip to act as a stop when carving. 7-1/4"W x 8-1/2"D.

NUMBER	EACH	6/EA
A42904-0000	\$11.18	\$10.06

CRANFIELD



Cranfield Caligo Safe Wash Relief Inks

These oil-based relief inks feel and work like traditional oil-based inks, yet clean up with soap and water — no solvents required! Made from the finest single pigments and polymerized vegetable oil, they're suitable for all kinds of block printing, including wood engraving, linocut, woodcut, and letterpress printing with photopolymer plates. These colors stay bright and clean when mixed. They're made without driers, dry like traditional etching inks, and can be printed on a wide range of papers with the quality, intensity, and precision of an oil-based ink.

COLOR	2.5 OZ (75 ML) TUBE	EACH	5 OZ (150 ML) TUBE	EACH	8.8 OZ (250 G) JAR	EACH	17.6 OZ (500 G) JAR	EACH
Arylide Yellow	A40320-4913	\$16.92	A40320-4914	\$23.47	A40320-4912	\$23.99	A40320-4915	\$48.04
Black	A40320-2023	15.28	A40320-2024	22.72	A40320-2022	24.59	A40320-2025	43.43
Burnt Sienna	A40320-8043	17.99	A40320-8044	25.39	A40320-8042	26.17	A40320-8045	48.04
Carbazole Violet	A40320-6553	21.83	A40320-6554	36.03	A40320-6552	40.35	A40320-6555	75.33
Diarylide Yellow	A40320-4493	16.92	A40320-4494	25.32	A40320-4492	29.75	A40320-4495	51.13
Light Orange	A40320-4513	16.92	A40320-4514	25.32	A40320-4512	26.57	A40320-4515	51.27
Naphthol Red	A40320-3603	17.99	A40320-3604	25.11	A40320-3602	29.44	A40320-3605	50.22
Opaque White	A40320-1083	15.28	A40320-1084	22.38	A40320-1082	23.99	A40320-1085	42.58
Phthalo Blue	A40320-5163	16.92	A40320-5164	25.11	A40320-5162	26.17	A40320-5165	48.04
Phthalo Green	A40320-7803	17.99	A40320-7804	29.48	A40320-7802	29.44	A40320-7805	58.41
Process Blue	A40320-5513	15.28	A40320-5514	23.47	A40320-5512	23.99	A40320-5515	42.58
Process Red	A40320-3713	19.65	A40320-3714	33.30	A40320-3712	37.08	A40320-3715	68.78
Process Yellow	A40320-4403	16.92	A40320-4404	23.47	A40320-4402	23.99	A40320-4405	42.58
Prussian Blue	A40320-5223	15.28	A40320-5224	25.11	A40320-5222	26.17	A40320-5225	48.04
Raw Umber	A40320-8073	15.28	A40320-8074	22.38	A40320-8072	23.99	A40320-8075	42.58
Rubine Red	A40320-3743	16.92	A40320-3744	25.11	A40320-3742	26.17	A40320-3745	48.04
Ultramarine	—	—	—	—	A40320-5232	26.37	A40320-5235	48.99
Yellow Ochre	A40320-4043	16.92	A40320-4044	22.38	A40320-4042	26.17	A40320-4045	48.04



Speedball Professional Relief Ink

This new line of artist-quality, water-miscible, oil-based printmaking inks was developed using only the highest-quality, lightfast pigments and no fillers. The results are rich, intense, crisp prints with archival qualities. Formulated to achieve the working properties artists desire, Speedball Professional Relief Inks roll out consistently, transfer beautifully, and hold even the finest details. And they clean up easily with just soap and water. The flagship of the line is Supergraphic Black, created in collaboration with world-renowned relief artist Bill Fick.

NUMBER	COLOR	EACH
A37335-3715	Crimson Red	\$25.06
A37335-4495	Diarylide Yellow	25.06
A37335-6915	Dioxazine Violet	25.06
A37335-4705	Hansa Yellow Light	21.54
A37335-5165	Phthalo Blue	21.54
A37335-7805	Phthalo Green	21.54
A37335-3275	Quinacridone Red	25.06
A37335-2005	Supergraphic Black	18.82
A37335-1025	Titanium White	18.82
A37335-1005	Transparent Base	18.82
A37335-5235	Ultramarine Blue	21.54

NUMBER	COLOR	EACH
A37335-2026	Supergraphic Black	\$33.99

Set of 4 — Includes 8 oz tins of Supergraphic Black, Quinacridone Red, Hansa Yellow Light, and Phthalo Blue.

NUMBER	EACH
A37335-1049	\$76.31

Set of 6 — Includes 8 oz tins of Supergraphic Black, Quinacridone Red, Hansa Yellow Light, Phthalo Blue, Titanium White, and Transparent Base.

NUMBER	EACH
A37335-1069	\$105.59



Cranfield Caligo Transparent Extender

Use this extender to control the color strength of Cranfield Caligo Safe Wash Relief Inks.

NUMBER	SIZE	EACH
A40320-1003	2.5 oz (76 ml) Tube	\$15.28
A40320-1004	5 oz (150 ml) Tube	22.38
A40320-1002	8.8 oz (250 g) Jar	23.99
A40320-1005	17.6 oz (500 g) Jar	42.58

Cranfield Caligo Wiping Compound

Modify the tack of Cranfield Caligo Safe Wash Inks.

NUMBER	SIZE	EACH
A40319-1094	5 oz (150 ml) Tube	\$21.83
A40319-1095	17.6 oz (500 g) Jar	34.30

Cranfield Caligo Safe Wash Oil

Use this oil to dilute Cranfield Caligo Safe Wash Inks.

NUMBER	SIZE	EACH
A40319-1191	8.45 oz (250 ml) Jar	\$17.54



Speedball Fabric and Paper Block Printing Ink

Experience the beauty of block printing on fabric with an ink that works just as well on fabric as it does on paper. These oil-based inks provide bold, opaque, permanent color that cleans up easily with soap and water. Excellent on cotton, polyester blends, linen, rayon, and other synthetic fibers (except for nylon), as well as paper and cardboard.

Colors can be assorted for quantity pricing.

NUMBER	COLOR	EACH	6/EA
A40326-2024	Black	\$9.61	\$8.65
A40326-5024	Blue	9.61	8.65
A40326-8014	Brown	9.61	8.65
A40326-7004	Green	9.61	8.65
A40326-3314	Magenta	9.61	8.65
A40326-9024	Metallic Gold	9.61	8.65
A40326-2404	Metallic Silver	9.61	8.65
A40326-1084	Opaque White	9.61	8.65
A40326-4504	Orange	9.61	8.65
A40326-3004	Red	9.61	8.65
A40326-5114	Turquoise	9.61	8.65
A40326-6504	Violet	9.61	8.65
A40326-1024	White	9.61	8.65
A40326-4204	Yellow	9.61	8.65

For more sizes, visit DickBlick.com.



Set of 6 — Includes six 1.25 oz (37 ml) tubes of color, including one each of Red, Blue, Yellow, Green, Black, and White.

NUMBER	EACH	6/EA
A40326-1069	\$29.04	\$26.14

BLICK® water-soluble inks

Blick Water-Soluble Block Printing Inks

Our pigments are ground and milled to the perfect consistency to produce optimum results in block printing — good coverage without over-inking. Cleans up easily with water. Colors can be assorted for quantity pricing.

COLOR	2.5 OZ (75 ML) TUBE	5 OZ (147 ML) TUBE	8 OZ (237 ML) JAR	16 OZ (473 ML) JAR
Black	A40305-2004	A40305-2007	A40305-2005	A40305-2006
Blue	A40305-5004	A40305-5007	A40305-5005	A40305-5006
Brown	A40305-8004	A40305-8007	A40305-8005	A40305-8006
Dark Yellow	A40305-4034	A40305-4037	A40305-4035	A40305-4036
Gold	A40305-4054	A40305-4057	A40305-4055	A40305-4056
Green	A40305-7004	A40305-7007	A40305-7005	A40305-7006
Light Red	A40305-3014	A40305-3017	A40305-3015	A40305-3016
Magenta	A40305-3044	A40305-3047	A40305-3045	A40305-3046
Orange	A40305-4504	A40305-4507	A40305-4505	A40305-4506
Red	A40305-3004	A40305-3007	A40305-3005	A40305-3006
Silver	A40305-9304	A40305-9307	A40305-9305	A40305-9306
Turquoise	A40305-5114	A40305-5117	A40305-5115	A40305-5116
Violet	A40305-6504	A40305-6507	A40305-6505	A40305-6506
White	A40305-1004	A40305-1007	A40305-1005	A40305-1006
Yellow	A40305-4004	A40305-4007	A40305-4005	A40305-4006
EACH	\$5.81	EACH \$8.58	EACH \$10.49	EACH \$17.13
	3/EA 5.23	3/EA 7.72	3/EA 9.44	3/EA 15.38
	6/EA 4.91	6/EA 7.41	6/EA 8.97	6/EA 14.64

Extender — Creates subtle transparent colors and maintains ink viscosity. 1.25 oz (37 ml) tube.

NUMBER	EACH	3/EA
A40303-9000	\$4.19	\$4.03

Retarder — Slows drying time for watersoluble inks during printing. 1.25 oz (37 ml) tube.

NUMBER	EACH	3/EA
A40303-0014	\$4.47	\$4.04



A-C Speedball Block Printing Kits

A Starter Set — Contains one each: 1.25 oz (37 ml) tube Black Water-Soluble Block Printing Ink; 4" pop-in soft rubber brayer; Red lino handle; #1, #2, and #5 lino cutters; 4" x 6" Speedy-Carve block; and instructions.

B Ink Starter Set — Six 1.25 oz (37 ml) tubes of Water-Soluble Red, Blue, Yellow, Black, White, and Gold Block Printing Inks. Dries to a rich, satiny finish and cleans up easily with soap and water.

C Deluxe Kit — One each 4" x 5" mounted lino block; 4" x 6" Speedy Stamp; lino handle; #1, #2, #3, #5 cutters; #6 knife; 2.5 oz (75 ml) Black Water-Soluble Block Printing Ink; 1.25 oz (37 ml) Red, Blue, Yellow Water-Soluble block printing ink; 1.25 oz (37 ml) block printing extender; 4" soft pop-in brayer; bench hook/inking plate; and tips and ideas booklet.

NUMBER	EACH	6/EA
A40303-1009	\$28.09	\$25.28

Speedball Water-Soluble Block Printing Ink Extender & Retarder

Extender — Creates subtle transparent colors and maintains ink viscosity. 1.25 oz (37 ml) tube.

NUMBER	EACH	3/EA	6/EA
A40303-9000	\$4.19	\$4.03	\$3.78

Retarder — Slows drying time for watersoluble inks during printing. 1.25 oz (37 ml) tube.

NUMBER	EACH	3/EA	6/EA
A40303-0014	\$4.47	\$4.04	\$3.83



SPEEDBALL® WATER-SOLUBLE INKS

Speedball Water-Soluble Block Printing Inks

Formulated to work equally well for block printing with soft and hard surfaces, including linoleum, wood block, flexible vinyl plate, and polyfoam. Ink cleans up easily with water. Excellent for studio or school use. Colors can be assorted for quantity pricing.

COLOR	1.25 OZ (37 ML) TUBE	2.5 OZ (75 ML) TUBE	5 OZ (147 ML) TUBE	8 OZ (237 ML) JAR	16 OZ (473 ML) JAR
Black	A40303-2003	A40303-2004	A40303-4604	A40303-2005	A40303-2006
Blue	A40303-5003	A40303-5004	A40303-5116	A40303-5005	A40303-5006
Brown	A40303-8003	A40303-8004	A40303-7104	A40303-8005	A40303-8006
Copper	A40303-9803	A40303-9804	A40303-9800	A40303-9805	A40303-9806
Dark Yellow	A40303-4030	A40303-4031	A40303-3144	—	—
Fluorescent Blue	A40303-5243	A40303-5244	A40303-5240	A40303-5245	A40303-5246
Fluorescent Hot Pink	A40303-3293	A40303-3294	A40303-3290	A40303-3295	A40303-3296
Fluorescent Lime Green	A40303-7233	A40303-7234	A40303-7230	A40303-7235	A40303-7236
Fluorescent Magenta	A40303-3053	A40303-3054	A40303-3040	A40303-3055	A40303-3056
Fluorescent Orange	A40303-4563	A40303-4564	A40303-4560	A40303-4565	A40303-4566
Fluorescent Yellow	A40303-4223	A40303-4224	A40303-4220	A40303-4225	A40303-4226
Gold	A40303-4053	A40303-4054	A40303-4154	A40303-4055	A40303-4066
Green	A40303-7003	A40303-7004	A40303-5104	A40303-7005	A40303-7006
Light Red	A40303-3010	A40303-3011	A40303-2104	—	—
Magenta	A40303-3043	A40303-3044	A40303-6604	A40303-3045	A40303-3046
Orange	A40303-4503	A40303-4504	A40303-4104	A40303-4505	A40303-4506
Pewter	A40303-2583	A40303-2584	A40303-2580	A40303-2585	A40303-2586
Platinum	A40303-1023	A40303-1024	A40303-1020	A40303-1025	A40303-1026
Process Cyan	A40303-5513	A40303-5514	A40303-5510	A40303-5515	A40303-5516
Process Magenta	A40303-3713	A40303-3714	A40303-3712	A40303-3715	A40303-3716
Process Yellow	A40303-4403	A40303-4404	A40303-4402	A40303-4405	A40303-4406
Red	A40303-3003	A40303-3004	A40303-9300	A40303-3005	A40303-3006
Silver	A40303-9600	A40303-9600	A40303-9400	A40303-9505	A40303-9706
Turquoise	A40303-5113	A40303-5114	A40303-5214	A40303-5115	A40303-4056
Violet	A40303-6503	A40303-6504	A40303-8104	A40303-6505	A40303-6506
White	A40303-1003	A40303-1004	A40303-3104	A40303-1005	A40303-1006
Yellow	A40303-4003	A40303-4004	A40303-1104	A40303-4005	A40303-4006
EACH	\$4.19	EACH \$6.56	EACH \$9.26	EACH \$12.43	EACH \$19.46
	3/EA 4.03	3/EA 5.89	3/EA 8.33	3/EA 11.20	3/EA 17.50
	6/EA 3.78	6/EA 5.56	6/EA 7.86	6/EA 10.63	6/EA 16.55



Flounder Bluegill



Perch



Walleye



Trout



Bass



Piranha Scallop Shell



Seahorse Turtle Starfish



Grass Frog Bull Frog Gecko Alligator

Make clay impressions for casting!

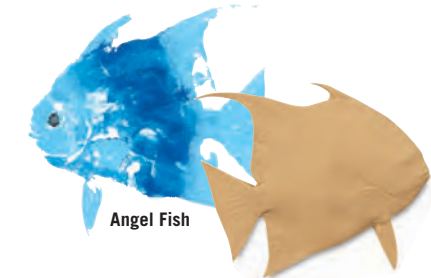

Angel Fish

gyotaku

Learn the Japanese art of fish rubbing.

Enjoy making impressions from these extremely lifelike rubber fish replicas. Cast from real fish and reptiles, these life-size replicas are detailed and dimensional on one side for printing and flat on the other. Sizes range from 4-1/2" (Scallop Shell) to 12" long (Trout). Using tempera or block printing ink, apply colors directly to the rubber form with a foam brayer or soft brush. The results will be different and original each time. Press them into clay to create 3-D impressions.

9-Piece Fish Set — Bluegill, Starfish, Flounder, Piranha, Angel Fish, Trout, Perch, Bass, and small Walleye.

NUMBER	EACH	6/EA
A42907-1009	\$110.23	\$99.22

4-Piece Fish Set — Flounder, Piranha, Angel Fish, and Bass.

NUMBER	EACH	6/EA
A42907-1004	\$56.76	\$51.09

Individual Fish

NUMBER	DESCRIPTION	EACH	6/EA
A42907-1014	Angel Fish	\$17.48	\$16.08
A42907-1002	Bass	17.48	16.08
A42907-1005	Bluegill	15.97	14.38
A42907-1006	Flounder	17.48	16.08
A42907-1001	Perch	15.97	14.38
A42907-1007	Piranha	15.15	13.63
A42907-1016	Scallop Shell	14.17	12.76
A42907-1017	Seahorse	9.36	8.43
A42907-1003	Starfish	13.07	11.76
A42907-1008	Trout	17.48	16.08
A42907-1010	Walleye	15.97	14.38

Individual Reptiles

NUMBER	DESCRIPTION	EACH	6/EA
A42907-1021	Alligator	\$15.15	\$13.63
A42907-1019	Bull Frog	15.15	13.63
A42907-1022	Gecko	14.17	12.76
A42907-1020	Grass Frog	15.15	13.63
A42907-1015	Turtle	18.58	16.73

4-Piece Reptile Set — Bull Frog, Grass Frog, Alligator, and Gecko.

NUMBER	EACH	6/EA
A42907-1018	\$51.25	\$46.13

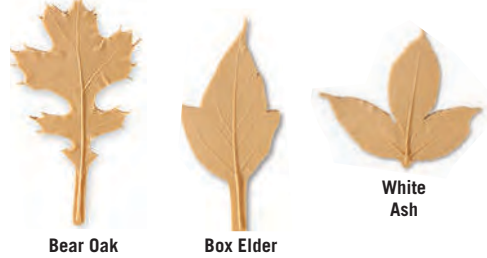

Bear Oak Box Elder



White Ash

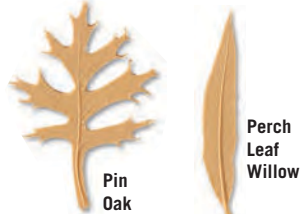

Pin Oak Perch Leaf Willow



Quaking Aspen



Shagbark Hickory Red Mulberry Royal Mt. Ash



Japanese Maple

Leaf Print Set of 10

Cast from actual leaves, these rubber replicas create realistic impressions for countless applications. A great classroom tool for stimulating discussions about biodiversity and nature printing in general.

The set includes one each of the 10 leaves pictured above. Sizes range from 8" to 8-1/2" long.

NUMBER	EACH	6/EA
A42909-1010	\$36.37	\$32.74

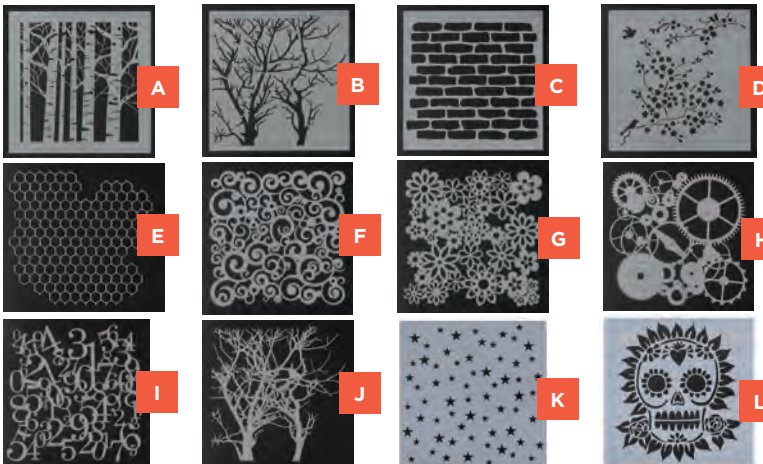

The Crafter's Workshop® Stencils

Use these durable, reusable stencils to add accents on monoprints and gel plates, collages, fabric, and paper. Made from easy-to-clean, semi-translucent plastic, they work well with paints, gesso, inks, dimensional pastes, sprays, and pens. 6" x 6".

NUMBER	DESCRIPTION	EACH	6/EA
A38152-1003	A Aspen Trees	\$6.60	\$5.94
A38152-1803	B Branches	6.60	5.94
A38152-1503	C Bricks	6.60	5.94
A38152-1303	D Cherry Blossoms	6.60	5.94
A38152-1603	E Chicken Wire	6.60	5.94
A38152-1103	F Cosmic Swirl	6.60	5.94
A38152-1203	G Gathered Flowers	6.60	5.94
A38152-1703	H Gears	6.60	5.94
A38152-1903	I Numbers Collage	6.60	5.94
A38152-1403	J Reversed Branches	6.60	5.94
A38152-2003	K Random Stars	6.60	5.94
A38152-2103	L Sugar Skull	6.60	5.94

Grafix® Impress™ Monoprint Plate Packs

Transparent, durable, flexible, and non-porous. Use these plates to create unique prints by applying paint, using stencils, tracing, or removing ink.

Very economical when compared to metal or glass plates, they're also lightweight, easy to transport, and easy to clean. Drypoint and collage techniques are also possible with these multipurpose plates. Made from flexible Dura-Lar .030 PETG plastic film. Use to make multiple prints. Instruction guide included.

Packs of 24

NUMBER	SIZE	EACH	12/EA
A47182-1240	5" x 7"	\$46.16	\$41.54
A47182-1248	8" x 12"	86.11	77.50
A47182-1243	9" x 12"	86.11	77.50
A47182-1246	12" x 18"	173.47	156.12

Speedball® Printmaster® Paper Packs

For block printing and other printing and stamping applications.

Machine-made (85 gsm), true to characteristics of traditional Oriental block paper. Won't yellow or affect other surfaces adversely. Acid-free and pH-neutral.

50-Sheet Pack

NUMBER	SIZE	EACH	6/EA	12/EA
A10431-1023	9" x 12"	\$13.44	\$12.10	\$11.50
A10431-1006	12" x 18"	25.19	22.67	21.55
A10431-1009	18" x 24"	36.70	33.03	31.40

100-Sheet Pack

NUMBER	SIZE	EACH	6/EA	12/EA
A10431-1123	9" x 12"	\$23.38	\$21.05	\$19.99



Black Ink™ Block Printing Packs

These Thai-made printing papers are thin yet very strong, making them ideal for lino block printing, wood block printing, and silk screening. They're smooth on one side and lightly textured on the other. The bleached white and colored sheets are made of 100% kozo. The unbleached white sheets are made from a mix of kozo and bamboo. All sheets are 9" x 12", 45 gsm, and pH-neutral. 25-sheet packs.

NUMBER	DESCRIPTION	EACH	10/EA
A10449-6603	Bleached Mulberry	\$19.78	\$17.80
A10449-6613	Unbleached Mulberry	19.78	17.80

Assortment Packs — 24-sheet pack includes three each of Tea, Pear, Sky, Red, Purple, and Mustard, plus six Black sheets. 45-sheet packs contain five each of colors listed above, plus five each bleached and unbleached sheets.

NUMBER	DESCRIPTION	EACH	10/EA
A10449-1004	24 Sheets	\$19.78	\$17.80
A10449-1005	45 Sheets	34.62	31.16



Gelli Arts® Gel Printing Plates

These revolutionary printing plates look and feel like gelatin monoprinting plates — yet they're durable, reusable, and store at room temperature. Flexible and easy to use, they're always ready for printing and can easily be cleaned with gel hand sanitizer or soap and water. Try them for mixed media art, card making, quilt making, and more. 3/8" thick (16" x 20" plate is 5/16" thick).

3/8" Thick

NUMBER	DESCRIPTION	SIZE	EACH	6/EA
A47003-1004	Round	4"Dia	\$15.42	\$13.88
A47003-1008	Round	8"Dia	27.55	24.80
A47003-1035	Rectangle	3" x 5"	13.22	11.90
A47003-1057	Rectangle	5" x 7"	19.85	17.85
A47003-1066	Square	6" x 6"	19.83	17.85
A47003-1810	Rectangle	8" x 10"	29.47	26.78
A47003-1214	Rectangle	12" x 14"	60.62	54.55
A47003-1620	Rectangle	16" x 20"	132.29	119.05

9" x 12" Plate — This plate includes a Mylar sheet with 1" grid lines to help with composition. It's perfect for creating bleed prints on A4 and classic letter size papers. 5/16" thick.

NUMBER	EACH	6/EA
A47003-1912	\$40.79	\$36.71

Speedball® Gel Printing Plates

These gel printing plates make it easy for hobbyists and fine artists to create beautiful one-of-a-kind prints. Great for mixed media, card making, journaling, scrapbooking, home décor, and much more. Best if used with Speedball block printing and screen printing inks, or Akua™ Intaglio Inks and Liquid Pigments. Or use acrylics, oil paints, and dyes. Buy in bulk and save!

1/4" Thick

NUMBER	SIZE	EACH	6/EA
A37802-1055	5" x 5"	\$18.40	\$16.56
A37802-1057	5" x 7"	20.60	18.54
A37802-1810	8" x 10"	33.59	30.24
A37802-1212	12" x 12"	65.03	58.53
A37802-1155	5" x 5", 10-pack	150.71	135.70
A37802-1157	5" x 7", 10-pack	168.47	151.60
A37802-2810	8" x 10", 10-pack	271.68	244.50
A37802-2212	12" x 12", 10-pack	563.00	507.00

5" x 5" Speedball Gel Printing Class Pack — Everything you need to instruct and inspire a group of 30, including printing plates, inks, and brayers. For full contents, visit DickBlick.com.

NUMBER	EACH
A37802-2155	\$578.00



Gelli Arts™ Mini Gel Printing Plate Sets

Flexible and easy to use, these revolutionary printing plates look and feel like a gelatin monoprinting plate — yet they're durable, reusable, and can be stored at room temperature. These plates measure 3"W x 3/8" thick, perfect for printing and stamping on paper or fabric. Clean with soap and water, hand sanitizer, or baby wipes.

NUMBER	DESCRIPTION	EACH	6/EA
A47003-1009	Round/Square/Triangle	\$24.50	\$22.05
A47003-1019	Oval/Rectangle/Hexagon	24.50	22.05
A47003-1003	Octagon/Quatrefoil/Diamond	24.50	22.05



Gelli Arts™ Student Printing Mini Plate Class Packs

These sets contain 10 mini plates, 10 storage bags, five assorted stencils, and a comb. The easy-to-use printing plates are ideal for teaching all levels and ages. Non-toxic, latex-free, and silicone-free, they're durable, reusable, and can be stored at room temperature.

NUMBER	DESCRIPTION	EACH	6/EA
A47003-1059	Mini Circle, Pack of 10	\$88.19	\$79.39
A47003-1029	Mini Hexagon, Pack of 10	88.19	79.39
A47003-1049	Mini Square, Pack of 10	88.19	79.39
A47003-1039	Mini Triangle, Pack of 10	88.19	79.39

Assorted Pack of 24

NUMBER	EACH	6/EA
A47003-1069	\$198.45	\$178.60

Gel Press™ Printing Plates

Ideal for art educators, students, and fine artists, these reusable gel plates have a super-sensitive surface that captures fine textures and details in paint or ink. They can be mastered quickly and don't require expensive materials. Easy to clean.

3/8" Thick

NUMBER	DESCRIPTION	SIZE	EACH
A37841-1006	Circle	6"Dia	\$16.53
A37841-1035	Rectangle	3" x 5"	10.99
A37841-1000	Rectangle	5" x 7"	16.53
A37841-1012	Rectangle	8" x 10"	27.55
A37841-1066	Square	6" x 6"	16.53
A37841-1004	Square	12" x 12"	49.60
A37841-1003	Petites Set of 3	3" each	22.04
A37841-1266	Class Pack Set of 12	6" x 6" each	149.93



AKUA



Akua Liquid Pigment

These exceptionally rich, non-toxic, waterbased inks work great for all types of monotype techniques. Unique slow-drying formula allows plenty of time to create an image on the plate. Because Akua stays wet on the plate, there's no need to soak paper before printing. Clean,

brilliant, lightfast colors that are exceptionally strong yet transparent; no chalk, fillers, or polymers added. Use Akua modifiers to adjust sheen, thickness, and transparency. Cleans up fast and easy with water. Can also be used for Japanese woodcut and drawing on paper. 4 oz (118 ml) plastic bottles. Colors can be assorted for quantity pricing.

NUMBER	COLOR	EACH	6/EA
A40311-8044	Burnt Sienna	\$12.99	\$11.69
A40311-8054	Burnt Umber	12.99	11.69
A40311-3164	Crimson Red	17.15	15.43
A40311-4494	Diarylide Yellow	17.15	15.43
A40311-4704	Hansa Yellow	14.78	13.30
A40311-2044	Jet Black	13.23	11.91
A40311-2024	Lamp Black	13.23	11.91
A40311-4064	Lemon Yellow	12.99	11.69
A40311-5164	Phthalo Blue	14.78	13.30
A40311-5754	Phthalo Blue Green	14.78	13.30
A40311-7814	Phthalo Green Blue	14.78	13.30
A40311-7904	Phthalo Green Yellow	14.78	13.30
A40311-4724	Pyrrole Orange	17.15	15.43
A40311-3274	Quinacridone Red	17.15	15.43
A40311-6514	Quinacridone Violet	17.15	15.43
A40311-8074	Raw Umber	12.99	11.69
A40311-3124	Red Oxide	12.99	11.69
A40311-3084	Scarlet Red	17.15	15.43
A40311-1024	Titanium White	12.99	11.69
A40311-5234	Ultramarine Blue	14.78	13.30
A40311-4044	Yellow Ochre	12.99	11.69



Akua Printmaking Plate 3-Packs

Made of .030 PETG transparent plastic, these plates are durable, softer than polycarbonate with a non-porous surface, and perfect for inversion printing. They're ideal for monotype, carborundum, collagraph, drypoint, and Imago photopolymer film. Packs of three plates.

NUMBER	SIZE	EACH	6/EA
A47179-1021	6" x 8"	\$10.17	\$9.15
A47179-1812	8" x 12"	17.99	17.39
A47179-1006	12" x 16"	29.93	28.55



A-E Akua Modifiers

A Blending Medium — Use this clear liquid to thin Akua Liquid Pigment or Akua Intaglio Inks for brushwork or wash effects. Or use it as a resist for viscosity monotype. Water cleanup.

NUMBER	SIZE	EACH	6/EA
A40309-1002	4 oz (118 ml)	\$10.59	\$9.53

B Extender — Use it to thin Akua Liquid Pigment. Not recommended for Akua Intaglio Inks. Water cleanup.

NUMBER	SIZE	EACH	6/EA
A40311-1014	4 oz (118 ml)	\$10.59	\$9.53

C Retarder — Acts as a release agent for printing on dry paper and lengthens working time. Use with Akua Liquid Pigment only. Not recommended for Akua Intaglio Inks. Water cleanup.

NUMBER	SIZE	EACH	6/EA
A40311-1004	4 oz (118 ml)	\$10.59	\$9.53



Speedball Akua Gel Printing Kit

This seven-piece kit contains everything you need to create easy and fun one-of-a-kind prints. Professional-quality Akua Intaglio Inks are loaded with pigment and stay open for a very long time. They work beautifully with Speedball Gel Printing Plates. For details and more kits, visit DickBlick.com.

NUMBER	SIZE	EACH	6/EA
A37802-1017		\$49.50	



Artwork by Tina Browder

D Tack Thickener — This modifier thickens colors. Creating denser Akua Liquid Pigment roll-ups on monotype plates. Use only with Akua Liquid Pigment. Soap-and-water cleanup.

NUMBER	SIZE	EACH	6/EA
A40311-1034	4 oz (118 ml)	\$10.59	\$9.53

E Transparent Base — Use with both Akua Liquid Pigment and Akua Intaglio Inks. It thickens Akua Liquid Pigment and creates new intaglio colors. It also increases the transparency of Akua Intaglio Inks.

NUMBER	SIZE	EACH	6/EA
A40309-1000	8 oz (237 ml)	\$17.53	\$15.78



Akua Pin Press

An economical, portable press designed for light pressure printing processes such as monotype, drypoint, and collagraph, the Akua Pin Press features a 20" long roller. This press is precisely machined to an incredibly even, smooth surface for uniform contact between the roller, paper, and plate. Durable, all-metal construction ensures long-lasting, trouble-free printing.

NUMBER	EACH
A40329-1020	\$266.77



Akua Wiping Fabric

Ideal for wiping excess ink from the surface of an intaglio plate, this sturdy polyester fabric is long-lasting and lint-free. It's also less absorbent, smoother and softer than traditional turlatan. It can be reused hundreds of times.

NUMBER	SIZE	EACH	12/EA
A40222-1010	19"W x 10 yd	\$20.94	\$18.84

Creutex Monotype Colors

A monotype is a print created by transferring to paper an image that has been painted on a plate made of metal, glass, or plastic. Transfer occurs by hand-rubbing or using an etching or lithography press. Unlike oil-based inks, Creutex waterbased colors can dry before printing. The dampened paper will re-wet the color and transfer the image. Offers the ability to ink several plates at once, then transfer image later. Non-toxic, permanent. 8 oz (236 ml) bottles. Colors can be assorted for quantity pricing.

NUMBER	COLOR	EACH	12/EA
A00338-2005	Black	\$15.36	\$13.82
A00338-8045	Burnt Sienna	15.36	13.82
A00338-8055	Burnt Umber	15.36	13.82
A00338-6515	Carbazole Violet	15.36	13.82
A00338-5165	Cerulean Blue	15.36	13.82
A00338-5185	Cobalt Blue	15.36	13.82
A00338-3165	Crimson	15.36	13.82
A00338-9065	Earth Green	15.36	13.82
A00338-4085	Golden Yellow	15.36	13.82
A00338-7155	Leaf Green	15.36	13.82
A00338-3045	Magenta	15.36	13.82
A00338-4505	Orange	15.36	13.82
A00338-5148	Phthalo Blue	15.36	13.82
A00338-7805	Phthalo Green	15.36	13.82
A00338-3735	Primary Red	15.36	13.82
A00338-4535	Primary Yellow	15.36	13.82
A00338-8065	Raw Sienna	15.36	13.82
A00338-8075	Raw Umber	15.36	13.82
A00338-3125	Red Oxide	15.36	13.82
A00338-3085	Scarlet	15.36	13.82
A00338-5235	Ultramarine Blue	15.36	13.82
A00338-1005	White	15.36	13.82
A00338-4045	Yellow Orche	15.36	13.82

NUMBER	EACH	6/EA
A00338-0007	\$31.39	\$28.27

Sampler Set of 8 — Includes 4 oz (118 ml) bottles of White, Black, Primary Red, Primary Yellow, Phthalo Blue, Violet, Phthalo Green, and Monotype Base.

NUMBER	EACH	6/EA
A00338-1089	\$61.32	\$55.19

Pro Set of 12 — Includes 4 oz (118 ml) bottles of White, Black, Primary Red, Primary Blue, Orange, Phthalo Blue, Cobalt Blue, Violet, Phthalo Green, Raw Sienna, Burnt Umber, and Monotype Base.

NUMBER	EACH	6/EA
A00338-1109	\$92.05	\$82.83



Gamblin Ink Modifiers

Magnesium Carbonate — Use it to stiffen inks and reduce their gloss level without altering color. Works well with both Gamblin Etching Inks and Gamblin Artist's Colors Relief Inks.

NUMBER	SIZE	EACH
A40316-1006	16 oz (473 ml)	\$14.46

Tack Reducer — Add this gel in small amounts to efficiently reduce tack. Made from a very light, transparent drying oil, it does not alter color intensity.

NUMBER	SIZE	EACH
A40316-1004	5.1 oz (150 ml)	\$10.91



F Speedball Etching Press with Metal Bed

• Metal bed is made of strong, durable steel. The 12" x 24" bed is 6 mm thick. The 24" x 36" bed is 10 mm thick.
• Use press for etchings, monotype, and drypoint plates, woodcuts, and linocuts.
• Bottom-roller driven; choose a Direct Drive or Gear Drive press.
• Backed by a five-year warranty.

NUMBER	DESCRIPTION	EACH
A45041-1006	12" x 24" Press, Direct Drive	\$1157.00
A45041-1106	12" x 24" Press, Gear Drive	1432.00
A45041-1015	24" x 36" Press, Gear Drive	3747.00
A45041-1115	24" x 36" Press, Stand Only	524.00

G Speedball Etching Press with Phenolic Bed

• Phenolic bed is made of 6 mm thermoset resin, which is lighter than steel and won't warp or rust.
• Use press for etchings, monotype, and drypoint plates, woodcuts, and linocuts.
• Bottom-roller driven; choose a Direct Drive or Gear Drive press.
• Backed by a five-year warranty.

NUMBER	DESCRIPTION	EACH
A45043-1006	12" x 24" Press, Direct Drive	\$1046.00
A45043-1106	12" x 24" Press, Gear Drive	1322.00
A45043-1015	24" x 36" Press, Gear Drive	3306.00
A45043-1115	24" x 36" Press, Stand Only	524.00

Gamblin Artist's Colors Relief Inks

Gamblin Artist's Colors is proud to offer printmakers a palette of relief inks with an incomparably high pigment load. These inks give printmakers and monotype artists the intense colors, working properties, and archival quality they can count on. They print with unparalleled intensity, brilliant undertones, and sensitivity to printmakers' most finely detailed marks.

NUMBER	COLOR	EACH
A40318-4960	Hansa Yellow Light	\$24.71
A40318-3600	Naphthol Scarlet	24.71
A40318-5160	Phthalo Blue	24.71
A40318-7800	Phthalo Green	24.71
A40318-2090	Portland Intense Black	16.95
A40318-5220	Prussian Blue	20.21
A40318-3270	Quinacridone Red	20.21
A40318-8080	Sepia Relief	20.21
A40318-1020	Titanium White	16.95
A40318-1730	Transparent Base	16.95

NUMBER	DESCRIPTION	EACH
A40316-0000	Burnt Plate Oil #000	\$10.91
A40318-1002	Burnt Plate Oil #2	10.91



PRESSES

Pronto-Plate 5000*

If you're interested in non-toxic fine art printmaking, the Pronto-Plate 5000 is the solution you've been waiting for! Costing half the price of metal plates (and competitive with the cost of silver-based plates), Pronto-Plate is also the most efficient option for direct-to-plate printing in smaller offset printing applications by eliminating hardware, harmful chemicals, and consumables such as developers, fixers, film negatives, masking, plate cleaners, and plate etches. For product details, visit DickBlick.com.

NUMBER	SIZE	EACH	12/EA
A47004-1085	8-1/2" x 11"	\$0.67	\$6.60
A47004-1006	12" x 18"	1.55	1.39
A47004-1824	18" x 24"	5.17	4.66

Schmincke® College® Linol Linoprint Set

These odorless, water-mixable colors offer an easy intro to linoprint techniques. Colors dry to a wipe-resistant finish in as little as 15 minutes. Use them to make prints on paper, felt, and cardboard. They can also be used for wood engraving and material prints. Clean up with water. Not water-resistant. Set contains five 2.5 oz (75 ml) student-quality colors. For more info, visit DickBlick.com.

NUMBER	EACH
A37300-1059	\$63.55



Charbonnel™ Aqua Wash® Etching Inks

Water-washable inks with an oil emulsion that allows work similar to traditional solvent-based inks. Made from extra-fine quality pigments, they're very lightfast and permanent when dry. Excellent for all techniques, including intaglio, relief, etching, and woodcut on linoleum, monotype, aquatint, and more. Formulated especially for artists and students working in groups, the inks clean up without solvents and are non-toxic, odorless, and easy to wipe.

2 oz (60 ml) Tubes		
NUMBER	COLOR	EACH
A40323-8253	Basic Bistre	\$20.18
A40323-2023	Black 55981	19.82
A40323-2043	Black 55985	19.82
A40323-2033	Black F66	19.82
A40323-2053	Black Luxe	19.82
A40323-2013	Black RSR	19.82
A40323-1013	Burnt Sienna	19.82
A40323-2123	Carbon Black	19.82
A40323-3223	Cardinal Red	22.99
A40323-4323	Deep Yellow	22.99
A40323-7053	Emerald Green	20.18
A40323-5323	Ocean Blue	20.18
A40323-2563	Payne's Grey	19.82
A40323-4173	Primrose Yellow	22.99
A40323-5223	Prussian Blue	20.18
A40323-8913	Raw Sepia	19.82
A40323-8523	Sanguine	22.99
A40323-1183	Snow White Titan	20.18
A40323-5233	Ultramarine Blue	19.82
A40323-3283	Vermilion Red	22.99
A40323-8543	Warm Sepia	22.99
A40323-4043	Yellow Ochre	19.82

5 oz (150 ml) Tubes		
NUMBER	COLOR	EACH
A40323-2024	Black S1 55981	\$28.43
A40323-2044	Black S1 55985	28.43
A40323-2034	Black S1 F66	28.43
A40323-2054	Black S1 Luxe C	28.43
A40323-2014	Black S1 RSR	28.43
A40323-2124	Carbon Black S1	28.43

Hanco Ink™ Modifiers

Hanco Ink Modifiers are used to stiffen inks and slow the drying process. 1 lb containers.

French Chalk — Used to dust the image area of a plate prior to etching, this chalk contains the finest, softest white talcum powder.

NUMBER	EACH	6/EA
A45218-1001	\$9.71	\$8.74

Magnesium Carbonate — A white powder used to stiffen and shorten the body of inks.

NUMBER	EACH	6/EA
A45218-1002	\$12.71	\$11.44

Setswell Compound — A versatile additive that slows drying to keep ink layers open. It can also be used to reduce tack and body.

NUMBER	EACH	6/EA
A45218-1006	\$19.75	\$17.77

Hanco Ink™ Litho Varnishes

Hanco Litho Varnish is a commonly used ink modifier produced by heating linseed oil to create a variety of viscosities ranging from the thin-bodied #00 varnish to a heavier-bodied #7 varnish. Use it to increase the body of an ink when using a stiffer varnish or to soften an ink when using thinner-bodied varnishes. Pints.

NUMBER	DESCRIPTION	EACH	6/EA
A45218-1000	#00	\$14.87	\$13.39
A45218-1003	#3	14.87	13.39
A45218-1005	#5	14.87	13.39
A45218-1007	#7	14.87	13.39



A Cranfield Caligo Safe Wash Oil

Use this oil to dilute Cranfield Caligo Safe Wash Inks.

NUMBER	SIZE	EACH
A40319-1191	8.45 oz (250 ml) Jar	\$17.54

B Cranfield Caligo Wiping Compound

Modify the tack of Cranfield Caligo Safe Wash Inks.

NUMBER	SIZE	EACH
A40319-1094	5 oz (150 ml) Tube	\$21.83
A40319-1095	17.6 oz (500 g) Jar	34.30

C Cranfield Caligo Transparent Extenders

Use the Transparent Extender to control the color strength of Cranfield Caligo Safe Wash Etching Inks.

NUMBER	SIZE	EACH
A40319-1003	2.53 oz (75 ml)	\$11.89
A40319-1004	5.07 oz (150 ml)	18.68
A40319-1002	8.81 oz (250 g)	21.04
A40319-1005	17.63 oz (500 g)	37.44



D Akua Mag Mix

Mag Mix — Use this ink stiffener to thicken and add body to Akua Intaglio Inks. Perfect for relief and intaglio plates that require a stiffer ink as well as letterpress and viscosity printing. Soap-and-water cleanup.

NUMBER	SIZE	EACH	6/EA
A40309-1001	8 oz (237 ml)	\$17.53	\$15.78

E Akua Release Agent

Akua Release Agent is used for monotype ghost prints, to create high shine in Akua Intaglio metallic colors, or when doing monotype prints with Akua Liquid Pigment. Akua Release Agent acts to soften the pigments on the printmaking plate, enhancing their vibrancy and appearance after printing.

NUMBER	SIZE	EACH	6/EA
A40309-1005	8 oz (237 ml)	\$16.07	\$14.46

CRANFIELD

Cranfield Caligo Safe Wash Etching Ink

These oil-based etching inks feel and work like traditional oil-based inks, yet clean up with soap and water — no solvents required! Made from the finest single pigments and polymerized vegetable oil, they're excellent for all kinds of intaglio printmaking, including etching, engraving, aquatint, drypoint, and carborundum. Made without driers, they dry like traditional etching inks and can be printed on a wide range of papers with the quality, intensity, and precision of an oil-based ink.

COLOR	2.5 OZ (75 ML)		5 OZ (150 ML)		8.8 OZ (250 GM) JAR		17.6 OZ (500 GM) JAR	
	TUBES	EACH	TUBES	EACH	EACH	EACH	EACH	EACH
Arylide Yellow	A40319-4913	\$13.84	A40319-4914	\$19.69	A40319-4912	\$21.56	A40319-4915	\$39.65
Blue-Black	A40319-2093	11.89	A40319-2094	18.68	A40319-2092	21.04	A40319-2095	37.44
Brown-Black	A40319-8343	11.89	A40319-8344	18.68	A40319-8342	21.04	A40319-8345	37.44
Carbazole Violet	A40319-6553	18.47	A40319-6554	27.26	A40319-6552	32.54	A40319-6555	59.80
Carbon Black	A40319-2023	11.89	A40319-2024	18.68	A40319-2022	21.04	A40319-2025	37.44
Diarylide Yellow	A40319-4493	13.84	A40319-4494	19.69	A40319-4492	21.56	A40319-4495	39.65
Naphthol Red	A40319-3603	16.60	A40319-3604	18.99	A40319-3602	22.75	A40319-3605	43.10
Opaque White	A40319-1083	12.26	A40319-1084	18.44	A40319-1082	18.98	A40319-1085	34.40
Phthalo Green	A40319-7803	19.12	A40319-7804	22.48	A40319-7802	30.33	A40319-7805	57.79
Process Blue	A40319-5513	12.79	A40319-5514	20.20	A40319-5512	20.29	A40319-5515	41.06
Process Red	A40319-3713	19.13	A40319-3714	29.20	A40319-3712	34.23	A40319-3715	59.40
Prussian Blue	A40319-5223	12.79	A40319-5224	27.31	A40319-5222	29.09	A40319-5225	51.65
Rubine Red	A40319-3743	12.79	A40319-3744	20.20	A40319-3742	27.56	A40319-3745	47.27
Sepia	A40319-8083	12.26	A40319-8084	18.44	A40319-8082	18.98	A40319-8085	34.40
Ultramarine					A40319-5232	28.68	A40319-5235	42.95
Yellow Ochre	A40319-4043	12.26	A40319-4044	19.75	A40319-4042	25.87	A40319-4045	36.81

AKUA



Akua Intaglio™ Inks

These soy-based, environmentally safe, permanent inks are safe to use without special ventilation, toxic solvents, or fireproof containers. They're formulated for intaglio yet can be applied with a brayer for relief, monotype, and collagraph techniques — or combine with Solarplate for a completely waterbased intaglio process. They have a rich, thick consistency with minimal dryer. Soap-and-water cleanup. For plastic, linoleum, wood, or metal plates. Colors can be assorted for quantity pricing.

8 oz (237 ml) Jars			
NUMBER	COLOR	EACH	6/EA
A40309-2100	Bone Transparent Bk	\$18.64	\$16.77
A40309-8040	Burnt Sienna	20.33	18.30
A40309-8050	Burnt Umber	20.33	18.30
A40309-3234	Carbazole Violet	24.85	22.36
A40309-6510	Carbon Black	18.64	16.77
A40309-2120	Crimson Red	24.85	22.36
A40309-4490	Diarylide Yellow	24.85	22.36
A40309-2610	Graphite	18.64	16.77
A40309-4700	Hansa Yellow	21.45	19.31
A40309-2020	Lamp Black	18.64	16.77
A40309-2040	Mars Black	18.64	16.77
A40309-1080	Opaque White	21.45	19.31
A40309-7110	Oxide Green	20.33	18.30
A40309-2560	Payne's Gray	18.64	16.77
A40309-5160	Phthalo Blue	21.45	19.31
A40309-7800	Phthalo Green	21.45	19.31
A40309-5234	Prussian Blue	21.45	19.31
A40309-4920	Pyrrrole Orange	24.85	22.36
A40309-3620	Quatricridone Magenta	24.85	22.36
A40309-8070	Raw Umber	20.33	18.30
A40309-3120	Red Oxide	20.33	18.30
A40309-3080	Scarlet Red	24.85	22.36
A40309-1020	Titanium White	20.33	18.30
A40309-1000	Transparent Base	17.53	15.78
A40309-5230	Ultramarine Blue	21.45	19.31
A40309-8310	Van Dyke Brown	20.33	18.30
A40309-4040	Yellow Ochre	20.33	18.30



8-Color Sampler Pack — Carbon Black, Crimson Red, Hansa Yellow, Phthalo Blue, Phthalo Green, Red Oxide, Titanium White, and Yellow Ochre in 2 oz (59 ml) jars.

NUMBER	EACH	12/EA
A40314-1009	\$74.34	\$66.91

FREE SHIPPING —
Orders of \$49 or more
ship free.

CHARBONNEL™

Charbonnel™ Etching Inks

Intricate detail and subtle inflections come to life with Charbonnel inks. The top choice of the most exacting printmakers, Charbonnel inks feature pigments chosen for their low acidity and exceptional lightfastness. Blended with top-quality oils and carefully milled to ensure trouble-free printing, these are the inks to choose for exquisite, lasting works of art.

Colors can be assorted for quantity pricing.

6.7 oz (200 ml) Cans				6.7 oz (200 ml) Cans			
NUMBER	COLOR	EACH	6/EA	NUMBER	COLOR	EACH	6/EA
A45216-4584	Apricot Yellow	\$63.73	\$57.36	A45216-7554	Permanent Green Lake	\$77.34	\$69.61
A45216-8254	Bistre	46.93	42.24	A45216-6914	Permanent Violet	77.34	69.61
A45216-2024	Black F66	40.04	36.03	A45216-3714	Perm Viridian Lake	63.73	57.36
A45216-2004	Black Luxe C	46.93	42.24	A45216-4934	Perm Yellow Lake	63.73	57.36
A45216-2044	Black RSR	40.04	36.03	A45216-4174	Primrose Yellow	63.73	57.36
A45216-2014	Black Universal 55981	46.93	42.24	A45216-5224	Prussian Blue	57.96	52.16
A45216-2034	Black Very Dense	46.93	42.24	A45216-8064	Raw Sienna	46.93	42.24
A45216-8044	Burnt Sienna	46.93	42.24	A45216-8094	Raw Sepia	46.93	42.24
A45216-8054	Burnt Umber	46.93	42.24	A45216-8074	Raw Umber	46.93	42.24
A45216-3814	Cardinal Red	63.73	57.36	A45216-3734	Red Ochre	40.04	36.03
A45216-3154	Carmine Red	72.29	65.06	A45216-3374	Ruby Red	77.34	69.61
A45216-5164	Cerulean Blue	46.93	42.24	A45216-8914	Sanguine	46.93	42.24
A45216-5184	Cobalt Blue	46.93	42.24	A45216-7094	Sap Green	63.73	57.36
A45216-8084	Colored Sepia	46.93	42.24	A45216-1184	Snow White	46.93	42.24
A45216-5814	Concentrated Blue	77.34	69.61	A45216-1174	Snow White Zinc	46.93	42.24
A45216-4324	Deep Yellow	57.96	52.16	A45216-2234	Soft Black	40.04	36.03
A45216-7054	Emerald Green	63.73	57.36	A45216-6514	Solferino Violet	77.34	69.61
A45216-3744	Geranium Red	63.73	57.36	A45216-7334	Spring Green	63.73	57.36
A45216-4164	Indian Yellow	63.73	57.36	A45216-5114	Turquoise Blue Lake	46.93	42.24
A45216-4064	Lemon Yellow	63.73	57.36	A45216-5234	Ultramarine	46.93	42.24
A45216-3724	Madder Lake	72.29	65.06	A45216-8314	Van Dyck Brown	57.96	52.16
A45216-7024	Medium Green	57.96	52.16	A45216-3284	Vermilion Red	63.73	57.36
A45216-4914	Nasturtium Yellow	77.34	69.61	A45216-3774	Warm Red	72.29	65.06
A45216-5914	Ocean Blue	63.73	57.36	A45216-4044	Yellow Ochre	40.04	36.03
A45216-5894	Orient Blue	57.96	52.16				
A45216-2564	Payne Gray	40.04	36.03				



KORN'S



Korn's Lithographic Crayons

These dense, black crayons are made with the same great materials used in Korn's Lithographic Pencils, but they're in stick form. Box of 12.

NUMBER	DESCRIPTION	EACH	12/EA
A48905-1009	#1 Soft	\$13.29	\$11.96
A48905-1109	#2 Medium	13.29	11.96



Korn's Autographic Ink

A solid, greasy ink for drawing in silkscreen or lithography. It produces rich blacks directly on surfaces and can be used as a transfer ink for copying.

NUMBER	SIZE	EACH
A38008-1003	2 oz (59 ml)	\$65.03
A38008-1004	4 oz (118 ml)	99.21
A38008-1005	8 oz (236 ml)	154.33
A38008-1006	16 oz (473 ml)	211.07



Speedball Flexible Printing Plates

Made of a vinyl material that's 1/16" thick (approximately 1.5 mm), these plates are soft and flexible with a smooth tan surface on one side and self-adhering adhesive on the back. Cut the plate and mount it on a base, such as cardboard. Shapes can be cut with school scissors. Carve fine lines with linoleum cutters. Ink with either oil-based or waterbased inks, and print using a press, baren, brayer, or rubbing tool.

NUMBER	SIZE	EACH	3/EA
A44045-1001	6" x 9", 12-Pack	\$39.64	\$35.68
A44045-1003	9" x 12", 12-Pack	99.20	89.28



Copper Etching Plates, 18-Gauge

These 18-gauge unpolished copper plates are ideal for etching, drypoint, and aquatint. The surface may be polished to photo engraver's quality prior to etching if desired. The back of the plate requires stopping-out prior to etching.

NUMBER	SIZE	EACH	6/EA
A47006-9504	4" x 6"	\$11.50	\$10.31
A47006-9501	6" x 8"	21.85	19.59
A47006-9503	9" x 12"	48.30	43.30
A47006-9506	12" x 18"	94.30	84.54
A47006-9509	18" x 24"	178.25	159.81



Richeson Clear Carve™ Etching Plates

These plates are clear, so it's easy to trace and etch designs. Available in a variety of sizes, these wallet-friendly etching plates are perfect for beginning printmakers. Use them for etching, monotype, and drypoint. Made of clear PETG plastic. 0.03" (0.75 mm) thick.

NUMBER	SIZE	EACH	12/EA
A40445-1000	5" x 7"	\$5.69	\$5.18
A40445-1012	8" x 10"	11.38	10.24
A40445-1023	9" x 12"	14.92	13.93
A40445-1006	12" x 16"	25.18	23.69
A40445-1002	22" x 30"	27.34	24.60

NUMBER	EACH
A40445-1100	\$48.72

Richeson Twisted Etching Tool

Use this double-ended tool to carve Clear Carve™ Etching Plates and other printmaking surfaces. Sturdy and sharp, it's easy to hold and has a comfortable grip. 7" long.

NUMBER	EACH	12/EA
A30575-1007	\$8.73	\$7.82

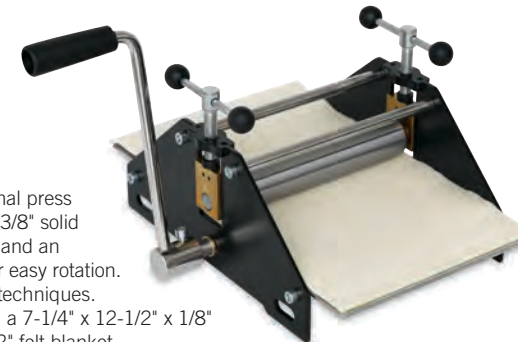

Blick Baby Press Package

Made in Italy, this durable, professional press features heavy-duty casting with a 1-3/8" solid steel roller, precise pressure control, and an ergonomically constructed handle for easy rotation. It's ideal for a variety of printmaking techniques. Package includes the 7" Baby Press, a 7-1/4" x 12-1/2" x 1/8" steel bed plate, and a 7-1/4" x 12-1/2" felt blanket.

NUMBER	EACH
A40019-1009	\$525.00

Baby Press Pusher Blanket — This dense gray felt blanket helps pull the print surface through the roller while equalizing pressure and strain on the roller.

NUMBER	EACH
A43030-1020	\$45.98

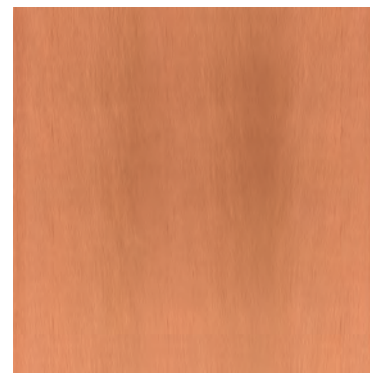

Copper Etching Plates

These unpolished printmaking plates are great for etching and intaglio. The plates are available in two thicknesses, 14-gauge (0.064") and 16-gauge (0.050") and a variety of popular sizes. Made in the USA.

NUMBER	SIZE	THICKNESS	EACH	6/EA
A47005-8546	4" x 6"	0.050"	\$9.94	\$8.95
A47005-8557	5" x 7"	0.050"	12.68	11.41
A47005-8569	6" x 9"	0.050"	19.09	17.19
A47005-8510	8" x 10"	0.050"	27.55	24.79
A47005-8512	9" x 12"	0.050"	37.85	34.06
A47005-8518	12" x 18"	0.050"	74.45	66.99
A47005-8646	4" x 6"	0.064"	11.65	10.49
A47005-8657	5" x 7"	0.064"	16.11	14.49
A47005-8669	6" x 9"	0.064"	24.92	22.43
A47005-8610	8" x 10"	0.064"	35.56	31.99
A47005-8612	9" x 12"	0.064"	46.99	42.30
A47005-8618	12" x 18"	0.064"	86.93	78.23

Zinc Etching Plates

Use these 16-gauge, professional-quality plates for etching, drypoint, and aquatint. The surface is polished, and an acid-resistant back eliminates stopping-out before etching.

NUMBER	SIZE	THICKNESS	EACH	6/EA
A47008-0046	4" x 6"	0.064"	\$8.69	\$7.82
A47007-1068	6" x 8"	0.064"	20.99	18.92
A46921-1008	8" x 10"	0.064"	35.04	31.53
A47007-1912	9" x 12"	0.064"	46.71	42.04
A47007-1218	12" x 18"	0.064"	84.08	75.67
A47007-1824	18" x 24"	0.064"	151.81	136.63



The Super Tub

Versatile tub for a number of projects, including etching, paper making, and fabric dyeing. Made of durable, heavy-duty black plastic. 8" deep. Bottom measures 30" x 22".

NUMBER	EACH	3/EA
A46904-0000	\$30.38	\$27.34

HANCO INK™

Hanco Ink™ Oil Based Etching Inks

Manufactured to exacting standards using only the finest raw materials, these oil-based etching inks are ground between hardened steel rolls to achieve full strength and reveal even the finest print details.

Colors can be assorted for quantity pricing.

1 lb (473 ml) Cans			
NUMBER	COLOR	EACH	12/EA
A44238-2096	Blue Black	\$19.73	\$17.76
A44238-2106	Bone Black	19.25	17.33
A44238-8716	Burnt Sienna	19.48	17.54
A44238-8636	Burnt Umber	19.44	17.50
A44238-6506	Carbazole Violet	27.53	24.78
A44238-5186	Cobalt Blue	22.30	20.07
A44238-3166	Crimson Red	20.54	18.49
A44238-8036	Dark Brown	18.77	16.90
A44238-3036	Dark Red	23.25	20.92
A44238-2146	Intense Deep Black	19.73	17.33
A44238-4026	Lemon Yellow	20.54	18.49
A44238-7026	Medium Green	21.14	19.03
A44238-3716	Medium Red	21.48	19.33
A44238-5806	Midnight Blue	22.66	20.40
A44238-5016	Milori Blue	21.59	19.43
A44238-6716	Opaque White	23.64	21.28
A44238-4516	Orange	21.59	19.43
A44238-2566	Paynes Gray	20.66	18.60
A44238-5166	Phthalo Blue	21.25	19.13
A44238-7806	Phthalo Green	24.41	21.97
A44238-2026	Process Black	19.48	17.54
A44238-5516	Process Cyan	21.03	18.91
A44238-3726	Process Magenta	22.07	19.86



GAMBLIN

Gamblin Etching Inks

These inks have a following among discerning printmakers because of their high pigment load, excellent working properties, and incredible sensitivity to the printmaker's marks. Handcrafted in small batches in Portland, Oregon.

1 lb (473 ml) Cans

NUMBER	COLOR	EACH
A40316-2101	Bone Black	\$21.82
A40316-2121	Carbon Black	21.82
A40316-6021	Dioxazine Purple	31.63
A40316-1491	Etching White	21.82
A40316-2201	Graphite	27.26
A40316-4221	Hansa Yellow Light	31.63
A40316-3601	Naphthol Red	27.26
A40316-7801	Phthalo Green	27.26
A40316-2191	Portland Black	21.82
A40316-2291	Portland Cool Black	21.82
A40316-5221	Prussian Blue	27.26
A40316-3271	Quinacridone Red	31.63
A40316-8081	Sepia	27.26
A40316-2391	Stiff Portland Black	21.82
A40316-1001	Transparent Base	21.82
A40316-5231	Ultramarine Blue	27.26
A40316-4041	Yellow Ochre	21.82



HEALTH & SAFETY ICONS: ●=CL / ■=Prop 65 / ▼=CL & Prop 65 See page 644 for more information.

WARNING! Products marked with a Prop 65 symbol (■ or ▼) can expose you to chemicals, including cadmium, which are known to the State of California to cause cancer and birth defects or other reproductive harm. For more information, visit P65Warnings.ca.gov.

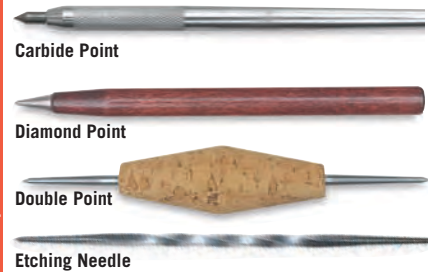

Etching & Drypoint Scribes
Perfect tools for drypoint. Resharpen as needed.

Carbide Point Scribe — Steel handle. 6" long.
NUMBER EACH 12/EA
A40219-1010 \$12.12 \$10.91

Diamond Point Scribe — Tempered steel with a diamond tip encased in a wooden, pencil-style barrel. Ideal for producing fine lines on zinc and copper or for etching glass. 5-1/2" long.
NUMBER EACH 12/EA
A45212-1001 \$22.04 \$19.84

Double Point Scribe — Traditional double-edge steel tips and a comfortable cork grip. Ideal for both beginners and seniors who have trouble grasping a thin etching needle. 6" long.
NUMBER EACH 12/EA
A45212-1002 \$12.94 \$11.65

Twisted Etching Needle — Solid steel. Tapered point on both ends. 6-3/4" long.
NUMBER EACH 12/EA
A45212-0000 \$8.61 \$7.75



Burins Set of 6 Gravers
These gravers have wooden handles that fit comfortably into the palm of your hand for producing woodcuts and metal engravings. Each of the tempered steel rods has a different end. Total length of each graver is 4-3/4".
NUMBER EACH 6/EA
A45101-1009 \$74.99 \$67.50

Triangular Scraper — An essential tool for the printmaker used to clean up plate edges or make changes to an image. Can be resharpened.
NUMBER EACH 12/EA
A45108-0000 \$12.22 \$10.99

Small Scraper — 5-3/4" long.
NUMBER EACH 12/EA
A45102-1058 \$11.89 \$10.70



EC Lyons Mezzotint Rockers
Known as the finest in the world, EC Lyons Mezzotint Rockers are made using high-carbon tool steel to produce rich, velvety black tones. Rockers are 7" long with a medium (85 gauge) screen and stained birch handle.

NUMBER	SIZE	EACH	12/EA
A45107-1025	2-1/2" Wide	\$144.71	\$130.30
A45107-1004	4" Wide	202.59	182.30

EC LYONS etching tools

Edward C. Lyons has manufactured professional printmaking and engraving tools since 1898. Handcrafted in the USA, these tools are made from high-quality American steel. They're created to stand up to years of use and enjoyment.

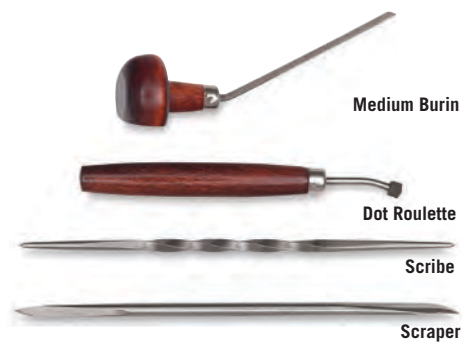

4 Piece Roulette Intaglio Etching Set
Includes a scraper/burnisher, 85 dot roulette, twisted double-point scribe, and medium square burin.
NUMBER EACH 6/EA
A45110-1049 \$76.27 \$68.65



6 Piece Intaglio Etching Set
Includes a small 6-3/4"L carving burnisher, twisted double-point scribe, small scraper, medium elliptical tint burin, 4-3/4"L medium square burin, and small lozenge burin.
NUMBER EACH 6/EA
A45110-1069 \$70.10 \$63.09



Sharpening Stones
A variety of sharpening stones for maintaining an edge. The small, extra-fine Arkansas silicon quartz is the aristocrat of sharpening stones. Large round and medium rectangular double-sided India stones are impregnated with petroleum-based honing oil to protect the stone, carry away debris, and more efficiently produce a keen edge.

NUMBER	DESCRIPTION	EACH
A40217-1010	Small Ultra Fine	\$35.23
A40217-1030	Med Rect Medium/Fine	19.77
A40217-1020	Lg Round Medium/Fine	30.58

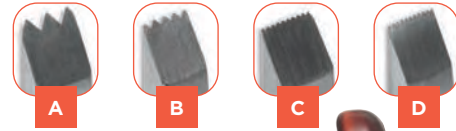

A-D Intaglio Multi Liners
Save time and build up tone with these multiple line tools. Each tool produces a series of lines with one stroke. The 1/8" tools are made from the highest-quality tool steel, which is hardened and tempered to hold its cutting edge. Polished wood handles offer the ultimate control. Can be resharpened.

NUMBER	DESCRIPTION	EACH	12/EA
A45114-1025	A 25 lines/inch	\$44.80	\$40.32
A45114-1045	B 45 lines/inch	44.80	40.32
A45114-1085	C 85 lines/inch	44.80	40.32
A45114-1100	D 100 lines/inch	44.80	40.32



Round Etching and Litho Needle
With a tip made of high-carbon tool steel, this .97 mm diameter etching/litho needle is great for fine details. Use it for etching, lithography, drypoint, and stippling. The tool has a wood handle and measures 8" long. Made in the USA.
NUMBER SIZE EACH 12/EA
A40240-1002 2 \$9.35 \$8.42



E-I Burnishers
E Steel Burnishers — Highly polished and perfect for creating tones and highlights on a mezzotint or aquatint plate. Use in conjunction with a scraper to remove unwanted lines. Style 1 is curved, 6-3/4" in overall length, and has a wooden handle. Style 2 is 7" long with a curved end and a needle-pointed end.
NUMBER STYLE EACH 12/EA
A45105-1064 1 \$12.10 \$10.89
A45106-1007 2 13.18 11.86

F Small Curved Burnisher — 5-1/2" long.
NUMBER EACH 12/EA
A45104-0000 \$11.97 \$10.77

G Scraper/Burnisher — 7" long.
NUMBER EACH 12/EA
A45103-1007 \$25.91 \$23.32

H Intaglio Slim Burnisher — Highly polished, curved finishing tool fits in hand with ease. At 6-3/4" long, it's perfect for intricate work, allowing the user to manipulate within delicate areas.
NUMBER EACH 12/EA
A45100-1002 \$11.97 \$10.77

I Ball Burnisher — A small, ball-shaped burnisher for detail work, flattening burrs, polishing the plate surface, image-making, or making corrections.
NUMBER EACH 12/EA
A40239-1001 \$9.42 \$8.48

Conrad™ Presses
Small professional presses with the features and quality demanded by the professional artist, built to withstand the rigors of classroom use. Backed by a 25-year manufacturer's warranty, Conrad presses are made entirely in the USA with no outsourced parts. All presses are shipped FOB from Whitehall, Michigan. Most other small etching presses are made with inadequate gearing or no gearing at all, but Conrad presses are designed with the same professional features available on much larger presses. The most remarkable feature is the planetary all gear 6:1 reduction drive available on Deluxe models. The base of the press extends the full length of the bed plate. The vertical frame is constructed of 1-1/4" square Aircraft Alloy Aluminum for maximum strength with minimum weight. The upper roll is spring counterbalanced to maintain height adjustment. Optional micro-gauges offer the barrel-thimble design calibrated to .005" per line. This means that you can adjust each pressure screw by about the same thickness as a human hair! Now, due to the ever-increasing popularity of the monotype press, Conrad is offering a line of these inexpensive, large-capacity, portable tabletop presses (see below for details). Truck Shipment and FOB Factory. See page 648 for details.

Features of the Conrad™ E-12 Standard Press:

- Direct drive with 34" Diameter star wheel handle.
- Large counterbalanced upper roll, 3" Diameter.
- 12"W x 24"L x 1/2" thick Benelex, high density lignin-resin laminate bed plate.
- Optional Micrometer gauge.
- Shipping weight 83 lb.

Added Features of the Conrad™ E-12 Deluxe Press:

- Geared planetary reduction drive with 10" hand crank; 6:1 gear ratio.
- Large counterbalanced upper roll, 3" Diameter.
- 12"W x 24"L x 1/2" thick Benelex, high density lignin-resin laminate bed plate.
- Optional Micrometer gauge.
- Shipping weight 83 lb.

NUMBER	DESCRIPTION	EACH
AF45017-1000	Standard E-12 Press	\$1225.00
AF45017-1001	Deluxe E-12 Press	1780.00
AF45017-1002	Micrometer Gauge for E-12 Press	320.00
AF46909-1012	Set of 3 Blankets for E-12 Press	77.16

Features of the Conrad™ E-15 Standard Press:

- Direct drive with 34" Diameter star wheel handle.
- Large counterbalanced upper roll, 3" Diameter.
- 15"W x 30"L x 1/2" thick Benelex high density lignin-resin laminate bed plate.
- Optional Micrometer gauge.
- Shipping weight 146 lb.

Added Features of the Conrad™ E-15 Deluxe Press:

- Geared planetary reduction drive with 10" hand crank; 6:1 gear ratio.
- Large counterbalanced upper roll, 4-1/2" Diameter.
- 15"W x 30"L x 1/2" thick Benelex, high density lignin-resin laminate bed plate.
- Optional Micrometer gauge.
- Shipping weight 146 lb.

NUMBER	DESCRIPTION	EACH
AF45017-2000	Standard E-15 Press	\$1975.00
AF45017-2001	Deluxe E-15 Press	2585.00
AF45017-2002	Micrometer Gauge for E-15 Press	338.00
AF46909-1015	Set of 3 Blankets for E-15 Press	119.04

Features of the Conrad™ E-18 Standard Press:

- Direct drive with 34"Dia star wheel handle.
- Large counterbalanced upper roll, 4-1/2" Diameter.
- 18-3/4"W x 36"L x 3/4" thick Benelex, high density lignin-resin laminate bed.
- Optional Micrometer gauge.
- Shipping weight 297 lb.

NUMBER	DESCRIPTION	EACH
AF45017-3000	Standard E-18 Press	\$3619.00
AF45017-3001	Micrometer Gauge for E-18 Press	419.00
AF46909-1018	Set of 3 Blankets for E-18 Press	169.75

Conrad™ Monotype Presses
These presses break down into three parts to fit through a standard 30" door. Features: 6:1 geared enclosed planetary hand drive, bed plate made of 3/4" thick composite Benelex, 4" diameter solid steel upper and lower rolls (upper spring counterbalanced), 4 ft diameter open direct-drive star wheel. Ideal for light pressure applications such as monotypes, woodcuts, and linocuts. Can be used as a small etching press. Micrometer gauge and stand optional. FOB Factory. See page 648 for details.

NUMBER	SIZE	EACH
AF40018-1018	18"	\$2444.00
AF40018-1022	22"	3137.00
AF40018-1024	24"	3483.00

CONRAD™



25-year WARRANTY on all Conrad Presses



Conrad™ C-16 Multi-Media Press
The only press on the market that prints all mediums including bed plate stone lithography, which is not possible with traditional presses. Plus, it changes from intaglio to litho in as little as five minutes. Additional features include heavy, one-piece steel beam construction, 16" x 32" x 3/4" composite bedplate, 4-1/2" diameter upper roll and solid steel lower roll. Easily disassembled into component parts for cleaning and relocation. The optional steel stand and casters provide a sturdy home for your press as well as convenient portability. The C-16 includes a handle crank and 6:1 gear drive. 16" x 32" bedplate; 30"H x 28"W x 60"L overall. Shipping weight is 220 lb. The C-25 has a twin torque drive and 4:1 gear drive with four-spoke star wheel. 27" x 48" bedplate; 30"H x 39"W x 64"L overall. Shipping weight is 550 lb. FOB Factory. See page 648 for details.

NUMBER	DESCRIPTION	EACH
AF45035-1016	C-16 Etching Press	\$3408.00
AF45035-1116	C-16 Felts	130.38
AF45035-2016	C-16 Micrometer	554.00
AF45035-3016	C-16 Steel Stand	565.00
AF45035-1025	C-25 Etching Press	5311.00
AF45035-1125	C-25 Felts	294.68
AF45035-2025	C-25 Micrometer	554.00
AF45035-3025	C-25 Steel Stand	691.00
AF45035-1004	4" Casters For Both Models	318.00

BLICK® handcrafted presses



Blick' Econo Etch Model II Press

Perfect for the beginner, or for portability!

- For etching, collagraphy, paper plate lithography, unmounted linoleum block printing, and embossing. Ideal for smaller prints and greeting cards.
- Features solid steel rolls.

- Direct-drive press; lower roll turns 360° when the handle turns 360°.
- Total clearance without blanket is 15/16".
- Includes 1/4" gray cushion blanket.
- Purchase of a catcher blanket and pusher blanket are recommended.
- Requires more effort to pull a print than in a geared press, but effort is still moderate.

NUMBER	DESCRIPTION	WEIGHT	EACH
A45029-1001	Press Only	38 lb	\$886.00

Wool Blankets for Econo Etch Model II

Made of fine-quality, dense wool felt.

NUMBER	COLOR	SIZE	EACH
A46911-1210	Gray	1/4" thick x 10-1/2" x 19"	\$16.87
A46911-1110	White	1/4" thick x 10-1/2" x 19"	44.55

NUMBER	SIZE	EACH
A46911-1020	1/16" thick x 10-1/2" x 19"	\$14.74

NUMBER	SIZE	EACH
A46911-1120	1/8" thick x 10-1/2" x 19"	\$19.80

Etching Press Bench

Made of sturdily constructed of steel, these benches are pre-drilled for mounting any 906 Press, regardless of date of manufacture. Convenient storage shelf below. Stands 29"H x 15-1/2"W x 50"L.

NUMBER	EACH
A45020-0000	\$288.82



Blick' 906 Press

Ideal for home studios, art fairs, and schools.

- Economically priced, gear-driven press.
- Ideal for etching, drypoint, engraving, collagraph, unmounted or mounted linoleum block prints, and paper plate lithographs.
- Lightweight and portable. Removal of the bed plate makes carrying the press easier.
- Steel or phenolic bed plates sold separately.
- Purchase of a catcher blanket and pusher blanket are recommended.

NUMBER	DESCRIPTION	WEIGHT	EACH
A45013-0000	Press Only	48 lb	\$1401.00

Bed Plates for the 906 Press

NUMBER	DESCRIPTION	WEIGHT	EACH
A45013-1126	26" Steel Bed Plate & Blanket (660 mm)	25 lb	\$217.75
A45013-1136	36" Steel Bed Plate & Blanket (915 mm)	35 lb	292.45
A45013-1026	26" Phenolic Bed Plate & Blanket (660 mm)	6 lb	189.90
A45013-1036	36" Phenolic Bed Plate & Blanket (915 mm)	8 lb	227.88

Wool Blankets for the 906 Press

Made of fine-quality, dense wool felt.

NUMBER	COLOR	SIZE	EACH
A46901-2512	Gray	1/4" thick x 12" x 26"	\$26.96
A46901-1042	White	1/4" thick x 12" x 26"	26.11
A46901-2513	Gray	1/4" thick x 12" x 36"	49.32
A46901-1043	White	1/4" thick x 12" x 36"	49.32

NUMBER	SIZE	EACH
A46901-1226	1/16" thick x 12" x 26"	\$20.73
A46901-1236	1/16" thick x 12" x 36"	26.99

NUMBER	SIZE	EACH
A46901-1026	1/8" thick x 12" x 26"	\$26.99
A46901-1036	1/8" thick x 12" x 36"	42.49



Blick' 906 Model II Press

Excellent for the school or studio!

- Incorporates many features of larger presses.
- Gear-driven for easy pulling of etchings, drypoints, engravings, collagraphs, unmounted or mounted linoleum block prints, and paper plate lithographs.
- Bed plate is 3/4" wider than the original 906 Press.
- Steel or phenolic bed plates sold separately.
- Purchase of a catcher blanket and pusher blanket are recommended.

Does not qualify for free shipping offer. See shipping charge exceptions on page 648 for details.

NUMBER	DESCRIPTION	WEIGHT	EACH
A45033-1010	Press only	86 lb	\$2058.00

Bed Plates for the 906 Model II Press

NUMBER	DESCRIPTION	WEIGHT	EACH
A45033-1050	36" Steel Bed Plate & 36" Cushion Blanket	36 lb	\$182.08
A45033-1020	26" Phenolic Bed Plate & 26" Cushion Blanket	12 lb	147.07
A45033-1030	36" Phenolic Bed Plate & 36" Cushion Blanket	16 lb	196.27

Wool Blankets for the 906 Model II Press

Made of fine-quality, dense wool felt.

NUMBER	COLOR	SIZE	EACH
A46911-1170	Gray	1/4" thick x 12" x 26"	\$28.66

NUMBER	SIZE	EACH
A46911-1130	1/16" thick x 12" x 26"	\$21.67
A46911-1140	1/16" thick x 12" x 36"	28.29

NUMBER	SIZE	EACH
A46911-1040	1/8" thick x 12" x 26"	\$28.30
A46911-1050	1/8" thick x 12" x 36"	44.55

906 Model II Press Bench

Constructed of sturdy tubular steel, this bench is pre-drilled for mounting the 906 Model II press only. Stands 16"W x 29-1/2"L x 34-1/4"H (working height with press). Weighs 15 lb.

NUMBER	EACH
A45032-1001	\$514.00

for every application



Blick' 999 Model II Press

Outstanding features at an affordable price!

- Incorporates many features of the larger Blick Master Etch Model II.
- Built for studio or classroom use.
- Gear-driven for easy pulling of etchings, drypoints, engravings, collagraphs, linoleum block prints, and paper plate lithographs.
- Calibrated pressure adjusters allow visibility of pressure being applied.
- Phenolic bedplate is a lightweight, non-porous, non-compressible, rustproof material.
- Includes a 1/4" thick gray cushion blanket.
- Purchase of a catcher blanket and pusher blanket are recommended. Truck Shipment. See page 648 for details.

NUMBER	DESCRIPTION	WEIGHT	EACH
A45031-1001	Press only	115 lb	\$2183.00

Wool Blankets for the 999 Model II Press

Made of fine-quality, dense wool felt.

NUMBER	COLOR	SIZE	EACH
A46911-1190	Gray	1/4" thick x 18" x 36"	\$60.83
A46911-1080	White	1/4" thick x 18" x 36"	60.78

NUMBER	SIZE	EACH
A46911-1150	1/16" thick x 18" x 36"	\$41.68

NUMBER	SIZE	EACH
A46911-1010	1/8" thick x 18" x 36"	\$53.84

999 Model II Press Bench

Constructed of sturdy tubular steel, this bench is pre-drilled for mounting the 999 Model II Press only. Stands 34-1/4"H x 21-1/2"W x 30"L (working height with press). Weighs 15 lb.

NUMBER	EACH
A45030-1001	\$683.00



Blick' Master Etch Model II Press

- A precision tool of intermediate size.
- Durable enough for classroom use yet versatile enough for the studio.
- Made of lightweight, contemporary materials with solid steel rolls.
- Weighs 268 lb.
- Two-year Blick warranty. Truck Shipment. See page 648 for details.

NUMBER	EACH
A45028-1001	\$5263.00

Wool Blankets for the Master Etch Model II Press

Made of fine-quality, dense wool felt.

NUMBER	COLOR	SIZE	EACH
A46911-1090	White	1/4" thick x 22-1/2" x 36"	\$70.99
A46911-1200	Gray	1/4" thick x 22-1/2" x 36"	63.21

NUMBER	SIZE	EACH
A46911-1160	1/16" thick x 22-1/2" x 36"	\$56.28

NUMBER	DESCRIPTION	EACH
A46911-1030	1/8" thick x 22-1/2" x 36"	\$60.83

Master Etch Model II Press Bench

Constructed of sturdy tubular steel, this bench is pre-drilled for mounting the Master Etch Model II Press. Includes four leveling feet for balance adjustment. Stands 35"H x 26"W x 33"L (working height with press). Weighs 19 lb. Truck Shipment. See page 648 for details.

NUMBER	EACH
A45034-1001	\$641.00

BLICK printing press comparison chart

ITEM	HANDLE	UPPER ROLLER SIZE	LOWER ROLLER SIZE	BED SIZE CHOICES	MAXIMUM PRINT SIZE	WARRANTY
Blick Econo Etch Model II	Two-point	3"D x 10-3/4"W lathe-turned solid steel	1-1/2"D x 10-3/4"W, lathe-turned solid steel	11-3/4"W x 19-3/4"L	9-1/2"W x 18"L	Two-Year Blick Warranty
Blick 906 Etching Press	Three-point	4"D, lathe-turned steel	2"D, lathe-turned steel	12-3/4"W x 26"L or 12-3/4"W x 36"L	12"W x 24"L or 12"W x 34"L	Two-Year Blick Warranty
Blick 906 Model II	Three-point	4-1/2"D x 13"W, lathe-turned steel	2"D x 13"W, lathe-turned solid steel	13-3/4"W x 26"L or 13-3/4"W x 36"L	12"W x 25"L or 12"W x 35"L	Two-Year Blick Warranty
Blick 999 Model II	Three-point	4-1/2"D x 19"W, finely machined solid steel	2"D x 19"W, lathe-turned solid steel	19-5/8"W x 36"L	17"W x 35"L	Two-Year Blick Warranty
Blick Master Etch Model II	Four-point	4-1/4"D x 22-3/4"W, spring-assisted, solid steel	3"D x 22-3/4"W, lathe-turned solid steel	23-5/8"W x 36"L	22"W x 35"L	Two-Year Blick Warranty



We recommend that you use three blankets — a cushion, a pusher, and a catcher — to equalize the pressure and lessen the strain on the upper roll shaft of your press. If you are purchasing a Blick press, the cushion blanket is included. You will need to purchase a catcher and a pusher. The catcher blanket should be placed directly on top of your damp printing paper to catch the sizing from the paper, the cushion blanket on top of the catcher, and the pusher on the very top. The catcher blanket should be washed regularly so it doesn't become stiff from the paper's sizing residue.

Got a question about a product?
Our experts have the answer!
Three ways to connect —
Live Chat at DickBlick.com, call
800.933.2542, or email info@DickBlick.com.



Copernicus® Wall-Mounted Drying Rack

Durable coated metal shelves let paintings, murals, and mosaics dry flat so kids have lots of space to dry their artwork. Compact 20-shelf rack mounts on the wall. 33-1/4"H x 20"W x 16"D. Assembly required. FOB Factory. See page 648 for details.

NUMBER	EACH
AF51329-1030	\$182.99



Copernicus® Double-Sided Drying Rack

High-volume, coated steel rack sits nicely on most tabletops and holds up to 40 paintings (20 on each side). Rounded corners make it safer for young kids. Shelves can be raised and lowered. Minimal assembly. 26-1/4"H x 20"W x 32"D. FOB Factory. See page 648 for details.

NUMBER	EACH
AF51329-1020	\$275.99



Copernicus® Spring-Loaded Drying Rack

Each shelf contains two springs, so kids can insert and remove their paintings with ease. Metal frame has a tough, coated finish and rounded corners for safety. Holds up to 20 paintings and includes four casters for mobility. 33-1/2"H x 26-1/2"W x 25"D. Minimal assembly. FOB Factory. See page 648 for details.

NUMBER	EACH
AF51329-1010	\$264.99

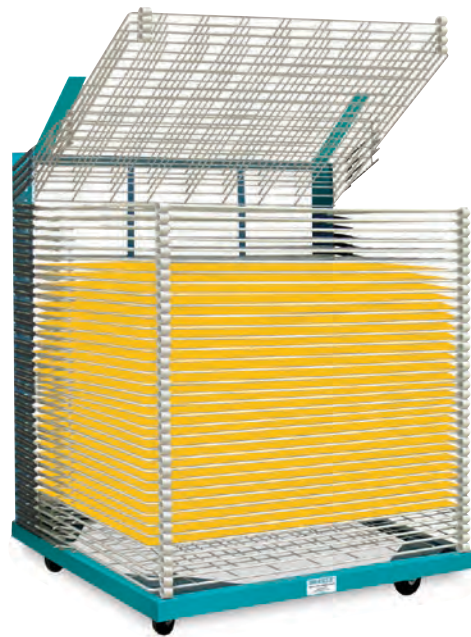

AWT® "Rack It" Drying Racks

These drying racks feature an all-steel structural framework with an enameled finish. Spring-tension arms hold the shelves in any convenient position. Quality designed outside bumpers (two per shelf) permit the use of the entire shelf for drying. Assembly required. For more sizes, visit DickBlick.com. Truck Shipment and FOB Factory. See page 648 for details.

NUMBER	DESCRIPTION	SIZE	EACH
AF51307-1006	Rack It I with 40 Shelves	30" x 46" Shelves	\$1639.00
AF51309-4015	Rack It II with 40 Shelves	26" x 36" Shelves	1550.00
AF51309-1006	Rack it II with 40 Shelves	31" x 48" Shelves	1995.00
AF51309-5015	Rack It II with 50 Shelves	26" x 36" Shelves	1835.00

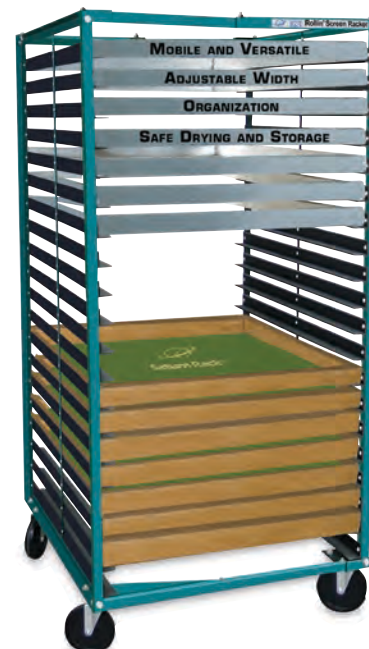

AWT® Rollin' Screen Racker™

A safe, convenient place for drying and storing screens. Four locking casters add mobility and stability. The rack's deep shelves adjust from 15-1/2" to 46-1/2" wide to easily accommodate all screen frames. The heavy-duty PVC angle shelves support heavy loads and won't scratch. A great storage solution when space is limited. Assembly required. 25-Shelf Rack requires Truck Shipment. FOB Factory. See page 648 for details.

NUMBER	DESCRIPTION	EACH
AF43000-1010	20-Shelf Rack	\$637.00
AF43000-1020	25-Shelf Rack	825.00

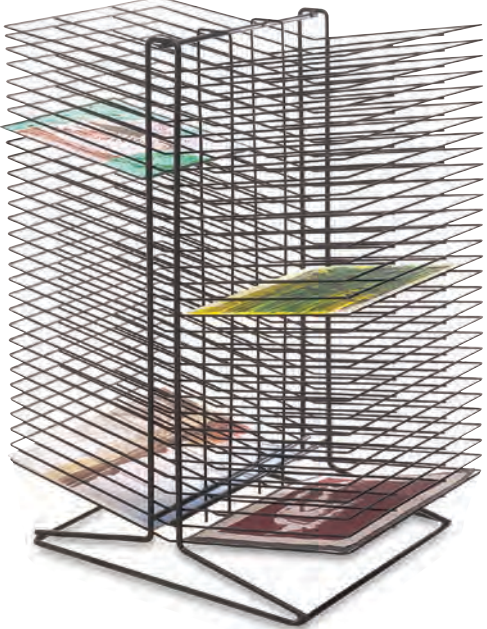

Back-To-Back Table Rack

Specifically designed to meet the requirements of today's art classrooms, this 60-shelf rack features sturdy construction with top-grade materials. It is easy to handle for tabletop or floor use. Shelves measure 12" x 16". Assembly is required. FOB Factory. See page 648 for details.

NUMBER	EACH
AF51303-1006	\$265.99

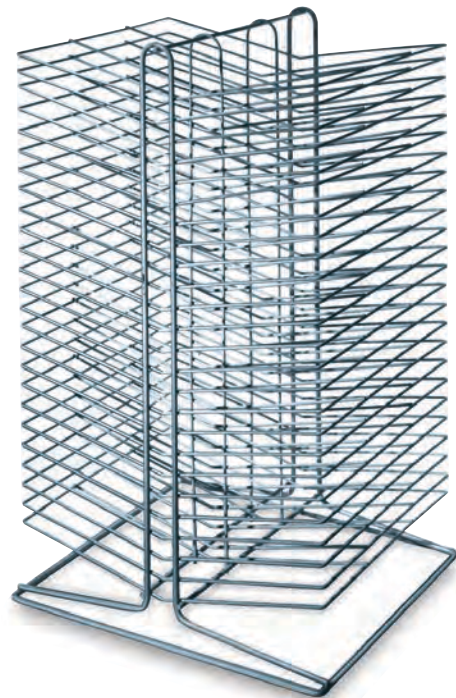

AWT® Table Rack

This multi-purpose table rack can be used as a drying or storage rack in art classes, print or sign shops, or home hobby areas. It's made of all-steel wire and welded for strength, with a durable, powder-coated finish. Comes fully assembled with 50 rigid shelves (25 on each side), each measuring 10" x 18". Mesh size is 6" x 10". Overall size is 32"H x 19-1/2"W x 22"D. Can be used on a tabletop, counter, or rolling cart. Weighs 33 lb. FOB Factory. See page 648 for details.

NUMBER	EACH
AF51308-1006	\$311.00

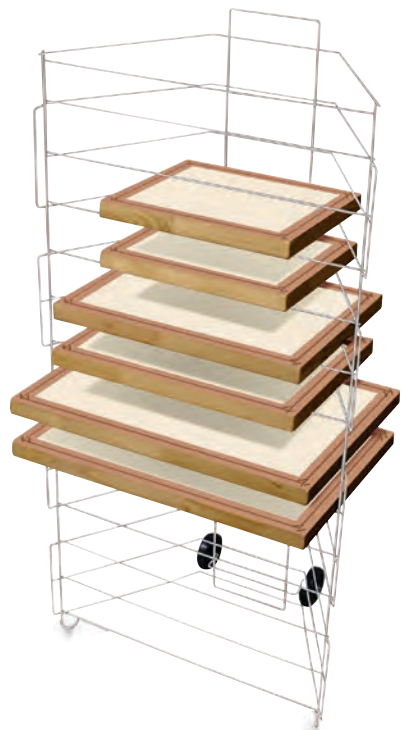

AWT® Versa-Rack™ Drying and Storage Racks

Lightweight and portable, with sturdy, all-metal construction and powder-coated, rust-resistant shelves. Ideal for classrooms, studios, print shops, and homes — or anywhere space is limited. Both the 8-shelf and 13-shelf racks hold a variety of rigid or semi-rigid items, including construction paper, posterboard, heavy felt, screen print frames, stretched canvases, boards, and other objects measuring up to 12" x 18" or larger, with a 3" clearance. Perfect for air-drying or storage.

NUMBER	DESCRIPTION	EACH
A51339-1008	8 Shelves	\$114.46
A51339-1013	13 Shelves	138.47



AWT® Saturn Tensor-18™ Drying Rack

Improved design includes rust-resistant, powder-coated shelves for smoother operation, thicker gauge steel wire shelves, a 6" x 6" mesh size to accommodate smaller pieces, a retaining strip to keep shelves in place without hindering movement, and larger bumpers for more shelf support. This versatile rack features deep, 18" x 24" trays and solid steel construction with two rubber tray bumpers for sufficient airflow between shelves. These rubber bumpers not only hold more weight and larger sheets but also help maintain stability and proper shelf spacing. Also equipped with TrayLock, a positive locking mechanism that holds the racks firmly in place after they are lifted up to adjust or move substrates. Swiveling casters for mobility. Truck Shipment. FOB Factory. See page 648 for details.

NUMBER	DESCRIPTION	SIZE	EACH
AF51342-1040	40-Shelf Rack	45-1/2"H x 25-1/2"W x 25"D	\$818.00
AF51342-1080	80-Shelf Rack	45-1/2"H x 39-1/4"W x 25"D	1721.00
AF51342-1100	100-Shelf Rack	54-1/2"H x 39-1/4"W x 25"D	3563.00



AWT® Dry-It™ Screen Drying Cabinet

Increase productivity and decrease downtime by drying out screen printing frames in this portable drying unit. Use it for many other low-temperature drying applications as well. It improves screen quality by drying screens quickly and evenly and also eliminates dust that causes pinholes and exposure flaws. 10 shelves. Casters for mobility. 110V at 13.5A, 1 Phase, 60 Hz. Adjusts to 120°F (49°C). Truck Shipment and FOB Factory. See page 648 for details.

NUMBER	EACH
AF43020-1048	\$3721.00



A AWT Portable Drying Racks

These durable, steel drying racks include space bumpers that maintain parallel spacing in up and down positions. They maintain their up-angle pivotal position without the use of springs. Units rest on ball-bearing swivel casters for easy portability. Assembly required. For dimensions and more sizes, visit DickBlick.com. This product has an extended lead time for delivery. Truck Shipment. FOB Factory. See page 648 for details.

NUMBER	DESCRIPTION	SIZE	EACH
AF51310-1009	40-Shelf Rack	18" x 24" Shelves	\$768.00
AF51310-1109	50-Shelf Rack	18" x 24" Shelves	989.00
AF51309-1104	40-Shelf Rack	20" x 26" Shelves	878.00
AF51309-1105	50-Shelf Rack	20" x 26" Shelves	988.00

Set of 40 Extra Bumpers — For additional shelf stability for heavy items.

NUMBER	EACH
A51310-0000	\$73.47

B Gran Adell Easy Ship Drying Racks

An all-steel, 40-shelf rack with a heavy-duty angle base, exclusive tray-lock system for supporting trays in the up position, and two rubber spacers on each tray. Very sturdy and maintenance-free. 18" x 24" shelf. Mesh size is 6" x 8", with 1" spacing between trays. Overall measurements: 45-1/2"H x 25-1/2"W x 25"D. Assembly required. FOB Factory. See page 648 for details.

NUMBER	EACH
AF51311-1000	\$846.00

Double-Sided Easy Ship Drying Rack — All the features and double the capacity of the original Easy Ship rack. It measures 54" deep overall, and provides a total of 80 trays. FOB Factory. See page 648 for details.

NUMBER	EACH
AF51311-0000	\$1548.00

C Gran Adell Junior Size Multi-Racks

Perfect for small sheets, standard-size posters, and watercolor sheets. Strong, durable, all-steel construction with a spring suspension system, strong back frames, and casters for easy mobility. 22" x 32" trays with 4" x 4-1/2" mesh openings and 1-1/8" spacing. Measures 28"W x 32-1/2"D overall. Assembly required. Truck Shipment and FOB Factory. See page 648 for details.

NUMBER	EACH
40-Tray Rack — 52" high with trays down, 64" high with trays up. 238 lb.	
AF51305-1004	\$1942.00

50-Tray Rack — 67" high with trays down, 79" high with trays up. 276 lb. Truck Shipment and FOB Factory. See page 648 for details.

NUMBER	EACH
AF51305-1104	\$2144.00

D Gran Adell Metal Drying Racks

These flip racks have 50 non-warping metal trays with patented, non-locking rubber feet. Trays rest flat when down, nest together when up to permit wider opening, and they won't tangle. Trays are spaced 1-1/8" apart. Easy loading from bottom to top. Adjustable steel springs permit tension setting as desired, and hold trays up when loading or unloading. Sheets can overhang if retained 6" from the back. Racks have reinforced framework and move easily on ball-bearing casters. Height is 62" with trays down, 86" with trays up. Strong enough for glass, lightweight metal, or plastic sheeting. Assembly required. Truck Shipment and FOB Factory. See page 648 for details.

Rack with 32" x 48" Trays — Mesh opening size is 4" x 4-1/2"; floor space is 37" x 48-5/8". Weighs 457 lb.

NUMBER	EACH
AF51315-1007	\$3320.00

Rack with 43" x 33" Trays — Mesh opening size is 5-1/2" x 8-1/2"; floor space is 33-5/8" x 48". Weighs 400 lb. Truck Shipment and FOB Factory. See page 648 for details.

NUMBER	EACH
AF51315-1006	\$2972.00



Blick StakRak

This ingenious system of interlocking racks can be mounted to the wall. Or attach two units back-to-back and use as a table rack. Combine four units with a caster package to create a mobile floor unit. Each rack includes 25 shelves that are 12" x 18-1/2". Black powder-coated finish. Overall dimensions: 30"H x 22"W x 17"L.

NUMBER	EACH
A51324-0000	\$219.09

Set of 4 Casters — Black plastic 3" casters (two locking, two non-locking).

NUMBER	EACH
A51324-1001	\$17.35



Rollaway Rackaway™

Made of two Original Rackaways, mounted back-to-back, on a carriage that rolls easily on 2" casters. Casters may be removed for use as a tabletop unit. Each shelf has wire cross-pieces forming a 4" x 8" grid. Dimensions: 46"H x 14"W x 18"D when all 60 shelves are in storage position; 46"H x 28-1/2"W x 18"D when in use. Shelf size 12" x 16". Ships fully assembled. Weighs 50 lb. FOB Factory. See page 648 for details.

NUMBER	EACH
AF51301-1006	\$470.00



The Original Rackaway™

Built to last a lifetime, the Rackaway is constructed of top-grade materials and assembled with the highest quality standards. Strong, welded construction with a black, baked-on epoxy finish. Each shelf is 12" x 16" and has wire cross-pieces forming a 4" x 8" grid. Comes with brackets for mounting on a door or wall. When not in use, its 30 shelves can be folded to take up only 4-1/2" x 16" x 42" space. Two racks can be bolted together (hardware included), providing 60 shelves in a vertical column. Weighs 22.5 lb. Ships unassembled. FOB Factory. See page 648 for details.

NUMBER	EACH
AF51302-1006	\$185.99



AWT Single-Side Drying Rack

Thirty large shelves with wire supports provide enough drying space for the paintings of an entire class, or a series of prints. Strong, welded construction with powder-coated finish to resist rust and solvents. This rack can sit either on a table or on the floor, and it uses space effectively when placed against a wall. 37-1/2"H x 19-1/2"W x 19-1/2"D. Shelf size is 12" x 18" with 6" x 10" mesh. Weighs 26 lb. Ships fully assembled. FOB Factory. See page 648 for details.

NUMBER	EACH
AF51312-1006	\$171.50

Wall- or Door-Mounted Drying Rack — FOB Factory. See page 648 for details.

NUMBER	EACH
AF51316-0001	\$208.53

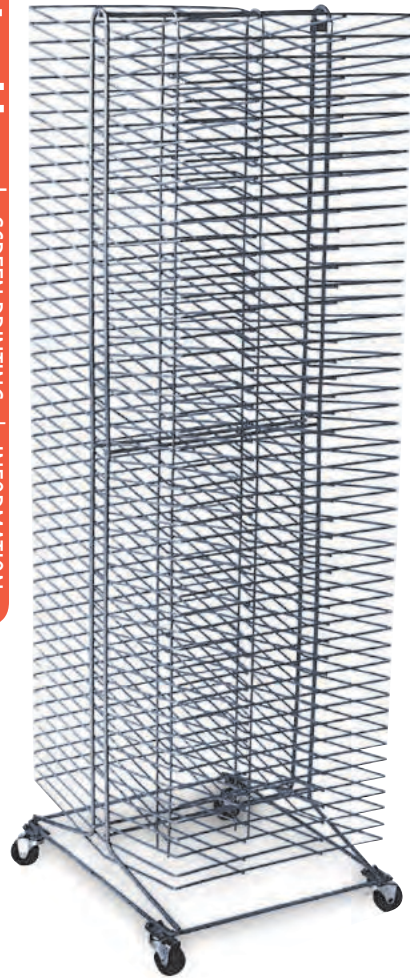

AWT 100-Shelf Portable Rack

Up to 100 sheets of paper, cardboard, or plastic can be dried or stored on this all-welded steel wire rack. It has 100 stationary shelves, 50 on each side, spaced 1" apart. Each measures 10" x 18" with a mesh size of 6" x 10". Two pre-assembled pieces stack together, mounted on 2" ball casters. Base size is 19" x 22". Gray powder-coated finish. Weighs 68 lb. This product has an extended lead time for delivery. Visit DickBlick.com for details. FOB Factory. See page 648 for details.

NUMBER	EACH
AF51304-1006	\$495.00

screen printing tips

basic steps in screen printing

- Create a design to be printed.
- Assemble the screen frame (or use a pre-assembled frame).
- Prepare the screen by degreasing and abrading the fabric mesh.
- Apply the design to the screen in one of several ways:
 - A. Non-photographic methods:**
 - Cut or tear a paper stencil. (An elementary classroom method for very short runs.)
 - Paint on the screen using block-out, Speedball Drawing Fluid/Screen Filler, or liquid tusche, tusche pencils, or tusche crayons. This is a freestyle, painterly method.
 - Cut a stencil out of film and adhere it to the screen, following manufacturer's instructions. This hand-cut method is for bold, hard-edge designs.
 - B. Photographic methods:**
 - Direct Method:**
 - Start with a film positive of your design.
 - Apply photo-sensitive direct film or direct emulsion to your prepared screen. Follow manufacturer's instructions.
 - Expose the film positive in contact with the screen to a proper light source.
 - Indirect Method:**
 - Start with a film positive (same as above).
 - Expose the film positive in contact with the photosensitive indirect screen printing film, using a proper light source.
 - Use the prescribed developer (A & B developer or water, depending on the film) to wash out the positive parts of your design, leaving the film open in those areas for printing ink to pass through.
 - While the film is still wet, apply it to your prepared screen according to instructions.
- Finish the screen:
 - Apply liquid block-out or tape to all areas outside of the film edges that you do not want to print, using a brush, flat plastic scraper, or piece of cardboard. Also fill pin holes, if any, with a small brush.
 - Use water-moistened gummed tape or polyester film tape to seal the edges of the screen frame to prevent ink from getting into hard-to-clean areas.
- Print the design on the material you have chosen, using a squeegee to force the ink through the open areas of your screen.
- Dry the prints or garments, heat setting them if necessary.
- Clean the ink from the screen using the proper solvent.
- Reclaim the screen for future use by removing the stencil. Use appropriate removers.

For more tips and information about screen printing, visit DickBlick.com.

how to determine which process to use

There are many questions to be asked about the screen printing process. Unfortunately, concrete answers are not always available. It is important to gather as much information as possible, then draw your own conclusions based on what works for you! (See page 365 for several helpful books.) You might start by asking yourself these questions:

- What am I going to print (T-shirts or other garments, posters, outdoor signs, etc.)? The item to be printed will determine the type of ink you will need, and the ink will dictate which process and film or emulsion to use.
- How long do the items need to last? An outdoor sign may need to last many years, while an indoor poster may be temporary. A T-shirt may be expected to be worn once for an event, while a sweatshirt or jacket must be able to withstand many launderings. You do not have to use expensive materials if the project doesn't require them.
- Do I prefer to print with waterbased inks or solvent-based inks if both will work?
- Is my design simple enough for the hand-cut method or does it require the photo process?
- How many colors does my design have? A simple image with one or two colors can be done with the hand-cut film method using just one screen. As long as the different colored areas do not touch or overlap, the second colored area can be covered up with masking tape on the back of the screen while the first color is being printed. A half-tone picture, four-color process photographic image, or design with two or more colors overlapping and butting up will require the photo screen process and a separate screen for each color. The colors will also have to be registered; that is, the shirt or poster will have to be in the exact same place each time a new color is printed. (Printing machines for this purpose are very helpful.)

follow these guidelines

T-Shirts and other cotton/blend garments, posters, and fine art prints — Nazdar 5500 Series solvent-based inks and Speedball Permanent Acrylic waterbased inks are the highest quality. The less expensive Speedball Water-Soluble inks are good for temporary indoor signage. Blick Textile Inks may also be used. Posters usually have lots of lettering, and therefore are too difficult for hand-cut film. Fine art prints often use the freestyle tusche method, but hand-cut film and photographic methods are also popular.

Outdoor signs — Nazdar 9700 Series and Nazdar 59000 Series solvent-based inks (available on our website) have excellent longevity in all kinds of weather. If the lettering is large and simple, hand-cut film may be used. For more complex or multi-color designs, use photo-sensitive direct emulsion, Ulanox CDF4/LX film, or indirect film.

Vinyl surfaces (signs, tarps, covers, banners, anything made of vinyl) — Nazdar GV Series (available on our website) solvent-based ink (or equivalent brand) is absolutely necessary. Nothing else will adhere. Use watersoluble hand-cut film, photo-sensitive Ulanox CDF4/LX direct film, or indirect films, except Ulanolux UP3.



Jacquard Screen Printing Kit

Make your own art prints, cards, and wearable art! Ideal for paper, fabric, vinyl, plastic, or leather. Professional-quality watersoluble inks are easy to work with and hold up to washing and dry cleaning. For kit contents, visit DickBlick.com.

NUMBER	EACH	6/EA
A40312-1009	\$106.29	\$95.65

Set of 6

NUMBER	EACH	3/EA
A40312-1029	\$123.99	\$111.61

Extender — Make Jacquard Screen Printing Inks more transparent without sacrificing the ink's texture or consistency.

NUMBER	SIZE	EACH	6/EA
A40312-1004	4 oz (120 ml)	\$7.81	\$7.03
A40312-1006	16 oz (473 ml)	21.50	19.34



Jacquard Versatex Screen Printing Ink

Versatile, ready-to-use inks are ideal for silk screening, stenciling, and block printing. Colors are intermixable and can be thinned with water. Though heavily pigmented, Versatex will not change the texture or softness of fabric, and will not wrinkle or bleed on paper. These semi-transparent inks are most luminous on light-colored fabrics. Use clear Extender (available online) for transparent overlays. Colors can be assorted for quantity pricing.

COLOR	4 OZ (118 ML)	EACH	5/EA	16 OZ (473 ML)	EACH	4/EA	GALLON (3.78 LITER)	EACH	4/EA
Black	A01205-2004	\$7.50	\$6.75	A01205-2006	\$17.13	\$15.42	A01205-2029	\$87.19	\$78.46
Blue	A01205-5004	7.50	6.75	A01205-5006	17.13	15.42	A01205-5009	87.19	78.46
Bright Red	A01205-3074	7.50	6.75	A01205-3076	17.13	15.42	A01205-3079	87.19	78.46
Bronze	A01205-8154	7.93	7.13	A01205-8156	19.31	17.38	A01205-8159	111.97	100.78
Brown	A01205-8004	7.50	6.75	A01205-8006	17.13	15.42	A01205-8009	87.19	78.46
Copper	A01205-8124	7.93	7.13	A01205-8126	19.31	17.38	A01205-8129	111.97	100.78
Fluorescent Blue	A01205-5244	8.58	7.72	A01205-5246	21.80	19.63	A01205-5249	127.04	114.34
Fluorescent Yellow	A01205-4224	8.58	7.72	A01205-4226	21.80	19.63	A01205-4229	127.04	114.34
Gold	A01205-9004	7.93	7.13	A01205-9006	19.31	17.38	A01205-9009	111.97	100.78
Gold Yellow	A01205-4064	7.50	6.75	A01205-4066	17.13	15.42	A01205-4069	87.19	78.46
Green	A01205-7004	7.50	6.75	A01205-7006	17.13	15.42	A01205-7009	87.19	78.46
Hot Pink	A01205-3294	8.58	7.72	A01205-3296	21.80	19.63	A01205-3299	127.04	114.34
Magenta	A01205-3044	7.50	6.75	A01205-3046	17.13	15.42	A01205-3049	87.19	78.46
Navy Blue	A01205-5044	7.50	6.75	A01205-5046	17.13	15.42	A01205-5049	87.19	78.46
Ochre	A01205-4044	7.50	6.75	A01205-4046	17.13	15.42	A01205-4049	87.19	78.46
Opaque White	A01205-1184	8.58	7.72	A01205-1186	22.56	20.31	A01205-1189	132.05	118.85
Orange	A01205-4504	7.50	6.75	A01205-4506	17.13	15.42	A01205-4509	87.19	78.46
Pearl	A01205-1094	7.96	7.16	A01205-1096	19.03	17.13	A01205-1099	111.79	100.59
Red	A01205-3004	7.50	6.75	A01205-3006	17.13	15.42	A01205-3009	87.19	78.46
Royal Blue	A01205-5054	7.50	6.75	A01205-5056	17.13	15.42	A01205-5059	87.19	78.46
Rubine	A01205-3744	7.50	6.75	A01205-3746	17.13	15.42	A01205-3749	87.19	78.46
Scarlet	A01205-3084	7.50	6.75	A01205-3086	17.13	15.42	A01205-3089	87.19	78.46
Silver Lace	A01205-9334	7.93	7.13	A01205-9336	19.31	17.38	A01205-9339	111.97	100.78
Sky Blue	A01205-5074	7.50	6.75	A01205-5076	17.13	15.42	A01205-5079	87.19	78.46
Super Opaque White	A01205-1084	9.76	8.78	A01205-1086	24.17	21.76	A01205-1089	153.50	138.15
Turquoise	A01205-5114	7.50	6.75	A01205-5116	17.13	15.42	A01205-5119	87.19	78.46
Ultramarine Blue	A01205-5134	7.50	6.75	A01205-5136	17.13	15.42	A01205-5139	87.19	78.46
Umber	A01205-8534	7.50	6.75	A01205-8536	17.13	15.42	A01205-8539	87.19	78.46
Violet	A01205-6504	7.50	6.75	A01205-6506	17.13	15.42	A01205-6509	87.19	78.46
White	A01205-1014	7.50	6.75	A01205-1016	17.13	15.42	A01205-1018	87.19	78.46
Yellow	A01205-4004	7.50	6.75	A01205-4006	17.13	15.42	A01205-4009	87.19	78.46
Yellow Green	A01205-7344	7.50	6.75	A01205-7346	17.13	15.42	A01205-7349	87.19	78.46

JACQUARD

Jacquard Screen Printing Ink

These professional, permanent screen printing inks can be used on a wide variety of porous and non-porous surfaces, including vinyl, metal, clay, leather, and natural and synthetic fabric and paper. Ideal for commercial applications, they have a soft hand and a long open time, giving the user more time to work with individual colors. They're extremely lightweight with great resolution, and their opacity is unparalleled. They won't wrinkle paper when screening art prints, and they're washable and dry-cleanable on fabrics after heat-setting or air-curing for at least 72 hours. Soap-and-water cleanup. Colors can be assorted for quantity pricing.

COLOR	4 OZ (118 ML) JARS	16 OZ (473 ML) JARS
Black	A40312-2024	A40312-2026
Blue	A40312-5004	A40312-5006
Bright Red	A40312-3074	A40312-3076
Brown	A40312-8004	A40312-8006
Copper	A40312-9504	A40312-9506
Gold	A40312-9014	A40312-9016
Golden Yellow	A40312-4094	A40312-4096
Green	A40312-7004	A40312-7006
Magenta	A40312-3044	A40312-3046
Navy	A40312-5044	A40312-5046
Ochre	A40312-4044	A40312-4046
Orange	A40312-4514	A40312-4516
Red	A40312-3014	A40312-3016
Royal Blue	A40312-5054	A40312-5056
Rubine	A40312-3744	A40312-3746
Scarlet	A40312-3084	A40312-3086
Silver	A40312-9334	A40312-9336
Sky Blue	A40312-5014	A40312-5016
Solar Gold	A40312-9114	A40312-9116
Super Opaque White	A40312-1034	A40312-1036
Turquoise	A40312-5114	A40312-5116
Violet	A40312-6514	A40312-6516
White	A40312-1024	A40312-1026
Yellow	A40312-4014	A40312-4016
Yellow Green	A40312-4754	A40312-4756
	EACH \$7.81	EACH \$21.50
	6/EA 7.03	6/EA 19.34

Opaque Colors

COLOR	4 OZ (118 ML) JARS	16 OZ (473 ML) JARS
Blue	A40312-5024	A40312-5026
Brown	A40312-8014	A40312-8016
Green	A40312-7014	A40312-7016
Navy	A40312-5034	A40312-5036
Ochre	A40312-4044	A40312-4046
Orange	A40312-4524	A40312-4526
Red	A40312-3024	A40312-3026
Rubine	A40312-3744	A40312-3746
Violet	A40312-6524	A40312-6526
Yellow	A40312-4024	A40312-4026
	EACH \$7.81	EACH \$21.50
	6/EA 7.03	6/EA 19.34

Process Colors

COLOR	4 OZ (118 ML) JARS	16 OZ (473 ML) JARS
Cyan	A40312-5514	A40312-5516
Magenta	A40312-3714	A40312-3716
Yellow	A40312-4404	A40312-4406
	EACH \$7.81	EACH \$21.50
	6/EA 7.03	6/EA 19.34



new!

NEW! Speedball® Speed Screen

Perfect for novices and anyone looking to create photo emulsion stencils in minutes, the Speedball Speed Screens Kit includes everything needed to create permanent photographic stencils on a variety of surfaces—no mixing, coating, or drying required!

NUMBER	EACH
A45220-1001	\$86.89



new!

NEW! Speedball® Speed Screen 3pk

Contains three ready-to-use mesh Speed Screens.

NUMBER	EACH
A45220-1003	\$34.06



new!

NEW! Speedball® Beginner Craft Vinyl Kit

Combine vinyl crafting and screen printing with the Speedball Beginner Craft Vinyl Kit! This all-in-one kit is perfect for customizing apparel, home décor, and more. The step-by-step instructions make it easy to create unique, personalized art. For complete set contents, visit DickBlick.com.

NUMBER	EACH
A37713-1001	\$43.99



Speedball® Permanent Acrylic Screen Printing Ink

This is waterbased, non-toxic, non-clogging, highly opaque ink for signs, posters, and fine art prints on paper, posterboard, and wood. The flexible acrylic colors air dry quickly. Wash screen with soap and water immediately after use. Do not use on metal, plastic, or fabrics that are to be laundered. Colors can be assorted for quantity pricing.

8 oz (237 ml) Jar				
NUMBER	COLOR	EACH	12/EA	
A43229-2025	Black	\$8.99	\$8.11	
A43229-8005	Brown	8.99	8.11	
A43229-5035	Dark Blue	8.99	8.11	
A43229-3035	Dark Red	8.99	8.11	
A43229-7055	Emerald	8.99	8.11	
A43229-3125	Fire Red	8.99	8.11	
A43229-9015	Gold	8.99	8.11	
A43229-3715	Medium Red	8.99	8.11	
A43229-4025	Medium Yellow	8.99	8.11	
A43229-4515	Orange	8.99	8.11	
A43229-5215	Peacock Blue	8.99	8.11	
A43229-4175	Primrose Yellow	8.99	8.11	
A43229-5515	Process Cyan	8.99	8.11	
A43229-3725	Process Magenta	8.99	8.11	
A43229-4405	Process Yellow	8.99	8.11	
A43229-9335	Silver	8.99	8.11	
A43229-5135	Ultra Blue	8.99	8.11	
A43229-6515	Violet	8.99	8.11	
A43229-1025	White	8.99	8.11	



Daler-Rowney® System3 Acrylics Screen Printing Essentials

Use with System 3 Acrylics for a safe, solvent-free alternative to traditional printmaking. The acrylics (see page 41) and mediums clean up with water.

NUMBER	DESCRIPTION	EACH	6/EA	
A47109-2075	Screen Printing Drawing Fluid, 2.5 oz (75 ml)	\$7.26	\$6.53	
A47109-3005	Acrylic Printing Medium, 1.32 Gallon (5 Liter)	102.61	92.36	

Quart (946 ml) Jar				
NUMBER	COLOR	EACH	12/EA	
A43217-2007	Black	\$26.20	\$23.58	
A43217-8007	Brown	26.20	23.58	
A43217-5037	Dark Blue	26.20	23.58	
A43217-3037	Dark Red	26.20	23.58	
A43217-7057	Emerald	26.20	23.58	
A43217-3117	Fire Red	26.20	23.58	
A43217-4057	Gold	26.20	23.58	
A43217-3717	Medium Red	26.20	23.58	
A43217-4027	Medium Yellow	26.20	23.58	
A43217-5217	Peacock Blue	26.20	23.58	
A43217-5517	Process Cyan	26.20	23.58	
A43217-3727	Process Magenta	26.20	23.58	
A43217-4407	Process Yellow	26.20	23.58	
A43217-5137	Ultra Blue	26.20	23.58	
A43217-6507	Violet	26.20	23.58	
A43217-1017	White	26.20	23.58	

Extender — Quart (946 ml) Jar

NUMBER	EACH	12/EA
A43217-1007	\$23.94	\$21.55



Starter Set — Includes 4 oz (120 ml) jars of Black, Magenta, Process Cyan, and Process Yellow.

NUMBER	EACH	12/EA
A43217-0049	\$21.13	\$18.99



Speedball® Professional Poster Black Screen Printing Ink

Designed for screen printing on signs, posters, and fine art prints, this waterbased, non-toxic acrylic ink provides a deep, rich poster black finish that resists scuffing. It cleans up easily with soap and water.

NUMBER	SIZE	EACH	6/EA	
A44264-2027	32 oz	\$30.29	\$27.26	
A44264-2029	128 oz	100.23	90.21	



Speedball® Scoop Coater

Extruded from T6 aluminum, Speedball Scoop Coaters have a sharp edge for fine mesh counts and a rounded edge for lower mesh counts. Two coating edges hold an ample amount of emulsion and sit easily on any flat surface between coating sessions. They include injection-molded end-caps and a snap-on dust shield that prevents particles from mixing with the emulsion. A generous holding depth accommodates lengthy coating sessions.

NUMBER	SIZE	EACH
A40142-1011	11"	\$29.28
A40142-1016	16"	41.32
A40142-1018	18"	45.92
A40142-1020	20"	50.51

A Speedball® Waterbased Fabric Screen Printing Ink

These vibrant colors offer great coverage, smooth workability, and a soft hand. Great for light-colored cotton, linen, blends, polyester, rayon, and other synthetic fibers (except nylon). May also be brush-applied to tennis shoes, canvas bags, and more. Permanent once heat-set. Colors can be assorted for quantity pricing.

Quart (946 ml) Jars

NUMBER	COLOR	EACH	12/EA
A43207-2007	Black	\$26.73	\$24.06
A43207-5007	Blue	26.73	24.06
A43207-8007	Brown	26.73	24.06
A43207-3297	Fluorescent Hot Pink	26.73	24.06
A43207-7237	Fluorescent Lime Green	26.73	24.06
A43207-7007	Green	26.73	24.06
A43207-4517	Orange	26.73	24.06
A43207-5217	Peacock	26.73	24.06
A43207-5517	Process Cyan	26.73	24.06
A43207-3717	Process Magenta	26.73	24.06
A43207-4407	Process Yellow	26.73	24.06
A43207-3007	Red	26.73	24.06
A43207-6507	Violet	26.73	24.06
A43207-1017	White	26.73	24.06
A43207-4007	Yellow	26.73	24.06



A Starter Set of 6 — Includes 4 oz (120 ml) jars of Black, Blue, Green, Red, White, and Yellow.

NUMBER	EACH	12/EA
A43207-0069	\$33.27	\$29.95

BLICK® fabric ink

Blick inks are made for printing on light-colored T-shirts and other cotton or cotton blend fabrics, linen, rayon, polyester, and most other synthetics except nylon. Non-toxic, non-flammable, and safe for school use, they can be screen printed or applied with a brush. After heat-setting in an oven, garments are machine washable. These inks work well on paper products, too. Clean up with soap and water. Colors can be assorted for quantity pricing.

Blick® Waterbased Acrylic Fabric Screen Printing Ink

Quart (946 ml) Plastic Jars				
NUMBER	COLOR	EACH	12/EA	
A43215-2007	Black	\$24.04	\$21.63	
A43215-5007	Blue	24.04	21.63	
A43215-5917	Blue Denim	24.04	21.63	
A43215-8007	Brown	24.04	21.63	
A43215-3147	Burgundy	24.04	21.63	
A43215-7277	Fluorescent Green	24.04	21.63	
A43215-3297	Fluorescent Hot Pink	24.04	21.63	
A43215-3717	Fluorescent Magenta	24.04	21.63	
A43215-4567	Fluorescent Orange	24.04	21.63	
A43215-7007	Green	24.04	21.63	
A43215-3047	Magenta	24.04	21.63	
A43215-4507	Orange	24.04	21.63	
A43215-5217	Peacock Blue	24.04	21.63	
A43215-5517	Process Cyan	24.04	21.63	
A43215-4407	Process Yellow	24.04	21.63	
A43215-3007	Red	24.04	21.63	
A43215-6507	Violet	24.04	21.63	
A43215-1007	White	24.04	21.63	
A43215-4007	Yellow	24.04	21.63	



B-C Speedball® Night Glo™ Fabric Screen Printing Ink

These glow-in-the-dark inks exhibit high initial brightness and residual afterglow in darkened areas. For best results, use on white or light-colored fabrics. Non-toxic. Colors can be assorted for quantity pricing.

NUMBER	COLOR	EACH	6/EA	
A43210-7005	Green	\$21.14	\$19.03	
A43210-1005	White	21.14	19.03	

C Transparent Base — Create transparent colors for fabric and acrylic inks.

NUMBER	EACH	12/EA
A43207-1007	\$18.42	\$16.59

D Speedball® Opaque Iridescent Fabric Screen Printing Ink

Brilliant iridescent ink is opaque even on dark fabrics. Non-toxic, watersoluble inks are intermixable and tint easily. Colors dry to a rich, satin texture, usually in a normal classroom teaching period. Ink can be screened or brushed onto fabric, and is permanent when heat-set. Colors can be assorted for quantity pricing.

COLOR	8 OZ (237 ML) JARS	QUART (946 ML) JARS
Amethyst	A43233-7455	A43233-7457
Black Pearl	A43233-2225	A43233-2227
Blue Topaz	A43233-5665	A43233-5667
Citrine	A43233-7915	A43233-7917
Emerald Green	A43233-7055	A43233-7057
Gold	A43233-9015	A43233-9017
Pearly White	A43233-1095	A43233-1097
Raspberry	A43233-3365	A43233-3367
Sherbet	A43233-1015	A43233-1017
Silver	A43233-9335	A43233-9337

FREE SHIPPING — Orders of \$49 or more ship free.

WARNING! Products marked with a Prop 65 symbol (■ or ▼) can expose you to chemicals, including cadmium, which are known to the State of California to cause cancer and birth defects or other reproductive harm. For more information, visit P65Warnings.ca.gov.



Permaset™ Aqua Fabric Ink

This environmentally friendly, easy-to-use ink provides long-term durability without compromising its soft handle. It's 100% solvent-free, low-odor, and waterbased, while still offering superior performance, durability, and softness. Pigments are rich in coverage and intensity, and they produce exceptional color yield. After heat-fixing, the resilient resin base holds strong during rubbing, washing, or dry cleaning on cotton, polyester, silk, and most synthetic fabrics. It is low odor and cleans up easily with water. It can also be used for block printing. Conforms to ASTM D-4236. **Colors can be assorted for quantity pricing.**

Standard Colors — 10 oz (300 ml) jars.

NUMBER	COLOR	EACH	10/EA
A43232-5013	Blue	\$17.63	\$15.87
A43232-3073	Bright Red	17.63	15.87
A43232-8033	Dark Brown	17.63	15.87
A43232-7013	Green	17.63	15.87
A43232-2043	Jet Black	17.63	15.87
A43232-5843	Junior Navy	17.63	15.87
A43232-5023	Light Blue	17.63	15.87
A43232-7813	Light Green	17.63	15.87
A43232-3813	Mid Red	17.63	15.87
A43232-4773	Mid Yellow	17.63	15.87
A43232-4513	Orange Red	17.63	15.87
A43232-6003	Purple	17.63	15.87
A43232-3173	Rose	17.63	15.87
A43232-1033	Standard White	17.63	15.87
A43232-5113	Turquoise	17.63	15.87

Glow Colors — 10 oz (300 ml) jars.

NUMBER	COLOR	EACH	10/EA
A43232-5033	Glow Blue	\$27.54	\$24.79
A43232-7033	Glow Green	27.54	24.79
A43232-3043	Glow Magenta	27.54	24.79
A43232-4523	Glow Orange	27.54	24.79
A43232-3063	Glow Pink	27.54	24.79
A43232-3013	Glow Red	27.54	24.79
A43232-6513	Glow Violet	27.54	24.79
A43232-4023	Glow Yellow	27.54	24.79

Supercolor Colors — 10 oz (300 ml) jars.

NUMBER	COLOR	EACH	10/EA
A43232-2023	Supercolor Black	\$29.30	\$26.37
A43232-4033	Supercolor Mid Yellow	30.58	27.53
A43232-3093	Supercolor Scarlet	30.58	27.53
A43232-5133	Supercolor Ultra Blue	30.58	27.53
A43232-1043	Supercolor White	30.58	27.53

Sprayway® Fast Tack 384 Super Flash Spray Adhesive

Safe for use on any fabric, this high-quality, industrial-grade spray adhesive remains tacky even when exposed repeatedly to the high temperatures required to cure plastisol inks. It won't transfer to the fabric or allow fabric to shift during the screen printing process. Hexane-free and California V.O.C. compliant.

NUMBER	SIZE	EACH	6/EA
A47178-1020	20 oz can	\$12.12	\$10.91



UNION™



A Union™ UltraSoft Plastisol Liberty Series Ink

A versatile, lead-free plastisol ink, UltraSoft is formulated for direct printing and heat-transfer manufacturing. Inks offer good coverage on light- and medium-colored garments. A new formulation helps eliminate press stoppages due to buildup on the screen backs. Contain no phthalates. **Colors can be assorted for quantity pricing.**

NUMBER	COLOR	EACH	12/EA
A43242-3737	Aurora Pink	\$29.49	\$26.55
A43242-5367	Aqua Marine	26.20	23.58
A43242-2027	Black	18.94	17.05
A43242-5907	Bright Blue	23.24	20.91
A43242-7257	Bright Green	25.20	22.68
A43242-3077	Bright Red	28.83	25.95
A43242-3707	Cardinal Red	25.55	22.99
A43242-4157	Chrome Yellow	24.89	22.39
A43242-5927	Columbia Blue	22.89	20.60
A43242-3747	Cool Pink	24.55	22.09
A43242-7737	Dark Chrome Green	25.20	22.68
A43242-8037	Dark Brown	21.25	19.13
A43242-6127	Deep Purple	26.20	23.58
A43242-1007	Extender Base	17.65	15.88
A43242-4617	Flame Orange	29.83	26.85
A43242-3847	Flesh	19.80	17.82
A43242-4097	Golden Yellow	23.24	20.91
A43242-2597	Gray	23.56	21.20
A43242-4747	Inferno Orange	29.83	26.85
A43242-7387	Kelly Green	25.20	22.68
A43242-8267	Khaki	22.89	20.60
A43242-4927	Lemon Yellow	21.58	19.42
A43242-6037	Lilac	21.90	19.71
A43242-3757	Lo Crock Flag Red	27.52	24.77
A43242-3047	Magenta	26.20	23.58
A43242-3347	Maroon	21.25	19.13
A43242-3817	Missile Red	29.83	26.85
A43242-5947	Mono Blue	24.22	21.79
A43242-5047	Navy Blue	22.89	20.60
A43242-4517	Orange	26.20	23.58
A43242-4847	Orbit Yellow	32.52	29.26
A43242-5217	Peacock Blue	21.25	19.13
A43242-7067	Phosphorescent Green	104.23	93.81
A43242-4537	Primrose Yellow	21.58	19.42
A43242-3727	Rose Magenta	28.83	25.95
A43242-5057	Royal Blue	22.89	20.60
A43242-3087	Scarlet Red	26.83	24.15
A43242-8127	Sienna Brown	21.25	19.13
A43242-5707	Solar Blue	29.83	26.85
A43242-1697	Super Opaque White	21.11	18.99
A43242-7047	Tahiti Green	26.20	23.58
A43242-7867	Traffic Green	32.81	29.53
A43242-5237	Ultramarine	22.89	20.60



B Union™ Aerotex Textile Ink

Bright colors are for application on white, light, and medium-colored garments — cotton, cotton/polyester blends, and many synthetic fabrics (except nylon). Soft hand, waterbased inks cure with or without a dryer. White may be printed as a separate color, or may be added to other colors for increased opacity. **Colors can be assorted for quantity pricing.**

NUMBER	COLOR	EACH	12/EA
A43221-2027	Black	\$12.22	\$11.71
A43221-3077	Bright Red	16.92	16.21
A43221-8007	Brown	15.26	14.63
A43221-4067	Lemon	14.81	14.18
A43221-5007	Mono Blue	16.44	15.76
A43221-5047	Navy Blue	16.44	15.76
A43221-6417	Royal Purple	15.74	15.09
A43221-2007	Shimmer Black	23.76	22.51
A43221-9007	Shimmer Gold	23.76	22.51
A43221-7347	Shimmer Mint Green	23.76	22.51
A43221-3777	Shimmer Pink	23.76	22.51
A43221-5917	Shimmer Powder Blue	23.76	22.51
A43221-6007	Shimmer Purple	23.76	22.51
A43221-3007	Shimmer Red	23.76	22.51
A43221-9307	Shimmer Silver	23.76	22.51
A43221-7077	Shimmer Walnut	23.76	22.51
A43221-7337	Shimmer Green	15.03	14.40
A43221-1017	White	19.03	18.22
A43221-1007	Extender	11.78	11.28

0.5 oz (15 ml)

NUMBER	COLOR	EACH	12/EA
A43221-1001	Catalyst	\$3.30	\$3.03

C Union™ Maxopake Liberty Series Ink

The most opaque plastisol colors available. Recommended for direct manual printing or machine printing on black and dark-colored garments. Even the neon colors are bright and highly opaque. **Colors can be assorted for quantity pricing.**

NUMBER	COLOR	EACH	12/EA
A43252-5487	Bright Blue	\$26.52	\$23.88
A43252-1427	Bright Cotton White	23.87	21.49
A43252-7257	Bright Green	27.19	24.48
A43252-3077	Bright Red	31.79	28.61
A43252-4097	Golden Yellow	30.82	27.74
A43252-4017	Lemon Yellow	29.95	26.96
A43252-4517	Orange	31.79	28.61
A43252-5057	Royal Blue	29.26	26.35
A43252-3087	Scarlet Red	31.79	28.61
A43252-1607	Extender Base	21.03	18.93
A40324-1007	Reducer/Deackifier	19.35	17.41

For more Union™ UltraSoft Maxopake Liberty Series Inks Colors, visit DickBlick.com.

SPEEDBALL®



D-H Speedball® Screen Printing Kits

Speedball presents a variety of kits for learning and perfecting your screen printing techniques on paper, cardboard, wood, and fabric. All kits include an easy-to-read instruction book and a comprehensive selection of materials. For complete kit contents, visit DickBlick.com.

D Beginner Paper Stencil Kit — Includes 10" x 14" screen frame, squeegee, Screen Printing Ink, 4 oz jar, Bienfang Graphics 360 Marker Paper Pad, Craft stick, utility knife, and instructions.

E Introductory Kit — Includes 10" x 14" screen, squeegee, screen printing inks, drawing fluid, screen filler, screen cleaner, 360 marker paper pad, knife, paintbrush, mixing sticks, and instructions.

F Intermediate Deluxe Kit — Designed for the serious enthusiast, this kit includes 8" x 10" frames, six 4 oz (118 ml) jars of ink, squeegees, and much more.

G Intermediate Kit — This super all-in-one kit has everything you need to screen print on a variety of fabrics, including a 10" x 14" screen, squeegee, inks, screen filler, photo emulsion, remover, and sensitizer.

H Screen Printing Essential Tools Kit — All the tools you need to start screen printing. Just add your own choice of inks from our fabulous color selection (pages 393–396).

I Speedball® Advanced All-in-One Kit

All the essentials you need for the photo emulsion screen printing process — one of the most exciting screen printing techniques with the widest range of possibilities. Includes transparency film, screen frame, fabric inks, diazo photo emulsion, diazo sensitizer, 9" squeegee, photo emulsion remover, exposure lamp, 250 watt photo flood bulb, black paper, exposure chart/instructions, and an instructional DVD. For more details, visit DickBlick.com.

J Speedball® Diazo Light Kit

Includes exposure lamp with 250 watt photo flood bulb and black background paper.

K Speedball® Speed Clean™ Screen Cleaner

This highly effective screen-filler remover and screen cleaner makes cleaning a breeze! Apply to both sides of screen, scrub, and apply again. In just 3–5 minutes, screens come clean using hot water and a nylon brush.

NUMBER	DESCRIPTION	EACH	6/EA
A43431-1009	Kit	\$129.15	\$116.20
A38016-1009		\$45.83	\$41.26

NUMBER	DESCRIPTION	EACH
A37900-1006	16 oz (473 ml) Squeeze Bottle	\$8.26
A37900-1007	32 oz (946 ml) Squeeze Bottle	13.81
A37900-1009	1 Gallon (3.78 liter) Jug	31.34





Blick® Complete Photo/Fabric Screen Printing Kit

Teach photo process screen production to your art students or yourself, using these safe, non-toxic products. Materials included are suitable for printing on fabric or paper. The kit contains enough emulsion to coat 10 or more screens, materials to make screen positives, plus everything else you need, including the light source:

- Blick Garment Printing Machine
- Lamp with 250 watt Photoflood Bulb
- 5, 32 oz (946 ml) Bottles of Fabric Screen Ink
- Diazo kit
- 12" x 8" Screen printing frame
- 10" Squeegee (50 durometer)
- Acrylic film 12-sheet package
- 2 Elmer's Black Painters Markers
- 2 oz (59 ml) bottle Super Black
- 32 oz (946 ml) bottle Speed Clean
- Brush
- "Screen Printing: Contemporary Methods and Materials" book
- Roll of solvent-resistant tape

NUMBER	EACH
A44907-1009	\$583.00



DIY Print Shop® Screen Printing Kits

Need to print posters, flyers, or T-shirts for your band or upcoming gig? DIY Print Shop has got you covered! The best do-it-yourself kits on the market, these kits include absolutely everything you need to reach out to your fans and customers. All of the products are environmentally safe, which means you can use them in your home or business with a clear conscience. Both kits include a DVD and instruction manual that cover every step of the screen printing process. What's more, the printing inks are waterbased, which means they can be used on cotton, 50/50 blends, canvas, uncoated paper, and wood. For complete kit contents, visit DickBlick.com.

NUMBER	DESCRIPTION	EACH
A40327-1009	Gig Poster Kit	\$320.00
A40327-2009	T-Shirt Kit	275.59



Daler-Rowney® System 3 Waterbased Screen Printing Set

An ideal set for beginning screen printers. Print posters, ads, artwork, cards, and even clothing designs. For complete set contents, visit DickBlick.com.

NUMBER	EACH
A43028-1019	\$137.44



AWT® Pro-Light I™ Direct Method Exposure Unit

This self-contained unit has a vacuum and long-lasting LED light strips. The LEDs use a specific UV spectrum to expose emulsions quickly for clear fine line and detail exposures. The non-porous, flexible rubber blanket maintains perfect contact between the positive and screen. Easy-to-use controls, including a 15-minute timer. Setup and maintenance instructions included. 115V.

NUMBER	SIZE	EACH
A43015-1001	23" x 25"	\$5308.00
A43015-1002	29" x 51"	7233.00
A43015-1003	51" x 73"	11673.00

Optional Legs for Exposure Unit — Truck Shipment and FOB Factory. See page 648 for details.

NUMBER	DESCRIPTION	EACH
AF43015-1105	23" x 25"	\$616.00
AF43015-1107	29" x 51"	647.00
AF43015-1008	51" x 73"	772.00

Optional Shelves for Unit Legs

NUMBER	DESCRIPTION	EACH
A43015-1205	23" x 25"	\$257.33
A43015-1207	29" x 51"	272.93
A43015-1108	51" x 73"	304.00



First-Quality 50/50 White T-Shirts

These T-shirts are made from a comfortable blend of 50% polyester and 50% cotton.

Adult Sizes				Youth Sizes			
NUMBER	SIZE	EACH	12/EA	NUMBER	SIZE	EACH	12/EA
A44927-1000	Small	\$7.27	\$6.53	A44959-1040	X-Small 2-4	\$4.53	\$4.07
A44927-1100	Medium	7.27	6.53	A44959-1041	Small 6-8	4.53	4.07
A44927-1200	Large	7.27	6.53	A44959-1042	Medium 10-12	4.53	4.07
A44927-1300	X-Large	7.27	6.53	A44959-1043	Large 14-16	4.53	4.07

HEALTH & SAFETY ICONS: ●=CL / ■=Prop 65 / ▼=CL & Prop 65
See page 644 for more information.

durometers

**45 is Extra Soft;
75 is Bone Hard.**

Soft blades deposit more color than hard blades and are better for textile printing. Hard blades are better for hard, smooth surfaces and will conserve your ink.



Speedball® Graphic Squeegees

The Speedball Graphic Squeegee is designed for graphic screen printing but can also be used on paper, cardboard, or wood. Available in a variety of sizes, it features a wood handle and a firm, durable urethane blade that is suitable for shorter print runs and high-usage applications. The blade is impervious to acids, turpentine, and thinners.

NUMBER	LENGTH	EACH
A48907-1006	6"	\$18.77
A48907-1008	8"	21.89
A48907-1010	10"	27.17
A48907-1012	12"	31.28
A48907-1014	14"	35.64
A48907-1016	16"	40.64
A48907-1018	18"	45.72
A48907-1020	20"	50.81



Speedball® Fabric Squeegees

Designed specifically for screen printing on fabric, these squeegees have rounded edges that reduce the occurrence of binding while pushing more ink through the screen. The 65 durometer nitrile blade is suited for shorter print runs. Wood handles.

NUMBER	LENGTH	EACH
A44960-1006	6"	\$10.91
A44960-1008	8"	12.87
A44960-1010	10"	14.83
A44960-1012	12"	16.85



Oval Poly Sponges

Soft and absorbent. Chemical- and grease-resistant.

NUMBER	APPROX.	EACH	12/EA
A32902-1000	5" x 3" x 2"	\$1.64	\$1.48
A32902-1001	6" x 4" x 2-1/2"	2.42	2.18

BLICK® squeegees

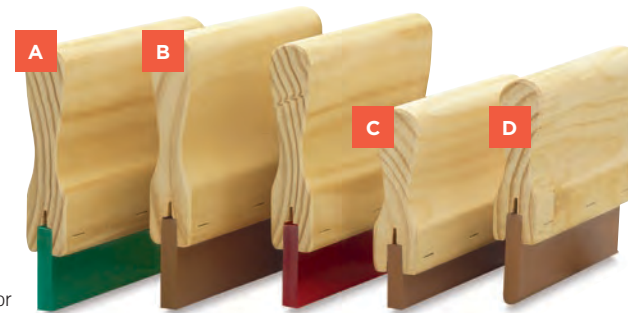

A-D Blick® Squeegees

Blick Squeegees are manufactured to our high standards. Kiln-dried and precision-cut lumber is used for the non-warp handles, which are smooth, comfortably shaped, and easy to work with. The blades are molded under high heat and pressure and have a tensile strength of more than 2,000 lb, which eliminates ink streaking and provides a superior, long-lasting printing edge. They're inserted into the wood handle and stapled in position, then professionally sharpened after assembly. Use for both graphic and textile applications, for all hand printing, and for many machine applications. Excellent abrasion and solvent-resistance. (Squeegee blade color may vary from image shown.)

A 70-75 Durometer Squeegee — Medium. 3/8"W x 1-7/8" thick color-coded blade. Used for general printing. Medium ink deposit.

NUMBER	LENGTH	EACH
A37200-1006	6"	\$16.77
A37200-1008	8"	22.36
A37200-1010	10"	27.94
A37200-1012	12"	33.53
A37200-1014	14"	39.11
A37200-1016	16"	44.70
A37200-1018	18"	50.30

B 65 Durometer Polyurethane Squeegee — Medium. 3/8"W x 1-7/8" thick tan blade. Flat, firm blade is best-suited for printing graphic images on a smooth finish paper.

NUMBER	LENGTH	EACH
A37201-1006	6"	\$10.19
A37201-1008	8"	13.58
A37201-1010	10"	16.95
A37201-1012	12"	20.37
A37201-1014	14"	23.77
A37201-1016	16"	27.17
A37201-1018	18"	30.56

C 60-65 Durometer Squeegee — Medium/soft. 3/8"W x 1-7/8" thick urethane color-coded blade or standard, tan blade. Use with a wide range of meshes and ink viscosities on even surfaces with minimum texture.

NUMBER	DESCRIPTION	EACH
A37202-1006	6", Urethane	\$17.13
A37202-1008	8", Urethane	22.84
A37202-1010	10", Urethane	28.55
A37202-1012	12", Urethane	34.26
A37202-1014	14", Urethane	39.97
A37202-1016	16", Urethane	45.68
A37202-1018	18", Urethane	51.39
A37203-1006	6", Standard	10.03
A37203-1008	8", Standard	13.35
A37203-1010	10", Standard	16.67
A37203-1012	12", Standard	19.99
A37203-1014	14", Standard	23.31
A37203-1016	16", Standard	26.68
A37203-1018	18", Standard	30.03

D 50-55 Durometer Squeegee — Soft. The 3/8"W x 1-7/8" thick, rounded, transparent yellow blade is used for printing through coarser mesh counts to lay down a heavy deposit of ink on dark backgrounds, athletic wear, or absorbent materials such as fleece.

NUMBER	LENGTH	EACH
A37204-1006	6"	\$12.04
A37204-1008	8"	16.05
A37204-1010	10"	20.07
A37204-1012	12"	24.07
A37204-1014	14"	28.09
A37204-1016	16"	32.10
A37204-1018	18"	36.11



3M® Commercial Cellulose Sponge

Ten times more absorbent than polyurethane sponges, plus stronger and less likely to fall apart. Measures 6" x 4" x 1-1/2" — ideal for cleanup in the studio, classroom, or home.

NUMBER	EACH	12/EA
A38014-1006	\$3.30	\$2.97



AWT® Stainless Steel Ink Spatulas

All-purpose spatulas have rosewood handles and brass rivets. Semi-flexible flat blade is ideal for stirring inks and mixing colors. Also used for removing excess ink from squeegees and screens. Great for cleanup.

NUMBER	LENGTH	EACH	6/EA
A44921-1006	6"	\$14.79	\$13.84
A44921-1008	8"	17.07	15.98
A44921-1000	10"	21.13	19.77

WARNING! Products marked with a Prop 65 symbol (■ or ▼) can expose you to chemicals, including cadmium, which are known to the State of California to cause cancer and birth defects or other reproductive harm. For more information, visit P65Warnings.ca.gov.

BLICK® "drum-tite" screen frames

These production-quality frames are made with smoothly sanded, sap-free, non-warping wooden balusters, accurately mitered and securely fastened together to last through numerous runs. The fabric is cord-stretched on the balusters, which are grooved for restretching by the cord method.

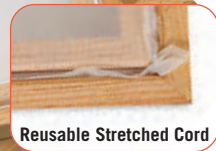

Blick® Assembled Frame with 110 Monofilament Polyester Mesh

Monofilament fabric consists of single strands of manmade fibers with uniform construction and spacing, plus the finest uniform diameter threads. Holds fine details for printing four-color process work. Includes a stretch-tite cord for easier re-stretching. Excellent where tight register of colors is required. Also used for graphic applications where clean, crisp definition is required, such as decals, signs, and book covers. Baluster size is 1-1/8" x 1-1/8".

NUMBER	SIZE	EACH	12/EA
A43429-1012	8" x 10" x 1"	\$20.38	\$18.34
A43429-1003	10" x 12" x 1"	22.14	19.93
A43429-1004	10" x 14" x 1"	22.05	19.85
A43429-1006	12" x 18" x 1"	32.98	29.68
A43429-1008	16" x 20" x 1"	31.35	28.21

Blick® Wooden Balusters

Make your own economical screen frames from Blick's already mitered and grooved frame pieces. They can be assembled any way you choose, using nails, staples, or glue. Be sure to order two for width and two for length. Four are required for a frame. Pick your fabric by the yard, and use cordsetter and cord to finish the frame. Baluster size is 1-1/8" x 1-1/8". Larger 1-5/8" balusters are available by special order — call for prices.

NUMBER	LENGTH	EACH	12/EA
A43419-1008	8"	\$1.37	\$1.23
A43419-1010	10"	1.83	1.65
A43419-1012	12"	2.11	1.90
A43419-1014	14"	2.36	2.13
A43419-1016	16"	2.59	2.33
A43419-1018	18"	3.05	2.75
A43419-1020	20"	3.42	3.08



< Speedball® Monofilament Aluminum Screen Printing Frames

Strong, reliable, and highly durable, these high-quality, pre-stretched screen printing frames are made from the highest grade of aluminum, coupled with a high-precision woven mesh that is pneumatically stretched to industry-standard tensions. The frames are hand-cut, welded for a watertight seal, and ground smooth for flatness and flawless edges. Designed for longevity, they can be stretched and restretched repeatedly. Made in the USA.

White Mesh				
NUMBER	SIZE	GRADE	EACH	12/EA
A44969-1102	20" x 24"	110	\$47.36	\$42.63
A44969-1552	20" x 24"	155	49.35	44.42
A44969-1553	23" x 31"	155	64.55	58.10
A44969-1555	25" x 36"	155	103.48	93.14

Yellow Mesh				
NUMBER	SIZE	GRADE	EACH	12/EA
A44969-2302	20" x 24"	230	\$51.99	\$46.80
A44969-3052	20" x 24"	305	68.43	61.60
A44969-2303	23" x 31"	230	71.68	64.52

< AWT® Fabric Cleaning Brush

For pre-cleaning screen fabrics. Stiff 7/8" plastic bristles work cleaning agents into material to work up to "tooth" for best film adhesion. Bristles are set in 5-1/2" x 2-3/8" wood block.

NUMBER	EACH	3/EA
A44905-0000	\$17.93	\$16.13



Printer's Edge Aluminum Screen Printing Frames

These heavy-gauge, watertight frames are stretched with your choice of mesh. Crafted of best-quality aluminum alloy, they feature fully welded corners that are ground to a smooth finish.

White Mesh				
NUMBER	SIZE	GRADE	EACH	12/EA
A43432-1109	18" x 20" x 1-3/8"	110	\$33.51	
A43432-1102	20" x 24" x 1-3/8"	110	34.28	
A43432-1103	23" x 31" x 1-1/2"	110	47.99	
A43432-1602	20" x 24" x 1-3/8"	156	37.22	
A43432-1603	23" x 31" x 1-1/2"	156	51.19	

Yellow Mesh				
NUMBER	SIZE	GRADE	EACH	12/EA
A43432-4232	20" x 24" x 1-3/8"	230	\$39.18	
A43432-4233	23" x 31" x 1-1/2"	230	55.46	
A43432-4302	20" x 24" x 1-3/8"	305	55.46	
A43432-4303	23" x 31" x 1-1/2"	305	68.26	

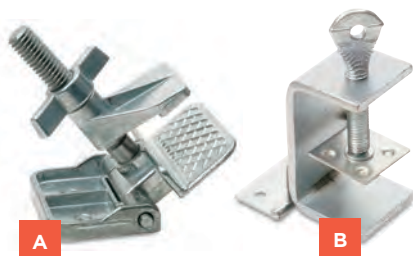

A Speedball® Deluxe Hinge Clamps

Fabricated from cast aluminum with wide-wing thumbscrews for firm fastening to frame. Positive locking for perfect registration. Set of two.

NUMBER	EACH	6/EA
A44920-0000	\$33.42	\$30.08

B Heavy-Duty Hinge Clamps

Heavy, cadmium-plated steel. Wide, flat jaws hold any frame with a 5/8" to 1-7/8" baluster firmly without gouging. Piano hinges. Set of two.

NUMBER	EACH	12/EA
A44912-0000	\$10.91	\$9.82

Sprayway® Screen Opener

Opens up dried-up ink areas without leaving a film. It is best used with plastisol inks, and only on screens made with photographic (direct or indirect) stencils or lacquer-proof knife-cut films. 20 oz (591 ml) aerosol can.



NUMBER	EACH	12/EA
A44949-1030	\$10.24	\$9.22

screen fabrics

Screen Printing is so named because a print is made by pushing ink through a screen to make an image. The fabrics most commonly used in screen printing are either monofilament or multifilament polyester. These fabrics are reclaimable, good for long runs, and usable in many different areas.

Monofilament Fabric is woven of a single thread. It is uniform in weave, giving a smoother ink flow and resulting in a sharper print. Monofilament fabric mesh count is determined by the number of threads per linear inch. The fewer threads per inch, the larger the size of the openings and the more space for ink to get through the fabric. Monofilament fabrics are designated by a number, such as 86 or 109.

Multifilament Fabric is woven of a twisted-strand thread. Multifilament fabric is less uniform in weave but has more tooth for easier adhering of stencils and heavier ink deposit. The coarseness of the fabric is indicated by a number followed by an XX, with 6XX being the coarsest. The above chart shows a rough equivalent between monofilament and multifilament fabrics.

Monofilament	Multifilament
86	6XX
109	8XX
124	10XX
140	12XX
180	14XX
232	16XX

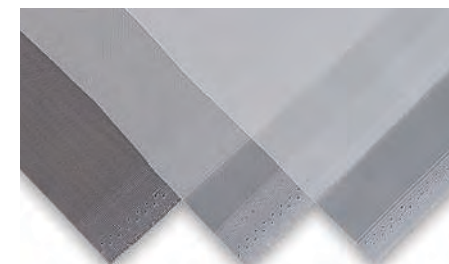

Monofilament Polyester Screen Fabric

White, anti-halo monofilament polyester is especially good for four-color process and close-tolerance screen printing. Excellent for fine detail. Uniformly woven of the finest polyester monofilament thread.

45" x 1 yd				
NUMBER	INCH COUNT	EACH	50/EA	75/EA
A43405-1086	86	\$14.10	\$12.69	\$12.06
A43405-1109	110	14.10	12.69	12.06
A43405-1124	125	14.10	12.69	12.06
A43405-1140	140	14.10	12.69	12.06
A43405-1160	160	16.20	14.58	13.86
A43405-1200	200	18.84	16.95	16.12
A43405-1305	305	30.63	27.57	26.21

55" x 1 yd				
NUMBER	INCH COUNT	EACH	50/EA	75/EA
A43405-1074	74	\$14.10	\$12.69	\$12.06
A43405-1232	232	22.37	20.13	19.14



Orange Monofilament Polyester Screen Fabric

Orange screen fabric is designed for the photographic screen process. While some white fabric may reflect light and cause a halo effect on the edges of your image, orange fabric ensures a sharp reproduction of fine lines and letters, even half-tones.

42" Wide Orange Monofilament Polyester				
NUMBER	INCH COUNT	EACH	50/EA	75/EA
A43402-4516	160	\$18.84	\$16.95	\$16.12
A43402-4520	200	20.71	18.64	17.72
A43402-4523	232	26.22	23.60	22.40



Blick® Tite-Stretch Cord

Uniform diameter for a perfect, non-slip fit.

NUMBER	CORD DIA.	REEL	EACH	12/EA	24/EA
A44911-0000	11/64"	300 ft	\$40.50	\$36.45	\$34.63
A44911-0100	11/64"	100 ft	8.80	7.92	7.52
A44911-0300	9/64"	300 ft	32.70	29.11	28.05

AWT® Cord Setter

This easy-to-operate tool presses the cord into the groove with the tap of a hammer for tightest stretch. Smooth finish, palm-fitting, hard plastic handle with tempered hard steel blade. Frame baluster reamer mounted on handle. Blade is 5"L x 1"W. Handle is 3-1/4" long.

NUMBER	EACH
A43101-1005	\$22.33

C Kraft Paper Tape

Traditional gummed, 60 lb packaging tape creates a strong, long-lasting seal on boxes and cartons. Moisten to use. 1-1/2" core.

NUMBER	SIZE	EACH	10/EA
A24118-1002	2" x 600 ft	\$9.15	\$8.23
A24118-1003	3" x 600 ft	14.09	12.68

D AWT® Red Polyethylene Screen Tape

This flexible, low-cost, and high-tack pressure-sensitive tape is ideal for sealing screens. Solvent- and water-resistant. 36 yd roll.

NUMBER	WIDTH	EACH	6/EA
A44903-3002	2"	\$8.71	\$7.84
A44903-3003	3"	15.75	14.18

E Screen Tape

No more hassles with masking, cloth, or gummed tape! This tape is a 2-mil polyester film, coated with pressure-sensitive adhesive. It is water-, humidity-, and solvent-resistant. Use it as an edge-sealing tape or even as a screen mesh patch. Tape is 3" wide.

NUMBER	YARDS	EACH	3/EA
A44902-1003	50	\$27.10	\$24.40
A44902-1103	200	143.30	128.99

F PMI QuickRip Blockout Tape

This blue, non-adhesive tape can be torn by hand and removes easily without breaking or leaving residue behind. Use it for taping off registration marks and pinhole leaks. 2" wide x 60 yd roll.

NUMBER	EACH	6/EA
A38044-1060	\$14.56	\$13.10



Speedball® Block Out Tape

Ideal for screen printing techniques, this tape is easy to apply and remove from frames and mesh, and it doesn't leave adhesive residue behind. The self-wound polyethylene tape is coated with a super sticky, waterbased adhesive that resists solvents. The adhesive is also waterproof and strong enough to withstand multiple pressure/solvent wash baths. 36 yd x 2"W roll.

NUMBER	EACH	4/EA
A48926-5012	\$12.42	\$11.15



G AWT Solvent and Water Resistant White Cloth Tape

Seal and protect all types of frames. This tape has a strong, high-tack formula for a long-lasting hold. It's coated in durable cloth-polyethylene to withstand the toughest solvents, yet it can be removed easily. 2"W x 60 yds long.

NUMBER	EACH	4/EA
A38055-1260	\$32.22	\$28.99

watersoluble handcut screen films



Ulanocut Green Watersoluble Film

A highly transparent film with .003" polyester backing for excellent stability. Sticks back for corrections. Use with all inks except waterbased. Remove with warm water. Use all-purpose, waterbased block-outs. This type of film adheres to the screen with water. Wash out film with warm water.

NUMBER	SIZE	EACH
A43320-7140	40" x 300" Roll	\$213.95



Ulanoc Stencil Remover No. 4

Easy-to-use liquid for removing direct emulsion or CDF direct films from screens. Fast action on all types of fabric. Contains no strong alkaline or hypochlorites. Will not etch fabrics. Odorless.

NUMBER	SIZE	EACH
A43310-1007	Quart (946 ml)	\$17.65
A43310-1009	Gallon (3.78 Liter)	56.99



Blockout Pens

Flash dry blockout for pinhole and general screen repair. Replaces masking tape as the quick fix for jobs in progress. Blocked out pinholes stand up to repeated screen wipings. Always perform suitability/compatibility tests before use in actual production.

Red — Fast-drying, water-soluble (10–15 min.). Recommended for use during screen preparation. Works with all stencil systems. Resists virtually all solvent-based, plastisol, and UV inks. Reclaims with tap water.

NUMBER	EACH	12/EA
A44928-3000	\$9.91	\$8.92

Green — Ultra-fast drying, water-soluble (30 sec.–1-1/2 min.). Recommended for on or off the press touch-up of direct stencil systems. Resists plastisol, UV, and most solvent-based inks. Reclaims with tap water.

NUMBER	EACH	12/EA
A44928-7000	\$9.91	\$8.92

Blue — Quick-drying (15–20 min.), reclaimable. Recommended for use during screen preparation. Works with all stencil systems. Resists water-based, plastisol, UV, and some solvent-based inks. Reclaims with stencil remover.

NUMBER	EACH	12/EA
A44928-5000	\$9.91	\$8.92

Nitrile Rubber Gloves

With great chemical resistance and protection from cuts, abrasions, and punctures, nitrile gloves are practical, durable, and comfortable. Two-color construction provides wear indicator. Features an embossed surface for safe, secure grip. 13" long.

NUMBER	SIZE	EACH	12/EA
A32907-0200	Small Pair	\$7.12	\$6.41
A32907-0100	Medium Pair	7.12	6.41
A32907-0000	Large Pair	7.12	6.41

photo-sensitive indirect screen films

This pre-sensitized film is adhered to the screen after it has been exposed and developed, but while it is still wet. For use with solvent-based inks, including plastisol. Best for fine detail and half-tone dots.

Pre-Sensitized Film Developer

A and B pre-measured developer for pre-sensitized indirect films. One packet each of A and B powder mixed with warm water makes one pint (473 ml) or one quart (946 ml) of developer, respectively.

NUMBER	PACKETS	EACH
A43322-1006	8 (makes 8 pints)	\$41.17
A43322-1007	20 (makes 20 quarts)	102.89

Ulanoc Enzyme No. 1

For removal of indirect, pre-sensitized stencil film from all types of screen fabric. Odor-free. Use with water-soluble films.

NUMBER	SIZE	EACH
A43308-0000	Quart (946 ml)	\$59.10

Ulanoc No. 60 Screen Filler

Water-based block-out, best for use with solvent-based inks. Thin with cold water for touch-ups. For use with water-soluble films.

NUMBER	SIZE	EACH
A43311-1007	Quart (946 ml)	\$15.41

Ulanoc Proclaim Emulsion

This fast-drying, diazo-photopolymer, dual-cure emulsion provides unequalled exposure latitude, even if underexposed and used with aggressive inks and solvents. Superb coating properties and durability; resistant to all water-based UV-cured and solvent-based inks. For general graphics, textile and industrial applications.

NUMBER	SIZE	EACH
A47105-5017	Quart (946 ml)	\$29.64
A47105-5019	Gallon (3.78 Liter)	64.50



Ulanoc Proclaim™ EC Emulsion

Proclaim EC is a ready-to-use, diazo-free, dual-cure emulsion that eliminates diazo mixing, stirring, and de-bubbling. This breakthrough technology is formulated to provide unequalled exposure latitude and ease of de-coating, even if underexposed and used with aggressive inks and solvents. It's fast exposing and provides good acutance. Plus, a high solid content (37%) provides good stencil build per coat, excellent mesh bridging, and quick drying. Proclaim EC has superb coating properties and durability, and is resistant to all solvent-based inks, as well as water-based UV-cured inks. Ideal for general graphics, textile, and industrial applications.

NUMBER	SIZE	EACH
A44066-1007	Quart (946 ml)	\$31.07
A44066-1009	Gallon (3.78 Liter)	67.56



Ulanoc Rubylith Masking Film

A red masking film that offers extended spectral protection. Safe for use with camera-speed darkroom films, plus indirect gelatin stencil films and diazo, diazo acrylic, or SBQ sensitized stencil films or emulsions. For additional product details, visit DickBlick.com.

NUMBER	SIZE	EACH
A23203-2109	20" x 24" Sheet	\$7.04

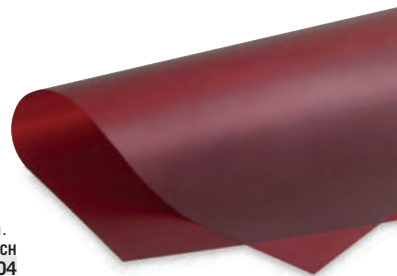

guide to screen printing films and emulsions

We want to help! Below is a chart that lists usage procedures for screen printing films and emulsions to answer many of the questions you may have. Keep in mind, these are merely suggestions.

Stencil	Uses	Blockout	Remover	Compatible Inks	Adheres With	Develops With
Hand-Cut Films						
Ulanoc S3S Sta-Sharp	Multi-Purpose	Screen tape page 401	Lacquer thinner	Any ink but lacquer, vinyl, or plastisol	Ulanoc Adhering Liquid	—
Ulanocut Green	Multi-Purpose	Ulanoc Screen Filler No. 60 pg 402. Screen tape page 401	Hot or cold water	Any ink but water-based	Water	—
Ulanoc AMBA	Multi-Purpose	Ulanoc Screen Filler No. 60 pg 402. Screen tape page 401	Hot or cold water	Any ink but water-based	Water	—
Mask Ease	Multi-Purpose	Its own non-cut surface or screen tape page 401	Peel off	Water-based only	Is pressure sensitive	—
Scratch-A-Print	Multi-Purpose	—	—	Water-based only	—	Scratching tool (pen or pencil)
Photo-Sensitive Direct Films						
Riso Thermal Screen	Multi-Purpose	—	—	Water-based only	Apply to plastic screen frame	Thermal copier
Ulanoc CDF/Matrix	Multi-Purpose	Screen tape page 401	Water	Most solvent-based, water-based, plastisol, and UV	Water	Water
Photo-Sensitive Indirect Films						
Ulanoc Blue Poly-2	Multi-Purpose	Ulanoc Screen Filler No. 60 pg 402. Screen tape page 401	Ulanoc Enzyme No. 1 page 402	Solvent-based inks	Water	Ulanoc Pre-Sensitized Film Developer page 402
Ulanoc Hi-Fi Green	Multi-Purpose	Ulanoc Screen Filler No. 60 pg 402. Screen tape page 401	Ulanoc Enzyme No. 1 page 402	Oil-based, solvent-based, or plastisol	Water	Ulanoc Pre-Sensitized Film Developer page 402
Ulanoc Pulsar	Multi-Purpose	Ulanoc Screen Filler No. 60 pg 402. Screen tape page 401	Ulanoc Stencil Remover No. 4 page 402	Solvent-based inks	Water	Water
Diazo Direct Emulsions						
Ulanoc Fotocoat FX 88-SR	Weaker light source	Ulanoc Screen Filler No. 60 pg 402. Screen tape page 401	Ulanoc Stencil Remover No. 4 page 402	Oil-based and solvent-based	Spread emulsion or use emulsion coater	Water
Ulanoc Fotocoat TZ	Multi-Purpose	Coat close to edge & use screen tape page 401	Ulanoc Stencil Remover No. 4 page 402	Water-based and plastisol	Spread emulsion or use emulsion coater	Water
Speedball Diazo Emulsion	Multi-Purpose	Coat close to edge & use screen tape page 401	Ulanoc Stencil Remover No. 4 page 402	Most inks	Spread emulsion or use emulsion coater	Water
Ulanoc QTX	Multi-Purpose	Coat close to edge & use screen tape page 401	Ulanoc Stencil Remover No. 4 page 402	Water-based and plastisol	Spread emulsion or use emulsion coater	Water

There are two types of hand-cut film. If you want to print with water-based inks, use lacquer-based film, which requires a strong, flammable solvent to make it adhere to the screen. Use caution and good ventilation. Once the screen is ready, you can print with any water-based or solvent-based inks — except lacquer, vinyl, or plastisol. If you want to print with lacquer, vinyl, plastisol, or solvent-based ink, use water-soluble film. It adheres to the screen with cool water and washes out with warm water when the job is done.



Scratch-Art Mask-Ease™

The safest and easiest masking system for water-based silkscreen printing — the low-cost and solvent-free way! Just cut your artwork directly into the special plastic sheet using any cutting blade, then apply the sheet to the screen fabric. The cut out spaces will provide the windows for the final print. Each set contains one yellow vinyl sheet with adhesive and liner, one polypropylene sheet with adhesive and liner, and instruction sheets.

NUMBER	SIZE	EACH	3/EA
A44908-1005	10" x 15" Set	\$6.40	\$5.76
A44908-1003	20" x 30" Set	12.75	11.48



AWT Safe-T-Wash™

A special blend of cleaning solutions for safe and effective cleaning of all inks used in the screen printing process. This solution has a low VOC rating and conforms to or exceeds most guidelines. Dissolves all ink systems efficiently with a minimum of time and effort.

NUMBER	SIZE	EACH	6/EA
A43327-1007	Quart (946 ml)	\$23.91	\$21.52
A43327-1009	Gallon (3.78 Liter)	60.41	54.37



Crown™ Lacquer Thinner

A general-purpose, medium-dry grade lacquer thinner for thinning clear and pigmented lacquer-based inks and paints, and for removing lacquer-based hand-cut film from screens. Good for cleaning brushes and rollers, and for degreasing parts. Do not use to thin automotive lacquers.

NUMBER	SIZE	EACH	6/EA
A44958-1007	Quart (946 ml)	\$12.29	\$11.06

HEALTH & SAFETY ICONS: ●=CL / ■=Prop 65 / ▼=CL & Prop 65
See page 644 for more information.

WARNING! Products marked with a Prop 65 symbol (■ or ▼) can expose you to chemicals, including cadmium, which are known to the State of California to cause cancer and birth defects or other reproductive harm. For more information, visit P65Warnings.ca.gov.



Ulano® Screen Degreaser No. 3

Non-caustic solution for removing oil and sizing from new or old screens. Use before stencil film application and after ink removal. Speeds action of stencil remover and wash-up. Films and emulsions will not adhere to greasy or dirty screens. Degreaser is effective even in hard water; rinses clean with hot or cold water.

NUMBER	SIZE	EACH
A43309-1007	Quart (946 ml)	\$16.62



Ulano® Fotocoat FX88-SR Fast Film Emulsion

This emulsion is solvent-resistant and for use with weaker light sources. Allows for some margin of error in exposure. Outstanding print quality. Diazo sensitizer included. Great for high volume production. Use polyester fabric for best results. Washes out of screen with Ulano Stencil Remover No. 4. Use No. 60 Screen Filler.

NUMBER	SIZE	EACH
A43313-1007	28 oz (828 ml)	\$49.96
A43313-1009	Gallon (3.78 Liter)	87.92



Ulano® QTX Pure Photo Polymer Emulsion

Resists plastisol and waterbased textile inks.

A pre-sensitized, lightning-fast exposing screen emulsion formulated specifically for textile applications. QTX's exceptionally high solids content provides unsurpassed stencil build per wet-on-wet coat, excellent bridging of coarse mesh textile meshes, fast drying, and superior definition. It has superb coating properties and is extremely durable. It's resistant to waterbased and plastisol inks, making it perfectly suited for most textile applications.

NUMBER	SIZE	EACH
A43315-1007	28 oz (828 ml)	\$39.21
A43315-1009	Gallon (3.78 Liter)	125.47

Ulano® Fotocoat TZ Diazo Screen Printing Emulsion for Waterbased Inks and Plastisols

Apply to 8XX polyester screen for textile inks. Use finer mesh for use with poster inks. For block-out, use the same emulsion. Washes out of screen with Ulano Stencil Remover No. 4. Cleans up with cold water. Sensitizer included.

NUMBER	SIZE	EACH
A43307-1007	28 oz (828 ml)	\$39.96
A43307-1009	Gallon (3.78 Liter)	91.35



Emulsion Coater

Coats screens evenly and uniformly. Designed for easy and comfortable handling while providing a smooth layer of emulsion on your screen. Made from hard, gold-anodized aluminum. Enclosures are permanent for quick cleaning without leaking. Each coater has a rubber edge protector for storage.

NUMBER	SIZE	EACH	6/EA
A43305-1007	7"	\$26.66	\$23.99
A43305-1009	9"	28.09	25.28
A43305-1011	11"	30.95	27.86
A43305-1013	13"	32.68	29.41
A43305-1015	15"	34.16	30.75



Ternes-Burton Register Pins

A stainless steel base (.013" thick) with a precision machined stainless steel button. The tops of the buttons and the bottoms of the bases are hand-polished to prevent scratches. The hole in the base provides additional taping area, which helps prevent movement and makes the pins easier to handle.

NUMBER	DESCRIPTION	SIZE	EACH	10/EA
A38023-1025	Package of 2	0.055"L x 1/4"Dia	\$12.20	\$10.98
A38023-1148	Package of 2	0.085"L x 1/4"Dia	12.20	10.98
A38023-1125	Package of 2	0.120"L x 1/4"Dia	12.20	10.98



AWT® Stainless Steel Registration Guides

Long-lasting tempered stainless steel registration guides are used for any thin stock printing application. Simply tape guides into position on the printing bed and slide stock into the same place for perfect registration, print after print. Designed for manual screen printing or semi-automatic presses.

NUMBER	DESCRIPTION	EACH	15/EA
A38000-1003	Package of 3	\$4.78	\$4.30
A38000-1012	Package of 12	13.14	11.83



Speedball® Diazo Screen Printing Emulsion & Remover

May be used effectively with either waterbased or solvent-based inks on polyester screen fabrics only. Diazo Sensitizer is required in order to use the Diazo Photo Emulsion correctly. Speedball recommends using the full 2 oz with the 26.4 oz Emulsion. For kit contents, visit DickBlick.com.

NUMBER	DESCRIPTION	EACH	6/EA
A43304-1026	Emulsion, 26.4 oz	\$26.97	\$24.27
A44961-1005	Remover, 8 oz	9.34	8.41
A43304-1002	Sensitizer, 2 oz	8.47	7.62

System Kit			
NUMBER	EACH	6/EA	
A43304-1005	\$28.99	\$26.09	

Speedball® Drawing Fluid and Screen Filler

A "tusche-like" or positive screen printing method. Brush Drawing Fluid on all areas you want to print and let dry. Next, spread Screen Filler over the entire bottom side of the screen and let dry. Finally, spray cold water onto the top of the screen to wash out the areas covered by Drawing Fluid. Use filler to touch up any pin holes. When dry, the screen is ready for printing with any waterbased ink. Remove filler by scrubbing with hot water and kitchen cleanser.

Drawing Fluid			
NUMBER	SIZE	EACH	6/EA
A43306-1005	8 oz (236 ml)	\$8.15	\$7.34
A43306-1007	32 oz (946 ml)	23.24	20.91

Screen Filler			
NUMBER	SIZE	EACH	6/EA
A43306-1105	8 oz (236 ml)	\$12.52	\$11.27
A43306-1107	32 oz (946 ml)	35.33	31.80

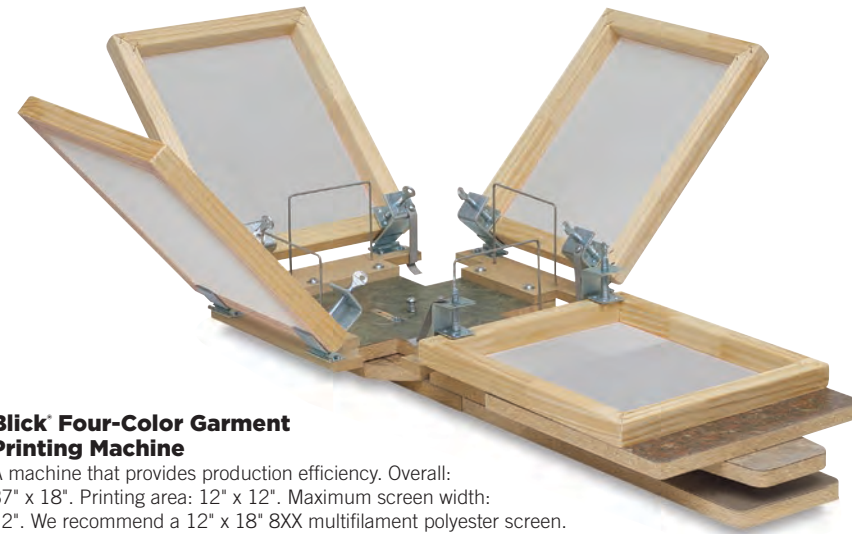

Blick® Four-Color Garment Printing Machine

A machine that provides production efficiency. Overall: 37" x 18". Printing area: 12" x 12". Maximum screen width: 12". We recommend a 12" x 18" 8XX multifilament polyester screen. This machine prints up to four colors on one shirt at a time. Screens and squeegees not included. For complete details, visit DickBlick.com.

NUMBER	EACH
A43001-1104	\$453.00

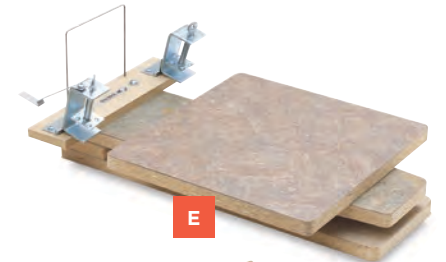

Blick® One-Color Garment Printing Machines

Ideal for beginners, schools, and clubs, these one-color units are great for printing T-shirts, jackets, scarves, and other items quickly and easily. Two heavy-duty hinge clamps hold screen frame securely. The frame automatically catches and stays in the "up" position until the operator releases it. Squeegee rests against its holder until the screen is lowered for printing. Available in a square size (shown) and a longer size for more versatility. Screens not included.

NUMBER	PRINTING AREA	EACH	10/EA
A43001-1004	12" x 12"	\$153.25	\$1137.93
A43001-1006	12" x 15"	170.85	153.78

F Standard-Grade Screen Printing Units

The back bar height is securely adjusted with wing nuts. Frame is 1-1/8" thick, with 12XX multifilament fabric, and the glued corners have corrugated metal fasteners with wood sidekick. Base is 1/4" thick hardboard. All come with three stainless steel registration guides. Squeegee included. Assembly required.

NUMBER	BAR HINGE	SQUEEGEE	EACH	12/EA
A43417-1004	10" x 14"	7"	\$70.75	\$63.68
A43417-1006	12" x 18"	9"	78.50	70.65
A43417-1008	16" x 24"	13"	94.95	84.45

Dynamic™ Four-Color Screen Printer

With optional cap printing attachment.

Simple, fast set-up and a proven registration system give you the ability to print precise four-color designs in perfect register on clothing and other items. All-steel construction. Screen head is mounted on ball bearings. Springs support screen in up or down position. Includes 14" x 14" neck platen with white, easy-clean surface. FOB Factory. See page 648 for details.



NUMBER	DESCRIPTION	EACH
AF43002-1100	1-Station without Legs	\$1150.00
AF43002-1000	1-Station with Legs	1266.00
AF43002-1003	2-Station without Legs	1266.00
AF43002-1002	2-Station with Legs	1497.00



AWT® Professional Grade Screen Printing Equipment

Maximize productivity with AWT Professional Grade Screen Printing Units.

A Screen Printing Unit with 10" Squeegee — Suitable for prototyping, short runs, classrooms, specialty work. Adjustable, cast metal hinge clamps improve production. 14" x 18".

NUMBER	EACH
A43418-1017	\$77.86

Screen Printing Unit with 14" Squeegee — Same unit as above, but measures 18" x 24".

NUMBER	EACH
A43418-1009	\$97.68

B Cure-Tex Textile Dryer — An infra-red conveyor dryer that offers a lower-cost alternative to larger dryers of its kind. Designed for maximum production speeds, it features heavy-duty chamber insulation for even, efficient heat delivery.

NUMBER	EACH
AF43011-0000	\$6035.00



C Washout Sink — Made from heavy-gauge stainless steel for long life, the Kleen-View can be used with any pressure washer. It's ideal for cleaning ink from screens, degreasing mesh, and washing out emulsions or film. Truck Shipment and FOB Factory. See page 648 for details.

D Accu-Glide Squeegee Unit — Offers a high quality yet affordable solution to screen printing short runs, prototypes, and test runs. Aluminum Stay-Flat vacuum table with adjustable legs provides a flat, rust-proof, warp-proof printing surface. Truck Shipment and FOB Factory. See page 648 for details.

NUMBER	EACH
AF43025-1015	\$3887.00



A

A

B



C

D

E

F

G

H

I

J

K

C Canvas Tote Bags

Made in the USA with 100% natural cotton canvas. Ideal for toting art supplies, drawing and sketch pads, books, and more.

NUMBER	DESCRIPTION	SIZE	EACH	12/EA
A15732-1010	With Pockets	13-1/2" x 11-1/2" x 2"	\$6.50	\$5.84
A15732-1030	With Pockets	18" x 16" x 3"	8.36	7.51
A15732-1020	No Pockets	18" x 16" x 3"	5.57	4.99

D Drawstring Backpacks

These plain backpacks are ready and waiting for personalization. They're great for kids' projects, summer camps, school spirit, and more. 100% cotton. 14-1/2" x 13-1/2".

NUMBER	COLOR	EACH	12/EA
A63970-2021	Black	\$5.07	\$4.56
A63970-8541	Natural	4.06	3.65

E Natural Cotton Zipper Bags

Stay organized in style. 100% natural cotton pouches are customizable and ready to accept painting, drawing, iron-on patches, stencils, and more. Sold in packs of three. Each pouch measures 6" x 9" with zipper closure.

NUMBER	EACH	12/EA
A01271-1003	\$7.64	\$6.87

F Craft Basics American Flour Sack Towels

The perfect tea towels for a wide variety of home décor and craft projects. Soft white color and pre-washed finish with a vintage look, they're 100% cotton and super absorbent, a green option for general household cleaning. Sold in packs of two. 28"W x 29"L. Made in the USA from imported fabric.

NUMBER	EACH	12/EA
A01276-1022	\$7.52	\$6.77

G Natural Cotton Pillow Covers

Decorate your home with natural cotton canvas pillow covers that you can easily personalize with fabric paints, stencils, dyes, jewels, iron-on appliques, and more. Covers are machine washable with zipper closures.

NUMBER	SIZE	EACH	12/EA
A63992-1020	12" x 20"	\$6.60	\$5.94
A63992-1016	16" x 16"	6.05	5.44
A63992-1018	18" x 18"	6.60	5.94

A Recycled Canvas Totes

"Tote" around art supplies, groceries, and school books in a personalized tote bag. Made from a blend of recycled cotton fabrics, they're perfect for screen printing, embroidery, and stenciling. Soft and durable, they have wide straps for comfort.

NUMBER	SIZE	EACH	6/EA
A66916-1010	8"W x 10"H x 5"D	\$5.86	\$5.27
A66916-1020	14"W x 14"H x 3"D	6.77	6.09
A66916-1030	18"W x 15"H x 5-3/4"D	7.55	6.80

B Recycled Canvas Zipper Pouch

Made from a blend of recycled cotton fabrics, these pouches are perfect for screen printing, stenciling, and embroidery. They're soft, durable, and perfect for storing personal items or art supplies.

NUMBER	SIZE	EACH	6/EA
A66915-1010	8"W x 5-1/2"H	\$3.94	\$3.55
A66915-1020	10"W x 7" H	4.50	4.05
A66915-1030	5-1/2"W x 4-1/2"H	2.80	2.52
A66915-1040	9-1/4" W x 5"H	3.94	3.55
A66915-1050	8"W x 5-1/4"H	6.77	6.09
A66915-1060	13"W x 9-1/2"H	6.21	5.59

H-I Natural Cotton Bandanas

A great material for tie-dye, fabric paint, iron-on transfers, and other DIY projects. 100% untreated cotton with rolled-hem edges. Made in the USA.

NUMBER	SIZE	EACH	12/EA
A63982-1001	H 22" x 22"	\$2.98	\$2.68
A63982-1002	I 27" x 27"	3.97	3.57

J Natural Cotton Scarf

Dress up this scarf with tie-dye, paint, fabric markers, and more. 100% untreated cotton with rolled-hem edges and fringe on the ends. 20"W x 70"L. Made in the USA.

NUMBER	EACH	12/EA
A63983-1001	\$6.60	\$5.94

K Baseball Caps

Top off your look with a customized hat. These adjustable, blank caps are great for camp, school, and DIY projects. 100% cotton twill. One size fits most, including kids and adults.

NUMBER	COLOR	EACH	12/EA
A44970-1020	White	\$3.22	\$2.90
A44970-2020	Black	3.22	2.90
A44970-3060	K Pink	3.22	2.90

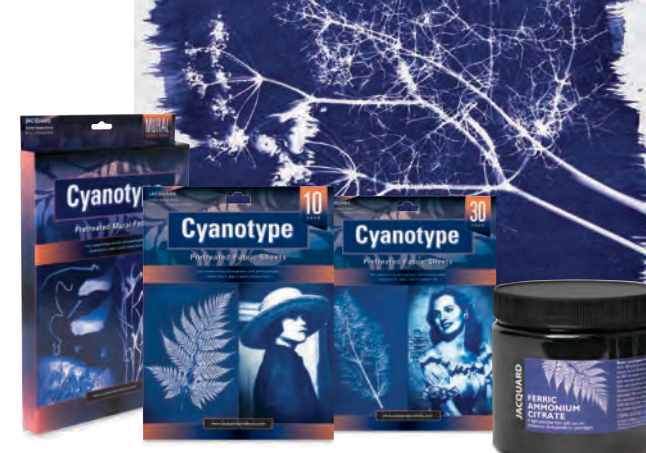

Jacquard' Cyanotype

Create rich, Prussian Blue-colored photographs and photograms on fabric or paper in just minutes. Just place objects or a contact negative over treated paper or fabric and expose to sunlight or another UV light source. Choose from pretreated, ready-to-use cotton sheets, or open stock chemicals, which can be applied to any natural fiber, including paper, cotton, silk, wood, and wool.

Pretreated Fabric Sheets — Cotton sateen fabric sheets measuring 8-1/2" x 11" are pretreated and ready for cyanotype printing. Choose from packages of 10 or 30 sheets.

NUMBER	DESCRIPTION	EACH	6/EA
A01321-1010	10 Sheets	\$28.16	\$25.34
A01321-1030	30 Sheets	\$55.96	\$50.37

Pretreated Fabric Mural — 5 ft x 7 ft cotton sateen.

NUMBER	EACH	3/EA
A01321-1001	\$57.32	\$51.59

Cyanotype Sensitizer Set — Includes the chemicals needed to make approximately 65, 8-1/2" x 11" prints on paper or 50, 8-1/2" x 11" prints on fabric.

NUMBER	EACH	12/EA
A01321-1009	\$14.61	\$13.15

Open Stock Potassium Ferricyanide

NUMBER	SIZE	EACH	12/EA
A01321-1006	8 oz (227 g)	\$18.32	\$16.49
A01321-1011	16 oz (454 g)	26.58	23.94

Open Stock Ferric Ammonium Citrate

NUMBER	SIZE	EACH	12/EA
A01321-1016	8 oz (227 g)	\$22.70	\$20.45
A01321-1021	16 oz (454 g)	41.07	36.98

Class Pack — Contains enough materials for 30 students to make one print each. For full contents, visit DickBlick.com.

NUMBER	EACH	3/EA
A01321-1050	\$106.28	\$95.65



Jacquard' Cotton & Silk Inkjet Fabric Kit

Create fabulous fabric appliques using images from scanned photos, digital cameras, photo CDs, or your desktop inkjet printer. Once printed, peel your design from the backing paper and sew or affix it with fabric glue to quilts, T-shirts, bags, banners, cushions, or any other fabric surface. The print is permanent, lightfast, hand-washable, soft, and supple. The fabric runs through your printer just like paper, retaining its consistency and texture throughout the process. 8-1/2" x 11" sheets.

NUMBER	DESCRIPTION	EACH	12/EA	6/EA
A64929-1000	Cotton, 10-Pack	\$17.58	\$15.82	
A64929-1001	Cotton, 30-Pack	37.52	33.77	
A64929-1002	Silk, 10-Pack	33.39	30.06	
A64929-1003	Silk, 30-Pack	85.79	77.21	



Jacquard' SolarFast

Easily create photographic art prints and one-of-a-kind T-shirts by harnessing the power of sunlight. Simply brush SolarFast onto fabric or paper, place the objects, drawings, or photos on top, expose to sunlight, and watch the color appear — no heat setting or chemical fixing required. The dye leaves fabric soft to the touch.

4 oz (118 ml) Bottles

NUMBER	COLOR	EACH	12/EA
A48933-7064	Avocado	\$9.60	\$8.64
A48933-2024	Black	9.60	8.64
A48933-5014	Blue	9.60	8.64
A48933-8004	Brown	9.60	8.64
A48933-4704	Burnt Orange	9.60	8.64
A48933-4094	Golden Yellow	9.60	8.64
A48933-7034	Green	9.60	8.64
A48933-4514	Orange	9.60	8.64
A48933-5634	Purple	9.60	8.64
A48933-2984	Red	9.60	8.64
A48933-3104	Scarlet	9.60	8.64
A48933-8084	Sepia	9.60	8.64
A48933-5084	Teal	9.60	8.64
A48933-6064	Violet	9.60	8.64

SolarFast Mediums

NUMBER	DESCRIPTION	EACH	12/EA
A48933-1002	Film Pen, Medium Point	\$4.62	\$4.16
A48933-1008	Film, 8-Pack	15.44	13.90
A48933-1003	Thickener, 4 oz (118 ml)	9.89	8.90
A48933-1004	Wash, 4 oz (118 ml)	7.29	6.54

Starter Kit — Make up to eight T-shirts or several dozen paper prints. For details, visit DickBlick.com.

NUMBER	EACH	6/EA
A48933-1001	\$29.74	\$26.78



First-Quality 50/50 White T-Shirts

These T-shirts are made from a comfortable blend of 50% polyester and 50% cotton.

Adult Sizes

NUMBER	SIZE	EACH	12/EA
A44927-1000	Small	\$7.27	\$6.53
A44927-1100	Medium	7.27	6.53
A44927-1200	Large	7.27	6.53
A44927-1300	X-Large	7.27	6.53

Youth Sizes

NUMBER	SIZE	EACH	12/EA
A44959-1040	X-Small 2-4	\$4.53	\$4.07
A44959-1041	Small 6-8	4.53	4.07
A44959-1042	Medium 10-12	4.53	4.07
A44959-1043	Large 14-16	4.53	4.07

First-Quality 50/50 Colored T-Shirts

Make your wearable art more vibrant with these colorful tees. Comfortable and well made, the fabric is a 50/50 blend of cotton and polyester.

COLOR	ADULT SMALL	ADULT MEDIUM	ADULT LARGE	ADULT X-LARGE
Black	A44965-2020	A44965-2021	A44965-2022	A44965-2023
Gray	A44965-2500	A44965-2501	A44965-2502	A44965-2503
Kelly Green	A44965-7010	A44965-7011	A44965-7012	A44965-7013
Navy	A44965-5040	A44965-5041	A44965-5042	A44965-5043
Purple	A44965-6001	A44965-6002	A44965-6003	A44965-6004
Red	A44965-3010	A44965-3011	A44965-3012	A44965-3013
Yellow	A44965-4010	A44965-4011	A44965-4012	A44965-4013

COLOR	EACH	12/EA	EACH	12/EA	EACH	12/EA	EACH	12/EA
Black	\$6.53	\$5.89	\$6.53	\$5.89	\$6.53	\$5.89	\$6.53	\$5.89
Gray								
Kelly Green								
Navy								
Purple								
Red								
Yellow								

COLOR	YOUTH X-SMALL	YOUTH SMALL	YOUTH MEDIUM	YOUTH LARGE
Black	A44959-2020	A44959-2021	A44959-2022	A44959-2023
Gray	A44959-2501	A44959-2502	A44959-2503	A44959-2504
Kelly Green	A44959-7010	A44959-7011	A44959-7012	A44959-7013
Navy	A44959-5040	A44959-5041	A44959-5042	A44959-5043
Purple	A44959-6001	A44959-6002	A44959-6003	A44959-6004
Red	A44959-3010	A44959-3011	A44959-3012	A44959-3013
Yellow	A44959-4010	A44959-4011	A44959-4012	A44959-4013



A-C Tulip One-Step Tie-Dye Kits
Everything you need to make multiple colorful designs. One-step dye powder eliminates the need to presoak fabric in soda ash. Simply add water to the dye bottle, shake, and apply. Vibrant colors stay bold through repeated washings. For best results, use on 100% natural fiber fabrics such as cotton, rayon, and wool.

Ultimate Kit — (not shown) Dye up to 30 projects. Kit includes five squeeze bottles of dye powder, five packets of extra dye powder, eight disposable gloves, 40 rubber bands, and instructions.

NUMBER	EACH	6/EA
A01281-1001	\$20.09	\$18.08



A Tie-Dye Party Kit — Enough supplies for six people and up to 36 projects. Kit includes 18 squeeze bottles of dye powder, six pairs of disposable gloves, six sets of rubber bands, table cover, instructions, all in a reusable plastic storage tub.

NUMBER	EACH	6/EA
A01281-1004	\$27.26	\$24.53

B Neon Kit — Dye up to 30 projects. Kit includes five squeeze bottles of dye powder, five packets of extra dye powder, eight disposable gloves, 40 rubber bands, and instructions.

NUMBER	EACH	6/EA
A01281-1003	\$20.09	\$18.08

C Rainbow Kit — Dye up to 30 projects. Kit includes five squeeze bottles of dye powder, five packets of extra dye powder, eight disposable gloves, 40 rubber bands, and instructions.

NUMBER	EACH	6/EA
A01281-1002	\$20.09	\$18.08



Jacquard Tie Dye Kit

Dye up to 15 adult-size shirts with vivid, electric colors. Red, Yellow, and Blue Procion MX Dyes are pre-measured in plastic squeeze bottles — just add water. Kit also includes an extra mixing bottle, gloves, rubber bands, soda ash dye fixer, and instructions for spirals, stripes, and other designs. For non-synthetic fabrics. Dye is permanent and finished items are wash-fast.

NUMBER	EACH	6/EA
A01301-1009	\$22.25	\$19.99

Jacquard Funky Groovy Tie Dye Kit

Sizzling color and electrifying designs in just three easy steps. This pro-quality kit supplies enough to make five adult-sized T-shirts. Finished projects are colorfast and stay brilliant after repeat washings. Primary-colored Procion MX dye powder is pre-measured and ready to mix with tap water in convenient applicator bottles. Kit also contains gloves, rubber bands, dye fix, and instructions for making spiral, stripe, and geometric patterns.

NUMBER	EACH	6/EA
A64922-1009	\$15.61	\$14.05

Jacquard Droppers

Use these handy plastic droppers for measuring and mixing dye or other liquids. Five per package.

NUMBER	EACH	6/EA
A04958-0000	\$5.42	\$4.87



Jacquard Squeeze Bottles with Tips

These soft 0.5 oz (15 ml) plastic applicator squeeze bottles can be used for fine detail with fabric paints, resist, glues, ceramics, candy making, cake decoration, model making, and miniatures. Set of three bottles and three stainless steel tips — 0.5 mm, 0.7 mm, and 0.9 mm.

NUMBER	EACH	6/EA
A04958-1000	\$11.89	\$10.69



Mix colors to make your own custom shades!

Rit Liquid Dye

For fun techniques like tie-dyeing, dip-dyeing, shibori, and ombré effects. Works with cotton, linen, silk, wool, and more. One bottle colors 2 lb of fabric (about 6 yards). Non-toxic.

NUMBER	COLOR	EACH	12/EA
A01273-7175	Apple Green	\$5.50	\$4.95
A01273-5365	Aquamarine	5.50	4.95
A01273-2025	Black	5.50	4.95
A01273-8715	Camel	5.50	4.95
A01273-2135	Charcoal Grey	5.50	4.95
A01273-3455	Cherry Red	5.50	4.95
A01273-8365	Cocoa Brown	5.50	4.95

NUMBER	COLOR	EACH	12/EA
A01273-3245	Coral	\$5.50	\$4.95
A01273-8035	Dark Brown	5.50	4.95
A01273-7035	Dark Green	5.50	4.95
A01273-5915	Denim Blue	5.50	4.95
A01273-6145	Eggplant	5.50	4.95
A01273-7055	Emerald	5.50	4.95
A01273-5455	Evening Blue	5.50	4.95
A01273-3755	Fuchsia	5.50	4.95
A01273-4095	Golden Yellow	5.50	4.95
A01273-1005	Hyacinth	5.50	4.95
A01273-5205	Indigo	5.50	4.95
A01273-7365	Kelly Green	5.50	4.95
A01273-4065	Lemon Yellow	5.50	4.95
A01273-5045	Navy Blue	5.50	4.95
A01273-7775	Neon Green	5.50	4.95
A01273-4855	Neon Yellow	5.50	4.95
A01273-2405	Pearl Grey	5.50	4.95
A01273-3705	Petal Pink	5.50	4.95
A01273-6005	Purple	5.50	4.95
A01273-3745	Rose Quartz	5.50	4.95
A01273-5055	Royal Blue	5.50	4.95
A01273-3085	Scarlet	5.50	4.95
A01273-4805	Sunshine Orange	5.50	4.95
A01273-8235	Tan	5.50	4.95
A01273-4635	Tangerine	5.50	4.95
A01273-8305	Taupe	5.50	4.95
A01273-5085	Teal	5.50	4.95
A01273-7425	Truly Green	5.50	4.95
A01273-6515	Violet	5.50	4.95
A01273-3725	Wine	5.50	4.95

NUMBER	DESCRIPTION	EACH	12/EA
A01273-1003	Color Stay Dye Fixative	\$5.50	\$4.95
A01273-1001	Whitener & Brightener	5.50	4.95



Rit Dye Powder

Great for ice dyeing and other techniques. Use it to color almost any porous surface, including fabrics, wood, and wicker. One box colors 1 lb of fabric (about 3 yards). Non-toxic.

NUMBER	COLOR	EACH	12/EA
A01257-2020	Black	\$3.38	\$3.03
A01257-8360	Cocoa Brown	3.38	3.03
A01257-8030	Dark Brown	3.38	3.03
A01257-7030	Dark Green	3.38	3.03
A01257-5910	Denim Blue	3.38	3.03
A01257-3750	Fuchsia	3.38	3.03
A01257-4090	Golden Yellow	3.38	3.03
A01257-7360	Kelly Green	3.38	3.03
A01257-4920	Lemon Yellow	3.38	3.03
A01257-5040	Navy Blue	3.38	3.03
A01257-2400	Pearl Grey	3.38	3.03
A01257-3620	Petal Pink	3.38	3.03
A01257-6000	Purple	3.38	3.03
A01257-5050	Royal Blue	3.38	3.03

NUMBER	COLOR	EACH	12/EA
A01257-3080	Scarlet	\$3.38	\$3.03
A01257-4630	Tangerine	3.38	3.03
A01257-5080	Teal	3.38	3.03
A01257-3720	Wine	3.38	3.03

NUMBER	DESCRIPTION	EACH	12/EA
A01257-1001	Color Remover	\$3.38	\$3.03
A01257-1003	SunGuard™	4.08	3.67
A01257-1792	White-Wash®	3.38	3.03
A01257-1002	Whitener & Brightener	3.38	3.03

RIT



Jacquard Indigo Dye Kit

Used by cultures around the world, the indigo dye process makes it easy to create wonderful resist patterns on fabric. Try the natural and ancient art with this user-friendly formulation. The kit dyes the equivalent of 15 yards of fabric, five pounds of fabric, or 15 shirts. Use it with natural fabrics or clothing only. Suitable for use by all ages, with adult supervision of younger children.

NUMBER	EACH	6/EA
A01301-1109	\$15.27	\$13.75

Plastibands

The better alternative to rubber bands for any art or craft project. The latex-free material is stronger than rubber and won't deteriorate. Great for tie-dyeing and batik. In assorted colors that won't bleed. Available in two sizes.

NUMBER	DESCRIPTION	EACH	10/EA
A61411-1002	2" Box of 200	\$8.47	\$7.62
A61411-1004	4" Box of 100	10.99	9.90



Arts & Crafts Display Line with Clips

A perfect way to display artwork and photos, or dry fabrics and paintings. 30 ft cord includes 16 pre-attached plastic-coated spring clips that won't slip or damage paper and cloth.

NUMBER	DESCRIPTION	EACH	10/EA
A04983-1010	Display Line with Clips	\$17.58	\$15.83
A04983-1020	Extra Clips, Pkg of 25	9.91	8.92

Push Pins

Aluminum heads with sharp stainless steel points make these push pins perfect for tacking fabric to wooden stretcher frames. Won't rust or leave large holes in fabric. 100 pins per box.

NUMBER	EACH	9/EA
A64916-0100	\$21.57	\$19.40

The Super Tub

Versatile tub for a number of projects, including etching, paper making, and fabric dyeing. Made of durable, heavy-duty black plastic. 8" deep. Bottom measures 30" x 22".

NUMBER	EACH	3/EA
A46904-0000	\$30.38	\$27.34



Gojo Waterless Orange Cleaner

Gojo is the natural, economical way to remove artistic soils, dirt, and grease with or without water. Quick acting for ground-in dirt. USDA E4 Classification. Gallon (3.78 liter).

NUMBER	DESCRIPTION	EACH	4/EA
A02980-1009	Smooth	\$36.65	\$32.99
A02980-1019	Pumice	36.65	32.99

Perfect for cosplay!



Rit DyeMore Synthetic Fiber Dye

Add custom color to 100% polyester and polyester blends, nylon, acetate, acrylic, and even some plastics. You can also use it to dye wigs for cosplay and costume projects. Non-toxic and easy to use.

NUMBER	COLOR	EACH	12/EA
A01272-3100	Apricot Orange	\$5.65	\$5.08
A01272-8100	Chocolate Brown	5.65	5.08
A01272-4480	Daffodil Yellow	5.65	5.08
A01272-2500	Frost Grey	5.65	5.08
A01272-2190	Graphite	5.65	5.08
A01272-5070	Kentucky Sky	5.65	5.08
A01272-5040	Midnight Navy	5.65	5.08
A01272-7530	Peacock Green	5.65	5.08
A01272-3910	Racing Red	5.65	5.08
A01272-6410	Royal Purple	5.65	5.08
A01272-8920	Sand Stone	5.65	5.08
A01272-5020	Sapphire Blue	5.65	5.08
A01272-3730	Super Pink	5.65	5.08
A01272-5080	Tropical Teal	5.65	5.08



Jacquard Procion MX Fiber-Reactive Cold Water Dye

When mixed with soda ash, Procion MX dyes are permanent, colorfast, and very washable. The cold water dyes don't require heat, making them great for tie-dye, batik, airbrush, screen printing, spatter painting, and much more. Perfect for all natural fibers — cotton, linen, paper, and reeds (not suitable for synthetics). A detailed instruction sheet is available upon request.

Colors can be assorted for quantity pricing. 0.66 oz (19 ml) Bottles

NUMBER	COLOR	EACH	6/EA
A01302-4572	Antique Gold	\$5.25	\$4.70
A01302-5362	Aquamarine	5.25	4.70
A01302-7462	Avocado	5.25	4.70
A01302-5482	Bright Blue	5.25	4.70
A01302-4922	Bright Golden Ylw	5.25	4.70
A01302-7252	Bright Green	5.25	4.70
A01302-3712	Bright Scarlet	5.25	4.70
A01302-4592	Brilliant Orange	5.25	4.70
A01302-8152	Bronze	5.25	4.70
A01302-8912	Brown Rose	5.25	4.70
A01302-3722	Bubble Gum	5.25	4.70
A01302-3142	Burgundy	5.25	4.70
A01302-3152	Carmine Red	5.25	4.70
A01302-5162	Cerulean Blue	5.25	4.70
A01302-8102	Chocolate Brown	5.25	4.70
A01302-5182	Cobalt Blue	5.25	4.70
A01302-6122	Deep Purple	5.25	4.70
A01302-1452	Ecru	5.25	4.70
A01302-7052	Emerald Green	5.25	4.70
A01302-3732	Fire Engine Red	5.25	4.70
A01302-7272	Forest Green	5.25	4.70
A01302-6132	Fuchsia	5.25	4.70
A01302-3292	Hot Pink	5.25	4.70
A01302-5562	Ice Blue	5.25	4.70
A01302-2032	Jet Black	5.25	4.70
A01302-4062	Lemon Yellow	5.25	4.70
A01302-6032	Lilac	5.25	4.70
A01302-3042	Magenta	5.25	4.70
A01302-6912	Marine Violet	5.25	4.70
A01302-5022	Medium Blue	5.25	4.70
A01302-5802	Midnight Blue	5.25	4.70
A01302-5042	Navy	5.25	4.70
A01302-2542	Neutral Gray	5.25	4.70
A01302-7072	Olive Green	5.25	4.70
A01302-5912	Pale Aqua	5.25	4.70
A01302-3352	Peach	5.25	4.70
A01302-3362	Raspberry	5.25	4.70
A01302-5322	Robin's Egg	5.25	4.70
A01302-4912	Rust Orange	5.25	4.70
A01302-5082	Teal	5.25	4.70
A01302-5112	Turquoise	5.25	4.70
A01302-6512	Violet	5.25	4.70
A01302-2282	Warm Black	5.25	4.70



Jacquard iDye

Dyeing fabric in a washing machine has never been easier! iDye's self-dissolving packet eliminates the handling of messy powders. 30 vibrant colors for 100% natural fabrics (cotton, silk, rayon, wool, and linen); 16 colors for polyester and nylon. Mix the two for synthetic blends. Use Color Remover to remove or lighten colors and brighten whites. Sun Blocker makes fabrics UV-resistant. One 0.5 oz package dyes 2-3 lb of fabric. A hot water dye. Colors can be assorted for quantity pricing.

iDye for Natural Fabrics, 0.5 oz (14 g) Packets

NUMBER	COLOR	EACH	6/EA
A01312-9010	Aztec Gold	\$4.56	\$4.10
A01312-2020	Black	4.56	4.10
A01312-4290	Bright Yellow	4.56	4.10
A01312-5010	Brilliant Blue	4.56	4.10
A01312-8010	Brown	4.56	4.10
A01312-4310	Chartreuse	4.56	4.10
A01312-8250	Chestnut	4.56	4.10
A01312-3160	Crimson	4.56	4.10
A01312-4590	Deep Orange	4.56	4.10
A01312-1450	Ecru	4.56	4.10
A01312-7050	Emerald	4.56	4.10
A01312-3120	Fire Red	4.56	4.10
A01312-4220	Fluorescent Ylw	4.56	4.10
A01312-9030	Gold Ochre	4.56	4.10
A01312-4060	Golden Yellow	4.56	4.10
A01312-2610	Gun Metal	4.56	4.10
A01312-7360	Kelly Green	4.56	4.10
A01312-6030	Lilac	4.56	4.10
A01312-5070	Navy	4.56	4.10
A01312-7070	Olive	4.56	4.10
A01312-3060	Pink	4.56	4.10
A01312-4620	Pumpkin	4.56	4.10
A01312-6000	Purple	4.56	4.10
A01312-5050	Royal Blue	4.56	4.10
A01312-3080	Scarlet	4.56	4.10
A01312-2590	Silver Gray	4.56	4.10
A01312-4400	Sun Yellow	4.56	4.10
A01312-3710	True Red	4.56	4.10
A01312-5110	Turquoise	4.56	4.10
A01312-6510	Violet	4.56	4.10

iDye for Polyester/Nylon, 0.5 oz (14 g) Packets

NUMBER	COLOR	EACH	6/EA
A01312-2000	Black	\$4.56	\$4.10
A01312-5000	Blue	4.56	4.10
A01312-8000	Brown	4.56	4.10
A01312-3164	Crimson	4.56	4.10
A01312-4294	Golden Yellow	4.56	4.10
A01312-7000	Green	4.56	4.10
A01312-2614	Gun Metal	4.56	4.10
A01312-7364	Kelly Green	4.56	4.10
A01312-6034	Lilac	4.56	4.10
A01312-4500	Orange	4.56	4.10
A01312-3064	Pink	4.56	4.10
A01312-3000	Red	4.56	4.10
A01312-2624	Silver Gray	4.56	4.10
A01312-5114	Turquoise	4.56	4.10
A01312-6500	Violet	4.56	4.10
A01312-4000	Yellow	4.56	4.10

iDye Mediums, 0.5 oz (14 g) Packets

NUMBER	COLOR	EACH	6/EA
A01312-1001	Color Remover	\$4.56	\$4.10
A01312-1014	Fixative	4.56	4.10



Jacquard Materials Needed for Fabric Dyeing with Procion Dyes

Soda Ash makes colors permanent. Urea is a color enhancer. Synthrapol is a liquid detergent.

NUMBER	DESCRIPTION	EACH	6/EA
A01302-1016	Soda Ash, 1 lb (454 g)	\$3.86	\$3.47
A01302-1005	Soda Ash, 5 lb (2.26 kg)	14.10	12.69
A01302-1026	Urea, 1 lb (454 g)	3.86	3.47
A01302-1015	Synthrapol, 6 oz (177 ml)	9.99	8.99
A01302-1006	Plastic Bottle, 16 oz (473 ml)	1.91	1.72

JACQUARD

Jacquard Textile Colors

These versatile colors are ready for direct application with brush, stamp, squirt bottle, or airbrush — no special techniques required. Used straight from the bottle, the colors are intense and semi-opaque. When diluted with water (or the Colorless Extender), they assume qualities of the best watercolors. Absolutely colorfast on both natural and synthetic fabrics. All colors are blendable. Colors can be assorted for quantity pricing.

COLOR	2.25 OZ (67 ML)	8 OZ (237 ML)
Apple Green	A01208-7174	A01208-7175
Black	A01208-2004	A01208-2005
Brown	A01208-8004	A01208-8005
Brown Ochre	A01208-8384	—
Burnt Sienna	A01208-8044	—
Burnt Umber	A01208-8054	—
Colorless Extender	A01208-1414	A01208-1001
Emerald Green	A01208-7054	A01208-7055
Fluorescent Blue	A01208-5244	A01208-5245
Fluorescent Green	A01208-7264	A01208-7265
Fluorescent Orange	A01208-4554	A01208-4555
Fluorescent Pink	A01208-3474	A01208-3475
Fluorescent Red	A01208-3214	A01208-3215
Fluorescent Violet	A01208-6913	A01208-6915
Fluorescent Yellow	A01208-4214	A01208-4215
Goldenrod	A01208-4694	A01208-4695
Maroon	A01208-3344	A01208-3345
Mars Red	A01208-3804	—
Navy Blue	A01208-5044	A01208-5045
Neutral Gray	A01208-2544	—
Olive Green	A01208-7074	A01208-7075
Opaque White	A01208-1074	A01208-1075
Orange	A01208-4504	A01208-4505
Periwinkle	A01208-5772	A01208-5775
Pink	A01208-3054	A01208-3065
Raw Sienna	A01208-8064	—
Raw Umber	A01208-8074	—
Ruby Red	A01208-3374	A01208-3375
Russet	A01208-3513	A01208-3515
Sapphire Blue	A01208-5294	A01208-5295
Scarlet Red	A01208-3084	A01208-3085
Sky Blue	A01208-5074	A01208-5075
Spruce	A01208-7912	A01208-7915
Terre Verte	A01208-7134	—
True Red	A01208-3714	A01208-3715
Turquoise	A01208-5114	A01208-5115
Violet	A01208-6504	A01208-6505
White	A01208-1004	A01208-1005
Yellow	A01208-4004	A01208-4005
Yellow Ochre	A01208-4042	A01208-4045

Jacquard Textile Color Sets

Set of 8 — Yellow, Orange, True Red, Violet, Sapphire Blue, Emerald Green, Black, and White in 2.25 oz (67 ml) jars.

NUMBER	EACH	6/EA
A01208-1009	\$33.46	\$30.11

Set of 6 — Yellow, True Red, Navy Blue, Emerald Green, Black, and White in 8 oz (237 ml) jars.

NUMBER	EACH	6/EA
A01247-1009	\$90.29	\$81.26

Earth Tones Set of 8 — Raw Sienna, Burnt Sienna, Mars Red, Raw Umber, Burnt Umber, Brown Ochre, Terre Verte, and Neutral Gray in 2.25 oz (67 ml) jars.

NUMBER	EACH	6/EA
A01208-1089	\$33.46	\$30.11



Marabu Easy Marble Paints

Create striking marble effects in just seconds. Designed to cover everything from plastic to wood, Easy Marble paints are lightfast and quick-drying. They work particularly well on 3-D objects, including candles and decorative eggs. Just drip the colors into water, dip your item, and you're done! You'll get a new, surprising marble design every time. 15 ml bottles. Colors can be assorted for quantity pricing.

NUMBER	COLOR	EACH	6/EA
A63412-3711	Amethyst	\$3.38	\$3.05
A63412-7111	Aqua Green	3.38	3.05
A63412-7131	Aubergine	3.38	3.05
A63412-5911	Azure Blue	3.38	3.05
A63412-2021	Black	3.38	3.05
A63412-3451	Cherry Red	3.38	3.05
A63412-1601	Crystal Clear	3.38	3.05
A63412-5341	Dark Ultramarine	3.38	3.05
A63412-9011	Gold	3.38	3.05
A63412-6041	Lavender	3.38	3.05
A63412-4061	Lemon	3.38	3.05
A63412-4061	Light Blue	3.38	3.05
A63412-7011	Light Green	3.38	3.05
A63412-4021	Med Yellow	3.38	3.05
A63412-4511	Orange	3.38	3.05
A63412-7931	Reseda	3.38	3.05
A63412-7041	Rich Green	3.38	3.05
A63412-3661	Rose Pink	3.38	3.05
A63412-3371	Ruby Red	3.38	3.05
A63412-9331	Silver	3.38	3.05
A63412-5111	Turquoise	3.38	3.05
A63412-1021	White	3.38	3.05

Starter Set — Includes six 15 ml bottles of marble paint in classic colors and an instructional brochure.

NUMBER	EACH	6/EA
A63412-1009	\$15.65	\$14.09



Tulip Dimensional Fabric Paint Sets

Get creative in 3-D! This permanent paint is formulated for lasting adhesion to fabric, so designs stay dimensional and won't crack or peel. Each set includes six 1.25 oz (37 ml) bottles of premium-quality, non-toxic fabric paint.

Glow, Set of 6 — These luminous colors have a glow-in-the-dark finish.

NUMBER	EACH	12/EA
A01283-1029	\$9.85	\$8.86

Neon, Set of 6 — These colors are super bold and vibrant.

NUMBER	EACH	12/EA
A01283-1009	\$9.85	\$8.86

Slick, Set of 6 — These vibrant colors have a super shiny finish.

NUMBER	EACH	12/EA
A01283-1019	\$11.18	\$10.06

MARABU

Marabu Fashion Spray

Create wearable art! This waterbased fabric paint comes in spray bottles with high-quality pumps for easy application — all you need is light-colored fabric and an idea. Try it on clothes, bags, pillowcases, and more. Paint is odorless and non-fading. When dry, it's soft to the touch. 3.4 oz (100 ml) bottles. Colors can be assorted for quantity pricing.

NUMBER	COLOR	EACH	6/EA
A63413-7171	Apple	\$6.06	\$5.45
A63413-7131	Aubergine	6.06	5.45
A63413-2021	Black	6.06	5.45
A63413-3721	Bordeaux	6.06	5.45
A63413-5911	Caribbean	6.06	5.45
A63413-8361	Cocoa	6.06	5.45
A63413-4911	Flamingo	6.06	5.45
A63413-2591	Grey	6.06	5.45
A63413-4061	Lemon	6.06	5.45
A63413-5551	Marine Blue	6.06	5.45
A63413-7511	Mint	6.06	5.45
A63413-5801	Night Blue	6.06	5.45
A63413-5921	Petrol	6.06	5.45
A63413-3061	Pink	6.06	5.45
A63413-6171	Plum	6.06	5.45
A63413-3361	Raspberry	6.06	5.45
A63413-3011	Red	6.06	5.45
A63413-3381	Red Orange	6.06	5.45
A63413-7931	Reseda	6.06	5.45
A63413-5071	Sky Blue	6.06	5.45
A63413-4391	Sunshine Yellow	6.06	5.45
A63413-4631	Tangerine	6.06	5.45

Cool Denim Set — Includes 3.4 oz (100 ml) bottles of Marine Blue, Reseda, and Sky Blue and one 0.85 oz (25 ml) Fashion Liner in Shimmer Silver.

NUMBER	EACH	6/EA
A63413-5919	\$18.20	\$16.38

Tropical Island Set — Includes 3.4 oz (100 ml) bottles of Apple, Pink, and Plum and one 0.85 oz (25 ml) Fashion Liner in Shimmer Reseda.

NUMBER	EACH	6/EA
A63413-7919	\$18.20	\$16.38

Tulip ColorShot Instant Fabric Color Spray

This spray paint for

JACQUARD



Jacquard' Dye-Na-Flow

Highly concentrated, translucent colors. Dye-Na-Flow is a free-flowing textile paint made to simulate dye. Incredibly versatile, it's perfect for silk painting, airbrushing, tie-dyeing, or simplified batik techniques. Or apply it with a brush or sponge. Great on any untreated natural or synthetic fiber. Requires heat-setting with iron or clothes dryer. Not suitable for marbling.

Colors can be assorted for quantity pricing.

COLOR	2.25 OZ (67 ML)	8 OZ (237 ML)
Azure Blue	A01218-5913	A01218-5910
Black	A01218-2023	A01218-2020
Brass	A01218-8163	A01218-8160
Brick	A01218-3703	A01218-3700
Bright Green	A01218-7253	A01218-7250
Bright Orange	A01218-4503	A01218-4500
Brilliant Red	A01218-3723	A01218-3720
Brown	A01218-8003	A01218-8000
Burnt Umber	A01218-8053	A01218-8050
Cerulean Blue	A01218-5163	A01218-5160
Chartreuse	A01218-7633	A01218-7630
Claret	A01218-3003	A01218-3000
Cranberry Red	A01218-3713	A01218-3710
Ecu	A01218-1453	A01218-1450
Emerald Green	A01218-7053	A01218-7050
Golden Yellow	A01218-4083	A01218-4080
Hot Fuchsia	A01218-3753	A01218-3750
Magenta	A01218-3043	A01218-3040
Midnight Blue	A01218-5803	A01218-5800
Ochre	A01218-4043	A01218-4040
Periwinkle	A01218-5773	A01218-5770
Pewter	A01218-2573	A01218-2570
Salmon	A01218-3513	A01218-3510
Scarlet	A01218-3083	A01218-3080
Sulphur Green	A01218-7003	A01218-7000
Sun Yellow	A01218-4913	A01218-4910
Teal	A01218-5083	A01218-5080
Turquoise	A01218-5113	A01218-5110
Violet	A01218-6503	A01218-6500
White	A01218-1013	A01218-1010

	EACH	12/EA	EACH	6/EA
	\$4.68	\$4.15	\$15.39	\$13.87

Jacquard' Silk Dyes

True dyes — not thinned pigment — these intense, rich, translucent colors will not stiffen silk or mask its natural luster. May be blended directly on fabric or intermixed separately to create an infinite range of colors. Dilute with water for softer shades. Dyes are lightfast, odorless, non-toxic, and can be hand washed or dry cleaned. Colors can be assorted for quantity pricing.

2 oz (59 ml) Bottles

NUMBER	COLOR	EACH	6/EA
A01234-4583	Apricot	\$4.59	\$4.12
A01234-2023	Black	4.59	4.12
A01234-8123	Brown Sienna	4.59	4.12
A01234-3153	Carmine Red	4.59	4.12
A01234-8103	Chocolate Brown	4.59	4.12
A01234-4673	Citron	4.59	4.12
A01234-5593	Cyan	4.59	4.12
A01234-6013	Digital	4.59	4.12
A01234-7363	Kelly Green	4.59	4.12
A01234-3043	Magenta	4.59	4.12
A01234-7813	Marine Green	4.59	4.12
A01234-5003	Night Blue	4.59	4.12
A01234-3613	Poppy Red	4.59	4.12
A01234-6003	Purple	4.59	4.12
A01234-5053	Royal Blue	4.59	4.12
A01234-5293	Sapphire Blue	4.59	4.12
A01234-3083	Scarlet Red	4.59	4.12
A01234-5113	Turquoise	4.59	4.12
A01234-7103	Viridian Green	4.59	4.12
A01234-4003	Yellow	4.59	4.12



Jacquard' Waterbased Resist

This superior resist has a smooth consistency that holds a crisp line without spreading. It won't shrink or pucker when dry. Screenable, odorless, and non-toxic.

Permanent Resists — After being heat set with an iron, these colored and metallic resists are completely permanent whether washed or dry cleaned. Can be applied with a squeeze bottle. 2.25 oz (67 ml) jars.

NUMBER	COLOR	EACH	6/EA
A01231-2024	Black	\$5.70	\$5.15
A01231-9004	Gold	5.70	5.15
A01231-9334	Silver	5.70	5.15

Removable Resist — This white resist easily washes out with warm water, revealing the white or colored silk beneath. Keeps silk soft to the touch and allows for layered designs such as batik. Tint it with any waterbased dye for colored lines. Alcohol-free.

NUMBER	SIZE	EACH	6/EA
A01231-1604	2 oz (60 ml)	\$4.54	\$4.08
A01231-1605	8 oz (237 ml)	10.90	9.81

Jacquard' Dye-Na-Flow' Set of 8

Includes one each of Azure Blue, Black, Bright Orange, Brilliant Red, Emerald Green, Sun Yellow, Violet, and White in 2.25 oz (67 ml) bottles.

NUMBER	EACH	6/EA
A01218-1009	\$31.87	\$28.68



Jacquard' Silk Hoops Class Kit

This kit was put together for classroom use as an excellent way to introduce students of all ages to the beauty of painting on silk with dye. Kit contains: 30, 9-1/2" diameter metal hoops stretched with Chinese silk, five 2 oz (60 ml) bottles of silk paint (Red, Yellow, Blue, Brown Sienna, and Black), 8 oz (237 ml) waterbased resist, puff crystal salt, six resist applicator bottles, six #7 applicator tips, 30 small brushes, and instructions.

NUMBER	EACH
A01240-1029	\$264.59



Jacquard' Silk Hoops Fun Bag Kit

Perfect for beginners, the Fun Bag provides a great way to try several silk painting techniques in one kit. Includes three 9-1/2" diameter silk hoops, three Dye-Na-Flow colors, Gold waterbased resist, two brushes, and silk salt.

NUMBER	EACH	12/EA
A01240-1019	\$30.51	\$27.44

Refill Silk Hoops — 100% Chinese silk stretched over 9-1/2" diameter metal hoops.

NUMBER	DESCRIPTION	EACH	3/EA
A63005-1003	Pkg of 3	\$18.04	\$16.23
A63005-1030	Pkg of 30	155.84	140.28



Tjanting Tools

Tools for applying wax in fine lines. Hot wax is poured into needle, flows through needle spout. Tip forward to start wax flow, tip back to stop.

NUMBER	DESCRIPTION	EACH	6/EA
A64904-0200	Small	\$5.65	\$5.03
A64904-0100	Medium	5.65	5.03
A64904-0000	Large	5.65	5.03

Set of 3 — One of each size.

NUMBER	EACH	6/EA
A64913-1009	\$13.13	\$11.81



Kemper' Fluid Writer Pen

Ideal tool for fabric painting, drawings, signing artwork, making perfectly consistent dots, line art, and French matting. Use with acrylic paints, watercolors, oils, or ink.

NUMBER	DESCRIPTION	EACH	12/EA
A64911-0100	Thin Line	\$17.63	\$15.89
A64911-0000	Thick Line	18.19	16.37



Batik Funnel Pen

Wax funnel pen with pencil-type soldering iron. Melts candles, crayons, batik wax, and paraffin to produce a controlled thick or thin line.

NUMBER	EACH
A64906-0000	\$62.53



For more Batik supplies, visit DickBlick.com.



Wax Melter Kit

A simple way to melt wax for batik, crayon painting, candle decorating, ceramic resist, jewelry, sculpture, and lapidary work. Kit includes palette, removable cups, and squeeze pen, all aluminum. Squeeze pen is useful for controlled thin to thick lines.

NUMBER	EACH	6/EA
A64902-1009	\$60.75	\$51.63

Squeeze Pen Only — Package of 10.

NUMBER	EACH	6/EA
A64902-1000	\$45.55	\$38.72



Tulip' Dual-Tip Fabric Markers

These easy-to-use fabric markers deliver vivid, permanent color. Each marker has two tips — a brush tip for broad coverage, and an extra-fine tip for writing, doodling, and detailed designs. The ink is non-toxic and machine washable. No heat setting required.

NUMBER	EACH	12/EA
A01279-1014	\$19.19	\$17.27



Jacquard' Batik Wax

This professional-quality wax is a specially formulated 75/25 blend of paraffin and beeswax. The beeswax tempers the paraffin for better adhesion to fabric and less brittleness than paraffin alone. The blend provides better control over the distinctive crackle effect of traditional batik and is less expensive than beeswax.

NUMBER	SIZE	EACH	10/EA
A01200-1001	1 lb (473 ml) Tin	\$23.49	\$21.15



Tulip' Opaque Bullet Tip Fabric Markers

Personalize any dark or light fabric surface. These markers deliver intense, opaque color. Their bullet tip is great for doodling, stenciling, coloring, and writing. Non-toxic, machine washable ink. It's permanent on fabric when heat-set.

NUMBER	DESCRIPTION	EACH	12/EA
A01280-1019	A Set of 6 Bright	\$12.15	\$10.91
A01280-1009	B Set of 6 Primary	12.15	10.91
A01280-1029	C Rainbow Set of 15	24.89	22.39

Silk Scarves

Smooth-textured habutai scarves are made from 100% Chinese silk and ready to paint or dye. Color shows vibrantly. Hand-rolled and hemmed with silk thread so all fabric dyes evenly.

NUMBER	SIZE	EACH	12/EA
A63000-1022	22" x 22"	\$12.35	\$11.11
A63000-1035	35" x 35"	16.69	14.99
A63000-1072	14" x 72"	21.12	18.99



Jacquard' Silk Salt

Sprinkle puffed crystal salt on wet, dyed fabric to create exciting effects. The salt absorbs the dye as it dries, leaving a textured halo look. Works best with medium- and dark-colored dyes.

NUMBER	SIZE	EACH	6/EA
A01233-1002	2 oz (60 ml)	\$2.61	\$2.34
A01233-1010	10 oz (300 ml)	5.24	4.70



Jacquard' Beeswax

This pure yellow refined beeswax is ideal for batik and other crafts. Beeswax is flexible and produces less cracking in batik applications.

NUMBER	SIZE	EACH	6/EA
A64924-1001	1 lb (454 g) Block	\$25.17	\$22.65



Tulip' Color Me Totes

Fill in the pre-printed designs on these canvas totes with fabric markers and fabric paints. Or, choose the Blank tote and create unique illustrations to make it your own.

NUMBER	DESCRIPTION	EACH	12/EA
A64938-1005	Blank	\$5.25	\$4.73
A64938-1003	Elephant, short handle	5.25	4.73
A64938-1001	Life is Better	5.25	4.73
A64938-1004	Mandala	5.25	4.73
A64938-1002	Skull	5.25	4.73



NEW! Tulip Graffiti Fabric Markers

Create bold designs and word art on a variety of different fabric items. Markers are safe for all ages, so even young ones can have fun decorating and customizing their own shirts, backpacks, shoes, hats, and more. The inks are permanent without heat setting and fade-resistant, even after multiple washing. Non-toxic.

Dual Tip Set of 6

NUMBER	COLOR	EACH	12/EA
A02822-1001	Neon	\$9.80	\$8.79

Chisel Tip Sets of 6

NUMBER	COLOR	EACH	12/EA
A64955-1002	Bright	\$7.03	\$6.33
A64955-1003	Neon	7.03	6.33
A64955-1001	Rainbow	7.03	6.33

Bullet Tip Sets of 6

NUMBER	COLOR	EACH	12/EA
A64954-1004	Bright	\$7.49	\$6.73
A64954-1003	Neon	7.49	6.73
A64954-1002	Rainbow	7.49	6.73



Bullet Tip Set of 30

NUMBER	COLOR	EACH	12/EA
A64954-1001	Rainbow	\$26.99	\$24.29



Stained by Sharpie® Brush Tip Fabric Marker Sets

Bright, bold colors, perfect for staining your stuff! Wash your decorated items without worry. The ink resists fading on most fabrics.

Set of 8 — Black, Blue, Red, Green, Pink, Orange, Purple, and Yellow.

NUMBER	EACH	6/EA
A01250-1008	\$24.57	\$22.10



Yasutomo® FabricMate® DYE Ink Brush Tip Markers

Pigment-based fabric dye in a pen form.

Available in a variety of bright, odorless colors that mix well for endless color combinations. The dye is permanent when dry, so it won't wash out with repeated laundering. Non-toxic.

NUMBER	COLOR	EACH	12/EA
A01202-3062	Alizarin Crimson	\$2.55	\$2.30
A01202-2002	Black	2.55	2.30
A01202-5002	Blue	2.55	2.30
A01202-5182	Cobalt Blue	2.55	2.30
A01202-4692	Fluorescent Orange	2.55	2.30
A01202-2622	Gray	2.55	2.30
A01202-7232	Lime Squeeze	2.55	2.30
A01202-3042	Magenta	2.55	2.30
A01202-5802	Midnight Blue	2.55	2.30
A01202-3632	Neon Pink	2.55	2.30
A01202-4502	Orange	2.55	2.30
A01202-6422	Orchid	2.55	2.30
A01202-7842	Sea Green	2.55	2.30
A01202-3712	Strawberry	2.55	2.30
A01202-5112	Turquoise	2.55	2.30
A01202-6502	Violet	2.55	2.30
A01202-4002	Yellow	2.55	2.30
A01202-0000	Blender Brush	2.55	2.30

Designer Colors Set of 6 — Black, Crimson, Cobalt, Ochre, Peach, and Viridian.

NUMBER	EACH	6/EA
A01202-0069	\$15.32	\$13.81

Fluorescent Colors Set of 6 — Neon Green, Yellow, Orange, Pink, Purple, and Blue.

NUMBER	EACH	6/EA
A01202-0079	\$15.32	\$13.81

Pastel Colors Set of 6 — Strawberry, Coral, Aqua, Mist Gray, Lavender, and Tan.

NUMBER	EACH	6/EA
A01202-0089	\$15.32	\$13.81

Standard Colors Set of 6 — Orange, Red, Blue, Green, Brown, and Black.

NUMBER	EACH	6/EA
A01202-0099	\$15.32	\$13.81

Tropical Colors Set of 6 — Apple Green, Gray, Lemon Yellow, Magenta, Purple, and Turquoise.

NUMBER	EACH	6/EA
A01202-0109	\$15.32	\$13.81



Crayola® Fabric Marker Sets

Fabric markers in a variety of brilliant colors are a safe, easy way to add unique style to clothing and accessories. Simply apply the marker ink to cotton or polyester fabrics, then toss the garments in a clothes dryer to heat-set the design. For ages 4 and up.

Fine Line Set of 10 — Black, Blue, Gray, Lime, Pink, Red, Teal, Orange, Lavender, and Yellow.

NUMBER	EACH	12/EA
A21259-1010	\$6.98	\$6.28

Primary Classpack® of 80 — Eight each of Black, Blue, Gray, Lime, Pink, Red, Teal, Orange, Lavender, and Yellow.

NUMBER	EACH	3/EA
A21259-1809	\$50.55	\$45.50



Marvy® Uchida DecoFabric Fabric Markers

Great on both dark and light fabrics, these markers have 3 mm bullet-point tips for writing and drawing details. Odorless, lightfast, and acid-free. Heat setting recommended.

NUMBER	COLOR	EACH	6/EA
A01227-2010	Black	\$3.87	\$3.49
A01227-5010	Blue	3.87	3.49
A01227-8010	Brown	3.87	3.49
A01227-8090	Copper	3.87	3.49
A01227-9330	Gold	3.87	3.49
A01227-7010	Green	3.87	3.49
A01227-5020	Lt Blue	3.87	3.49
A01227-4410	Orange	3.87	3.49
A01227-3540	Pink	3.87	3.49
A01227-3010	Red	3.87	3.49
A01227-9430	Silver	3.87	3.49
A01227-6010	Violet	3.87	3.49
A01227-1010	White	3.87	3.49
A01227-4010	Yellow	3.87	3.49

Glow in the Dark

NUMBER	COLOR	EACH	6/EA
A01227-1002	Blue	\$4.29	\$3.86
A01227-1001	Green	4.29	3.86
A01227-1003	Orange	4.29	3.86
A01227-1004	Yellow	4.29	3.86

Fluorescent Set of 6 — Fluorescent Blue, Fluorescent Green, Fluorescent Light Blue, Fluorescent Orange, Fluorescent Pink, and Fluorescent Yellow.

NUMBER	EACH	6/EA
A01227-0049	\$23.35	\$20.99

Just Glitter Set of 6 — No pigment or color, just lots of glitter! Use on fabric or paper. Includes Glitter Blue, Glitter Gold, Glitter Green, Glitter Red, Glitter Silver, and Glitter Violet.

NUMBER	EACH	6/EA
A01227-0039	\$25.23	\$22.70

Metallic Set of 6 — Bronze, Brown, Copper, Gold, Silver, and White.

NUMBER	EACH	6/EA
A01227-0029	\$23.35	\$20.99

Pearl Set of 6 — Pearl Black, Pearl Blue, Pearl Green, Pearl Pink, Pearl Violet, and Pearl White.

NUMBER	EACH	6/EA
A01227-0059	\$23.35	\$20.99

Primary Set of 6 — Black, Blue, Green, Red, Violet, and White.

NUMBER	EACH	6/EA
A01227-0009	\$23.35	\$20.99

Secondary Set of 6 — Green, Light Blue, Orange, Pink, Violet, and Yellow.

NUMBER	EACH	6/EA
A01227-0019	\$23.35	\$20.99

For more colors, visit DickBlick.com.



Design Works™ Aida Cloth

This 14-count cross stitch fabric is the perfect base for your next stitching, needlework, or embroidery project. The white fabric is 100% cotton and easy to work with. 60" x 1 yd piece.

NUMBER	SIZE	EACH	6/EA
A63988-1014	60" x 1 yd	\$22.25	\$19.99

NUMBER	DESCRIPTION	SIZE	EACH	6/EA
A63988-1018	Gold Quality	15" x 18"	\$6.08	\$5.47
A63988-1060	Gold Quality	36" x 60"	36.85	33.17



Colorful Plastic Canvas

Plastic needlepoint canvas measures 10-1/2" x 13-1/2". Seven holes per inch.

NUMBER	COLOR	EACH	12/EA	72/EA
A63103-2054	Black	\$1.20	\$1.07	\$.99
A63103-7034	Christmas Green	1.20	1.07	.99
A63103-2984	Christmas Red	1.20	1.07	.99
A63103-1844	Clear	1.20	1.07	.99
A63103-5034	Dark Blue	1.20	1.07	.99
A63103-5024	Light Blue	1.20	1.07	.99
A63103-1044	White	1.20	1.07	.99
A63103-6004	Purple	1.20	1.07	.99
A63103-6044	Lavender	1.20	1.07	.99
A63103-4004	Yellow	1.20	1.07	.99
A63103-3064	Pink	1.20	1.07	.99

BLICK SHIPS QUICK — our reputation for industry-leading shipping times means you'll have it fast!



A-B Design Works™ Muslin

A studio staple for many art, craft, and sewing projects. This high-quality natural muslin fabric is made of tightly woven 100% cotton.

A Unbleached Muslin

NUMBER	SIZE	EACH	6/EA
A63987-1001	45"W x 1 yd	\$7.70	\$6.93
A63987-1005	45"W x 5 yd	27.55	24.79
A01286-1050	47"W x 50 yd	180.78	162.70

B Bleached Muslin

NUMBER	SIZE	EACH	6/EA
A01286-1001	45" x 1 yd	\$8.81	\$7.93
A01286-1005	45" x 5 yd	33.06	29.75
AF01286-1150	45" x 50 yd	215.93	194.33



Brightly Colored and Natural Burlap by the Yard

Here's guaranteed quality and economy, too! Brightly colored, inexpensive material that's easy to manage and drapes nicely for displays and décor. Odor-free. 10 oz weight. 46" wide. Sold by the yard.

NUMBER	COLOR	EACH	15/EA	30/EA
A63202-3236	Barn Red	\$5.20	\$4.65	\$4.44
A63202-2036	Black	5.40	4.83	4.61
A63202-8036	Brown	5.40	4.83	4.61
A63202-2136	Ecliptic Blue	5.20	4.65	4.44
A63202-7236	Hunter Green	5.40	4.83	4.61
A63202-8436	Oyster	5.44	4.87	4.65
A63202-1036	White	5.46	4.89	4.67
A63202-4036	Yellow	5.56	4.97	4.75

Natural Burlap — 10 oz weight. 46" wide. Sold by the yard.

NUMBER	EACH	15/EA	30/EA
A63202-1436	\$4.95	\$4.43	\$4.23



Mountain Mist Fiberloft Polyester Stuffing

Easy-to-use, premium-quality 100% fiberfill is ideal for toys, soft crafts, decorations, pillows, and more. It has a smooth consistency and easily fits into small spaces. Washable, hypoallergenic, and highly resilient. 16 oz bag.

NUMBER	EACH	12/EA
A23949-1006	\$6.65	\$5.98



Zippers

These nylon zippers are 7"L x 1"W.

NUMBER	DESCRIPTION	EACH	6/EA
A63978-1007	Black Invisible	\$1.63	\$1.46
A63978-1107	Olive Exposed Metal	5.50	4.95
A63978-1207	Red Regular	3.35	2.99
A63978-1023	White Regular	2.22	1.98



Anchor® Embroidery Thread

This superior 6-ply thread is perfect for cross stitch and freestyle embroidery projects. The 100% Egyptian cotton is double mercerized, has a unique softness, and has intense light reflection. Strands can be divided into six single plies. Skeins are 8-3/4 yds (8 m) long. For more colors, visit our DickBlick.com.

NUMBER	COLOR	EACH	12/EA
A73518-2020	Black, 0403	\$8.98	\$8.09
A73518-5010	Blue, 0128	8.98	8.09
A73518-5013	Blue, 0132	8.98	8.09
A73518-7012	Green, 0236	8.98	8.09
A73518-2500	Grey, 0398	8.98	8.09
A73518-3062	Pink, 0027	8.98	8.09
A73518-6001	Purple, 0100	8.98	8.09
A73518-3010	Red, 0047	8.98	8.09
A73518-1020	White, 0001	8.98	8.09
A73518-4010	Yellow, 0291	8.98	8.09



Creativity Street® Embroidery Floss Set

Includes 24 skeins, two each of 12 bright colors. Each skein is 8 yds long. The non-toxic thread is great for a multitude of projects, including friendship bracelets, stringing beads, needlecraft, and more.

NUMBER	EACH	6/EA
A63100-1009	\$8.90	\$7.99



new!

NEW! Bamboo Embroidery Hoops

Made of eco-friendly bamboo, these versatile hoops are ideal for embroidery, needlecraft, and quilting. They can also be used as wall decorations or ornaments.

NUMBER	SIZE	EACH	12/EA
A73584-1003	3"	\$1.65	\$1.48
A73584-1005	5"	1.87	1.68
A73584-1006	6"	1.98	1.78
A73584-1007	7"	2.30	2.07
A73584-1008	8"	2.53	2.27
A73584-1010	10"	2.75	2.47



A-D Dual Duty XP® All Purpose Thread Sets

Ideal for most hand and machine sewing, this medium-weight, 100% polyester thread can be used on all fibers, knits, and wovens.

NUMBER	DESCRIPTION	EACH	3/EA
A63116-1140	A 4 pk of White	\$8.19	\$7.37
A63116-2040	B 4 pk of Black and Greys	8.19	7.37
A63116-5040	C 4 pk of Blues	8.19	7.37
A63116-1290	D 9 pk of Multi Colors	9.13	8.22

NEW! DMC Floss Bobbins

Keep your embroidery flosses organized with DMC Floss Bobbins. Cardboard Floss Bobbins include space for you to write in the floss color number. Plastic Floss Bobbins are available with or without an easy-open 2½" metal storage ring.

NUMBER	DESCRIPTION	EACH	6/EA
A62473-1001	Cardboard Pkg of 56	\$1.86	\$1.67
A62473-1002	Plastic Pkg of 28	1.86	1.67
A62473-1003	Plastic Pkg of 28 w/ Metal Ring	1.97	1.77



new!

NEW! Craft Medley Crafty Supply Box

This heavy-duty craft supply box features multiple compartments for holding beads, embroidery floss, buttons, and other small embellishments. A secure latch prevents contents from spilling during transport.

NUMBER	SIZE	EACH	6/EA
A80920-1001	6 1/2" x 9 1/8"	\$5.93	\$5.33
A80920-1002	11" x 17"	6.92	6.23



Dual Duty XP® Thread Set

A medium-weight thread sized for most hand and machine sewing. Strong and smooth for consistent tension and excellent stitch formation, it can be used on all fibers, knits, and wovens. A new trap spool design holds the thread neatly and securely. Set contains 50 spools in a variety of colors, including multicolored. Each spool is 125 yds.

NUMBER	EACH	3/EA
A63116-1050	\$76.28	\$68.65



E Gutermann Sew-All Polyester Thread

Truly all-purpose, this strong and durable 100% polyester thread works with any fabric or seam and is great for both hand and machine sewing. It boasts excellent tear- and abrasion-resistance, and there's no fiber lint or seam crimping with sewing. Guaranteed knot-free. Spools measure 547 yds.

NUMBER	COLOR	EACH	12/EA
A62400-2027	Black	\$6.12	\$5.50
A62400-1007	Clove	6.12	5.50
A62400-1257	Eggshell	6.12	5.50
A62400-2187	Midnight	6.12	5.50
A62400-2327	Mist Grey	6.12	5.50
A62400-3087	Scarlet	6.12	5.50
A62400-2607	Slate	6.12	5.50
A62400-1577	White	6.12	5.50

F Gutermann Cotton Thread

This 50 weight mercerized cotton thread is ideal for all your artistic creations. Strong with a silky finish, it's suitable for both hand and machine sewing. Spools measure 876 yds long.

NUMBER	COLOR	EACH	6/EA
A66910-8036	Bark Brown	\$8.49	\$7.63
A66910-2016	Black	8.49	7.63
A66910-8146	Burlap Beige	8.49	7.63
A66910-1106	Cream	8.49	7.63
A66910-9006	Gold	8.49	7.63
A66910-2546	Grey	8.49	7.63
A66910-2806	Iron Grey	8.49	7.63
A66910-3296	Mauve	8.49	7.63
A66910-5046	Navy	8.49	7.63
A66910-1556	Oak Tan	8.49	7.63
A66910-3026	Red	8.49	7.63
A66910-5056	Royal Blue	8.49	7.63
A66910-3516	Salmon	8.49	7.63
A66910-8306	Taupe	8.49	7.63
A66910-1516	Vanilla Cream	8.49	7.63
A66910-1026	White	8.49	7.63



Lion Brand Punch Needle

"Paint" with thread using Lion Brand Punch Needle! Set up your working yarn through the needle and easily create pictures on canvas. With a punch needle, one side of the fabric will have a looped effect, like rug hooking, and the other side will have stitches that resemble embroidery.

NUMBER	EACH	5/EA
A62453-5010	\$8.79	\$7.90

John Bead Multi-Purpose Needles

Stitch and sew a wide variety of projects with John Bead Multi-Purpose Needles. Each set contains a threader and 19 assorted needles, including beading and glover needles, plus carpet, packaging, mattress, canvas, and lampshade needles.

NUMBER	EACH	6/EA
A73556-1001	\$5.49	\$4.93



Dritz™ Embroidery Needles

Accomplish a wide variety of projects with Dritz Embroidery Needles. The all-purpose, medium length needles have long eyes for easier threading. They're ideal for general-purpose sewing, embroidery, and crewel. All needles are size 3/9.

NUMBER	EACH	6/EA
A62430-1001	\$2.19	\$1.97



Dritz® Disappearing Ink Marking Pen

Transfer pattern markings and needlecraft and quilting designs with purple, air-soluble and watersoluble ink. Remove the ink with a damp cloth, so you can see it for as long as you need to.

NUMBER	EACH	6/EA
A62429-6001	\$6.60	\$5.94



Clover® Tailors Chalk

Easy to hold, this triangular chalk is perfect for marking sewing and quilting projects. Marks can be easily brushed off when the project is finished, but cannot be removed once ironed or dry-cleaned. Pressing the chalk too hard makes the marking difficult to remove.

NUMBER	COLOR	EACH	6/EA
A62433-5010	Blue	\$2.41	\$2.16
A62433-3010	Red	2.41	2.16
A62433-1020	White	2.41	2.16
A62433-4010	Yellow	2.41	2.16



Needles

G John Bead Gold Eye Beading Needles. Package of 7.

NUMBER	SIZE	EACH	12/EA	24/EA
A73546-1002	10	\$2.05	\$1.84	\$1.75
A73546-1003	11	2.05	1.84	1.75

H #18 Blunt Tapestry Needle — For medium yarns and raffia. Package of 12.

NUMBER	EACH	12/EA	24/EA
A66903-1009	\$2.17	\$1.95	\$1.85

I #13 Blunt Tapestry — Large eye for thick yarns. Package of 12.

NUMBER	EACH	12/EA	24/EA
A65104-1009	\$5.55	\$4.99	\$4.73

J Needle Crafters Plastic Finishing Needles.

NUMBER	EACH	12/EA	24/EA
A73579-1001	\$1.75	\$1.57	\$1.49

K 6" Plastic Weaving Needle — For use with looms or open-weave fabric. Flexible and safe. Large eye makes it easy to weave wall hangings, placemats, scarves, and more. Package of 12.

NUMBER	EACH	12/EA	24/EA
A65109-1009	\$3.40	\$3.06	\$2.91



Clover® Natural Felting Wool

100% natural wool roving is ideal for felting, appliqués, thrumming, spinning, costume wigs, pom-poms, locker hooking, and other handicrafts.

NUMBER	COLOR	EACH	6/EA
A63239-2610	Ash	\$4.63	\$4.15
A63239-2020	Black	4.63	4.15
A63239-5010	Blue	4.63	4.15
A63239-8000	Brown	4.63	4.15
A63239-9010	Gold	4.63	4.15
A63239-7520	Moss Green	4.63	4.15
A63239-1580	Off White	4.63	4.15
A63239-3060	Pink	4.63	4.15
A63239-3010	Red	4.63	4.15

N Felting Needles

A four-pack of hand tools used for needle felting. Includes a 38 gauge (medium) star point needle and three triangle point needles (40 gauge extra fine, 38 gauge medium coarse, and 36 gauge coarse).

NUMBER	EACH	6/EA
A63122-1004	\$8.47	\$7.62

L Seam Ripper

This sturdy plastic and metal seam ripper makes stitch removal a snap. It measures 5" long.

NUMBER	EACH	6/EA
A63182-1001	\$6.05	\$5.44

M Sewing Awl

Punch holes through thick fabrics like canvas, leather, and suede with this fine-quality awl. With a strong metal tip and comfortable wooden handle, it measures 4-1/4" long.

NUMBER	EACH	6/EA
A63179-1001	\$6.57	\$5.91



O Clover® Felting Tools

Use these tools with natural felt, wool yarn, or felt sheets with a wool content of 50% or higher. Choose the pen for small or delicate projects, or use the felting tool with a felting mat for making appliqués. Refills contain five needles; use Fine for most fabrics and Heavy for attaching appliqués to knits.

NUMBER	DESCRIPTION	EACH	6/EA
A63237-1020	Felting Needle	\$15.40	\$13.87
A63237-1010	Pen Style	13.18	11.87
A63237-1030	Needle Refill, Fine	7.23	6.50
A63237-1040	Needle Refill, Heavy	7.23	6.50

P Clover® Felting Mats

Punching on this brush-like felting mat assures that appliqué fibers mesh well with the base fabric. The mat's bristles are ideal for smooth punching and minimal resistance.

NUMBER	DESCRIPTION	SIZE	EACH	6/EA
A63236-1010	Small	2-3/4" x 3-1/2"	\$11.27	\$10.14
A63236-1030	Large	3-1/4" x 5"	18.35	16.52



Fiskars® Rotary Cutter

A classic, easy-to-grip tool perfect for cutting cloth, felt, paper, and vinyl. Its two-position safety lock with spring-action mechanism automatically closes after every cut. No small washers, so blade changing is easy. The gray, soft plastic handle is contoured for comfort and control. Use right- or left-handed.

NUMBER	DESCRIPTION	EACH	6/EA
A57427-1045	Cutter	\$21.25	\$19.12
A57427-1145	Replacement Blade	8.35	7.50



Fiskars® Easy Action™ Scissors

Stainless steel blades with adjustable tension and a unique spring-action design that greatly reduces hand strain and fatigue. The Softgrip handle adds comfort. Cut fabric, felt, paper, and more. Can be used left- or right-handed.

NUMBER	EACH	12/EA
A57017-0000	\$21.65	\$19.49



Gingher Scissors and Shears

Precision-ground knife edges cut through multiple layers of fabric with ease and feature a durable, double-plated chrome over nickel finish. Shears feature a bent handle offers a comfortable working angle, and allows the shears to lie flush with the fabric and cutting surface. A safety latch locks the blades together when the shears are not in use. Scissors come in a leather sheath.

Sewing Scissors — Ideal for quilting, sewing, and crafts, these scissors cut multiple layers of fabric. They feature a durable, double-plated chrome over nickel finish and come in a leather sheath.

NUMBER	SIZE	EACH	12/EA
A57093-1005	5"	\$31.57	\$28.42

Dressmaker's Shears — A durable spring action opens shears after each cut so you're always ready for the next one. The precision-ground knife edges cut multiple layers of fabric with ease, making them perfect for cutting patterns and trimming seams. Durable, double-plated chrome over nickel finish.

NUMBER	SIZE	EACH	12/EA
A57093-2008	8"	\$38.65	\$34.78



Fiskars® Premier Pinking Shears

Made of high-grade stainless steel, the shear's sawtooth blades leave a zigzag pattern when you cut, helping to prevent fraying. The blades cut all the way to the tip — essential when cutting fabric. Ergonomic handle provides unmatched cutting control. Bent design keeps materials flat for precise cuts every time.

NUMBER	EACH	12/EA
A57621-1008	\$28.03	\$25.23



X-Acto® Multi Material Scissors

Able to shear much more than just paper, these scissors are tough enough to handle denim, felt, cork, leather, plastic sheeting, and aluminum wire (up to 12 gauge). Accommodates both right- and left-handed users.

NUMBER	EACH	12/EA
A57535-2510	\$11.99	\$10.80



Fiskars® Premier Thread Snips

Cut thread, embroidery floss, and yarn with ease! The spring-action squeeze handle with finger loop makes cutting easy and comfortable. Precision-ground stainless steel blades have tiny, pointed tips that let you make quick, precise snips into small spaces and awkward angles with exceptional control.

NUMBER	EACH	18/EA
A57623-1001	\$8.47	\$7.62



Allary Embroidery Scissors

Perfect for needlework, yarn, embroidery, and sewing projects. The ultra-fine, 3-1/2" long scissors feature gold-plated handles and precision-pointed, stainless steel blades.

NUMBER	DESCRIPTION	EACH	6/EA
A62439-1002	Scroll	\$4.39	\$3.95
A62439-1001	Stork	4.39	3.95



Westcott® Wood Yardstick

Economical wood yardstick includes a convenient hole for hanging. 36" long and calibrated in 1/8" increments. 1-1/8" wide.

NUMBER	EACH	12/EA	24/EA
A55706-1036	\$4.55	\$4.08	\$3.89



Dritz® Flip-It Tape Measure

This extra-wide measuring tape has large, clear markings. One side measures 144" and the other side continues up to 288", so you can "flip it" and keep measuring. Made of non-stretch, reinforced fiberglass.

NUMBER	EACH	6/EA
A73509-1144	\$3.83	\$3.45

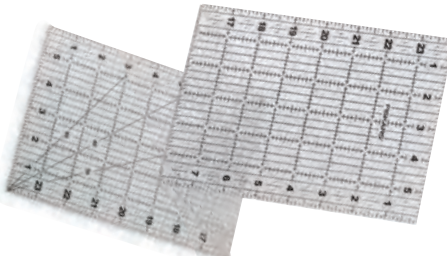

Fiskars® Folding Ruler

Make long cuts without the bulk of a regular ruler. This portable measuring tool folds to a third of its size. Clear, durable hinges allow it to lie perfectly flat for smooth cuts without catching or snagging. The acrylic ruler's two-tone grid makes it easy to measure on light, dark, and patterned fabrics. Angle lines in 30°, 40°, and 60° increments simplify angle cutting. Opens to 6" x 24" and folds to 6" x 8".

NUMBER	EACH	6/EA
A63986-1024	\$28.20	\$25.38



Armada® Embroidery Scissors

Essential for any sewing kit. Also great for very detailed, precise paper cutting. 4" long with a 1-1/4" cut.

NUMBER	EACH	12/EA
A57042-0004	\$4.47	\$4.03



Lily® Sugar 'N Cream Yarn

A favorite with knitters and crafters for years, this is the original 4-ply 100% cotton Sugar 'n Cream worsted yarn. Naturally soft and absorbent, it's ideal for knitted, crocheted, and craft projects such as vests, sweaters, caps, and lightweight throws. Machine wash and dry. Solid colors come in a 2.5 oz skein and multicolors come in a 2 oz skein.

NUMBER	COLOR	EACH	12/EA
A65236-1180	American Stripes	\$3.27	\$2.94
A65236-2050	Black	3.27	2.94
A65236-1270	Black Current	3.27	2.94
A65236-4870	Blue Jeans	3.27	2.94
A65236-1280	Blueberry	3.27	2.94
A65236-5070	Bright Navy	3.27	2.94
A65236-1190	Capri Ombre	3.27	2.94
A65236-7730	Country Green	3.27	2.94
A65236-7410	Country Sage	3.27	2.94
A65236-1780	Country Stripes	3.27	2.94
A65236-1170	Daisy	3.27	2.94
A65236-7330	Dark Pine	3.27	2.94
A65236-1290	Dazzle Blue	3.27	2.94
A65236-1450	Ecu	3.27	2.94
A65236-6090	Grape	3.27	2.94
A65236-7550	Hot Green	3.27	2.94
A65236-4550	Hot Orange	3.27	2.94
A65236-3290	Hot Pink	3.27	2.94
A65236-5200	Indigo	3.27	2.94
A65236-1770	Jewels Ombre	3.27	2.94
A65236-7230	Key Lime Pie Ombre	3.27	2.94
A65236-5010	Light Blue	3.27	2.94
A65236-7240	Lime Stripe	3.27	2.94
A65236-1230	Mango Madness Ombre	3.27	2.94
A65236-7030	Mod Green	3.27	2.94
A65236-1900	Mod Ombre	3.27	2.94
A65236-1250	Overcast	3.27	2.94
A65236-1980	Painted Ombre	3.27	2.94
A65236-2980	Red	3.27	2.94
A65236-1210	Red White Blue Ombre	3.27	2.94
A65236-3160	Rose Pink	3.27	2.94
A65236-7400	Sage Green	3.27	2.94
A65236-1260	Seabreeze	3.27	2.94
A65236-1460	Soft Ecu	3.27	2.94
A65236-6550	Soft Violet	3.27	2.94
A65236-1160	Spring Swirl	3.27	2.94
A65236-1310	Stonewash	3.27	2.94
A65236-4390	Sunshine	3.27	2.94
A65236-1990	Swim Pool Ombre	3.27	2.94
A65236-4630	Tangerine	3.27	2.94
A65236-3170	Tea Rose	3.27	2.94
A65236-6510	Violet Stripe	3.27	2.94
A65236-8810	Warm Brown	3.27	2.94
A65236-1040	White	3.27	2.94
A65236-3550	Wine	3.27	2.94
A65236-4020	Yellow	3.27	2.94

For more yarn lines, visit DickBlick.com.



Red Heart® Super Saver® Yarn

A great go-to yarn for home décor, craft, and clothing projects. The solid-color yarn has no dye lot, so you'll get consistent color from skein to skein. Durable, worsted weight, 4-ply yarn. 100% acrylic. Machine wash and dry. Solids come in 7 oz skeins. Multicolors and heathers come in 5 oz skeins.

NUMBER	COLOR	SIZE	EACH	12/EA
A65267-3711	Amethyst	7 oz	\$5.72	\$5.13
A65267-1201	Antique	5 oz	5.72	5.13
A65267-1010	Aran	7 oz	5.72	5.13
A65267-2020	Black	7 oz	5.72	5.13
A65267-4290	Bright Yellow	7 oz	5.72	5.13
A65267-1170	Buff	7 oz	5.72	5.13
A65267-2150	Charcoal	7 oz	5.72	5.13
A65267-3450	Cherry Red	7 oz	5.72	5.13
A65267-4910	Flamingo	7 oz	5.72	5.13
A65267-2420	Grey Heather	5 oz	5.72	5.13
A65267-7010	Light Grey	7 oz	5.72	5.13
A65267-7910	Macaw	5 oz	5.72	5.13
A65267-6000	Medium Purple	7 oz	5.72	5.13
A65267-1100	Neon Stripes	5 oz	5.72	5.13
A65267-7020	Paddy Green	7 oz	5.72	5.13
A65267-1200	Primary Stripes	5 oz	5.72	5.13
A65267-5050	Royal	7 oz	5.72	5.13
A65267-5040	Soft Navy	7 oz	5.72	5.13
A65267-1190	Soft White	7 oz	5.72	5.13
A65267-5110	Turqua	7 oz	5.72	5.13
A65267-1040	White	7 oz	5.72	5.13



NEW! Lion Brand Re-Up® Yarn

Super soft and eco-friendly, Lion Brand Re-Up Yarn is made with recycled cotton. Knit dishcloths, baby clothes and accessories, plus a wide variety of craft projects. The 85% cotton/15% polyester yarn has a medium 4 weight. Each 2.5 oz (70 g) solid-color skein has 117 yds (107 m) of yarn, and each 2.1 oz (60 g) multicolor skein has 103 yds (94 m) of yarn. Use it with 5.5 mm crochet hooks and 4.5 mm knitting needles. Machine wash and dry.

NUMBER	COLOR	EACH	6/EA
A62821-2610	Ash	\$2.74	\$2.45
A62821-5910	Aqua	3.29	2.95
A62821-1010	Azul	2.74	2.45
A62821-3720	Bubble Gum	2.74	2.45
A62821-1030	Confetti	2.74	2.45
A62821-1040	Cotton Candy	2.74	2.45
A62821-7230	Lime	3.29	2.95
A62821-3360	Raspberry	3.29	2.95
A62821-5160	Sky	3.29	2.95
A62821-4920	Sunflower	3.29	2.95
A62821-4510	Orange	3.29	2.95



Caron® One Pound Acrylic Yarn

Non-allergenic and moth-proof with pull skein convenience. Machine wash and dry. The greatest feature — consistent color! There's no dye lot. Two free patterns on the wrapper. Worsted weight. 4-ply. 100% acrylic. 1 lb skeins.

NUMBER	COLOR	EACH	6/EA
A65230-5160	Aqua	\$10.79	\$9.71
A65230-5120	Azure	10.79	9.71
A65230-2000	Black	10.79	9.71
A65230-5910	Cape Cod Blue	10.79	9.71
A65230-3120	Claret	10.79	9.71
A65230-3180	Country Rose	10.79	9.71
A65230-1100	Cream	10.79	9.71
A65230-2530	Dark Grey	10.79	9.71
A65230-3320	Dark Pink	10.79	9.71
A65230-6610	Deep Violet	10.79	9.71
A65230-5920	Denim	10.79	9.71
A65230-6000	Espresso	10.79	9.71
A65230-7240	Green	10.79	9.71
A65230-7360	Kelly Green	10.79	9.71
A65230-1020	Lace	10.79	9.71
A65230-1610	Lavender Blue	10.79	9.71
A65230-6030	Lilac	10.79	9.71
A65230-2520	Medium Grey	10.79	9.71
A65230-5800	Midnight Blue	10.79	9.71
A65230-5320	Ocean Blue	10.79	9.71
A65230-1580	Off White	10.79	9.71
A65230-7020	Pale Green	10.79	9.71
A65230-3350	Peach	10.79	9.71
A65230-6010	Purple	10.79	9.71
A65230-3170	Rose	10.79	9.71
A65230-1600	Royalty	10.79	9.71
A65230-3080	Scarlet	10.79	9.71
A65230-5070	Sky Blue	10.79	9.71
A65230-2510	Soft Grey	10.79	9.71
A65230-3510	Soft Pink	10.79	9.71
A65230-7380	Soft Sage	10.79	9.71
A65230-4920	Sunflower	10.79	9.71
A65230-8300	Taupe	10.79	9.71
A65230-1000	White	10.79	9.71



Lion Brand® Wool-Ease® Yarn

The softness, warmth, and feel of wool meets the easy care of acrylic. Machine wash and dry. Worsted weight. 4-ply. Solids, Heathers, Denim Twist, and Wheat come in 3 oz balls. White Glitter, White Frost, and Prints come in 2.5 oz balls. For fiber content, visit DickBlick.com.

NUMBER	COLOR	EACH	12/EA
A65247-8020	Antler	\$5.89	\$5.29
A65247-1100	Arrowwood	5.89	5.29
A65247-2050	Black	5.89	5.29
A65247-5900	Blue Mist	5.89	5.29
A65247-3300	Blush Heather	5.89	5.29
A65247-3310	Cranberry	5.89	5.29
A65247-3330	Dark Rose Heather	5.89	5.29
A65247-5910	Denim	5.89	5.29
A65247-8440	Fisherman	5.89	5.29
A65247-7270	Forest Heather	5.89	5.29
A65247-5070	Navy	5.89	5.29
A65247-2380	Oxford Grey	5.89	5.29
A65247-3320	Rose Heather	5.89	5.29
A65247-1090	Stillwater	5.89	5.29
A65247-7100	Succulent	5.89	5.29
A65247-4960	Wheat	5.89	5.29
A65247-1510	White Glitter	5.89	5.29



Lion Brand Bonbons Yarn

Each collection of Lion Brand Bonbons Yarn contains eight mini balls of acrylic, cotton, or polyester yarns in eight different shades. They're perfect for any project requiring multiple colors, such as amigurumi, kids' crafts, friendship bracelets, embroidery, knitting, crocheting, and embellishments. Collections contain a total of 28 yards with a .35 oz weight.

NUMBER	COLOR	EACH	12/EA
A62847-1003	Beach	\$8.99	\$8.09
A62847-1001	Brights	8.99	8.09
A62847-1006	Celebrate	8.99	8.09
A62847-1007	Crayons	8.99	8.09
A62847-1004	Nature	8.99	8.09
A62847-1005	Party	8.99	8.09
A62847-1002	Pastels	8.99	8.09



Maysville Cotton Warp

Sturdy classic cotton yarn is versatile and economical, time-tested and proven. Ideal for the beginning weaver or for rag rugs, runners, towels, placemats, and more. Made from 100% American grown and dyed cotton. 4-ply, strong, durable warp on 1/2 lb, 800 yd tubes.

NUMBER	COLOR	EACH	12/EA
A62800-2050	Black	\$10.75	\$9.68
A62800-8150	Bronze Gold	10.75	9.68
A62800-8000	Brown	10.75	9.68
A62800-3220	Cardinal Kentucky Red	10.75	9.68
A62800-5010	Colonial Light Blue	10.75	9.68
A62800-1500	Linen	10.75	9.68
A62800-7130	Loden Green	10.75	9.68
A62800-7320	Myrtle Green	10.75	9.68
A62800-1350	Natural	8.55	7.69
A62800-5070	Navy Blue	10.75	9.68
A62800-5630	Purple	10.75	9.68
A62800-1040	White	10.75	9.68



All Color Assortment



Earthtone Assortment

Classroom Yarn Assortments

Made with a mixture of synthetic and wool fibers, these yarns are of great quality. They come in handy pull skeins, ready to be used in all of your weaving, craft, and collage projects. 5 lb assortments. Colors may vary.

NUMBER	DESCRIPTION	EACH	3/EA
A65208-1005	All Color Assortment	\$36.45	\$32.80
A65208-1009	Earthtone Assortment	36.45	32.80



A-M Wistyrria Editions Wool Roving Fleece

This 100% wool fleece is wonderful for any project that requires high-quality wool. Sourced from New Zealand Corriedale sheep, it's ideal for felting, wet felting, needle felting, locker hooking, thrumming, spinning, costume wigs, and more. Each 2 oz bag contains eight 12" long pieces of fleece in assorted colors.

NUMBER	COLOR	EACH	6/EA
A63235-1012	A Hydrangeas	\$19.94	\$17.98
A63235-1003	B Jungle	19.94	17.98
A63235-1014	C Lilacs	19.94	17.98
A63235-1010	D Neutrals	19.94	17.98
A63235-1020	E Primaries	19.94	17.98
A63235-1018	F Pumpkin	19.94	17.98
A63235-1011	G Rustic	19.94	17.98
A63235-1023	H The Sea	19.94	17.98
A63235-1015	I Timberland	19.94	17.98
A63235-1017	J Tranquility	19.94	17.98
A63235-1016	K Vintage	19.94	17.98
A63235-1050	L Woodsy	19.94	17.98
A63235-1013	M Zinnias	19.94	17.98

For more Wistyrria Editions Wool Roving Fleece, visit DickBlick.com.



Trait-tex Cotton Warp

100% cotton. Natural color. 8 oz cones.

NUMBER	DESCRIPTION	EACH	12/EA
A65211-1475	8/4, 800 yds, Heavy	\$14.45	\$12.99
A65211-1375	10/2, 2100 yds, Light	14.45	12.99



Trait-tex School Roving Yarn

Ideal for general classroom use. 100% acrylic yarn. Individually bagged in a convenient poly dispenser pack. 3-ply air-fluffed yarn comes in 8 oz skeins. Approximately 450 ft.

NUMBER	COLOR	EACH	12/EA
A65223-2000	Black	\$17.68	\$15.90
A65223-5030	Dark Blue	17.68	15.90
A65223-8030	Dark Brown	17.68	15.90
A65223-7140	Dark Green	17.68	15.90
A65223-3290	Hot Pink	17.68	15.90
A65223-4500	Orange	17.68	15.90
A65223-6000	Purple	17.68	15.90
A65223-3000	Red	17.68	15.90
A65223-1000	White	17.68	15.90
A65223-4000	Yellow	17.68	15.90

Trait-tex Heavy Polyester Rug Yarn

A great classroom yarn in a convenient poly dispenser pack! 100% polyester, non-allergenic fiber. 1.37 oz pull skein, 60 yds, 3-ply.

NUMBER	COLOR	EACH	12/EA
A65224-2000	Black	\$6.10	\$5.49
A65224-8000	Brown	6.10	5.49
A65224-7640	Christmas Green	6.10	5.49
A65224-4620	Pumpkin	6.10	5.49
A65224-3000	Red	6.10	5.49
A65224-5280	True Blue	6.10	5.49
A65224-1000	White	6.10	5.49
A65224-4000	Yellow	6.10	5.49



Trait-tex Standard Weight Yarn

Designed for large group instruction in stitchery, appliqué, and weaving projects. 2-ply 100% acrylic. Nine cones, each 8 oz, 630 yds. Total of 5,670 yds.

NUMBER	DESCRIPTION	EACH	5/EA
A65215-0000	Bright Colors in Dispenser Box	\$148.68	\$133.81

Bright Colors in Dispenser Box — White, Black, Blue, Violet, Red, Orange, Yellow, Green, and Dark Brown.

NUMBER	DESCRIPTION	EACH	5/EA
A65215-0100	Intermediate Colors in Dispenser Box	\$148.68	\$133.81

Intermediate Colors in Dispenser Box — Gray, Blue-Violet, Yellow-Orange, Dark Brown, Dark Green, Black, Turquoise, Pink, and Light Brown.



Trait-tex Jumbo Roving Neon Colors

100% acrylic 4-ply yarn in hot neon colors for kids of all ages. Dispenser box contains nine cones: Neon Red, Neon Yellow, Neon Orange, Neon Chartreuse, Neon Green, Neon Blue, Neon Violet, Neon Pink, and Neon Strawberry. Each 21 yds, total 189 yds.

NUMBER	DESCRIPTION	EACH	6/EA
A65222-1004	Neon Colors in Dispenser Box	\$59.10	\$53.20



Trait-tex Econ-O-Yarn Assortment

May include acrylic, polyester, wool, and wool blends, in a full range of sizes, colors, and textures on pre-wound cones, pull skeins, and tubes. Heathers, solids, brights, and earth tones, in nub and flake effects, novelty twists, and various textures. Ideal for weaving, macramé, and crafts. Not packed in a dispenser box.

NUMBER	DESCRIPTION	EACH	3/EA
A65216-1009	Econ-O-Yarn Assortment	\$179.29	\$161.35

TRAIT-TEX



Trait-tex Jumbo Roving Yarn

Ideal for young students of preschool and elementary age, and for large, heavy multimedia projects. An excellent yarn for simple weaving, macramé, three-dimensional projects, yarn painting. 4-ply 100% acrylic. 8 oz cones, 85 yds each.

Bright Colors in Dispenser Box — Nine cones, total 765 yds: White, Black, Blue, Violet, Red, Orange, Yellow, Green, and Dark Brown.

NUMBER	DESCRIPTION	EACH	5/EA
A65214-1004	Bright Colors in Dispenser Box	\$148.68	\$133.81

Intermediate Colors in Dispenser Box — Nine cones, total 765 yds: Gray, Blue-Violet, Yellow-Orange, Dark Brown, Dark Green, Black, Turquoise, Pink, and Light Brown.

NUMBER	DESCRIPTION	EACH	5/EA
A65214-1104	Intermediate Colors in Dispenser Box	\$148.68	\$133.81

Open Stock Refill Cones — 4-ply.

NUMBER	COLOR	EACH	12/EA
A65214-2000	Black	\$18.26	\$16.43
A65214-5000	Blue	18.26	16.43
A65214-7000	Green	18.26	16.43
A65214-4500	Orange	18.26	16.43
A65214-3000	Red	18.26	16.43
A65214-1000	White	18.26	16.43
A65214-4000	Yellow	18.26	16.43



Trait-tex Double Weight Rug Yarn

Ideal for all techniques of rug making, weaving, knitting, crocheting, yarn painting, stitchery, and most classroom yarn activities. 4-ply 100% acrylic yarn. 8 oz cones, 315 yds each.

Bright Colors in Dispenser Box — Nine cones, total 2,835 yds: White, Black, Blue, Violet, Red, Orange, Yellow, Green, and Dark Brown.

NUMBER	DESCRIPTION	EACH	5/EA
A65213-1004	Bright Colors in Dispenser Box	\$148.68	\$133.81

Intermediate Colors in Dispenser Box — Nine cones, total 2,835 yds. Gray, Blue-Violet, Yellow-Orange, Dark Green, Black, Turquoise, Pink, Light Brown, and Dark Brown.

NUMBER	DESCRIPTION	EACH	5/EA
A65213-1104	Intermediate Colors in Dispenser Box	\$148.68	\$133.81

Open Stock Refill Cones — 4-ply.

NUMBER	COLOR	EACH	12/EA
A65213-2000	Black	\$18.26	\$16.43
A65213-5000	Blue	18.26	16.43
A65213-7000	Green	18.26	16.43
A65213-4500	Orange	18.26	16.43
A65213-3000	Red	18.26	16.43
A65213-1000	White	18.26	16.43
A65213-4000	Yellow	18.26	16.43

actual thickness of trait-tex yarns



knitting looms

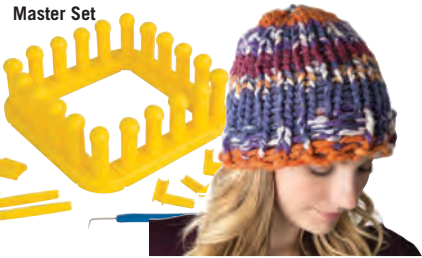

KB Zippy™ Loom
Knit a chunky scarf or hat in as little as 20 minutes. The large pegs produce very quick projects. Knitting with one Zippy section produces a 3" to 4" width. Expand your loom size by adding more pieces. Great for beginners.

Master Set — Build four unique configurations. Includes four Zippy Loom sections, four corners, 10 connectors, a loom hook tool, instructions, and four project patterns.

NUMBER	EACH	6/EA
A65092-1009	\$33.06	\$29.75

Zippy Loom — Build a longer loom to create wider items such as blankets and shawls. Package includes a four-peg Zippy, a connector, a loom hook tool, and instructions.

NUMBER	EACH	12/EA
A65092-1001	\$8.52	\$7.67

Zippy Loom Corners — Connect sections to create a round loom. Package includes four corner pieces and four project patterns.

NUMBER	EACH	12/EA
A65092-1002	\$8.52	\$7.67



Knitting Needles

Made of lightweight aluminum, these 10" knitting needles are great for children just learning to knit. Sold in pairs.

NUMBER	SIZE	EACH	6/EA
A63119-1005	5	\$4.55	\$4.09
A63119-1006	6	4.55	4.09
A63119-1007	7	4.55	4.09
A63119-1008	8	4.78	4.30
A63119-1009	9	4.78	4.30
A63119-1010	10	4.78	4.30
A63119-1105	10.5	5.18	4.67
A63119-1011	11	5.18	4.67



Clover Takumi Bamboo Straight Knitting Needles

Lightweight with an ultra-smooth finish, these single pointed needles feature perfectly straight shafts and a design that's easy on hands.

NUMBER	SIZE	EACH	6/EA
A62404-1009	9	\$5.34	\$4.80
A62404-1010	10	5.34	4.80
A62404-1011	11	8.20	7.38
A62404-1013	13	8.20	7.38
A62404-1015	15	8.20	7.38



Plastic Crochet Hook Set

Includes six plastic needles in various sizes: F-5, G-6, H-8, I-9, J-10, and K-10-1/2.

NUMBER	EACH	6/EA
A65105-1009	\$3.58	\$3.22



Friendly Loom

At home or school, weaving can be an exciting alternative to the usual art and craft activities. Students can make wall hangings, pillow covers, rugs, table runners, bookmarks, and more. This loom is made of finished hardwood and equipped with unbreakable nylon pegs that are used to hold the warp in place. Frame adjusts from 44" to 64" and measures 61" wide with a 48" weaving width. Bench not included. FOB Factory. See page 648 for details.

NUMBER	EACH
AF65013-1048	\$325.00



Cardboard Looms

Economical beginner's looms for teaching textile weaving and design to very young students. Made of practically indestructible chipboard, 1/8" thick, notched on both ends, four notches to the inch. Packages of 12 looms.

NUMBER	SIZE	EACH	12/EA
A65005-0000	3-1/4" x 13"	\$5.83	\$5.26
A65005-1006	6" x 10"	9.45	8.53
A65005-1065	6-1/2" x 13"	9.35	8.42
A65005-1098	9-3/4" x 13"	15.49	13.94
A65005-1005	13" x 13"	21.93	19.73

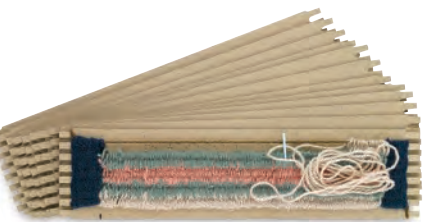

Wide-Notch Cardboard Looms

Notches have larger spaces so thicker yarn can be used. Projects can be completed in a shorter amount of time. Each package includes 12 looms; assorted package includes 20.

NUMBER	SIZE	EACH	12/EA
A65002-1373	3-1/4" x 13"	\$7.99	\$7.21
A65002-1377	4" x 6"	5.24	4.72
A65002-1372	6-1/2" x 13"	14.78	13.30
A65002-1375	9-3/4" x 13"	21.62	19.45
A65002-1376	13" x 13"	29.18	26.26
A65002-1379	Assorted	30.35	27.31



A Schacht® Flat Shuttle

Smoothly sanded hardwood. Approximately 2-1/2" wide.

NUMBER	SIZE	EACH	12/EA
A65008-1095	9"	\$11.98	\$10.79
A65008-1016	16"	12.55	11.30

B Schacht® Belt Shuttle

Small shuttle features a beveled edge for beating in the weft when weaving narrow bands. Good for use with inkle looms. 8" x 1-3/4" x 1/4".

NUMBER	EACH	3/EA
A65018-1030	\$14.74	\$13.27

C Schacht® Boat Shuttle

A well-balanced boat shuttle to hold bobbin yarn for weaving. Hard maple construction with a smooth, oiled finish. Use with Schacht 4" bobbin.

NUMBER	EACH	3/EA
A65018-1070	\$45.31	\$40.79

D Schacht® Heddle Hook

Use for threading reeds and rigid heddle reeds. 8" x 3/4".

NUMBER	EACH	3/EA
A65018-1040	\$13.65	\$12.29

E Schacht® Brass Reed Hook

This S-shaped brass reed hook is designed to fit comfortably in the hand, with a large hook that makes slewing various yarns easy.

NUMBER	EACH	3/EA
A65018-1050	\$9.28	\$8.35

F Schacht® Single End Tapestry Beater

Used to beat in the weft. Wooden teeth are set five per inch. Hard maple construction.

NUMBER	EACH	3/EA
A65018-1020	\$33.85	\$30.47



Loom Craft Tools

Create pom poms, tassels, braids, and much more. This multipurpose fiber craft tool has notches and arms to hold materials in place as you work, plus a center hole to keep projects from getting tangled. Made of poplar wood.

NUMBER	DESCRIPTION	SIZE	EACH	6/EA
A65131-1001	Big A Model	5"	\$13.17	\$11.85
A65131-1003	Robot Model	5"	13.17	11.85
A65131-1004	Slingshot XL Model	7"	15.72	14.15



Schacht® School Loom

Improves on the basic frame loom in several ways. It has sturdy construction, yet is lightweight enough for young students. It has a built-in stand that can be folded flat for storage, durable plastic warp spaces for uniform warping, and a 15" weaving width. Included are two pick-up sticks, weaving needle, and simple instructions.

NUMBER	EACH
A65011-0000	\$78.85



Schacht® Cricket Looms

Compact and capable, these portable looms are easy to take along. They're ideal for new weavers of any age and perfect for the classroom. Each loom includes an 8-dent reed, two stick shuttles, two balls of yarn, and more. Ratchet gears and ratchet dogs are located on the outside for easy tension adjustment. Choose a 10" or 15" weaving width. For more details, visit DickBlick.com.

NUMBER	SIZE	EACH
A65026-1001	10"	\$205.92
A65026-1015	15"	227.92



Nylon Loops

These stretchy nylon loops are great for your favorite hooking and crocheting projects. Available in assorted colors or vibrant neon colors. 16 oz packages.

NUMBER	DESCRIPTION	EACH	12/EA	36/EA
A65027-1008	Assorted	\$8.17	\$7.35	\$6.99
A65001-1106	Neon	8.68	8.16	7.72



Schacht® Lilli Loom

This solid hardwood loom has sturdy, no-slip plastic teeth that keep warp threads in place. Includes beater, stick shuttle, pick-up stick, shed stick, and weaving needle. 10" x 15".

NUMBER	EACH
A66914-1001	\$67.74

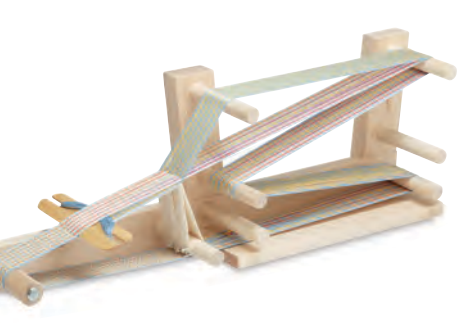

Schacht® Inkle Loom

Perfect for the classroom or for personal use, this inkle loom is not only durable but also easy to use. The 3/4" pegs are pressed and glued into 1" deep holes to withstand the tension typical of an inkle loom. Quick warping with the open sides (detailed instructions included). Warping is possible up to 8-1/2 feet long and 4-1/2" wide. Maintain perfect tension with sliding control bar. Made of solid maple, sanded and unfinished. 9-1/2"H x 31"W x 7"L. Shuttle not included.

NUMBER	EACH
A65007-0000	\$113.61



G-J Harrisville Designs LapLooms and Project Refill Kits

Learn basic weaving techniques on a portable tapestry loom. Each loom includes 1 oz of cotton warp string, six skeins of 100% pure virgin wool weft yarn, one tapestry needle, two shed sticks, one 6" stick shuttle, and instructions. Refill kits contain six skeins of 100% wool yarn, cotton warp string, and instructions.

NUMBER	DESCRIPTION	SIZE	EACH
A65290-1001	G LapLoom A	12" x 16"	\$50.87
A65290-1002	H LapLoom B	14-1/2" x 18-1/2"	61.47
A65290-1004	I Refill Kit, Mosaic		25.38
A65290-1003	J Refill Kit, Wildflower		25.38

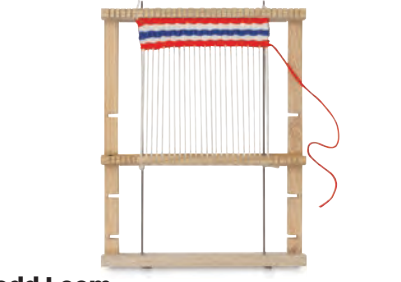

Todd Loom

Great for teaching the elementary principles of weaving without heddles, this loom includes a shuttle and instructions. It measures 10" x 12" with a maximum weaving width of 8-1/2". Choose an adjustable or a non-adjustable oak wood frame.

NUMBER	DESCRIPTION	EACH	12/EA
A65003-1103	Non-Adjustable	\$27.64	\$24.86
A65003-1003	Adjustable	40.58	36.50



Plastic Pot Holder Loom

Red plastic. 7" x 7". Includes instructions and weaving needle. Use with nylon loops (sold separately).

NUMBER	EACH	12/EA	36/EA
A65001-1001	\$2.97	\$2.68	\$2.53

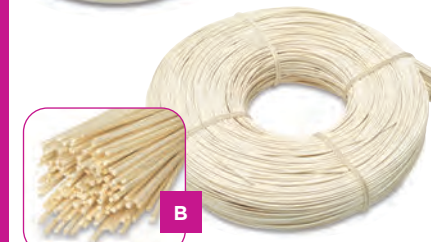
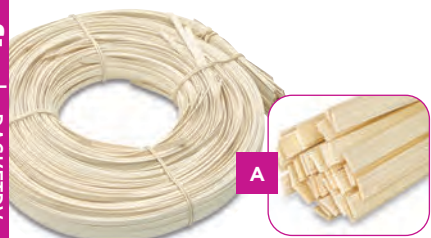

A-B Natural Reed for Basket Making

Soak in water 10 minutes before using.

A Flat Reed — 1 lb coil.

NUMBER	DESCRIPTION	EACH	10/EA
A60961-1326	1/4" (Approx 400 ft)	\$16.53	\$14.87
A60961-1336	1/2" (Approx 200 ft)	16.53	14.87
A60961-1038	3/8" (Approx 265 ft)	16.53	14.87

B Round Reed — 1 lb coil.

NUMBER	DESCRIPTION	EACH	10/EA
A60961-1376	#2, 1/16" (Approx 1100 ft)	\$16.53	\$14.87
A60961-1332	#3, 3/32" (Approx 750 ft)	16.53	14.87
A60961-1316	#4, 1/8" (Approx 500 ft)	16.53	14.87
A60961-1164	#6, 11/64" (Approx 200 ft)	16.53	14.87



Wood Basket Bases

Hardwood bases, drilled for #4 round reed.

NUMBER	DESCRIPTION	EACH	12/EA
A60417-1003	3" Round	\$1.14	\$9.99
A60417-1004	4" Round	1.49	1.35
A60417-1005	5" Round	1.82	1.64

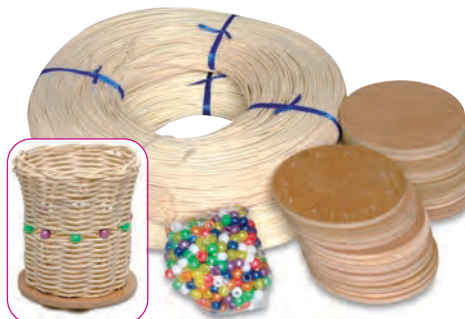

Basketry Kit

Classroom project kit includes enough #3 round reed, beads, and wooden bases to weave 25 baskets. For grades 4 through high school. Fully illustrated pattern sheet shows step-by-step procedure. Also useful for holiday gift making, scouts, and camp activities.

NUMBER	EACH	6/EA
A60900-1001	\$82.67	\$74.40



Coiling Core

Flexible, yet firm, quality paper core is perfect for making coiling baskets. Wrap with yarn, jute, and more for basic baskets.

NUMBER	DESCRIPTION	EACH	6/EA
A60962-1325	1/4"Dia x 180 ft Roll	\$15.42	\$13.88
A60962-1350	1/2"Dia x 100 ft Roll	22.03	19.83
A60962-1375	3/4"Dia x 50 ft Roll	25.34	22.81



Basketry Class Pack

This pack includes enough materials to make 30, 5"Dia coiled baskets, including 12, 4 oz skeins of yarn in assorted colors, braiding coiling core in three different diameters, 30 plastic needles, and an instruction booklet. The yarn colors may differ from those shown.

NUMBER	EACH	6/EA
A61789-1009	\$63.93	\$57.53



Cherokee Double-Wall Basketry Class Kit

This great classroom kit contains materials for making 40 traditional Cherokee double-wall baskets, each measuring approximately 4"H x 6"Dia. Traditional two-tone construction is made with #2 round natural reed and #2 smoked brown reed, which is frequently used by Cherokee weavers today. The Cherokee double-wall basket is known for its strength and durability, due to the two layers of weaving. Illustrated instructions are included.

NUMBER	EACH	3/EA
A61743-1009	\$84.27	\$75.84



Raffia

Fine-quality raffia from Madagascar. Useful for many floral, scrapbooking, basket making, and craft projects. Treating process prevents raffia from burning or mildewing. Moisturizer keeps fibers soft, supple, and easy to work with.

NUMBER	COLOR	EACH	12/EA
A60908-2052	Black	\$10.99	\$9.89
A60908-7052	Emerald Green	10.99	9.89
A60908-4882	Harbor Blue	10.99	9.89
A60908-8012	Medium Brown	10.99	9.89
A60908-1372	Natural	9.74	8.76
A60908-2982	Red	10.99	9.89
A60908-4022	Yellow	10.99	9.89

NUMBER	COLOR	EACH	12/EA
A60908-1005	Mixed Colors	\$8.38	\$7.54
A60908-1375	Natural	6.55	\$5.89



#18 Blunt Tapestry Needle — For medium yarns and raffia. Package of 12.

NUMBER	EACH	12/EA	24/EA
A66903-1009	\$2.17	\$1.95	\$1.85



Pepperell Crafts® Baskets and Things Classroom Pack

Explore the fascinating art of coiling. This pack includes enough material to make more than 30 coiled baskets (4"H x 5"Dia). Trays, coasters, and decorations can also be made from this pack. Includes 1,800 yd (48 oz) of assorted yarns in a variety of textures and 20 colors, including popular earth tones. Also includes 360 ft of 1/4"Dia coiling core, 30 blunt large eye needles, and easy-to-follow instructions and diagrams.

NUMBER	EACH	3/EA
A60962-1009	\$106.99	\$96.30

Roylco® Weaving Baskets Class Pack

Weave bright, rainbow patterned paper strips through beautiful baskets to make unique home and gift items. Pre-cut paper and an idea guide are included. Twelve baskets per pack in six bright colors. Economical, easy, and ideal for classrooms or community centers.

NUMBER	EACH	3/EA
A61426-1012	\$17.68	\$15.89



Hemptique® 20 lb Hemp Cord Spools & Cards

This 20 lb hemp cord is biodegradable and Earth-friendly. 205 ft spools.

NUMBER	COLOR	EACH	12/EA
A63830-2000	Black	\$6.63	\$5.97
A63830-8030	Dark Brown	6.63	5.97
A63830-3320	Dark Pink	6.63	5.97
A63830-2010	Earthy	6.63	5.97
A63830-7010	Green	6.63	5.97
A63830-4530	Orange	6.63	5.97
A63830-6000	Purple	6.63	5.97
A63830-3020	Red	6.63	5.97
A63830-5110	Turquoise	6.63	5.97
A63830-1000	White	6.63	5.97

20 lb Hemp Cord Cards — Four colors in 30 ft lengths. 120 ft total.

NUMBER	DESCRIPTION	EACH	12/EA
A62986-2030	Earthy Colors	\$6.27	\$5.65
A62986-2010	Earthy Pastels	6.27	5.65
A62986-1230	Spring Colors	6.27	5.65
A62986-1220	Vintage Colors	6.27	5.65



Hemptique® Hemp Twine

Hemp twine is an Earth-friendly, biodegradable alternative to synthetic cording for beading, jewelry making, scrapbooking, and crafts of all kinds. Choice of three weights, perfect for classroom projects.

NUMBER	DESCRIPTION	EACH	10/EA
A62985-1020	20 lb, 400 ft	\$7.05	\$6.34
A62985-1048	48 lb, 400 ft	9.35	8.42
A62985-1180	170 lb, 210 ft	14.72	13.25



Hippie Hemp™

Premium-quality hemp cord imported from Hungary especially for jewelry applications.

NUMBER	DESCRIPTION	EACH	6/EA
A61532-8221	20 lb, 38 ft, 1 mm	\$6.99	\$6.29
A61532-8222	48 lb, 300 ft, 2 mm	8.66	7.79
A61532-8223	170 lb, 175 ft, 3 mm	10.97	9.87



Invisible Ceiling Hooks

Just clip on the grid of a suspended ceiling and hang artwork, signs, mobiles, and more. Clear plastic, easy on and off. Package of two.

NUMBER	EACH	24/EA	48/EA
A57314-0009	\$2.17	\$1.95	\$1.85

Pepperell Cotton Macramé Cord

This soft, all-natural 2 mm cord has a traditional, twisted look and is easy to work with. Create wall hangings, knotted bracelets, and more. 100 ft long.

COLOR	2 MM, 100 FT	4 MM, 75 FT	6 MM, 50 FT
Black	A65285-2022	A65285-2024	A65285-2026
Blush Pink	A65285-3712	A65285-3714	A65285-3716
Charcoal	A65285-2132	A65285-2134	A65285-2136
Mint Green	A65285-7512	A65285-7514	A65285-7516
Natural	A65285-8452	A65285-8454	A65285-8456
Sky Blue	A65285-5072	A65285-5074	A65285-5076
White	A65285-1022	A65285-1024	A65285-1026
	EACH 12/EA	EACH 12/EA	EACH 12/EA
	\$4.90 \$4.40	\$5.45 \$4.90	\$6.54 \$5.89



Jute Twine

Natural unpolished jute twine is excellent for a variety of crafts as well as package wrapping. It is easy to handle and holds knots securely. Available in 2-ply, 3-ply, and 4-ply, plus the economical 10 lb ball of 4-ply twine.

NUMBER	DESCRIPTION	EACH	6/EA
A62984-8542	2-Ply, 338 ft	\$2.51	\$2.26
A62984-8543	3-Ply, 219 ft	2.51	2.26
A62984-8544	4-Ply, 162 ft	2.51	2.26
A62984-8540	4-Ply, 10 lb	30.03	27.03

Beadsmith Macramé Board

Keep macramé cords neat with this innovative board. It has specially designed notches that hold cords securely in place, and it has a smooth surface that won't snag cords. It's constructed from a lightweight, durable, self-healing foam board that's fully gridded.

NUMBER	DESCRIPTION	SIZE	EACH	6/EA
A73542-1001	Mini	7-1/2" x 10-1/2"	\$9.91	\$8.92
A73542-1002	Regular	11-1/2" x 15-1/2"	15.42	13.88



Wooden Dowel Rods

Birch dowel rods are perfect for a variety of craft projects, including wall hangings. In three popular diameters. Packs of 12.

NUMBER	DIAMETER	EACH	10/EA
A65292-1001	1"	\$.50	\$.40
A65292-1002	1-1/2"	.50	.40
A65292-1003	2"	.50	.40
A65292-1004	2-1/2"	.50	.40
A65292-1005	3"	.50	.40
A65292-1006	4"	1.14	.91
A65292-1007	5"	1.52	1.21
A65292-1008	6"	1.52	1.21
A65292-1009	8"	1.52	1.21
A65292-1010	10"	1.90	1.52
A65292-1011	12"	2.03	1.62
A65292-1012	14"	2.92	2.34
A65292-1014	16"	3.12	2.50

111 Piece Assortment — Includes 1/8" (34), 3/16" (20), 1/4" (17), 5/16" (15), 3/8" (13), and 1/2" (12).

NUMBER	EACH	6/EA
A60448-1111	\$52.94	\$47.64



A-F Suede Lace

Economical, sueded, split cowhide leather lacing features a soft surface and a firm temper.

NUMBER	COLOR	SIZE	EACH	12/EA
A63014-8141	A Beige	1/8" x 75ft	\$14.09	\$12.67
A63014-2021	B Black	1/8" x 75ft	14.09	12.67
A63014-8021	C Brown	1/8" x 75ft	14.09	12.67
A63014-5180	D Turquoise	3/32" x 6ft	2.61	2.35
A63014-2420	E Pewter	3/32" x 6ft	2.61	2.35
A63014-3010	F Red	3/32" x 6ft	2.61	2.35



G-L Deerskin Lace

Very soft, yet surprisingly strong full-grain leather lacing, ideal for jewelry and Native American crafts. Cuts evenly with minimal stretch. 1/8"W x 50 ft spools.

NUMBER	COLOR	EACH	12/EA
A63015-2020	G Black	\$20.93	\$18.79
A63015-8100	H Chocolate	20.93	18.79
A63015-9010	I Gold	20.93	18.79
A63015-8460	J Saddle Tan	20.93	18.79
A63015-5110	K Turquoise	20.93	18.79
A63015-1020	L White	26.23	23.61



Realeather Repair Needle Pack

A convenient assortment of five curved and straight needles suited for most stitching and repair jobs. Sized for thread, sinew, waxed thread, or cord.

NUMBER	EACH	6/EA
A62504-1003	\$6.54	\$5.89



Dreamcatcher Kit

Includes supplies for making eight Native American dreamcatchers, including 3" metal rings, suede lace, multicolored beads, artificial sinew, feather plumes, and instructions.

NUMBER	EACH	12/EA
A63010-1009	\$30.79	\$27.70



Leather Cord

Natural leather cord is ideal for stringing large-hole or natural beads or to showcase a favorite pendant. Can be easily knotted or braided. Use leather cord findings or make an adjustable knot to complete designs. Available in three colors in 5 meter spools.

NUMBER	DESCRIPTION	EACH	6/EA
A61517-2051	1.5 mm Black	\$5.19	\$4.67
A61517-8001	1.5 mm Brown	5.19	4.67
A61517-1351	1.5 mm Natural	5.19	4.67
A61517-2052	2 mm Black	5.19	4.67
A61517-8002	2 mm Brown	5.19	4.67
A61517-1352	2 mm Natural	5.19	4.67



Silver Creek Printed Leather Trim

These genuine leather strips are perfect for making small projects or adding color and texture to larger projects. Each strip is 9" x 3" — just the right size for cutting machines.

NUMBER	DESCRIPTION	EACH	12/EA
A62524-2020	Black Floral Embossed	\$6.60	\$5.94
A62524-2010	Kimono Black	6.60	5.94
A62524-4910	Marigold Natural	6.60	5.94
A62524-1001	Mini Leopard	6.60	5.94
A62524-1002	Paisley	6.60	5.94
A62524-9380	Platinum Crackle	6.60	5.94
A62524-9330	Silver Crackle	6.60	5.94



Realeather Leather Rotary Cutter

Easily cut leather, fabric, and paper with this razor-sharp rotary cutter. 38 mm blade with a locking safety guard. Comfortable cushioned grip.

NUMBER	EACH	6/EA
A62507-1001	\$9.90	\$8.91

Silvercreek Leather Punch Tools

Create punch details and designs easily. These sets include quality-made punch tools with solid steel handles and are designed to last a lifetime. Each set requires a mallet or maul (sold separately). For set contents, visit DickBlick.com.

NUMBER	DESCRIPTION	EACH	6/EA
A62521-1019	Maxi Punch Set	\$13.19	\$11.89
A62521-1009	Mini Punch Set	10.99	9.91
A62521-1039	Three Hole Stitching Punch	16.49	14.87



Realeather 20L Snap Setter Kit

Includes a setter, an anvil, and 20 light-duty snaps. The four-piece snaps are 1/2" in diameter. Perfect for thinner leathers (up to 4-5 oz), small cases, and garments.

NUMBER	EACH	6/EA
A62507-1002	\$9.42	\$8.48



Realeather Rivet Setter Kit

Includes a setter, an anvil, and 60 sets of assorted double-capped rivets. The rivets measure 1/4" and are designed to permanently join two or more pieces of leather.

NUMBER	EACH	6/EA
A62507-1003	\$9.42	\$8.48



Excel Aluminum Hobby Awl

Needle point awl makes holes or marks points in leather and paper. 5/16"Dia x 6"L.

NUMBER	EACH	12/EA
A28900-1000	\$4.11	\$3.69



Leather Stitching Needles

These large-eye, blunt-point needles are ideal for use with waxed thread or hemp. Package of 10.

NUMBER	EACH	6/EA
A63017-1001	\$4.11	\$3.71



First Quality Leather Hides

Top quality natural russet leather is ideal for tooling. Lightweight side is 3-4 oz, just right for small projects such as wallets, coin purses, and wall hangings.

NUMBER	DESCRIPTION	EACH
A60967-1370	Lightweight Side	\$257.63

Tooling Leather

Premium-grade cowhide tooling leather. Natural color.

NUMBER	SIZE	EACH	12/EA
A61598-1011	8-1/2" x 11"	\$14.32	\$12.89
A61598-1021	4-6 Square Feet	44.08	39.67



Realeather Leather Bracelet Blanks

Create your own leather jewelry. These bracelets are made of pre-finished 4-5 oz leather and measure 1-7/8" x 8".

NUMBER	DESCRIPTION	COLOR	SIZE	EACH	12/EA
A60598-2022	1 pk	Black	2"	\$3.31	\$2.98
A60598-8542	1 pk	Natural	2"	3.31	2.98
A60598-8232	1 pk	Tan	2"	3.31	2.98

2-Pack — Includes one piece of vegetable-tanned leather and one piece of pre-finished 4-5 oz leather each measuring 3/4" x 8".

NUMBER	DESCRIPTION	COLOR	SIZE	EACH	12/EA
A60598-8551	2 pk	Natural/Tan	1"	\$2.61	\$2.35



Realeather Leather Strips

These narrow, pre-finished, and oil-tanned 5-6 oz pieces are ideal for straps, handles, accessories, and repair work. They measure 1/2" x 36".

NUMBER	COLOR	EACH	12/EA
A62506-8006	Black	\$5.90	\$5.31
A62506-2026	Brown	5.90	5.31



Premium Leather Remnants

These multicolored assortments of lightweight leather remnants are great for making small pouches and purses. Also use in trims, scrapbooking, and bookmaking. May include full-grain and suede leathers, all of 4 oz thickness or less. Assortments will vary.

NUMBER	DESCRIPTION	EACH	12/EA
A61706-1001	1 lb Assortment	\$9.91	\$8.92



SilverCreek Credit Card Wallet Kit

A classic wallet with six credit card slots and a bill compartment that's ready to be customized. Includes un-punched premium tooling leather, pre-finished liner parts, and step-by-step instructions. Measures 9-3/8"L x 3-1/2"W when open.

NUMBER	EACH	6/EA
A62519-1004	\$27.55	\$24.79

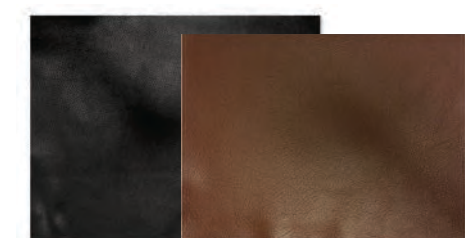

Realeather Premium Trim Leather

An excellent choice for leather crafters interested in small accessories requiring a lighter, more pliable leather. Economically sized 8-1/2" x 11" pieces of 3-4 oz soft cowhide. Pre-finished and ready to use.

NUMBER	COLOR	EACH	6/EA
A62509-2021	Black	\$13.22	\$11.89
A62509-8001	Brown	13.22	11.89



Silver Creek Envelope Clutch Kit

A smart leather clutch with a button stud closure and removable strap. Personalize it with punch details, stitching, and more. Kit includes un-punched premium tooling leather parts, all hardware, and step-by-step instructions. 8-1/2"H x 10-3/4"W.

NUMBER	EACH	6/EA
A62519-1005	\$28.65	\$25.78



Angelus Leather Dye

This heavily pigmented dye is guaranteed to penetrate leather. It forms lasting color that won't peel, crack, or wash off. A popular dye for sneaker restoration. Also great for coloring belts, purses, wood, and other custom projects. 3 oz (88.7 ml) bottles. Wood dauber included.

NUMBER	COLOR	EACH
A64932-5013	Blue	\$5.18
A64932-7013	Green	5.18
A64932-4413	Honey	5.18
A64932-2083	Jet Black	5.18
A64932-5043	Navy Blue	5.18
A64932-2543	Neutral	5.18
A64932-4513	Orange	5.18
A64932-3433	Oxblood	5.18
A64932-6003	Purple	5.18
A64932-3013	Red	5.18
A64932-5113	Turquoise	5.18
A64932-4013	Yellow	5.18



M Silver Creek Travel Journal Kit

This kit includes a pre-cut, pre-punched leather cover and tab, elastic cords, instructions, and one package each of three paper inserts — calendar, grid, and sketch paper. Dye, color, paint, and add a protective leather finish. Fits refill sizes up to 8-1/4"H x 4-1/3"W.

NUMBER	EACH	6/EA
A62519-1001	\$20.78	\$18.70

N Realeather Fringe

This versatile fringe comes in 2" x 3" pieces. The individual fringe strands are 1/8" wide. Two pieces of fringe per card.

NUMBER	COLOR	EACH	6/EA
A62505-1033	Black	\$3.82	\$3.44
A62505-1013	Gold	3.82	3.44
A62505-1023	Gunmetal	3.82	3.44

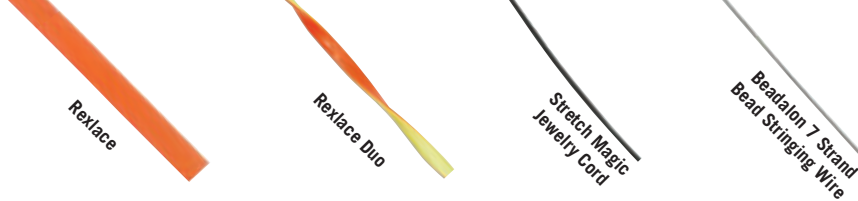

For more Rexlace colors, visit DickBlick.com.

Rexlace®
Extruded 3/32" flat lacing. Minimum stretch, pliable, non-flammable. 100 yd spools.

NUMBER	COLOR	EACH	5/EA	25/EA
A60921-2100	Black	\$3.19	\$2.87	\$2.73
A60921-4260	Canary	3.19	2.87	2.73
A60921-4050	Gold Sparkle	3.19	2.87	2.73
A60921-7000	Green	3.19	2.87	2.73
A60921-5010	Light Blue	3.19	2.87	2.73
A60921-5300	Neon Blue	3.19	2.87	2.73
A60921-7770	Neon Green	3.19	2.87	2.73
A60921-4680	Neon Orange	3.19	2.87	2.73
A60921-3000	Red	3.19	2.87	2.73
A60921-5050	Royal Blue	3.19	2.87	2.73
A60921-2240	Silver Sparkle	3.19	2.87	2.73
A60921-1100	White	3.19	2.87	2.73

Stretch Magic® Jewelry Cord
Popular elastomer jewelry cord! Strong, durable, and non-fraying, Stretch Magic offers great elasticity and resiliency, making jewelry easy to wear and remove. Excellent crimping strength.

Cord — 82 ft long spools.

NUMBER	DESCRIPTION	EACH	6/EA
A61527-2055	Black, 0.5 mm	\$8.73	\$7.86
A61527-2051	Black, 1.0 mm	8.73	7.86
A61527-1605	Clear, 0.5 mm	8.73	7.86
A61527-1601	Clear, 1.0 mm	8.73	7.86

Nylon Jewelry Cord
The perfect size for threading many of the smaller to medium-sized beads. Braided 1/16" Dia colorfast nylon is heat-fusible. 25 yd spools.

NUMBER	COLOR	EACH	12/EA
A60616-2025	Black	\$4.62	\$4.15
A60616-1025	White	4.62	4.15

Beadalon® 7 Strand Bead Stringing Wire
This fine-diameter, seven-strand stainless steel wire has a thin, smooth, kink-resistant nylon coating. Strong, soft, and flexible, it's the first choice of professional jewelry designers. 30 ft spools.

NUMBER	COLOR	SIZE	EACH	12/EA
A60636-2020	Black	0.38 mm	\$3.43	\$3.08
A60636-4020	Gold	0.38 mm	7.99	7.20
A60636-4030	Gold	0.46 mm	8.39	7.55
A60636-2240	Satin Gold	0.38 mm	4.59	4.13
A60636-2450	Satin Silver	0.38 mm	4.59	4.13
A60636-2400	Silver	0.38 mm	3.43	3.08
A60636-2410	Silver	0.46 mm	8.39	7.55
A60636-1020	White	0.38 mm	3.43	3.08

Creativity Street® Elastic Cord
The economical choice for every crafter's supply box. 25 yd cards.

NUMBER	COLOR	EACH	12/EA
A61594-1025	White	\$8.10	\$7.25
A61594-2025	Black	8.10	7.25

Necklaces & Bracelets — Black. Necklaces are 16-1/2" long. Bracelets are 7-1/4" long. Clasps included.

NUMBER	DESCRIPTION	EACH	6/EA
A61528-2056	Necklace 6-Pack	\$5.23	\$4.70
A61528-1006	Bracelet 6-Pack	5.23	4.70



John Bead Craft Paracord
Make bracelets, zipper pulls, pet accessories, and other DIY projects with this durable, round polyester cord. It's 1/8" (4 mm) in diameter and comes in 16 ft (4.8 m) lengths.

NUMBER	COLOR	DIAMETER	LENGTH	EACH	6/EA
A63889-2024	Black	1/8"	16ft	\$3.91	\$3.52
A63889-7774	Neon Green	1/8"	16ft	3.91	3.52
A63889-6004	Purple	1/8"	16ft	3.91	3.52
A63889-3014	Red	1/8"	16ft	3.91	3.52
A63889-9334	Silver	1/8"	16ft	3.91	3.52
A63889-1024	White	1/8"	16ft	3.91	3.52



John Bead Craft Paracord Buckles
Use these plastic buckles to finish your paracord bracelets and other DIY craft projects.

NUMBER	COLOR	SIZE	PKG	EACH	6/EA
A63895-1006	Assorted Colors	12 mm	6	\$3.83	\$3.44
A63895-1005	Assorted Colors	15 mm	5	3.83	3.44
A63895-2026	Black	12 mm	6	3.57	3.22
A63895-2025	Black	15 mm	5	3.57	3.22



Beadalon® Thing-A-Ma-Jig
Elaborate wire designs — including jewelry components, necklace links, ornaments, and more — can be replicated again and again with this sturdy, economical jiggling tool. Designed to resist peg deformities even after prolonged use. Aluminum. Includes instruction booklet.

NUMBER	DESCRIPTION	SIZE	EACH	6/EA
A60638-1000	Deluxe	4" x 5"	\$20.79	\$18.73

Beginner Thing-A-Ma-Jig — The perfect introduction to light-duty wire jiggling, it works best with smaller-gauge wires (20–28 gauge). Includes instruction booklet. Plastic. 3" x 4".

NUMBER	DESCRIPTION	SIZE	EACH	6/EA
A60638-2000	Beginner	3" x 4"	\$5.95	\$5.35



Beadsmith Metal Knotting Awl
Create consistent, tight knots for jewelry projects. Form knots between beads and pearls, and open small beads to cover crimps. This awl also guides knots down to be as close to the bead as possible. Its fine point helps loosen knots and tangles.

NUMBER	DESCRIPTION	SIZE	EACH	6/EA
A73541-1001			\$1.73	\$1.56



A Metallic Copper Wire Packs
Each pack contains six spools of wire. The Silver and Gold packs contain three 15 ft spools of each color. The Silver, Gold, and Copper pack contains two 15 ft spools of each color. Select from three gauges.

NUMBER	DESCRIPTION	EACH	6/EA
A60688-1022	22 Gauge Silver/Gold	\$17.58	\$15.82
A60688-1024	24 Gauge Silver/Gold	13.18	11.86
A60688-1026	26 Gauge Silver/Gold	13.07	11.76
A60688-2022	22 Gauge Copper/Slv/Gld	13.81	12.43
A60688-2024	24 Gauge Copper/Slv/Gld	13.82	12.44
A60688-2026	26 Gauge Copper/Slv/Gld	12.93	11.64

B Silver-Plated Copper Wire
High-quality, silver-plated copper wire. Each pack contains 15 ft long spools of six different colors: Peacock Blue, Rose, Seafoam Green, Tangerine, Lemon, and Amethyst.

NUMBER	SET	EACH	6/EA
A60687-1229	6 Colors, 22 Gauge	\$21.71	\$19.55
A60687-1249	6 Colors, 24 Gauge	15.72	14.15
A60687-1269	6 Colors, 26 Gauge	13.78	12.40

C Colored Copper Wire
Economical pack contains 15 ft long spools of Black, Dark Blue, Green, Purple, Red, and Tinned Copper.

NUMBER	SET	EACH	6/EA
A60689-1229	6 Colors, 22 Gauge	\$9.82	\$8.66
A60689-1249	6 Colors, 24 Gauge	8.76	7.73
A60689-1269	6 Colors, 26 Gauge	6.13	5.41



Nickel Silver Wire
An economical substitute for sterling silver. Alloy contains 18% nickel, 65% copper, and 17% zinc. 20 gauge.

NUMBER	DESCRIPTION	EACH	6/EA
A61599-1001	1 lb Spool, 315 ft	\$49.59	\$44.63



Set of 3 Jewelry Tweezers
Quality forged steel tools designed for crafts and jewelry making.

NUMBER	DESCRIPTION	EACH	24/EA
A60619-0000		\$4.36	\$3.92



D Beadalon® Crimper
This crimper leaves a smooth, round bead and eliminates sharp edges. It features a lower position that crimps as the upper position rounds for a clean, professional look.

NUMBER	EACH	6/EA
A60629-1001	\$11.09	\$9.98

E Beadalon® Memory Wire Shear
Specially designed for cutting spring-tempered hard wire like Beadalon's Remembrance™ or jewelry cable, this shear features hardened 90° jaws that slice effortlessly through wire and leave a safe, clean, straight edge.

NUMBER	EACH	6/EA
A60629-1003	\$25.11	\$22.60

F Beadalon® Nipper Tool
This nipper cuts a wide variety of soft materials, including jewelry wire and cord. Angled blades shear lines without fraying and leave a smooth edge. Not for use with hard wires or spring-tempered material.

NUMBER	EACH	6/EA
A60629-1002	\$9.85	\$8.85



Beadalon Artistic Wire Aluminum Craft Wire
Soft, tempered wire perfect for wire wrapping. It's permanently colored and perfect for making cuff bracelets and other beading projects. Thick, lightweight, and easy to bend.

NUMBER	COLOR	THICKNESS	LENGTH	EACH	4/EA
A63845-8452	Aluminum, Natural	12 Gauge	39 ft	\$5.77	\$5.19
A63845-8002	Brown, Aluminum	12 Gauge	39 ft	5.77	5.19
A63845-9075	Antique Brass	22 Gauge	45 ft	4.21	3.78
A63845-9525	Tinned Copper	22 Gauge	45 ft	4.21	3.78
A63845-9095	Brass, Tarnish Resistant	22 Gauge	45 ft	4.21	3.78
A63845-9505	Copper	22 Gauge	45 ft	4.21	3.78
A63845-5165	Aqua	22 Gauge	45 ft	4.21	3.78
A63845-1010	Stainless Steel	28 Gauge	120 ft	7.17	6.45
A63845-2024	Black	18 Gauge	12 ft	4.03	3.63
A63845-2025	Black	22 Gauge	45 ft	4.21	3.78
A63845-2020	Black	28 Gauge	120 ft	7.17	6.45



Beadalon Pliers
These pliers are useful for a variety of beadwork, jewelry making, and craft applications for professionals and novices alike. They can be used for gripping, cutting, and crimping wire, making loops, picking up small items, accessing tight areas, and more.

NUMBER	DESCRIPTION	EACH	6/EA
A60671-1009	Bent Chain Nose	\$10.38	\$9.35
A60671-1001	Chain Nose	10.38	9.35
A60671-1008	Combo	14.35	12.92
A60671-1002	Flat Nose	10.38	9.35
A60671-1010	Flat/Round	7.49	6.74
A60671-1006	Rosary	8.29	7.47
A60671-1004	Round Nose	9.31	8.38
A60671-1007	Wire Looping	13.29	11.96
A60671-1011	Tool Kit, 3pc	19.66	17.69



Forged Steel Jewelry Pliers
Quality forged steel, spring-action pliers are designed for jewelry making and general crafting. 4-1/2" long.

NUMBER	DESCRIPTION	EACH	10/EA
A60618-1245	Long Nose	\$4.36	\$3.92
A60618-1145	Round Tip	4.36	3.92
A60618-1045	Side Cutter	4.36	3.92



G-H Mini Long-Nose Pliers and Mini Wire Cutters
Great quality at a value price. 5" spring-loaded, long-nose steel pliers and 5" steel mini wire cutters both have padded blue rubber handles for easy gripping. Perfect for small jobs, beading, and dozens of other uses around the home and studio.

NUMBER	DESCRIPTION	EACH	12/EA
A33083-1010	Mini Pliers	\$6.07	\$5.45
A33083-1020	Mini Wire Cutters	6.07	5.45



Craft Plier Set
Our most economical set! Five-piece floral and craft steel plier set includes everything you need to be creative: round tip, diagonal, flat nose, bent nose, and long nose.

NUMBER	EACH	6/EA
A33064-1069	\$21.27	\$19.14

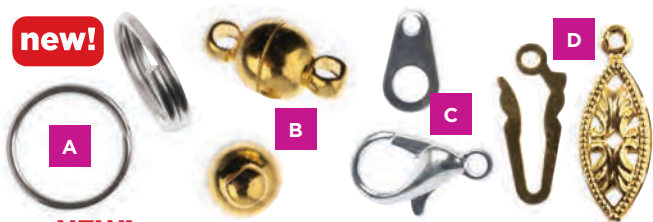

A-D NEW! John Bead Must Have Jewelry Findings
Complete any project perfectly with split rings, magnetic clasps, lobster clasps, and fish hook clasp sets. Split rings come in a gleaming Silver finish. Clasps are available in Gold and Silver finishes. All are free of lead and nickel.

Split Rings					
NUMBER	COLOR	SIZE	PKG OF	EACH	6/EA
A80981-9332	A Silver	6 mm	142	\$3.73	\$3.35
A80981-9333	Silver	10 mm	100	3.73	3.35
Round Magnetic Clasps					
NUMBER	COLOR	SIZE	PKG OF	EACH	6/EA
A80981-9335	Silver	6 x 6.5 mm	2	\$4.72	\$4.25
A80981-9013	B Gold	6 x 6.5 mm	2	4.72	4.25
Lobster Clasps					
NUMBER	COLOR	SIZE	PKG OF	EACH	6/EA
A80981-9336	C Silver	12 mm	10	\$4.72	\$4.25
A80981-9014	Gold	12 mm	10	4.72	4.25
Fish Hook Clasps					
NUMBER	COLOR	SIZE	PKG OF	EACH	6/EA
A80981-9337	Silver	6 x 20 mm	9	\$7.47	\$6.73
A80981-9015	D Gold	6 x 20 mm	9	7.47	6.73



E-K NEW! John Bead Jewelry Finding Kits

Choose from earwires, jump rings, eye pins, bead caps, head pins, clamp ends, and earring mixes. Findings come in assorted finishes, including Gold, Brass, and Silver. Pieces are housed in a reusable container.

NUMBER	DESCRIPTION	PKG OF	EACH	6/EA
A80964-1001	E Earwires	240	\$6.59	\$5.93
A80964-1002	F Jump Rings	1200	7.03	5.93
A80964-1003	G Eye Pins	1000	7.25	6.53
A80964-1004	H Bead Caps	1020	8.57	7.71
A80964-1005	I Head Pins	1030	7.03	6.33
A80964-1006	J Clamp Ends	138	7.14	6.43
A80964-1007	K Earring Mix	80	10.22	9.20



Impress Art Stamping Blanks

The perfect canvas for your stamping art! Use these aluminum shapes for hand-stamped jewelry projects of all kinds.

NUMBER	DESCRIPTION	COLOR	SIZE	EACH
A63841-1022	Bracelet	Aluminum	3/8" Width	\$10.60
A63841-1017	3-D Rectangle, Pkg of 4	Aluminum	1-1/2" x 1/4"	6.36
A63841-1032	N Rectangle w/Holes Pkg of 10	Copper	1/4" x 1 1/2"	6.36



NEW! ImpressArt Basic Hand Stamping Kit

Includes everything you need to hand stamp jewelry and more! Ideal for use with a variety of metals, including gold, silver, aluminum, copper, brass, and pewter. It comes with a soft steel hammer for making deep, even impressions, plus a stamping block, stamping guides, stamp enamel for darkening stamped impressions, and the materials for four keychain projects. For set contents, visit DickBlick.com.

NUMBER	EACH
A65133-1002	\$54.99



ImpressArt Bracelet Bending Bar Kit

Easily create metal bracelets. Kit includes a Bracelet Bending Bar and seven 14-gauge aluminum Bracelet Stamping Blanks (5/8" x 6").

NUMBER	EACH
A63841-1024	\$16.50



ImpressArt Tools

Use to stamp impressions into metal, punch holes, or bend wire for a variety of jewelry projects.

NUMBER	DESCRIPTION	EACH
A63837-1006	Steel Block	\$13.99
A63837-1007	Stamping Hammer	23.32
A63837-1001	Hole Punch Pliers	16.54
A63837-1009	Chain Nose Pliers	9.33

John Bead Poly Cotton Tassels

Made of poly/cotton thread, these stylish jewelry components are great for jazzing up earrings, belts, bags, key fobs, and more. Packages include four, 1" long tassels.

NUMBER	COLOR	EACH	6/EA
A73517-2021	Black	\$2.04	\$1.84
A73517-1201	Black and Grey	2.04	1.84
A73517-1001	Black and Ivory	2.04	1.84
A73517-2501	Grey	2.04	1.84
A73517-1041	Ivory	2.04	1.84
A73517-3011	Red	2.04	1.84
A73517-1301	Rosewater and Fuchsia	2.04	1.84

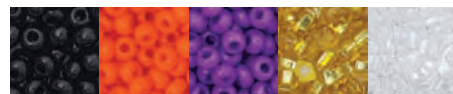

John Bead Czech Glass Seed Beads

Made of quality Czech glass, these colorful beads are perfect for making jewelry and embellishing DIY craft projects. Beads are size 10/0 and are packaged in 22 g tubes.

NUMBER	COLOR	STYLE	EACH	6/EA
A63842-4512	Orange	Opaque	\$4.40	\$3.96
A63842-2022	Black	Opaque	4.40	3.96
A63842-6062	Violet	Opaque	4.40	3.96
A63842-9012	Gold	Silver Lined	4.40	3.96
A63842-8802	Crystal	Clear	4.40	3.96

Santa Fe Patchwork



Bologna City

John Bead Czech Glass Bead Box Mixes

Each box in this collection is color-themed with different shapes, sizes, and colors inside. The beads are made of quality Czech glass, and each box is approximately 200 g.

NUMBER	DESCRIPTION	EACH	6/EA
A65096-1132	The Amazon	\$15.66	\$14.09
A65096-1202	Bologna City	15.66	14.09
A65096-1102	Dazzling Sidewalk	15.66	14.09
A65096-1192	Gold Gravel	15.66	14.09
A65096-1122	Santa Fe Patchwork	15.66	14.09

For more John Bead Czech Glass Beads, visit DickBlick.com.



Big Kid Bead Assortment

Big glass beads with big round holes are great for young artists with small hands! This economical assortment contains 1 lb of beads in a fun variety of sizes, shapes, colors, and patterns.

NUMBER	EACH	12/EA
A60792-1001	\$11.59	\$10.44



Assorted Plastic Beads

Big bargain tub of plastic beads in assorted styles and colors. 10-12 oz mix.

NUMBER	EACH	12/EA
A60716-1005	\$7.08	\$6.37



John Bead Plastic Bead Mixes

These colorful assortments of plastic beads are packaged in lightweight plastic tubs with a resealable lid and handle. Choose from a 1,000 assorted pony beads or 870 assorted spaghetti beads.

NUMBER	DESCRIPTION	SIZE	EACH	10/EA
A63890-1001	Spaghetti Bead Mix	19 mm x 6 mm beads	\$13.42	\$12.07
A63890-1002	Pony Bead Mix	9 mm beads	11.53	10.38



Fancy Glass Bead Mix

An exotic mix of lampwork glass beads in assorted colors and shapes, many featuring metallic swirls and elaborate surfaces. Add accents to solid bead designs or make eclectic jewelry. 10-26 mm. 1 lb.

NUMBER	EACH	10/EA
A61520-1001	\$19.89	\$17.89



L-CC John Bead Euro Wood Beads

Made of high-quality European hardwoods from maple, beech, and hornbeam trees. Perfect for embellishing weaving projects, accessories, home décor items, and more.

Flat Oval

NUMBER	COLOR	PKG	EACH	6/EA
A63894-2020	L Black	50	\$4.62	\$4.17
A63894-8030	M Dark Brown	50	4.62	4.17
A63894-8502	N Mahogany	100	5.95	5.36

Round — 8 mm beads in packages of 100.

NUMBER	COLOR	EACH	6/EA
A63894-2028	O Black	\$5.10	\$4.58
A63894-8038	P Dark Brown	5.10	4.58
A63894-8508	Q Mahogany	5.10	4.58
A63894-8458	R Natural	5.21	4.68
A63894-5118	S Turquoise	5.62	5.06

Round Large Hole — 8 mm x 9.8 mm beads in packages of 100.

NUMBER	COLOR	EACH	6/EA
A63894-2025	Y Black	\$5.36	\$4.81
A63894-8035	Z Dark Brown	5.36	4.81
A63894-8505	AA Mahogany	5.36	4.81
A63894-8455	BB Natural	5.36	4.81
A63894-5115	CC Turquoise	5.94	5.35



Venetian Glass Beads

Modern replicas of 19th century Millefiori Venetian glass beads in a variety of colorful patterns and intriguing shapes. Every bead is totally unique. Sizes range from 1/2" to 1" diameter. 8 oz assortment contains approximately 25-30 beads; 1 lb assortment approximately 50-60 beads.

NUMBER	DESCRIPTION	EACH	12/EA
A61549-1008	8 oz	\$6.97	\$6.27
A61549-1001	1 lb	13.98	12.58

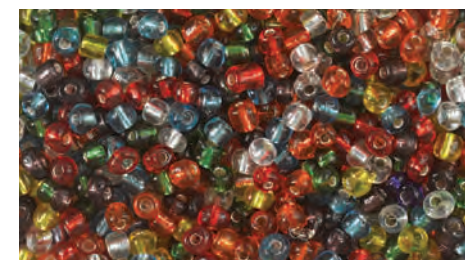

Rocaille E Beads

These colorful clear glass beads have a metallic silver lining that creates a shimmering effect. The assortment contains 8 oz of beads measuring approximately 4 mm in size.

NUMBER	EACH	12/EA
A60795-1005	\$7.52	\$6.76



Creativity Street Pony Beads

Create colorful necklaces, bracelets, key chains, and more. Packages include 1,000 6 mm x 9 mm beads.

NUMBER	COLOR	EACH	12/EA
A73528-2020	Black	\$9.18	\$8.26
A73528-8000	Brown	9.18	8.26
A73528-5010	Blue	9.18	8.26
A73528-7010	Green	9.18	8.26
A73528-4510	Orange	9.18	8.26
A73528-3060	Pink	9.18	8.26
A73528-6000	Purple	9.18	8.26
A73528-3010	Red	9.18	8.26
A73528-1020	White	9.18	8.26
A73528-4010	Yellow	9.18	8.26



Essentials by Leisure Arts Pony and Alphabet Mixed Beads

Featuring large holes that allow for easy and convenient stringing. Each 1 lb assortment contains a variety of opaque pony beads and white alphabet beads.

NUMBER	WEIGHT	EACH	6/EA
A80948-1001	1 lb	\$14.29	\$12.85



Assorted Metallized Beads

Beautiful metallized colors in a value assortment. Wide variety of designs and shapes. Use in jewelry making, altered art, collage, and much more.

NUMBER	DESCRIPTION	EACH	12/EA
A60776-1008	8 oz	\$15.93	\$14.33
A60776-1001	1 lb	22.03	19.83



Krafty Kids Natural Wood Beads

Includes 1.4 oz (40 grams) of wood beads in a variety of sizes.

NUMBER	EACH	12/EA
A80909-1007	\$3.78	\$3.40

new!

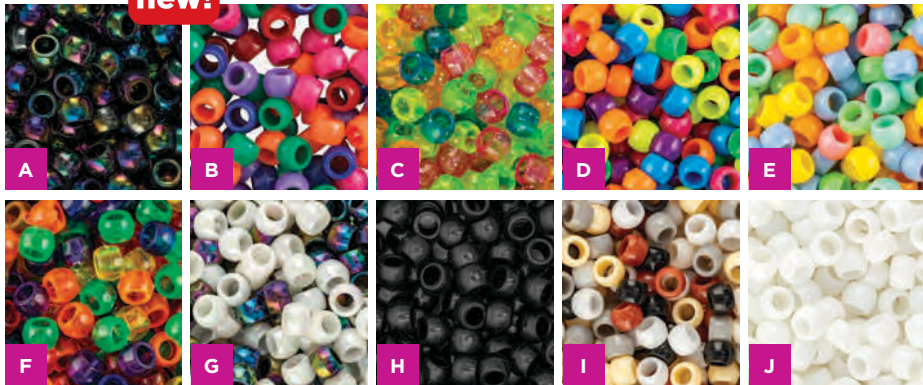

A-J NEW! Essentials by Leisure Arts Pony Beads

Featuring a glossy finish, choose from an array of colors. Large holes make them easy to string. Each package contains 750 pony beads measuring approximately 1/4" x 11/32" (6mm x 9 mm) with a 13/32" (4mm) hole.

NUMBER	COLOR	EACH	6/EA	NUMBER	COLOR	EACH	6/EA
A80947-2020	A AB Black	\$5.49	\$4.95	A80947-1010	F Transparent Mix	\$5.49	\$4.95
A80947-1070	B Bold Mix	5.49	4.95	A80947-1060	G Neutral AB	5.49	4.95
A80947-1050	C Glitter Mix	5.49	4.95	A80947-2000	H Neutral Black	5.49	4.95
A80947-1020	D Neon Mix	5.49	4.95	A80947-1040	I Neutral Mix	5.49	4.95
A80947-1030	E Pastel Mix	5.49	4.95	A80947-1080	J Neutral White	5.49	4.95



Clay Bead Assortments

Beautiful assortments feature a unique variety of colors, intriguing textures, and artistic shapes. Sizes range from 1/4" to 3/4" (but may vary). The 8 oz assortment contains approximately 100-105 beads. The 1 lb assortment contains approximately 200-210 beads.

NUMBER	WEIGHT	EACH	3/EA
A61547-1008	8 oz	\$9.91	\$8.91



Essentials By Leisure Arts Alphabet Beads

These opaque beads are ideal for a wide variety of craft projects, bracelets, necklaces, and other jewelry.

NUMBER	DESCRIPTION	SIZE	PKG OF	EACH	6/EA
A80942-1006	Black & White Circle	7 mm	250	\$6.59	\$5.93
A80942-1017	Black & White Square	7 mm	250	6.59	5.93
A80942-1006	Colored Square	6 mm	150	6.59	5.93



Krafty Kids Unfinished Wood Beads

Excellent for crafting or adding detail to a variety of beading projects. Varying sizes and shapes.

NUMBER	STYLE	PKG OF	EACH	12/EA
A80909-1001	Fancy	28	\$2.88	\$2.59
A80909-1005	Round	13	2.59	2.33
A80909-1003	Round	60	2.59	2.33



Creativity Street Wood Beads

Durable wooden beads ideal for jewelry making, toy design, decorations, and creative accents. Each 1 lb resealable bag contains a variety of colors, shapes, and sizes.

NUMBER	WEIGHT	EACH	6/EA
A80937-1001	1 lb	\$23.69	\$21.32



Creativity Street Bead Loom Kit

This all-inclusive kit contains a 3"H x 4-1/2"W x 1/4"D durable metal loom, multicolored seed beads, beading string, two needles, and easy-to-follow instructions. Weaves bead or yarn projects up to 2-1/2" wide.

NUMBER	EACH	12/EA
A65022-1001	\$12.30	\$11.07

K Creativity Street Spiral Chenille Stems

The unique shape of the Creativity Street Spiral Chenille Stems will add dimension, texture, and color to your craft projects in the classroom and at home. Bend and twist them to create any shape, or turn them into an animal or creature of your own imagination. Embellish them with beads, wiggle eyes, and other craft accessories. This package of 50 includes an assortment of Purple, Pink, Blue, and Green 1/2"W x 12"L stems.

NUMBER	EACH	10/EA	50/EA
A60923-1001	\$3.23	\$2.89	\$2.76

L Creativity Street Bump Stems

Chenille stems with a new look! Stems have four bumps per stem, creating many different effects. Available in an assortment of favorite colors. Stems are 12" long and come in a package of 48. Ideal instruction book included.

NUMBER	EACH	12/EA	24/EA
A61162-1012	\$4.45	\$4.04	\$3.83

M Creativity Street Stems

Bundles of 100 in assorted colors. Choose 6" or 12" length. 4 mm wide.

NUMBER	DESCRIPTION	EACH	10/EA	50/EA
A60923-1006	6" Assorted	\$1.97	\$1.78	\$1.69
A60923-1012	12" Assorted	2.39	2.16	2.05

Creativity Street Stems Bundle Packs

100 per pack. 4 mm x 12" long.

NUMBER	COLOR	EACH	10/EA	50/EA
A60923-2022	Black	\$2.39	\$2.16	\$2.05
A60923-8002	Brown	2.39	2.16	2.05
A60923-5032	Dark Blue	2.39	2.16	2.05
A60923-7392	Kelly Green	2.39	2.16	2.05
A60923-4502	Orange	2.39	2.16	2.05
A60923-3062	Pink	2.39	2.16	2.05
A60923-5622	Purple	2.39	2.16	2.05
A60923-2052	Red	2.39	2.16	2.05
A60923-1042	White	2.39	2.16	2.05
A60923-4022	Yellow	2.39	2.16	2.05

N Chenille Kraft Big Box

Contains 150 jumbo multicolored stems with idea book included. 6 mm x 12" long.

NUMBER	EACH	12/EA	24/EA
A61466-1001	\$8.52	\$7.64	\$7.27

O Creativity Street Striped Stems

Bundle of 100 assorted colors. 6 mm x 12" long.

NUMBER	EACH	10/EA	50/EA
A60923-1023	\$4.77	\$4.28	\$4.07

P Creativity Street Tinsel Stems

Bundle of 100 assorted colors. 6 mm x 12" long.

NUMBER	EACH	10/EA	50/EA
A60923-0009	\$4.43	\$3.99	\$3.79

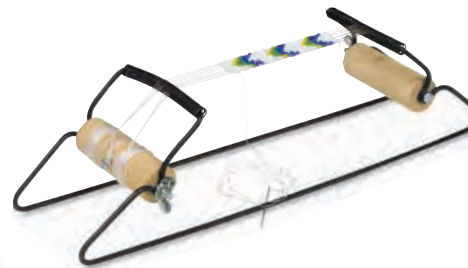

Creativity Street Peel & Stick Pom Poms

Easily add color, texture, and dimension to your craft projects. All you have to do is peel and stick — no glue needed! Packages include three sheets of eighty high-quality, plush round pom poms, including ten each of White, Pink, Purple, Blue, Yellow, Orange, Green and Red per sheet. Each package contains a total of 240 pom poms.

NUMBER	EACH	6/EA	12/EA
A62185-1001	\$11.26	\$10.12	\$9.62



Craft Buttons

One full pound of buttons in an assortment of colors, sizes, and designs. For general craft work. Great for collage, stuffed toys and puppets, mask decoration, card making, and much more! Assortment will vary.

NUMBER	EACH	5/EA
A61495-1001	\$6.45	\$5.80



Creativity Street Super Colossal Stems

These hefty craft stems measure 18"L x 1"Dia. Packs contain 24 stems in assorted colors.

NUMBER	EACH	6/EA	12/EA
A61783-1024	\$21.85	\$19.66	\$18.68

Did you know we have hundreds of lesson plans designed to meet the National Standards for Visual Arts Education? See them all at DickBlick.com/lesson-plans.



Maribou Feathers

Brilliant colors and a fluffy texture make these feathers unique. 0.5 oz bag contains approximately 125 feathers.

NUMBER	EACH	12/EA
A61404-1010	\$3.58	\$3.21



Creativity Street Plumage Feathers

Each .5 oz (14 g) bag includes an assortment of turkey plumage in a variety of colors and sizes ranging from 2" to 5". Glue or tape these non-toxic feathers to collages, masks, and other mixed media creations.

NUMBER	COLOR	SIZE	EACH	12/EA
A83727-1021	Bright	1 oz	\$5.95	\$5.35
A83727-1001	Hot	1/2 oz	2.63	2.35
A83727-1011	Natural	1/2 oz	2.63	2.35



Duck Quills

Brightly dyed duck quill feathers come in assorted sizes and colors.

NUMBER	DESCRIPTION	EACH	12/EA
A61199-1001	0.5 oz bag	\$4.21	\$3.78
A61199-1003	3 oz bag	18.46	16.61



Creativity Street Pom Pons

Each package contains 100 soft, crush-resistant 1" Pom Pons perfect for a variety of craft applications.

NUMBER	COLOR	EACH	12/EA
A65364-2020	Black	\$4.85	\$4.35
A65364-5010	Blue	4.85	4.35
A65364-8000	Brown	4.85	4.35
A65364-7360	Kelly Green	4.85	4.35
A65364-4510	Orange	4.85	4.35
A65364-3060	Pink	4.85	4.35
A65364-6000	Purple	4.85	4.35
A65364-3010	Red	4.85	4.35
A65364-1020	White	4.85	4.35
A65364-4010	Yellow	4.85	4.35



Creativity Street® Pom Poms Classroom Pack

Package of 300 assorted colors ranging in size from 1/2" to 1-1/2".

NUMBER	EACH	12/EA
A60950-0000	\$10.51	\$9.46



Creativity Street® Craft Pack

Contains several popular craft items in a single package: 30 wiggle eyes, 45 pom poms, 50 stems, and 6 glitter pom poms.

NUMBER	EACH	6/EA
A60920-0000	\$9.96	\$8.98



Creativity Street® Rainbow and Glitter Poms

Add color and sparkle to your craft projects with these rainbow and glitter pom poms. They're great for making animals, jewelry, collages, and more. Assorted colors.

NUMBER	DESCRIPTION	PKG OF	EACH	6/EA
A61750-1005	Glitter 1/2"	80	\$5.33	\$4.79
A61750-1002	Glitter 1"	40	7.81	7.03
A60950-1001	Rainbow 1"	100	4.75	4.29



Creativity Street® Acrylic Gems

Sparkling acrylic gemstones in a 1 lb assortment of sizes, shapes, and colors. Jewels have metal backs and are ready to be added to any project.

NUMBER	EACH	3/EA
A60722-0001	\$20.49	\$18.53



Creativity Street® Rhinestones

Add sparkle and pizzazz to your art and craft projects with these dazzling rhinestones. Assorted colors and sizes. 375 pieces.

NUMBER	EACH	6/EA
A61762-1001	\$17.18	\$15.96



Creativity Street® Sequins & Spangles

Package of sequins in assorted shapes and brilliant colors. For stitching, decoration, and collage.

NUMBER	SIZE	EACH	6/EA
A60718-1004	4 oz	\$8.12	\$7.30
A60718-1002	9 oz	19.39	17.61
A60718-1001	1 lb	30.50	27.44



Creativity Street® Cupped Sequins

8 mm multicolored cupped sequins. 1 oz package.

NUMBER	EACH	12/EA
A60717-1003	\$3.33	\$2.99

Sizes are approximate

3 mm = 1/8"	28 mm = 1-1/8"
6 mm = 1/4"	30 mm = 1-3/16"
15 mm = 5/8"	35 mm = 1-3/8"
	40 mm = 1-9/16"



Creativity Street® Colored Wiggle Eyes

Flat back for gluing. Assorted packages contain Black, Yellow, Blue, Pink, and Green.

Round Packs

NUMBER	DESCRIPTION	SIZE	EACH	12/EA
A60938-1900	100 Asst.	7, 10, 12, 15 mm	\$4.85	\$4.39
A60938-2100	100 Black	7, 10, 12, 15 mm	4.52	4.07

Round Peel-and-Stick Packs — No glue needed. Sizes 7, 10, 12, and 15 mm.

NUMBER	DESCRIPTION	EACH	12/EA
A60938-1003	Pkg of 100 Assorted	\$5.71	\$5.14
A60938-2102	Pkg of 100 Black	5.61	5.09



Creativity Street® 3-D Wiggle Eyes

3-D effects take your creative creations to a whole new dimension. Bright and colorful, they come in a package of 64 peel-and-stick eyes in assorted sizes and colors.

NUMBER	EACH	12/EA
A60938-2003	\$2.80	\$2.52



Creativity Street® Wiggle Eyes 500-pc Pack

This great multipack features 125 pieces each of black, multi, painted, and bright colors in assorted sizes: 10 mm, 12 mm, 15 mm, and 20 mm.

NUMBER	EACH	12/EA
A61461-0500	\$21.25	\$19.50



Creativity Street® Painted Wiggle Eyes

100 round wiggle eyes, each painted with an eyelid and eyelashes. Assorted colors and sizes: 7 mm, 10 mm, 12 mm, and 15 mm.

NUMBER	EACH	12/EA
A60938-1002	\$6.67	\$5.99



Creativity Street® Large Wiggle Eyes

Each package includes 40 each of 28 mm and 30 mm, 10 each of 35 mm and 40 mm.

NUMBER	DESCRIPTION	EACH	12/EA
A60938-1009	Pkg of 100 Assorted	\$26.79	\$24.29
A60938-2101	Pkg of 100 Black	25.79	23.43



Creativity Street® Wiggle Eyes Stack Pack

Five-tier stack pack contains and stores 560 of the most popular round and oval black wiggle eyes in assorted sizes: 5 mm, 7 mm, 10 mm, 15 mm, and 20 mm.

NUMBER	EACH	12/EA
A61766-1560	\$12.60	\$11.33

Acrylic Pom Pons

Fine-quality 100% acrylic puffy poms are extra soft and fun to work with. Bags of 100 in your choice of two sizes.

COLOR	1/2"	1"
Black	A60911-2050	A60911-2010
Canary	A60911-4261	A60911-4361
Royal Blue	A60911-5190	A60911-5290
Kelly Green	A60911-7360	A60911-7460
Light Pink	A60911-3490	A60911-3590
Orange	A60911-4550	A60911-4500
Purple	A60911-5650	A60911-5620
Scarlet	A60911-3080	A60911-3180
Tan	A60911-8250	A60911-8231
White	A60911-1050	A60911-1001
	EACH 12/EA	EACH 12/EA
	\$2.03 \$1.83	\$3.38 \$3.05

100-Pack Assortment — 100 poms in six sizes, ranging from 1/4" to 2". Basic colors.

NUMBER	EACH	12/EA
A60950-1009	\$8.80	\$7.95

Pound of Poms — Approximately 1,200 pieces. Assorted colors and sizes.

NUMBER	EACH	12/EA
A60950-1006	\$25.96	\$23.37

NEW! QUICK QUOTE.
Create a quote on demand at DickBlick.com



Hygloss™ Mosaic Squares

These 1" paper squares are great for collage and mosaic craft projects. Packages contain 10 colors.

NUMBER	PIECES	EACH	12/EA
A01362-1010	1000 pieces	\$7.30	\$6.58
A01362-1025	2500 pieces	6.27	5.64

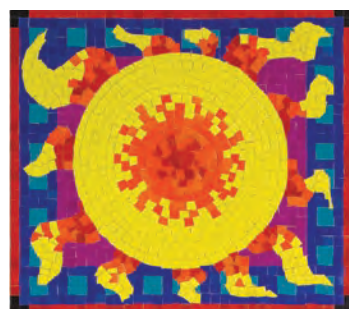

Assorted



Earth Tones

Roylco™ Mosaic Paper Squares

Create endless designs and patterns with colorful, heavy paper mosaic squares. Great for making wall hangings, masks, picture frames, boxes, and more. Assortments contain 10,000 3/8" squares with a different color on each side.

NUMBER	DESCRIPTION	EACH	6/EA
A60974-1001	Assorted	\$12.99	\$11.72
A60974-1003	Earth Tones	12.42	11.21



Roylco™ Spectrum Mosaics

A fun way to introduce kids to color theory, develop math and motor skills, encourage creativity, and more. The package includes 4,000 cardstock squares in 14 bright colors, plus four reproducible grids and a guide with project ideas. Squares measure 3/4".

NUMBER	EACH	6/EA
A65309-4000	\$18.30	\$16.45



Roylco™ Fabric Strips

Weave, braid, and collage! Package contains 72 strips, each 35" long. Colors and patterns vary.

NUMBER	EACH	6/EA
A03160-1072	\$14.32	\$12.88



Ribbon Assortments

These economical assortments contain a variety of colors, designs, and widths — great for embellishing stationery, scrapbook pages, tags, and cards, or for jewelry making and collage. Colors and styles may vary.

NUMBER	DESCRIPTION	EACH	12/EA
A62100-1040	40 yds	\$4.36	\$3.95

Did you know we have hundreds of lesson plans designed to meet the National Standards for Visual Arts Education? See them all at DickBlick.com/lesson-plans.



Hygloss™ Collage Trays

Foam and pulp trays make great backgrounds for artwork. Also use for handing out project supplies; they're strong enough to hold lots of craft materials. Packages of 25.

NUMBER	DESCRIPTION	EACH	6/EA
A61726-1020	Pulp Trays	\$25.35	\$22.81
A61726-1010	Foam Trays	13.96	12.56



Hygloss™ Ultimate Collage Pak

Contains an assortment of papers — enough for a whole classroom to make collages. Includes: Bright Sheets, tissue, Bright Sheet hearts, foil, doilies, medallions, cellophane, Wet'n Stick, construction paper, and die-cut shapes.

NUMBER	EACH	6/EA
A60951-1009	\$28.92	\$26.03



Elmer's™ Glitter Glue

Make your projects unique with a bold, glittery pop of color! Great for crafts and school projects, Elmer's Glitter Glue can be used to decorate, write, draw, and bond multiple materials. It goes on smoothly, washes easily from hands and clothing, and is 100% safe and non-toxic. 6 oz (177 ml) bottles.

NUMBER	COLOR	EACH	12/EA
A65304-2026	Black	\$3.93	\$3.53
A65304-5016	Blue	3.93	3.53
A65304-9016	Gold	3.93	3.53
A65304-7016	Green	3.93	3.53
A65304-4516	Orange	3.93	3.53
A65304-3066	Pink	3.93	3.53
A65304-6006	Purple	3.93	3.53
A65304-3016	Red	3.93	3.53
A65304-9336	Silver	3.93	3.53
A65304-4016	Yellow	3.93	3.53



Crayola™ Washable Glitter Glue

Add some shimmer to your projects and lessons. Acid-free and non-toxic, the washable glue squeezes out easily and dries in as little as 30 minutes. A special cap offers better control.

NUMBER	DESCRIPTION	SET OF	EACH	12/EA
A23838-0059	Bold Blazes	5	\$4.39	\$3.95
A23838-0099	Fiery Flecks	9	7.38	6.63

Classpack — This economical 20-piece set includes four easy-to-squeeze 4 oz bottles each of Red, Blue, Green, Gold, and Silver Washable Glitter Glue.

NUMBER	SET OF	EACH	6/EA
A23838-0209	20	\$68.31	\$61.48



Crayola™ Mini Washable Glitter Glue Set

Small size, BIG color! This glitter glue set contains 16 whimsical, bright, bold colors in a convenient size for smaller hands. Ideal for enhancing school or home projects, the glue is washable and non-toxic.

NUMBER	EACH	12/EA
A23838-0169	\$7.84	\$7.05



Creativity Street™ Glitter Glue

All the pizzazz and sparkle without all the mess. Squeezable bottles have a fine tip to dispense with precision. Tips can be cut for more flow. Accent artwork and embellish craft projects. Bottles are resealable with attached caps. Perfect for the classroom. 4 oz (120 ml) bottles.

NUMBER	COLOR	EACH	12/EA
A23864-4864	Blue	\$3.06	\$2.75
A23864-4034	Gold	3.06	2.75
A23864-7034	Green	3.06	2.75
A23864-1014	Multi-Color	3.06	2.75
A23864-4514	Orange	3.06	2.75
A23864-5634	Purple	3.06	2.75
A23864-2984	Red	3.06	2.75
A23864-2414	Silver	3.06	2.75

Assorted Pack of 8 — Includes one 4 oz bottle each of the colors above.

NUMBER	EACH	6/EA
A23864-1089	\$21.09	\$18.98



Creativity Street™ Glitter Glue Pen Class Pack

This bargain class pack holds 72 resealable 10 cc tubes of non-toxic glitter glue. Tubes are easy to squeeze for small or challenged hands. Twelve assorted iridescent and bright colors.

NUMBER	EACH	6/EA
A61737-1072	\$51.99	\$46.81



Art & Hobby Swabs

Specifically designed and developed in strength and length for the 1001 uses in the art and hobby field. Approximately 6" long. Package of 100 swabs with wooden handles.

NUMBER	EACH	10/EA
A04826-1006	\$1.81	\$1.62



Elmer's™ Glow in the Dark Glue

Add some out-of-this-world detail to art and craft projects! Elmer's Glow in the Dark Glue comes in bright, neon colors — perfect for creating luminous slime or making signs pop. Glue is washable and non-toxic. 5 oz bottles.

NUMBER	COLOR	EACH	12/EA
A23945-5014	Blue	\$9.57	\$8.61
A23945-8454	Natural	9.57	8.61
A23945-3064	Pink	9.57	8.61
A23945-4014	Yellow	9.57	8.61
A23945-4514	Orange	9.57	8.61
A23945-6004	Purple	9.57	8.61



Spectra™ Sparkling Glitter

Add sparkle to any project with these brilliant, bold plastic glitter crystals (0.040 size). They're hexagon-shaped and come in convenient, no-mess shaker-top jars. Non-toxic.

COLOR	4 OZ (120 ML)	16 OZ (473 ML)
Black	A61416-2054	A61416-2051
Blue	A61416-4864	A61416-4861
Clear	A61416-1024	A61416-1021
Copper	—	A61416-8111
Gold	A61416-4034	A61416-4031
Green	A61416-7034	A61416-7031
Iridescent	—	A61416-1001
Magenta	A61416-3044	A61416-3041
Multi-Color	A61416-1014	A61416-1011
Orange	A61416-4514	A61416-4511
Pink	—	A61416-3061
Purple	A61416-5634	A61416-5631
Red	A61416-2984	A61416-2981
Silver	A61416-2414	A61416-2411
Sky Blue	A61416-5074	A61416-5071
Turquoise	—	A61416-5121
White	—	A61416-1041

NUMBER	EACH	12/EA	EACH	3/EA
	\$4.11	\$3.70	\$11.46	\$10.31



Set of 6 — Six popular colors in an easy-use custom tray. Includes one 4 oz (120 ml) jar each of Blue, Gold, Green, Multi-Color, Red, and Silver.

NUMBER	EACH	6/EA
A61417-1009	\$29.25	\$26.34

Set of 12 — Includes two 0.75 oz (22 ml) jars each of Blue, Gold, Green, Multi-Color, Red, and Silver.

NUMBER	EACH	6/EA
A61416-0129	\$26.30	\$23.65



Creativity Street® Plastic Masks

Students can create wall displays by decorating these masks with feathers, glitter, gems, and more. They can also be worn, making them great craft projects for Mardi Gras, Halloween, or classroom performances. Choose from six styles.

NUMBER	DESCRIPTION	EACH	12/EA
A61152-1004	Female Face	\$6.94	\$6.25
A61152-1003	Male Face	6.94	6.25
A61152-1005	Mardi Gras	3.83	3.45



Roylco® Multicultural Face Forms

Designed for papier mâché and clay, these easy-release molds are made from clear plastic. Package of 10 includes two each of five ethnically diverse characters, each beautifully realistic. 5-1/2" x 7".

NUMBER	EACH	3/EA
A61131-1010	\$16.59	\$15.03

Creativity Street® Elastic Cord

The economical choice for every crafter's supply box. 25 yd cards.

NUMBER	COLOR	EACH	12/EA
A61594-1025	White	\$8.10	\$7.25
A61594-2025	Black	8.10	7.25

Roylco® Super Hero Masks

Every kid can be a superhero with these masks made of sturdy cardstock. The package of 24 includes four each of six different designs. Activity sheet included. Made in the USA.

NUMBER	EACH	3/EA
A65306-1001	\$9.64	\$8.67

Face Form for Mask Making

Use it as a base over which to apply plastercraft gauze or paper mâché; then remove it. Or, use it as a mold for clay or plaster. Made of sturdy plastic. Inside dimensions measure 7-1/2"H x 5"W (child size). Outside dimensions: 9" x 6-1/2". Reusable.

NUMBER	EACH	10/EA
A60959-0000	\$2.09	\$1.89



Roylco® Shakespeare Masks

Inspired by the plays of William Shakespeare, these masks are made of sturdy cardstock and can be decorated with paint, markers, gems, and more. This set of 24 features 12 styles.

NUMBER	EACH	6/EA
A65312-1001	\$9.26	\$8.33



Creativity Street® Papier Mâché Masks

Ready to paint or decorate with feathers, glitter, buttons, beads, sequins, and more, these masks are a good value for classroom projects.

NUMBER	DESCRIPTION	EACH	12/EA
A61198-1000	Full Mask, 8"H x 5-1/4"W	\$3.28	\$2.74
A61198-1001	Half Mask, 2-3/4"H x 6"W	2.52	2.27



Roylco® Animal Face Forms™

Create wild animal masks and make your own zoo. Each see-through plastic face form is reusable and great for papier mâché or clay. Fill with plaster to create an animal plaque for your wall. Decorate each creation for a one-of-a-kind critter. Package of five forms, one of each animal shown above. Inside width of each form ranges from 6"-7" (child size).

NUMBER	EACH	3/EA
A61129-1001	\$16.59	\$15.03



Creativity Street® Colossal Craft Masks Kit

Economical classroom pack contains 24 lightweight, colorful masks made of WonderFoam. They come in four styles and colors and are ready to decorate. The kit also includes feathers, glitter glue, and sequins, plus a stretchy cord for each mask.

NUMBER	EACH	6/EA
A61739-1009	\$17.61	\$15.85

Creativity Street® Pulp Masks
These expressive masks are made from recycled paper pulp and have a smooth surface that is easy to decorate with paint, markers, crayons, or embellishments. The Crown and Marauder styles have tie straps.

NUMBER	DESCRIPTION	EACH	12/EA
A61761-1002	Butterfly	\$2.53	\$2.25
A61761-1006	Crown	2.53	2.25
A61761-1001	Human Face	2.53	2.25
A61761-1004	V-Shaped	2.53	2.25
A61761-1003	Venice	2.53	2.25
A61761-1005	Marauder	2.53	2.25



Creativity Street® Paperboard Mask Assortment

Made from recycled paper pulp, these masks have a smooth, easy-to-decorate surface that readily accepts paint, markers, crayons, and all sorts of other embellishments. The assortment contains 24 masks — four each of Koala, Cat, Marauder, Half Butterfly, Full Butterfly, and Full Male Face.

NUMBER	EACH	3/EA
A65303-1024	\$39.89	\$35.91



Roylco® Wild Animal Fold-Up Masks

Fun to decorate, easy to fold, and best of all inexpensive. The assortment contains 30 masks, including five each of six different animals — monkey, lion/tiger, hippo, elephant, koala, and frog. Great for extending art into other areas of the curriculum such as science; teacher guide included.

NUMBER	EACH	12/EA
A65307-1001	\$18.47	\$16.63



Roylco® Fold-Up Fun Masks Class Pack

Three-dimensional masks are easy and fun to make. Simply fold in and tape the pleats, then decorate with crayons, markers, paints, tissue paper, feathers, and more. Package of 40. Project guide included.

NUMBER	EACH	6/EA
A61796-1040	\$10.66	\$9.57



Roylco® African Masks

Masks are a popular tradition in many cultures. African masks are worn to celebrate victory, to ward off evil, and for story telling. Incorporate a study of African folk tales along with this class project and have students represent different characters or feelings with each mask. Masks measure 11" x 15" and come in a package of 20. Simply punch out, fold, staple, and decorate.

NUMBER	EACH	6/EA
A61130-1001	\$13.22	\$11.89



Creativity Street® Die Cut Paper Masks

These masks have crisp, die cut edges and are ready to decorate with paint, markers, glitter, gems, feathers, and more. Once they are decorated and allowed to dry, simply add elastic or string (not included) and they are ready to wear. Package of 50.

NUMBER	EACH	12/EA
A03157-1001	\$5.55	\$4.99



Creativity Street® Mardi Gras Paper Masks

Punch-out, disposable paper Mardi Gras Masks in a pack of 24 for low-budget classroom projects. Includes four each of six different designs.

NUMBER	EACH	6/EA
A61793-1024	\$5.24	\$4.70



Roylco® Poseable People Stencil

This stencil pivots at the neck, waist, hips, elbows, wrists, knees, and ankles, so kids can create almost any pose. Made of a lightweight, see-through material that's easy to clean, this 13-1/2" stencil can be traced using pencils or markers. Idea guide included.

NUMBER	EACH	12/EA
A55765-1350	\$12.49	\$11.23



Draw On It Sew It



Glue It Staple It



Paint It Easy to Cut



Water-Repellent — Great for Outdoors!

Smart-Fab® Art and Decoration Fabric Sheets

The Smart-Fab teachers and crafters love in 12" x 18" sheets! Offered in Black, White, and two multicolor assortments.

NUMBER	COLOR	SIZE	PKG OF	EACH	12/EA
A62130-2006	Black	12" x 18"	45	\$13.19	\$11.86
A62130-1026	White	12" x 18"	45	13.19	11.86
A62130-1006	Assorted	12" x 18"	45	13.19	11.86
A62130-1106	Assorted	12" x 18"	270	63.25	56.92
A62130-1023	Assorted	9" x 12"	270	36.15	32.54



A-D Smart-Fab® Art and Decoration Fabric Borders

Borders are pre-stitched and ready to decorate bulletin boards and displays. Each pack includes three 2-1/2"W x 8 ft strips.

NUMBER	COLOR	EACH	12/EA
A03187-1001	A Rainbow	\$26.76	\$24.04
A03187-1002	B Fire	26.76	24.04
A03187-1003	C Forest	26.76	24.04
A03187-1004	D Pastel	26.76	24.04

SMART-FAB®

Smart-Fab® Art and Decoration Fabric Rolls

Smart-Fab is the smart alternative to paper and cloth. Pleasantly cloth-like to the touch, it's an innovative non-woven fabric that's easy to cut, fold, glue, staple, and sew. Use it for indoor/outdoor projects, such as bulletin boards, displays, decorations, costumes, and stage scenery. The 36" x 600 ft rolls ship directly from the manufacturer. FOB Factory. See page 648 for details.

COLOR	48" X 40 FT	36" X 600 FT
Apple Green	AF62500-7174	AF62107-7176
Black	AF62500-2004	AF62107-2006
Blue	AF62500-5014	AF62107-5016
Brown	AF62500-8014	AF62107-8016
Cranberry	AF62500-3314	—
Cream	AF62500-1104	—
Dark Blue	AF62500-5044	AF62107-5046
Dark Pink	AF62500-3324	AF62107-3326
Dark Purple	AF62500-6044	AF62107-6046
Grass Green	AF62500-7244	AF62107-7246
Orange	AF62500-4514	AF62107-4516
Red	AF62500-3014	AF62107-3016
Sky Blue	AF62500-5094	—
White	AF62500-1024	AF62107-1026
Yellow	AF62500-4014	AF62107-4016
	EACH 12/EA	EACH 3/EA
	\$22.71 \$20.44	\$174.15 \$156.73

Smart-Fab® Double-Thick Fabric Rolls

Twice as thick as original Smart-Fab, with an increased opacity that makes it great for backgrounds on bulletin board displays. Handy roll format makes it easy to cut only as much as you need. Rolls are 48" x 24 ft and fit standard paper-roll racks.

NUMBER	COLOR	EACH	12/EA
A61091-2024	Black	\$26.76	\$24.04
A61091-7034	Dark Green	26.76	24.04
A61091-3014	Red	26.76	24.04
A61091-5074	Sky Blue	26.76	24.04
A61091-1024	White	26.76	24.04
A61091-4014	Yellow	26.76	24.04

Creativity Street® WonderFoam® Sheets

Fun and flexible foam sheets that cut easily with scissors. Pieces can be glued or sewn. Water-resistant. 1/16" thick.

Assorted Colors — White, Black, Red, Royal Blue, Purple, Yellow, Kelly Green, Orange, Brown, and Flesh.

NUMBER	DESCRIPTION	EACH	6/EA
A60947-1023	10-Sheet Pack, 9" x 12"	\$7.90	\$7.10
A60947-1000	10-Sheet Pack, 12" x 18"	14.05	12.73

Multicultural Colors — Great for faces and figures. Pack includes three sheets each of Peach, Tan, and Brown, and one sheet of Dark Red.

NUMBER	DESCRIPTION	EACH	6/EA
A60947-1012	10-Sheet Pack, 12" x 18"	\$14.05	\$12.73

Glitter Colors — Add sparkle to any project without a lot of mess. White, Silver, Gold, Orange, Red, Pink, Green, Blue, Purple, and Black.

NUMBER	DESCRIPTION	EACH	6/EA
A60947-1010	10-Sheet Pack, 8-1/4" x 11-3/4"	\$17.89	\$16.10

Creativity Street® WonderFoam® Jumbo Craft Sticks

These lightweight, brightly colored craft sticks are easy to cut and glue. Use them for craft projects, modeling, jewelry, and much more. Sticks measure 6" x 3/4". Pack of 100 in assorted colors.

NUMBER	EACH	6/EA
A65315-1001	\$7.52	\$6.77



WONDERFOAM®

Creativity Street® WonderFoam® Peel & Stick Shapes & Sheets

With a pre-applied adhesive backing, these sheets and shapes are easy and fun for kids to work with. Choose the 720-piece bag of assorted colors, shapes, and sizes or the 20-sheet pack of 9" x 12" foam sheets that can be cut into any shape. Both items in 10 assorted, bright colors.

NUMBER	DESCRIPTION	EACH	12/EA
A61731-1010	Multicolored Shapes, 720 pieces	\$9.67	\$8.71
A61731-1023	Multicolored Sheets, 20 sheets, 9" x 12"	18.51	16.65

Creativity Street® WonderFoam® Mosaic Tiles

Foam squares in assorted colors for creating colorful mosaic designs. Arranging small pieces into a larger design develops manual dexterity and patience. Class Pack contains 2,700 tiles with 12 blank grid cards measuring 5-5/8" x 5-5/8", 4 oz tacky glue, and instruction guide.

NUMBER	DESCRIPTION	EACH	6/EA
A61738-0500	500-piece Bag	\$6.17	\$5.55
A61738-1001	Class Pack	58.99	53.09



Kunin Rainbow Classic Felt Sheets

Craft in a rainbow of hues using this quality felt made with Eco-fi, a 100% polyester fiber made from recycled post-consumer plastic bottles. (Red is 85% Eco-fi and 15% acrylic.) 9" x 12" sheets or single-color packs of 24, 9" x 12" sheets.

NUMBER	COLOR	EACH	12/EA
A65301-5162	Aqua	\$.49	\$.45
A65301-5512	Baby Blue	.70	.63
A65301-4112	Baby Pink	.70	.63
A65301-2912	Black	.70	.63
A65301-6032	Bright Lilac	.49	.45
A65301-8212	Cashmere Tan	.70	.63
A65301-2132	Charcoal	.49	.45
A65301-8112	Cocoa Brown	.70	.63
A65301-3312	Cranapple	.49	.45
A65301-3752	Fuchsia	.49	.45
A65301-9312	Gold	.70	.63
A65301-7362	Kelly Green	.49	.45
A65301-5812	Lagoon	.49	.45
A65301-7512	Minty	.49	.45
A65301-7772	Neon Green	.49	.45
A65301-5322	Ocean Blue	.49	.45
A65301-4612	Orange	.70	.63
A65301-6422	Orchid	.49	.45
A65301-6002	Prickly Purple	.49	.45
A65301-3912	Red	.70	.63
A65301-5912	Royal Blue	.70	.63
A65301-4912	Shocking Pink	.70	.63
A65301-2412	Silver Grey	.70	.63
A65301-2462	Smoke	.49	.45
A65301-5662	Twilight Blue	.49	.45
A65301-8912	Walnut Brown	.49	.45
A65301-1912	White	.70	.63
A65301-4112	Yellow	.70	.63

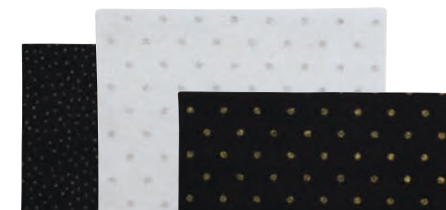

Kunin Coordinates Felt

These 9" x 12" pieces are perfect for Valentine's Day crafts, birthday decorations, and apparel projects. The felt is made with Eco-fi, a polyester fiber made from 100% recycled post-consumer plastic bottles. (Red is 85% Eco-fi and 15% acrylic.)

NUMBER	COLOR	EACH	24/EA
A61267-1003	Black w/ Gold Dots	\$.98	\$.87
A61267-1005	Black w/ Small Metallics	.98	.87
A61267-1007	White w/ Silver Dots	.98	.87

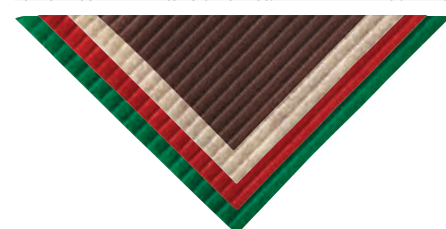

Kunin® Corduroy Felt

This traditional corduroy pattern adds style and texture to home, school, camp, and holiday craft and décor projects. Made with Eco-fi, a 100% polyester fiber made from recycled post-consumer plastic bottles. (Red is 85% Eco-fi and 15% acrylic.) 9" x 12" sheets.

NUMBER	COLOR	EACH	12/EA
A60893-7413	Pirate Green	\$.92	\$.84
A60893-3013	Red	.92	.84
A60893-8923	Sandstone	.92	.84
A60893-8913	Walnut	.92	.84

KUNIN®



Kunin® Premium Felt

This premium crafting felt is thicker than typical felt. It's wonderful for creating flowers and succulents, costumes, décor, and more. This high-quality felt is made with Eco-fi®, a 100% polyester fiber made from recycled post-consumer plastic bottles. (Red is made of 85% Eco-fi and 15% acrylic.) 9" x 12" sheets.

NUMBER	COLOR	EACH	12/EA
A60868-2020	Black	\$1.43	\$1.28
A60868-3100	Candy Pink	1.43	1.28
A60868-8230	Cashmere Tan	1.43	1.28
A60868-2610	Charcoal	1.43	1.28
A60868-9500	Copper Canyon	1.43	1.28
A60868-7360	Kelly Green	1.43	1.28
A60868-5130	Lagoon	1.43	1.28
A60868-4510	Orange	1.43	1.28
A60868-6420	Orchid	1.43	1.28
A60868-5300	Neon Blue	1.43	1.28



Kunin® Presto Peel & Stick Felt

Simply cut out the shapes you desire, peel off the backing sheet, and stick to almost any surface. Made with Eco-fi, a 100% polyester fiber made from recycled post-consumer plastic bottles. (Red is 85% Eco-fi and 15% acrylic.) 9" x 12" sheets.

NUMBER	COLOR	EACH	12/EA
A24296-2023	Black	\$1.67	\$1.50
A24296-8423	Cashmere	1.67	1.50
A24296-2123	Charcoal	1.67	1.50
A24296-8363	Coca Brown	1.67	1.50
A24296-3753	Fuchsia	1.67	1.50
A24296-7363	Kelly Green	1.67	1.50
A24296-5043	Navy Blue	1.67	1.50
A24296-7773	Neon Green	1.67	1.50
A24296-4513	Orange	1.67	1.50
A24296-3013	Red	1.67	1.50
A24296-5053	Royal Blue	1.67	1.50
A24296-2233	Silver Grey	1.67	1.50
A24296-1023	White	1.67	1.50
A24296-4013	Yellow	1.67	1.50



Creativity Street® Felt Sheet Assortment

Economical pack contains 12, 9" x 12" sheets of felt in assorted colors.

NUMBER	EACH	6/EA
A61753-1023	\$8.62	\$7.75



Kunin® Glitter Felt

Festive felt that's perfect for holiday crafts, birthday decorations, and more. Made with Eco-fi, a 100% polyester fiber made from recycled post-consumer plastic bottles. (Red is 85% Eco-fi and 15% acrylic.) 9" x 12" sheets.

NUMBER	COLOR	EACH	12/EA
A60894-2023	Black	\$.90	\$.82
A60894-6133	Fuchsia	.90	.82
A60894-7363	Kelly Green	.90	.82
A60894-3013	Red	.90	.82
A60894-5053	Royal Blue	.90	.82
A60894-1023	White	.90	.82



Grafix® Artist Series Shrink Film

Make instant, durable embellishments with illustrated designs by three popular artists. Decorate, cut out, and heat designs in the oven or with a heat gun — they'll shrink to 20% of their original size. Each pack contains four 8-1/2" x 11" sheets, two preprinted sheets of the same design and two clear sheets for tracing.

NUMBER	DESCRIPTION	EACH	12/EA
A60875-1011	Art Supplies	\$7.03	\$6.33
A60875-1008	Celestial	7.03	6.33
A60875-1010	Eyes	7.03	6.33
A60875-1006	Feathers	7.03	6.33
A60875-1007	Succulents	7.03	6.33

For more Grafix Artist Series Shrink Film visit DickBlick.com.



Grafix® Shrink Film

Fantastic film shrinks to hard, durable plastic embellishments that are 9X thicker and 20–50% smaller. Simply create, cut, and bake. Use in conventional or toaster ovens or with a heat gun. Includes full instructions, tips. 8-1/2" x 11" sheets.

6-Sheet Packs

NUMBER	COLOR	EACH	12/EA
A61412-2020	Black	\$6.72	\$6.05
A61412-1100	Clear	6.72	6.05
A61767-7020	Green	6.72	6.05
A61412-2100	Matte	6.72	6.05
A61767-4510	Orange	6.72	6.05
A61767-6010	Purple	6.72	6.05
A61767-3010	Red	6.72	6.05
A61412-1010	White	6.72	6.05

NUMBER	COLOR	EACH	12/EA
A61767-4010	Yellow	6.72	6.05
A61767-1010	Assorted	6.72	6.05

50-Sheet Packs

NUMBER	COLOR	EACH	12/EA
A61412-2030	Black	\$29.79	\$26.81
A61412-1200	Clear	29.79	26.81
A61412-1030	White	29.79	26.81



Perler® Bead Craft

Kids can make colorful basic shapes and more elaborate designs including dolphins, kittens, flowers, and more. They simply arrange Perler Beads of various colors on a pegboard. Then an adult covers them with ironing paper (sold separately) and fuses the beads together with a household iron. A great activity for children with special needs, individuals with developmental disabilities, and the elderly. For details, visit DickBlick.com.

NUMBER	DESCRIPTION	EACH	6/EA
A60964-1020	24 Small Novelty Shapes	\$20.81	\$18.73
A60964-1010	18 Large Basic Shapes	21.48	19.33
A60964-1050	Ironing Paper	3.40	3.06



Small Novelty Shapes

Grafix® Sanded Shrink Film

Just like the original, except it has a textured surface that's perfect for colored pencils! It's also fun to decorate with permanent markers, die cuts, and rubber stamps. 8-1/2" x 11" sheets.

NUMBER	DESCRIPTION	EACH	12/EA
A61412-1006	6 Sheets	\$6.72	\$6.05
A61412-1150	50 Sheets	29.79	26.81



Captain Creative Magic Nuudles

This packing peanut-like art material is made with cornstarch and dyed with food coloring. Moisten with a damp paper towel or sponge and they stick to each other or to other surfaces. Biodegradable and non-toxic. Bag includes 600 Nuudles approximately 1-1/4"L x 1/2"Dia.

NUMBER	COLOR	EACH	5/EA
A65327-1001	Bold	\$13.22	\$11.89
A65327-1101	Bright	13.22	11.89



Creativity Street® Deluxe Wax Works®

Moldable, bendable, reusable, stickable! Wax Works sticks to itself or paper but won't stick to hands or make a mess. Assortment sets contain 50, 10" sticks (10 each of five colors). Non-toxic, non-flammable. Ages 3+.

NUMBER	DESCRIPTION	EACH	12/EA
A61742-1010	Bright Hues	\$12.71	\$11.44
A61742-1020	Hot Colors	12.71	11.44



Creativity Street® Wax Works® Sticks

These moldable, bendable, reusable sticks are great for art projects of all kinds. The set contains 48 brightly hued strips, each measuring 8"L x 2 mm Dia.

NUMBER	EACH	12/EA
A61742-1048	\$5.79	\$5.21

Helpful for individuals with special needs.



Shapescapes® Sculpture in a Box

Inspired by the works of Joan Miró and Alexander Calder, each Shapescapes set contains a range of pieces in colorful, whimsical shapes for building an infinite variety of vibrantly colored structures. Once complete, they can be displayed as a sculpture, wall hanging, or mobile.

NUMBER	EACH	12/EA
A61090-1001	\$38.57	\$34.71



Roylco® Chipboard Sculptures

Use water to sculpt lifelike creatures! These creative kits contain chipboard designs you simply wet with water, then curve and crease to form wings, tails, and more. When dry, the animals can be painted and displayed in a realistic nature exhibit. Kits include 24 sculptures (up to 9-1/2" x 5-1/2") and an instruction guide.

NUMBER	DESCRIPTION	EACH	6/EA
A03165-1024	Insects	\$13.53	\$12.17

Artstraws®

Creative fun for kids of all ages! Make animals, flowers, figures, mobiles, jewelry, castles, bridges, and dolls. Paper straws are easy to bend, cut, color with markers or watercolors, and they stick with school glue. Use in all art, crafts, design, and childhood development programs. 16-1/2" straws are 4 mm in diameter. Assorted Color pack contains 1,350 pieces. White pack contains 1,800 pieces.

NUMBER	COLOR	EACH	6/EA
A61775-1350	Assorted Colors	\$63.25	\$56.99
A60903-1004	White	57.03	51.32



Mad Mattr® Quantum Packs

These packs contain 10 oz of a super-soft, fluffy modeling compound that's easy to mold and build into any shape you want. It can be mixed with other colors for even more fun. Unique, non-toxic formula is wheat, gluten, and casein free. Ages 3 and up.

NUMBER	COLOR	EACH	6/EA
A76227-5011	Blue	\$14.32	\$12.89
A76227-7011	Green	14.32	12.89
A76227-3061	Pink	14.32	12.89
A76227-7010	Teal	14.32	12.89



Twisteez® Colored Wire

Fine-gauge, pliable wire. Plastic-coated in bright assorted colors. Perfect for mobiles, sculptures, braiding, twisting, and more. Package of 50 wires, each 30" long. 125 total feet.

NUMBER	EACH	6/EA
A33407-1050	\$12.11	\$10.90

Twisteez Bulk Pack — Package of 200 pieces, each 30" long. 500 total feet.

NUMBER	EACH	6/EA
A33407-1009	\$41.35	\$37.22



Faber-Castell® Do Art Sand Painting Kit

Everything you need to create five mixed media, 3-D works of art: five tubes of sand paint, a palette of 12 watercolors with a brush, three blank and two resist design boards, a texture tool, palette knife, loose sand, twist-top containers for mixing custom paint colors, and illustrated instructions. For ages 6 and up.

NUMBER	EACH	6/EA
A60888-1001	\$19.85	\$17.86



Faber-Castell® Creativity for Kids® Gardens

Create your own miniature garden with these all-in-one kits!

Grow N' Glow Terrarium — Includes one 5"H x 3-1/2"W plastic jar with lid, potting mix, seeds, figurines, decorative sand, river stones, and a plant mister, plus translucent and glow-in-the-dark stickers.

NUMBER	EACH	4/EA
A73074-1001	\$16.69	\$15.03

Magic Bean Garden — Includes a planter, colored garden stones, potting mix, paint, paintbrush, and three magic message beans.

NUMBER	EACH	4/EA
A73074-1004	\$16.69	\$15.03



Faber-Castell® Creativity for Kids® Create with Clay Dinosaurs

Art and science come together in this fun STEAM activity. It includes five colors of clay, two molding tools, wiggly eyes, and three plastic dinosaur skeletons, plus dinosaur facts. For more details, visit DickBlick.com.

NUMBER	EACH	6/EA
A64257-1001	\$18.73	\$16.85



Faber-Castell® Dot a Design

Paint and dot your way to colorful works of art. Each design features printed guidelines and dots for ease in pattern placement. The set includes eight acrylic paints, two fine tip dotters, one medium tip dotter, six design sheets, one paintbrush, sticky tac, two frames, sticky foam, and hang tabs for display.

NUMBER	EACH	6/EA
A01372-1001	\$13.97	\$12.57



Faber-Castell® Color and Learn Alphabet Flash Cards

A creative way to develop letter sound relationships, visual recognition, and writing skills! This set includes six Faber-Castell Beeswax Crayons, a sharpener, 26 cards, and a dry-erase tracing mat.

NUMBER	EACH	6/EA
A60885-1001	\$10.99	\$9.91



Faber-Castell® Creativity for Kids® Make Your Own Sock Puppets

Encourage language development and spontaneous creative play! This kit includes fuzzy sock puppets, peel-and-stick felt shapes, self-adhesive fur, six fluffy pom poms, wiggle eyes, and a blunt-end plastic needle.

NUMBER	EACH	6/EA
A76348-1002	\$19.07	\$17.16



Faber-Castell® Paint by Number Museum Series

Recreate famous masterpieces by popular artists in an approachable way. Each kit includes a 6" x 8" canvas, pop-up easel, paintbrush, six acrylic paint colors, and a hang tab to display your artwork.

NUMBER	DESCRIPTION	EACH	6/EA
A64236-1002	Eiffel Tower	\$8.83	\$7.95
A64236-1005	Japanese Footbridge	8.83	7.95
A64236-1003	Starry Night	8.83	7.95
A64236-1006	Sunflowers	8.83	7.95



Faber-Castell® Coloring with Clay Kit

Use clay in a new way. This set features four pre-printed design boards with an animal design that can be colored in with clay. It also includes 12 vibrant sticks (32 g each) of non-drying clay, a silicone tip blending tool, three double-sided clay tools, one wooden roller, a clay play mat, four chipboard easel backs, and instructions.

NUMBER	EACH	6/EA
A60886-1001	\$16.69	\$15.03



Faber-Castell® Creativity for Kids® Paracord Kits

All the supplies you need to create eight paracord wristbands! These kits include eight 7.9 ft lengths of paracord, glue, scissors, buckles, stickers, an acetate piece, and instructions.

NUMBER	DESCRIPTION	EACH	6/EA
A73538-1001	Color Cord Bracelets	\$17.68	\$15.92
A73538-1002	Paracord Wristbands	17.68	15.92



Flycatcher Smart Sketcher® Projector

This compact, portable sketcher and projector encourages creativity and learning. Trace images from the included SD card, which contains 50 pre-loaded Project & Sketch and Project & Learn activity packs. Or trace photos you've taken on a mobile device using an app. Instructions included.

NUMBER	DESCRIPTION	EACH
A61274-1001	Projector	\$63.58
A65357-1001	Jungle Animals	13.77
A65357-1002	On the Farm	13.77
A65357-1003	Space Odyssey	13.77
A65357-1003	Under the Sea	13.77



Melissa & Doug® Stamp Sets

Create colorful cards, scenes, and stories. These themed stamp kits encourage creativity, fine motor skills, hand-eye coordination, and narrative thinking. They include washable ink and stamps with rubber faces and contoured wooden handles. Ages 4 and up.

NUMBER	DESCRIPTION	EACH
A74277-1709	ABC Activity	\$23.72
A74277-1509	Fairy Garden Scene	23.72
A74277-1609	Favorite Things	20.30
A74277-1409	Princess	14.47



Kid Made Modern® Craft Kits

These colorful kits include everything you need to learn printmaking, create masks, and make jewelry. For kit contents, visit DickBlick.com.

NUMBER	DESCRIPTION	EACH
A64254-1001	Jewelry Jam	\$33.99
A64254-1004	Make A Mask	16.79

smART Pixelator™

The Pixelator is a tablet that uses light technology to create an image of your picture or design on its screen. Create a 2-D or 3-D pixelized version of any image! Choose from 50 pre-loaded designs or download a picture from your mobile phone using Bluetooth connectivity.

NUMBER	DESCRIPTION	EACH
A62154-1000	Machine	\$66.13
A62154-1010	Organizer	22.03
A62154-1020	Small Bead Set A	10.99
A62154-1030	Small Bead Set B	10.99
A62154-1080	Small Peg Set A	10.99
A62154-1070	Small Peg Set B	10.99
A62154-1040	Small Sequins Set A	10.99
A62154-1060	Small Sequins Set B	10.99
A62154-1050	Large Sequins Set	16.52



Melissa & Doug® Activity Rugs

These multi-terrain rugs will entertain for countless playtimes to come. The durable, machine-washable rugs have reinforced borders and skid-proof backing that's safe on all floor surfaces. Each 39"L x 36"W rug includes figurines to play with.

NUMBER	DESCRIPTION	EACH
A65386-1004	Barnyard Farm	\$37.33
A65386-1002	City Rescue	37.33
A65386-1003	Construction Zone Work Site	37.33
A65386-1001	Town Road	37.33



Town Road

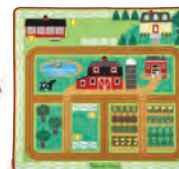

Barnyard Farm



Construction Zone Work Site



City Rescue



Kid Made Modern Arts and Crafts Library

The perfect starting point for beginners, this kit contains over 1,000 popular craft supplies and tools.

NUMBER	EACH
A02049-1002	\$54.99

Kid Made Modern® Studio in a Box Kit

This kit contains high-quality tools for sketching, painting, and coloring, packed in a convenient carrying case. For complete kit contents, visit DickBlick.com.

NUMBER	EACH
A64254-1005	\$50.39



Activa® Sand Expression Boards

Permanent adhesive boards to create your own original paintings. Here's how: transfer your pattern or drawing onto the surface of the art board. Using an art knife, cut through the release paper along all pencil lines. Select your first color, remove all pre-cut areas of release paper for that color, then add sand.

NUMBER	SIZE	EACH	6/EA
A24901-1001	5" x 7"	\$1.41	\$1.29
A24901-1005	11" x 14"	2.39	2.19



Colored Sand

For sand painting, sand art in bottles, terrariums, cactus gardens, etc.

COLOR	2 LB BAGS	25 LB BAGS
Beige	A61006-8142	—
Black	A61006-2002	A61006-2050
Brown	A61006-8002	A61006-8040
Lavender	A61006-6042	A61006-6050
Light Blue	A61006-5012	A61006-5020
Orange	A61006-4502	A61006-4510
Red	A61006-3002	A61006-2980
Royal Blue	A61006-5052	A61006-5060
White	A61006-1002	A61006-1040
Yellow	A61006-4002	A61006-4020
	EACH \$2.83	EACH \$35.83
	12/EA 2.55	6/EA 32.25



Crushed Pebbles

An interesting and brilliantly colorful medium. Trace a design onto a base. Then apply a thin layer of white glue, one color area at a time, to board. Next, shake pebbles onto the glue in the color you desire. 5 lb package.

NUMBER	COLOR	EACH	5/EA
A61005-2005	Black	\$4.10	\$3.68
A61005-5005	Blue	4.10	3.68
A61005-7005	Green	4.10	3.68
A61005-5015	Light Blue	4.10	3.68
A61005-3005	Red	4.10	3.68
A61005-1005	White	4.10	3.68



Bucket O' Shells

Natural and white seashells plucked from the shores of Mexico, the Philippines, and India come in assorted sizes and shapes for application to almost any craft project. Packed in resealable tubs for easy storage and minimal breakage.

NUMBER	DESCRIPTION	EACH	12/EA
A61451-1016	Natural Mix, 16 oz (473 ml)	\$13.22	\$11.89
A61451-1046	White Mix, 16 oz (473 ml)	13.22	11.89



Sand Art Bottles

Clear plastic with natural cork stoppers. Fill with layers of colored sand for intriguing effects. Set of eight traditional plastic bottle styles in sizes ranging from 3"H to 6-3/4"H.

NUMBER	EACH	12/EA
A61010-1008	\$17.92	\$16.13



5-Piece Funnel Set

Perfect for mixing and pouring craft materials, these white plastic funnels are durable and come in a useful range of sizes: 5-3/4"Dia, 4-3/4"Dia, 3-3/4"Dia, 2-3/4"Dia, and 1-3/4"Dia.

NUMBER	EACH	12/EA
A61420-0059	\$11.95	\$10.76



Craft Medley Gemstones

Add sparkle to your DIY craft projects with these acrylic gemstones in various colors, shapes, and sizes. They're an excellent choice for embellishing and personalizing trinket boxes, ornaments, greeting cards, scrapbook pages, frames, and more. 1 oz.

NUMBER	EACH	12/EA
A81698-1001	\$2.62	\$2.35



Hygloss™ Bucket O' Gravel

Add texture and interest to a wide variety of craft projects, including dioramas, picture frames, planter boxes, scrapbook covers. Packaged in 1 lb (454 g) plastic tubs. Set of 6 includes 6 oz tubs of neon colors.

NUMBER	COLOR	SIZE	EACH	6/EA
A61017-7771	Neon Green	1 lb	\$4.36	\$3.92
A61017-4681	Neon Orange	1 lb	4.36	3.92
A61017-3301	Neon Pink	1 lb	4.36	3.92
A61017-6441	Neon Purple	1 lb	4.36	3.92
A61017-4851	Neon Yellow	1 lb	4.36	3.92
A61017-1006	Assorted	6 oz each	11.99	10.80



Hygloss Bucket O' Sequins & Spangles

Featuring an assortment of shapes, colors, and sizes, these fun accents include hearts, butterflies, birds, flowers, stars, and much more. Use them to design one-of-a-kind costumes, collages, greeting cards, and other crafts. Glue or pin onto any surface, including wood. 4 oz.

NUMBER	EACH	12/EA
A80961-1004	\$7.99	\$7.19



Craft Medley Sequins

Add glamor and dazzling effects to almost anything with Craft Medley Sequins. Each sparkly set features a variety of sizes and colors for enhancing craft projects like banners, cards, party hats, and much more.

NUMBER	DESCRIPTION	WEIGHT	EACH	12/EA
A83703-1001	Dazzling Metallics	.85 oz	\$2.99	\$2.69
A83703-1002	Glimmer Glam	.85 oz	2.99	2.69
A83703-1003	Glam Metallics	1 oz	2.99	2.69
A83703-1006	Stars	1.13 oz	2.99	2.69
A83703-1005	Letters & Numbers	1.8 oz	2.99	2.69
A83703-1004	Metallic Letters & Numbers	1.8 oz	2.99	2.69

soap making

For more soap making supplies, visit DickBlick.com.



Life of the Party™ Soap Base

Vegetable-based glycerin soap has humectant moisturizers for clean, soft skin. Suspension Soap allows botanicals to float throughout the bar. Bath Bomb Base yields 12 standard size bath bombs.

NUMBER	DESCRIPTION	WEIGHT	EACH	6/EA
A64217-1002	Clear Glycerin	2 lb	\$10.99	\$9.91
A64217-1012	White Glycerin	2 lb	10.99	9.91
A64217-1022	Shea Butter Glycerin Suspension	2 lb	12.11	10.90
A64217-1008	Bath Bomb	4 lb	22.03	19.83



Life of the Party™ Soap Molds

Create soaps in a variety of shapes and sizes. Soap molds are made from high-grade, safe, FDA approved plastic.

NUMBER	DESCRIPTION	PK OF	EACH	6/EA
A64218-1003	Square	3	\$1.63	\$1.46
A64218-1004	Geometric Shapes	4	2.72	2.44
A64218-1001	Oval and Round	4	2.72	2.44
A64218-1002	Bath Bomb Sphere	6	2.72	2.44



Life of the Party™ Soap Fragrances

Choose from floral, fruity, and herbal cosmetic-grade fragrances to craft your favorite scented soap — or blend fragrances to create a unique scent. 0.5 fl oz bottles.

NUMBER	DESCRIPTION	EACH	6/EA
A64220-1010	Cherry Blossom	\$4.40	\$3.95
A64220-1004	Cucumber Melon	4.40	3.95
A64220-1005	Eucalyptus Mint	4.40	3.95
A64220-1006	Honey Almond	4.40	3.95
A64220-1002	Lavender	4.40	3.95
A64220-1008	Lemon Verbena	4.40	3.95
A64220-1007	Orchid & Coconut	4.40	3.95
A64220-1009	Peach Mango	4.40	3.95
A64220-1003	Pink Lemonade	4.40	3.95
A64220-1001	Vanilla	4.40	3.95



Life of the Party™ Invent-A-Scent

Create fragrances as unique as you. Each pack includes six, 0.27 oz bottles of essential oils, two droppers, and recipe ideas.

NUMBER	DESCRIPTION	EACH	6/EA
A65379-1001	Serenity	\$24.25	\$21.82
A65379-1002	Warm Tropics	24.25	21.82

candle making

For more candle making supplies, visit DickBlick.com.



Country Lane® Candle Making Kits

Become a candle making pro with Country Lane Candle Making Kits. They include everything you need to create up to six handmade candles. For set contents, visit DickBlick.com.

NUMBER	DESCRIPTION	EACH	4/EA
A81520-1001	Pouring Pot Kit	\$28.60	\$25.75
A81520-1002	Soy Candle Making Kit	42.38	38.15



Country Lane® Candle Wicks

Create your own candles with CandleWic Candle Wicks. These wicks have metal wick tabs to hold the wicks in an upright position in the candle container or mold.

NUMBER	DESCRIPTION	SIZE	EACH	12/EA
A81527-1001	Waxed Wicks	9"	\$3.15	\$2.82
A81527-1002	Votive Tabs	3-1/2"	2.09	1.88
A81527-1003	Medium Natural Candle Wicks	9"	3.15	2.82

Country Lane® Premium Paraffin Wax

Specially formulated for votive, pillar, and molded candles, this paraffin wax holds high concentrations of fragrances to fill your home with fresh and relaxing scents. No additives are needed to produce candles with a smooth finish that release easily from molds. Its melting point is 140°F to 150°F, and it's ideal pouring temperature is 175°F to 180°F.

NUMBER	SIZE	EACH	6/EA
A81522-1003	1 lb	\$6.35	\$5.71
A81522-1004	4 lb	21.19	19.07



Neil™ Paper Button Circles

Convenient pre-cut white paper circles save time when making badges or buttons for fund-raising events, school projects, and more. Just draw, stamp, or print your design on a circle, and make a button! Available in two sizes.

NUMBER	DESCRIPTION	EACH	12/EA
A60816-1225	2-1/4"Dia, Pkg of 104	\$4.03	\$3.63
A60816-1003	3"Dia, Pkg of 100	6.05	5.43

button making

Neil™ Metal Button Machine

Durable heavy-duty button machine for large-volume button making. Only requires two steps! Machine comes with enough materials to make 100 buttons, a Creativity Circle Cutter, and a cutting base. Finished buttons are 2-1/4" round. FOB Factory. See page 648 for details.

NUMBER	EACH
AF60814-0000	\$395.00



Neil™ Metal Button Bulk Packs

Convenient bulk packages of button parts for use with the Neil Metal Button Machine. Packages contain Mylar® covers, metal shells, and metal pin backs. Finished buttons are 2-1/4" in diameter.

NUMBER	DESCRIPTION	EACH	3/EA
A60815-0100	Pkg of 100	\$28.22	\$25.40
A60815-0500	Pkg of 500	149.69	134.72
A60815-1000	Pkg of 1000	233.52	210.18



A-D ProMag® Magnets

A Magnetic Sheets — Adhesive or vinyl top side; cuts easily into any shape. Decorate white vinyl sheets with paint or markers for instant artwork.

NUMBER	DESCRIPTION	EACH	12/EA
A61413-1007	Adhesive, 5" x 8"	\$3.07	\$2.76
A61413-1009	Adhesive, 12" x 24"	10.99	9.89
A61413-1010	Paintable, 12" x 24"	10.99	9.89

B Inkjet-Printable Magnetic Sheets — Customize digital photos, images for "instant" picture magnets. Glossy surface works with any inkjet printer. Contains five 8-1/2" x 11" sheets per pack.

NUMBER	EACH	12/EA
A61413-1021	\$14.96	\$13.45

C Magnetic Button Packs — Attach these magnets to any smooth surface with hot glue or Super Glue. Features DYNA-MITE strength for heavier projects. .008 (8 mil) thick.

NUMBER	DESCRIPTION	EACH	12/EA
A61413-1004	1/2"Dia, 10 Buttons	\$1.31	\$1.18
A61413-1006	1/2"Dia, 50 Buttons	6.59	5.93
A61413-1001	3/4"Dia, 6 Buttons	2.19	1.97
A61413-1005	3/4"Dia, 50 Buttons	7.69	6.92

D Adhesive Magnets — Attach your pre-printed business cards or yarn, glitter, and other embellishments to these self-adhesive magnets for business or fun.

NUMBER	DESCRIPTION	EACH	12/EA
A61413-1012	10 Single Card Pack	\$3.29	\$2.96
A61413-1014	3/4", 6 Squares	2.19	1.97
A61413-1013	1", 4 Squares	2.74	2.46
A61413-1011	1/2" x 30" Roll	1.31	1.18
A61413-1016	1/2" x 10 ft Roll	3.29	2.96



Pure White Styrofoam™

A featherlight material that is very popular for countless craft projects. So easy to work with and available in easy-to-cut sheets or pre-cut shapes. Decorate any way you like. Caution: Test paints and glues before assembling project. Paints with rust inhibitor and glues with a high solvent content may melt Styrofoam.

Blocks

NUMBER	SIZE	EACH	12/EA
A60928-1009	1" x 6" x 12"	\$3.08	\$2.77
A60928-1010	1" x 12" x 10"	4.81	4.32
A60928-1011	1" x 4" x 10"	1.99	1.80
A60928-1012	2" x 4" x 12"	3.95	3.56
A60928-1013	1/2" x 12" x 12"	3.55	3.19
A60928-1014	1" x 18" x 12"	7.26	6.53

Smoothfoam™ Crafter's Foam

Paint, pin, glue, cut, or even sand this durable Styrofoam™ alternative! Non-porous expanded polystyrene (EPS) foam is harder and smoother than traditional Styrofoam, making it perfect for a variety of projects. Made in the USA.

Balls

NUMBER	DIAMETER	QTY	EACH	12/EA
A03170-1120	1-1/2"	12	\$4.07	\$3.66
A03170-1003	3"	6	5.09	4.58
A03170-1006	6"	1	6.11	5.50



Half Balls

NUMBER	DIAMETER	EACH	12/EA
A03170-1008	8"	\$9.17	\$8.25
A03170-1012	12"	12.23	10.99

Blocks

NUMBER	SIZE	EACH	12/EA
A03170-1024	2" x 4" x 12"	\$2.38	\$2.15

Sheets

NUMBER	SIZE	EACH	12/EA
A03170-0112	1" x 12" x 28"	\$5.33	\$4.80
A03170-1212	12" x 12" x 5/8"	4.34	3.90

Discs

NUMBER	SIZE	EACH	12/EA
A03170-1061	6" x 1"	\$1.65	\$1.48
A03170-1121	12" x 1"	4.57	4.11



Cork Stoppers

A total of 40 cork stoppers in five assorted sizes are packed in a handy storage container. Natural product is a great medium to use for 3-D art projects. Projects can be built using glue, toothpicks, and a variety of other materials.

NUMBER	EACH	12/EA
A61418-0000	\$7.30	\$6.58



Cork Coasters Class Pack

Quality natural cork coaster rounds can be used for various art projects. Sturdy 3 mm thick. 24 per pack.

NUMBER	DIAMETER	EACH	6/EA
A61497-1004	4"	\$17.97	\$16.15
A61497-1006	6"	24.59	22.10



FloraCraft™ Foam Heads

Unlike Styrofoam™, these expanded polystyrene (EPS) foam heads can be painted and glued without melting the material. The surface can also be sanded. Life-size foam heads are non-toxic and 100% recyclable.

NUMBER	DESCRIPTION	EACH	6/EA
A03166-1057	Faceless	\$5.70	\$5.14
A03166-8611	Female	4.19	3.78
A03166-6910	Male	5.87	5.30



Hot Wire Foam Factory Crafter's Scroll Table

Use it to cut accurate straight lines, perfect curves, or custom shapes in foam. Perfect for modeling buildings, walls, columns, signs, and almost anything that is made with expensive wood cutting scroll tables. The table is 7-1/2 x 11-3/4" with a 6-3/4" hot wire. Cutting depth 7". Made of industrial-strength ABS plastic. Includes four cutting wires.

NUMBER	EACH
A03169-1001	\$44.05

Replacement Cutting Wires — Package of eight.

NUMBER	EACH
A03169-1002	\$21.99

Styrofoam™ Project Bricks

Help children develop their problem-solving and fine motor skills as they design and build castles, igloos, bridges, pyramids, and more using these pre-painted Styrofoam bricks. Contains approximately 280 bricks, each measuring 11/16" x 1-7/16".

NUMBER	EACH	6/EA
A61799-1009	\$29.43	\$26.49



Kemper™ Fetting Knife

Hard 4" long blade with a blunt point is excellent for cutting and shaping Styrofoam™.

NUMBER	DESCRIPTION	EACH	12/EA
A30349-1020	Hard	\$6.15	\$5.50

The Styro Cutter

This simple but very effective tool cuts Styrofoam with a wire which is heated by two D cell batteries (not included). Cuts up to 2" thick pieces.

NUMBER	EACH	12/EA
A60802-0100	\$15.75	\$14.18

Replacement Wires — 3 per pack.

NUMBER	EACH	12/EA
A60802-0000	\$2.91	\$2.62



Sargent Art™ Stretched Burlap Canvas

Paint and decorate this all-purpose brown burlap canvas for mixed media art, holiday décor, and more. It's back-stapled to a 3/4" pine wood frame. The back of the burlap is coated with clear gesso.

NUMBER	SIZE	EACH	10/EA
A65322-1012	8" x 10"	\$13.05	\$11.76
A65322-1005	11" x 14"	17.07	15.38
A65322-1008	16" x 20"	22.10	19.91
A65322-1009	18" x 24"	30.13	27.15



Gold Foil Numbers



Silver Foil Uppercase

Momenta™ Chipboard Alphabet Stickers

These large, adhesive-backed letters or numbers add a colorful punch to your finished project. Each pack includes 40 uppercase letters or numbers, which measure 1-5/8" high and 5/8" to 1-3/8" wide.

NUMBER	DESCRIPTION	COLOR	EACH	12/EA
A03193-1002	Uppercase	Silver Foil	\$7.70	\$6.93
A03193-1003	Numbers	Gold Foil	5.50	4.95

Did you know we have hundreds of lesson plans designed to meet the National Standards for Visual Arts Education? See them all at DickBlick.com/lesson-plans.



Hampton Art™ Wood Plank Surfaces

A great base for hand-lettered signs, home accessories, rustic wedding décor, and more. The planks are light wood for a reclaimed, shabby chic look. Decorate them with paint and other art materials. Hang your finished designs as wall art, use them as display signage, give them as personalized gifts — so many possibilities!

NUMBER	DESCRIPTION	SIZE	EACH	6/EA
A62244-1023	3-D	6" x 6"	\$8.47	\$7.62
A62244-1021	Diagonal	10" x 10"	6.60	5.94
A62244-1024	3-D	12" x 12"	12.10	10.89



Art-C™ Chipboard Alphabet Stencil Set

These two-piece stencils are perfect for mixed media projects. Pop out the die-cut letters to reveal two chipboard shapes. Contains 40 two-piece 5" x 5" stencils (80 pieces total), including duplicates of some letters. The letters are an uppercase serif font.

NUMBER	EACH	12/EA
A03197-1009	\$8.80	\$7.93



Momenta™ Cardstock Alphabet Stickers

Perfect for scrapbooking, party banners, sign making, and other art and craft projects. Packages include 64 cardstock-weight uppercase letter stickers. Sizes range from 4"H x 3/4"W to 4"H x 3-1/3"W.

NUMBER	COLOR	EACH	6/EA
A63998-9330	Black with Silver Foil	\$6.60	\$5.94
A63998-9010	Gold Foil	6.60	5.94
A63998-1001	Watercolor	6.60	5.94
A63998-1002	Wood Print	6.60	5.94

Hampton Art Burlap Banner

Create personalized party accessories, home décor, and displays. The banner features 12 burlap flags attached to an 8 ft hanging string. Decorate them with custom patterns, letters, stencils, paint, and more! The triangular flags are approximately 6-3/4" long.

NUMBER	EACH	6/EA
A03188-1001	\$5.76	\$5.18



Hampton Art™ Mix the Media Framed Boards

These framed wood boards are perfect for displaying photos, memorabilia, and more. Personalize them with paint and embellishments.

NUMBER	SIZE	EACH	6/EA
A80648-1202	6" x 10"	\$12.23	\$10.99
A80648-1209	10" x 10"	14.80	13.32
A80648-1204	12" x 12"	17.36	15.63
A80648-1206	12" x 16"	26.81	24.13



Treasure Chest of Wood

Includes at least 10 lb of a variety of wood shapes for creative uses. It contains dowels in an assortment of sizes, crib slats, 1/2" blocks, petal-like shapes, turnings, and many other shapes. Each box differs and not all shapes are in each box. Not suitable for children younger than age 5.

NUMBER	EACH	3/EA
A60919-0000	\$45.92	\$41.34



Creativity Street® Wood Shapes

There's big fun in this package of wood shapes, including hearts, stars, circles, squares, and ovals. Can be decorated with markers, paint, glitter. Glue them on boxes, frames, and other craft projects to add dimension. Assorted sizes and shapes.

NUMBER	DESCRIPTION	PKG	EACH	6/EA
A60453-1001	Assorted Colors	104	\$8.11	\$7.29
A60453-1000	Natural	1000	27.13	24.42

A

B

A Creativity Street® Craft Sticks

Popsicle-size wooden sticks (3/8" x 4-1/2"). Glue them together to make bird houses, log cabins, fences, forts, rafts, trivets, name tags, wall hangings, and more. Smoothly sanded. Box of 1,000.

NUMBER	EACH	10/EA
A60401-1001	\$11.35	\$10.21

B Creativity Street® Jumbo Craft Sticks

3/4" x 6" wooden sticks. Box of 500.

NUMBER	EACH	10/EA
A60406-0500	\$9.55	\$8.39



Creativity Street® Wooden Dowel Rods

Birchwood dowels are great for a variety of projects. Available in 12" and 36" lengths. Sold in packs of 12.

NUMBER	SIZE	EACH	12/EA
A60448-1412	1/4"Dia x 12"L	\$3.42	\$3.08
A60448-1436	1/4"Dia x 36"L	5.64	5.08
A60448-1212	1/2"Dia x 12"L	9.77	8.79
A60448-1236	1/2"Dia x 36"L	17.09	15.38
A60448-3812	3/8"Dia x 12"L	7.55	6.80
A60448-3836	3/8"Dia x 36"L	9.62	8.65

111 Piece Assortment — Includes 1/8" (34), 3/16" (20), 1/4" (17), 5/16" (15), 3/8" (13), and 1/2" (12). All are 36" long.

NUMBER	EACH	6/EA
A60448-1111	\$52.94	\$47.64



Hygloss™ Wood Blocks

Versatile wooden blocks will accept paint or dye with liquid watercolors, acrylic paint, or markers. Great for making your own ABC blocks. In economical classroom packages.

NUMBER	DESCRIPTION	EACH	6/EA
A60452-1048	48, Assorted Sizes	\$16.53	\$14.87
A60452-1072	72, 3/4" Blocks	16.53	14.87



Creativity Street® Wooden Spring Clothespins

These economical clothespins are made of natural wood with a metal spring. Smoothly finished, they're ready to be embellished with all kinds of craft materials.

Large — 3-3/8" long. Package of 50.

NUMBER	DESCRIPTION	EACH	6/EA
A62144-1338	Natural	\$5.93	\$5.34

Minis — 1" long. Packages of 250.

NUMBER	DESCRIPTION	EACH	6/EA
A62144-1250	Natural	\$15.40	\$13.98
A62144-0250	Assorted Bright Hues	16.15	14.54



Creativity Street® Colored Craft Sticks

Mix and match colored jumbo and regular sizes for fun, festive projects. Six colors: Red, Yellow, Green, Blue, Purple, and Orange. Regular pack: 1,000 pieces each measuring 3/8" x 4-1/2". Jumbo: 500 pieces each measuring 3/4" x 6".

NUMBER	DESCRIPTION	EACH	10/EA
A60406-1500	Jumbo	\$11.20	\$10.08
A60401-1003	Regular	13.59	12.22



Walnut Hollow® Mini Wooden Plaque Assortments

Easy to stain, paint, wood burn, cover with fabric, stamp, or decoupage. Made in the USA from Baltic birch plywood.

72-pc Assortment — 24 each of Circle (4-1/2" Dia), Oval (3-1/2" x 5"), and Rectangle (3" x 5").

NUMBER	EACH	3/EA
A60132-1072	\$86.55	\$77.89

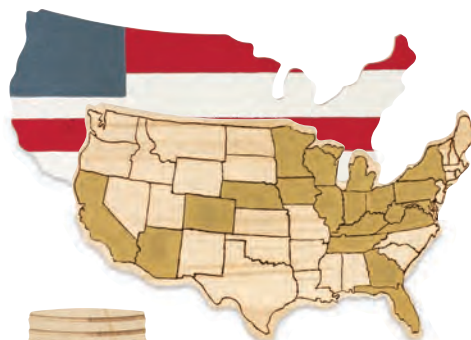

Walnut Hollow Birch Wood Shapes

Walnut Hollow Birch Wood Shapes are made from durable, unfinished Baltic birch that is ready for any finish. Just add paint, stain, or embellishments. Made in the USA.

NUMBER	DESCRIPTION	SIZE	EACH	12/EA
A62296-1002	Mason Jar	5" ? 9" ? 1/4"	\$5.49	\$4.93
A62296-1003	USA Map	14" ? 8-1/2" ? 1/4"	6.59	5.93



MultiCraft Wood Desk Organizers

Customize your desk storage! Choose from a variety of shapes to suit your needs.

NUMBER	DESCRIPTION	EACH	12/EA
A62251-1004	Four Compartment	\$6.63	\$5.97
A62251-1002	Hexagon	6.63	5.97
A62251-1001	Round	6.63	5.97
A62251-1003	Square	6.63	5.97



NEW! Craft Medley Standing Wood Animals

Create personalized room décor with Craft Medley Standing Wood Animals. Each shape has a flat base that allows it to stand up on its own. The unfinished wood surface accepts paint, stain, and glue.

NUMBER	DESCRIPTION	SIZE	EACH	12/EA
A80932-1001	Horse	6-1/2" W x 7-1/2" H	\$5.46	\$4.90
A80932-1002	Unicorn	6-1/2" W x 7" H	5.46	4.90



NEW! Craft Medley Unfinished Wood Toolbox

Create a customized space for craft supplies, jewelry, tools, and more. Unfinished wood is ready to stain, paint, or customize with embellishments.

NUMBER	EACH	12/EA
A80941-1001	\$6.14	\$5.53



Craft Medley Wood Discs

Set includes 60 pieces, each varying in size. Use paint and other embellishments to personalize these natural wood discs.

NUMBER	EACH	12/EA
A80934-1001	\$5.99	\$5.39



Hygloss™ Wooden People Shapes

Assortment of 40 wooden "people" come in five different sizes and shapes to represent the family. Also great for making game pieces. Unfinished. Ready to decorate with paint, markers, and other media. Sizes range from 1-1/4"H to 2-1/2"H.

NUMBER	EACH	6/EA
A28979-1040	\$15.95	\$14.35



NEW! Craft Medley Letter Tiles

Each package contains all 26 letters of the alphabet. Tiles are numbered so that each can be used as a point value, making them great for board-and-tile word games. Each tile measures approximately 3/4" x 3/4".

NUMBER	COLOR	EACH	12/EA
A80911-1001	Classic	\$2.52	\$2.27
A80911-1003	Black and White	2.52	2.27
A80911-1002	Assorted	2.52	2.27



Craft Medley Wood Shapes

Ideal for a variety of DIY craft projects. Personalize the unfinished wooden surface with paint, stain, or embellishments for unique room and wall décor. Each piece measures 8".

NUMBER	DESCRIPTION	EACH	12/EA
A80929-1002	Butterfly	\$5.25	\$4.73
A80929-1005	Mermaid	5.25	4.73
A80929-1001	Star	5.25	4.73
A80929-1006	Unicorn	5.25	4.73
A80929-1003	Wood Plaque with Bracket Border	5.25	4.73
A80929-1003	Rectangle with Cut Corners	5.25	4.73



Creativity Street® Wood Turnings

Wood turning assortments feature many sizes and shapes — perfect for group projects. Natural wood has a smooth surface that's easy to decorate. Great for game pieces! Sizes range from 1"H to 4"H.

NUMBER	WEIGHT	EACH	6/EA
A28978-1005	5 lb	\$37.84	\$34.06



EnviroTex Lite®
Use it to create a hard, high-gloss finish on tabletops, plaques, clocks, figurines, and more. Fully cures in 36 hours. 8 oz kit covers 2–3 sq ft. 16 oz kit covers 4–6 sq ft. 32 oz kit covers 8–16 sq ft. 64 oz kit covers 16–32 sq ft.

NUMBER	SIZE	EACH
A02918-1005	8 oz (237 ml) Kit	\$14.98
A02918-1006	16 oz (473 ml) Kit	24.69
A02918-1007	32 oz (946 ml) Kit	39.73
A02918-1064	64 oz (1.89 Liter) Kit	71.42



Walnut Hollow® Pine Clock Surfaces
Unfinished pine surfaces with a pre-drilled hole. Embellish with numerals, stencils, woodburning, paint, and more. Use with 3/4" clock movements (sold separately).

NUMBER	DESCRIPTION	EACH	6/EA
A62955-1010	11" Round	\$10.36	\$9.32
A62955-1028	6-3/4" Round	5.50	4.95

Walnut Hollow® Pendulum Clock Movements

For 3/4" thick clock surfaces. Small: 7"L; 1-3/4"Dia. Large: 9-5/8"L; 2-3/4"Dia. Both have a 15/16"L shaft. Includes hands. One AA battery required (not included).

NUMBER	DESCRIPTION	EACH	6/EA
A62955-1070	Small, 7" L x 1-3/4" D	\$16.42	\$14.78
A62955-1090	Large, 9-5/8" L x 2-3/4" D	18.62	16.76



A-B Walnut Hollow® Pine Paddles

The perfect blank surface to personalize with favorite designs, phrases, or patterns, or with your sorority or fraternity symbol. Decorate lakeside cabins, bistro-inspired kitchens, and more. Made of solid pine wood, they can be painted, stained, and decorated with craft embellishments. Made in the USA.

NUMBER	DESCRIPTION	SIZE	EACH	12/EA
A28992-1007	A	22-3/4"L x 5"W x 5/8"D	\$7.23	\$6.50
A28992-1015	B	22-1/2"L x 5-1/2"W x 16/25"D	8.27	7.44
A28992-1012		22-3/4"L x 3"W x 1/2"D	8.27	7.44



Walnut Hollow® Pine Shapes

From personalized gifts to wedding and home décor, these shapes are ready for your unique design ideas. The unfinished pine surfaces are great for hand-lettering, painting, woodburning, stenciling, carving, and more. Made in the USA.

NUMBER	DESCRIPTION	SIZE	EACH	12/EA
A28992-1002	Arrow Signboard	16" x 6" x 5/8"	\$9.31	\$8.37
A28992-1004	Hexagon, Small	11-1/4" x 9-3/4" x 2-1/2"	16.57	14.91
A28992-1005	Hexagon, Large	13-3/4" x 12" x 2-1/2"	20.73	18.66
A28992-1010	Bone Signboard	16" x 6" x 5/8"	9.31	8.37
A28992-1007	Paddle	22-3/4" x 5" x 5/8"	7.23	6.50



Ampersand™ Gessobord™ Shadow Boxes

Archival, solid wood Gessobord shadow boxes are primed with premium gesso. 2" deep — great for dioramas and 3-D paintings. Suitable for all media, including oil paint.

NUMBER	SIZE	EACH	12/EA
A14944-0006	6" x 6"	\$18.84	\$16.95
A14944-0008	8" x 8"	20.65	18.58
A14944-0012	12" x 12"	23.35	20.99



Walnut Hollow® Basswood Shapes

Each has a finely sanded, blank surface and is cut in a special way that preserves the bark. Ready for use with woodburning, decoupage, decorative painting, and carving. Perfect for clocks.

NUMBER	SIZE	THICK	EACH	12/EA
A60426-8421	5"-7"	1/2"	\$7.23	\$6.51
A60426-8422	7"-9"	5/8"	9.06	8.15
A60426-8423	9"-11"	3/4"	11.39	10.25



Walnut Hollow® Country Basswood Planks

Made of basswood (the best wood for woodburning) with natural bark borders. Also accepts paint, stain, decoupage, rubber stamping, and more. 0.63" thick. Made in the USA.

NUMBER	SIZE	EACH	12/EA
A33302-8519	Small, 11"H x 7-9"W	\$10.91	\$9.82
A33302-8513	Medium, 13"H x 9-11"W	13.09	11.78
A33302-8516	Large, 16"H x 11-13"W	15.27	13.74
A33302-8523	Extra Large, 23"H x 8-10"W	18.55	16.70



Walnut Hollow® Framed Sign

Each finished, reversible sign features a pine frame and Baltic birch plywood back. They're kiln-dried and finely sanded, so they're ready to be customized. 5/8" profile.

NUMBER	DESCRIPTION	EACH	6/EA
A62299-1001	Small	\$6.60	\$5.94
A62299-1002	Large	8.80	7.93
A62299-1003	Rectangle	10.99	9.91



Walnut Hollow® Creative Woodburning® Kits

Kits feature an easy-to-use woodburning pen with a universal point that's perfect for basic techniques. They also include two basswood surfaces, patterns, transfer paper, and more for a range of creative possibilities. For details, visit DickBlick.com.

Deluxe Kit — This kit features additional points for the woodburning tool, so you can design with greater detail and more technique.

NUMBER	EACH	6/EA
A28996-1001	\$36.30	\$32.67

Kit I — Everything you need to get started.

NUMBER	EACH	6/EA
A28996-1002	\$31.11	\$27.99



Walnut Hollow® Baltic Birch Plaques

These natural, unfinished birch plaques are ready to decorate with paint, stain, glitter, markers, and more. Ideal for collage and decoupage projects. Can also be used as a base for small papier mâché and clay sculptures. 5-1/4" x 7-1/4" x 3/8" thick.

NUMBER	DESCRIPTION	SIZE	EACH	12/EA
A60451-1010	French Corner		\$2.43	\$2.18
A60451-1020	Rectangle		2.43	2.18
A60451-1030	Oval		2.43	2.18



Walnut Hollow® Creative Wood-Burner Value Pen

This woodburner pen is great for basic wood burning techniques. Use the four included points to create a variety of effects. There's a universal point for basic techniques, a cone point for fine lines and dots, a shading point for even shading, and a flow point for curves and fine details.

NUMBER	EACH	6/EA
A03435-1001	\$17.05	\$15.34



Walnut Hollow® Creative Woodburner

This woodburner includes four points for creating precise details, variable textures, and beautiful coloration on wood surfaces. It features stand-alone variable temperature control, a slim, ergonomic handle, and a stand. Nichrome wire points adjust their temperature with a tight tolerance for detail work. For more details, visit DickBlick.com.

NUMBER	EACH	2/EA
A60499-1001	\$91.48	\$82.33



Walnut Hollow® Wooden Boxes

Store keepsakes, recipe cards, and more in a unique box decorated by you! These boxes have a smooth, even wood grain and hinged lids. Also great for woodburning and carving.

NUMBER	DESCRIPTION	SIZE	EACH	6/EA
A60400-1008	Recipe Box	5.83" x 3.98" x 3.94"	\$15.46	\$13.92
A60400-1004	Roomy Box	8.21" x 3.33" x 5.44"	16.51	14.86

Walnut Hollow® Clock Movements

Quality quartz movement. Includes minute, hour, and second hands. The thickness of your clock face should correspond to the thicknesses listed below. One AA battery required (not included).

NUMBER	DESCRIPTION	EACH	6/EA
A62955-1022	3/4", w/Hands & Numbers	\$10.97	\$9.88



Walnut Hollow® Basswood Plaques

Carve a custom welcome sign, stencil a favorite quote, paint a landscape, woodburn a design — the options are endless with Basswood Plaques.

NUMBER	DESCRIPTION	SIZE	EACH	12/EA
A28988-1012	Rectangle	9" x 12"	\$10.99	\$9.91
A28988-1010	Oval	8" x 10"	9.91	8.92

Elmer's® Carpenter's Wood Glue

Grabs fast but allows for repositioning, and will not gum up from heat when sanded or sawed. Penetrates wood deeply for a strong bond. Can be painted and stained.

NUMBER	SIZE	EACH	12/EA
A23893-1004	4 oz (120 ml)	\$3.27	\$2.94



Wall Lenk™ Creative 5-in-1 Tool Kit

Includes hot tool plus nine assorted tips and points needed for woodburning, soldering, leather crafting, stenciling, and Styrofoam cutting. Also includes 5 oz roll of 50/50 resin core solder. Sturdy plastic case.

NUMBER	EACH	6/EA
A60603-1009	\$47.95	\$43.15



HEALTH & SAFETY ICONS: ●=CL / ■=Prop 65 / ▼=CL & Prop 65
See page 644 for more information.

WARNING! Products marked with a Prop 65 symbol (■ or ▼) can expose you to chemicals, including cadmium, which are known to the State of California to cause cancer and birth defects or other reproductive harm. For more information, visit P65Warnings.ca.gov.



Momenta® LED Lighted Papier Mâché Shapes

Make your own colorful, light-up masterpiece. These shapes are ready to paint and decorate with your favorite art supplies. Shapes feature color-changing LED lights and an on/off switch. Two AA batteries required (not included).

NUMBER	DESCRIPTION	EACH	10/EA
A01339-1012	Unicorn	\$15.25	\$13.72
A01339-1022	Rainbow	15.25	13.72
A01339-1032	Dinosaur	15.25	13.72
A01339-1042	Race Car	15.25	13.72



Papier Mâché Mini Boxes

Decorate these little boxes any number of ways! 1-1/2" deep, they're the perfect size for holding jewelry or small gifts.

NUMBER	DESCRIPTION	EACH	12/EA
A60001-8331	Heart, 3-1/4" x 3-1/4"	\$1.19	\$.88
A60001-8341	Round, 3" x 3"	1.19	.88
A60001-8351	Oval, 3-1/2" x 2-1/2"	1.19	.88
A60001-8361	Hexagon, 2-7/8" x 2-7/8"	1.19	.88
A60001-8371	Square, 2-7/8" x 2-7/8"	1.19	.88

Mini Box Class Pack — 24 assorted boxes.

NUMBER	EACH	6/EA
A62101-1002	\$39.79	\$35.81



Creativity Street® Papier Mâché Decorating Kit

All the craft essentials you need to get creative in the classroom or in a large group! This kit includes 24 papier mâché heart, hexagon, and oval boxes, plus glitter, pom poms, sequins, spangles, acrylic gemstones, tacky glue, and glitter glue pens.

NUMBER	EACH	6/EA
A61735-1009	\$74.99	\$39.79 \$35.81



Decorate-A-Frame Kit

Attach a favorite photo and decorate with paint, markers, buttons, mosaics, colored paper, felt, yarn foam, glitter, and more. Includes 25, 5" x 7" pieces of cardboard and 25 easels.

NUMBER	EACH	6/EA
A18935-0000	\$11.40	\$10.25



Papier Mâché Box Sets

Design your own papier mâché box for that special gift! Four different sets of three to choose from: Oval, Heart, Round, and Hexagon. Sizes are approximate.

NUMBER	DESCRIPTION	EACH	12/EA
A60013-8481	Oval, 7-1/2", 8-1/2", 9-1/2"	\$12.12	\$10.90
A60013-8482	Heart, 8", 8-3/4", 9-3/4"	12.12	10.90
A60013-8483	Round, 7-1/2", 8-3/4", 10"	12.12	10.90
A60013-8484	Hexagon, 6-3/4", 7-1/2", 8-1/2"	12.12	10.90



Creativity Street® Papier Mâché Frames Class Pack

Ready to decorate with paints, markers, crayons, and craft materials, these fun papier mâché frames are great for school or team projects. Each class pack contains 24 assorted styles. For details, visit DickBlick.com.

NUMBER	EACH	6/EA
A62101-1001	\$39.79	\$35.81



Cricut® Explore Air 2

This smart cutting machine cuts and writes up to two times faster than previous models and helps you make projects from over 100 different materials, including vellum, paper, cardstock, fabric, leather, and more. Create on your computer, tablet, or smartphone using the Cricut design app, upload image files, or use a pre-made design from Cricut's vast project library.

NUMBER	COLOR	EACH
A33795-1002	Mint	\$262.49



Basic Trimmer Set

Cricut® Tools

These tools are an invaluable complement to your Cricut cutting machine. They'll make the artistic process easier and more enjoyable — especially small, tedious detail cuts.

NUMBER	DESCRIPTION	EACH	6/EA
A63318-1009	Basic Trimmer Set	\$55.10	\$49.25
A63318-1001	XL Scraper	11.59	10.40
A63318-1002	Weeding Kit	27.55	24.60
A63318-1003	Scoring Stylus	10.30	9.25



Cricut® Maker

The ultimate smart cutting machine. The Maker has a Knife Blade for thick materials and an advanced Rotary Blade that slices through virtually any fabric. Even the most difficult patterns are a breeze to cut out. Included sewing pattern library contains hundreds of patterns to choose from.

NUMBER	EACH
A33761-2050	\$423.00



Cricut® Pen Sets

Cricut Pen Sets are designed and optimized to work with Cricut cutting machines. Now you can use your Cricut machine to cut a card and then write a greeting exactly where you want — all in one step.

NUMBER	DESCRIPTION	EACH	6/EA
A01366-1019	Metallic Medium Point	\$14.32	\$12.85
A01366-2029	Multi Color set Black	16.55	14.90



A F

A-F Cricut® Vinyl

Customize without commitment. Create easily removable decals, labels, signs, and more. Use with all Cricut cutting machines. Each roll measures 12"W x 48"L.

NUMBER	COLOR	EACH	6/EA
AG0889-1018	Stencil Material	\$8.80	\$7.93
AG0889-1008	Transfer Tape	8.80	7.93
AG0889-2028	Black	8.80	7.93
AG0889-7918	A Bright Green	8.80	7.93
AG0889-8048	Coffee	8.80	7.93
AG0889-3758	B Fuchsia	8.80	7.93
AG0889-9028	C Gold	8.80	7.93
AG0889-5808	Midnight	8.80	7.93
AG0889-9328	D Silver	8.80	7.93
AG0889-5118	Turquoise	8.80	7.93
AG0889-5428	E Vivid Blue	8.80	7.93
AG0889-1028	White	8.80	7.93
AG0889-3708	F Wine	8.80	7.93



Heidi Swapp™ Minc™ Accessories

These tools and accessories are designed for use with Heidi Swapp Minc Foil Applicators. Use the Toner Mist and Toner Pen to create patterns, phrases, and splatter effects with reactive foil. The Rotary Cutter helps you cut in any direction, and the transfer folders help adhere foil to your project smoothly.

NUMBER	DESCRIPTION	EACH	6/EA
A64288-1002	Rotary Cutter	\$29.92	\$26.93
A64288-1001	Toner Ink Pen	5.60	5.05
A64288-1003	Toner Mist	8.25	7.43
A64288-1004	Transfer Folders, Pkg of 2	6.66	5.99



Heidi Swapp™ Minc™ Foil Applicator

Easily enhance your paper craft projects with shining foil. This heated system adheres foil to toner ink on paper surfaces. The machine has six heat settings, four rollers, and a motor that can move your project forward and backward. They come with a transfer folder, heat-reactive foil, and starter art.

NUMBER	SIZE	EACH
A80906-1006	6"	\$88.18
A80906-1012	12"	165.35

Heidi Swapp™ Minc™ Glitter Sheets

Add glittering foil accents to cards, scrapbooks, planners, and more with these heat-reactive foil sheets. Each package includes four 6" x 8" sheets. Ideal for use with the Heidi Swapp Minc Foil Applicator.

NUMBER	COLOR	EACH	6/EA
A64289-9011	Gold	\$10.99	\$9.91
A64289-3060	Pink	10.99	9.91
A64289-9111	Rose Gold	10.99	9.91
A64289-9331	Silver	10.99	9.91

Heidi Swapp™ Minc™ Reactive Foil

Create unique textural effects on cards and other paper crafts. Layer the foil within a carrier sheet on top of your toner ink design. Then, apply heat — the foil will adhere to the ink, turning your design into a shining work of art. For use with the Heidi Swapp Minc Foil Applicator on heat setting three.

NUMBER	COLOR	SIZE	EACH	6/EA
A64287-2021	Black	12" x 10"	\$10.99	\$9.91
A64287-5011	Blue	12" x 10"	10.99	9.91
A64287-1191	Champagne	12" x 10"	10.99	9.91
A64287-7011	Green	12" x 10"	10.99	9.91
A64287-9011	Gold	12" x 10"	10.99	9.91
A64287-4071	Gold Stars	12" x 6"	10.99	9.91
A64287-1031	Holographic	12" x 5"	10.99	9.91
A64287-3291	Hot Pink	12" x 10"	10.99	9.91
A64287-1061	Iridescent	12" x 5"	10.99	9.91
A64287-1011	Leopard	12" x 6"	10.99	9.91
A64287-3061	Light Pink	12" x 10"	10.99	9.91
A64287-7511	Mint	12" x 10"	10.99	9.91
A64287-3641	Pink and Gold	12" x 5"	10.99	9.91
Ombre				
A64287-3041	Pink Rainbow	12" x 6"	10.99	9.91
A64287-1001	Rainbow	12" x 6"	10.99	9.91
A64287-3011	Red	12" x 10"	10.99	9.91
A64287-3631	Rose Gold	12" x 10"	10.99	9.91
A64287-9331	Silver	12" x 10"	10.99	9.91
A64287-9341	Silver Square	12" x 6"	10.99	9.91
A64287-2161	Steal and Silver	12" x 5"	10.99	9.91
Ombre				
A64287-5081	Teal	12" x 10"	10.99	9.91
A64287-1021	White	12" x 5"	10.99	9.91



Djeco Quilling Kits

Make colorful, spiraling strips of paper. Simply create paper shapes and glue them in place — each kit contains everything you need to get started. For set contents, visit dickblick.com.

NUMBER	DESCRIPTION	EACH	6/EA
A61948-1001	Spiral Seasons	\$27.97	



Bubbles

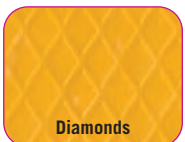

Diamonds



Waves



Straight

Marvy® Uchida Corru-Gator™ Paper Crimpers

Excellent tools for children's crafts and for rubber stamping projects. Great on foil, bond, tissue, and other materials. Made of high-impact plastic.

NUMBER	DESCRIPTION	EACH	12/EA
A62951-0000	Straight	\$15.99	\$14.40
A62951-1030	Bubbles	15.99	14.40
A62951-1020	Diamonds	15.99	14.40
A62951-1010	Waves	15.99	14.40



Uncoated Paper Plates

Because they don't have the moisture-blockers found on standard paper plates, paint, glue, wiggle eyes, and other embellishments adhere with no problem. 9"Dia. Package of 250.

NUMBER	EACH	6/EA
A10493-1029	\$14.08	\$12.67



Hygloss™ Chain Strips

These pre-cut strips are easy to staple, glue, or tape together for party decorations, banners, and woven designs. 1"W x 8"L.

NUMBER	DESCRIPTION	PKG	EACH	12/EA
A09918-1096	Embossed Metallic	96	\$4.23	\$3.80
A09918-1100	Holographic	100	4.23	3.80



Fiskars® Lever Punches

Great for classrooms and playrooms, Fiskars Lever Punches help kids create fun shapes for art projects, scrapbooks, school notebooks, and more. Layer the cutouts for dimensional effects. A confetti catcher keeps work areas clean. Lifetime limited warranty.

Small 5/8" Punches

NUMBER	DESCRIPTION	EACH	6/EA
A57613-1080	Small Circle	\$6.19	\$5.57
A57613-1030	Circle	18.45	16.62



Fiskars® Hand Punches

Durable enough to cleanly punch through virtually any crafting material, even thin leather and metal! Extended softgrip handles make them extra comfortable. Built-in confetti catcher holds punched shapes for future use.

NUMBER	DESCRIPTION	SIZE	EACH	12/EA
A58923-1001	Circle	1/16"	\$9.63	\$8.67
A58923-1011	Heart	1/4"	9.63	8.67
A58923-1007	Rectangle	1/4"	9.63	8.67
A58923-1004	Star	1/4"	9.63	8.67



NEW! QUICK QUOTE.
Create a quote on demand at DickBlick.com

HEALTH & SAFETY ICONS: ●=CL / ■=Prop 65 / ▼=CL & Prop 65
See page 644 for more information.



Jacquard® Marbling Starter Kit

Create colorful, funky swirl patterns on paper, fabric, and more. This kit features marbling paints, mediums, and size to get you started. Instructions also included. For full contents, visit DickBlick.com.

NUMBER	EACH	6/EA
A01241-1009	\$19.47	\$17.52



Jacquard® Marbling Class Pack

Enough supplies for 30 professional-quality projects, including nine bottles of marbling color, alum, carrageenan, synthetic gall, cotton fabric, droppers, and easy-to-follow instructions. Also works great for paper marbling. For full contents, visit DickBlick.com.

NUMBER	EACH	6/EA
A01232-1009	\$89.64	\$80.66



Aitoh™ Boku-Undo Suminagashi Marbling Kit

A simple method for creating beautiful marbled paper or fabric. The kit contains Red, Yellow, Orange, Blue, Green, and Black marbling inks, paper dots, and full instructions. Dyes are waterbased and non-toxic. Perfect for ages 6 through adult.

NUMBER	EACH	12/EA
A01309-1009	\$21.30	\$19.17

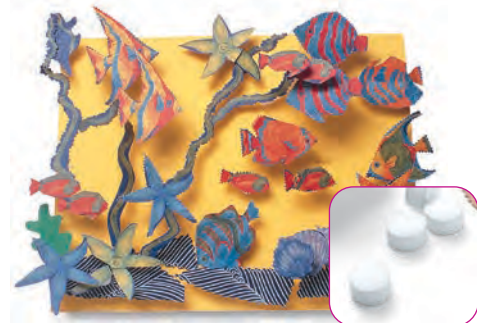

Scratch Art® 3D-O's®

3D-O's are foam circles with pressure-sensitive adhesive on both sides to help you create pictures, posters, and displays that really stand out! Each package contains die-cut circles that are 1/2" in diameter and 1/4" thick.

NUMBER	DESCRIPTION	EACH	6/EA
A14904-0009	Pkg of 100	\$4.44	\$3.99
A14904-1003	Pkg of 400	17.33	15.59



Hygloss™ Mini Bright Books

Mini multi-use blank paperback books feature smooth, brightly colored covers and 12 pages of bond paper inside for creative writing, journaling, list making, and more. Covers and pages accept a wide variety of media. Pages measure 4-1/4" x 5-1/2". Pack of 20.

NUMBER	EACH	6/EA
A12667-1005	\$14.32	\$12.89

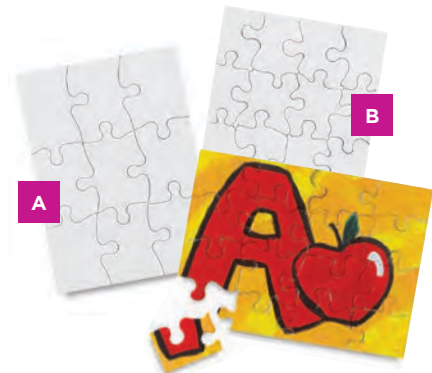

A-B Create-A-Puzzle Kits

Create-A-Puzzle is an unprinted, pre-cut jigsaw puzzle. The blank, white, heavy cardboard surface can be painted with almost anything from tempera paint to felt tip markers. Stays together until you separate it for the first time. Puzzles are 4" x 5-1/2".

A Large-Piece Puzzles — Pack of 12 puzzles with large pieces for kids ages 7 and younger. Nine pieces per puzzle.

B Small-Piece Puzzles — Pack of 12 puzzles with small pieces for those ages 7 and older. Sixteen pieces per puzzle.

NUMBER	EACH	10/EA
A60970-1012	\$7.85	\$7.07
A60970-1112	\$7.85	\$7.07



Nature Print® Paper Sun Printing Kit

Make fascinating white-on-blue prints from natural or manmade materials. Just place flat objects (leaves, flowers, insects, lace, jewelry, and more) on the sun-sensitive paper, expose to the sun, and create photo-montage images. No inks, presses, photo equipment, darkroom, or chemicals needed. Prints develop in tap water in seconds. Instructions included. Non-toxic. Pack of 30, 5" x 7" sheets.

NUMBER	EACH	6/EA	12/EA
A11216-1001	\$10.99	\$9.91	\$9.40

NUMBER	EACH	6/EA	12/EA
A11216-1000	\$12.67	\$11.40	\$10.83

For an online project, visit DickBlick.com/project-ideas/gilded-sun-prints.



C-D Roylco® Color Diffusing Paper™

Decorate these paper cutouts with ink, watercolor paint, or waterbased markers, then mist with water to create fantastic effects. Or create wax-resist designs first for an easy batik craft! Kids love seeing the colors mix and diffuse. Includes idea sheet.

NUMBER	SHAPE	PKG OF	EACH	6/EA
A12602-1010	C Leaves	80	\$9.64	\$8.68
A12602-1020	D Sealife	48	9.64	8.68
A12602-1009	Flowers	80	9.64	8.68
A12602-1011	Butterflies	48	9.64	8.68



Roylco® Carp Windssock

Inspire students to learn about Japanese culture by making fun windssocks! They can be decorated using watercolor diffusing techniques or almost any medium. Just add a string and hang for a colorful display. Each pack contains 24, 6" x 10" paper windssocks and an idea sheet.

NUMBER	SIZE	EACH	6/EA
A63220-1001	Pkg of 24	\$12.25	\$11.03

WARNING! Products marked with a Prop 65 symbol (● or ▼) can expose you to chemicals, including cadmium, which are known to the State of California to cause cancer and birth defects or other reproductive harm. For more information, visit P65Warnings.ca.gov.



Origami Paper Boxes

This book includes more than 25 inventive paper origami box projects, ranging from simple lidded classic forms to complex pentagonal, hexagonal, and octagonal boxes with integral twisted lids. Mark Bolitho. Paperback. 128 pages. 8" x 9".

NUMBER	DESCRIPTION	EACH	3/EA
A71279-1001	Paper Boxes Origami	\$22.04	\$19.84



Fold'em's Fold-by-Number Origami Papers

Create origami projects such as animals and finger puppets with these pre-printed, lightweight, easy-to-fold sheets. Packages include 12, 5-7/8" x 5-7/8" sheets and instructions.

NUMBER	DESCRIPTION	EACH	12/EA	24/EA
A11245-0025	Finger Puppets	\$5.84	\$5.25	\$4.99

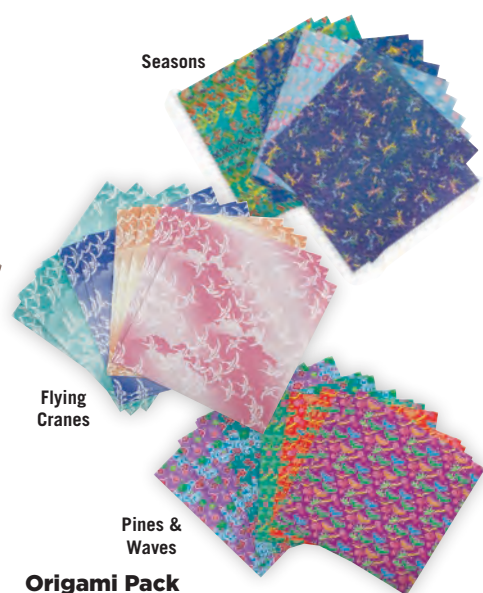

Flying Cranes

Seasons

Pines & Waves

Origami Pack

Use this patterned Japanese paper for traditional paper folding, or make unique greeting cards, scrapbook accents, and more. Each pack features 5-7/8" x 5-7/8" paper made with non-toxic colors.

NUMBER	DESCRIPTION	EACH	6/EA	12/EA
A11272-1004	Flying Cranes	\$5.89	\$5.30	\$5.04
A11272-1003	Seasons	5.89	5.30	5.04
A11272-1002	Pines & Waves	6.39	5.75	5.46



Yasutomo Student Origami Paper Class Packs

Each pack of authentic Japanese origami paper contains 10 assorted colors that reverse to white. Choose from three popular sizes. The price is perfect for practice!

500 Assorted Sheets				
NUMBER	SIZE	EACH	12/EA	24/EA
A63258-1004	4" x 4"	\$11.96	\$10.76	\$10.22
A63258-1006	6" x 6"	20.08	18.07	17.17
100 Assorted Sheets				
NUMBER	SIZE	EACH	12/EA	24/EA
A63258-1007	7" x 7"	\$12.36	\$11.12	\$10.57



Aitoh 100 Color Origami Paper Pack

Contains 200, 5-7/8" square sheets you can mix and match for dramatic results (two of each color). Papers are single-sided.

NUMBER	EACH	6/EA	12/EA
A01320-1005	\$15.42	\$13.88	\$13.18



Yasutomo Metallic Origami Squares

Lightweight and non-toxic, each package contains a brilliant assortment of the following colors: Scarlet, Fuchsia, Violet, Orange, Gold, Apple Green, Holly Green, Turquoise, Royal Blue, and Silver on one side, white on the other. 6" squares, 36 per package.

NUMBER	EACH	12/EA	24/EA
A11206-0369	\$5.23	\$4.70	\$4.46



Origami Jewelry Motifs

Learn to fold more than 30 charming origami shapes. Mix-and-match the jewelry-sized motifs with headbands, necklaces, rings, and more to create your own custom jewelry. Perfect for beginners and intermediate artists. Julian Laboy-Rodriguez. Paperback. 128 pages. 8" x 8".

NUMBER	DESCRIPTION	EACH
A71535-1001	Origami Jewelry Motifs	\$25.34



Yasutomo Origami Folk Art Assortment

Inspired by traditional Japanese folk art. The 6" squares have eight designs per 16-sheet package, and the 4-5/8" squares have 10 designs per 40-sheet package. Patterns on one side.

NUMBER	SIZE	EACH	12/EA	24/EA
A11206-0149	4-5/8" x 4-5/8"	\$3.65	\$3.28	\$3.12
A11206-0409	6" x 6"	3.65	3.28	3.12

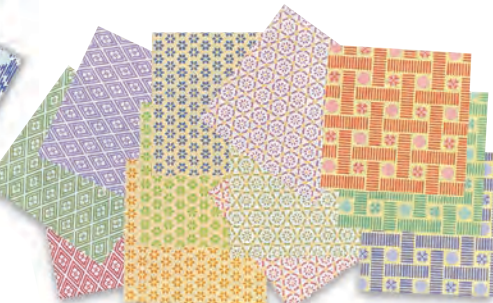

Aitoh Komon Print Chiyogami Paper

48 sheets in 12 styles of delicate geometric and floral patterns. Lightweight paper is easy to fold and comes in an assortment of colors. Great for all decorative paper projects as well as traditional origami. 5-7/8" square sheets.

NUMBER	EACH	6/EA	12/EA
A11210-1499	\$6.24	\$5.61	\$5.32



Yasutomo Paper Assortments

A rainbow of brightly colored squares, white on the reverse side.

Assortment #1 — 55 sheets: 29 of 3-1/2", 18 of 4-1/2", and 8 of 5-7/8" square. Includes instructions.

NUMBER	EACH	12/EA	24/EA
A11206-1559	\$4.75	\$4.27	\$4.05

Assortment #2 — 55 sheets: 29 of 4-1/2", 18 of 5-7/8", and 8 of 9-5/8" square. Includes instructions.

NUMBER	EACH	12/EA	24/EA
A11206-2559	\$7.97	\$7.17	\$6.81

Assortment #3 — 35 sheets, all 5-7/8" squares. One each of 35 colors.

NUMBER	EACH	12/EA	24/EA
A11206-0359	\$4.36	\$3.92	\$3.73



Aitoh Double-Sided Origami Papers

36 sheets, assorted bright colors. Color on back is different from color on front.

NUMBER	SQUARE	EACH	6/EA	12/EA
A11210-0069	5-7/8"	\$5.62	\$5.05	\$4.80
A11210-1369	7"	8.27	7.44	7.07



Pacon Large Origami Papers

A rainbow of brightly colored squares, white on the reverse side. 40 sheets per package, 9" square. Includes instructions for four projects.

NUMBER	EACH	12/EA	24/EA
A11207-1002	\$11.82	\$10.63	\$10.10



Yasutomo Gold and Silver Origami Papers

Packages of 25 non-toxic sheets, Gold or Silver on one side. Sheets measure 5-7/8" square.

NUMBER	COLOR	EACH	12/EA	24/EA
A11245-9015	Gold	\$5.84	\$5.25	\$4.99
A11245-2410	Silver	5.13	4.61	4.38



Roylco Really Big Origami Paper

Add big fun to classroom origami projects with these super-sized sheets featuring double-sided designs in six different patterns. The size makes folding easy for beginners. Package contains 30, 12" x 12" sheets.

NUMBER	EACH	12/EA	24/EA
A63255-1004	\$13.61	\$12.05	\$11.45

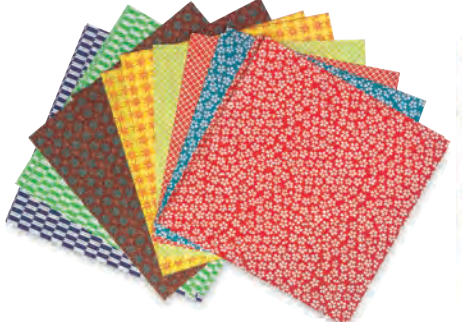

Aitoh Kimono and Folk Art Origami Paper

Each package contains five sheets in four unique patterns for a total of 20 sheets. The front features a smooth surface, while the back is textured. All colors are non-toxic. 5-7/8" square sheet.

NUMBER	PKG	EACH	6/EA	12/EA
A11210-1209	20 Sheets	\$3.17	\$2.85	\$2.71



Aitoh Chiyogami Paper

Complete instructions and project ideas are included in this pack of lovely, authentic Chiyogami papers. Each pack contains 24 origami sheets, with six each of four different designs.

NUMBER	EACH	6/EA	12/EA
A12234-1002	\$4.37	\$3.93	\$3.74



Folia Origami Sheets

These brightly colored square sheets come in assorted ready-to-use packs. Choose from two sizes for a variety of projects. Available in packs of 100 or 500 sheets. Lightweight, 70 gsm.

100 Assorted Sheets				
NUMBER	SIZE	EACH	6/EA	12/EA
A12233-1013	6" x 6"	\$8.41	\$7.57	\$7.19
A12233-1020	7-3/4" x 7-3/4"	13.03	11.72	11.13

500 Assorted Sheets				
NUMBER	SIZE	EACH	6/EA	12/EA
A12233-1033	6" x 6"	\$13.35	\$11.99	\$11.41
A12233-1040	7-3/4" x 7-3/4"	21.23	19.10	18.15



Aitoh Ancient Art of Origami Kit

If you've always wanted to learn this fascinating Japanese art form, here's a kit that will provide you with the materials and instructions you need. 68 sheets of paper — including colors, Oriental patterns, double-sided, and foils — in three sizes, plus a booklet that leads you step-by-step through the construction of 23 remarkable paper toys and animals. Fun and easy for children and adults.

NUMBER	EACH	12/EA	24/EA
A11245-0009	\$15.10	\$13.59	\$12.91



Yasutomo 1,000 Cranes Origami Paper Kit

Folding 1,000 paper cranes is an expression of hope and goodwill. Kit includes everything needed to create and display 1,000 colorful cranes; 1,020 sheets of 3" x 3" origami paper, a 197-ft string for hanging, and step-by-step instructions. This beautiful symbol is a great classroom project and a perfect gift for special celebrations or to wish someone health and long life.

NUMBER	EACH	6/EA	12/EA
A12607-1009	\$23.05	\$20.73	\$19.70



Arnold Grummer's Zig-Zag Book Classroom Packs

Beginning artists will enjoy filling these accordion-fold books with stories and pictures. The heavyweight, acid-free, six-panel inserts are pre-folded so kids can get right to work. Each pack includes enough materials to make 12 books, including 24 sturdy chipboard covers, 12 inserts, a cover template, project suggestions, and simple instructions.

NUMBER	SIZE	EACH	12/EA
A62802-1045	4-1/2" x 4-1/2"	\$17.95	\$16.16
A64208-1001	4-1/2" x 5-3/4"	18.73	16.85
A62001-1009	4-1/2" x 8-3/4"	26.20	23.57



Books by Hand "Designed by Me" Blank Cover Bookbinding Kits

Create beautiful, professional-quality books in a variety of styles. (You provide scissors or a craft knife, PVA paper glue, a ruler, and other supplies.)

Classic Codex Style Book Kit — Makes one 24-page 5-1/4" x 7-1/4" book.

NUMBER	EACH	12/EA
A12648-1057	\$16.89	\$15.20

Classic Codex Style Book Class Pack — Makes 10, 5-1/4" x 7-1/4" books.

NUMBER	EACH	12/EA
A12648-1157	\$132.33	\$119.09

Dos-a-Dos Coptic Journal Kit — Makes one 80-page 4-1/4" x 4-1/4" book.

NUMBER	EACH	12/EA
A12648-1044	\$20.75	\$18.68

Japanese Stab Binding Book Kit — Makes three 4" x 6" books.

NUMBER	EACH	12/EA
A12648-1046	\$26.49	\$23.84

Tibetan Style Book Kit — Makes two books, one 4-1/4" x 6-1/4" and the other 5" x 7-1/2".

NUMBER	EACH	12/EA
A12648-1146	\$27.55	\$24.79

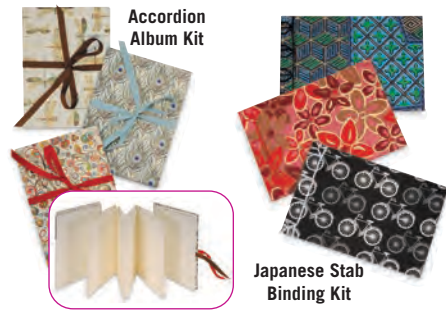

Books by Hand Bookmaking Kits

For complete kit contents, visit DickBlick.com.

Accordion Album Kit — Makes three 5-1/4" x 7-1/4" albums with the following covers: Dragonflies, Peacock Feathers, and Art Nouveau Flowers.

NUMBER	EACH	12/EA
A12649-1001	\$27.55	\$24.79

Japanese Stab Binding Kit — Makes three 4" x 6" 16-page sewn books with the following covers: Blue Geometric, Pink-Red Flowers, and Bicycles.

NUMBER	EACH	12/EA
A12649-1003	\$27.55	\$24.79



Richeson Bookmaking Class Packs

Kids can make their own unique journals or sketchbooks with these all-in-one kits, which include paper and black binding coils. Decorate the covers with paint, fabric, markers, paint pens, or other materials. For details, visit DickBlick.com.

NUMBER	SIZE	EACH
A64210-1066	6" x 6", 12 Books	\$47.22
A64210-1069	6" x 9", 30 Books	76.26
A64210-1912	9" x 12", 15 Books	75.70



6-3/4" x 4-1/2"

4-1/2" x 6-3/4"

Fabriano Medioevalis Cards

These alpha cellulose cards are excellent as pages for handmade books. The creamy white mouldmade paper accepts pen, pencil, charcoal, pastel, light washes, stamping, and inkjet printing. Made in Italy. Packages of 100, 260 gsm.

NUMBER	DESCRIPTION	EACH	5/EA
A10032-1060	Portrait Folded Cards	\$65.50	\$58.95
A10032-1050	Landscape Folded Cards	65.50	58.95



Making Books

This definitive manual offers a comprehensive overview on the tools, principles, and techniques used in bookbinding by hand. London Centre for Book Arts. Hardcover. 192 pages. 8" x 10".

NUMBER	DESCRIPTION	EACH
A71534-1001	Making Books	\$36.74



Lineco Acid-Free Binder's Board

Heavy, gray cardboard for making hardbound books. Ready to cut with sharp utility knife or paper trimmer. Package of four 15" x 20-1/2" sheets.

NUMBER	THICKNESS	EACH	6/EA
A12827-1007	.067"	\$19.71	\$17.74
A12827-2007	.082"	22.53	20.28
A12827-3007	.098"	26.69	23.99

Cover-It Book Kit

Small books easy for children to make and decorate. Kit includes enough materials to make 12, 5-1/2" x 3-1/2" books: 80 pre-glued pages of 80 lb paper, page and binding support strips, and chipboard covers. Components are recycled, recyclable, and made in the USA.

NUMBER	EACH	12/EA
A12780-1009	\$28.35	\$25.52



Cover-It Mini Accordion Book Kit

Materials make 72 mini accordion-fold books. The pre-scored 10-panel strips help children make precise accordion folds, so they can get right to work covering and decorating their books. Finished books measure approximately 2-3/8" x 1-1/2". Components are recycled, recyclable, and made in the USA.

NUMBER	SIZE	EACH	6/EA
A12774-1009	Pkg of 72	\$42.76	\$38.48



Books By Hand Linen Thread

Fine linen bookbinding thread with the correct thickness (38 gauge, 3-ply) for sewing signatures. Unbleached, unwaxed, and unsized. 50 yds long.

NUMBER	EACH	6/EA
A12841-1050	\$9.26	\$8.33



Lineco Book Board Hole Punch

Use to punch 1/4"Dia holes in heavy book board for binding with ribbon. Heavy-duty alloy steel, hardened cutting edge, self-cleaning. 4" long.

NUMBER	EACH	6/EA
A12839-1000	\$19.39	\$17.45



A-B Books By Hand Awls

A Light-Duty Awl — Suitable for "stab" style book binding. Thin, precision-hardened steel point will penetrate an entire book signature. 6" long with 4" wooden handle.

NUMBER	EACH	6/EA
A12843-1000	\$5.17	\$4.65

B Heavy-Duty Awl — Heavy-duty awl is 5-1/8" long with a 3-1/2" handle that can be tapped with small hammer to penetrate heavier materials. Precision-hardened steel point maintains sharpness.

NUMBER	EACH	12/EA
A12842-1000	\$5.76	\$5.18



C-D Lineco Awls for Hole Punching

Designed for easy gripping and sewing, these awls have precision-hardened steel points.

C Medium-Duty Awl — Stainless steel with a ribbed body and curved head.

NUMBER	EACH	6/EA
A12868-1000	\$11.56	\$10.42

D Heavy-Duty Awl — The wood handle allows for good control and a strong grip.

NUMBER	EACH	6/EA
A12868-1003	\$21.13	\$19.04

E Extra-Heavy Duty Awl with Ball Handle — Rests nicely in the palm for ergonomic comfort and power.

NUMBER	EACH	6/EA
A12868-1001	\$15.99	\$14.41



Lineco Beeswax

For waxing thread to reduce tangles. 2-1/2" x 3/4" x 1/2" block.

NUMBER	EACH	6/EA
A12826-0003	\$8.08	\$7.27



Waxed Thread

This strong, five-cord waxed thread is ideal for hand-stitching. Smooth and consistent, it won't stretch or break. Made in the USA. Approximately 150 yds per spool.

NUMBER	COLOR	EACH	12/EA
A63012-2024	Black	\$16.53	\$14.87
A63012-8004	Brown	16.53	14.87
A63012-8234	Tan	16.53	14.87
A63012-1024	White	16.53	14.87



Book Rings

These sturdy metal book rings are a great teacher's helper. Use them to bind a book or keep flash cards or other papers securely fastened together. Easy to open and close. Packs of 50.

NUMBER	SIZE	EACH	12/EA
A64203-1001	1"	\$7.63	\$6.87
A64203-1002	2"	14.19	12.67

F Assorted Metallic Colors

NUMBER	SIZE	EACH	12/EA
A64203-1003	1"	\$10.90	\$9.82
A64203-1004	2"	16.37	14.62



Screw Posts

Typically used to bind photo albums and memory books. Heavy-duty aluminum. Package of six.

NUMBER	SIZE	EACH	6/EA
A12846-1009	7/8"	\$4.09	\$3.68
A12846-1002	1-3/4"	4.75	4.27



F-G Books by Hand Waxed Linen Thread

Lightly waxed natural 5-ply linen thread for bookbinding, crafts, and art. Each package contains three 20 yd spools.

F Basic Pack — Black, Tan, and Purple.

NUMBER	EACH	6/EA
A64209-1020	\$13.08	\$11.77

G Neutral Pack — Natural, Black, and Brown.

NUMBER	EACH	6/EA
A64209-1120	\$13.08	\$11.77

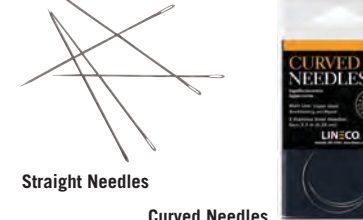

Straight Needles

Curved Needles

Lineco Binder's Needles

Sized to accommodate sturdy bookbinding threads, these needles have a length that's easy to handle and a slightly blunted point to reduce paper snags. Manufactured from the finest grade steel. Pack of 5.

NUMBER	DESCRIPTION	EACH	12/EA
A12722-1005	Straight	\$8.80	\$7.93

Curved Needles — Perfect for coptic stitch bookbinding and book repair. 1-1/2"Dia. Pack of 3.

NUMBER	DESCRIPTION	EACH	12/EA
A12659-1001	Curved	\$8.32	\$7.48



Lineco Bone Folders and Scorer

Smooth-edged tools for making precise creases in paper, embossing, and burnishing. Invaluable for fibrous and heavy decorative papers. Made with real bone. Small is 6"L x 7/8"W. Large is 8"L x 1"W. Scorer is 4-3/4" x 1-1/4".

NUMBER	SIZE	EACH	12/EA
A12964-0001	Small	\$7.26	\$6.49
A12964-0003	Large	9.82	8.83
A12964-1000	Scorer	10.87	9.78



Bone Folders and Scorer

Genuine bone tools. Comfortable and easy to handle, they offer great quality at an economical price. Small: 6"L x 7/8"W. Large: 8"L x 1"W. Scorer: 4-3/4"L x 1-1/4"W.

NUMBER	DESCRIPTION	EACH	12/EA
A64214-1678	Folder, Small	\$6.54	\$5.89
A64214-1081	Folder, Large	9.82	8.84
A64214-3414	Scorer	7.63	6.87



Lineco Bookbinding Tool Kit

This kit is perfect for beginner bookbinders and craft makers, with tools carefully selected for quality and ease of use. For set contents, visit DickBlick.com.

NUMBER	EACH	6/EA
A12665-1001	\$43.15	\$38.83



Lineco Book Repair Kit

This six-piece kit includes the basic supplies needed for simple book repair, cleaning, and conservation. For contents, visit DickBlick.com.

NUMBER	EACH
A12658-1001	\$51.65



Lineco Book Repair Tape

Strong linen fabric tape for attaching covers to signatures, assembling cover blanks, and general repair. This gummed tape is water-activated and acid-free. White.

NUMBER	SIZE	EACH	6/EA
A12754-1001	1"W x 36"	\$9.20	\$8.27
A12754-1002	2"W x 48"	10.64	9.57



Arnold Grummer's Papermill Station for Groups

Supplies to make up to 40, 5-1/2" x 8-1/2" sheets per session. All supplies are reusable. Includes Papermill Station Guide, finished hardwood deckle, three paper making screens, three cover screens, two drain racks, 80 reusable couch sheets, two sponges, press bar, envelope pattern, illustrated directions, and 1 oz sample of specialty pulp. Recommended for 4th grade and older.

NUMBER	EACH
A60996-0009	\$108.03



Arnold Grummer's Dip Into Papermaking I Classroom Kit

Everything needed for a classroom to create multiple paper projects! Contains four medium dip handmolds, press-and-dry sheets, sponges, press bars, cotton fiber, templates, decorative additives, and teacher's setup guide.

NUMBER	EACH
A12822-1010	\$180.17

ARNOLD GRUMMER'S



Arnold Grummer's Paper Press

This fully assembled paper press is handcrafted from Baltic birch and allows up to 2,000 lb of even pressure to be applied with easy hand cranking. Use for papermaking and related art applications such as drying and pressing botanicals, bookbinding, printmaking, or anything requiring high pressure. This system removes water to quicken the drying process and produces a harder finished surface than paper pressed by hand. Multiple pulp sheets can be dried simultaneously. For best drying results, use with Couch Sheets. Unique textures can be achieved by pressing with alternative materials such as linen or burlap. Standard Press — sizes up to 8-1/2" x 11". Weighs 22 lb. Large Press — sizes up to 11-1/2" x 14-1/2". Weighs 28 lb. FOB Factory. See page 648 for details.

NUMBER	SIZE	EACH
AF12838-1001	Standard, 8-1/2" x 11"	\$350.00
AF12838-1002	Large, 11" x 14"	375.00

Books By Hand PVA Glue Adhesive Kit

This excellent assortment includes a 4 oz bottle of pH-neutral PVA adhesive, brushes, a bone folder, glue tips, and a tray.

NUMBER	EACH	6/EA
A12844-1001	\$26.60	\$23.94



Making Handmade Books

Learn more than 100 bindings, structures, and forms. In as little as an afternoon, beginners will be on their way to folding, gluing, and sewing handmade books in a variety of shapes and styles. Fuel your bookbinding adventures with this accessible collection of projects. Alisa Golden. Paperback. 256 pages. 8-1/2" x 10".

NUMBER	EACH
A71269-1001	\$21.99



Lineco Spine Repair Tape

A self-adhesive tape made from superior thread-count cloth and specially formulated adhesive. Use to permanently repair or reinforce book spines, or to reattach book covers. 2" wide, 15 yd roll.

NUMBER	COLOR	EACH	6/EA
A12754-2040	Black	\$25.28	\$22.74
A12754-1030	White	25.28	22.74



Arnold Grummer's Papermill Pro Station for Groups

This kit is the same as the Papermill Station for Groups except it makes 8-1/2" x 11" paper and includes a slide-in template for making handmade paper envelopes. Kit contains: hardwood pour handmold, envelope template, three paper making screens, three cover screens, two screen support grids, two sponges, press bar, 80 large couch sheets, 8 oz cotton linter, 1 oz specialty pulp, directions, and a guidebook for teachers.

NUMBER	EACH
A60996-1009	\$174.68



Arnold Grummer's Dip Into Papermaking II Classroom Kit

Contains three large handmolds, paper making screen, cover screen, support grid, three sponges, three large press bars, 48 reusable press-and-dry cloths, three botanical packs, three metallics, three full-size fiber sheets, four envelope templates, and teacher's setup guide.

NUMBER	EACH
A12822-2009	\$191.09



A Books By Hand Polyvinyl Acetate (PVA)

This professional-quality adhesive dries acid-free, solvent-free, and water-soluble. For bookbinding and all paper projects.

NUMBER	SIZE	EACH	6/EA
A12844-1004	4 oz	\$5.47	\$4.92
A12844-1005	8 oz	7.70	6.93
A12844-1006	16 oz	12.52	11.27
A12844-1009	Gallon (3.78 Liter)	87.52	78.77

B Lineco Glue Brushes

Designed for bookbinding and other adhesive applications, the dense natural bristles in these brushes load and carry lots of glue, and spread it evenly over large surfaces. Metal-free; will not rust.

NUMBER	SIZE	EACH	6/EA
A24922-5012	1/2"	\$8.52	\$7.63
A24922-5034	3/4"	9.82	8.83

Yes! Stik Flat Glue

All-purpose, lay-flat, white glue. Used by bookbinders, printers, libraries, greeting and sample card makers, to name a few. Won't buckle paper. Acid-free, smooth flowing, permanently flexible. Low odor and easy cleanup. Pint.

NUMBER	EACH	12/EA
A23836-0006	\$15.59	\$14.03



Lineco Transparent Mending Tissue

This very thin, pressure-sensitive mending tissue is extremely transparent, making it ideal for repairing documents and torn pages in books. Archival and pH-neutral, it also resists yellowing over time. To use, dispense a length of tissue, place it over the tear, and burnish the area with a bone folder. Working the adhesive into the tear strengthens the paper as it covers and supports the surrounding area. Removable with solvents.

NUMBER	SIZE	EACH	6/EA
A12754-1005	1/2"W x 50 ft	\$13.58	\$12.21



Lineco Pad Compound

Make your own paper pad! Simply stack sheets, clamp together, and brush this adhesive onto one side. Glue will bind paper but will allow sheets to be removed one at a time. Dries translucent white and flexible. 12 oz.

NUMBER	EACH	6/EA
A12752-1012	\$22.58	\$20.32



Lineco Satin Cloth Tapes

Self-adhesive, non-yellowing tapes are made from a strong, acid-free fabric with a low-luster finish — ideal for archival applications. Use them to join the edges of boxes, for hinging album pages, or for adding a finishing touch to board edges. 1"W x 36 ft.

NUMBER	COLOR	EACH	6/EA
A12754-2050	Black	\$19.38	\$17.45
A12754-1050	Ivory	19.38	17.45



Scotch #845 Book Tape

Durable, conformable, crystal-clear tape for repairing, reinforcing, protecting bound edges and surfaces of books, magazines, and more. Also for hinging and laminating. Very strong bond. Will not crack or dry out. 3" core.

NUMBER	SIZE	EACH	6/EA
A23021-1015	1-1/2" x 15 yd	\$7.91	\$7.38
A23021-1002	2" x 15 yd	10.75	10.03
A23021-1003	3" x 15 yd	16.38	15.28
A23021-1004	4" x 15 yd	21.87	20.40



Arnold Grummer's Papermill Complete Kit

Professional-quality supplies to form, press, and dry your own sheets of 5-1/2" x 8-1/2" paper: dip hand mold, two screens, support grid, 20 couch sheets, sponge, press bar, envelope pattern, and "Arnold Grummer's Guidebook" with instructions for six projects.

NUMBER	EACH
A12821-2009	\$73.37



The Super Tub

Versatile tub for a number of projects, including etching, paper making, and fabric dyeing. Made of durable, heavy-duty black plastic. 8" deep. Bottom measures 30" x 22".

NUMBER	EACH	3/EA
A46904-0000	\$30.38	\$27.34



Arnold Grummer's Dip Handmold Kits

Making custom paper sheets is fun and easy with these kits from Arnold Grummer. Kits contain a handmold frame (deckle), papermaking screen, cover screen, support grid, and botanicals.

NUMBER	SIZE	EACH	6/EA
A12822-1000	8-1/2" x 11"	\$36.03	\$32.43
A12822-1029	5-1/2" x 8-1/2"	29.29	26.35

Arnold Grummer's Specialty Pulps

Pre-shredded, blender-friendly pulps can be used alone or in combination with standard pulps for added texture, shreds, or flecks in papermaking or papercasting. 8 oz bag.

NUMBER	EACH	12/EA
A12831-1025	\$10.99	\$9.91
A12831-1005	8.80	7.93



A-J Roylco® Decorative Papers

Paper craft projects make learning fun. Each package includes a free idea guide.
A Global Village — 48 sheets in 12 beautiful designs from around the world, each representing a country's heritage. Eight designs 8" x 8", and four designs 4" x 8".

NUMBER	STYLE	EACH	6/EA	12/EA
A11262-1000	Global Village	\$8.83	\$7.94	\$7.54

B Animal — Eight hand-painted animal designs reproduced on 8-1/2" x 11" paper. 40 sheets per package.

NUMBER	STYLE	EACH	6/EA	12/EA
A11262-1020	Animal	\$8.83	\$7.94	\$7.54

C Stained Glass — Eight unique stained glass textures printed on translucent paper. 24 sheets per package of 5-1/2" x 8-1/2" paper.

NUMBER	STYLE	EACH	6/EA	12/EA
A11262-1030	Stained Glass	\$8.83	\$7.94	\$7.54

D Tie Dye — 16 different tie-dye designs, printed on both sides, offer more variety for any paper craft project. 32 sheets per package of 8-1/2" x 11" paper.

NUMBER	STYLE	EACH	6/EA	12/EA
A11262-1050	Tie Dye	\$8.99	\$8.13	\$7.70

E African Textile — Eight patterns representing kente, colorful African strip-woven cloth native to Ghana and Togo. 32 sheets per package of 8-1/2" x 11" paper.

NUMBER	STYLE	EACH	6/EA	12/EA
A11262-1080	African Textile	\$8.83	\$7.94	\$7.54

F Antique — Use these parchment-style papers to help illustrate poems and short stories using medieval lettersets and scripts. Draw an antiqued family tree, family coat of arms, or a realistic treasure map. 32 sheets of 8-1/2" x 11" paper.

NUMBER	STYLE	EACH	6/EA	12/EA
A11262-1150	Antique	\$10.19	\$9.17	\$8.73

G Down Under — Eight original Aboriginal designs reproduced on 32 sheets of 8-1/2" x 11" paper. Also includes eight reproducible line drawings for coloring.

NUMBER	STYLE	EACH	6/EA	12/EA
A11262-1130	Down Under	\$8.83	\$7.94	\$7.54

H Patterned Paper — Enhance any project with this colossal collection of 248 colorful craft papers. Includes 40, 8-1/2" x 11" sheets of animal, fabric, and sea life papers, and 16, 8-1/2" x 11" sheets each of skin tone, African textile, Native American, Hispanic, autumn, spring, holiday, and Valentine papers.

NUMBER	STYLE	EACH	6/EA	12/EA
A11262-1170	Patterned Paper	\$41.54	\$37.38	\$35.52

I Around the World — A complete set of gorgeous papers perfect for ethnic and traditional crafts. Includes African, Native American, Asian, Hispanic, Middle Eastern, and Down Under. Two 8-1/2" x 11" sheets each of 48 designs.

NUMBER	STYLE	EACH	6/EA	12/EA
A11262-1140	Around the World	\$16.99	\$15.31	\$14.54

J Retro Pop — Let these authentic patterns take you back to the 1960s! Includes 16 designs, two per sheet, ideal for greeting cards, scrapbooks, collage, invitations, and more. 32 sheets per package of 8-1/2" x 11" paper.

NUMBER	STYLE	EACH	6/EA	12/EA
A11262-1190	Retro Pop	\$9.99	\$8.99	\$8.56

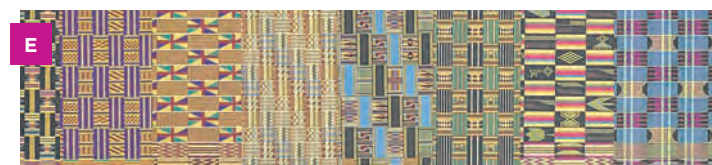

AITOH® JAPANESE DECORATIVE PAPERS



Available in individual sheets, these highly decorative papers are great for bookbinding, collage, framing, invitations, and paper arts of all kinds. Choose from a variety of colorful patterns inspired by nature.



Birds/Flowers Multicolor



Black/White/Red/Purple Flowers



Blue/Cherry Blossoms



Blue/Pink/White Petals

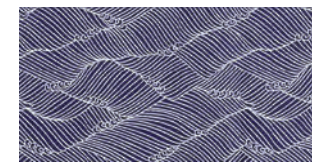

Blue Wave

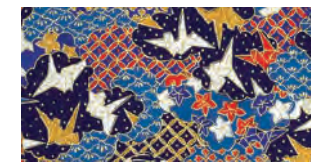

Red/White/Blue/Gold Cranes



Chrysanthemum



Gold/Blue with Cranes



Gold/Pink/White Flowers



Flower Bouquet

NUMBER	COLOR	SIZE	EACH	10/EA
A12654-1010	Birds/Flowers Multicolor	31-1/2" x 22"	\$10.36	\$9.32
A12654-1012	Black/White/Red/Purple Flowers	21-1/2" x 31-1/2"	10.36	9.32
A12654-1008	Blue/Cherry Blossoms	25" x 18-1/2"	10.36	9.32
A12654-1006	Blue/Pink/White Petals	25" x 18-1/2"	8.73	7.85
A12654-1013	Blue Wave	31-1/2" x 31-1/2"	12.77	11.49
A12654-1003	Red/White/Blue/Gold Cranes	25" x 18-1/4"	10.91	9.81
A12654-1011	Chrysanthemum	18-3/4" x 25"	10.36	9.32
A12654-1009	Gold/Blue with Cranes	31-1/2" x 21-1/2"	9.82	8.83
A12654-1005	Gold/Pink/White Flowers	25-1/2" x 19"	9.03	8.13
A12654-1002	Flower Bouquet	26" x 19-1/4"	13.09	11.78



K Black Ink™ Egyptian Papyrus Papers

Papyrus is the oldest writing material in existence today, dating back at least 5,000 years. In fact, the very word "paper" is derived from its name. These light-colored sheets are formed by laying thin strips of plant stalk in horizontal and vertical (crosswise) layers. They have better mechanical strength than many modern papers of the same weight. Use them for writing, drawing, or painting. Paper sizes are approximate, and edges may or may not be frayed.

NUMBER	DESCRIPTION	SIZE	EACH	10/EA
A11239-1003	Light	8" x 12"	\$3.92	\$3.53
A11239-1006	Light	12" x 16"	5.63	5.06
A11239-1015	Dark	16" x 24"	9.44	8.52
A11239-1012	Flecked Light	16" x 24"	10.80	9.72
A11239-1011	Light	16" x 24"	9.44	8.52
A11239-1013	Speckled Med	16" x 24"	10.80	9.72

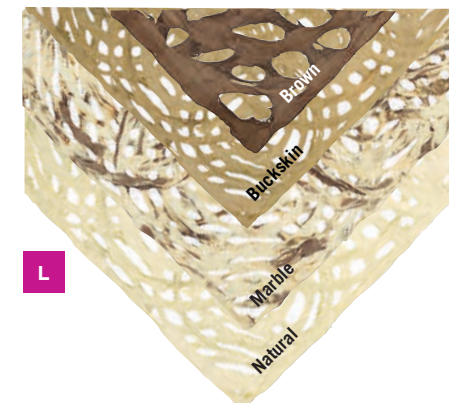

L Black Ink™ Circulous Amate Paper

Handmade by the Otomi Indian artisans of Mexico, the culture of amate paper dates back to pre-Columbian Mesoamerican times. The Otomi people still use amate paper today for creating cutout figures for religious ceremonies, while other village artisans use it for Mexican folk art depicting urban scenes, festivals, and celebrations. This acid-free, 150 gsm paper is a wonderful choice for acrylic and gouache painting, ink and pastel drawings, crafts, invitations, cards, block printing, bookmaking, and bookbinding. Sheets vary in shade, color, weight, and pattern. The size (approximately 15-1/2" x 23-1/2") also may vary due to the deckle edges and the vagaries of the drying process.

NUMBER	COLOR	EACH	10/EA
A12498-8020	Brown	\$14.73	\$13.25
A12498-8090	Buckskin	14.73	13.25
A12498-8230	Marble	14.73	13.25
A12498-8540	Natural	14.73	13.25

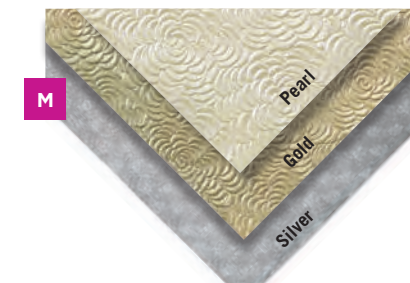

M Black Ink™ Zinnia Embossed Paper

Embossed with an elegant zinnia design, these handmade papers are coated with either a metallic or pearl finish. Use them to add dimension to invitations, books, mixed media projects, and more. Made from 100% recycled cotton rag. Acid-free. 110 gsm. 22" x 29-1/2" sheets.

NUMBER	COLOR	EACH	10/EA
A09916-9010	Gold	\$8.73	\$7.85
A09916-1090	Pearl	8.73	7.85
A09916-9330	Silver	8.73	7.85

N Glitter Lotka Paper

Simple technology and ancient paper making processes create these one-of-a-kind, eco-friendly papers. The paper is handmade from 100% Lotka fibers, which are collected by Nepalese farmers and Village Co-operatives from the community forest, then hand-silkscreened. Acid-free, 60 gsm sheets have four deckle edges. For paper crafts, gift wrapping, journals, and scrapbooks.

NUMBER	COLOR	EACH	10/EA
A12609-9513	Copper	\$6.81	\$6.12
A12609-9113	Gold	6.81	6.12
A12609-9333	Silver	6.81	6.12

DECORATIVE PAPERS

A-M Lokta Paper Packs — The Nepalese Collection

Each pack contains 12 sheets of A4 size (8.27" x 11.69") paper in various designs.

NUMBER	DESCRIPTION	EACH	12/EA	24/EA
A12495-3010	A Red/Cream	\$14.28	\$12.85	\$12.21
A12495-3060	B Magenta/Pink	14.28	12.85	12.21
A12495-5010	C Blue/Orchid	14.28	12.85	12.21
A12495-7020	D Sage/Green	14.28	12.85	12.21
A12495-4280	E Yellow/Orange	14.28	12.85	12.21
A12495-1100	F Cream	14.28	12.85	12.21
A12495-1110	G Cream/Silver	14.28	12.85	12.21
A12495-1120	H Animal/Grunge	14.28	12.85	12.21
A12495-1000	I Batik	14.28	12.85	12.21
A12495-1001	J Dots/Stripes	14.28	12.85	12.21
A12495-1101	K Gold/Cream	14.28	12.85	12.21
A12495-1010	L Metallic	14.28	12.85	12.21
A12495-5000	M Marble Blue	14.28	12.85	12.21

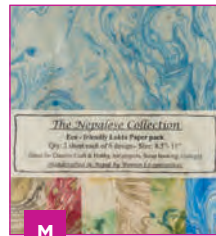

Handmade Paper by the Pound

These beautiful handmade papers for collage, card making, rubber stamping, and other projects are made from 100% post-consumer recycled cotton fabric waste. Durable and practically priced, each pack offers a random assortment from a range of 200 designs. Sheets are compatible with drawing and painting materials.

NUMBER	SIZE	EACH	12/EA
A11298-1002	8-1/2" x 11"	\$15.37	\$13.83
A11298-1005	11" x 15"	15.37	13.83



Decorative Paper Assortments

Each beautiful package contains a dazzling array of handmade papers in 4" x 4", 6" x 4", and 5" x 7" sizes. Assorted colors and textures are screenprinted, embossed, mottled, block printed, embroidered, and flocked. Made from 100% post-consumer fiber.

NUMBER	DESCRIPTION	EACH	12/EA	24/EA
A12440-1005	1/2 lb Package	\$13.41	\$12.07	\$11.46
A12440-1001	1 lb Package	20.13	18.11	17.21

N-AA Decorative Paper Value Packs

Make your paper projects bright and color-coordinated! Each pack contains 18, 8-1/2" x 11" sheets, three each of six designs of embossed, screenprint, dew print, and glitter print papers. Handmade from 100% recycled, post-consumer waste.

NUMBER	DESCRIPTION	EACH	12/EA	24/EA
A12293-4510	N Orange and Yellow	\$12.55	\$11.29	\$10.72
A12293-4520	O Red and Dark Red	12.55	11.29	10.72
A12293-6510	P Dark Purple, Copper, and Hot Pink	12.55	11.29	10.72
A12293-5080	Q Turquoise and Teal	12.55	11.29	10.72
A12293-8360	R Cocoa and Teal	12.55	11.29	10.72
A12293-5510	S Olive and Teal	12.55	11.29	10.72
A12293-6460	T Purple and Violet	12.55	11.29	10.72
A12293-1030	U Burlap	12.55	11.29	10.72
A12293-5130	V Blue and Turquoise	12.55	11.29	10.72
A12293-5970	W Blue and Silver	12.55	11.29	10.72
A12293-6000	X Purple and Orange	12.55	11.29	10.72
A12293-7030	Y Moss Green and Black	12.55	11.29	10.72
A12293-7520	Z Moss Green and Pistachio Green	12.55	11.29	10.72
A12293-8160	AA Beige and Cocoa	12.55	11.29	10.72



Thai Unryu Decorative Papers

Long, swirling kozo strands add texture and contrast to colorful, translucent sheets. Machine-made in Thailand from 100% kozo. 25 gsm. 25" x 37" sheets.

NUMBER	COLOR	EACH	10/EA
A11234-1010	Aubergine	\$3.81	\$3.43
A11234-2000	Black	3.81	3.43
A11234-5010	Blue	3.81	3.43
A11234-3180	Burgundy	3.81	3.43
A11234-7010	Golden Green	3.81	3.43
A11234-7020	Green	3.81	3.43
A11234-6120	Lavender	3.81	3.43
A11234-3560	Mauve	3.43	3.09
A11234-3010	Red	3.81	3.43
A11234-8120	Sienna	3.81	3.43
A11234-1020	White	3.81	3.43
A11234-4010	Yellow	3.81	3.43

Did you know we have hundreds of lesson plans designed to meet the National Standards for Visual Arts Education? See them all at DickBlick.com/lesson-plans.



Lama Li™ Lokta Papers

Handmade and air-dried in Nepal, Lokta fibers produce strong sheets with interesting variations. A staple for fine artists, printers, and crafters, each sheet is acid-free with four deckle edges. 60 gsm. 20" x 30" sheets.

NUMBER	COLOR	EACH	10/EA
A12255-5010	Blue Lagoon	\$5.45	\$4.90
A12255-7050	Emerald Green	5.45	4.90
A12255-3113	Garnet	5.45	4.90
A12255-6140	Magenta	5.45	4.90
A12255-1370	Natural	5.45	4.90
A12255-4510	Orange	5.45	4.90
A12255-4580	Pumpkin	5.45	4.90
A12255-3360	Raspberry	5.45	4.90
A12255-7440	Spring Green	5.45	4.90
A12255-4250	Sunshine	5.45	4.90
A12255-5883	True Blue	5.45	4.90
A12255-5133	Ultra Blue	5.45	4.90
A12255-8910	Walnut	5.45	4.90

Criss Cross Thai Paper

Cotton strings applied in a random pattern give this soft, handmade mulberry paper a woven appearance that adds texture and depth to lanterns, paper crafts, and framed art. Subtle water dimpling adds even more dimension. 50 gsm. pH-neutral. 23-1/2" x 34" sheets have a fringed edge.

NUMBER	COLOR	EACH	10/EA
A09913-2020	Black	\$9.09	\$8.18
A09913-1370	Natural White	9.09	8.18



Black Ink™ Thai Embossed Paper

Handmade in Thailand of 100% kozo, these heavyweight embossed papers are excellent for the book arts, and also make beautiful invitations and displays. White, with a high relief pattern. Four deckle edges. 22" x 30" sheets.

NUMBER	DESCRIPTION	COLOR	EACH	10/EA
A11249-1002	Lucky Clover	White	\$9.17	\$8.24



Black Ink™ Thai Mulberry Beehive Paper

Textured circles of raised mulberry pulp create a beehive effect on this remarkably thin, sheer paper. Perfect for lampshades, glass lamps, luminaria, window shades, card making, and collage. 40-50 gsm. pH-neutral. 25" x 37" sheets.

NUMBER	COLOR	EACH	10/EA
A12286-2027	Black	\$6.60	\$5.94
A71457-1117	White	8.80	7.93



Black Ink™ Thai Melook Lace Paper

Inspired by the net-like surface of a melon, this paper is great for interior design projects such as lampshades or wall hangings. It can also be used to add interest to collages, bookbinding, and more. Acid-free. 45-50 gsm. 26-1/2" x 35" sheets.

NUMBER	COLOR	EACH	10/EA
A09909-2000	Black	\$12.62	\$11.36
A12490-1350	White	12.40	11.16

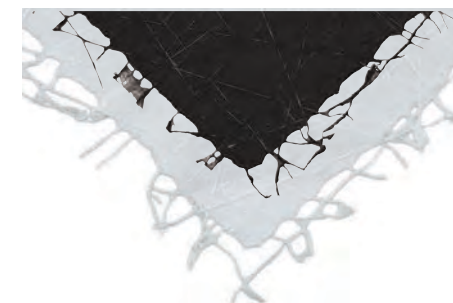

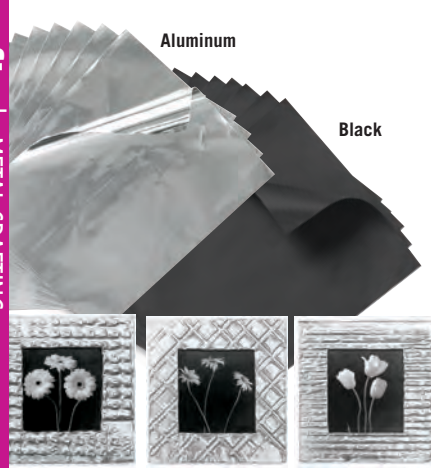

AMACO ArtEmboss Value Packs

These soft aluminum sheets are safe for younger artists — there are no sharp edges like regular tooling foil. Choose lightweight sheets (matte Black on both sides) or medium-weight sheets (either Aluminum on both sides or matte Black on one side/Aluminum on the other). Black will not chip off when tooled with a pencil. Sold in economical bulk packs containing 12, 9-1/4" x 12" sheets.

NUMBER	DESCRIPTION	COLOR	EACH	12/EA
A60518-2050	Light-weight	Black	\$21.83	\$19.65
A60518-2060	Medium-weight	Black/Aluminum	32.09	28.86
A60521-2830	Medium-weight	Aluminum	25.19	22.67



K&S Metal Sizes and Shapes

Ideal for model building, crafting, jewelry making, and much more. Each 1 lb bag contains a great selection of carefully engineered metal pieces in brass, aluminum, copper, and stainless steel. Shapes include a random mix of rods, strips, sheets, and tubing in a variety of sizes.

NUMBER	SIZE	EACH	6/EA
A33719-7070	1 lb	\$22.92	\$20.63



Studio Pro™ Hobby 100 Soldering Iron

An economical choice for production, studio, and classroom use, this lightweight, 100W soldering iron heats up to 1000°F. The 1/4" iron chisel-style tip is ideal for standard glass projects. Features a "stay-cool" insulated comfort-grip handle. May be used with a temperature controlling device. One-year manufacturer's warranty excludes tip.

NUMBER	EACH	6/EA
A61707-1001	\$21.19	\$19.07



AMACO ArtEmboss

Extremely soft, pliable metal rolls in bright metallic colors. 3 mil lightweight sheets accept the most intricate detail. 5 mil medium weight sheets are great for embellishing crafts or creating works of fine art. Wooden stylus included.

9-1/4" x 12" Rolls

NUMBER	COLOR	SIZE	EACH	12/EA
A60512-2820	Aluminum	5 mil	\$10.81	\$9.73
A60512-8210	Copper	3 mil	15.43	13.88
A60512-8200	Copper	5 mil	18.39	16.55
A60512-2050	Black	3 mil	7.50	6.75



Mini Tropical Punch 100 Pack

Six delightful 2" tropical designs to punch: Palm Tree, Fish, Sailboat, Toucan, Seashell, and Beach Scene, plus 100 plain white cardboard frames (4" x 4" outside dimensions), 25 plastic-handled needles for punching holes, a 4-1/2" x 20 ft roll of Colorfoil, masking tape, pattern sheets, and instructions. Makes 100 projects.

NUMBER	EACH	12/EA
A60501-1000	\$42.39	\$38.15



Metal Smith Molds for Tooling

Create embossed metal images for art or craft projects. Perfect for use with 36, 38, or 40 gauge metal foils and modeling tools. Can also be used with modeling or polymer clay. Durable and reusable.

NUMBER	DESCRIPTION	EACH	12/EA
A62926-0149	Aquarium 6" x 8"	\$2.03	\$1.76
A62926-0019	Bronco 4" x 4"	1.20	1.04
A62926-0099	Clown 4" x 4"	1.20	1.04
A62926-0069	Cocker Spaniel 4" x 4"	1.20	1.04
A62926-0079	Elephant 4" x 4"	1.20	1.04
A62926-0049	Horse 4" x 4"	1.20	1.04
A62926-0089	Indian Chief 4" x 4"	1.20	1.04
A62926-0109	Liberty Bell 4" x 4"	1.20	1.04
A62926-0059	Lion 4" x 4"	1.20	1.04
A62926-0169	Locomotive 6" x 8"	2.03	1.76
A62926-0129	Mallards 4" x 4"	1.20	1.04
A62926-0039	Pirate 4" x 4"	1.20	1.04
A62926-0159	Pointer 6" x 8"	2.03	1.76
A62926-0029	Praying Hands 4" x 4"	1.20	1.04
A62926-0009	Ship 4" x 4"	1.20	1.04
A62926-0119	Statue of Liberty 4" x 4"	1.20	1.04



Excel Burnishing Set

Burnishing set includes a lightweight handle and four interchangeable carbon steel tips: spoon tip, ultra-fine needle point (can be used as an awl), and two ball point tips. Use for etching, marking, scoring, and embossing on leather, paper, foils, wood, and plastic, for pattern transfer, and embossing wax or clay. Aluminum handle measures 4-1/2" long.

NUMBER	EACH	12/EA
A63995-1049	\$9.27	\$8.35



Blick Metal Punch

Easy-to-use punch makes pinpoint holes (up to 1/8") in tin or light metals, such as tooling foils. Sturdy plastic screwdriver handle. Overall length: 4-1/2".

NUMBER	EACH	24/EA	48/EA
A60510-1045	\$2.16	\$1.94	\$1.84



Modeling Tools

Use these durable double-ended tools on metal foil for repoussé or embossing.

NUMBER	DESCRIPTION	EACH	24/EA
A60500-1010	Liner	\$0.99	\$.89
A60500-1020	Modeler	.99	.89
A60500-1030	Spatula	.99	.89



Genuine Boxwood Tool Set

Genuine boxwood tools are 5-1/2" long, and are especially made for tooling metal and leather. Set includes a liner for tracing and outlining designs, a modeler with spoon and ball tips for embossing or modeling, and a spatula for flattening and smoothing.

NUMBER	EACH	12/EA
A60502-1009	\$2.30	\$2.08

Did you know we have hundreds of lesson plans designed to meet the National Standards for Visual Arts Education? See them all at DickBlick.com/lesson-plans.



Art Metal Foil Sheets

5" x 5" sheets of solid aluminum, copper, and brass. 38 gauge copper is aluminum with copper coating on one side. Packages of 12 sheets.

NUMBER	DESCRIPTION	EACH	12/EA
A60513-1036	Aluminum 36 Gauge	\$3.43	\$3.09
A60513-1136	Brass 36 Gauge	13.03	11.75
A60513-2036	Copper 36 Gauge	17.97	16.19
A60513-2038	Copper 38 Gauge	3.03	2.73
A60513-1040	Copper 40 Gauge	10.35	9.33

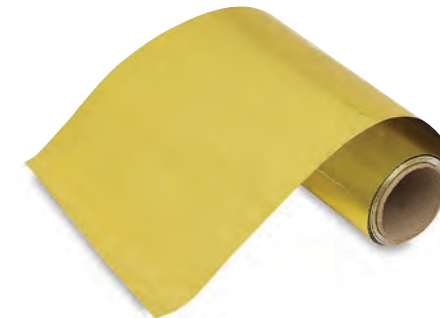

Colorfoil Economy Roll

A light gauge, easily tooled aluminum foil that is ideal for school and camp projects. Choice of coppertone or brass on one side, silver-colored on the other side. 4-1/2"W x 20 ft rolls.

NUMBER	COLOR	EACH	12/EA
A60506-8410	Brass	\$7.71	\$6.93
A60506-8110	Coppertone	7.71	6.93



Liver of Sulphur

A chemical for antiquing copper and silver, only. Changes color to darker shades from brown to black. Directions on label. 4 oz (118 ml) bottle.

NUMBER	EACH	12/EA
A60505-1004	\$6.65	\$5.98

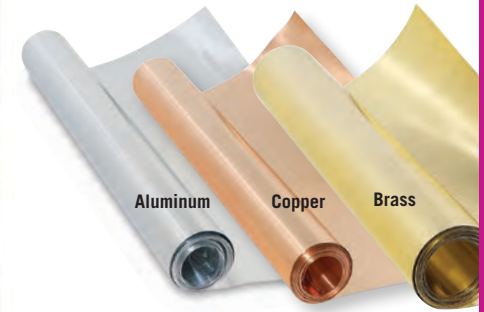

Pure Metal Tooling Foil

Make trays, plaques, planters, jewelry, wall hangings, and decorative pieces by embossing, tooling, punching, or stamping. Cuts easily with household scissors or metal snips. Copper can be antiqued to slate gray finish with liver of sulphur (sold below). 36 gauge. 12" wide.

NUMBER	METAL	LENGTH	EACH	12/EA
A60503-2750	Aluminum	10 ft Roll	\$9.48	\$8.53
A60503-2850	Aluminum	25 ft Roll	21.89	19.70
A60503-2950	Aluminum	350 ft Roll	267.85	241.06
A60503-8410	Brass	10 ft Roll	44.63	40.16
A60503-8425	Brass	25 ft Roll	109.74	98.76
A60503-8110	Copper	10 ft Roll	57.67	51.91
A60503-8125	Copper	25 ft Roll	142.52	128.26



Two-Tone Tooling Foil

Brilliant color on one side, aluminum on the other side. Perfect for 3-D work, mobiles, crafts, and tooling. 38 gauge.

NUMBER	DESCRIPTION	EACH	12/EA
A60504-8125	Coppertone	\$26.70	\$24.05
A60504-4050	Goldtone	26.70	24.05

NUMBER	DESCRIPTION	EACH
A60504-9501	Coppertone	\$353.00
A60504-9011	Goldtone	353.00



6-in-1 Texture Hammer

Six assorted heads in one hammer. Professional quality. Wood handle. 10" long.

NUMBER	EACH	6/EA
A60594-1010	\$29.49	\$26.53



Stained Glass Tiles

These tiles are cut from colored glass with rich hues that never fade. Easy to cut, nip, chip, and apply. Each tile is approximately 1/8" thick. 4 lb packages.

3/4" Square Tiles — 4 lb Assortment

NUMBER	EACH	6/EA
A60998-0004	\$42.98	\$38.68



Mosaic Mercantile Word Tiles

Perfect for mosaics and decorative crafts! These glass tiles come in bags that include a mixture of words and symbols. 4 mm thick with a smooth rounded edge. Word tiles measure 1/2" x 3/4". Symbol tiles measure 3/4" x 3/4".

NUMBER	PKG OF	EACH	12/EA
A64318-1030	30	\$6.59	\$5.93
A64318-1090	90	18.69	16.82



Mosaic Mirror Tiles

Beautiful in combination with glass tiles or as an all-over motif. Reflective mini tiles are designed for easy nipping and application. Uniform 1/8" (3 mm) thickness.

NUMBER	DESCRIPTION	EACH	12/EA
A61480-1009	Assorted Sizes, Pkg of 100	\$12.39	\$11.15



Ceramic Tiles

These 3/8" square glazed ceramic tiles have rounded corners and smooth edges, making them safe to use in any mosaic project. The 5 lb Variety Pack is an assortment of colored tiles.

NUMBER	DESCRIPTION	EACH	12/EA
A61414-1015	3/8" 5 lb Variety	\$66.75	\$60.07



Mosaic Mercantile Patchwork Tiles

Smooth, enamel-printed square pieces are intricately painted and available in a variety of colors and patterns. Measuring 3/4", they feature gently rounded corners for easy handling.

NUMBER	COLOR	EACH	6/EA
A61967-2506	Black/Grey	\$6.59	\$5.93
A61967-7246	Grass/Mint	6.59	5.93
A61967-6156	Heather Purple/Grey	6.59	5.93
A61967-4066	Lemon/Lime	6.59	5.93
A61967-5026	Light Blue/Teal	6.59	5.93
A61967-3346	Maroon/Tan	6.59	5.93
A61967-3066	Pink/Coral	6.59	5.93
A61967-5056	Royal/Ocean Blue	6.59	5.93
A61967-1003	Assorted	40.70	36.63

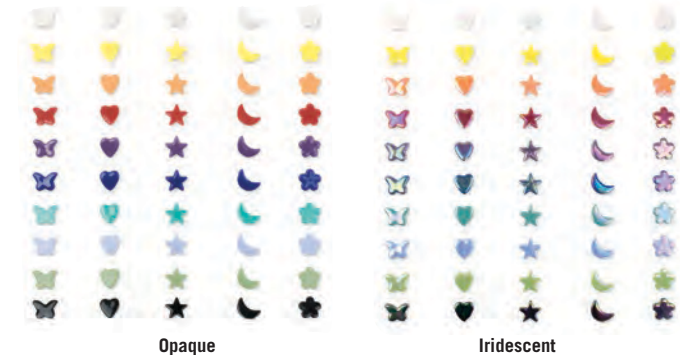

Diamond Tech Whimsy Shape Tiles

Featuring gently rounded corners, each package contains a variety of playful shapes, including stars, butterflies, hearts, crescent moons, and flowers. Tiles measure 1" x 1". Made in the USA.

NUMBER	COLOR	EACH	6/EA
A61969-1108	Opaque	\$8.64	\$7.77
A61969-1008	Iridescent	8.64	7.77



Crafter's Cut Pre-Cut Mirror Tiles

Crafter's Cut Pre-Cut Mirror Tiles come in a variety of irregular shapes for an authentic look, yet have smooth, pre-tumbled corners — no nipping or cutting required. Featuring a colored surface and reflective backing, each mirror tile allows light to pass through the top and sides for a brilliant effect. Tiles range in size between 3/4" and 3/8" wide. All are 3/16" thick. 8 oz assortment.

NUMBER	EACH	12/EA
A61912-1015	\$11.35	\$10.22



Mosaic Dots, Spots, & Squares

Add a bit of colorful fun to any indoor or outdoor mosaic project. The shiny glass rounds and squares are easy to use and provide limitless design options and versatility. Smooth edges make these tiles great for kids' crafts. This 3 lb mixed bag includes green, light blue, orange, purple, red, and yellow shapes.

NUMBER	EACH	3/EA
A61925-1003	\$35.12	\$31.61



Diamond Tech Pebbles Mixes

A variety of colors, textures, finishes, and shapes for all kinds of mosaic projects. They're safe for kids age 3 and up.

NUMBER	DESCRIPTION	WEIGHT	EACH	3/EA
A61940-5065	Royals	1.5 lb	\$33.06	\$29.75
A61940-5063	Royals	3 lb	56.21	50.59
A61940-8075	Beachside	1.5 lb	33.06	29.75
A61940-8073	Beachside	3 lb	56.21	50.59
A61940-2075	Metallics	1.5 lb	33.06	29.75
A61940-2073	Metallics	3 lb	56.21	50.59

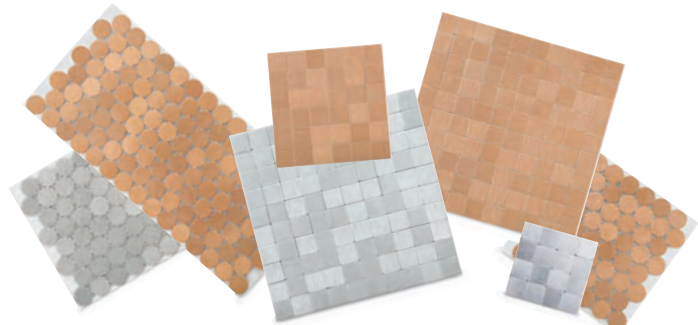

Diamond Tech Metal Tile Half Sheets

Add some edge to mixed media, décor, and craft projects. Sheets feature square or round tiles in Stainless and Rose Gold finishes. Sheets have a brushed metal finish and no sharp edges.

NUMBER	DESCRIPTION	SIZE	EACH	6/EA
A61943-1015	Stainless Squares	15 mm	\$11.12	\$9.99
A61943-1115	Rose Gold Squares	15 mm	11.12	9.99
A61943-1020	Stainless Rounds	20 mm	13.22	11.89
A61943-1120	Rose Gold Rounds	20 mm	13.22	11.89
A61943-1023	Stainless Squares	23 mm	11.12	9.99
A61943-1123	Rose Gold Squares	23 mm	11.12	9.99
A61943-1209	Bulk Mix		33.06	29.75



Classico Mosaic Tiles

These colorful, glazed glass tiles have a smooth front surface that reflects light. Rounded corners eliminate sharp edges. 3 lb bags.

NUMBER	DESCRIPTION	EACH	3/EA
A61433-1000	Classico, 3/8"	\$35.72	\$32.15
A34993-1516	Classico Minis, 5/16"	33.88	30.49



Ceramic Shapes

A 5 lb assortment of rectangles, leaves, pebbles, flowers, hearts, circles, and squares in a variety of colors. Rounded corners and smooth edges. Shapes measure approximately 3/8".

NUMBER	EACH	12/EA
A61414-1010	\$99.27	\$89.34



Mosaic Mercantile Mosaic Tool Kit

This kit contains four essential stainless steel tools, including a double-ended spatula, double-sided curved pick, fine-point short tweezers, and needle-nose cross-locking tweezers.

NUMBER	EACH	12/EA
A61929-1004	\$12.44	\$11.19



Mosaic Cobblestone Mix

Create the illusion of depth with cobblestones. Smooth, rounded edges make them perfect for all ages. Bright, radiant color lies beneath a 4 mm crystal-clear glass surface. Assortments contain a mix of irregular shapes in a variety of colors and solid and glitter finishes. Sizes range from 1/4" to 3/4".

NUMBER	DESCRIPTION	EACH	6/EA
A61920-1003	3 lb	\$41.25	\$37.10



Mosaic Coaster Kit
Contains enough materials to make 12 coasters. Includes 12, 4" reusable molds; two 2 lb tubs of fast-drying indoor mosaic cement; 100, 3/4" stained glass chips; and instructions. Can be assorted by style for quantity pricing.

NUMBER	DESCRIPTION	EACH	6/EA
A60998-0009	Square Kit	\$65.07	\$58.57

Additional Coaster Molds

NUMBER	DESCRIPTION	EACH	10/EA
A61122-0003	Square Coaster 4"	\$3.69	\$3.33



Stepping Stone Mosaic Molds

Make your own garden stepping stones with unique designs. Reusable, high-impact plastic molds have beveled edges and rounded corners to release stones easily. Mosaic chips and cement not included. Sizes can be assorted for quantity pricing.

NUMBER	DESCRIPTION	EACH	6/EA
A61122-0002	12" Square	\$16.73	\$15.05
A61122-0001	12" Round	16.73	15.05
A61122-1014	14" Round	15.96	14.37
A61122-1112	12" Hexagonal	16.73	15.05
A61122-1116	16" Hexagonal	18.53	16.68



Jennifer's Mosaics™ Outdoor Stone Cement

New stronger formula! Specially formulated for use on outdoor projects such as stepping stones, tables, benches, and more, this super strong cement stands up to the harshest weather. Results in a smooth, porcelain white finish. Requires no sealant.

NUMBER	SIZE	EACH	12/EA
A60999-0010	10 lb	\$15.76	\$14.19
A60999-0012	20 lb	28.83	25.95



Jennifer's Mosaics™ Indoor Stone Cement

This fast-drying, easy-to-mix reinforced cement is for use with indoor mosaic projects, such as furniture, boxes, frames, and coasters. Stronger and smoother than grout. Dries within one hour to a smooth, white finish.

NUMBER	SIZE	EACH	12/EA
A60999-0002	2 lb	\$8.76	\$7.88
A60999-1020	20 lb	48.21	43.39

Mosaic Adhesive

For adhering glass and ceramic mosaic tiles to wood, metal, plastic, glass, masonry, and most other surfaces. This waterbased adhesive is safe to use and dries clear. Plastic bottles.

NUMBER	SIZE	EACH	6/EA
A62948-1004	4 oz (120 ml)	\$6.94	\$6.25
A62948-1005	8 oz (237 ml)	11.62	10.45



Pre-Mixed Tile Grout

For light-duty indoor applications where space between tiles is 1/8" or less, this waterbased latex grout is pre-mixed to save time and measuring. White grout may be tinted with most acrylic paints.

NUMBER	COLOR	EACH	12/EA
A62949-2025	Black, 8 oz	\$10.37	\$9.33
A62949-1015	White, 8 oz	10.37	9.33



DIY Designs Frame Mosaic Kit

Contains everything needed to design a beautiful frame that's perfect for gifting or keeping. Frames fit photographs measuring 4" x 4". The kits also include a kickstand to ensure secure positioning, along with pre-cut, smoothly rounded tiles. For set contents, visit DickBlick.com.

NUMBER	COLOR	EACH	6/EA
A61968-2003	Black/White	\$15.39	\$13.85
A61968-5013	Blue	15.39	13.85
A61968-4923	Coral	15.39	13.85



Stepping Stone Kits

Capture a memory in stone. These DIY kits include everything you need, and the process is so simple — just mix, pour, and decorate! For details, visit DickBlick.com.

NUMBER	DESCRIPTION	EACH	6/EA
A61702-1009	Mosaic Kit	\$19.83	\$17.85
A61702-1019	Paw Print Kit	14.32	12.89



Diamond Tech® Garden Buddies

Add some cute, colorful critters to your garden. Perfect for beginners, these kits include everything you need to create mosaic butterfly, dragonfly, ladybug, gecko, snake, and snail shapes. For set contents, visit DickBlick.com.

NUMBER	SET OF	EACH	3/EA
A61942-1001	6	\$57.05	\$51.34



Woodland Mosaic Coaster Kit

This rustic kit includes 12 bark-covered wood coasters, six small bottles of glue, a 2 lb container of terra cotta-colored grout, and 3/8" ceramic tiles in assorted shapes and colors. Makes 12 coasters. Instructions included.

NUMBER	EACH	5/EA
A61728-1009	\$70.48	\$63.43



Cork Coasters Class Pack

Quality natural cork coaster rounds can be used for various art projects. Sturdy 3 mm thick. 24 per pack.

NUMBER	DIAMETER	EACH	6/EA
A61497-1004	4"	\$17.97	\$16.15
A61497-1006	6"	24.59	22.10



Milestones Mosaic Stamp Letters

These easy-to-use letters make clean impressions every time. Set includes 20 double-sided stamps with the full alphabet and all numbers, plus punctuation.

NUMBER	EACH	12/EA
A61957-1001	\$7.69	\$6.92



SuperMoss Decorative Stones

SuperMoss Decorative Stones add a natural touch to interior decorations, outdoor gardens, or special events. Use these stones in floral arrangements, potted plants, and more. 25 oz jar.

NUMBER	COLOR	EACH	12/EA
A81676-1020	White	\$7.65	\$6.88
A81676-2020	Black	7.65	6.88

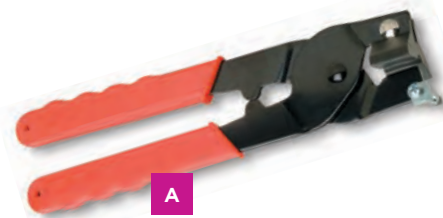

A



B



C

A-C Tile & Glass Cutters

A Scorer/Breaker — Scribes the surface of tile or glass, then makes a clean break with gentle pressure.

NUMBER	EACH	6/EA
A60997-1002	\$14.83	\$13.35

B Tile Nippers — The sharp clamp end bites down on tiles to make them smaller and to make custom shapes. Works best on ceramic.

NUMBER	EACH	6/EA
A60997-0000	\$15.96	\$14.37

C Wheeled Glass Nippers — For making more precise cuts on tiles or larger glass and ceramic pieces.

NUMBER	EACH	6/EA
A60997-1001	\$24.81	\$22.34



Safety Goggles

These comfortable safety goggles have high-quality optics and can be worn over most glasses.

NUMBER	EACH	12/EA
A61705-1001	\$5.99	\$5.36



Safety Gloves

Great for use of nipping or cutting glass pieces, these sturdy plastic gloves will keep you safe from glass chips and splinters, and keep your hands clean during grouting and gluing. Packages of 100.

NUMBER	SIZE	EACH	10/EA
A35200-1010	Small	\$18.33	\$16.50
A35200-1020	Medium	18.33	16.50
A35200-1030	Large	18.33	16.50
A35200-1040	X-Large	18.33	16.50

HEALTH & SAFETY ICONS: ●=CL / ■=Prop 65 / ▼=CL & Prop 65
See page 644 for more information.

WARNING! Products marked with a Prop 65 symbol (■ or ▼) can expose you to chemicals, including cadmium, which are known to the State of California to cause cancer and birth defects or other reproductive harm. For more information, visit P65Warnings.ca.gov.



Armour™ Etch Glass Etching Cream

Both beginners and experienced artists can now enjoy the fun of creating professional-quality, permanently etched designs on mirrors, windows, and glassware. This unique glass etching cream works in minutes — no previous experience required! Not intended for use by children.

NUMBER	SIZE	EACH	12/EA
A60966-1004	3 oz	\$10.46	\$9.41
A61176-1005	10 oz	23.92	21.53



Armour™ Etch Glass Etching Kit

Etching cream, cleaner, hobby knife, applicator, reusable plastic gloves, vinyl masking, designs, and instructions. Designs may vary.

NUMBER	EACH	12/EA
A60966-1209	\$29.32	\$26.38



Glass Craft Mirrors

These rectangular and round mirrors are ideal for jewelry boxes, dollhouses, mosaics, and other craft projects. Decorate them with customized etched designs with Armour Etch Glass Etching Cream.

NUMBER	DESCRIPTION	EACH	12/EA
A60966-1119	Rectangle, 3" x 4"	\$24.25	\$21.83
A60966-1019	Round, 3"Dia	18.07	16.26



Wall Lenk™ 100 Watt Solder Iron

This heavy-duty professional grade soldering iron uses 100 watts for a maximum tip temperature of 1035°F (557°C). It has a 3/8" wide chisel tip, and insulated heating elements. Great for stained glass and other projects.

NUMBER	EACH	6/EA
A60684-0100	\$102.85	\$92.57



Studio Pro™ Hobby 100 Soldering Iron

An economical choice for production, studio, and classroom use, this lightweight, 100W soldering iron heats up to 1000°F. The 1/4" iron chisel-style tip is ideal for standard glass projects. Features a "stay-cool" insulated comfort-grip handle. May be used with a temperature controlling device. One-year manufacturer's warranty excludes tip.

NUMBER	EACH	6/EA
A61707-1001	\$21.19	\$19.07



Soldering Paste Flux

Flux aids in the smooth flow of solder for an attractive bead. This zinc chloride paste flux is easy to use and best suited for working with copper foil. 2 oz jar.

NUMBER	EACH	6/EA
A62960-1002	\$5.22	\$4.69



Copper Foil

For all stained glass projects, this self-adhesive copper foil attaches immediately and firmly to the edges and corners of the glass, regardless of its shape. Exceptional resistance to temperature and weathering. 36 yard roll.

NUMBER	WIDTH	EACH	6/EA
A60514-1014	1/4"	\$9.71	\$8.73
A60514-1038	3/8"	13.39	12.03



Generation Green (g2) Bottle Cutter

Score and separate discarded bottles and wide-mouth jars in three simple steps! Ideal for refashioning old glass into sculptures, vases, lamp shades, votive holders, or anything else you can imagine. Made from strong, lightweight recycled aluminum with six turreted cutting heads for durability.

NUMBER	EACH	6/EA
A63828-7010	\$28.12	\$25.31



Bright Colors Earth Tones Primary Colors

Milestones Mosaic Tiles

Create colorful stained-glass frames, stepping stones, mirrors, vases, and more. Each 20 oz pack includes stained glass pieces in a variety of unique colors, shapes, and sizes.

NUMBER	COLOR	EACH	6/EA
A61958-1001	Bright Colors	\$12.09	\$10.88
A61958-1002	Earth Tones	12.09	10.88
A61958-1003	Primary Colors	12.09	10.88

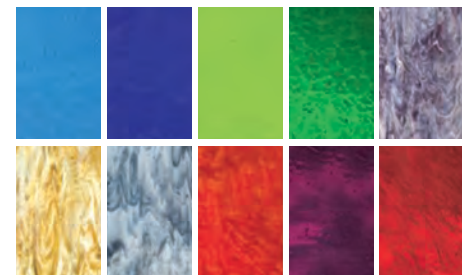

Stained Glass Class Packs

Create beautiful stained glass in the classroom. These bright, colorful 12" x 12" glass sheets are easy for beginners to cut. A variety of glass colors and styles enhance any project. Packages contain 10 sheets — a total of 10 sq ft.

Colorful Cathedral Pack — A rainbow of translucent sheets that are smooth on top and have a light texture on the back.

NUMBER	EACH	4/EA
A61430-1010	\$118.78	\$106.90



Stained Glass Class Kit

The most complete tool kit for the budding stained glass artist. Includes 2 oz flux paste, a flux brush, 1" running pliers, a 3/8" breaker/grozer, a steel wheel glass cutter, 1 lb 60/40 solder, an 80W solder iron, 1/4" copper foil, a scythe stone, and the book Memories in Glass.

NUMBER	EACH	6/EA
A62966-1009	\$128.95	\$116.05



Stained Glass Scythe Stone

An inexpensive, manual alternative to a glass grinder, this 9-3/4" long stone can be used to file the sharp or slightly rough edges of cut glass pieces to create a smooth edge for foiling.

NUMBER	EACH	6/EA
A61911-1001	\$16.79	\$15.11



Power Max II™ Glass Grinder

Surpasses all other router grinders feature-for-feature, at a price that can't be beat! The most powerful grinder ever, it has a 1/8 HP motor, a 9-1/2" x 9-1/2" easy-glide work surface, 1/4" and 1" long-lasting chrome-hardened Silver Bullet Bits, two custom-fit sponge holders, an advanced Super Sponge water cooling system, and a full six-year warranty.

NUMBER	EACH
A35109-1001	\$184.86

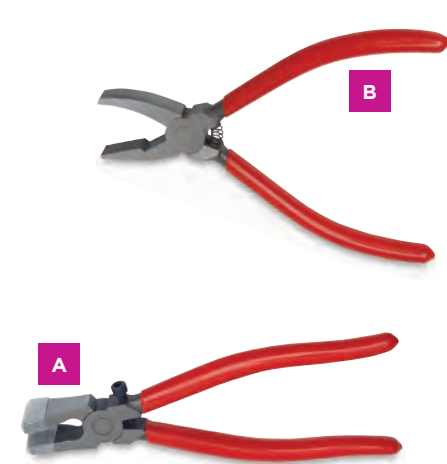

A Studio Pro™ 1" Running Pliers

Apply this tool to your score mark and break your glass apart with ease — just position the jaws at the end of the score line and squeeze. The curved jaw exerts equal pressure on each side of the score until it breaks cleanly. Use the convenient centering mark for perfect breaks every time. Lifetime manufacturer's warranty.

NUMBER	EACH	6/EA
A61708-1001	\$13.30	\$11.97

B Breaker/Grozer Pliers — Breaks glass along score lines, and nibbles glass away from edges.

NUMBER	EACH	3/EA
A61709-1038	\$11.30	\$10.16



Studio Pro™ Glass Cutter

Engineered for cutting without oil, this sturdy, general-purpose glass cutter has a traditional cast-iron handle for comfort and control.

NUMBER	EACH	6/EA
A61434-1000	\$5.53	\$4.98



Fuseworks™ Beginner's Fusing Kit

Learn to fuse stunning glass projects right in your microwave with this all-inclusive kit. Includes a Fuseworks microwave kiln, kiln paper, seven pieces of COE 90 fusible glass, 1 oz of dichroic bits and pieces, 1 oz of frit, 1/2 oz of stringers, 1 oz of variety bits and pieces, a glass cutter, hot mitts, large and small jewelry baits, two earring sets, and instructions. For complete set contents, visit DickBlick.com.

NUMBER	EACH
A61907-1009	\$159.17



Glass Bead Making Kit

Glass bead making, or lampwork, has been popular for thousands of years. This kit provides almost everything you need to begin designing and making your own beautiful glass beads. In this kit are glass rods, torch head, mandrels, pre-mixed bead separator, heat pad, fiber blanket, bead rake, grooved marver, wholly roller, clamp (for gas cylinder, not included), and detailed instructions.

NUMBER	EACH	6/EA
A61155-1009	\$178.57	\$160.72

Glass Replacement Rods — Slow melting. Approximately 1 ft long x 3/16"Dia each.

NUMBER	DESCRIPTION	EACH	6/EA
A61155-1020	Asst. Colors 15-pack	\$22.56	\$20.30
A61155-2050	Black Rods 12-pack	19.97	17.97
A61155-1010	Clear Rods 12-pack	19.97	17.97
A61155-1040	White Rods 12-pack	16.20	14.58



Logan Glass Cutter Elite

This hand-held glass cutting tool features a hardened steel wheel and an ergonomic handle. It works with any Logan mat cutters where the cutting heads hook on. Cutting fluid is included.

NUMBER	EACH
A17123-1001	\$28.34



Fuseworks™ Fusible Glass Sheets

Use these glass sheets with mosaic chunks and stringers to create original works of art. They work perfectly with glass slump molds in standard kilns and they're easy to cut for use in Fuseworks microwave kilns. COE 90 compatible. Made in the USA.

Square — 3" x 3"			
NUMBER	COLOR	EACH	12/EA
A34802-1033	Clear	\$4.41	\$3.97
Square — 6" x 6"			
NUMBER	COLOR	EACH	12/EA
A34804-2026	Black	\$12.53	\$11.27
A34804-1066	Clear	10.99	9.92
A34804-5026	Light Blue	12.53	11.27
A34804-1026	White	10.99	9.92

Glass Sheet Packs			
NUMBER	DESCRIPTION	EACH	6/EA
A34812-1033	3" x 3" Assorted Colors, 7 Sheets	\$31.51	\$28.36
A34812-1166	6" x 6" Clear, 6 Sheets	64.28	57.85
A34812-1066	6" x 6" Assorted Colors, 6 Sheets	77.53	69.78



6" Flat Sides

6" Rounded Sides

Fuseworks™ Glass Slump Molds

Compose glass designs into functional pieces of art using assorted glass shapes and colors with these plaster slump molds. Compose a design on a square or circular piece of glass using assorted glass pieces, then fuse the design on a flat kiln-washed shelf, and slump it on the mold. Made in the USA.

NUMBER	DESCRIPTION	SIZE	EACH	6/EA
A34830-1001	Rounded Sides	3" x 3"	\$22.77	\$20.49
A34830-1003	Rounded Sides	6" x 6"	34.20	30.78
A34830-1101	Flat Sides	3" x 3"	22.77	20.49
A34830-1103	Flat Sides	6" x 6"	34.20	30.78
A34830-1207	Circular	7"	34.20	30.78



Fuseworks™ Fiber Shelf Paper

Ideal for use as a smooth separator when fusing glass on a flat kiln shelf, Fuseworks Fiber Shelf Paper can be cut to fit any size or shape. It withstands temperatures up to 2300°F (1260°C). At temperatures above 1800°F (982°C), it transforms to crystalline silica, so the use of a respiratory mask is recommended during use.

NUMBER	SIZE	EACH	6/EA
A30283-1002	24" x 24" x 1/8"	\$28.54	\$25.69
A30283-1001	24" x 24" x 1/4"	30.51	27.46



Fuseworks™ Casting Glass Clear Billet Chunks

These clear, lead-free, COE 90-compatible chunks are ideal for casting small projects. Mix them with colored glass mosaic chunks and frits for a variety of unique effects. To ensure successful results, use materials with the same Coefficient of Expansion (COE). Choose the 1-1/2 lb bag for smaller chunks. Made in the USA.

NUMBER	DESCRIPTION	WEIGHT	EACH	6/EA
A34837-1001	Small to Medium Frit	1-1/2 lb	\$36.36	\$32.73



Fuseworks™ Microwave Glass Kiln

A simple and inexpensive way to begin glass fusing. Kiln fits in standard microwave ovens and fuses small pieces in 3–4 minutes. Exterior dimensions are 3-1/4"H x 4-1/2"Dia, with an interior fusing platform measuring 2-3/4". Use only with microwaveable glass.

NUMBER	EACH	6/EA
A63108-1001	\$133.47	\$120.13



Approx. 3/8" diameter

Approx. 1" diameter

Glass Globes

Assorted bright colors of transparent glass. Free-form round shapes are flat on one side, approximately 1/8" thick. 1 lb bag.

NUMBER	DESCRIPTION	EACH	12/EA
A34924-1106	■ Approx. 3/8" diameter	\$6.75	\$6.07
A34924-1006	■ Approx. 1" diameter	\$6.75	\$6.07

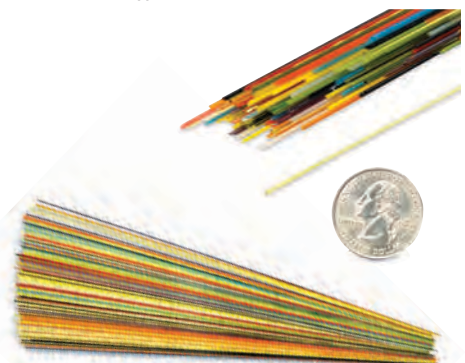

Fuseworks™ Glass Stringers

Fuseworks Glass Stringers are great for lines, patterns, and intricate embellishments on larger glass pieces. They can be used on or between other glass pieces. 5 oz bag contains a variety of beautiful colors. Stringers measure 17" long. All are COE 90. Made in the USA.

NUMBER	EACH	12/EA
A34807-1005	\$55.10	\$49.59



Fuseworks™ Craft Kiln

Getting started in glass fusing, enamels, or ceramics has never been easier. The Fuseworks Craft Kiln is a beginner/intermediate-level kiln with an adjustable electronic timer that allows the full fusing of glass or firing of enamels and some ceramics in less than an hour. Ceramics are limited to low-fire glazing on pre-fired bisque. Includes kiln, stand, and instruction manual. Features include a large 8-1/2"Dia x 3-3/5"D firing chamber, a self-regulated coil heating system, a heat-resistant wood handle, and a user-friendly timer. Operates on standard voltage.

NUMBER	EACH	6/EA
A30288-1083	\$274.48	

HEALTH & SAFETY ICONS: ●=CL / ■=Prop 65 / ▼=CL & Prop 65
See page 644 for more information.



Skutt FireBox 14 Kiln

The perfect kiln for fusing glass tiles, with a square chamber that holds a full sq ft of 4" x 4" tile. Top-fired design heats each tile uniformly. Three-button controller has programming features for beginning or advanced artists. Wood handle stays cool. Accessory kit includes 13" x 14" shelf. 120V. Truck Shipment and FOB Factory. See page 648 for details.

NUMBER	DESCRIPTION	EACH
AF30185-1001	Kiln	\$1398.00
AF30185-1009	Accessory Kit	61.14



Skutt FireBox 8 Kiln with GMLT Controller

This kiln offers all the convenience features of the FireBox 8 plus the GlassMaster LT3 Button Controller, which allows users to write and store up to five programs with up to eight segments each. It also includes the exclusive Skutt Glass Fire Mode — simply choose Fuse, Tack Fuse, or Slump, pick a speed based on the size and thickness of the project, and press "start." Features include an 8" x 8" x 4-1/2" chamber, a "cool-to-the-touch" wood handle, and a stand. 120V. Includes a two-year manufacturer's warranty on parts and labor. FOB Factory. See page 648 for details.

NUMBER	EACH
AF30182-1201	\$978.00

Amaco™ Kiln Shelf Wash

Kiln Shelf Wash is used to coat and protect shelves during firing. With a 1/16" thick coating, shelf life is prolonged and glaze drippings are easy to remove.

NUMBER	SIZE	EACH	6/EA
A32922-0001	1 lb, Jar	\$7.65	\$6.89
A32922-0000	4 lb, Bag	22.50	20.25
A32922-1040	▼ 40 lb, Bag	69.95	62.95



Paragon™ QuikFire 6 Kiln

The QuikFire 6 brings instant gratification to ceramics, glass fusing, enameling, and china painting. Small glass pieces can be fired and cooled to room temperature in only 30 to 40 minutes; small ceramics may take up to 50 minutes. No more waiting to fill your larger kiln to test-fire a new technique. This kiln is a learning tool you will use over and over. The QuikFire 6 is made from a ceramic fiber shell with an embedded element. It measures 6" x 6" x 6" inside and rests on a ceramic fiber base with steel stand. Rated to 2000°F, it fires on 120V and needs no other heating source. At only 1560W, it uses less power than some hair dryers. It includes a built-in pyrometer. FOB Factory. See page 648 for details.

NUMBER	DESCRIPTION	EACH
AF30155-0120	120V	\$508.00

QuikFire 6 Furniture Kit — Contents include two shelves. FOB Factory. See page 648 for details.

NUMBER	EACH
AF30155-1009	\$52.30



torches

A-D Wall Lenk™ Pro-Torch

Adjustable, high-output flames, sturdy yet lightweight polymer bodies, and ergonomic grips make these refillable butane torches ideal for the lab, studio, or home. Internal parts are long-wearing brass and ceramic. On minimum settings the pro-quality LPT-500 delivers 200 minutes of non-stop use; the LPT-200 delivers 60 minutes. 2500° flame temperatures. Some assembly required.

NUMBER	DESCRIPTION	EACH
A60681-0200	A LPT-200	\$44.08
A60681-0500	B LPT-500	82.67

Refill — An economical, quality butane fuel for refillable butane torches and lighters. 1.5 oz (44 ml) bottle must ship ground.

NUMBER	EACH	12/EA
A60681-1015	\$5.05	\$4.55

C Bella Tavola™ Mini Torch Combo Pack

This "Instant On," never-failing Mini Torch is a must for every household. It takes the place of matches and, unlike spark lighters, has a windproof, waterproof ignition system that produces a perfect, jet-blue flame every time. The Combo Pack includes a 5" long Mini Torch and a 1.50 oz can of professional grade, non-clogging, triple-filtered butane fuel. Complies with childproof safety laws. Black case. For more colors, visit DickBlick.com.

NUMBER	EACH
A34349-2020	\$27.72

D Master™ Microtorches

These professional-quality, butane-powered microtorches feature built-in, refillable tanks, a slide lock that prevents accidental ignition, and a self-igniting switch that meets the safety requirements of the Consumer Products Safety Commission. The MT-51 features a non-slip grip, ideal for soldering and desoldering, for use as a pinpoint torch, for terminating specialty connectors, and for hobby and jewelry work. Operates for 120 minutes on a full charge. An included butane canister provides three fuel refills. Weighs 5 oz. Measures 6"H x 3"W x 0.3"D.

NUMBER	DESCRIPTION	EACH
A35102-1002	MT-51 Microtorch	\$31.95

WARNING! Products marked with a Prop 65 symbol (■ or ▼) can expose you to chemicals, including cadmium, which are known to the State of California to cause cancer and birth defects or other reproductive harm. For more information, visit P65Warnings.ca.gov.



3Doodler Start 3D Printing Pen EDU Learning Packs

3Doodler Start EDU Learning Packs drive student comprehension and engagement in critical STEAM subjects. Designed for grades K-8, students thrive when they experience what it's like to use their hands and minds as they bring their ideas to life in 3D! The Half Bundle includes six 3Doodler Create 3D pens, six Create DoodlePads, two Nozzle Sets, one JetPack, one project book, three user manuals, three user guides, and 600 plastic strands, plus one USB stick, 12 stickers, three unblocking tools, three nozzle remover tools, six screwdrivers, and six power adapters. For Full Bundle contents, visit DickBlick.com.

NUMBER	DESCRIPTION	EACH
A21029-1001	Set of 6	\$385.00
A21029-1002	Set of 12	660.00

Master' EC-200 Heat Gun

Ideal for heating or drying a wide variety of materials, bending plastics, shrink-wrapping, removing decals, spot-drying, and much more, this lightweight 1200W heat gun has a durable thermoplastic housing and a three-wire grounded cordset for maximum user safety. A three-position slide switch controls the fan speed in Off-Low-High modes, and a variable temperature dial adjusts the temperature between 110°F and 930°F.

NUMBER	EACH
A35102-1004	\$55.99



Dremel' Electric Engraver

Make permanent marks on any material — glass, aluminum, steel, brass, copper, plastic, pewter, and more. This lightweight (7 oz) engraver features a solid carbide engraving point and a powerful motor designed for trouble-free use, encased in a nylon housing. Plastic storage case.

NUMBER	EACH
A35002-0000	\$27.55



Fiskars' Precision Hand Drill

Fits securely and comfortably in the palm of your hand. Includes four easily interchangeable drill bits: 3/32", 1/8", 5/32", and 3/16". Perfect for craftspersons, students, or teachers.

NUMBER	EACH
A35101-0000	\$27.03

Worbla's Black Art

A companion product to Worbla's Finest Art, this black thermoplastic material has a smoother texture, with less adhesive and slightly less stretch. With a texture much like clay, fruit leather, or beeswax when heated, it takes fine details and fine filigree work well, becoming rigid and stable when cool. It can be built up in layers, shaped over forms of foam, foil, wire or similar armatures, or used as a single layer. It can be painted with virtually any paint, wax, or finish, and is often used for projects that require a more metallic finish, as its smoother surface requires less priming before metallic paint can be applied. Non-toxic, skin-safe, and requires no special equipment.

NUMBER	DESCRIPTION	SIZE	EACH
A61937-1701	Sample	14-1/2" x 9-4/5"	\$26.20
A61937-1601	Medium	29-1/2" x 19-1/2"	41.49
A61937-1501	Jumbo	39-1/4" x 59"	109.18



SKS Props' HD-Foam

Ideal for beginners and professionals who create props and costumes for cosplay and theatre, this sturdy EVA material with a smooth surface on both sides is easy to cut with scissors and utility knives, shape with heat, and sand, prime, or paint. This extremely lightweight material is great for crafting, props, and costumes that are worn for long periods of time, and its light gray color is perfect for tracing with pens and markers. It works well with CA glue, super glue, hot glue, and contact cement adhesives.

Rolls, 24"W x 60"L

NUMBER	THICKNESS	EACH	20/EA
A84900-1002	2 mm	\$11.54	\$10.38
A84900-1006	6 mm	16.16	14.54
A84900-1010	10 mm	21.93	19.74

36" Long Dowels, 2-packs

NUMBER	DESCRIPTION	THICKNESS	EACH	10/EA
A34842-1110	Half Round	10 mm	\$8.07	\$7.27
A34842-1115	Half Round	15 mm	9.23	8.31
A34842-1120	Half Round	20 mm	10.38	9.35
A34842-1210	Round	10 mm	8.07	7.27
A34842-1215	Round	15 mm	9.23	8.31
A34842-1220	Round	20 mm	10.38	9.35
A34842-1010	Triangle	10 mm	8.07	7.27
A34842-1015	Triangle	15 mm	9.23	8.31
A34842-1020	Triangle	20 mm	10.38	9.35

Lightweight Foam Clay — Add details to costumes and props by pressing this clay into a mold or sculpting it by hand. Can be cut, sanded, glued, primed, and painted. Air-dries within 24–48 hours.

NUMBER	SIZE	EACH	10/EA
A34384-1003	300 g	\$20.78	\$18.70



Worbla's Finest Art

A favorite for cosplay and classroom use, with the quickest and easiest learning curve, Worbla's Finest Art is brown in color with an orange peel-like texture. It's non-toxic, skin-safe, and can be shaped by hand without special safety equipment to form rigid, strong pieces. When heated with a heat gun, hot air, water, an iron, or steam, it takes complex curves without requiring a vacuum, and is self-adhesive when activated — meaning that glues are not required to join the pieces. It can be painted with just about any paint, wax, or finish after priming.

NUMBER	SIZE	EACH
A61938-1601	14-1/2" x 9-4/5"	\$23.16
A61938-1501	29-1/2" x 19-1/2"	37.25
A61938-1401	39-1/4" x 59"	97.70



A Smooth-On' ReoFlex' 30 Urethane

This easy-to-use urethane rubber provides outstanding detail down to a fingerprint. For a variety of applications: making molds; reproducing sculpture and architectural elements; and making special effects, toys, and prototypes. Meets the stringent demands of production casting of wax, plasters, concrete, and resins. Can be color-tinted. 1:1 mix by volume. 2 lb.

NUMBER	EACH	4/EA
A33561-1550	\$30.25	\$27.22

B Smooth-On' Oomoo' Silicone Rubber

This easy-to-use silicone rubber is perfect for first-time silicone users who don't have specialized mold-making equipment. Good for making simple one-piece or two-piece block molds, its low viscosity assures easy mixing and pouring, and makes vacuum degassing unnecessary. Cures at room temperature with negligible shrinkage. Convenient 1:1 by volume mix ratios — no scale necessary. 2.8 lb.

Oomoo 25 — A faster version, with a 15-minute pot life and a 75-minute cure time. Soft 25A Shore hardness.

NUMBER	EACH	12/EA
A33524-9025	\$34.97	\$31.48

Oomoo 30 — A slightly harder version, with a 30A Shore hardness, 30-minute pot life, and a six-hour cure time.

NUMBER	EACH	12/EA
A33562-6040	\$30.04	\$27.04



For how to make this project, visit DickBlick.com/products/smooth-on-dragon-skin-fx-pro/#videos

Smooth-On' Dragon Skin FX-Pro

A soft, stable, high-performance platinum silicone rubber designed for creating makeup appliances and skin effects. Compatible with Smooth-On Skin Tite silicone adhesive as well as medical-grade pressure-sensitive adhesives — ideal for temporarily attaching silicone appliances to the skin. Soft and stretchy, with a Shore hardness of 2A, a low viscosity, and a long working time (10–12 minutes). Cures within 45 minutes. Add Smooth-On Silc Pig pigments for an infinite array of color effects. 2 lb package includes 1 lb each of Part A and Part B, which should be mixed in a 1:1 ratio.

NUMBER	EACH	6/EA
A61934-1001	\$45.57	\$40.99



Smooth-On' Rebound 25 Silicone Rubber

A self-thickening, platinum-cure silicone for making brush-on molds. Apply with a brush or spatula — it holds onto vertical surfaces without sagging. Quick cures to a soft, flexible rubber with negligible shrinkage. Four thin layers yield a stretchy, strong, and durable mold for casting wax, gypsum, concrete, low-temperature melt metal alloys, or resins. One-to-one mix ratio by volume. Warning: Not for use in making molds of models containing sulfur, e.g., sulfur-bearing clays. Package of two 16 oz (473 ml) jars.

NUMBER	EACH	12/EA
A33586-1009	\$45.57	\$41.03

Smooth-On' Smooth-Cast' 300
Exceptionally hard white liquid plastic casting compound for fine detail.

Yield virtually bubble-free castings in 7–10 minutes with this ultra-low-viscosity casting resin. Easy to mix and pour, with a 1:1 mix ratio, it readily accepts fillers and can be pigmented. It is superior for cold cast metal applications that are tough, durable, paintable, and resist moisture and mild solvents. Use Smooth-Cast 300 for reproducing small to medium-size sculptures, cold cast bronze, making prototype models, special effects props, decorative jewelry, and more. Two 16 oz (473 ml) jars.

NUMBER	EACH	12/EA
A33524-2009	\$29.93	\$26.94

Smooth-On' Ease Release' 200 Spray

Ease Release is an excellent general-purpose release agent for making molds and casting parts. It provides excellent release and precise duplications of mold details. Use it with aluminum, chrome, platinum silicone, epoxy, rubber, and steel molds. 14 oz (414 ml) aerosol can.

NUMBER	EACH	12/EA
A33551-1012	\$16.58	\$14.92



Smooth-On' Ecoflex'

This versatile, platinum-catalyzed silicone is easy to use for cosplay, special effects (especially in animatronics), and prosthetic appliances and orthotic/orthopedic devices. Certified skin-safe, both varieties cure at room temperature with a minimum of shrinkage. The cured rubber is very soft, strong, and stretchy. Can be color-pigmented with Smooth-On Silc Pig silicone color pigments. For details, visit DickBlick.com.

NUMBER	DESCRIPTION	EACH
A61944-1001	Ecoflex 00-30	\$41.88
A61944-1002	Ecoflex 00-35 Fast	41.88



Smooth-On' Starter Kit

Welcome to the world of mold making and casting! This pourable starter kit gives you step-by-step print and video instructions, plus all the materials you need to get started. Great for artists, inventors, candle makers, arts and crafts enthusiasts, and resin jewelry makers. For contents, visit DickBlick.com.

NUMBER	EACH	6/EA
A34106-1009	\$60.44	\$54.40



C Smooth-On' Mold Star' 16 Fast

This easy-to-use platinum silicone rubber requires no weighing scale. Ideal for casting wax, gypsum, resins, concrete, and more, it has a relatively low viscosity, a six-minute pot life, a 30-minute cure time, and cures to a soft, strong rubber that is tear-resistant, long-lasting, and has very low shrinkage. Vacuum degassing is not required for most applications. Cured molds are heat-resistant up to 450°F, suitable for casting low-temperature melt metal alloys. Not intended for brush-on moldmaking.

NUMBER	EACH
A61935-1001	\$45.14

D Smooth-On' Skin Tite' Bio-Adhesive

This skin-safe silicone can be sculpted on the fly for creating fast wounds, scars, slash wounds, and more. Skin Tite can also be used as a bio-adhesive, to adhere skin effects, silicone appliances, or silicone masks. The cured rubber is strong and flexes with body movements. Use with Smooth-On Silc Pig to create a variety of color effects and hyper-realistic cuts, scars, bruises, bullet holes, and more. 2 lb package.

NUMBER	EACH
A61939-1002	\$54.62



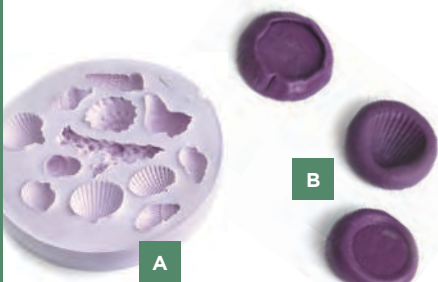

A Easy Mold[®] 1:1 RTV Silicone Putty
Strong, flexible, food-grade material for molding plaster, concrete, wax, soap, low-melt metal, baking, chocolate, ice cubes, air-dry clay, and resins. Three-minute work time; 20-minute cure time. Excellent for picking up small details. No shrinkage after curing. Self-releasing. Can be heated up to 400°F.

NUMBER	DESCRIPTION	EACH	6/EA
A34109-1059	1/2 lb Kit	\$23.64	\$21.25
A34109-1019	1 lb Kit	39.57	35.62

B Easy Mold[®] 1:1 RTV Silicone Rubber
Strong, flexible, food-grade mold-making material for plaster, concrete, wax, soap, low-melt metal, baking, chocolate, ice cubes, air-dry clay, and resins. One-hour work time; 24-hour cure time. Excellent for picking up small details. Self-releasing; will not shrink. Can be heated up to 400°F.

NUMBER	DESCRIPTION	EACH	6/EA
A34109-2019	1 lb Kit	\$59.29	\$53.36



Amaco[®] Flexwax Reusable Moldmaking Material

A wax-plastic material for making molds quickly, easily, and inexpensively. Simply melt it, then brush it on or dip the object into it. Flexwax melts at 120°F, a comfortably warm temperature. It cools in a few minutes to form a tough, flexible mold. Reproduces fine detail. Safe and harmless to the skin. May be remelted and reused. Complete instructions are included.

NUMBER	SIZE	EACH	12/EA
A33504-1905	5 lb Block	\$81.50	\$73.35



Amaco[®] Rubber Latex

A white, liquid rubber latex material for applying in layers over original models to prepare them for castings made of plaster of Paris. Finished molds are tough and flexible. Note: Latex cannot be shipped in freezing weather.

NUMBER	SIZE	EACH
A34120-1006	● Pint (473 ml)	\$30.99

Castin'Craft[™] Clear Polyester Casting Resin

The versatility, lightness, and affordability of polyester resin has increased in popularity as a material for making jewelry, paperweights, and other decorative items. When mixed with a hardening catalyst, this casting resin forms a glass-like coating, making it easy to encapsulate found or textured objects. Finished pieces can be painted and textured to resemble ivory, horn, bakelite, or amber. Includes a bottle of catalyst, which can be stored in the resin container's bubble-top cap.

NUMBER	SIZE	EACH	12/EA
A33520-1017	■ Pint (473 ml)	\$32.27	\$29.03
A33520-1016	■ Quart (946 ml)	45.09	40.58
A33520-1019	■ Gallon (3.78 Liter)	123.60	111.23

Castin'Craft[™] EasyCast Clear Casting Epoxy

This two-component clear casting epoxy is low odor and solvent-free. For casting small decorative items and jewelry in molds. Color with Castin'Craft opaque pigments for solid colors, or transparent dyes for the look of colored glass.

NUMBER	SIZE	EACH	12/EA
A33520-1105	■ 8 oz (237 ml)	\$16.85	\$15.16
A33520-1109	■ 16 oz (473 ml)	27.88	25.08



Castin'Craft[™] Transparent Dyes

These universal transparent dyes are for use with Castin'Craft Clear Polyester Casting Resin and EasyCast Clear Casting Epoxy. 1 oz (30 ml) containers with drop dispenser.

NUMBER	COLOR	EACH	6/EA
A33589-4911	■ Amber	\$8.51	\$7.66
A33589-5011	■ Blue	8.51	7.66
A33589-7011	■ Green	8.51	7.66
A33589-3011	■ Red	8.51	7.66
A33589-4011	■ Yellow	8.51	7.66

Castin'Craft[™] Mold Release and Conditioner

All molds require mold release when casting with EasyCast Epoxy or Clear Polyester Casting Resin. Use this product as a release agent and to clean, condition, and extend the life of your molds. Odorless and solvent-free. Convenient 4 oz (120 ml) spray bottle.

NUMBER	SIZE	EACH	12/EA
A33588-1004		\$13.05	\$11.74



Pebeco[®] Gedeo Resins

These transparent resins are ideal for molding, coatings, lamination, and more. Their strength and transparency render a uniquely vitreous effect that looks like glass. Perfect for creating jewelry and pendants, or for making decorative embellishments and dimensional inclusions, they can also be used as a protective laminate or coating over art pieces. Use them on canvas, metal, wood, pictures, postcards, and more. They dry within 24 hours to a shiny, hard, non-yellowing finish.

Colour Resins — Can be mixed with each other, as well as with Gedeo Crystal Resin, to create unlimited shades and effects.

NUMBER	COLOR	EACH	12/EA
A34129-8134	■ Amber	\$20.93	\$18.84
A34129-7224	■ Jade	20.93	18.84
A34129-5264	■ Lapis Blue	20.93	18.84
A34129-3374	■ Ruby Red	20.93	18.84
A34129-4304	■ Topaz	20.93	18.84

Crystal Resin — This transparent resin may be mixed with Gedeo Colour Resins to create unlimited shades and effects.

NUMBER	SIZE	EACH	12/EA
A34129-1004	150 ml	\$20.93	\$18.84
A34129-1003	300 ml	37.20	33.48
A34129-1007	750 ml	47.52	42.76



Castin'Craft[™] Reusable Molds

Designed to work with polyester resins and epoxy, these reusable molds come in a variety of sizes and shapes. They can be used many times over when properly cared for. Use Castin'Craft Mold Release and Conditioner to clean.

NUMBER	DESCRIPTION	SIZE	EACH	12/EA
A33520-2005	Dome	3" Dia x 1-3/8"	\$7.22	\$6.50
A33520-1001	Rectangle	2" x 1-1/2" x 1"	6.35	5.71
A33520-0000	Rectangle	2-1/8" x 3-1/4" x 1-1/8"	6.35	5.71
A33520-0001	Rectangle	2-1/4" x 2-5/8" x 1-1/8"	6.35	5.71
A33520-1004	Rectangle	3" x 5" x 1-1/16"	7.22	6.50
A33520-1008	Rectangle	3" x 6" x 1-1/16"	7.22	6.50
A33520-1002	Round	2-3/8" Dia x 1-1/8"	6.35	5.71
A33520-2006	Square	3" x 3" x 1-1/16"	7.22	6.50

ArtMolds[®] KastEZ[™] Resin

Sets to a hard, lightweight white plastic. With a 1:1 mixing ratio and 30-second mix time for quick start, two-minute pot life, and 10-minute de-mold time, it's ideal for castings, from rigid to flexible molds for rapid prototypes, to sculpture reproductions and special effects. Requires release with polyurethane molds but not silicone molds (MoldRite 25).

NUMBER	SIZE	EACH	6/EA
A33563-1006	Pint (473 ml)	\$34.67	\$31.21
A33563-1007	2 Quart (1.89 Liter)	87.93	79.14
A33563-1009	2 Gallon (7.56 Liter)	270.82	243.80

ArtMolds[®] AquaClear[™] Clear Casting Resin

This polyurethane casting resin is the choice of fine artists. It's well-suited to casting fine art, encapsulating objects, reproducing sculpture and giftware, and producing rapid prototypes. It is UV-resistant, resists yellowing, and tends not to trap air bubbles. Unlike polyester resins (which are extremely toxic and require the use of a NIOSH mask), AquaClear has little or no odor. Sets in 15–20 minutes.

NUMBER	SIZE	EACH	6/EA
A33564-1006	Pint (473 ml)	\$54.34	\$48.91
A33564-1007	2 Quart Kit (1.89 Liter)	161.99	145.80
A33564-1009	2 Gallon Kit (7.56 Liter)	538.00	485.00

ArtMolds[®] CastRite[™]

This bright white gypsum casting stone is an ideal cast-making material or shell mold medium. It's easy to work with, stronger than Plaster of Paris, and provides greater detail. It accepts paints and other finishes, and may be sanded by hand or with power tools after drying. Its porosity ensures excellent slip castings. The mold material of choice with 407 Latex Casting Rubber. Sets in two hours. 10 lb.

NUMBER	SIZE	EACH	4/EA
A33581-1010		\$28.61	\$25.75



Castin'Craft[™] EasyCast Resin Jewelry Molds

Made from smooth, durable polypropylene, Castin'Craft EasyCast Resin Jewelry Molds are great for making resin jewelry in a variety of popular shapes. They can be used over and over again when cared for properly. For more information, visit DickBlick.com.

NUMBER	DESCRIPTION	EACH	6/EA
A61945-1002	8 Shapes	\$6.35	
A61945-1001	11 Shapes	6.35	



ArtMolds[®] Alginates

You'll have peace of mind when using Hollywood Impressions and MoldGel SloSet alginates: they contain no silica, fluoride, or dust and are made of healthy, food-grade ingredients. They're a "green," environmentally friendly choice for making molds, body casts, and creating special effects pieces. FiberGel sets in 4–5 minutes, Hollywood Impressions sets in 2–3 minute, MoldGel Regular sets in 3–5 minutes, and MoldGel SloSet sets in 7–8 minutes. Made of dental-grade ingredients, its duo fiber matrix formula gives it high tear- and shrink-resistance. 1 lb; additional sizes available on DickBlick.com.

NUMBER	DESCRIPTION	EACH	6/EA
A33567-1001	FiberGel 1 lb	\$23.09	\$20.78
A33579-1001	Hollywood Impressions 1 lb	19.61	17.65
A33566-1001	MoldGel Regular Set 1 lb	19.61	17.65
A33566-2001	MoldGel SloSet 1 lb	19.61	17.65

ArtMolds[®] Moldez[™] Skin & Mold Release

Use this waterbased release cream instead of petroleum jelly on the skin and all body hair. Washes off the first time, unlike petroleum-based jellies. Work a generous amount into the hair and then comb. You can cast an entire head of hair. Also great to fill pin holes in your MoldGel and alginate molds prior to casting. 8 oz (236 ml).

NUMBER	SIZE	EACH	6/EA
A33574-1008		\$18.47	\$16.62



Make-a-Mold Casting Kits

The winner "hands down" for casting one statue of any size hands in perfect detail, in a variety of different poses. Kit contains a 7-3/4"H x 5"Dia molding container, molding powder, and casting plaster. The class pack makes up to 10 statues.

NUMBER	DESCRIPTION	EACH	6/EA
A33534-2009	■ 10 Kits Class pack	\$101.41	\$91.28
A33534-1009	■ Hands	16.53	14.87



ArtMolds[®] KreemTex[™] Latex

This high-quality, easy-to-use, white latex mold-making compound contains the highest concentration of latex solids for better coverage. Commonly used for statuary, concrete, plaster, and wax, it forms a soft, flexible rubber film and will reproduce intricate surfaces in exact detail. It has a long life for repeated castings, ages well, and has excellent stability in storage.

NUMBER	SIZE	EACH	6/EA
A33576-1006	Pint (473 ml)	\$32.47	\$29.22
A33576-1009	Gallon (3.78 Liter)	133.35	119.99

ArtMolds[®] 407 Latex Casting Rubber

This premium casting rubber can be used for making high-quality masks and body parts, or as a skin over polyurethane foams. Noted for its very good consistency, it may be thinned with water if needed. To create a quick mold, submerge or dip the model to be cast three to four times to achieve required thickness. Molds may be trimmed, sanded, or painted. Sets in 12 hours.

NUMBER	SIZE	EACH	6/EA
A33575-1006	Pint (473 ml)	\$32.47	\$29.22
A33575-1009	Gallon (3.78 Liter)	133.35	119.99

ArtMolds[®] LifeRite[™] Skin Safe Silicone

This is a skin-safe, two-component, room temperature cure molding rubber, most often used for life and body casting because of its excellent detail and long mold life. Commonly used for polyester, epoxy, polyurethane, masonry, gypsum, and wax casting. No release agents required. Sets in 8–10 minutes.

NUMBER	SIZE	EACH	6/EA
A33572-1006	Pint (473 ml)	\$63.71	\$57.34
A33572-1009	Gallon (3.78 Liter)	492.00	443.00



Make-a-Mold Material

Create memories that last a lifetime! The same tough alginate impression material used by the dental industry is now available for making life castings. Completely safe, non-toxic, non-allergenic, and completely organic, it won't harm skin, so cast away on hands, feet, and other body parts or objects!

NUMBER	SIZE	EACH	12/EA
A33535-1013	■ 13 oz Bag	\$7.71	\$6.94
A33535-1045	■ 4-1/2 lb Box	36.37	32.74
A33535-1025	■ 25 lb Bag	175.28	157.80

ACTIVA[®] CELLUCLAY[®]

Step 1. Form a model using wire or tape and wrap it with Activa Rigid-Wrap. See page 484.



Step 2. Mix CelluClay and cover model completely.



Step 3. Finish project with acrylic paint and varnish.



Activa[®] CelluClay[®] Instant Papier Mâché

A finely textured, non-toxic material that handles like clay, requires no special tools, and needs no firing. Just mix with water. It adheres to almost any surface. Dried forms can be sawed, sanded, nailed, or waterproofed. Finish with any kind of paint or varnish. Dries permanently hard.

NUMBER	SIZE	EACH	10/EA
A33106-1006	1 lb Pkg	\$14.14	\$12.73
A33106-1005	5 lb Pkg	33.72	30.35
A33106-1024	24 lb Pkg	120.92	108.80

Activa[®] CelluClay II[®] Instant Papier Mâché

The ultimate WHITE papier mâché! Has all the same working properties as regular CelluClay.

NUMBER	SIZE	EACH	10/EA
A33107-1006	1 lb Pkg	\$12.12	\$10.99
A33107-1005	5 lb Pkg	36.35	33.29
A33107-1024	24 lb Pkg	122.80	111.39



Blick's[®] Mix Instant Papier Mâché

All the properties of original papier mâché but with no newspapers to cut up and no flour or wheat paste to buy. It's easy to prepare, easy to model, and dries white and very lightweight. Furnished in dry form, it mixes with water and is ready for modeling immediately. It will start to set up in about 30 minutes, at which time fine modeling and smoothing of the surface is easily achieved. When dry, Blick's Mix sculptures may be sanded, sawed, drilled, and decorated with any type of paint. Shake bag before opening to thoroughly mix, as some settling may occur in shipping.

NUMBER	SIZE	EACH	6/EA
A33102-1005	5 lb Bag	\$37.69	\$33.93
A33102-1020	20 lb Bag	124.60	112.20



Jovi[®] Patmâché

A less messy alternative to traditional papier mâché, this lightweight modeling material is easy to knead and mold. Premixed formula means no need to plan ahead or wait until you can use it — it always has the perfect consistency. Dries at room temperature within 24–48 hours. 1-1/2 lb.

NUMBER	SIZE	EACH	12/EA
A34303-1015	1.5 lb	\$10.66	\$9.60



FloraCraft[®] Foam Sculpture Head

Use to create masks or busts by applying non-hardening model clay to form facial features. Cover with plaster or other mold-making material, and remove clay for a perfect negative impression of the mask to be cast. Unlike Styrofoam, this expanded polystyrene (EPS) foam head can also be painted and glued without melting the material. The surface can also be sanded. Life-size foam head is non-toxic and 100% recyclable.

NUMBER	DESCRIPTION	SIZE	EACH	6/EA
A03166-1057	No Face	10" x 5.75" x 7"	\$5.70	\$5.14



Amaco[®] Powder Wheat Paste

Create paper mache and paper paste projects with ease. Amaco Powder Wheat Paste is easy to mix, and it's safe for artists and crafters of all ages. Wheat Paste Powder dries transparent. Paint and embellish it with most mediums, including acrylic and oil paints.

NUMBER	DESCRIPTION	EACH
A34162-1008	8 oz	\$13.40
A34162-1003	3 lb	31.66



PlayBox[™] Wheat Paste

Playbox Wheat Paste is made from real wheat and contains no preservatives. It's perfect for making papier mâché, or for any project that calls for paper paste. It mixes easily, and is non-toxic and non-staining. Shipped in a powder form, it has a long shelf life when stored dry. Only mix enough paste for the project at hand, since the wet paste will spoil if not used immediately.

NUMBER	SIZE	EACH	6/EA
A24007-1001	1 lb (454 g)	\$4.51	\$4.06
A24007-1003	3 lb (1.4 kg)	11.55	10.40



Activa[®] Fast Mâché

The fastest air-drying paper mâché available is durable, paintable, carvable, and safe for kids. Heavier, with a tougher finish than the original mâché, it's especially suited for 3-D work. Just add water. Dries bright white.

NUMBER	SIZE	EACH	6/EA
A33116-1002	1-3/4 lb	\$14.20	\$12.78
A33116-1004	4 lb	26.78	24.10
A33116-1024	24 lb	118.05	106.30



Amaco[®] Sculptamold[®]

A white, non-toxic compound that combines the best features of clay, plaster, and papier mâché. Lightweight like papier mâché, but it will not shrink. May be applied to an armature or over any core. Models and casts like clay, sets up hard like plaster in about 30 minutes. When dry, Sculptamold can be sawed, carved, or nailed. It's shatter- and break-resistant. Surfaces may be decorated with any paint. Waterproof with clear lacquer, varnish, or gloss acrylic. *Does not qualify for free shipping offer. See shipping charge exceptions on page 648 for details.

NUMBER	SIZE	EACH	6/EA
A33104-1003	3 lb Bag	\$11.52	\$10.37
A33104-1025	*25 lb Bag	68.86	61.98
A33104-1050	*50 lb Bag	112.29	101.06



Amaco[®] Claycrete[®] Instant Papier Mâché

Just mix with water, knead, and model. Pure white mâché won't stick to hands or tools, making it exceptionally easy to work with and clean up. Dries white and very lightweight. After it is thoroughly dried, it can be painted and decorated. Economical for the classroom. Works great with WireForm[®].

NUMBER	SIZE	EACH	12/EA
A33118-1001	1 lb Bag	\$11.40	\$10.26
A33118-1020	20 lb Bag	137.55	123.79



Multi-Mix Plastic Tub

This graduated plastic tub is great for mixing paints, resin, plaster, papier mâché, and more.

NUMBER	SIZE	EACH
A04810-1001	1 qt	\$1.98
A04810-1025	2-1/2 qt	3.84
A04810-1005	5 qt	6.69

PlayBox[™] Plaster of Paris

Especially formulated for arts and crafts, this premium plaster of Paris is manufactured from the highest-grade materials, yet is affordably priced to please your budget. Choose from three sizes to suit your classroom needs.

NUMBER	SIZE	EACH	6/EA
A33531-1045	4-1/2 lb	\$5.28	\$4.75
A33531-1008	8 lb	7.16	6.44
A33531-1025	25 lb	16.30	14.67

DAP[®] Plaster of Paris

Ideal for molds, casting, and hobby use, DAP Plaster of Paris features a smooth formula that provides great results every time. It sets fast, usually within 10 minutes, without shrinking. Finished works made with DAP Plaster of Paris are intended for indoor use only.

NUMBER	SIZE	EACH	6/EA
A33557-1045	4.4 lb	\$7.51	\$6.76

Activa[®] Art Plaster[™]

The workhorse of casting materials. Activa Art Plaster is engineered for a super white product that mixes easily, is carvable, casts with exceptional detail, can be used for rigid molds, and features a durable surface. Denser than Plaster of Paris with superior working qualities. Can be painted and accepts other finishes when dry. This 5 lb heavy-duty canister ensures a responsive and resealable product.

NUMBER	SIZE	EACH	4/EA
A33525-0005	5 lb	\$17.08	\$15.39

Blick[®] Pottery Plaster No. 1

For casting molds, wedging tables, and bats. Pottery Plaster is harder than Plaster of Paris, but not as hard as Densite, below. Mix water and plaster, pour into mold, and let set for 10–15 minutes. Objects can be painted or varnished.

NUMBER	SIZE	EACH	12/EA
A33536-1008	8 lb Box	\$7.74	\$6.97
A33536-1025	25 lb Box	18.06	16.26

Densite Plaster

For super-hard casts, choose densite plaster. It sets hard 15 to 20 minutes after mixing and is adaptable to the production of hard, strong, tough patterns and duplicator models. High-strength gypsum content.

NUMBER	SIZE	EACH	12/EA
A33537-1008	8 lb Bag	\$8.42	\$7.58
A33537-1025	25 lb Bag	21.48	19.33



Clay Lab for Kids[®] 52 Projects to Make, Model, and Mold With Air-Dry, Polymer, and Homemade Clay

This book focuses on kid-friendly clays that are safe and easy to use at home or in the classroom. No kiln required! Art teacher Cassie Stephens leads you through 52 fun, hands-on projects that introduce kids to a range of cognitive and manual skills. Flexibound. 144 pages. 8-1/2" x 8-1/2".

NUMBER	DESCRIPTION	EACH
A70284-1001	Clay Lab for Kids	\$26.49

Activa[®] Quick-Casting Kit

Create perfect replicas of almost any object! Ideal for creating jewelry, home décor, sculpture replicas, and 3-D hand or handprint sculptures, this kit has everything you need, including InstaMold temporary mold-making compound, PermaStone casting plaster, stir sticks, and a mixing bucket.

NUMBER	SIZE	EACH
A61947-1001	18 oz InstaMold/28 oz PermaStone	\$22.04

Amaco[®] Friendly Plastic[®] Pellets

These easy-to-use, non-toxic modeling pellets can be formed, sculpted, or pressed into molds after softening them in warm water. Great for use by schoolchildren, professional sculptors, designers, and even inventors, they heat up quickly, cool quickly, and are reusable. Try combining this material with beads, wire, yarn, or sequins, or imprint it with texture tools, rubber stamps, found objects, and more.

NUMBER	DESCRIPTION	EACH	12/EA
A63285-1044	4.4 oz Jar	\$22.17	\$19.95
A63285-1028	28 oz Jar	71.43	64.28



Blick® Plaster Cloth
Our own plaster cloth rolls of pre-shrunk cotton gauze fabric are saturated with Plaster of Paris. They're simple to use; just cut and dip strips of plaster cloth in warm water, then layer them on wire armatures, cores, and body parts. When dry, it can be sanded, painted, and sealed. Setting times may vary.

NUMBER	SIZE	WEIGHT	EACH	6/EA
A34134-1800	4" x 5 yds	6.4 oz	\$6.74	\$6.06
A34134-2500	4" x 250 yds	20 lb	93.80	84.42
A34134-2805	8" x 5 yds	15.8 oz	12.43	11.18
A34134-2825	8" x 250 yds	40 lb	180.25	162.23

Plast'r Craft® Plaster Cloth

This pre-shrunk cotton gauze is impregnated with Plaster of Paris, then pre-cut into a convenient, 6" wide, ribbon-folded strip. Cut as much as you need, dip it in warm water, and apply layers to armatures, body parts, and more. It can be painted, sanded, and sealed. The 5 lb size is 33 yds long; the 20 lb size is 132 yds long.

NUMBER	SIZE	EACH	4/EA
A33505-1005	5 lb	\$41.79	\$37.60
A33505-1020	20 lb	92.39	83.14



Activa® Rigid-Wrap Plaster Cloth

A versatile, high-quality plaster gauze product made to the specifications of artists and craftspeople. Use in sculpture, mask making, jewelry, craft projects. Even texture allows for fine detail and smooth work. Just wet it, shape it, dry it. May be microwaved, or oven- or air-dried. Accepts all finishes. When face casting, the use of a release agent such as petroleum jelly is recommended. Available in 5 yd, single-project size rolls and a 16 yd, 5 lb bulk pack.

NUMBER	SIZE	EACH	12/EA
A33507-1004	4"W x 5 yds	\$7.10	\$6.39
A33507-1008	8"W x 5 yds	13.11	11.80
A33507-1005	12"W x 16 yds	33.89	30.50
A33507-1006	6"W x 50 ft	17.18	15.47

Amaco® WireForm®

Pliable enough to mold, yet sturdy enough to add structure to clays and modeling materials, WireForm works exceptionally well as a base for clay, plaster, and papier mâché. Made from specially manufactured metals that give it incredible flexibility and strength, WireForm's unique raised diamond strands expand to form three-dimensional shapes by simply molding, crimping, twisting, expanding, and gathering. Because it can be stretched into tight contours and shapes, it is ideal for detailed projects and delicate crafts. Heavier meshes are recommended for supporting sculptures using polymer clay or casting compounds.

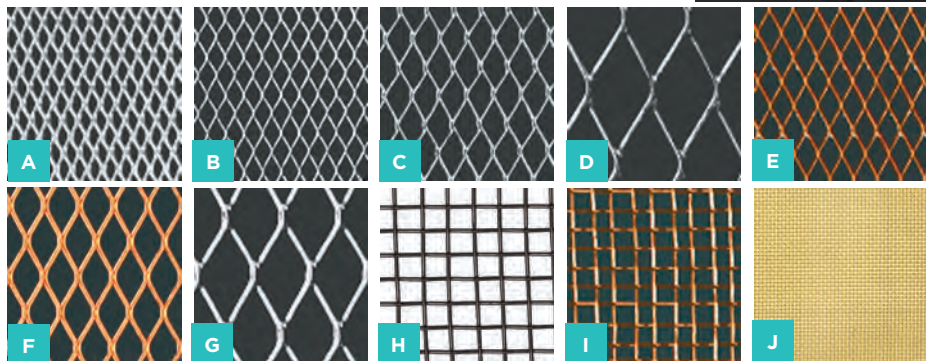

A Amaco® WireForm® Contour Mesh

Extra-fine 1/16" pattern for sculpting fine details. Aluminum.

NUMBER	SIZE	EACH	3/EA
A33408-2260	16" x 20" One Sheet, Folded	\$10.18	\$9.16
A33408-2250	16" x 20" Three Sheets, Flat	22.12	19.91
A33408-2650	20" x 10 ft Roll	43.14	38.83

B Amaco® WireForm® Sparkle Mesh

Fine 1/8" pattern for molding over solid objects and for creating art with a delicate finish. Aluminum.

NUMBER	SIZE	EACH	3/EA
A33408-2360	16" x 20" One Sheet, Folded	\$11.18	\$10.06
A33408-2350	16" x 20" Three Sheets, Flat	22.44	20.20
A33408-2750	20" x 10 ft Roll	42.95	38.66

C Amaco® WireForm® Diamond Mesh

Medium 1/4" pattern, more pliable than Sparkle Mesh. Can be layered with other mesh to create texture. Aluminum.

NUMBER	SIZE	EACH	3/EA
A33408-2460	16" x 20" One Sheet, Folded	\$12.31	\$11.08
A33408-2450	16" x 20" Three Sheets, Flat	21.25	19.13
A33408-2850	20" x 10 ft Roll	41.31	37.18

D Amaco® WireForm® Gallery Mesh

1/2" pattern ideal for baskets and vases, and for working with rigid structural modeling wire. Aluminum.

NUMBER	SIZE	EACH	3/EA
A33408-2550	16" x 20" Three Sheets, Flat	\$20.71	\$18.64
A33408-2950	20" x 10 ft Roll	43.24	38.92

E Amaco® WireForm® Impression Mesh

Fine 1/8" pattern in beautiful, glowing copper. Molds three-dimensional pieces with tight contours and detailed shapes. Copper.

NUMBER	SIZE	EACH	3/EA
A33408-1006	16" x 20" One Sheet, Folded	\$16.69	\$14.99
A33408-1005	20" x 5 ft Roll	69.65	62.68

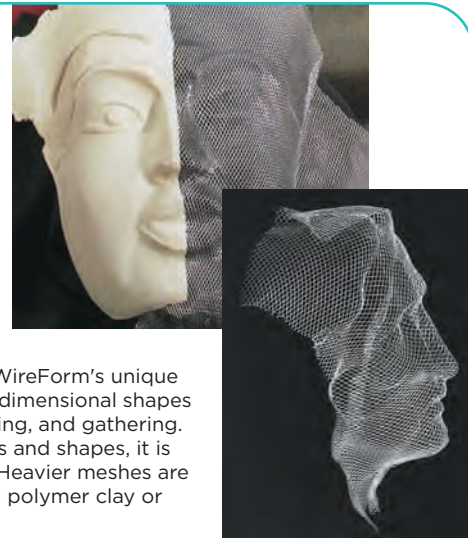

F Amaco® WireForm® CopperForm Mesh

Medium 1/4" pattern easily transforms into three-dimensional shapes by simply molding, crimping, twisting, expanding, and gathering. Copper.

NUMBER	SIZE	EACH	3/EA
A33408-8210	16" x 20" One Sheet, Folded	\$15.40	\$13.86

G Amaco® WireForm® Studio Mesh

Flexible and expandable 3/8" pattern may be stretched and shaped to create an armature or a finished sculpture. Aluminium.

NUMBER	SIZE	EACH	3/EA
A33408-1070	16" x 20" Three Sheets, Flat	\$23.92	\$21.53
A33408-1020	20" x 5 ft Roll	35.94	32.34

H Amaco® WireForm® Modeler's Mesh

Woven metal 8 mesh is flexible yet sturdy for a variety of art, craft, and model-making options.

NUMBER	SIZE	EACH	3/EA
A33408-2050	16" x 20" One Sheet, Black, Folded	\$12.69	\$11.42
A33408-2080	20" x 5 ft Roll, Black	46.69	42.03

I Amaco® WireForm® Decorative Mesh

Woven copper 8 mesh for molding over solid objects and creating delicate artwork. Similar flexibility and detail to Sparkle and Impression mesh.

NUMBER	SIZE	EACH	3/EA
A33408-7060	16" x 20" Two Sheets, Copper, Flat	\$28.72	\$25.84

J Amaco® WireMesh® Woven Wire Fabric

This woven 80 mesh looks and feels like fabric but will hold its shape. It cuts easily with scissors and can be used to create a variety of art and craft projects. Available in both copper and brass. A single 16" x 20" folded sheet per package.

NUMBER	DESCRIPTION	EACH	3/EA
A33408-8220	Brass	\$29.99	\$27.92
A33408-8230	Copper	29.99	27.92



Artwork by David Klass, davidklass.com

Head & Bust

Figure

Wire Armatures with Bases

Pliable, non-staining wire easily adjusts to almost any position. Bases are formica on heavy particle board.

NUMBER	DESCRIPTION	EACH	12/EA
A34961-1012	12"H, 1/4"Dia wire	\$29.99	\$26.99
A34961-1015	15"H, 1/4"Dia wire	36.46	32.81

Head and Bust

NUMBER	DESCRIPTION	EACH	12/EA
A34961-2013	13"H, 1/8"Dia wire	\$27.76	\$24.98
A34961-2015	15"H, 1/8"Dia wire	36.46	32.81
A34961-2020	20"H, 1/8"Dia wire	46.80	42.13



K-L Mini Long-Nose Pliers and Mini Wire Cutters

Great quality at a value price. 5" spring-loaded, long-nose steel pliers and 5" steel mini wire cutters both have padded blue rubber handles for easy gripping. Perfect for small jobs, beading, and dozens of other uses around the home and studio.

NUMBER	DESCRIPTION	EACH	12/EA
A33083-1010	K Mini Pliers	\$6.07	\$5.45
A33083-1020	L Mini Wire Cutters	6.07	5.45



Sculpture House® Wire Bending Jig

Bend curves, angles, hearts, and more with this versatile tool. Great for making jewelry and wire sculpture pieces, the jig has four steel bending pins that can be placed in any configuration to create custom designs. For hands-free work, simply mount the jig on a bench, vise, or other surface using the included screws. Made of die-cast aluminum with four steel bending pins, the Sculpture House Wire Bending Jig measures 4-1/2" x 1-1/8" x 3/4".

NUMBER	EACH	12/EA
A34355-1001	\$12.66	\$11.39

WIRE GAUGE CHART

The finer the wire, the larger the gauge. Size 24 is excellent for mobiles and jewelry. 14 is good for armatures and sculpture.

GA	DIA. (INCHES)	DIA. (MM)	
0/2	0.289	7.348	
4	0.204	5.189	
6	0.162	4.115	
8.5	0.121	3.264	
9	0.114	2.906	
11.5	0.086	2.179	
12	0.081	2.052	
14	0.064	1.628	
16	0.051	1.290	
18	0.040	1.024	
20	0.032	0.813	
22	0.025	0.643	
24	0.020	0.511	
26	0.016	0.404	
28	0.013	0.320	
32	0.008	0.203	



M Blick® Copper Wire

This solid copper wire is soft and bendable, with a bright finish. Blick Copper Wire is ideal for jewelry making, busbar crafts, as a metal finisher's hanging wire, or for grounding applications.

NUMBER	DESCRIPTION	GA	EACH	12/EA
A33415-1018	25 ft coil	18	\$5.50	\$4.96
A33415-1024	100 ft coil	24	8.66	7.79

N Brass Wire

Popular for jewelry. Also effective with other wire in sculptures. Burnishes like gold.

NUMBER	DESCRIPTION	GA	EACH	12/EA
A33416-1028	75 ft coil	28	\$4.80	\$4.32

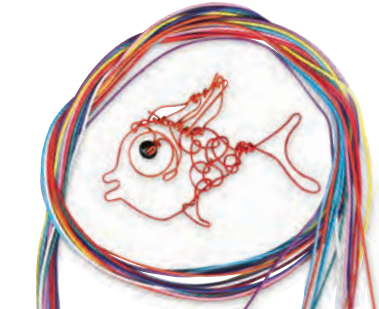

Twisteez® Colored Wire

Fine-gauge, pliable wire. Plastic-coated in bright assorted colors. Perfect for mobiles, sculptures, braiding, twisting, and more. Package of 50 wires, each 30" long. 125 total feet.

NUMBER	EACH	6/EA
A33407-1050	\$12.11	\$10.90

Twisteez Bulk Pack — Package of 200 pieces, each 30" long. 500 total feet.

NUMBER	EACH	6/EA
A33407-1009	\$41.35	\$37.22



Blick® Armature and Sculpture Wire

This economical aluminum wire is lightweight and flexible, perfect for creating underlying structures for sculptures, wall decorations, and more. Available in a variety of thicknesses, it can be used under clay, papier mâché, and plaster roll sculptures. Non-staining and non-corrosive.

NUMBER	GA	LENGTH	EACH	12/EA
A33400-1632	14	32 ft	\$5.97	\$5.38
A33400-1435	14	350 ft	25.48	22.92
A33401-1014	12	350 ft	35.03	31.51
A33400-1152	11.5	20 ft	9.82	8.79
A33400-1155	11.5	50 ft	14.64	13.17
A33400-1950	9	50 ft	13.08	11.58
A33400-1610	6	10 ft	10.44	9.39
A33400-1410	4	10 ft	14.19	12.77

Aluminum Wire

Soft, flexible aluminum is easily shaped. Thin coating eliminates aluminum marks.

NUMBER	DESCRIPTION	GA	EACH	6/EA
A33402-1050	50 ft coil	9	\$13.47	\$11.97
A33404-2050	50 ft coil	11.5	14.20	12.78

Dark Annealed Wire

This soft wire is coated with rust inhibitor.

NUMBER	DESCRIPTION	GA	EACH	6/EA
A33403-1005	5 lb Spool	18	\$26.93	\$24.06
A33403-1050	50 ft coil	18	2.07	1.86
A33403-2028	50 ft coil	28	3.57	3.22

Galvanized Wire

This is a rust-resistant "weaving" wire.

NUMBER	DESCRIPTION	GA	EACH	12/EA
A33429-1610	100 ft coil	16	\$6.15	\$5.54
A33405-1018	100 ft coil	18	4.41	3.93
A33405-1020	100 ft coil	20	3.66	3.26
A33405-1028	100 ft coil	28	3.78	3.37
A33405-1032	100 ft coil	32	3.66	3.26



Amaco® WireForm® Soft Metal Rods

WireForm soft metal rods are great for use as craft armatures or to accent jewelry, scrapbooks, and other craft projects. They can be easily coiled, twisted, and bent to the desired shape. Tube of 12" long rods, six per package.

NUMBER	COLOR	DIAMETER	EACH	6/EA
A33417-1110	Aluminum	0.08"	\$10.20	\$9.70
A33417-8111	Copper	0.08"	13.30	11.99
A33417-9061	Brass	0.06"	9.95	8.95



Artwork by Joe Menna, artstation.com/artist/jmenna

Chavant® Prima Plastilina

Prima Plastilina, like Roma Plastilina, is a premium-grade, smooth-working, oil-based modeling clay that never hardens or changes with air exposure. However, Prima Plastilina is all-natural and sulphur-free, with a neutral, non-offensive odor. Package contains 2 lb of tan-colored clay. No. 2 medium consistency only.

NUMBER	EACH	20/EA
A33221-1007	\$15.97	\$14.38



Chavant® Roma Plastilina

One of the world's finest modeling materials, Roma Plastilina is the renowned choice of professional sculptors. An oil-based, non-hardening modeling compound, Roma Plastilina is permanently pliable, works smoothly, and is available in four consistencies: Soft, used for making large sculptures; Medium, generally used for portrait heads, busts, and figure work; and Firm, used in making models and smaller objects. 2 lb package.

NUMBER	DESCRIPTION	COLOR	EACH	10/EA
A33208-2521	Soft	Gray-green	\$15.79	\$14.22
A33208-2502	Medium	Gray-green	15.79	14.22
A33208-2522	Firm	Gray-green	17.91	16.12
A33208-1102	Medium	White	17.91	16.12



Chavant® Jolly King Plasteline

Jolly King offers the finest quality in an economical plasteline. The wax base produces a smooth, pliable, non-hardening modeling material. Sulfur-free formula. Made in the USA. 1 lb package.

NUMBER	EACH	12/EA
A33266-2521	\$5.77	\$5.19



Amaco® Self-Hardening Clays

Objects modeled from Mexican Pottery Clay (red), Marblex (gray), and Stonex (white) air harden without firing or baking. These moist, ready-to-use clays may be hand-shaped, wheel-thrown, and decorated with tempera or acrylic paints.

NUMBER	COLOR	SIZE	EACH	6/EA
A33205-3005	Red	5 lb Package	\$20.28	\$18.25
A33205-3025	Red	25 lb Package	44.36	39.92
A33204-2505	Gray	5 lb Package	15.45	13.90
A33204-2525	Gray	25 lb Package	40.85	36.79
A33247-1005	White	5 lb Package	24.57	22.10
A33247-1025	White	25 lb Package	54.60	49.15



Sargent Art® Professional Sculpture Clay

A versatile, oil-based modeling compound that is firm and dense, ideal for mold-making, prototyping, and other sculpting techniques that require the material to retain as many intricate details as possible. Firm enough to retain its shape while being worked, this clay will soften with enough heat from the artist's hands. It also reacts well with silicone and plaster for mold-making purposes. This non-toxic, non-drying clay can be reworked and reshaped again and again.

NUMBER	COLOR	SIZE	EACH	6/EA
A30578-4912	Terra Cotta	2 lb	\$13.64	\$12.38
A30578-2502	Gray	2 lb	13.64	12.38



Aves® Apoxie Sculpt

The features and benefits of sculpting clay, combined with the adhesive power of epoxy! Great for sculpting, bonding, embellishing, and filling almost anything. Apoxie Sculpt adheres to plastic, wood, metal, ceramic, glass, polymers, foam, and fiberglass. Use it to make cosplay props and accessories, outdoor displays, and 3-D graphics. Easy to mix and use, with a smooth, putty-like consistency and a long working time of 2-3 hours, it self-hardens, and cures to a waterproof semi-gloss finish within 24 hours with no shrinkage. When hard, it can be sanded, drilled, or carved without chipping or cracking. It also accepts paints, stains, and mica powders for an endless range of looks.

NUMBER	COLOR	WEIGHT	EACH	12/EA
A30570-2021	Black	1 lb	\$24.84	\$22.36
A30570-2024	Black	4 lb	46.94	42.25
A30570-1021	White	1 lb	24.84	22.36
A30570-1024	White	4 lb	46.94	42.25



Sculpture House® Boneware Self-Hardening Clay

Boneware is kept soft and pliable as long as desired, if moistened with water and covered with a damp cloth while not in use. The grog in the clay body has a finer consistency than ClayStone. May be decorated with tempera, oil paints, or enamels. Non-toxic. *Does not qualify for free shipping offer. See shipping exceptions on page 648.

NUMBER	SIZE	EACH	12/EA
A33213-2504	4 lb Box	\$15.43	\$13.89
A33213-2550	*50 lb Bag	63.93	57.54



Sculpture House® ClayStone Self-Hardening Clay

A fine, moist, plastic clay body that works like Plastilina, but air-dries hard and durable, with minimal shrinking. Red in color, this product can be worked indefinitely while moist. Moistened with damp sponge during work; cover with plastic to retain moisture. No baking, no casting, no kiln necessary. Non-toxic. *Does not qualify for free shipping offer. See shipping exceptions on page 648.

NUMBER	SIZE	EACH	12/EA
A33255-2984	4 lb Box	\$15.72	\$14.13
A33255-2985	*50 lb Bag	85.96	77.36



Sculpture House® Della Robbia™ Oven Bake Clay

Keep moist and pliable with water. Dry objects for several days before baking. Place in a cold oven leaving door open 2" and bake at 250°F for one hour. Armatures must be removed before baking to prevent cracking. *Does not qualify for free shipping offer. See shipping exceptions on page 648.

NUMBER	SIZE	EACH	6/EA
A33207-0000	4 lb Package	\$14.32	\$12.89
A33207-1050	*50 lb Bag	70.54	63.50



Plastic Bags

Made of heavy-duty polyethylene, excellent for keeping clay moist and workable. 16" x 22" bags are .0015" thick. Package of 12.

NUMBER	EACH	12/EA	24/EA
A34922-1012	\$3.49	\$3.13	\$2.98



Van Aken® Plastalina Modeling Clay

This pigmented oil-based modeling compound is a favorite of sculptors, model makers, clay animators, and artists of all ages. Smooth consistency, brilliant color range. Mix colors with Ivory and White to obtain tints, with Black to achieve shades, and with each other to achieve intermediate hues. Model with the hands or with clay tools for fine detail. It never hardens but remains pliable and plastic and can be used again and again; in fact, its consistency improves with age. Non-toxic.

1 lb		EACH	8/EA
A33268-2051	Black	\$4.03	\$3.62
A33268-4861	Blue	4.03	3.62
A33268-8001	Brown	4.03	3.62
A33268-7151	Dark Green	4.03	3.62
A33268-1121	Flesh	4.03	3.62
A33268-4301	Golden Ochre	4.03	3.62
A33268-2521	Gray	4.03	3.62
A33268-7261	Gray Green	4.03	3.62
A33268-7031	Green	4.03	3.62
A33268-1091	Ivory	4.03	3.62
A33268-3041	Magenta	4.03	3.62
A33268-4511	Orange	4.03	3.62
A33268-5331	Pastel Blue	4.03	3.62
A33268-7331	Pastel Green	4.03	3.62
A33268-3031	Pastel Pink	4.03	3.62
A33268-4331	Pastel Yellow	4.03	3.62
A33268-2981	Red	4.03	3.62
A33268-2621	Silver Gray	4.03	3.62
A33268-8141	Terra Cotta	4.03	3.62
A33268-5121	Turquoise	4.03	3.62
A33268-6511	Violet	4.03	3.62
A33268-4021	Yellow	4.03	3.62
A33268-1041	White	4.03	3.62

4.5 lb		EACH	4/EA
A33268-2055	Black	\$16.37	\$14.73
A33268-4865	Blue	16.37	14.73
A33268-8005	Brown	16.37	14.73
A33268-7155	Dark Green	16.37	14.73
A33268-1125	Flesh	16.37	14.73
A33268-2525	Gray	16.37	14.73
A33268-7265	Gray Green	16.37	14.73
A33268-7035	Green	16.37	14.73
A33268-1095	Ivory	16.37	14.73
A33268-2985	Red	16.37	14.73
A33268-2505	Sculptor Gray	16.37	14.73
A33268-8145	Terra Cotta	16.37	14.73
A33268-1045	White	16.37	14.73
A33268-4025	Yellow	16.37	14.73

Magic Mud® Multi-Project Pack

Includes 25 lb of soft, air-dry, natural clay, an 8" child-safe wire cutter, and a teacher's guide with lesson plans. Non-staining, cleans up easily. Air-dried objects can be turned back into mud again by breaking them into small pieces and adding water! Can also be fired in a kiln.

NUMBER	EACH
A30531-1025	\$39.75

Magic Mud Wire Cutter — For slicing and cutting clay.

The 3" long hardwood handles are fastened to child-safe, fine-quality 8" stainless steel wire.

NUMBER	DESCRIPTION	EACH
A30531-1008	8" Wire Clay Cutter	\$6.35



Van Aken® Claytoon™ Sets

Renowned for its smooth consistency and brilliant colors, Claytoon Modeling Clay has been featured in many award-winning claymation productions. Preferred by sculptors, modelmakers, animators, and artists of all ages, it remains pliable and never hardens, even if left out for days, weeks, even months. Claytoon also offers creative fun for young children, for family activities, and in classrooms. The 1 lb clay sets contain four different colors (4 oz each), each individually wrapped for freshness, plus easy-to-follow instructions and a Claytoon project. Non-toxic and gluten-free.

NUMBER	COLOR	EACH	12/EA
A33227-0069	Cool	\$4.25	\$3.82
A33227-0089	Earthtone	4.25	3.82
A33227-0059	Hot	4.25	3.82
A33227-0049	Neutral	4.25	3.82
A33227-0019	Primary	4.25	3.82
A33227-0029	Sweetheart	4.25	3.82



Sargent Art® Non-Hardening Modeling Clays

A smooth, non-hardening clay ideal for freehand modeling, claymation, and realistic sculpting. Colors can be mixed and blended to create natural and neutral colors. Each 1 lb package contains four 1/4 lb clay sticks. For children age three and older. For set contents, visit DickBlick.com.

1 lb Sets

NUMBER	COLOR	EACH	24/EA
A33281-1009	Assorted Primary	\$3.66	\$3.27
A33281-2009	Assrt Colors of My Friends	3.66	3.27
A33281-3009	Assorted Natural	3.66	3.27
A33281-2981	Blue	3.66	3.27
A33281-1101	Cream	3.66	3.27
A33281-2501	Gray	3.66	3.27
A33281-2041	Jet Black	3.66	3.27
A33281-5011	Red	3.66	3.27
A33281-3761	Terra Cotta	3.66	3.27
A33281-1021	Titanium White	3.66	3.27

5 lb		EACH	6/EA
A33281-1105	Cream	\$14.49	\$13.05
A33281-4915	Terra Cotta	14.49	13.05
A33281-8005	Brown	14.49	13.05
A33281-7015	Green	14.49	13.05
A33281-2505	Gray	14.49	13.05
A33281-1025	White	14.49	13.05

Set of 24, 3.2lb

NUMBER	COLOR	SIZE	EACH	6/EA
A33281-1024	N Assorted	3.2lb	\$14.99	\$13.49

Set of 48, 6.3lb

NUMBER	COLOR	SIZE	EACH	6/EA
A33281-1048	N Assorted	6.3lb	\$29.49	\$26.55



A Crayola® Modeling Clay

Smooth and pliable, this oil-based clay can be reshaped again and again and will never harden. Non-crumbling, non-toxic, and non-staining. **Basic Assortment, 1 lb** — 1/4 lb each of Red, Blue, Yellow, and Green, individually wrapped. **NUMBER** EACH 12/EA **A33216-1006** \$3.74 \$3.37

Neutral Assortment, 1 lb — 1/4 lb each of White, Orange, Black, and Light Brown, individually wrapped. **NUMBER** EACH 12/EA **A33216-1001** \$3.78 \$3.41

Jumbo Assortment, 2 lb — 1/4 lb each of Red, Blue, Green, Yellow, Brown, Black, Orange, and White, individually wrapped. **NUMBER** EACH 12/EA **A33216-1002** \$7.89 \$7.10

Classic Assortment, 1/4 lb — 8 sticks of clay, one each of Pink, Red, Orange, Yellow, Green, Light Blue, Blue, and Purple. **NUMBER** EACH 12/EA **A33216-1003** \$2.53 \$2.28

Neutral Assortment, 1/4 lb — Includes two sticks each of Black, Gray, White, and Brown. **NUMBER** EACH 12/EA **A33216-1004** \$2.53 \$2.28

15 oz Bucket **NUMBER** COLOR EACH 12/EA **A33216-2020** Black \$6.28 \$5.65 **A33216-1020** White 6.28 5.65

B Crayola® Modeling Clay Classpack™

Great for large groups, this classpack includes 24 sticks each of 12 colors, including Black, Blue, Brown, Gray, Green, Light Blue, Orange, Pink, Purple, Red, White, and Yellow. 10 lb total. **NUMBER** EACH 4/EA **A33216-1019** \$73.21 \$65.88



Sculpey® EZ Shape Modeling Clay

An easy-to-use, wax-based modeling clay that never dries out, EZ Shape sticks to itself with just a small amount of pressure, making it easy for youngsters to form fun shapes. It's free of common allergens, including wheat gluten, sulphur, latex, nuts, dairy, and animal by-products. For set contents, visit DickBlick.com. For children age four and older.

NUMBER	DESCRIPTION	EACH	6/EA
A33292-1061	Primary Colors	\$3.64	\$3.27
A33292-1031	Bright Colors	3.64	3.27
A33292-1020	20 Assorted Colors	4.90	4.40
A33292-1052	52 Assorted Colors	7.79	6.99



DAS® Modeling Clay

Das hardens within 24 hours (no oven baking required!) to a smooth, even finish that can be applied to a variety of supports, and varnished or decorated with paint or markers when dry. Excellent plasticity and pliability make it suitable for all ages and all techniques. Blendable colors stay bright and vivid, even when dry. Gluten-free and non-toxic.

NUMBER	DESCRIPTION	EACH	6/EA
A30538-8141	Terra Cotta, 1.1 lb	\$5.46	\$4.91
A30538-8142	Terra Cotta, 2.2 lb	10.31	9.28
A30538-1041	White, 1.1 lb	5.46	4.91
A30538-1042	White, 2.2 lb	10.31	9.28
A30538-2162	Stone, 2.2 lb	11.48	10.33



Das® Junior Air-Dry Clay

Ideal for school and educational activities of all kinds, this mineral-based clay is easy to use and air-dries within 24 hours. No baking required! Soft and versatile, Das Junior has excellent plasticity. Use it with molds, paint it with poster paints or felt markers. You can even engrave it. When dry, objects will have a velvety feel. 100 g packs.

NUMBER	COLOR	EACH	6/EA
A34353-2020	Black	\$4.10	\$3.68
A34353-8000	Brown	4.10	3.68
A34353-7030	Dark Green	4.10	3.68
A34353-5020	Light Blue	4.10	3.68
A34353-7010	Light Green	4.10	3.68
A34353-3040	Magenta	4.10	3.68
A34353-4510	Orange	4.10	3.68
A34353-3010	Red	4.10	3.68
A34353-1020	White	4.10	3.68
A34353-4010	Yellow	4.10	3.68

Class Pack — Includes 10, 100 g packs, one each of Black, Brown, Dark Green, Light Blue, Light Green, Magenta, Orange, Red, White, and Yellow.

NUMBER	EACH	6/EA
A34353-1010	\$38.21	\$34.39



Activa® Hearty Clay

A soft, pliable, lightweight clay that air-dries within 24 hours, Hearty Clay reproduces the finest details. It has a bright white color, which can be tinted with acrylic paint, and chalks, embossing powders, and other dry agents can be applied after drying. This no-bake, self-hardening clay is great for making miniatures, jewelry, and scrapbook embellishments, plus card making, rubber stamping and other children's crafts. Gluten-free and acid-free. 5.25 oz package.

NUMBER	EACH	6/EA
A30568-1005	\$13.64	\$12.29



Activa® Plus Clay

An ultra-fine, premium-grade, self-hardening clay that yields excellent detail, Activa Plus has superior strength and durability, and it won't crumble. Moist, odorless, and ready to use, it's carvable, sandable, drillable, and it accepts all finishes. For hand-building, wheel-throwing, and sculpting. Can be fired in a kiln.

NUMBER	DESCRIPTION	EACH	6/EA
A33275-1041	2.2 lb White	\$10.26	\$9.23
A33275-8141	2.2 lb Terra Cotta	10.26	9.23
A33275-2051	2.2 lb Black	10.70	9.62
A33275-1042	22 lb White	72.38	65.14
A33275-8142	22 lb Terra Cotta	69.20	62.28



Sargent® Art Flexible Clay

This unique air-dry clay is easy to use and mold, and remains flexible when dry, with no cracking! Great for sculpting delicate details such as flower petals and leaves, Flexible Clay stays bendable and can be manipulated after it dries, ideal for stop-motion sculpts. Its neutral white color can be colored with acrylics or watercolor paints both during sculpting and after it hardens. Pieces generally dry overnight. Non-toxic. 1 lb package.

NUMBER	SIZE	EACH	12/EA
A34370-1001	1 lb	\$15.11	\$13.61

Activa® Activ-Clay™ Air Dry Clay

This dense, durable, fine-grain clay is great for all types of classroom activities, including character sculpting and jewelry making. Soft and easy to work with, it requires no baking. It can also be carved and painted when dry.

NUMBER	COLOR	SIZE	EACH	12/EA
A33264-8141	Terra Cotta	1 lb	\$7.53	\$6.78
A33264-8143	Terra Cotta	3.3 lb	19.32	17.40
A33264-1041	White	1 lb	7.53	6.78
A33264-1043	White	3.3 lb	19.32	17.40

Polyform® Model Air™ Air Dry Modeling Clay

Model Air is a lightweight and durable air-dry clay that is extremely pliable and easy to smooth. Perfect for school projects, jewelry, sculptures, and more, Model Air needs no oven or kiln to cure — and it dries completely within 24 hours. It can be decorated with paint and markers when dry. Unused clay should be stored in an airtight container.

NUMBER	COLOR	SIZE	EACH	6/EA
A33659-1022	White	2.2lb	\$7.53	\$6.78
A33659-4912	Terra Cotta	2.2lb	7.53	6.78



Activa® La Doll® Premier Air-Dry Clay

An advanced formula, like La Doll, but with a finer body, allowing for greater detail, exceptional strength, ultra-lightweight pieces, and an incredible, bright white finish. Can be blended with La Doll for increased strength. Non-crumbling, non-stick. Natural Stone color. 10-1/2 oz package.

NUMBER	SIZE	EACH	6/EA
A33279-1040	10-1/2 oz	\$13.86	\$12.47

Activa® La Doll® Satin Smooth Air-Dry Clay

The perfect air-dry clay for fine detail work, La Doll contains highly refined pumice, talc, and small amounts of paper pulp and binders, resulting in an extremely pliable clay that can be worked with indefinitely if kept moist. It adheres to wire mesh, Rigid-Wrap, paper, glass, plastic, wood, and Styrofoam, and accepts acrylics, oils, waterbased paints, and dry finishing powders. Dissolve it in water to use as a finish coat — or soak it with paper and cloth to be formed into shapes. Can be carved, drilled, or sanded when dry. Air-dries with minimal shrinkage. Natural Stone color. 1 lb package.

NUMBER	SIZE	EACH	6/EA
A33278-1041	1 lb	\$14.29	\$12.86



Creative Paperclay®

This lightweight, air-hardening material is soft and easy to mold and shape. After it dries hard in 1-3 days, Paperclay can be painted with tempera, watercolor, acrylic, enamel, markers, and more. It carves easily like plaster. Create jewelry, dolls, ornaments, miniatures, sculptures, wall hangings, and more. Non-toxic; contains all natural ingredients. For a wide range of skill levels.

NUMBER	SIZE	EACH	12/EA
A33230-1005	8 oz package	\$7.63	\$6.87
A33230-1006	16 oz package	13.09	11.78

Pearl Paperclay®

Pearl Paperclay is like the original Creative Paperclay but is heavier, firmer, not quite as easy to carve, and slightly less durable. More economical for classroom use. It air-hardens in 1-3 days or may be oven-baked to speed dry. White in color, it can be finished with any kind of paint or markers and carved when dry. 17.5 oz bag.

NUMBER	SIZE	EACH	6/EA
A33222-1006	17.5 oz	\$5.81	\$4.91

Sargent Art® Sculpt It!™

Ideal for freehand modeling and creating realistic sculptures — no kiln or baking required. Dries to an almost ceramic hard surface with minimal shrinkage. Can be moistened while pliable for piece-to-piece adhesion, smoothing, blending, and to avoid cracking.

NUMBER	SIZE	EACH	6/EA
A33269-1001	2 lb Bucket	\$14.30	\$12.87
A33269-1010	10 lb Bucket	63.48	57.13

Classroom Pack — Includes 150, 0.67 oz packages of White Sculpt-It!

NUMBER	SIZE	EACH	6/EA
A33269-2009	Classroom Pack	\$65.71	\$59.13



Sargent Art® Art-Time Dough

Pliable, safe, and easy for kids to work with, Art-Time Dough is great for a variety of modeling projects. Reusable when stored in its container between uses. Non-toxic.

NUMBER	COLOR	SIZE	EACH	6/EA
A33296-4863	Blue	3 lb	\$12.58	\$11.33
A33296-7013	Green	3 lb	12.58	11.33
A33296-4513	Orange	3 lb	12.58	11.33
A33296-3063	Pink	3 lb	12.58	11.33
A33296-3013	Red	3 lb	12.58	11.33
A33296-5113	Turquoise	3 lb	12.58	11.33
A33296-6513	Violet	3 lb	12.58	11.33
A33296-1043	White	3 lb	12.58	11.33
A33296-4023	Yellow	3 lb	12.58	11.33

Class Pack — Includes 3 lb each of Yellow, Orange, Red, Violet, Green, and Blue.

NUMBER	SIZE	EACH	6/EA
A33296-1069	Class Pack	\$71.73	\$64.57



Scentco® Air Dough

This super lightweight, highly elastic dough dries in 12 hours with no baking! Ideal for ages and skill levels, once dry it can be decorated with markers, paint, colored pencils, and more. Non-stick formula cleans up with soap and water. Comes in a resealable plastic bag for storage. Non-toxic and gluten-free.

NUMBER	COLOR	SIZE	EACH	6/EA
A84308-1022	White	300 g	\$10.99	\$9.99



Crayola® Air-Dry Clay

Soft and pliable air-dry modeling material allows kids to create arts and crafts without the need for an oven or kiln. Clay softens easily with water and quickly cleans from hands and surfaces. Once dry, pieces can be decorated with markers, acrylic paints, tempera, or watercolors.

NUMBER	DESCRIPTION	EACH	4/EA
A33272-1125	2.5 lb Bucket, White	\$7.51	\$6.76
A33272-8172	2.5 lb Bucket, Terra Cotta	7.51	6.76
A33272-1005	5 lb Bucket, White	13.92	12.52
A33272-1025	25 lb Value Pack, White	47.47	42.72



Crayola® Dough

A soft, brilliantly colored, non-toxic modeling material, Crayola Dough's smooth consistency is easy for small hands to manipulate. Washes easily from most surfaces. Return Crayola Dough to its container to prevent drying. To soften dough, slowly add a few drops of water and knead. 3 lb plastic tub.

NUMBER	COLOR	EACH	8/EA
A33203-5003	Blue	\$12.23	\$10.99
A33203-7000	Green	12.23	10.99
A33203-4500	Orange	12.23	10.99
A33203-3003	Red	12.23	10.99
A33203-6503	Violet	12.23	10.99
A33203-4003	Yellow	12.23	10.99



Classpack® — Includes 3 lbs each of six colors.

NUMBER	EACH
A33203-0069	\$66.18

Classpacks® — Includes 24, 3 oz tubs of Crayola Dough, three each of Brown, Green, Orange, Red, Sky Blue, Violet, White, and Yellow.

NUMBER	DESCRIPTION	SIZE	EACH
A33203-1009	24-pack	3 oz	\$30.19

Classpacks® — Includes 24, 3 oz tubs of Crayola Dough, three each of Brown, Green, Orange, Red, Sky Blue, Violet, White, and Yellow, plus 81 Tools.

NUMBER	DESCRIPTION	SIZE	EACH
A33203-1019	24-pack, 81 tools	3 oz	\$57.18

Classpacks® — Includes 30, 1 oz pieces of Crayola Dough in 10 assorted colors, in clear plastic bags.

NUMBER	DESCRIPTION	SIZE	EACH
A33203-1029	30-pack	1 oz	\$17.53

Classpacks® — Includes 48, 3 oz tubs of Crayola Dough, six each of Brown, Green, Orange, Red, Sky Blue, Violet, White, and Yellow.

NUMBER	DESCRIPTION	SIZE	EACH
A33203-1039	48-pack	3 oz	\$58.33



Crayola® Model Magic™

Extremely lightweight and soft, Model Magic air dries in 24 hours with no baking. Pieces join easily. Carvable and sandable. Decorate with tempera, watercolors, acrylics, enamel, or markers. Non-greasy formula won't stick, stain, flake, or crumble, for minimal cleanup. Assorted buckets hold four 8 oz packages of each color. Great for large classroom settings, the classpacks include free lesson plan booklets.

NUMBER	COLOR	EACH	4/EA
A33214-1008	Natural Assorted	\$28.85	\$25.99
A33214-0002	Primary Assorted	28.85	25.99
A33214-1002	White	28.85	25.99

4 oz Packages

NUMBER	COLOR	EACH	4/EA
A33214-2004	Black	\$4.65	\$4.20
A33214-5004	Blue	4.65	4.20
A33214-7014	Green	4.65	4.20
A33214-8254	Natural Bisque	4.65	4.20
A33214-8834	Natural Earth Tone	4.65	4.20
A33214-8174	Natural Terra Cotta	4.65	4.20
A33214-4514	Orange	4.65	4.20
A33214-3004	Red	4.65	4.20
A33214-1004	White	4.65	4.20
A33214-4004	Yellow	4.65	4.20

Value Pack — Contains 12, 8 oz pouches of White.

NUMBER	EACH	4/EA
A33214-1006	\$67.75	\$60.99

White Classpack — Contains 75, 1 oz pouches of White.

NUMBER	EACH	4/EA
A33214-0759	\$54.75	\$49.28

Assorted Colors Classpack — Contains 75, 1 oz pouches of assorted colors.

NUMBER	EACH	4/EA
A33214-1759	\$51.45	\$46.30



Artwork by Sherry Godsil



A Original Sculpey
Original Sculpey is America's first polymer clay and a favorite among kids, parents, teachers, and professionals. Soft and pliable until you bake it, when it reveals its durability and strength. May be sanded, drilled, carved, and painted with waterbased acrylic paints.

NUMBER	COLOR	SIZE	EACH	12/EA
A33219-1034	Terra Cotta	1-3/4 lb	\$12.90	\$12.47
A33219-1002	White	1-3/4 lb	12.90	12.47
A33219-1003	White	3-3/4 lb	31.27	28.14
A33219-1008	White	8 lb	49.78	44.80
A33219-1024	White	24 lb	135.62	125.31

B Super Sculpey
This ceramic-like sculpting compound is easy to work with and oven-bakeable — no kiln required! Semi-translucent finish is excellent for creating prototypes and sculptures that require fine details. May be carved, sanded, and drilled after baking. Resists chips and shattering.

NUMBER	SIZE	EACH	6/EA
A33217-3716	1 lb	\$13.64	\$12.08
A33217-3718	8 lb	98.73	88.85

C Super Sculpey Medium Blend
Firm enough to hold details beautifully, yet soft and workable enough to shape and blend pieces together easily, Medium Blend is the perfect marriage of Super Sculpey and Super Sculpey Firm. Ideal for additive methods (particularly in small increments), it can be carved, painted, sanded, and drilled after oven baking. Bars are scored for easy cutting. Resists chipping and shattering. 1 lb box.

NUMBER	SIZE	EACH	6/EA
A30496-1001	1 lb	\$17.46	\$15.72

D Super Sculpey Firm
This extra-firm gray sculpting clay is perfect for catching the tiniest details. Shatter-resistant and chip-resistant, it bakes to a very durable finish and can be carved, sanded, painted, and drilled after baking. 1 lb box.

NUMBER	SIZE	EACH	6/EA
A33273-1009	1 lb	\$17.46	\$15.72



E Sculpey Clay Softener
Clay softener is an easy-to-use liquid; simply add a few drops and knead into clay that is dry or crumbly. Available in a 1 oz (30 ml) plastic bottle.

NUMBER	DESCRIPTION	EACH	6/EA
A33913-1003	Lightweight Oven-Bake Clay	\$5.95	\$5.36

F Sculpey Glaze
An air-drying, water-thinnable acrylic glaze for coating all baked Sculpey products, Sculpey Glaze produces a clean, highly lustrous finish. 1 oz (30 ml) glass jar.

NUMBER	DESCRIPTION	EACH	6/EA
A33218-1013	Gloss	\$4.17	\$3.75
A33218-1005	Satin	4.17	3.75

G Sculpey Bake Shop Oven-Bake Clay
Kids love to make and bake clay people, animals, and ornaments — and Bake Shop clay makes it more fun than ever. Soft and easy to use, the clay is lead-free and phthalate-free. Variety pack includes 12 colors (14 oz total), a modeling tool, and instructions for making puppy, Santa, and gingerbread house ornaments.

H Sculpey UltraLight Clay
This very lightweight white clay is soft and easy to condition by hand, but bakes to a hard, durable finish. Perfect for armatures, paper crafting, and floating projects. 8 oz package.

I Liquid Sculpey Liquid Polymer Clay
A liquid form of polymer clay, Liquid Sculpey is a versatile product that can be poured into bakeable molds, dribbled onto raw or baked Sculpey, used as a grout, or used for window clings. After baking, it becomes a strong medium for making home décor or jewelry. The bottles have a twist cap for precise flow control that opens completely to fill molds. Open it half-way for writing and other detail work. Use Liquid Sculpey as a glue to bond both cured and uncured pieces to one another. Baking will form a strong and lasting bond. Sets include three 1 oz squeeze bottles.

NUMBER	COLOR	EACH	6/EA
A33912-1009	Glam Metallics	\$12.11	\$10.90
A33912-1019	Primary Colors	12.11	10.90
A33912-1029	Metallics	12.11	10.90
A33912-1039	Basics	12.11	10.90



Sculpey Premo
Use Sculpey Premo alone, or mix it with other polymer clays, powders, or pigments! Smooth and kneadable, yet firm enough for details, it's more flexible, durable, and less breakable than other clays after oven-baking.

2 oz Blocks

NUMBER	COLOR	EACH	12/EA
A32334-2973	Alizarin Crimson	\$2.97	\$2.68
A32334-8153	Beige	2.97	2.68
A32334-2053	Black	2.97	2.68
A32334-1163	Blush	2.97	2.68
A32334-4703	Burnt Orange	2.97	2.68
A32334-8023	Burnt Umber	2.97	2.68
A32334-2983	Cadmium Red	2.97	2.68
A32334-4023	Cadmium Yellow	2.97	2.68
A32334-3023	Cayenne	2.97	2.68
A32334-4843	Cobalt Blue	2.97	2.68
A32334-1453	Ecu	2.97	2.68
A32334-2963	Fuchsia	2.97	2.68
A32334-7013	Green	2.97	2.68
A32334-7083	Jungle	2.97	2.68
A32334-5073	Navy	2.97	2.68
A32334-4513	Orange	2.97	2.68
A32334-6173	Periwinkle	2.97	2.68
A32334-3913	Pomegranate	2.97	2.68
A32334-5623	Purple	2.97	2.68
A32334-8003	Raw Sienna	2.97	2.68
A32334-2593	Rhino Gray	2.97	2.68
A32334-2753	Slate	2.97	2.68
A32334-7073	Spanish Olive	2.97	2.68
A32334-4393	Sunshine	2.97	2.68
A32334-5123	Turquoise	2.97	2.68
A32334-4863	Ultramarine Blue	2.97	2.68
A32334-1183	Wasabi	2.97	2.68
A32334-1043	White	2.97	2.68
A32334-4043	Zinc Yellow	2.97	2.68

1 lb Blocks

NUMBER	COLOR	EACH	6/EA
A32334-8151	Beige	\$20.55	\$18.49
A32334-2021	Black	20.55	18.49
A32334-1041	White	20.55	18.49

Sampler

NUMBER	COLOR	EACH	6/EA
A33218-1094	White	20.55	18.49



Sculpey Premo Color Samplers
The perfect way to experiment with a variety of Sculpey Premo colors. Choose sets of 12 or 24, 1 oz blocks. For set colors, visit DickBlick.com.

NUMBER	COLOR	SIZE	EACH	6/EA
A33920-1012	Classics	Set of 12	\$15.78	\$14.34
A33920-1112	Mixed FX	Set of 12	15.78	14.34
A33920-1024	Sampler	Set of 24	28.60	25.74



Artwork by Sherry Godsil



Sculpey III
The same excellent handling qualities as regular Sculpey, only softer and more pliable, requiring little or no conditioning. It bakes to hardness in the oven at 275°F for 15 minutes per 1/4" thickness. Requires no painting, but a glossy effect can be achieved by applying Sculpey Glaze.

2 oz Blocks

NUMBER	COLOR	EACH	6/EA
A33218-1054	Acid Yellow	\$2.63	\$2.42
A33218-1014	Ballerina	2.63	2.42
A33218-8144	Beige	2.63	2.42
A33218-2004	Black	2.63	2.42
A33218-2804	Black Glitter	2.63	2.42
A33218-5004	Blue	2.63	2.42
A33218-5804	Blue Glitter	2.63	2.42
A33218-7163	Camouflage	2.63	2.42
A33218-3104	Candy Pink	2.63	2.42
A33218-8104	Chocolate	2.63	2.42
A33218-3794	Deep Red Pearl	2.63	2.42
A33218-3714	Dusty Rose	2.63	2.42
A33218-2524	Elephant Gray	2.63	2.42
A33218-7054	Emerald	2.63	2.42
A33218-3804	Garnet Glitter	2.63	2.42
A33218-6163	Gentle Plum	2.63	2.42
A33218-1904	Glow-in-the-Dark	2.63	2.42
A33218-4054	Gold	2.63	2.42
A33218-7174	Granny Smith	2.63	2.42
A33218-8014	Hazelnut	2.63	2.42
A33218-9094	Jewelry Gold	2.63	2.42
A33218-4514	Just Orange	2.63	2.42
A33218-7154	Leaf Green	2.63	2.42
A33218-4414	Lemonade	2.63	2.42
A33218-5034	Navy Pearl	2.63	2.42
A33218-1094	Pearl	2.63	2.42
A33218-3844	Pink Glitter	2.63	2.42
A33218-4774	Poppy	2.63	2.42
A33218-1034	Princess Pearl	2.63	2.42
A33218-6004	Purple	2.63	2.42
A33218-3004	Red	2.63	2.42
A33218-3734	Red Hot Red	2.63	2.42
A33218-9300	Silver	2.63	2.42
A33218-5074	Sky Blue	2.63	2.42
A33218-6034	Spring Lilac	2.63	2.42
A33218-7024	String Bean	2.63	2.42
A33218-8924	Suede Brown	2.63	2.42
A33218-8234	Tan	2.63	2.42
A33218-5084	Teal	2.63	2.42
A33218-1064	Teal Pearl	2.63	2.42
A33218-1024	Translucent	2.63	2.42
A33218-5114	Turquoise	2.63	2.42
A33218-5844	Turquoise Glitter	2.63	2.42
A33218-6504	Violet	2.63	2.42
A33218-6804	Violet Glitter	2.63	2.42
A33218-1004	White	2.63	2.42
A33218-4004	Yellow	2.63	2.42

8 oz Blocks

NUMBER	COLOR	EACH	6/EA
A33218-2008	Black	\$9.21	\$8.29
A33218-8018	Hazelnut	9.21	8.29
A33218-3008	Red Hot Red	9.21	8.29
A33218-1008	Translucent	9.21	8.29
A33218-1108	White	9.21	8.29

1 lb Blocks

NUMBER	COLOR	EACH	6/EA
A33218-8149	Beige	\$19.83	\$17.84
A33218-2009	Black	19.83	17.84
A33218-1109	White	19.83	17.84

FIMO Professional Polymer Clay

An innovative, enhanced version of Fimo Classic, this is the perfect modeling material for professionals, artists, and those who create multiples of the same design. Compatible with Fimo Soft and Fimo Effect, it has exceptional dimensional stability for sophisticated techniques and fine details. The core range includes a variety of vibrant colors. Five additional True Colors help you create a spectrum of harmonizing shades. For shades and mixing ratios, visit DickBlick.com. Resealable 2 oz packages.

2 oz Blocks

NUMBER	COLOR	EACH	6/EA
A30497-2023	Black	\$4.26	\$3.83
A30497-3723	Bordeaux	4.26	3.83
A30497-3153	Carmine	4.26	3.83
A30497-1193	Champagne	4.26	3.83
A30497-8103	Chocolate	4.26	3.83
A30497-2503	Dolphin Grey	4.26	3.83
A30497-6043	Lavender	4.26	3.83
A30497-7153	Leaf Green	4.26	3.83
A30497-4923	Lemon	4.26	3.83
A30497-5043	Navy Blue	4.26	3.83
A30497-4003	Ochre	4.26	3.83
A30497-4513	Orange	4.26	3.83
A30497-6003	Purple	4.26	3.83
A30497-7093	Sap Green	4.26	3.83
A30497-4913	Terra Cotta	4.26	3.83
A30497-5013	True Blue	4.26	3.83
A30497-7013	True Green	4.26	3.83
A30497-3043	True Magenta	4.26	3.83
A30497-3013	True Red	4.26	3.83
A30497-4013	True Yellow	4.26	3.83
A30497-5133	Turquoise	4.26	3.83
A30497-5133	Ultramarine	4.26	3.83
A30497-6063	Violet	4.26	3.83
A30497-1023	White	4.26	3.83



Sculpey III Multi-Packs

Classic Colors — Contains 10, 2 oz blocks: White, Black, Chocolate, Blue, Yellow, Red, Beige, Emerald, Purple, and Just Orange.

Bright Ideas — Contains 10, 2 oz blocks: Violet, Purple, Turquoise, Teal Pearl, Granny Smith, Yellow, Just Orange, Red Hot Red, Candy Pink, and White

30-Color Sampler — A great way to try a variety of Sculpey III clay colors. Set includes 1 oz blocks in Red, Deep Red Pearl, Red Hot Red, Just Orange, Yellow, Lemonade, Glow in the Dark, Granny Smith, Emerald, Turquoise Glitter, Teal Pearl, Turquoise, Blue Glitter, Sky Blue, Navy Pearl, Blue, Purple, Spring Lilac, Violet Glitter, Pink Glitter, Ballerina, Beige, Gold, Chocolate, Suede Brown, Black, Silver, Translucent, Pearl, and White.

Natural Colors — Contains 10, 2 oz blocks: Elephant Gray, Hazelnut, Suede Brown, String Bean, Emerald, Turquoise, Blue, Tan, Beige, and White.



FIMO Soft Polymer Clay

Fimo Soft is now easier to knead than ever before, making it perfect for children and crafters of all skill levels. Although softer than Fimo Classic, objects made with Fimo Soft are very durable and strong after baking in a kitchen oven for 30 minutes at 265°F.

2 oz Blocks

NUMBER	COLOR	EACH	10/EA
A33228-7233	Apple Green	\$3.99	\$3.58
A33228-2013	Black	3.99	3.58
A33228-5063	Brilliant Blue	3.99	3.58
A33228-8223	Caramel	3.99	3.58
A33228-3453	Cherry	3.99	3.58
A33228-8103	Chocolate	3.99	3.58
A33228-8013	Cognac	3.99	3.58
A33228-2503	Dolphin Grey	3.99	3.58
A33228-7043	Emerald	3.99	3.58
A33228-3253	Indian Red	3.99	3.58
A33228-5043	Lavender	3.99	3.58
A33228-4063	Lemon	3.99	3.58
A33228-7243	Lime Green	3.99	3.58
A33228-5463	Pacific Blue	3.99	3.58
A33228-5113	Peppermint	3.99	3.58
A33228-1123	Pale Pink	3.99	3.58
A33228-6173	Plum	3.99	3.58
A33228-5633	Purple Glitter	3.99	3.58
A33228-3363	Raspberry	3.99	3.58
A33228-4923	Sahara	3.99	3.58
A33228-4933	Sunflower	3.99	3.58
A33228-7913	Tropical Green	3.99	3.58
A33228-1013	White	3.99	3.58
A33228-5643	Windsor Blue	3.99	3.58



Activa® Activ-Tools™ Clay Cutter Sets

Great for creating clay shapes for embellishing larger projects, or for free-standing projects. Simply roll out clay or modeling medium to the desired thickness, place the cutter on the clay, press down firmly, then remove. Sets include five cutters, each measuring 40 mm, a popular size for crafters, artists, and jewelry makers. For set contents, visit DickBlick.com.

NUMBER	DESCRIPTION	EACH	12/EA
A35142-1002	Designer	\$7.63	\$6.99
A35142-1001	Geometric	7.63	6.99



Sculpey® Essential Tool Kit

A fantastic collection of the most sought-after clay tools, all designed especially to be compatible with clay. Includes an 8" clay roller, super slicer, 6 mm detail tool, clay knife, texture wheel with interchangeable vine and rope design wheels, blunt point tool, and needle end pointer with cover.

NUMBER	EACH	6/EA
A34212-1008	\$32.75	\$29.47



Kemper® Pattern Cutter Sets

Like miniature cookie cutters for clay or dough! Use the cut-out forms to adorn ceramic boxes, vases, and other items. Designs can also be created by impressing the cutters in the surface of wet clay items. Rust-free and equipped with a spring-returned plunger for ejecting the clay cut-outs. Sets include a range of sizes measuring approximately 3/4", 5/8", 1/2", 7/16", and 3/8" in each shape.

NUMBER	SHAPE	EACH	6/EA
A34921-2003	Circle	\$15.73	\$14.15
A34921-2001	Flower	15.95	14.35
A34921-2002	Heart	16.13	14.52
A34921-2005	Oval	15.82	14.23
A34921-2007	Square	17.15	15.43
A34921-2006	Star	15.93	14.34
A34921-2004	Tear Drop	16.55	14.89
A34921-2008	Triangle	16.45	14.80



Kemper® Klay Gun

Used to force clay, bread dough, or jewelry clay through shaped openings in a series of interchangeable discs. Use for decorative effects. Each disc is 1/2" in diameter.

NUMBER	DESCRIPTION	EACH	12/EA
A30319-0100	Klay Gun with 19 Discs	\$19.65	\$17.69
A30319-0000	19 Replacement Discs	5.25	4.73



Garlic Press

Children love making "hair" for their clay figures, and a garlic press makes a fun, easy extruder for creating strands of all types of clay. This solid aluminum garlic press is long-wearing for years of use.

NUMBER	EACH	12/EA
A61422-1010	\$6.67	\$5.99



Amaco® Polymer Clay and Craft Oven

Use this handy countertop oven for baking polymer clays or for craft projects that require heat up to 300°F (149°C). It has a 30-minute timer to prevent overbaking. Capacity is 540 cubic inches. Operates on standard household current. Includes one-year limited warranty. cUL listed.

NUMBER	EACH
A33900-1001	\$83.18



Midwest Products® Basswood Carving Blocks

A very fine and light carving wood. Soft, closed grain makes it easy for cutting, sanding, and finishing. Takes paint and stain very well.

NUMBER	SIZE	EACH	12/EA
A33302-8502	2" x 2" x 12"	\$9.31	\$8.38
A33302-8503	2" x 3" x 12"	12.22	10.99
A33302-8504	2" x 4" x 12"	13.98	12.58



Wood Blocks

These 1/4" thick laminated (plywood) blocks — either Philippine mahogany or white wood — are ideal for woodcut printing, carved plaques, or woodburning. Each package contains 12 pieces.

NUMBER	DESCRIPTION	SIZE	EACH	6/EA
A42902-1001	Mahogany	6" x 8"	\$12.12	\$10.90
A42902-1003	Mahogany	8" x 12"	17.57	15.80
A42902-1006	Mahogany	12" x 16"	28.78	25.89
A42902-1011	White	6" x 8"	16.49	14.83
A42902-1002	White	8" x 12"	26.97	24.26
A42902-1016	White	12" x 16"	51.30	46.13



3M® Production Sandpaper

For all your sanding needs! Available in four different grit types, these professional-quality sandpaper sheets measure 9" x 11". For 10-sheet packs, visit DickBlick.com.

NUMBER	DESCRIPTION	GRIT	EACH	10/EA
A34916-1303	Fine	120	\$8.18	\$7.34
A34916-1403	Medium	80	8.58	7.70
A34916-1003	Coarse	50	9.55	8.56

Norton Sandpaper

Economical and durable, for hand or machine use on wood, metal, plastic, and fiberglass. Extra Fine to Extra Coarse grades.

Package of 25 Sheets — 9" x 11".

NUMBER	DESCRIPTION	GRIT	EACH	10/EA
A34935-1013	Extra Fine	220	\$15.61	\$14.06
A34935-1023	Fine	150	24.06	21.66
A34935-1033	Medium	100	24.06	21.66
A34935-1043	Coarse	80	26.91	24.23
A34935-1053	Extra Coarse	50	34.83	31.35

Assorted Pack of 25 — 9" x 11".

NUMBER	EACH	10/EA
A34935-0069	\$25.65	\$23.09



Student Wood Chisel Set

Economically priced, scholastic-grade assorted cutters and knives for relief carving, wood block, and linoleum block printing. Smooth wood handles. Set of 12 tools, each 5-3/4" long.

NUMBER	EACH	12/EA
A33005-1009	\$14.11	\$12.68



Coping Saw

This coping saw is perfect for cutting plastic, cardboard, Styrofoam, metal, and intricate wood cutouts. It has an adjustable wooden handle that holds blades taut for positive control. Includes four assorted 6-1/2" long blades. Saw measures 7" long with a 4-1/2" deep throat. Replacement blade set includes four blades.

NUMBER	DESCRIPTION	EACH	12/EA
A34933-1745	Saw	\$16.25	\$14.62
A34933-1012	Replacement Blades	4.30	3.87

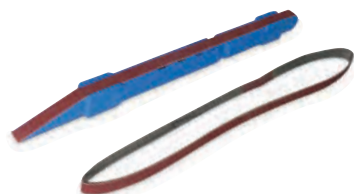

Excel® Sanding Stick

Perfect for sanding hard-to-reach places, the Excel Sanding Stick can be used for sanding wood, plus deburring, grinding, shaping, and finishing other materials. It's made from high-impact plastic with spring-tensioned technology that allows the aluminum oxide sanding belt to stay in place. The design allows for full control and rotation, so all areas of the belt may be used. A tapered end permits easy access for detailing.

Stick with 2 Extra Sanding Belts

NUMBER	DESCRIPTION	EACH	6/EA
A34369-1024	#240 Grit	\$8.72	\$7.84
A34369-1032	#320 Grit	8.72	7.84
A34369-1040	#400 Grit	8.72	7.84

Pack of 5 Replacement Belts

NUMBER	DESCRIPTION	EACH	6/EA
A34369-1124	#240 Grit	\$12.65	\$11.39
A34369-1132	#320 Grit	12.65	11.39
A34369-1140	#400 Grit	12.65	11.39



Art Alternatives™ Sanding Blocks

Ideal for a variety of sanding needs — from resurfacing and paint removal to final finishing and creating artistic effects — these versatile sanding blocks are made of polyurethane foam, and coated with long-lasting grit. Use wet or dry. Each offers two grit types.

NUMBER	DESCRIPTION	EACH	12/EA
A34224-1001	Fine/Medium Grit	\$3.60	\$3.24
A34224-1002	Medium/Coarse Grit	3.60	3.24

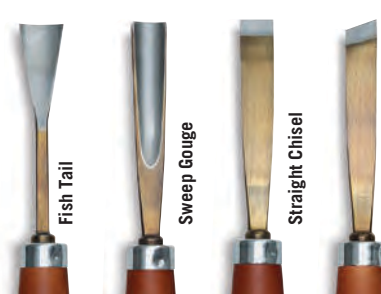

Sculpture House® Individual Wood Carving Tools

These full-size, leather-tipped percussion hand tools have been forged from the finest-quality high-carbon steel and tempered by an oil temper and heat-treating method for toughness. The tools are batch-tested with a Rockwell black diamond steel hardness test machine that has been factory calibrated to ensure the highest-quality carving tools in the world.

NUMBER	DESCRIPTION	SIZE	EACH	6/EA
A33078-1003	#1 Skew Chisel	3/4"	\$30.57	\$27.51
A33078-1004	#2 Straight Chisel	3/4"	30.57	27.51
A33078-1002	#7 Sweep Gouge	3/4"	39.30	35.37
A33078-1001	#54 Fish Tail	1/2"	41.49	37.34



Carving Chisel Set

An essential selection of chisels and gouges for the woodworker. Set includes eight carving knives with ball-shaped solid wood handles, two rasps, two bench oil stones for precise tool sharpening and honing, and a black fabric case that keeps tools protected when not in use.

NUMBER	EACH	12/EA
A33093-1009	\$90.54	\$81.47



Sculpture House® Wood Carving Set

An inexpensive, high-quality set for wood carving, wood block, and linoleum block printing. Set includes long bent gouge, short bent gouge, straight gouge, parting tool, skew chisel, and straight chisel. Comes in a cardboard box.

NUMBER	EACH
A33002-1009	\$50.22



Sculpture House® Wood Carving Mallets

One-piece solid wood mallets designed for light to medium wood carving. Comfortable handles are completely wax-coated to deter possible checking.

NUMBER	DESCRIPTION	EACH
A33071-1002	Cutting Knife	\$20.74
A33071-1001	Detail Knife	23.99



Sculpture House® Wood and Linoleum Carving Kit

A wood-handled five-piece tool set for hand-carving wood or linoleum. It includes a straight gouge, short bent, parting chisel, skew chisel, and straight chisel.

NUMBER	EACH	3/EA
A34203-1009	\$64.69	\$58.22



Palm-Grip Carvers

Very fine quality, forged, heat-treated steel blades set in smoothly finished 4-3/4" palm-grip wood handles. Popular for relief carving on wood or linoleum. Six-piece set contains knife, chisel, gouge, shallow U gouge, veiner, and sharpening stone.

NUMBER	EACH	12/EA
A33004-1009	\$54.25	\$48.83



Flexcut® Knives

Ash-handled high carbon steel knives are easily maintained by simple stropping. General-purpose Cutting Knife has a 1-1/8" blade and rounded point, great for beginners. Detail Knife has a 1-1/2" straight blade with a very fine point for making narrow detailing cuts. Pelican Knife has a curved 1-5/8" blade similar to a skew, with a narrowed point. Mini-Pelican is a 7/8" ultra-thin blade for fine cutting.

NUMBER	DESCRIPTION	EACH
A33096-1001	Cutting Knife	\$23.91
A33096-1002	Detail Knife	25.05
A33096-1003	Pelican Knife	29.43
A33096-1009	4 Knife Set w/roll	99.16

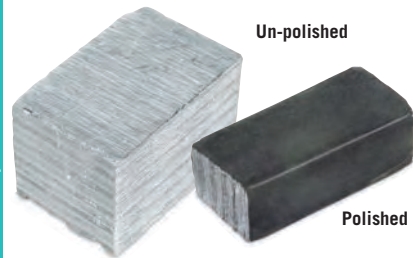

Sculpture House® Soapstone

One of the most enjoyable soft stones to work with, soapstone is easy to carve with small hand tools. It contains no asbestos and finishes to a high gloss with minimum effort. Sea Mist Green color. Sizes are approximate.

NUMBER	WEIGHT	APPROX. SIZE	EACH	12/EA
A33119-7302	2 lb	4" x 4" x 2"	\$8.73	\$7.86
A33119-7304	4 lb	5" x 4" x 3"	16.37	14.74
A33119-7308	8 lb	4" x 6" x 4"	31.65	28.50
A33119-7310	10 lb	6" x 7" x 3"	39.29	35.38
A33119-7320	20 lb	9" x 6" x 4"	78.58	70.75

Class Pack #1 — Five 2 lb pieces, each approximately 4" x 4" x 2".

NUMBER	EACH	12/EA
A33602-1002	\$43.67	\$39.30

Class Pack #2 — Four 4 lb pieces, each approximately 5" x 4" x 3".

NUMBER	EACH	12/EA
A33602-1004	\$70.69	\$63.62



Sculpture House® Translucent White Alabaster

These rough-cut stones are hand-picked and imported from Italy. A very pure stone with rarely an imperfection, it's easy to carve, and can be rubbed to a matte or gloss finish. Medium hardness, translucent, clear white color with very light veining. Light will filter softly through thin areas of this stone. Contains no asbestos.

NUMBER	WEIGHT	APPROX. SIZE	EACH	12/EA
A33109-1007	2 lb	4" x 4" x 2"	\$8.19	\$7.37
A33109-1004	4 lb	5" x 4" x 3"	16.38	14.74
A33109-1008	8 lb	4" x 6" x 4"	31.66	28.50
A33109-1000	10 lb	6" x 7" x 3"	39.31	35.38
A33109-1020	20 lb	9" x 6" x 4"	78.61	70.76



Sculpture House® Opaque White Alabaster

A beautiful, rough cut stone for carving, White Alabaster is imported from Italy. Note: All have minor chips and flaws inherent in natural stone products. **Block** — Eliminates the work required to reduce a boulder or slab into a workable piece of stone.

NUMBER	APPROX. SIZE	EACH	6/EA
A33604-1023	2" x 3" x 3"	\$9.82	\$8.83
A33604-1026	2" x 3" x 6"	16.37	14.72
A33604-3504	4" L x 3-1/2" Dia	23.99	21.62
A33604-9048	8" L x 4" Dia	30.57	27.51
A33604-9066	6" L x 6" Dia	45.86	41.27



A-E Sculpture House® Stone Carving Chisels

Hand-forged of finest steel, tempered for marble and limestone. Because they are forged, sizes are approximate.

NUMBER	DESCRIPTION	EACH	6/EA
A33037-1100 A	3/4" Tooth, Small Tip	\$22.92	\$20.63
A33037-1005 B	1" Tooth, Medium Tip	23.99	21.61
A33037-0025 C	1/4" Point Tip	22.92	20.63
A33037-1063 D	5/8" Flat, Small Tip	21.83	19.65
A33037-1003 E	3/4" Flat, Medium Tip	23.99	21.61



F Sculpture House® Stone Carving Hammers

Soft iron carving hammers with smoothly finished wood handles for stone carving and sculpture.

NUMBER	SIZE	EACH	6/EA
A33008-1006	1-1/2 lb	\$52.41	\$47.17
A33008-1007	2-1/2 lb	85.67	77.10

G Sculpture House® Stone Carving Sand Bag

This American-made sandbag is crafted of heavy-duty double-stitched canvas that can handle the toughest treatment. One end of the 12" x 10" bag is unstitched. Sand is not included.

NUMBER	EACH	6/EA
A34966-1001	\$17.46	\$15.72



Sculpture House® Stone Carving Starter Set

This set has everything the novice stone carver needs for carving, sanding, and hand-polishing soapstone, one of the most popular stones for carving both jewelry and display pieces. It includes one piece of soapstone, a rasp, a carving knife, polishing oil, a dust mask, and an idea guide.

NUMBER	EACH	6/EA
A34936-1030	\$41.25	\$37.12



H Sculpture House® 6-Piece Stone Tool Set

2-3/8" x 1-1/2" hammer with 1-1/2" x 1-3/8" face and five basic carving tools forged of finest steel, tempered for limestone and marble cutting.

NUMBER	EACH
A33026-0000	\$119.54

I Sculpture House® Miniature Stone Tools

A necessity for amateurs and professionals alike, this 8-piece set of handmade, high-carbon steel tools is ideal for detail and miniature work. It includes five chisels, two rasps, and a hammer, all contained in a canvas roll. Average tool length is 7-1/2".

NUMBER	EACH
A33007-1008	\$192.35

J Sculpture House® Professional Stone Tool Set

These steel tools are forged and tempered for marble, limestone, and sandstone. The set includes nine chisels, two points, a rasp, and a 2-1/2 lb hammer in a canvas roll-up pouch.

NUMBER	EACH
A33009-1013	\$317.00

K Sculpture House® Soapstone Carving Set

Designed specifically for carving soapstone, this high-quality set includes four cutting tools, one rasp, and sandpaper sheets, all contained in a protective canvas roll. Made in the USA.

NUMBER	EACH	6/EA
A34213-1009	\$78.61	\$70.75



Sculpture Block® Sculpture Canvas®

Artists of all ages and experience levels will enjoy creating detailed 3-D paintings on Sculpture Canvas. Made from an extremely strong yet easy-to-carve material, images drawn on these 1.2" thick "canvases" are best shaped with rounded chisels. Details can be refined (or a smooth finish created) using rifflers, rasps, or sandpaper. Coat the painting with an acrylic binder or gesso, then paint it with acrylics or oils and embellish as desired. Low dust, non-toxic, and environmentally friendly.

NUMBER	SIZE	EACH	10/EA
A34341-1009	7" x 9"	\$13.90	\$12.52
A34341-1023	9" x 12"	17.31	15.59
A34341-1012	12" x 12"	21.99	19.77
A34341-1006	12" x 16"	32.75	29.47



Sculpture Block®

Create beautiful, detailed sculptures in less time and for less money with Sculpture Block. Extremely light and strong, this user-friendly material is also more cost-effective than wood or stone. Ideal for professional artists, 3-D designers, hobbyists, architects, and modelmakers, it can be shaped with saws, round chisels, rasps, or sandpaper. It can also be glued, painted, decorated, or coated with plaster, cement, polyester, or epoxy. Low dust, non-toxic, and environmentally friendly.

NUMBER	DESCRIPTION	SIZE	EACH	8/EA
A34323-1002	Pack of 3	6" x 6" x 2"	\$24.29	\$21.83
A34323-1003	Single Pack	6" x 6" x 3"	19.65	17.68
A34323-1001	Single Pack	6" x 3" x 2"	8.73	7.85
A34323-1006	Single Pack	6" x 6" x 6"	24.29	21.83
A34323-1004	Single Pack	12" x 6" x 4"	31.63	28.46



Xiem™ Studio Sgraffito and Detailing Set

This set of seven double-ended, handcrafted tools gives artists 14 of the most practical and versatile tools for sgraffito and detailing. Made from high-grade stainless steel, every tool has two precise cutting edges, plus rubber handles for a comfortable, secure grip. Use them for scratching through a clay surface to reveal a contrasting color, or for scratching into slip before firing. They're also great for intricate carving, cutting, and for refining details.

NUMBER	EACH
A34034-1079	\$35.25



FloraCraft® Carving Foam

Lightweight and easy to work with, FloraCraft Carving Foam is neutral brown/gray in color, with a smooth, fine texture that carves like soft wood. It won't crack, split, or check, and pieces can be bonded together. It has a density of 1.6 lb per cubic foot.

NUMBER	SIZE	EACH	12/EA
A33676-1008	3" x 4" x 8"	\$4.21	\$3.79
A33676-1003	3" x 4" x 12"	5.33	4.80
A33676-1004	4" x 6" x 12"	7.99	7.22
A33676-1006	6" x 6" x 6"	6.89	6.21
A33676-1012	12" x 12" x 12"	58.77	52.89



FloraCraft® Styrofoam™ Blocks

These pure white, feather-light blocks are easy to handle, easy to decorate, and great for craft and sculpture projects.

NUMBER	SIZE	EACH	12/EA
A60928-1009	1" x 6" x 12"	\$3.08	\$2.77
A60928-1010	1" x 12" x 10"	4.81	4.32
A60928-1011	1" x 4" x 10"	1.99	1.80
A60928-1012	2" x 4" x 12"	3.95	3.56



Sculpture House® Microcrystalline Wax

Soft, nut brown, for direct modeling or pulling waxes for bronze investment jewelry casting. Highly refined.

NUMBER	SIZE	EACH	12/EA
A33115-1006	1 lb	\$23.99	\$21.61
A33115-1010	10 lb	177.38	160.76



Sculpture House® Tabletop Revolving Sculpture Stand

Waterproof wood makes this space-saving stand ideal for checking students' clay, wood, and stone pieces during the creation process, or for displaying finished works. The top revolves to reveal all facets of a piece. Rugged five-ply construction, non-slip base. The stand is 12" square, with a natural finish.

NUMBER	EACH	6/EA
A34932-1012	\$65.51	\$58.96



Blick® Carving Foam

A great media for beginning, intermediate, and even advanced sculptors, Blick Carving Foam is a lightweight yet strong sculpting material that is easier to carve than similar products, and more economical than wood or stone. Even fine details can be captured with carving tools such as chisels, saws, rasps, and sandpaper. It also accepts paint and glue, making it ideal for model-making. Its light color makes drawn designs stand out. 5 lb per cubic foot density.

NUMBER	DESCRIPTION	SIZE	EACH	6/EA
A34382-1001	36 pieces	6" x 4-1/2" x 1"	\$103.52	\$93.17
A34382-1002	36 pieces	6" x 3" x 2"	111.92	100.73



Sculpture Block® Starter Tool Set

Create beautiful, detailed sculptures with the Sculpture Block Starter Tool Set. The rasp and scraper are designed for shaping, and the sandpaper should be used for finishing. The set also includes a dust mask, which should always be used when sanding.

NUMBER	EACH	6/EA
A35146-1049	\$16.37	\$14.73



Sculpture Stand

This four-legged steel floor stand is built to handle heavy work, making it an ideal choice for schools and studios. Leg spread at the base is 20". Legs are connected to a center shaft that allows for vertical adjustment of the durable 15-3/4" Sqr melamine top from 35" to 45" high. Casters provide mobility and lock for stability. Weighs 30 lb.

NUMBER	EACH
A33081-1001	\$318.00



Sculpture House 7-Piece Steel Rasp Set

This set of seven rasps is made for fine detail work on stone. It includes R49, R54, R55, R66, R67, R72, and R78 rasps. Each tool measures approximately 6" long.

NUMBER	EACH	4/EA
A33088-1007	\$212.93	\$191.64



Sculpture House Quality Rasps

Imported from Italy, each of these fine-cut rasps is individually manufactured by hand. The teeth are easily cleaned out, making these great sculpture tools. Each rasp has an octagon-shaped, smoothly finished wooden handle. Note: The length is the measured length of the blade, not including the handle.

NUMBER	DESCRIPTION	EACH	12/EA
A33028-1008	8" Coarse	\$28.38	\$25.56
A33028-1001	10" Medium	28.38	25.56
A33028-1012	12" Coarse	34.93	31.46

Round NUMBER	SIZE	EACH	12/EA
A33030-1006	6"	\$19.65	\$17.68
A33030-1008	8"	23.58	21.22



Kemper Ceramic Loop Tools

Spring-tempered steel shapes set in thick, tapered handles. Use them to trim or refine the shape and control the wall thickness on greenware. Approximately 5" long.

NUMBER	DESCRIPTION	EACH	12/EA
A30328-1205	Triangle	\$5.23	\$4.70
A30328-1005	Round	4.97	4.47
A30328-1105	Pear	4.97	4.47

Set of 3 — Includes one of each style.

NUMBER	EACH	6/EA
A30331-1009	\$9.82	\$8.83



Mini Ribbon Tool Set

These handy tools are used for fine sculpting, detailing, and trimming when working with clay, greenware, plaster, wax, bread dough, or any modeling medium. The set contains six tools, each measuring approximately 5" long.

NUMBER	EACH	6/EA
A30397-9339	\$11.41	\$8.67



Wire End Clay Tool Set

Every tool in this set is hand-wound to ensure firmness and durability. The set of six double-ended tools with boxwood handles includes 12 useful shapes. Tools measure 8" long.

NUMBER	EACH	6/EA
A30306-1009	\$11.99	\$10.80



Ribbon Tool Set

These tools serve a multitude of purposes for the ceramist and sculptor, such as trimming and footing of pottery. The set includes five double-ended tools with lacquered wood handles and metal ferrules. Each measures 7-1/2" long.

NUMBER	EACH	6/EA
A30356-1009	\$19.26	\$17.33



Kemper Ribbon Tools

Flat, ribbon-like, clockspring steel is used to form the cutting heads on these tools. They provide a variety of shapes for light cutting and trimming of clay, greenware, plaster, and more. Wooden handles with brass ferrules. Approximately 6" long.

NUMBER	DESCRIPTION	EACH	6/EA
A30330-1006	R1	\$5.10	\$4.59
A30330-1106	R2	5.10	4.59
A30330-1206	R3	5.10	4.59
A30330-1306	R4	5.10	4.59
A30330-1406	R5	5.10	4.59



Xiem Sculptor's Wire Tool Set

Xiem Sculptor's Wire Tools allow artists the freedom to customize and combine their favorite wire tool tips by simply inserting different tips into the tools. Available with small, medium, and large size wire tips, the tools are ideal for light cutting, smoothing, cleaning, and blending on wax, modeling clay, self-hardening clay, oil-based clay, and moist clay. The tips are made from high-strength stainless steel for long-lasting performance. The tools feature soft silicone handles.

NUMBER	DESCRIPTION	SIZE	EACH	6/EA
A34371-1009	8-piece set	Small	\$23.10	\$20.79
A34371-1019	8-piece set	Medium	23.10	20.79
A34371-1029	6-piece set	Large	29.75	26.78



Xiem Mini Ribbon Tool Set

Ribbon blades are made of fine tempered steel, affixed to aluminum handles with soft neon rubber grips. Set of nine includes every mini ribbon tool Xiem offers.

NUMBER	EACH	6/EA
A17339-1009	\$26.40	\$23.75



Xiem Studio Carving Tool Set

Xiem tools are great for delicate carving and adding details to soft clay. Handcrafted from high-quality stainless steel to ensure a precise cutting edge, each tool is fitted with a rubber grip for secure, comfortable handling. The bright orange grips make the tools easy to find in the studio. Set of four.

NUMBER	EACH	6/EA
A35038-1009	\$31.95	\$28.75



Richeson Double Wire End Tool Set

This canister is loaded with a total of 60 double-ended tools representing 12 different wire end shapes. Great for cutting and slicing as well as removing amounts of clay.

NUMBER	EACH	6/EA
A30300-1009	\$110.64	\$99.57



Kemper Wire Loop Sgraffito Tool

The small wire loops on each end of this tool enable a method of sgraffito in which smooth variations of line width can be made within a single stroke. Extremely useful when adding impressions and decorations to the clay piece before baking. 6-1/4" long, with a hardwood handle.

NUMBER	EACH	12/EA
A30317-1063	\$4.70	\$4.23



Sculpture House Sgraffito and Clean-Up Tool Set

Each of these three tools has double working ends for double the versatility. The high-quality metal ends are mounted on lacquered hardwood handles with brass ferrules and waterproof glue. Great for detailing, sgraffito, and finishing. Average length is 7-1/2".

NUMBER	EACH	12/EA
A30310-1009	\$22.87	\$20.58



Kemper Ceramic Set

Set of seven popular and practical tools for ceramics: wire loop sgraffito, cutting tool, palette knife, clean-up tool, lace tool, sabre saw, and salt and pepper drill. Packaged in a plastic tray.

NUMBER	EACH	12/EA
A30329-1009	\$32.95	\$29.65



Kemper Hole Cutters

Sharp, polished hole cutters provide an easy method for cutting clean holes in wet, thick-walled greenware and clay. Can also be used for creating designs.

NUMBER	HOLE SIZE	OVERALL LENGTH	EACH	12/EA
A30369-4012	1/2"	6-1/2"	\$6.03	\$5.43
A30369-4014	1/4"	5-5/8"	5.48	4.90
A30369-4316	3/16"	5-3/4"	5.37	4.84



Xiem Needle Tools

Xiem Needle Tools are made from a solid piece of surgical stainless steel for sharpness and longevity, set in faceted, rubber, non-roll handles. Stoneware Needle Tool is for use with coarse clay. Porcelain Needle Tool is for delicate cuts on fine porcelain. Handle color may vary.

NUMBER	DESCRIPTION	EACH	12/EA
A30995-1001	Porcelain	\$7.05	\$6.35
A30995-1101	Stoneware	7.05	6.35

Pro Needle Tool

This large, sharp needle is firmly set in an aluminum handle, which is finely textured to provide a firm grip for wet hands. May be used to cut heavy clay strips, cut designs in clay, or make holes. Great for piercing the first primary hole in beads. 6-1/8" long.

NUMBER	EACH	6/EA
A34920-1063	\$3.98	\$3.54

Kemper Straight Needle

For sgraffito and delicate lace decoration. Needle is 5" long. Polished wood handle.

NUMBER	EACH	12/EA
A30308-1005	\$2.27	\$1.95



Kemper Double Ball Stylus Embossing Tools

Excellent for sgraffito, embossing, and tole painting. Use with polymer clay for drawing smooth lines and decorations before baking. Each ball end is made of stainless steel, treated for hardness, and set in a smooth hardwood handle. Approximately 5-1/2" long. Small: .03/.045; Regular: .045/.072.

NUMBER	DESCRIPTION	EACH	12/EA
A30316-0100	Small	\$4.21	\$3.79
A30316-0000	Regular	4.09	3.67



Richeson Boxwood Tool Canister

Convenient clear canister with lid holds 69 clay modeling tools in a variety of shapes. The canister contains wire end and wood tools, ribbon end and wood tools, straight needles, clean-up and lace tools with double working ends, salt and pepper drill, and brush tool. This set is great for intricate work, smoothing edges, finishing, trimming, and adding detail.

NUMBER	EACH	6/EA
A30343-0699	\$149.90	\$134.94



Kemper Fetting Knives

Use these knives to trim, carve, remove mold marks, and sculpt ceramics and greenware. The softer steel blade is flexible enough to bend; the harder is a tempered steel blade with the same feel as other conventional blades. Blades are 4" long; 8" total length.

NUMBER	DESCRIPTION	EACH	12/EA
A30349-1010	Soft	\$6.15	\$5.50
A30349-1020	Hard	6.15	5.50



Double Ended Clay Shapers

These highly versatile, brush-like tools have a flexible silicone tip that resists heat and solvents and allows expressive work and exceptional control. Steel ribbon tools on the other end. Easy to clean.

NUMBER	DESCRIPTION	EACH	6/EA
A30350-1000	0 Flat Chisel	\$10.51	\$9.46
A30350-2000	0 Taper Point	10.51	9.46
A30350-1002	2 Flat Chisel	11.86	10.67
A30350-2002	2 Taper Point	11.86	10.67
A30350-1006	6 Flat Chisel	13.53	12.18
A30350-2006	6 Taper Point	13.53	12.18
A30350-1010	10 Flat Chisel	17.35	15.62
A30350-2010	10 Taper Point	17.35	15.62



Kemper Wipe Out Tool

Sure to become one of your favorites with its double-ended, rubber-tipped design and durable wood barrel. Great for smoothing surfaces on clay projects, it can also be used for cleanup around engraved designs. For use on non-porous surfaces only. 6-1/8" long.

NUMBER	EACH	6/EA
A30312-1062	\$8.03	\$7.23



Clay Shaper Sets

Each set includes five tip shapes as shown. (Not double-ended.)

NUMBER	DESCRIPTION	DIA.	EACH	6/EA
A30303-1009	Size 2, Small	3/16"	\$45.35	\$40.82
A30303-1019	Size 6, Regular	5/16"	64.20	57.78



Student Modeling Tool Canisters

Four times stronger than wood. Includes seven of the most popular shaping tools and 14 creative edges. Use with clay, plaster, and air-dry materials, or copper and aluminum tooling foil. 6" long.

NUMBER	EACH	12/EA
A30361-1009	\$4.66	\$4.33

Set of 35 — Includes five each of seven different tools.

NUMBER	EACH	6/EA
A30387-1035	\$23.07	\$20.75

Set of 140 — Includes 20 each of seven different tools.

NUMBER	EACH	6/EA
A30387-1001	\$61.04	\$54.91



Boxwood Clay Double-Ended Tool Sets

Handmade of fine-quality birch and hand-polished to a beautiful finish. For fine shaping and finishing work. Professional or student use.

Set of 10 (shown)

NUMBER	LENGTH	EACH	6/EA
A30304-1069	6"	\$9.82	\$8.83
A30304-1089	8"	10.91	9.81

Set of 38 — 76 shapes in all. 6" long.

NUMBER	EACH	6/EA
A30304-1009	\$36.68	\$32.99



Sculpture House® Duron

Plastic Tool Set

A set of 12 durable, flexible plastic tools, three times stronger than wood. From 6" to 8" long.

NUMBER	EACH	6/EA
A30322-1009	\$12.55	\$11.29



Richeson® Clay Modeling Tools

This convenient canister holds 72 boxwood modeling tools in an assortment of 8" shapes. Each tool is contoured for easy handling with two different ends for shaping and finishing work, on and off the wheel.

NUMBER	EACH	6/EA
A30342-0729	\$61.93	\$55.73



Activa® Activ-Tools™ Clay Tools

This set of essential clay tools includes four easy-to-use tools for beginners and professionals alike. Each tool enables artists to cut, sculpt, shape, embellish, texture, scribe, and add fine details to most modeling media. The set includes a rough cut blade, a needle point, a smooth cut blade, and a roller cutter. The tools are dishwasher-safe.

NUMBER	EACH
A35143-1049	\$6.54



Kemper® Rubber Finishing Tool

Molded from pliable rubber in a kidney shape. Use for smoothing, shaping, and finishing pieces. 3-1/8" long.

NUMBER	STYLE	EACH	12/EA
A30314-0000	Soft	\$3.15	\$2.83
A30314-1318	Hard	3.50	3.15

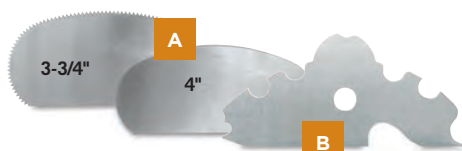

A Kemper® Scrapers

Shape, smooth, and trim pottery shapes with these scrapers made from flexible spring stainless steel. The rigid scrapers can also be used as a squeegee to remove excess water from pottery shapes. Note — These products have sharp edges and should be used with caution, which might include using protective gloves. Not recommended for use by children.

NUMBER	SIZE	EACH	10/EA
A30334-1004	4" Smooth	\$2.16	\$1.85
A30334-1003	3-3/4" Toothed	2.53	2.12

B The Ultimate Edger

This stainless steel edger allows you to add perfect edges to your clay pots. Many cuts and curves allow you to make the perfect shape with just one tool. 4-1/4"L x 2"H.

NUMBER	EACH	12/EA
A30367-1000	\$14.83	\$13.35



Xiem™ Studio Modeling and Carving Tool Set

All the right tools for your modeling and carving needs, and a fantastic addition to your Xiem tool bag! Each double-ended tool is made from high-grade solid stainless steel and handcrafted with essential shapes and contours for intricate modeling, carving, shaping, and clay removal. The bright red rubber grips ensure a secure hold and help make your tools easy to find. These tools can be sharpened and are made to last a lifetime. Set includes nine tools.

NUMBER	EACH	6/EA
A17340-0909	\$40.75	\$36.69

Potter's Ribs

Beautifully formed and polished boxwood tools for shaping clay while working on the wheel.

NUMBER	DESCRIPTION	EACH	12/EA
A30358-1006	#6 Quarter Rectangle	\$4.24	\$3.81
A30358-1007	#7 Quarter Oval	4.24	3.81
A30358-1008	#8 Quarter Oval	4.24	3.81



5-Piece Potter's Rib Set

Made from beautifully formed, smooth finished boxwood, this set includes the basic shapes for opening, shaping, curving, smoothing, and trimming wet clay on the potter's wheel. Shapes range from 4" to 7-1/2" long.

NUMBER	EACH	6/EA
A30358-1009	\$11.60	\$10.45



Xiem™ Silicone Ribs

Xiem Ribs are classic, essential tools for all clay work, including throwing, hand-building, shaping, and smoothing. More flexible and versatile than wood ribs, they're made from silicone that is resistant to heat, solvents, stains, and cracks. Choose large or small, soft or firm. Clean with soap and water. Blot to dry.

NUMBER	DESCRIPTION	SIZE	EACH	12/EA
A30987-1001	Soft	2.2"W x 4.3"L x 1/4"D	\$5.46	\$4.91
A30987-1002	Firm	2.2"W x 4.3"L x 1/4"D	5.46	4.91
A30987-1003	Soft	1.6"W x 2.9"L x 1/4"D	5.46	4.91
A30987-1004	Firm	1.6"W x 2.9"L x 1/4"D	5.46	4.91



Set A — Flex Soft



Set B — Flex Firm

Set C — Flex Soft

Xiem™ Studio Decorating Rib Sets

The ultimate clay decorating tools, each set contains four ribs, with three patterns on each. Create texture on any malleable surface, including clay, thick slip, underglaze, engobe, icing, thick paint, gel mediums, glue, plaster, and putty. To clean, simply wash with soap and water, then blot dry.

NUMBER	DESCRIPTION	EACH	12/EA
A31150-1003	Set A, Flex Soft	\$15.38	\$13.85
A31150-1006	Set B, Flex Soft	15.38	13.85
A31150-1004	Set C, Flex Soft	15.38	13.85
A31150-1005	Set A, Flex Firm	15.38	13.85
A31150-1001	Set B, Flex Firm	15.38	13.85
A31150-1002	Set C, Flex Firm	15.38	13.85



Medium Texture

Smooth Texture

Fine Texture

Xiem™ Studio Pro-Sponges

Extremely soft, super-absorbent, and long-lasting, these chamois sponges have tapered edges that lend fine control when working with either porcelain or stoneware clay. The finishing sponge can be used to make surface refinements on any clay body.

Medium Texture for Stoneware Clay

NUMBER	EACH	12/EA
A30276-1001	\$4.36	\$3.92

Fine Texture for Porcelain Clay

NUMBER	EACH	12/EA
A30276-1102	\$4.36	\$3.92

Smooth Texture for Surface Finishing

NUMBER	EACH	12/EA
A30276-1203	\$4.36	\$3.92



Xiem™ Studio X-Sponge 2™

Not an ordinary "sponge-on-a-stick." Its stainless steel rod telescopes from 8-1/2" to 26" long, for removing water from the bottom of both shallow and deep pots. The soft, comfortable rubber handle lends a secure grip.

NUMBER	DESCRIPTION	EACH	12/EA
A30277-1001	Tool	\$13.18	\$11.86
A30277-1002	Replacement Sponges, Set of 2	8.45	7.61



Xiem™ Double Ended Trimming Tool Set

This set includes three double-ended clay trimming tools — six precision tools in all. The blades are handcrafted from high-grade tempered stainless steel, attached to yellow rubber handles for a secure grip. Each tool measures 6-1/4" long and can be sharpened.

NUMBER	EACH
A30997-1039	\$36.35



Turning Tool Set

Turn down clay on the wheel with these steel turning tools. Add stunning detail to your next clay project. Three-pack set includes teardrop, triangle, and four-sided box shapes. 8" long wooden handle provides superb control.

NUMBER	EACH	6/EA
A30362-1009	\$21.39	\$19.25

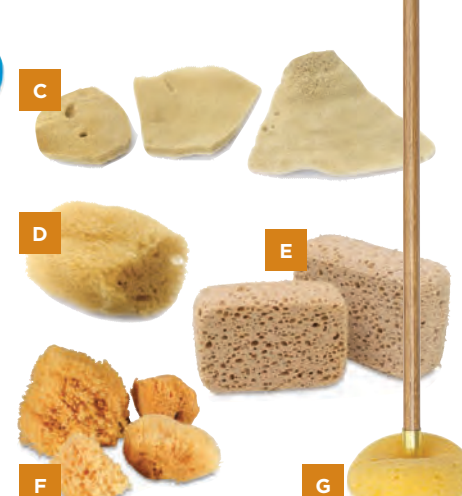

C-F Sponges

C Elephant Ear Sponges — These flat, absorbent, natural sponges have a fine texture. Used to carefully moisten and smooth the pottery surface.

NUMBER	STYLE	APPROX.	EACH	12/EA
A32904-1025	#2	2-1/2"-3"	\$2.09	\$1.89
A32904-0000	#3	3"-3-1/2"	4.19	3.77
A32904-1004	#5	4"-4-1/2"	8.05	7.25

D White Silk Sponge — Potter's texture tool with an open texture for stippling. Highly absorbent, with tiny, refined pores. Approximately 2-1/2"-3".

NUMBER	EACH	12/EA
A32904-0100	\$2.53	\$2.29

E Oval Poly Sponge — Soft and absorbent. Chemical- and grease-resistant.

NUMBER	APPROX.	EACH	12/EA
A32902-1001	6" x 4" x 2-1/2"	\$2.42	\$2.18
A32902-1000	5" x 3" x 2"	1.64	1.48

F Super Value Sponge Set — Set of four includes one silk, one yellow, one wool, and a free jumbo.

NUMBER	EACH	12/EA
A32934-0009	\$5.85	\$5.25

G Kemper® Sponge Holder

13" long hardwood handle with attaching screw and cup washer holds your favorite sponge so you can reach the bottom and inside walls of deep pots. (Poly sponge included.)

NUMBER	DESCRIPTION	EACH	12/EA
A32925-0000	Holder & Sponge	\$7.70	\$6.92
A32925-0100	Replacement Sponge	1.45	1.30



Xiem™ Studio X-Bevel Clay Cutter

Designed for quick and precise cutting of clay at 45°, 30°, and 60° angles, this is an essential hand-building tool for potters. The X-Bevel is made of natural wood to fit comfortably in the hand. The cutting wire is made of stainless steel.

NUMBER	EACH	12/EA
A31128-1001	\$9.65	\$8.69



Wood Paddles

Use these thick Baltic birch paddles for shaping, hammering, and forming. Flat or rope finish with 1/4" hollow braid polypropylene rope attached.

NUMBER	DESCRIPTION	EACH	6/EA
A30347-1010	Flat 12" x 4" x 7/16"	\$10.36	\$9.32
A30347-1020	Rope 12" x 2" x 1/2"	11.84	10.65

Amaco® Adjustable Clay Slicer

Amaco's Adjustable Clay Slicer makes cutting slabs, tiles, or extrusions quick and easy. A heavy-duty stainless steel wire is securely attached on both sides to a sturdy metal handle, ensuring accurate cuts. The guide bar adjusts up or down to create slabs from 3/8" to 3-1/8" thick (in 1/4" increments), and up to 7" wide.

NUMBER	EACH	12/EA
A31126-1007	\$17.19	\$15.47

Nylon Clay Cutter

Ideal for slicing and cutting lump clay, as well as trimming pots and other projects on the wheel. Hardwood 3" toggle handles are firmly fastened to approximately 18" of high-strength braided nylon. More durable than a wire cutter, the nylon will not rust or discolor.

NUMBER	EACH	12/EA
A30357-0000	\$1.76	\$1.19

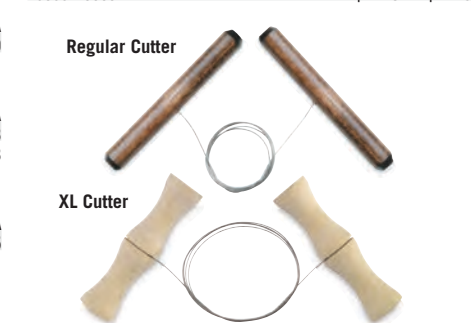

Kemper® Wire Clay Cutters

For slicing lumps of clay and cutting pots off the wheel, a wire clay cutter with 3" long hardwood toggle handles, firmly fastened to 18" of very strong, stainless steel twisted wire. The XL cutter is for larger, heavier clay items, with 3-1/4" long handles and a heavier gauge 24" long wire.

NUMBER	DESCRIPTION	EACH	12/EA
A30327-1018	Regular Cutter	\$2.65	\$2.39
A33099-1001	XL Cutter	4.30	3.87



Xiem™ Pro Cutting Wires

Useful for cutting large blocks of clay and for removing ware from the potter's wheel, these high-quality stainless steel cutting wires are coated in clear plastic for flexibility, strength, and resistance to kinking. The Perfect (11" long) is ideal for beginners and artists who throw small- to medium-size work. The Expert (19" long) is for more experienced artists who produce larger works. Each comes in a sturdy plastic case that prevents the wire from tangling when stored.

NUMBER	DESCRIPTION	SIZE	EACH	12/EA
A30498-1011	Perfect	11"	\$6.56	\$5.90
A30498-1019	Expert	19"	6.56	5.90



A Kemper Pottery Tool Kit

Quality tools made from the finest stainless steel and selected, smooth hardwood. Includes potter's rib, steel scraper, wood modeling tool, needle tool, ribbon tool, loop tool, sponge, and wire clay cutter.

NUMBER	EACH	12/EA
A30325-1009	\$19.09	\$17.18

B 8-Piece Beginner Pottery Tool Set

All the basic tools needed to get started in sculpting or for refining thrown or hand-built pottery. Eight-piece set includes a sponge, wire clay cutter, rib, and essential needle, ribbon, wire-end, and boxwood tools.

NUMBER	EACH	12/EA
A33091-1008	\$25.32	\$22.78

C Economy Tool Kit

An excellent starter set that includes all of the basic potter's tools — sponge, loop tool, wire clay cutters, pro needle, boxwood tool, potter's rib, ribbon tool, and metal scraper. Packaged in a segmented, reusable vinyl pouch.

NUMBER	EACH	12/EA
A30353-1089	\$15.19	\$13.67

D Deluxe 27-Piece Pottery Tool Set

An essential set of pottery and clay sculpting tools. This 27-piece deluxe set includes a wire clay cutter, two bristle brushes, a sumi brush, two broom corn brushes, a spoutmaker, ribs, and essential ribbon, wire-end, large paddle, and boxwood tools. The largest piece measures approximately 18" long.

NUMBER	EACH	12/EA
A34204-1009	\$87.35	\$78.61

Mudtools' Essentials Starter Kit

Responding to questions from beginning potters about the best tools for getting started, the "clay heads" at Mudtools responded with the Mudtools Essentials Starter Kit, a basic collection of nine indispensable tools that includes three polymer ribs, a Mudshark, a Mudwire, a long scraper rib, a small shredder, a Do•All trim tool, and a Mudspunge.



NUMBER	EACH
A31129-1001	\$96.59

Kemper Pot Lifts

These 5" pot lifts provide an easy method for removing pottery items from the throwing wheel without damage. Made from rust-free, high-strength aircraft aluminum alloy. Set of two.

NUMBER	EACH	4/EA
A30332-1005	\$12.65	\$11.38

500 ceramics 800.447.8192 to order

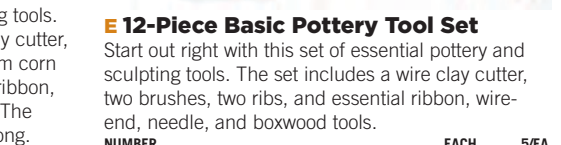

NUMBER	EACH	6/EA
A30318-0000	\$26.45	\$23.80

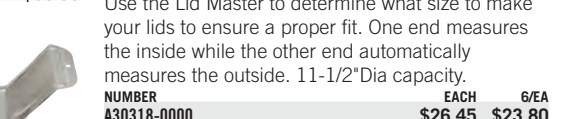

G Steel Calipers

Lightweight steel instruments for accurate inside or outside measuring.

NUMBER	SIZE	EACH	12/EA
A30326-1008	8"	\$8.27	\$7.43
A30326-1010	10"	9.41	8.46
A30326-1012	12"	11.27	10.13



Xiem™ Fluting Tool Set

This set provides a quick and easy way to create concave surface textures in both functional and non-functional ceramic pieces. Includes three titanium-bonded, rust-resistant, interchangeable blades (Small, Medium, and Large), and an ergonomic anti-roll handle. The blades are three times harder than steel, making them ideal for carving into leather-hard clay.

NUMBER	EACH	6/EA
A30994-1001	\$19.79	\$17.81



Amaco Clay Tile Cutter

Cutting soft clay slabs into tiles, rectangles, or strips is quick and easy with the Amaco Clay Tile Cutter. The 4" wide x 5/8" deep cutter allows artists to make 4" wide, 1/2" thick cuts in continuous rows. Made from durable plastic, the tool is safe for artists of all ages to use.

NUMBER	EACH	6/EA
A34379-1001	\$11.83	\$10.64



Kemper Throwing Sticks

These versatile tools are used to shape deep, wheel-thrown pieces with narrow interiors or necks, such as bottles or vases, when inserting the hand is not possible. Available in two head sizes, they're made from a highly polished hardwood for a comfortable feel in the hand. Both measure 12-1/2" long.

NUMBER	DESCRIPTION	EACH	12/EA
A30993-1001	Small	\$16.43	\$14.79
A30993-1002	Large	17.30	15.57



Spout Makers

A quick and easy way to make spouts or any other hollow element. Just wrap a clay slab around either tapered end of these solid maple tools. Once stiff, it can be added to a pot or sculpture. Regular Spout Maker, 8" x 3/4", is for spouts up to 6" long with openings as small as 3/4" Dia. Ultimate Spout Maker, 19" x 1 1/2", is for thin spouts up to 16" long, with openings as small as 1/4".

NUMBER	DESCRIPTION	EACH	12/EA
A30352-1010	Spout Maker	\$11.18	\$10.07
A30352-1020	Ultimate Spout Maker	18.55	16.70

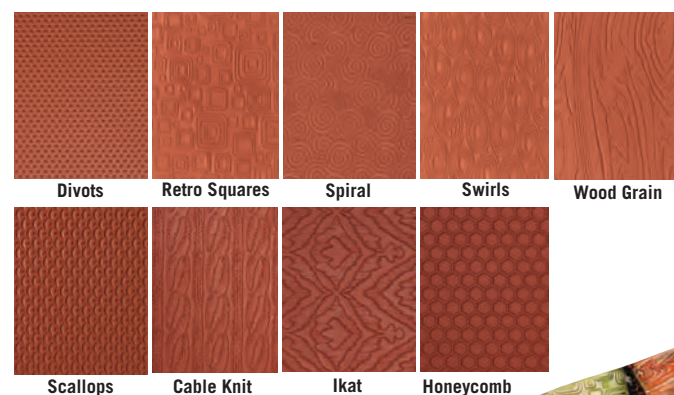

Mayco Designer Clay Mats

Mayco Designer Clay Mats are made of flexible latex rubber, the same material and thickness as Mayco Designer Stamps. These 7" x 9" mats are great for creating surface textures in clay or for applying glazes to create surface decoration.

NUMBER	DESCRIPTION	EACH	4/EA
A32702-1004	Divots	\$18.69	\$16.82
A32702-1002	Retro Squares	18.69	16.82
A32702-1005	Spiral	18.69	16.82
A32702-1003	Swirls	18.69	16.82
A32702-1001	Wood Grain	18.69	16.82
A32702-1006	Scallops	18.69	16.82
A32702-1007	Cable Knit	18.69	16.82
A32702-1008	Ikat	18.69	16.82
A32702-1009	Honeycomb	18.69	16.82



H-S Mayco Designer Stamps

Designer stamps give artists more choices when designing on ceramics: create patterns on glazes and acrylic paints, create outlines to be filled in, or stamp designs directly onto unglazed clay. Flexible 3" x 7" stamps are great on flat and curved surfaces, such as plates, cups, bowls, figurines, and more. For more designs, visit DickBlick.com. Designs can be assorted for quantity pricing.

NUMBER	DESCRIPTION	EACH	6/EA	NUMBER	DESCRIPTION	EACH	6/EA
A30396-1010	H Jambalaya	\$5.59	\$5.05	A30396-1070	N Cube Faces	\$5.59	\$5.05
A30396-1020	I Jumbo Swirl	5.59	5.05	A32981-1003	O Chinese Symbol	5.59	5.05
A30396-1030	J Fruit Blossoms	5.59	5.05	A30396-1110	P Circulate	5.59	5.05
A30396-1040	K Leafy Border	5.59	5.05	A30396-1120	Q Starry Swirls	5.59	5.05
A30396-1050	L Ornate Border	5.59	5.05	A30396-1180	R Dots/Squiggles	5.59	5.05
A30396-1060	M Asian Influence	5.59	5.05	A30396-1230	S Skyline	5.59	5.05



Class Pack of 6



Class Pack of 4

Amaco Clay Texture Roller Class Packs

Roll out a continuous design on a slab of clay with these textured clay rollers — great for tiles, vessels, or other works. Each roller sleeve offers a different design.

Class Pack of 6 — Includes six handles and six 4" wide roller sleeves (Diamond, Bamboo, Koi Fish, Vine/Leaf, Tribal, and Pre-Columbian).

NUMBER	DESCRIPTION	EACH	3/EA
A30704-6004	Class Pack of 6	\$66.99	\$60.29

Class Pack of 4 — Includes four handles and four 2-1/2" wide sleeves (Waves, Circles, Chain, and Pre-Columbian).

NUMBER	DESCRIPTION	EACH	3/EA
A30704-4025	Class Pack of 4	\$40.03	\$36.03



Amaco Pony Roller

Use this double-ended pony roller for flattening clay, smoothing surfaces, and creating textures with molds. The hardwood rollers are 4-1/2" and 2-3/4" wide and attached to a chrome-plated steel handle. The 2-3/4" roller is slightly tapered.

NUMBER	EACH	6/EA
A30702-1001	\$16.94	\$15.25



Amaco® Decorative Sprig Molds

Add variety, uniformity, and stability to teapots, mugs, cruets, pitchers, and other ceramic forms with handles and feet made using these plaster sprig molds. Each mold features a variety of designs. To transfer a design to your clay slab, place the slab on the mold, and either use a heavy clay roller or press firmly with your hands. Then remove the clay from the mold and shape it into the desired form. The absorbent plaster molds release quickly and cleanly.

NUMBER	DESCRIPTION	EACH	12/EA
A30705-1010	Foot Mold, 6 Designs	\$26.49	\$23.85
A30705-1020	Handle Mold, 4 Designs	42.39	38.15



Xiem™ Mini Art Rollers

Create quick and seamless patterns, textures, and fine details in clay with Xiem Mini Art Rollers. Each set includes an ergonomically designed handle with an angled stainless steel insert, plus three easily interchangeable rubber rollers with different modern designs. The handle allows the rollers to be rolled in any direction, including curves.

NUMBER	DESCRIPTION	EACH	12/EA
A32748-1029	Set B	\$15.90	\$14.29
A32748-1039	Set C	15.90	14.29
A32748-1049	Set D	15.90	14.29



Set B



Set C



Set D

Xiem™ Studio Attachable Letters and Numbers Stamps

Never worry about lining letters or numbers up again! These stamps are easy to snap together and combine for endless possibilities. Words, phrases, or numbers can be aligned horizontally or vertically. Great with ink, paint, clay, and underglazes.

NUMBER	DESCRIPTION	EACH	6/EA
A32752-1036	Lowercase Letters (36-pc Set)	\$21.99	\$19.79
A32752-1136	Uppercase Letters (36-pc Set)	21.99	19.79
A32752-1012	Numbers (12-pc Set)	9.87	8.89
A32752-1212	Extra Lowercase Letters (12-pc Set)	9.87	8.89
A32752-1112	Extra Uppercase Letters (12-pc Set)	9.87	8.89



Lowercase Letters (36-pc Set)



Style 1



Style 2

Mayco® Continuous Design Press Tools

Used to "stamp" engraved designs into your clay pieces, these plaster press tools are ideal for creating unique continuous designs. Each tool features two designs, each measuring 1" wide.

NUMBER	DESCRIPTION	EACH	4/EA
A30390-1020	Style 1	\$29.75	\$26.78
A30390-2020	Style 2	29.75	26.78



Mayco® Slump & Hump Molds

Get two molds for the price of one with these two-part plaster molds. Add embellishments to the inside of a shape or around the lip with a slump mold. Use a hump mold when adding feet, handles, or other embellishments to the outside of the shape. Note: plaster molds are not to be used for glass slumping.

Shapes can be assorted for quantity pricing.

NUMBER	DESCRIPTION	SIZE	EACH	4/EA
A30391-1030	Circle	5-3/4" Dia x 2-1/4" H	\$37.50	\$33.75
A30391-1050	Mask	8-1/4" L x 5-3/4" W	27.55	24.79
A30391-1020	Oval	7" L x 5-1/2" W x 1-3/4" H	37.50	33.75
A30391-1010	Rectangle	7-1/2" L x 4" W x 1" H	37.50	33.75
A30391-1040	Square	5-3/4" L x 1" H	37.50	33.75



Amaco® Drape Molds

Available in seven shapes and sizes, these smooth-cast plaster drape molds allow you to form bowls or halves of hollow shapes evenly. Just lay the clay slab over the mold and allow it to dry. Note: Plaster molds are not to be used for glass slumping. Shapes can be assorted for quantity pricing.

NUMBER	DESCRIPTION	SIZE	EACH	6/EA
A32962-1013	Dinner Plate	13" Diameter	\$61.49	\$55.30
A32962-1009	Round	9" Diameter	70.99	63.89
A32962-1008	Square	8"	78.89	70.99
A32945-1001	Rectangle	7-1/4" x 5-5/16" x 1-5/8"	35.85	32.29
A32945-1002	Rectangle	9-3/8" x 4-1/2" x 1-1/2"	35.85	32.29
A32945-1003	Rectangle	10-3/4" x 7-1/2" x 7/8"	35.85	32.29
A32945-1005	Egg Shaped	7-3/16" x 5-1/2" x 2-3/4"	35.85	32.29
A32945-1006	Egg Shaped	10-1/2" x 7" x 1-3/4"	35.85	32.29
A32945-1007	Long Oval	11-3/4" x 5-1/16" x 2"	35.85	32.29



Small Designs



Designs



Spiral Designs



Native American Designs



Leaf Designs

Mayco® Press Tool Sets

Use these press tools to stamp incised designs into rolled-out clay. The smaller designs are also great for stamping clay beads for jewelry making.

NUMBER	SET	DIAMETER	EACH	4/EA
A30390-1006	6 Small Designs	3/4"	\$18.75	\$16.89
A30390-1036	6 Designs	3/4"	29.75	26.78
A30390-1004	4 Spiral Designs	1-1/2"	29.75	26.78
A30390-1040	4 Native American Designs	1-3/4"	29.75	26.78
A30390-2040	4 Leaf Designs	1-3/4"	29.75	26.78



A-F Mayco® Designer Silkscreens

These intricate, highly illustrative designs printed on a fine mesh screen are great for silkscreening onto greenware or bisque. Each 12" x 15" silkscreen contains images within a common theme such as woodland animals, botanicals, or symbols. The screens are reusable and easy to clean. To use, simply cut out the desired design, place it over the item to be silkscreened, and apply glaze that has been thickened with Silkscreen Medium for crisp, detailed designs.

NUMBER	DESCRIPTION	EACH	12/EA
A32704-1006	A Bugs	\$22.05	\$19.85
A32704-1005	B Flowers	22.05	19.85
A32704-1004	C Leaves	22.05	19.85
A32704-1010	D Nautical	22.05	19.85
A32704-1002	E Sea Life	22.05	19.85
A32704-1012	E Small Birds	22.05	19.85
A32704-1007	F Stylized	22.05	19.85
A32704-1003	Trees and Grass	22.05	19.85
A32704-1001	Woodland Animals	22.05	19.85
A32704-1013	F Zoo Animals	22.05	19.85



AC-310 Silkscreen Medium

Silkscreen Medium — This thickening agent creates a "ceramic paste" when added to glazes, underglazes, or acrylic paints in preparation for silkscreening. Use it with Mayco Designer Silkscreens or on greenware, bisque, glass, or fabric. 4 oz jar.

NUMBER	EACH	12/EA
A32704-1011	\$2.95	\$26.65



Mayco® Clay Canvas

A great surface for creating complex (or very simple) wall hangings, Mayco Clay Canvas is made entirely of earthenware that has been bisque-fired to accept acrylic paints or ceramic glazes. Glazed pieces should be fired to cone 06/05. The back of the clay canvas features a recessed lip, which makes hanging portraits, landscapes, or abstract masterpieces quick and easy.

NUMBER	SIZE	EACH	6/EA
A32982-1003	6" x 6"	\$8.63	\$7.75
A32982-1012	8" x 10"	10.59	9.53

Ceramic Bisque Tiles

These fine-quality, low-fired white clay tiles are ready to decorate with your choice of glaze to make trivets, borders, tabletops, coasters and more. Fire between Cone 01 and Cone 03.

NUMBER	SIZE	EACH	12/EA
A32916-1043	4-1/4" x 4-1/4"	\$.74	\$.67
A32916-1001	6" x 6"	1.75	1.59

Box of 12 — Fire at a maximum of Cone 06.

NUMBER	SIZE	EACH	12/EA
A32950-1004	4-1/4" x 4-1/4"	\$15.28	\$13.74
A32950-1006	6" x 6"	24.24	21.80



Earthenware Bisque

Hand-personalized ceramics are fun for schools, community centers, and more! Earthenware bisque with machine-pressed, smooth bodies for beautiful brushstrokes every time. Low fire cone 04; compatible with 05-06 glazes and underglazes (food-safe when cone 06 glaze-fired). Can also decorate with acrylic paints (non-food use only).

Tableware Plates — Create place settings with salad, dinner, and charger plates. All feature classic rim design with plenty of room for decoration.

NUMBER	DESCRIPTION	EACH	3/EA
A32947-1010	Rim Salad Plate, 6	\$28.75	\$25.87
A32947-1020	Rim Dinner Plate, 6	33.30	29.97
A32947-1030	Rim Charger Plate, 6	46.34	41.71
A32947-1070	Coupe Salad Plate, 12	62.28	56.04
A32947-1080	Coupe Dinner Plate, 12	72.06	64.86
A32980-8060	Rice Bowl, 12	63.49	57.15

Mayco® Bisquette Medallions

25 each of six 1" x 1" shapes. Can be fired to cone 05 or 06. Includes heart, round, square, rectangle, oval, and triangle. 150 assorted pieces total.

NUMBER	EACH	6/EA
A32946-1509	\$93.05	\$83.75



G-R Duncan® Oh Four® Bisque

Duncan Oh Four Bisque is formulated with pure earthenware clay and made using a very consistent manufacturing process, for a more stable end result. To use, clean the bisque piece with a damp sponge to remove any dust, then decorate it with glazes or underglazes and allow it to dry. Fire to Cone 06. Glazes applied to these pieces are guaranteed not to shiver, regardless of the brand of glaze being used. Pair with the complete line of Duncan glazes and underglazes for exceptional, consistent results.

NUMBER	DESCRIPTION	EACH	6/EA
A32722-1001	G Small Geometric Bowl	\$6.28	\$5.65
A32722-1002	Medium Geometric Bowl	9.42	8.48
A32722-1003	H Chef Mug	4.93	4.44
A32722-1004	I Donut Mug	5.38	4.84
A32722-1005	J Planter with Base	7.63	6.86
A32722-1006	K Teapot	11.22	10.10
A32722-1008	L Cactus Plate	9.87	8.88
A32722-1010	M Coupe Dinner Plate	4.75	4.28
A32722-1011	N Coupe Dessert Plate	2.78	2.50
A32722-1012	O Cereal Bowl	4.66	4.20
A32722-1013	P Coupe Oval Platter	10.86	9.77
A32722-1014	Q Short 20 oz Mug	5.56	4.99
A32722-1015	R Tea Cup and Saucer	5.20	4.68



Mugs — Large, comfortable handles.

NUMBER	DESCRIPTION	EACH	3/EA
A32947-1040	Regular Mug, 4	\$18.22	\$16.37
A32968-1001	Travel Mug w/Lid, 1	8.40	7.55

Switchplates — Single or double outlet switchplates include inset screw holes and beveled edges. Fit all standard U.S. switch boxes.

NUMBER	DESCRIPTION	EACH	3/EA
A32947-1050	Single, 12	\$62.30	\$56.06
A32947-1060	Double Switchplate, 12	76.38	68.73



high-fire clays



Amaco® No. 38 White Stoneware Clay

Cone 5–10 (2205°–2381°F)

This moist, de-aired stoneware clay is formulated from choice clays for plasticity and whiteness, plus fire-clay to give it more body. It contains no grog, yet has the strength for throwing large pieces. Firing range is from Cone 5 to 10 (2205°–2381°F). At Cone 5, shrinkage is 13% and absorption is 7%. At Cone 10, shrinkage is 15%, absorption is 1.4%, and the clay fires white in oxidation and gray in reduction, both delicately peppered with darker gray spots. 50 lb carton. Does not qualify for free shipping offer. See shipping exceptions on page 648.

NUMBER	EACH	5/EA
A30503-1038	\$31.69	\$28.50



Blick® Stoneware Clay

Cone 5–10 (2205°–2381°F)

Blick's moist stoneware clay is a ready-to-use, de-aired, homogenous mixture that needs little or no wedging. Its smooth, plastic consistency makes it excellent for throwing as well as modeling, coiling, and slab building. At Cone 5 (2205°F) shrinkage is 12% and absorption is 1.8%. At Cone 10 (2381°F), the dense, vitreous ware is a soft gray with a shrinkage of 13.2% and absorption of 0%. 50 lb carton consists of 2, 25 lb bricks, each in a poly storage bag. Does not qualify for free shipping offer. See shipping exceptions on page 648. AP non-toxic when moist. In dry form, product carries a health warning.

NUMBER	EACH	5/EA
A30517-1050	\$30.05	\$27.05



Amaco No. 480 Speckled Buff Stoneware Clay

Cone 5–10 (2205°–2381°F)

The absence of grog gives this clay a smooth surface with superior plasticity. Excellent for throwing, hand-modeling, and casting, Amaco No. 480 is a warm buff color peppered with dark specks when fired to Cone 5–6. At lower temperatures, it is somewhat lighter and less vitreous. Transparent and light matte glazes allow the dark specks to show, creating a peppered effect. Partial glazing and slip trailing also create interesting results. At Cone 5, shrinkage is 10.6% and absorption is 5.2%. At Cone 10, shrinkage is 10.8% and absorption is 1.9%. 50 lb carton contains two 25 lb bags.

NUMBER	EACH	5/EA
A33625-1050	\$45.79	\$41.25



Amaco® No. 58 Warm Brown Stoneware Clay

Cone 5–7 (2205°–2295°F)

Supremely versatile, No. 58 is a great all-around classroom clay. Made from several clays chosen for their plasticity and color qualities, No. 58 has the warm brown color when fired in oxidation up to Cone 7, terra cotta color when fired at Cone 05. At Cone 5, shrinkage is 14.2% and absorption is 3%. At Cone 7, shrinkage is 14.4% and absorption is 0.4%. 50 lb carton. Does not qualify for free shipping offer. See shipping exceptions on page 648. AP non-toxic when moist. In dry form, product carries a health warning.

NUMBER	EACH	5/EA
A30527-1050	\$33.25	\$29.99

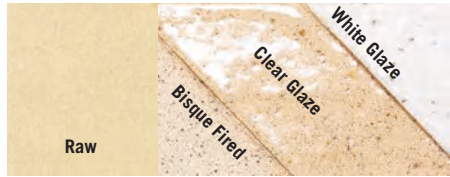

Amaco® No. 48 Stoneware Clay with Grog

Cone 5–10 (2205°–2381°F)

Ideal for larger work, No. 48 is made from several clays chosen for their plastic qualities, plus coarse fireclay and grog. Offering superb texture for throwing, hand-building, and sculpting, it fires to a warm speckled buff color at Cone 5-6 oxidation, and is dark brown after reduction firing. At Cone 5, shrinkage is 11.3% and absorption is 6%. At Cone 10, shrinkage is 11.7% and absorption is 2.9%. 50 lb carton. Does not qualify for free shipping offer. See shipping exceptions on page 648.

NUMBER	EACH	5/EA
A30528-1050	\$42.89	\$38.60



Standard Ceramic 213 Porcelain Clay

Cone 6 (2232°F)

Standard Ceramic 213 Porcelain Clay is a white clay body formulated for firing at Cone 6. Plastic and throwable, it has a shrinkage rate of 12% and an absorption rate of 2%. Made in the USA. 50 lb carton.

NUMBER	EACH	5/EA
A30593-1001	\$33.56	\$30.20

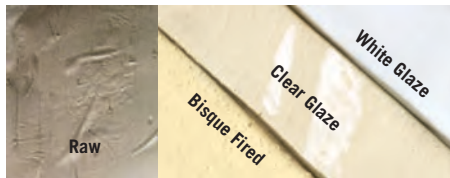

Standard Ceramic 553 Warm Buff Stoneware Clay

Cone 5–6 (2167–2232°F)

Ideal for larger wheel or sculptural work, this is an excellent all-purpose clay that fires to a cream color at Cone 5. It is a very plastic clay body that is blended with coarse sand and medium grog. Bisque to Cone 04–03. Two 25 lb bags.

NUMBER	EACH	5/EA
A30546-1170	\$38.27	\$34.51

low-fire clays



Sio-2 PRAI White Stoneware Clay

Cone 6–10 (2269°–2381°F)

This white stoneware clay body features 40% grog that is so fine, it's unable to be felt. Formulated for artistic ceramics, PRAI is ideal for wheel-throwing and modeling smooth pieces with fine details. It fires to an ivory color and is excellent ware for glazes and coloring oxides, which develop bright and intense tones. Sio-2 PRAI is available in moist form in a 27.6 lb package.

NUMBER	SIZE	EACH	5/EA
A30585-1022	27.6 lb	\$22.95	\$20.65



Standard Ceramic 239 Raku Clay

Cone 04 (1971°F)

An open clay body specially formulated to withstand the thermal shock of raku firing, Standard Ceramic 239 Raku Clay contains sand. Bisque fire to Cone 04. Recommended firing is Cone 04. Shrinkage is 8% at Cone 04, and absorption is 17% at Cone 04. De-aired and ready to use. The 50 lb carton contains two 25 lb bags. Does not qualify for free shipping offer. See shipping exceptions on page 648.

NUMBER	EACH	5/EA
A30548-1250	\$26.40	\$23.76



Standard Ceramic 547 Red Sculpture Clay

Cone 2–6 (2127°–2269°F)

Great for larger wheel and sculptural forms, this red earthenware clay has a very organic, raw quality. Medium grog and 35-mesh sand give it a coarse texture that provides strength to the fired product while reducing shrinkage. Color ranges from reddish-orange when fired to earthenware temperatures, and deepens to a brick red if the temperature is increased. Bisque fire to Cone 04. The recommended firing is Cone 6. De-aired and ready to use. 50 lb carton contains two 25 lb bags. Does not qualify for free shipping offer. See shipping exceptions on page 648.

NUMBER	EACH	5/EA
A30540-3760	\$32.39	\$29.15

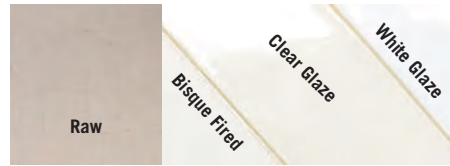

Blick® White Talc-Free Clay

Cone 05–3 (1911°–2138°F)

This low-fire, de-aired, talc-free moist clay is gray-white in its raw state and white when fired. Suitable for hand-building, modeling, and throwing, it's unusually craze-resistant, with a plasticity that makes even large pieces easier to throw. Recommended for Cone 05, this clay can be fired as high as Cone 3 without distortion. A 50 lb carton contains two 25 lb bags. Does not qualify for free shipping offer. See shipping exceptions on page 648. AP non-toxic when moist. In dry form, product carries a health warning.

NUMBER	EACH	10/EA
A30544-1050	\$30.90	\$27.81



Amaco® No. 27 White Sculpture Raku Clay

Cone 05–5 (1911°–2205°F)

Finely ground white clays are combined with medium mesh buff grog, increasing porosity and reducing cracking, shrinking, and warping. This de-aired, moist clay is recommended for raku, but can also be used to hand build and throw larger pieces without fear of slumping or cracking. Wide firing range from Cone 05 to 5. At Cone 04 the bisque is white with some black specks and the shrinkage is 7% with a 16% absorption. At Cone 5 (2205°F), the ware is light buff with very few specks and the shrinkage is 9% and 10% absorption. When used for raku, most unglazed areas will turn dark gray to black. 50 lb carton. Does not qualify for free shipping offer. See shipping exceptions on page 648.

NUMBER	EACH	5/EA
A30509-1027	\$39.80	\$35.80

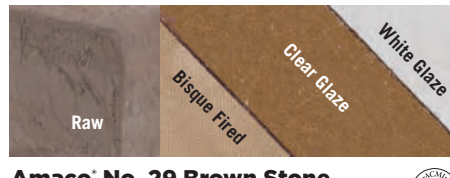

Amaco® No. 29 Brown Stone Earthenware Clay

Cone 05–5 (1911°–2205°F)

No. 29 is formulated from several clays for plasticity and texture. This light brown talc-free earthenware clay contains tiny specks that give it the look of gas-fired and reduced stoneware. It contains a fine grit that makes it stronger and easier to throw larger pieces. No. 29 is excellent for all types of hand-building, slab work, extrusions, sculpture, and wheel-throwing. Any Amaco low-fire glaze works well on this body. Because of its wide firing range, Amaco high fire glazes also achieve good results. 50 lb carton contains two 25 lb blocks of clay.

NUMBER	EACH	6/EA
A30532-1050	\$33.60	\$30.25

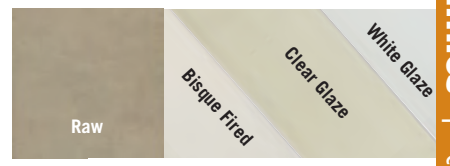

Standard Ceramic 105 White Clay

Cone 06–04 (1855°–1971°F)

This very smooth, white clay body is excellent for both hand-building and wheel-throwing. It works well with most commercial low-fire glazes. Bisque fire to Cone 04. A firing range of Cone 06–04 is recommended. Shrinkage is 6% at Cone 06, and 6.5% at Cone 04. Absorption is 16% at Cone 06, and 15.5% at Cone 04. 50 lb carton contains two 25 lb bags. De-aired and ready to use.

NUMBER	EACH	5/EA
A30548-1050	\$36.28	\$32.65



Amaco® No. 25 White Art Clay

Cone 05–3 (1911°–2138°F)

An all-purpose, low-fire, de-aired, moist clay that is gray-white in the raw state and more intensely white when fired. It has an unusual resistance to crazing. Suitable for all hand-building methods, modeling, and wheel-throwing. Extremely plastic formula. Practical for the classroom and all areas of ceramics. Recommended to be glazed fired to Cone 05, but pieces can be fired as high as Cone 3 (2138°F) without distortion. At Cone 04, shrinkage is 6.3% and absorption is 13.7%. 50 lb carton contains 2, 25 lb bags. Does not qualify for free shipping offer. See shipping exceptions on page 648. AP non-toxic when moist. In dry form, product carries a health warning.

NUMBER	EACH	5/EA
A30505-1025	\$30.49	\$27.45



Standard Ceramic 105 White Clay with Grog

Cone 06–04 (1855°–1971°F)

This smooth, white-firing, de-aired earthenware clay is excellent for both hand-building and wheel-throwing, and for larger wheel and sculptural forms. It works well with most commercial low-fire glazes. Choice plastic clays with added coarse sand give this clay body strength and texture while reducing cracking. Dark gray in its moist state, and ivory white after firing, Standard Ceramic 105 White Clay With Grog should be bisque fired to Cone 04. De-aired and ready to use. The recommended firing range is Cone 06–04. Shrinkage is 5% at Cone 06, and 5.6% at Cone 04. Absorption is 16% at Cone 06, and 15.5% at Cone 04. The 50 lb carton contains two 25 lb bags. Does not qualify for free shipping offer. See shipping exceptions on page 648.

NUMBER	EACH	5/EA
A30540-1040	\$24.80	\$22.32

HEALTH & SAFETY ICONS: ●=CL / ■=Prop 65 / ▼=CL & Prop 65
See page 644 for more information.

WARNING! Products marked with a Prop 65 symbol (■ or ▼) can expose you to chemicals, including cadmium, which are known to the State of California to cause cancer and birth defects or other reproductive harm. For more information, visit P65Warnings.ca.gov.



Blick® Red Earthenware Clay

Cone 05–02 (1911°–2052°F)
This is an excellent talc-free clay with a wide firing range. At Cone 05, shrinkage is 11.7% and absorption is 7%; at Cone 02, shrinkage is 13% and absorption is 9.2%. Excellent for wheel-throwing or hand-building techniques, it retains its red color after firing. AP non-toxic when moist. In dry form, product carries a health warning. 50 lb carton contains two 25 lb bags of moist clay.

NUMBER	EACH	5/EA
A30543-3550	\$30.05	\$27.05



Amaco® No. 77 Terra Cotta Stoneware Clay

Cone 05–5 (1911°–2205°F)
Terra Cotta is a mixture of finely ground red and buff clays, plus a medium mesh grog. Grog makes fired pottery more porous and reduces cracking, shrinkage, and warping. Recommended for wheel-thrown pots and hand-built sculpture, tiles, planters, and outdoor pottery. At Cone 04 the clay is terra cotta in color with a shrinkage of 6.75% and an absorption of 9%. At Cone 5 the color is a rich brown-red with a shrinkage of 10.5% and an absorption of 0.9%. 50 lb carton contains two 25 lb bags of moist clay. Does not qualify for free shipping offer. See shipping exceptions on page 648.

NUMBER	EACH	5/EA
A30507-8123	\$42.35	\$38.12



Active® Blackjack Clay

Cone 6–10 (2269°–2381°F)
A combination of several different clays, Blackjack Clay is perfect for hand-building, and it won't sag, making it ideal when vertical side strength is needed. It bonds easily to itself and adapts to coil-building, free-form sculpture, and throwing. It can be carved and decorated easily when leather-hard, and may be glazed as greenware or added to bisque ware before a second firing. Seal to keep moist. Milk chocolate color; becomes soft buff/tan when fired.

NUMBER	SIZE	EACH	6/EA
A33297-1305	5 lb	\$14.41	\$12.96
A33297-1325	25 lb	31.66	28.49

Low Fire Clay — Ideal for craft projects such as hand-building, wheel-throwing, sculpture, and modeling, this non-toxic modeling clay is excellent for children's arts and crafts projects, and for artists at all skill levels, from beginners to professionals. Cone 06-04.

NUMBER	SIZE	EACH	6/EA
A33674-1005	5 lb	\$15.72	\$14.14
A33674-1025	25 lb	42.05	37.85
A33674-1050	50 lb	67.69	60.89



Amaco® No. 67 Sedona Red Clay

Cone 05–02 (1911°–2052°F)
A rich, red color before and after firing. Excellent for all hand methods of modeling, slab, coil, sculpture, and wheel-throwing. Wide firing range of Cone 05-02 (1911°–2052°F). At Cone 05, shrinkage is 11.7% and absorption is 7%. At Cone 02, shrinkage is 13% and absorption is 9.2%. Fires well without slumping. 50 lb carton contains two 25 lb bags of moist clay. Does not qualify for free shipping offer. See shipping exceptions on page 648.

NUMBER	EACH	5/EA
A30506-3050	\$32.70	\$29.45

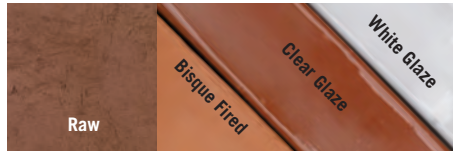

Standard Ceramic 104 Red Clay with Grog

Cone 06–4 (1855°–2161°F)
This formula is blended with fine grog, which makes it an excellent choice for both hand-building and wheel-throwing. It has a reddish-orange clay body when fired to earthenware temperatures (Cone 04). The color deepens to a brick red color if the firing temperature is increased to Cone 3. Pieces made with this clay should be slow bisque-fired to Cone 04. A firing range of Cone 06–4 is recommended. Shrinkage is 6% at Cone 06, and 11% at Cone 4. Absorption is 13.2% at Cone 06, and 3% at Cone 4. 50 lb carton contains two 25 lb bags. De-aired and ready to use. Does not qualify for free shipping offer. See shipping exceptions on page 648.

NUMBER	EACH	5/EA
A30548-8150	\$40.67	\$36.60



Amaco® No. 5 Decorating Wheel

A popular studio decorating wheel, the all-aluminum Amaco No. 5 is perfect for modeling, finishing, or decorating. The all-aluminum 7" Dia head with concentric circles rotates on a ball bearing and is weighted at the rim for greater momentum. The wheel has drilled extensions for attaching to a table, and the wheel shank is grooved to accommodate a small belt for mechanization.

NUMBER	EACH
A30211-1005	\$47.50



Artwork by Deb Fritts
"In a Row"



Amaco® Bisque Fix

This white paste is an excellent mending material for bisque. Use it to bond bisque pieces together or fill up broken cavities. Can be colored to match the bisque using metal oxides or ceramic stains. After applying with a spatula, fire to the temperature of the clay and glaze that you are using. 4 oz jar.

NUMBER	EACH	5/EA
A32966-1004 ▼	\$25.85	\$23.25



Amaco® Decorating Wheel

Conveniently compact and stackable for classroom use, this lightweight wheel makes banding, modeling, sculpting, and decorating accurate and easy. 8" plastic wheel head.

NUMBER	EACH
A30211-1700	\$26.99



Shimpo® Banding Wheels

Ideal for decorating, sculpting, carving, and hand-building, Shimpo banding wheels are designed to provide extra-smooth, even rotation for even the most delicate of applications. Their one-piece design features solid, cast-iron construction, a rust-resistant blue paint coating, and sealed ball bearings for smooth rotation without wobbling or sticking. One-year manufacturer's warranty.

NUMBER	DIAMETER	HEIGHT	EACH
A30260-4808	8-3/4"	2-1/2"	\$80.45
A30260-4809	9-7/8"	7-1/2"	121.25
A30260-4811	11-3/4"	4-3/4"	143.30
A30260-1007	7"	2-3/4"	66.15

HEALTH & SAFETY ICONS: ●=CL / ■=Prop 65 / ▼=CL & Prop 65
See page 644 for more information.

understanding pottery wheels

Ceramicists usually know what they like about a particular pottery wheel, but they may not know everything they should know when buying their first wheel or replacing an existing one. We asked some of the most recognized and respected names in the industry to help us take the mystery out of buying a pottery wheel. Here's what the experts had to say.

Q. How important is motor size? And how does it relate to throwing capacity?

A. This may be the most important decision of all, and it can be confusing. Generally speaking, the higher the horsepower (HP), the larger the amount of power — or torque — your wheel will have. The most important thing is to choose the size that meets your needs, with power to spare as your skill level increases or as you begin throwing larger or more complex pieces.

The difference between "peak-duty" and "continuous-duty" horsepower ratings is also an important distinction. Continuous-duty motors are designed to run fully loaded 24 hours a day without overheating, while peak-duty motors will provide power for a shorter period of time. Look for this information on the motor's nameplate.

A wheel's throwing capacity can range from 25 lbs up to 300 lbs and even more. Keep in mind — the average mug weighs approximately 1 lb, so be realistic about the amount of power you need. Throwing capacity is a subjective measure that may vary based on the experience and ability of the artist — keep this in mind when choosing motor size.

A good rule of thumb is that a 1/3 HP motor is adequate for most hobbyists and beginning and intermediate students throwing vessels smaller than 50 lbs, while 1/2-1 HP motors are best suited for advanced students and professional potters who may be throwing larger pieces.

Q. Direct drive or belt-driven — which is better?

A. Many pottery wheels feature a belt-driven motor that has a mechanically controlled commutator (or rotor) system based on brushes. The latest innovation in pottery wheel motors is the DC (direct-current) direct-drive motor, which is brushless, beltless, electronically controlled, and extremely quiet. When the motor is turned off, the wheel head will spin freely, much like a banding or decorating wheel.

Wheels with belt-driven motors have served the pottery community dependably for many years, and recent innovations have eliminated some of the noise they produce. Direct-drive motors lack the torque of belt-driven motors and are much more expensive to repair; however they have been proven to require less maintenance, thus extending the useful life of the wheel.

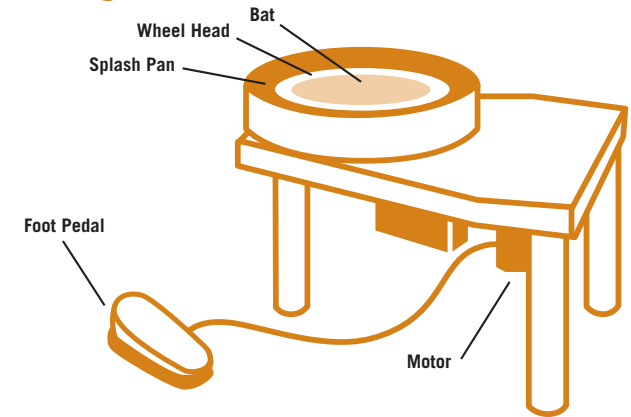

Pottery Wheel Key

Splash Pan	Keeps water and trimmings contained. One-piece or two-piece.
Wheel Head	The rotating disc on which clay is thrown and shaped.
Bat	A removable disc for removing and transporting finished pieces.
Foot Pedal	Controls the speed of the wheel head while throwing.
Motor	Powers the wheel. Horsepower (HP) varies by model.

The decision to purchase a belt-driven or direct-drive wheel is a personal one that depends upon your budget, how much and how long you intend to use your wheel, and how important the quietness factor is to you.

Q. What size wheel head?

A. The wheel head is the rotating disc on which clay is thrown, shaped, and sometimes decorated. Made of metal and marked with concentric circles, the size of the wheel head you choose (typically 12" or 14" in diameter) depends on how large the pieces are that you'll be throwing. Most wheel heads are drilled with at least two bat pin holes for attaching a bat — the removable disc that allows you to remove completed pieces without damaging or deforming them.

Q. What's a reversing switch and how important is it?

A. A reversing switch allows easy switching from one direction to the other, as well as providing a neutral position for smooth transitions when changing directions. In teaching environments, a reversing switch allows for both left-handed and right-handed potters to use the same wheel interchangeably. While in the neutral position, the wheel head will spin freely in both directions, to allow banding or decorating. A reversing switch is generally an optional feature, depending on the manufacturer.

For more information,
visit DickBlick.com.

Q. What about portability?

A. How portable your wheel needs to be depends upon the size of your room or studio and how much space you can dedicate to it. Some pottery wheels are more or less stationary because of their weight or configuration, while some have removable legs or "booties" that allow them to be used on a tabletop or floor and stored out of the way when not in use. Some wheels incorporate work surfaces, seats, and splash pans into their design, which adds to their overall size.

For potters who ascribe to the "simpler is better" school, a small tabletop wheel might be best. For those who want their tools, clay, and water containers close at hand, a larger wheel with an attached work surface for these items might be the best choice.

The goal is to find the wheel that is most comfortable for you while throwing, in a configuration that suits your working style and your space.

Q. How important is the manufacturer's warranty?

A. Warranties vary widely from manufacturer to manufacturer. As with any important purchase, be sure to fill out and return the warranty form immediately to make sure you're protected against defects in materials and workmanship. There may be other stipulations, so read the fine print, keep your purchase receipt in a safe place, and make sure all warranty work is performed appropriately (i.e., by the manufacturer or an authorized dealer recommended by the manufacturer). Also ask if the wheel can be repaired locally, or if you'll be required to ship it elsewhere for repair.

WARNING! Products marked with a Prop 65 symbol (■ or ▼) can expose you to chemicals, including cadmium, which are known to the State of California to cause cancer and birth defects or other reproductive harm. For more information, visit P65Warnings.ca.gov.



for artists and schools

A Skutt® Thomas Stuart Prodigy Potter's Wheel

- 1/3 HP continuous-duty motor
 - 12" wheel head
 - 75 lb centering capacity
 - 1-piece removable splash pan
 - SCR controller
 - 5-year warranty
- Truck Shipment and FOB Factory.
See page 648 for details.

NUMBER A30038-1000 EACH \$1422.00

B Shippo® VL-Whisper Pottery Wheel

- 1/2 HP DC Motor
 - 14" alloy wheel head
 - 100 lb centering capacity
 - Adjustable, removable legs offer different heights for floor and tabletop use
 - 2-part splash pan
 - 5-year warranty
- Truck Shipment and FOB Factory.
See page 648 for details.

NUMBER A30040-1001 EACH \$1438.00

C Shippo® VL-Lite Pottery Wheel

- 1/2 HP reversible DC motor
 - 12" wheel head
 - 2-piece removable splash pan
 - 25 lb centering capacity
 - 2-year warranty
- Truck Shipment and FOB Factory.
See page 648 for details.

NUMBER A30041-1001 EACH \$955.00

D Speedball® Clay Boss Potter's Wheel

- 1/2 HP
 - 14" wheel head
 - 100 lb centering capacity
 - Adjustable height glide feet
 - 2-part splash pan
 - 10-year warranty
- FOB Factory.
See page 648 for details.

NUMBER A30017-1002 EACH \$1259.00

E Skutt® Thomas Stuart Legend Potter's Wheel

- 1/3 HP continuous-duty motor
 - 14" wheel head
 - 400 lb centering capacity
 - Oversized legs for stable support
 - 1-piece removable splash pan
 - 5-year warranty
- Truck Shipment and FOB Factory.
See page 648 for details.

NUMBER A30038-1013 EACH \$1953.00

F Laguna® Pacifica Glyde Torc 400

- 1/2 HP
 - 13" wheel head
 - 80 lb centering capacity
 - High torque even at low speeds
 - 2-year warranty
- Truck Shipment and FOB Factory.
See page 648 for details.

NUMBER A30002-0000 EACH \$1087.00

Seat — Padded, formed steel seat with a comfy back. Mounts easily onto the single front leg. FOB Factory. See page 648 for details.

NUMBER A30002-0100 EACH \$162.70

G Speedball® Artista™ Potter's Wheel

- Tabletop wheel
- 1/3 HP
- 11" wheel head
- Portable and economical
- 25 lb centering capacity
- 2-part splash pan
- Right- or left-handed models
- 2-year warranty FOB Factory. See page 648 for details.

NUMBER	DESCRIPTION	EACH
AF30029-1010	Right-handed	\$667.00
AF30029-1020	Left-handed	616.00

H Shippo® Aspire Pottery Wheels

- Tabletop wheel
- 1/3 HP
- 20 lb centering capacity
- 7" alloy wheel head
- 1-piece removable splash pan
- Choose hand lever or foot pedal control
- 5-year warranty FOB Factory. See page 648 for details.

NUMBER	DESCRIPTION	EACH
AF30042-1002	With Foot Pedal	\$640.00
AF30042-1001	With Hand Lever	565.00



brent®

Cast iron wheel hub assembly.
Dynamically balanced for motion stability.

Wheel head bearings are sealed for water resistance.

6-groove poly-v-belt drive with automatic tensioning.
Seamless belt stays tight for maximum performance and smooth operation.

Permanent magnet DC motor for high torque at all speeds.
Custom manufactured to Brent® specifications.

Controller has modular design connections to make upgrades and replacements easy.

Machined cast aluminum wheel head.
Engineered with tapered, reinforced ribs for stability. Bat pins are precision-drilled for accuracy.

Removable splash pan for quick and easy cleaning.

All-welded construction, solid steel table with durable poly cover.
Steel legs are powder-coated for corrosion and scratch-resistance.

Classic Controller keeps wheel speed constant under varying loads.
Electronic noise filtering for quiet operation.

EZ-feel toggle switches are sealed for protection.
Forward/reverse has neutral safety position for smooth transitions and use as banding wheel.

Durable cast aluminum foot pedal with 4 ft cord.
Delivers smooth control and speed range of 0-240 rpm.

FREE Plasti-Bat® and Instructional DVD with every Brent® wheel!



for artists and schools



Handles
150 lbs Clay
Continuously

Model B

- 1/2 HP, 5A motor
- 14" wheel head
- 10-year warranty
- \$100 AMACO glaze rebate

NUMBER AF30007-0000 EACH \$1878.00



Handles
225 lbs Clay
Continuously

Model C

- 3/4 HP, 7A motor
- 14" wheel head
- 10-year warranty
- \$100 AMACO® glaze rebate

NUMBER AF30006-0000 EACH \$1900.00



Handles
300 lbs Clay
Continuously

Model CXC

- 1 HP, 10A motor
- 14" wheel head
- 10-year warranty
- \$100 AMACO glaze rebate

NUMBER AF30020-0000 EACH \$1965.00



Handles
450 lbs Clay
Continuously

Model EX

- 1-1/2 HP, 15A motor
- 14" wheel head
- 10-year warranty
- \$100 AMACO glaze rebate

NUMBER AF30024-0000 EACH \$2135.00



Model 16

- 1/2 HP, 5A motor
- 14" wheel head
- 10-year warranty
- \$100 AMACO glaze rebate
- Adjustable wheel head height
- Can accommodate a wheel chair
- Mobile with hard rubber casters
- Fits through any 36" door
- Stationary during throwing; four rubber feet raise the casters off the floor

NUMBER AF30021-1016 EACH \$3995.00

Optional Seat

- Attaches to Model B, C, CXC, and EX wheels manufactured after January 2009
- Adjustable for height and distance from the wheel head

NUMBER A30005-0000 EACH \$335.75

For Work Tables, Work Stations, Seats, Splash Pans, and Bats, Visit DickBlick.com.



Splash Pans

- For use with all Brent pottery wheels
- Easily snap under the top bearing housing to catch excess water
- Remove easily for cleaning
- Measure 17-1/2" in diameter x 4-1/2" high

NUMBER	COLOR	EACH
A30005-2050	Black	\$61.50
A30005-0100	Gold	61.50

Helpful for individuals with special needs.



A Amaco® Plasti-Bats

Plasti-Bats are drilled with bat pin holes to fit on Amaco or brent pottery wheels. Made of rigid, 1/4" to 1/3" thick, high-impact plastic that will not splinter, swell, or shrink, these versatile, long-lasting, reusable bats are virtually indestructible. Impervious to water and most chemicals, they're easy to clean and can be reused.

NUMBER	DESCRIPTION	SIZE	EACH	12/EA
A30019-1009	Square	9"	\$11.99	\$10.75
A30019-1012	Round	12"	17.89	16.10
A30019-9014	Round	14"	22.95	20.65

B Solid Maple Slab Roller

24"L x 3"Dia for quick production of clay slabs. Kiln-dried maple, treated with linseed oil.

NUMBER	EACH	6/EA
A30323-1024	\$31.38	\$28.25

C SlabMat®

A smooth, non-woven alternative to canvas for rolling out slabs of clay. Use with a slab roller, or for rolling out slabs with a rolling pin. It can also be used as a hand-building mat. Available as a single sheet. For use with a slab roller, purchase two sheets. SlabMat can also be cut to custom sizes with a blade and straight edge.

NUMBER	DESCRIPTION	SIZE	EACH	12/EA
A84901-1001	Small	14" x 16"	\$6.92	\$6.29
A84901-1002	Large	16" x 22"	11.78	10.49
A84901-1003	Standard	22" x 50"	25.99	23.63

D Rolling Pins

These solid wood rolling pins suit a variety of projects and hand sizes, and can be used on all types of clay. Available in 8" long, 10" long, or Junior 6" size. 12" long lightweight non-stick rolling pin has a Teflon surface.

NUMBER	DESCRIPTION	SIZE	EACH	12/EA
A30345-1006	6" Wooden		\$7.99	\$7.21
A30345-1008	8" Wooden		11.78	10.61
A30345-1010	10" Wooden		19.45	17.51
A30345-0000	12" Non-Stick		18.15	16.34

E Blick® Wheel Thrower's Apron

This lightweight, long-wearing, dark denim apron is crafted for comfort. Convenience features include a large 9" x 7" chest pocket, extra-long leg splits with calf ties, and an adjustable neck loop for proper fit. Machine-washable. 45"L x 29"W.

NUMBER	EACH	12/EA
A32948-5910	\$22.92	\$20.63

F Richeson® Handled Bats

These tempered hardboard bats are useful for moving clay work or papier mâché around the studio or classroom. They're also useful for transporting pots off the wheel onto the drying rack and for squaring up wheel-thrown pots. They measure 8" x 8" and have a non-stick surface. Handy bulk pack includes 12 bats.

NUMBER	EACH	6/EA
A30287-1088	\$68.82	\$61.93

G Blick® Formica Modeling Boards

Smooth Formica laminated to a composition board, 3/4" thick. Rubber feet prevent slipping and marring tabletops. Factory-direct prices to give you the best value possible!

NUMBER	DESCRIPTION	SIZE	EACH	12/EA
A32927-1004	12" x 12" x 3/4"		\$9.56	\$8.61
A32927-1006	12" x 15" x 3/4"		10.70	9.63
A32927-1007	15" x 18" x 3/4"		11.79	10.62

H Amaco® Canvas-Covered Board

A portable, canvas-covered work surface that's great for wedging and rolling hard clay. Moist clay won't stick to the canvas. Measures 10" x 10".

NUMBER	DESCRIPTION	MEASUREMENT	EACH	12/EA
A32979-1010	Single Board		\$17.31	\$15.58
A32979-1110	Set of 10		164.04	147.63



I Xiem™ X-Board™ Wedging Board

Prep your clay for the pottery wheel on the Xiem X-Board Wedging Board. It has a galvanized steel handle for easy portability, a durable, non-skid rubber base, and a canvas surface.

NUMBER	DESCRIPTION	SIZE	EACH
A30290-1009	18" x 24"		\$66.09
A30290-1002	24" x 24"		82.65
A30290-1013	24" x 32"		93.65

I North Star™ Slab Roller

Sturdy and professional, yet safe for even elementary classrooms!

Two driven rollers measure 2-1/2" Dia x 24"L. Clay is sandwiched between canvas strips then cranked into the machine, where knurled rolls grip canvas and pull slabs through easily. Wet slabs can be moved on the bottom canvas. Two-roll system assures the least amount of warping in the kiln. Infinite thickness adjustment from 0" to 2-1/2" with no shims or boards. Accepts texturing materials and press molds, and makes tapered slabs. Roll opening and handle can be locked in place. Five-year warranty. Includes canvas and mounting hardware. Weighs 35 lb. FOB Factory. See page 648 for details.

NUMBER	DESCRIPTION	EACH
AF30203-1024	Slab Roller	\$640.00
A30203-1001	Tabletop — (not shown)	179.51

J North Star™ PortaRoller

Designed for ceramic arts teachers who move from classroom to classroom, and for studio potters with limited space, the PortaRoller easily breaks down for transport or storage. Its two rollers turn together to pull clay slabs up to 16" wide through with ease. The vertical adjustment of the top roller provides an easy-to-set and infinitely adjustable thickness. Make very thin, translucent porcelain slabs up to thick, heavily textured architectural slabs, with a minimum of warping, curling, or cracking. Press molds and other texturing materials such as burlap, plant materials, rope, cork, and bark can also be passed through in either direction. Rust-resistant and virtually maintenance-free.



NUMBER	EACH
A30257-9000	\$672.00



Amaco® Wedging Board

Constructed of pine with a polyurethane finish. Two recessed areas, 10" x 12" x 1-3/8" deep, filled with absorbent plaster. Canvas wedging cloth snaps firmly over one area. Fine steel cutting wire is held taut by turnbuckle. Overall size: 14"H x 21-7/8"W x 14"D. FOB Factory. See page 648 for details.

NUMBER	EACH
AF30214-1008	\$467.00

K brent® Clay Extruder HD

This solid welded steel clay extruder features an exclusive brent safety design, with two sets of clutch plates that lock the clutch body assembly firmly in place at any height setting for maximum leverage. Heavy-duty 4" diameter barrel holds up to 10 lb of clay; easy-to-use cap holds die in place. Includes three mounting brackets and hardware to securely mount it to the wall. One-year warranty. 46 lb. FOB Factory. See page 648 for details.

NUMBER	EACH
AF30264-1003	\$692.00

Die Set — Three-piece plastic die set makes seven different extruded shapes and includes a selector disk. Dies are 4" in diameter and fit both brent Clay Extruder models. For Hollow Die Set, visit DickBlick.com. FOB Factory. See page 648 for details.

NUMBER	EACH
AF30264-2003	\$47.99

Table Mount — Enables mounting to a table or work bench when wall mounting is not an option. Uses a simple angled brace to maintain vertical stability. Requires drilling three holes in the table or bench. FOB Factory. See page 648 for details.

NUMBER	EACH
AF30264-1001	\$190.50

Slab Roller Mount — Enables mounting to a slab roller when wall mounting is not an option, taking advantage of the strength and stability of the slab roller legs and cross-brace. Use the existing holes that hold down the canvas on the slab roller to attach the Slab Roller Mount.

NUMBER	EACH
A30264-1101	\$211.29

L Bailey™ 4 Hand Clay Extruder

Recommended for solid clay shapes up to 3" in diameter round tubes or 3-3/4" wide slabs. Barrel capacity is 11 lb. Features a square barrel, heavy-duty quick-change die holder, and a plunger stop to protect die braces. Mount on wall or table. Includes mounting hardware, a coil die, two blank dies, and instructions. FOB Factory. See page 648 for details.

NUMBER	EACH
AF30234-1001	\$474.00

Optional Die Kit — 15-piece die kit includes an assortment of square, round, and octagonal tube shapes, plus a multiple coil die and adjustable slab die. FOB Factory. See page 648 for details.

NUMBER	EACH
AF30234-1009	\$143.15

M Debcor™ Wedging Board

Heavy-duty steel 20" x 24" x 2-1/2" with 480 sq. in. of wedging area! Height adjusts from 30" to 36". Includes a fine steel cutting wire and "snap-on" canvas wedging cloth. Plaster not furnished. Dark brown finish. FOB Factory. See page 648 for details.

NUMBER	DESCRIPTION	EACH
AF30237-8030	Board w/Stand	\$641.00
AF30208-8031	Board Only	240.65
AF30237-8040	Stand Only	312.00



N Bailey™ Mini-Might II Slab Roller

A fantastic tool for professionals and hobbyists. The enclosed mechanism makes operation safe for all ages. Both the 16" and 22" models can be used on top of an existing table, and the rubber feet holds them in place. Features include a painted steel frame with size guides, melamine counters, carbide-coated rollers, a 15" crank handle, and one slab sheet. Maximum slab dimension is 16" x 18" on the 16" model; 22" x 24" on the 22" model. The 22" model converts to a 33"H free-standing unit with the leg set (sold separately). FOB Factory. See page 648 for details.

NUMBER	DESCRIPTION	EACH
AF30249-1016	16" Mini-Might II	\$455.00
AF30249-2016	16" Slab Sheet	11.45
AF30249-2022	22" Slab Sheet	13.53
AF30249-1022	22" Mini-Might II	569.00
AF30249-1002	22" Mini-Might II Roller with Legs	840.00



Shimpo® Handheld Extruder

Ideal for adding decorative elements to ceramic work, the Shimpo Handheld Clay Extruder has a 2-1/4" diameter barrel, and includes five stainless steel multi-shaped dies and one blank.

NUMBER	DESCRIPTION	EACH
A30291-1005	Extruder	\$63.59
A30291-1008	8 Hollow Dies	44.90
A30291-1009	9, 4-in-1 Dies & Block Out Die	47.39

O brent® Slab Rollers

A circular handle moves the roller through a double cable system with cast iron mounted ball bearings for complete rigidity. Canvas-covered boards make picking up rolled slabs easy. Masonite sheet bed thickness can be adjusted from 1/4" to 1-3/4". Heavy-duty steel pipe construction. The SR-14 produces 14" x 36" slabs; the SR-20 produces 20" x 52" slabs; the SR-36 produces large 36" x 52" slabs.

NUMBER	DESCRIPTION	EACH
A30241-1114	SR 14 with Legs	\$2750.00
AF30241-1020	SR-20 Floor Model	2870.00
AF30241-1036	SR-36 Floor Model	4200.00

P brent® SRC Slab Rollers

A patented cable drive system with opposing rollers produces even pressure along the bed. Portable, yet extremely sturdy, the basic SRC Slab Roller can fit on a table (or add optional 36" tall legs to turn it into a floor model). Or choose the model that includes legs. Both produce slabs 21"W x 40"L, from 1/4" to 1-1/4" thick, and include six shims. One-year limited warranty. \$70 in Amaco lead-free glazes with purchase. FOB Factory. See page 648 for details.

NUMBER	DESCRIPTION	EACH
AF30213-1000	SRC Slab Roller w/Legs	\$1510.00
AF30213-0200	Canvas Cover Shims	74.50

SRC Slab Roller Handle — An ergonomic round handle for two-handed operation, increased torque, and more continuous movement. Welded steel. FOB Factory. See page 648 for details.

NUMBER	EACH
AF30213-0300	\$233.99

Mini SRC Slab Roller — Includes one 1/4" and two 3/4" thick shims. Rolls slabs up to 14"W x 15"L and 3/4" thick. Weighs 63 lb. Truck Shipment and FOB Factory. See page 648 for details.

NUMBER	EACH
AF30230-0000	\$890.00



A Bailey™ De-Airing Pugmills

Bailey pugmills are designed to make it virtually impossible to injure your fingers or hands. The unique direct vertical plunger drives the clay into the large 4-1/2" x 4-1/2" hopper. A permanent stainless steel safety grid prevents hands from reaching the auger blades without compromising the pugging process. A key-locked safety switch prevents unauthorized operation. The A-400 (shown with optional mobile table) features a 1/2 HP motor, 1/2 HP vacuum pump, 2-3/4" diameter nozzle and can process 400 lb of clay per hour de-aired or 500+ lb per hour non-de-aired. The A-800 features a 1 HP motor, 3/4" vacuum pump, 3" diameter nozzle and can process 800 lb of clay per hour de-aired or 900+ lb per hour non-de-aired. For additional product details, visit DickBlick.com. Truck Shipment and FOB Factory. See page 648 for details.

NUMBER	DESCRIPTION	EACH
AF30248-0400	A-400	\$4350.00
AF30248-0800	A-800	4455.00
AF30248-1001	Table	540.00



Shimo® Pugmill

This pugmill's high-quality wedging function features stainless steel twin augers typically found in larger industrial machines. They increase the wedging capacity and produce practically air-free clay (up to 880 lb per hour) without a vacuum. The forceful, direct gear-driven motor provides maximum mechanical force with minimal operator effort. A safety limit switch automatically cuts power to the pugmill when the augers are exposed. A stop button allows for immediate operator control. A compact design with a removable case allows easy access to the mixing chamber for fast and easy cleanup and maintenance. One-year manufacturer's warranty. 25-1/2" x 12" x 22-1/2" with a 3-1/2" x 3-1/2" hopper. 1/4 HP, 60 Hz, 115V, AC. FOB Factory. See page 648 for details.

NUMBER	EACH
AF32943-0000	\$3495.00



B Debcor™ Combo Cabinet

A great group instruction center or workstation! Separate cabinets are joined by an overlaid 1-1/4" thick, 20" x 72-1/2" moisture-resistant laminated top. Damp Cabinet (31"H x 36"W x 19"D) keeps works in progress workable and features a double-walled exterior, aluminum interior, airtight doors, and two bolt-on shelves. Drying Cabinet (31"H x 36"W x 19"D) dries, protects, and stores greenware and features steel mesh walls, with two perforated steel shelves for effective circulation. Overall dimensions with top: 32-1/4"H x 72-1/2"W x 20"D. Weighs 340 lb. Truck Shipment and FOB Factory. See page 648 for details.

NUMBER	EACH
AF30244-0000	\$3199.00

C Debcor™ Ceramic Work Table

Sturdy, all-purpose work table, available in a variety of sizes. Height is adjustable. Formica top resists liquids and is easily cleaned. Ideal for ceramic workshops, studios, and labs. Truck Shipment and FOB Factory. See page 648 for details.

NUMBER	TOP SIZE	SHPG WT	EACH
AF30206-1006	24" x 48"	81 lb	\$602.00
AF30206-1024	24" x 60"	98 lb	643.00
AF30206-1124	24" x 72"	113 lb	700.00
AF30206-1106	30" x 48"	97 lb	633.00
AF30206-1008	30" x 60"	118 lb	686.00
AF30206-1108	30" x 72"	138 lb	764.00
AF30206-1009	30" x 96"	184 lb	1078.00

PRODUCT REVIEWS
are a great way to share
your opinions with others as
well as find the products
that best meet your needs!



To learn more, visit
[DickBlick.com/
productinfo/reviews](http://DickBlick.com/productinfo/reviews)



D Debcor™ Drying Cabinet

Designed for drying and storing or to protect other special pieces from damage. Locking cabinet of heavy-gauge steel angles welded to expanded steel mesh walls. Steel top and bottom pans are solidly welded and reinforced for heavy-duty service. Unit has four large shelves constructed of steel and perforated board. Design provides effective circulation throughout the cabinet. 83"H x 36"W x 19"D. Dark Brown/Antique Gold. Weighs 200 lb. Truck Shipment and FOB Factory. See page 648 for details.

NUMBER	EACH
AF30218-1103	\$2486.00

Small Debcor Drying Cabinet — Same as above only with two shelves. 31"H x 36"W x 19"D. Weighs 140 lb. Truck Shipment and FOB Factory. See page 648 for details.

NUMBER	EACH
AF30218-1003	\$1299.00

E-F Debcor™ Damp Cabinet

Designed to keep "works in progress" in moist, workable condition. Spacious body is steel with foam angle supports. Cabinet is "air sealed" by foam gasketed doors. Locking door and exterior walls are double walled with an internal layer of aluminum. Unit has four large bolt-on shelves with aluminum surface and water-retaining bats. Approximately 83"H x 36"W x 18"D. Dark Brown/Antique Gold finish. Weighs 275 lb. Truck Shipment and FOB Factory. See page 648 for details.

NUMBER	EACH
AF30221-1003	\$3275.00

Small Debcor Damp Cabinet — Two shelves. 31"H x 36"W x 19"D. Weighs 150 lb. Truck Shipment and FOB Factory. See page 648 for details.

NUMBER	EACH
AF30221-1001	\$1572.00



G Brent™ Batmobile

This durable steel cart on 4" diameter rubber swivel casters stores up to 90, 14" bats, with adjustable shelves that can be used to store both 12" and 14" bats. The powder-coated frame resists scratches and corrosion. Bats not included.

NUMBER	EACH
A32952-1047	\$607.00

H Rubbermaid™ Brute™ Clay Container

This 20-gallon container features outstanding strength and durability. Seamless construction for easy cleaning. Extremely resistant to cracking, acids, chemicals, scratches, and more. Won't leak, rust, or corrode. Ideal for storing wet or dry clay. Ribbed bottom increases stability and improves dragging capability. Built-in hand grips. Gray with lid. 22-7/8"H x 19-1/2"Dia.

NUMBER	EACH
A30209-1020	\$49.74

I Duramold™ Dolly

Twist-on, twist-off dolly provides mobility for clay container, above. Five casters for greater stability.

NUMBER	EACH
A30209-0000	\$93.44

J Extra Heavy-Duty Service Carts

These heavy-duty carts are built to withstand demanding use in studios and classrooms. Their tough steel trays have 3" deep mitered flanges for an 800 lb capacity. Trays can be inverted to form a flat-top work surface. The carts are coated with a rust-resistant, baked, phosphatized, and bonderized gray enamel finish. The push handles are made of tubular steel. Both carts maneuver easily on 5" x 1-1/4" wobble-free casters (2 rigid, 2 swivel). Stands 32" high. Assembly required.

NUMBER	SIZE	EACH
A30228-1001	30" L x 16" W x 32" H	\$208.78
A30228-1005	36" L x 24" W x 32" H	254.86

K Rubbermaid™ Service Cart

Solid Duramold construction won't chip, dent, or flake, never needs painting, and is easy to clean. No sharp edges to nick or scrape walls and doors. Two fixed wheels, two swivel casters, cup holder, and storage bin. Load capacity up to 500 lb. Beige.

NUMBER	SIZE	EACH
A30229-8148	30"H x 16"W	\$376.00
A30229-8145	36"H x 24"W	437.00

L Debcor™ Heat-Proof Kiln Cart

Mobility and safety are the prime features of this sturdy kiln cart. Made of heavy-gauge steel. Includes three heat-proof, non-asbestos millboard panels that fit inside the trays. 5" diameter wheels with two swivel casters. Size 32"H x 36"W x 24"D. Weighs 80 lb. FOB Factory. See page 648 for details.

NUMBER	EACH
AF30219-1005	\$682.00



M Bailey™ Ware Cart

With 13 or 26 shelf divisions, these carts are more versatile than any other racks available. Constructed of heavy-duty angle iron with centers of 5" between divisions. Ideal for dinnerware or tiles. 6" casters. 13-division cart has 5" between shelves; 26-division cart has 2-1/2" between shelves. Both are 74-1/4"H x 34-1/2"W x 24"D. Shelf boards sold separately. Truck Shipment and FOB Factory. See page 648 for details.

NUMBER	DIVISION	EACH
AF30233-1013	13 Shelves	\$890.00
AF30233-1026	26 Shelves	1250.00

Shelf Boards — FOB Factory. See page 648 for details.

NUMBER	SIZE	EACH
AF30233-1012	12" x 32"	\$18.99
AF30233-1024	24" x 32"	35.99

N Brent™ Ware Cart EX

Heavy-duty, steel-frame cart constructed from 1" heavy-wall pipe. 72-3/4"H x 35"W x 24"D. Shelves are optional (see below). Shipped unassembled; assembles in only five minutes. Features four locking casters. Includes plastic cover. Weighs 95 lb. One-year warranty. Truck Shipment and FOB Factory. See page 648 for details.

NUMBER	EACH
AF30205-1008	\$787.00

Optional Shelves — Made from 1/2" exterior grade plywood. 12" x 32". Set of 12. Weighs 47 lb. FOB Factory. See page 648 for details.

NUMBER	EACH
AF30205-1009	\$164.29

O North Star™ Shelf Truck

Most versatile ware truck available for classroom or studio. Features big 6" industrial wheels for easy rolling. Two parking brakes. 1000 lb capacity. Can carry ceramic ware, kiln furniture, clay, and more. All shelves instantly adjustable on 2" centers. Holds as many as 23 shelves. Can use full shelves (24" x 36"), half shelves (12" x 36"), even oversize shelves of plywood, particleboard, and more. All-steel construction. Comes complete with four pairs of shelf brackets (yielding five shelf levels). Overall size: 66"H x 39"W x 29"D. Ships in two cartons. Two-year warranty. FOB Factory. See page 648 for details.

NUMBER	EACH
AF30204-0000	\$585.00

Set of 5 Shelves — Full size. FOB Factory. See page 648 for details.

NUMBER	EACH
AF30204-1009	\$182.59

P Debcor™ Ware Truck

Versatile truck of heavy-gauge steel, welded construction on 4" casters. Great for cooling ware after firing or just moving pieces from place to place. Can also be used for drying greenware. Twelve plywood "half-shelves," each measuring 1/2"H x 28"W x 12"D, for maximum flexibility. Dark brown finish. Overall size: 54"H x 24"W x 32"D. Weighs 116 lb. FOB Factory. See page 648 for details.

NUMBER	DESCRIPTION	EACH
AF30207-8034	With Shelves	\$804.00
AF30207-1001	Without Shelves	656.00

what you should know before buying a kiln

A kiln is an important purchase for school or studio — one that the purchaser will live with for many years to come. Considering that it's an important investment, buying one can be a daunting task. Here are a few points that will help you make the right choice for your application and budget.

Q. Where will the kiln be located?

A. First, you must decide where your kiln is going to be installed. For a school, that might be in the classroom or in the boiler room. In a studio, where space selection is more limited, the size of the available area will help determine the size of the kiln. But the following points remain constant:

1. Kilns should be located in a separate, well-ventilated room other than in an immediate work area.
2. Never install a kiln on any combustible floor such as wood or carpet.
3. The spacing between the kiln and wall must be a minimum of 18" regardless of what room it's in.

4. Measure carefully to make sure the kiln will fit through all doors leading to the placement location. Sectional kilns can be easily taken apart to fit through narrow doorways or staircases.

A CAREFUL CHECK BY A QUALIFIED ELECTRICAL OR THE LOCAL POWER COMPANY IS RECOMMENDED.

Q. What power is available at your location?

A. It is important to check with maintenance personnel or a professional electrician to find out the following electrical information for the destination of placing your kiln.

Voltage — Voltage services can be 120V, 208V or 240V. Most residences only have 120V and 240V, whereas commercial and institutional buildings may have all three available. It is important to check the voltage available in the area where the kiln will be located as different buildings may have different supplies. Some 240V kiln models will have a higher temperature rating.

Phase — All 208V and 240V service will be either single-phase or three-phase. Nearly all residential service is single-phase, whereas commercial and institutional services may have both available. Single-phase has two current-carrying wires and a ground and three-phase has three current-carrying wires and a ground. They are both equally efficient; however, three-phase supplies allow for smaller wire and some kiln models designed for three-phase will have higher temperature ratings.

Amps — The kiln size you are considering could determine the amperage supplied to the building. Additional amperage may be added to the location by expanding the existing service. Again, refer to your maintenance personnel or electrician to determine the existing amps that are supplied.

Q. What is the maximum temperature you will require?

A. It depends on what type of clay and glazes will be fired in the kiln. Whether you

use high or low fire clays will help determine the maximum temperature for your needs.

Clay — High Fire — Cone 5 (2167°F) and higher
Low Fire — Cone 05-06 (1828°F-1888°F)

Glazes — High Fire — Cone 5 (2167°F) and higher
Low Fire — Cone 04-05 (1888°F-1945°F)

Q. What is the maximum chamber size required?

A. The quantity of pieces you want to fire at one time and the size of the artwork being produced must be evaluated to determine maximum chamber size. Keep in mind the volume of work that will need to be fired in busy months.

Q. What safety measures should be taken when firing?

A. Always be present during the end of the firing cycle and cool-down period, to prevent over-firing. The kiln surface emits heat. Do not install near combustible surfaces or under a sprinkler head. Do not touch the surface while firing — wait until cooled to 130°F before opening the lid and always wear heat-resistant gloves.

Q. What is the recommended procedure for firing with a manual kiln?

1. Place the correct jr. cone in the kiln sitter and set the falling weight.
2. Set the timer to 30 minutes past the anticipated firing time.
3. Prop the lid if kiln is not equipped with a downdraft vent.
4. Turn switches to LOW.
5. Two hours later, turn switches to MEDIUM.
6. Two hours later, remove the prop with a gloved hand and turn the switches to HIGH.
7. The kiln will shut off automatically when the proper heatwork has been achieved.

Q. What are the advantages of an automatic kiln?

A. An automatic controller allows the user to create precise, repeatable schedules. This provides consistent results, or more creative control when experimenting. Delay and auto shut-off features increase convenience and safety.

Q. Why vent a kiln?

A. Fumes, odors, and vapors are created when clay bodies and glazes are fired. It is important to clear them out of inhabited spaces for the comfort and safety of those around. Additionally, the venting process affects the firing results. A venting hood will dispel most of the fumes as they escape the kiln. Mechanical downdraft systems improve consistent heat distribution and circulation, as well as remove fumes before they can enter the room, or transfer color from one glaze to another inside the kiln.

Q. Why is it important to have air in the kiln?

A. Clay bodies, glazes, decals, lusters, etc. need air to fire properly. Many problems with color, glaze fit, and porcelain mildew occur because of too little oxygen in the kiln.

Q. What happens to air in the kiln?

A. The products we fire contain carbon and organics. These react with oxygen to form

carbon monoxide early in the firing. During firing, the gases in the kiln expand — just like air in a hot air balloon. These gases are forced out through cracks and holes, making it difficult for new air to enter the kiln. A downdraft vent system pulls out the fumes, allowing fresh air to enter.

Q. Are there any health and safety issues?

A. Testing has shown that carbon monoxide produced during firing can be higher than accepted government (OSHA) standards. [35 PPM (0.0035%) for continual exposure or 200 PPM for short term exposure.] Carbon monoxide can produce headaches, fatigue, sore throats, and nausea. Fumes from kilns may also contain organics, volatile metals, fluorides, and sulphur oxides, which should be removed from the work area.

Q. What's the difference between a downdraft vent and a hood?

A. A downdraft vent removes fumes and odors from the kiln while at the same time bringing in air to improve firing conditions in the kiln. A hood system does not vent the kiln. It simply removes fumes that have already entered the room. There are no firing benefits, and only about 85% of the fumes are removed. Conditions in the kiln are not improved with hoods.

Q. What are some of the benefits of a downdraft vent?

A. Air brought into the kiln replaces carbon monoxide and adds oxygen needed for best fired results.

Hot gases are circulated, providing more uniform temperatures.

Oxygen in the kiln reduces corrosion of metal heating elements and kiln sitter parts, increasing their life.

A downdraft vent costs less than two cents per hour to operate. It requires 80% less makeup air than a hood above the kiln and saves up to \$1.00 per day for heating or cooling makeup air as compared to a hood.

Manual venting is eliminated — no more touching the hot kiln to lower the lid or replace peephole plugs. The kiln stays closed throughout the firing and cool down is quicker (4-10 hours less) without opening the lid.

Downdraft venting is much more effective than a hood in removing fumes. It does not significantly increase firing time or affect the ability of the kiln to reach temperature.

Most kiln manufacturers recommend and sell downdraft venting. It is easily installed with no overhead pulleys.

ONLY DOWNDRAFT VENTING IMPROVES FIRING CONDITIONS IN THE KILN WHILE REMOVING FUMES FROM THE KILN AND WORKROOM!

AMACO® ROUND EXCEL® KILNS: premium features are standard

- Two-year warranty.
- Designed for high-fire and low-fire work.
- Toll-free technical support.
- Select Fire™ Automatic Kiln Controller for easy operation.
- Top-quality components.
- Kanthal A-1 heating elements provide long life.
- Includes instructional DVD.
- Up to \$100 Amaco glaze rebate included.
- Truck shipment and FOB Factory. See page 648 for details.



Underwriters Laboratories

EX-257/EX-353

Easy-loading design. Each kiln is configured and built to order. Therefore, kilns are not returnable. FOB Factory. See page 648 for details.

Model EX-257 with 2-1/2" Fire Brick — Shipping Weight 270 lb.

NUMBER	PHASE	VOLTS	AMPS	TEMP.	EACH
AF30191-2508	1	208	48	Cone 10	\$3500.00
AF30191-2540	1	240	34.6	Cone 10	3500.00
AF30191-2608	3	208	48	Cone 10	3500.00
AF30191-2640	3	240	34.6	Cone 10	3500.00

Model EX-353 with 3" Fire Brick — Shipping Weight 300 lb.

NUMBER	PHASE	VOLTS	AMPS	TEMP.	EACH
A30191-3508	1	208	48	Cone 10	\$4455.00
AF30191-3540	1	240	34.6	Cone 10	4455.00
AF30191-3608	3	208	48	Cone 10	4455.00
AF30191-3640	3	240	34.6	Cone 10	4455.00

EX-270/EX-365

Best-selling size. Each kiln is configured and built to order. Therefore, kilns are not returnable. FOB Factory. See page 648 for details.

Model EX-270 with 2-1/2" Fire Brick — Shipping Weight 290 lb.

NUMBER	PHASE	VOLTS	AMPS	TEMP.	EACH
AF30124-2050	1	208	48	Cone 6	\$3955.00
AF30124-2060	1	240	48	Cone 10	3955.00
AF30139-2070	3	208	31.7	Cone 10	3955.00
AF30139-2080	3	240	29.3	Cone 10	3955.00

Model EX-365 with 3" Fire Brick — Shipping Weight 320 lb. FOB Factory. See page 648 for details.

NUMBER	PHASE	VOLTS	AMPS	TEMP.	EACH
AF30174-2081	1	208	48	Cone 10	\$4480.00
AF30174-2201	1	240	48	Cone 10	4480.00
AF30174-2082	3	208	31.7	Cone 10	4480.00
AF30174-2202	3	240	29.3	Cone 10	4480.00

EX-399/EX-1099

Best volume-to-price ratio. Each kiln is configured and built to order. Therefore, kilns are not returnable. FOB Factory. See page 648 for details.

Model EX-399 with 3" Fire Brick — Shipping Weight 400 lb.

NUMBER	PHASE	VOLTS	AMPS	TEMP.	EACH
AF30124-1100	1	208	48	Cone 5	\$4790.00
AF30124-0900	1	240	48	Cone 8	4790.00
AF30124-1200	3	208	31.7	Cone 8	4790.00
AF30139-1010	3	240	29.3	Cone 8	4790.00

Model EX-1099 with 3" Fire Brick — Shipping Weight 410 lb. FOB Factory. See page 648 for details.

NUMBER	PHASE	VOLTS	AMPS	TEMP.	EACH
AF30124-9004	1	208	69	Cone 10	\$5591.00
AF30124-0100	1	240	60	Cone 10	5591.00
AF30139-3000	3	208	46.7	Cone 10	5591.00
AF30139-3001	3	240	40	Cone 10	5591.00

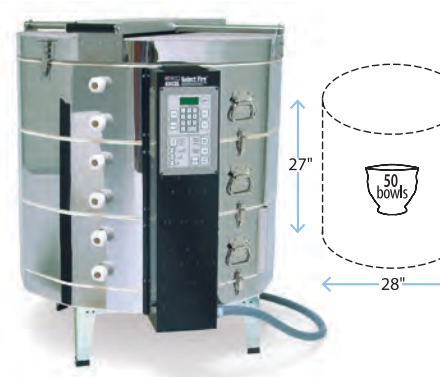
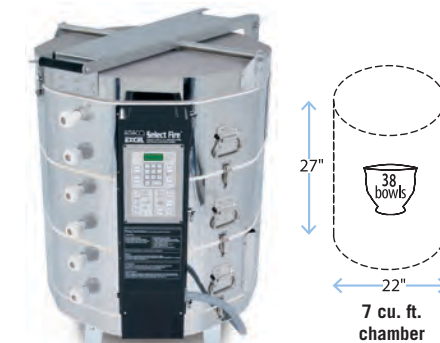

Two-Position Reinforced Steel Bar
Secures lid while loading and unloading kiln.

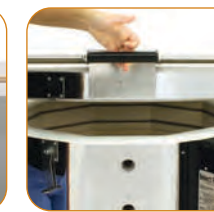

EZ-Lift Lid
A spring-assisted hinge, so you can lift it with one finger.



Corrosion-Resistant LUG Connectors
Replace elements using a screwdriver. No soldering, no wire cutting required.



Sectional Design
Makes transporting, changing locations, or repairing easy.



Amaco® Master KilnVent

This effective and economical vent works with all Amaco kilns. It mounts to the wall, then connects to the side or back of the kiln to vent either one large or two small kilns. Easy to install and operates from a standard 120V outlet. Two-year warranty. FOB Factory. See page 648 for details.

NUMBER	DESCRIPTION	EACH
AF30186-1001	Master KilnVent	\$612.00



Amaco® Excel® Kiln Furniture Kits

These furniture kits include a recommended number of shelves and post assortment, plus kiln wash.

NUMBER	DESCRIPTION	EACH
A30122-0700	For EX-226, EX-232, EX-324, EX-329	\$351.00
A30122-0800	For EX-344, EX-353, EX-365	494.00
A30122-0900	For EX-247, EX-257, EX-270	440.00
A30122-1000	For EX-399, EX-1011, EX-381, EX-1266	790.00

SKUTT KILNS

find out why Skutt is the #1 selling kiln in America



- Hand-selected brick for uniform insulation.
- Spring-assisted lid for safe, effortless opening.
- Smart materials, including long-lasting relays.
- Balanced elements for even heat.
- Two-year warranty includes parts and labor.
- Standard controller comes with most features available on the Touch Screen controller but does not include WIFI, an APP for remote viewing, or help screens. Visit DickBlick.com for more details.



Each kiln is configured and built to order. Therefore, kilns are not returnable. Truck Shipment and FOB Factory. See page 648 for details.

											POWER	TEMPERATURE	CHAMBER	PRICE WITH STANDARD KILNMASTER CONTROLLER		PRICE WITH KILNMASTER TOUCH SCREEN	
Budget Starter Kilns																	
MODEL	PHASE	VOLTS	AMPS	WATTS	CONE	TEMP.	CU. FT.	OPENING	DEPTH	WEIGHT	NUMBER	EACH	NUMBER	EACH			
614-3" 714	1	115V 208/240V	20	2300	6 8	2250°F 2300°F	0.8 1.4	11" 14.38"	13.5"	88 lb	AF30117-1600	\$1600.00	AF30286-1043	\$1922.00			
Small Studio Favorites																	
MODEL	PHASE	VOLTS	AMPS	WATTS	CONE	TEMP.	CU. FT.	OPENING	DEPTH	WEIGHT	NUMBER	EACH	NUMBER	EACH			
818	1	208V	26.7	5550	10	2350°F	2.6	17.5"	18"	142 lb	AF30117-1100	\$2028.00	AF30286-1108	\$2350.00			
818-3"	1	240V	27.8	6660	10	2350°F	2.6	17.5"	18"	142 lb	AF30117-1200	2028.00	AF30286-1008	2350.00			
818-3"	1	208V	26.7	5550	10	2350°F	2.3	16.5"	18"	160 lb	AF30117-1300	2116.00	AF30286-1308	2438.00			
818-3"	1	240V	27.8	6660	10	2350°F	2.3	16.5"	18"	160 lb	AF30117-1400	2116.00	AF30286-1208	2438.00			
822	1	208V	38.5	8000	10	2350°F	3.2	18"	22"	170 lb	AF30117-2400	2189.00	AF30286-1122	2511.00			
822	1	240V	33.4	8000	10	2350°F	3.2	18"	22"	170 lb	AF30117-2300	2189.00	AF30286-1022	2511.00			
Easy to Load																	
MODEL	PHASE	VOLTS	AMPS	WATTS	CONE	TEMP.	CU. FT.	OPENING	DEPTH	WEIGHT	NUMBER	EACH	NUMBER	EACH			
1018	1	208V	40	8320	10	2350°F	4.6	23.38"	18"	196 lb	AF30117-0000	\$2842.00	AF30286-1118	\$3164.00			
1018	1	240V	39.4	9460	10	2350°F	4.6	23.38"	18"	196 lb	AF30117-0100	2842.00	AF30286-1018	3164.00			
1018-3"	1	208V	40	8320	10	2350°F	4.2	22.38"	18"	223 lb	AF30117-0200	2944.00	AF30286-1318	3266.00			
1018-3"	1	240V	39.4	9460	10	2350°F	4.2	22.38"	18"	223 lb	AF30117-0300	2944.00	AF30286-1218	3266.00			
1022	1	208V	48	9984	10	2350°F	5.7	23"	22"	240 lb	AF30117-2200	3155.00	AF30286-3122	3477.00			
1022	3	208V	34.6	9984	10	2350°F	5.7	23"	22"	240 lb	AF30118-1100	3864.00	AF30286-3322	3546.00			
1022	1	240V	48	11520	10	2350°F	5.7	23"	22"	240 lb	AF30117-2100	3155.00	AF30286-3022	3477.00			
1022	3	240V	34.6	11520	10	2350°F	5.7	23"	22"	240 lb	AF30118-1000	3864.00	AF30286-3222	3546.00			
1222-3	1	208V	48	9984	8	2300°F	8.1	28"	22"	330 lb	AF30117-2000	3795.00	AF30286-2122	4117.00			
1222-3	1	240V	48	11520	10	2350°F	8.1	28"	22"	330 lb	AF30117-1900	3795.00	AF30286-2022	4117.00			
1222-3	3	240V	34.6	11520	10	2350°F	8.1	28"	22"	330 lb	AF30118-0800	3864.00	AF30286-2222	4186.00			
1222-3	3	208V	40	11520	10	2350°F	8.1	28"	22"	330 lb	AF30118-0900	3864.00	AF30286-2322	4186.00			
Powerful and Versatile																	
MODEL	PHASE	VOLTS	AMPS	WATTS	CONE	TEMP.	CU. FT.	OPENING	DEPTH	WEIGHT	NUMBER	EACH	NUMBER	EACH			
1027	3	240V	29.3	11520	10	2350°F	7	23.38"	27"	238 lb	AF30118-0100	\$3519.00	AF30286-2227	\$3841.00			
1027	1	208V	48	9980	6	2350°F	7	23.38"	27"	238 lb	AF30117-0400	3450.00	AF30286-2127	3772.00			
1027	1	240V	48	11520	10	2350°F	7	23.38"	27"	238 lb	AF30117-0500	3450.00	AF30286-2027	3772.00			
1027	3	208V	31.7	11000	10	2350°F	7	23.38"	27"	238 lb	AF30118-0000	3519.00	AF30286-2327	3841.00			
1027-3"	3	208V	31.7	11000	10	2350°F	6.4	22.38"	27"	270 lb	AF30118-0200	3634.00	AF30286-2727	3956.00			
1027-3"	3	240V	29.3	11520	10	2350°F	6.4	22.38"	27"	270 lb	AF30118-0300	3634.00	AF30286-2627	3956.00			
1027-3"	1	208V	48	9980	10	2350°F	6.4	22.38"	27"	270 lb	AF30117-0600	3565.00	AF30286-2527	3887.00			
1027-3"	1	240V	48	11520	10	2350°F	6.4	22.38"	27"	270 lb	AF30117-0700	3565.00	AF30286-2427	3887.00			
1218-3"	3	240V	29.3	11520	10	2350°F	6.6	28.13"	18"	278 lb	AF30118-0600	3588.00	AF30286-2218	3910.00			
1218-3"	3	208V	31.7	11000	10	2350°F	6.6	28.13"	18"	278 lb	AF30118-0700	3588.00	AF30286-2318	3910.00			
1218-3"	1	208V	48	11500	10	2350°F	6.6	28.13"	18"	278 lb	AF30117-1800	3519.00	AF30286-2118	3841.00			
1218-3"	1	240V	48	11500	10	2350°F	6.6	28.13"	18"	278 lb	AF30117-1700	3519.00	AF30286-2018	3841.00			
Production Kilns																	
MODEL	PHASE	VOLTS	AMPS	WATTS	CONE	TEMP.	CU. FT.	OPENING	DEPTH	WEIGHT	NUMBER	EACH	NUMBER	EACH			
1227-3"	1	208V	48	9980	5	2185°F	9.9	28.13"	27"	351 lb	AF30117-0800	\$4158.00	AF30286-1127	\$4480.00			
1227-3"	1	240V	48	11520	8	2300°F	9.9	28.13"	27"	351 lb	AF30117-0900	4158.00	AF30286-1027	4480.00			
1227-3"	3	208V	31.7	11000	8	2300°F	9.9	28.13"	27"	351 lb	AF30118-0400	4227.00	AF30286-1327	4549.00			
1227-3"	3	240V	29.3	11520	8	2300°F	9.9	28.13"	27"	351 lb	AF30118-0500	4227.00	AF30286-1227	4549.00			
1227-3" PK	3	208V	46.7	14300	10	2350°F	9.9	28.13"	27"	360 lb	AF30163-3208	4807.00	AF30286-3327	5129.00			
1227-3" PK	3	240V	40	14300	10	2350°F	9.9	28.13"	27"	360 lb	AF30163-3240	4807.00	AF30286-3227	5129.00			
1227-3" PK	1	208V	69	14300	10	2350°F	9.9	28.13"	27"	360 lb	AF30164-2208	4807.00	AF30286-3027	5129.00			
1227-3" PK	1	240V	60	14300	10	2350°F	9.9	28.13"	27"	360 lb	AF30164-2240	4158.00	AF30286-3127	5129.00			
1231-3" PK	1	208V	80	16640	10	2350°F	11.6	28.13"	31"	398 lb	AF30164-1208	5000.00	AF30286-1331	5322.00			
1231-3" PK	1	240V	72	17300	10	2350°F	11.6	28.13"	31"	398 lb	AF30163-1240	8169.00	AF30286-1231	5322.00			
1231-3" PK	3	208V	51.5	17300	10	2350°F	11.6	28.13"	31"	398 lb	AF30163-2208	5000.00	AF30286-1131	5322.00			
1231-3" PK	3	240V	44.5	17300	10	2350°F	11.6	28.13"	31"	398 lb	AF30163-2240	5000.00	AF30286-1031	5322.00			
1627-3" PK	3	208V	66	23600	10	2350°F	18.5	46 x 30.75"	27"	535 lb	AF30163-1208	8169.00	AF30286-1116	8491.00			
1627-3" PK	3	240V	66	23600	10	2350°F	18.5	46 x 30.75"	27"	535 lb	AF30163-1240	8169.00	AF30286-1016	8491.00			

upgrades

PK Power

- **Increased Power.** Power to fire-dense loads to high-fire temperatures without the kiln slowing down.
- **Built Tough.** Equipped with industrial Mercury Relays and heavy-gauge high temperature wire to handle the added power.
- Shown in chart with a "PK" designation. Standard on KM1627 and KM1231 models. Optional upgrade on KM1227.

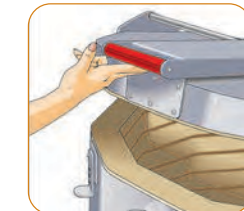

Lid Lifter Upgrade Kit

- **Two-Finger Lifting.** Easily lift your kiln lid with just two fingers. Available as an upgrade for your existing Skutt 10- and 12-sided

kilns. (This feature is now standard on newly purchased 10- and 12-sided Skutt kilns.) FOB Factory. See page 648 for details.

NUMBER	DESCRIPTION	EACH
AF30162-1012	12-Sided Kiln Kit	\$420.00
AF30162-1010	10-Sided Kiln Kit	400.00
AF30162-1103	10-Sided Kit w/3" Brick	400.00



KM-1 Wall Mount Controller

- **Upgrade Your Manual Control Kiln.** Converts KilnSitter manual kilns to the convenience and

precision of an automatic controller.

- **It's Easy!** Easy to install, easy to clean. Mount at eye level for easy monitoring. FOB Factory. See page 648 for details.

NUMBER	DESCRIPTION	EACH
AF30167-1208	Phase 1, 208V	\$955.00
AF30167-1240	Phase 1, 240V	955.00
AF30167-3208	Phase 3, 208V	1010.00
AF30167-3240	Phase 3, 240V	1010.00



Skutt KilnMaster Touchscreen Controller Upgrade

- **Upgrade Your Kiln Master Kiln.** This kit features touchscreen technology that is

super-intuitive and easy to use. A Guided Start feature helps even first-time users successfully enter programs, and an innovative hinge mount allows for positioning the controller to the proper angle for viewing, which eliminates awkward angles when entering programs.

A downloadable app allows for remote temperature monitoring. Help Screens walk users through every procedure.

NUMBER	EACH
A30285-1001	\$604.00



Energy-saving 3" Brick

- **Better Insulation and Energy Savings.** Recommended for high-fire models. High-quality fire brick increases

the temperature rating and slows cooling.

- Shown in chart with a "-3" designation.

accessories

Skutt Replacement Elements

These replacement elements come complete with connectors, pins, and instructions. Specify the voltage and phase of your kiln. FOB Factory. See page 648 for details.

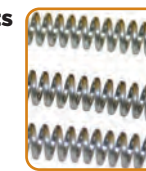

NUMBER	VOLTS	PHASE	QTY IN KILN	LOCATION	EACH
A30118-9012	240	1&3	2	Top/Bottom	\$57.99
A30118-9013	240	1&3	4	Center	57.99
A30115-0100	208	1&3	2	Top/Bottom	57.99
A30118-9004	208	1	4	Center	57.99
A30115-0000	208	3	4	Center	57.99

For Model 1027

NUMBER	VOLTS	PHASE	QTY IN KILN	LOCATION	EACH
A30105-9007	240	1&3	2	Top/Bottom	\$57.99
A30105-9008	240	1&3	4	Center	57.99
A30115-9000	208	1	2	Top/Bottom	57.99
A30115-9015	208	1	4	Center	57.99
A30115-9001	208	3	4	Center	57.99

PARAGON™

Paragon™ Touch-N-Fire Kilns

Feature-packed kilns for every need and budget. All kilns feature easy-access, easy maintenance drop-down switch boxes, and the Sentry controller. Heating is wonderfully even and economical with 3" energy-saving firebrick; and in Cone-Fire mode, selecting Pre-Heat and Slow-Cool is easy, too. Each comes with its own stand, and a full-formed, galvanized steel base covers the brick bottom beneath each kiln for extra safety. Peepholes are tapered for wide view without heat loss. Models 23-3, 24-3, 27-3, and 28-3 feature Paragon's patented LiteLid spring counter-weight and sectional design. The kilns dismantle easily for firing sculptures or moving through narrow doorways. All models listed feature a protective row of 2" high blank bricks lining the top. This reduces brick damage from leaning into the kiln. Specify voltage and phase. Certified to UL & CSA Standard 499. Each kiln is configured and built to order. Therefore, kilns are not returnable. Truck Shipment and FOB Factory. See page 648 for details.

NUMBER	MODEL NO.	FIRES TO CONE TEMP	PHASE	CHAMBER DIA.	CHAMBER DEPTH	VOLT	AMPS	WEIGHS	EACH
AF30149-2402	TNF-82-3	10 - 2350°F	1	16-1/2"	22-1/4"	240V	30	200 lb	\$2306.00
AF30149-2082	TNF-82-3	10 - 2350°F	1	16-1/2"	22-1/4"	208V	35	200 lb	2376.00
AF30149-2403	TNF-23-3	10 - 2350°F	1	22-1/2"	22-1/4"	240V	40	295 lb	3089.00
AF30149-2083	TNF-23-3	10 - 2350°F	1	22-1/2"	22-1/4"	208V	46	295 lb	3089.00
AF30149-2404	TNF-24-3	10 - 2350°F	1	22-1/2"	29"	240V	48	335 lb	3604.00
AF30149-2084	TNF-24-3	10 - 2350°F	1	22-1/2"	29"	208V	52	335 lb	3535.00
AF30149-2405	TNF-27-3	10 - 2350°F	1	28"	22-1/4"	240V	48	335 lb	3809.00
AF30149-2085	TNF-27-3	10 - 2350°F	1	28"	22-1/4"	208V	58	335 lb	3809.00
AF30149-2406	TNF-28-3	4 - 2150°F	1	28"	29"	240V	48	415 lb	3827.00
AF30149-2086	TNF-28-3	4 - 2150°F	1	28"	29"	208V	55	415 lb	3944.00
AF30149-3083	TNF-23-3	10 - 2350°F	3	22-1/2"	22-1/4"	208V	46	295 lb	3036.00
AF30149-3084	TNF-24-3	10 - 2350°F	3	22-1/2"	29"	208V	30	335 lb	3607.00
AF30149-3085	TNF-27-3	10 - 2350°F	3	28"	22-1/4"	208V	33	335 lb	3807.00
AF30149-3086	TNF-28-3	4 - 2150°F	3	28"	29"	208V	30	415 lb	3940.00

Paragon™ Furniture Kits

Model TNF-82-3 — Three 15" x 5/8" shelves, one 15" x 5/8" half shelf, 1" square posts include four each of 1/2", 1", 2", 3", 4", 5", 6" lengths, and 1 lb bag of kiln wash. Weighs 34 lb.

NUMBER	EACH
AF30149-0823	\$261.29

Model TNF-23-3 — Six 20" x 3/4" half shelves, 1-1/2" square posts include eight each of 1", 2", 3", 4", 5", 6" lengths, and 1 lb bag of kiln wash. Weighs 77 lb.

Truck Shipment and FOB Factory. See page 648 for details.

NUMBER	EACH
AF30149-0233	\$465.00

Model TNF-24-3 — Eight 20" x 3/4" half shelves, 1-1/2" square posts include eight each of 1", 2", 3", 4", 5", 6" lengths, and 1 lb bag of kiln wash. Weighs 94 lb. Truck Shipment and FOB Factory. See page 648 for details.

NUMBER	EACH
AF30149-0243	\$530.00

Model TNF-27-3 — Six 26" x 3/4" half shelves, 1-1/2" square posts include six each of 1", 2", 3", 4", 5", 6" lengths, and 1 lb bag of kiln wash. Weighs 150 lb.

Truck Shipment and FOB Factory. See page 648 for details.

NUMBER	EACH
AF30149-0273	\$662.00

Model TNF-28-3 — Eight 26" x 3/4" half shelves, 1-1/2" square posts include eight each of 1", 2", 3", 4", 5", 6" lengths, and 1 lb bag of kiln wash. Weighs 164 lb. Truck Shipment and FOB Factory. See page 648 for details.

NUMBER	EACH
AF30149-0283	\$892.00

B Paragon™ Dragon Front-Loading Kiln

Power-packed and feature-packed! Front loading protects back muscles while its 16,500 watts heat the 24"W x 24"D x 27"H interior to cone 10. Extra insulation saves energy while cooling slowly, giving glazes time for full development. The 4" thick walls, top, and door are made of 3" firebrick backed by 1" of ceramic fiber block insulation. The floor is 4-1/2" thick firebrick. Mercury relays power the elements; built-in NEC/UL-compliant high-ampage fuses protect the kiln and wiring. The door swings open wide on a heavy 3/4" steel rod with sealed bearings. Two spring-loaded latches press the door tightly closed. Black finish with stainless steel case optional. Two side peepholes. Specify voltage, 1 or 3 phase and whether the 24" tall stand (also available with casters for easy moving) is to be shipped separate from the Dragon or attached and shipped as one unit. Certified to UL & CSA Standard 499. Each kiln is configured and built to order. Therefore, kilns are not returnable. Truck Shipment and FOB Factory. See page 648 for details.

NUMBER	FIRES TO CONE TEMP	PHASE	VOLTS	AMPS	DIA	HEIGHT	EACH
AF30151-2401	10 2350°F	1	240V	69	24"	27"	\$7153.00
AF30151-2081	10 2350°F	1	208V	79	24"	27"	7151.00
AF30151-2403	10 2350°F	3	240V	39.4	24"	27"	7153.00
AF30151-2083	10 2350°F	3	208V	52	24"	27"	7153.00

Dragon Stand with Casters (Sold Separately) — Put your kiln on wheels for easy portability. 24"H steel stand supports four pneumatic casters. Truck Shipment and FOB Factory. See page 648 for details.

NUMBER	EACH
AF30151-2050	\$1008.00

Dragon Stand Without Casters — Truck Shipment and FOB Factory. See page 648 for details.

NUMBER	EACH
AF30151-1024	\$670.00

Door Element — Elements in the side and back wall of the Dragon are standard; elements in the door are available as an option, installed at purchase. FOB Factory. See page 648 for details.

NUMBER	EACH
AF30151-1010	\$611.00

Furniture Kit — Kit contains one 22" shelf, four 22-1/2" shelves, 11, 1-1/2"W square posts (eight in each size 4", 6", and 8" lengths), and a 1 lb bag of Kiln Wash. Weighs 130 lb. Truck Shipment and FOB Factory. See page 648 for details.

NUMBER	EACH
AF30151-1020	\$781.00



Skutt® FireBox 8x6 LT Kiln

The perfect starter kiln! Fire ceramics, glass, metal clay — this compact kiln does it all. Easy and safe, it uses standard 120V voltage, and includes a shelf kit, kiln wash, and an instructional DVD. It incorporates preset programs for firing ceramics or glass. Or you can create custom programs to anneal or temper, fire precious metal clay or silver and gold jewelry, fuse and slump glass pieces, and more. The firing chamber measures 8" x 8" x 6". Fires to Cone 6. FOB Factory. See page 648 for details.

NUMBER	EACH
AF30282-1001	\$948.00



Skutt® Pyrometer

Accurate, wall-mounted, and easy-to-install, the Skutt Pyrometer helps determine progress during firing so you can plan the proper shut-off time. It operates from 0–2500°F and includes a heavy 8-gauge thermocouple and a 6 ft wire.

NUMBER	EACH
A30313-0000	\$189.99

Amaco® Kiln Cement

For sealing cracks and chips in kiln wall, floors, door, and other fire brick pieces. Mix with water for a smooth, plastic consistency. Mix with coarse grog or fragments of refractory for repairing large holes.

1lb Moist	EACH	6/EA
NUMBER		
A32923-0001	\$13.76	\$12.38

Amaco® Kiln Shelf Wash

Kiln Shelf Wash is used to coat and protect shelves during firing. With a 1/16" thick coating, shelf life is prolonged and glaze drippings are easy to remove.

NUMBER	SIZE	EACH	6/EA
A32922-0001	1 lb, Jar	\$7.65	\$6.89
A32922-0000	4 lb, Bag	22.50	20.25
A32922-1040	40 lb, Bag	69.95	62.95



C Vent-A-Kiln™ System

For any round kiln. It vents unhealthy, toxic, and unpleasant odors from ceramic kilns. It also eliminates heat buildup and it's easily portable. Spun aluminum hood fits on top of closed or propped vented kiln. Fan motor (115V), 2-speed control, counterweight pulley system, 10 ft of 5" hose, all clamps, and external mounting plate. The 44" system requires truck shipment. FOB Factory. See page 648 for details.

NUMBER	HOOD	KILN DIAMETER	EACH
AF30113-1027	27"	up to 19"-23"	\$525.00
AF30113-1032	32"	up to 24"-28"	545.00
AF30113-1037	37"	up to 29"-33"	568.00
AF30113-1044	44"	up to 34"-40"	750.00

Optional Swinging Wall Bracket Assembly FOB Factory. See page 648 for details.

NUMBER	BRACKET FOR	EACH
AF30113-0000	22", 27", 32", 37" Hoods	\$122.99
AF30113-1144	44" Hood	156.50

D Kiln Safety Screen

Protect your hot or hazardous areas with this safety screen. Its three 2 ft x 3 ft panels are made with sturdy aluminum frames and fire-resistant curtains. To cover areas larger than 6 ft wide, extra panels can be purchased and added onto the frame. When not in use the safety screen can be folded to a compact 2 ft x 3 ft size. Screen colors are assorted. You may receive either a Beige or Hunter Green color. FOB Factory. See page 648 for details.

NUMBER	EACH
AF30201-1003	\$169.99

Extra Single Panel FOB Factory. See page 648 for details.

NUMBER	EACH
AF30201-0000	\$58.99

Amaco® Kiln Shelves

NUMBER	SIZE	MODEL	STYLE	CONE	EACH
A30130-1010	26" x 13" x 5/8"	EX-399, EX-1099	Half Octagon	6	\$81.28
A30130-1011	21" x 10-1/2" x 3/4"	EX-270, EX-247	Half Round	10	49.43
A30130-1012	19" x 9-1/2" x 5/8"	EX-344, EX-365	Half Round	10	40.64

for more kiln shelf shapes and sizes
visit DickBlick.com



E Orton™ Universal Vent Master Kit

Remove fumes released from any size kiln with the Orton Universal Vent Master. It can be floor or wall mounted with blower installation possible. There's no vibration transferred from blower to kiln for efficient removal of kiln gases due to Orton's patented downdraft technology. For product details, visit DickBlick.com.

NUMBER	DESCRIPTION	EACH
A30170-0110	Vent Kit, 110V	\$507.00
A30170-0240	Vent Kit, 240V	525.00
A30170-1009	Expansion Kit	181.77
A30170-1109	Extender Kit	40.73

F Brent® Kiln Shelf Cart

Load and unload kiln furniture easily and efficiently with this rolling cart. Steel rods store up to 16 shelves (up to 20") vertically, separating them to reduce damage. Three shelves (included) provide room for kiln posts, cones, stilts, and more and are interchangeable with Amaco/Brent Warecart. Heavy-duty casters. 47-3/4"H x 14-1/2"W x 36"L. Weighs 65 lb. FOB Factory. See page 648 for details.

NUMBER	EACH
AF30242-1001	\$715.00





Orton™ Self-Supporting Cones

No cone holders needed. Use for visual firings, to test kiln uniformity, and to check shut-off devices. Box of 25.

NUMBER	CONE	TEMP	EACH	6/EA
A32920-1006	06	1834°F	\$9.99	\$8.99
A32920-1005	05	1918°F	9.99	8.99
A32920-1004	04	1944°F	9.99	8.99
A32920-9005	5	2167°F	9.99	8.99
A32920-9006	6	2232°F	9.99	8.99
A32920-9010	10	2345°F	9.99	8.99



Orton™ Pyrometric Mini Bars

The uniform shape (1"L x 1/8"Sqr) of these bars makes consistent placement easy without affecting the firing. Easy to use; just position one bar flat-side-down in your kiln sifter. It should be deformed to a 90° angle after firing. Box of 50 bars.

NUMBER	CONE	TEMP	EACH	3/EA
A32919-1150	06	1834°F	\$12.90	\$11.61
A32919-1050	05	1918°F	12.90	11.61
A32919-1250	04	1944°F	12.90	11.61
A32919-1350	5	2167°F	12.90	11.61
A32919-1450	6	2232°F	12.90	11.61



Orton™ Small "Junior" Pyrometric Cones

Unlike a pyrometer, which tells you only the atmospheric temperature in your kiln, one pyrometric cone in your kiln sifter will shut off the power when the exact heat absorption temperature of the ware is reached. Box of 50.

NUMBER	CONE	TEMP	EACH	10/EA
A32921-1150	018	1391°F	\$10.65	\$9.59
A32921-1016	016	1422°F	10.65	9.59
A32921-1006	06	1873°F	10.65	9.59
A32921-1005	05	1944°F	10.65	9.59
A32921-1003	03	1987°F	10.65	9.59
A32921-1004	4	2008°F	10.65	9.59
A32921-1040	4	2208°F	10.65	9.59
A32921-1050	5	2230°F	10.65	9.59
A32921-1070	7	2262°F	10.65	9.59
A32921-1060	6	2291°F	10.65	9.59
A32921-1010	10	2426°F	10.65	9.59



Kemper® Element Pins

Used to hold loose kiln elements in place, these pins have sharp ends for easy insertion in the kiln wall. Made of a heat-resistant alloy for temperatures to 2500°F (Cone 13). Package of 12.

NUMBER	EACH	6/EA
A32930-1012	\$4.85	\$4.37

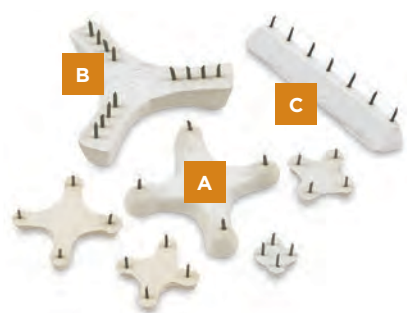

A-C Steel-Pointed Stilts

High-quality steel-pointed stilts come in a variety of shapes.

A Star Stilts — Package of 12.

NUMBER	SIZE	GAP	EACH
A32918-1009	9	1/4"	\$10.05
A32918-1010	10	3/4"	10.32
A32918-1011	11	1"	10.98
A32918-1012	12	1-1/2"	12.17
A32918-1013	13	2"	14.55

B 12-Point Stilts — 5/8"H x 2-1/2"W. Package of 12.

NUMBER	EACH
A32918-1109	\$23.42

C 7-Point Bar Stilts — 3-1/4"L x 1/2"H. Package of 12.

NUMBER	EACH
A32918-1112	\$23.02

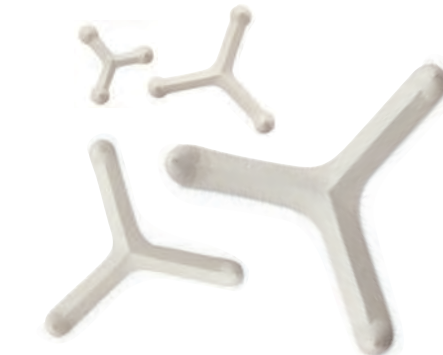

Amaco® Stilt Kits

Prevent glazed objects from touching kiln shelves with Amaco Stilt Kits. The dimensions between the points are listed behind the stilt number. Cone 10 (2381°F, 1305°C) maximum. Package of 12.

NUMBER	SIZE	EACH
A32924-0200	1-1/8"	\$48.95
A32924-0300	1-1/2"	49.99
A32924-0400	1-3/4"	52.07
A32924-0500	2"	54.15
A32924-0600	2-1/4"	56.23
A32924-0700	2-1/2"	58.32
A32924-0800	2-3/4"	62.83
A32924-0900	3"	68.34
A32924-1000	3-1/2"	77.16
A32924-1100	3-3/4"	82.67
A32924-1200	4-1/2"	87.08



Orton™ Vertical Tile Setter

Helps economize on kiln space when firing tiles. 7" long with seven slots. Stackable. For use up to Cone 06 (1830°F). Sold as a pair.

NUMBER	EACH	3/EA
A32914-1007	\$22.60	\$20.34



Star Bead Tree

Fire macramé beads and other hanging objects with this versatile, space-saving tool that has two durable stoneware supports with 6" long wires. Seven heavy-gauge wires can be staggered as needed to accommodate any size object. Not to be used for raku firing. 3-1/2"W x 6-3/4"H. Each wire is 10-1/8" long.

NUMBER	EACH	6/EA
A32900-1006	\$38.57	\$34.72



Amaco® Shelf Supports

These shelf supports are strong, durable, and maximize the firing capacity of your kiln. For temperatures up to Cone 14.

NUMBER	SIZE	EACH	12/EA
A30129-1300	1" x 1" x 4"	\$2.76	\$2.48
A30129-1400	1" x 1" x 6"	4.23	3.79
A30129-1111	1-5/8" x 1-5/8" x 1"	2.10	1.89
A30129-1121	1-5/8" x 1-5/8" x 2"	2.44	2.20
A30129-1131	1-5/8" x 1-5/8" x 3"	2.60	2.35
A30129-1141	1-5/8" x 1-5/8" x 4"	3.35	3.05
A30129-1151	1-5/8" x 1-5/8" x 5"	3.41	3.07
A30129-1161	1-5/8" x 1-5/8" x 6"	4.23	3.79
A30129-1171	1-5/8" x 1-5/8" x 7"	4.41	3.97
A30129-1181	1-5/8" x 1-5/8" x 8"	4.51	4.06



Amaco® Plate Setter

Save kiln space and classroom time — these sturdy Plate Setters allow up to six plates to be fired by stacking them. Sturdy and easy to use, each set of three fires one plate. Additional sets interlock on top of the bottom one. Cone 6 maximum firing.

NUMBER	EACH	6/EA
A32917-0039	\$15.49	\$13.94

Mayco® Clay Carbon Transfer Paper

Use this specially treated paper to transfer designs or patterns to ceramic greenware or dried surfaces that have been glazed or underglazed. Pack contains 12, 8-1/2" x 11" reusable sheets.

NUMBER	EACH	12/EA
A32739-1000	\$4.63	\$4.17



MAYCO®

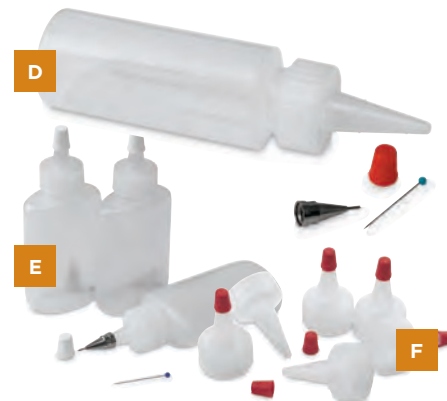

D-F Mayco® Decorating Accessories

Perfect for all types of detailing, fine lines, writing, and outlining, these decorating accessories can be used with glazes or underglazes.

D Writer Tip Kit — Includes a 2 oz squeeze bottle, a metal writer tip, a plastic detailer tip, and a cap.

NUMBER	EACH	6/EA
A30706-1009	\$4.35	\$3.92

E Designer Bottle with Writer Tip — Includes three bottles with metal writer tips and pins.

NUMBER	EACH	6/EA
A30706-1039	\$7.26	\$6.53

F Detailer Cap — This set of six threaded plastic caps with detailer tips can be fitted to 2 oz, 8 oz, and 16 oz squeeze bottles.

NUMBER	EACH	6/EA
A30706-1069	\$4.91	\$4.42



Royal & Langnickel® Ceramic Classroom Brush Assortment

An ideal selection of brushes for working with ceramics and glazes, this 72-piece assortment includes a variety of hair types, profiles, and sizes: 12 Size 8 Goat Hair Fan, 12 Size 3/4" Bristle Glaze, 24 Sable Rounds (Sizes 1 and 5), 12 Sable Round Liners (Size 10), and 12 Sable Shaders (Size 10).

NUMBER	EACH	3/EA
A06424-1729	\$172.99	\$159.40



Blick® Ceramic Glaze Detail 7-Brush Set

Includes six Blick Scholastic brushes: Sable Round Size 0 and 4, Sable Fan Size 4, Fitch Bright Size 10, Camel Oval Wash 1", Black Bristle Extended Easel 1", and a Holbein bamboo brush Size 2.

NUMBER	EACH	12/EA
A05692-1009	\$19.65	\$17.68



Mayco® Designer Liners

Cone 06-6 (1828°F-2232°F)

This concentrated, clay-based black pigment is packaged in a 1.25 oz squeeze bottle with a metal writer tip. Use it on clay, bisque, or over other glazes. Fires to a matte finish. Colors can be assorted for quantity pricing.

NUMBER	COLOR	EACH	12/EA
A30488-2013	Black	\$5.03	\$4.53
A30488-5003	Blue	5.03	4.53
A30488-5483	Bright Blue	5.03	4.53
A30488-7253	Bright Green	5.03	4.53
A30488-8003	Brown	5.03	4.53
A30488-7263	Green	5.03	4.53
A30488-4513	Orange	5.03	4.53
A30488-3003	Red	5.03	4.53
A30488-1003	White	5.03	4.53
A30488-4023	Yellow	5.03	4.53



Pack of 6 — One each Black, Blue, Bright Green, Brown, Red, and White.

NUMBER	EACH	12/EA
A30488-1009	\$25.95	\$23.35



Royal & Langnickel® Aqualon Synthetic Goat Fan Brushes

Soft fan brushes made from durable, multi-diameter synthetic fibers, perfect for covering large surfaces with ceramic glazes, underglazes, and fluid colors. Fibers are soft enough to lay colors down like natural hair, but will not shed. Short acrylic handles won't absorb moisture even when left in water, glaze, or paint so there's no swelling or chipping.

NUMBER	SIZE	WIDTH	LENGTH	EACH
A04316-1006	6	1-49/64"	1-3/16"	\$5.50
A04316-1008	8	2-11/64"	1-3/8"	6.99
A04316-1010	10	2-9/16"	1-37/64"	7.99
A04316-1012	12	3-35/64"	1-49/64"	8.99

NEW! QUICK QUOTE.
Create a quote on demand at
DickBlick.com

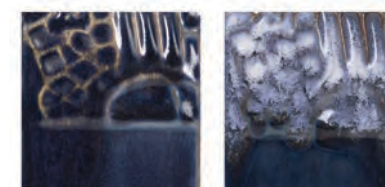

Clear White

Mayco® Pottery Cascade Glazes

Perfect for the low-fire ceramicist seeking to create looks achieved at higher temperatures. Moving, flowing glazes that are commonly used over other glazes to create reactions and movement. Can also be used as a flux with Mayco Elements Glazes to create movement in the colors. Great visual effects can be created when added under, over, or between Elements glazes.

NUMBER	COLOR	EACH	12/EA
A30442-1606	Clear	\$18.50	\$16.65
A30442-1026	White	18.50	16.65

See Page 535 for
Mayco® Elements Glazes.



Xiem™ Studio Precision Applicators

A true innovation for glazing, slip-trailing, detailing, writing, applying wax resist, painting, and just about any other liquid decorating technique! The system consists of a super-soft rubber applicator bulb, a nickel-plated connector, and four interchangeable tips. It's lightweight, easy to use and clean, and the precision tip/connector system ensures that air pressure is evenly and effortlessly regulated.

NUMBER	DESCRIPTION	EACH	6/EA
A36967-1001	1 oz Bulb	\$20.89	\$18.80
A36967-1003	3 oz Bulb	21.99	19.79



Amaco® LEAD-FREE Semi-Moist Underglaze Sets

Fire to temperature of covering glaze.

Fine art decorating colors in watercolor pans for intricate, fine detail on figurines, dinnerware, and more. Intermix for tints and shading. Works best with Clear Transparent Glazes (see page 524) at Cone 05.



Set No. 108 — Maroon, Light Yellow, Blue-Green, Dark Blue, Black, Dark Green, Light Brown, and White.

NUMBER	EACH	12/EA
A30415-1088	\$37.99	\$34.19



Set No. 109 — Turquoise, Lilac, Medium Blue, Pink, Warm Gray, Mahogany Brown, Bright Yellow, and Warm Green.

NUMBER	EACH	12/EA
A30415-1099	\$37.99	\$34.19



Set No. 110 — Purple, Light Blue, Aqua, Rose, Orange, Peach, Chartreuse, and Sun Tan.

NUMBER	EACH	12/EA
A30415-1009	\$37.99	\$34.19



Set No. 111 — Electric Blue, Amethyst, Violet, Red, Light Red, Salmon, Real Orange, and Hunter Green.

NUMBER	EACH	12/EA
A30415-1019	\$37.99	\$34.19



Amaco® LEAD-FREE Underglaze Decorating Pencils

Reformulated to be more intense. Ideal for shading, fine line drawing, or identification. Maximum firing temperature is Cone 10 for Blue, Black, and Green, Cone 5 for Brown and Yellow, and Cone 05 for Rose. Lead-free. Colors can be assorted for quantity pricing.

NUMBER	COLOR	EACH	12/EA
A30438-2020	Black	\$14.89	\$13.40
A30438-5000	Blue	14.89	13.40
A30438-8000	Brown	14.89	13.40
A30438-7000	Green	14.89	13.40
A30438-3170	Rose	14.89	13.40
A30438-4000	Yellow	14.89	13.40
A30438-0069	Set of 6	98.27	88.44



Amaco® LEAD-FREE Underglaze Crayons

For pastel techniques. Sketching on bisque results in a pebbled appearance. Blend by rubbing with fingers. Obtain watercolor effects by brushing sketches with water. 2-3/4" x 7/16" crayons. Works best with Clear Transparent Glazes (see page 524) at Cone 05.

Set No. 1 — Includes eight colors in a plastic hinged box: Turquoise, Yellow, Rose, Dark Blue, Brown, Dark Green, Black, and White.

NUMBER	EACH	12/EA
A30423-1009	\$40.05	\$36.05

Set No. 2 — Includes eight colors in a plastic hinged box: Lilac, Yellow-Green, Gray, Medium Green, Light Brown, Blue-Green, Dark Brown, and Medium Blue.

NUMBER	EACH	12/EA
A30423-0009	\$40.05	\$36.05



Amaco® LEAD-FREE Dipping Glazes

Lead-free, non-toxic glazes specially formulated for dipping Cone 04 bisque fired pieces. The glaze stops running as soon as the piece is lifted out of the glaze bucket, providing uniform application. Quick-drying. Food-safe when applied and fired to the recommended temperature on the label.

DC-10 Clear Dipping Glaze — Ideal for use with all Amaco decorating colors. Glaze fire to Cone 05 (1911°F). Gallon.

NUMBER	EACH	12/EA
A30432-0009	\$58.96	\$53.06

DW-11 White Dipping Glaze — For producing Majolica pieces at Cone 05. Gallon.

NUMBER	EACH	12/EA
A30451-1001	\$51.31	\$46.19



Kemper® Dipping Tongs

Designed to help achieve a flawless look, Kemper Dipping Tongs have four sharp gripping points for minimal contact. The plated steel tongs have dipped plastic handles for a firm hold on ceramics pieces of various sizes and shapes.

NUMBER	EACH
A30346-1000	\$12.05



Amaco® Wax Resist

This wax emulsion, applied on greenware or bisque as a method of decoration, "resists" application of glaze, slip, and underglaze.

NUMBER	SIZE	EACH	12/EA
A32936-0006	Pint (473 ml)	\$18.52	\$16.66
A32961-1009	Gallon (3.78 Liter) Jar	83.36	75.03

Amaco® Gum Solution

Mix with water and add to thick glazes to improve brushability. Gum Solution slows drying time to prevent cracking, or can be used to bring old, thick glazes back to their original creamy consistency. It can also be used as a binding medium for dry enameling powders, or mixed with enameling powder for wet application.

NUMBER	DESCRIPTION	EACH	12/EA
A30439-1006	Pint (473 ml) Jar	\$8.28	\$7.46

HEALTH & SAFETY ICONS: ●=CL / ■=Prop 65 / ▼=CL & Prop 65 See page 644 for more information.

AMACO®

Amaco® LEAD-FREE Velvet Underglazes

Cone 06-10

Extremely versatile to use. Can be applied to leather hard clay, greenware, or bisque. Velvets are true to color and won't flow during firing, so they are great for detailed work. Cover with Amaco LG-10 Transparent Gloss Glaze to intensify color, create a smooth gloss surface, and make food safe. (Chips shown are Cone 05; for Cone 5 and 10 results, visit DickBlick.com.) Colors can be assorted for quantity pricing.

NUMBER	COLOR	EACH	12/EA
A30411-1536	V-301 Ivory Beige	\$22.99	\$20.69
A30411-8176	V-303 Terra Cotta	22.99	20.69
A30411-4116	V-304 Straw	22.99	20.69
A30411-4006	V-308 Yellow	22.99	20.69
A30411-4426	V-309 Deep Yellow	22.99	20.69
A30411-8226	V-313 Red Brown	22.99	20.69
A30411-8106	V-314 Chocolate Brown	22.99	20.69
A30411-3356	V-315 Peach	23.30	20.99
A30411-3716	V-316 Light Pink	23.30	20.99
A30411-8916	V-318 Rose	23.30	20.99
A30411-6046	V-320 Lavender	34.25	30.83
A30411-6036	V-321 Lilac	23.30	20.99
A30411-6006	V-322 Purple	23.30	20.99
A30411-3516	V-323 Salmon	23.30	20.99
A30411-5356	V-325 Baby Blue	22.99	20.69
A30411-5026	V-326 Medium Blue	22.99	20.69
A30411-5106	V-327 Turquoise Blue	22.99	20.69
A30411-5856	V-328 Iceberg Blue	23.30	20.99
A30411-5086	V-332 Teal Blue	22.99	20.69
A30411-7466	V-333 Avocado	22.99	20.69
A30411-5056	V-336 Royal Blue	50.59	45.55
A30411-5826	V-341 Blue Green	23.30	20.99
A30411-7636	V-343 Chartreuse	22.99	20.69
A30411-7016	V-345 Light Green	22.99	20.69
A30411-4506	V-350 Orange	22.99	20.69
A30411-7036	V-353 Dark Green	22.99	20.69
A30411-7156	V-354 Leaf Green	22.99	20.69
A30411-2546	V-356 Pearl Gray	23.30	20.99
A30411-1766	V359 Ultra White	34.25	30.83
A30411-1016	V-360 White	22.99	20.69
A30411-2046	V-361 Jet Black	22.99	20.69
A30411-2906	V364 Elephant	50.59	45.55
A30411-8006	V-366 Teddy Bear Brown	22.99	20.69
A30411-2266	V-370 Velour Black	34.25	30.83
A30411-7516	V-372 Mint Green	22.99	20.69
A30411-3346	V-375 Maroon	50.59	45.55
A30411-7506	V-376 Hunter Green	22.99	20.69
A30411-6516	V-380 Violet	50.59	45.55
A30411-7456	V-381 Amethyst	50.59	45.55
A30411-3026	V-382 Red	50.59	45.55
A30411-3016	V-383 Light Red	50.59	45.55
A30411-4636	V-384 Real Orange	50.59	45.55
A30411-9356	V-385 Cinnamon	22.99	20.69
A30411-5816	V-386 Electric Blue	22.99	20.69
A30411-3076	V-387 Bright Red	50.59	45.55
A30411-3746	V-388 Radiant Red	50.59	45.55
A30411-4616	V-389 Flame Orange	50.59	45.55
A30411-4596	V-390 Bright Orange	50.59	45.55
A30411-4776	V-391 Intense Yellow	50.59	45.55

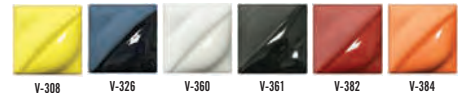

Class Pack — 6 Pints (473 ml).

NUMBER	EACH
A30411-0069	\$185.79



Class Pack — 12 Pints (473 ml).

NUMBER	EACH
A30411-0129	\$390.00

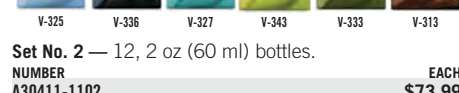

Set No. 2 — 12, 2 oz (60 ml) bottles.

NUMBER	EACH
A30411-1102	\$73.99



Set No. 1 — 12, 2 oz (60 ml) bottles.

NUMBER	EACH
A30411-1101	\$73.99



Set No. 3 — 12, 2 oz (60 ml) bottles.

NUMBER	EACH
A30411-1103	\$73.99



Set No. 4 — 12, 2 oz (60 ml) bottles.

NUMBER	EACH
A30411-1104	\$73.99



Set No. 5 — 12, 2 oz (60 ml) bottles.

NUMBER	EACH
A30411-1105	\$73.99



Set No. 6 — 12, 2 oz (60 ml) bottles.

NUMBER	EACH
A30411-1106	\$73.99



Set No. 7 — 12, 2 oz (60 ml) bottles.

NUMBER	EACH
A30411-1107	\$73.99

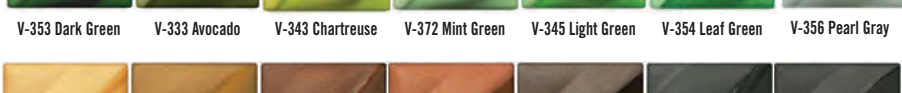

Set No. 8 — 12, 2 oz (60 ml) bottles.

NUMBER	EACH
A30411-1108	\$73.99

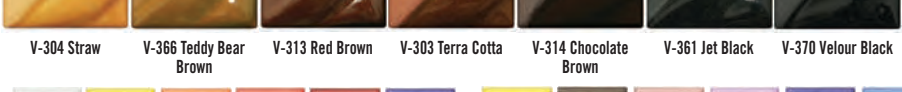

Set No. 9 — 12, 2 oz (60 ml) bottles.

NUMBER	EACH
A30411-1109	\$73.99



Set No. 10 — 12, 2 oz (60 ml) bottles.

NUMBER	EACH
A30411-1110	\$73.99

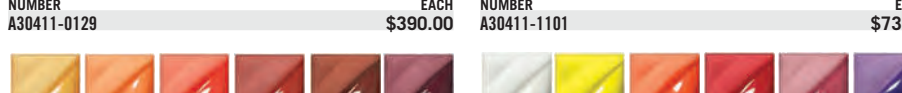

Set No. 11 — 12, 2 oz (60 ml) bottles.

NUMBER	EACH
A30411-1111	\$73.99



Set No. 12 — 12, 2 oz (60 ml) bottles.

NUMBER	EACH
A30411-1112	\$73.99

WARNING! Products marked with a Prop 65 symbol (■ or ▼) can expose you to chemicals, including cadmium, which are known to the State of California to cause cancer and birth defects or other reproductive harm. For more information, visit P65Warnings.ca.gov.

AMACO



Amaco LEAD-FREE LUG Underglazes

Cone 06-10 (1855°-2381°F) LEAD-FREE



Brilliant, ready-to-use colors for covering large areas. Good for detailed painting, sgraffito, watercolor effects, free brush, wax resist, and mishima decoration. These opaque colors may be applied to greenware or bisque. Finish with a clear glaze or experiment with colored glazes for a deeper effect. All are sprayable and food safe when applied under Amaco LG-10 Clear glaze.

Colors can be assorted for quantity pricing.

COLOR	PINT (473 ML)	EACH	12/EA	2 OZ (59 ML)	EACH	12/EA
LUG-1 Black	A30417-2006	\$27.65	\$24.89	A30417-2004	\$8.38	\$7.55
LUG-10 White	A30417-1006	27.65	24.89	A30417-1004	8.38	7.55
LUG-15 Warm Gray	A30417-2306	27.65	24.89	A30417-2614	8.38	7.55
LUG-20 Light Blue	A30417-5016	27.65	24.89	A30417-5014	8.38	7.55
LUG-21 Medium Blue	A30417-5026	27.65	24.89	A30417-5024	8.38	7.55
LUG-22 Dark Blue	A30417-5036	27.65	24.89	A30417-5032	8.38	7.55
LUG-25 Turquoise	A30417-5116	27.65	24.89	A30417-5112	8.38	7.55
LUG-26 Aqua	A30417-5156	27.65	24.89	A30417-5152	8.38	7.55
LUG-30 Light Brown	A30417-8016	27.65	24.89	A30417-8014	8.38	7.55
LUG-31 Mahogany Brown	A30417-8446	27.65	24.89	A30417-8444	8.38	7.55
LUG-40 Chartreuse	A30417-7636	27.65	24.89	A30417-4314	8.38	7.55
LUG-41 Warm Green	A30417-7736	27.65	24.89	A30417-7734	8.38	7.55
LUG-42 Blue Green	A30417-5106	27.65	24.89	A30417-7914	8.38	7.55
LUG-43 Dark Green	A30417-7036	27.65	24.89	A30417-7034	8.38	7.55
LUG-50 Pink	A30417-3056	27.65	24.89	A30417-3054	8.38	7.55
LUG-51 Rose	A30417-3176	27.65	24.89	A30417-3174	8.38	7.55
LUG-52 Peach	A30417-4106	27.65	24.89	—	—	—
LUG-53 Sun Tan	A30417-8496	27.65	24.89	—	—	—
LUG-54 Lilac	A30417-6036	27.65	24.89	A30417-6032	8.38	7.55
LUG-55 Purple	A30417-6006	27.65	24.89	A30417-6004	8.38	7.55
LUG-56 Maroon	A30417-3346	27.65	24.89	—	—	—
LUG-58 Dark Red	A30417-3036	27.65	24.89	A30417-3034	8.38	7.55
LUG-60 Light Yellow	A30417-4016	27.65	24.89	—	—	—
LUG-61 Bright Yellow	A30417-4296	27.65	24.89	A30417-4294	8.38	7.55
LUG-65 Orange	A30417-4506	27.65	24.89	A30417-4504	8.38	7.55

Liquid Underglaze Class Packs and Sets



Class Pack of 6 — Includes six 16 oz jars. For set colors, visit DickBlick.com.

NUMBER A30417-0069 EACH \$169.99



Set No. 712 — Includes 12, 2 oz jars. For set colors, visit DickBlick.com.

NUMBER A30417-0712 EACH \$90.49



Class Pack of 12 — Includes 12, 16 oz jars. For set colors, visit DickBlick.com.

NUMBER A30417-0129 EACH \$350.00



Set No. 812 — Includes 12, 2 oz jars. For set colors, visit DickBlick.com.

NUMBER A30417-0812 EACH \$90.49



Amaco LEAD-FREE Clear Transparent Glaze

No. 10 LG-10 Clear Transparent Glaze — Lead-free liquid covering glaze for applying on decorated greenware or bisque. Will not discolor the underglaze decoration or cause colors to bleed. Produces a smooth, high-gloss surface. Cone 05.

NUMBER	SIZE	EACH	12/EA
A30413-1026	Pint (473 ml)	\$17.99	\$16.19
A30413-1029	Gallons (3.78 liter)	68.35	61.50

No. F-10 Clear Transparent Glaze — Lead-free, safe for dinnerware. Apply to mature fired bisque. Cone 05.

NUMBER	SIZE	EACH	24/EA
A30406-1026	Pint (473 ml)	\$17.40	\$15.65
A30406-1009	Gallon (3.78 liter)	68.35	61.50

Amaco LEAD-FREE Transparent Matte Glaze

Gives a soft matte finish when applied over a glaze color. Apply to mature Cone 05 bisque. Slow firing is recommended.

NUMBER	COLOR	SIZE	EACH	12/EA
A30419-1736	LM-10 Translucent Matte	Pint (473 ml)	\$19.55	\$17.60

Mayco LEAD-FREE Stroke & Coat Clear Glazes

NUMBER	SIZE	EACH	12/EA
A30408-1026	Pint (473 ml)	\$9.33	\$8.40
A30408-1029	Gallon (3.78 liter)	34.15	30.75

NUMBER	SIZE	EACH	6/EA
A30408-1000	1 Gallon (3.78 liter)	\$34.15	\$30.75
A30408-1005	3 Gallon (11.35 liter)	79.35	71.40

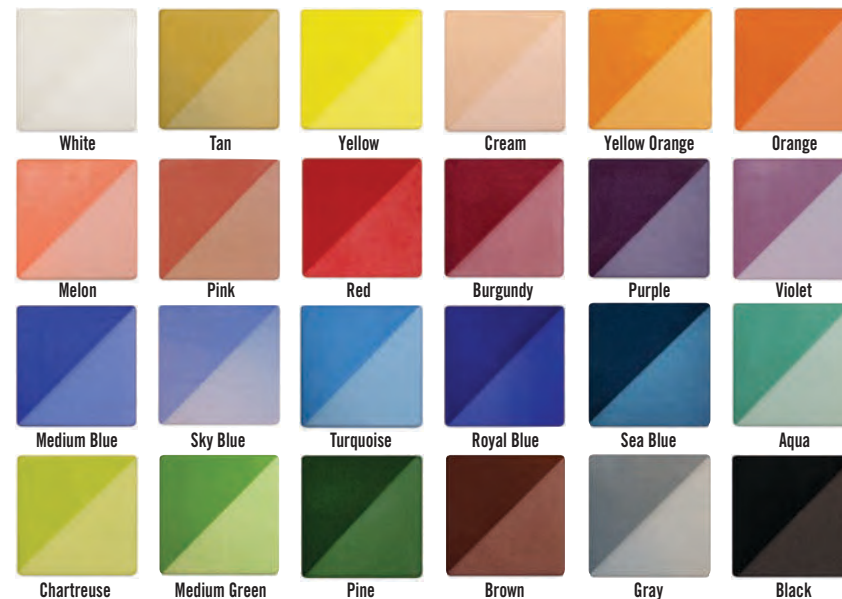

Set of 6 Pints — Includes White, Yellow, Royal Blue, Black, Orange, and Red.



Set of 12 Pints — Includes White, Yellow, Pink, Royal Blue, Sky Blue, Medium Green, Brown, Black, Gray, Orange, Red, and Purple.

NUMBER	EACH
A30457-1069	\$118.82

Set of 12 Pints — Includes White, Yellow, Pink, Royal Blue, Sky Blue, Medium Green, Brown, Black, Gray, Orange, Red, and Purple.



NUMBER	EACH
A30457-1129	\$212.28

Mayco Fundamentals Underglazes

Cone 06-10 (1830°F-2381°F)

These underglazes are as consistent and versatile as any on the market. Choose from a variety of vibrant colors, and apply to wet clay, greenware, or bisque. Use for designs or solid coverage — or for sgraffito, majolica, spatter, or burnishing techniques. Colors are intermixable. Apply with a brush or sponge. Do not spray apply. Non-toxic and food safe when a clear glaze is applied over them. For additional usage details, visit DickBlick.com. Colors can be assorted for quantity pricing.

NUMBER	COLOR	EACH	12/EA
A30569-7176	Apple Green	\$19.12	\$17.21
A30569-3726	Blush	19.12	17.21
A30569-5486	Bright Blue	19.12	17.21
A30569-4296	Bright Yellow	19.12	17.21
A30569-2996	Cement	19.12	17.21
A30569-8286	Chestnut Brown	19.12	17.21
A30569-1036	China White	19.12	17.21
A30569-8106	Chocolate	19.12	17.21
A30569-8366	Cocoa	19.12	17.21
A30569-2546	Dark Gray	19.12	17.21
A30569-3716	Dragon Red	19.12	17.21
A30569-3736	Fire Engine Red	19.12	17.21
A30569-4306	Flame Red	19.12	17.21
A30569-7276	Forest Green	19.12	17.21
A30569-7256	Jade	19.12	17.21
A30569-2046	Jet Black	19.12	17.21
A30569-5926	Kings Blue	19.12	17.21
A30569-7156	Leaf Green	19.12	17.21
A30569-6036	Lilac	19.12	17.21
A30569-5556	Marine Blue	19.12	17.21
A30569-4516	Orange	19.12	17.21
A30569-4556	Orange Sorbet	19.12	17.21
A30569-6166	Pansy Purple	19.12	17.21
A30569-7376	Pear Green	19.12	17.21
A30569-5726	Regal Purple	19.12	17.21
A30569-5166	Sea Blue	19.12	17.21
A30569-2626	Silver Gray	19.12	17.21
A30569-8506	Spice Brown	19.12	17.21
A30569-7336	Spring Green	19.12	17.21
A30569-4276	Squash Yellow	19.12	17.21
A30569-5156	Tucson Turquoise	19.12	17.21



NUMBER	EACH	3/EA
A30569-1001	\$198.42	\$178.60

SPEEDBALL

Speedball Ceramic Underglazes



Cone 06-10 (1855°-2381°F)

Bright, intense colors that are highly saturated for spectacular results, these underglazes are compatible with Speedball Earthenware Glazes, and can be used for a variety of decorating techniques. They may be applied to greenware or bisque and can be blended. The liquid, opaque colors will not move or bleed, making them perfect for detailed painting, design work, and sgraffito. Because they're lead-free and clean up easily with water, they're ideal for classroom use. These underglazes are dinnerware safe when used and fired as directed. However, tableware producers should have finished ware lab tested to determine dinnerware suitability due to firing variances and contamination. Colors can be assorted for quantity pricing.

NUMBER	COLOR	EACH	12/EA
A30457-5166	Aqua	\$12.44	\$11.24
A30457-2026	Black	17.42	15.68
A30457-8006	Brown	12.44	11.24
A30457-3146	Burgundy	24.03	21.62
A30457-7636	Chartreuse	12.44	11.24
A30457-1106	Cream	12.44	11.24
A30457-2506	Gray	12.44	11.24
A30457-5026	Medium Blue	12.44	11.24
A30457-7026	Medium Green	14.83	13.34
A30457-7926	Melon	17.42	15.68
A30457-4516	Orange	24.03	21.62
A30457-7916	Pine	12.44	11.24
A30457-3066	Pink	14.83	13.34
A30457-6006	Purple	24.03	21.62
A30457-3016	Red	24.03	21.62
A30457-5056	Royal Blue	24.03	21.62
A30457-5156	Sea Blue	12.44	11.24
A30457-5076	Sky Blue	12.44	11.24
A30457-8236	Tan	12.44	11.24
A30457-5116	Turquoise	12.44	11.24
A30457-6516	Violet	24.03	21.62
A30457-1026	White	12.44	11.24
A30457-4016	Yellow	14.83	13.34
A30457-4286	Yellow Orange	17.42	15.68

Class Pack — Includes 12 pints, one each of Apple Green, Bright Blue, Bright Yellow, China White, Chocolate, Dragon Red, Fire Engine Red, Jet Black, Kings Blue, Leaf Green, Orange, and Regal Purple.

NUMBER	EACH	3/EA
A30569-1001	\$198.42	\$178.60

AMACO®



Amaco® LEAD-FREE LG Series Low Fire Gloss Glazes



America's best-selling school glaze. Brilliant translucent colors that flow during firing to highlight surface textures and correct most application defects. Formulated for brushing on bisque. Colors with CL icon are not sprayable. All colors except for LG-27 (Turquoise Crackle) are food safe. Colors can be assorted for quantity pricing.

NUMBER	COLOR	EACH	12/EA
A30413-2196	LG-1 True Black	\$19.50	\$17.55
A30413-2066	LG-2 Black Lustre	19.50	17.55
A30413-1026	LG-10 Clear Transparent	17.99	16.19
A30413-1076	LG-11 Opaque White	19.50	17.55
A30413-2616	LG-14 Gray	19.50	17.55
A30413-5026	LG-20 Medium Blue	19.50	17.55
A30413-5036	LG-21 Dark Blue	26.29	23.65
A30413-5326	LG-23 Robin's Egg	19.50	17.55
A30413-5016	LG-24 Light Blue	19.50	17.55
A30413-5266	LG-25 Turquoise Green	19.50	17.55
A30413-5116	LG-26 Turquoise	19.50	17.55
A30413-8106	LG-30 Chocolate Brown	19.50	17.55
A30413-8456	LG-32 Metallic Brown	19.50	17.55
A30413-3716	LG-34 Red Brown	26.29	23.65
A30413-8396	LG-36 Freckled Brown	26.29	23.65
A30413-7036	LG-40 Dark Green	19.50	17.55
A30413-7016	LG-42 Light Green	19.50	17.55
A30413-7076	LG-44 Olive Green	19.50	17.55
A30413-7056	LG-45 Emerald Green	19.50	17.55
A30413-7156	LG-46 Leaf Green	19.50	17.55
A30413-7496	LG-48 Chrome Green	19.50	17.55
A30413-3346	LG-50 Maroon	26.29	23.65
A30413-6036	LG-51 Lilac	26.29	23.65
A30413-3736	LG-52 Petal Pink	19.50	17.55
A30413-3596	LG-54 Mulberry Red	26.29	23.65
A30413-6006	LG-55 Purple	26.29	23.65
A30413-3776	LG-57 Intense Red	26.29	23.65
A30413-3746	LG-58 Brilliant Red	26.29	23.65
A30413-3756	LG-59 Hot Red	26.29	23.65
A30413-4036	LG-60 Dark Yellow	19.50	17.55
A30413-4266	LG-61 Canary Yellow	19.50	17.55
A30413-4016	LG-62 Light Yellow	19.50	17.55
A30413-4936	LG-63 Brilliant Yellow	19.50	17.55
A30413-8136	LG-65 Amber	26.29	23.65
A30413-4616	LG-67 Fire Orange	26.29	23.65
A30413-4946	LG-68 Vivid Orange	26.29	23.65
A30413-4666	LG-760 Pale Yellow	19.50	17.55

NUMBER	COLOR	EACH	12/EA
A30413-2199	LG-1 True Black	\$98.99	\$88.99
A30413-1029	LG-10 Clear Transparent	68.35	61.50
A30413-1079	LG-11 Opaque White	79.15	71.25
A30413-5039	LG-21 Dark Blue	118.50	106.70
A30413-7159	LG-46 Leaf Green	98.99	88.99
A30413-3749	LG-58 Brilliant Red	118.50	106.70
A30413-8139	LG-65 Amber	118.50	106.70

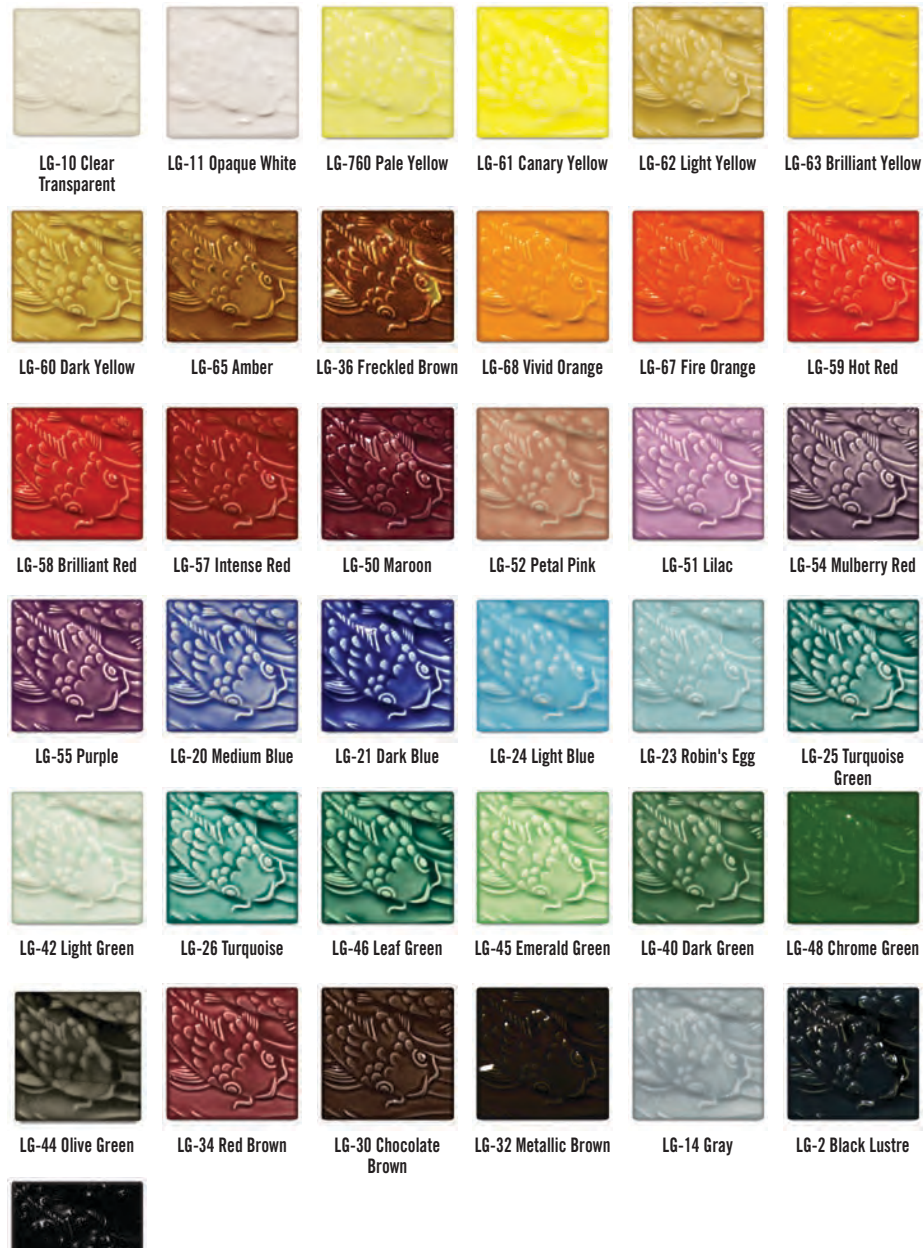

7-12 Class Pack 1 — 6 Pints (473 ml).	K-6 Class Pack 1 — 12 Pints (473 ml).																																																
<table border="1"> <tr><td>10</td><td>46</td><td>21</td><td>55</td><td>1</td><td>58</td></tr> <tr><td>10</td><td>46</td><td>21</td><td>55</td><td>1</td><td>58</td></tr> <tr><td>11</td><td>52</td><td>57</td><td>51</td><td>23</td><td>20</td></tr> <tr><td>45</td><td>26</td><td>48</td><td>30</td><td>65</td><td>2</td></tr> </table>	10	46	21	55	1	58	10	46	21	55	1	58	11	52	57	51	23	20	45	26	48	30	65	2	<table border="1"> <tr><td>10</td><td>61</td><td>68</td><td>59</td><td>55</td><td>24</td></tr> <tr><td>21</td><td>40</td><td>50</td><td>36</td><td>14</td><td>1</td></tr> <tr><td>10</td><td>67</td><td>58</td><td>55</td><td>24</td><td>63</td></tr> <tr><td>21</td><td>42</td><td>48</td><td>50</td><td>36</td><td>1</td></tr> </table>	10	61	68	59	55	24	21	40	50	36	14	1	10	67	58	55	24	63	21	42	48	50	36	1
10	46	21	55	1	58																																												
10	46	21	55	1	58																																												
11	52	57	51	23	20																																												
45	26	48	30	65	2																																												
10	61	68	59	55	24																																												
21	40	50	36	14	1																																												
10	67	58	55	24	63																																												
21	42	48	50	36	1																																												
<table border="1"> <tr><td>NUMBER</td><td>EACH</td></tr> <tr><td>A30413-0069</td><td>\$125.75</td></tr> </table>	NUMBER	EACH	A30413-0069	\$125.75	<table border="1"> <tr><td>NUMBER</td><td>EACH</td></tr> <tr><td>A30413-1129</td><td>\$285.99</td></tr> </table>	NUMBER	EACH	A30413-1129	\$285.99																																								
NUMBER	EACH																																																
A30413-0069	\$125.75																																																
NUMBER	EACH																																																
A30413-1129	\$285.99																																																
<table border="1"> <tr><td>NUMBER</td><td>EACH</td></tr> <tr><td>A30413-0129</td><td>\$255.99</td></tr> </table>	NUMBER	EACH	A30413-0129	\$255.99	<table border="1"> <tr><td>NUMBER</td><td>EACH</td></tr> <tr><td>A30450-0129</td><td>\$249.50</td></tr> </table>	NUMBER	EACH	A30450-0129	\$249.50																																								
NUMBER	EACH																																																
A30413-0129	\$255.99																																																
NUMBER	EACH																																																
A30450-0129	\$249.50																																																

HEALTH & SAFETY ICONS: ●=CL / ■=Prop 65 / ▼=CL & Prop 65
See page 644 for more information.

BLICK® essentials gloss glazes



Blick® Essentials Gloss Glazes



Cone 06-05
Blick Essentials Gloss Glazes come in a variety of bright, true colors that can be intermixed to create an infinite palette of colors. Non-toxic, non-hazardous, and food safe, these glazes glide smoothly onto bisque, with a self-leveling formula that eliminates brushstrokes from the fired finish. They dry quickly, speeding up handling time and allowing for the application of additional decoration — great for classroom settings. They also won't dissolve or pick up previous coats of glaze. Because they fire to a high gloss finish, no clear glaze is required. ACMI-certified. Pints. Colors can be assorted for quantity pricing.

NUMBER	COLOR	EACH	12/EA
A30482-2026	Black	\$13.90	\$12.50
A30482-3716	Blush	13.90	12.50
A30482-1156	Bright White	13.90	12.50
A30482-4076	Butterscotch	13.90	12.50
A30482-3196	Candy Apple	13.90	12.50
A30482-3226	Cardinal	13.90	12.50
A30482-7916	Clover	13.90	12.50
A30482-8116	Dark Chocolate	13.90	12.50
A30482-5216	Delft Blue	13.90	12.50

NUMBER	COLOR	EACH	12/EA
A30482-3006	Dove Gray	\$13.90	\$12.50
A30482-2606	Elephant Gray	13.90	12.50
A30482-7056	Emerald Isle	13.90	12.50
A30482-2986	Fruit Punch	13.90	12.50
A30482-7176	Granny Smith	13.90	12.50
A30482-3066	Grapefruit	13.90	12.50
A30482-7246	Grass Green	13.90	12.50
A30482-5016	Hydrangea	13.90	12.50
A30482-5206	Indigo	13.90	12.50
A30482-1046	Ivory	13.90	12.50
A30482-7226	Jade	13.90	12.50
A30482-5106	Lagoon	13.90	12.50
A30482-8696	Latte	13.90	12.50
A30482-4066	Lemon	13.90	12.50
A30482-6036	Lilac	13.90	12.50
A30482-4916	Mandarin	13.90	12.50
A30482-8106	Milk Chocolate	13.90	12.50
A30482-6176	Plum	13.90	12.50
A30482-3366	Raspberry	13.90	12.50
A30482-8556	Sand Dune	13.90	12.50
A30482-7846	Sea Green	13.90	12.50
A30482-7426	Seafoam	13.90	12.50
A30482-4516	Sherbet	13.90	12.50
A30482-5076	Sky Blue	13.90	12.50
A30482-3706	Snapdragon	13.90	12.50
A30482-4926	Sunflower	13.90	12.50
A30482-6516	Violet	13.90	12.50

For Ombre Glaze Ceramic Lesson Plan, visit DickBlick.com/project-ideas/ombre-glazed-ceramics/



NUMBER	EACH
A30482-1009	\$73.25

6-Pint Class Pack 1 — Includes one pint each of Bright White, Lemon, Candy Apple, Black, Emerald Isle, and Sky Blue.

6-Pint Class Pack 2 — Includes one pint each of Sherbet, Blush, Lilac, Seafoam, Granny Smith, and Lagoon.

AMACO®



Amaco® LEAD-FREE F-Series Glazes

Cone 05 (1911°F)
America's first lead-free glaze series created in 1950! These vibrant semi-translucent colors fire to a high gloss. All food safe. Formulated for spraying or brushing on bisque. Colors can be assorted for quantity pricing.

NUMBER	COLOR	EACH	24/EA
A30406-2036	F-1 Jet Black	\$19.65	\$17.69
A30406-1026	F-10 Clear Transparent	17.40	15.65
A30406-1006	F-11 White	19.65	17.69
A30406-2616	F-15 Warm Gray	19.65	17.69
A30406-5016	F-20 Light Blue	19.65	17.69
A30406-5046	F-21 Navy	19.65	17.69
A30406-5056	F-22 Royal Blue	19.95	17.95
A30406-5506	F-23 Vivid Blue	19.95	17.95
A30406-5116	F-25 Turquoise	19.95	17.95
A30406-5156	F-26 Aqua	19.65	17.69
A30406-5006	F-27 Nairobi Blue	19.65	17.69
A30406-8106	F-30 Chocolate	19.65	17.69
A30406-7496	F-40 Chrome Green	19.65	17.69
A30406-7016	F-41 Light Green	19.65	17.69
A30406-7486	F-42 Celadon	19.65	17.69
A30406-7226	F-43 Evergreen	19.65	17.69
A30406-7646	F-47 Christmas Tree Green	19.65	17.69
A30406-3176	F-50 Rose	26.75	24.09
A30406-3146	F-52 Burgundy	26.75	24.09
A30406-8516	F-53 Sand	19.65	17.69
A30406-4106	F-54 Peach	19.65	17.69
A30406-3056	F-55 Pink	19.65	17.69
A30406-3246	F-57 Coral	26.50	23.85
A30406-3006	F-58 Red	26.50	23.85
A30406-4086	F-60 Golden Yellow	19.65	17.69
A30406-4066	F-61 Lemon Yellow	19.65	17.69
A30406-8136	F-65 Amber	19.65	17.69
A30406-4506	F-66 Orange	26.50	23.85
A30406-6506	F-70 Violet	26.50	23.85
A30406-3736	F-71 Amethyst	26.50	23.85



For more colors, visit DickBlick.com.

F-Series Glazes Class Packs

Class Pack — 6 Pints (473 ml).

NUMBER	EACH
A30406-0069	\$130.50

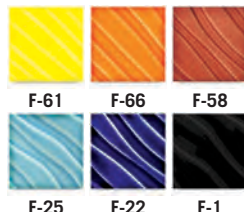

Class Pack — 12 Pints (473 ml).

NUMBER	EACH
A30406-0129	\$242.99

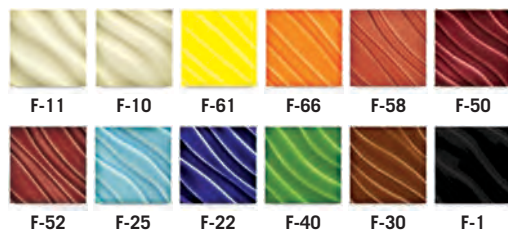

MAYCO®



Mayco® LEAD-FREE Stroke & Coat® WonderGlaze® Kits

Cone 06-05

Kit 1 — SC-6, SC-11, SC-12, SC-13, SC-14, SC-15, SC-16, SC-18, SC-26, SC-36, SC-74, and SC-75.

NUMBER	SET	EACH
A30433-1001	2 oz (60 ml) Bottles	\$38.89
A30433-1010	16 oz (473 ml) Bottles	207.99

Kit 2 — SC-1, SC-3, SC-8, SC-10, SC-15, SC-16, SC-17, SC-20, SC-24, SC-25, SC-28, and SC-30.

NUMBER	SET	EACH
A30433-1002	2 oz (60 ml) Bottles	\$38.89
A30433-1020	16 oz (473 ml) Bottles	207.99

Kit 3 — SC-1, SC-3, SC-6, SC-12, SC-15, SC-16, SC-23, SC-27, SC-31, SC-36, SC-48, and SC-73.

NUMBER	SET	EACH
A30433-1003	2 oz (60 ml) Bottles	\$38.89
A30433-1030	16 oz (473 ml) Bottles	207.99

MAYCO®

Mayco® LEAD-FREE Stroke & Coat® WonderGlaze®

One-Fire Decorating and Glazing! Bisque Firing use Cones 04-03 (1828°-1888°F)
Glaze Firing use Cone 06-Cone 6.

Stroke & Coat is specially formulated for application on bisque or clay. Ready-to-use colors stay true from jar to fired finish. Colors are intermixable. Apply one coat for translucent effects, three coats for rich, opaque coverage. Perfect for controlled application over unfired glazes. All colors and glazes are non-toxic and dinnerware safe. Do not spray-apply. Colors can be assorted for quantity pricing.

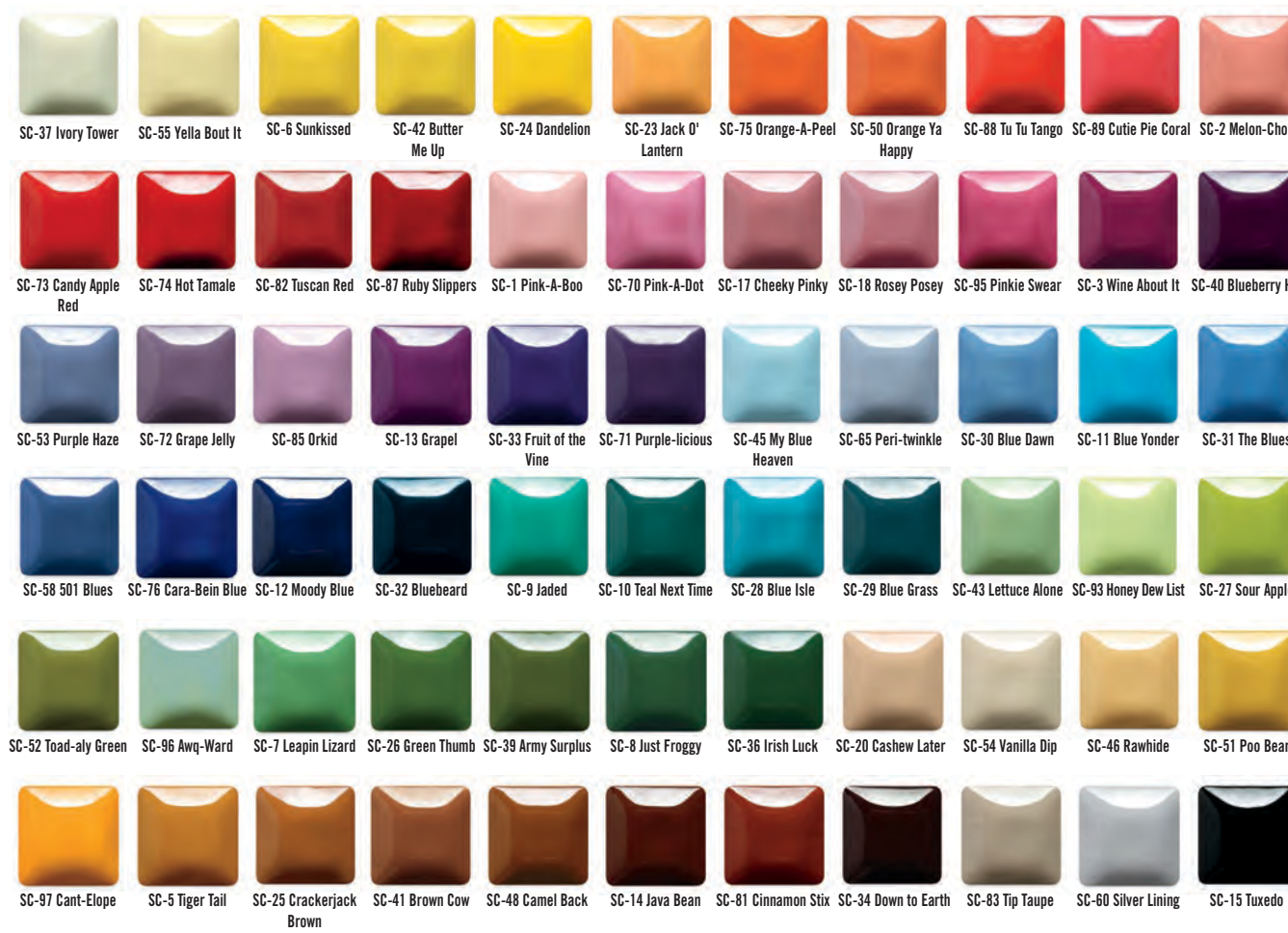

Pints (473 ml) — Squeeze bottles.

NUMBER	COLOR	EACH	12/EA
A30408-3756	SC-1 Pink-A-Boo	\$18.20	\$16.39
A30408-3746	SC-2 Melon-Choly	18.20	16.39
A30408-3806	SC-3 Wine About It	18.20	16.39
A30408-3796	SC-5 Tiger Tail	18.20	16.39
A30408-4936	SC-6 Sunkissed	18.20	16.39
A30408-7946	SC-7 Leapin Lizard	18.20	16.39
A30408-7936	SC-8 Just Froggy	18.20	16.39
A30408-7226	SC-9 Jaded	18.20	16.39
A30408-5956	SC-10 Teal Next Time	18.20	16.39
A30408-5976	SC-11 Blue Yonder	18.20	16.39
A30408-5946	SC-12 Moody Blue	18.20	16.39
A30408-6096	SC-13 Grapel	18.20	16.39
A30408-8916	SC-14 Java Bean	18.20	16.39
A30408-2246	SC-15 Tuxedo	18.20	16.39
A30408-1426	SC-16 Cotton Tail	18.20	16.39
A30408-3726	SC-17 Cheeky Pinky	18.20	16.39
A30408-3766	SC-18 Rosey Posey	18.20	16.39
A30408-8596	SC-20 Cashew Later	18.20	16.39
A30408-4916	SC-23 Jack O' Lantern	18.20	16.39
A30408-4926	SC-24 Dandelion	18.20	16.39
A30408-3736	SC-25 Crackerjack Brown	18.20	16.39
A30408-7916	SC-26 Green Thumb	18.20	16.39
A30408-7956	SC-27 Sour Apple	18.20	16.39
A30408-5856	SC-28 Blue Isle	18.20	16.39
A30408-5936	SC-29 Blue Grass	18.20	16.39
A30408-5926	SC-30 Blue Dawn	18.20	16.39
A30408-5966	SC-31 The Blues	18.20	16.39

Pints (473 ml) — Squeeze bottles.

NUMBER	COLOR	EACH	12/EA
A30408-5916	SC-32 Bluebeard	\$18.20	\$16.39
A30408-6416	SC-33 Fruit of the Vine	18.20	16.39
A30408-2396	SC-34 Down to Earth	18.20	16.39
A30408-2616	SC-35 Gray Hare	18.20	16.39
A30408-7926	SC-36 Irish Luck	18.20	16.39
A30408-1046	SC-37 Ivory Tower	18.20	16.39
A30408-7106	SC-39 Army Surplus	18.20	16.39
A30408-5006	SC-40 Blueberry Hill	18.20	16.39
A30408-8006	SC-41 Brown Cow	18.20	16.39
A30408-4006	SC-42 Butter Me Up	18.20	16.39
A30408-7206	SC-43 Lettuce Alone	18.20	16.39
A30408-5206	SC-45 My Blue Heaven	18.20	16.39
A30408-8106	SC-46 Rawhide	18.20	16.39
A30408-8716	SC-48 Camel Back	18.20	16.39
A30408-4506	SC-50 Orange Ya Happy	18.20	16.39
A30408-4106	SC-51 Poo Bear	18.20	16.39
A30408-7306	SC-52 Toad-aly Green	18.20	16.39
A30408-6006	SC-53 Purple Haze	18.20	16.39
A30408-1106	SC-54 Vanilla Dip	18.20	16.39
A30408-4206	SC-55 Yella Bout It	18.20	16.39
A30408-5306	SC-58 501 Blues	18.20	16.39
A30408-9336	SC-60 Silver Lining	18.20	16.39
A30408-5406	SC-65 Peri-twinkle	18.20	16.39
A30408-3176	SC-70 Pink-A-Dot	18.20	16.39
A30408-6406	SC-71 Purple-licious	18.20	16.39
A30408-6086	SC-72 Grape Jelly	18.20	16.39
A30408-3706	SC-73 Candy Apple Red	18.20	16.39

Pints (473 ml) — Squeeze bottles.

NUMBER	COLOR	EACH	12/EA
A30408-3696	SC-74 Hot Tamale	\$18.20	\$16.39
A30408-4906	SC-75 Orange-A-Peel	18.20	16.39
A30408-5896	SC-76 Cara-Bein Blue	18.20	16.39
A30408-8356	SC-81 Cinnamon Stix	18.20	16.39
A30408-3626	SC-82 Tuscan Red	18.20	16.39
A30408-8316	SC-83 Tip Taupe	18.20	16.39
A30408-6436	SC-85 Orkid	18.20	16.39
A30408-1096	SC-86 Old Lace	18.20	16.39
A30408-3376	SC-87 Ruby Slippers	18.20	16.39
A30408-1001	SC-88 Tu Tu Tango	18.20	16.39
A30408-1002	SC-89 Cutie Pie Coral	18.20	16.39
A30408-1003	SC-93 Honey Dew List	18.20	16.39
A30408-1004	SC-95 Pinkie Swear	18.20	16.39
A30408-1116	SC-96 Awq-ward	18.20	16.39
A30408-4536	SC-97 Cant-elope	18.20	16.39

Mayco® LEAD-FREE Stroke & Coat® Clear Glazes

Brush Glaze — Natural Clear.

NUMBER	SIZE	EACH	12/EA
A30408-1026	Pint (473 ml)	\$9.33	\$8.40
A30408-1029	Gallon (3.78 liter)	34.15	30.75

Dipping Glaze — Natural Clear.

NUMBER	SIZE	EACH	6/EA
A30408-1000	1 Gallon (3.78 liter)	\$34.15	\$30.75
A30408-1005	3 Gallon (11.35 liter)	79.35	71.40

AMACO

Teacher's Palette — 16 mixable colors



Amaco LEAD-FREE Teacher's Choice and Teacher's Palette Glazes Cone 05 (1911°F)

Economical gloss glazes that fire true to their color in the jar, these colors intermix with each other to create an infinite palette. The colors can be layered without bleeding, and they won't flow when fired, so they're great for details. One coat results in a translucent look; use three coats for an opaque look. Choose Teacher's Choice in gallons for larger projects and greater savings. Available in a wide range of colors, Teacher's Palette glazes may appear brighter and more intense, depending on the number of layers applied. All food safe. Colors can be assorted for quantity pricing.

Teacher's Palette — Mixable colors in pints.

NUMBER	COLOR	EACH	24/EA
A30476-2136	TP-1 Coal Black	\$15.25	\$13.75
A30476-1426	TP-11 Cotton	15.25	13.75
A30476-2506	TP-15 Gray	15.25	13.75
A30476-5076	TP-20 Sky Blue	15.25	13.75
A30476-5806	TP-21 Midnight Blue	15.25	13.75
A30476-5106	TP-22 Blue Green	15.25	13.75
A30476-5026	TP-24 Medium Blue	15.25	13.75
A30476-5326	TP-26 Robin's Egg	15.25	13.75
A30476-8346	TP-30 Caramel	15.25	13.75
A30476-8896	TP-32 Fudge Brown	15.25	13.75
A30476-7516	TP-40 Mint Green	15.25	13.75
A30476-7796	TP-41 Frog Green	15.25	13.75
A30476-7786	TP-42 Granny Smith	15.25	13.75
A30476-7156	TP-43 Green Leaf	15.25	13.75
A30476-6096	TP-51 Grape	15.25	13.75
A30476-3366	TP-52 Raspberry	15.25	13.75
A30476-3766	TP-53 Pig Pink	15.25	13.75
A30476-6036	TP-54 Lilac	15.25	13.75
A30476-3086	TP-56 Scarlet	15.25	13.75
A30476-3716	TP-58 Brick Red	15.25	13.75
A30476-4066	TP-60 Lemon	15.25	13.75
A30476-4376	TP-62 Maize	15.25	13.75
A30476-4596	TP-64 Carrot	15.25	13.75
A30476-1006	TP-65 Pumpkin	15.25	13.75



Teacher's Choice — 8 mixable colors in gallons.

NUMBER	COLOR	EACH	6/EA
A30477-2029	TC-1 Black	\$73.05	\$65.75
A30477-1029	TC-11 White	73.05	65.75
A30477-5019	TC-21 Blue	73.05	65.75
A30477-8009	TC-32 Brown	73.05	65.75
A30477-7019	TC-41 Green	73.05	65.75
A30477-3019	TC-58 Red	73.05	65.75
A30477-4019	TC-60 Yellow	73.05	65.75
A30477-4519	TC-64 Orange	73.05	65.75

Teacher's Palette Glazes Class Packs

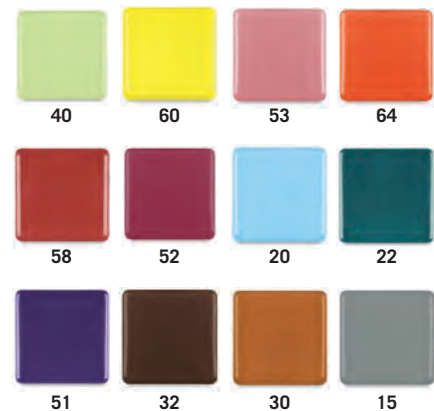

Class Pack No. 3 — 12, 1 pint (473 ml) colors.
 NUMBER EACH
 A30476-1209 \$185.79

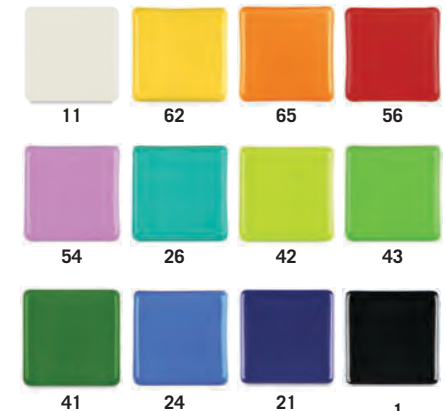

Class Pack No. 5 — 12, 1 pint (473 ml) colors.
 NUMBER EACH
 A30476-1309 \$185.79



Amaco Teacher's Palette Light Low Fire LEAD-FREE Glazes Cone 05 (1911°F)

These translucent gloss glazes break and flow to enhance the texture of a clay body. Their jewel-like colors are vibrant but lend a softer look, allowing the clay color and/or an underglaze to show through. They look especially beautiful over carved or textured surfaces, and also over Amaco Velvet Underglazes. Intermixable with one another and with Amaco Teacher's Palette and Amaco Teacher's Choice glazes. Brush or slip trail for decorative and Majolica-like effects. The colors will not run or bleed, and only blend together if mixed before application. Apply 1-2 coats for more transparency and 2-3 coats for more coverage. Colors can be assorted for quantity pricing.

NUMBER	COLOR	EACH	12/EA
A30579-5266	Aquamarine	\$16.70	\$14.99
A30579-4946	Citrine	16.70	14.99
A30579-7056	Emerald	16.70	14.99
A30579-3126	Fire Opal	16.70	14.99
A30579-3076	Jasper	16.70	14.99
A30579-2216	Onyx	16.70	14.99
A30579-7966	Peridot	16.70	14.99
A30579-1526	Quartz	16.70	14.99
A30579-3376	Ruby	16.70	14.99
A30579-5296	Sapphire	16.70	14.99
A30579-1206	Tanzanite	16.70	14.99
A30579-1106	Zircon	16.70	14.99

12-Pint Class Pack
 NUMBER EACH
 A30579-1006 \$185.50

MAYCO

Mayco LEAD-FREE Jungle Gems Crystal Glazes Cone 06 (1828°F)

Mayco Jungle Gems and Crystalites have merged, creating the largest, most stunning crystal glaze assortment available. The glaze lines share similar chemistry, common glaze applications, and perform alike. Merging these lines simplifies the choice for artists and provides endless creative options. The former Crystalite glazes will retain their names but will be part of the Jungle Gems product line. Jungle Gems contain small pieces of glass frit that transform into splashes of color and patterns when fired. They can be used alone for dramatic effects or be combined with other glazes, such as Mayco Stroke & Coat, to add visual interest. Create your own unique glazes by layering different Crystal Glazes, as the crystals will burst through the glaze surfaces. Colors can be assorted for quantity pricing.



Artwork by Bob Moren
Peacock Feather

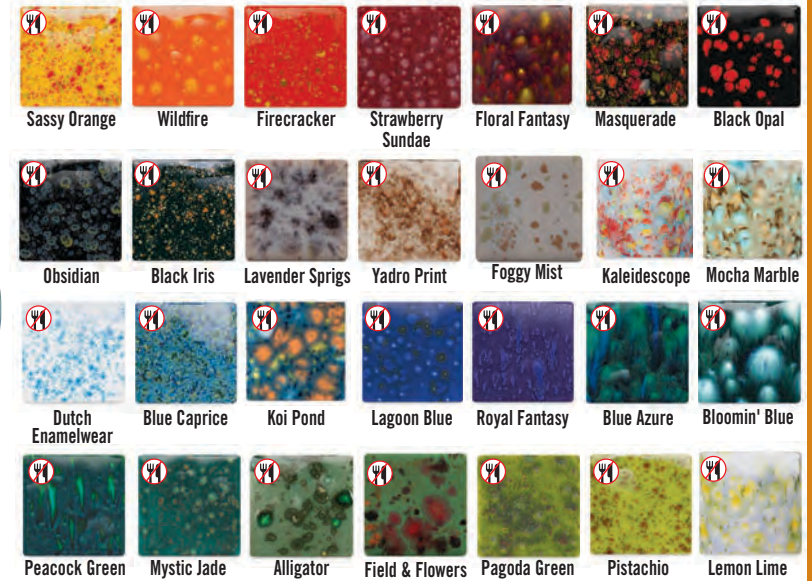

NUMBER	COLOR	EACH	12/EA
A30400-7176	Alligator	\$18.56	\$16.70
A30400-2036	Black Iris	18.56	16.70
A30400-2026	Black Opal	18.56	16.70
A30400-5096	Bloomin' Blue	18.56	16.70
A30400-5916	Blue Azure	18.56	16.70
A30400-5126	Blue Caprice	18.56	16.70
A30455-7510	Cappuccino Mint	19.05	17.15
A30455-5140	Celestial Blue	19.05	17.15
A30455-4910	Citrus Splash	19.05	17.15
A30400-5586	Dutch Enamelwear	18.56	16.70
A30400-1976	Field & Flowers	18.56	16.70
A30400-3116	Firecracker	18.56	16.70
A30400-1966	Floral Fantasy	18.56	16.70
A30400-2006	Foggy Mist	18.56	16.70
A30455-1400	Herb Garden	19.05	17.15
A30400-1866	Kaleidoscope	18.56	16.70
A30400-5166	Koi Pond	18.56	16.70
A30400-5156	Lagoon Blue	18.56	16.70
A30400-6046	Lavender Sprigs	18.56	16.70
A30400-4866	Lemon Lime	18.56	16.70
A30455-7090	Lotus Blossom	19.05	17.15
A30400-1766	Masquerade	18.56	16.70



Mayco LEAD-FREE Speckled Stroke & Coat Cone 06-05 (1828°-1888°F)

An enhanced version of the popular Stroke & Coat Wonderglazes, Speckled Stroke & Coat contains small specks of color that provide visual depth and texture, but won't melt or flow during the glaze firing. Non-toxic and food-safe. Colors can be assorted for quantity pricing.

NUMBER	COLOR	EACH	12/EA
A30408-4956	SP-206 Sunkissed	\$22.35	\$20.10
A30408-5986	SP-211 Blue Yonder	22.35	20.10
A30408-5906	SP-212 Moody Blue	22.35	20.10
A30408-6106	SP-213 Grapel	22.35	20.10
A30408-2236	SP-215 Tuxedo	22.35	20.10
A30408-1436	SP-216 Cotton Tail	22.35	20.10
A30408-7966	SP-227 Sour Apple	22.35	20.10
A30408-3686	SP-274 Hot Tamale	22.35	20.10

NUMBER	COLOR	EACH	12/EA
A30400-7516	Mint Chip	\$18.56	\$16.70
A30400-8766	Mocha Marble	18.56	16.70
A30455-1200	Monsoon Seas	19.05	17.15
A30400-7226	Mystic Jade	18.56	16.70
A30455-1100	Northern Lights	19.05	17.15
A30400-1056	Obsidian	18.56	16.70
A30455-8340	Oriental Carmel	19.05	17.15
A30400-7126	Pagoda Green	18.56	16.70
A30455-5210	Peacock Eyes	19.05	17.15
A30400-7536	Peacock Green	18.56	16.70
A30400-7136	Pistachio	18.56	16.70
A30455-6170	Plum Jelly	19.05	17.15
A30455-4770	Poppy Fields	19.05	17.15
A30400-5056	Royal Fantasy	18.56	16.70
A30455-1300	Safari	19.05	17.15
A30400-4516	Sassy Orange	18.56	16.70
A30400-5146	Seawind	18.56	16.70
A30455-7010	Spotted Kiwi	19.05	17.15
A30400-2046	Spring Rain	18.56	16.70
A30400-3716	Strawberry Sundae	18.56	16.70
A30455-6090	Tahiti Grape	19.05	17.15
A30400-3136	Wildfire	18.56	16.70
A30400-8106	Woodland Fantasy	18.56	16.70
A30400-1076	Yadro Print	18.56	16.70

NOT FOOD SAFE

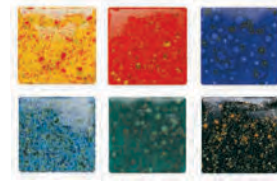

6-Pint Class Pack 1 — Firecracker, Sassy Orange, Blue Caprice, Mystic Jade, Lagoon Blue, and Black Iris.
 NUMBER EACH
 A30400-0019 \$99.45

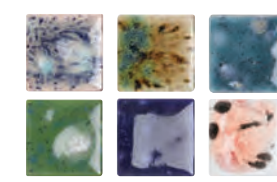

6-Pint Crystalite Class Pack #1 — Northern Lights, Cappuccino Mint, Monsoon Seas, Spotted Kiwi, Celestial Blue, and Poppy Fields.
 NUMBER EACH
 A30454-1001 \$118.09

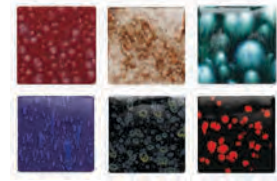

6-Pint Class Pack 2 — Includes Bloomin' Blue, Yadro Print, Strawberry Sundae, Royal Fantasy, Obsidian, and Black Opal.
 NUMBER EACH
 A30400-0029 \$99.45

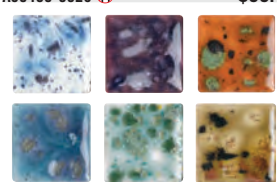

6-Pint Crystalite Class Pack #2 — Peacock Eyes, Plum Jelly, Oriental Carmel, Tahiti Grape, Herb Garden, and Safari.
 NUMBER EACH
 A30454-1002 \$118.09

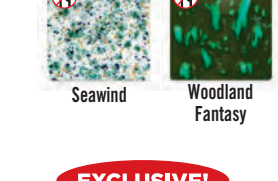

EXCLUSIVE!
BLICK CLASS PACKS!



6-Pint Class Pack 3 — Wildfire, Kaleidoscope, Pistachio, Blue Azure, Floral Fantasy, and Masquerade.
 NUMBER EACH
 A30400-0069 \$99.45

AMACO®

Amaco® LEAD-FREE Matt Glazes

Cone 05 (1911°F)
These ready-to-use liquid glazes can be brushed, poured, dipped, or sprayed onto fired bisque; slow firing is recommended. All colors are opaque except for LM-10. All food safe. Colors can be assorted for quantity pricing.
Pints (473 ml)

NUMBER	COLOR	EACH	12/EA
A30419-2036	LM-1 Satin Black (0)	\$19.55	\$17.60
A30419-1736	LM-10 Translucent Matte	19.55	17.60
A30419-1076	LM-11 Opaque White (0)	19.55	17.60
A30419-8176	LM-13 Terra Cotta (0)	19.55	17.60
A30419-2606	LM-15 Dove Gray (0)	19.55	17.60
A30419-2526	LM-16 Elephant Hide (0)	19.55	17.60
A30419-5916	LM-20 Blue Iris (0)	19.55	17.60
A30419-5076	LM-21 Sky Blue (0)	19.55	17.60
A30419-5326	LM-25 Robin Egg Blue (0)	19.55	17.60
A30419-7636	LM-41 Chartreuse (0)	19.55	17.60
A30419-7916	LM-42 Parakeet Green (0)	19.55	17.60
A30419-7036	LM-46 Dark Green (0)	19.55	17.60
A30419-3056	LM-52 Pink (0)	19.55	17.60
A30419-3246	LM-54 Coral (0)	25.89	23.30
A30419-3006	LM-56 Red (0)	25.89	23.30
A30419-6006	LM-58 Purple (0)	19.55	17.60
A30419-4486	LM-60 Daffodil Yellow (0)	19.55	17.60
A30419-4916	LM-61 Soft Yellow (0)	19.55	17.60
A30419-4466	LM-65 Butterscotch (0)	25.89	23.30
A30419-4506	LM-66 Orange (0)	25.89	23.30
A30419-4636	LM-67 Tangerine (0)	19.55	17.60
A30419-8286	LM-231 Chestnut (0)	19.55	17.60
A30419-5106	LM-244 Blue Green (0)	19.55	17.60



Matt Glazes Class Packs

NUMBER	COLOR	EACH
Class Pack 1 — 6 Pints (473 ml).		
A30419-0069	11 10 60 56 20 42	\$122.75
Class Pack 2 — 6 Pints (473 ml).		
A30419-2006	61 67 13 52 41 21	\$114.25
Class Pack 3 — 12 Pints (473 ml).		
A30419-1012	11 10 60 66 56 58 25 20 42 244 46 1	\$227.15

Amaco® LEAD-FREE Crystaltex Low Fire Glazes

Cone 05 (1911°F)
These glazes contain multi-colored crystals that fan out horizontally or flow down vertical surfaces. Colors can be assorted for quantity pricing.
Pints (473 ml)

NUMBER	COLOR	EACH	12/EA
A30407-2036	CTL-1 Jet Moss	\$26.10	\$23.49
A30407-4916	CTL-9 Snap Dragon	25.85	23.25
A30407-5916	CTL-10 Peppermint Ice	25.85	23.25
A30407-4926	CTL-11 Snow Fire	25.85	23.25
A30407-5936	CTL-12 Mardi Gras	25.85	23.25
A30407-2296	CTL-15 Moon Scape	25.85	23.25
A30407-5956	CTL-20 Royal Turquoise	25.85	23.25
A30407-5946	CTL-22 Milky Way	26.10	23.49
A30407-7836	CTL-26 Sea Mist	25.85	23.25
A30407-8926	CTL-35 Nutmeg	26.10	23.49
A30407-8906	CTL-36 Ginger Bread	26.10	23.49
A30407-7926	CTL-41 Melon	26.10	23.49
A30407-8846	CTL-42 Fantasia	26.10	23.49
A30407-5236	CTL-46 Ultra Jewel	25.85	23.25
A30407-4406	CTL-48 Sun and Sea	26.10	23.49
A30407-6416	CTL-49 Azurite	26.10	23.49
A30407-3716	CTL-54 Firecracker	26.10	23.49
A30407-4466	CTL-61 Buttercup	26.10	23.49
A30407-4556	CTL-67 Summer Mango	26.10	23.49
A30407-1026	CTL-70 Magnolia Jewel	26.10	23.49
A30407-6496	CTL-71 Purple Blaze	26.10	23.49



CTL-11 Snow Fire

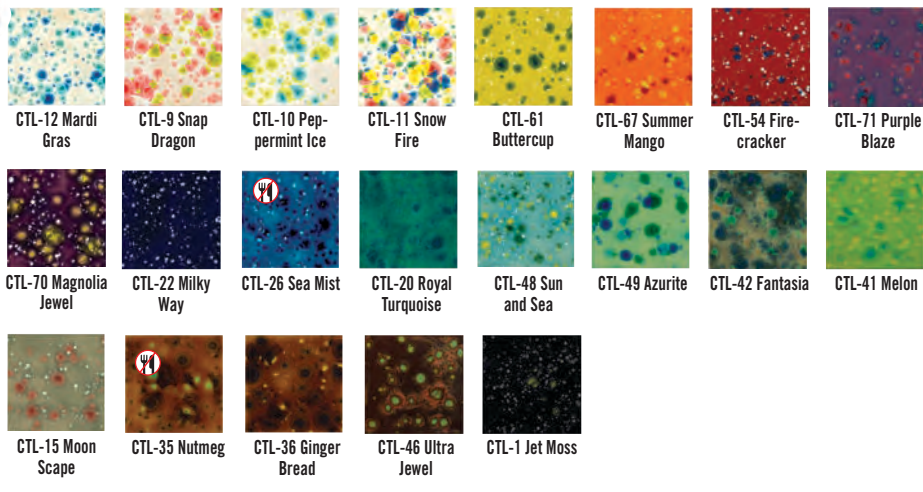

Crystaltex Glazes Class Packs

NUMBER	COLOR	EACH
Class Pack 1 — 12 Pints (473 ml).		
A30407-0129	12 9 10 11 54 22 26 20 15 41 35 1	\$291.15
Class Pack 2 — 6 Pints (473 ml).		
A30407-1069	10 61 54 41 22 1	\$150.99
Class Pack 3 — 6 Pints (473 ml).		
A30407-1003	67 42 35 46 49 70	\$150.99
Class Pack 4 — 12 Pints (473 ml).		
A30407-1004	12 67 15 36 54 71 70 41 48 49 46 61	\$291.15

NOT FOOD SAFE

HEALTH & SAFETY ICONS: ●=CL / ■=Prop 65 / ▼=CL & Prop 65 See page 644 for more information.

AMACO®

Amaco® LEAD-FREE Artist's Choice Glazes

Cone 05 (1911°F)
Newly reformulated for red clays — the color in the clay will partially show through the texture and add another color dimension to the glaze. Reduction looks in low-fire electric kilns. All food safe. Colors can be assorted for quantity pricing.
Pints (473 ml) — A-Series.

NUMBER	COLOR	EACH	12/EA
A30452-5116	A-22 Aztec Turquoise	\$14.69	\$13.25
A30452-5816	A-24 Exotic Blue	14.69	13.25
A30452-5216	A-28 Peacock	14.69	13.25
A30452-2126	A-32 Iron Saturate	14.69	13.25
A30452-8546	A-34 Sand Bar	14.69	13.25
A30452-7926	A-40 Seafoam Green	14.69	13.25
A30452-7196	A-43 Green Float	14.69	13.25
A30452-3716	A-52 Old Brick	19.50	17.55
A30452-8196	A-61 Moss Brown	19.50	17.55
A30452-8716	A-62 Camel	14.69	13.25
A30452-4706	A-66 Burnt Orange	19.50	17.55

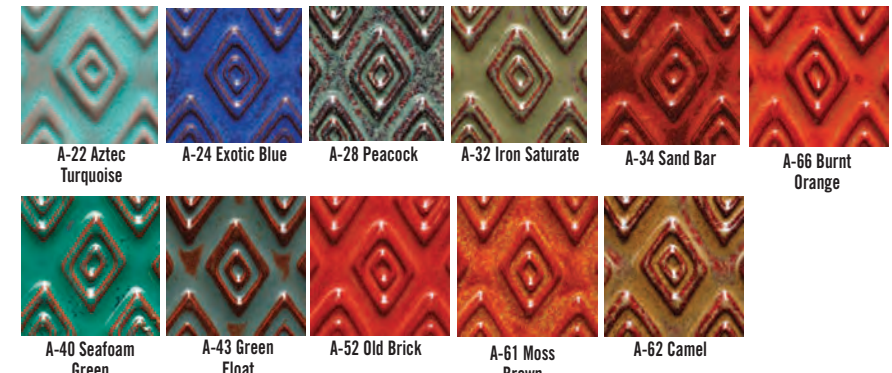

Artist's Choice Glazes Class Packs

NUMBER	COLOR	EACH
Class Pack Set 1 — 6 Pints (473 ml).		
A30452-1069	22 24 28 32 40 62	\$83.85
Class Pack Set 2 — 6 Pints (473 ml).		
A30452-2069	24 34 43 52 61 66	\$98.35

Amaco® LEAD-FREE Raku Glazes

Cone 05 (1911°F)
These liquid raku glazes are lead-free and formulated to create dazzling effects and varied surfaces on non-functional pottery and sculpture. No two finished pieces will ever be the same because the metals and colorants of the glazes are brought to the surface by flame and reduction. R-10, R-11, and R-20 are transparent and sprayable. All other colors are opaque, except for R-18, which is translucent.
Pints (473 ml)

NUMBER	COLOR	EACH	12/EA
A30453-1606	R-10 Clear Crackle	\$16.55	\$15.35
A30453-1026	R-11 White Crackle	16.55	15.35
A30453-5916	R-12 Blue Bell	16.55	15.35
A30453-5516	R-13 Smokey Blue	16.55	15.35
A30453-6036	R-14 Smokey Lilac	16.55	15.35
A30453-9266	R-15 Caribbean Blue	16.55	15.35
A30453-9506	R-16 Copper Patina	16.55	15.35
A30453-9336	R-17 Tarnished Silver	16.55	15.35
A30453-9516	R-18 Lustrous Copper	16.55	15.35
A30453-9526	R-19 Copper Matte	16.55	15.35
A30453-3016	R-20 Red Crackle	16.55	15.35



NOT FOOD SAFE

Amaco® LEAD-FREE Opalescent Glazes

Cone 05 (1911°F/1044°C)
Iridescent pearl-like colors that flow and pool in texture. For best results, use them over a contrasting colored underglaze or clay body. (Shown here on red clay.) All food safe. Colors can be assorted for quantity pricing.
Pints (473 ml)

NUMBER	COLOR	EACH	24/EA
A30428-2616	O-2 Black Tulip	\$19.30	\$17.35
A30428-1756	O-10 Transparent Pearl	19.30	17.35
A30428-1436	O-11 White Clover	19.30	17.35
A30428-8916	O-12 Tawny	19.30	17.35
A30428-5916	O-20 Blue Bell	19.30	17.35
A30428-5366	O-21 Aquamarine	19.30	17.35
A30428-5296	O-23 Sapphire Blue	19.30	17.35
A30428-5116	O-26 Turquoise	19.30	17.35
A30428-8576	O-30 Autumn Leaf	19.30	17.35
A30428-7526	O-42 Moss Green	19.30	17.35
A30428-3716	O-52 Fuchsia	19.30	17.35
A30428-8826	O-54 Dusty Rose	19.30	17.35
A30428-3726	O-57 Mottled Burgundy	19.30	17.35



NUMBER	COLOR	EACH
Opalescent Glazes Class Pack — 6 Pints (473 ml).		
A30428-0069	20 21 23 26 30 52	\$106.89



WARNING! Products marked with a Prop 65 symbol (■ or ▼) can expose you to chemicals, including cadmium, which are known to the State of California to cause cancer and birth defects or other reproductive harm. For more information, visit P65Warnings.ca.gov.

MAYCO

Mayco Elements™ Glazes

Cone 06-05 (1828°-1888°F)

Designed to simulate the aesthetic, movement, and interest of mid-range and high-fire glazes in a Cone 06/05 oxidation kiln firing, Mayco Elements Glazes produce lush, organic, earthy hues inspired by nature. The application, firing temperature, and shape of each pottery piece will influence the outcome of the finished work. Surfaces may vary from gloss to matte, with subtle variations occurring in each color for a truly one-of-a-kind look. These glazes can also be combined or layered to create unique hues.

Pints (473 ml)

NUMBER	COLOR	EACH	12/EA
A30443-8576	Autumn	\$15.25	\$13.75
A30443-7236	Aztec Jade	15.25	13.75
A30443-2026	Black Adventurine	15.25	13.75
A30443-1006	Cactus Flower	15.25	13.75
A30443-8426	Creek Bed	15.25	13.75
A30443-7316	Dark Amethyst	15.25	13.75
A30443-7256	Evergreen Fir	15.25	13.75
A30443-8406	Ginger Root	15.25	13.75
A30443-7246	Grass	15.25	13.75
A30443-7056	Green Sapphire	15.25	13.75
A30443-5266	Lapis Lagoon	15.25	13.75
A30443-7916	Lustre Green	15.25	13.75
A30443-5546	Mirror Blue	15.25	13.75
A30443-8336	Rare Earth	15.25	13.75
A30443-2686	Rain Cloud	15.25	13.75
A30443-3716	Rose Granite	15.25	13.75
A30443-3476	Rust Red	15.25	13.75
A30443-8556	Sahara Sands	15.25	13.75
A30443-7846	Sea Green	15.25	13.75
A30443-2606	Slate	15.25	13.75
A30443-8386	Toasted Almond	15.25	13.75
A30443-2616	Turtle Shell	15.25	13.75
A30443-8926	Wheat	15.25	13.75

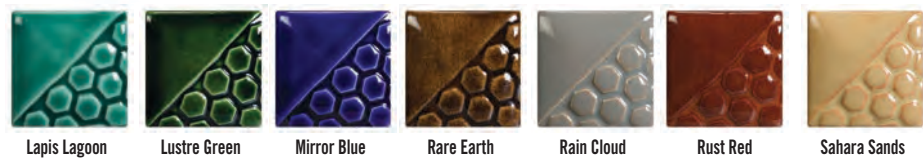

NEW! Spectrum™ Low Fire Metallic Glazes

Ideal for creating decorative and special effects on pottery, this range includes six glazes that give the appearance of brushed bronze, wrought iron, green patina, and more. Final appearance depends on the color of the clay body, the thickness of the glaze application, and the firing temperature. Lead free but not food safe. Fire to Cone 05.

NUMBER	COLOR	SIZE	EACH	12/EA
A30596-8156	152 Brushed Bronze	Pint	\$18.69	\$16.80
A30596-4076	151 Golden Halo	Pint	18.69	16.80
A30596-7846	153 Green Mirror	Pint	18.69	16.80
A30596-7586	156 Green Patina	Pint	18.69	16.80
A30596-2176	152 Moonlight	Pint	18.69	16.80
A30596-7926	154 Wrought Iron	Pint	18.69	16.80

Set of 6 — Includes 1 pint each of all 6 colors above.

NUMBER	SIZE	EACH
A30596-1069	pint	\$101.19

HEALTH & SAFETY ICONS: ●=CL / ■=Prop 65 / ▼=CL & Prop 65
See page 644 for more information.



Duncan™ Precious Metals Overglazes

Cone 019-018 (1283°F-1353°F)

Real precious metals applied to fired glazed ware as a final finish, these overglazes are opaque when applied, and result in brilliant 22 karat yellow gold or white gold finishes when fired. Bright Gold and White Gold contain 4% 22 karat gold content. Premium Gold contains 8% 22 karat gold content, producing a truer gold color. Fire to Cone 019-018. Follow instructions carefully for best results. Food safe after firing. 2 g glass bottles. Colors can be assorted for quantity pricing.

NUMBER	COLOR	EACH	12/EA
A30574-9140	Bright Gold	\$36.35	\$32.72
A30574-9260	Premium Gold	49.58	46.62
A30574-1280	White Gold	36.35	32.72

534 ceramics 800.447.8192 to order

AMACO



Amaco™ Satin Matte LEAD-FREE Mid/High-Fire Glazes

Food safe! Cone 5-6 (2205°-2269°F)

A palette of opaque glazes that break slightly over edges and texture, with a soft satin feel. Formulated to be 100% mixable for tint, shade, and color. Use Clear Satin to lighten color tones. All colors are sprayable. AP non-toxic.

Pints (473 ml)

NUMBER	COLOR	EACH	12/EA
A30494-2026	SM-1 Black	\$16.90	\$15.20
A30494-1006	SM-10 Clear Satin	16.90	15.20
A30494-1026	SM-11 White	16.90	15.20
A30494-5026	SM-20 Light Blue	16.90	15.20
A30494-5036	SM-21 Dark Blue	16.90	15.20
A30494-5086	SM-27 Teal	16.90	15.20
A30494-5106	SM-29 Blue Green	16.90	15.20
A30494-7516	SM-42 Mint	16.90	15.20
A30494-1106	SM-44 Chartreuse	16.90	15.20
A30494-3016	SM-51 Red	16.90	15.20
A30494-4016	SM-63 Yellow	16.90	15.20
A30494-4516	SM-68 Orange	16.90	15.20



Class Pack #1 — This set of six pints includes one each of SM-1 Black, SM-11 White, SM-21 Dark Blue, SM-44 Chartreuse, SM-51 Red, and SM-68 Orange.

NUMBER	EACH
A30494-1001	\$90.74

Class Pack #2 — This set of six pints includes one each of SM-10 Clear Satin, SM-20 Light Blue, SM-27 Teal, SM-29 Blue Green, SM-42 Mint, and SM-63 Yellow.

NUMBER	EACH
A30494-1002	\$90.74

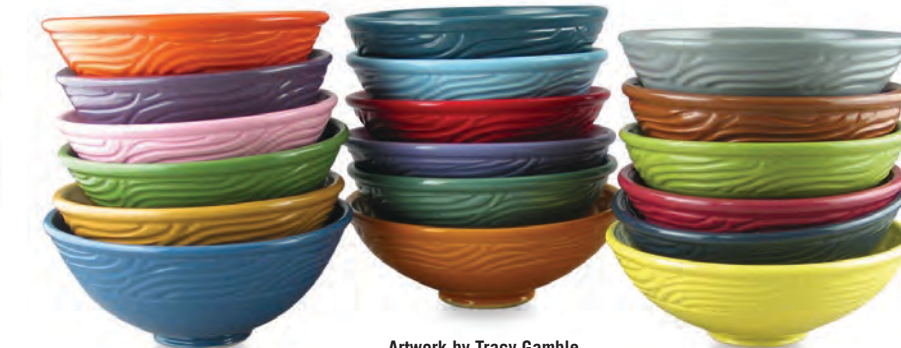
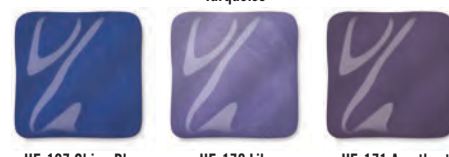
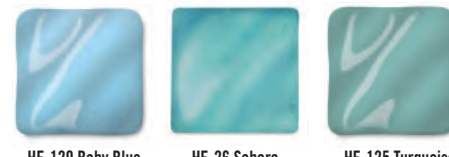
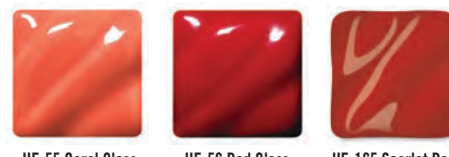
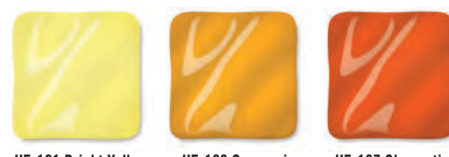

Artwork by Tracy Gamble

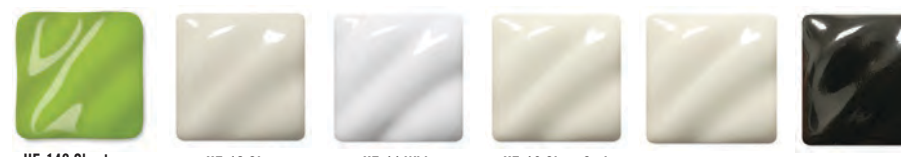

Amaco™ LEAD-FREE High-Fire Glazes

Food safe! Cone 5-6 (2205°-2269°F)

Developed for use on stoneware, these glazes are a beautiful collection of bright and pastel colors that are as colorful as earthenware glazes. The final appearance will change depending on the clay body to which they're applied. These glazes are great when used with contrasting colors, next to, or on top of one another. Excellent results can also be achieved when used over Potter's Choice glazes. Colors can be assorted for quantity pricing.



Pints (473 ml)

NUMBER	COLOR	EACH	12/EA
A30440-2020	HF-1 Black	\$14.54	\$13.08
A30440-1000	HF-9 Zinc Free Clear	14.54	13.08
A30440-1010	HF-10 Clear	14.54	13.08
A30440-1030	HF-11 White	14.54	13.08
A30440-1020	HF-12 Clear Satin	14.54	13.08
A30440-5120	HF-26 Sahara Turquoise	14.54	13.08
A30440-4920	HF-55 Coral Gloss	31.85	28.66
A30440-3010	HF-56 Red Gloss	31.85	28.66
A30458-5116	HF-125 Turquoise	18.04	16.24

NUMBER	COLOR	EACH	12/EA
A30458-5156	HF-127 China Blue	\$27.25	\$24.52
A30458-5356	HF-129 Baby Blue	18.04	16.24
A30458-7636	HF-142 Chartreuse	27.25	24.52
A30458-4296	HF-161 Bright Yellow	27.25	24.52
A30458-3086	HF-165 Scarlet Red	31.85	28.66
A30458-4516	HF-166 Orangerie	31.85	28.66
A30458-1006	HF-167 Clementine	31.85	28.66
A30458-6036	HF-170 Lilac	31.85	28.66
A30458-3716	HF-171 Amethyst	31.85	28.66

WARNING! Products marked with a Prop 65 symbol (■ or ▼) can expose you to chemicals, including cadmium, which are known to the State of California to cause cancer and birth defects or other reproductive harm. For more information, visit P65Warnings.ca.gov.



Amaco® Celadon LEAD-FREE Mid/High-Fire Glazes



Cone 5-6 (2205°-2269°F)

Amaco's high-fire celadon glazes are transparent gloss glazes formulated to be 100% mixable. Create your own "celadons" from a palette of 17 hues.

Celadon highlights surface textures and brings out the color of the clay. Use C-11 Mixing Clear to adjust transparency and soften colors. Thin with water and Amaco Gum Solution if needed. Shake well before use. Apply three coats of glaze to Cone 04 bisque (let glaze dry between coats). Food safe. AP colors are safe for spray application. **Colors can be assorted for quantity pricing.**

Pints (473 ml)		EACH	12/EA
A30489-1016	C-1 Obsidian	\$15.65	\$14.09
A30489-2646	C-3 Smoke	15.65	14.09
A30489-2136	C-5 Charcoal	15.65	14.09
A30489-1186	C-10 Snow	15.65	14.09
A30489-2006	C-11 Mixing Clear	15.65	14.09
A30489-5576	C-19 Glacier	15.65	14.09
A30489-5186	C-20 Cobalt	15.65	14.09
A30489-5076	C-21 Sky	15.65	14.09
A30489-5246	C-22 Fog	15.65	14.09
A30489-5566	C-23 Ice	15.65	14.09
A30489-5926	C-25 Downpour	15.65	14.09
A30489-5916	C-27 Storm	15.65	14.09
A30489-5176	C-29 Deep Sea	15.65	14.09
A30489-4046	C-32 Ochre	15.65	14.09
A30489-3766	C-36 Iron	15.65	14.09
A30489-5166	C-40 Aqua	15.65	14.09
A30489-7376	C-41 Pear	15.65	14.09
A30489-1006	C-43 Wasabi	15.65	14.09
A30489-7226	C-47 Jade	15.65	14.09
A30489-7026	C-49 Rainforest	15.65	14.09
A30489-1036	C-50 Cherry Blossom	15.65	14.09
A30489-6176	C-53 Weeping Plum	15.65	14.09
A30489-3716	C-54 Snapdragon	15.65	14.09
A30489-3616	C-55 Poppy	15.65	14.09
A30489-6046	C-56 Lavender	15.65	14.09
A30489-3596	C-57 Mulberry	15.65	14.09
A30489-4916	C-60 Marigold	15.65	14.09
A30489-4636	C-65 Tangelo	15.65	14.09

Gallon			
NUMBER	COLOR	EACH	3/EA
A30489-1019	C-1 Obsidian	\$80.75	\$72.69
A30489-1189	C-10 Snow	80.75	72.69
A30489-2009	C-11 Mixing Clear	80.75	72.69
A30489-5189	C-20 Cobalt	80.75	72.69
A30489-5079	C-21 Sky	80.75	72.69
A30489-5919	C-27 Storm	80.75	72.69

10 lb Dry			
NUMBER	COLOR	EACH	3/EA
A30489-1011	C-1 Obsidian	\$98.55	\$88.70
A30489-2641	C-3 Smoke	98.55	88.70
A30489-2131	C-5 Charcoal	98.55	88.70
A30489-1181	C-10 Snow	98.55	88.70
A30489-2001	C-11 Mixing Clear	98.55	88.70
A30489-5571	C-19 Glacier	98.55	88.70
A30489-5181	C-20 Cobalt	98.55	88.70
A30489-5071	C-21 Sky	98.55	88.70
A30489-5241	C-22 Fog	98.55	88.70
A30489-5561	C-23 Ice	98.55	88.70
A30489-5921	C-25 Downpour	98.55	88.70
A30489-5911	C-27 Storm	98.55	88.70
A30489-5171	C-29 Deep Sea	98.55	88.70
A30489-4041	C-32 Ochre	98.55	88.70
A30489-3761	C-36 Iron	98.55	88.70
A30489-5161	C-40 Aqua	98.55	88.70
A30489-7371	C-41 Pear	98.55	88.70
A30489-1005	C-43 Wasabi	98.55	88.70
A30489-7221	C-47 Jade	98.55	88.70
A30489-7021	C-49 Rainforest	98.55	88.70
A30489-1031	C-50 Cherry Blossom	98.55	88.70
A30489-6171	C-53 Weeping Plum	98.55	88.70
A30489-3711	C-54 Snapdragon	98.55	88.70
A30489-3611	C-55 Poppy	98.55	88.70
A30489-6041	C-56 Lavender	98.55	88.70
A30489-3591	C-57 Mulberry	98.55	88.70
A30489-4911	C-60 Marigold	98.55	88.70
A30489-4631	C-65 Tangelo	98.55	88.70

Class Pack #1 — 6 Pints (473 ml), including C-11 Clear, C-22 Fog, C-23 Ice, C-27 Storm, C-40 Aqua, and C-43 Wasabi.			
NUMBER	SIZE	EACH	
A30489-1001	12 Pints	\$180.69	



Class Pack #2 — 12 Pints (473 ml), including C-1 Snow, C-10 Obsidian, C-20 Cobalt, C-21 Sky, C-36 Iron, C-41 Pear, C-47 Jade, C-49 Rainforest, C-50 Cherry Blossom, C-53 Weeping Plum, C-56 Lavender, and C-60 Marigold.

NUMBER	SIZE	EACH
A30489-1002	12 Pints	\$180.69



Class Pack #3 — 12 pints (473 ml), including C-3 Smoke, C-5 Charcoal, C-10 Snow, C-11 Clear, C-19 Glacier, C-25 Downpour, C-29 Deep Sea, C-32 Ochre, C-40 Aqua, C-41 Pear, C-55 Poppy, and C-65 Tangelo.

NUMBER	SIZE	EACH
A30489-1003	12 Pints	\$180.69

Did you know we have hundreds of lesson plans designed to meet the National Standards for Visual Arts Education? See them all at DickBlick.com/lesson-plans.



Amaco® Potter's Choice LEAD-FREE High-Fire Glazes



Cone 5-6 (2205°-2269°F)

A collection of favorite potter's colors formulated to achieve Cone 10 reduction surfaces from Cone 5-6 oxidation firings! The finishes are stunning and authentic. Layer these glazes to create your own unique look. For layering tips and 100 combinations to preview, visit DickBlick.com. Pint (473 ml) and gallon sizes in liquid form. **Colors can be assorted for quantity pricing.**

COLOR	PINT (473 ML) LIQUID	EACH	24/EA
PC-1 Saturation Metallic	A30446-1016	\$26.99	\$24.29
PC-2 Saturation Gold	A30446-9126	16.99	15.70
PC-4 Palladium	A30446-1086	18.75	16.89
PC-12 Blue Midnight	A30446-5806	16.99	15.70
PC-20 Blue Rutile	A30446-5016	16.99	15.70
PC-21 Arctic Blue	A30446-5026	16.99	15.70
PC-23 Indigo Float	A30446-5206	16.99	15.70
PC-24 Sapphire Float	A30446-5296	18.75	16.89
PC-25 Textured Turquoise	A30446-5126	16.99	15.70
PC-27 Tourmaline	A30446-3736	16.99	15.70
PC-28 Frosted Turquoise	A30446-5916	18.75	16.89
PC-29 Deep Olive Speckle	A30446-7916	18.75	16.89
PC-30 Temmoku	A30446-1056	16.99	15.70
PC-31 Oatmeal	A30446-1126	16.99	15.70
PC-32 Albany Slip Brown	A30446-8136	18.75	16.89
PC-33 Iron Lustre	A30446-3776	16.99	15.70
PC-34 Light Sepia	A30446-8086	16.99	15.70
PC-36 Ironstone	A30446-7926	16.99	15.70
PC-37 Smoked Sienna	A30446-1096	16.99	15.70
PC-39 Umber Float	A30446-8536	16.99	15.70
PC-40 True Celadon	A30446-7486	16.99	15.70
PC-41 Vert Lustre	A30446-1106	16.99	15.70
PC-42 Seaweed I	A30446-7116	16.99	15.70
PC-43 Toasted Sage	A30446-7406	16.99	15.70
PC-44 Sage	A30446-7416	16.99	15.70
PC-45 Dark Green	A30446-7036	16.99	15.70
PC-46 Lustrous Jade	A30446-7226	16.99	15.70
PC-48 Art Deco Green	A30446-7906	18.75	16.89
PC-49 Frosted Melon	A30446-4916	16.99	15.70
PC-50 Shino	A30446-1066	16.99	15.70
PC-52 Deep Sienna Speckle	A30446-1926	18.75	16.89
PC-53 Ancient Jasper	A30446-1206	16.99	15.70
PC-55 Chun Plum	A30446-6176	18.75	16.89
PC-57 Smokey Merlot	A30446-2906	18.75	16.89
PC-59 Deep Firebrick	A30446-3126	18.75	16.89
PC-61 Textured Amber	A30446-8116	16.99	15.70
PC-63 Cosmic Tea Dust	A30446-8936	16.99	15.70
PC-64 Aventurine	A30446-7246	16.99	15.70
PC-71 Flambe	A30446-3006	18.75	16.89

GALLON LIQUID	EACH	4/EA
A30446-1019	\$128.25	\$115.50
A30446-9129	81.99	73.79
A30446-1089	81.99	73.79
A30446-5809	81.99	73.79
A30446-5019	81.99	73.79
A30446-5029	81.99	73.79
A30446-5209	81.99	73.79
A30446-5129	81.99	73.79
A30446-3739	81.99	73.79
A30446-7919	81.99	73.79
A30446-1059	81.99	73.79
A30446-1129	81.99	73.79
A30446-8139	107.49	96.75
A30446-3779	81.99	73.79
A30446-8089	81.99	73.79
A30446-7929	81.99	73.79
A30446-7489	81.99	73.79
A30446-1109	81.99	73.79
A30446-7119	81.99	73.79
A30446-7409	81.99	73.79
A30446-7039	81.99	73.79
A30446-7229	81.99	73.79
A30446-7909	107.49	96.75
A30446-1929	81.99	73.79
A30446-1209	81.99	73.79
A30446-6179	107.49	96.75
A30446-2909	107.49	96.75
A30446-3009	104.75	94.25



Class Pack No.1 — 6 Pints (473 ml).

NUMBER	SIZE	EACH
A30446-1001	6 Pints	\$104.75

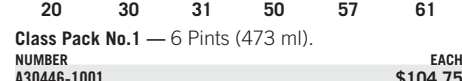

Class Pack No.2 — 6 Pints (473 ml).

NUMBER	SIZE	EACH
A30446-1002	6 Pints	\$104.75

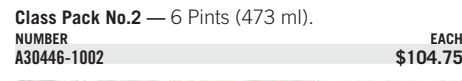

Class Pack No.3 — 6 Pints (473 ml).

NUMBER	SIZE	EACH
A30446-1003	6 Pints	\$104.75

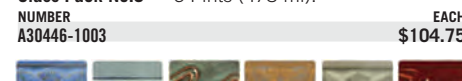

Class Pack No.4 — 6 Pints (473 ml).

NUMBER	SIZE	EACH
A30446-1004	6 Pints	\$104.75





Latex-Powdered Disposable Gloves

Industrial-quality powdered natural rubber gloves deliver superb tactile sensitivity for complex tasks. pH-balanced; treated with absorbable dusting powder. Pack of 100.

NUMBER	SIZE	EACH	10/EA
A35200-1010	Small	\$18.33	\$16.50
A35200-1020	Medium	18.33	16.50
A35200-1030	Large	18.33	16.50
A35200-1040	X-Large	18.33	16.50



Nitrile Powder-Free Disposable Gloves

Ideal for working with solvents, nitrile is chemical-resistant and helps dissipate electrostatic charges. These gloves are powder-free and allergen-free. Pack of 100.

NUMBER	SIZE	EACH	10/EA
A35200-1090	Small	\$34.99	\$31.49
A35200-1100	Medium	34.99	31.49
A35200-1110	Large	34.99	31.49
A35200-1120	X-Large	34.99	31.49



Disposable Plastic Gloves

Economical and disposable, these thin plastic gloves protect hands from paint, ink, glue, and other messy liquids. Box of 100.

NUMBER	SIZE	EACH	12/EA	24/EA
A04982-1020	Small-Med	\$4.90	\$4.41	\$4.17
A04982-1010	Large-XL	4.90	4.41	4.17



SemperForce Black Nitrile Gloves

Designed for demanding work environments where safety and comfort are a must, these gloves are textured for enhanced dexterity and grip. Ideal for automotive, industrial, tattoo, and cosmetology applications. For additional features, visit DickBlick.com

NUMBER	DESCRIPTION	EACH	10/EA
A03484-2020	Small	\$35.55	\$31.99
A03484-2021	Medium	35.55	31.99
A03484-2022	Large	35.55	31.99
A03484-2023	Extra Large	35.55	31.99



Safety Goggles

These comfortable safety goggles have high-quality optics and can be worn over most glasses.

NUMBER	EACH	12/EA
A61705-1001	\$5.99	\$5.36

SAS' Standard Face Shield

Made of impact-resistant polycarbonate for long-lasting protection. Curved design protects a larger area of the face without distortion. Suitable for grinding applications as well as general studio use. Meets ANSI Z87.1-2010 standards. Replacement shield (without headgear) sold separately.

NUMBER	DESCRIPTION	EACH	12/EA
A04833-1001	Face Shield	\$29.13	\$26.21
A04833-1002	Replacement Shield (no headgear)	12.31	11.08



3M' Easy-Care™ Respirator Assembly

Includes one organic vapor facepiece, two pre-filters, two pre-filter retainers, and instructions. Approvals and limitations printed on box. Use for mists of paints, lacquers and enamels, pesticides, and dusts and mists having permissible exposure limits. NIOSH/MSHA approved.

NUMBER	DESCRIPTION	EACH	5/EA
A34911-0300	Respirator, Size M	\$53.58	\$48.23
A34911-0200	Pre-Filters, Pack of 10	33.52	30.16



3M' Easi-Air™ Paint Spray Respirator Assembly

Includes two organic vapor cartridges, two paintspray filters, and one silicone facepiece. NIOSH/MSHA approved for respiratory protection against mists of lacquers, enamels, and other paints. Includes instructions for use, approval labels, and product limitations.

NUMBER	DESCRIPTION	EACH	5/EA
A34911-0400	Medium	\$73.20	\$65.88
A34911-0500	Large	73.20	65.88
A34911-1019	Cartridges, Pack of 2	26.11	23.50



Glovies' Disposable Gloves for Kids

Keep little hands clean! Made with waterproof plastic and designed just for kids, Glovies are latex-free, powder-free disposable gloves. Use them for finger painting, tie-dye, papier mâché, and other messy arts and crafts. When the fun is over, just remove the gloves and throw the mess away. For ages 2 to 9. Box of 100.

NUMBER	EACH
A03480-1001	\$14.19

SAS' Standard Safety Goggles

Economical eye protection for the studio or classroom. Made of flexible PVC with an impact-resistant polycarbonate lens, they are comfortable, durable, and offer 99.9% UV protection. They meet ANSI Z87.1-2010 standards.

NUMBER	EACH	12/EA
A04835-1001	\$3.92	\$3.53

SAS' N95 Particulate Respirator

Offers 95% efficient respiratory protection in non-oil areas. Features a latex-free, sonically welded fixed head strap and adjustable nose clip with foam strip to reduce fogging. NIOSH approved.

NUMBER	EACH	12/EA
A04837-1001	\$27.72	\$24.95



SAS' Safety Emergency Eyewash Station

This portable, gravity-fed eyewash station is ideal for any space where hazardous materials are present. It provides a minimum 15-minute flushing period. Holds 9.11 gallons of water and has a lockable cap. Features one-hand operation and doesn't require plumbing. Includes a mounting bracket, inspection tag, and preservative. Measures approximately 9-1/2" x 16-1/2" x 20". ANSI Z358.1-2014 compliant.

NUMBER	DESCRIPTION	EACH
A49225-1001	Eyewash Station	\$262.49
A49225-1002	Inspection Tag	2.53
A49225-1003	Preservative, 4 oz	8.99



A SAS' Safety First Aid Kits

Single Person — This personal kit is compact and lightweight. Ideal for traveling, workshops, minor sports injuries, and recreational needs, it contains 39 pieces. Its 3-3/4" x 5" x 1-1/2" size is perfect for storing in a backpack, toolbox, athletic bag, or glove compartment.

NUMBER	EACH	4/EA
A49231-1002	\$8.20	\$7.38

25 Person — Perfect for workplaces, classrooms, and art rooms with up to 25 people, this kit contains 140 pieces. It's can also be used for light-to-medium industry, contractors, and job sites. This box is 1/2" x 7-1/2" x 2-3/4" and is able to mount to a wall.

NUMBER	EACH	4/EA
A49231-1001	\$24.29	\$21.85

B SAS' Safety Foam Ear Plugs

Pre-shaped ear plugs made of super soft foam that conforms to the inner ear canal for comfort and effectiveness. They come with two pairs, corded and uncorded, and individual storage cases. With a Noise Reduction Rating of 31, their noise reducing abilities help prevent permanent hearing loss in situations with high levels of noise.

NUMBER	EACH	12/EA
A49232-1001	\$3.12	\$2.81



C-E Sandusky Lee' Safety Cabinets

Make sure your classroom or studio is compliant by using these sturdy cabinets to safely store flammable materials such as paints and solvents. A 1-1/2" air space between two 18-gauge welded steel walls and dual 2" capped vents keep contents cooler than standard cabinets. Smaller models mount conveniently under countertops, fume hoods, windows, and other compact areas to free up valuable floor space. Adjustable feet keep cabinets level, important when storing liquids. Shelves hold up to 500 lb. Bright yellow powder-coated finish with "Flammable – Keep Fire Away" warning sign and locking handle. For more info, visit DickBlick.com. FOB Factory. See page 648 for details.

NUMBER	SIZE	EACH
AF49201-4012	C 35"H x 23"W x 18"D	\$1030.00
AF49201-4022	D 35"H x 35"W x 22"D	1563.00
AF49201-4045	E 65"H x 43"W x 18"D	2549.00



Justrite' Oily Materials Waste Can

Essential protection wherever solvent or oil cloths, paint rags, and similar hazardous materials are used. A ventilated bottom enables air circulation to disperse heat, preventing spontaneous combustion. The self-closing cover is made of heavy terne plate (tin and lead) and operates by hand or foot pedal. Cover opens to 60° angle and closes automatically. FOB Factory. See page 648 for details.

NUMBER	SIZE	EACH	3/EA
AF35205-1006	6 Gallon	\$118.46	\$106.62
AF35205-1010	10 Gallon	172.70	155.44

F Black Hycar Bib Apron

The apron of choice for studios and classrooms, Hycar resists oils and alkalis, as well as mediums, most acids, and solvents. It's lightweight while providing superior protection — and comfortable too! 45" long for maximum coverage, with nylon ties at the neck and waist. 45"L x 35"W.

NUMBER	EACH	6/EA
A04987-2050	\$37.13	\$33.41

G Disposable Aprons

Lightweight, comfortable polyethylene aprons protect clothing from ink splatters and other messy jobs. Full bib style. 50"L x 32"W. Package of 100.

NUMBER	EACH	10/EA
A32912-1000	\$31.65	\$28.48

H Vinyl Apron

This practical, 6 mil thick polyvinyl apron protects clothes from many common acids, alkalis, solvents, oils, grease, and paints. It has a long yoke neck with long waist ties. Light blue and transparent. 45"L x 35"W.

NUMBER	EACH	12/EA
A04981-5010	\$7.27	\$6.54



Austin Air HealthMate™ Air Cleaner

The HealthMate filters out 99.97% of irritating air particles as well as smoke, gases, and odors, including those caused by most studio solvents. Its HEPA filter cleans a 1,500 sq ft space twice hourly. Features a 360° air intake, 3-speed operation, durable steel construction, and easy-roll casters. The only cleaning required is periodic vacuuming of the outer screen. Measures 23"H x 14"W x 14"D. Weighs 45 lb. FOB Factory. See page 648 for details.

NUMBER	COLOR	EACH
AF52970-2000	Black	\$719.00
AF52970-8900	Sandstone	719.00



Allerair™ Air Purifiers

Allerair indoor air purifiers feature a powerful, four-stage filtration system that uses 15 lb of activated carbon and a HEPA filter to eliminate airborne particles, chemicals, gases, and odors. Each purifier cleans 1,500 sq ft of space and includes a 3-speed, 400 CFM motor and two anti-microbial filters. The cylindrical shape maximizes airflow, while casters provide easy maneuverability. Choose the model that best fits your needs. The 5000 Exec is an all-purpose purifier that's perfect for pastelists and painters because it filters dust and other general particulates from the air. The 5000 VOC removes volatile organic compounds such as turpentine and mineral spirits. The purifiers measure 20-1/2"H x 15"Dia and weigh 39 lb. FOB Factory. See page 648 for details.

NUMBER	DESCRIPTION	EACH
AF52833-2050	5000 Exec, Black	\$763.00
AF52833-8920	5000 Exec, Sandstone	763.00
AF52833-1040	5000 Exec, White	763.00
AF52833-2051	5000 VOC, Black	873.00
AF52833-8921	5000 VOC, Sandstone	873.00
AF52833-1041	5000 VOC, White	873.00

Replacement Filters — FOB Factory. See page 648 for details.

NUMBER	DESCRIPTION	EACH
AF52833-1004	Pre-Filter 4-Pack	\$66.59
AF52833-1002	Exec Carbon Filter	187.80
AF52833-1003	VOC Carbon Filter	288.27

Xyron® Pro XM1255 Laminator
Three solutions in one easy-to-use machine! This laminator makes applying adhesive or laminate to storyboards, mockups, signs, displays, short-run labels, or comps fast and easy — without heat or electricity. Xyron's aggressive adhesives, coupled with the XM1255's high-pressure rollers, improves both the transfer and bonding quality, while drop-in cartridges allow quick, easy adhesive changes and even, edge-to-edge application. The Pro XM1255 accommodates documents up to 0.125" thick and 11-3/4" wide. Weighs 14.75 lb. FOB Factory. See page 648 for details.



NUMBER	DESCRIPTION	EACH
AF23118-1012	12" Laminator	\$439.00
A23246-1060	Permanent High-Tack Adhesive, 100 ft	121.50
A23246-1070	Permanent Standard Adhesive, 100 ft	121.50
A23246-1080	Repositionable Adhesive, 100 ft	144.07
A23246-1090	Two-Sided Standard-Use Laminate, 100 ft	121.65



Flash Pro, 9-1/2"

Black & Decker® Flash™ & Flash™ Pro Thermal Laminators

Protect and preserve important papers in a flash with Black & Decker Flash Laminators. Boasting exclusive Flash Heat Technology, they warm up quickly and get the job done faster. All models feature a digital control system with audible alerts, three temperature settings, and an integrated corner punch function.

Flash Pro Thermal Laminator — High-volume, professional-quality model heats fully in just 60 seconds and works at a speed of 48" per minute — seven times faster than most laminators on the market. Choose from two sizes.

NUMBER	DESCRIPTION	EACH
A24522-2029	9-1/2" Wide	\$202.69
A24522-2021	12-1/2" Wide	270.65

Black & Decker TimeShield™ Thermal Laminating Pouches

For use with all Black & Decker Flash Laminators. Enhanced with UV protection. Glossy finish is guaranteed to enhance clarity.

NUMBER	DESCRIPTION	EACH
A24523-1025	4" x 6", Pkg of 25	\$5.95
A24523-1125	5" x 7", Pkg of 25	6.41
A24523-1425	8-1/2" x 11", Pkg of 25	21.95

For more laminators, visit DickBlick.com.



Fujipla® 25" Roller Laminator

Laminate art projects, posters, documents, and more with this easy-to-operate, heavy-duty laminator. Roller separation lever allows for easy film threading and eliminates flat spots on the rollers that occur after extended downtime. Features a reverse switch, five-minute warm-up time, and a temperature control setting that allows for standard high-melt film and lower melt high-clarity film. Full one-year warranty. Weighs 75 lb. Use with Dry-Lam laminating film rolls (sold at right). Truck Shipment and FOB Factory. See page 648 for details.

NUMBER	EACH
AF23133-1025	\$1979.00



Grafix® Stencil Film

This tough, non-tearing polyester stencil film lets you create or copy designs and turn them instantly into templates. Simply draw or trace your design with a pen, cut it out, and you're ready to stencil. Cuts easily with scissors, craft knife, die-cut machine, or stencil cutter. Can be used over and over without tearing or losing its ability to lay flat. Package of four 9" x 12" sheets in light blue or matte finish.

NUMBER	DESCRIPTION	EACH	12/EA
A23204-5007	Blue Film, .007"	\$7.14	\$6.43
A23204-0052	Matte Film, .005"	7.14	6.43

Dry-Lam® Film

For laminating documents, posters, menus, art projects, teaching aids, and more. 3 mil EVA film with co-polymer adhesives means faster laminating, better adhesion to most surfaces. Lower melting temperature (230°–250°F) and crystal-clear finish are ideal for laminating inkjet prints. 1.5 mil Standard film is a general-purpose, economical choice for schools and businesses.

NUMBER	DESCRIPTION	EACH	12/EA
A23240-1500	Standard, 1.5 mil, 25"W x 500 ft	\$55.10	\$49.59
A23240-1250	EVA, 3 mil, 25"W x 250 ft	68.33	61.49



A–B Grafix® Laminating Film

A transparent, tear-resistant, permanent adhesive film that's quick and easy to use: just peel and apply. Professional-quality, with no mess or equipment required. The lightweight film performs the same as the heavyweight, but is thinner and more flexible.

A Heavyweight Film — Package of three 9" x 12" sheets.

NUMBER	EACH	12/EA
A23204-0051	\$7.14	\$6.43

B Lightweight Film — Package of four 9" x 12" sheets.

NUMBER	EACH	12/EA
A23204-0021	\$7.14	\$6.43

Grafix® Double Tack Mounting Film

This archival, acid-free material has a twin coating of permanent adhesive on two sides of thin film, sandwiched between two heavy release papers. Lift up one of the release sheets, apply the sticky side to the subject, and remove the other release paper. Mount photos, prints, drawings, crafts, fabric, wood, metal, and ceramics. Requires no moisture, glue, heat, or activator. Save by buying large sheets and then cutting them to the size you need.

NUMBER	DESCRIPTION	EACH	4/EA
A23205-1003	9" x 12" Sheets, Pkg of 3	\$7.14	\$6.43
A23205-1009	18" x 24" Sheet	6.60	5.94
A23205-1005	24" x 36" Sheet	12.18	10.96

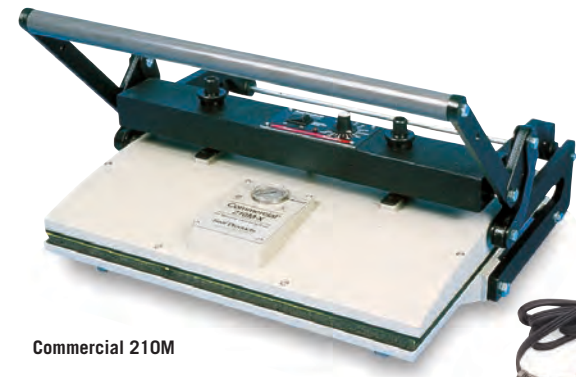

Commercial 210M

Expression® Dry Mount Presses

These presses are simple, easy-to-use tools that can be used with a variety of materials to dry mount, laminate, or reinforce all types of photographs and artwork. Plug into any 115V AC outlet. Solid state, adjustable thermostat for setting exact temperature from 150° to 350°F. Heater system reaches operational temperature quickly; pilot light indicates when it is ready. Flashing signal ticks off the seconds. Durable cantilevers for the right pressure every time. Free-floating platen permits sliding work through the back as well as side-to-side. Three-wire heavy-duty cord, on-off switch, UL listed. FOB Factory. See page 648 for details.

Commercial 210M — This popular press has an 18-1/2" x 23" platen and takes work up to 36" wide and any length in sections. Equipped with thermometer for accurate temperature readout. 1300 watts, 11.3 amps.

NUMBER	EACH
AF23102-0000	\$2631.00

Tacking Iron — Use to tack tissue materials into position on back of artwork to prevent shifting before processing. Pre-set, self-regulating temperature control for safety and long life. Non-stick, coated base.

NUMBER	EACH
A23103-0000	\$96.99



Tacking Iron

Expression® RagMount Dry Adhesive

Developed for dry-mounting digital prints on fine art paper, RagMount is a breathable, permanent, 100% cotton tissue with a pH-neutral, non-yellowing, low-melt adhesive that adheres to a variety of surfaces. Great for giclée.

NUMBER	SIZE	EACH	6/EA
A23404-2451	24-1/2"W x 150 ft	\$236.25	\$212.63
A23404-4051	40-1/2"W x 150 ft	406.00	366.00
A23404-4853	48-1/2"W x 300 ft	779.00	700.00
A23404-1012	8-1/2" x 11"	20.85	18.76
A23404-1007	11" x 17"	39.51	35.55
A23404-1008	16" x 20"	70.23	63.19

NUMBER	SIZE	EACH	6/EA
A23404-1012	8-1/2" x 11"	\$20.85	\$18.76
A23404-1007	11" x 17"	39.51	35.55
A23404-1008	16" x 20"	70.23	63.19

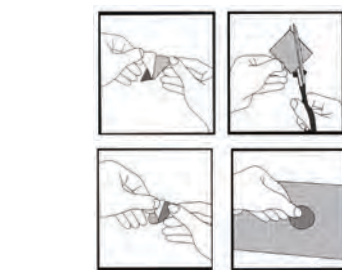

Therm-O-Web® Peel n Stick™ Double-Sided Adhesive Sheets

Create an instant bond on paper, fabric, metal, and more. Ideal for scrapbooks or anywhere a strong, permanent bond is required. Package contains four double-sided 5-1/2" x 8-3/4" sheets that can be trimmed to fit.

NUMBER	EACH	12/EA
A24132-3155	\$4.06	\$3.65



C Adhesive Glue Dots™

Glue Dots bond instantly and won't damage wall paint. They're completely non-toxic, acid-free, and so convenient you'll wonder how you lived without them. Three diameters available, and Pop-Up Dots add 1/8" height.

NUMBER	DESCRIPTION	EACH	12/EA
A23841-1010	Craft, Box of 200	\$4.39	\$3.95
A23841-1020	Mini, Box of 300	4.39	3.95
A23841-1030	Pop-Up, Box of 75	4.39	3.95
A23841-1040	Memory Book, Box of 300	5.50	4.95
A23875-1200	Removable, Box of 200	4.39	3.95
A23841-1050	Craft, Economy Box of 2,500	38.57	34.71

D Therm-O-Web® Adhesive Mounting Squares

These acid-free adhesive mounting squares are a great way to attach photos, paper, and other memorabilia to your projects in the classroom or at home. The box contains 500 white, double-sided, 1/2" squares.

NUMBER	EACH	12/EA
A24132-1500	\$3.85	\$3.47



E Grafix® Artist-tac™ Adhesive Sheets

For easy, accurate mounting of photos, paper, cardstock, plastic, and more. Goes right to the edge but won't bleed. Repositionable until burnished, permanent afterwards. No mess, odor, bumps, waste, or spray hazard. Acid-free. 25 sheets per package.

NUMBER	SIZE	EACH	12/EA
A29800-1059	5-1/2" x 9"	\$15.11	\$13.60
A29800-1011	8-1/2" x 11"	25.56	22.99
A29800-1017	11" x 17"	38.35	34.51

F Removable Mounting Tabs

Replace your tacks, tape, magnets, and staples with these removable mounting tabs. They hold tightly, yet remove easily with no residue. Mount artwork, posters, signs, and more — great for the classroom! 1/2" x 1/2".

NUMBER	DESCRIPTION	EACH	6/EA
A23005-1064	Pkg of 64	\$2.17	\$1.95
A23005-1009	Pkg of 160	4.22	3.79
A23005-1109	Pkg of 480	8.99	8.09



A Elmer's® Spray Adhesive
For a temporary or permanent bond on paper, wood, fabrics, leather, cork, plastic, and more.

NUMBER	SIZE	EACH	6/EA
A23704-1000	11 oz (311 g)	\$6.52	\$5.86

B Aleene's® Repositionable Tacky Spray
This spray adhesive is made with a unique formula that allows it to stick and re-stick to surfaces without leaving residue behind. Use it on lightweight materials that will need to be moved later. Doesn't bleed through, stain, or wrinkle most materials. Dries clear.

NUMBER	SIZE	EACH	6/EA
A23955-1010	10 oz (283 g)	\$13.21	\$11.88

C Elmer's® Extra Strong Spray Adhesive
A strong, water-resistant adhesive for a permanent or temporary bond on photos, wood, glass, fabric, and more. Will not swell or warp. Resists bleed-through.

NUMBER	SIZE	EACH	12/EA
A23720-1350	13.5 oz (333 g)	\$18.98	\$17.08

D Krylon® Low Odor Clear Finish
Formulated with true latex technology, Krylon Low Odor Clear Finish provides the same quality as traditional Krylon coatings. 11 oz (325 ml) cans.

NUMBER	DESCRIPTION	EACH	12/EA
A23710-1001	Gloss	\$10.17	\$9.16
A23710-2001	Matte	10.17	9.16

E Krylon® Spray Adhesive
Strong and permanent, with an extended open tack time, this all-purpose adhesive offers smooth, non-wrinkling adhesion for a variety of lightweight bonding projects. Dries clear with no bleed-through. Archival, acid-free, and non-yellowing.

NUMBER	SIZE	EACH	12/EA
A23715-1011	11 oz (312 g)	\$10.98	\$9.88

F Krylon® Easy-Tack™ Repositionable Spray Adhesive
Provides a transparent, repositionable bond on most lightweight materials. May be adjusted, removed, and reapplied and provides long-lasting tack with no residue, wrinkles, or curling. It's also low-odor, non-staining, and has a 2" wide spray pattern. Acid-free and archival.

NUMBER	SIZE	EACH	12/EA
A23717-1001	10.25 oz (290 g)	\$11.19	\$10.08

G Blair® Artist's Mounting Adhesive
New clear formula has fast tack for permanent or repositionable bonds. For paper, cardboard, illustration/mat board, wood, glass, foil, Mylar, foam board, acetate, and fabric.

NUMBER	SIZE	EACH	6/EA
A23703-1004	11 oz (312 g)	\$12.99	\$11.73

H 3M® Spray Mount™
Bonds to practically any lightweight material instantly, yet allows work to be lifted and repositioned. Requires only one surface application. Does not yellow, get brittle, or flake.

NUMBER	SIZE	EACH	12/EA
A23706-1106	4.4 oz (125 g)	\$9.37	\$8.43
A23706-1105	10.25 oz (290 g)	19.98	18.69

I 3M® Photo Mount™
A strong, clear, non-staining, professional-grade adhesive for mounting all black-and-white and color photographs. Apply to one or both surfaces. Bond is immediate, very strong, and permanent.

NUMBER	SIZE	EACH	12/EA
A23707-1006	4.2 oz (119 g)	\$10.09	\$9.08
A23707-1005	10.3 oz (292 g)	22.85	20.56

J 3M® Super 77
Multi-purpose spray adhesive with high coverage and high tack. Use for bonding lightweight materials, felt, plastics, foam, metal sheeting, fiberglass insulation, and paper products. Not recommended for vinyls or Styrofoam™.

NUMBER	SIZE	EACH	12/EA
A23706-1016	4.4 oz (125 g)	\$9.05	\$8.15
A23706-1005	7 oz (198 g)	12.31	11.08
A23706-1006	13.6 oz (386 g)	20.09	18.07

K Gorilla® Spray Adhesive
A multi-purpose spray adhesive with a strong bond that's repositionable yet dries permanent. Its clear formula doesn't yellow over time, and it's water-resistant for indoor and outdoor use.

NUMBER	SIZE	EACH	6/EA
A23938-1004	4 oz (113 g)	\$7.15	\$6.43
A23938-1001	11 oz (311 g)	9.91	8.91

L E6000® Spray Adhesive
Strong, flexible, and easy to use. This multi-purpose, photo-safe adhesive resists bleed-through and yellowing. No VOCs, harsh chemicals, or propellants, so it's odorless and free of toxic fumes. Dries translucent and cleans up with water.

NUMBER	SIZE	EACH	12/EA
A23962-1005	8 oz (236.5 ml)	\$13.28	\$11.95

BLICK® tapes

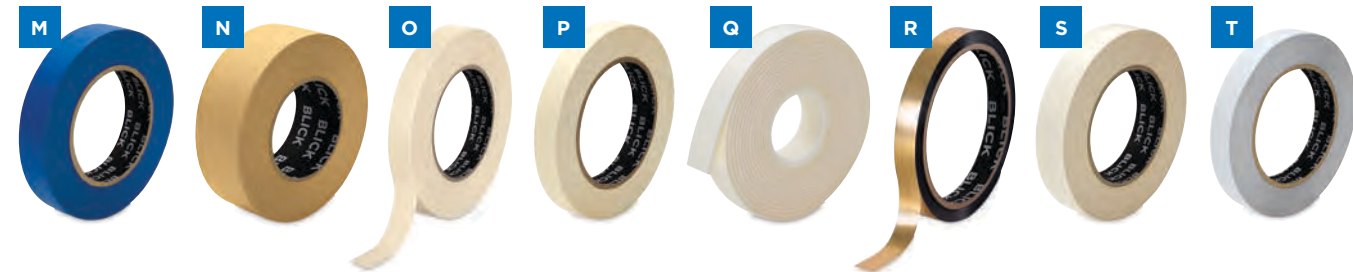

M Blick® Painter's Tape
Our blue masking tape is engineered for the most demanding jobs. Use it for professional painting or to mask delicate surfaces.

NUMBER	SIZE	EACH	12/EA
A24146-3460	3/4" x 60 yd	\$7.15	\$6.43
A24146-1060	1" x 60 yd	8.69	7.82
A24146-2060	2" x 60 yd	12.79	11.51

N Blick® Carton Sealing Tape
A flat-back paper tape with an aggressive synthetic rubber adhesive. Can be used for packaging as well as silk screening, picture framing, splicing, and tabbing.

NUMBER	SIZE	EACH	12/EA
A24142-2060	2" x 60 yd	\$15.81	\$14.23

O Blick® Acid-Free Masking Tape
An acid-free version of our exclusive masking tape. Adheres well and removes cleanly.

NUMBER	SIZE	EACH	12/EA
A24149-1134	3/4" x 60 yd	\$6.98	\$6.29
A24149-1101	1" x 60 yd	8.95	\$8.05

P Blick® Drafting Tape
A thin, flexible tape designed to hold drawings, blueprints, or tracings to drawing boards. Adheres well and removes easily without residue or damage.

NUMBER	SIZE	EACH	12/EA
A24153-1005	1/2" x 60 yd	\$7.21	\$6.49
A24153-1075	3/4" x 60 yd	8.66	\$7.79
A24153-1001	1" x 60 yd	11.95	\$10.75

Q Blick® Foam Tape
1/16" thick foam tape developed for general purpose bonding applications. It is coated on both sides with an aggressive, permanent, rubber-based adhesive.

NUMBER	SIZE	EACH	12/EA
A24154-1012	1/2" x 75"	\$5.15	\$4.62

R Blick® Metallic Tape
Use this premium-grade, metallic tape to color-code, decorate, or add sparkling highlights to craft projects. Made of metalized polyester film.

NUMBER	COLOR	SIZE	EACH	12/EA
A24174-9016	Gold	1/2" x 36 yd	\$11.61	\$10.44
A24174-9336	Silver	1/2" x 36 yd	11.61	10.44

S Blick® Double-Coated Paper Tape
Ideal for mounting, bonding, splicing, and laminating, with high tack, good tensile strength, and moderate shear properties. This tape works well on plastic and metal as well as paper. Like all Blick brand products, it's also a great value.

NUMBER	SIZE	EACH	12/EA
A12794-1036	1" x 36 yd	\$13.77	\$12.39

T Blick® Double-Sided Tape
A clear, permanent, polyester tape that holds firmly to any smooth surface. Excellent for framing, it is also ideal for mounting films (especially repro films) where lack of space prevents the use of normal adhesive tape.

NUMBER	SIZE	EACH	12/EA
A24147-5036	1/2" x 36 yd	\$8.47	\$7.62
A24147-3436	3/4" x 36 yd	11.30	10.17
A24147-1036	1" x 36 yd	13.67	12.30



U Blick® Artist Tape
Use this tape for art projects, crafts, color coding, labeling, and more. Its repositionable adhesive makes it easy to pull up. Strong, pH-neutral, and great for writing on!

NUMBER	COLOR	SIZE	EACH	12/EA
A24143-2060	Black	1/2" x 60 yd	\$6.38	\$5.74
A24152-2060	Black	1" x 60 yd	10.55	9.49
A24143-5060	Blue	1/2" x 60 yd	6.38	5.74
A24152-5060	Blue	1" x 60 yd	10.55	9.49
A24143-7270	Fl. Green	1/2" x 60 yd	8.31	7.48
A24143-7271	Fl. Green	1" x 60 yd	15.28	13.73
A24143-7274	Fl. Green	3/4" x 60 yd	9.90	8.91
A24143-3720	Fl. Pink	1/2" x 60 yd	8.31	7.48
A24143-3724	Fl. Pink	3/4" x 60 yd	9.90	8.91
A24143-3721	Fl. Pink	1" x 60 yd	15.28	13.73
A24143-4220	Fl. Yellow	1/2" x 60 yd	8.31	7.48

NUMBER	COLOR	SIZE	EACH	12/EA
A24143-4224	Fl. Yellow	3/4" x 60 yd	\$9.90	\$8.91
A24143-4221	Fl. Yellow	1" x 60 yd	15.28	13.73
A24143-7060	Green	1/2" x 60 yd	6.38	5.74
A24152-7060	Green	1" x 60 yd	10.55	9.49
A24143-4514	Orange	3/4" x 60 yd	9.90	8.91
A24143-3060	Red	1/2" x 60 yd	6.38	5.74
A24152-3060	Red	1" x 60 yd	10.55	9.49
A24143-1024	White	1/4" x 60 yd	4.65	4.19
A24143-1260	White	1/2" x 60 yd	6.65	5.99
A24143-1028	White	3/8" x 60 yd	6.65	5.99
A24143-3460	White	3/4" x 60 yd	9.06	8.15
A24152-1060	White	1" x 60 yd	10.05	9.05
A24143-1021	White	1-1/2" x 60 yd	18.65	16.77
A24143-1022	White	2" x 60 yd	23.31	20.97
A24143-4060	Yellow	1/2" x 60 yd	6.38	5.74
A24152-4060	Yellow	1" x 60 yd	10.55	9.49



V Blick® Masking Tape
Count on Blick Masking Tape to stick quick, hold fast (even at high temperatures), remove cleanly, and save you money. 100% satisfaction guaranteed.

NUMBER	COLOR	SIZE	EACH	12/EA
A24149-2005	Black	1/2" x 60 yd	\$5.25	\$4.73
A24149-2075	Black	3/4" x 60 yd	6.99	6.29
A24149-2001	Black	1" x 60 yd	8.69	7.82
A24149-1018	Natural	1/8" x 60 yd	2.15	1.93
A24149-1014	Natural	1/4" x 60 yd	2.25	1.99
A24149-1012	Natural	1/2" x 60 yd	2.70	2.43
A24149-1034	Natural	3/4" x 60 yd	2.92	2.61
A24149-1001	Natural	1" x 60 yd	3.82	3.43
A24149-1002	Natural	2" x 60 yd	7.26	6.53
A24149-1003	Natural	3" x 60 yd	9.93	8.93

W Blick® Gaffer Tape
Versatile cloth tape is a great staple for every artist's studio. The rubber-based adhesive offers good adhesion, even on irregular surfaces. Weather- and abrasion-resistant, yet easily tearable by hand.

NUMBER	COLOR	SIZE	EACH	12/EA
A24148-2001	Black	1" x 30 yd	\$8.80	\$7.92
A24148-2002	Black	2" x 30 yd	16.15	14.53
A24148-2003	Black	3" x 30 yd	25.54	22.98
A24148-2723	Green	1" x 30 yd	13.77	12.39
A24148-4503	Orange	1" x 30 yd	13.77	12.39
A24148-3723	Pink	1" x 30 yd	13.77	12.39
A24148-1021	White	1" x 30 yd	11.88	10.69
A24148-1022	White	2" x 30 yd	25.99	23.39



A Masking Tape

This tape is extra-strong, extra-flexible, and sticks instantly. It's also a great value! 3" core.

NUMBER	SIZE	EACH	12/EA
A24126-1012	1/2" x 60 yd	\$2.08	\$1.82
A24126-1018	3/4" x 60 yd	3.07	2.77
A24126-1024	1" x 60 yd	3.22	2.90
A24126-1036	1-1/2" x 60 yd	3.38	2.98
A24126-1048	2" x 60 yd	5.99	5.33
A24126-1072	3" x 60 yd	7.83	6.98

B Kraft Paper Tape

Traditional gummed, 60 lb packaging tape creates a strong, long-lasting seal on boxes and cartons. Moistens to use. 1-1/2" core.

NUMBER	SIZE	EACH	10/EA
A24118-1002	2" x 600 ft	\$9.15	\$8.23
A24118-1003	3" x 600 ft	14.09	12.68

C Artist Tape

Use this tape for temporarily holding artwork to drawing boards. The smooth white surface is great for writing on, making it ideal for labeling purposes. 3" core.

NUMBER	SIZE	EACH	12/EA
A24124-1012	1/2" x 60 yd	\$6.93	\$6.23
A24124-1034	3/4" x 60 yd	9.35	8.41
A24124-1001	1" x 60 yd	12.56	11.30

D 3M™ Tartan™ Masking Tape

General-purpose masking tape designed for non-critical and utility applications. Should be removed within four hours and should not be applied to wallpaper, unpainted wallboard, or ceiling tile.

NUMBER	SIZE	EACH	12/EA
A24113-1070	0.70" x 60 yd	\$2.25	\$1.65
A24113-1094	0.94" x 60 yd	2.88	2.12
A24113-1141	1.41" x 60 yd	4.25	3.12
A24113-1188	1.88" x 60 yd	5.59	4.10

E Economy Painter's Tape

This blue painter's masking tape features an acrylic adhesive that works well on painted walls, woodwork, and other surfaces. An economical alternative to name-brand tapes.

NUMBER	SIZE	EACH	12/EA
A24119-5034	3/4" x 60 yd	\$7.46	\$6.71
A24119-5001	1" x 60 yd	9.39	8.45
A24119-5112	1-1/2" x 60 yd	13.85	12.46

F 3M™ Highland™ Transparent Tape

All-purpose transparent tape, economical to use in the classroom, home, and office.

36 Yard Roll on a 1" Core

NUMBER	WIDTH	EACH	12/EA
A23017-0050	1/2"	\$1.41	\$1.28
A23017-1000	3/4"	2.03	1.85

72 Yard Roll on a 3" Core

NUMBER	WIDTH	EACH	12/EA
A23017-1100	3/4"	\$9.51	\$8.67

G Scotch™ #845 Book Tape

Durable, conformable, crystal-clear tape for repairing, reinforcing, protecting bound edges and surfaces of books, magazines, and more. Also for hinging and laminating. Very strong bond. Will not crack or dry out. 3" core.

NUMBER	SIZE	EACH	6/EA
A23021-1015	1-1/2" x 15 yd	\$7.91	\$7.38
A23021-1002	2" x 15 yd	10.75	10.03
A23021-1003	3" x 15 yd	16.38	15.28
A23021-1004	4" x 15 yd	21.87	20.40

H Scotch™ #665 Double-Coated Transparent Tape

Linerless plastic film with adhesive on both sides. Long-lasting adhesive sticks and holds instantly. Thin, non-bulky, for splicing and mounting. 3" core.

NUMBER	SIZE	EACH	12/EA
A23016-0050	1/2" x 36 yd	\$10.39	\$9.52

I Scotch™ Heavy-Duty Tape Dispensers

These high-impact plastic dispensers have weighted bases and foam rubber bottoms to protect counter surfaces. Almond beige color. Single dispenser accommodates one tape roll up to 1" wide. Double dispenser accommodates two 1" wide tape rolls or one 2" wide tape roll.

NUMBER	DESCRIPTION	EACH
A23305-1002	Double	\$164.07
A23305-0000	Single	94.03

J Scotch™ Adhesive Transfer Tape ATG 700 Dispenser

Lightweight dispenser rolls out strips of double-sided, clear adhesive while winding the kraft paper liner inside. Ideal for mounting and framing. Use with the tapes listed below.

NUMBER	EACH	6/EA
A23308-1700	\$102.85	\$92.60

#924 Transfer Tape

NUMBER	SIZE	EACH	48/EA
A23020-0050	1/2" x 36 yd	\$10.68	\$9.61
A23020-1000	3/4" x 36 yd	13.19	11.88

K Adhesive Transfer Tapes and ATG Dispenser

Use these photo-safe transfer tapes for all your graphic art needs.

Dispenser — Accepts 1/4"W to 3/4"W tapes on 1" core, with a roll length of up to 60 yards.

NUMBER	EACH	6/EA
A23322-4860	\$73.55	\$66.19

ATG 160 — Ideal for signage, picture framing, and general crafts. 1.6 mm thickness.

NUMBER	SIZE	EACH	6/EA
A24165-1612	1/2" x 36 yd	\$5.30	\$4.76
A24165-1634	3/4" x 36 yd	7.82	7.03

ATG 200 Tape — The professional's choice for photo mounting, splicing, poster mounting, and picture framing. 2 mm thickness.

NUMBER	SIZE	EACH	6/EA
A24165-2012	1/2" x 36 yd	\$6.60	\$5.93
A24165-2034	3/4" x 36 yd	10.96	9.85

L Scotch™ Super Strength Packaging Tape

Packaging tape that's strong enough to hold together your heaviest packages. The dispenser ensures the tape unwinds easily and does not fall back on the roll. Perfect for moving and mailing packages.

NUMBER	SIZE	EACH	12/EA
A23055-1000	1.8" x 27.7 yd	\$5.36	\$4.83
A23055-1002	1.88" x 38.2 yd	8.58	7.72
A23055-0000	2" x 22.2 yd	4.24	3.80

Roll NUMBER	SIZE	EACH	12/EA
A23055-1003	1.88" x 54.6 yd	\$7.81	\$7.04



ShurTech™ Duck Tape™ Prints

Fun, multicolored prints make for eye-catching craft projects. 1.88"W x 10 yd rolls.

NUMBER	COLOR	EACH	6/EA
A34140-4030	Cacti	\$6.98	\$6.30
A34140-2020	Checker	6.98	6.30
A34140-5010	Galaxy	6.98	6.30
A34140-3060	Honeycomb	6.98	6.30
A34140-3040	Irregular Dot	6.98	6.30
A34140-3070	Marble	6.98	6.30
A34140-3090	Mermaid	6.98	6.30
A34140-3080	Neon Floral	6.98	6.30
A34140-1060	Tribal	6.98	6.30
A34140-3010	Unicorns	6.98	6.30



ShurTech™ Color Duck Tape™

Building on the strength and adhesive qualities of original Duck Tape, these colorful tapes add fun and style to craft projects, repairs, and even clothing! 1-3/4"W x 20 yd rolls.

NUMBER	COLOR	EACH	12/EA
A34139-5160	Aqua	\$7.30	\$6.59
A34139-8140	Beige	7.30	6.59
A34139-2050	Black	7.30	6.59
A34139-5380	Blue Ocean	7.30	6.59
A34139-8000	Brown	7.30	6.59
A34139-2610	Dove Grey	7.30	6.59
A34139-7271	Flo Citrus	7.30	6.59
A34139-6410	Fluor Lilac	7.30	6.59
A34139-5560	Frozen Blue	7.30	6.59
A34139-7030	Green	7.30	6.59
A34139-5010	Light Blue	7.30	6.59
A34138-9020	Metallic Gold	7.30	6.59
A34139-5630	Purple	7.30	6.59
A34139-2980	Red	7.30	6.59
A34138-2410	Silver Coin	7.30	6.59
A34139-8170	Terracotta	7.30	6.59
A34139-1040	White	7.30	6.59
A34139-4540	Yellow	7.30	6.59
A34139-4700	You're a Sage	7.30	6.59



ShurTech™ Duck Washi Tape

A fun, low-tack paper tape featuring dynamic, colorful patterns inspired by traditional Japanese washi papers. Easy to tear and repositionable, it's ideal for paper crafts, décor items, attention-grabbing notes, and much more.

NUMBER	COLOR	EACH	12/EA
A34178-9511	Metallic Copper	\$4.89	\$4.40
A34178-9021	Metallic Gold	4.89	4.40
A34178-9611	Metallic Herringbone	4.89	4.40
A34178-4411	Metallic Honeycomb	4.89	4.40
A34178-9321	Metallic Silver	4.89	4.40
A34178-9331	Silver Stripe	4.89	4.40

NEW! QUICK QUOTE.
Create a quote on demand at DickBlick.com



M Mavalus™ Tape

Made with superior adhesives, Mavalus Tape sticks to surfaces where most tapes fail, including brick and damp cinder block. It's removable in most cases, with no sticky residue. Rolls are 27 ft long.

NUMBER	COLOR	WIDTH	EACH	10/EA
A12766-4861	Blue	1"	\$4.73	\$4.25
A12766-7031	Green	1"	4.73	4.25
A12766-2981	Red	1"	4.73	4.25
A12766-1041	White	1"	4.73	4.25
A12766-4021	Yellow	1"	4.73	4.25

Numbered Measuring Tape

NUMBER	WIDTH	EACH	10/EA
A12766-1001	1"	\$4.73	\$4.25



N Colored Masking Tape

Extra-strong, flexible, creped masking tape in bright colors for decorating, packaging, repairs. 3/4"W x 60 yard rolls on a 3" core.

NUMBER	COLOR	EACH	12/EA
A23008-2075	Black	\$5.69	\$5.13
A23008-7000	Green	5.69	5.13
A23008-3000	Red	5.69	5.13
A23008-1060	White	5.69	5.13
A23008-4000	Yellow	5.69	5.13



O ShurTech™ Duck Texture Tape

The same durable ShurTech Duck Tape — with trendy patterns you can feel. Personalize school and office supplies or craft a next-level Duck Tape prom dress. Tear it by hand and adhere it to a variety of surfaces, including wood, vinyl, plastic, leather, and other ShurTech Duck Tapes. Rolls are self-wound without a paper backing.

NUMBER	COLOR	EACH	12/EA
A24483-1003	Cobalt Stripe	\$5.42	\$4.89
A24483-1005	Fuchsia Wave	5.42	4.89
A24483-1002	Purple Dot	5.42	4.89
A24483-1001	Turquoise Dot	5.42	4.89



P ShurTech™ Duck Mirror Crafting Tape

Make your craft projects shine! This tape is perfect for scrapbooking, decorating, and adding pizzazz to Duck Tape prom outfits. It has no paper backing and can be easily cut with scissors or an electronic cutting machine. It sticks to all kinds of surfaces, such as wood, plastic, metal, and other ShurTech Duck Tapes.

NUMBER	COLOR	WIDTH	EACH	12/EA
A24484-9017	Gold Mirror	3/4"	\$4.51	\$3.99
A24484-9337	Silver Mirror	3/4"	4.51	3.99
A24484-1027	White Mirror	3/4"	4.51	3.99
A24484-9011	Gold Mirror	1.88"	9.67	8.69
A24484-9331	Silver Mirror	1.88"	9.67	8.69
A24484-1021	White Mirror	1.88"	9.67	8.69



Scotch® Wall Safe Tape

Made with unique Post-it brand adhesive technology, this tape sticks well, but can be removed without damaging walls, photos, and art. Safe for most surfaces, including painted drywall, stainless steel, and tile. Refillable dispenser.

NUMBER	EACH	12/EA
A24480-1650	\$4.68	\$4.20



3M® Post-it® Tabs and Flags

Post-it Memo Flags and Tabs make it simple to mark and highlight important information. Draw attention to critical items or use them to index, file, or color-code your work. Great for planners, binders, and file folders, they stick securely and remove cleanly. Write on and reposition the durable tabs as needed.

NUMBER	DESCRIPTION	EACH	24/EA
A24339-1001	3 pk Writable, Bright, 36 Tabs	\$4.64	\$4.18
A24339-1002	5 pk, Bright, 100 Tabs	4.35	3.92
A24339-1003	4 pk, Bright, 40 Tabs	4.33	3.90
A24339-1004	3 pk, Neon, 36 Tabs	4.33	3.90
A24339-1005	3 pk Durable, Primary, 36 Tabs	4.51	4.07



Rio 24 Pack

Canary Yellow



10 packs

3M® Post-it® Super Sticky Notes

Perfectly sticky results with every use. Their unique, extra-sticky adhesive is so strong that they'll stay put on vertical surfaces, like monitors, doors, and walls. Plus, the bright colors ensure they'll get noticed. Colors may vary.

NUMBER	DESCRIPTION	COLOR	SIZE	EACH	6/EA
A24333-1001	3 pk, 45 shts	Miami	3" x 3"	\$3.70	\$3.33
A24333-1005	8 pk, 90 shts	Miami	1-7/8" x 1-7/8"	9.44	8.49
A24333-1006	5 pk, 90 shts	Miami	3" x 3"	10.41	9.36
A24333-1015	Notes Cube, 400 shts	Pink	2" x 2"	3.62	3.25
A24333-1009	3 pk, 45 shts	Rio	3" x 3"	3.79	3.41
A24333-1010	8 pk, 45 shts	Rio	1-7/8" x 1-7/8"	9.44	8.49
A24333-1011	24 pk, 70 shts	Rio	3" x 3"	36.96	33.25
A24333-1012	4 pk, 35 shts	Rio	3" x 3"	4.68	4.21
A24333-1013	10 pk, 90 shts	Rio	3" x 3"	21.53	19.36
A24333-1003	4 pk, 90 shts	Canary Yellow	4" x 4"	10.32	9.28
A24333-1004	4 pk, 45 shts	Miami	4" x 6"	9.44	8.49
A24333-1007	3 pk, 90 shts	Miami	4" x 6"	12.70	11.43
A24333-1008	6 pk, 90 shts	Miami	4" x 4"	18.88	16.98
A24333-1002	4 pk, 45 shts	Rio	4" x 6"	9.44	8.49
A24333-1016	4 pk, 45 shts	Rio	4" x 4"	13.23	11.90



Gorilla™ Tape

This heavy-duty, double-thick adhesive is designed to stick to rough, uneven surfaces, such as wood, stucco, brick, and more. Its all-weather shell and strong, reinforced, tight weave backing contribute to the tape's heft, yet it can still be ripped by hand easily.

NUMBER	COLOR	SIZE	EACH	6/EA
A24137-2501	Black	1" x 30 ft	\$6.15	\$5.54
A24137-1021	White	1.88" x 10 yd	5.81	5.22
A24137-1020	White	1.88" x 30 yd	13.49	12.14

Got a question about a product? Our experts have the answer! Three ways to connect — Live Chat at DickBlick.com, call 800.933.2542, or email info@DickBlick.com.



T-REX Tape® Ferociously Strong Tape™

This tape lives up to its name. Perfect for projects requiring extreme holding power, it can still be easily torn off the roll. It's twice as thick as other duct tapes and has a UV resistant layer. Use for indoor and outdoor projects big and small.

NUMBER	SIZE	EACH	12/EA
A24481-1010	1" x 10 yd	\$6.51	\$5.86
A24481-1012	1.88" x 12 yd	8.85	7.97

RUBBER CEMENTS & ACCESSORIES



A



B



C



D



E



F



G



G

A Beacon™ Artist Quality Rubber Cement

Collage, mount photos, and more. Premium, natural white rubber cement produces superior results with each application. Ideal for classroom, home, and commercial use. Acid-free formula doesn't shrink, curl, or wrinkle paper. Flammable.

NUMBER	SIZE	EACH	12/EA
A23931-1004	4 oz (120 ml)	\$6.60	\$5.94
A23931-1005	8 oz (237 ml)	10.99	9.91
A23931-1006	16 oz (473 ml)	15.41	13.87
A23931-1007	32 oz (946 ml)	23.13	20.82

B Elmer's® Rubber Cement

The ability to reposition work makes this cement ideal for projects that require accurate placement. Spreads easily. 8 oz (237 ml) jar has a cap with a built-in application brush.

NUMBER	SIZE	EACH	12/EA
A23903-1014	4 oz (120 ml)	\$3.15	\$2.84
A23903-1005	8 oz (237 ml) Glass Jar	5.99	5.39
A23903-1007	32 oz (946 ml) Can	17.47	15.72

C Rubber Cement Dispensers

Choose amber glass or white plastic with screw-lock cap. Adjustable brush applicator with airtight sleeve. No evaporation.

Amber Glass		EACH	12/EA
NUMBER	SIZE		
A24907-8135	9 oz (266 ml)	\$12.87	\$11.58
A24907-8130	16 oz (473 ml)	13.86	12.47
White Plastic		EACH	12/EA
NUMBER	SIZE		
A24907-1005	8 oz (237 ml)	\$11.96	\$10.76
A24907-1006	16 oz (473 ml)	12.87	11.58

D Best-Test® Acid-Free Paper Cement

High-quality artist's cement that's crystal-clear, easy to clean, and won't cause paper to wrinkle. Ideal for graphic art use. Includes brush.

NUMBER	SIZE	EACH	12/EA
A23902-1004	4 oz (120 ml)	\$6.57	\$5.91
A23902-1005	8 oz (237 ml)	11.34	10.20
A23855-1006	16 oz (473 ml)	13.99	12.61
A23855-1007	32 oz (946 ml)	22.12	19.90

E Best-Test® One-Coat

Objects can be repositioned again and again, yet rubber cement will remain tacky and hold strong. Acid-free and pressure-sensitive, perfect for commercial and fine art applications.

NUMBER	SIZE	EACH	12/EA
A23812-1005	8 oz (237 ml)	\$11.65	\$10.48
A23812-1007	32 oz (946 ml)	24.47	21.99

F Best-Test® Rubber Cement

Ideal for joining all types of paper! Dries fast and clear for temporary or permanent adhesion, allowing paper to be separated for repositioning. Spreads evenly and smoothly so paper will stay wrinkle-free. Artist-grade. Flammable.

NUMBER	DESCRIPTION	EACH	24/EA
A23713-1014	4 oz (120 ml) Plastic Jar w/brush	\$4.30	\$3.87
A23713-1005	8 oz (236 ml) Glass Jar w/brush	6.39	5.75
A23713-1006	Pint (473 ml)	10.81	9.73
A23713-1007	Quart (946 ml)	16.33	14.70

G Best-Test® Bestine Solvent & Thinner

Used for restoring consistency or removing rubber cement. Flammable.

NUMBER	SIZE	EACH	12/EA
A23902-1006	16 oz (473 ml)	\$15.83	\$14.25
A23712-1007	32 oz (946 ml)	20.33	18.29

PASTES



H Weldbond® Universal Adhesive

Wood, glass, ceramics, porous and non-porous surfaces — Weldbond bonds anything to anything (with the exception of some types of rubber, plastic, and cast metals). It's ideally suited for building architectural models. It dries in just one hour and is transparent when fully bonded. Non-toxic and odorless. Cleans up with water.

NUMBER	SIZE	EACH	12/EA
A23912-1060	2 oz (60 ml)	\$4.84	\$4.35
A23912-1160	5.4 oz (160 ml)	6.17	5.55
A23912-1420	14.2 oz (420 ml)	10.29	9.26
A23912-1003	101 oz (3 Liter)	46.92	42.23



I PlayBox™ Wheat Paste

Playbox Wheat Paste is made from real wheat and contains no preservatives. It's perfect for making papier mâché, or for any project that calls for paper paste. It mixes easily, and is non-toxic and non-staining. Shipped in a powder form, it has a long shelf life when stored dry. Only mix enough paste for the project at hand, since the wet paste will spoil if not used immediately.

NUMBER	SIZE	EACH	6/EA
A24007-1001	1 lb (454 g)	\$4.51	\$4.06
A24007-1003	3 lb (1.4 kg)	11.55	10.40



J Elmer's® Paper Maché Art Paste

Mix with cold water to make a smooth-spreading paste for decoupage, papier mâché, collage, and crafts. Non-toxic, non-staining, and colorless. Package makes four quarts.

NUMBER	SIZE	EACH	12/EA
A24003-1003	2 oz (60 ml)	\$4.21	\$3.79



K Yasutomo® Nori™ Paste

Nori Paste is an excellent paper glue. Use it for collage, egg craft, card making, and scrapbooking. It adheres paper to glass, plastic, and metal and is slow to dry so you can easily reposition. Dries clear, won't stain paper, and washes off easily. The plastic squeeze jar has a snap-on lid with a flat tip for easy application. Acid-free.

NUMBER	DESCRIPTION	EACH	12/EA
A24000-1001	1.84 oz (54 ml) Jar	\$3.55	\$3.19
A24000-1002	10.58 oz (313 ml) Jar	10.99	9.91
A24000-1003	Pkg of 20, 1.84 oz Jars	52.50	47.25

Scotch® #810 Magic™ Transparent Tape

Permanent, sticks easily, nearly disappears on contact — and you can write on it! Won't discolor.

NUMBER	WIDTH	EACH	48/EA
A23012-0050	1/2"	\$3.30	\$2.97
A23012-1000	3/4"	4.37	3.93

72 Yard Roll on a 3" Core

NUMBER	WIDTH	EACH	48/EA
A23012-0051	1/2"	\$5.94	\$5.34
A23012-1100	3/4"	8.12	7.30

Magic Tape in Dispenser, Pkg of 3 — Includes three rolls of 3/4"W x 8.3 yard tape in refillable dispensers.

NUMBER	EACH	48/EA
A23012-1300	\$6.42	\$5.79



A Better Ultimate Adhesive

This multi-purpose glue is strong, durable, and flexible. Plus, it's versatile — use it on wood, stone, glass, paper, and more. It's shock-resistant and weatherproof. The formula is non-toxic, low VOC, and low odor. It has a two-year shelf life and a clog-resistant cap. Dries clear.

NUMBER	DESCRIPTION	EACH	12/EA
A23958-1001	Slow Dry, 2 ml	\$8.81	\$7.93
A23958-1002	Fast Dry, 2 ml	8.81	7.93

C UHU® Max Repair Extreme Adhesive

A strong, flexible, universal adhesive for indoor and outdoor repairs of all kinds. Water-resistant and dishwasher-proof. Max Repair can fill gaps and cracks, and can be painted after curing. It's also resistant to vibrations, shock, and ultraviolet. Solvent-free, dries clear.

NUMBER	SIZE	EACH	12/EA
A23953-1007	0.71 oz (21 ml)	\$6.11	\$5.50

E Gorilla Clear Grip Glue

Provides a waterproof, permanent hold in just seconds. The flexible adhesive dries crystal-clear and bonds metal, glass, fabric, wood, ceramic, rubber, and more. The glue is photo safe and paintable when dry. Made in the USA.

NUMBER	SIZE	EACH	12/EA
A23973-1002	0.2 oz (6 ml) each 4 mini tubes	\$6.60	\$5.94
A23973-1001	3 oz (88 ml) tube	6.60	5.94

F-G Surehold® Plastic Surgery® Super Glue

Formulated to bond plastics more securely, this instant glue "bites" into materials such as acrylic, ABS, EPDM, nylon, fiberglass, phenolic, Plexiglas, polyester, polystyrene, and PVC. Application is precise and controlled, thanks to the patented drip-proof, clog-proof applicator. Gel has a thicker viscosity. 0.11 oz (3 ml) tubes.

NUMBER	DESCRIPTION	EACH	12/EA
A23633-1603	F Glue	\$3.29	\$2.96
A23633-1002	G Gel	2.43	2.18



O E6000® Craft Adhesive

Formulated to meet the high standards of crafters, E6000 is an outstanding adhesive that can be used with glass, metal, wood, and plastic. Its thicker viscosity outperforms typical glue. When fully cured, it bonds tight, clear, and acid-free.

NUMBER	SIZE	EACH	12/EA
A23802-1004	3.7 oz (109 ml)	\$6.60	\$5.64

P E6000® Jewelry & Bead Adhesive

Precise adhesion for bonding stones, beads, and most jewelry metals. The package contains four precision tips. The adhesive has maximum flexibility. It also adheres polymer clay, metals, wood, leather, and more.

NUMBER	SIZE	EACH	12/EA
A23802-1006	1 oz (29.5 ml)	\$6.11	\$5.51

Q E6000® Precision Tip Adhesive

E6000's most popular adhesive formula, with three attachable tips for fine details and better accuracy while gluing. It works well with glass, plastic, tin, vinyl, and more. It's temperature-resistant, photo- and dishwasher-safe, and paintable. The package also includes a precision tip cap.

NUMBER	SIZE	EACH	12/EA
A23802-1001	1 oz (29.5 ml)	\$6.11	\$5.51

R Amazing Goop Craft Glue

Super strong and versatile, with a nozzle tip for little details and small areas. It bonds a variety of materials, including wood, stone, metal, and glass. It's temperature-resistant, so it remains flexible whether in extreme cold or hot climates. The adhesive is waterproof and washer/dryer safe. Dries clear.

NUMBER	SIZE	EACH	12/EA
A23961-1002	2 oz (59 ml)	\$6.11	\$5.51

B Beacon™ Glass, Metal & More™ Adhesive

A powerful premium glue for bonding glass, metal, most plastics, mosaics, jewelry, leather, rubber, concrete, and more. Permanent, UV-resistant, and weather-resistant, it grabs fast, dries clear, never yellows, and stays flexible.

NUMBER	SIZE	EACH	12/EA
A23888-1001	2 oz (60 ml)	\$10.36	\$9.32

D Beacon™ 527 Multi-Use Glue

A strong multipurpose glue that dries fast, clear, and flexible. Great for a wide variety of classroom and household gluing projects. Use for ceramics, wood, gems, paper, shells, glass, tile, cork, and more. Waterproof formula.

NUMBER	SIZE	EACH	12/EA
A23628-1002	2 oz (60 ml)	\$6.73	\$6.05



H-K Gorilla™ Glue

Designed "for the toughest jobs on planet Earth," Gorilla Glue is the go-to product for bonding dissimilar surfaces, both indoors and out, including wood, stone, metal, ceramics, foam, and glass. The precision tip is easy to use and allows you to apply only the amount of glue you want, exactly where you need it.

NUMBER	SIZE	EACH	6/EA
A23629-1002	H 2 oz (60 ml) Regular	\$6.35	\$5.71
A23629-1004	4 oz (120 ml) Regular	10.26	9.23
A23629-1005	8 oz (240 ml) Regular	17.45	15.70
A23629-1009	I Pkg of 4, 0.11 oz (0.5 ml) Singles	6.87	6.19
A23629-2002	J 2 oz (60 ml) Fast Cure	6.35	5.71
A23629-1020	K 0.75 oz (22 ml) Fast Cure Precision Pen	5.29	4.76

L Gorilla™ Wood Glue

Bonds stronger and faster for wood-to-wood applications. It's ideal for use on hardwoods, soft woods, and wood composites. Water, mildew, and solvent-resistant — perfect for both indoor and outdoor use. Non-toxic.

NUMBER	SIZE	EACH	6/EA
A23629-1014	4 oz (118 ml)	\$2.90	\$2.61
A23629-1008	8 oz (237 ml)	4.75	4.28

M Elmer's® Carpenter's Wood Glue

Grabs fast but allows for repositioning, and will not gum up from heat when sanded or sawed. Penetrates wood deeply for a strong bond. Can be painted and stained.

NUMBER	SIZE	EACH	12/EA
A23893-1004	4 oz (120 ml)	\$3.27	\$2.94

N Elmer's® Stainable Wood Glue Max

Contains real wood fibers for superior staining and sanding. For interior and exterior use. Plastic bottle with pull applicator means no clogging or lost caps.

NUMBER	SIZE	EACH	12/EA
A23892-1005	8 oz (237 ml)	\$7.18	\$6.45
A23892-1006	16 oz (473 ml)	10.78	9.70



S-T Gorilla™ Super Glue

The only super glue tough enough to be called Gorilla — made with rubber particles to form an impact-resistant bond that sets in 10–45 seconds, with no need for clamping. Can be used on nearly anything, from wood to plastic, glass, metal, ceramics, and more.

NUMBER	SIZE	EACH	6/EA
A23629-1015	S 0.5 oz (15 ml) Glue	\$5.81	\$5.23
A23629-2015	T 0.5 oz (15 ml) Gel Glue	5.29	4.76
A23629-1032	0.5 oz (15 ml) Gel Glue, 2pk	3.49	3.15

U Gorilla® Super Glue Brush & Nozzle

Easy-to-use glue with precision in mind. Use the precision tip nozzle or fine bristle brush for detailed projects requiring strong, impact-resistant glue. Dries in 10–30 seconds.

NUMBER	SIZE	EACH	6/EA
A23936-1001	.35 oz (10 ml)	\$5.46	\$4.91

V Gorilla™ Epoxy

Easily bonds steel, wood, aluminum, ceramic, tile, glass, and more. Water- and solvent-resistant, it is non-toxic and low in VOCs (Volatile Organic Compounds), making it safe for everyday use.

NUMBER	SIZE	EACH	6/EA
A23632-1025	0.85 oz (25 ml)	\$8.38	\$7.55

W UHU® Super Glue Control

An extremely strong adhesive with direct-stop technology to prevent drips. It bonds to most plastics, porcelain, ceramics, wood, rubber, and more.

NUMBER	SIZE	EACH	12/EA
A23954-1011	0.11 oz (3 ml)	\$6.09	\$5.48

X Elmer's® Super Glue

Bonds metal, glass, ceramics, and most plastics in just seconds. Strong, fast, versatile, and easy to use, it doesn't require solvents, catalysts, mixing, or clamping. Just one drop holds a ton! The package includes three 0.07 oz (2 g) tubes.

NUMBER	EACH	12/EA
A24231-1009	\$3.11	\$2.80

Y Gorilla™ Super Glue Micro Precise Tip

The precision tip is easy to use and allows you to apply only the amount of glue you want, exactly where you need it.

NUMBER	EACH	6/EA
A23629-1024	\$5.82	\$5.23

HEALTH & SAFETY ICONS: ●=CL / ■=Prop 65 / ▼=CL & Prop 65
See page 644 for more information.

WARNING! Products marked with a Prop 65 symbol (■ or ▼) can expose you to chemicals, including cadmium, which are known to the State of California to cause cancer and birth defects or other reproductive harm. For more information, visit P65Warnings.ca.gov.



A Blick® Glue Sticks

An all-purpose glue in your choice of white or purple. Dries clear and permanent. Use on paper, cardboard, foam board, and fabric.

NUMBER	SIZE	EACH	12/EA
A23895-1042	0.28 oz, White	\$.55	\$ 4.9
A23895-5632	0.28 oz, Purple	.55	.49
A23895-1047	0.70 oz, White	.87	.78
A23895-5637	0.70 oz, Purple	.87	.78
A23895-1048	1.41 oz, White	1.30	1.17
A23895-5638	1.41 oz, Purple	1.30	1.17

B Elmer's® Glue Sticks

All-purpose glue stick in your choice of regular or acid-free formulas. Dries clear.

NUMBER	DESCRIPTION	EACH	12/EA
A23810-1010	0.21 oz, Regular	\$.80	\$ 7.3
A23810-1020	0.77 oz, Acid-free	1.82	1.69

C Elmer's® All Purpose Washable Clear Glue Sticks

Acid-free, photo-safe, non-toxic glue sticks are perfect for young artists and classroom projects. The glue bonds to paper, cardboard, display board, and more. It glides on smoothly and doesn't leave clumps behind. Dries quickly and clear.

NUMBER	DESCRIPTION	SIZE	EACH	6/EA
A23810-1001	30 Pack	0.77 oz	\$ 47.09	\$ 42.38

D Elmer's® Washable School Glue Sticks

Non-toxic school glue sticks go on purple and dry clear, which helps kids see where they're applying glue. Smooth, acid-free, and photo-safe. Washes easily from hands and clothes.

NUMBER	DESCRIPTION	SIZE	EACH	12/EA
A23810-1030	0.21 oz, Washable		\$.80	\$ 7.3
A23810-1040	0.77 oz, Washable		1.82	1.69

NUMBER	DESCRIPTION	SIZE	EACH	12/EA
A23869-5630	30 Pack	0.21 oz	\$ 16.95	\$ 15.26
A23869-1060	60 Pack	0.21 oz	32.79	29.49

E Elmer's® Extra Strength Glue Stick

These glue sticks apply smoothly and create a permanent bond that's two times stronger than other glue sticks. Use them with paper, wood, felt, ceramics, and other craft supplies. Washable and acid-free, they're photo-safe and non-toxic. They go on purple and dry clear.

NUMBER	DESCRIPTION	EACH	12/EA
A23952-1001	2 pk, 0.21 oz	\$ 3.41	\$ 3.07
A23952-1002	0.77 oz	4.05	3.65

F Gorilla Kids Glue Sticks

Double the adhesive strength of leading school glue sticks. The disappearing purple formula is safe, non-toxic, washable, and dries clear. The glue bonds to paper, wood, fabric, foam board, felt, plastic, and more, plus it's acid-free and photo-safe.

NUMBER	DESCRIPTION	EACH	12/EA
A23976-1002	0.70 oz	\$ 3.75	\$ 3.37
A23976-1001	2 pk, 0.21 oz	3.75	3.37
A23976-1003	6 pk, 0.21 oz	6.58	5.92

G Crayola® Glue Stick

Goes on blue — dries clear! Has a large pedestal base that's hard to lose, easy to snap on, and keeps the glue stick handy. Glue level gauge lets you know when to buy more. Has a pleasant odor and is washable.

NUMBER	DESCRIPTION	EACH	12/EA
A23828-1003	0.29 oz, 2 Pack	\$ 1.61	\$ 1.45
A23828-0009	0.88 oz, 12 Pack	18.47	16.62

H Prang® Glue Sticks

Prang Glue Sticks are a staple for the classroom and at home. They twist up for less messy application. Easy to use and kid-friendly, the non-toxic formula is odorless and washable. Glue dries without wrinkling paper.

Blue Glue Sticks — Rubs on blue and dries clear.

NUMBER	SIZE	EACH	12/EA
A23943-1301	0.28 oz	\$ 1.40	\$ 1.25
A23943-1401	0.74 oz	2.65	2.38
A23943-1501	1.27 oz	3.79	3.40

White Glue Sticks — Rubs on clear and dries clear.

NUMBER	SIZE	EACH	12/EA
A23943-1101	0.28 oz	\$ 1.40	\$ 1.25
A23943-1601	0.74 oz	2.65	2.38
A23943-1701	1.27 oz	3.78	3.39

I UHU® Stic Color Glue Stick

Rubs on bright purple, so you can tell exactly where the glue lies; but once it dries, the color disappears and it's completely clear! Non-toxic and washes out of clothing.

NUMBER	SIZE	EACH	12/EA
A23822-0011	0.29 oz	\$ 1.13	\$ 1.05
A23822-0031	0.75 oz	2.47	2.20
A23822-0131	1.41 oz	3.30	2.97

UHU Stic Clear Glue Stick — Same as above, with clear application.

NUMBER	SIZE	EACH	12/EA
A23822-0010	0.29 oz	\$ 1.13	\$ 1.05
A23822-0030	0.75 oz	2.47	2.20
A23822-0130	1.41 oz	3.30	2.97

J Scotch® Glue Sticks

The permanent glue stick is available in traditional white or purple and dries clear. Both can be used on paper, cardboard, foam board, and fabric. The restickable glue stick allows ongoing repositioning, rendering paper "self-sticking."

NUMBER	DESCRIPTION	EACH	12/EA
A23832-1041	0.49 oz, Restickable	\$ 2.52	\$ 2.27
A23832-5631	0.52 oz, Perm. Purple	1.99	1.81
A23832-1051	0.52 oz, Perm. White	1.58	1.42



Blick® Essentials Multi-Purpose White Glue

Bonds to most porous and non-porous materials. Use on paper, wood, fabric, and ceramic. Wipes up with damp cloth before glue dries.

NUMBER	SIZE	EACH	24/EA
A23882-1004	4 oz (120 ml)	\$ 1.09	\$ 9.9
A23882-1005	8 oz (237 ml)	1.67	1.50
A23882-1006	16 oz (473 ml)	3.25	2.93
A23882-1009	Gallon (3.78 Liter)	13.28	11.95

Blick® Essentials Washable School Glue

Provides a strong bond on most porous materials, including paper, cardboard, cloth, leather, and wood. Easy cleanup — wipe with a damp cloth before glue dries. Washes easily from clothes and hair.

NUMBER	SIZE	EACH	24/EA
A23882-1014	4 oz (120 ml)	\$ 1.09	\$ 9.9
A23882-1015	8 oz (237 ml)	1.67	1.50
A23882-1016	16 oz (473 ml)	3.25	2.93
A23882-1019	Gallon (3.78 Liter)	13.28	11.95

Blick® Essentials Multi-Purpose Black Glue

A strong versatile black glue that's ideal for outlines and color contrast as well as faux stained glass painting projects. Bonds to most porous and nonporous material. Non-toxic. Made in the USA.

NUMBER	SIZE	EACH	24/EA
A23978-2024	4 oz (120 ml)	\$ 3.22	\$ 29.0
A23978-2025	8 oz (237 ml)	5.40	4.89
A23978-2026	16 oz (473 ml)	9.72	8.75



Elmer's® Glue-All

All-purpose, non-toxic white glue. Dries fast and clear. Won't stain. Bonds wood, paper, cloth, pottery, and all porous materials. Washes easily from brushes, clothing, fingers. In plastic jars or handy, refillable squeeze bottles.

NUMBER	SIZE	EACH	24/EA
A23886-1003	1.25 oz (37 ml)	\$ 1.38	\$ 1.24
A23887-1004	4 oz (120 ml)	2.11	1.90
A23887-1007	7.63 oz (229 ml)	2.85	2.57
A23886-1006	16 oz (473 ml)	6.05	5.43
A23887-1009	Gallon (3.78 Liter)	21.75	19.58

Glue Pump — Fits all Elmer's Glue-All and School Glue gallon bottles (glue not included).

NUMBER	EACH	6/EA
A23810-0000	\$ 29.47	\$ 26.52

Elmer's® Washable School Glue

Launders out with soap and water — even after it dries. No-clog dispenser top means no need to snip the top! Non-toxic, safe. In plastic containers.

NUMBER	SIZE	EACH	12/EA
A23810-1204	4 oz (120 ml)	\$ 1.17	\$ 1.05
A23810-1105	7.63 oz (229 ml)	1.93	1.74
A23810-1109	Gallon (3.78 Liter)	19.90	17.90

Glue Pump — Fits all Elmer's Glue-All and School Glue gallon bottles (glue not included).

NUMBER	EACH	6/EA
A23810-0000	\$ 29.47	\$ 26.52

For more sizes, visit DickBlick.com.



A-I Plaid® Mod Podge®

Glue and seal paper, fabric, and other porous materials to almost any surface. Mod Podge dries fast and holds tight, with a clear, smooth, durable finish that protects decoupage, acrylic paint, stain, fabrics, and more. Non-toxic and cleans up with soap and water.



A Fabric Formula

NUMBER	SIZE	EACH	12/EA
A02916-1010	Half Pint (237 ml)	\$6.77	\$6.08

B Gloss Finish

NUMBER	SIZE	EACH	12/EA
A02916-1108	Half Pint (237 ml)	\$6.37	\$5.73
A02916-1006	Pint (473 ml)	8.52	7.67
A02916-1007	Quart (946 ml)	16.11	14.49
A02916-1208	Half Gallon (1.89 Liter)	27.22	24.50
A02916-1009	Gallon (3.78 Liter)	35.20	31.68

D-E Mega Glitter

NUMBER	SIZE	EACH	12/EA
A02916-1405	Gold	\$10.25	\$9.22
A02916-1425	Hologram	10.25	9.22
A02916-1415	Silver	10.25	9.22

F Matte Finish

NUMBER	SIZE	EACH	12/EA
A02916-1015	Half Pint (237 ml)	\$6.37	\$5.73
A02916-1016	Pint (473 ml)	8.52	7.67
A02916-1017	Quart (946 ml)	16.11	14.49
A02916-1308	Half Gallon (1.89 Liters)	27.22	24.50
A02916-1019	Gallon (3.78 Liter)	35.20	31.68

C Paper Gloss Finish

NUMBER	SIZE	EACH	12/EA
A02916-1105	Half Pint (237 ml)	\$6.77	\$6.08
A02916-1106	Pint (473 ml)	12.84	11.55

G Paper Matte Finish

NUMBER	SIZE	EACH	12/EA
A02916-1003	Half Pint (237 ml)	\$6.77	\$6.08
A02916-1001	Pint (473 ml)	12.84	11.55

H Sparkle Finish

NUMBER	SIZE	EACH	12/EA
A02916-1005	8 oz (237 ml)	\$7.69	\$6.92

I Outdoor Finish

NUMBER	SIZE	EACH	12/EA
A02916-1008	8 oz (237 ml)	\$7.69	\$6.92



J-K Aleene's® Original Tacky Glue®

Extra-thick and extra-tacky, perfect for use with all papers, as well as wood, metal, glass, ceramics, fabric, and most plastics. Watersoluble. Dries clear and flexible when used on fabrics.

NUMBER	SIZE	EACH	36/EA
A23884-1004	4 oz (118 ml)	\$2.18	\$1.97
A23884-1008	8 oz (237 ml)	3.85	3.46
A23884-1280	Gallon (3.78 Liter)	39.05	35.15

3 pk — Three, 0.66 oz bottles of Original Tacky Glue.

NUMBER	EACH	12/EA
A23884-1003	\$2.75	\$2.47

k Variety 3 pk — Three, 0.66 oz bottles of Fast Grab Tacky Glue, Original Tacky Glue, and Quick Dry Tacky Glue.

NUMBER	EACH	12/EA
A23884-1013	\$4.03	\$3.61



Aleene's® Clear School Tacky Glue with Glue Stick

This adhesive combo pack offers one 4.8 oz multi-purpose tacky glue bottle and one 0.28 oz acid-free, photo-safe glue stick. Perfect for a variety of craft projects. Non-toxic and low odor.

NUMBER	EACH	12/EA
A23957-1048	\$5.26	\$4.73



L Delta® Sobo Craft & Fabric Glue

This general-purpose glue dries fast and clear. Freeze-thaw stable.

NUMBER	SIZE	EACH	12/EA
A23820-1004	4 oz (118 ml)	\$3.61	\$3.26

M Yes!™ Stik Flat Glue

All-purpose, lay-flat, white glue. Used by bookbinders, printers, libraries, greeting and sample card makers, to name a few. Won't buckle paper. Acid-free, smooth flowing, permanently flexible. Low odor and easy cleanup. Pint.

NUMBER	SIZE	EACH	12/EA
A23836-0006	Pint (473 ml)	\$15.59	\$14.03

Did you know we have hundreds of lesson plans designed to meet the National Standards for Visual Arts Education? See them all at DickBlick.com/lesson-plans.



Elmer's® Glow in the Dark Glue

Add some out-of-this-world detail to art and craft projects! Elmer's Glow in the Dark Glue comes in bright, neon colors — perfect for creating luminous slime or making signs pop. Glue is washable and non-toxic. 5 oz bottles.

NUMBER	COLOR	EACH	12/EA
A23945-5014	Blue	\$9.57	\$8.61
A23945-8454	Natural	9.57	8.61
A23945-3064	Pink	9.57	8.61
A23945-4014	Yellow	9.57	8.61
A23945-4514	Orange	9.57	8.61
A23945-6004	Purple	9.57	8.61



Elmer's® Color Changing Glue

This non-toxic glue changes colors in sunlight from blue to purple and yellow to red. Great for decorating and bonding materials, it adds a bit of fun to crafts and school projects. Washes easily from hands and clothing.

NUMBER	DESCRIPTION	EACH	12/EA
A23971-5015	Blue 5 oz (147 ml)	\$10.08	\$9.07
A23971-5019	Blue, 9 oz (266 ml)	17.26	15.54
A23971-4015	Yellow, 5 oz (147 ml)	10.08	9.07
A23971-4019	Yellow, 9 oz (266 ml)	17.26	15.54



Elmer's® Metallic Glue

Add unique, shimmery colors to craft projects. This glue is non-toxic, safe, and washes easily from hands and clothing. For a full bond let the glue dry overnight.

NUMBER	COLOR	EACH	12/EA
A23972-5015	Blue	\$7.15	\$6.40
A23972-3065	Pink	7.15	6.40
A23972-5085	Teal	7.15	6.40

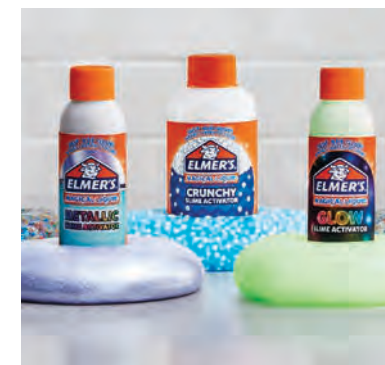

Elmer's® Magical Liquid Slime Activator

Elmer's Magical Liquid Slime Activator easily turns liquid glue into goopy slime with less mess. Start by adding 2 teaspoons of Magical Liquid Slime Activator to one 4-6 oz bottle of liquid glue and stir until blended. Keep adding one teaspoon at a time and mixing well until the desired slime consistency is reached. The 8.75 oz bottle makes up to eight batches of slime. Washable and non-toxic, the slime activator replaces contact solution and baking soda.

NUMBER	EACH	12/EA
A24078-1008	\$10.53	\$9.48

Crunchy — Makes slime crunch and crackle as you play.

NUMBER	EACH	12/EA
A24078-1001	\$4.50	\$4.05

Glow in the Dark — Makes luminescent slime that glows in the dark.

NUMBER	EACH	12/EA
A24078-1003	\$5.48	\$4.93

Metallic — Makes glistening, iridescent slime.

NUMBER	EACH	12/EA
A24078-1004	\$4.50	\$4.05



Elmer's® Washable Color Glue

Jazz up school and craft projects, or create vibrantly colored slime. Non-toxic and safe for kids, Elmer's Transparent Color Glue is washable and doesn't stain hands. 5 oz bottles.

NUMBER	COLOR	EACH	12/EA
A23950-5014	Blue	\$5.24	\$4.73
A23950-7014	Green	5.24	4.73
A23950-3064	Pink	5.24	4.73
A23950-6004	Purple	5.24	4.73



Elmer's® Washable Clear School Glue

Glue goes on clear, dries clear, and washes out easily with soap and water — even after it dries. Bottle features a non-snip, no-clog dispenser top. Safe, non-toxic formula is ideal for small children. It's even tintable for a hint of color. Use on paper, cloth, and craft projects.

NUMBER	SIZE	EACH	12/EA
A23810-1600	5 oz (147 ml)	\$3.11	\$2.79
A23810-1601	9 oz (266 ml)	6.96	6.25
A23810-1050	16 oz (473 ml)	7.39	6.78
A23810-1060	32 oz (946 ml)	12.50	11.25



SUREBONDER®



Surebonder® Safety Fuse Glue Guns

Safety fuse guns shut down automatically if they overheat. The ergonomic designs are easy to handle and feature a removable base with "fins" that allow the guns to lie on their sides without the glue backing up.

Full Size	NUMBER	TEMPERATURE	EACH	12/EA
	A24736-1040	Low Temp	\$13.57	\$12.21
	A23635-1040	High Temp	13.57	12.21
	A23635-1002	Dual Temp	20.05	18.05

Mini	NUMBER	TEMPERATURE	EACH	12/EA
	A23635-1020	Low Temp	\$5.30	\$4.77
	A23635-1010	High Temp	5.30	4.77
	A23637-1000	Dual Temp	12.69	11.42

Surebonder® Ultra Dual Temp Glue Gun

New, top-of-the-line upgrades to Surebonder's classic glue gun. Choose from three wattages that offer faster gluing. Dual temperature capabilities suit a variety of projects. Its redesigned body promotes easy lay down and prevents glue backup. Rubber accents and an insulated nozzle offer comfort and protect against burns. Glue gun features auto shut-off technology that turns it off if it hasn't been used in 30 minutes.

NUMBER	SIZE	EACH	12/EA
A23937-1001	20 Watt	\$14.98	\$13.48
A23937-1002	60 Watt	16.19	14.57
A23937-1003	100 Watt	36.53	32.88

Glue Gun Stand

NUMBER	EACH	12/EA
A23627-1001	\$5.06	\$4.55



Colored Mini Sticks

Surebonder® Cool Shot™ Super Low Temperature Mini Glue Gun

Features a super low temperature and insulated nozzle that make it safer for kids to use than other low temperature glue guns. Ideal for school projects and crafts, the Cool Shot features a comfortable, ergonomic handle. Glue dispenses quickly and dries in seconds. Use only with Cool Shot Mini Sticks or Cool Shot Colored Mini Sticks.

NUMBER	DESCRIPTION	EACH	6/EA
A23631-1000	Cool Shot Glue Gun	\$10.28	\$9.25
A23933-1001	Regular Mini Sticks, Pkg of 40	7.29	6.56
A23631-1001	Regular Mini Sticks, Pkg of 15	3.49	3.15
A23631-1049	Colored Mini Sticks, Pkg of 15	4.21	3.78



Surebonder® Mini Cordless USB Glue Gun

Glue wire-free with this mini, cordless glue gun. It charges via USB cord for easy gluing in small, tight areas. It has an insulated nozzle and a safety fuse. Each charge lasts 75 minutes. Wall adapter not included.

NUMBER	EACH	12/EA
A23935-1001	\$28.40	\$25.56



Surebonder® 80W Professional Glue Guns

A versatile, full-size, professional-quality glue gun. With a high operating temperature of 380°F, glue sticks melt more quickly and form a stronger bond. Other convenient features include an easy-pull trigger, a built-in stand, and a non-stick finish for easier cleanup. Use with standard 7/16" diameter glue sticks (sold separately).

NUMBER	TEMPERATURE	EACH	12/EA
A23627-1080	High Temp	\$28.37	\$25.53
A23609-1080	Dual Temp	39.45	35.49



Surebonder® Mini-Trigger Glue Guns

Compact, lightweight, and easy to handle, Surebonder Mini-Trigger Glue Guns are great for classroom use! Each glue gun has a built-in stand that keeps the tip safely elevated while in use. Use with 5/16" diameter glue sticks (sold separately).

High-Temp Mini Gun — Operates at 300°F.

NUMBER	EACH	12/EA
A23601-0100	\$7.18	\$6.45

Low-Temp Mini Gun — Operates at 230°F.

NUMBER	EACH	12/EA
A23601-0000	\$7.18	\$6.45

Dual-Temp Mini Gun — Operates at either 300°F or 230°F.

NUMBER	EACH	12/EA
A23601-0200	\$13.35	\$11.99



Surebonder® Cordless Heavy-Duty 60W Glue Gun

Get your projects done more quickly and easily without a power cord to limit your movement! 380°F operating temperature offers greater liquidity and better bonding. You can use the gun for three minutes before it needs to be reheated on the charging base, which is equipped with a drip pad to help keep your workspace neater. Use with standard 7/16" diameter glue sticks (sold separately).

NUMBER	EACH	12/EA
A23627-1060	\$23.76	\$21.38



Gorilla Glue Mini Hot Glue Sticks

These 4" glue sticks are weather-resistant for both indoor and outdoor use, providing a long-term hold on even hard-to-bond surfaces like metal, stone, and glass. The clear adhesive works with both high and low temperature glue guns and features an extended working time for added convenience.

NUMBER	DESCRIPTION	EACH	6/EA
A23975-1001	10 pk	\$2.74	\$2.47
A23975-1002	30 pk	4.39	3.95



Surebonder® Best Stik Special Surface Glue Sticks

These glue sticks are specially formulated to adhere to difficult surfaces. Great for a variety of projects, they are compatible with all standard size glue guns operating at any temperature. 4" long and approximately 7/16" in diameter.

NUMBER	DESCRIPTION	SIZE	EACH	25/EA
A23617-1007	12 pk	4" Length	\$4.56	\$4.10



Surebonder® Wood Stik Glue Sticks

Specially formulated for bonding wood. Compatible with all standard size glue guns operating at any temperature. Made in the USA. 7/16" Dia x 4"L. Sold in a package of 12.

NUMBER	EACH	25/EA
A23617-1006	\$4.56	\$4.10



Westcott® ProjectMate All Temperature Mini Glue Sticks

All temperature, 7 mm diameter glue sticks. They are perfect for use with the Westcott ProjectMate Mini Glue Gun and Premium Hot Glue Pen. 30 sticks per pack.

NUMBER	DESCRIPTION	EACH	12/EA
A23948-1001	30 pk	\$11.47	\$10.36



Gorilla Glue Dual Temp Mini Glue Gun

The lightweight mini glue gun has an easy squeeze trigger with a comfort grip and a long insulated nozzle for precise application on crafts and repairs. It features a built-in stand and side fins so the glue gun can lay on its side. The low and high switch allows for dual temperatures. For use with mini glue sticks only.

NUMBER	EACH	6/EA
A23974-1001	\$12.11	\$10.89



Surebonder® Adjustable Temp Electric Glue Skillet

The glue skillet keeps glue melted and ready for quick home décor projects such as wreaths and other floral work. Simply dip the pieces into the hot melt adhesive and put them in place. Use with Surebonder Diamond Cubes Skillet Glue for best results. The adjustable temperature goes from approximately 220°F to 400°F. Anti-slip feet ensure the skillet stays in place, and the lighted on/off switch lets you easily tell if the skillet is on.

NUMBER	DESCRIPTION	EACH	6/EA
A24740-1001	Glue Skillet	\$54.50	\$49.05

Pellets — Superior bonding capabilities with less stringing. 1 lb bag.

NUMBER	EACH	6/EA
A24741-1001	\$9.65	\$8.69

Surebonder Glue Gun Silicone Pad

Protect your work surfaces and say goodbye to hot glue messes! Heat-resistant up to 400°F, the Surebonder Glue Gun Silicone Pad has a non-stick surface, so dried glue simply peels off.

Round	NUMBER	EACH	12/EA
	A24337-1004	\$9.90	\$8.91

Square	NUMBER	EACH	12/EA
	A24337-1005	\$41.53	\$37.38



Elmer's® CraftBond® Hot Glue Guns

All guns are designed with a trigger-fed mechanism to provide continual glue flow. Built-in lifts on both sides allow them to rest safely on their sides without glue backup. Added safety features include an insulated nozzle to safeguard against burns and a safety fuse that shuts the gun off automatically if overheated.

NUMBER	DESCRIPTION	EACH
A23917-1240	Dual Temp Full Size	\$15.10
A23917-1020	Dual Temp Mini	10.99
A23917-1140	High Temp Full Size	13.50
A23917-1010	High Temp Mini	7.99



Surebonder® Colored Mini Glue Sticks

These 4" glue sticks measure 5/16" in diameter and are great for use in either high or low temperature glue guns. They're non-toxic and ideal for a variety of crafts and school projects. Use them to embellish clothes, jewelry, home décor, and more. Made in the USA.

Assorted Glitter — Includes two each of Silver, Gold, Blue, Green, Opal, and Red.

NUMBER	EACH
A23602-1034	\$5.13

Glow in the Dark — Package of 15.

NUMBER	EACH
A23602-1054	\$5.63

Assorted Variety — Includes two each of Bright Pink, Lime Green, and Teal and three each of Black and White.

NUMBER	EACH
A23602-1074	\$3.33





A StikkiWorks® Classroom Clips
Perfect for hanging light- to medium-weight objects, Classroom Clips have a strong grip — perfect for holding projects together while gluing and displaying work. The 2" long clips have two holes for easy threading. Includes 20 clips.

NUMBER	EACH	12/EA
A57373-1020	\$7.25	\$6.53

B Acco® Magnetic Bulldog Clip
A strong spring mechanism holds up to 7/8" of larger, heavier documents in this clip's wide metal jaws, and a super-strong magnet attaches to metal surfaces for increased visibility. Measures 1-1/2" Sq.

NUMBER	EACH	12/EA
A57333-1015	\$2.81	\$2.53

C X-Acto® Bulldog Clips
Steel with a bulldog-tough spring. Binder capacity up to 3".

NUMBER	SIZE	BOX OF	EACH	12/EA
A57305-1001	1"	36	\$13.47	\$12.13
A57305-1022	2-1/4"	36	19.40	17.49
A57305-1003	3"	12	15.99	14.41

D Acco® Clips
Efficient triangular design offers a powerful grip, yet releases easily. Removable handle folds down to simplify filing and storage — or keep one handle up for a convenient hanger. Rust-resistant steel construction. Boxes of 12.

NUMBER	DESCRIPTION	EACH	48/EA
A57330-4034	Small 3/4"	\$2.03	\$1.83
A57330-4114	Medium 1-1/4"	3.85	3.46
A57330-1002	Large 2"	9.90	8.91

E Officemate® Rubber Bands
Officemate Rubber Bands are an excellent combo of strength and value. Use them to keep crafts, tools, and other items organized. Made of pure, natural rubber. Each 1.38 bag contains an assortment of natural colored rubber bands.

NUMBER	EACH	12/EA
A56894-1001	\$3.87	\$3.49

F Officemate® Staple Remover
Remove staples easily without tearing paper. This staple remover is made with quality nickel-plated steel and a recycled plastic handle that's easy to grip. It operates quickly and efficiently to get the job done.

NUMBER	EACH	12/EA
A58149-1001	\$2.46	\$2.21

G Officemate® One-Hole Punch
Punch through up to five sheets of paper with the Officemate One-Hole Punch. It makes round 1/4" holes and has a 1" reach. This nickel-plated handheld punch has an attached chip catcher.

NUMBER	EACH	12/EA
A57349-1001	\$3.39	\$3.06

H Acco® Jumbo Pack of Clips and Pins
625 clips and pins in Acco's most popular styles, colors, and sizes: 350 jumbo paper clips, 45 binder clips (15 each of mini, small, and medium), 80 butterfly clips, and 150 jumbo pushpins. In four stackable and reusable plastic tubs.

NUMBER	EACH	3/EA
A57336-3500	\$59.90	\$53.91



I Swingline® LightTouch® Heavy-Duty Hole Punch
Wide grip, soft-touch lever requires up to 50% less punching effort than standard punches, but does not sacrifice quality, power, or flexibility. Punches up to 20 sheets of 20 lb paper with 9/32" holes and accepts 2-7 punch heads. Limited lifetime warranty.

NUMBER	EACH	3/EA
A57335-9330	\$60.55	\$54.49

J Bostitch® Classic Metal Desktop Stapler
Renowned for durability and performance. All-metal construction. Easily handles up to 20 sheets at once. Uses standard staples and accommodates full strips of 210. Limited lifetime warranty.

NUMBER	EACH	12/EA
A35145-2020	\$11.46	\$10.31

K Swingline® 747® Stapler
Consistent performance makes this workhorse an industry standard and America's #1 stapler. Solid metal construction offers years of durability and stapling integrity. Staples up to 20 sheets of 20 lb paper at once and opens for tacking with lock latch.

NUMBER	EACH	12/EA
A57231-2050	\$27.99	\$25.21

Swingline SF4 Premium Office Staples

NUMBER	DESCRIPTION	EACH	20/EA
A57230-1025	Box of 5000	\$5.42	\$4.87

L Bostitch® 12" Long Reach Stapler
Excellent for stapling pamphlets, booklets, and brochures. Engineered to eliminate staple jams. Uses standard staples. Adjustable paper stop with easy-to-read English/metric rulers. Anchor holes for mounting to table or workbench. Solid metal construction.

NUMBER	EACH	6/EA
A57222-2000	\$42.59	\$38.33



M Surebonder® Easy Tacker Stapler
This economical, light-duty staple gun features lightweight plastic construction and an easy-squeeze handle. Great for household or office use. Includes 100 staples. Easy drop-in loading. Use with Surebonder #3 staples (sold separately).

NUMBER	EACH	3/EA
A57235-1001	\$15.20	\$13.68

N Surebonder® Triggerfire™ Stapler Gun Kit
With one-handed operation, this staple gun can be used either with the trigger or as a non-automatic stapler. Plastic body with a cushioned, non-slip handle. Use with Surebonder #4 staples, #8 brad nails, and #9 pin nail staples (sold separately). Includes 720 staples, two strips each of 1/4", 5/16", 3/8", and 1/2".

NUMBER	EACH	6/EA
A58154-1001	\$25.41	\$22.86

O Surebonder® Heavy-Duty 3-in-1 Staple Gun
Sets staples, pin nails, and brad nails for three times the utility. Made of heavy-duty steel with a durable chrome finish. Easy drop-in loading. Ergonomic, non-slip grip. Adjustable drive. Use with 3/8" (8 mm) staples, #8 brad nails, or #9 pin nails (sold separately).

NUMBER	EACH	3/EA
A35108-1001	\$25.84	\$23.25

P Surebonder Light Duty Staple Gun
Ideal for small repairs and crafting, this ergonomic stapler has a cushioned handle for comfort and is easy to load thanks to the drop-in design. For use with Surebonder #3 or Arrow JT-21 staples.

NUMBER	EACH	3/EA
A57235-1002	\$13.33	\$11.99

Q Surebonder® Staples
These heavy and light duty staples are ideal for use with Surebonder Staple Guns and other staple guns.

Light Duty #3 Staples — Boxes of 1,000.

NUMBER	DESCRIPTION	EACH	12/EA
A58148-1014	1/4" Leg	\$1.68	\$1.52
A58148-1516	5/16" Leg	1.68	1.52
A58148-1038	3/8" Leg	2.19	1.97

Heavy Duty #4 Staples — Box of 1,250.

NUMBER	DESCRIPTION	EACH	3/EA
A35108-1002	3/8" Leg	\$3.55	\$3.19

R Arrow™ JT21CM™ Staple Gun
Household staple gun is for light to medium work. Features long-lasting all-steel chrome construction, easy-grip contoured handle, jam-proof mechanism, built-in staple lifter, and a visual refill window. Uses only JT21 staples (sold separately).

Arrow JT21 Staples — Boxes of 1,000.

NUMBER	DESCRIPTION	EACH	24/EA
A57219-1025	1/4" Leg	\$2.53	\$2.27
A57219-1031	5/16" Leg	2.53	2.27

S Stanley® TR150 Heavy-Duty SharpShooter®
The SharpShooter delivers high-power penetration with an easy-squeeze, anti-jam design. It's constructed with a durable aircraft-grade aluminum housing that withstands heavy, long-term use. Easy-slide, full-stick staple loading.

NUMBER	EACH	6/EA
A57239-4020	\$44.59	\$40.15

SharpShooter TRA Series Staples — Box of 1,000.

NUMBER	SIZE	EACH	10/EA
A57223-1000	3/8" Leg	\$4.93	\$4.43
A57238-1006	5/16" leg	3.89	3.50
A57238-1005	1/2" leg	5.07	4.56



Peta™ Mounted Tabletop Scissors

Specially designed for one-handed use or for use by children with very limited strength and control. The safe, stable, green plastic base holds firm to any table while the child depresses the large, T-shaped handle to make a successful cut. The no-slip base measures 3"H x 12-14"L x 3-1/2"W.

NUMBER	EACH	6/EA
A58476-1001	\$37.98	\$34.18



Peta™ Easi-Grip® Scissors

Ideal for early scissor skill development, or for students who are physically unable to use conventional scissors. The ultra-lightweight handle has a rear loop that makes cutting action easy and automatically springs back into the ready position after each cut. Choose from a full-size, right-handed model (7-1/4"L), or a mini model that generally works for both right-handed and left-handed users.

NUMBER	SIZE	EACH	12/EA
A58472-1001	5"	\$8.81	\$7.93
A58472-1002	7-1/4"	12.11	10.90



Fiskars® Paper Edgers

Edge stationery, photographs, rubber stamp projects, stencil designs, and other creations. Ergonomically designed handles are over-sized to fit comfortably in both left and right hands. Blades give long, clean, precise cuts. Set of 6.

NUMBER	EACH	6/EA
A57033-1600	\$16.43	\$14.78



Fiskars® Softgrip® Kids Scissors

Kids love the colorful, comfortable "splash" grip. Teachers and parents love the safe design! Innovative safety-edge blades cut paper but not skin, hair, or clothes. Assorted colors. Ages 4+.

NUMBER	DESCRIPTION	SIZE	EACH	12/EA
A57618-1005	Blunt	5"	\$3.97	\$3.57
A57619-1005	Pointed	5"	3.97	3.57



Fiskars® Student Scissors

Both right- and left-handers will find these scissors comfortable to use. Stainless steel blades. Handle color may vary. Ages 12+.

NUMBER	SIZE	EACH	12/EA
A57016-1065	7"	\$5.78	\$5.20



Fiskars® Graduate Scissors

These adult-sized scissors are great for teens, parents, and teachers. The blade cuts through a variety of materials, and the ergonomic handle provides comfort and control. Can be used right- or left-handed. Handle color may vary.

NUMBER	SIZE	EACH	12/EA
A57602-1008	8"	\$6.03	\$5.42



Fiskars® Sparkle Softgrip® Non-Stick Student Scissors

These 7" scissors feature pointed-tip, non-stick stainless steel blades with a lasting edge for excellent cutting performance on a variety of materials. The sparkly Softgrip handles have a larger finger loop and an ergonomic thumb loop, reducing hand fatigue. These scissors come in assorted colors (we choose). Ideal for right- or left-handed users. Ages 12 and up.

NUMBER	SIZE	EACH	12/EA
A57666-1007	7"	\$7.05	\$6.34



A-C Fiskars® for Kids

Comfortable, controllable, and fun for kids to use! Stainless steel blades with plastic handles in assorted neon colors. Ages 4+.

NUMBER	DESCRIPTION	SIZE	EACH	12/EA
A57010-1005	A Blunt	5"	\$3.26	\$2.93
A57010-1001	B Pointed	5"	3.26	2.93

12-Packs

NUMBER	DESCRIPTION	SIZE	EACH	6/EA
A57010-1003	C Blunt	5"	\$36.07	\$32.46
A57010-1002	Pointed	5"	36.07	32.46



Fiskars® Scissors Class Pack

This pack of 24 blunt-tip scissors comes in a compact carrier, making it easy to distribute, store, and transport. Carrier has a large handle, sturdy base, and four removable plastic cups. Scissors can be used right- or left-handed. Ages 4+.

NUMBER	DESCRIPTION	SIZE	EACH
A57085-1009	Blunt	5"	\$67.32
A57085-1024	Pointed	5"	67.32

Fiskars Scissors are backed by a lifetime warranty.



Fiskars® Sparkle Scissors

Craft in style! These 8" scissors have high-grade, precision ground, stainless-steel blades with a lasting, sharp edge that cut to the tips of the blades. Ideal for cutting denim, silk, multiple layers of fabric, and a variety of other materials, these scissors feature comfortable ergonomic handles for maximum control and sparkly handles for added pizzazz.

NUMBER	COLOR	EACH	12/EA
A58486-3718	Berry	\$19.81	\$17.83
A58486-9508	Copper	19.81	17.83
A58486-9018	Gold	19.81	17.83
A58486-9338	Silver	19.81	17.83



Fiskars® Non-Stick™ Bent Scissors

These scissors can cut through glue, tape, hook-and-loop, and other adhesives without damaging the blades. Any sticky material will wipe off easily with a dampened cloth. Stainless steel blades.

NUMBER	SIZE	EACH	6/EA
A57052-1008	8"	\$16.30	\$14.67



Fiskars® Premier® Softgrip® Titanium Non-Stick Scissors

The legendary 8" Fiskars orange-handled scissors design has been updated with non-stick, titanium-enhanced blades and a more comfortable, ergonomic handle. Cut a wide variety of materials including denim, silk, multiple layers of fabric, and sticky materials. High-grade, precision-ground stainless steel blades.

NUMBER	SIZE	EACH	12/EA
A57663-1008	8"	\$24.15	\$21.73



Fiskars® Easy Action™ Scissors

Stainless steel blades with adjustable tension and a unique spring-action design that greatly reduces hand strain and fatigue. The Softgrip handle adds comfort. Cut fabric, felt, paper, and more. Can be used left- or right-handed.

NUMBER	EACH	12/EA
A57017-0000	\$21.65	\$19.49



Fiskars® Bent Handle Scissors

The unique design of these scissors allows them to glide smoothly along flat surfaces, making them ideal for paper crafts and more. Comfort-molded handle and precision-ground stainless steel blades assure a clean and accurate cut every time.

NUMBER	DESCRIPTION	SIZE	EACH	12/EA
A57012-1008	Right-Handed	8"	\$15.37	\$13.83
A57038-1008	Left-Handed	8"	15.37	13.83



Fiskars® Straight Handle Scissors

The pointed blades on these scissors are stainless steel for accurate cutting. Plastic handles are designed for maximum comfort.

NUMBER	SIZE	EACH	12/EA
A57013-1005	5"	\$12.98	\$11.68



Fiskars® Premier® Softgrip® Titanium Scissors

These 8" multi-purpose scissors have Softgrip contoured handles that provide superior grip and comfort. Precision ground, hardened, straight stainless steel blades feature a titanium nitride coating that resists wear, scratches, and corrosion. For multi-purpose cutting.

NUMBER	SIZE	EACH	12/EA
A57664-1018	8"	\$18.24	\$16.42



Fiskars® Amplify® Mixed Media Shears

Engineered to cut cleanly through multiple layers of thick, heavy material, such as cardstock, magnet sheets, chipboard, fiberglass, cloth, and more. When the blades begin to separate in response to something particularly thick or rigid, the torsion bar forces the blades back together at an optimal angle for effective cutting. Protective sheath included.

NUMBER	SIZE	EACH	6/EA
A58481-1008	8"	\$29.48	\$26.53

FISKARS®



Fiskars® Performance Scissors

An all-purpose pair for everyday tasks. Versatile and lightweight, they feature hardened stainless steel blades for sharpness and durability and compact handles for greater control.

NUMBER	SIZE	EACH	12/EA
A57661-1007	7"	\$7.07	\$6.36



D-E Fiskars® Performance Softgrip® Titanium Scissors

These scissors feature precision ground stainless steel blades with a titanium coating for long-lasting sharpness. Contoured Softgrip handles are ideal for extended cutting sessions. The 5" scissors have a non-stick coating that's great for cutting tape and other sticky materials.

NUMBER	DESCRIPTION	SIZE	EACH	12/EA
A57612-1005	D Detail	5"	\$9.29	\$8.36
A57612-1008	E All-Purpose	8"	10.14	9.13



Fiskars® Recycled Performance Scissors

Hardened stainless steel blades for lasting sharpness and smooth cutting action for everyday tasks. Comfortable double-loop handles contain 90% post-consumer recycled plastic. The lightweight design offers right- and left-handed users good control with a variety of materials, including paper, cardstock, and light fabrics.

NUMBER	SIZE	EACH	12/EA
A57665-1006	6"	\$8.63	\$7.76
A57665-1008	8"	10.66	9.59



Fiskars® Razor-Edge Softgrip® Scissors

Cut through multiple layers of heavy material with minimal hand fatigue. Hardened stainless steel blades cut all the way to the tip — essential for anyone who cuts fabric. Ergonomic Softgrip handle provides control and comfort, and the bent design keeps materials flat.

NUMBER	SIZE	EACH	12/EA
A57622-1008	8"	\$28.75	\$25.88



Armada® Paper Shapers®

More than scissors — shapers! Use them to make unique borders, greeting cards, 3-D designs, and more. Shapers work on colored paper, acetate, tinfoil, fabric, and other materials. 2-3/4" cut length. Lifetime guarantee.

Set of 5, Victorian — Inchworm, Wave, Pinking, Heartbeat, and Victorian patterns.

NUMBER	EACH	12/EA
A57056-1010	\$10.49	\$9.44

Set of 5, Royal — Deckle, Cracker, Provincial, Bubble, and Royal patterns.

NUMBER	EACH	12/EA
A57056-1011	\$10.49	\$9.44

Set of 12, A — Pinking, Inchworm, Scallop, Flash, Wave, Heartbeat, Ripple, Victorian, Stamp, Jigsaw, Royal, and Rockies in a sturdy oak stand.

NUMBER	EACH	12/EA
A57056-1007	\$31.49	\$28.33

Set of 12, B — Dragonback, Deckle, Bat Wings, Bell, Imperial, Cracker, Colonial, Majestic, Arabian, Provincial, Bubbles, and Large Pinking in a sturdy oak stand.

NUMBER	EACH	12/EA
A57056-1008	\$31.49	\$28.33



Crayola® Scissors

Created to fit kids' hands, these scissors feature a curved handle design that improves the comfort of cutting. Can be used right- or left-handed.

NUMBER	DESCRIPTION	SIZE	EACH	6/EA	12/EA
A57039-0002	Blunt	5-1/4"	\$2.27	\$2.03	\$1.93
A57039-0001	Sharp	5-1/4"	2.27	2.03	1.93



Scotch® Multi-Purpose Scissors

These scissors' sharp, high-quality stainless steel blades are perfect for everyday use at home or around the studio. Comfort-grip handles. Can be used right- or left-handed.

NUMBER	SIZE	EACH	12/EA
A57096-1008	8"	\$4.62	\$4.15



Tonic Studios® Arts & Crafts Plus Scissors

Great for arts and crafts or sewing, these scissors cut with ease and precision. Stainless steel blades and ergonomic plastic handles. For right- or left-handed users.

NUMBER	SIZE	EACH	6/EA	12/EA
A57079-1008	8"	\$9.23	\$8.30	\$7.89



Armada® Kids Velvet Touch™ Scissors

Cut felt, cardboard, paper, and more with precision. Heavy-gauge stainless blades. Sturdy plastic handle with rubberized comfort grip. Can be used right- or left-handed.

NUMBER	DESCRIPTION	SIZE	EACH	12/EA	24/EA
A57062-1005	Blunt	5"	\$3.72	\$3.35	\$3.18
A57062-2005	Pointed	5"	3.72	3.35	3.18



Armada® Lollypops™ Scissors

Fun scissors in an array of colors! Same model fits both right- or left-handed students. Hardened stainless steel blades guaranteed for a lifetime (if used correctly).

NUMBER	SIZE	EACH	12/EA	24/EA
A57057-1007	7"	\$4.39	\$3.95	\$3.75



Armada® Precision Teacher's Scissors

Easily cut through tough materials. Scissors have large molded handles for a firm, comfortable grip. Right-handed.

NUMBER	SIZE	EACH	3/EA	6/EA
A57037-1005	8-1/4"	\$5.41	\$4.87	\$4.63



Armada® Precision Cost Cutters

Great quality at a great price. Cost Cutters feature stainless steel blades and ABS plastic handles. Ideal for a range of classroom projects. Right-handed.

NUMBER	SIZE	EACH	12/EA	24/EA
A57609-1007	7"	\$3.75	\$3.38	\$3.21
A57609-1008	8"	4.23	3.80	3.61



Tonic Studios® Kushgrip Scissors

These general-purpose scissors feature stainless steel blades and patented ergonomic Kushgrip handles. Use for hours at a time without fatigue. For cutting fabrics, paper, and many other materials.

NUMBER	DESCRIPTION	SIZE	EACH	6/EA	12/EA
A57150-1006	Right or Left	6"	\$10.32	\$9.28	\$8.81
A57150-1085	Right-Handed	8-1/2"	14.83	13.33	12.67
A57150-2085	Left-Handed	8-1/2"	14.83	13.33	12.67



Tonic Studios® Kids Scissors Classroom Packs

Economical 12-packs perfect for the classroom. Scissors feature comfortable Kushgrip handles and come with a display base for easy storage. A non-stick blade coating prevents sticky buildup. Right-handed.

NUMBER	DESCRIPTION	SIZE	EACH	6/EA	12/EA
A57080-1001	Blunt	5"	\$42.47	\$38.23	\$36.31
A57080-1002	Pointed	5"	42.47	38.23	36.31



Snippy® Scissors

Uniquely shaped handles ease cutting and maneuverability. Hardened stainless steel blades and sturdy construction will last a lifetime. They cut fabric, thick felt, and even posterboard. 5-1/4"L with a 1-1/2" cut.

NUMBER	DESCRIPTION	EACH	12/EA	24/EA
A57040-1005	Blunt, Right-Handed	\$1.55	\$1.39	\$1.32
A57040-2005	Pointed, Right-Handed	1.55	1.39	1.32
A57040-3002	Blunt, Left-Handed	1.55	1.39	1.32

12-Packs

NUMBER	DESCRIPTION	EACH	6/EA
A57040-1009	Blunt, Right-Handed	\$14.84	\$13.37
A57040-2009	Pointed, Right-Handed	14.84	13.37



Westcott® Kids Value® Scissors

When you're looking for value that meets the general needs of the classroom, Westcott's Value line of scissors can't be beat. These scissors feature stainless steel blades and comfortable plastic handles that are suitable for left- and right-handed use. Limited 5-year warranty.

NUMBER	DESCRIPTION	SIZE	EACH	12/EA
A57058-1015	Blunt	5"	\$3.31	\$2.98
A57058-1025	Pointed	5"	3.31	2.98

12-Packs

NUMBER	DESCRIPTION	EACH	6/EA
A57058-2012	Blunt	\$39.97	\$35.97
A57058-3012	Pointed	39.97	35.97



A Westcott® Basic Soft Handle Scissors Teacher 12-Pack

Pack of 12 pairs of scissors in a variety of fun colors. Handles are designed for left- or right-hand use and have a cushioned insert for comfortable cutting. Strong stainless steel blades. Limited 5-year warranty.

NUMBER	DESCRIPTION	SIZE	EACH	12/EA
A58477-1005	Blunt	5"	\$26.35	\$23.71
A58477-1105	Pointed	5"	26.35	23.71

B Westcott® Kleencut Kids Scissors 12-Pack with Rack

Sets of 12 lightweight, all-purpose stainless steel scissors in a reusable rack. They come in three colors and can be used by right- or left-handed kids.

NUMBER	DESCRIPTION	SIZE	EACH	3/EA
A57027-1009	Blunt	5"	\$21.78	\$19.59
A57027-1109	Sharp	5"	21.78	19.59



Westcott® KleenEarth® Recycled Scissors

True to their name, KleenEarth scissors feature handles made from 70% recycled plastic (including 30% post-consumer content). The sharp, lightweight blades are made of stainless steel. Can be used right- or left-handed. 10-year warranty.

NUMBER	DESCRIPTION	SIZE	EACH	12/EA
A57624-2007	Bent Handle	7"	\$7.29	\$6.56
A57624-2018	Straight Handle	8"	7.89	7.05
A57624-2008	Bent Handle	8"	7.89	7.05



Westcott® Antimicrobial Student Scissors

The handles of these scissors are treated with antimicrobial protection to inhibit the growth of bacterial odors. Stainless steel blades. Can be used right- or left-handed. Limited 10-year warranty.

NUMBER	DESCRIPTION	SIZE	EACH	12/EA
A57607-1007	Soft Handle	7"	\$12.49	\$11.24
A57607-2007	Plastic Handle	7"	11.99	10.79



Westcott® All Purpose Preferred® Scissors

Lightweight and comfortable, with durable stainless steel blades and adjustable blade tension, these scissors are ideal for everyday use. Can be used by right- or left-handers.

NUMBER	DESCRIPTION	SIZE	EACH	12/EA
A57608-4877	Straight Blue Handle	7"	\$12.47	\$11.23
A57608-4858	Straight Blue Handle	8"	13.96	12.56
A57608-4868	Bent Blue Handle	8"	13.96	12.56
A57608-2988	Bent Red Handle	8"	6.99	6.29
A57608-1008	Set of 3 Straight Handle	8"	15.16	13.65



Westcott® Titanium Bonded™ Scissors

Titanium bonded blades that are three times harder than stainless steel so they stay sharper longer and resist corrosion. They also repel the stickiness of tapes and glues. Contoured soft grip handles make cutting more comfortable. Can be used right- or left-handed. Limited lifetime warranty.

NUMBER	SIZE	EACH	12/EA
A57059-1007	7"	\$12.84	\$11.54
A57059-1008	8"	14.06	12.64



Westcott® Non-Stick Titanium Bonded™ Scissors

Their breakthrough non-stick coating cuts with ease but resists adhesive buildup from tapes, glues, and other sticky stuff. Lightweight and comfortable, they feature titanium bonded blades that stay sharper longer. Gray/yellow handles. Can be used right- or left-handed. Limited lifetime warranty.

NUMBER	DESCRIPTION	SIZE	EACH	12/EA
A57604-1006	Straight Handle	5"	\$16.53	\$14.88
A57604-2647	Straight Handle	7"	21.12	18.99
A57604-2628	Straight Handle	8"	23.91	21.52
A57604-2638	Bent Handle	8"	23.91	21.52



Maped® Zenoa Fit Multi-Purpose Scissors

A work of art themselves, fun and funky Zenoa Fit Scissors feature comfortable soft-grip handles embellished with a vivid, wear-proof design. The sharp, durable stainless steel blades are securely attached to the handles. Backed by a manufacturer's 10-year warranty. Assorted colors (we choose).

NUMBER	DESCRIPTION	SIZE	EACH	12/EA
A57658-1007	Universal Student	7"	\$4.59	\$4.12
A57658-1017	Right Hand	7"	5.93	5.34
A57658-1008	Right Hand	8-1/4"	7.23	6.52



Maped® Expert Titanium Scissors

Titanium-coated blades make them strong, while handles made from 79% recycled plastic make them green! Designed for excellent resistance to wear and tear. Guaranteed to last for more than 200,000 cuts. Can be used right- or left-handed.

NUMBER	SIZE	EACH	12/EA
A58469-1008	8"	\$8.26	\$7.43



Slice® Ceramic Scissors

Safer than metal and longer lasting, too! Slice Ceramic Scissors cut materials effectively but resist cutting skin thanks to patented finger-friendly blades. Great in studio, home, and classroom settings, these lightweight, durable safety scissors can be used left- or right-handed and cut a wide range of materials.

NUMBER	SIZE	EACH	12/EA
A50586-1001	5-1/2"	\$33.06	\$29.75





8-1/4"

Maped® Advanced Recycled Scissors



Handles are made of 70% recycled plastic with a supremely comfortable, ergonomic design. The sharp stainless steel blades have a unique rounded shape and are firmly riveted to the handle for long-lasting quality. Right handed. Backed by a manufacturer's five-year warranty.

NUMBER	SIZE	EACH	12/EA
A57655-1007	7"	\$4.10	\$3.40
A57655-1825	8-1/4"	4.69	3.89



8-1/4"

Maped® Advanced Gel Scissors

Gel-infused handles make these scissors extra comfortable. Whether you're right- or left-handed, they let you easily slice through paper, cardboard, plastic, acetate, and other materials. The sharp stainless steel blades are securely riveted for years of high performance. Backed by a manufacturer's 5-year warranty.

NUMBER	SIZE	EACH	12/EA
A57659-1006	6-3/4"	\$5.61	\$5.04
A57659-1008	8-1/4"	6.73	6.05



6"

Maped® Ultimate Precision Scissors

Very sharp pointed tips are ideal for precise cutting jobs. Premium stainless steel blades are paired with a soft, double-ring handle that eliminates painful pressure while cutting. Manufacturer's lifetime warranty.

NUMBER	DESCRIPTION	SIZE	EACH	12/EA
A58470-1005	Universal	5"	\$5.03	\$4.50
A56642-1007	Right Hand	7"	6.76	6.08
A56642-1008	Right Hand	8-1/4"	7.89	7.10



6"

Vantage™ Comfort Grip Scissors

These ergonomically correct shears reduce fatigue, and the double ground blades offer precise cutting of thicker material. Great for home, office, and craft, Comfort Grip Scissors can cut easily through paper, fabric, and cardstock.

NUMBER	SIZE	EACH	12/EA
A57076-1005	5"	\$10.23	\$9.21
A57076-1006	6"	13.22	11.89
A57076-1008	8"	14.59	13.13

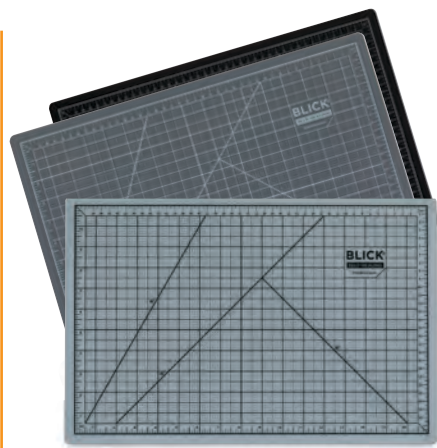

Blick® Self-Healing Cutting Mats

Made of high-tech, 3-ply polymer, with a self-healing surface that holds up under repeated use. Calibrated inch grid lines make cutting easy. 45° and 60° angled lines are helpful for making diagonal cuts.

Black/Gray — Double sided.

NUMBER	SIZE	EACH	12/EA
A57559-2585	8-1/2" x 11"	\$5.70	\$5.15
A57559-2506	12" x 18"	10.65	9.59
A57559-2509	18" x 24"	18.99	17.09
A57539-2436	24" x 36"	37.47	33.73

Translucent

NUMBER	SIZE	EACH	12/EA
A58991-1085	8-1/2" x 11"	\$5.94	\$5.34
A58991-1006	12" x 18"	11.43	10.27
A58991-1009	18" x 24"	20.57	18.49
A58991-1015	24" x 36"	40.24	36.17

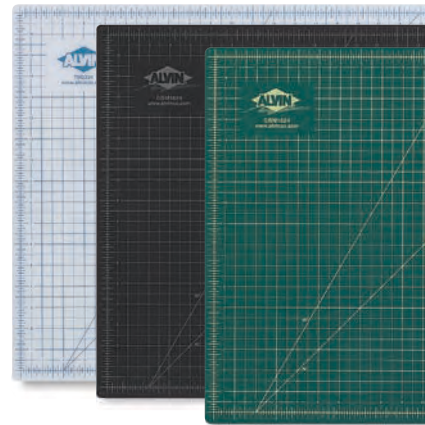

Alvin® Professional Self-Healing Cutting Mats

Made with a resilient, 3-ply vinyl that heals so completely it can be used as a writing/drawing surface, even over previously cut lines. Green/Black double-sided mats are marked with a 1/2" grid pattern, angled lines, and 1/4" gradations. Non-slip, non-glare.

Green/Black

NUMBER	SIZE	EACH
A57522-7506	12" x 18"	\$19.06
A57522-7509	18" x 24"	36.43
A57522-7515	24" x 36"	72.93
A57522-7507	30" x 42"	149.33
A57522-7527	36" x 48"	191.99
AF57518-7080	40" x 80"	355.00

Translucent

NUMBER	SIZE	EACH
A58910-1003	8-1/2" x 12"	\$12.53
A58910-1006	12" x 18"	24.11
A58910-1009	18" x 24"	47.35
A58910-1005	24" x 36"	91.99
A58910-1106	30" x 42"	186.90
A58910-1007	36" x 48"	213.05



Dahle® Self-Healing Cutting Mats

Five layers of PVC gives these mats maximum self-healing capability and prolonged life. Surface material keeps cutting blades from becoming dull. Each mat contains inch and metric measurements, angled lines on the top surface, and 1/2" grid lines. An excellent work surface for cutting, drawing, and sewing. Use either side for cutting. More sizes online.

Black

NUMBER	SIZE	EACH	12/EA
A58983-2053	9" x 12"	\$8.79	\$7.91
A58983-2056	12" x 18"	15.75	14.17
A58983-2059	18" x 24"	22.05	19.83
A58983-2055	24" x 36"	40.87	36.79
A58983-2057	36" x 48"	92.28	83.05

Blue

NUMBER	SIZE	EACH	12/EA
A58983-4863	9" x 12"	\$8.79	\$7.91
A58983-4866	12" x 18"	15.75	14.17
A58983-4869	18" x 24"	22.05	19.83
A58983-4865	24" x 36"	40.87	36.79
A58983-4860	36" x 48"	92.28	83.05

Clear

NUMBER	SIZE	EACH	12/EA
A58983-1023	9" x 12"	\$12.70	\$11.43
A58983-1006	12" x 18"	22.44	20.19
A58983-1009	18" x 24"	35.14	31.63
A58983-1015	24" x 36"	54.83	49.35

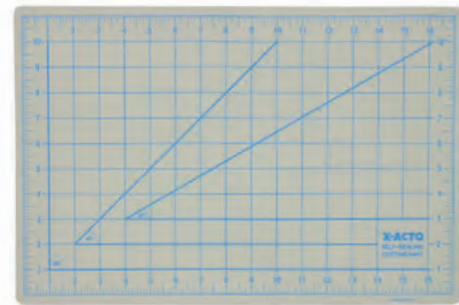

X-Acto® Self-Healing Mats

These gray self-healing cutting surfaces won't disintegrate with repeated use. Make clean, straight cuts every time. A one-inch incremented grid pattern aids in sizing your cuts.

NUMBER	SIZE	EACH	12/EA
A58900-2516	12" x 18"	\$34.30	\$30.87
A58900-2519	18" x 24"	50.58	45.52
A58900-2515	24" x 36"	94.81	85.33



E X-Acto® #1 Precision Retractable Blade™ Knife

This knife is perfect for delicate, precision cutting and trimming of paper, plastic, balsa, thin metal, cloth, and film. A soft triangular comfort grip covers the knife's metal core, and an anti-roll handle keeps it from rolling off work surfaces.

NUMBER	EACH	12/EA
A57528-1001	\$11.24	\$10.12

D X-Acto® Gripster Knife

Features a rubberized barrel for comfort and control and an anti-roll stop. Rear blade release makes blade changing safer, easier, and faster. Knife comes with a #11 Standard blade and a cap.

NUMBER	EACH	12/EA
A57420-2050	\$8.32	\$7.49

A X-Acto® #1 Knife

For delicate precision cutting and trimming. Knife has an aluminum handle and comes with a #11 Standard blade and safety cap.

NUMBER	EACH	12/EA
A57445-1101	\$4.45	\$3.99

X-Acto® #1 Knife Set

Includes one #1 Knife with a #11 blade attached, plus two additional #11 blades, a #10 blade, a #16 blade, and a #17 blade (six blades total).

NUMBER	EACH	12/EA
A57450-0051	\$8.71	\$7.84

B X-Acto® #2 Knife

For making precise, accurate cuts through a variety of materials. Knife has an aluminum handle and comes with a #2 Standard blade.

NUMBER	EACH	12/EA
A57411-1002	\$6.32	\$5.69
A57497-1002	7.55	6.79

C X-Acto® Z-Series #1 Knife

The Z-Series is X-Acto's sharpest, most durable precision knife system to date. Knife has an aluminum handle and comes with a #11 Z-Series blade.

NUMBER	DESCRIPTION	EACH	12/EA
A57558-1001	Z Series Knife	\$5.89	\$5.31

Number	Blade	Z-Series Knife	#1 Knife	#2 Knife	Gripster Knife	Uses and Features
Standard						
2				✓		Larger version of the #11 blade; sharp angle for precision cutting of medium to heavyweight materials.
10		✓	✓		✓	For general cutting, carving, and correcting stencils.
11		✓	✓		✓	Sharp point for fine angle cutting and stripping.
28				✓		Hooked for curved shaping, whittling, leather carving, and lino cutting.
Z-Series						
11		✓	✓		✓	X-Acto's sharpest blade; for fine angle cutting and stripping.
X-Life						
11		✓	✓		✓	Extremely sharp point for fine angle cutting and stripping.
16		✓	✓		✓	For stenciling, scoring, and etching lightweight materials.

X-Acto® Standard Blades

Strong blades crafted with sharpened high-carbon steel (unless noted) for a reliable cut.

NUMBER	STYLE #	PKG OF	EACH	12/EA
A57413-1102	2	5	\$3.98	\$3.58
A57413-1002	2	100	52.39	46.99
A57413-1005	10	5	5.65	5.08
A57493-1011	11	100	44.64	40.17
A57413-1411	11	5, Stainless Steel	4.14	3.72
A57413-1111	11	100, Stainless Steel	54.76	49.14
A57413-1711	11	40	19.31	17.38
A57413-1028	28	5	19.30	17.35

X-Acto® Z-Series Blades

Designed to be the absolute "best in class," Z-Series Blades are seven to 10 times sharper than standard X-Acto blades. A zirconium nitride coating on the cutting edge adds significant strength, particularly at the tip.

NUMBER	STYLE #	PKG OF	EACH	12/EA
A57558-1105	11	5	\$4.37	\$3.92
A57558-1100	11	100	56.31	50.68

X-Acto® X-Life™ Blades

Long-lasting and extra sharp, X-Life Blades are made from high-carbon steel with an oxide coating to prevent rust and increase durability.

NUMBER	STYLE #	PKG OF	EACH	10/EA
A57413-1011	11	100	\$37.34	\$33.51
A57413-1211	11	500	148.14	133.34
A57413-1016	16	100	36.32	32.60

X-Acto® Blade Safety Dispenser

Extremely useful for hobbyists, artists, and graphics professionals who need to keep a small stock of replacements safely on hand. Each dispenser comes with 15 blades.

NUMBER	STYLE #	PKG OF	EACH	12/EA
A57489-1021	#11, Stainless Steel	15	\$12.43	\$11.19



X-Acto® Basic Knife Set with Case

Includes #1, #2, and #5 knives and #2, #7, #10, #11, #16, #17, #18, #19, #22, and #24 blades in a premium, soft-body case — great for organization, travel, and storage.

NUMBER	EACH	3/EA
A56692-1000	\$33.92	\$30.52



Blick® Studio E-Z Grip Knife
The longtime favorite of hobbyists, technicians, and graphic arts professionals. It features a red, fatigue-reducing cushion grip handle, rear release, anti-roll design, and safer blade changing. Square nut at the base of the barrel prevents the knife from rolling down slanted surfaces. Comes with a plastic tube for storage. Accepts #11 and #16 blades.

NUMBER	EACH	12/EA	24/EA
A57419-2980	\$4.95	\$4.45	\$4.23



Blick® Premier Precision Art Knife
A textured rubber grip makes our exclusive knife more comfortable, accurate, and safe to maneuver. Plus the honed Japanese steel blades are sharper than other brands and stay that way longer. Impact-resistant ABS plastic handle includes blade storage compartment and safety cap. 16 blades included.

NUMBER	DESCRIPTION	EACH	12/EA
A57537-2916	Knife	\$7.67	\$6.90
A57537-1048	Blades, 48-Pack	7.67	6.90



Blick® Premier Snap-Off Knife
Our exclusive, premier-quality knife features high-tempered Japanese black steel blades that retain their sharpness longer than other brands. Built-in blade snapper makes removing dull blades safe and convenient. Lightweight, impact-resistant ABS plastic handle has an auto safety lock that holds the blade securely in place while cutting. Includes three segmented blade units (39 blades total).

NUMBER	DESCRIPTION	EACH	12/EA
A57537-1001	Knife	\$5.50	\$4.95
A57537-1010	Blades, 10 Units (130 blades)	5.50	4.95



Blick® Premier Twist-Lock Knife
Twist lock safety mechanism holds the super-sharp, super-durable blades in place while cutting. Ergonomic, lightweight, ABS plastic handle is contoured for a comfortable, secure grip and includes blade storage. Top quality, high-tempered Japanese black steel blades. Three segmented units included (24 blades total).

NUMBER	DESCRIPTION	EACH	12/EA
A57537-2980	Knife	\$8.63	\$7.77
A57537-1005	Blades, 5 Units (40 blades)	5.78	5.21



Excel® Knives
These knives have a four-point chuck to prevent slipping and come with a safety cap. Knife and one blade are individually packaged in a plastic tube.

K1 — Aluminum handle, 6-1/4" long, with #11 blade. Takes #11 and #16 blades.

NUMBER	EACH	12/EA
A57458-1101	\$3.03	\$2.70

K2 — Aluminum handle, 6-1/4" long with #24 blade.

NUMBER	EACH	12/EA
A57458-1002	\$4.05	\$3.64

NUMBER	DESCRIPTION	EACH	6/EA
A57458-1003	Safety Caps, 25-Pack	\$8.60	\$7.75



Excel® Blades
Double-sharp, double-honed steel blades are manufactured in the USA. #11 has a fine angle for deep cuts and fits the K1 handle. #16 is a narrow-tipped blade for use with thinner materials and fits the K1 handle. #24 is a sharp angle trimmer and fits the K2 handle.

Package of 5 Blades — In a plastic safety tube.

NUMBER	DESCRIPTION	EACH	12/EA
A56449-1003	#2	\$2.95	\$2.66
A56449-1001	#11, Stainless Steel	2.95	2.66

Package of 5 Blades — In a plastic safety tube.

NUMBER	DESCRIPTION	EACH	12/EA
A57458-1011	#11	\$2.66	\$2.39
A57457-1015	#16	1.91	1.71
A57457-1005	#24	2.29	2.06

Bulk Package of 100 Blades

NUMBER	DESCRIPTION	EACH	6/EA
A56449-1004	#2	\$41.06	\$36.95
A57457-0100	#11	25.50	22.95
A56449-1002	#11, Stainless Steel	44.47	40.03
A57457-0101	#16	25.50	22.95
A57457-1001	#24	30.73	27.65



Knife Grips
Designed by physicians to help stop writing fatigue, these colorful, soft rubber grips can also help small fingers hold tight. Fits over most X-Acto and hobby knives. Assorted colors. Sold individually.

NUMBER	EACH	12/EA	24/EA
A22954-1000	\$2.31	\$2.08	\$1.97



Excel® Cushion Grip Knife
These 5" long precision knives are highly versatile. Each includes a #11 double-honed blade and a special screw for added blade security and stabilization. Perfect for detailed paper cutting, trimming card stock and rubber, and stripping paper, they can also cut through foam, plastic, wood, polymer clay, and cork.

Excel® Cushion Grip Knife

NUMBER	COLOR	EACH	12/EA
A86400-2020	Black	\$5.09	\$4.60
A86400-5010	Blue	5.09	4.60
A86400-7010	Green	5.09	4.60
A86400-6000	Purple	5.09	4.60



Fiskars® Softgrip Ergonomic Detail Knife
Cut through cardstock, rubber, foam board, wood, plastic, and more comfortably for long periods of time. This knife has a rubberized, ergonomic, soft cushion grip and features a #11 blade, shatter-resistant, twist-lock safety cap, and four-jaw aluminum chuck.

NUMBER	COLOR	EACH	12/EA
A86401-2020	Black	\$7.62	\$6.85
A86401-7010	Green	7.62	6.85



Fiskars® Softgrip Ergonomic Detail Knife
The ergonomic handle provides excellent control. SoftGrip design means hours of fatigue-free use. Uses standard #11 replacement blades and features a protective plastic sheath for safe storage and transport.

NUMBER	EACH	12/EA
A57517-4860	\$7.35	\$6.61

Helpful for individuals with special needs.



Slice® Ceramic Craft Knife
Ideal for precision cutting and scraping, this craft knife features a strong, durable ceramic safety blade. With a patented finger-friendly edge, the blade cuts through contact paper, cardstock, felt, duct tape, and more with ease but resists cutting skin. Ambidextrous, no-roll design. Includes one blade and a cap for safe storage.

NUMBER	DESCRIPTION	EACH
A56447-1001	Knife	\$14.19
A56447-1002	Blades, 4-Pack, Straight	23.09
A56447-1003	Blades, 4-Pack, Pointed	23.09



Slice™ Ceramic Precision Cutter
Cut intricate designs and detailed patterns in paper and other thin materials. This knife has an oval non-roll design and a durable, anti-slip handle. The micro-ceramic blade lasts longer than metal blades, and won't cut fingers. Includes a safety cap. No tools needed for blade changes. Approximately 7-1/4" x 3".

NUMBER	EACH
A57527-1050	\$9.89



Slice® Manual Utility Knife
With a patented finger-friendly ceramic blade that cuts materials effectively but resists cutting skin, this utility knife is safe, durable, and versatile. Blade (included) adjusts to five different positions, extending up to 1" long.

NUMBER	DESCRIPTION	EACH
A56448-1001	Knife	\$25.34
A56448-1002	Blades, 3-Pack	22.03

WARNING! Products marked with a Prop 65 symbol (■ or ▼) can expose you to chemicals, including cadmium, which are known to the State of California to cause cancer and birth defects or other reproductive harm. For more information, visit P65Warnings.ca.gov.



Slice® Manual Utility Ceramic Scraper
Scrape paint, rust, and adhesives in comfort. This scraper features an ambidextrous, ergonomic handle with soft-touch finger grips. Its round-tip ceramic utility blade is safe to touch, yet just as effective and more durable than traditional blades. The handle has two preset blade positions, a convenient, built-in lanyard hole, and tool-free blade change.

NUMBER	EACH
A35397-1001	\$21.19



Slice Pen Cutter

NUMBER	EACH
A56441-1001	\$14.29



Slice Replacement Blades
These double-sided knife blades are made of 100% zirconium oxide and stay sharp up to 11x longer than steel. They feature rounded tips for protection and can be reversed to refresh the edge. They are non-sparking, non-magnetic, and don't rust. Set of 4.

NUMBER	DESCRIPTION	EACH
A57527-1040	Rounded	\$21.99
A57527-1060	Pointed	21.99



X-Acto® Surgrip Retractable Utility Knife
Features a retractable blade that cuts through paper, cardboard, matboard, sheet metal, and plastic, as well as delicate fabrics. The ergonomic metal handle assures a firm, comfortable grip while cutting.

NUMBER	EACH	12/EA
A57497-1020	\$12.58	\$11.32



Excel® Hobby Handheld Scraper
Trim, cut, and scrape with this handy metal tool. Uses ordinary single-edge razor blades. Push-button safety retracts blade when not in use. Comes with five blades.

NUMBER	EACH	6/EA
A57428-0000	\$5.70	\$5.13

Replacement Blades

NUMBER	DESCRIPTION	EACH	10/EA
A57407-1010	10 Pack	\$2.59	\$2.33
A57407-1100	100 Pack	11.39	10.25



Excel® Smart Snap Knife
This sturdy plastic knife handle includes one strip of seven 30° snap utility knife blades. When the blade becomes dull, snap it off to reveal a sharper blade. Cut through foam board, vinyl, paper, wood, plastic, fondant, and more. It also has a rounded edge for seamless angle transitions.

NUMBER	COLOR	EACH	6/EA
A86402-5010	Blue	\$3.47	\$3.13
A86402-3060	Pink	3.47	3.13

Replacement Blades

NUMBER	EACH	6/EA
A86404-1001	\$9.45	\$8.50



Olfa® SNAPit 'N' TRAPit PRO Heavy-Duty Snap-Off Knife
Performance and functionality combine in this versatile knife from Olfa. The premium blade snaps off as needed, and the heavy-duty ABS plastic container traps up to 26 blade segments.

NUMBER	DESCRIPTION	EACH	12/EA
A57426-0000	18 mm Knife	10.58	9.53
A57426-1005	18 mm Refill Blades, 5-Pack	6.85	6.16



A Fiskars® SureCut™ Portable Paper Trimmer

Cut on the go. Lightweight and portable, the 9" trimmer has a binder-friendly design with holes built into the base. The SureCut wire cut-line shows you exactly where the blade will cut, ensuring perfect placement. Cut up to eight sheets of paper at once. For details, visit DickBlick.com.

NUMBER	DESCRIPTION	EACH	6/EA
A56893-1001	9" Cut	\$18.28	\$16.45
A56893-1002	12" Cut	26.28	23.65
A56893-1003	Replacement Blade	7.88	7.09

B Carl™ Professional Rotary Trimmer

Count on precise, professional-quality cuts every time. This trimmer's premium carbide blade easily shears through 10 sheets of standard 20 lb bond paper at once, making short work of extensive trimming projects. The stable metal base is calibrated for accuracy and features updated graphics, rulers, and a grid with preset measurements for common-sized items.

NUMBER	DESCRIPTION	EACH	6/EA
A57191-1012	12" Cut	\$58.25	\$52.42
A57191-1018	18" Cut	88.18	79.36
A57195-1001	Replacement Blade	8.85	7.96

C Westcott® CarboTitanium® Rotary Trimmer

This rotary trimmer has a blade that is eight times harder than steel, and the unique lever design allows for a clean cut of 10 sheets of 20 lb paper at one time. The measuring grid includes inch and metric grid markings. Secure locks at each end of the cutting rail hold paper in place for straighter cuts. Extra replacement blades can be stored in the included compartment.

NUMBER	DESCRIPTION	EACH	6/EA
A56895-1015	15"	\$128.24	\$115.40
A56895-1001	Replacement Blades, 2-Pack	26.56	23.90

D Carl™ Green Machine Heavy-Duty Rotary Trimmer

The Green Machine is made from 45% recycled content. Cuts through up to 36 sheets of standard 20 lb paper, plus cardstock, plastic sheeting, photographs, mat board, and foam board up to 1/8" thick. Patented locking rail mechanism holds materials firmly in place. Luminous Paper Holder makes cutting easier and more accurate. Calibrated metal base has a built-in storage compartment. Spare cutting mat and extra blades included. Limited lifetime warranty.

NUMBER	DESCRIPTION	EACH	6/EA
A57192-1012	12" Cut	\$202.09	\$181.88
A57192-1015	15" Cut	227.08	204.37
A57192-1018	18" Cut	253.54	228.18
A57192-2028	Straight Replacement Blades, 2-Pack	14.53	13.08
A57192-2031	Perforating Replacement Blades, 2-Pack	14.53	13.08

E Rotatrim Professional Series Cutter

Accurately cuts film, laminated materials, and digital media output from image setters and plotters. An ergonomic die-cast steel housing over the cutting wheel ensures safety. Includes a screen printed grid with inches and metrics, a 12" rule with adjustable squaring arm, and a spare clear plastic clamp strip. Five-year guarantee. FOB Factory. See page 648 for details.

NUMBER	SIZE	EACH
AF57179-1012	12" Cut	\$291.48
AF57179-1015	15" Cut	329.00
AF57179-1018	18" Cut	360.00
AF57179-1020	20" Cut	387.00
AF57179-1024	24" Cut	419.00
AF57179-1030	30" Cut	519.00
AF57179-1036	36" Cut	593.00
AF57179-1042	42" Cut	678.00
AF57179-1054	54" Cut	795.00

Replacement Cutting Wheel — FOB Factory. See page 648 for details.

NUMBER	EACH
AF57179-1001	\$79.48

F Dahle® Rolling Trimmer

Fast, simple, and accurate cutting and trimming of single or stacked paper sheets, photos, and film. A see-through plastic clamp holds paper. Cut in either direction by moving the plastic housing containing the rotating circular blade. The wheel is ground, self-sharpening, and replaceable. Cuts up to five sheets. Standard photo formats are printed on metal base. Scale bars are shown in inches and centimeters.

NUMBER	SIZE	EACH
A57130-1012	12" Metal Base	\$66.99
A57130-1018	18" Metal Base	78.53
A57130-9000	Replacement Blade Head	28.06

G Dahle® Professional Series Guillotine Trimmer

A professional-quality guillotine at a value price. Designed for heavier applications, it cuts up to 15 sheets of paper, as well as cardstock and illustration paper. The Solingen steel blade is self-sharpening and provides a clean, burr-free cut every time. For added versatility, the paper guide can be mounted on either side of the base. Limited lifetime warranty. FOB Factory. See page 648 for details.

NUMBER	SIZE	EACH
AF57183-1012	12" Cut	\$156.35
AF57183-1018	18" Cut	220.48

H Dahle® Professional Rolling Trimmers

These precision trimmers make 1/16" wide trims on paper, film, foil, and cardboard. Cuts up to 10 sheets at once. Self-sharpening, completely enclosed, German steel cutting wheel. Cutting assembly rides on polished steel guide rail and engages automatic gripping clamp to ensure clean, uniform cuts. Metallic right-angle ruler with inch and metric calibrations. FOB Factory. See page 648 for details.

NUMBER	SIZE	EACH
AF57104-1014	14-1/8" Cut	\$201.25
AF57104-1018	20-1/8" Cut	263.08
AF57104-1026	28-1/4" Cut	361.00
AF57104-1038	37-1/2" Cut	445.00
AF57104-9003	51" Cut	552.00

Stands — Maximize floor space while providing an optimal, comfortable height for trimming.

NUMBER	DESCRIPTION	EACH
A57197-5560	Stand for 37-1/2" Cut	\$572.00
AF57104-1051	Stand for 51" Cut	678.00

I Dahle® Premium Rolling Trimmer

Thicker materials like matboard and stacked paper are easily cut by this high-capacity, premium rolling trimmer. Its ground, self-sharpening, replaceable circular blade cuts with precision in either direction. A plastic safety housing protects against injury. The sturdy metal base includes both inch and metric scales and an automatic see-through paper clamp. FOB Factory. See page 648 for details.

NUMBER	DESCRIPTION	SIZE	EACH
AF57135-1408	Trimmer	14-1/4" Cut	\$315.00
AF57135-2008	Trimmer	20-1/8" Cut	431.00
AF57135-0000	Trimmer	26-3/8" Cut	544.00
AF57135-3604	Trimmer	36-1/4" Cut	716.00
AF57135-5108	Trimmer	51-1/8" Cut	807.00
AF57135-1072	Trimmer	72" Cut	1473.00
AF57135-3614	Trimmer with Stand	36-1/4" Cut	1349.00
AF57135-5118	Trimmer with Stand	51-1/8" Cut	1547.00

J Dahle® Premium Series Large Format Guillotine Trimmer with Stand

A professional-quality cutter perfect for shops or art rooms. It's equipped with a ground, self-sharpening Solingen steel blade, which easily cuts thick materials or as many as 30 sheets of paper at a time. It's permanently affixed to a metal stand, which ensures the proper cutting height. A shelf provides additional storage. For more details, visit DickBlick.com. FOB Factory. See page 648 for details.

NUMBER	SIZE	WEIGHT	EACH
AF57184-1032	32" Cut	160 lb	\$2732.00
AF57184-1035	43" Cut	230 lb	4340.00

DAHLE®



Large Format Guillotine Trimmer

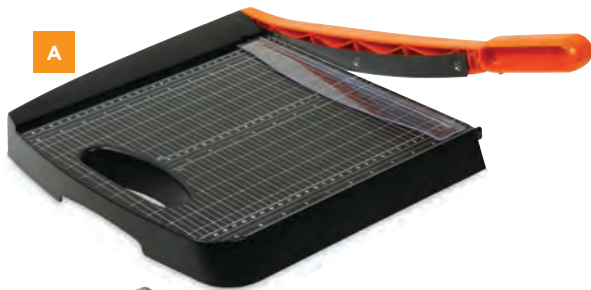

A

A Fiskars® Recycled Bypass Paper Trimmer

Ideal for cutting heavier materials, this paper trimmer cuts up to 10 sheets of 20 lb paper at one time. Its self-sharpening blades never need replacing, and a precision printed 12" scale and grid allows users to accurately align projects before cutting. The trimmer base is made from 100% recycled post-consumer resin.

NUMBER	SIZE	EACH
A57182-2012	12"	\$49.59



B

B Dahle® Vantage® Paper Trimmer

This value-priced paper trimmer has a sturdy metal base with non-skid rubber feet. Features a spring-action metal blade with an automatic paper clamp. Measures in metric and inches with a pre-printed grid for easy sizing of paper.

NUMBER	SIZE	EACH
A57134-1012	12" Cut	\$86.83
A57134-1015	15" Cut	101.57
A57134-1018	18" Cut	115.42

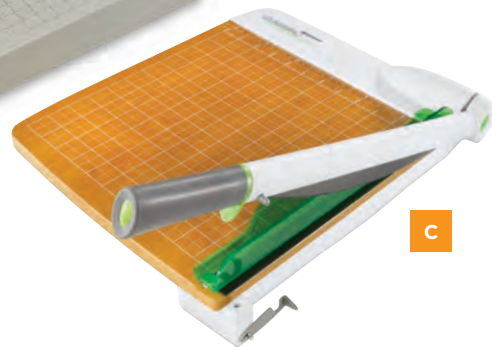

C

C Westcott® CarboTitanium® Guillotine Paper Trimmer

Designed for precision and maximum performance, this trimmer is perfect for all your classroom, home, and craft needs. Its heavy-duty CarboTitanium blade is eight times harder than steel and cuts up to 30 sheets of 20 lb paper at once. A finger rest keeps fingers safely away from the cutting area, and a safety latch locks the handle in place when not in use.

NUMBER	SIZE	EACH
A58365-1012	12" Cut	\$92.67
A58365-1015	15" Cut	132.41
A58365-1018	18" Cut	191.22



D

D X-Acto® Heavy-Duty Wood Trimmer

Features a self-sharpening hardened steel blade that can cut 15 sheets of 20 lb paper cleanly. Adjustable sliding paper guide locks for perfect alignment, while the precision ruled inch and metric scales make accurate measuring simple. Easy-grip handle makes cutting comfortable. Heavy wooden base has rubber feet to prevent sliding and protects your work surface. Safety guard conceals the blade edge. Safety lock secures the blade when not in use.

NUMBER	SIZE	EACH
A57100-1012	12" Cut	\$113.18
A57100-1015	15" Cut	136.21
A57100-1018	18" Cut	180.45
A57100-1024	24" Cut	226.99



E

E X-Acto® Heavy-Duty Square Trimmer

This rugged wooden trimmer was designed for heavy-duty commercial and school environments and features the X-Acto hardened steel blade and Perpetual Edge Self-Sharpener System. Sturdy 3/4" thick square wood base rests on solid wood supports with non-skid feet. Safety features include self-locking safety latch and finger guard. American and metric grids for precision measuring and cutting.

NUMBER	SIZE	EACH
A57149-1015	15" Cut	\$183.57
A57149-1018	18" Cut	225.99
A57149-1024	24" Cut	296.27



F

F GBC® Classiccut™ Ingento® Maple Trimmers

These classic paper cutters are designed for heavy cutting, with self-sharpening, bevel-ground, tempered steel blades. For safety, all feature a tension spring and guard rail. The hardwood surface is scored in half-inch squares. The 24" and 30" models do not qualify for free shipping offer. See exceptions on page 648. *Truck Shipment and FOB Factory. See page 648 for details.

NUMBER	SIZE	EACH
A57108-1004	12" Cut	\$193.93
A57108-1007	15" Cut	258.99
A57108-1008	18" Cut	270.17
A57108-1002	24" Cut	390.00
A57108-1005	*30" Cut	619.00

G Martin Yale® PolyBoard™ Trimmer

Precision cutting has never been so simple and safe. This trimmer features maintenance-free stainless steel blades that slice through up to 10 sheets at once. The unbreakable molded base stands up to heavy use, making it perfect for busy classrooms, shops, and studios. Safety features include a patented automatic blade latch, finger guard, and torsion spring. The base is marked with a 1/2" grid and metric rulers for proper alignment. Non-skid rubber feet provide extra control and grip.

NUMBER	SIZE	EACH
A57132-1012	12" Cut	\$87.70
A57132-1015	15" Cut	92.33
A57132-1018	18" Cut	180.96



G

H Martin Yale® Premier® Heavy-Duty Trimmers

Cut paper, film, fabric, foil, mat board, and more. Replaceable, self-sharpening, hardened, tool-steel blades. Bright red safety guard rail protects fingers. Safety spring keeps ergonomic soft-grip handle from falling. Lock holds handle in place when not in use. Slide guide for uniform trimming. 3/4" thick wood base has permanent 1/2" grid and dual English and metric rulers to ensure correct alignment. *Truck Shipment and FOB Factory. See page 648 for details.

NUMBER	SIZE	EACH
A57157-1012	12" Cut	\$167.27
A57157-1015	15" Cut	240.55
A57102-1018	18" Cut	248.17
A57102-1024	24" Cut	320.00
AF57172-7030	*30" Cut	525.00
AF57172-7036	*36" Cut w/Auto Clamp	655.00

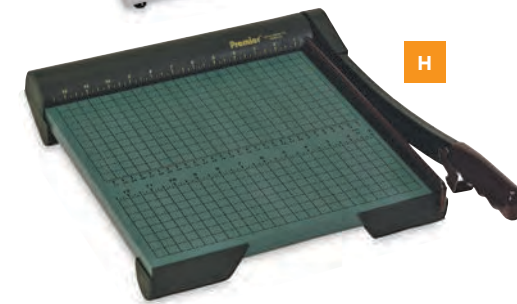

H

I Martin Yale® Premier® StakCut™ Green Board Paper Trimmer

A strong 3/4" thick wood base positions and steadies paper (up to 30 sheets), as well as mat board, cardboard, film, tissue, or textiles. The precision-angled steel blade delivers accurate cuts time after time. An ergonomic soft-grip handle keeps hands comfortable during those big cutting jobs, and a finger guard protects along the entire length of the blade for added safety. FOB Factory. See page 648 for details.

NUMBER	SIZE	EACH
AF57176-1015	15" Cut	\$251.99
AF57176-1024	24" Cut	375.00

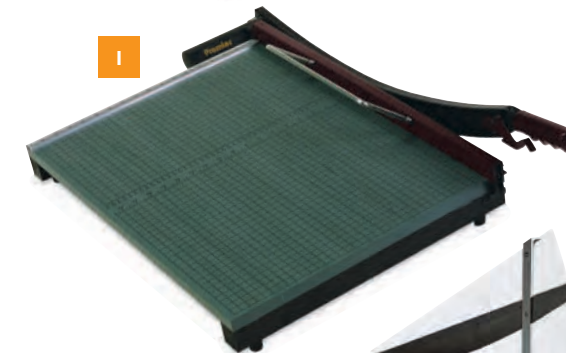

I

J Kuttrimmer™ Trimming Boards

These sturdy paper cutters will cut 40–50 sheets in one operation. They are safer, more accurate, and more efficient than any we've seen. All models of the Kuttrimmer will cut paper, cardboard, fiberboard, foils, vinyls, rubber, fabrics, leather, linoleum, felt, thin plywood, thin soft metal, and various specialty materials. Solidly built heavy-gauge welded steel construction with Plexiglas® blade shield. Adjustable alignment bar sets length or width of cut. Standing models have a foot-operated clamp and a lock and key to prevent unauthorized use. Truck Shipment and FOB Factory. See page 648 for details.

Table Models		EACH
NUMBER	SIZE	
AF57111-1023	21-1/2" Cut	\$970.00
AF57111-1029	28-1/2" Cut	1189.00

Floor Models — Truck Shipment and FOB Factory. See page 648 for details.		EACH
NUMBER	SIZE	
AF57111-1032	31-1/4" Cut	\$2074.00
AF57111-1044	43-3/4" Cut	3001.00



J

Floor Model

K GBC® Classiccut™ Ingento® Maple Table Trimmers

36" x 30" With Hold-Down Bar — Heavy-duty cutting assembly mounted on sturdy wooden table with drop shelf and storage shelf. Scored 36" x 30" top. Foot-operated hold-down bar keeps edges straight and fingers away. Does not qualify for free shipping offer. See exceptions on page 648. Truck Shipment and FOB Factory. See page 648 for details.

NUMBER	EACH
AF57107-1006	\$1230.00

30" x 30" Without Hold-Down Bar — Same construction as table above but without the foot-operated hold-down bar. 30" x 30" top, not scored. Packed flat, easily set up. Some assembly required. Does not qualify for free shipping offer. See exceptions on page 648. Truck Shipment and FOB Factory. See page 648 for details.

NUMBER	EACH
AF57107-1005	\$990.00



K

BLICK® tabletop easels



A

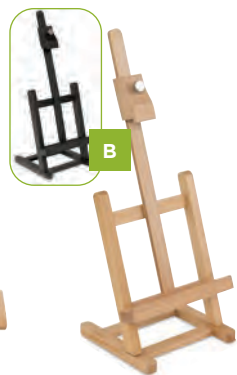

B



C



D



E



F



G



H



A Blick® Studio Tabletop Display Easel

Perfect for holding lightweight canvases, photographs, and signs up to 22" high. Crafted of hand-sanded hardwood with rubber feet for stability. 13"W x 16"D. Weighs 1 lb.

NUMBER	COLOR	EACH	10/EA
A50620-8540	Natural	\$11.75	\$10.57
A50620-2020	Black	11.75	10.57

B Blick® Studio Mini Tabletop Easel

Ideal for small-scale painting or displaying finished artwork, photographs, awards, and signs up to 12" high. Crafted of smooth, sanded hardwood, the base measures 6"W x 6-1/4"D and the easel shelf 6-1/2"W. Weighs 12 oz.

NUMBER	COLOR	EACH	10/EA
A50391-1001	Natural	\$13.29	\$11.99
A50391-1007	Black	13.29	11.99

C Blick® Studio Sketchbox Table Easel

A high-quality, beautifully crafted, portable studio for artists on the go. The easel tilts back to any angle from 0-90°. Versatile, independently adjustable carriages hold a canvas or panel up to 34" high. Locking storage drawer has four compartments. Measures 4-1/2"H x 16-1/2"W x 15"D. Weighs 9.2 lb.

NUMBER	EACH	10/EA
A50391-1003	\$86.57	\$77.91

D Blick® Studio Tabletop Easel

This easel may be small, but it's designed for serious work. Crafted of smooth, sanded hardwood, it tilts back for painting, forward for pastel work. The base measures 11"W x 12-1/2"D. Holds canvas and panels up to 22" high. Folds flat for storage. Weighs 3 lb.

NUMBER	COLOR	EACH	10/EA
A50391-1002	Natural	\$41.95	\$37.75
A50391-1006	Black	41.95	37.75

E Blick® Studio Book Stand Easel

A tabletop easel and book stand in one. Use it to prop up canvas, panels, books, tablets, and other items up to 14" wide. Two page holders keep your place and a center cutout accommodates a tablet charger. Incline adjusts to three positions. Folds flat (13-1/4" x 9-1/4" x 3/4") for easy storage and transport. Weighs 2.2 lb.

NUMBER	EACH	10/EA
A50391-1005	\$19.71	\$17.75

F Blick® Studio Desk Easel

A mini studio for your home or on the go. This portable, solid pine sketchbox easel features four incline positions. Use it to prop up canvas, panels, books, and other media up to 14" wide. Includes a locking drawer, carry handle, and wooden palette. Measures 13-1/4" x 4-1/4" x 3" when closed. Weighs 2.5 lb.

NUMBER	EACH	10/EA
A50391-1004	\$17.69	\$15.92

G Blick® Studio Aluminum Tabletop Easel

Highly functional, portable, and stable, this easel is ideal for small spaces and temporary setups. Crafted of sturdy, lightweight aluminum, it holds canvases and panels up to 24" high. Non-skid feet add stability and protect table surfaces. Folds easily for storage. 30"H x 18"W x 12"D overall. Weighs 3 lb.

NUMBER	EACH	10/EA
A51752-2930	\$35.06	\$31.55

H Blick® Studio Aluminum Table Easel by Jullian®

Hinged bottom shelf opens instantly, snaps closed. Adjustable wings fold out to support canvas up to 24" high. Sturdy 1/2" aluminum tubing with rubber tips on legs holds easel firmly in place. Folds neatly for storage and travel. Measures 17"H x 17-1/2"W x 13"D and weighs 2 lb.

NUMBER	EACH	12/EA
A50393-1011	\$13.65	\$12.29



I

J



K



L



M



N

O



P

Q



I Economy Table Easel

Manufactured with quality, durability, and economy in mind. Comparable to the more expensive easels in many ways: has a wide-ribbed canvas tray that adjusts easily, multi-tilt options, and non-skid rubber tips. 12" easel weighs 0.6 lb and the 24" easel weighs 1.1 lb. Made of pine.

NUMBER	HEIGHT	EACH	12/EA
A50303-1012	12"	\$17.82	\$16.04
A50303-1024	24"	24.05	21.65

J American Easel Tabletop Easel

This small yet versatile easel is great for sketching, painting, or displaying your work. Made of high-quality fir, it will accept stain, paint, or any finish. Folds flat for easy storage. 18-1/2"H with a 17"W x 14"D overall. Made in the USA. Weighs 3.5 lb.

NUMBER	EACH	3/EA
A50359-1001	\$42.05	\$37.86

K Compact Table Easel

Despite its small size, it can hold a canvas up to 27-1/2" high. The folding design is great for both travel and storage. Made of oiled beechwood. 30"H x 26"W x 15"D overall. Weighs 1.4 lb.

NUMBER	EACH	12/EA
A50512-1040	\$23.73	\$21.36

L Jullian® Art Drawing Board

Made of oiled beechwood, this drawing board adjusts to five angled positions. An adjustable canvas carrying strap makes the board easy to take along for drawing on location, in class, or at work. Measures 25" x 20" with a full length pencil tray. Weighs 7.7 lb.

NUMBER	EACH	6/EA
A50579-1001	\$62.25	\$55.99

M Elm Tabletop Easel

Constructed of varnished elm, this versatile tabletop easel holds canvases up to 24" high yet folds flat to a mere 10" x 17" x 2" for easy transport and storage. Weighs 3 lb.

NUMBER	EACH	10/EA
A50368-1001	\$20.06	\$18.05

N Nestrite® Deluxe Folding Easel

Folding easel is equipped with an adjustable 18" steel extension bar and sturdy canvas clamp assembly. Securely holds a canvas as large as 32"H x 40"W. Weighs 14 oz.

NUMBER	EACH	6/EA
A50309-0100	\$39.95	\$35.95

O Locking Aluminum Table Easel

Locking mechanism holds canvases securely, letting you carry your paintings on the easel whether wet or dry. Accommodates artwork up to 20" high. Hinged shelf. 23-1/2"H x 19"W x 14-24"D overall. Weighs 1.5 lb.

NUMBER	EACH	12/EA
A50512-1020	\$33.74	\$30.37

P Metal Table Sketching Easel

Equipped with adjustable "wings" that support large materials, this easel is lightweight, compact, and very portable. Great for sketching anywhere and everywhere, it holds a board or pad up to 22" high. Includes satchel. 22"H x 14"W x 14"D overall. Weighs 1 lb.

NUMBER	EACH	12/EA
A50512-1050	\$19.53	\$17.58

Q Aluminum Table Easel

Weighing just 8 oz, this folding table easel is easy to take along on all your art adventures. Compact yet sturdy, it holds a canvas, board, or pad up to 22" high. Also great for display. 22-1/2"H x 17-1/2"W x 12"D overall.

NUMBER	EACH	12/EA
A50512-1010	\$18.05	\$16.24

DISPLAY EASELS



A

Natural

D



B

Black



C

E



Pacon® Heavy Duty Anchor Chart Paper

Heavier than the paper in traditional easel pads, this heavy-duty paper is perfect for classroom anchor charts and eliminates marker bleedthrough. Because the pages are more durable, they can be used as visual reminders of strategies, vocabulary words, and other content that students learn throughout the school year. A convenient handle makes the pads easy to transport. 25 sheets per pad.

NUMBER	DESCRIPTION	SIZE	EACH	10/EA
A10282-1034	1" Grid Ruled	27" x 34"	\$23.11	\$20.80
A10282-1134	Unruled	27" x 34"	22.87	20.58



Full Box

F



H



I



J



G

F Blick® French Easel by Jullian®
Crafted by Jullian, this classically designed French easel is a sketchbox, easel, and canvas carrier in one. Beautifully handcrafted from oiled, polished wood, it adjusts up to 73" high and holds canvas up to 34" high. The weather-resistant, metal-lined box holds a wood palette (included) and your supplies. Includes carry bag. The Full Box weighs 13 lb. The Half Box weighs 11 lb.

NUMBER	DESCRIPTION	EACH	6/EA
A51588-1001	Full Box	\$152.55	\$137.29
A51588-1002	Half Box	139.80	125.82

G Blick® Noir French Easel by Jullian®

This striking easel, sketchbox, and canvas carrier is made from premium pinewood, stained black, and varnished for durability. It features telescoping legs and a lightweight, portable design for easy transporting. It folds to a compact 22"H x 16"W x 6-1/2"D and includes a handle and linen shoulder strap. Matching black wood palette included. 73"H x 28"W x 41"D overall.

NUMBER	EACH	6/EA
A49813-2020	\$100.55	\$90.50

A Blick® Studio Folding Display Easel
Perfect for holding lightweight canvas, photographs, and signs weighing up to 5 lb. Crafted of sturdy 3/8" tubular metal. Measures 63" high and collapses to just 15" long. Weighs 4 lb.

NUMBER	EACH	10/EA
A50620-1001	\$29.26	\$26.33

B Clear Acrylic Display Easel
Made of clear acrylic, this easel puts the focus on your work. Holds artwork up to 39" high and 2" deep. Adjust the height of the shelf to five different levels by moving the acrylic pegs. 58"H x 22-3/4"W x 19-1/4"D. Weighs 13.2 lb. Assembly required.

NUMBER	EACH	10/EA
A50578-1001	\$187.61	\$168.85

C Ghent® Triumph Display Easel
With an inverted leg design that adds strength and stability, this easel is ideal for presentations, artwork, posters, and signs. Lightweight, portable, and great for tabletop use. Adjusts from 37" to 62" high. Folds down to 32"H x 4"W x 6"D. Durable ABS resin construction. Weighs 3 lb.

NUMBER	EACH	4/EA
A50613-2050	\$60.67	\$54.60

D Blick® Studio Tripod Floor Easel
A versatile easel ideal for both display or sketching on the go. The fully collapsible design measures 61-1/4"H x 34"W x 38"D and holds artwork up to 28" high. Crafted of smooth, hand-sanded hardwood in your choice of two finishes. Weighs just 2.5 lb.

NUMBER	COLOR	EACH	10/EA
A50620-8550	Natural	\$22.30	\$20.07
A50620-2050	Black	22.30	20.07

E Studio Designs™ Museum Easel
Adjustable solid wood easel with an extra-wide ledge to accommodate canvas or signage up to 48" high. Folds flat for easy transport and storage. Natural finish. 60"H x 27"W x 31"D. Weighs 7 lb.

NUMBER	EACH	10/EA
A50608-0000	\$105.54	\$94.98

Lineco® Lecturer's White Bond Pad
High-quality, unlined white bond paper. Top is firmly bound and has punched holes. The 50-sheet pad measures 27" x 34".

NUMBER	EACH	4/EA
A52924-1005	\$23.39	\$21.05





A American Easel Lyre Easel

This beautifully finished solid oak A-frame easel features a mast that adjusts up to 91" tall. The adjustable canvas holders have easy-turn knobs. Setup is easy — simply slide the mast into the mast grooves, slide on the canvas holders, then adjust the back leg to your preferred position. Overall dimensions are 68"H x 23"W x 24"D.

NUMBER	EACH	10/EA
A51593-0000	\$338.00	\$305.00

B Richeson® Dulce Easel

Enjoy perfect stability whether you're working seated or standing. The H-frame design features a laminated quad base, with a slide and lock height adjustment system. Made of eco-friendly lyptus wood, which is harder than oak and better withstands the wear and tear of everyday use. Maximum mast height 95". Base 21"W x 24"D. Weighs 28 lb.

NUMBER	EACH	10/EA
A51513-1001	\$232.99	\$220.49

C BEST™ Ultimate Easel

Fully adjustable with a double-mast, H-frame design, which provides additional stability when working large. Caster feet for mobility. Holds canvas up to 108" high. Base 24" x 30". Weighs 52 lb. FOB Factory. See page 648 for details.

NUMBER	EACH	10/EA
AF49808-1010	\$544.99	\$517.99

D American Easel Golden Oak Professional Easel

This professional-grade easel stands 82" tall and holds canvas up to 70" high. Features base supports for added stability and palette resting arms for comfortable painting. Folds flat for convenient storage. 82"H x 26"W x 21"D. Weighs 18 lb. Made in the USA. FOB Factory. See page 648 for details.

NUMBER	EACH	10/EA
AF51706-1001	\$123.99	\$117.99

E Pacific Arc Brazos Bamboo H-Frame Easel

This stunning, sturdy easel is crafted entirely of bamboo — a practical, durable, and environmentally responsible material. Easel measures 98"H x 21-1/2"W x 24-1/4"D when fully extended and holds a canvas up to 82" high. Folds for transport and storage. Minimal assembly required. Weighs 33 lb.

NUMBER	EACH	6/EA
A52891-1001	\$404.00	\$363.00

F Bamboo Lyre Easel

Made of bamboo, a renewable resource, this eco-friendly lyre easel is strong and durable. With mast extended, it has a maximum height of 90" (minimum height is 66") and holds canvas up to 50" high. It has a base footprint of 27" x 33" when open. Weighs 15 lb. Directions included for easy assembly.

NUMBER	EACH	10/EA
A51734-1001	\$79.55	\$71.59



BLICK® floor easels



BEST seller!

G Blick® Studio Inclinable Lyre Easel

Beautifully crafted of smooth, sanded hardwood, this compact easel is ideal for small studios and work spaces. It tilts back to 60° for painting, slightly forward for pastel work. It holds canvas and panels up to 50"H, yet the base measures just 22"W x 39"D. The 22" wide carriage tray has an easy-adjust metal ratchet. Mast extends 64" to 88" high. Folds flat for storage. Weighs 11 lb.

NUMBER	EACH
A51753-1040	\$122.17

H Blick® Studio Convertible Easel

Tilt this versatile easel back, forward, or horizontally to accommodate a range of painting mediums. Quick-release hinges allow for easy conversion. Made of premium, hand-sanded beechwood, it's equipped with a handy lower shelf for tools and supplies. Holds canvas or panels up to 50" high. Adjustable carriage tray measures 22" wide. Base measures 21-1/2"W x 21-1/2"D. Folds flat for storage. Weighs 17 lb.

NUMBER	EACH
A51753-1010	\$169.64

I Blick® Studio Classic Field Easel

Slim, lightweight, and fully collapsible, this easel is great indoors and out. Weighing just 3 lb, it's easy to transport in the field — and just as easy to store in your home or studio. Set in upright position for oils and acrylics, forward for pastels, or horizontal for watercolor. Crafted of hand-sanded hardwood. Base measures 36"W x 44"D. Holds artwork up to 28" high.

NUMBER	EACH
A51753-1030	\$66.79

J Blick® Studio Traditional Lyre Easel by Jullian®

An easel with traditional A-frame styling and beechwood construction. The center mast can be tilted forward up to 15° for pastel work. This sturdy easel holds artwork up to 53" high. The ratchet height mechanism is quick and easy to adjust. The rear leg folds in for easy storage. Base measures 26"W x 30"D. Weighs 16 lb.

NUMBER	EACH
A51770-1001	\$220.50



A



C



B



D

A Blick® Studio Medium-Duty H-Frame Easel
Ideal for medium and large canvas or panels up to 86" high, this H-frame easel is stable, functional, and built to last. Finely handcrafted of smooth, sanded beechwood, with an adjustable-height mast that tilts back to any angle. Adjustable carriage tray measures 26"W x 4"D and has built-in storage. Base measures 26"W x 26"D. Folds for storage. Weighs 32 lb.

NUMBER	EACH
A51753-1050	\$207.69

B Blick® Studio Heavy-Duty H-Frame Easel
Designed for artists who work on a grand scale, this heavy-duty easel holds large canvas or panels up to 100" high with dual masts for extra stability. Casters let you wheel it anywhere. The base measures 30"W x 30"D and the adjustable carriage tray measures 27-1/2"W x 3"D. Folds for storage. Weighs 47 lb.

NUMBER	EACH
A51753-1060	\$303.00

C Blick® Studio Light-Duty H-Frame Easel
Stable, functional, and built to last, this light-duty easel is finely handcrafted of smooth, sanded beechwood and equipped with an adjustable-height mast that tilts back to any angle. Ideal for small to medium canvases or panels up to 48" high. Adjustable carriage tray measures 22"W x 1-1/2"D and has built-in storage. Base measures 24"W x 27"D. Folds for storage. Weighs 20 lb.

NUMBER	EACH
A51753-1020	\$137.91

D Utrecht® Single Mast Studio Easel
Sturdy and functional with a space-saving design. This easel holds artwork up to 50" high and folds flat for storage. Made of beechwood, its hinged rear leg adds extra stability. Its maximum height is 72". The base measures 31"W x 24-1/2"D. Ideal for oil, acrylic, and pastel painting. Weighs 11 lb.

NUMBER	EACH
A51763-1002	\$121.99



E Studio Designs™ Tubular Metal Black Easel
This large, sturdy easel features 1-1/2" tubular double-post construction. Holds canvas up to 75" high. Shure Clamp height/tilt adjustment. 21-1/2" x 5" storage shelf. 20" x 21" base. Assembly required.

NUMBER	EACH	3/EA
A51548-2050	\$143.96	\$129.60

F Torino™ Aluminum Easel
Lightweight and adjustable, this easel folds and carries easily with a handle and ergonomic knobs. It's 53" tall and holds artwork up to 46" high. It has a black aluminum finish and can be tilted over a 30° range. Adjust the upper and lower canvas supports to any height within the range of the central mast. The easel's base is 34"W x 30"D. Weighs 5 lb.

NUMBER	EACH	6/EA
A50261-1001	\$174.46	\$156.99

G Martin™ Universal Avanti® II Easel and Tray
Beauty and strength combine in the Avanti II studio easel. Holds canvases and drawing boards up to 72" high. Fully adjustable and inclinable, made of sturdy chromium-plated steel. Base is 22" x 20". Heavy-duty steel working tray attaches to Avanti II easels and rotates on center axis. 19-1/2"W x 26-1/2"H x 12"D. Easel weighs 25 lb. Assembly required. FOB Factory. See page 648 for details.

NUMBER	DESCRIPTION	EACH	3/EA
AF50260-2000	Black & Chrome	\$405.00	\$375.00
AF50260-2100	Tray (Black)	112.73	101.46

H Testrite® Classic Studio Aluminum Easel
Highly functional, lightweight, and very stable. The canvas tray is large enough to hold tools and tubes while the arms swing out to support a palette. Fully adjustable. 69" high. Folds flat for storage. Weighs 7.5 lb.

NUMBER	EACH	6/EA
A50207-0500	\$115.36	\$103.80

I Testrite® 12" Easel Extension
Add this aluminum extension to your Testrite Classic Easel to accommodate larger canvases. It extends the easel up to 12".

NUMBER	EACH	6/EA
A50207-1012	\$37.08	\$33.37

J Testrite® Superior Studio Aluminum Easel
Superior strength and durability in a lightweight aluminum easel. Holds jumbo canvases up to 86" high and features an inclinable center section that allows canvases to be tilted forward up to 30°. Adjustable, folding rear leg for easy movement and storage. 24" wide bottom shelf with palette holder; 25" across bottom legs. 60° closed; 90° open. Rubber tips on legs. Weighs 8.5 lb.

NUMBER	EACH	6/EA
A50235-0000	\$187.69	\$168.90



K Testrite® Professional Studio Aluminum Easel
Extra sturdy and rigid, yet lightweight and easy to pick up and move. Accommodates canvases up to 60" high. Hinged back, center section can be raised and lowered. Folds flat for space-saving storage. Utility tray with palette holder is 24"W x 25"D. Overall height 72". Aluminum. Weighs 15 lb.

NUMBER	EACH	3/EA
A50236-0000	\$230.63	\$207.60

Did you know we have hundreds of lesson plans designed to meet the National Standards for Visual Arts Education? See them all at DickBlick.com/lesson-plans.

KLOPFENSTEIN™



A Klopfenstein™ Spectrum Challenge Easel

Telescoping easel with an innovative design for maximum adjustability of canvas tray and tilt angle — great in the classroom or studio. Provides a secure hold on paintings up to 72" high. Easy-to-use, twist-locking mechanism. Heavy-gauge 1-1/4" and 1" steel tubing. Folds flat to 6-1/4"H for storage and transport. Base measures 20" x 25". Assembly required. Weighs 18 lb. FOB Factory. See page 648 for details.

NUMBER	EACH	5/EA
AF50350-0000	\$353.00	\$318.00

B Klopfenstein™ Collegiate Steel Art Easel

Made of strong, rigid steel tubing, this value-priced easel is a good choice for beginning artists. The mast extends to hold artwork up to 96" high and an upper clamp securely holds the canvas in place. The canvas tray quickly adjusts to any position and effortlessly locks into place. The easel folds to a compact 5" thick for easy storage. 58"H x 24"W x 29"D. Weighs 30 lb. FOB Factory. See page 648 for details.

NUMBER	EACH	3/EA
AF51551-0000	\$449.00	\$404.00

C Klopfenstein™ Steel Art Horse

As stable and compact as they come. The 18" x 24" top telescopes from 31" to 48" high and pivots a full 180° to accommodate any drawing position. It has dual-locking handles for no-slip performance. Seat and top are made of 3/4" solid MDF core with a smooth white melamine surface. Steel stops at the top and bottom edges secure papers, and drop below the table surface when not in use. Electrically welded for strength and stability. Base measures 24" x 30". Weighs 45 lb.

NUMBER	EACH	3/EA
A52998-0000	\$670.00	\$603.00

D Klopfenstein™ Spectrum Art Pony

An alternative to flimsy wood horses, the Art Pony has a heavy 1" square welded steel frame for long-lasting stability. Its solid 11-ply, 5/8" thick Baltic birch plywood seat is grooved in two places for positioning and anchoring a drawing board. The welded steel T-bar is 15" wide to support a 24"W x 30"H board and telescopes from 11" to 21" for flexibility. Steel lever securely locks the T-bar in place, and the adjustable leg levelers keep your pony reined in. Base measures 15" x 28". Weighs 20 lb. Fully assembled. FOB Factory. See page 648 for details.

NUMBER	EACH	5/EA
AF52823-1001	\$286.14	\$257.50

E Klopfenstein™ PE100 Steel Art Easel and Tray

Paintings up to 96" high are securely held in a backward or forward tilt utilizing sturdy steel adjustment levers. The upper clamp has a two-way adjustment to hold the canvas in any position (no twisting). A non-slip canvas tray automatically locks into place at any up or down position. And your floor is protected via its smooth plastic ball feet. Made of 1-1/4" steel tubing, electrically welded for permanent strength. Folds flat for storage. 58"H x 29"W x 33"D. Weighs 40 lb. FOB Factory. See page 648 for details.

NUMBER	EACH	3/EA
AF50316-1000	\$653.00	\$588.00

Easel Tray — Heavy-duty 14 gauge steel tray keeps your supplies easily accessible. It attaches instantly and securely to your Klopfenstein easel. No assembly required. 1-1/2"H x 20"L x 4"W. FOB Factory. See page 648 for details.

NUMBER	EACH	3/EA
AF50355-1001	\$83.90	\$75.52

F Klopfenstein™ SE100 Steel Art Easel

This H-frame easel is crafted of 3/4" steel tubing, electrically welded for lasting strength. The double mast extends to securely hold artwork up to 72" high, aided by an upper canvas clamp to prevent twisting. Large, round knobs make it easy to adjust the height and tilt angle. A non-slip canvas tray adjusts up or down and automatically locks into place. Smooth plastic ball feet won't mar your floors. Folds flat for storage. 58"H x 29"W x 33"D. Weighs 35 lb. FOB Factory. See page 648 for details.

NUMBER	EACH	3/EA
AF50317-1000	\$522.00	\$469.00

Easel Tray — Heavy-duty 14 gauge steel tray keeps your supplies easily accessible. It attaches instantly and securely to your Klopfenstein easel. No assembly required. 1-1/2"H x 20"L x 4"W. FOB Factory. See page 648 for details.

NUMBER	EACH	3/EA
AF50355-1001	\$83.90	\$75.52



G National Public Seating™ Adjustable Stool

Constructed of 7/8", 18 gauge steel tubing in three adjustable height sizes, this stool is built for years of service. The round seat is 14" in diameter with an 11-1/2" square masonite board recessed into the seatpan; will not chip or crack. 5/8" foot rings are welded to each leg, with four contact points at each leg for added stability. Chrome-plated inserts and tilt swivel glides. Height-adjustable legs install easily with screwdriver. FOB Factory. See page 648 for details.

Stool with Backrest — Curved steel back brace adjusts up/down and forward/back.

NUMBER	COLOR	HEIGHT	EACH
AF50086-2019	Black	19"-27"	\$77.67
AF50086-2025	Black	25"-33"	81.38
AF50086-2521	Gray	19"-27"	76.15
AF50086-2522	Gray	25"-33"	76.82
AF50086-2523	Gray	31"-39"	87.63

Stool without Backrest FOB Factory. See page 648 for details.

NUMBER	COLOR	HEIGHT	EACH
AF50087-2051	Black	19"-27"	\$57.86
AF50087-2052	Black	25"-33"	62.07
AF50087-2521	Gray	19"-27"	57.37
AF50087-2522	Gray	25"-33"	61.53
AF50087-2523	Gray	31"-39"	65.72

H National Public Seating™ Fixed-Height Stool

Quality, durability, and style are the standards for this superior stool. Its seam-welded 18 gauge steel frame and gray enamel finish with polyethylene feet stand up to heavy use. The 14" diameter seat is fastened to the frame with eight rivets — double the number found in most stools — which helps prevent warping. It also includes a footrest that's welded to each leg giving the stool the added strength to withstand daily use. FOB Factory. See page 648 for details.

NUMBER	COLOR	HEIGHT	EACH
AF50068-2118	Black	18"	\$42.07
AF50068-2124	Black	24"	43.79
AF50068-1018	Gray	18"	41.71
AF50068-1024	Gray	24"	43.79
AF50068-1030	Gray	30"	50.05

I National Public Seating™ Heavy-Duty Padded Stool

Designed to withstand years of heavy classroom or studio use, this stool is constructed of 18-gauge steel tubing. Sit comfortably for hours on the full 14" diameter seat with 11-1/2"Dia x 1/2" thick vinyl pad riveted through the steel seat pan. Foot rings are welded to each leg, with four contact points at each leg for added stability. Polyethylene feet. FOB Factory. See page 648 for details.

Stool without Backrest

NUMBER	COLOR	HEIGHT	EACH
AF50084-2022	Black	18"	\$50.49
AF50084-2521	Gray	18"	50.05
AF50084-2522	Gray	24"	53.19

Stool with Backrest — FOB Factory. See page 648 for details.

NUMBER	COLOR	HEIGHT	EACH
AF50084-2023	Black	18"	\$76.82
AF50084-2518	Gray	18"	76.15
AF50084-2524	Gray	24"	80.33

J National Public Seating™ Designer Swivel Stool

This durable stool is made from 18 gauge heavy-duty steel with a metal or wood seat, curved legs, and a footrest. The seat can swivel 360°. Adjust its height from 17-3/4" to 24-1/4" by turning the seat.

NUMBER	FRAME COLOR	SEAT COLOR	EACH
A52530-1202	Black	Black	\$130.32
A52530-1102	Black	Blueberry	130.32
A52530-1302	Black	Burgundy	130.32
A52530-1402	Black	Prussian Blue	130.32
A52530-1002	Black	Wood	130.32
A52530-1201	Gray	Black	130.32
A52530-1101	Gray	Blueberry	130.32
A52530-1301	Gray	Burgundy	130.32
A52530-1401	Gray	Prussian Blue	130.32
A52530-1001	Gray	Wood	130.32

Got a question about a product? Our experts have the answer!
Three ways to connect — Live Chat at DickBlick.com, call 800.933.2542, or email info@DickBlick.com.

K Wisconsin Bench Solid Hardwood Welded Stools

Built to withstand rigorous classroom and workshop use for many years to come. These stools feature an ultra-stable, fully welded, 16 gauge steel frame, a solid steel footring, and non-marring glides to protect floor surfaces. The durable black powder-coated finish is textured to help keep fingerprints from showing. Solid hardwood seat. FOB Factory. See page 648 for details.

NUMBER	STYLE	HEIGHT	EACH
AF52508-1008	4 Legs, Adjustable Height	18"-28"	\$206.32
AF52508-1007	4 Legs, Fixed Height	24"	155.32
AF52508-1003	5 Legs, Adjustable Height	18"-28"	218.11
AF52508-1006	5 Legs, Adjustable Height	22"-32"	219.49

L National Public Seating™ Elephant Z-Stool

This updated version of the popular Elephant Z-Stool is solid, durable, and comfortable. Plus, it's eco-friendly — fabricated from steel and plastic containing 30-40% recycled materials. The ergonomic, black molded seat is super comfortable, and the optional contoured backrest has fanback cutouts that allow air to circulate. The unique U-shaped chrome-plated base provides lots of stability. Offered in two styles (with or without backrest) and three heights. Bases measure 16-3/4"W x 16-1/2"D. FOB Factory. See page 648 for details.

Stool without Backrest

NUMBER	HEIGHT	EACH
AF51821-1018	18"	\$137.60
AF51821-1022	22"	141.91
AF51821-1024	24"	150.51

Stool with Backrest — FOB Factory. See page 648 for details.

NUMBER	HEIGHT	EACH
AF51821-2018	18"	\$185.99
AF51821-2022	22"	192.46
AF51821-2024	24"	198.91

M Richeson™ Lyptus™ and Steel Stools

These elegant and functional stools look great anywhere. The smooth, comfortable 13-1/2" diameter seats are made of Lyptus wood, a sustainable, premium-grade hardwood grown on eco-friendly plantations in South America. A steel cross-brace under the seat adds extra strength, and the sturdy black steel legs hold up to long-term use. Base has an 11-1/2" diameter footprint.

NUMBER	HEIGHT	EACH
A52588-1018	18"	\$105.50
A52588-1024	24"	107.99
A52588-1030	30"	131.51





A Bieffe Drafting Chair and Stool

A stylish and functional seat made in Italy from sturdy beechwood. Both stool and chair feature a chrome-plated, five-star steel pedestal base with non-marring floor glides, an adjustable foot ring, and pneumatic height adjustment from 21" to 31".

NUMBER	DESCRIPTION	COLOR	EACH	6/EA
A50076-1010	Drafting Stool	Birch/Chrome	\$223.50	\$201.15
A50076-2020	Drafting Stool	Black	253.90	228.50
A50076-1020	Drafting Chair	Birch/Chrome	273.65	246.29
A50076-2021	Drafting Chair	Black	278.90	250.99

B Alvin® LabTek Utility Chair

This rugged drafting-height chair adjusts as needed for maximum comfort. Features include pneumatic height control (23" to 33"), a height- and depth-adjustable hinged backrest, and a 25" diameter reinforced nylon base with foot ring. Its polyurethane seat and backrest stand up to heavy use, resisting punctures, water, and most chemicals. Includes a set of non-locking casters and a set of floor glides. FOB Factory. See page 648 for details.

NUMBER	EACH	6/EA
AF51824-1001	\$260.68	\$234.60

C Alvin® American-Style Draftsman's Chair

A ruggedly constructed traditional chair that offers both comfort and durability. Features include pneumatic height control, a height- and depth-adjustable hinged backrest with polypropylene back shell, dual-wheel casters, a 23" tubular chrome steel base with built-in foot ring, and a molded foam seat. Height adjusts from 23" to 31". Includes a set of locking casters and non-slip foot glides. FOB Factory. See page 648 for details.

NUMBER	EACH	12/EA
AF51810-2610	\$184.71	\$166.30

D National Public Seating® Polyshell Stacking Chairs

Sturdy and lightweight, these chairs are easy to maneuver for temporary setups yet can also handle the rigors of long-term institutional use. The anti-static, one-piece seat is made from injection-molded, high-density polypropylene. The 17 gauge, 7/8" square tubular chrome frame has three under-seat cross braces for extra stability and bumpers that protect the finish when stacked (may safely be stacked 12 high). Each measures 31"H x 19-1/4"W x 19-1/4"D. FOB Factory. See page 648 for details.

NUMBER	COLOR	EACH	4/EA
AF52564-2023	Black	\$57.22	\$51.49
AF52564-5013	Blue	57.22	51.49
AF52564-3143	Burgundy	50.07	45.07



National Public Seating® Folding Tables

Lightweight, sturdy, and affordable — great for schools and institutions. Tops are made of eco-friendly, blow-molded plastic, so they're highly durable and safe for indoor or outdoor use. In fact, they stand up to temperatures as high as 212°F! Frames are made of 17-19 gauge steel with wishbone legs for extra stability. Speckled Gray finish. FOB Factory. See page 648 for details.

NUMBER	SIZE	EACH
AF52859-1360	30" x 60"	\$103.19
AF52859-1372	30" x 72"	121.47
AF52859-1396	30" x 96"	169.87

FOB Factory. See page 648 for details.

NUMBER	SIZE	EACH
AF52859-1048	48" Round	\$133.30
AF52859-1060	60" Round	211.59
AF52859-1071	71" Round	288.18



National Public Seating® High Durability Folding Table

Lightweight and weather-resistant, this table has a speckled gray, powder-coated, 19 gauge steel frame and a high-density polyethylene top. Its safety gravity rings prevent table legs from collapsing while in use. It's also equipped with locking technology that automatically secures the tabletop in place. Fold it in half for easy transport and storage.

NUMBER	EACH
A50588-2500	\$135.87



Correll® Adjustable Height Folding Tables

Expect years of lasting value from this folding table. Its heavy-gauge, tubular steel pedestal legs adjust from 22" to 32" high in 1" increments. Gravity-activated locking rings securely lock legs into place. Tabletop is made of high-pressure laminate with a solid core. Walnut finish. Truck Shipment and FOB Factory. See page 648 for details.

NUMBER	SIZE	EACH
AF50136-1207	30" x 60"	\$220.49
AF50136-1507	30" x 72"	231.51
AF50136-1807	30" x 96"	260.91
AF50136-1210	36" x 72"	265.51
AF50136-1510	36" x 96"	290.31



E Studio Designs™ Fusion Center

Plenty of workspace and storage galore with a lower shelf, mesh drawers, and a 24" metal art tray with a flexible foam organizer for pencils, markers, and brushes. The tabletop is height adjustable and tilts up to 60°. The set also includes a padded stool (21" high). Measures 35-1/2"H x 49"W x 25-1/2"D overall. For more details, visit DickBlick.com.

NUMBER	EACH
A52591-1001	\$248.03

F Studio Designs™ Folding Craft Station

This portable alternative is easy to set up and put away. It includes four floor levelers, a slide-up pencil ledge, and four removable side trays. The tabletop adjusts from 0–35°. It measures 30"H x 42"W x 25"D with trays. FOB Factory. See page 648 for details.

NUMBER	DESCRIPTION	EACH
A51917-2050	Black Base, White Top	\$177.15
AF51917-2410	Silver Base, Tempered Safety Glass Top	221.82

G Studio Designs™ Triflex Sit-to-Stand Drawing Table

Easily shift from a writing table to a drafting or standing desk. The base of this table adjusts to sitting or standing height and the top tilts for a variety of projects. It has a durable, powder-coated steel with a blue glass top and includes four storage trays, a slide-up pencil ledge, and floor levelers. Measures 40-3/4"W x 29"D overall. For more info, visit DickBlick.com

NUMBER	COLOR	EACH
A52578-2120	Charcoal Frame/Clear Glass	\$279.56
A52578-2130	Charcoal Frame/White Top	203.38
A52578-9330	Silver Frame/Blue Glass	279.56

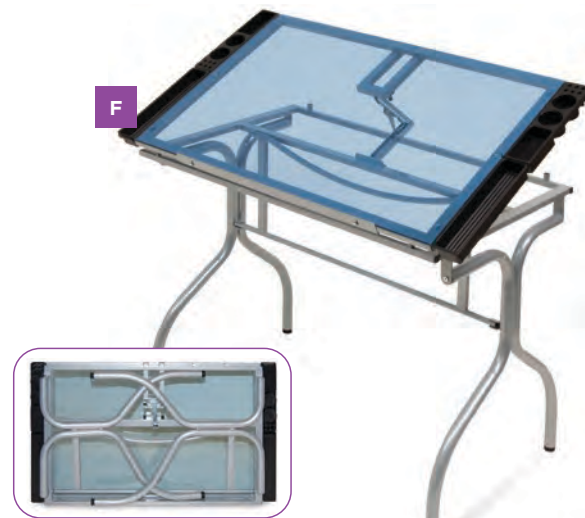

H Blick® Studio Ion Table by Studio Designs™

Simple yet sturdy, this table is designed for years of use. It features an attractive wood-grain laminate top and a durable, powder-coated steel frame. Tilt the work surface up to 35°. The table's dual tilt mechanisms offer greater support. A pullout drawer provides storage. Measures 31-1/2"H x 42"W x 23-1/2"D overall.

NUMBER	EACH
A52593-1001	\$206.69



I Blick® Studio Polaris Table by Studio Designs™

Perfect for sketching and tracing, this table has a tempered glass top and durable, powder-coated steel frame. A metal pullout drawer and slide-up pencil ledge keep supplies close at hand. Tabletop adjusts up to 40°. 32-3/4"H x 40-1/2"W x 23-1/2"D overall.

NUMBER	EACH
A52592-2020	\$212.89



A Alvin Vycro Drawing Board Covers

A durable five-ply vinyl board cover manufactured especially for the protection of heavily used surfaces. Self-healing surface recovers almost immediately while protecting expensive furniture from wear and tear. Secure with double-sided tape.

NUMBER	COLOR	SIZE	EACH	12/EA
A22830-7009	Green/Cream	18" x 24"	\$36.44	\$32.80
A22830-7015	Green/Cream	24" x 36"	55.59	49.99
A22830-7005	Green/Cream	31" x 42"	64.65	58.17
A22830-7027	Green/Cream	36" x 48"	81.23	73.10
A22830-7008	Green/Cream	37-1/2" x 60"	90.64	81.58
A22830-7007	Green/Cream	37-1/2" x 72"	98.04	88.23
A22830-2509	Gray/White	18" x 24"	36.44	32.80
A22830-2515	Gray/White	24" x 36"	55.59	49.99
A22830-2505	Gray/White	31" x 42"	64.65	58.17
A22830-2527	Gray/White	36" x 48"	81.23	73.10
A22830-2508	Gray/White	37-1/2" x 60"	90.64	81.58
A22830-2507	Gray/White	37-1/2" x 72"	98.04	88.23
A22830-1015	Translucent	24" x 36"	55.59	49.99
A22830-1005	Translucent	31" x 42"	64.65	58.17
A22830-1027	Translucent	36" x 48"	81.23	73.10
A22830-1060	Translucent	37-1/2" x 60"	90.64	81.58

B Klopfenstein Tilt-Top Art Table

A favorite among teachers and schools, this versatile table features a welded, heavy-duty metal base that measures 28"W x 17"D. The spring-assisted top is sturdy 3/4" solid core melamine with a smooth surface and rounded corners. The top telescopes from 32" to 45" high and pivots 180°. Dual-pivot bracket clamping knobs provide slip-proof positioning at any angle. Multiple tables nest together for compact storage. Assembly is required. Truck Shipment and FOB Factory. See page 648 for details.

NUMBER	SIZE	EACH
AF51621-1016	36"W x 30"D	\$547.00
AF51621-1006	42"W x 30"D	666.00



C Debcor Adjustable Art & Activity Table

Large work area, multi-purpose, heavy-duty table accommodates a broad range of needs — ideal for grouping a small art class. The edged top is 60" x 42" x 1-1/4" thick, and its durable laminate surface resists stains and scratches. Easy-to-assemble, sturdy steel base with floor glides. Offered with a fixed height of 29-1/2" or with an adjustable height range of 26-1/2" to 30-1/2". Durable powder-coated finish, putty color. Truck Shipment and FOB Factory. See page 648 for details.

With Square 3 mm PVC Edged Top — Top is squared with laminate surfaces. 155 lb.

NUMBER	DESCRIPTION	EACH
AF50100-1060	Adjustable Height	\$797.00
AF50100-8480	Non-Adjustable Height	576.00

With Rounded Armor Edge Top — Top is laminate over MDF core with rounded, tough coated edge. 164 lb. Truck Shipment and FOB Factory. See page 648 for details.

NUMBER	DESCRIPTION	EACH
AF50100-1160	Adjustable Height	\$1037.00
AF50100-8490	Non-Adjustable Height	693.00

D Bieffe AF15 Drafting Table

Both the height and tilt of this versatile table are easily adjustable to suit any project such as drawing, designing, or computer work. Superb, clean styling and solid fabrication make it an excellent choice for the home or studio. It's constructed of heavy-gauge steel with a chip-resistant, premium baked enamel finish. Rubberized feet add stability to the base and help protect floor surfaces from scratches and scuff marks. The tabletop can be adjusted to any height between 29–40" and the base measures 34-1/2"W x 26"D.

NUMBER	DESCRIPTION	SIZE	EACH
A51939-1030		42"L x 30"W	\$207.89
A51939-1036		48"L x 36"W	208.99
A51939-1001	Tablet Side Tray	23-1/2"L x 7"W x 2-1/2"D	29.77

E Diversified Woodcrafts Drawing Table

Featuring solid, durable construction and a choice of 10 different feature combinations for versatility. Choose from three frame heights with solid 2 1/2" maple legs and aprons. Next, select your style of top: the classic one-piece or multifunctional two-piece. The one-piece top adjusts from 0 to 30 degrees and includes a soft close feature and pencil stop. The two-piece top has a larger, adjustable side and a smaller, flat, fixed side for holding supplies. For even more storage, add a drawer. Measuring 2"H x 20 1/2"W x 18"D, it has plenty of room to hold writing instruments, papers, and more. Made in the USA. Backed by a limited lifetime warranty. For full details, visit DickBlick.com.

1 Piece Top

NUMBER	DESCRIPTION	SIZE	EACH
A51938-2001	Without Drawer	24" W x 36" L x 30" H	\$620.00
A51938-3001	Without Drawer	24" W x 36" L x 36" H	698.00
A51938-1001	Without Drawer	30" W x 42" L x 39.75" H	609.00
A51938-4001	With Drawer	24" W x 36" L x 30" H	881.00
A51938-5001	With Drawer	24" W x 36" L x 36" H	715.00
A51938-3002	Without Drawer	24" W x 36" L x 36" H	727.00
A51938-2002	Without Drawer	24" W x 36" L x 30" H	657.00
A51938-1002	Without Drawer	30" W x 42" L x 39.75" H	630.00
A51938-4002	With Drawer	24" W x 36" L x 30" H	894.00
A51938-5002	With Drawer	24" W x 36" L x 36" H	725.00



F Fox Haase Four-Post Tilt-Top Table

A four-post design and 2" thick solid wood legs make this an exceptionally sturdy table for the classroom, studio, or office. Tabletop tilts to a 90° angle and features multi-ply veneers with a finely sanded birch face. FOB Factory. See page 648 for details.

NUMBER	SIZE	EACH
AF51903-3042	30" x 42"	\$364.00
AF51903-3648	36" x 48"	391.00



G-H Hann Drawing Tables

These versatile, space-saving tables are built to take classroom use and abuse. They feature natural almond Fiberesin drawing surfaces with ratchet tilting mechanisms that permit flat or inclined positioning. Hard maple rails are joined to the 2-1/4" square legs with mortise and tenon joints and strong steel corner brackets. For more product info, visit DickBlick.com. Truck Shipment and FOB Factory. See page 648 for details.

NUMBER	DESCRIPTION	EACH
AF51698-1030	G 2-Station	\$1430.00
AF50185-1001	H 4-Station	1425.00



I Diversified Woodcrafts Art and Drafting Light Table

A desk and light box in one! With a maple hard wood frame and a plastic laminate almond colored top, this table has a shatter-resistant glass inset for light to shine through. The light box offers maximum diffusion of light with minimum glare and no hot spots. It features a 120V electrical cord and four energy efficient fluorescent tubes. The top of the desk adjusts from 0° to 30° and has a pencil ledge, plus a soft-close feature with a pencil stop. It measures 39-3/4"H x 44"W x 24"D.

NUMBER	EACH
A80049-1001	\$1410.00

J Diversified Woodcrafts Instructor Drafting Tables

This table has two locking storage drawers — one for prints and the other for drawing supplies. The top of the table is adjustable from 0° to 30°, and it includes a pencil stop and soft-close hinges. Made of solid maple with a 3/4" plastic laminate top.

NUMBER	SIZE	EACH
A80478-1001	36" x 60" x 37-1/2"	\$1506.00
A80478-1002	36" x 72" x 37-1/2"	1525.00

K Diversified Woodcrafts Planning and Layout Bench

Store layouts, paper, supplies, and more. Four paper storage drawers, one file drawer, and four smaller drawers each have dovetailed construction and a lock. The bench is made of maple-veneered plywood with a solid maple apron and legs and a fully finished back. It measures 37"H x 72"W x 30"D overall.

NUMBER	EACH
A80477-1001	\$2205.00



Diversified Woodcrafts™ Plain Apron Tables

Apron and legs are crafted of solid red oak joined with heavy-duty steel hardware. The wood is smoothly machined and preserved with a chemical-resistant, UV-resistant, Earth-friendly finish. Rubber leg boots protect the finish from floor cleaning products. Choose from three tabletop surfaces. FOB Factory. See page 648 for details.

ChemGuard Top — A treated laminate with outstanding chemical resistance.

NUMBER	SIZE	EACH
AF52568-2000	24" x 48"	\$395.00
AF52568-2003	24" x 54"	426.00
AF52568-2005	24" x 60"	417.00
AF52568-2004	24" x 72"	499.00
AF52568-2001	30" x 60"	494.00
AF52568-2002	30" x 72"	568.00

Epoxy Resin Top — Solid black epoxy resin is extremely durable and completely impervious to chemicals, heat, and moisture. Truck Shipment and FOB Factory. See page 648 for details.

NUMBER	SIZE	EACH
AF52568-2051	24" x 54"	\$627.00
AF52568-2053	24" x 60"	704.00
AF52568-2052	24" x 72"	808.00
AF52568-2050	30" x 60"	834.00

Plastic Laminate Top — High-pressure black laminate. FOB Factory. See page 648 for details.

NUMBER	SIZE	EACH
AF52568-2020	24" x 48"	\$365.00
AF52568-2022	24" x 52"	383.00
AF52568-2024	24" x 60"	371.00
AF52568-2023	24" x 72"	430.00
AF52568-2021	30" x 60"	430.00



Hann™ Art Workbench

Designed to accommodate multiple students, this rugged, solid maple workbench features durable, time-tested construction methods including mortise and tenon joinery and heavy-duty, Thru-Bolt connections. The substantial, 2-1/4" thick butcher-block top can be renewed as necessary. The lower shelf is comprised of solid maple slats — strong enough for any storage requirement and prevents debris buildup.

NUMBER	DESCRIPTION	SIZE	EACH
A51931-1002	Dual-Station	32"H x 64"W x 28"D	\$919.00
A51931-1004	Four-Station	32"H x 64"W x 54"D	1565.00



Double draw bolt lower spreader provides excellent rigidity and resists loosening.

Upper spreader provides necessary support along the length of the top.

Leg panels are mortise and tenoned to the foot and crossbar, glued and reinforced w/ two large lag bolts for a lifetime connection.

Appropriately sized components and hardware for stability and durability: 1-1/2" thick feet and crossbars, 1-1/4" thick leg panels and spreaders.

With Shelf

Hann™ Art Tables

These multi-purpose art tables makes sturdy and attractive platforms for student projects. Solid maple base is mortise and tenon jointed for strength and durability. Heavy base components and wide feet fitted with adjustable floor glides contribute to excellent stability. A double-bolt lower leg spreader and an upper leg spreader prevent wobbling. Assembly required. Truck Shipment and FOB Factory. See page 648 for details.

Laminate Top — 1-1/4" thick heavy-duty top is maple grain laminated plastic over particleboard with nick-resistant 3 mm PVC edge banding.

NUMBER	DESCRIPTION	SIZE	EACH
AF51631-1020	With Shelf	60" x 30" x 42"	\$762.00
AF51631-1010	Without Shelf	60" x 30" x 42"	538.00

Maple Top — 1-3/4" thick solid hard maple. Truck Shipment and FOB Factory. See page 648 for details.

NUMBER	DESCRIPTION	SIZE	EACH
AF51631-8403	Without Shelf	60" x 30" x 26"	\$705.00
AF51631-8410	With Shelf	60" x 40" x 30"	1117.00
AF51631-8400	Without Shelf	60" x 40" x 30"	845.00



Colored Top— Truck Shipment and FOB Factory. See page 648 for details.

NUMBER	COLOR	EACH
AF51631-2050	Black	\$568.00
AF51631-5910	Blue	568.00
AF51631-3300	Red	568.00



Diversified Woodcrafts™ Shop-Bilt Adaptable Table

This table is perfect for the classroom since its height adapts easily to accommodate any student. It has a super heavy-duty top and frame that withstand heavy use, yet the height can be adjusted with just two fingers. Adjustable in 1" increments from 26" to 38" high. It also can sit on an inclined surface. Powder-coated silver legs have adjustable glides. FOB Factory. See page 648 for details.

NUMBER	DESCRIPTION	EACH
AF51617-2053	Black 30" x 60" Laminate Top	\$870.00
AF51617-2054	Black 42" x 60" Laminate Top	945.00



4 Door Workbench with Visés

12 Vertical Lockers with Visés

Hann™ Four-Station Locker-Type Workbench

There's plenty of room for storage in this 12-locker workbench with its two gray steel base units placed back to back, each measuring 31"H x 36"W x 21"D, with lockers measuring 10"H x 18"W x 21"D. It features a specially constructed maple top which is 64"L x 54"W x 2-1/2"D. The sturdy locker doors are equipped with spring hinges and padlock hasps. It is available with or without vises. Truck Shipment and FOB Factory. See page 648 for details.

NUMBER	DESCRIPTION	WEIGHT	EACH
AF50115-2600	12 Vertical Lockers	412 lb	\$2818.00
AF50115-2701	12 Horizontal Lockers	400 lb	2618.00
AF50115-9010	4 Door Workbench	412 lb	2245.00

Bench with 4 Woodworking Visés — Truck Shipment and FOB Factory. See page 648 for details.

NUMBER	DESCRIPTION	WEIGHT	EACH
AF50115-2500	12 Vertical Lockers	532 lb	\$3582.00
AF50115-2702	12 Horizontal Lockers	563 lb	3678.00
AF50115-9004	4 Door Workbench	504 lb	3276.00



Hann™ Steel Workbench with Maple Top

Give it your best shot! We bet you can't destroy this table! 32" high welded heavy-gauge steel legs with a durable gray finish are connected by steel stringers that add rigidity and eliminate sway. The laminated 1-3/4" thick hardwood top is made of the finest kiln-dried, air-seasoned maple, and its smooth natural finish is achieved through multiple coats of hot lacquer. The top surface spans across the legs and overhangs by 1-1/2" on each side. Features all-steel utility shelf and drilled holes for floor mounting. Shipped unassembled. Truck Shipment and FOB Factory. See page 648 for details.

NUMBER	SIZE	WEIGHT	EACH
AF50126-1024	24" x 60"	118 lb	\$740.00
AF50126-1124	24" x 72"	136 lb	803.00
AF50126-1008	30" x 60"	132 lb	795.00
AF50126-1108	30" x 72"	161 lb	903.00



Hann™ Four-Student "X" Table

Sturdy mortise-and-tenon construction combined with intersecting "X" bracing means this table is ready for serious work. Plus, it offers plenty of legroom on all four sides. The solid maple top is 1-1/4" thick. Overall: 30"H x 48"W x 48"D. Includes adjustable leg glides. Truck Shipment and FOB Factory. See page 648 for details.

NUMBER	EACH
AF51915-8410	\$1052.00



Diversified Woodcrafts™ Fab-Lab Workbenches

Perfect for makerspaces and fab-labs. Height adjustable from 25-1/2" to 35-1/2", it includes casters for an extra 4" in height. Versatile and durable, its legs and frame are made from 18 gauge steel with a gray, baked enamel finish. It has a 1500 lb weight capacity without casters, and a 1200 lb weight capacity with casters. It also comes with an optional 18 gauge, 8"D storage shelf.

NUMBER	SIZE	EACH
A80475-1002	60" x 30"	\$1116.00
A80475-1006	72" x 30"	1162.00
A80475-1010	96" x 30"	1371.00

NUMBER	SIZE	EACH
A80475-1003	60" x 30"	\$1116.00
A80475-1007	72" x 30"	1162.00
A80475-1011	96" x 30"	1371.00

NUMBER	SIZE	EACH
A80475-1001	60" x 30"	\$1246.00
A80475-1005	72" x 30"	1329.00
A80475-1009	96" x 30"	1523.00

NUMBER	SIZE	EACH
A80475-1004	60" x 30"	\$1306.00
A80475-1008	72" x 30"	1603.00
A80475-1012	96" x 30"	2035.00

NUMBER	DESCRIPTION	SIZE	EACH
A80475-1013	Shelf	For 60" x 30" Table	\$249.23
A80475-1014	Shelf	For 72" x 30" Tables	258.08
A80475-1015	Shelf	For 96" x 30" Tables	289.79
A80475-1016	Casters		244.07



Blick® Studio Taboret

Keep supplies close at hand inside three open shelves. This taboret is made from beechwood and plywood with wheels for easy mobility. It includes a cup for holding water, drawing materials, brushes, and more, and the top shelf has ridges for placing supplies that could roll away. It measures 34-3/4"H x 27-1/2"W x 15-3/4"D overall.

NUMBER	EACH
A52065-1001	\$183.19



Blick® Artists' Taboret by Jullian®

Offers great storage space to keep every artist organized, plus an additional foldaway side shelf. Includes three storage drawers, two removable/adjustable shelves, a removable Plexiglas® palette, and two stainless steel canisters for brushes and other tools. Crafted of European beechwood. Casters for mobility. 35-1/2"H x 17-1/2"W x 14-1/2"D.

NUMBER	EACH
A52116-1001	\$397.00



The Art Horse

This highly functional and sturdy piece of art furniture is designed for comfort. The upright and grooved seat accommodates boards up to 24" x 30". Grooves are 3/4"W x 1/4"D, designed to hold drawing boards in place. The seat is 17"H x 12"W x 29"D and the drawing board rest is 33"H x 12"W. Durable, particle-board construction. Bottom brace for greater stability.

NUMBER	EACH	6/EA
A52916-1003	\$140.47	\$126.43



Richeson® Caballito Art Horse

Designed for student comfort as well as easy storage in the classroom, this bench is made of hardwood and plywood to provide a great workspace at a low price. Sturdy and stable, it's also simple to disassemble and stack. Accommodates boards up to 24" x 30". Base is 29"W x 13-1/2"D. Bench height is 17-1/4". Golden Oak color. FOB Factory. See page 648 for details.

NUMBER	EACH	6/EA
AF51547-0000	\$162.36	\$146.11



Luxor® Heavy-Duty Utility Carts

These heavy-duty utility carts are ready to roll with an integrated push handle molded into the top shelf. Easy-moving, quiet, 4" casters (two locking) let you wheel tools and supplies anywhere you need them. Will not stain, scratch, dent, or peel. Easy assembly. Lifetime warranty. FOB Factory. See page 648 for details.

NUMBER	DESCRIPTION	SIZE	EACH
AF52014-2052	Two-Shelf Cart	36"H x 24"W x 18"D	\$134.81
AF52014-2083	Three-Shelf Cart with Flat Top	40-1/2"H x 24"W x 18"D	173.82
AF52014-2053	Three-Shelf Cart	40-1/2"H x 24"W x 18"D	169.26



Diversified Woodcrafts™ Art Bench

Sturdy and solid. A built-in shelf provides a handy place to store books and supplies. Made of 3/4" solid maple and finished with an earth-friendly, chemical-resistant UV finish, it has a 300 lb weight capacity. 17"W x 12"D. FOB Factory. See page 648 for details.

NUMBER	SIZE	EACH
AF52594-1017	17"	\$222.20
AF52594-1026	26"	493.00



National Public Seating® CoGo Chair

Ergonomically designed for all-day support, this versatile chair has a 16 gauge steel pyramid frame and a fiberglass-reinforced polypropylene seats with a waterfall edge. It swivels and rolls on twin-wheeled 2" casters. It includes a 16-3/4"W x 16-3/4"D storage space and a smooth, poly-reinforced 19-1/2"W x 13-3/4"D tablet arm. 440 lb weight capacity.

NUMBER	COLOR	EACH
A80495-2020	Black	\$435.00
A80495-5010	Blue	435.00
A80495-3010	Red	435.00



Studio Designs Ashwood Homeroom Desk and Bench

Featuring a simple, compact design with ample room for projects. The desk and bench have a powder-coated matte graphite finish with an Ashwood desk top and bench seat with 1" thick top surfaces. Corners are rounded for safety. Includes a pencil drawer. Desk measures 30 3/4"H x 43 3/4"W x 19 3/4"D. Bench measures 17"H x 23 1/2"W x 9 1/2"D.

NUMBER	EACH
A51841-1001	\$115.98



Smith System Flavors Chairs

Shaped by the demands of the active classroom, these versatile chairs offer comfort to students facing back or front, left or right. With just the right amount of flex for adjusting posture. 18". For more sizes, visit DickBlick.com.

NUMBER	COLOR	EACH
A51820-7118	Apple	\$109.52
A51820-2018	Black	109.52
A51820-5918	Blueberry	109.52
A51820-3218	Burgundy	109.52
A51820-5018	Navy	109.52
A51820-5218	Persian Blue	109.52



Victor® High Rise™ Mobile Desk

The ergonomic benefits of an adjustable desk with the versatility of a mobile cart. This desk rises as high as 44" and lowers to 29", the standard sitting desk height. 31"W x 22"D.

NUMBER	EACH
A52502-2020	\$246.81



Safco Elevate Standing Height Desk

NUMBER	COLOR	EACH
A80576-8450	Natural	\$244.05
A80576-8910	Walnut	248.64



Safco AlphaBetter Stand-Up Desks and Stool

Get students up and engaged with this adjustable-height desk! Provides options to sit or stand with a noise-free swinging footrest to redirect fidgeting behavior. Perfect for students in grades 3–12, this flexible desk adjusts in 1-1/4" increments from 26" to 42". Desk features a durable 28" x 20" work surface. The Premium Top desk features 3/8" thick phenolic (a hard, dense industrial laminated plastic) for superior durability and a slimmer profile. The Standard Top is made with 5/8" thick MDF and rigid thermoplastic laminate. Both surfaces are fire, chemical, and impact resistant. A built-in pencil groove keeps writing tools in reach, while a lower bookshelf keeps supplies and personal items neatly tucked away. Stool seat measures 13"W x 13"D and is made of 5/8" MDF with laminate. Stool height adjusts in 1-1/4" increments (21-1/2" to 35-1/2") to accommodate students of various ages and sizes. For more details, visit DickBlick.com.

NUMBER	DESCRIPTION	COLOR	EACH
A52583-1028	Standard Top Desk	Beige/Black	\$472.00
A52583-1128	Standard Top Desk with Book Box	Beige/Black	596.00
A52583-1228	Premium Top Desk with Book Box	Gray/Black	628.00
A52582-2021	Up Stool	Black	227.31

Oklahoma Sound® EduTouch Sit-Stand Carts

Experience the option to sit or stand while you work. These carts can accommodate all your work necessities, including a laptop, and they have a keyboard tray. They have strong, powder-coated steel frames and hooded double-wheel casters for easy mobility. They're height-adjustable from 27-3/4" to 44-1/2".

NUMBER	EACH
A52333-1001	\$260.32

EduTouch Pro — All the features of the EduTouch Sit-Stand Cart, plus the option to use a desktop or laptop computer. Attach your computer screen to the cart's monitor arm and place your CPU on the adjustable mount at the base of the cart. It has a side shelf that pulls out, providing extra surface space. It also has an attached ABS plastic basket for paper storage.

NUMBER	EACH
A52333-1002	\$540.00



A

A ErgoErgo™ Stools

Perfect for active sitting, these stools encourage movement and activate your core for better concentration and improved posture. They compress slightly to the height of a standard chair when you sit on them. Adjust them by tilting the stool or scooting backwards or forwards

ErgoErgo KidsErgo Stool

NUMBER	COLOR	EACH
A51996-5011	Blue	\$100.79
A51996-7011	Green	100.79
A51996-4511	Orange	100.79
A51996-3060	Pink	100.79
A51996-6001	Purple	100.79
A51996-4011	Yellow	100.79

Standard — This size is suitable for people from 5 feet to 6 feet 4" tall.

NUMBER	COLOR	EACH
A51996-7170	Apple Green	\$138.59
A51996-2020	Black	138.59
A51996-5010	Blue	138.59
A51996-6170	Plum	138.59

B Kore™ Kids Wobble Stool

This ergonomically designed stool has a rounded, yet stable base that moves along with the child and rests naturally upright. Perfect for high-energy children and children with ADD, ADHD, and autism, the stool has been proven to help kids focus. A patented anti-roll safety ring on the base inhibits tipping. The stool is made with durable, recyclable HDPE #2 plastic.

NUMBER	DESCRIPTION	EACH
A51999-5014	Blue	\$62.99
A51999-2534	Dark Grey	62.99
A51999-7014	Green	62.99
A51999-4514	Orange	62.99
A51999-6004	Purple	62.99

C Whitney Brothers® 24-Cubby Tower

When floor space is limited, the 24-Cubby Tower provides plenty of storage within a small footprint. Made of high-quality birch laminate and featuring a tip-resistant design, the tower is a vertical, visible storage solution for classrooms and studios. It includes 24 clear plastic bins for storage and four casters for easy mobility. Measures 41"H x 28-1/2"W x 24"D. Truck Shipment and FOB Factory. See page 648 for details.

NUMBER	DESCRIPTION	SIZE	EACH
AF52107-1024	Tower	41"H x 28-1/2"W x 24"D	\$1025.00
AF52107-1000	Replacement Tray	5-1/2"H x 10-1/2"W x 13"D	18.89

D Whitney Brothers® Deluxe Mobile Art Supply Cart

This cart has a variety of compartments for all of your classroom art supplies! Store papers, books, bottles of paint, and more in shelves, cubbies, slotted shelves, and doweled compartments. It has heavy-duty, non-marking casters to easily roll it wherever you need it. Made from Baltic birch laminate, it weighs 108 lb and measures 33"H x 24-1/4"W x 33"D.

NUMBER	EACH
A52329-1001	\$759.00

E Whitney Brothers® Communication Center

This cabinet holds 20 clear plastic trays, which are perfect for corraling notes, artwork, communication between teachers and parents, and more. Adhere nametags to the outside of the trays to keep each student organized. Made of beautiful, sturdy birch laminate with casters for mobility. Measures 42"H x 27"W x 18"D. Truck Shipment and FOB Factory. See page 648 for details.

NUMBER	EACH
AF52321-1001	\$657.00

F Whitney Brothers® Rolling Art Cart

A great, mobile solution for classroom clutter. Featuring birch plywood construction, the cart has sectioned shelves on two sides for storing paper and supplies. A third side contains a deep bay for storing larger supplies and paper rolls. Measures 33"H x 30"W x 24"D. FOB Factory. See page 648 for details.

NUMBER	EACH
AF52107-1001	\$612.00



Blick® Studio Children's Tabletop Easel

Our fun, colorful, two-sided easel features a dry-erase board on one side and a chalkboard on the other. A built-in hanging rod holds a roll of paper that threads through the top. The kid-friendly, birch plywood frame has safe, smoothly sanded edges and tough plastic accents in three bright colors. Folding design has an integrated carry handle. 17"H x 17"W x 12-1/2"D when open. Weighs 5.5 lb. One paper roll included.

NUMBER	COLOR	EACH	6/EA
A50427-4860	Blue	\$37.65	\$33.89
A50427-3060	Pink	37.65	33.89



Blick® Studio Adjustable Activity Easel

Designed for young artists, this height-adjustable easel grows with kids. It also converts to a tabletop easel. Use it with chalk on one side and dry-erase markers on the other. An 18" x 25 ft paper roll is included too for painting and drawing. Two large trays and three convenient fabric storage bins corral supplies. Measures 26-1/4"W x 23"D and adjusts from 46" to 54" high.

NUMBER	EACH	6/EA
A50423-1003	\$110.89	\$99.81



Blick® Essentials Paint & Draw Easel

Draw, paint, and create with this 3-in-1 easel. It's double-sided, with a chalkboard on one side and a dry-erase board on the other. Feed the included 18" x 20 ft paper roll through the top of the easel for a third creative surface. Large trays hold supplies. Measures 43"H x 22"W x 19-1/2"D.

NUMBER	EACH	6/EA
A50423-1002	\$44.98	\$40.48



B



C



D



F



E



Copernicus® Deluxe Chart Stand

Unique and compact, this tabletop easel makes an ideal literacy center for one-to-one instruction. It's especially well-suited for making lessons more accessible to children with special needs. It features two magnetic dry-erase boards (one with 1" spaced blue lines) and comes with three removable tiny tubs and a detachable pocket chart that helps aid language development in the primary classroom. 19"H x 19"W x 17"D.

NUMBER	EACH
A51743-1010	\$273.33



Copernicus® Double-Sided Bamboo Easel

As eco-friendly as it is versatile this traditional teaching easel doubles as a magnetic dry-erase board. It has an easel on each side, four sliding storage tubs, and a ledge for supplies. It rolls effortlessly on four covered casters. Measures 54"H x 30"W x 25"D and weighs 55 lb.

NUMBER	EACH
A50424-1001	\$475.00



G-I Jonti-Craft® Easels

Kids can make art at the height that's ideal for them with this portable tabletop easel. They have multiple painting stations, so more than one kid can create at the same time. Easel features a maple frame and hardboard panels, plus clips for holding paper in place. Measures 24"H x 24"W and includes a paint tray. Folds flat for easy storage. Assembly is required. Optional acrylic chalkboard and dry-erase panels are available. Lifetime warranty. FOB Factory. See page 648 for details.

NUMBER	DESCRIPTION	EACH
AF50418-1001	G Tabletop Easel	\$160.07
AF50418-1005	Acrylic Panel	51.32
AF50418-1006	Chalkboard Panel	43.30
AF50418-1007	Dry Erase Panel	37.28

4-Way Adjustable Easel — Panels on each side of this easel adjust from 36" high to 46-1/2" high. FOB Factory. See page 648 for details.

NUMBER	EACH
AF50418-1004	\$464.00

2-Station Easel — Ideal for older school-age kids, this easel is 53-1/2" H x 25 1/2" W x 20" D overall.

NUMBER	EACH
A50418-1002	\$531.00

STEAM = Science & Technology interpreted through Engineering & the Arts, all based in Mathematical elements.



STEAM brings the real world into the classroom by teaching how all things relate to each other.

As the A in STEAM, art promotes inventive, creative thinking that students can apply to science and math projects — improving an engineering design, creating computer graphics, and more. Through art, math and science are more hands-on.

A Whitney Brothers® STEM Activity Desk and Mobile Seating Storage Bins

This innovative desk has room for two students. Its three-shelf center console includes two Grattnell trays. The desk has a non-ghosting markerboard surface and a lip around the top perimeter. It weighs 132 lb and measures 24"H x 19-1/2"W x 18-1/2"D overall. The cushioned seat lifts off to reveal a storage compartment. The seat also has rugged, lockable, non-marking 2" diameter casters and a removable whiteboard. It weighs 24 lb and measures 16-1/2"H x 14-3/4"W x 18-1/2"D overall.

NUMBER	EACH
A51783-1009	\$788.00



B-C Copernicus® Reading & Writing Centers

An essential teaching tool for primary and junior high classes, these learning centers are designed to help make lessons engaging and keep teachers organized. The carts include a premium book ledge, four sliding storage tubs, sturdy 3" locking casters, and more. They measure 57"H x 31"W x 32"D overall. For details, visit DickBlick.com. FOB Factory. See page 648 for details.

B Regal™ — Features a front magnetic dry erase surface (29"H x 29"W) and a rear removable dry erase board (23-3/4"H x 31-1/4"W) that hangs landscape.

NUMBER	EACH
AF52008-1020	\$341.00

Royal® — Features a front magnetic dry erase surface (29"H x 29"W) and a rear removable double-sided dry erase board (25"H x 36"W) with lines on one side. FOB Factory. See page 648 for details.

NUMBER	EACH
AF52008-1010	\$461.00

C Library On Wheels — Measures 40"H x 43"W x 18"D and features a 1" diameter steel frame and four 5" heavy-duty casters (two locking). Includes nine large, divided book tubs measuring 15"L x 12"W x 6"D with adhesive labels.

NUMBER	EACH
A52008-1050	\$478.00

D Copernicus® Early Learning Station

Ideal for pre-school through first-grade students, the Copernicus Early Learning Station is the perfect size for young, eager learners. It's great for hands-on activities that utilize big books and students' all-time favorite stories. Features of the Early Learning Station include two magnetic whiteboards (one lined), a roll-up felt board with corner ties and magnets, a Snap-On pad of chart paper, two tubs, and accessory hooks. Other features include a locking, adjustable Big Book ledge with Safety Caps, and four locking casters for mobility and stability. Measures 48"H x 25"W x 28"D.

NUMBER	EACH
A51743-1040	\$308.00

E Copernicus® STEAM Maker Station

Allows classrooms to store all of their essential "maker" materials in one secure place and share a unit between classrooms. Two models available: Base Model and Premier Model. Both feature a media storage rack, tape/ribbon/string dispenser, an overhead sign/display area, hanging hooks, power strip, and 4" locking casters. 56"H x 47"W x 27"D. FOB Factory. See page 648 for details.

Base Model — Includes four small tubs, four open tubs, and four tiny tubs.

NUMBER	EACH
AF46926-1001	\$695.00

Premier Model — Includes Tech Tub™ for locking up electronic equipment and mobile devices, a whiteboard for collaborative brainstorming, pegboard for tool storage, four small tubs, three open tubs, and four tiny tubs. FOB Factory. See page 648 for details.

NUMBER	EACH
AF46926-1002	\$785.00



Regal™ model



DAYLIGHT™



Daylight™ Techne™ Artist & Drafting Lamp

Specifically designed to easily mount on any type of easel, table, or board, this lamp comes with two interchangeable clamps for maximum versatility. Point the light exactly where you need it with 360° shade rotation and a 320° swiveling head-flip system. Bright Daylight LEDs (6,000K) with three brightness settings. The arm reaches up to 20-1/2". Brushed steel finish.

NUMBER	EACH	4/EA
A46941-1001	\$228.81	\$205.99



Daylight™ Naturalight™ LED Magnifying Lamp

This lamp's 5" diameter glass lens provides 1.75X magnification, so close-up tasks like drawing, painting, and crafting are easier. The dimmable lamp features LEDs with a color temp of 6,000K and two brightness settings. Easily move the adjustable arm (44" fully extended) to position light right where you need it. Clamp base.

NUMBER	EACH	6/EA
A55191-1025	\$159.84	\$143.90



Daylight™ Artists' Studio Lamp

With a sturdy tripod base and super bright reflector shade, this lamp casts a wide glow — ideal for large spaces and artists who work on a grand scale. The powerful 32W Daylight bulb reduces eyestrain and glare while allowing for true color matching.

NUMBER	DESCRIPTION	EACH	6/EA
A49601-1010	Studio Lamp with Stand	\$184.69	\$166.20
A49601-1001	LED Bulb	26.11	23.50

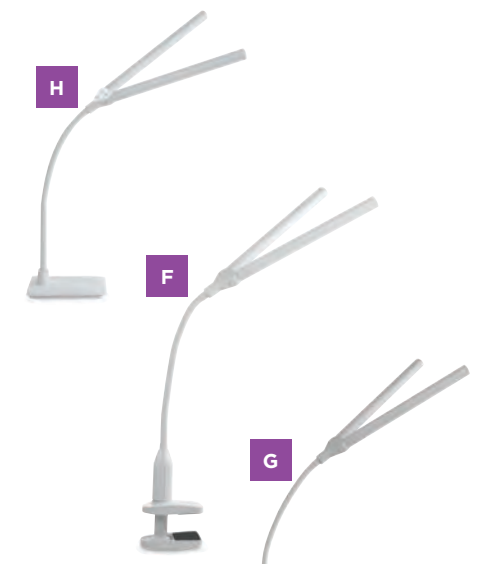

Daylight™ Combo Lamp

Use the right light for the project! Choose the 28W energy-saving Daylight tube setting (equivalent to 150W) for perfect color-matching, the 100W incandescent setting for a warmer light, or both together for even more flexibility. (Incandescent bulb not included.) Lamp has a durable metal arm with internal springs. Use the clamp to attach it to desks, easels, and more. 30" high when fully extended.

NUMBER	EACH	6/EA
A55187-1001	\$149.70	\$134.70

F-H Daylight™ DuoLamp and UnoLamp

Double your lighting possibilities! The DuoLamp features two independently adjustable shades, allowing you to spread light over a very wide area or focus intense light over a small area. Tap the touch-switch dimmer to adjust the lamp's brightness. Energy-efficient LEDs provide accurate color matching.

NUMBER	DESCRIPTION	EACH	6/EA
A49661-1001	F Clamp	\$84.14	\$75.74
A49661-1003	G Floor	105.66	95.10
A49661-1002	H Table	84.14	75.74

UnoLamp — Same features as the DuoLamp, but one light.

NUMBER	DESCRIPTION	EACH	6/EA
A49662-1001	Clamp	\$58.11	\$52.30
A49662-1003	Floor	74.41	66.98
A49662-1002	Table	58.11	52.30

For more styles, visit DickBlick.com.

Daylight™ Slimline 3 LED Lights

See details clearly under light cast by the Slimline. Its 80 daylight LEDs emit up to 3,000 LUX. Features include an aluminum shade with a diffuser, four brightness settings, and a flexible arm that rotates 360°.

NUMBER	COLOR	EACH	4/EA
A49669-1002	Chrome	\$198.21	\$178.40
A49669-1001	Chrome, Floor Lamp	256.51	230.90
A49669-1003	Rose Gold	198.21	178.40



Daylight™ Smart Clip-On Lamp

Light on the go! This extra-lightweight travel lamp is just 0.3 lb and easily attaches to an easel, sketchbook, or drawing board. It runs up to four hours on a rechargeable battery. Plug it into your laptop, phone charger, or other USB-compatible power supply to recharge. Daylight LEDs provide high contrast and accurate color matching. Three brightness levels. 4-3/4" x 2-1/4" clip base with a flexible 14" neck.

NUMBER	EACH	6/EA
A46939-1020	\$36.93	\$33.24



Studio Designs™ LED Bar Lamp

This lamp is powered by a USB cable — simply connect it to any laptop, computer, or digital device with a USB port and bring the light wherever you roam. It also includes an AC adapter that allows you to use it with a conventional power outlet. 12" light bar has 28 LED bulbs and a 17-3/4" flexible neck for easy adjustment.

NUMBER	COLOR	EACH	6/EA
A55815-2050	Black	\$47.69	\$42.92
A55815-9330	Silver	47.69	42.92



Studio Designs™ Swing Arm Lamp

A versatile, all-around lamp for creative environments. Its flexible arm extends to 36" and its clamp attaches easily to almost any art table. The spring and tension control knobs are made of steel for extra durability. This lamp is UL-approved for use with a 13W CFL bulb (included) or 100W incandescent bulb (not included). 6-1/2" diameter shade.

NUMBER	COLOR	EACH	6/EA
A49650-2020	Black	\$42.24	\$38.03
A49650-1020	White	42.24	38.03



Studio Designs™ Magnifier Lamp

Features a high-quality glass lens with 3 diopter magnification that brings tiny details into sharp focus. Flip the switch to shed bright, incandescent light on the object in view, and use the 36" flexible arm to get the perfect angle on your project. Clamp mount base. Uses one 60W bulb (not included).

NUMBER	EACH	12/EA
A49649-1000	\$50.45	\$45.41



Studio Designs™ Art Clamp Lamp

Offers a sleek, contemporary look along with the modern convenience of a USB plug that lets you power it with any computer, laptop, or digital device. Bright, diffused light is emitted by 20 LED bulbs, while a 13-1/2" flexible neck lets you direct it exactly where it's needed. The strong clamp mount is padded to prevent damage to furniture surfaces. A standard AC adapter is included.

NUMBER	COLOR	EACH	6/EA
A56550-2020	Black	\$41.14	\$37.03
A56550-1020	White	41.14	37.03



Ultra Optix™ Lighted Magnifier

Enlarge small type and intricate craft projects easily and conveniently. Lighted, handheld magnifier is 5" in diameter with a 2X power scratch-resistant, shatterproof lens and a built-in 6X bifocal insert. Uses one AAA battery (not included).

NUMBER	EACH	6/EA
A55215-0005	\$36.75	\$33.08

Chromalux™ Incandescent Bulbs

Made specifically for arts and crafts. Frosted blue. 3200K light temperature. Rated to last 5,000 hours.

NUMBER	DESCRIPTION	EACH	12/EA
A55114-1000	100W	\$12.24	\$10.99
A55114-1250	150W	8.73	7.85



Chromalux™ Aluminum Light Stand

Heavy-duty aluminum 10" diameter reflector swivels to all angles. Sturdy three-section stand extends to 7 ft tall and folds for storage. Perfect for use with Chromalux bulbs, sold separately below.

NUMBER	EACH	3/EA
A55117-0000	\$98.93	\$89.05



Chromalux™ Full-Spectrum Halogen Flood Bulbs

The most natural light indoors! With a color temperature of 4200K, these bulbs are calculated to be the closest simulation to daylight — perfect for mixing colors, illuminating a canvas during painting, and for model or subject lighting. Rated to last 3,500 hours.

NUMBER	DESCRIPTION	EACH	12/EA
A55114-1175	75W	\$27.95	\$25.15
A55114-1100	100W	17.58	15.82



Plastic Fold-Up Magnifier

Linen tester loupe has 5X magnification with inch and metric scales. Portable and foldable. Perfect for fabric count, photography, stamps, coins, and artwork.

NUMBER	EACH	6/EA
A55219-1005	\$7.71	\$6.94

Make a healthy choice for your eyes. Lights in the OttLite Wellness Series contain ClearSun LEDs, which reduce eyestrain by up to 51%. They imitate natural daylight and have a color rendering index of 97.



OttLite™ LED Revive Lamp

This elegant metal lamp features touch-activated controls to change the light's brightness and a USB charging port. It's height-adjustable from 5-1/2" to 24" and has a 7" base diameter.

NUMBER	DESCRIPTION	COLOR	EACH	6/EA
A46955-5110	Table Lamp	Turquoise	\$76.27	\$68.65
A46955-1020	Table Lamp	White	76.27	68.65
A46955-1021	Floor Lamp	White	127.10	114.40



OTTLITE®



D OttLite™ Creative Curves LED Desk Lamp

This lamp has a sleek, rubberized flex-neck extends 20" and adjusts in height from 11-1/4" to 23-3/4". Its natural daylight LEDs last up to 40,000 hours and emit a maximum of 375 lumens. Choose from four brightness settings. A diffuser provides smooth, uniform light. Plugs into a standard 120V outlet. Its base is 5-1/4" in diameter.

NUMBER	COLOR	EACH	6/EA
A46935-2020	Black	\$36.51	\$32.85
A46935-1020	White	36.51	32.85



E OttLite™ SlimLine Task Lamp

This compact lamp puts the light where you need it, with 508 Illumination™ for a precise balance of contrast and brightness. The low-heat 13W bulb reduces eyestrain and lasts 10,000 hours.

NUMBER	COLOR	EACH	3/EA
A55196-2040	Black	\$44.47	\$40.03



F OttLite™ LED Task Light

Collapsible, lightweight, and equipped with a carrying handle for easy portability. 30 OttLite LED bulbs cast a bright glow and last up to 40,000 hours. Three AA batteries or AC adapter required (neither included).

NUMBER	COLOR	EACH	6/EA
A55824-2050	Black	\$33.06	\$31.49
A55824-1040	White	33.06	31.49



G OttLite™ Dual Shade LED Floor Lamp with USB Charging Station

This multi-functional lamp has two pivoting heads, a USB charging station, and an adjustable stand to hold your tablet or smartphone. Its super-bright LEDs emit a maximum of 1,175 lumens and last up to 40,000 hours. The 12-1/2" long shades move on a flexible gooseneck. Its base measures 12-1/2" x 8".

NUMBER	EACH	6/EA
A46937-1020	\$176.37	\$158.80

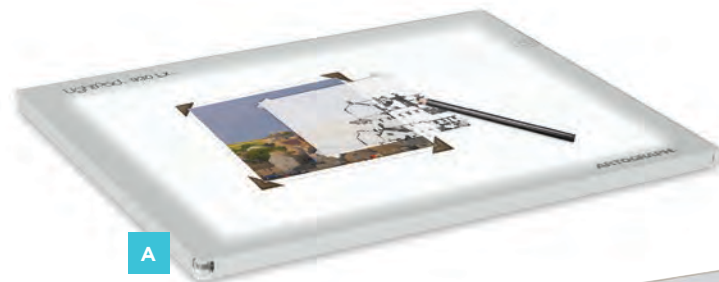

A

A Artograph® LightPad® LX™ LED Light Box

Super-bright, maintenance-free LEDs provide cool, even illumination and last up to 50,000 hours. Dim or brighten them to suit your needs.

Work surface is double-layered for firmness and encased in a durable extruded aluminum frame. Trim 1/2" profile. Includes an AC adapter, a power supply, and a protective storage sleeve.

NUMBER	SIZE	EACH
A55337-1021	6" x 9"	\$123.94
A55337-1023	9" x 12"	152.42
A55337-1012	12" x 17"	265.83
A55337-1024	17" x 24"	371.00



C



B

B Litebox® Model 3200

With three 20W, color-corrected bulbs and an oak-look laminate frame, this light box is both functional and attractive. Adjustable feet let you tilt it up to 15° for an easier viewing angle. Measures 18" x 24". 5000°K color temperature.

NUMBER	EACH
A55305-1009	\$492.00

20W Replacement Bulb

NUMBER	EACH	6/EA	12/EA
A55305-0100	\$26.39	\$23.60	\$22.40

C Litebox® Lumina

The large 18" x 24" viewing area is ideal for viewing transparencies, slides, and color separations, and for doing layouts, overlays, calligraphy, tracing, and more. Three 20W fluorescent bulbs provide excellent simulated daylight illumination with no hot spots. Made of white laminate with a thick, frosted acrylic top.

NUMBER	EACH
A55305-2009	\$219.49



F

F Gagne® Porta-Trace® Oak Frame LED Light Box

All the same specifications as Porta-Trace boxes with stainless steel frames (left) but with a beautifully finished, 5/8" thick solid oak frame.

NUMBER	SIZE	BULBS	EACH
A55349-1214	12" x 14"	6 LED Modules	\$214.43
A55349-1118	11" x 18"	12 LED Modules	335.00
A55349-1618	16" x 18"	12 LED Modules	433.00
A55349-1824	18" x 24"	21 LED Modules	644.00

E Gagne® Porta-Trace® Stainless Steel LED Light Box

Boasting a stainless steel frame, an aluminum chassis, and a shatter-resistant opal 1/4" thick Plexiglas® top, these light boxes offer maximum light diffusion, minimum glare, and no hot spots. LED lamps provide excellent graphic arts-quality color while saving energy. Rust-resistant. (Sizes 10" x 12" and 11" x 18" don't have handles.) 3" profile.

NUMBER	SIZE	BULBS	EACH
A55348-1123	10" x 12"	3 LED Modules	\$77.91
A55348-1128	10" x 12"	8 LED Modules	169.98
A55348-1118	11" x 18"	12 LED Modules	173.91
A55348-1618	16" x 18"	21 LED Modules	422.00

Porta-Trace with Tilt Adjustment

NUMBER	SIZE	BULBS	EACH
A55348-1009	18" x 24"	21 LED Modules	\$605.00
A55348-1015	24" x 36"	44 LED Modules	887.00



D

D Gagne® Porta-Trace® LED Light Table

With its shatter-resistant, opal 1/4" thick Plexiglas® top, this light table gives maximum diffusion of light with minimum glare and no hot spots. It has a solid oak frame with an adjustable tilt and is mounted on steel legs with a white baked enamel surface. Illuminated by energy-saving LED lights, it provides excellent color quality.

NUMBER	SIZE	BULBS	EACH
A55358-1015	24" x 36"	44 LED Modules	\$1903.00
A55358-1027	36" x 48"	88 LED Modules	3054.00



G



H



I

4" legs

G Gagne® Porta-Trace® Lumen Series LED Light Panel

Get the bright, uniform light you expect from a Gagne light box — without the bulky frame. This frameless, ultra-thin light panel is just 1/2" thick. Embedded LEDs (rated to last 50,000 hours) provide super bright, even lighting. Secure images or photos under the panel's removable acrylic face while tracing. 1" legs included. Made in the USA.

NUMBER	SIZE	EACH
A55365-1069	6" x 9"	\$97.04
A55365-1011	8" x 11"	109.67
A55365-1018	11" x 18"	153.63

4" Legs, Set of 2 — Use these legs to set the panel upright or position it at a slant.

NUMBER	EACH
A55365-1449	\$24.03

H Gagne® Porta-Trace® LED LightPanel

Whiter, brighter, and the best value available. This unit is great for sketching and rendering, backlit display, engineering and architectural drawings, embossing, inspection, quilting, and tattoo transfer. Its eco-friendly design features long-lasting LED lights with an estimated life of 50,000 hours.

NUMBER	SIZE	EACH
A55338-1011	8-1/2" x 11"	\$192.17
A55338-1018	11" x 18"	340.00
A55338-2056	16" x 18"	444.00

I Daylight™ Wafer LED Light Box

Just 3/8" thick, the Wafer is ultra thin, ultra light, and ultra easy to transport. It also boasts fully dimmable LED lights for a bright, even spread of illumination from edge to edge. It's completely smooth and frameless, so your project lies flat and won't get hung up on edges. The border is marked with a US/metric grid for easy measuring. AC adapter included.

NUMBER	SIZE	EACH
A55347-1003	9" x 12"	\$177.97
A55347-1001	11" x 17"	281.43
A55347-1002	18" x 23-1/2"	341.00



Savage® Lit Pro LED Light

Create a soft, even, low-shadow softbox effect. Features all metal construction and an LCD readout with power level, color temperature, and channel information. The LEDs emit 60 watts of light. Comes with a rotating light stand adapter, a multi-channel remote control, two Sony NP-F750 batteries with a charger, an AC power cord, and a padded carry bag for easy transport.

NUMBER	DESCRIPTION	EACH
A46958-1001	Edge Light	\$358.00

Edge Lit Pro LED Light Kit — This kit includes two 12" x 9" Edge Lit Pro LED Lights, two rotating light stand adapters, two 7 ft easy-op drop stands, a multi-channel remote control, four Sony NP-F750 batteries with chargers, and two AC power cords, all packaged in a padded rolling case.

NUMBER	EACH
A46958-1002	\$925.00



Savage® Solid Muslin Backdrops

Create smooth backgrounds for portraits, product shots, group photos, video productions, and more. They're crafted from extra durable, non-reflective, 100% cotton with seamless construction. The 3" rod pocket allows for easy hanging. The material is made with a dye layering technique that creates vibrant colors with excellent depth and is perfect for images requiring clean, clear backgrounds.

NUMBER	COLOR	SIZE	EACH
A49818-2021	Black	10 ft x 12 ft	\$74.38
A49818-2022	Black	10 ft x 24 ft	134.12
A49818-7491	Chrome Green	10 ft x 12 ft	74.38
A49818-7492	Chrome Green	10 ft x 24 ft	134.12
A49818-2501	Solid Gray	10 ft x 12 ft	74.38
A49818-2502	Solid Gray	10 ft x 24 ft	134.12
A49818-1021	White	10 ft x 12 ft	74.38
A49818-1022	White	10 ft x 24 ft	134.12

Got a question about a product? Our experts have the answer! Three ways to connect — Live Chat at DickBlick.com, call 800.933.2542, or email info@DickBlick.com.



new!



Expo® Low Odor Dry Erase Markers

Use Expo Low Odor Dry Erase markers to track, schedule, and present your point in a brilliant fashion. Intense colors can easily be seen from a distance and erase easily from marker boards. Specially formulated low odor ink is ideal for classrooms, small offices, and homes. Certified AP non-toxic and conforms to ASTM D-4236.

Ultra Fine Tip			EACH	12/EA
NUMBER	DESCRIPTION	SET		
A21325-1089	Assorted	Pkg of 8	\$13.42	\$12.09
A21325-1209	Assorted	Pkg of 4	12.77	10.91

Fine Tip			EACH	12/EA
NUMBER	DESCRIPTION	SET		
A52922-2024	Black	Each	\$1.90	\$1.70
A52922-1049	Assorted	Pkg of 4	7.12	6.39
A52922-1129	Assorted	Pkg of 12	22.66	20.40

Chisel Tip			EACH	12/EA
NUMBER	DESCRIPTION	SET		
A52922-2004	Black	Each	\$1.99	\$1.76
A52922-5014	Blue	Each	1.99	1.76
A52922-7014	Green	Each	1.99	1.76
A52922-6004	Purple	Each	1.99	1.76
A52922-3014	Red	Each	1.99	1.76
A52922-0429	Assorted	Pkg of 4	6.34	5.71
A52922-1229	Assorted	Pkg of 12	26.30	23.69
A52922-1169	Assorted	Pkg of 16	34.23	30.82

Bullet Tip			EACH	12/EA
NUMBER	DESCRIPTION	SET		
A52922-1149	Assorted	Pkg of 4	\$6.34	\$5.71

Expo® Dry Erase Cleaners

Restore dry-erase surfaces to near their original brilliance! Expo Dry Erase Cleaners quickly and easily erase marks and ghosting from most dry-erase surfaces. Simply wipe with an Expo eraser, apply Expo Spray Cleaner, and clean with a soft cloth. Choose Expo Cleaning Wipes for removing stubborn marks, ghosting, grease, stains, and shadowing. The airtight pop-up container holds 50 pre-moistened, ready-to-use towelettes.



NUMBER	DESCRIPTION	EACH	12/EA
A22103-1005	Original Cleaner, 8 oz Spray Bottle	\$4.41	\$3.97
A22103-1009	Original Cleaner, Gallon Refill	34.64	31.17
A22103-1001	Cleaning Towelettes	11.14	10.03



I-K Expo® Dry Erase Accessories

Specially designed to erase and maintain your melamine, whiteboard, or porcelain dry-erase boards, these erasers have soft pile surfaces that trap marker residue and dust.

NUMBER	DESCRIPTION	EACH	6/EA
A22844-1010	I Eraser	\$9.30	\$8.38
A22844-1020	J Eraser Refill	4.27	3.84
A22844-1060	K Block Eraser	4.43	3.99



A NEW! Savage Product Pro LED Light Table

Brightly illuminate small subjects with minimal equipment. For more details, visit DickBlick.com.

NUMBER	EACH
A46942-1122	\$393.00

B Savage® Vlogger LED Ringlight

Create soft, even lighting for photos and videos. For more details, visit DickBlick.com.

NUMBER	EACH
A46956-1005	\$81.89

C Savage® 700 Watt LED Studio Light Kit

Everything you need for consistent lighting, including two energy-efficient, dimmable LED chip bulbs, which each generate the equivalent of 350W. For more details, visit DickBlick.com.

NUMBER	EACH
A46943-1007	\$211.43

D Savage® Wrinkle-Resistant Economy Solid Background Kits

Easily create a professional backdrop. These kits contain one 5 ft x 9 ft matte polyester backdrop, a backdrop stand that opens to 91"H x 124"W and collapses to 47" high, and a carry bag.

NUMBER	COLOR	EACH
A49814-2020	Black	\$94.97
A49814-2500	Gray	94.97
A49814-7010	Green	94.97
A49814-1020	White	94.97

E Savage® 5 in 1 Reflector

Control ambient and studio lighting. The translucent reflector includes two sleeves — white/black and gold/silver — that offer a variety of effects to achieve a desired look. For more details, visit DickBlick.com.

NUMBER	EACH
A49827-1001	\$26.49



F Savage® Luminous Pro LED Ringlights

Achieve soft, even lighting in photos and videos. Savage ringlights provide a catch light to draw attention to the subject's eyes and create a luminous look.

LED-RLPS Luminous Pro LED Ringlight Plus — For contents, visit DickBlick.com.

NUMBER	EACH
A46956-1002	\$337.00

Ringlight Beauty Video Kit — For kit contents, visit DickBlick.com.

NUMBER	EACH
A46956-1003	\$464.00

Savage Drop Stands — Three-section, all aluminum construction with durable aluminum collars. Reversible 1/4"-20 to 3/8" stud adapter included.

NUMBER	SIZE	EACH
A49817-1001	7 ft	\$67.83

NUMBER	SIZE	EACH
A49817-1002	9 ft	\$101.75

G Crayola® Take Note!™ Dry-Erase Markers

Crayola Take Note! Dry-Erase Markers are quick to dry but easy to erase. Their vibrant colors are great for making bold messages that can be seen on most white boards anywhere in the room. Available in both chisel tip and fine tip styles, they have a user-friendly formulation and design, plus a low-odor formulation that makes them pleasant to use in close quarters. A handy ink level indicator lets you know when your ink is running low.

NUMBER	DESCRIPTION	EACH	12/EA
A22380-1001	4 Colors, Fine Line	\$4.92	\$4.43
A22380-1003	4 Colors, Chisel	4.92	4.43
A22380-1004	12 Colors, Chisel	14.83	13.35

H Crayola® Dry-Erase Crayon Sets

Great for kids, with no odor, no caps to lose, and bold, opaque colors that erase cleanly with E-Z Erase Mitt but won't brush off dry-erase surfaces. Crayon washes easily from skin and fabrics. Classic Colors set includes eight large-size crayons in Red, Blue, Green, Orange, Yellow, Purple, Brown, and Black, and a built-in sharpener. For contents of Bright Colors set, visit DickBlick.com.

NUMBER	DESCRIPTION	EACH	12/EA
A67815-1008	8 Classic Colors	\$5.11	\$4.60
A67815-2008	8 Bright Colors	5.11	4.60

The Pencil Grip™ Whiteboard Erasers

A must have for classrooms, The Pencil Grip Whiteboard Erasers keep whiteboards clean and reduce allergens in the air. Their unique design allows the top layer to be peeled off to expose a fresh, new cleaning surface.

Personal Eraser — Measures 2" x 2" and has 15 peel-away layers, great for individual use.

NUMBER	EACH	12/EA
A22370-5012	\$1.63	\$1.46

Desktop Eraser — Measures 4-1/2" x 1-3/4" and has seven peel-away layers, perfect for desktop use.

NUMBER	EACH	12/EA
A22370-5011	\$1.63	\$1.46



Expo® 2-in-1 Dry Erase Markers

One marker, two colors! Expo 2-in-1 Dry Erase Markers are great for making presentations, drawing flow charts, and making notes on whiteboards, glass, and other non-porous surfaces. The versatile chisel tip makes broad, medium, or fine lines — you choose! Their low odor formula makes them pleasant to use in confined spaces. For set colors, visit DickBlick.com.

NUMBER	SET	EACH	6/EA
A22355-1049	4-Count/8 Colors	\$12.75	\$11.47
A22355-1069	6-Count/12 Colors	19.19	17.27
A22355-1089	8-Count/16 Colors	24.69	22.23



A Projection Screen

Ideal for the classroom or office, this screen has a flame-retardant, mildew-resistant matte white surface and black border. Perfect for computer, video, slide, and overhead projections. Keystone eliminator neutralizes picture distortion. Rugged metal case withstands abuse. Sets up in seconds. Truck Shipment and FOB Factory. See page 648 for details.

NUMBER	SIZE	EACH
AF51117-1060	60" x 60"	\$401.00
AF51117-1070	70" x 70"	603.00

B Horizon 2 Overhead Projector

Ideal for use in classrooms and small groups up to 20 people, the Horizon 2 is a reliable, easy-to-use projector that features 2000 lumen output, a high-efficiency cooling system, and a thermal shutoff safety switch. An open head with double fresnel lens assures edge-to-edge sharpness and brightness, and a lamp control adapts light for bright or dark presentations. 10" x 10" stage. Head folds or stores away. Weighs 12 lb. Two-year limited warranty. FOB Factory. See page 648 for details.

NUMBER	EACH
AF53032-2000	\$528.00

Replacement Bulbs — Made from 99% pure quartz glass, these replacement bulbs provide super-bright light, long life, and accurate color. They fit most overhead projectors. FOB Factory. See page 648 for details.

NUMBER	EACH
AF53020-1006	\$49.65



Apollo Transparency Film

Create and present crisp charts, graphs, and spreadsheets on your laser printer, inkjet printer, or copier. Specially coated, clear transparencies assure sharp black images within 8 1/2" x 11" non-stripped sheets. Eliminate the confusion over which film to use when you buy the Multipurpose Film. It's compatible with most systems. The Inkjet Film also produces brilliant color images.

NUMBER	STYLE	QTY/BOX	EACH	5/EA
A53107-1002	Laser Printers	50	\$64.99	\$58.50
A53107-1003	Plain Copier	100	54.89	49.40
A53107-1004	Multipurpose	50	123.52	111.16
A55816-1050	Write-On	100	39.67	35.71

new!



Flipside Single-Sided Dry Erase Answer Paddles

Get quick and quiet answers from the whole class with these fun dry-erase paddles. They're great for review sessions, games, lessons, and more. The durable hardboard backing is warp- and chip-resistant, so they'll stand up to repeated classroom use. Non-ghosting surface erases easily. Each paddle measures 9"H x 5"W x 1/4"D.



NUMBER	DESCRIPTION	EACH	12/EA
A52299-1012	Class Pack of 12	\$20.11	\$18.10
A52299-1024	Class Pack of 24	40.21	36.19

NEW! MasterVision Dry Erase Double Sided Lap Boards

Ideal for note taking, brainstorming sessions, classroom instruction, educational games, and more! The double sided, non-magnetic surface wipes clean. With rounded corners for safety, the lap board measures 9" x 12" and can be purchased individually or in packs of 10 or 30 for groups.

NUMBER	PKG	EACH
A03531-1023	1	\$5.99
A03531-1013	10	27.41
A03531-1033	30	68.55

IdeaPaint Pro Series Dry Erase Paint Kits

This commercial-grade, patented coating transforms any smooth surface into a high-performing dry-erase writing surface. Use it on doors, columns, in hallways, and more. Fully cures after seven days. Use with any standard dry-erase marker, dry-erase eraser, dry cotton cloth, micro-fiber towel, or cleaner. It won't crack, peel, stain, yellow, or fade. Formaldehyde-free and Greenguard certified.



NUMBER	COLOR	EACH
A50987-8160	Lt Beige	\$219.93
A50987-2510	Lt Grey	219.93
A50987-1040	White	219.93
A50987-1050	White Sand	219.93



Post-it Super Sticky Dry Erase Surfaces

Put a whiteboard anywhere! These instant, cut-to-fit sheets and rolls create writable surfaces on tabletops, walls, windows, and more. Use them to transform regular desks and walls into collaborative, interactive spaces. Installation is a breeze — just peel and stick. The stain-proof dry-erase surface writes smoothly and erases cleanly every time.

NUMBER	DESCRIPTION	SIZE	EACH	SALE
A52298-1003	Roll	2 ft x 3 ft	\$46.47	\$41.82
A52298-1004	Roll	3 ft x 4 ft	79.76	71.80



Expo Vis-a-Vis Projection Markers

Formulated for use on overhead transparencies. Brilliant, transparent colors are odorless, non-toxic, and may be washed off with a damp cloth.

Set of 8 — Includes Black, Red, Blue, Green, Orange, Brown, Yellow, and Purple.

NUMBER	EACH	12/EA	24/EA
A21343-0009	\$13.56	\$12.20	\$11.58

Individual Vis-a-Vis Markers — Colors can be assorted for quantity pricing.

NUMBER	COLOR	EACH	12/EA	24/EA
A21343-2001	Black	\$2.31	\$2.09	\$1.95
A21343-5001	Blue	2.31	2.09	1.95
A21343-7001	Green	2.31	2.09	1.95
A21343-3001	Red	2.31	2.09	1.95

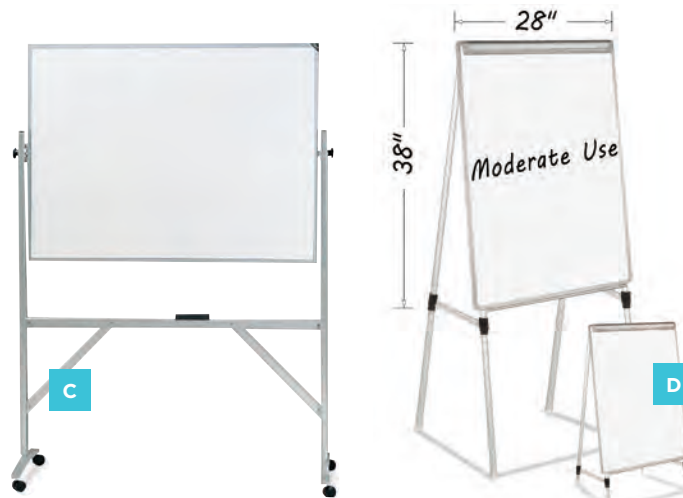

C Ghent Reversible Aluminum Frame Markerboards

Free-standing, double-sided acrylate markerboards feature aluminum frame construction for strength and durability. Reversing mechanism is specifically designed to make flipping to the other side easy. Full-length accessory tray and reinforced brackets reduce swaying. Locking casters included. Simple assembly required. Truck Shipment and FOB Factory. See page 648 for details.

NUMBER	WIDTH X HEIGHT	EACH
AF50950-1034	48" x 36"	\$699.00
AF50950-1046	72" x 48"	898.00

D MasterVision Dry Erase Quad-Pod Presentation Easel

This versatile, portable easel works great on the floor or on a tabletop thanks to its sturdy telescoping legs. Extend legs for floor use or collapse the legs and set it on a table. Support braces help prevent wobbling. The dry-erase board measures 40-1/2" x 28-1/2". Easel height ranges from 45" to 72". Base is 26"W x 18"D. Folds for easy transport and storage. FOB Factory. See page 648 for details.

NUMBER	EACH
AF50583-1001	\$167.81



U Brands Combo Dry Erase Boards

These boards feature a magnetic, highly durable dry erase surface and built-in, self-healing natural cork cork strips for writing memos, pinning invitations, and more. Each board includes a dry erase marker with an eraser and a magnet.

NUMBER	COLOR	SIZE	EACH
A03526-1108	Black	16" x 20"	\$16.49
A03526-1005	White	11" x 14"	10.99
A03526-1008	Silver/Black	16" x 20"	14.29



Ghent Dry Erase Markerboards

A great alternative to chalkboards. Dry-erase markers wipe away cleanly with a cloth, tissue, or felt eraser — no dust or mess. Each board includes a satin anodized aluminum frame, accessory tray, and attached hangers. Larger boards (72" x 48" and 96" x 48") come with a marker and eraser; smaller styles (48" x 36" and smaller) do not. •Requires truck shipment. FOB Factory. See page 648 for details.

White Non-Magnetic — These high-quality, non-magnetic whiteboards include a 10-year surface warranty.

NUMBER	WIDTH X HEIGHT	EACH	12/EA
AF50919-1009	24" x 18"	\$42.81	\$38.53
AF50919-1005	36" x 24"	50.52	45.47
AF50919-1301	•72" x 48"	249.99	224.99
AF50919-1501	•96" x 48"	298.81	268.94



White Porcelainized — Highest-quality porcelain on steel markerboard. These boards hold magnets. 50-year surface warranty. FOB Factory. See page 648 for details.

NUMBER	WIDTH X HEIGHT	EACH	12/EA
AF50919-1001	36" x 24"	\$169.87	\$152.88
AF50919-1201	•48" x 36"	293.03	263.75
AF50919-1401	•72" x 48"	447.00	402.00
AF50919-1601	•96" x 48"	527.00	475.00



Cintra Cork Boards

Add a modern touch to your classroom bulletin board displays! Satin-finish aluminum frame with gray plastic radius corners offers a sleek, contemporary look. Artwork and visual aids attach easily to the self-healing cork surface.

NUMBER	SIZE	EACH
A50977-1009	1-1/2 ft x 2 ft	\$77.77
A50977-1023	2 ft x 3 ft	101.20
A50977-1034	3 ft x 4 ft	166.79
A50977-1046	4 ft x 6 ft	290.48
A50977-1048	4 ft x 8 ft	436.00



NEW! MasterVision Wood Frame Cork Bulletin Boards

Plenty of space to tack up notes, lists, reminders, and photos! These convenient bulletin boards feature a thick, self-healing cork surface that resists pinholes, and a durable pine-finish MDF frame. Boards are available in three sizes, 12" x 18", 18" x 24", and 24" x 36". Mounting hardware included.

NUMBER	SIZE	EACH
A03533-1006	12" x 18"	\$10.99
A03533-1109	18" x 24"	15.39
A03533-1115	24" x 36"	26.39



NEW! MasterVision Chalkboard with Pine Wood Frame

Ideally sized for classrooms or offices, MasterVision Pine Wood Frame Chalkboards are as useful for drawing as they are for posting inspirational quotes, lists, reminders, and more. The classic black surface works great with chalk and liquid chalk markers and cleans easily with a cloth or felt eraser.

NUMBER	SIZE	EACH
A03530-1006	12" x 18"	\$18.43
A03530-1009	18" x 24"	26.73
A03530-1015	24" x 36"	39.64



Flipside Single-Sided Black Chalkboard Learning Boards

A classroom classic that helps save paper. This time-tested and reusable writing surface is great for handwriting practice, working equations, and more. The boards have rounded edges for safety and comfort, and a chip-and-warp-resistant hardboard backing for durability. Each board measures 9-1/2"H x 12"W x 1/8"D.

NUMBER	DESCRIPTION	EACH	3/EA
A03514-1012	Class Pack of 12	\$44.49	\$40.04
A03514-1024	Class Pack of 24	86.46	77.83



For more chalk, see page 306 or visit DickBlick.com.



Sargent Art® Chalkboard Chalk

This dustless, non-toxic chalkboard chalk is available in 12-count sets of White or an assortment of colors.

NUMBER	COLOR	EACH	12/EA	24/EA
A21924-0129	Assorted	\$1.50	\$1.36	\$1.28
A21924-1029	White	1.07	.97	.91



U Brands® Square Cork Bulletin Boards

A modern display for notes, invitations, memos, photos, and more. The boards firmly grip push pins in place. Each package includes of four, 12" x 12" frameless boards. Combine multiple boards to create the ultimate display.

NUMBER	EACH	12/EA
A03527-1001	\$8.47	\$7.62

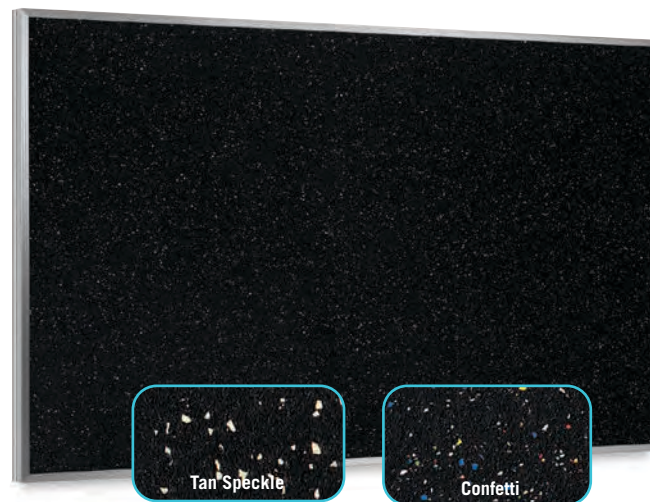

Ghent® Recycled Rubber Tackboards

Manufactured from 100% post-industrial material, the textured recycled rubber surface on these tackboards stands up to heavy use. It is fade-resistant, stain-resistant, colorfast, and self-healing — so it won't show pinholes no matter how much you tack to it! Available in Black, Confetti, and Tan Speckled, with an anodized satin aluminum frame. •Requires truck shipment. FOB Factory. See page 648 for details.

SIZE	BLACK	TAN SPECKLE	CONFETTI	EACH
46-1/2" x 36"	AF50978-2052	AF50978-8262	AF50978-1032	\$138.10
•60" x 36"	AF50978-2053	AF50978-8263	AF50978-1033	202.39
•48" x 48"	AF50978-2054	AF50978-8264	AF50978-1034	193.41
•60" x 48"	AF50978-2055	AF50978-8265	AF50978-1035	212.31
•72" x 48"	AF50978-2056	AF50978-8266	AF50978-1036	255.91
•92" x 48"	AF50978-2057	AF50978-8267	AF50978-1037	309.00
•120" x 48"	AF50978-2058	AF50978-8268	AF50978-1038	392.00
•144" x 48"	AF50978-2059	AF50978-8269	AF50978-1039	424.00



Ghent® Enclosed Natural Cork Bulletin Boards

These enclosed bulletin boards feature lockable hinged doors and shatter-resistant acrylic to keep your display clean and undisturbed. Natural cork posting surface is self-healing and withstands repeated tacking. The Natural Oak frame has a 1-1/4" interior depth and a 2-1/4" overall depth. Available in single door, two door, or extra wide three door versions. •Requires truck shipment. FOB Factory. See page 648 for details.

NUMBER	WIDTH X HEIGHT	DOORS	EACH
AF50949-1018	18" x 24"	1	\$250.37
AF50949-1024	24" x 36"	1	330.00
AF50949-1048	48" x 36"	2	520.00
AF50949-1060	60" x 36"	2	603.00
AF50949-1072	•72" x 36"	3	904.00



Ghent® Cork Boards

Whether you choose satin-finish aluminum or a natural-finish oak frame, you can't go wrong with these open-face cork boards. Made with finest-quality, self-sealing cork, they feature concealed hangers for wall mounting and are reinforced with sturdy back panels. Subtract width of frame from overall dimensions for usable space. •Requires truck shipment. FOB Factory. See page 648 for details.

Aluminum Frame			
NUMBER	WIDTH X HEIGHT	FRAME WIDTH	EACH
AF50924-1001	36" x 24"	1/2"	\$49.32
AF50924-1021	46-1/2" x 36"	1/2"	82.73
AF50924-2041	•60" x 36"	3/4"	150.35
AF50924-2101	•72" x 48"	3/4"	194.11
AF50924-2121	•96" x 48"	3/4"	246.61
AF50924-2081	•120" x 48"	3/4"	294.34
AF50924-2091	•144" x 48"	3/4"	349.00

Wood Frame — FOB Factory. See page 648 for details.

NUMBER	WIDTH X HEIGHT	FRAME WIDTH	EACH
AF50924-1011	36" x 24"	1/2"	\$82.98
AF50924-1031	46-1/2" x 36"	1/2"	126.60
AF50924-2051	•60" x 36"	3/4"	213.83
AF50924-2111	•72" x 48"	3/4"	255.32
AF50924-2131	•96" x 48"	3/4"	307.00



Enclosed Indoor/Outdoor Cork Bulletin Board

These boards are made of self-sealing natural cork panels that provide an excellent, resilient tacking surface. Information will be secure and clearly visible behind shatter-proof acrylic doors. Indoor models have a satin finish anodized aluminum frame. Outdoor models feature an aluminum vented case with weather-resistant backing. Both styles have a lock and key for each door and full length hinges.

NUMBER	DESCRIPTION	SIZE	EACH	NUMBER	DESCRIPTION	SIZE	EACH
A50907-1009	Indoor, 1 Door	18" x 24"	\$232.52	A50928-0009	Outdoor, 1 Door	18" x 24"	\$279.05
A50907-1005	Indoor, 1 Door	24" x 36"	227.95	A50928-0015	Outdoor, 1 Door	24" x 36"	333.00
A50907-1007	Indoor, 2 Doors	48" x 36"	526.00	A50928-0042	Outdoor, 2 Doors	42" x 32"	487.00
A50907-1008	Indoor, 2 Doors	60" x 36"	547.00	A50928-0027	Outdoor, 2 Doors	48" x 36"	511.00
A50907-1042	Indoor, 2 Doors	42" x 32"	517.00	A50928-0060	Outdoor, 2 Doors	60" x 36"	619.00
A50907-1108	Indoor, 3 Doors	72" x 36"	788.00	A50928-0172	Outdoor, 3 Doors	72" x 36"	811.00
A50907-1109	Indoor, 3 Doors	72" x 48"	947.00	A50928-0072	Outdoor, 3 Doors	72" x 48"	934.00
A50907-1209	Indoor, 3 Doors	96" x 48"	1195.00	A50928-0096	Outdoor, 3 Doors	96" x 48"	1100.00



Satin Aluminum - 3 Door



Oak - 1 Door

Ghent® Enclosed Recycled Rubber Tackboards

Oak Frame			
NUMBER	DESCRIPTION	SIZE	EACH
A50981-8924	1 Door	36"H x 24"W x 2-1/4"D	\$270.51
A50981-8948	2 Door	36"H x 48"W x 2-1/4"D	316.00
A50981-8960	2 Door	36"H x 60"W x 2-1/4"D	362.00
A50981-8972	3 Door	36"H x 72"W x 2-1/4"D	738.00
Satin Aluminum Frame			
NUMBER	DESCRIPTION	SIZE	EACH
A50981-9324	1 Door	36"H x 24"W x 2-1/4"D	\$322.00
A50981-9348	2 Door	36"H x 48"W x 2-1/4"D	353.00
A50981-9360	2 Door	36"H x 60"W x 2-1/4"D	422.00
A50981-9372	3 Door	36"H x 72"W x 2-1/4"D	693.00

For more Ghent Tackboards, visit DickBlick.com.

OOK® ReadyNail Sawtooth Hangers
These sawtooth hangers feature a special collar that holds the nail in place for hands-free picture hanging. Available in two sizes, for hanging small or large artwork.

NUMBER	SIZE	EACH	12/EA
A18984-1010	Small, 3-pack	\$3.86	\$3.48
A18984-1020	Large, 3-pack	3.86	3.48

OOK® Picture Hook Kit
Includes 10 picture hooks for hanging 10–50 lb, two sawtooth hangers, 30 lb picture wire, 20 screw eyes, and 17 nails.

NUMBER	EACH	12/EA
A18988-1009	\$3.82	\$3.44



Ghent® Frameless Oval Bulletin Boards

Rich, durable fabrics in contemporary office colors. The fabric is laminated over sturdy, high-density fiberboard with a sealed backing that resists moisture absorption. Hangs vertically or horizontally. Custom made and non-returnable. •Requires truck shipment. FOB Factory. See page 648 for details.

SIZE	GRAY	BLUE	BEIGE	BLACK	EACH
24" x 18"	AF50922-2752	AF50922-5012	AF50922-8152	AF50922-2059	\$81.74
36" x 24"	AF50922-2753	AF50922-5013	AF50922-8153	AF50922-2055	110.45
•48" x 36"	AF50922-2754	AF50922-5014	AF50922-8154	AF50922-2057	171.44
•72" x 48"	AF50922-2756	AF50922-5016	AF50922-8156	AF50922-2058	383.00



A Blick® Large Print Rack

Constructed from stain-resistant, oiled beechwood, our generously sized print rack is ideal for displaying larger prints, drawings, and paintings. It measures 40-1/2"H x 31-1/2"W x 20-3/4"D.

NUMBER	EACH	6/EA
A46922-1001	\$158.62	\$142.76

B Blick® Small Print Rack

This lightweight rack is an attractive and affordable option for presenting or storing artwork. Constructed of stain-resistant oiled beechwood, it measures 30-3/4"H x 22"W x 14-1/4"D.

NUMBER	EACH	6/EA
A51333-1001	\$75.19	\$67.67

C Blick® Print Rack by Jullian®

Made exclusively for us by Jullian. Crafted of finished beechwood, it's sturdy, attractive, and folds quickly and easily for transport. Measures 33"H x 22"W with an open depth of 14". Holds up to 22 lb.

NUMBER	EACH	6/EA
A51343-1001	\$94.99	\$85.49

D Richeson® Ambrosia Print Rack

An attractive, hardwood showcase for studio, gallery, art fair — or take it anywhere. Durable and sturdy. Opens to hold numerous pieces of all sizes. Measures 32"H x 37"W x 22"D.

NUMBER	EACH	6/EA
A51319-0000	\$237.79	\$213.99

E Richeson® Steel Print Rack

Get unframed prints, posters, and paintings organized in no time flat! Richeson's heavy-duty black steel rack stores away lots of media in minimal space. And it's set on wheels, so it's a breeze to move from location to location. 32"H x 34"W x 18"D. Storage area is 22"W at top and tapers down to 6"W. Assembly required.

NUMBER	EACH	6/EA
A51328-2005	\$133.71	\$120.34

F Martin™ Universal Design Avanti® Metal Print Rack

This sturdy metal easel features a padded, rubber-lined bed with ridges to prevent artwork from sliding. Use it with the adjustable foot glides for stationary display, or add the multi-surface casters to make it mobile. Both are included in sets of four. Measures 29"H x 27-1/2"W x 21-1/2"D overall. Bed measures 25"W x 8-1/2"D. FOB Factory. See page 648 for details.

NUMBER	EACH	6/EA
AF51401-2500	\$189.38	\$170.43

G Richeson® Black Canvas Print Racks

Sturdy, attractive, lightweight, and portable, these print racks are great for presenting, organizing, and storing artwork. The medium and large racks are height-adjustable and have a 6" gusset. The small rack has a 4" gusset. For more dimension details, visit DickBlick.com.

NUMBER	DESCRIPTION	EACH	6/EA
A52505-1001	Small, 20"H x 18"W	\$84.46	\$75.99
A52505-1002	Medium, 37-3/4"H x 24"W	117.97	107.15
A52505-1003	Large, 38-1/2"H x 36"W	136.99	124.46



Screenflex® Light-Duty Divider

Turn one room into two! This divider is easy to set up again and again for quick, temporary classroom configurations — no assembly required. Constructed of sturdy steel framing, the dividers feature rigid, sound-absorbing panels that are fully tackable for visual presentations. They glide on ball bearing casters and can be set up in an angled or curved configuration. Made with woven designer fabric protected with Scotchgard.

3-Panel Divider, 5 ft 9" High

NUMBER	COLOR	EACH
A51140-8333	Desert	\$696.00
A51140-5253	Lake	696.00
A51140-5043	Navy	696.00
A51140-3013	Red	696.00
A51140-2673	Stone	696.00

5-Panel Divider, 9 ft 5" High

NUMBER	COLOR	EACH
A51140-8335	Desert	\$921.00
A51140-5255	Lake	921.00
A51140-5045	Navy	921.00
A51140-3015	Red	921.00
A51140-2675	Stone	921.00



3-Panel Display, 6 ft 5" High — Truck Shipment and FOB Factory. See page 648 for details.

NUMBER	COLOR	EACH
AF51136-2056	Black	\$540.00
AF51136-4866	Blue	540.00
AF51136-5916	Bright Blue	540.00
AF51136-2506	Gray	540.00
AF51136-7036	Green	540.00
AF51136-3546	Mauve	540.00
AF51136-1046	Oatmeal	540.00
AF51136-2986	Red	540.00
AF51136-8926	Wheat	540.00
AF51136-4026	Yellow	540.00

6-Panel Display, 5 ft 9" High — Truck Shipment and FOB Factory. See page 648 for details.

NUMBER	COLOR	EACH
AF51139-2055	Black	\$1026.00
AF51139-4865	Blue	1026.00
AF51139-5915	Bright Blue	1026.00
AF51139-2505	Gray	1026.00
AF51139-7035	Green	1026.00
AF51139-3715	Mauve	1026.00
AF51139-1015	Oatmeal	1026.00
AF51139-2985	Red	1026.00
AF51139-8925	Wheat	1026.00
AF51139-4025	Yellow	1026.00

6-Panel Display, 6 ft 5" High — FOB Factory. See page 648 for details.

NUMBER	COLOR	EACH
AF51139-2056	Black	\$1301.00
AF51139-4866	Blue	1301.00
AF51139-5916	Bright Blue	1301.00
AF51139-2506	Gray	1301.00
AF51139-7036	Green	1301.00
AF51139-3716	Mauve	1301.00
AF51139-1016	Oatmeal	1301.00
AF51139-2986	Red	1301.00
AF51139-8926	Wheat	1301.00
AF51139-4026	Yellow	1301.00

Black	Blue	Bright Blue	Green	Gray
Mauve	Oatmeal	Red	Wheat	Yellow

Screenflex® Mobile Displays

These three-panel and six-panel "star-shaped" mobile displays offer an abundance of display surface. They require no assembly and have self-leveling, locking caster wheels for instant stability. Just roll, extend, and lock into place! Durable fabric-covered panels are stain-resistant, making them ideal for displaying artwork, announcements, or instructional materials. Use in hallways, entryways, cafeterias, or any other high-traffic area where you want to make a statement. Frames are black powder-coated metal with full-length black painted metal hinges. Manufactured using 76% recycled materials. Truck Shipment and FOB Factory. See page 648 for details.

3-Panel Display, 5 ft 9" High

NUMBER	COLOR	EACH
AF51136-2055	Black	\$492.00
AF51136-4865	Blue	492.00
AF51136-5915	Bright Blue	492.00
AF51136-2505	Gray	492.00
AF51136-7035	Green	492.00
AF51136-3545	Mauve	492.00
AF51136-1045	Oatmeal	492.00
AF51136-2985	Red	492.00
AF51136-8925	Wheat	492.00
AF51136-4025	Yellow	492.00



Roll into position...

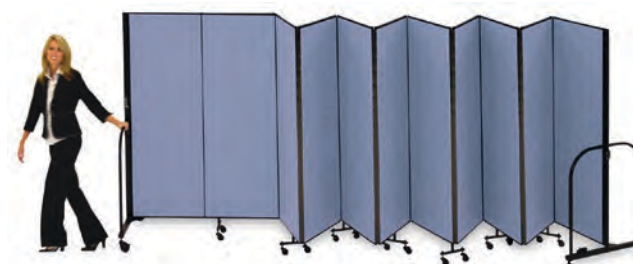

...expand...



...create any configuration you desire!



Screenflex® Multi-Unit Connectors

Attach dividers together end to end. The chrome-plated latches install on the end frames of your Portable Room Dividers. FOB Factory. See page 648 for details.

NUMBER	EACH
AF52293-1001	\$49.09



Blue	Bright Blue	Gray	
Red	Wheat	Yellow	Black



Tackable surface

Screenflex® Portable Room Dividers

6 ft High Dividers

Need to quickly divide a room or create an exhibit? Simply roll one or more of these versatile, portable dividers into position. They require no assembly and have self-leveling, locking casters for instant stability. Set them up straight, in a curved or angled configuration, or lock several together for unlimited possibilities. The durable fabric-covered panels are stain-resistant, sound-absorbent, and double as a teaching tool when used to display artwork or other instructional materials. Frame is black powder-coated metal with full-length black painted metal hinges. Manufactured using 76% recycled materials. A great solution when space is at a premium. Truck Shipment and FOB Factory. See page 648 for details.

6 ft High Dividers

NUMBER	COLOR	PANELS (LENGTH)	EACH
AF51123-4863	Blue	3 (5'9")	\$1034.00
AF51123-4865	Blue	5 (9'5")	1281.00
AF51123-4867	Blue	7 (13'1")	1546.00
A51123-5913	Bright Blue	3 (5'9")	1034.00
A51123-5915	Bright Blue	5 (9'5")	1281.00
A51123-5917	Bright Blue	7 (13'1")	1546.00
AF51123-2523	Gray	3 (5'9")	1034.00
AF51123-2525	Gray	5 (9'5")	1281.00
AF51123-2527	Gray	7 (13'1")	1546.00
A51123-2061	Gray	9 (16'9")	1831.00
A51123-2062	Gray	11 (20'5")	2185.00
A51123-2063	Gray	13 (24')	2469.00
A51123-2983	Red	3 (5'9")	1034.00
A51123-2985	Red	5 (9'5")	1281.00
A51123-2987	Red	7 (13'1")	1546.00
AF51123-4025	Wheat	5 (9'5")	1281.00
AF51123-4027	Wheat	7 (13'1")	1546.00
AF51123-4023	Wheat	3 (5'9")	1034.00
A51123-4127	Yellow	7 (13'1")	1546.00
A51123-4125	Yellow	5 (9'5")	1281.00
A51123-4123	Yellow	3 (5'9")	1034.00
AF51138-2065	Charcoal	3 (5'9")	999.00
AF51138-2069	Charcoal	5 (9'5")	1281.00
AF51138-2061	Charcoal	7 (13'1")	1517.00
A51138-2661	Charcoal	9 (16'9")	1969.00

8 ft High Dividers Truck Shipment and FOB Factory. See page 648 for details.

NUMBER	COLOR	PANELS (LENGTH)	EACH
AF51123-4868	Blue	7 (13'1")	\$2038.00
A51123-5918	Bright Blue	7 (13'1")	2038.00
AF51123-2528	Gray	7 (13'1")	2038.00
A51123-2081	Gray	9 (16'9")	2469.00
A51123-2082	Gray	11 (20'5")	2795.00
A51123-2083	Gray	13 (24')	3132.00
A51123-2988	Red	7 (13'1")	2038.00
AF51123-4028	Wheat	7 (13'1")	2038.00
A51123-4128	Yellow	7 (13'1")	2038.00
AF51138-2081	Charcoal	7 (13'1")	2018.00
A51138-2681	Charcoal	9 (16'9")	2548.00



Screenflex® Artwork Hanger

Display multiple pieces of framed art. Use the hangers with Screenflex portable partitions and dividers, or any vertical structure that measures 3/4" thick or less. The hanger measures 45" long, with small 1" wide hooks spaced 6" apart. Package of two.

NUMBER	EACH
A51142-1020	\$67.10

Did you know we have hundreds of lesson plans designed to meet the National Standards for Visual Arts Education? See them all at DickBlick.com/lesson-plans.



A Quartet® Show-It! Portable Display System

Lightweight, portable trifold display system adapts to any environment. Simply unfold, place on tabletop or floor, and your display is ready to go! Two-sided fabric panels are gray on one side and blue on the other. For use with latch-and-key fasteners, tacks, push-pins, or tape. Use the three-panel system by itself as a single tabletop display or the taller six-panel system as a floor display. When open, measures 84"W x 38"H (three-panel) or 84"W x 76"H (six-panel). Includes fabric carry bag. FOB Factory. See page 648 for details.

NUMBER	DESCRIPTION	EACH
AF51137-1003	3-Panel	\$519.00
AF51137-1006	6-Panel	938.00

B Claridge® Folding Screen

These durable folding screens are an economical, effortless way of creating flexible work areas. They are constructed with an anodized aluminum frame and double-action hinges. The tackable Nucork surface is on both sides of the screen and can be used as is or painted, papered, or covered with fabric. Screens fold nearly flat for easy storage and transport. FOB Factory. See page 648 for details.

NUMBER	SIZE	EACH
AF51134-2800	60"H x 72"W	\$902.00
AF51134-2810	68"H x 72"W	948.00
AF51134-2820	80"H x 72"W	1127.00

Flourish® Freestanding MeshPanel Display Walls

Display artwork quickly and easily with these moveable, freestanding display walls. Ideal for art fairs, classrooms, libraries, and exhibit halls, they are made of tough polyester mesh for quick and easy setup, breakdown, transport, and storage. Artwork can be displayed on both sides, and two-dimensional pieces can be hung using hook-clips (sold separately below). Tote your panels in the sturdy carrying bag (also sold separately). FOB Factory. See page 648 for details.

Steel Frame Display Wall

NUMBER	SIZE	EACH
AF51143-1004	7 ft x 4 ft	\$288.32
AF51143-1005	7 ft x 5 ft	294.68
AF51143-1010	7 ft x 10 ft	399.00

Steel Frame Display Wall on Wheels — FOB Factory. See page 648 for details.

NUMBER	SIZE	EACH
AF51143-4004	7 ft x 4 ft	\$315.00
AF51143-4005	7 ft x 5 ft	321.00
AF51143-4010	7 ft x 10 ft	426.00

Panel Accessories — For Freestanding and Zig Zag display walls. FOB Factory. See page 648 for details.

NUMBER	DESCRIPTION	EACH
AF51143-1065	Carry Bag for Steel Frame Models	\$65.71
AF51143-1087	Carry Bag for Aluminum Frame Models	65.71
AF51143-1012	Hook-Clips, Bag of 12	9.53
AF51143-1024	S-Hooks, Bag of 24	3.17

Flourish® Zig Zag MeshPanels Three-Panel Display Walls

Quick and easy to set up, these visually dynamic three-panel display walls support heavy pieces and feature six exhibit surfaces. They stand 7 ft high for easy, eye-level viewing of artwork. Choose steel or aluminum frames with either standard feet or wheels for extra convenience and mobility. Artwork can be hung using hook-clips or S-hooks (sold separately). Carry bag available (also sold separately). FOB Factory. See page 648 for details.

Aluminum Frame Zig Zag Wall

NUMBER	SIZE	EACH
AF51143-2004	Three 4 ft Panels	\$620.00
AF51143-2005	Three 5 ft Panels	636.00

Steel Frame Zig Zag Wall — FOB Factory. See page 648 for details.

NUMBER	SIZE	EACH
AF51143-3004	Three 4 ft Panels	\$636.00
AF51143-3005	Three 5 ft Panels	647.00

Steel Frame Zig Zag Wall on Wheels — FOB Factory. See page 648 for details.

NUMBER	SIZE	EACH
AF51143-2104	Three 4 ft Panels	\$660.00
AF51143-2105	Three 5 ft Panels	678.00

Panel Accessories — For Freestanding and Zig Zag display walls. FOB Factory. See page 648 for details.

NUMBER	DESCRIPTION	EACH
AF51143-1065	Carry Bag for Steel Frame Models	\$65.71
AF51143-1087	Carry Bag for Aluminum Frame Models	65.71
AF51143-1012	Hook-Clips, Bag of 12	9.53
AF51143-1024	S-Hooks, Bag of 24	3.17

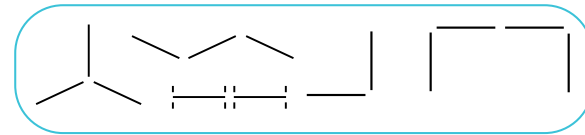

Multiplex® Display/Exhibit System

This modular system offers unlimited flexibility — set up a variety of configurations for display and exhibit purposes. Overall height of the panels is 78" with a 48" x 66" display area. The panel frame is 7/8" square steel tubing, welded together to form a sturdy, one-piece unit, finished with gray baked-on enamel. Each set of three panels includes black glides to protect floors and a set of straight, 90°, and 120° connecting brackets so that adjacent panels can be attached in a variety of angles. Or use free-standing panels with Display Panel Feet (sold separately). Choose from two functional surfaces. Truck Shipment and FOB Factory. See page 648 for details.

Gray Vinyl-Covered Surface — This durable, burlap-textured surface retains its rich appearance through years of hard use. It overlays 1/4" thick tackboard, the ideal display surface for lightweight items that can be attached with thumbtacks, push-pins, or staples. Great for unframed prints, posters, signs, and photos.

NUMBER	DESCRIPTION	EACH
AF51105-2503	Gray Vinyl, Set of 3 Panels	\$865.00
AF51105-2500	Gray Vinyl, Individual Panel	335.00



Multiplex® Swinging Panel Display

Space-saving units are a great way to display class pictures, athletics, and announcements. Choose floor or wall units with 10 or 20 two-sided panels. Gray metal frames have 0.04" thick sheets of clear plastic and white matboard backgrounds. Beige sold online. Truck Shipment and FOB Factory. See page 648 for details.

Floor Display Model

NUMBER	PANEL SIZE	PANELS	EACH
AF50914-2410	24" x 36"	10	\$1977.00
AF50914-2420	24" x 36"	20	3300.00
AF50914-2430	30" x 40"	10	2218.00
AF50914-2440	30" x 40"	20	3689.00

Wall-Mounted Model — Truck Shipment and FOB Factory. See page 648 for details.

NUMBER	PANEL SIZE	PANELS	EACH
AF50914-2450	24" x 36"	10	\$1715.00
AF50914-2460	24" x 36"	20	3005.00
AF50914-2470	30" x 40"	10	1898.00
AF50914-2480	30" x 40"	20	3429.00



Loop Fabric Surface — 100% nylon loop fabric is a highly attractive and versatile display panel surface. Simply attach Hook Tab Circles to the back of display items and press into position on the loop fabric surface. Your item is securely displayed yet can be easily removed and repositioned. Fabric is laminated to both sides of a 1/4" thick tackboard. Truck Shipment and FOB Factory. See page 648 for details.

NUMBER	DESCRIPTION	EACH
AF51105-5003	Blue Loop Fabric, Set of 3 Panels	\$1135.00
AF51105-2603	Silver Loop Fabric, Set of 3 Panels	1135.00
AF51105-5000	Blue Loop Fabric, Individual Panel	445.00
AF51105-2600	Silver Loop Fabric, Individual Panel	445.00
A51105-0000	5/8" Hook Tab Circles, Pack of 200	20.95

Display Panel Feet — T-shaped and finished to match the panels. Use one pair of feet per panel. Sold by the pair. FOB Factory. See page 648 for details.

NUMBER	EACH
AF51105-2700	\$94.99



Testrite® Exhibit Display Wall

A hassle-free way to set up an effective display. This stable unit has sturdy aluminum components, adjustable tilt, and vertical shelf positioning. Dismantled, the entire unit slides into a 7"H x 54"L zippered canvas carrying bag. It consists of a 68" high folding vertical stand and three shelves, two 52" long and one 36" long. Each shelf supports up to 50 lb and holds framed pieces up to 1-1/2" thick. Additional shelves are available in sets of two, as well as a 12" extension piece. Combined weight of 16-1/2 lb.

NUMBER	SIZE	EACH
A51122-1009	Bag Kit	\$231.29
A51122-1036	36" Shelves	43.92
A51122-1052	52" Shelves	63.19

12" Easel Extension — Locks on top of the display wall to accommodate larger canvases.

NUMBER	EACH	6/EA
A50207-1012	\$37.08	\$33.37



Midwest Products® Grip Pins
The perfect pin for every craft and hobby project! Featuring a longer, thinner shaft and a wide shoulder, these pins are more precise than straight pins, push pins, or T-pins. 50 pins in a convenient storage box. Grades 3-12.

NUMBER	EACH	6/EA5
A34956-1001	\$7.61	\$6.85



Invisible Ceiling Hooks
Just clip on the grid of a suspended ceiling and hang artwork, signs, mobiles, and more. Clear plastic, easy on and off. Package of two.

NUMBER	EACH	24/EA	48/EA
A57314-0009	\$2.17	\$1.95	\$1.85



Stikki Clips®
Strong white plastic clips with dependable "Stikki-Wax" back will cling to most surfaces. Just press wax side to mounting surface. Slide papers and posters in and out of plastic spring clip. Reusable. Package of 20.

NUMBER	EACH	12/EA
A57302-1009	\$4.88	\$4.36



Officemate® Push Pins
Hang important notes, reminders, memorable photos, documents, and much more with Officemate Push Pins. They're perfect for use on bulletin and cork boards.

NUMBER	DESCRIPTION	COLOR	EACH
A57372-1003	100 Pack	Clear	\$5.55
A57372-1001	200 pack	Clear	7.73
A57372-1002	100 Pack	Assorted Colors	5.55
A57372-1004	12 Pack, Giant	Assorted Colors	5.26



Officemate® Thumbtacks
These silver, precision-crafted tacks have a sharp 3/4" point that'll pin papers firmly in place. Each clamshell package includes 100 thumbtacks.

NUMBER	EACH	12/EA
A57371-9331	\$2.21	\$1.99



StikkiWorks® Ceiling Hangers
Easily hang light- to medium-weight objects from ceiling grids. Ceiling Hangers are designed to fit between standard suspended ceiling grids in offices and classrooms. They won't cause damage, and they can be reused. Each Grid Clip Kit is a complete hanger system, including one twist-on grid clip (with a 48" string attached) and one clothespin. The Put-Er Up-Er attaches and removes Grid Clips without standing on a ladder or stool.

NUMBER	DESCRIPTION	EACH	12/EA
A57374-1010	Grid Clip Kits, 10-Pack	\$10.91	\$9.82
A57374-1000	Put-Er Up-Er	5.71	5.14



Ghent® "Hold Up" Display Rail
A creative and safe solution for hanging artwork and memos — no tape, tacks, or push pins. Grips thick and thin items side by side. Papers slide in and out without tearing and a clear front lets the entire paper show through. Attaches with screws or double-sided tape.

NUMBER	LENGTH	EACH	12/EA
A57313-0048	4 ft	\$21.61	\$19.45
A57313-0060	5 ft	26.31	23.68
A57313-0072	6 ft	38.52	34.67
A57313-0096	8 ft	49.80	44.82

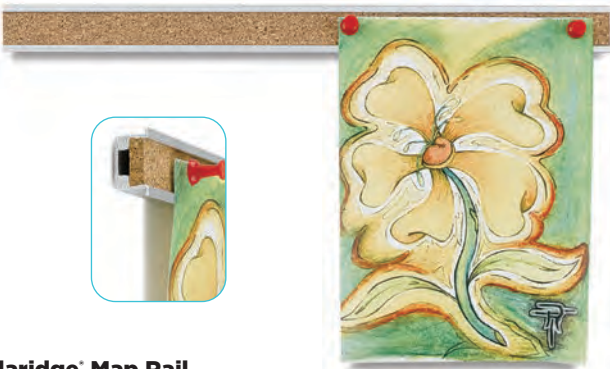

Claridge® Map Rail
Durable extruded aluminum map rail is approximately 1" wide with a 5/8" tan cork insert. Display materials using tacks or push pins. Rail is also designed to be used with map hooks, roller brackets, and flag holders. Installation is easy. With the recessed screw guide, no countersinking is necessary and no eyelets are required. The angled design helps keep the cork insert in place. FOB Factory. See page 648 for details.

Note: These items are custom-made and non-returnable.

NUMBER	LENGTH	EACH	4/EA
AF57329-1006	6 ft	\$30.38	\$27.34
AF57329-1008	8 ft	40.37	36.33



VELCRO® Brand Sticky Back™ Hook and Loop Fasteners
Easy-to-use fasteners for everyday jobs — just peel and stick. Ideal for smooth indoor surfaces. Holds up to 5 lb.

NUMBER	DESCRIPTION	COLOR	LENGTH	WIDTH	EACH	6/EA
A57319-2020	Pkg of 12 Squares	Black	7/8"	7/8"	\$3.40	\$3.06
A57319-1020	Pkg of 12 Squares	White	7/8"	7/8"	3.40	3.06
A57319-2010	Pkg of 15 Coins	Black	5/8"	5/8"	3.40	3.06
A57319-1010	Pkg of 15 Coins	White	5/8"	5/8"	3.40	3.06
A57319-2040	Tape Roll	Black	18"	3/4"	4.03	3.09
A57319-1040	Tape Roll	White	18"	3/4"	4.03	3.09
A57319-2011	Tape Roll	Black	15'	3/4"	23.13	20.82
A57319-1001	Tape Roll	Clear, Thin	15'	3/4"	23.13	20.82
A57319-1021	Tape Roll	White	15'	3/4"	23.13	20.82
A57319-2014	Tape Roll	Black	50'	3/4"	65.44	58.91
A57319-1024	Tape Roll	White	50'	3/4"	65.44	58.91

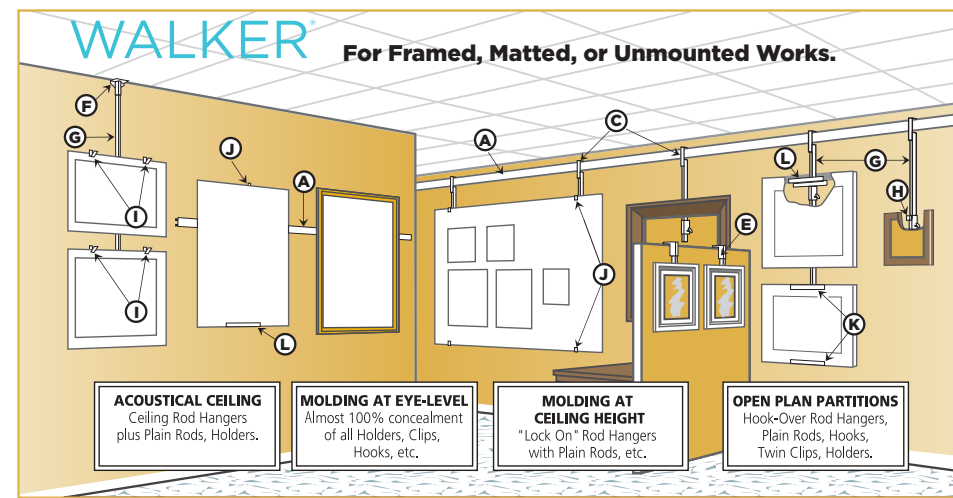

Step 1 — Hang your work on your walls, from the ceiling, or from your open plan partition. Use the Rod Sleeve and Molding that fit your wall area.

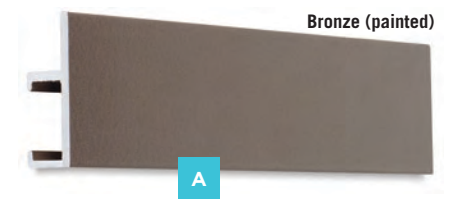

A Aluminum Molding — Offers a contemporary look with hidden fasteners. It measures 1" on the face and 3/8" from the wall. Select the unpainted molding and paint it yourself to match your color scheme. 8 ft length only. FOB Factory. See page 648 for details.

NUMBER	DESCRIPTION	EACH	12/EA
AF51106-1004	Aluminum (unpainted)	\$29.47	\$26.52
AF51106-1109	Gray (painted)	36.03	32.42
AF51106-1009	Bronze (painted)	36.03	32.42
AF51106-1102	White (painted)	36.03	32.42



B Lock-On Rod Sleeve — Secures a Plain Rod to molding. Easily attached and quickly adjusted for maximum flexibility in use. FOB Factory. See page 648 for details.

NUMBER	DESCRIPTION	EACH	24/EA
AF51104-8150	Bronze	\$6.60	\$5.94
AF51104-1200	White	6.60	5.94

C Ogee Rod Sleeves — Hook directly over wood molding. FOB Factory. See page 648 for details.

NUMBER	DESCRIPTION	EACH	24/EA
AF51104-2520	Gray	\$6.60	\$5.94
AF51104-8160	Bronze	6.60	5.94
AF51104-1040	White	6.60	5.94

D Hook-Over Rod Sleeve — For the top edge of open plan partitions. Order one Plain Rod for every sleeve. Silver. FOB Factory. See page 648 for details.

NUMBER	SIZE	EACH	24/EA
AF51104-1014	1/4"	\$6.60	\$5.94
AF51104-1012	1/2"	6.60	5.94
AF51104-1100	3/4"	6.60	5.94
AF51104-1001	1"	6.60	5.94
AF51104-1000	1-1/4"	6.60	5.94
AF51104-0015	1-1/2"	6.60	5.94
AF51104-1018	1-3/4"	6.60	5.94
AF51104-1002	2"	6.60	5.94

E Ceiling Rod Sleeve — Hangs from the wall angle of acoustical ceilings, holds a Plain Rod, Hooks, Holders, and Clips. White. FOB Factory. See page 648 for details.

NUMBER	EACH	24/EA
AF51104-1300	\$7.71	\$6.94

F Fiberglass Plain Rods FOB Factory. See page 648 for details.

NUMBER	COLOR	SIZE	EACH	24/EA
AF51103-8136	Bronze	36"	\$5.99	\$5.40
AF51103-8148	Bronze	48"	7.63	6.87
AF51103-8160	Bronze	60"	9.27	8.35
AF51103-8172	Bronze	72"	10.91	9.82
AF51103-2636	Lt. Gray	36"	5.99	5.40
AF51103-2648	Lt. Gray	48"	7.63	6.87
AF51103-2660	Lt. Gray	60"	9.27	8.35
AF51103-2672	Lt. Gray	72"	10.91	9.82
AF51103-1236	White	36"	5.99	5.40
AF51103-1248	White	48"	7.63	6.87
AF51103-1260	White	60"	9.27	8.35
AF51103-1272	White	72"	10.91	9.82

F Plated Steel Plain Rods — FOB Factory. See page 648 for details.

NUMBER	SIZE	EACH	24/EA
AF51103-1124	24"	\$7.63	\$6.87
AF51103-1136	36"	10.91	9.82
AF51103-1148	48"	13.09	11.78
AF51103-1160	60"	15.28	13.74
AF51103-1172	72"	17.46	15.72

F Clear Acrylic Plain Rods — Used for lightweight only. FOB Factory. See page 648 for details.

NUMBER	SIZE	EACH	24/EA
AF51103-1024	24"	\$4.36	\$3.92
AF51103-1036	36"	5.99	5.40
AF51103-1048	48"	7.63	6.87
AF51103-1060	60"	9.27	8.35
AF51103-1072	72"	10.91	9.82



Step 3 — The Hooks, Holders, and Clips slide on the Rods to hold all sizes and kinds of pictures or posters.



Hooks, Holders, and Clips — All of plated steel, slide onto Plain Rods and tighten the hardened thumb screws.

G Hi-Hook — Holds "saw-tooth" ring on plaques, certificates, etc. FOB Factory. See page 648 for details.

NUMBER	EACH	24/EA
AF51110-0100	\$6.54	\$5.89

H Twin Clip — Grips top edge of 3/16" thick work. FOB Factory. See page 648 for details.

NUMBER	EACH	24/EA
AF51110-0500	\$9.82	\$8.83

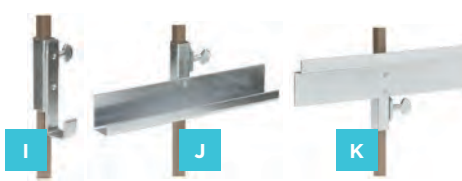

I Panel (and Mat) Holder — Use to hold top and bottom of panels and mats. FOB Factory. See page 648 for details.

NUMBER	DESCRIPTION	EACH	24/EA
AF51110-0025	For 1/4" thick panel	\$6.54	\$5.89
AF51110-1200	For 3/8" thick panel	6.54	5.89
AF51110-0053	For 1/2" thick panel	6.54	5.89
AF51110-1063	For 5/8" thick panel	6.54	5.89

J Long Holder — Holds outside of frames, top, and bottom. FOB Factory. See page 648 for details.

NUMBER	DESCRIPTION	EACH	24/EA
AF51110-1300	3/8" Frame	\$6.54	\$5.89
AF51110-0054	1/2" Frame	6.54	5.89
AF51110-1100	3/4" Frame	6.54	5.89
AF51110-1001	1" Frame	6.54	5.89

K Frame Hook — Holds frame with a "lip" or stretcher. FOB Factory. See page 648 for details.

NUMBER	DESCRIPTION	EACH	24/EA
AF51110-0400	Small (3/8" deep)	\$6.54	\$5.89
AF51110-0300	Large (7/8" deep)	6.54	5.89

Lifetime Warranty. Made in USA



Red with Satin Aluminum Frame



Royal Blue with Champagne Frame

Waddell Spirit Series Display Case

The Spirit Case combines the strength and durability of aluminum with the beauty of vivid school colors. The 12" high base is available in any one of 10 basic school colors. Sliding tempered glass doors are framed in anodized aluminum with a Satin Aluminum, Champagne, or Dark Bronze finish. Case includes four 14" deep adjustable half shelves with brackets, built-in locks, and levelers. Plaque fabric back. 72"H x 48"W x 16"D. Truck Shipment and FOB Factory. See page 648 for details.

COLOR	SATIN ALUMINUM FRAME	CHAMPAGNE FRAME	DARK BRONZE FRAME
Black	AF50830-1620	AF50830-1920	AF50830-8120
Forest Green	AF50830-1670	AF50830-1970	AF50830-8170
Goldenrod	AF50830-1600	AF50830-1900	AF50830-8100
Kelly Green	AF50830-1680	AF50830-1980	AF50830-8180
Maroon	AF50830-1640	AF50830-1940	AF50830-8140
Navy	AF50830-1650	AF50830-1950	AF50830-8150
Orange	AF50830-1610	AF50830-1910	AF50830-8110
Purple	AF50830-1690	AF50830-1990	AF50830-8190
Red	AF50830-1630	AF50830-1930	AF50830-8130
Royal Blue	AF50830-1660	AF50830-1960	AF50830-8160
	EACH \$2955.00	EACH \$2955.00	EACH \$2955.00



Natural Oak with Mirror Back

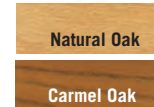

White Back with Unit Cornice

WADDELL



Natural Oak with Satin Frame

Base Colors

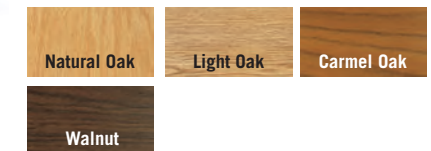

Frame Colors

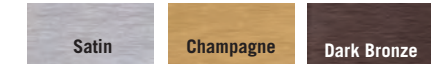

Waddell Keepsake Series Display Cases

Aluminum-framed cases feature three adjustable shelves, a locking hinged door, tempered glass, and built-in floor levelers. Natural Oak and Carmel Oak bases are wood veneer; Walnut and Light Oak bases are wood-grained vinyl. 72"H x 24"W x 24"D. Truck Shipment and FOB Factory. See page 648 for details.

Mirror Back

NUMBER	WOOD BASE	FRAME	EACH
AF50825-8310	Carmel Oak	Champagne	\$2364.00
AF50825-2610	Light Oak	Champagne	2364.00
AF50825-8510	Natural Oak	Champagne	2364.00
AF50825-8910	Walnut	Champagne	2364.00
AF50825-8320	Carmel Oak	Dark Bronze	2364.00
AF50825-2620	Light Oak	Dark Bronze	2364.00
AF50825-8520	Natural Oak	Dark Bronze	2364.00
AF50825-8920	Walnut	Dark Bronze	2364.00
AF50825-8300	Carmel Oak	Satin	2364.00
AF50825-2600	Light Oak	Satin	2364.00
AF50825-8500	Natural Oak	Satin	2364.00
AF50825-8900	Walnut	Satin	2364.00

Clear Back Truck Shipment and FOB Factory. See page 648 for details.

NUMBER	WOOD BASE	FRAME	EACH
AF50825-8340	Carmel Oak	Champagne	\$2364.00
AF50825-8540	Natural Oak	Champagne	2364.00
AF50825-2640	Light Oak	Champagne	2364.00
AF50825-8940	Walnut	Champagne	2364.00
AF50825-8350	Carmel Oak	Dark Bronze	2364.00
AF50825-2650	Light Oak	Dark Bronze	2364.00
AF50825-8550	Natural Oak	Dark Bronze	2364.00
AF50825-8950	Walnut	Dark Bronze	2364.00
AF50825-8330	Carmel Oak	Satin	2364.00
AF50825-2630	Light Oak	Satin	2364.00
AF50825-8530	Natural Oak	Satin	2364.00
AF50825-8930	Walnut	Satin	2364.00

Waddell Heritage Series Solid Oak Frame Floor Case

The rich oak tones of this case attractively set off items displayed in the case. Features open-dovetail tenon joints on solid wood corners. Black scuff-resistant base is offset for ample toe room. Tempered safety glass on all exposed surfaces, sliding doors with built-in locks and four shelves, each 14" deep, half-length, double-strength glass with brackets. Mirror Back cases are backed with ANSI safety tape. Plaque Back is an off-white nylon loop fabric which may be used with hook and loop fasteners. Tempered pattern glass on top diffuses cornice light to show your treasures to their greatest advantage. 70"H x 48"W x 18"D (76"H with cornice light fixture). Truck Shipment and FOB Factory. See page 648 for details.

White Back Cases

NUMBER	DESCRIPTION	EACH
AF50813-0600	Carmel Oak Finish	\$2052.00
AF50813-1000	Carmel Oak with Cornice	2897.00
AF50813-0300	Natural Oak Finish	2052.00
AF50813-0000	Natural Oak with Cornice	2897.00

Mirror Back Cases — Truck Shipment and FOB Factory. See page 648 for details.

NUMBER	DESCRIPTION	EACH
AF50813-0400	Carmel Oak Finish	\$2052.00
AF50813-0800	Carmel Oak with Cornice	2897.00
AF50813-0100	Natural Oak Finish	2052.00
AF50813-1100	Natural Oak with Cornice	2897.00

Plaque Back Cases — Truck Shipment and FOB Factory. See page 648 for details.

NUMBER	DESCRIPTION	EACH
AF50813-0500	Carmel Oak Finish	\$2052.00
AF50813-0900	Carmel Oak with Cornice	2897.00
AF50813-0200	Natural Oak Finish	2052.00
AF50813-0700	Natural Oak with Cornice	2897.00

Did you know we have hundreds of lesson plans designed to meet the National Standards for Visual Arts Education? See them all at DickBlick.com/lesson-plans.

Xylem™ Portable Pro Pedestals

Economical, attractive, and easy to assemble and transport, these pedestals feature a 1/8" thick MDF body, clad with a coat of black textured satin vinyl. 11-1/4"W x 11-1/4"D. Self-stabilizing ballast system. Can support 75 lb. Made in the USA. FOB Factory. See page 648 for details.

NUMBER	SIZE	EACH
AF50827-2030	30"H	\$116.80
AF50827-2036	36"H	122.50
AF50827-2042	42"H	128.19

42"H x 50"W x 4"D, with 5" Header



42"H x 50"W x 4"D

Waddell Legacy Series Wall-Mounted Display Cabinet

A distinguished way to display plaques, ribbons, citations, awards, and announcements. This solid oak case with lockable, tempered glass sliding doors is ideal for high traffic areas because it extends only four inches from the wall. Hanging hardware is included. Finished in Natural Oak with Champagne anodized aluminum trim. FOB Factory. See page 648 for details.

Cork Back

NUMBER	SIZE	EACH
AF50831-1010	42"H x 50"W x 4"D, with 5" Header	\$2031.00
AF50831-1148	48"H x 36"W x 4"D	1147.00
AF50831-1160	60"H x 36"W x 4"D	1369.00
AF50831-1172	72"H x 36"W x 4"D	1571.00
AF50831-1248	48"H x 48"W x 4"D	1320.00
AF50831-1260	60"H x 48"W x 4"D	1523.00
AF50831-1272	72"H x 48"W x 4"D	1866.00

Plaque Back — FOB Factory. See page 648 for details.

NUMBER	SIZE	EACH
AF50831-1020	42"H x 50"W x 4"D, with 5" Header	\$1887.00
AF50831-1348	48"H x 36"W x 4"D	984.00
AF50831-1360	60"H x 36"W x 4"D	1126.00
AF50831-1372	72"H x 36"W x 4"D	1273.00
AF50831-1448	48"H x 48"W x 4"D	1132.00
AF50831-1460	60"H x 48"W x 4"D	1290.00
AF50831-1472	72"H x 48"W x 4"D	1643.00

Waddell Colossus Series Display Cases

Ample room for large displays. Aluminum framing with a built-in lock secures the sliding tempered glass doors. Premium features include eight half-length adjustable shelves, steel shelving hardware, built-in floor levelers, and a black accent base. Truck Shipment and FOB Factory. See page 648 for details.

White Back — 66"H x 60"W x 20"D.

NUMBER	COLOR	EACH
AF50824-2206	Satin Aluminum	\$4749.00
AF50824-9016	Champagne Aluminum	4749.00
AF50824-8156	Dark Bronze	4749.00

Plaque Back — 66"H x 60"W x 20"D. Truck Shipment and FOB Factory. See page 648 for details.

NUMBER	COLOR	EACH
AF50824-2216	Satin Aluminum	\$4749.00
AF50824-9026	Champagne Aluminum	4749.00
AF50824-8166	Dark Bronze	4749.00

White Back — 66"H x 72"W x 20"D. Truck Shipment and FOB Factory. See page 648 for details.

NUMBER	COLOR	EACH
AF50824-2207	Satin Aluminum	\$5094.00
AF50824-9017	Champagne Aluminum	5094.00
AF50824-8157	Dark Bronze	5094.00

Plaque Back — 66"H x 72"W x 20"D. Truck Shipment and FOB Factory. See page 648 for details.

NUMBER	COLOR	EACH
AF50824-2217	Satin Aluminum	\$5094.00
AF50824-9027	Champagne Aluminum	5094.00
AF50824-8167	Dark Bronze	5094.00



Side View



Diversified Woodcrafts™ Mobile Storage Cabinet

This unit has three lockable drawers and one cabinet with a lockable door and an adjustable shelf. Constructed of solid maple and maple veneers, it features a pegboard and nine hooks on the outside of the cabinet. Durable, chemical-resistant, non-emitting UV finish. 4" locking swivel casters. 36-1/2"H x 36"W x 24"D overall.

NUMBER	DESCRIPTION	EACH
A52341-1002	ChemGuard Top	\$1206.00
A52341-1001	Maple Top	1290.00



Hann™ Hardwood Storage Cabinet

This cabinet provides five fixed center shelves approximately 28"W x 19"D for the 30" model and 46"W x 19"D for the 48" model. Shipped assembled. Cabinets are 84"H x 22"D. Truck Shipment and FOB Factory. See page 648 for details.

NUMBER	WIDTH	SHIPPING WEIGHT	EACH
AF51215-1032	30"	300 lb	\$1210.00
AF51215-1048	48"	410 lb	1409.00



Hann™ Tote Tray Storage Cabinet

This cabinet provides great flexibility for the art department. Made of hard maple framing and hardwood panels. Two large cupboard doors are fitted with heavy-duty hinges and cylinder lock. Cabinet comes complete with 24 or 48 plastic trays, each 12-1/2" x 18" x 3-1/2". Overall cabinet size is 84"H x 48"W x 22"D. Ships assembled. Shipping weight is approximately 485 lb. FOB Factory. See page 648 for details.

NUMBER	TRAYS	EACH
AF51218-1001	24	\$2138.00
AF51218-1006	48	3065.00



Debcor™ All-Purpose Tote Trays

Versatile, all-purpose trays for work or storage. Made of sturdy, high-impact, practically unbreakable material. Lightweight and easy to handle. Smooth surface provides for easy cleaning. Resists inorganic chemicals. Trays can nest. Tan color. Aluminum card holder on all trays. Note: Sizes stated may vary 1/16" more or less. FOB Factory. See page 648 for details.

NUMBER	MODEL	LENGTH	WIDTH	DEPTH	LIP	EACH
AF51202-1001	DEB 1	13"	10-1/2"	2"	1/2"	\$18.68
AF51202-1002	DEB 2	13-1/8"	10-1/2"	4-3/8"	1/2"	21.15
AF51202-1004	DEB 4	14"	12"	4"	1/2"	21.94
AF51202-1006	DEB 6	16"	12"	4"	1/2"	22.77
AF51202-1007	DEB 7	16-5/8"	13-1/8"	3-1/2"	1/2"	22.18
AF51202-1011	DEB 11	19"	9"	4-3/8"	1/2"	21.70
AF51202-1013	DEB 13	19"	12-1/2"	4-3/8"	1/2"	25.34
AF51202-1014	DEB 14	19"	13-3/4"	3-1/2"	1/2"	22.99
AF51202-1015	DEB 15	19"	13-3/4"	4-3/8"	1/2"	23.91

Safco® Boltless Shelving Units

Bring versatility to your classroom or art room with these sturdy steel shelving units. Available in two widths, the units assemble in minutes without tools, nuts, or bolts as either a five-shelf, 72"H storage unit or as a 36"H workbench. Black powder-coated finish. FOB Factory. See page 648 for details.

NUMBER	SIZE	EACH
AF50829-2036	36"W x 18"D	\$261.29
AF50829-2048	48"W x 18"D	266.84



A Sandusky Lee® Storage Cabinets

Sturdy, functional, and secure with all-metal construction with an enamel finish. Double doors feature a three-point locking mechanism. The four heavy-gauge steel shelves are adjustable on 2" centers. Truck Shipment and FOB Factory. See page 648 for details.

42"H x 36"W — Truck Shipment and FOB Factory. See page 648 for details.

NUMBER	COLOR	DEPTH	SHIPPING WEIGHT	EACH
AF51290-2042	Black	18"	77 lb	\$629.00
AF51290-4042	Blue	18"	77 lb	629.00
AF51290-2642	Dove Gray	18"	77 lb	629.00
AF51290-8042	Putty	18"	77 lb	629.00
AF51290-8542	Tropic Sand	18"	77 lb	629.00

72"H x 36"W — Truck Shipment and FOB Factory. See page 648 for details.

NUMBER	COLOR	DEPTH	SHIPPING WEIGHT	EACH
AF51290-2072	Black	18"	114 lb	\$745.00
AF51290-4072	Blue	18"	114 lb	745.00
AF51290-2672	Dove Gray	18"	114 lb	745.00
AF51290-8072	Putty	18"	114 lb	745.00
AF51290-8572	Tropic Sand	18"	114 lb	745.00
AF51290-2472	Black	24"	126 lb	869.00
AF51290-4172	Blue	24"	126 lb	869.00
AF51290-2772	Dove Gray	24"	126 lb	869.00
AF51290-8472	Putty	24"	126 lb	869.00
AF51290-8672	Tropic Sand	24"	126 lb	869.00

78"H x 36"W — Truck Shipment and FOB Factory. See page 648 for details.

NUMBER	COLOR	DEPTH	SHIPPING WEIGHT	EACH
AF51290-2078	Black	18"	120 lb	\$837.00
AF51290-4078	Blue	18"	120 lb	837.00
AF51290-2678	Dove Gray	18"	120 lb	837.00
AF51290-8078	Putty	18"	120 lb	837.00
AF51290-8578	Tropic Sand	18"	120 lb	837.00
AF51290-2478	Black	24"	137 lb	938.00
AF51290-4178	Blue	24"	137 lb	938.00
AF51290-2778	Dove Gray	24"	137 lb	938.00
AF51290-8478	Putty	24"	137 lb	938.00
AF51290-8678	Tropic Sand	24"	137 lb	938.00

Extra Shelves 1"H x 36"W — Truck Shipment and FOB Factory. See page 648 for details.

NUMBER	COLOR	DEPTH	SHIPPING WEIGHT	EACH
AF51290-2018	Black	18"	14 lb	\$53.99
AF51290-4018	Blue	18"	14 lb	53.99
AF51290-2618	Dove Gray	18"	14 lb	53.99
AF51290-8018	Putty	18"	14 lb	53.99
AF51290-8518	Tropic Sand	18"	14 lb	53.99
AF51290-2024	Black	24"	19 lb	63.99
AF51290-4024	Blue	24"	19 lb	63.99
AF51290-2624	Dove Gray	24"	19 lb	63.99
AF51290-8024	Putty	24"	19 lb	63.99
AF51290-8524	Tropic Sand	24"	19 lb	63.99

B Sandusky Lee® Mobile General Storage Cabinets & Carts

These spacious, easy-to-move, industrial-grade storage units are sturdy enough to withstand daily use. Move the adjustable shelves in 2" increments to suit your storage needs. Cabinets sit on a heavy-duty base with four 5" casters (two locking). For a smaller Storage Cart, visit DickBlick.com. FOB Factory. See page 648 for details.

Cabinets

NUMBER	COLOR	SIZE	EACH
AF51216-2055	Black	66"H x 36"W	\$1081.00
AF51216-2027	Black	78"H x 36"W	1326.00
AF51216-4865	Blue	66"H x 36"W	1081.00
AF51216-5017	Blue	78"H x 36"W	1326.00
AF51216-2515	Dove Gray	66"H x 36"W	1081.00
AF51216-2617	Dove Gray	78"H x 36"W	1326.00
AF51216-2597	Dove Gray	66"H x 46"W	1251.00
AF51216-8495	Putty	66"H x 36"W	1081.00
AF51216-8496	Putty	78"H x 36"W	1326.00
AF51216-8497	Putty	66"H x 46"W	1251.00
AF51216-8506	Tropic Sand	66"H x 36"W	1081.00
AF51216-8507	Tropic Sand	78"H x 36"W	1326.00

Carts

NUMBER	COLOR	SIZE	EACH
A51216-2026	Black	36"H x 36"W	\$735.00
A51216-2028	Black	48"H x 36"W	779.00
A51216-2024	Black	48"H x 46"W	916.00
A51216-5016	Blue	36"H x 36"W	735.00
A51216-5018	Blue	48"H x 36"W	779.00
A51216-5014	Blue	48"H x 46"W	916.00
A51216-3006	Dove Gray	36"H x 36"W	735.00
A51216-3008	Dove Gray	36"H x 46"W	779.00
A51216-2614	Dove Gray	48"H x 46"W	916.00
A51216-8499	Putty	36"H x 36"W	735.00
A51216-8498	Putty	36"H x 46"W	779.00
A51216-8494	Putty	48"H x 46"W	916.00
A51216-8505	Tropic Sand	36"H x 36"W	735.00
A51216-8508	Tropic Sand	48"H x 36"W	779.00
A51216-8504	Tropic Sand	48"H x 46"W	916.00



A

B

72"H x 36"W

78"H x 36"W

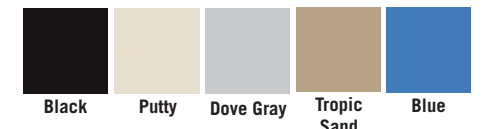

Black

Putty

Dove Gray

Tropic Sand

Blue



Smith System™ Cascade Mega-Tower Tote Tray Storage Unit

Part of a comprehensive organization, storage, and distribution solution for classroom materials and learning aids, these units contain bins for holding a wide variety of supplies. Each unit stands 60-1/2" tall and features welded 18-gauge steel construction, protected with a durable powder-coated surface. Totes are made of durable, recyclable clear ABS plastic. Casters included.

Mega-Tower — The open design of this unit allows Tote contents to be viewed easily. The unit measures 60-1/2"H x 42-5/8"W x 19"D and includes 24, 3" EW Totes.

NUMBER	EACH
A51296-9124	\$2248.00

Mega-Tower with Door — This unit features a door for securing its contents. It measures 60-1/2"H x 42-5/8"W x 19"D and includes 24, 3" EW Totes.

NUMBER	EACH
A51296-9224	\$2579.00



Hann™ Portfolio Storage Cabinet

Keep artwork and portfolios organized and out of the way. This adjustable, heavy-duty storage center features removable dividers so you can accommodate thicker items as needed. Default spacing creates 13 separate storage slots, each measuring 24-3/4"H x 2-1/4"W x 29"D. The dividers are 1/4" thick and made of hardboard. Top is smooth, 3/4" thick Fibersin. Measures 33"H x 39"W x 30"D. Made in the USA from solid hard maple. FOB Factory. See page 648 for details.

NUMBER	EACH
AF52317-1030	\$708.00



Diversified Woodcrafts Portfolio and Canvas Storage Cabinet

The perfect place to store works in progress. Sturdily built with solid maple and maple veneers, this cabinet can hold as many as 39 portfolios up to 24" x 30". It's also great for storing wet canvas while it dries. The zinc dividers are removable to accommodate thicker items. Measures 84"H x 36"W x 30"D. Made in the USA. FOB Factory. See page 648 for details.

NUMBER	EACH
AF52322-2084	\$1655.00

Steel Art Files

Low-cost filing and storage for bulky mechanicals, large layouts, and original art. Each file measures 27-3/4"H x 36"W x 20"D and consists of a sturdy steel shell with six dividers that may be moved to create compartments of desired width. Each compartment may then be coded or keyed for easy identification of contents. Units may be used singly, alongside each other, or stacked. Constructed of heavy-gauge prime steel with gray enamel finish. Extremely rigid — will not warp, twist, or sag. FOB Factory. See page 648 for details.



NUMBER	EACH	3/EA
AF51224-0000	\$463.00	\$417.00



Saftco™ Art Rack

The Art Rack vertically stores and protects oversized layouts, original art, mechanicals, and keylines. Upright materials resist warping and are easier to find than stacked or shelved materials. Channels for labeling, top and bottom, allow you to identify contents. Constructed of a strong wood-core product, the brawny racks easily hold hundreds of pounds. Putty-colored textured vinyl laminate finish. Tempered hardwood dividers create eight, 4-1/4" wide compartments. Racks can be stacked vertically or used side-by-side. Overall size: 29"H x 36"W x 24-1/4"D. Assembly required. (One unit shown.) Truck Shipment and FOB Factory. See page 648 for details.

NUMBER	EACH	3/EA
AF51205-1003	\$450.00	\$425.00



Saftco™ Giant Stacking Trays

Create durable and efficient flat filing at a fraction of the cost of other products. Trays can be stacked up to 5 ft high and have a hefty, 40 lb per tray load capacity. Big, 2"H x 42-1/2"W x 32-1/2"D (inside dimensions) trays accommodate most prints, drawings, papers, and more. Materials are always accessible. Made of heavy-duty, steel-reinforced polyethylene to last for years to come. May be used alone or with existing filing systems for extra storage space. Carton of two trays. FOB Factory. See page 648 for details.

NUMBER	EACH	6/EA
AF51209-1009	\$302.00	\$274.99

Small Stacking Trays — A smaller version of the same trays above. 3"H x 39"W x 26"D. Inside dimensions: 2"H x 36-1/2"W x 24-1/4"D. Carton of two trays. FOB Factory. See page 648 for details.

NUMBER	EACH	6/EA
AF51209-1109	\$262.99	\$239.99



Oklahoma Sound™ Charging Storage Carts

Charge and store tablets and laptops in one convenient cart. Two recessed power strips charge half or all of your class's tablets and laptops. Slotted storage offers safe and healthy ventilation. The carts provide quick and easy access to tablets and laptops, and the doors can be locked for extra protection. High-pressure thermofused laminate finish. Four heavy-duty casters included.

NUMBER	SIZE	CAPACITY	EACH
A54996-2413	43-1/4" x 19-1/4 x 37"	24 Laptops	\$1361.00
A54996-2411	43-1/4" x 20" x 24"	24 Tablets	978.00
A54996-2412	36-1/4" x 23-1/4" x 18-1/4"	32 Tablets	927.00



Smith System™ Everything Cart

This durable welded steel cart is designed to hold books, supplies, student work, storage bins, and more. It moves easily on quiet, 4" dual-wheel casters. Used in place of costly fixed storage areas, class projects can be rolled to the work area. The Everything Cart features two bins, each divided into six pockets measuring 6" high x 11" wide x 8" deep. End panels and shelves are welded and feature a baked-on finish and no sharp edges. The overall dimensions are 36" high x 36" wide x 18" deep.

NUMBER	COLOR	EACH
A51282-2050	Black	\$395.00
A51282-1100	Clementine	395.00
A51282-7270	Forest Green	395.00
A51282-5070	Navy	395.00
A51282-9380	Platinum	395.00
A51282-5630	Purple	395.00
A51282-2980	Red	395.00
A51282-8530	Sand	395.00

Luxor™ Mobile Cart

This compact, adjustable utility cart features blow-molded plastic shelves with metal frames and heavy-duty 3" casters, two with locking brakes. The adjustable shelves measure 15½" x 22". Assembly is required. Weighs 23 lb.

NUMBER	EACH
A52011-1010	\$179.98



Gratnells™ Callero Plus Tilted Tray Cart

Mobile modular storage with a touch of style. Perfect for classrooms, art studios, and playrooms, this cart can be used as a standalone unit or in combination with other carts. It has a crossbar and tilted trays for easy viewing and access. It includes feet and braked casters.

NUMBER	COLOR	EACH
A52334-3570	Flame Red	\$750.00
A52334-7240	Grass Green	750.00
A52334-5050	Royal Blue	750.00
A52334-4910	Sunshine Yellow	750.00
A52334-1730	Translucent	750.00



Gratnells™ Rover All Terrain Mobile Cart

The Rover cart is tough and practical, so you can move heavy loads around with ease — even up and down stairs. It has 260 mm pneumatic tires for all types of terrain and a metal frame for durability. It includes five sets of runners for a variety of tray combinations, and a strap secures the trays and contents. For more tray options, visit DickBlick.com.

2 Jumbo F3 Trays

NUMBER	COLOR	EACH
A52335-3572	Flame Red	\$499.00
A52335-7242	Grass Green	499.00
A52335-5052	Royal Blue	499.00
A52335-4912	Sunshine Yellow	499.00
A52335-2502	Translucent Gray	499.00

3 Deep F2 Trays

NUMBER	COLOR	EACH
A52335-3570	Flame Red	\$499.00
A52335-7240	Grass Green	499.00
A52335-5050	Royal Blue	499.00
A52335-4910	Sunshine Yellow	499.00
A52335-2500	Translucent Gray	499.00

3 Extra Deep F25 Trays

NUMBER	COLOR	EACH
A52335-3571	Flame Red	\$499.00
A52335-7241	Grass Green	499.00
A52335-5051	Royal Blue	499.00
A52335-4911	Sunshine Yellow	499.00
A52335-2501	Translucent Gray	499.00



Bieffe 10 Drawer Filing Cabinet

Constructed of durable sheet metal, the cabinet has a scratch-resistant black epoxy finish and a safety lock that protects valuable documents. Both the top and base are included as an add-on option. Four locking casters. 38"H x 21-1/4"W x 15-1/2"D.

NUMBER	EACH
A52326-2021	\$1129.00



Hann Mobile Paper Storage Cart

This sharp cabinet has five large drawers, ideal for storing paper and supplies in the classroom and studio. It features maple framing and birch paneling with a natural finish. A fibersin top provides a hard, smooth work surface. Lockable, heavy-duty casters. Drawers measure 2-3/4"H x 41"W x 24"D. The cabinet measures 35"H x 48"W x 28"D.

NUMBER	EACH
A52315-1010	\$1869.00



HIGH SMALL BASE



BASE



Safco Facil Flat Files

This version of the popular Safco flat file is an economical solution for all non-archival storage needs. Constructed of steel with a light gray powder-coated finish, these flat files are stackable two high on a Closed Small or Medium Base, or one high on a High Base. The non-locking drawers have a 60 lb capacity. Closed Small Bases and Closed Medium Bases have a 2" recess for toe space. High Bases raise a single file to a convenient work height. Assembly required. Truck Shipment and FOB Factory. See page 648 for details.

FILES	NUMBER	SIZE	EACH
	AF51276-1010	Small, 16-1/2"H x 40-1/4"W x 26"D	\$1041.00
	AF51276-1020	Medium, 16-1/2"H x 40-1/4"W x 32"D	1278.00
Bases — Truck Shipment and FOB Factory. See page 648 for details.			
FILES	NUMBER	SIZE	EACH
	AF51276-1011	Closed Small, 4-3/4"H x 40-1/4"W x 24"D	\$164.20
	AF51276-1021	Closed Medium, 4-3/4"H x 46-1/4"W x 30"D	213.18
	AF51276-1030	High Small, 20-1/2"H x 40-1/4"W x 25-3/4"D	386.00
	AF51276-1041	High Medium, 20-3/4"H x 46-1/4"W x 31-3/4"D	430.00

Safco 5-Drawer Steel Flat Files

A classic in flat materials storage! These handsome units are self-contained with welded steel construction, wrap-around corners, and a sturdy inner frame. Each 2-1/8" high drawer has ball-bearing side rollers, a stationary back hook, and a piano-hinged front depressor. Use them by themselves on a base or table, line them up to create a bank of files, or stack them securely without bolts or brackets using the included anti-slip pads. Durable, powder-coated finish. Optional 6" high enclosed bases (sold separately) are available in coordinating colors. Truck Shipment and FOB Factory. See page 648 for details.

5-Drawer Steel Flat Files	NUMBER	COLOR	DRAWER SIZE	FLAT FILE SIZE	WEIGHS	EACH
	AF51206-1025	Black	37" x 26" x 2-1/8"	16-1/2" x 40-3/8" x 29-3/8"	177 lb	\$1319.00
	AF51206-1026	Black	43" x 32" x 2-1/8"	16-1/2" x 46-3/8" x 35-3/8"	222 lb	1520.00
	AF51206-1028	Black	50" x 38" x 2-1/8"	16-1/2" x 53-3/8" x 41-3/8"	267 lb	1802.00
	AF51206-2775	Gray	37" x 26" x 2-1/8"	16-1/2" x 40-3/8" x 29-3/8"	177 lb	1319.00
	AF51206-2776	Gray	43" x 32" x 2-1/8"	16-1/2" x 46-3/8" x 35-3/8"	222 lb	1520.00
	AF51206-2778	Gray	50" x 38" x 2-1/8"	16-1/2" x 53-3/8" x 41-3/8"	267 lb	1802.00
	AF51206-8525	Tropical Sand	37" x 26" x 2-1/8"	16-1/2" x 40-3/8" x 29-3/8"	177 lb	1319.00
	AF51206-8526	Tropical Sand	43" x 32" x 2-1/8"	16-1/2" x 46-3/8" x 35-3/8"	222 lb	1520.00
	AF51206-8528	Tropical Sand	50" x 38" x 2-1/8"	16-1/2" x 53-3/8" x 41-3/8"	267 lb	1802.00
	AF51206-1155	White	37" x 26" x 2-1/8"	16-1/2" x 40-3/8" x 29-3/8"	177 lb	1319.00
	AF51206-1156	White	43" x 32" x 2-1/8"	16-1/2" x 46-3/8" x 35-3/8"	222 lb	1520.00
	AF51206-1158	White	50" x 38" x 2-1/8"	16-1/2" x 53-3/8" x 41-3/8"	267 lb	1802.00

Optional Bases — Truck Shipment and FOB Factory. See page 648 for details.	NUMBER	COLOR	BASE DIMENSIONS	FOR FILE ABOVE	WEIGHS	EACH
	AF51206-1005	Black	40-3/8" x 26-5/8" x 6"	51206-1025	24 lb	\$295.00
	AF51206-1006	Black	46-3/8" x 32-5/8" x 6"	51206-1026	28 lb	300.00
	AF51206-1008	Black	53-3/8" x 38-5/8" x 6"	51206-1028	32 lb	379.00
	AF51206-2755	Gray	40-3/8" x 26-5/8" x 6"	51206-2775	24 lb	295.00
	AF51206-2756	Gray	46-3/8" x 32-5/8" x 6"	51206-2776	28 lb	300.00
	AF51206-2758	Gray	53-3/8" x 38-5/8" x 6"	51206-2778	32 lb	379.00
	AF51206-8505	Tropical Sand	40-3/8" x 26-5/8" x 6"	51206-8525	24 lb	295.00
	AF51206-8506	Tropical Sand	46-3/8" x 32-5/8" x 6"	51206-8526	28 lb	300.00
	AF51206-8508	Tropical Sand	53-3/8" x 38-5/8" x 6"	51206-8528	32 lb	379.00
	AF51206-1045	White	40-3/8" x 26-5/8" x 6"	51206-1155	24 lb	295.00
	AF51206-1048	White	53-3/8" x 38-5/8" x 6"	51206-1158	32 lb	379.00
	AF51206-1046	White	46-3/8" x 32-5/8" x 6"	51206-1156	28 lb	300.00



Bieffe BF Line Flat File

This flat file is nearly indestructible yet easy to move with its sturdy casters. Unit features seven 2"H x 51"W x 33"D drawers, metal handles, chromed label holders, and a safety lock. Sheet metal with an epoxy finish. Overall dimensions with wheeled base: 30-1/4"H x 55"W x 38"D. Stackable. Made in Italy.

5 Drawer					7 Drawer				
NUMBER	COLOR	DRAWER SIZE	OUTSIDE DIMENSIONS	EACH	NUMBER	COLOR	DRAWER SIZE	OUTSIDE DIMENSIONS	EACH
A52118-1021	White	25-1/29" x 18-3/10" x 2"	29-1/2" x 20-4/5" x 16-1/25"	\$1129.00	A52118-1007	Black	51" x 36" x 2"	22-1/2" x 55" x 38"	\$1905.00
A52118-1023	White	40-1/2" x 28-7/10" x 2"	44-1/2" x 31-3/10" x 16-1/2"	1455.00	A52118-2022	Black	25-1/29" x 18-3/10" x 2"	29-1/2" x 20-4/5" x 22-3/5"	1499.00
A52118-1024	White	51" x 36" x 2"	55" x 38" x 16-1/2"	2187.00	A52118-2512	Light Gray	25-1/29" x 18-3/10" x 2"	29-1/2" x 20-4/5" x 22-3/5"	1499.00
A52118-2021	Black	25-1/29" x 18-3/10" x 2"	29-1/2" x 20-4/5" x 16-1/25"	1129.00	A52118-2515	Light Gray	51" x 36" x 2"	55" x 38" x 22-3/5"	1905.00
A52118-2023	Black	40-1/2" x 28-7/10" x 2"	44-1/2" x 31-3/10" x 16-1/2"	1455.00	A52118-1020	White	51" x 36" x 2"	22-1/2" x 55" x 38"	1905.00
A52118-2024	Black	51" x 36" x 2"	55" x 38" x 16-1/2"	2187.00	A52118-1022	White	25-1/29" x 18-3/10" x 2"	29-1/2" x 20-4/5" x 22-3/5"	1499.00
A52118-2511	Light Gray	25-1/29" x 18-3/10" x 2"	29-1/2" x 20-4/5" x 16-1/25"	1129.00					
A52118-2513	Light Gray	40-1/2" x 28-7/10" x 2"	44-1/2" x 31-3/10" x 16-1/2"	1455.00					
A52118-2514	Light Gray	51" x 36" x 2"	55" x 38" x 16-1/2"	2187.00					

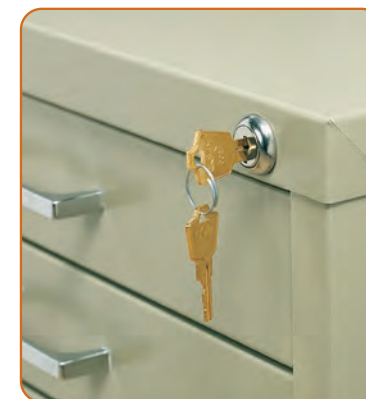

Safco Flat File Lock Kit

For use with Safco's 5-Drawer Steel Flat Files, when extra security or safety is required. FOB Factory. See page 648 for details.

NUMBER	EACH
AF51206-9000	\$108.50

Got a question about a product?
Our experts have the answer!
Three ways to connect —
Live Chat at DickBlick.com, call 800.933.2542,
or email info@DickBlick.com.



Richeson Flat Files

These beautiful flat files are great for storing and protecting your work. Stained in Golden Oak with a glossy finish, they complement almost any home or office setting. Each comes complete with cap and base, and the three- and five-drawer units can be safely stacked up to three files high. The solid oak drawer fronts feature brass drawer pulls. The drawer bottoms are hardboard. Drawers measure 2-1/4"H x 36-3/4"W x 25"D on the inside, large enough to hold sheets of paper up to 24" x 36". Assembly required. FOB Factory. See page 648 for details.

NUMBER	DESCRIPTION	OUTSIDE DIMENSIONS	EACH
AF51257-1003	3-Drawer	14"H x 41-1/2"W x 28"D	\$755.00
AF51257-1005	5-Drawer	20"H x 41-1/2"W x 28"D	865.00
AF51257-1008	8-Drawer	30"H x 41-1/2"W x 28"D	1352.00
AF51257-1010	10-Drawer	36"H x 41-1/2"W x 28"D	1445.00
AF51257-1015	15-Drawer	52"H x 41-1/2"W x 28"D	2165.00



Best Art Cart

This sturdy oak mobile cart is built to last. Design features include rounded corners for safety, craftsman quality joints, heavy-duty piano hinges, and a smooth hand rubbed finish. Comes with casters, two shelves, and two drawers. 36" wide x 25 1/2" deep, with a drawer size of 22" x 34". Ships fully assembled.

NUMBER	EACH
A51231-1000	\$1143.00



File Unit, 5 Drawers, Oak



Maple

Diversified Woodcrafts Flat File System

Protect and store artwork up to 24" x 36". Use each file cabinet as a standalone unit on a counter, or interlock up to three units together to create more storage. Add the veneered top for a finishing touch.

NUMBER	DESCRIPTION	COLOR	EACH
A52337-1003	Finished Top	Maple	\$171.88
A52337-1005	File Unit, 5 Drawers	Maple	1214.00
A52337-1002	Finished Top	Oak	122.77
A52337-1004	File Unit, 5 Drawers	Oak	1078.00
A52337-1001	File Base	Black Rubber	245.54

Diversified Woodcrafts Paper Storage Cabinet

Store large flat items, plus larger art and classroom supplies. This unit has two doors with a three-point locking system. Inside, it has seven large drawers with full extension glides, plus three shelves, two of which are adjustable. Each drawer can hold up to 100 lb. Chemical-resistant, earth-friendly UV finish and rubber base molding. 84"H x 48"W x 30"D.

NUMBER	COLOR	EACH
A52342-1010	Maple	\$2882.00
A52342-1020	Oak	2455.00



Oklahoma Sound Charging Storage Carts

Charge and store tablets and laptops in one convenient cart. Two recessed power strips charge half or all of your class's tablets and laptops. Slotted storage offers safe and healthy ventilation. The carts provide quick and easy access to tablets and laptops, and the doors can be locked for extra protection. High-pressure thermofused laminate finish. Four heavy-duty casters included.

NUMBER	SIZE	CAPACITY	EACH
A54996-2413	43-1/4" x 19-1/4" x 37"	24 Laptops	\$1361.00
A54996-2411	43-1/4" x 20" x 24"	24 Tablets	978.00
A54996-2412	36-1/4" x 23-1/4" x 18-1/4"	32 Tablets	927.00



Modern Watercolor	Page 621
DIY Watercolor Flowers	Page 621
Painting with Bob Ross	Page 621
Creative Watercolor	Page 621
The Art of Paint Pouring	Page 621
Pebeo Technical Book of Mixed Media	Page 627
Amazing Glaze	Page 628
Creative Lettering and Beyond	Page 628

Paper & Fabric Crafts	620
Painting	621
Art History DVDs	622
Art History	623
Drawing for Kids	624
Drawing	625
Walter Foster Painting	626
Mixed Media	627
Lettering, Sculpture & Ceramics	628

books & media



Crepe Paper Flowers

Craft peony petals, daffodil trumpets, and chrysanthemum blooms in no time! The book is filled with 30 projects, plus instructions and expert advice on the basics of crafting paper flowers and working with crepe paper. Lia Griffith. Paperback. 192 pages. 8-1/2" x 11".

NUMBER A75284-1002 EACH \$16.99



Cut and Create Paper Mosaics

Featuring 10 stunning mosaic patterns and all the paper you need to make each design, this relaxing, all-in-one project book is perfect for anyone interested in creating their own exquisite mosaics! Simply cut and assemble your mosaics following the included templates and instructions. Chiharu Rosenberg. Paperback. 32 pages. 8-1/2" x 11".

NUMBER A71529-1001 EACH \$19.99

Quilling Art

The centuries-old art of quilling gets a contemporary twist. Featuring tutorials for 20 stunning projects with easy-to-follow instructions, this book is a full-blown course in paper craft that will help you develop skills and techniques to create your own show-stopping designs. Sena Runa. Paperback. 136 pages. 8" x 10".

NUMBER A71319-1001 EACH \$19.95

Cutting Machine Crafts

Get the most out of your die cutting machine with this project book full of inspiration and expert advice. Create beautiful items using just about any electronic die cutting machine by downloading the SVG templates, running your materials through your machine, and following the instructions to assemble your cut materials. Lia Griffith. Paperback. 192 pages. 8-1/2" x 11".

NUMBER A75284-1001 EACH \$16.99

Dude Crafts

Create something new with items you already have. "Dude Crafts" is filled with 50 imaginative projects to solve a problem, to play a joke, or to create functional works of art and conversation pieces. Each project includes a parts list, step-by-step instructions, and photos to guide you as you create. Mike Warren. Hardcover. 192 pages. 6-3/4" x 9-3/4".

NUMBER A71534-1011 EACH \$20.99



Get Started in Leather Crafting

Discover leather crafting, an enjoyable craft that lasts a lifetime. This illustrated guide offers step-by-step techniques and tips from expert leather artists. Learn about tools and preparation, and explore essential techniques like stamping, tooling, and carving. The book also covers embossing, stitching, lacing, braiding, coloring, and more. Tony Laier and Kay Laier. Paperback. 48 pages. 8-1/2" x 11".

NUMBER A71297-1001 EACH \$9.99

LeatherWorks: Traditional Craft for Modern Living

This cool, contemporary craft book guides you through the core skills that will allow you to produce elegant and durable leather pieces, including hand-stitching, weaving, riveting, and lacing. Leather has intrinsic value and gives unique character to each piece you create. You'll learn to make homeware and fashion accessories, including a woven bench, a messenger bag, a glasses case, and an apron. Otis Ingrams. Hardcover. 144 pages. 8-1/4" x 10".

NUMBER A71277-1001 EACH \$29.99

Little Loom Weaving

Learn how to turn classic weaving techniques into trendy clothing and craft projects! Featuring creative patterns and step-by-step instructions, this guide includes color photos so both beginning and longtime weavers can learn to make something new. Andreia Gomes. Paperback. 128 pages. 7-1/2" x 9-1/4".

NUMBER A75296-1001 EACH \$16.95

Macramé Décor

Learn to create beautiful macramé pieces! Master a variety of knotting methods as you make fashionable, boho-inspired home décor. This book features 25 projects with step-by-step instructions and techniques. Create plant hangers, tapestries, dream catchers, and more — there's something of interest for everyone. Marchen Art Studio. Hardcover. 112 pages. 7" x 10".

NUMBER A75286-1004 EACH \$22.95

Gingko Press Woven Together

This collection of stories from 20 designers, artists, and craftsmen highlights the development of weaving throughout the years. Learn about a wide variety of projects, including traditional basket weaving, and find out about different production processes and detailed project patterns for bamboo, grass, and rattan. Sandu Publishing. Hardcover. 224 pages. 7-3/8" x 9-7/8".

NUMBER A71325-1001 EACH \$44.99

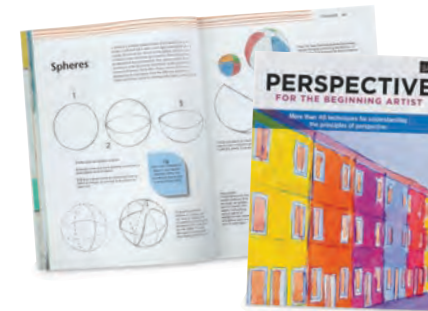

Perspective for the Beginning Artist

Learn how to "see" a subject. Learn the differences between one-, two-, and three-point perspective, as well as methods of how to measure and divide areas of a subject or scene proportionally. Mercedes Braunstein. Paperback. 128 pages. 8-1/4" x 11".

NUMBER A70495-1001 EACH \$19.95



Painting with Bob Ross

Learn to paint with Bob Ross, a cultural icon. In this guide, Bob introduces artists and aspiring artists to the basics of painting landscapes with his specially formulated oil paints. His "happy accidents" approach makes this challenging subject matter enjoyable for all skill and age levels. Bob Ross Inc. Paperback. 128 pages. 8-1/2" x 11".

NUMBER A70106-1129 EACH \$21.99



The Art of Paint Pouring

Discover the colorful, creative world of paint pouring. Explore a variety of techniques, including flip cup, dirty pour, swiping, and swirling on surfaces such as jewelry, bookmarks, and clay. Amanda VanEver. Paperback. 128 pages. 8-3/4" x 11-3/4".

NUMBER A67332-1001 EACH \$19.99



No Excuses Watercolor: Painting Techniques for Sketching and Journaling

Learn to go with the flow while you explore watercolor. Discover easy, new techniques and develop your personal style. It has an inspirational resource guide filled with prompts, reference photos, and more. Gina Rossi Armfield. Paperback. 128 pages. 8" x 10".

NUMBER A67300-1001 EACH \$24.99



Watercolor 365: Daily Tips, Tricks, and Techniques

Open this book daily to find a new tip, idea, technique, or challenge. Make watercolor part of your daily life while building skills, gaining confidence, and achieving creative happiness. Lessons cover everything from arranging your palette to setting artistic goals. Leslie Redhead. Paperback. 224 pages. 8-1/4" x 11".

NUMBER A67320-1001 EACH \$27.99



Drink Laugh Paint How to Host a Painting Party Kit

Whether you're serious about your art or just want to enjoy yourself, this kit is a wonderful mix of creativity and fun for both artists and novices. Included are a manual with step-by-step instructions, drink and party theme suggestions, a materials list, and postcard invitations. Jill Kerner Schon and Jackie Schon. Spiral-bound. 80 pages. 13" x 8-3/4" x 1-1/2".

NUMBER A75006-1194 EACH \$29.99



Creative Watercolor

A timeless medium gets a modern update. Learn to master essential techniques, including warm-up activities, layering, letting colors flow, and an introduction to creating multiple prints of your work. Includes tutorials and projects with step-by-step instructions in a practical yet fun approach. Ana Victoria Calderon. Paperback. 136 pages. 8-1/2" x 10".

NUMBER A67319-1005 EACH \$22.99



Modern Watercolor

A Playful and Contemporary Exploration of Watercolor Painting for Mixed-Media Artists and Creative Types This dynamic and inspirational guide sets you down a path of watercolor exploration. Learn to effectively use basic techniques and principles to create beautiful, expressive works of art. Kristin Van Leuven. Paperback. 128 pages. 8-3/4" x 11-3/4".

NUMBER A67319-1001 EACH \$19.99



DIY Watercolor Flowers

The perfect beginner's creative course in how to paint colorful flowers! Learn to paint a wide variety of flora and fauna and discover how to bring all your new skills together to create beautiful works of art. Marie Boudon. Paperback. 160 pages. 8-1/2" x 10".

NUMBER A67333-1001 EACH \$22.99

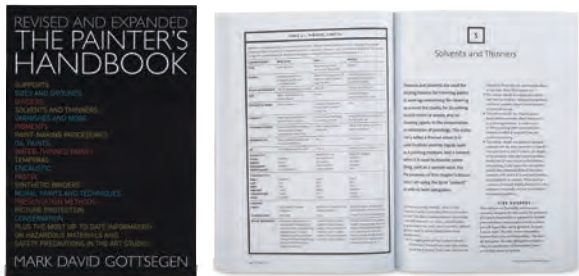

The Painter's Handbook

This updated edition provides information on everything from the canvas up, including the canvas itself, papers, pigments, binders, preservatives, solvents, thinners, and varnishes. It also features dozens of recipes with step-by-step instructions for making gessoes, paints, pastels, sizes, supports, varnishes, and more. Mark David Gottsegen. Paperback. 352 pages. 7" x 10".

NUMBER A69435-1001 EACH \$24.95

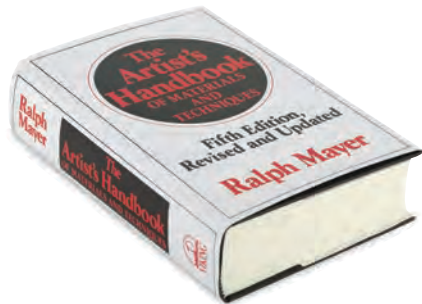

The Artist's Handbook of Materials and Techniques

Since its publication in 1940, this detailed guide has remained an invaluable resource for painters, sculptors, and printmakers of all levels. This updated edition has been expanded to reflect contemporary art movements, research, and technology. It features a user-friendly, encyclopedic format that makes finding information on a wide variety of basic and more technical information simple. Ralph Mayer. Hardcover. 784 pages. 9½" x 6½".

NUMBER A70130-1001 EACH \$49.99



NEW! Painting & Drawing: Techniques and Tutorials for Beginners

This book teaches beginners how to create with pencils and colored pencils, charcoal, acrylics, watercolors, and oil paints. Included is information about how to choose the right artists' tools and materials, tips on techniques, and step-by-step art tutorials. Editors of GMC. Paperback. 320 pages. 11" x 8½".

NUMBER A67326-1003 EACH \$29.95



Drawing on the Right Side of the Brain

Translated into more than 17 languages, no other manual has been quite so powerful in building artistic confidence, deepening perception, and fostering appreciation for the visual world. This fully revised and updated edition includes contemporary research on the brain and early childhood development, as well as new reproductions of master drawings throughout. Betty Edwards. Paperback. 320 pages. 7-1/4" x 9".

NUMBER A70501-1004 EACH \$19.99



The Colour Library Series

Explore the lives and works of the world's most celebrated artists with these detailed biographies. The perfect addition to any artist's library, each provides a comprehensive overview of the artists and the movements they helped shape. Paperback. 128 pages. 12" x 9".

NUMBER	DESCRIPTION	EACH
A72147-1001	The Colour Library: Dali	\$19.95
A72147-1002	The Colour Library: Klimt	19.95
A72147-1003	The Colour Library: Monet	19.95
A72147-1004	The Colour Library: Picasso	19.95
A72147-1005	The Colour Library: Van Gogh	19.95



Desperately Seeking Van Gogh

Perfect whether you're a Van Gogh enthusiast or a newcomer to this famous artist's work, this book offers a fresh approach to telling his story in an accessible, insightful way with fascinating information and commentary about his life and artwork. Ian Castello-Cortes. Hardcover. 112 pages. 5" x 7".

NUMBER A75222-1135 EACH \$18.95



Desperately Seeking Basquiat

Explore the most significant locations of Basquiat's life to find out who the artist was, where he came from, and where he liked to hang out. This book is full of photos, maps, commentary, and quotes from one of the most famous artists of the 20th century. Ian Castello-Cortes. Hardcover. 128 pages. 5" x 7".

NUMBER A75222-1136 EACH \$18.95



An Eye for Art

Focusing on Great Artists and Their Work

Written by curators at the National Gallery of Art, this book contains 40 fun activities to inspire the artist in every child. Projects include molding a clay figure inspired by Edgar Degas's sculptures; writing a story based on a Mary Cassatt painting; drawing an object from touch alone, inspired by Joan Miró's experience as an art student; and painting a double-sided portrait reflecting physical traits and personality traits, inspired by Leonardo da Vinci's Ginevra de' Benci. Paperback. 180 pages. 9" x 11".

NUMBER A69339-1001 EACH \$24.99



Children Should Know Series

Written for young readers, the "Children Should Know" series introduces children to great artists, artworks, and architecture in a fun and engaging manner. Various authors. Paperback. 48 pages. 9-1/2" x 11".

NUMBER	DESCRIPTION	EACH
A68342-1006	13 American Artists	\$14.95
A68342-1014	13 Architects	14.95
A68342-1012	13 Art Illusions	14.95
A68342-1010	13 Art Inventions	14.95
A68342-1015	13 Art Movements	14.95
A68342-1009	13 Art Mysteries	14.95
A68342-1016	13 Art Techniques	14.95
A68342-1003	13 Artists	14.95
A68342-1004	13 Buildings	14.95
A68342-1017	13 Impressionist Artists	14.95
A68342-1007	13 Modern Artists	14.95
A68342-1013	13 Painters	14.95
A68342-1002	13 Paintings	14.95
A68342-1008	13 Photos	14.95
A68342-1005	13 Sculptures	14.95
A68342-1001	13 Women Artists	14.95



You Should Know Series

These accessible and interesting reference guides provide practical art history lessons for everyone to enjoy. Subjects include great artists, famous artworks, and architecture. Various authors. Paperback. 176 pages. 9-1/2" x 7-3/4".

NUMBER	DESCRIPTION	EACH
A68341-1007	50 American Artists	\$19.95
A68341-1015	50 Art Movements	19.95
A68341-1001	50 Artists	19.95
A68341-1008	50 Buildings	19.95
A68341-1012	50 Contemporary Artists	19.95
A68341-1002	50 Paintings	19.95
A68341-1016	50 Photos	19.95
A68341-1017	50 Portrait Paintings	19.95
A68341-1020	Art Deco: 50 Works of Art	19.95
A68341-1021	Art Nouveau: 50 Works of Art	19.95
A68341-1005	Impressionist: 50 Paintings	19.95
A68341-1018	Pop Art: 50 Works of Art	19.95
A68341-1019	Surrealism: 50 Works of Art	19.95

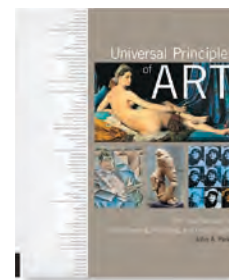

Universal Principles of Art

Containing a wealth of prompts, hints, insights, and road maps, the book is designed to open up a world of possibilities and provide invaluable keys to both understanding artworks and generating new ones. John A Parks. Hardcover. 208 pages. 8-1/2" x 10".

NUMBER A72127-1001 EACH \$34.99



NEW! The Art Book

This award-winning exploration of 600+ world-renowned artists spans from the medieval era to the present day. It features signature works by each artist, along with an overview of each creator and their work. It also debunks art-historical classifications by juxtaposing brilliant examples across periods, schools, visions, and techniques. A must for the art enthusiast. Phaidon Editors. Hardcover. 592 pages. 9-5/8" x 8-1/4".

NUMBER A70772-1001 EACH \$44.99



The Story of Art

One of the most famous and popular books on art ever written. "The Story of Art" presents the history of art as one unfolding narrative, from the earliest cave paintings to now. Written specially for newcomers to art, the book is accessible, informative, and fully illustrated. An unbeatable resource for anyone wanting to learn more about art history. E.H. Gombrich. Paperback. 688 pages. 9-1/2" x 6-3/4".

NUMBER A69862-1001 EACH \$39.95

Daily Warm-Ups

A wonderful way to turn extra classroom minutes into valuable learning time. The 180 quick activities — one for each day of the school year — encourage art appreciation with simple, hands-on assignments. "Art" details the importance of line, color, shape, texture, and balance. "Art History" covers key artists and great works. Paperback. 180 pages. 8-1/2" x 5".

NUMBER	DESCRIPTION	EACH
A71891-1001	Art	\$24.99
A71891-2001	Art History	24.99

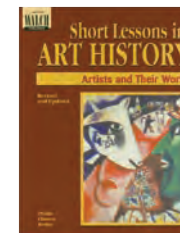

Short Lessons in Art History

Bring art to life with lessons that showcase the successes and struggles of legendary artists. Build an appreciation for major artists and movements, up to the present day. Includes biographies and a full color insert of art highlights. Phyllis Clausen Barker. Paperback. 217 pages. 8-1/2" x 11".

NUMBER A71816-1002 EACH \$29.99

Exercises and Activities for Short Lessons in Art History

This companion book works hand-in-hand with the title above. Provides interesting and engaging activities, plus questions geared to students' interests and abilities. Helps to develop critical thinking skills and increases students' awareness of artists and their work. Phyllis Clausen Barker. Paperback. 133 pages. 8-1/2" x 11".

NUMBER A71816-1003 EACH \$26.99

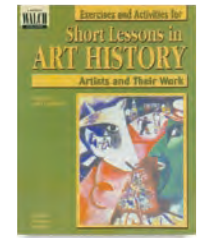



new!

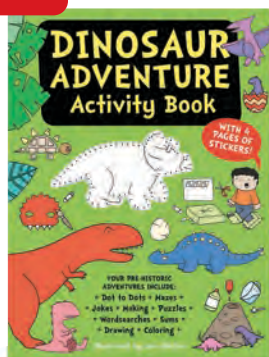

NEW! Adventure Activity Books

Great for beginners, these beautifully illustrated activity books feature fun and educational themes. They come packed with an array of creative activities, including mazes, paper crafts, coloring, stickers, and more. Paperback.

NUMBER	DESCRIPTION	EACH
A71184-1001	The Secret Woodland Activity Book	\$14.99
A71184-1002	The Magical Underwater Activity Book	14.99
A71184-1003	Space Adventure Activity Book	9.99
A71184-1004	Dinosaur Adventure Activity Book	9.99



Walter Foster' Learn to Draw Series

This award-winning series helps young artists age six and up learn to draw their favorite subjects with creativity and confidence. Using basic shapes as a starting point, these books demonstrate how to draw by building up forms, resulting in amazingly lifelike, full-color finished drawings. Simple step-by-step instructions make it easy. Educational fun facts are also included in each book so kids learn about the subjects they're drawing. Paperback. 64 pages. 8-1/2" x 11".

NUMBER	DESCRIPTION	EACH
A68163-1021	Birds & Butterflies	\$8.95
A68163-1014	Cats & Kittens	8.95
A68163-1017	Dinosaurs	8.95
A68163-1010	Dogs & Puppies	8.95
A68163-1019	Exotic Animals	8.95
A68163-1016	Forest Animals	8.95
A68163-1013	Horses & Ponies	8.95
A68163-1020	Military Machines	8.95
A68163-1011	Pets	8.95
A68163-1009	Polar Animals	8.95
A68163-1015	Safari Animals	8.95
A68163-1012	Sea Creatures	9.95
A68163-1018	Zoo Animals	8.95



Walter Foster' Cartooning for Kids Mashup Mania

Cartooning is great for young artists because of its expressive, sometimes silly, and often exaggerated nature. Kids as young as six can learn to be ace cartoonists thanks to this book. It's designed to help kids develop their cartooning skills through a series of engaging, easy-to-follow, step-by-step projects. Paperback. 64 pages. 8-1/2" x 11".

NUMBER	DESCRIPTION	EACH
A71143-1005	Cartooning for Kids Mashup Mania	\$8.95



Walter Foster' Cartoon Character Series

This series makes it easy to draw all your favorite Disney®, Disney-Pixar®, and Nickelodeon™ characters. Each book includes step-by-step instructions and illustrations, fun ways to use action lines, tips on outlining and coloring, and hints on how to create different poses and expressions. New steps are highlighted in blue so kids always know exactly what to draw next. Paperback. 8-1/2" x 11".

NUMBER	DESCRIPTION	EACH
A68196-1002	Best of Nickelodeon, 64 pages	\$9.95
A69523-1023	Classic Fairy Tales, 64 pages	9.95
A68120-1001	Disney Ultimate Collection, 144 pages	19.95
A69523-1020	Disney Classic Animated Movies, 144 pages	19.95
A69523-1016	Favorite Disney Pixar Characters, 64 pages	9.95
A69523-1012	Favorite Fairies, 64 pages	9.95
A68120-1002	Favorite Princesses, 144 pages	19.95
A69523-1022	Finding Dory, 64 pages	9.95
A69523-1021	Moana, 64 pages	9.95
A68196-1001	SpongeBob SquarePants, 64 pages	9.95
A69523-1014	Villains, 144 pages	19.95

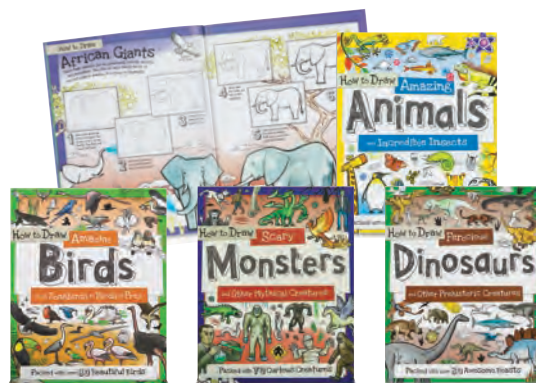

How to Draw Series

Each title in the How to Draw series features a range of 80 to 100 weird and wonderful drawing projects in a variety of kid-friendly categories. Easy, step-by-step instructions show kids how to draw out-of-this-world aliens, creepy-crawly creatures, fierce dinosaurs, and more! Fiona Gowen. Paperback. 32 pages. 8" x 10".

NUMBER	DESCRIPTION	EACH
A70281-1002	How to Draw Amazing Animals and Incredible Insects	\$4.99
A70281-1003	How to Draw Awesome Vehicles: Land, Sea, and Air	4.99
A70281-1004	How to Draw Ferocious Dinosaurs and Other Prehistoric Creatures	4.99
A70281-1005	How to Draw Incredible Sharks and Other Ocean Giants	4.99
A70281-1006	How to Draw Amazing Birds from Songbirds to Birds of Prey	4.99
A70281-1007	How to Draw Scary Monsters and Other Mythical Creatures	4.99

Walter Foster' Artist's Library Series

The books in this series will help beginning and advanced artists expand their creativity, overcome technical obstacles, and explore new media. Each title focuses on the materials and methods specific to each subject. Paperback. 64 pages. 6-1/2" x 9-1/2".

NUMBER	DESCRIPTION	EACH
A70106-1115	Color Theory	\$9.95
A70106-1030	Colored Pencil Step by Step	9.95
A70106-1050	Creative Cartooning	9.95
A70106-1120	Figure Drawing	9.95
A70106-1119	Mastering Pastel	9.95
A70106-1106	Pastels Step by Step	9.95
A70106-1003	Pencil Drawing	9.95
A70106-1040	Pencil Drawing Step by Step	9.95
A70106-1013	Perspective	9.95



Walter Foster' Drawing Made Easy Series

This series introduces budding artists to the fundamentals of pencil drawing. The first book in the series, "Getting Started," is the perfect introduction to the world of pencil drawing. Other basics, including values, textures, and composition, are covered in subsequent titles, which are then employed as artists build their skills and learn to draw landscapes, animals, flowers, lifelike people, and more. Various authors. Paperback. 64 pages. 6-1/2" x 9-1/2".

NUMBER	DESCRIPTION	EACH
A69555-1007	Beautiful Landscapes	\$9.95
A69555-1005	Dogs and Puppies	9.95
A69555-1010	Dragons and Fantasy	9.95
A69555-1006	Flowers and Botanicals	9.95
A69555-1012	Flowers in Colored Pencil	9.95
A69555-1015	Forest Animals	9.95
A69555-1001	Getting Started	9.95
A69555-1011	Horses and Ponies	9.95
A69555-1014	Landscapes in Colored Pencil	9.95
A69555-1009	Lifelike Animals	9.95
A69555-1008	Lifelike Heads	9.95
A69555-1013	Shortcuts & Artists' Secrets	9.95

Walter Foster' Collector's Edition Series

This compilation of simple projects from some of the most popular titles in the Walter Foster "How to Draw" series provides aspiring artists with the perfect introduction to drawing. Filled with step-by-step demonstrations and inspiring artwork, the books also offer a wealth of information about tools, materials, fundamentals, and advanced techniques that artists of all skill levels will find useful. Various authors. Paperback. 144 pages. 9" x 12".

NUMBER	DESCRIPTION	EACH
A68122-1001	Art of Basic Drawing	\$19.95
A71128-1001	Art of Calligraphy	19.95
A70748-1001	Art of Cartooning & Illustration	19.95
A70675-1001	Art of Colored Pencil	19.95
A68476-1001	Art of Drawing & Painting Portraits	19.95
A68113-1001	Art of Drawing Dragons	19.95
A70299-1001	Art of Drawing Manga & Comic Book Characters	19.95
A68111-1001	Art of Drawing People	19.95
A70106-1123	Botanical and Bird Illustration	19.99
A70106-1127	Drawing School Fundamentals for the Beginner	24.95



Walter Foster® Collector's Edition Series

The books in this series are filled with step-by-step demonstrations and inspiring artwork, as well as info about tools, materials, fundamentals, and advanced techniques. Whether your interest lies in watercolor, oil painting, or acrylics, artists of all levels will find a wealth of useful information in every volume. Various authors. Paperback. 144 pages. 9" x 12".

NUMBER	DESCRIPTION	EACH
A70488-1001	Art of Basic Oil Painting	\$19.95
A68151-1001	Art of Drawing & Painting Horses	19.95
A68476-1001	Art of Drawing & Painting Portraits	19.95
A70491-1001	Art of Painting Animals	19.95
A70492-1001	Art of Painting Flowers in Oil & Acrylic	19.95
A72912-1001	Art of Painting in Acrylic	19.95
A70699-1001	Art of Painting Sea Life in Watercolor	19.95
A70278-1001	Art of Painting Still Life in Acrylic	19.95
A70676-1001	Art of Watercolor Painting	19.95



Walter Foster® How to Paint Series

These books offer an introduction to basic techniques with step-by-step instructions. Each book also explains and illustrates various painting mediums and their uses. Paperback. 32 pages. 10-1/4" x 13-1/4".

NUMBER	DESCRIPTION	EACH
A70107-1190	Acrylic Animals	\$10.95
A70107-1073	Acrylic Landscapes	10.95
A70106-1125	Beginning Color Mixing	21.95
A70106-1124	Expressive Painting	21.95
A70107-1142	Oceans & Seascapes	8.95
A70107-1151	Special Subjects: Beginning Chinese Brush	10.95
A70107-1072	Waterscapes	10.95



Walter Foster® Artist's Library Series

The books in this series help beginning and advanced artists expand their creativity, overcome technical obstacles, and explore new mediums. Each focuses on materials and methods specific to each subject. Paperback. 64 pages. 6-1/2" x 9-1/2".

NUMBER	DESCRIPTION	EACH
A70106-1109	Acrylic Painting Step by Step	\$9.95
A70106-1060	Color Mixing in Acrylic	9.95
A70106-1115	Color Theory	9.95
A70106-1118	Mastering Oil Painting	9.95
A70106-1119	Mastering Pastel	9.95
A70106-1029	Oil Painting Step by Step	9.95
A70106-1117	Painting in Acrylic	9.95
A70106-1106	Pastel Step by Step	9.95
A70106-1013	Perspective	9.95
A70106-1028	Watercolor Painting Step by Step	9.95



The Complete Book of Mixed Media Art

Explore the many ways you can expand your artistic horizons with mixed media art. It features more than 200 mixed media techniques, including drawing and painting, stamping, stitching, collaging, and journaling. Each technique is presented with simple step-by-step examples and instructions. Walter Foster Creative Team. Hardcover. 240 pages. 12" x 9".

NUMBER	EACH
A70765-1001	\$24.95



Alternative Art Surfaces

Mixed Media Techniques for Painting on More Than 35 Different Surfaces

This book will entice you to try more than 35 diverse surfaces such as Plexiglas®, mica, concrete, glass, leather, and much more. Learn not only how to prep and paint on them but also how to encase, carve, adhere, transfer to, and print on them as well. Darlene Olivia McElroy and Sandra Duran Wilson. Paperback. 144 pages. 8-1/4" x 10-3/4".

NUMBER	EACH
A70762-1000	\$24.99



Pastel Innovations: 60+ Creative Techniques and Exercises for Painting with Pastels

Learn pastel painting techniques that are revolutionary, fun, and easy! Designed for beginners and experienced pastel artists alike, this book features innovative exercises and techniques that improve skills and build confidence. Dawn Emerson. Hardcover. 160 pages. 8-1/4" x 11".

NUMBER	EACH
A67321-1001	\$26.99



Doodle Art and Lettering with Joanne Sharpe

Create a more beautiful world with a little hand-lettered love. From selecting the best tools and supplies to forming your first simple letters, everything you need to begin your calligraphic journey is here. Joanne Sharpe. Paperback. 144 pages. 8-1/4" x 11".

NUMBER	EACH
A71106-1002	\$24.99

Pebeo Technical Book of Mixed Media

Dedicated to the extensive ranges of Pebeo mixed media products, this inspirational reference guide features complete Pebeo product descriptions, technical information, enhanced product usages and possible combinations, full color charts, helpful hints, and more. Pebeo in collaboration with Ed Roth. Wirebound with soft cover. 42 pages. 8-1/2" x 12-1/2".

NUMBER	EACH
A70763-1001	\$8.99



101 More Mixed Media Techniques

An Exploration of the Versatile World of Mixed Media Art

Another 101 mixed media techniques to spark your creativity! This book covers a variety of versatile, adventurous styles, including wabi-sabi painting and resists. Spiral-bound. 144 pages. 6" x 7-3/4".

NUMBER	EACH
A70759-1001	\$21.95

Playing with Image Transfers

Exploring Creative Imagery for Use in Art, Mixed Media, and Design

Learn how to reproduce images from virtually any source and apply them to a myriad of surfaces including wood, fabric, paper, canvas, and book forms. Covers four image transfer methods: packing tape, solvent, medium, and acrylic. Courtney Cerruti. Paperback. 144 pages. 8-1/2" x 10".

NUMBER	EACH
A71787-1001	\$24.99



Handmade Collage: 15 Stunning Designs to Cut and Assemble

A vast collection of nearly 500 images to browse, cut out, and create with. Getting started is simple. All you need is a glue stick, some paper or a card, a small pair of scissors, and this array of evocative images. Collage artist Seiko Kato's own designs provide inspiration. Seiko Kato. Paperback. 128 pages. 8-1/2" x 10".

NUMBER	EACH
A71276-1001	\$21.99



Create Your Life Book

Inspired by Tamara Laporte's popular online art classes, this book presents 18 step-by-step mixed media projects that help you expand creativity and overcome issues surrounding creative fulfillment. Tamara Laporte. Paperback. 144 pages. 8-1/2" x 10".

NUMBER	EACH
A71290-1001	\$22.99

LETTERING



The Complete Book of Calligraphy & Lettering

With step-by-step lessons, practice templates, and a range of alphabets, four professional artists guide you through traditional calligraphy techniques, as well as introduce contemporary hand-lettering art forms, such as brush lettering and mixed media, for a well-rounded approach to the craft. Cari Ferraro, Eugene Metcalf, Arthur Newhall, and John Stevens. Hardcover. 240 pages. 12" x 9".

NUMBER A70766-1007 EACH \$24.95



Creative Lettering and Beyond: Timeless Calligraphy

Discover a wide range of traditional lettering styles, learn the history of each hand, and find examples and ideas for using each style. Practice templates are included for perfecting your lettering. Laura Lavender. Paperback. 144 pages. 8-3/4" x 11-3/4".

NUMBER A71153-1003 EACH \$19.99



The Elements of Sculpture A Viewer's Guide

Featuring a vast range of examples, from classical Greek sculpture to notable contemporary works, this book is essential reading for anyone interested in looking at, experiencing, and discussing three-dimensional art. Herbert George. Hardcover. 192 pages. 9-1/2" x 8-1/4".

NUMBER A14961-1001 EACH \$39.95



Mastering Hand Building

This book covers all the foundational hand building skills with lessons for constructing both simple and complex forms from clay. It also details next-level techniques and tips — ideas for designing templates and replicating pieces, lidded vessels, using molds, decorative techniques, and other avenues of exploration are all inside. Sunshine Cobb. Hardcover. 208 pages. 8" x 10".

NUMBER A71014-1001 EACH \$31.99



How to Work with Ceramics: Easy Techniques and Over 20 Great Projects

An excellent potter's companion. From pinch pots, coil building, and slab construction to creative throwing practices and mold making, this must-have reference for ceramists covers all the basics. Collins & Brown (Editor). Paperback. 160 pages. 8-3/4" x 8-3/4".

NUMBER A14982-1002 EACH \$14.95



The Great Pottery Throw Down A Celebration of the Art and Craft of Ceramics

A complete introduction to the art and culture of ceramics, this book captures the passion and drama involved in turning lumps of clay into beautiful objects. The official companion book to the BBC series of the same name. Liz Wilhide and Susie Hodge. Hardcover. 224 pages. 6-1/4" x 9-1/4".

NUMBER A14982-1001 EACH \$29.95

Amazing Glaze

Discover how to make glazing less intimidating and more fun! Learn about the foundational techniques and correct tools for getting your glaze right every time. Includes dozens of recipes and combinations for both mid-range and high-fire glazes. Gabriel Kline. Hardcover. 200 pages. 8" x 10".

NUMBER A14977-1002 EACH \$29.99



Ceramics Timeline & Teacher's Guide

From writing surfaces to spaceship shields, this illustrated timeline traces the role of ceramics throughout history. By reviewing the images and timeline text, students discover the contribution of ceramics in visual arts, writing, history, geography, economics, and science from 35,000 BCE to the present. The teacher's guide provides discussion questions, classroom activities, a vocabulary list, and a bibliography. Set includes three 60" x 12" panels.

NUMBER A72901-1001 EACH \$58.95

A

Acetate Sheets	208-209
Acrylic	
Paint	30-37,39-42,44-45, 47,49-53,55,73-75
Sheets	252,354
Adhesive	
Applicator	547
Clips	608
Color Changing	553
Colored	550-551,553
Dots	349,541
Dry Mount	541
Epoxy	549
Film	540-541
Glitter	437
Glow in The Dark	437,553
Glue	452,462,547-555
Glue Gun	554-555
Heavy-duty	547-549
Hook & Loop Tape	608
Inkjet Paper	189
Kiln Cement	519
Laminating	540
Metallic	553
Mod Podge	552
Mosaic	472
Mounting	541
Paper	546
Paste	482,547
pH Neutral	253
PVA	253,462
Rubber Cement	547
School Glue	550-553
Sheets	541
Silicone	479
Skillet	555
Spray	396,542
Squares	541
Super	548-549
Tape	217,401,462,543-546
Washable	550-551,553
Wheat Paste	482,547
White Glue	462,551-552
Wood Glue	452,548-549,555
Air Purifier	539
Airbrush	
Accessories	357,362
Airbrushes & Sets	360-362
Cleaner	359-361
Colors	358-359
Compressors	360-361,363
Frisket	357
Paper	357
Spray Booths	364
Templates	357
Alabaster	494
Aluminum Tooling Foil	468-469
Anatomical Models	342-343
Antiquing	74,251
Aprons	17,78-79,510,539
Architecture Supplies	355-356
Archival Materials	
Art Bags	227,257
Mounting & Framing	226,228,230, 232,247,253
Painting Panels	154
Refill Pages	257
Storage Boxes	258
Armatures	485
Art	
Bags	227,253
Horse	578,586
Organizers	258-259,583,588, 590,612-618
Atomizer	84
Awls	417,426,428,461

B

Backdrop, Photo	595-596
Backpacks	406
Badge Making	447
Bags	
Acid Free	227,253,257
Canvas	406,413
Cotton	406
Mesh	256
Nylon	256
Plastic	486
Sand	494
Tote	256,406,413
Utility	256
Balsa Wood	356
Balusters	400
Bandanas	406
Banners	354
Barens, Printing	370
Barrier Cream	65
Baseball Caps	406
Bases, Armature	485
Basket Making	424
Basswood Blocks	356,453,492
Batik Tools	412
Bats, Clay	510
Beads	
Beading Loom	433
Clay	432
Glass	430-431
Glass Bead Making Kit	475
Pixelator	445
Plastic	431,442
Pony	432
Seed	430
Tools	429,485
Wooden	431
Beeswax	461
Bench	
Etching Press	386-387
Hook	373
Vise	585
Work	512,584-585
Bisque Ware	503
Blackboards	599-600
Blades	563-565
Blankets, Etching Press	386-387
Blending Stumps/Tortillons	337
Block Printing	366-375,377-380,383
Block-out Pens	402
Blocks	
Acrylic Paper	173
Carving	356,370,448,453,492,495
Foam Printing	368
Linoleum	366-367
Printing	366-370
Sanding	493
Styrofoam	448,495
Watercolor	166-169,171
Wood	356,370,450,453,492
Boards	
Adhesive Mounting	226
Art	147-148,150-159,171-172,203
Binders	460
Bristol	202-205
Bulletin	600-602
Chalk	589,599-600
Chipboard	222-223,226
Claybord	153-156
Clip	344
Cork	600-601
Corrugated	222-223
Display	224
Drawing	344-345,571
Foam	187,224-225,354
Gator	224

Gessoed	147-148,152, 154-155,158-159
Illustration	203
Macrame	425
Manga	205
Marker	203,598-599
Mat	230-235
Metallic	223
Mirror	223
Modeling	355,510
Mosaic Squares	436
Mounting	226
Multimedia	203
Pastel	156,178-179
Pebble Mat	226
Poster	222-223
Pre-cut Mats	227-230,232
Presentation	224
Printing	187
Project	224
Railroad	222
Sand Painting	446
Scratch	156,187
Sketch	344
Tag	223
Tile	204
Watercolor	153,165,167
Wedging	510-511
Bookmaking	
Awls	461
Binder	460
Bone Folder	461
Pixelator	445
Plastic	431,442
Pony	432
Seed	430
Tools	429,485
Wooden	431
Repair Kit	462
Rings	461
Screw Posts	461
Sewing Supplies	461
Books - see Separate Index	
Booth, Spray	364
Bottles	
Atomizer	84
Empty	84-85,408,446,521
Sand art	446
Squeeze	84,408,521
Boxes	
Art	258-259
Brush	139
Easel	573
Light	583,594-595
Mitre	355
Palette	81
Paper Mache	454
Pencil	259
Shadow	453
Storage	258-259,264
Tracing	583,594-595
Wooden	451,453
Brayers	372-373
Bristol Board	202-203,205
Brush	
Acrylic (natural)	60,93,96,100, 102-103,116-117,119-120, 123-124, 126-127,133,135,138
Acrylic (synthetic)	60,94-96,98-102, 106-107,110,112,115,118, 121-124,128-130,132-133,138
Bamboo	135,287
Bob Ross	60
Carriers	138-139
Ceramic	521
Class Packs	91,98-100,117-118,137
Cleaners	71,139-141

Color Shapers	136-137
Comfort	94-96
Decorative	106
Easel	103,117
Encaustic	134
Fabric Cleaning	400
Foam	137
Gesso	126,133,138
Glue	462
Hake	135
Holders	138-139
John Howard Sanden	60
Kids	94,96,99-107,116-122,137
Lettering	134
Mega	133
Oil (natural)	60,93,97-100,102, 104-106,116-117,119-120, 123-124,126-127,133
Oil (synthetic)	60,98-102, 110,115,118,121-124,128-130
Pastel	309
Pinstriping	134
Rubber Tip	86,131,136-137
Script	134
Sets	91,93-94
Sign Making	134
Silk Screen Cleaning	400
Softgrip	94-96
Special Needs	94,103,137
Stencil	134
Striping	134
Sumi	135-136
Utility	138
Washers	139,141
Watercolor (natural)	96,98,100, 102-107,109,126,135-136,138
Watercolor (synthetic)	92-99, 101-103,106-109,112-114, 128-129,133,136,138
Brush Pens	266,276-277,280, 282-283,288
Brush Sizing	140
Buckles	428
Bulbs, Light	591-592
Bulldog Clips	556
Bulletin Boards	600-602
Burlap	415,449
Burnishers	384,469
Butane Torch	477
Button Making Supplies	433,447

C

Cabinets	
Ceramic	512
Damp	512
Drying	512
Filing	616
Safety	539
Storage	539,612-615,618
Tray	612-613,615
Cable, Parallel Rule	345
Cadmium-Free Paint	24-25,62
Calipers	500
Calligraphy	135,181,186, 265,278,287-291
Candle Making Supplies	413,447
Cans, Waste	539
Canvas	
Art	142,144-146,148-149,160-161
Bags	406,413
Burlap	449
Clay	503
Drop Cloth	79
Linen	146
Mural	149
Pads	147,149,172-173
Panels	147-148,157-159,206
Paper	172-173
Plastic	415

Canvas Continued:	Chamois	337
Pliers	Charcoal	161
Printed Grid	Liquid	148
Sculpture	Pencils.....	495
Shapes	Powder.....	206
Stretched . 142,144-146,148-149,449	Sticks & Chunks.....	326-328
Stretchers	Chenille Stems.....	162
Yard Goods	Chipboard.....	160-161
Caps, Baseball.....	Chisels.....	406
Cards	Circle Cutters	224
Flash	Clamps, Screen Printing.....	444
Greeting.....	Clay	174-175
Printmaking	Air Dry	174
Cartooning	Bats	205
Cartridges, Ink	Bisque Earthenware	281,289
Carts	Calipers	513,519,586-590,616
Carving	Canvas.....	503
Stones	Claytoon.....	494
Tools & Sets	Cutters.....	493-496,563
Cases	Edger.....	498
Marker.....	Extruder.....	262,320
Pencil	Firing.....	320
Presentation.....	Glazes.....	254-257
Storage	Keepers	258-259
Trophy/Display	Kiln-fired.....	610-611
Castling Materials	Lid Master.....	500
Alginates.....	Liquid Polymer.....	481
Claycrete.....	Modeling.....	483
Epoxy.....	Modeling Boards	480
Glass	Molds	476
Mold Release	Oil-based	479-480
Papier Mache	Oven-bake	482-483
Plaster	Paper.....	481,483-484
Resin	Polymer	479-481
Rubber	Raku	479-481
Wax	Roller.....	480
Cellophane.....	Self-hardening	217
Cement	Shapers	497
Kiln	Stamps	519
Mosaic.....	Tools	472
Rubber	Transfer Paper	547
Ceramic	Turning Tools	499
Accessories.....	Wedging Angle & Board	78,476-477,499,506,510-511,519-521
Bead Tree	Claybord	520
Brushes	Cleaner	521
Carts.....	Air	513,519
Clay Container.....	Airbrush.....	513
Damp Cabinet.....	Brush	512
Drying Cabinet	Hand	512
Element Pins.....	Markerboard	520
Glazes.....	Paint.....	522-537
Gum Solution	Pen.....	522
Kiln Cart.....	Screen Printing Ink	513,519
Kiln Cement.....	Stain Remover	519
Kiln Shelves	Clip Board.....	515,517-519
Kiln Wash	Clips	477,519
Kilns	Adhesive.....	515-516,518-519
Pottery Wheels	Bulldog.....	508
Pyrometric Cones & Bars	Hanging.....	520
Safety Screen.....	Paper Holding.....	519
Spray Booth.....	Clock Making.....	364
Stilts	Clothes Pins.....	520
Tile Setters	Coasters.....	520
Tiles.....	Coatings, Spray	503
Wax Resist	Coiling Core	522
Work Table.....	Color Wheels.....	512
Chairs	Compass, Digital	580,587
Chalk	Compasses	349-351
Anti-dust.....	Composition Notebooks.....	201
Colored	Compressors, Air.....	360-361,363
Large	Cones, Pyrometric.....	520
Markers	Construction Paper	210-213,219-220
Sidewalk	Coping Saw.....	493
Tailors.....	Copper	417
Chalkboards.....	Plates	599-600
	Rods.....	485

Tooling.....	468-469	
Wire.....	429,485	
Cord	Beading.....	426,428,438
Coiling	424	
Cotton.....	425	
Elastic.....	428,438	
Hemp	425	
Jewelers.....	426,428,438	
Leather	426	
Nylon.....	428	
Polyester.....	428	
Screen Printing	401	
Setter.....	401	
Twine.....	425	
Cork.....	448,473,600-601	
Corrugated	Board	222-223
Paper.....	216	
Cosplay Supplies.....	478-479,486	
Cotton	Tassels.....	430
Warp.....	420-421	
Cray-pas	307-308	
Crayons	Ceramic Glaze.....	522
Coloring.....	302-304	
Conte.....	311,328	
Lithography.....	331,382	
Scented	302	
Underglaze	522	
Washable.....	302	
Water-soluble	304,309	
Crepe Paper.....	215,217	
Cricut Machine & Supplies.....	455	
Crimper.....	456	
Crochet Hooks	422	
Cups	Disposable.....	81
Palette.....	84-85	
Storage	82	
Curves	Flexible.....	353
French.....	353	
Irregular.....	353	
Cutters	Art Knife	563-564
Bottle.....	474	
Ceramic.....	565	
Circle.....	224	
Clay.....	492,499-500,510-511	
Curve.....	418	
Die-cut Machine	456	
Foamboard	224	
Glass	472,474	
Hobby Knife.....	564	
Linoleum.....	370-371,493,569	
Mat.....	236	
Metal.....	429,485,569	
Mosaic.....	472	
Paper.....	221,566-569	
Rotary.....	418,566	
Scissors.....	418,558-562	
Snap-off Blade	565	
Styrofoam	448	
Tile	472	
Trimmers	566-569	
Utility	565	
Wedging Angle.....	510-511	
Wire.....	429,485	
Wood.....	355,493	
X-Acto.....	563,568	
Cutting	Machine	455
Mat.....	562	
Pliers	429	

D

Decoupage Medium.....	552	
Degreaser	404	
Developer, Screen Printing Film.....	402	
Digital	Drawing Tablets	188,190
Paper.....	188-190	
Dip Pens.....	186,290	
Diploma Frames.....	246-247	
Dispensers	Adhesive.....	547
Blades.....	563	
Glaze	521	
Paint.....	84-85	
Paper.....	220-221	
Rubber Cement	547	
Tape	544	
Underglaze.....	521	
Yarn	421	
Display	Boards.....	224
Cases.....	610-611	
Easels.....	572,599	
Rails	608	
Systems	604-607,609	
Divider Screens.....	604-607	
Dowel Rods.....	356,425,450	
Drafting Supplies.....	209,335,339,344-349,351-352,543,582-583	
Compass.....	349,351	
Electric Eraser.....	339	
Film	209	
L-squares.....	349	
Lead Pointer	335	
Mechanical Pencils.....	335	
Parallel Board	345	
Parallel Rules.....	345	
Rulers.....	346-349	
T-squares.....	344	
Tables.....	582-583	
Templates.....	352	
Drape Molds	502	
Drawing	Aids.....	85,336-337,342-343
Board	344-345,571	
Board Cover.....	582	
Digital Tablets	188,190	
Gum	170	
Cordless.....	339	
Drafting.....	338-339	
Electric.....	339	
Graphite.....	337-339	
Ink.....	339	
Pencil	338-339	
Whiteboard	597	
Erasing Shield	337	
Etching	Ink.....	380,382
Ink.....	380	
Ink Varnish	383	
Plate.....	383	
Press.....	379,383,385-387	
Supplies.....	383-384,474	
Extruders, Clay.....	492,511	
Eyes, Wiggle.....	435	
EZ Cut Printing Blocks	369	
F		
Fabric	Aida Cloth	415
Bandana.....	406	
Banner	354	
Book.....	460	
Burlap	415	
Cotton.....	406	
Felt.....	441	
Markers	414	
Muslin	415,595	

E

Easel	Aluminum.....	570,573,577
Backs.....	231	
Box.....	573	
Children's	589	
Chipboard.....	231	
Convertible.....	575	
Display.....	570,572,599	
Extension.....	577	
French.....	573	
Jullian.....	573	
Light	591	
Portable.....	570-571,573,575,589	
Sketchbox.....	570,573	
Studio.....	570,572-578	
Table	570-571,589	
Embossing	ArtEmboss	468
Heat Tool	296	
Metal.....	468-469	
Plates	305,468	
Powders.....	296	
Embroidery	Floss.....	416
Needles	417	
Scissors.....	418	
Emulsion	Coater.....	395,404
Photo.....	402,404	
Screen Printing	402,404	
Enamel	Kilns	477
Lettering	75	
Paints	75	
Sign	75	
Encaustics	72	
Engraver, Electric	478	
Envelopes.....	254	
Enzyme, Screen Printing	402	
Epoxy	Adhesive.....	549
Casting	480	
Sculpture.....	486	
Erasers	Chalk	306
Charcoal	338	
Cordless.....	339	
Drafting.....	338-339	
Electric.....	339	
Graphite.....	337-339	
Ink.....	339	
Pencil	338-339	
Whiteboard	597	
Erasing Shield	337	
Etching	Ink.....	380,382
Ink.....	380	
Ink Varnish	383	
Plate.....	383	
Press.....	379,383,385-387	
Supplies.....	383-384,474	
Extruders, Clay.....	492,511	
Eyes, Wiggle.....	435	
EZ Cut Printing Blocks	369	
F		
Fabric	Brass.....	469
Copper.....	469,474	
Coppertone.....	469	
Glitter.....	455	
Heat Activated	455	
Paper.....	217	
Rolls.....	468	
Tooling.....	468-469	
Fragrance	Candle & Soap.....	447
Frames	Cardboard.....	231,454

Paint.....	410-411	
Screen Printing	400-401	
Backs.....	354	
Silk	413	
Smart-Fab.....	440	
Strips.....	436	
Face	Form.....	438-439
Painting	14	
Face Shield.....	538	
Fasteners	Binder Clips.....	556
Hook & Loop.....	608	
Push Pins	408,556,608	
Faux Finishing	74,251	
Feathers	434	
Felt.....	441	
Felting Supplies	417,420	
Fettling Knife.....	448,497	
Files, Flat.....	616-618	
Filing Cabinet.....	616	
Film	Acetate	208
Adhesive.....	540	
Digital	189	
Drafting.....	209	
Dura-Lar	208	
Frisket	357	
Iridescent.....	217	
Laminating.....	540	
Masking.....	357,402-403	
Scratch-Art	185	
Screen Printing	402-403	
Shrink Wrap.....	253	
Stencil	208,540	
Transparency	598	
Finger Cots/Gloves	337	
Finger Paint	14	
Finishes	Antiquing.....	251
Decoupage	552	
Gloss	71,319,336,542	
Marbling	457	
Matte.....	71,319,336,542	
Resin	74	
Sign	75	
Stone.....	76	
Fixatives.....	71,309,319-320,336,542	
Flat Files.....	616-618	
Fleck Stone.....	76	
Fleece.....	420	
Flexible Curve	353	
Fluid Writer Pen.....	412	
Foam	Board	187,354
Carving	448,495	
Circles (3D-O).....	457	
Craft	440,443,448,482	
Masks.....	438	
Noodles	443	
Shapes	440,448,482	
Tape	543	
Foamboard	224-225,354	
Foil	Brass.....	469
Copper.....	469,474	
Coppertone.....	469	
Glitter.....	455	
Heat Activated	455	
Paper.....	217	
Rolls.....	468	
Tooling.....	468-469	
Fragrance	Candle & Soap.....	447
Frames	Cardboard.....	231,454

Clear Box.....	246
Decorate-a-frame Kit.....	231,454
Diploma & Document.....	246-247
Floater	242
Mat.....	231
Poster.....	247
Ready-made	157,237-247,250
Screen Printing	400
Section	248-249
Storage	246
Unfinished.....	250
Weaving.....	422-423
French Curves	353
Funnel	84,446

G

Gatorboard.....	224	
Gems	Acrylic	435
Gesso	30,38,46,48,163	
Gesso Board	147-148,152,154-155,158-159	
Gilding Materials	251	
Glass	Beads.....	430-431
Casting	476	
Clear	252	
Cutters.....	472,474-475	
Etching	474	
Framing	252	
Globs	476	
Grinders.....	475	
Markers	268,300	
Mosaics	470-472	
Paint.....	15,52,73	
Rods.....	475	
Sheets	474,476	
Slumping	475-476	
Stained	474-475	
Glassine.....	253	
Glaze	Ceramic.....	522-537
Class Packs	530	
Gum Solution	522	
Polymer Clay.....	490	
Raku	533	
Shellac.....	75	
Silkscreen.....	503	
Spray	75	
Tongs.....	522	
Wax Resist	522	
Glitter	Cardstock	210
Craft	437	
Foil	455	
Glue.....	437,552	
Paint.....	7,9	
Gloves	Disposable.....	79,402,472,538
Nitrile.....	79,402,538	
Plastic.....	538	
Safety	79,472,538	
Glue - see Adhesives	Goggles.....	472,538
Gold Leaf	251	
Gold Size	251	
Gouache.....	28-29,52,54	
Graphite	Paper.....	207
Pencils.....	315,329-335	
Powder	331	
Putty.....	331	
Sticks.....	331	
Greeting Cards.....	174-175	
Grinding Stone.....	287	
Grommet Machine	354	
Grout	472	

Gummed	Erasers	338
Tape	253,401,544	
Gun	Clay	492
Glue.....	554-555	
Heat	72,253,296,477	
Staple	557	
Gyotaku (Japanese fish Printing)	376	

H

Hammers	Stone Carving.....	494
Texture	469	
Hand Forms.....	342-343	
Handles, Lino Cutter	371	
Hangers, Picture	252,602,609	
Heat Guns	72,253,296,477	
Hinge Clamps	400	
Holders	Brush	138-139
Lead	335	
Pen.....	186,290-291	
Pencil	337	
Sign	231	
Sponge	499	
Hole Punch.....	556	
Hooks	Bench.....	373
Ceiling	425,608	
Crochet	422	
Heddle.....	422	
Horse, Art.....	578,586	

I

Illustration Boards	203	
Incredible Nib.....	170	
Ink	Alcohol	294,296
Block Printing	374-375,380	
Calligraphy.....	289,293	
Cartridges	281	
Claybord	156	
Drawing	74,281,289,291-294,296	
Etching	382	
India	292	
Intaglio.....	382	
Lithography.....	380,382	
Marker Refill	261	
Metallic.....	293,375	
Monotype.....	374,378-382	
Pads	295-296	
Pearlescent.....	293	
Printer Ink.....	374	
Screen Printing	374,393-396	
Spray	296	

Jewelry Making Continued:	
Buttons.....	433
Cords.....	426,428,438
Elastic.....	428,438
Sequins.....	435
Tassels.....	430
Tools.....	428-430,485
Wire.....	428-429
Jig, Wire Bending.....	428,485
Journals.....	166,191-193,195,201,427

K

Kilns & Accessories.....	477,515-517,519
Knitting Looms.....	422
Knitting Needles.....	422
Knives	
Art.....	563-564
Break-off.....	565
Carving.....	493,563
Ceramic.....	565
Fettling.....	448,497
Grips.....	564
Heavy Duty.....	563
Hobby.....	418
Painting/Palette.....	86-88
Retractable.....	563,565
Rotary.....	418
Scratch.....	186
Utility.....	565
X-Acto.....	563

L

L-Squares.....	349
Laces	
Leather.....	426
Plastic.....	428
Suede.....	426
Laminating Materials.....	540
Lead.....	335
Lead, Holders & Pointers.....	335
Leaf Printing.....	376
Leafing, Kits & Supplies.....	251
Leather.....	411,426-427
Cord.....	426
Crafts.....	426-427
Dye.....	427
Hides.....	427
Lace.....	426
Needle.....	426
Paint.....	411
Tools.....	426
Lettering Guides.....	353
Letters	
Stencil.....	353,449
Lid Master, Ceramic.....	500
Light Boxes.....	583,594-595
Light Bulbs.....	592
Light Tables.....	583,594
Lights	
Clip.....	591-592
Diazo Screen Printing.....	397
Easel.....	591
Magnifier.....	591-592
Photo Studio.....	596
Table.....	591-593
USB.....	592
USB Charging.....	593
Linoleum.....	366-369
Linoleum Block Stop.....	373
Linoleum Cutters.....	370-371,493
Litho Crayons & Pencils.....	331,382
Liver of Sulphur.....	469
Looms.....	422-423,433
Loopers, Pot Holder.....	423

M

Macrame.....	425
Magnetic Sheeting.....	354,447
Magnetic Strip.....	354
Magnets.....	447,556
Magnifiers.....	348,591-592
Mallets.....	493
Manga	
Boards.....	205
Layout Paper.....	204-205
Manikins.....	342-343
Marbling.....	457
Marker Board.....	598
Markers	
Airbrush Adapter.....	362
Blender (colorless) ..	261,263-264,276
Board.....	203,599
Brush.....	261,263,266,276-277, 280,282-283,288,414
Calligraphy.....	265,276,278,288
Chalk.....	268-269
China.....	334
Chisel Tip.....	274
Design.....	260-266,276-277
Double-ended.....	260-266,273,275-276, 278,288,297-298,413
Dry Erase.....	597
Empty.....	267,271
Fabric.....	413-414
Gel.....	300
Glitter.....	265-266,297,300
Layout.....	260-266,276
Liquid Mask.....	271
Metallic.....	269-270,272-275, 283,298,300
Multicultural.....	300
Oil-based.....	270
Opaque.....	270,273,300
Paint.....	267-273,414
Pigment.....	263
Poster.....	268,271-272,297
Projection.....	598
Retractable.....	275
Scented.....	15,297,299
Sign.....	268,271-272,274,297-298
Washable.....	276,297-301
Water-based.....	269-270,276-277, 280,297-298
Mask	
Foam.....	438
Hobby.....	538
Making.....	438-439
Marker.....	271
Paper.....	439
Paper Mache.....	438-439
Paper Pulp.....	439
Plastic.....	438
Safety.....	538
Screen Printing.....	403
Shakespeare.....	438
Super Hero.....	438
Watercolor.....	25,170
Masking	
Films.....	357,402-403
Tape.....	170,217,545
Mat	
Bead.....	428
Cutters.....	236
Felting.....	417
Surface Protector.....	79
Matboards.....	226-235
Mounting.....	226-227
Pre-cut.....	227-230,232
Mediums	
Acrylic.....	30,32,34,38, 43,46-48,50,55,75
Encaustic.....	72

Oil.....	60,65,67,70-71
Pouring.....	47-48
Water Mixable Oil.....	70
Watercolor.....	170
Wax.....	70
Metal	
Burnisher.....	384,469
Foil.....	468-469
Leaf.....	251
Punch.....	468-469
Tooling.....	468-469
Mezzotint Rocker.....	384
Mineral Spirits.....	71
Mirrors	
Craft.....	474
Mosaic Tile.....	470
Self-portrait.....	337
Mitre Box.....	355
Mixing Wheel.....	80
Model Scenery.....	355

Modeling	
Anatomical.....	342-343
Boards.....	355,510
Clay.....	486-491,506
Claytoon.....	487
Compound.....	443
Paste.....	43,48
Plastic.....	478
Tools.....	469,487,496-501
Wheels.....	508-509

Mold Making	
Plaster.....	483
Release Agent.....	479-480
Rubber.....	479-481
Wax.....	480
Molds	
Casting.....	480
Drape.....	502
Face.....	438
Metal Tooling.....	468
Mosaic.....	472
Press.....	463
Slumping.....	476
Soap.....	447
Stepping Stone.....	472-473

Mosaic	
Adhesive.....	472
Cement.....	472
Grout.....	472
Kits.....	473
Molds.....	472-473
Paper Squares.....	436
Pebbles.....	471
Tiles.....	470-472
Paper Pulp.....	471-472

Mounting	
Boards.....	222-223,226-227,230,541
Films.....	540-541
Presses.....	541
Mounts, Mat.....	227,230
Mug, Bisque.....	503
Mural Canvas.....	149

N

Needlepoint Canvas.....	415
Needles	
Beading.....	417
Bendable.....	417
Binder's.....	461
Embroidery.....	417
Etching.....	384
Felting.....	417
Knitting.....	422
Raffia.....	424
Sgraffito.....	497
Tapestry.....	417,424

Tjanting.....	412
Weaving.....	417
Nibs	
Calligraphy.....	291
Pen.....	290
Nickel Wire.....	429
Nippers, Tile.....	472

O

Oil	
Linseed.....	65,70
Mediums.....	65,67,70-71,140
Paint.....	56-69
Paintsticks.....	69
Pastels.....	307-309
Stand.....	67
Watersoluble.....	66-68
Origami Paper.....	458-459
Oven.....	492
Overhead Projectors.....	598
Overlay Film.....	208-209

P

Paddles, Clay.....	499
Pads	
Bond.....	572
Bristol Board.....	202,204
Canvas.....	147,149,172-173
Drawing Paper.....	193,195-199,204-205
Gray Scale.....	177
Ink.....	295
Lecturers.....	572
Marker.....	204-205,207
Newsprint.....	197,200
Palette.....	83
Paper.....	167,180,194,206
Pastel.....	176-177,179-180
Recycled Paper.....	199-200
Sketch.....	193-196,198-200,204-205
Tracing Paper.....	205-206
Watercolor Paper.....	165-169,171

Paint	
Acrylic.....	30-37,39-42,44-45, 47,49-53,55,73-75,411
Airbrush.....	358-359
Black Light.....	32
Bob Ross.....	60
Bulletin.....	74-75
Cadmium-free.....	25,45,62
Chalky Finish.....	76
Craft.....	34,73
Decorative.....	34,73
Dry Erase.....	598
Dry Pigments.....	74
Enamel.....	75
Encaustic.....	72
Fabric.....	410-412
Face.....	14
Finger Paint.....	14
Fluorescent.....	6,8-9,27, 31-32,41,49,51,54,74-76
Glass.....	14-15,52,73,75
Glitter.....	7,9,18
Gouache.....	28-29,52,54
Iridescent.....	34,41-42,45,49-52,54
Keeper.....	81-82
Leather.....	411
Lettering.....	74-75
Luminous.....	54
Markers.....	15,267-273,414
Metallic.....	4,7-9,18,27,31-32,34-35, 40-41,44,49-50,52,54,73-76
Multicultural.....	5
Oil.....	56-69
Outdoor.....	74-75
Pearlescent.....	20,34
Photo Coloring.....	58
Poster.....	15

Powder.....	14
Sign.....	74-75
Spray.....	76-77
Tempera.....	4-14
Textile.....	73,410-412
Thinner.....	71,140
Washable.....	7-9,14-15,17-18,26
Watercolor.....	16-27
Watersoluble/Mixable Oil.....	68
Window.....	14-15

Painting Accessories	
Aprons & Smocks ..	17,78-79,510,539
Atomizer.....	84
Cleaners.....	71,139-141,408
Color Wheels.....	80
Containers.....	82,84-85
Dispensers.....	81-82,84-85
Funnels.....	84,446
Gloves.....	79,472,538
Gray Scale & Value Finder.....	80,85
Painting Knives.....	86-88,399
Palettes.....	10,12,81-83,373
Pippettes.....	88
Swabs.....	88,437
Tube Wringer.....	85
Viewfinder.....	85
Paintsticks.....	13,69,659

Palettes	
Acrylic.....	83
Box.....	81-82
Disposable.....	83
Folding.....	81
Glass.....	373
Plastic.....	81
Porcelain.....	83
Tray.....	81,83

Panels	
Canvas.....	147-148,157-159
Claybord.....	153-156
Wooden.....	150-152,154-155,158-159
Pantograph.....	336

Paper	
Acrylic.....	173
Adhesive.....	189,546
Airbrush.....	357
Animal Print.....	218
Art Rolls.....	216,218-220
Artagain.....	196
Background.....	216-219
BFK.....	182
Bleedproof.....	204,207
Block Print.....	181-184,377
Bond.....	221
Bordette.....	216
Bristol Board.....	202-203
By-the-pound.....	466
Calligraphic.....	289
Canvas.....	172-173
Cardstock.....	210,213,219
Chalk.....	180
Charcoal.....	176-180
Chart.....	572
Circles.....	447
Clearprint.....	207,209
Collage.....	217,436
Computer.....	188-190
Construction.....	210-213,218-220
Corrugated.....	216
Cover.....	183
Craft.....	215-221,443
Crepe.....	215,217
Crimpers & Deco Cutters.....	456
Decorative.....	215,464-467
Digital.....	188-190
Drawing.....	179,192-201,204-205,210
Dry Erase.....	598

Easel Pads.....	572
Edgers & Shapers.....	560
Embossed.....	465-467
Etching.....	183
Fadeless.....	218-219
Finger Paint.....	14
Flame Retardant.....	220
Fluorescent.....	216,219
Foil.....	217
Folder.....	461
Glassine.....	253
Graph.....	206
Graphite.....	207
Greeting Cards.....	174-175
Color Wheels.....	188-190
Interleaving.....	253
Iridescent.....	217
Japanese.....	181,184,287
Kiln Shelf.....	476
Kraft.....	219-221
Layout.....	207
Light-sensitive.....	457
Manga.....	204-205
Manilla.....	200
Marker.....	204-205,207
Metallic.....	188,217-218,459
Mosaic Squares.....	436
Multicultural.....	464
Nature Print Paper.....	457
Newsprint.....	197,200-201,221
Oil Painting.....	172-173
Origami.....	458-459
Pads.....	166-167,180,193-194,204-206
Papyrus.....	465
Parchment.....	206,289
Pastel.....	176-180
Photo.....	188-189
Press.....	463
Printmaking.....	181-184,377
Pulp Forms.....	438-439
Rag.....	182
Reversible.....	218
Rice.....	287
Sand.....	492
Scrapbook.....	213
Scratch-Art.....	185-187
Seamless.....	216,219
Sketch.....	192-196,198-201,204
Strips.....	456
Sulphite.....	200-201
Sumi.....	181,287
Synthetic.....	172,184
Thai.....	467
Tissue.....	214-215,457
Tracing.....	172,205-207
Transfer.....	189,207,520
Transparent.....	172,206,217
Trays.....	436
Unryu.....	181,467
Utility.....	220-221
Vellum.....	206-207,209
Velour.....	180
Washi.....	215
Watercolor.....	164-169,171-172,192,195
Waterproof.....	172

Paper Making Supplies	
Handmolds.....	463
Kits.....	463
Press.....	463
Pulp.....	463
Crepe.....	456
Paper Pulp Forms.....	439
Paper Punch.....	456
Paper Trimmers.....	566-569
Drawing.....	231,454,482-483
Boxes.....	454

Frames.....	231,454
Shapes.....	454
Parallel Rules.....	344-345,349
Paste	
Art.....	547
Bisque Mending.....	506
Modeling.....	43,46,48
Wheat.....	482,547
Pastellos.....	310
Pastels	
Blenders.....	308-309,311
Conte Crayons.....	328
Fixative.....	309,336
Hard.....	310-311
Jumbo.....	311
Oil.....	307-309
Pencils.....	313
Sidewalk.....	311
Soft.....	310,312
Street Art.....	311
Pebble Board.....	226
Pebbles.....	446,471
Pedestals.....	483
Peephole Plugs.....	517
Pen Cleaners.....	289,292
Pencils	
Beginners.....	334
Blender.....	320-321,323,325
Carbon.....	326
Case.....	320
Ceramic Glaze.....	522
Charcoal.....	326-3

Printmaking	
Barens.....	370
Blankets.....	386
Blocks.....	366-369
Brayers.....	372-373
Burnishers.....	384
Cards.....	174
Drying Racks.....	388,390-392
Emulsion.....	402,404
Engraving.....	383-384
Etching.....	374,378-384
Exposure Unit.....	398
Film.....	402-403
Glass Palette.....	373
Gravers.....	384
Gyotaku.....	376
Inking Plate.....	373
Inks.....	374-375,378-382
Intaglio.....	374,378,381,384
Kits.....	375,397-398
Liners.....	384
Linoleum Cutters.....	370-371,493
Lithography.....	380,382
Mezzotint Rocker.....	384
Monotype.....	378-379
Paper.....	181-184,377
Plates.....	369,377-378,380,383
Presses.....	378-379,383,385-387
Registration Guides.....	404
Screen Cleaner.....	397,402-404
Screen Opener.....	400
Screen Printing Frames & Fabric.....	400-401
Screen Printing Units.....	405
Solar.....	407
Squeegees.....	399
Varnish.....	380
Projection Screen.....	598
Projectors.....	445,598
Proportional Wheel.....	350
Protectors, Sheet.....	227,257,598
Protractors.....	350-351
Pugmill.....	512
Pulp.....	463
Pumps, Paint.....	4,31,35
Punch	
Awl.....	461
Book Board.....	461
Leather.....	426
Metal.....	469
Paper.....	456
Screw.....	461
Purifier, Air.....	539
Push Pins.....	408,608
Puzzle Kit.....	457
Pyrometer.....	519
Pyrometric Cones.....	520

R

Racks	
Art.....	614
Board.....	223
Drying.....	388-392
Palette.....	10
Paper.....	220-221,614
Print.....	603
Screen Printing.....	388,390-392
Tempera.....	10
Tissue.....	214
Raffia.....	424
Rasps.....	495-496
Reed, Natural.....	424
Reflectors, Photo Studio.....	596
Releasing Agent.....	479-481

Resin	
Casting.....	479-481
Colored.....	480
Dye.....	480
Top Coat.....	74
Respirators.....	538
Ribbons.....	436
Ribs, Potter.....	498
Rings	
Book.....	461
Macrame.....	425
Rocks	
Crushed.....	446
Roller	
Clay.....	501
Foam.....	137,372
Rubber.....	372-373
Rolling Pin.....	510
Room Dividers.....	604-607
Rubber	
Bands.....	408,556
Cement.....	547
Cosplay.....	479
Liquid.....	479-481
Rollers.....	372-373,501-502
Rubber Bands.....	556
Rubber Cement.....	547
Rubbing Plates.....	305
Rubylith.....	402
Rug Yarns.....	420-421
Rugs, Kids Activity.....	445
Rulers.....	346,348-349,353,418
Curve.....	353
Flexible.....	353
Grid.....	348
Pica.....	348
Rolling.....	348
Triangular Scales.....	349
Yardstick.....	346,349,418

S

Safety Cabinet.....	539
Safety Cans.....	539
Safety Edge.....	349
Safety Glasses/Goggles.....	472,538
Salt, Fixative.....	413
Sand, Craft.....	444,446
Sanding Block.....	493
Sanding Stick.....	493
Sandpaper.....	492
Sandpaper Block.....	337
Scale Lumber.....	355-356
Scarves	
Cotton.....	406
Silk.....	413
Scissors.....	418,558-562
Scrapbook Paper.....	213
Scrapers	
Pottery.....	498,500
Utility.....	565
Scratchboard Materials.....	186-187
Screen Opener.....	400,402-403
Screen Printing Supplies.....	389,393-405
Screens	
Kiln.....	519
Pre-stretched.....	400
Projection.....	598
Screw Eyes.....	252,602
Screw Posts.....	461
Sculpture Epoxy.....	486
Sculpture Wire.....	354,443,485
Sealer, Water-based.....	75
Sequins.....	435
Setter, Plate/Tile.....	520
Sewing Supplies.....	415-418
Sgraffito Tools.....	495,497

Sharpeners	
Pencil.....	318,321-322,324,
Colored.....	337,340-341
Stones.....	384
Sheet Protectors.....	227,257
Shellac.....	75
Shells.....	446
Shrink Art.....	442
Shrink Wrapping.....	253
Shuttles.....	422
Sign & Display	
Banners.....	354
Brushes.....	126,134,138
Lettering.....	353
Magnetic Sheets.....	354
Sign Cloth.....	354
Sign Paint.....	74
Stencils.....	353
Vinyl.....	354
Sign Making.....	354
Silk Hoops.....	412
Sketch Boards.....	344
Sketch Pads.....	192,194-196,198-200
Sketchbooks.....	191-193,195,204
Skull.....	343
Slab Rollers.....	510-511
Slime Activator.....	553
Soap.....	140-141
Soap Making Supplies.....	447
Soapstone.....	494
Solder & Flux.....	474
Soldering Iron.....	468,474
Spatulas.....	399
Special Needs Products	
Brushes.....	94-95,103,137
Chalk.....	306
Crayons.....	302-304
Knife Grip.....	564
Markers.....	15,268,297
Pencil Grip.....	322
Pencils.....	317
Pottery Wheel.....	509
Scissors.....	558
Table.....	584
Tabletop Easel.....	589
Sponges.....	85,399,499
Spout Maker, Ceramic.....	500
Spray	
Adhesives.....	396,542
Booths.....	364
Fabric Paint.....	411
Fixatives.....	71,309,319,336,542
Ink.....	296
Paint.....	76-77
Shellec.....	75
Stain.....	296
Tent.....	364
Varnish.....	71
Sprayer, Paint.....	360-362
Squeegees.....	399
Stained Glass.....	474-475
Stamps	
Clay.....	501-502
Stands	
Kiln.....	517
Lamp/Light.....	592
Modeling.....	495
Sculpture.....	495
Staple Guns.....	557
Staple Remover.....	556
Staplers.....	556-557
Staples.....	556-557
Stationary.....	174-175
Stencil	
Brushes.....	134
Craft.....	217,376,439

Letter.....	353
Sticks	
Charcoal.....	326-328
Glue.....	550
Graphite.....	331
Oil Paint.....	69
Popsicle.....	450
Sanding.....	493
Tempera.....	13
Stilts, Ceramic.....	520
Stone Carving Tools.....	494,496
Stones	
Alabaster.....	494
Scythe.....	475
Sharpening.....	384
Soapstone.....	494
Sumi Grinding.....	287
Stools, Art & Drafting.....	579-580,588
Storage	
Bins.....	258,588,590
Boxes.....	258,264
Cabinets.....	512,583,612-615,618
Carts.....	588,590,616
Construction Paper.....	212
Containers.....	513,539
Marker.....	264
Paper Rolls.....	220
Portable.....	254,615,618
Shelves.....	612
Stacking.....	258,614
Straws, Art.....	443
Streamers, Crepe Paper.....	217
Stretcher Bars.....	162
String Art.....	426
Stuffing.....	415
Stumps, Blending.....	337
Styrene Sheets.....	252
Styrofoam	
Blocks.....	448,495
Bricks.....	448
Cutters.....	448
Sumi Brushes.....	135-136,287
Sumi Paper.....	181,287
Swabs.....	88,437

T

T-shirts.....	398,407
T-shirts & Board	
Printers.....	405
T-Squares.....	344
Tablecloths.....	79
Tables	
Art & Drafting.....	581-585
Children.....	590
Folding.....	580
Heated.....	72
for Special Needs.....	584
Light.....	583,594
Sit/Stand.....	587
Studio.....	512
Tablet, Pixelator.....	445
Taborets.....	586
Tackboards.....	601-602
Tag Board.....	223
Tape	
Artist.....	543-544
Book.....	462,544
Colored.....	217,543,545
Document Repair.....	462
Double-Sided.....	543-544,546
Drafting.....	543-544
Duck.....	545
Foam.....	543
Frame.....	253
Gaffer.....	543
Gummed.....	253,401,544
Hinging.....	253

Hook & Loop.....	608
Kraft Paper.....	401,544
Linen.....	253
Masking.....	217,543-545
Metallic.....	543
Packaging.....	543-544
Painter.....	543
Screen.....	401
Transparent.....	462,544,546
Washi.....	545
Watercolor.....	170
Tape Dispensers.....	544
Tape Measure.....	418
Tempera Paint.....	4-12,14
Templates	
Airbrush.....	357
Drafting/Drawing.....	343,352-353
Lettering.....	353
Primary Shapes.....	353
Thinner	
Lacquer.....	403
Paint.....	71,140
Rubber Cement.....	547
Thread	
Bookmaking.....	461
Sewing.....	416
Throwing Ribs.....	498
Throwing Sticks.....	500
Tie Dye.....	408,410,412
Tile Setter.....	520
Tiles	
Bisque.....	503
Ceramic.....	470,503
Glass.....	470,472
Metal.....	471
Mosaic.....	470,472-473
Tin Punch.....	468-469
Tissue Paper.....	214-215,457
Tjanting Tools.....	412
Tooling Foil.....	468-469
Tools	
Bookbinding.....	462
Carving.....	493-496,563
Clay Modeling.....	496-501
Cricut.....	455
Electronic Cutting.....	455
Engraving.....	384,478
Etching.....	383-384
Felting.....	417
Fluting.....	500
Glass Work.....	472,475
Glazing.....	522
Grommet.....	354
Hand Drill.....	478
Heated.....	72
Heidi Swapp.....	455
Jewelry.....	428-430,485
Leather Craft.....	426
Measuring.....	346-351,418
Modeling.....	469,492,497-499
Mosaic.....	471
Pottery.....	496-501
Rubber Tipped.....	86,131
Scratchboard.....	156,186
Sculpture.....	493-496,563
Shop.....	477-478
Wax Painting.....	72
Wood Carving.....	493,563
Woodburning.....	452-453
Tote Bags.....	256,406,413
Tote Trays.....	612
Towels, Flour Sack.....	406
Tracing Paper.....	172,206-207
Transfer Paper.....	207,520
Transparency Materials.....	598

Tray	
Art Table.....	581
Butcher.....	83
Cabinets.....	612-613,615
Marker Storage.....	264
Paper Pulp.....	436
Stacking.....	258,614
Tote.....	612
Triangles.....	350
Trimmers	
Foamboard.....	224
Paper.....	566-569
Trophy Cases.....	610-611
Truck, Ceramic Ware.....	513
Tub, Super.....	383,408,463
Tube Wringer.....	85
Tubes.....	257
Turpenoid.....	71,140
Turpentine.....	71
Tweezers.....	429
Twine.....	425

U

Underglazes.....	522-525
Utility Cart.....	513,588-590

V

Varnish	
Acrylic.....	43,48,71
Oil.....	71
Pourable.....	74,452
Spray.....	71
Vine Charcoal.....	327
Vise, Bench.....	585

W

Walker Picture System.....	609
Warp, Cotton.....	420-421
Wash-Up Solvent.....	403
Waste Can.....	539
Watercolor	
Boards.....	167
Crayons.....	309
Ink.....	294,654
Ink Crystals.....	26
Masking Supplies.....	25,170
Paint.....	16-27
Paper.....	164-169,171-172,
.....	192,194-195
Pencils.....	314-315
Scented.....	17
Watercolor (natural).....	111

Wax	
Batik.....	413
Beeswax.....	413,461
Mediums.....	70
Melters.....	412-413
Mold Making.....	480
Paint.....	72
Resist.....	522
Sculpture.....	495
Strips.....	443
Weaving Supplies.....	422-423
Wedging Board.....	510-511
Wheat Paste.....	482,547

Wheels	
Color.....	80
Decorating.....	506
Pottery.....	508-509
Wiggle Eyes.....	435
Willow Charcoal.....	326-327
Wipe-out Tool.....	497
Wipes.....	415
Wire	
Armature & Sculpture.....	354,429,
.....	443,485
Beadcraft.....	428-429

Bending Jig.....	428,485
Clay Cutter.....	499-500
Jewelry.....	428-429
Mesh.....	484
Picture Framing.....	252,602
Wire Cutter.....	429,485
Wood	
Balsa.....	355-356
Basswood.....	355-356,452-453,492
Birch.....	451,453
Blocks.....	356,370,450,453,492
Box.....	451,453
Dowel Rods.....	356,425,450
Glue.....	452,548-549,555
Pine.....	452
Plaques.....	451-453
Plywood Bases.....	370,424,492
Project Kits.....	450
Shapes.....	449-450,452-453
Sheets.....	356
Sign.....	453
Strips.....	355-356
Turnings.....	451

Woodworking	
Chisels.....	493
Dremel.....	478
Drill.....	478
Electric Engraver.....	478
Knives & Carvers.....	493,563
Mallets.....	493
Plywood.....	356
Rasps.....	496
Sandpaper.....	492
Wood Blocks.....	356,370,492
Woodburning Tool.....	452-453
Woodworking Supplies.....	449,452
Wool	
Felting.....	417,420
Work Benches.....	512,584-585
Wringer	
Tube.....	85

X

X-Acto Knives.....	563
--------------------	-----

Y

Yardsticks.....	349,418
Yarns.....	419-421

Z

Zipppers.....	415
---------------	-----

Brand Name Index

1

1-Shot	
Brush Cleaner.....	141
Enamels & Reducers.....	75

3

3M	
Adhesive Strips.....	252
Respirator.....	538
Sandpaper.....	492
Spray Adhesive.....	542
Sticky Notes.....	546
Tape.....	462,544

A

Acco	
Clips.....	556
Display Systems.....	606
Acme	
Animation Pegbar.....	205
Activa	
Casting Kit.....	483
Clay.....	488,506
Clay Cutter.....	492
Paper Mache.....	482
Plaster.....	483
Plaster Cloth.....	484
Scenic Sand & Boards.....	446
Tools.....	498

Aitoh	
Decorative Paper.....	465
Marbling Kit.....	457
Origami.....	458-459
Akua	
Inks.....	381
Modifiers.....	378
Pin Press.....	378
Printing Plates.....	378
Wiping Fabric.....	378
Aleene's	
Spray Adhesive.....	542
Tacky Glue.....	552
Allerair	
Air Cleaner.....	539
Alphacolor	
Charcoal.....	327
Pastels.....	310
Tempera.....	12
Alumicolor	
Drafting Scales.....	349
Drafting Tool.....	347-348
Alvin	
Chairs & Stools.....	580
Compass.....	351
Cutting Mats.....	562
Drawing Board Cover.....	582
Erasers.....	338
French Curves.....	353
Glue Dots.....	349
Lead Holder.....	335
Lead Pointer.....	335
Lettering Guide.....	353
Mesh Bags.....	256
Paintbrush Holder.....	138
Pantograph.....	336
Paral-liner.....	345
Pencil Sharpeners.....	340
Pencils.....	335
Protectors.....	227
Rulers.....	347,349
Sketch Boards.....	344
Storage Tubes.....	257
Task Board.....	224
Triangles.....	350
Amaco	
ArtEmboss.....	468

Beading Accessories.....	492
Bisque Fix.....	506
Ceramic Kilns.....	515
Clay.....	486,504-506
Clay Bats.....	510
Clay Tools.....	499-501
Flexwax.....	480
Friendly Plastic.....	483
Glass Palette.....	373
Glazes.....	522-524,526,528,530,532-533,535-537
Kiln Accessories.....	477,515,519-520
Mesh.....	484
Molds.....	502
Papier Mache.....	483
Pottery Wheels & Accessories.....	506
Rub'n Buff.....	251
Rubber Latex.....	480
Sculptamold.....	483
Underglaze Crayons.....	522
Underglaze Pencils.....	522
Underglaze Watercolors.....	522
Wax Resist.....	522
Wedging Board.....	510
Wireform.....	485
American Crafts	
Cardstock.....	213
American Easel	
Artists' Panels.....	151
Easels.....	574
Printing Blocks.....	370
Ampersand	
Boards.....	152-156
Frames.....	242
Inks.....	156
Shadow Boxes.....	453
Tools.....	156
Amsterdam	
Acrylic Paint.....	40
Inks.....	294
Apollo	
Projection Screen.....	598
Transparency Film.....	598
Aquabee	
Sketchbook.....	199
Arches	
Cover Paper.....	183
Drawing Paper.....	197
Oil Paper.....	173
Print Paper.....	184
Watercolor Paper, Rolls, Blocks.....	169
Armada	
Scissors.....	560
Armour Etch	
Etching Cream.....	474
Arnold Grummer	
Bookmaking.....	460
Paper Making Supplies.....	463
Arrow	
Staplers & Staples.....	557
Art Alternatives	
Art Boards.....	203
Modeling Board.....	355
Pens.....	279
Sanding Block.....	493
Art Spectrum	
Pastel Paper.....	177,180
Art1st	
Drawing Paper.....	197
Mixed Media Paper.....	194
Newsprint.....	197
Sketch Pads.....	197
Artbin	
Art Boxes.....	259
Brush Box.....	139
Marker Storage.....	264

Pencil Box.....	259
Totes.....	256
ArtGraf	
Graphite Powder.....	331
Graphite Putty.....	331
Artline	
Markers.....	268
Pens.....	277
ArtMolds	
Casting Materials.....	480-481
Mold Release.....	481
Artool	
Frisket.....	357
Awagami	
Paper.....	184
AWT	
Drying Cabinet.....	389
Drying Racks.....	388-392
Exposure Unit.....	398
Screen Printing Accessories.....	400-401,403-404

B

Badger	
Airbrush Compressor.....	363
Airbrush Paint.....	358
Airbrushes & Sets.....	360
Bailey	
Carts.....	513
Clay Extruder.....	511-512
Slab Roller.....	511
Beacon	
Rubber Cement.....	547
Beadalon	
Jewelry Making Supplies.....	428-429
Beadsmith	
Jewelry Supplies.....	428
Macrame Board.....	425
Bee Paper	
Bristol.....	204
Calligraphic Paper.....	289
Manga Paper.....	204
Mixed Media Paper.....	192
Sketch Pads.....	204
Watercolor Paper.....	171
BEST	
Easels.....	574
Stretcher Bars/Strips/Braces.....	162
Best-Test	
Rubber Cement & Thinner.....	547
Bic	
Markers.....	274,297
Pens.....	284,286
Bieffe	
Chair & Stool.....	580
Filing Cabinet.....	616
Flat Files.....	616
Bienfang	
Bristol.....	202
Calligraphic Paper.....	289
Canvas Paper.....	172
Cross-Section Paper.....	206
Drawing Paper.....	194
Marker Paper.....	207
Parchment Paper.....	206
Project Board.....	224
Sketchbooks.....	201
Tracing Paper.....	206
Watercolor Paper.....	166
Black & Decker	
Laminator.....	540
Black Ink	
Block Printing Paper.....	183,377
Decorative Paper.....	465,467
Blackwing	
Notebooks.....	193
Pencils.....	330

Blair	
Fixative.....	336
Spray Adhesive.....	542
Blick	
Acrylic Mediums & Glazes.....	30,43,55
Acrylic Paint.....	30-31,36-37,42
Adjustable Hands.....	342
Airbrush Sets.....	360-361
All-Media Paper.....	200
Aprons.....	78
Archival Storage Boxes.....	258
Art & Drafting Tables.....	581
Artists' Boards.....	147,157
Baren.....	370
Bed Plates.....	386
Block Printing Ink.....	375
Block Printing Supplies.....	366-367,369
Bristol.....	202
Brush Tube.....	139
Brushes.....	91-92,104-109,116-124,126,133-135,138,287,521
Canvas.....	142,144-146,160-161
Canvas Pads.....	147
Canvas Panels.....	147,157-159
Cardstock.....	211
Carving Foam.....	495
Charcoal.....	326
Clay.....	504-506
Colored Pencils.....	317,323
Compasses.....	351
Construction Paper.....	211
Craft Paint.....	55
Cutting Mat.....	562
Display System.....	227
Drafting Board.....	345
Drawing Paper.....	194,196,200
Drying Racks.....	391
Easels.....	570,572-573,575-576,589
Erasers.....	338
Etching Press Blankets.....	386-387
Etching Presses.....	383,386-387
Fixative.....	336
Foamboard.....	225
Frames.....	157,237-241,243,250
Frisket.....	25,170
Gesso.....	30,163
Glazes.....	527
Glue.....	550-551
Illustration Board.....	203
Inks.....	292
Knives & Blades.....	564
L-Squares.....	349
Linoleum.....	366-367
Linoleum Cutters.....	371
Manikins.....	342
Marker Ink Refills.....	261
Markers.....	260-261,298
Modeling Boards.....	510
Newsprint.....	200
Oil Mediums.....	70-71
Oil Paint.....	57,63
Painting Knives.....	86-87
Palette Paper.....	83
Palettes.....	81,83
Panels.....	158
Paper Mache.....	482
Pastels.....	310,312
Pebble Board.....	226
Pencil & Marker Case.....	320
Pencil Sharpeners.....	340
Pencils.....	332,334
Plaster.....	483
Portfolios.....	254-256
Posterboard.....	222
Pre-cut Mats.....	228-229
Presentation Boards.....	227

Print Racks.....	603
Printing Paper.....	181
Rulers.....	346-347
Screen Printing Supplies.....	398,400-401,405
Sculpture Wire.....	485
Sketch Boards.....	344
Sketch Paper.....	199
Sketchbooks.....	193
Squeegees.....	399
Storage Tote.....	259
Storage Tubes.....	257
Stretcher Bars/Strips.....	162
T-squares.....	344
Tabletop Easel.....	589
Taborets.....	586
Tape.....	543
Tempera Cakes.....	11
Tempera Paint.....	4-6
Tissue Paper.....	214
Tracing Paper.....	206
Triangles.....	350
Watercolor Paint.....	25,27
Watercolor Paper & Blocks.....	165,168
Wooden Panels.....	159
Zipper Bags.....	320

Blum	
Printmaking Blocks.....	368
Bob Ross	
Brushes.....	60
Mediums.....	60
Oil Paint.....	60
Bockingford	
Tinted Paper.....	171
Boogie Board	
eWriter.....	188
Books by Hand	
Bookmaking Supplies.....	460-462
Borden & Riley	
Airbrush Pad.....	357
Bleedproof Paper.....	207
Layout Paper.....	207
Vellum.....	206
Bordette	
Border.....	216
Bostitch	
Pencil Sharpeners.....	324,340-341
Boston	
Clips.....	556
Brea Reese	
Alcohol Ink.....	294
Waterproof Paper.....	172
Brent	
Carts.....	513,519
Clay Extruder.....	511
Pottery Wheels & Accessories.....	509
Slab Roller.....	511
Brusho	
Crystal Colors.....	26
Bulls Eye	
Latex Primer.....	75
Spray Shellac.....	75

C

C-Thru	
Compass.....	351
French Curves.....	353
Protractor.....	351
Rulers.....	348
T-square.....	344
Templates.....	352
Triangles.....	350
Cachet	
Portfolios.....	256
Camillia	
Watercolor Paint.....	16
Canson	
Acrylic Painting Paper.....	173
Art Boards.....	311,328
Art Papers.....	210
Blank Cards.....	174
Bristol.....	202
Canvas Paper.....	172
Digital Paper.....	190
Disposable Palette.....	83
Drawing Paper.....	196-197,200
Ingres Paper.....	179
Manga Boards & Paper.....	205
Marker Pads.....	204,207
Mi-Teintes Papers & Boards.....	179
Mixed Media Pad.....	194
Newsprint.....	200
Oil Paper.....	173
Pastel & Charcoal Papers.....	176
Printmaking Paper.....	182
Sketch Paper.....	194,205
Sketch Paper & Rolls.....	199,206
Sketchbooks.....	192-193
Tracing Paper & Pads.....	206
Vellum.....	207
Watercolor Boards.....	167
Watercolor Paper & Blocks.....	164,166-167,194
Caran D'Ache	
Colored Pencils.....	319
Brushes.....	28
Graphite.....	329
Metal Tin.....	320
Clay.....	487,489
Color Sticks.....	316
Construction Paper.....	210
Crayons.....	302-303,597
Fabric Markers.....	414
Finger Paint.....	14
Glitter Glue.....	437
Glue Sticks.....	550
Markers.....	297,300-302,597
Pastels.....	307
Pencils.....	314,316,334
Scented Watercolors.....	17
Scissors.....	560
Smocks.....	17
Tempera Paint.....	7
Washable Paint.....	7,17
Watercolor Paint.....	17
Chroma Inc.	
Acrylic Paint.....	34-35,40,75
Mediums.....	75
Tempera.....	9
Chromalux	
Bulbs.....	592
Light Stand.....	592
Chromark	
Poster System.....	298
Circuit	
Machine & Supplies.....	455
Claridge	
Folding Screens.....	606
Map Rail.....	608
Clay Boss	
Potter's Wheel.....	508
Clear-Lay	
Clear Films.....	209
Clearprint	
Graphic Art Paper.....	207
Vellum.....	209
Coates	
Charcoal.....	327
Colour Shapers	
Rubber-Tipped Tools.....	136-137
Conrad	
Etching Presses.....	385

Conte	
Charcoal.....	326
Crayons.....	311,328
Pastel Pencils.....	313
Pencils.....	329
Copernicus	
Drying Racks.....	388
Easel.....	589
Mobile Organizers.....	589-590
Copic	
Drawing Pens.....	286
Markers.....	264-265,276
Pens.....	282
Cosmos	
Print Paper.....	184
Cover-It	
Bookmaking Kits.....	460,551
Craftwell	
Airbrush System.....	362
Crafty Dab	
Paint Markers.....	15
Window Writers.....	15
Caligo	
Printing Inks & Supplies.....	374,381
Cranfield Caligo	
Printing Inks & Supplies.....	374
Crayola	
Acrylic Paint.....	33
Brush Pens.....	277
Brushes.....	103
Chalk.....	306
Metal Tin.....	320
Clay.....	487,489
Color Sticks.....	316
Construction Paper.....	210
Crayons.....	302-303,597
Fabric Markers.....	414
Finger Paint.....	14
Glitter Glue.....	437
Glue Sticks.....	550
Markers.....	297,300-302,597
Pastels.....	307
Pencils.....	314,316,334
Scented Watercolors.....	17
Scissors.....	560
Smocks.....	17
Tempera Paint.....	7
Washable Paint.....	7,17
Watercolor Paint.....	17
Createx	
Acrylic Paint.....	34

Princeton	Studio Soap	141	Tempera Paint	9,13	Shiva						
Brushes	Tempera Cake Palette	12	Watercolor Paint	16,22,26	Brush Basin	139					
Rubber Tipped Tools	Tempera Cakes	10-12	Saturn	Drying Racks	390	Liquid Masque	170				
Prismacolor	Transfer Paper	207	Saunders Waterford	Watercolor Paper	171	Paintstik Oil Colors	69				
Charcoal	Watercolor Paint	16,18	Savage	Watercolor Paper	165	Shizen	Pastel Paper	176			
Erasers	Watercolor Paper	164	Background Paper	216,219	ShurTech	Watercolor Paper	165				
Lead Holders & Leads	Rising	Bristol Board	203	Mat Mounts	230	Tape	545				
Marker Case	262	Rit	Dyeing Supplies	409	Matboard	230	Silicoil	Brush Cleaning Tank	139		
Markers	262-263	Rives	Printmaking Paper	182	Photo Backdrop	595-596	Silver Brush	Brush Holder	139		
Pastels	311	Roaring Springs	Notebooks	201	Photo Lights & Accessories	596	Brush Holder	139			
Pencil Sharpener	324	Sketchbooks	198	Pre-cut Mats	230	Schacht	Spray Booth	364			
Pencils	314,324-325,332	Robert Simmons	Brushes	110,127	Schmincke	Looms & Supplies	422-423	Skutt	Ceramic Kilns	516	
Pens	282	Rotatrim	Paper Trimmer	566	Block Printing Ink	380	Schmincke	Ceramic Kilns	516		
Pro Art	Boxes	258	Rotring	Adhesive	550	Oil Mediums	70	Block Printing Ink	380		
ProMag	Magnets	447	Pens	281	Scissors	560	Scotch	Kiln Accessories	517		
Q	Quickomp	Drawing Tool	85	Royal & Langnickel	Brushes	94-97,115,521	Oil Paper	173	Kiln Stand	517	
R	R&F	Brushes	134	Brushes	94-97,115,521	Oil Paper	173	Block Printing Ink	380		
Encaustic Paint & Mediums	72	Encaustic Paint & Mediums	72	Oil Paper	173	Block Printing Ink	380	Oil Mediums	70		
Paint Accessories	72	Paint Accessories	72	Roylco	Basket Making	424	Cardstock	213	Scissors	560	
Pigment Sticks	69	Pigment Sticks	69	Basket Making	424	Cardstock	213	Film	185		
Rackaway	Drying Racks	391	Ranger	Crayons	309	Embossing Powders	296	Inks	292		
Ranger	Crayons	309	Embossing Powders	296	Inks	292	Knives	186			
Embossing Powders	296	Inks	294-296	Raphael	Brushes	128	Rembrandt	Pastels	312		
Inks	294-296	Raphael	Brushes	128	Rembrandt	Pastels	312	Rexlace	Crafts	428	
Raphael	Brushes	128	Rembrandt	Pastels	312	Rexlace	Crafts	428	RGM	Linoleum Knives	370
Brushes	128	Rembrandt	Pastels	312	Rexlace	Crafts	428	RGM	Linoleum Knives	370	
Rembrandt	Pastels	312	Rexlace	Crafts	428	RGM	Linoleum Knives	370	Richeson	Art Horse	586
Pastels	312	Rexlace	Crafts	428	RGM	Linoleum Knives	370	Richeson	Art Horse	586	
Rexlace	Crafts	428	RGM	Linoleum Knives	370	Richeson	Art Horse	586	Artists' Panels	150	
Crafts	428	RGM	Linoleum Knives	370	Richeson	Art Horse	586	Artists' Panels	150		
RGM	Linoleum Knives	370	Richeson	Art Horse	586	Artists' Panels	150	Block Printing Supplies	368		
Linoleum Knives	370	Richeson	Art Horse	586	Artists' Panels	150	Block Printing Supplies	368			
Richeson	Art Horse	586	Artists' Panels	150	Block Printing Supplies	368	Bookmaking Kits	460			
Art Horse	586	Artists' Panels	150	Block Printing Supplies	368	Bookmaking Kits	460	Brushes	102		
Artists' Panels	150	Block Printing Supplies	368	Bookmaking Kits	460	Brushes	102	Butcher Paper	221		
Block Printing Supplies	368	Bookmaking Kits	460	Brushes	102	Butcher Paper	221	Canvas Pliers	161		
Bookmaking Kits	460	Brushes	102	Butcher Paper	221	Canvas Pliers	161	Charcoal	326		
Brushes	102	Butcher Paper	221	Canvas Pliers	161	Charcoal	326	Clay Bats	510		
Butcher Paper	221	Canvas Pliers	161	Charcoal	326	Clay Bats	510	Clear Carve	368		
Canvas Pliers	161	Charcoal	326	Clay Bats	510	Clear Carve	368	Clip Board	344		
Charcoal	326	Clay Bats	510	Clear Carve	368	Clip Board	344	Cups	81		
Clay Bats	510	Clear Carve	368	Clip Board	344	Cups	81	Drawing Paper	201		
Clear Carve	368	Clip Board	344	Cups	81	Drawing Paper	201	Easels	574		
Clip Board	344	Cups	81	Drawing Paper	201	Easels	574	Etching Plate	383		
Cups	81	Drawing Paper	201	Easels	574	Etching Plate	383	Etching Tools	383		
Drawing Paper	201	Easels	574	Etching Plate	383	Etching Tools	383	Flat Files	618		
Easels	574	Etching Plate	383	Etching Tools	383	Flat Files	618	Inking Plate	373		
Etching Plate	383	Etching Tools	383	Flat Files	618	Inking Plate	373	Modeling Tools	496-498		
Etching Tools	383	Flat Files	618	Inking Plate	373	Modeling Tools	496-498	Neatness Jars & Tray	82		
Flat Files	618	Inking Plate	373	Modeling Tools	496-498	Neatness Jars & Tray	82	Newsprint	201		
Inking Plate	373	Modeling Tools	496-498	Neatness Jars & Tray	82	Newsprint	201	Oil Mediums	70		
Modeling Tools	496-498	Neatness Jars & Tray	82	Newsprint	201	Oil Mediums	70	Oil Paint	58		
Neatness Jars & Tray	82	Newsprint	201	Oil Mediums	70	Oil Paint	58	Painting Knives	88		
Newsprint	201	Oil Mediums	70	Oil Paint	58	Painting Knives	88	Palette Paper	83		
Oil Mediums	70	Oil Paint	58	Painting Knives	88	Palette Paper	83	Palettes	82-83		
Oil Paint	58	Painting Knives	88	Palette Paper	83	Palettes	82-83	Paper	184		
Painting Knives	88	Palette Paper	83	Palettes	82-83	Paper	184	Pastels	310		
Palette Paper	83	Palettes	82-83	Paper	184	Pastels	310	Pens	287		
Palettes	82-83	Paper	184	Pastels	310	Pens	287	Powder Tempera	14		
Paper	184	Pastels	310	Pens	287	Powder Tempera	14	Print Racks	603		
Pastels	310	Pens	287	Powder Tempera	14	Print Racks	603	Rubbing Plates	305		
Pens	287	Powder Tempera	14	Print Racks	603	Rubbing Plates	305	Stools	579		
Powder Tempera	14	Print Racks	603	Rubbing Plates	305	Stools	579	Street Stixs	311		
Print Racks	603	Rubbing Plates	305	Stools	579	Street Stixs	311				
Rubbing Plates	305	Stools	579	Street Stixs	311						
Stools	579	Street Stixs	311								
Street Stixs	311										

Screen Printing Ink	394-395	Staplers & Staples	556	Gesso	163	Glaze Applicators	521										
Screen Printing Kits	397	Talens	Acrylic Paint	33	Gouache Paint	29	Modeling Tools	496,498-499									
Screen Printing Supplies	400,404	Gouache	28	Gouache Paint	29	Oil Mediums	70-71										
Squeegees	399	Markers	266	Oil Paint	56,62	Oil Paint	56,62										
Sprayway	Spray Adhesive	396	Oil Paint	58	Stretch Strips/Cross Braces	162	Sponges	499									
Stabilo	Colored Pencils	317	Water Mixable Oil Paint	66-67	Watercolor Paint	25	Tools	497									
Colored Pencils	317	Pencils	313	Watercolor Paint	20-22,26	Watercolor Paint	25	Wedging Board	510								
Pencils	313	Pens	278	Testrite	Brayers	372	Xyron	Laminator	540								
Pens	278	Staedtler	Compasses	351	Display Easel/System	607	Yarka	Drawing Crayons	328								
Staedtler	Compasses	351	Erasers	339	Easels	577	Watercolor Paint	18,21-22									
Compasses	351	Markers	274	Safety Edge	349	Van Aken	Clay	487									
Erasers	339	Pencils	314,328,330,334	The Color Wheel Company	CMY Primary Mixing Wheel	80	Van Gogh	Oil Paint	56								
Markers	274	Pens	279,281	Color Wheels	80	Color Wheels	80	Oil Paint	56								
Pencils	314,328,330,334	Stanley	Staplers & Staples	556-557	Create-A-Color Wheel	80	Gray Scale & Value Finder	80	Pastels	308							
Pens	279,281	Star Products	Portfolios	255	StikkiWorks	Hanging Clips	608	The Masters	Brush Cleaner	140							
Stanley	Staplers & Staples	556-557	Stillman & Birn	Mixed Media Paper	192	Stillman & Birn	Mixed Media Paper	192	Therm-O-Web	Adhesive	541						
Staplers & Staples	556-557	Star Products	Portfolios	255	Stonehenge	Drawing Pads	197	Stonehenge	Drawing Pads	197							
Star Products	Portfolios	255	StikkiWorks	Hanging Clips	608	Stillman & Birn	Mixed Media Paper	192	Ticonderoga	Pencils	334						
Portfolios	255	StikkiWorks	Hanging Clips	608	Stillman & Birn	Mixed Media Paper	192	Stonehenge	Drawing Pads	197							
Stillman & Birn	Mixed Media Paper	192	Stonehenge	Drawing Pads	197	Print Paper	182	Watercolor Blocks	167	Special Needs Products	334						
Mixed Media Paper	192	Stonehenge	Drawing Pads	197	Print Paper	182	Watercolor Blocks	167	Storex	Storage Caddies & Trays	258						
Strathmore	Acrylic Paper	173	Art Journals	191	Black Chalk Paper	180	Blank Cards & Envelopes	175	Strathmore	Acrylic Paper	173						
Acrylic Paper	173	Art Journals	191	Black Chalk Paper	180	Blank Cards & Envelopes	175	Bristol	Canvas Paper Pad	172							
Art Journals	191	Black Chalk Paper	180	Blank Cards & Envelopes	175	Bristol	Canvas Paper Pad	172	Cardstock Tiles	204							
Black Chalk Paper	180	Blank Cards & Envelopes	175	Bristol	Canvas Paper Pad	172	Cardstock Tiles	204	Charcoal Paper	176-177,180							
Blank Cards & Envelopes	175	Bristol	Canvas Paper Pad	172	Cardstock Tiles	204	Digital Art Papers	188	Digital Art Papers	188							
Bristol	Canvas Paper Pad	172	Cardstock Tiles	204	Digital Art Papers	188	Drawing Paper	194-198	Drawing Paper	194-198							
Canvas Paper Pad	172	Cardstock Tiles	204	Digital Art Papers	188	Drawing Paper	194-198	Illustration Board	203								
Cardstock Tiles	204	Digital Art Papers	188	Drawing Paper	194-198	Illustration Board	203	Inkjet Paper	188								
Digital Art Papers	188	Drawing Paper	194-198	Illustration Board	203	Inkjet Paper	188	Marker Pads	204-205								
Drawing Paper	194-198	Illustration Board	203	Inkjet Paper	188	Marker Pads	204-205	Mixed Media Paper	195								
Illustration Board	203	Inkjet Paper	188	Marker Pads	204-205	Mixed Media Paper	195	Mounting Board	226								
Inkjet Paper	188	Marker Pads	204-205	Mixed Media Paper	195	Mounting Board	226	Newsprint	200								
Marker Pads	204-205	Mixed Media Paper	195	Mounting Board	226	Newsprint	200	Oil Paper	172								
Mixed Media Paper	195	Mounting Board	226	Newsprint	200	Oil Paper	172	Paper	184								
Mounting Board	226	Newsprint	200	Oil Paper	172	Paper	184	Pastel Paper	177								
Newsprint	200	Oil Paper	172	Paper	184	Pastel Paper	177	Printmaking Cards	174								
Oil Paper	172	Paper	184	Pastel Paper	177	Printmaking Cards	174	Sketch Paper	193-196,198-199								
Paper	184	Pastel Paper	177	Printmaking Cards	174	Sketch Paper	193-196,198-199	Sketchbook	196,198-199								
Pastel Paper	177	Printmaking Cards	174	Sketch Paper	193-196,198-199	Sketchbook	196,198-199	Tracing Paper	206								
Printmaking Cards	174	Sketch Paper	193-196,198-199	Sketchbook	196,198-199	Tracing Paper	206	Watercolor Paper	165-167								
Sketch Paper	193-196,198-199	Sketchbook	196,198-199	Tracing Paper	206	Watercolor Paper	165-167	Wet Media Pads	166								
Sketchbook	196,198-199	Tracing Paper	206	Watercolor Paper	165-167	Wet Media Pads	166	Studio Designs	Easel	572,577							
Tracing Paper	206	Watercolor Paper	165-167	Wet Media Pads	166	Studio Designs	Easel	572,577	Lights & Bulbs	592							
Watercolor Paper	165-167	Wet Media Pads	166	Studio Designs	Easel	572,577	Lights & Bulbs	592	Organizer & Tray	581							
Wet Media Pads	166	Studio Designs	Easel	572,577	Lights & Bulbs	592	Organizer & Tray	581	Tables	581							
Studio Designs	Easel	572,577	Lights & Bulbs	592	Organizer & Tray	581	Tables	581	Studio Pro	Glass Tools	475						
Easel	572,577	Lights & Bulbs	592	Organizer & Tray	581	Tables	581	Studio Pro	Glass Tools	475	Solder Iron	468,474					
Lights & Bulbs	592	Organizer & Tray	581	Tables	581	Studio Pro	Glass Tools	475	Solder Iron	468,474	Surebonder	Glue	554-555				
Organizer & Tray	581	Tables	581	Studio Pro	Glass Tools	475	Solder Iron	468,474	Surebonder	Glue	554-555	Glue Gun	554				
Tables	581	Studio Pro	Glass Tools	475	Solder Iron	468,474	Surebonder	Glue	554-555	Glue Gun	554	Glue Skillet	555				
Studio Pro	Glass Tools	475	Solder Iron	468,474	Surebonder	Glue	554-555	Glue Gun	554	Glue Skillet	555	Staple Gun	557				
Glass Tools	475	Solder Iron	468,474	Surebonder	Glue	554-555	Glue Gun	554	Glue Skillet	555	Staple Gun	557	Staplers	557			
Solder Iron	468,474	Surebonder	Glue	554-555	Glue Gun	554	Glue Skillet	555	Staple Gun	557	Staplers	557	Staples	557			
Surebonder	Glue	554-555	Glue Gun	554	Glue Skillet	555	Staple Gun	557	Staplers	557	Staples	557	Surehold	Super Glue	548		
Glue	554-555	Glue Gun	554	Glue Skillet	555	Staple Gun	557	Staplers	557	Staples	557	Surehold	Super Glue	548	Swingline	Hole Punch	556
Glue Gun	554	Glue Skillet	555	Staple Gun	557	Staplers	557	Staples	557	Surehold	Super Glue	548	Swingline	Hole Punch	556	Paper Trimmer	568
Glue Skillet	555	Staple Gun	557	Staplers	557	Staples	557	Surehold	Super Glue	548	Swingline	Hole Punch	556	Paper Trimmer	568		
Staple Gun	557	Staplers	557	Staples	557	Surehold	Super Glue	548	Swingline	Hole Punch	556	Paper Trimmer	568				
Staplers	557	Staples	557	Surehold	Super Glue	548	Swingline	Hole Punch	556	Paper Trimmer	568						
Staples	557	Surehold	Super Glue	548	Swingline	Hole Punch	556	Paper Trimmer	568								
Surehold	Super Glue	548	Swingline	Hole Punch	556	Paper Trimmer	568										
Super Glue	548	Swingline	Hole Punch	556	Paper Trimmer	568											
Swingline	Hole Punch	556	Paper Trimmer	568													
Hole Punch	556	Paper Trimmer	568														
Paper Trimmer	568																

Blick supports art education and makes ordering easier

Write a REVIEW!



Product reviews have become an important source of information for those who purchase art supplies and other products and services. Blick product reviews serve a variety of purposes, but most importantly, they give our customers a way to share their opinions with us — and to help fellow artists and teachers make future purchase decisions.



Lesson Plans & Video Library

Bring creativity to any teaching experience with Blick Lesson Plans. Created for all ages and skill levels, every project also meets National Core Arts Standards – Visual Arts. Download a PDF or view videos at DickBlick.com/lesson-plans.



Find 12 projects in our Lesson Plan Insert between pages 360 and 361!

ON-ACCOUNT PURCHASING AT DICKBLICK.COM

Who can purchase on-account at DickBlick.com?

Schools and businesses that have established an account with Blick and have completed a credit application may purchase on-account through our website. Visit DickBlick.com/customerservice/onaccount for instructions.

How do I set up an account if I don't already have one?

CONTACT OUR ORDER DEPARTMENT

Call the Order Department at 800-447-8192, Monday-Friday 7 a.m.–9 p.m., Saturday 8 a.m.–5:30 p.m., Sunday 9 a.m.–5:30 p.m. (CT) to speak with a Blick representative who will ask you to provide basic information about your school or company and then create an account for you over the phone.

SUBMIT A CREDIT APPLICATION

Call our Credit Department at 800-447-1892, Monday–Friday, 8 a.m.–4:30 p.m. (CT). Or download a credit application at DickBlick.com/customerservice/onaccount, then fax your completed application to 888-467-3190 or email to Credit@dickblick.com. After the application has been approved, you may begin placing orders online at DickBlick.com.

INTEGRATE YOUR ePROCUREMENT SYSTEM

If you use an eProcurement system and are interested in integrating it with our catalog, contact our Contract & Bid Department at 800-704-7744, Monday–Friday, 7 a.m.–4:30 p.m. (CT) or email Contracts@dickblick.com. You can easily download web content into a CSV file format, which is often compatible for requisitions and approvals within procurement systems. Simply click the Download Cart icon at the top of your shopping cart at DickBlick.com

How do I manage my account at DickBlick.com?

Simply visit DickBlick.com/statements. Under “Register Your Account,” type in your Customer # and zip code as they appear on your invoice or statement. You will be asked to enter your email address as your login ID and a password. That’s all there is to it! In the future, when logging in, type your email address and password in the “Returning Customer” area. From there you can:

- Instantly view, print, email, or save copies of any open invoice or credit.
- Pay open invoices by electronic check and generate a receipt.
- View your on-account balance and details.

Note: Once you’ve created your account, be sure to have your Computer/IT Department add our email address, Credit@dickblick.com, to the list of accepted email senders to prevent requested emailed invoices from being blocked by spam filters. Also, please share your login and password with your accounting supervisor.

Check out our many conveniences at DickBlick.com!



Teachers! Are you looking for an easy, cost-effective way to help your high school or college students stock up for the semester? Blick U Supply Lists are a great way to post everything they need, all in one place!

DickBlick.com/blicku



Quick Quote

New! Create a quote on-demand at DickBlick.com. Curate a shopping cart of needed items. Move cart items to a quick quote list. Immediately receive an official quote reflecting your account's profile and current prices.

DickBlick.com/educators/#Services

Scholastic Art & Writing Awards



Blick is proud to sponsor the prestigious Scholastic Art Portfolio Gold Medal Scholarship, provide awards to more than 70 Regional Art Affiliates and 1,000 Gold & Silver Medal teachers, and sponsor the yearly traveling exhibition. DickBlick.com/about-blick/gives-back

National and State Art Organizations



Blick is a Diamond Sponsor of the National Art Education Association Conference and awards two yearly grants so art educators can attend. State support includes resource exhibits, workshops, advertising support, free product samples, and more.

Youth Art Month



An annual observance held every March, Youth Art Month (YAM) emphasizes the value of art education for all youth and encourages support for quality school art programs. Blick is proud to support YAM events throughout the year. councilforarteducation.org/youth-art-month

DonorsChoose



Need art supplies for your classroom? Meet the funding community as big as your students' imaginations. Blick is honored to be a select vendor supporting the DonorsChoose vision: *We make it easy for anyone to help a teacher in need, moving us closer to a nation where students in every community have the tools and experiences they need for a great education.* donorschoose.org

School Discounts

If your school purchases a large quantity of art materials from Blick throughout the year, contact a Quote Specialist about discount eligibility for stocked items or to discuss your school's current discount status. **Phone 800-704-7744**
Monday–Friday, 7 a.m.–4:30 p.m. (CT)
Email Sales@dickblick.com

Bid Requests

If your organization requires official quotes or formal bids, our Contract and Bid Department is available to assist. **Phone 800-704-7744 Fax 800-621-8293**
Monday–Friday, 7 a.m.–4:30 p.m. (CT)
Email Sales@dickblick.com

Future Orders

A future order is a terrific way to have what you need, when you need it — without scrambling at the start of the semester. Simply send us your order and tell us when you'd like it to ship. We'll hold your supplies until that date, and you won't be invoiced until your order ships. Plus, product availability is much better when you order in advance!

health & safety information



THE ART & CREATIVE MATERIALS INSTITUTE, INC.

The Art and Creative Materials Institute (ACMI) is a non-profit trade association of art and craft materials manufacturers. Since 1940, ACMI has conducted a certification program in which product formulas are analyzed by a renowned toxicologist and certified by ACMI as non-toxic or properly labeled. ACMI certification also ensures compliance to state and federal labeling regulations.

Dick Blick is concerned about your safety. We are members of ACMI and we feel it is important that our products are certified under the ACMI program. Young children sometimes chew crayons, drink tempera, eat paste, or lick paint brushes. Adult products must bear the proper health and safety labeling to ensure that artists, hobbyists, and other consumers have lifelong health protection and safety information about the art materials they use.



Conforms to ASTM D4236

Products bearing the AP seal of the Art & Creative Materials Institute, Inc. (ACMI) are certified non-toxic. A medical expert evaluates each product and its ingredients. A product can be certified non-toxic only if it contains no materials in sufficient quantities to be toxic or injurious to humans, or to cause acute or chronic health problems. AP certification is reviewed by ACMI's Toxicological Advisory Board. These products are certified by ACMI to be labeled in accordance with the chronic hazard labeling standard, ASTM D4236 and federal law P.L. 100-695.

Dick Blick recommends that when you purchase art materials, particularly for classroom and institutional use, you should carefully consider the ultimate consumer. In cases where a product may be used in pre-school or primary school classes (K-6), or in environments with physically or mentally challenged persons who may be unable to read or understand safety labeling, you should purchase materials which are AP certified non-toxic products. This will ensure that even the most sensitive populations can safely enjoy art and craft activities.



Conforms to ASTM D4236

Products bearing the CL seal of the Art & Creative Materials Institute ("Caution Label") contain ingredients that are toxic or hazardous, but they can be used safely with appropriate caution. Materials that bear the CL seal should be used only by those persons who are able to read, understand, and follow suggested safety precautions for handling those materials. The Caution Label signifies that although the product contains a toxic element, it can be handled safely if the directions on the container or packaging are followed. Many such art products cannot be made non-hazardous, but are necessary for certain creative activities.

Many of the materials we sell are not reviewed by ACMI. We feel that it would trivialize the health and safety issues in the arts if we told you that scissors are sharp and kilns are hot. Our goal is to identify hazards that might not be known to our customers, and where possible, to identify safer alternative products. We also seek out products that promote health and safety in the arts, and we urge our customers to use them.

Some art materials manufacturers are not members of ACMI; this is particularly true of foreign manufacturers, from whom we import some of our finest color lines. Many of our office and graphic arts products, such as marking pens, adhesives, or screen printing chemicals, do not come from ACMI manufacturer's. Always read labels and instructions, and follow the manufacturer's guidelines for safe use. Young children should always have careful supervision when using art materials. Think of safety issues before you allow children to visit your studio. For products that do not have ACMI certification, we sometimes include a specific cautionary label of our own.

ACMI labeling indicates that a product has passed through a vigorous review process. Absence of the ACMI caution label does not indicate that a product is safe for use by children. Please read all labels and instructions before using art materials. Be an informed customer. We try to inform our customers of important health and safety issues, and we invite your comments on this issue.



ASTM

ASTM International, formerly known as American Society for Testing and Materials, is an international standards organization that develops and publishes voluntary consensus technical standards for a wide range of materials, products, systems, and services. Some 12,575 ASTM voluntary consensus standards operate globally. The standards presented here were developed by industry leaders in coatings and manufacturing plus scientists, artists and toxicologist for the betterment and safety of art materials.

ASTM D4236

The Standard Practice for Labeling Art Materials for Chronic Health Hazards describes a procedure for developing cautionary labeling for chronic health hazards in art materials. All art materials sold in the U.S. are required by Federal law (the Labeling of Hazardous Art Materials Act of 1988, also called LHAMA) to conform to this standard, and to display on the container label a statement to that effect: "Conforms to ASTM D4236."

ASTM D4236 requires that a qualified toxicologist, who determines which products must carry a warning statement and safe handling instructions, must evaluate all art materials. The standard includes tables of chronic hazards and precautionary statements that companies are required to place on product labels — these hazards and precautionary statements are based on current and developing knowledge that exists in the scientific and medical communities. The Consumer Product Safety Commission has been charged by Congress to enforce use of this standard.

ART MATERIALS FOR ALL AGES

Federal law requires that all art materials offered for sale to consumers of all ages in the United States undergo a toxicological review of the complete formulation of each product to determine the product's potential for producing adverse chronic health effects and that the art materials be properly labeled for acute and chronic hazards, as required by the Labeling of Hazardous Art Materials Act (LHAMA) and the Federal Hazardous Substances Act (FHSA), respectively. Art materials that are designed or intended primarily for children 12 years of age or younger must meet additional requirements (see below). After the chronic hazard review has been performed, the toxicologist will then recommend the appropriate statement to label that the product conforms to ASTM D4236. The FHSA also requires that a manufacturer affix cautionary labeling to art materials for certain acute and chronic hazards if those substances meet the definition of "hazardous substance" under the FHSA.

ART MATERIALS FOR CHILDREN UNDER 12 YEARS OF AGE & THE CPSIA

In addition to the LHAMA requirements detailed above, art materials that are designed or intended primarily for children 12 years of age or younger are also required to comply with the requirements of the Consumer Product Safety Improvement Act of 2008 (CPSIA). The CPSIA requires that manufacturers (this term includes importers) of children's art materials must test and certify compliance of such products before importing the products or distributing them in commerce. Manufacturers must submit samples of their product to a third-party laboratory whose accreditation has been accepted by the Consumer Product Safety Commission (CPSC).



WARNING

The State of California requires clear and reasonable warnings on products and/or storage containers containing chemicals that have been shown to cause cancer, birth defects, or other reproductive harm. Even if these products contain only trace levels of harmful chemicals, a warning is required by the State of California.

Manufacturers of certain products have included warnings pursuant to California Proposition 65, and caution is recommended when using products marked with the Prop 65 icon. For more information, go to P65Warnings.ca.gov. Products marked with either of these symbols (■ or ▼) carry the Proposition 65 warning.

metric to U.S. conversion

To compare the most common sizes of paint tubes, brushes, and other art materials, refer to the charts below.



CE MARKING

ASTM D4302
Standard Specification for Artists' Oil, Resin-Oil, and Alkyd Paints. A standard for the labeling, composition, physical properties, lightfastness and performance requirements for these types of paints. Artists' paints that conform to this specification will have the following statement on container labels: "Conforms to ASTM D4302."

ASTM D5067

Standard Specification for Artists' Watercolor Paints. A standard for the labeling, composition, physical properties, lightfastness and performance requirements for these types of paints. Artists' paints that conform to this specification will have the following statement on container labels: "Conforms to ASTM D5067."

ASTM D5098

Standard Specification for Artists' Acrylic Emulsion Paints. A standard for the labeling, composition, physical properties, lightfastness and performance requirements for these types of paints. Artists' paints that conform to this specification will have the following statement on container labels: "Conforms to ASTM D5098."

ASTM D5724

Standard Specification for Artists' Gouache Paints. A standard for the labeling, composition, physical properties, lightfastness and performance requirements for these types of paints. Artists' paints that conform to this specification will have the following statement on container labels: "Conforms to ASTM D5724."

POISON CONTROL CENTERS

If you have a poisoning emergency, call 1-800-222-1222. If the victim has collapsed or is not breathing, call 911.

By dialing the above toll-free telephone number, you will be connected to the closest poison control center to your calling location. All poison control centers and emergency room physicians in the U.S. have 24-hour access to toxicological information and generic formulas for products certified by The Art & Creative Materials Institute, Inc. (ACMI) on behalf of its members, including Dick Blick Art Materials. For additional poison control information visit www.aapcc.org.

Blick Art Materials
PO Box 1769
Galesburg, IL 61402-1769

Phone 1-309-343-6181
Fax 1-800-621-8293
sds@dickblick.com

VOC RESTRICTIONS

Due to state laws that place limits on the shipping of Volatile Organic Compounds (VOCs), Blick Art Materials cannot ship some sizes of paint thinners or multi-purpose solvents to addresses within the following states: California, Connecticut, Delaware, Maryland, New Hampshire, and Utah.

STORAGE TIPS FOR WATERBASED ARTISTS' COLORS

Paint products can become contaminated with bacteria or mold, which can lead to a strong, offensive and in some cases, sickening odor. Paints such as poster paints and temperas that are intended for classroom use, and for children, often contain an organic binder that is subject to degradation if not stored properly, or used within a reasonable period of time.

To guard against bacteria and mold, manufacturers of paint products add preservatives to these products. Diluting the product will decrease the effectiveness of preservatives. Below are some tips on storing paint products to maximize their shelf life:

- Store the product in its original container in a cool, dry place and prevent freezing.
- Date and rotate inventory, always using the oldest stock first.
- Thoroughly shake the product before using.
- Remove only enough paint for immediate use. Never return unused portions to the original container.
- Never dilute the product. The addition of water dilutes the preservative's strength as well as the paint. If diluting paint to simulate watercolor techniques, prepare only enough for immediate use.
- Avoid working directly from the original product container. Do not place brushes, hands, or other objects in the container.
- After each use, make sure the cap is returned tightly and that the product is sealed before storing.

All paints are subject to eventual spoilage once opened and exposed to air and other contaminants. Most spoilage is a result of cross-contamination from common sources such as air, water, people, brushes and other utensils. Proper storage and usage will reduce potential sources of contamination and extend the life of your paint.

LIQUID VOLUME		LINEAR	
MILLILITERS	U.S. LIQUID OUNCES	MILLIMETERS	U.S. INCHES
5	0.17	0.395	1/64
7	0.24	0.79	1/32
8	0.27	1.185	3/64
10	0.34	1.59	1/16
14	0.47	1.975	5/64
15	0.51	2.38	3/32
16	0.54	2.765	7/64
20	0.68	3.18	1/8
21	0.71	3.555	9/64
30	1.01	3.97	5/32
37	1.25	4.345	11/64
40	1.35	4.76	3/16
45	1.52	5.135	13/64
55	1.86	5.56	7/32
60	2.03	5.925	15/64
74	2.5	6.35	1/4
75	2.54	6.715	17/64
80	2.71	7.14	9/32
90	3.04	7.505	19/64
100	3.38	7.94	5/16
120	4.06	8.295	21/64
150	5.07	8.73	11/32
200	6.76	9.085	23/64
225	7.61	9.52	3/8
250	8.45	9.875	25/64
300	10.14	10.32	13/32
400	13.53	10.665	27/64
473	16 (1 Pint)	11.11	7/16
500	16.91	11.455	29/64
946	32 (1 Quart)	11.91	15/32
		12.245	31/64
1 Liter (1,000 ml)	33.81	12.7	1/2
		13.49	17/32
1.89 Liters	63.91 (1/2-Gallon)	14.3	9/16
		15.08	19/32
3.78 Liters	127.8 (1 Gallon)	15.88	5/8
		16.67	21/32
		17.46	11/16
		18.26	23/32
WEIGHT			
GRAMS	U.S. OUNCES		
1	0.04	19.05	3/4
5	0.18	19.84	25/32
10	0.35	20.64	13/16
20	0.71	21.43	27/32
30	1.06	22.23	7/8
40	1.41	23.02	29/32
50	1.76	23.81	15/16
		24.6	31/32
		25.4	1

customer service

PRODUCT QUESTIONS? WE HAVE ANSWERS!

We have five product information specialists to help you with questions about art materials, product applications, and techniques. Free color charts are available for many products, as well as sample swatches of most papers and boards. Please call our



Annette McClay
Product Information Supervisor

PRODUCT INFORMATION DEPARTMENT AT 800-933-2542

between 8 a.m. – 5:30 p.m. (CT), Monday–Friday, or email your question or request to info@dickblick.com.

TO REQUEST A CATALOG

Call 800-447-8192, 24 hours a day, seven days a week, email circulation@dickblick.com, or visit DickBlick.com.

SAFETY DATA SHEETS

In an effort to make SDS information more easily accessible to our customers, all Safety Data Sheets are now posted online and can be easily accessed directly from our product pages.

To submit a request for SDS by mail, phone, or fax, please specify the Blick item numbers and give a description of each product for which you need a data sheet. We will review your request and supply sheets for those items that require them. Direct your request to ATT: SDS Coordinator: Blick Art Materials, PO Box 1769, Galesburg, IL 61402-1769. You may also call 309-343-6181, send a fax to 800-621-8293 or email sd@dickblick.com.

ORDERING/ACCOUNT QUESTIONS

If you have placed an order but have not received it, or if you are checking on a backorder, call our Order Department at

800-447-8192

Monday–Friday, 7 a.m. – 9 p.m.
Saturday 8 a.m. – 5:30 p.m.
Sunday 9 a.m. – 5:30 p.m. (CT), or visit DickBlick.com.

DAMAGE AND SHORTAGE

Be sure to count parcels and inspect the shipment before signing the delivery receipt. If damage or shortage is apparent upon receiving your shipment, please note it on the delivery receipt. Have the delivery driver sign the receipt and verify that there is damage. Save the damaged package or carton for inspection.

Open all packages immediately and inspect merchandise to verify it is in good condition. If concealed damage (damage to materials inside a package with no external damage evident) is uncovered, notify us at once. Pictures of the damage is encouraged for all truck shipments. Check your merchandise against the packing slip. If an overage or shortage exists, we require you notify Blick Customer Service at

800-723-2787

within 30 days after receipt of the merchandise.

OUR RETURN POLICY

Blick will refund the full merchandise value up to one year from the time of purchase. For faster processing, we recommend items be returned within 30 days of receipt and in their original packaging and resalable condition. Return freight that is sent back to Blick is the responsibility of the customer unless: a) Blick Customer Service is notified within 30 days of receipt, AND b) the item received arrived damaged, OR c) the item received was not what was ordered. Factory direct merchandise returned as a result of a customer order error will be subject to a minimum 15% restocking fee and is the responsibility of the customer. Blick is not responsible for any lost or stolen packages.

For more ordering information, see page 643.



Natalie Ingle
Central, Southeast, Beyond US
Institutional Quote Specialist
RegionQuotes@dickblick.com



Jen Sholl
Northeast
Institutional Quote Specialist
RegionQuotes@dickblick.com



Cindy Howard
West
Institutional Quote Specialist
RegionWquotes@dickblick.com



Todd McGill
Tradeshows & Outreach Specialist
Tradeshows@dickblick.com



Heather Havens
Institutional Sales Manager
h.havens@dickblick.com



Tamby Peterson
Institutional Sales Supervisor
Contracts
Contracts@dickblick.com



Emily Weaver
Contract Specialist
Contracts@dickblick.com

Fax 800.621.8293 DickBlick.com **customer service** 647

visit a STORE near you!

Arizona

TEMPE
930 East University Drive
480-446-0800

California

BERKELEY
Custom Printing & Framing
1360 Tenth Street
510-486-2600

FULLERTON
601 North Placentia Avenue
714-528-8790

LOS ANGELES
Custom Printing & Framing
7301 West Beverly Boulevard
323-933-9284

OAKLAND
5301 Broadway
510-658-2787

PASADENA
44 South Raymond Avenue
626-795-4985

SACRAMENTO
905 Howe Avenue
916-641-6400

SAN DIEGO
1844 India Street
619-687-0050

SAN FRANCISCO
Custom Printing & Framing
979 Market Street
415-348-8600

SAN FRANCISCO
1930 Van Ness Avenue
415-409-1359

SANTA MONICA
Custom Printing & Framing
2602 Lincoln Boulevard
310-450-7015

WEST LOS ANGELES
Custom Printing & Framing
11531 Santa Monica Boulevard
310-479-1416

Connecticut
PLAINVILLE
341 Cooke Street
860-747-5551

DC, Washington
Custom Printing & Framing
1250 I Street NW
202-898-0555

Florida

FORT LAUDERDALE
2384 North Federal Highway
954-630-1482

MIAMI

Custom Printing & Framing
6250 South Dixie Highway
305-740-7077

TAMPA

Custom Printing & Framing
1502 North Westshore Boulevard
813-442-5079

Georgia

ATLANTA
878 Peachtree Street NE
404-347-9119

ROSWELL

Custom Printing & Framing
1165 Woodstock Road
770-993-0240

SAVANNAH

Custom Printing & Framing
318 East Broughton Street
912-234-0456

Illinois

CHICAGO LOOP
42 South State Street
312-920-0300

EVANSTON

Custom Printing & Framing
1755 Maple Avenue
847-425-9100

GALESBURG

695 US Highway 150 East
309-343-1411

LINCOLN PARK

Custom Printing & Framing
1574 North Kingsbury Street
312-573-0110

SCHAUMBURG

Custom Printing & Framing
500 East Golf Road
847-619-1115

WHEATON SHOPPING CENTER

79 Danada Square East
630-653-0569

Iowa

IOWA CITY
Custom Printing & Framing
201 South Clinton Street, Suite 180
319-337-5745

To learn more, visit:
DickBlick.com/stores

Maryland

BALTIMORE
229 West Chase Street
410-727-7004

Massachusetts

BOSTON LANDMARK CENTER
Custom Printing & Framing
401 Park Drive
617-247-3322

BOSTON MASS AVE

333 Massachusetts Avenue
617-262-4948

CAMBRIDGE

Custom Printing & Framing
619 Massachusetts Avenue
617-441-6360

Michigan

DEARBORN
14339 Michigan Avenue
313-581-7063

DETROIT

Custom Printing
4501 Woodward Avenue
313-833-9616

ROYAL OAK

28878 Woodward Avenue
248-548-7679

Minnesota

EDINA
Custom Printing & Framing
3867 Gallagher Drive
952-831-6061

ROSEVILLE

2389 Fairview Ave
651-636-2818

Missouri

KANSAS CITY
4144 Main Street
816-531-8410

ST. LOUIS

Custom Printing & Framing
6300 Delmar Boulevard
314-862-6980

Nebraska

OMAHA
7829 Dodge Street
402-397-6077

Nevada

LAS VEGAS
6300 West Charleston Boulevard
702-368-0209

New Jersey

PARAMUS
65 East State Rte 4
201-843-7702

New York

BROOKLYN FLATBRUSH
Custom Printing & Framing
41 Flatbush Avenue
646-809-6867

BROOKLYN MYRTLE AVE

536 Myrtle Avenue
718-789-0308

CARLE PLACE

Custom Printing & Framing
168 B Glen Cove Road
516-248-1555

HARLEM

Custom Printing & Framing
261 West 125th Street
212-222-7000

NEW YORK CITY 6th AVE

Custom Printing & Framing
650 6th Avenue
212-524-9611

NEW YORK CITY 13th ST

21 East 13th Street
212-924-4136

NEW YORK CITY W 23rd ST

237 West 23rd Street
212-675-8659

NEW YORK CITY BOND ST

Custom Printing & Framing
1-5 Bond Street
212-358-7788

NEW YORK CITY CHINATOWN

148 Lafayette Street
212-431-3864



Evanston, IL

Our Guarantee 100% Satisfaction

Blick's guarantee policy dates back to 1911, and we have no reason to change it. If you are not completely satisfied with the quality of the merchandise you receive, you are entitled to a full replacement or refund of the merchandise value up to one year from time of purchase. Details and limitations of our policy are listed below.



GIVE A BLICK GIFT CARD

When the perfect gift can't be found, order a gift card from Blick! Write the amount you wish to spend on the order form and submit payment in any of the usual ways. Print the name and address of the recipient and any special instructions, and we will mail the card to the recipient, or send it directly to you. You may also purchase gift cards on our website or by phone. Available in denominations from \$5 to \$500.

bids, quotes, discounts

CONTRACT, BID & QUOTE SPECIALISTS

We're here whenever you need assistance with volume pricing, bids, and quotes. Please contact us to discuss other partnership opportunities to help keep you well-stocked for creativity.

PHONE 800-704-7744

FAX 800-621-8293

Monday – Friday, 7 a.m. – 4:30 p.m. (CT)

SCHOOL DISCOUNTS

If your school purchases a large quantity of art materials from Blick throughout the year, contact our Institutional Quote Specialists for consideration of a fixed discount on all stocked items. Your school may already receive a discount, which may appear as a printed message on the back cover of this catalog. Please reference this code on your orders.

DISCOUNT EXCLUSIONS

Discounts apply to EACH prices as listed in this catalog only and do not apply to quantity prices or factory shipped items (FOB factory). Some items from the following brands may not be eligible for further discounts: 1 Shot®, Alvin®, Angelus®, Arches®, Artograph®, ArtResin™, Austin Air, Awagami®, Becca®, Canson®, Chameleon™ Art, Copic® Markers, Cretacolor®, Cricut®, Daylight, Derwent®, Do-A-Dot™, Enkaustikos®, Faber-Castell®, Fabriano®, Finetec, Gambin™, Gel Press®, Gelli Arts®, Glovies®, Golden®, Grex®, Hahnemühle, Iwata®, Kuttrimmer™, La Carte®, Lama Li, Liquitex®, M3D LLC, M Graham®, Mameri®, Moab™, Molotow™, Montana™ Gold, North Star, Paragon™, Plutonium™, R&F™, Raphaël®, Rembrandt®, Sennelier®, Snazaroo™, Stillman & Birn™, Terry Ludwig, Wexel™, and Winsor & Newton™.

Get the Lowest Prices, Guaranteed, with Web Match Rebate at Blick Stores!



Boston Fenway, MA



Tampa, FL



Brooklyn Flatbrush, NY

Prices and selection vary in our catalog, on our websites, and in our retail stores. All prices are subject to change without notice. Please do not send mail orders to store locations.

FREE SHIPPING on orders of \$49 or more!

Place your order any time, 24 hours a day, seven days a week!

TO ORDER BY MAIL:
Blick Art Materials
Attention: Order Department
PO Box 1769
Galesburg IL 61402-1769

When ordering by mail, please use the adjacent order form. Be sure to include:

1. "SOLD-TO" INFORMATION (the name and address of the party responsible for paying for the order), and the **"SHIP-TO" INFORMATION** (if the delivery of the order is to another party). To avoid billing errors, always use the same individual or institution name that you have used on previous orders. If you have your customer number, please include it on the order form — your order will be processed faster! (Your customer number may appear on the back cover of this catalog.)

2. METHOD OF PAYMENT. If you are paying with a credit card, fill in your complete number, expiration date, address to which your credit card company mails your statement, and sign your name on the signature line. If you are using

a mail order gift certificate, please indicate the amount of the certificate on the order form and enclose the gift certificate with the order. If you are using a gift card or e-gift card please include the number and amount.

3. ITEMS ORDERED. Fill in the entire item number and description of each item ordered. Also, include the quantity, page number, size/color, unit price, and total. For items ordered by the "set," indicate the number of "sets" desired — not the number of articles in the "set."

When you place an order through our catalog, we collect your name and contact information to record your purchase and fulfill your order. We also collect credit or debit card information to complete your purchase. For more information on how we collect and use your personal information, please see our Privacy Policy at <https://www.dickblick.com/privacy/> [dickblick.com]. <https://www.utrechtlart.com/info/customer-service/privacy/>

FOR CALIFORNIA RESIDENTS ONLY: If you are a California resident, you have certain rights under the California Consumer Privacy Act. For more information, including your right to opt-out of the sale of your personal information, please see our CA Privacy Rights policy at <https://www.dickblick.com/california-privacy-rights/> and our Do Not Sell My Personal Information notice <https://www.dickblick.com/california-privacy-rights/#Opt-Out>.

TO ORDER BY PHONE:
800-447-8192

Have your credit card number, customer number (if you know it), and your order form ready (as if you were going to mail it) — this will help us take your order more efficiently.

TO ORDER BY FAX:
800-621-8293 or 309-343-5785

TO ORDER BY EMAIL:
PurchaseOrders@DickBlick.com

TO ORDER ONLINE:
DickBlick.com or artmaterials.com
Schools can now make online purchases using approved open accounts and procurement cards. For more information, visit [DickBlick.com](https://www.dickblick.com) or phone toll-free 800-447-8192.

WRITTEN ORDER CONFIRMATION — When following up a phone, fax, or online order with a written order, please clearly indicate "Confirmation Only — Do Not Duplicate." The customer will be responsible for return freight and restocking charges for duplicate orders caused by failure to appropriately mark a written follow-up order.

AUDIO & VIDEO RETURN POLICY — We regret that we cannot give refunds on CDs and DVDs; all sales are considered final. In the event of a defective disc, we will replace it with an identical program.

GIVE A GIFT CARD!
Available in denominations from \$5 to \$500.



648 **terms** 800.447.8192 to order

GROUND SHIPPING/HANDLING CHARGES			
IF YOUR ORDER TOTALS	FEDEX ECONOMY	FEDEX HOME*** GET IT FASTER!	AK / HI / PR PRIORITY MAIL
\$0 – \$48.99	\$ 9.95*	\$13.95	**
\$49.00 – \$98.99	FREE*	\$4.00	**
\$99.00 & UP	FREE*	\$4.00	**
			PERCENT OF TOTAL ORDER

EXPEDITED SHIPPING/HANDLING CHARGES		
	FEDEX FAST 2 DAY	FEDEX EXPRESS ONE DAY AIR
CHARGE PER SHIPMENT (UP TO 1 LB)	\$22.95	\$29.95
CHARGE PER ADDITIONAL LB (UP TO 40 LBS)	\$1.40/LB	\$1.90/LB
CHARGE FOR SHIPMENTS OF 40 LBS OR MORE	TBD •	TBD •

TERMS OF PAYMENT — We accept personal and institutional checks, money orders, Blick gift certificates, PayPal, Amazon Payments, and VISA, Mastercard, Discover/NOVUS, American Express, Optima, Diners Club, and JCB credit cards. No C.O.D. shipments. No individual open accounts. Schools, institutions, government agencies, and businesses with suitable credit may be extended net 30-day payment terms (with accompanying purchase orders) upon approval of a credit application. Customers who don't maintain accounts within terms are subject to suspension or cancellation of credit. Credit customers may opt to use our Customer Account Website (DickBlick.com/statements) for 24/7 access to account details, to download/view/print/email copies of invoices, and to pay invoices with a credit card or e-check. Credit customers may register to receive invoices and statements by email. For a credit application, or for any other credit inquiry, contact Credit@dickblick.com or call **800-447-1892**.

CHECK POLICY: Upon receipt, your check may be converted into an electronic debit and processed according to Federal Reserve rules. Receipt of the check will be deemed to be your authorization for an Automated Clearing House (ACH) debit entry to your account, which in most cases will be posted to your account the following day. If your check is dishonored or returned for any reason, we will electronically debit your account for the amount of the check plus a legal limit of a processing fee as per state law.

PRICING/AVAILABILITY — All Prices Are Subject To Change Without Notice. Blick is committed to doing our best to make the necessary sacrifices so that prices in this catalog can be honored throughout 2022. In some cases, we may be able to lower prices if vendors do not raise prices to the extent estimated at the time of publishing this catalog. However, as vendors provide mid-year price increases, we cannot guarantee printed prices in this catalog — all prices are subject to change without notice. As of now, no more than a handful of products required mid-year adjustments, but this year may be an exception. Further, continuing supply chain disruptions have made it difficult to stay in stock on select items, and unfortunately vendors are taking much longer than usual to fill back orders. We ask for your understanding in these unprecedented times. As always, Blick reserves the right to typographical errors.

SHIPPING AND HANDLING CHARGES — Merchandise orders totaling \$49 or more ship freight-free via FedEx Economy whenever possible. Oversized or overweight orders will ship via a freight line. In those cases, the free freight offer includes curbside delivery only. Other services performed at the time of the delivery such as lift gate and inside delivery will incur additional charges. The average transit times will be extended for freight line deliveries and a delivery signature will be required. All other orders, see shipping charges above. **EXCEPTIONS:** Additional shipping charges will be added to factory-direct (FOB) shipments; oversized or overweight orders that require lift gate and/or inside delivery; international and U.S. Territory orders; and shipments to Alaska, Hawaii, and Puerto Rico. Shipment of the following stocked art materials will be billed at an additional cost: linoleum rolls; stretched canvas 36" x 36" and larger; oversized panels; select oversized frames; any combination of clay, plaster, and molding material totaling 50 lbs or more; packages of foamboard; all GBC Classiccut Ingento Cutters and Trimmers; the Blick 906 Model II Etching Press, the Blick 999 Model II Etching Press, the Blick Master Etch Model II Press, and all Blick Model II Benches; all kilns and pottery wheels; and some shelters. Paper or boards may be assorted to reach the quantity of 10. Some stocked furniture items will be shipped by truck and billed at an additional cost.

SHIPPING METHODS — Depending upon the items ordered and destination, shipments to a residential address may be delivered by the local post office. Oversized or overweight orders may ship via freight line. In those cases average transit times will be extended and a delivery signature is required. Items shipped using FedEx Fast2Day service will be received by the customer within two business days, and will be shipped via air or ground. Please note that hazardous items cannot be shipped to destinations outside the continental U.S. Schools should allow two to three weeks delivery time for orders placed from July 1 through September 30.

NOTE: Shipping offer is valid on orders from this catalog only.

*Residential shipments may be shipped by FedEx Economy, which is delivered by the USPS. **Orders shipping to Alaska, Hawaii, Puerto Rico, the Virgin Islands, APO/FPO addresses, and the U.S. Pacific Territories will require a freight quote, with a minimum charge of \$14.95. ***Only available for residential deliveries.

Note: Please provide both a physical and a mailing address if they are different. USPS Parcel Post is available only if you have no physical address (i.e., PO Box) and FedEx Economy charges will apply.

Due to continuing volatility in fuel costs, shipping charges are subject to change without notice.

• Items that have "AF" included in the item number will receive a freight quote for air shipment. Air orders shipping to Alaska and Hawaii, as well as orders with a total weight of more than 40 lbs, will receive a freight quote.

TRUCK SHIPMENT — Delivers your item to your curb or dock. The charge varies and is based on distance, weight, bulk, and other factors. A physical address and destination phone number are required for delivery. The minimum charge is approximately \$135. For an additional \$45, a smaller truck with a lift gate will lower your merchandise to the ground. For an additional \$30, your order can be moved from the curb to a ground-level location just inside your door. Delivery drivers cannot move items up or down stairs or to a specific location. Uncrating, disposing of packing materials, and installation are not included. Questions? Call 800-447-8192.

FOB FACTORY AND OVERSIZED ITEMS — Items that include "AF" in front of the item number will, in most cases, be shipped directly from the factory and will not qualify for our free freight offer unless otherwise stated. Additional shipping charges do apply for these items. If you have any questions call 800-447-8192. Please allow additional time for delivery. Some items shipped directly from the factory may not be available for express shipping.

ASSEMBLY/INSTALLATION — Blick is not responsible for unpacking, uncrating, unloading, removing, or disposing of debris, or for assembling or installing products.

PAPER & BOARD ORDERS — When ordering sheets of paper or board larger than 18" x 24" in quantities of less than 10, a per order handling fee applies. Paper or boards may be assorted to reach the quantity of 10.

SALES TAX — Pay your state's sales tax (if listed):

- AL - 8%
- AR - 6.5% plus city and/or county tax (also add tax on shipping)
- AZ - 5.6% plus city and/or county tax
- CA - 6% plus city and/or county tax
- CO - 2.9% plus city and/or county tax (also add tax on shipping)
- CT - 6.35% (also add tax on shipping)
- DC - 6%
- FL - 6% plus city and/or county tax (also add tax on shipping)
- GA - 4% plus city and/or county tax (also add tax on shipping)
- HI - 4% plus county tax (also add tax on shipping)
- IA - 6%
- ID - 6% plus city tax
- IL - 8.75% (also add tax on shipping)
- IN - 7% (also add tax on shipping)
- KS - 6.5% plus city and/or county tax (also add tax on shipping)
- KY - 6% (also add tax on shipping)
- LA - 4.45% (also add tax on shipping)
- MA - 6.25%
- MD - 6%
- ME - 5.5%
- MI - 6% (also add tax on shipping)
- MN - 6.875% plus city and/or county tax (also add tax on shipping)
- MO - 4.225% plus city and/or county tax (also add tax on shipping)
- MS - 7% (also add tax on shipping)
- NC - 4.75% plus city and/or county tax (also add tax on shipping)
- ND - 5% plus city and/or county tax (also add tax on shipping)
- NE - 5.5% plus city and/or county tax (also add tax on shipping)
- NJ - 6.625% (also add tax on shipping)
- NM - 5.125% (also add tax on shipping)
- NV - 4.6% plus city and/or county tax
- NY - 4% plus city and/or county tax (also add tax on shipping)
- OH - 5.75% plus city and/or county tax (also add tax on shipping)
- OK - 4.5% plus city and/or county tax
- PA - 6% plus city and/or county tax (also add tax on shipping)
- RI - 7% (also add tax on shipping)
- SC - 6% plus city and/or county tax (also add tax on shipping)
- SD - 4.5% plus city tax (also add tax on shipping)
- TN - 7% plus city and/or county tax (also add tax on shipping)
- TX - 8% (also add tax on shipping)
- UT - 4.85% plus city and/or county tax
- VA - 4.3% plus city and/or county tax
- VT - 6% plus city and/or county tax (also add tax on shipping)
- WA - 6.5% plus city and/or county tax (also add tax on shipping)
- WI - 5% plus city and/or county tax (also add tax on shipping)
- WV - 6% plus city tax (also add tax on shipping)
- WY - 4% plus city and/or county tax

BLICK ART MATERIALS BUSINESS PARTNERS

State and Regional Partners

Arizona

- 1GPA
- Strategic Alliance of Volume Expenditures - SAVE

California

- CalSave Monterey Co Office of Education - AEPA
- North-Cal Schools Joint Purchasing
- North Co Ed Purchasing Consortium - NCEPC

Colorado

- Colorado BOCES Association - AEPA
- Cooperative Educational Purchasing Council - CEPC

Connecticut

- Capitol Region Education Council - CREC/AEPA
- Connecticut Consortium for Cooperative Purchasing
- CT State Contract

Delaware

- Data Service Center

Florida

- PAEC Florida Buy - AEPA

Georgia

- Cooperative Purchasing Agency - AEPA

Indiana

- IAESC Procurement - AEPA - Wilson Education Center

Iowa

- AEA Purchasing - AEPA
- Iowa State Contract

Kansas

- Greenbush - AEPA

Kentucky

- Kentucky AEPA - Green River Regional Educational Cooperative
- Kentucky Purchasing Cooperative

Massachusetts

- The Education Collaborative (TEC)
- Massachusetts Higher Education Consortium
- Massachusetts State Contract

Maryland

- Maryland State Contract (Anne Arundel Co PS)

Michigan

- Oakland Schools Cooperative Contract Network - AEPA

Minnesota

- Cooperative Purchasing Connection - AEPA

Missouri

- Education Plus - AEPA

Montana

- Montana Cooperative Services - AEPA

Nebraska

- Nebraska ESU Coordinating Council - AEPA

New Hampshire

- Hampshire Council Purchasing

New Jersey

- Educational Data Services
- Educational Services Commission of NJ - AEPA
- New Jersey State Contract

New Mexico

- Cooperative Educational Services - AEPA

New York

- Educational Data Services

North Dakota

- North Dakota Educators Service Cooperative - AEPA

Ohio

- META Solutions - AEPA
- Ohio Mid-Eastern Regional Education Service Agency - AEPA
- Ohio Schools Council - AEPA
- SW Ohio Educational Purchasing Council - AEPA
- Stark County Schools Council - AEPA
- Unified Purchasing Cooperative

Oregon

- Intermountain ESD - AEPA

Pennsylvania

- Keystone Purchasing Network - AEPA

South Carolina

- CA41 Carolina Buy - AEPA
- South Carolina State Contract

South Dakota

- Cooperative Purchasing Connection - AEPA

Texas

- 1GPA - Deer Park ISD
- BuyBoard
- Choice Partners
- Educational Purchasing Cooperative of North Texas - EPCNT
- Regions 1, 3, 5, 7, 9, 11, 14, 15, 18
- Region 6 - EPIC 6
- Region 19 - Allied States Cooperative
- Texas 20 Purchasing Cooperative
- TexBuy - Region 16 - AEPA
- TIPS - Region 8

Utah

- Utah State Contract

Virginia

- Fairfax County Public Schools - AEPA - Statewide

Wisconsin

- CESA Purchasing - AEPA

West Virginia

- Mountain State Educational Services Cooperative - AEPA

Wyoming

- Northeast Wyoming BOCES - AEPA

National Partners



For more information, contact our **Contract & Bid Department** at **800-704-7744** or **Sales@dickblick.com**

BLICK® art materials

PO BOX 1769 GALESBURG IL 61402-1769

CURRENT OCCUPANT OR

Presorted
Bound Printed Matter
U.S. POSTAGE
PAID
DICK BLICK CO.

BLICK STANDS FOR QUALITY

We're committed to the highest quality standards for all art supplies, and our Blick brand of products are no exception! Quality meets value with our wide selection, which makes Blick supplies an excellent choice for artists of all levels, especially art teachers, students, designers, and hobbyists. Plus, our selection of products span a variety of mediums — everything from paint, brushes, frames, canvas and so much more!



Blick Scholastic Brushes
pages 120-122



**Blick White Sulphite
Drawing Paper**
page 200



**Blick Student
Tempera**
page 5



**Blick Studio Artists'
Colored Pencils**
page 323

To order by phone, call toll-free 24 hours a day **800-447-8192**

To order by fax, complete the order form inside and fax to **800-621-8293**

To order online, visit **DickBlick.com** (see page 643 for on-account purchasing)

To order by email, write to us at **PurchaseOrders@dickblick.com**

Customer Service **800-723-2787** Product Information **800-933-2542**

A22



\$6.95

Printed in the USA

