

August 9, 1966

Revised 9-22-66

ENGINEERING MEMO #152

* Chassis No. Added 12-12-66

TO: Memo Distribution

FROM: R. E. Orwig

SUBJECT: 129" W.B. Inner Rear Door Panels (Model A-11E & A-12E)

Due to the increasing volume of 129" W.B. cars, the present method of making inner rear door panels (Salvage from scrap panels or using (2) good A-11-A-12 Panels to make (1) A-11E-A-12E Panel) is no longer economical. Therefore, a new design has been released by Engineering. The new design permits the use of (1) standard panel to be split to make (1) wide panel. The (2) panel halves are then welded to extensions which together make the wide panel.

Following is a list of the parts affected:

- | | | |
|-------------|---|------------------------------|
| 641141 & 2 | Panel Assem-Rear Door Inner-LH & RH | } Present Method (CANCELLED) |
| 641143 & 4 | Panel Assem-Rear Door Inner Front-LH & RH | |
| 641145 & 6 | Panel Assem-Rear Door Inner Rear-LH & RH | |
| 642294 | Plate-Rear Door Inner Welding (1-1/2 x 1-1/4) | |
| 642295 | Plate-Rear Door Inner Welding (5 x 1-1/4) | |
| 643993 & 4 | Panel Assem-Rear Door Inner(With Extensious)- LH & RH | } New Method |
| 643989 & 90 | Panel Assem-Rear Door Inner Frt. Half-LH & RH | |
| 643991 & 2 | Panel Assem-Rear Door Inner Rear Half-LH & RH | |
| 642157 | Extension-Rear Door Inner Upper | |
| 642158 | Extension-Rear Door Inner Lower | |

NOTE: The completed Panel Assemblies are interchangeable. That is: 641141 & 2 is interchangeable with 643993 & 4.
(For Further information Refer to Body B/M Page 44A)

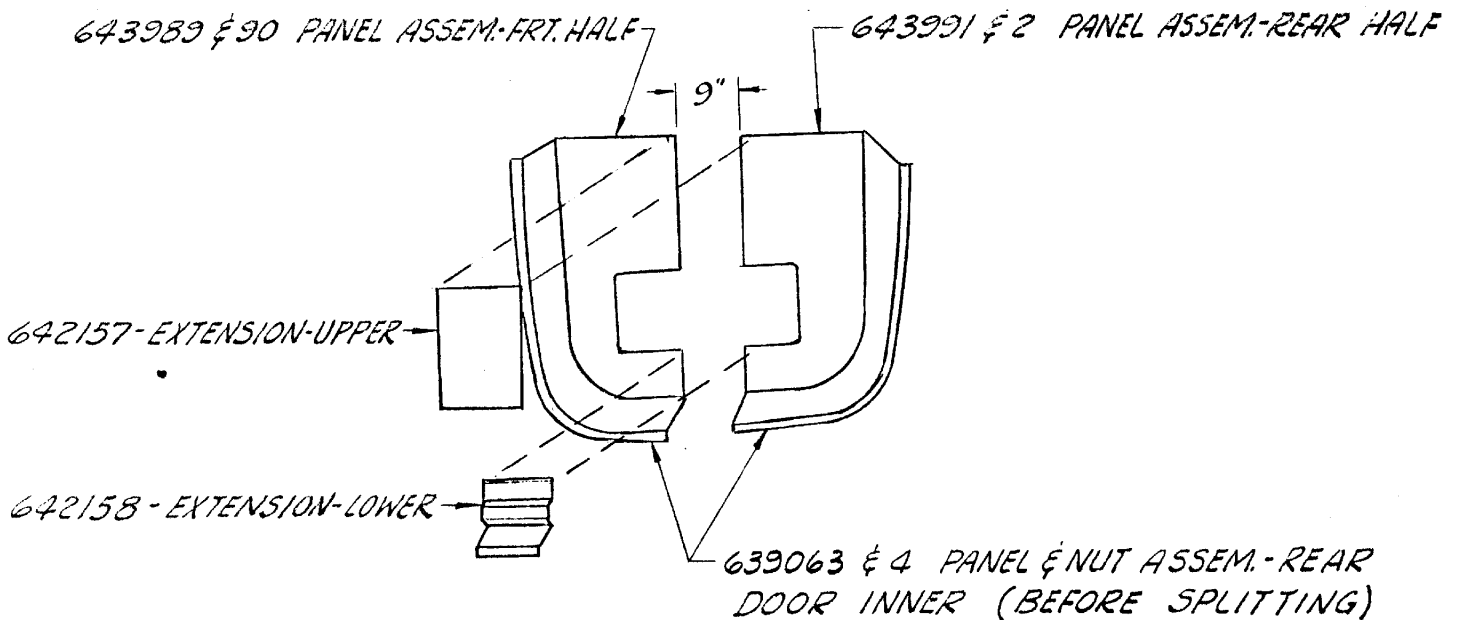

NEW METHOD

* This revision incorporated on Chassis N 4955