

CHECKER MOTORS CORP. KALAMAZOO, MICH.

EFFECTIVE MODEL YEAR 1974

SHEET NO. 250 B-1

DWN.  
CHK.

DATE  
7-31-73

MODEL:  
B-11  
B-11E  
B-12W

GRAPHIC ILLUSTRATION

MOLDING - SIDE DOOR - FENDER - 120"WB + 129"W.E.

APPVD. SUPERSEDES G.I. 250 A-2

- 1. 646665 MOLDING - FRT. FENDER (2)
- 2. 646666 MOLDING - FRT. DOOR SIDE (2)
- 3. 646667 MOLDING - REAR DOOR SIDE (2) 120"WB ONLY.
- 4. 646668 MOLDING - REAR FENDER (2)
- 5. 646669 MOLDING - REAR DOOR SIDE (2) 129"WB ONLY

1. REMOVE DIRT + GREASE WITH DUPONT 3919 S PREP. SOL. IN AREAS THAT MOLDINGS ARE TO BE INSTALLED.
2. LOCATE POSITION OF MOLDING WITH FIXTURE.
3. THE TAPE WHICH PROTECTS THE ADHESIVE SHOULD NOT BE REMOVED UNTIL MOLDING IS READY FOR INSTALL. IN THE CORRECT POSITION.
4. TO COMPLETE OPERATION, A FORCE OF 20 LBS. SHOULD BE APPLIED TWICE WITH A ROLLER OR BLUNT INSTRUMENT TO INSURE PROPER ADHESION TO THE BODY. NO ATTEMPT SHOULD BE MADE TO LIFT THE MOLDING AND THEN STICK IT DOWN AGAIN.
5. VEHICLE SHOULD NOT BE PUT THROUGH AN AUTOMATIC CAR WASH FOR AT LEAST 24 HRS.

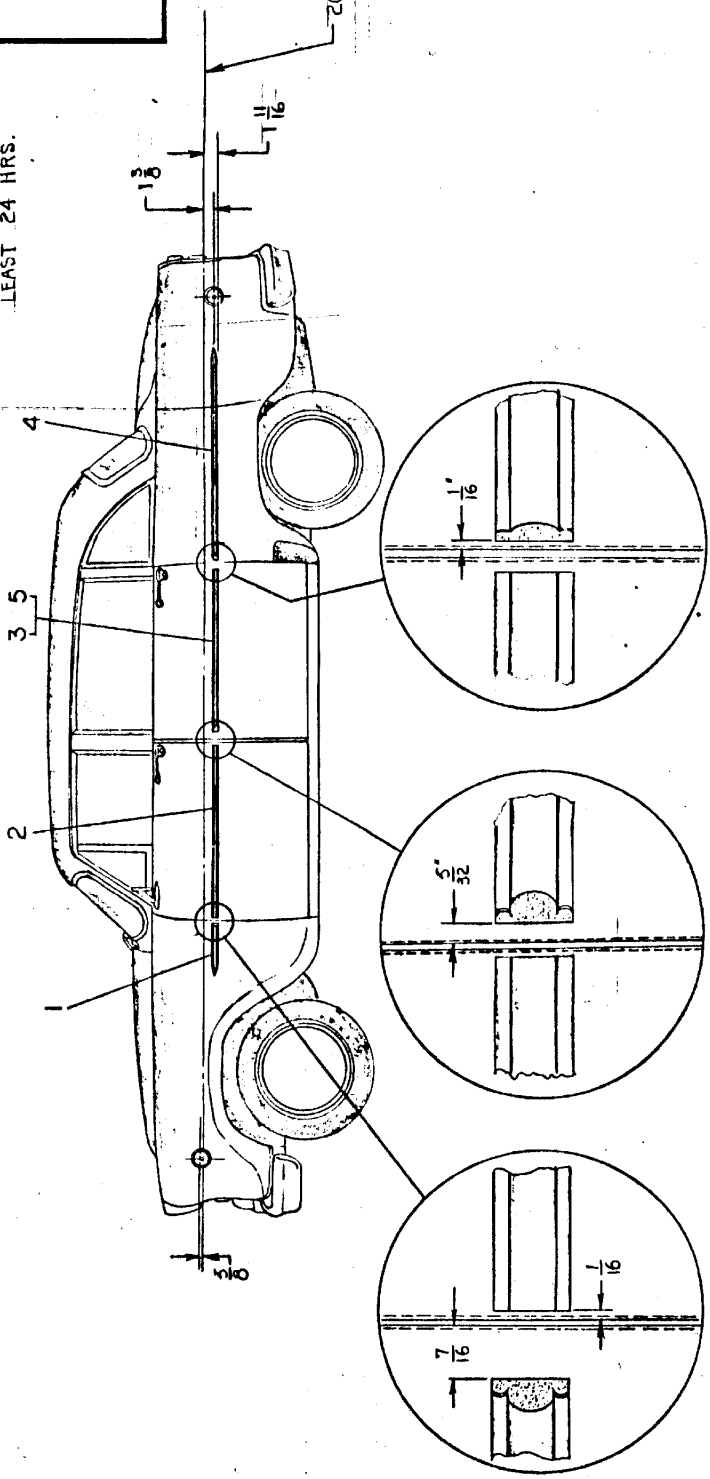

DATE	CHANGES

CHECKER MOTORS CORP., KALAMAZOO, MICH.

EFFECTIVE MODEL YEAR 1974

SHEET NO. 250 B-2

DWN. DATE  
CHK.

APPVD.

MOLDING - SIDE DOOR + FENDER - 189" W.B.

DATE

7-31-73

MODEL: B-12 W8

- 1. 646665 MOLDING - FRT. FENDER (4)
- 2. 646666 MOLDING - FRT. DOOR SIDE (2)
- 3. 646667 MOLDING - REAR DOOR SIDE (6)

1. REMOVE DIRT & GREASE WITH DUFONT 3919 S PREP. SOL. IN AREAS THAT MOLDINGS ARE TO BE INSTALLED.
2. LOCATE POSITION OF MOLDING WITH FIXTURE.
3. THE TAPE WHICH PROTECTS THE ADHESIVE SHOULD NOT BE REMOVED UNTIL MOLDING IS READY FOR INSTALLATION IN THE CORRECT POSITION.
4. TO COMPLETE OPERATION, A FORCE OF 20 LBS. SHOULD BE APPLIED TWICE WITH A ROLLER OR BLUNT INSTRUMENT TO INSURE PROPER ADHESION TO THE BODY. NO ATTEMPT SHOULD BE MADE TO LIFT THE MOLDING AND THEN STICK IT DOWN AGAIN.
5. VEHICLE SHOULD NOT BE PUT THROUGH AN AUTOMATIC CAR WASH FOR AT LEAST 24 HRS.

DATE

CHANGES

