

CHECKER MOTORS CORP. KALAMAZOO, MICH.

EFFECTIVE OCT. 1, 1970

SHEET NO. 250 A-1

DWN. DEKKER
CHK. 4-7-71

APPVD.

GRAPHIC ILLUSTRATION

MOLDING - SIDE

DATE
2-10-71

MODEL:
A-12
A-12E
A-12W

1.	642205	MOLDING - FRT. FENDER	2	4	2	2
2.	640414	MOLDING - FRT. DOOR	2	2	2	4
3.	640731	MOLDING - CENTER	2	2	2	2
4.	640389	MOLDING - REAR DOOR	2	2	2	2
5.	626594	RETAINER ASM.	2	2	2	2
6.	626488	RETAINER ASM.	2	2	2	2
7.	626489	NUT + SEALER ASM.	2	2	2	2
			A	A	A	A
			12	12	12	12
			E	W	W	W

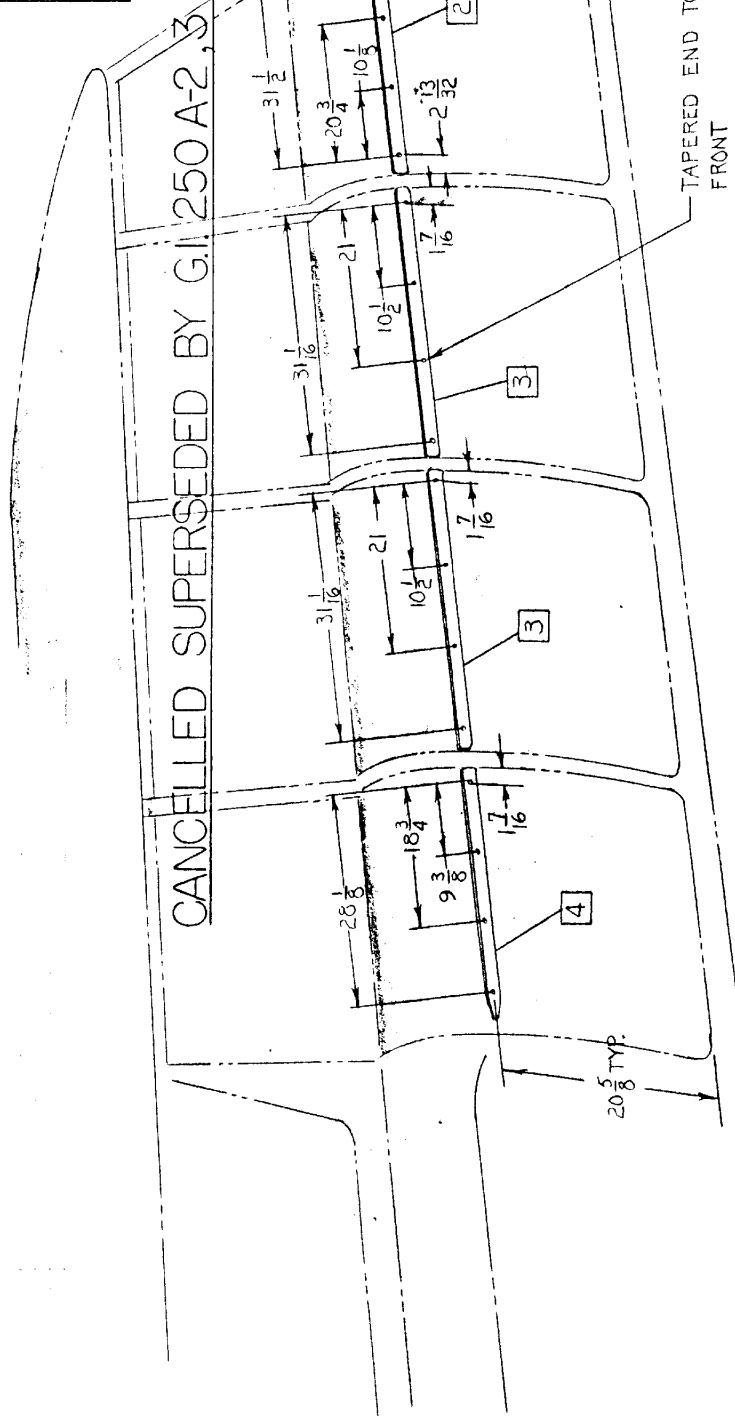
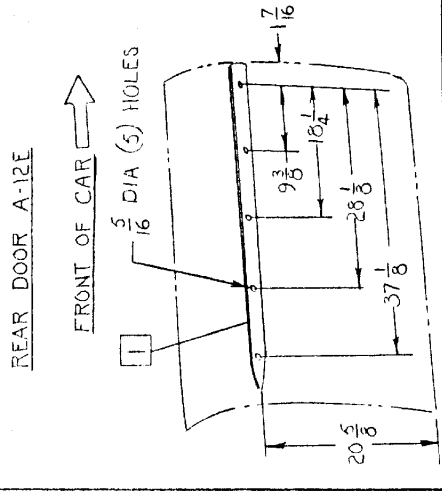

TAPERED END TOWARD FRONT

CHECKER MOTORS CORP. KALAMAZOO, MICH.

MODEL: 8-11 8-11C 8-11E	DATE: 2-8-73	GRAPHIC ILLUSTRATION	DWN. DATE: _____ CHK. _____	SHEET NO. 250 A-2
MOLDING - FRT FENDER (2) MOLDING - FRT. DOOR SIDE (2) MOLDING - REAR DOOR SIDE (2) MOLDING - REAR FENDER (2) MOLDING - REAR DOOR SIDE (2)	MOLDING - SIDE DOOR & FENDER - 120" WB + 1-3" W.E.	APPVD. _____	DATE: _____	CHANGES: _____

1. REMOVE DIRT & GREASE WITH DUPONT 3919 S PREP SOL[®] IN AREAS THAT MOLDINGS ARE TO BE INSTALLED.
2. LOCATE POSITION OF MOLDING WITH FIXTURE.
3. THE TAPE WHICH PROTECTS THE ADHESIVE SHOULD NOT BE REMOVED UNTIL MOLDING IS READY FOR INSTALL. IN THE CORRECT POSITION.
4. TO COMPLETE OPERATION, A FORCE OF 20 LBS. SHOULD BE APPLIED TWICE WITH A ROLLER OR BLUNT INSTRUMENT TO INSURE PROPER ADHESION TO THE BODY. NO ATTEMPT SHOULD BE MADE TO LIFT THE MOLDING AND THEN STICK IT DOWN AGAIN.
5. VEHICLE SHOULD NOT BE PUT THROUGH AN AUTOMATIC CAR WASH FOR AT LEAST 24 HRS.

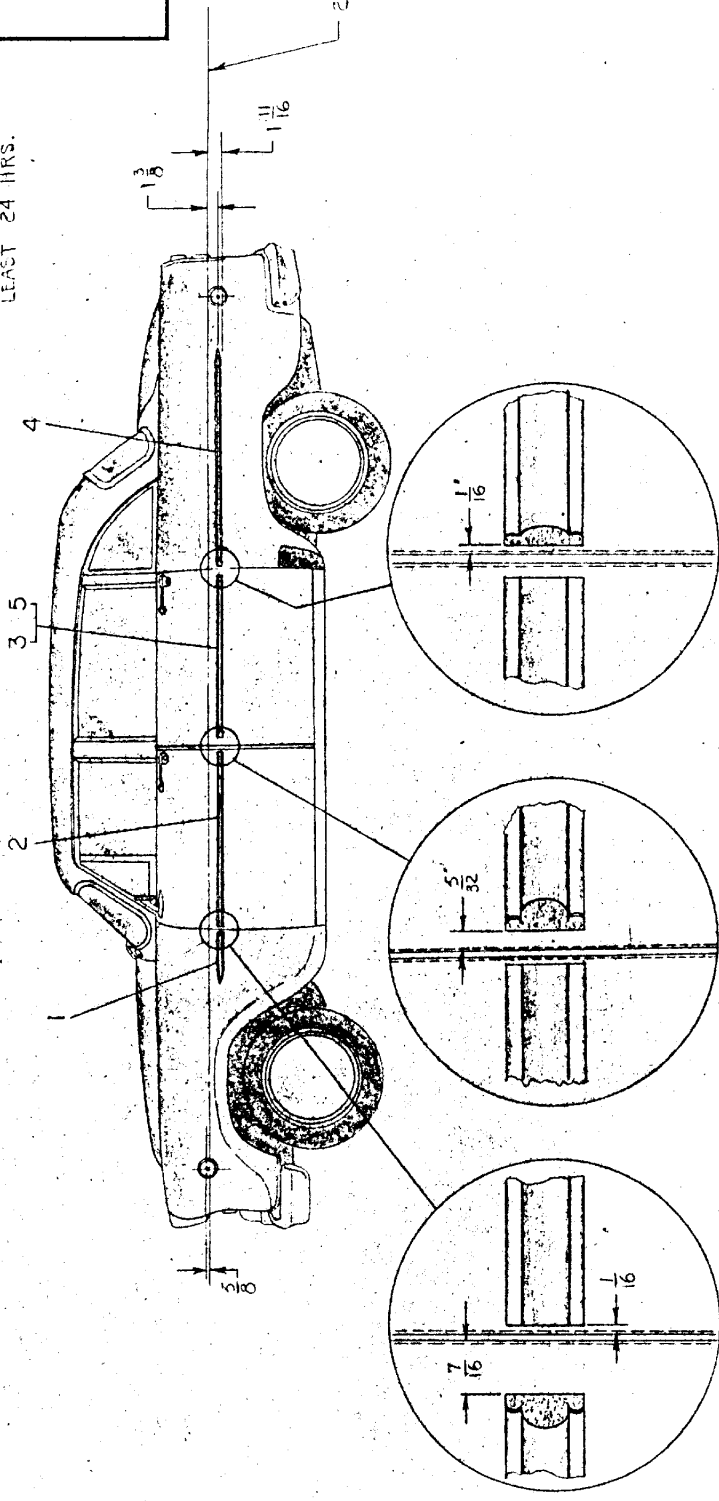

CHECKER MOTORS CORP. KALAMAZOO, MICH.

MODEL:	B-12WS	DATE	2-9-73
DWN. DESK:		SHEET NO.	250 A-3
CHK.		SUPERSEDES G.I. 250 A-1 PER MEMO "334"	
APPVD.		DATE	
		CHANGES	

GRAPHIC ILLUSTRATION

MOLDING - SIDE DOOR + FENDER - 189" W.B.

- 646665 MOLDING - FRT. FENDER (4)
- 646666 MOLDING - FRT. DOOR SIDE (2)
- 646667 MOLDING - REAR DOOR SIDE (6)

- REMOVE DIRT + GREASE WITH DUPONT 3919 S PREP. JOI. IN AREAS THAT MOLDINGS ARE TO BE INSTALLED.
- LOCATE POSITION OF MOLDING WITH FIXTURE.
- THE TAPE WHICH PROTECTS THE ADHESIVE SHOULD NOT BE REMOVED UNTIL MOLDING IS READY FOR INSTALLATION IN THE CORRECT POSITION.
- TO COMPLETE OPERATION, A FORCE OF 20 LBS. SHOULD BE APPLIED TWICE WITH A ROLLER OR BLUNT INSTRUMENT TO INSURE PROPER ADHESION TO THE BODY. NO ATTEMPT SHOULD BE MADE TO LIFT THE MOLDING AND THEN STICK IT DOWN AGAIN.
- VEHICLE SHOULD NOT BE PUT THROUGH AN AUTOMATIC CAR WASH FOR AT LEAST 24 HRS.

