

CHECKER MOTORS CORP., KALAMAZOO, MICH.

680

SHEET NO.

DWG. - DEKker
CHK. Rg 4-8-68
APP'D.

GRAPHIC ILLUSTRATION
HEADLINING - VINYL COATED FABRIC

DATE
4-8-68

MODEL A-12, A-16 BODY

ITEM	PART NO.	DESCRIPTION	A-12	A-16
1	645526	HEADLINING ASSEM.	1	1
2	642654	WIRE #1 - RED	1	1
3	642655	WIRE #2 - ORANGE	1	1
4	642656	WIRE #3 - YELLOW	1	1
5	642657	WIRE #4 - GREEN	1	1
6	642658	WIRE #5 - BLUE	1	2
7	642659	WIRE #6 - PURPLE	1	1
8	642327	WIRE - REAR	1	1
9	626634	CLIP	12	14
10	626456	SCREW W/ WASHER ASSEM.	14	16
11	626616	CLIP	2	2

HEADLINING INSTALL. PROCEDURE FOR SEDAN

1. SCREWS ARE ASSEMBLED TO ROOF WITHOUT CLIPS.
2. WIRE ASSEMBLED TO HEADLINER AS ILLUSTRATED ARE FITTED WITH CLIPS DIRECTLY BEFORE INSTALL.
3. STARTING AT FRONT, HEADLINER ASSEMBLY IS FITTED TO SCREWS, MOVED TO UP-RIGHT POSITION, AND SECURED.
4. MATERIAL IS PULLED AND CLAMPED AT FRONT AND REAR.
5. CEMENTING IS STARTED AT REAR DOOR FRAME. SIMULTANEOUSLY LEFT AND RIGHT, MATERIAL IS STRETCHED AND CLAMPED. SIMILAR FOR FRNT.
6. MATERIAL IS STRETCHED AND CLAMPED WITH CLOTHES PIN AT QUARTER WINDOW.
7. MATERIAL IS CUT TO PERMIT FIT, CEMENTED TO REAR WINDOW TOP, RECLAMPED, AND TRIMMED. WINDSHIELD DONE IN SIMILAR FASHION.
8. X-CUTS AT COURTESY LIGHTS-FOLD BACK AND CEMENT IN PLACE.
9. MATERIAL IS STRETCHED, CEMENTED, RECLAMPED, AND TRIMMED AT QUARTER WINDOW.
10. STEAM IS DIRECTED THROUGH COURTESY LIGHT HOLES INTO ROOF TO REMOVE WRINKLES FROM MATERIAL.

NOTE: MATERIAL IS STRETCHED & FOLDED AT FRONT, CENTER, AND REAR PILLARS WITHOUT CEMENT.

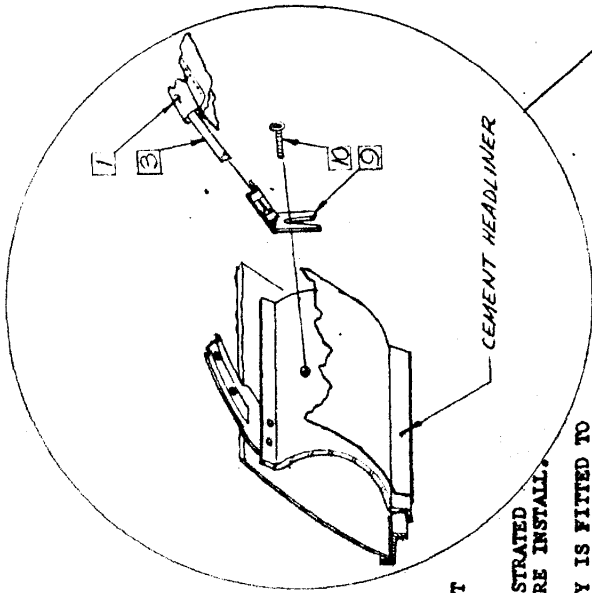

NOTE: HEADLINING ASSEM. FOR A-12 IS 645526

