

Truck Lifts

AL815CC, AL825, AL825CC, AL835
Installation & Owner's Manual

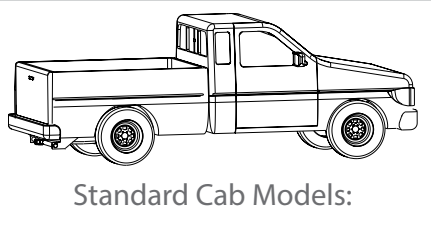

www.harmar.com | 800-833-0478



Standard Cab Models:

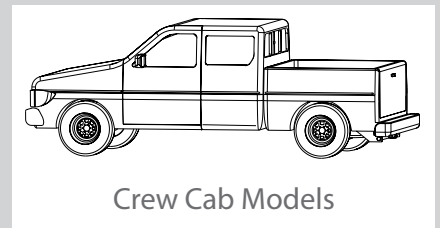

Crew Cab Models

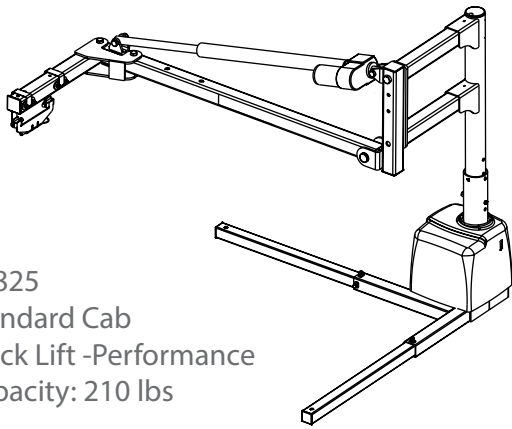

AL825
Standard Cab
Truck Lift - Performance
Capacity: 210 lbs

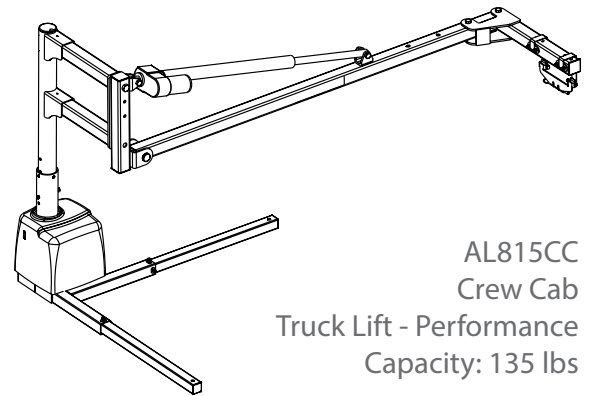

AL815CC
Crew Cab
Truck Lift - Performance
Capacity: 135 lbs

**Available for both driver-side
and passenger-side installation**

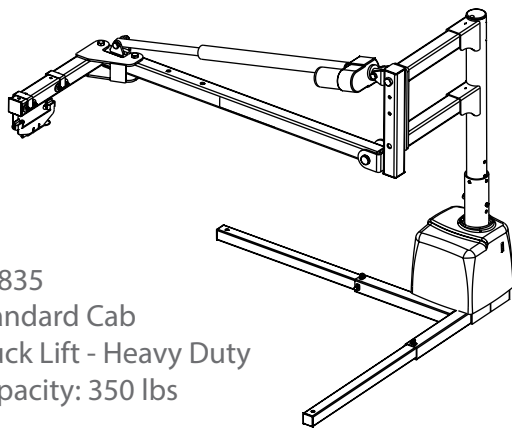

AL835
Standard Cab
Truck Lift - Heavy Duty
Capacity: 350 lbs

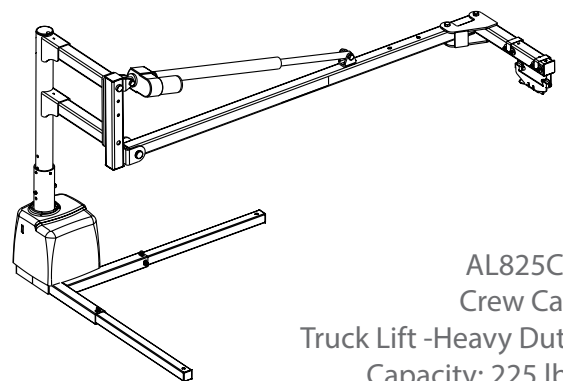

AL825CC
Crew Cab
Truck Lift - Heavy Duty
Capacity: 225 lbs

Read and understand this manual thoroughly before attempting to install or operate the lift. If you have any questions, please contact your Authorized Harmar Dealer or Harmar's Technical Service Department.

P 800-833-0478 | F 866-234-5680 | tech@harmar.com

Dealer Name & Contact Information:

Serial # of Your Lift: _____

Install Date: _____

Table of Contents

SECTION 1: OWNER

OPERATING YOUR LIFT

Docking Devices	3-4
Loading/Securing	5-6
Raising Your Chair / Scooter.....	7-8

SAFETY & MAINTENANCE

9

SECTION 2: INSTALLER

PREPARATION

Tools Required	10
Unpacking the Lift	11
Installation Overview.....	12

INSTALLATION

Wiring the Vehicle.....	13-15
Installing the Base.....	16-19
Post Installation.....	20-21
Installing the Lifting Arm	22-23
Installing the Control Box.....	24-26

TROUBLESHOOTING

29

EXPLODED VIEWS & PARTS LISTS

AL815CC.....	30-31
AL825	32-33
AL825CC.....	34-35
AL835	36-37
Power Base - All	38-39
Electrical.....	40-41

SECTION 3: WARRANTY

WARRANTY

43

Read & Understand this Manual Prior to Installation or Operation. Please read, follow, and fully understand the installation section of this manual before beginning. Knowing the lift's adjustments and the tips on proper installation and operation techniques will save time, energy and avoid possible injury. If you do not understand any portion of installation or operation, please consult our technical service department or authorized mobility dealer.

NOTE: The following symbols indicate areas where you should take special care to avoid danger to individuals or property.



WARNING

Hazardous situation. If not avoided, could result in serious injury to installer or user.



CAUTION

Hazardous situation. If not avoided, could result in serious damage to property.

Docking Devices

The Docking Device is the interface between the lift and the chair or scooter.

Most chairs/ scooters can be lifted either by the center seat post [Figure 3-1] or the four-post seat frame. [Figure 3-2]

Any Harmar Docking Device can be used

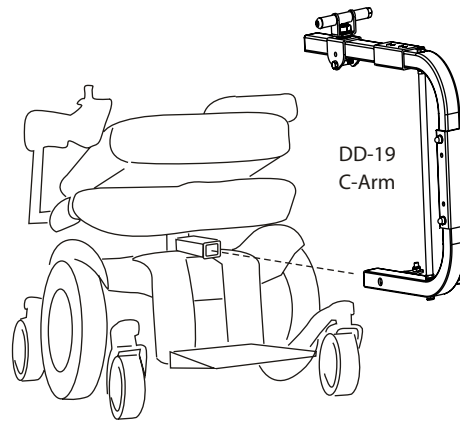

[Figure 3-1]

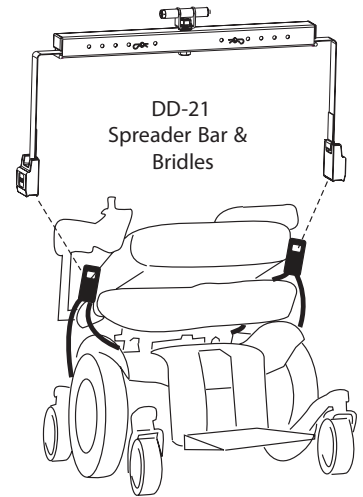

[Figure 3-2]

with the truck lift's double strap hook. Simply remove the bolt as shown. [Figure 3-3]

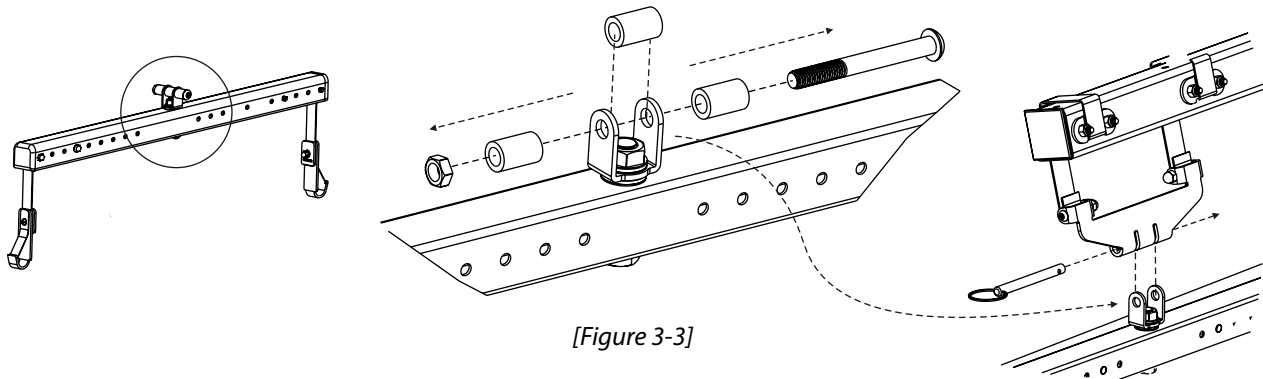

[Figure 3-3]

The Docking Device may also be left permanently attached to the lifting arm on the pick-up truck lift. [Figure 3-4]

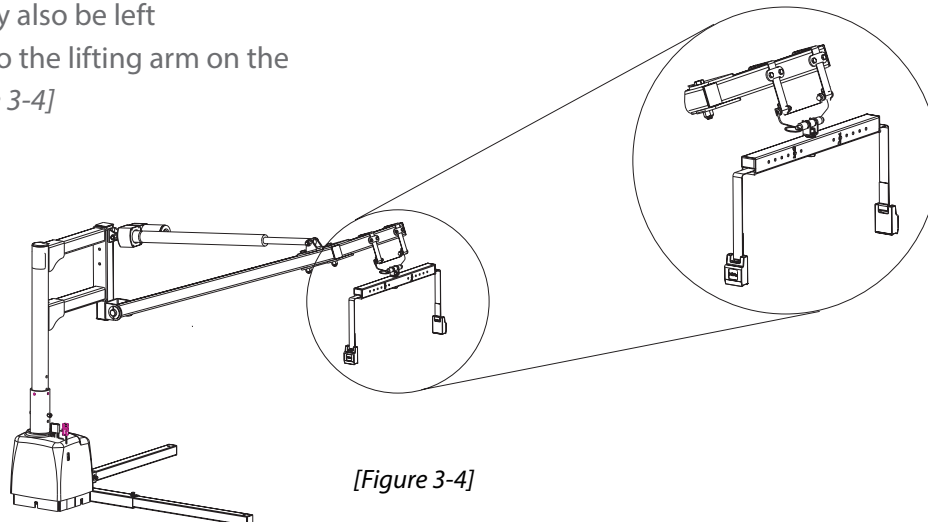

[Figure 3-4]

Types of Docking Devices

The Docking Devices shown are two of the most common and can lift most power chairs and scooters. However, many other devices are available. [Figures 4-1 thru 4-5]

Please consult the instructions provided with your Docking Device or contact our technical service department to find the specific device that will work best for your application.

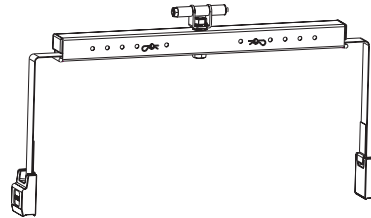

[Figure 4-1]

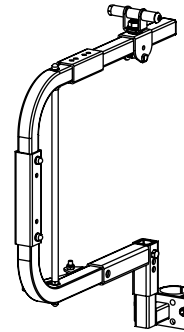

[Figure 4-2]

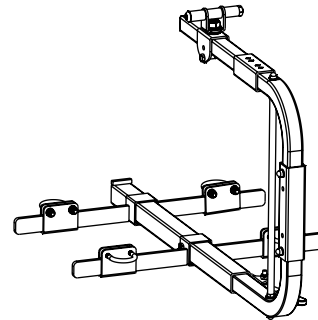

[Figure 4-3]

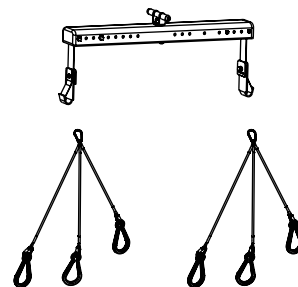

[Figure 4-4]

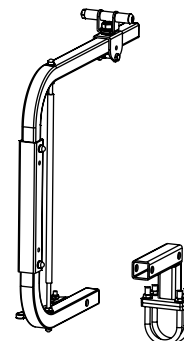

[Figure 4-5]

Loading & Securing Your Chair / Scooter

Position chair / scooter parallel with vehicle. Press the 'UP' button on the remote control to bring the lifting arm above the side wall of the truck bed. *[Figure 5-1]*

Lock the wheels of the chair / scooter (if applicable) and turn the power off.

Press the 'OUT' button on the remote control to move the lifting arm out and around to the parallel position of the truck. *[Figure 5-2]*

Use caution when moving the arm out of the truck bed. Be sure the lifting arm is high enough to clear the truck bed side wall.

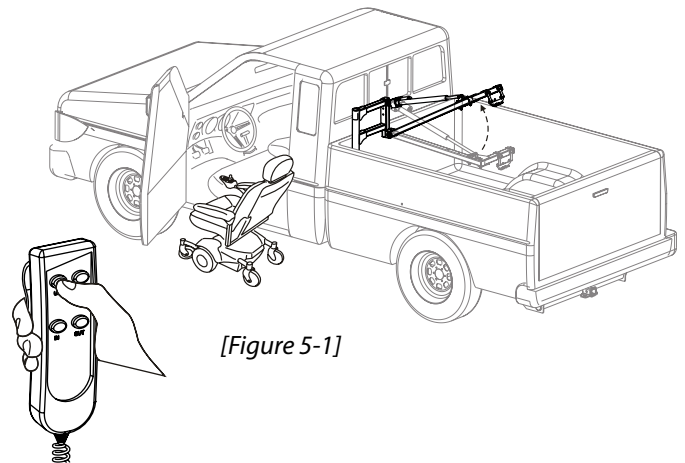

[Figure 5-1]

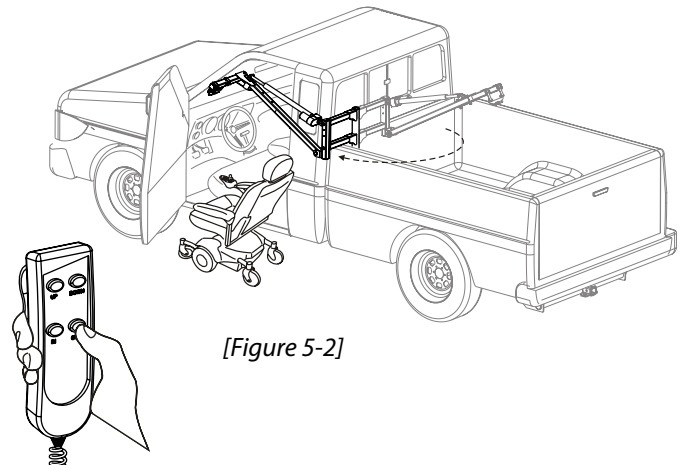

[Figure 5-2]



CAUTION

Arm Must Clear Truck Bed Wall

Before lowering the lift, be sure that the lift has completely rotated and will not collide with the truck.

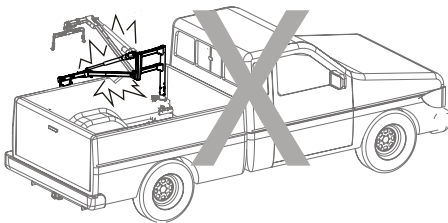

Press the 'DOWN' button on the remote control to lower the lifting arm close enough to the chair or scooter so that you can attach the Docking Device. *[Figure 5-3]*

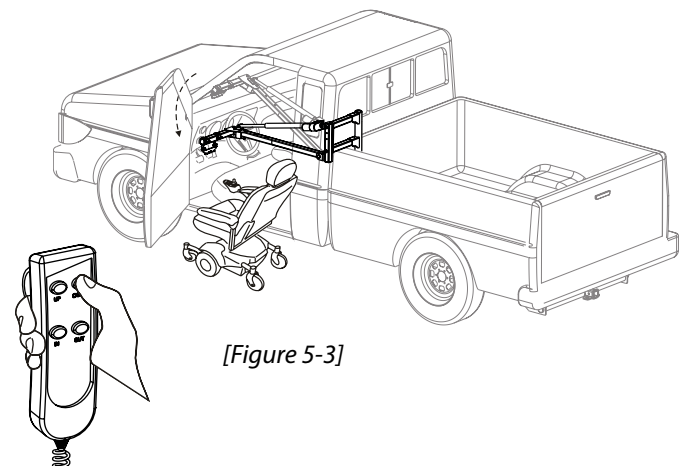

[Figure 5-3]



WARNING

Be sure no people, children or animals are under the payload before lowering

Some applications may require the seat back be folded. [Figure 6-1]

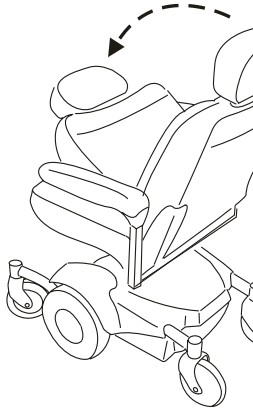

[Figure 6-1]

Attach the Docking Device specific to your application. [Figure 6-2]

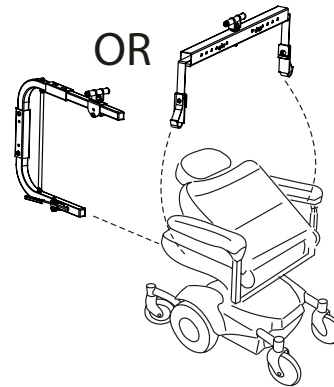

[Figure 6-2]

Pull the quick pin from the lifting hook. Align the docking device and lifting hook as indicated. Replace the quick pin. [Figure 6-3]

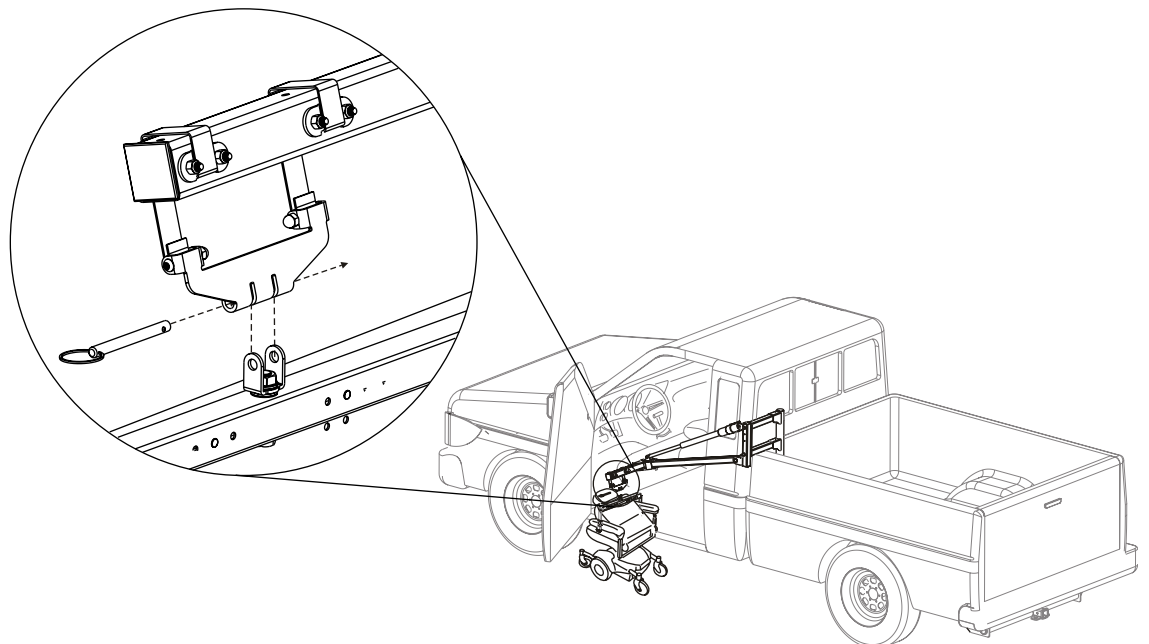

[Figure 6-3]

NOTE: Some applications may leave the Docking device attached to the lifting hook. Please follow the instructions provided by your dealer, or call the technical service department number on the front cover of this manual.

Raising the Chair

Press the 'UP' button on the remote control to raise the chair / scooter. Continue to raise until the bottom of the chair/ scooter will clear the side wall of the truck bed. [Figure 7-1]

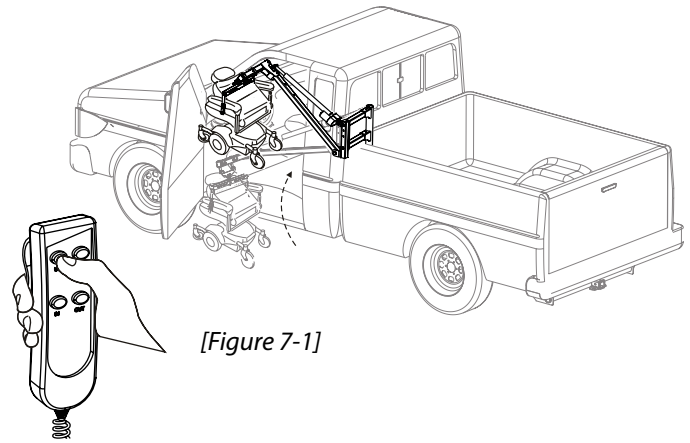

Press the 'IN' button on the hand remote to rotate the lifting arm in and over the truck bed side wall. Use caution while rotating the arm; be sure that the chair/ scooter is high enough so that the wheels clear the top of the truck bed side. [Figure 7-2]

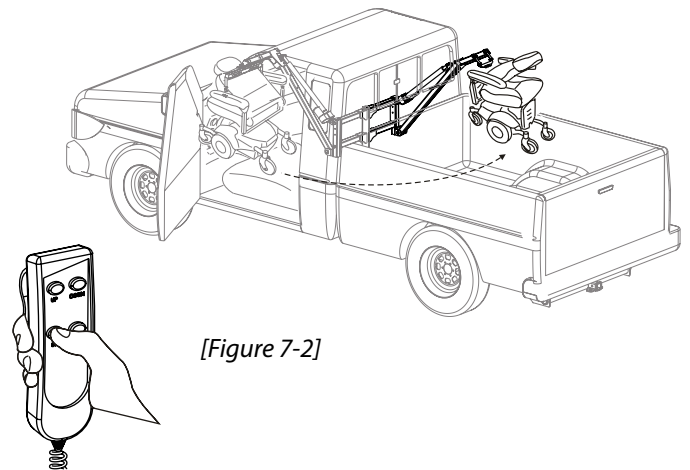

Chair/Scooter on Lifting Arm Must Clear Truck Bed Wall

CAUTION

Before lowering, verify the lift with its chair/scooter has completely rotated and will not collide with the truck.

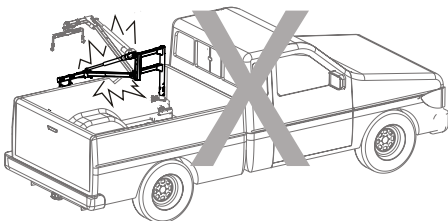

When the chair/scooter reaches the desired position, lower the chair/scooter by pressing the 'DOWN' button on the remote control. [Figure 8-1]

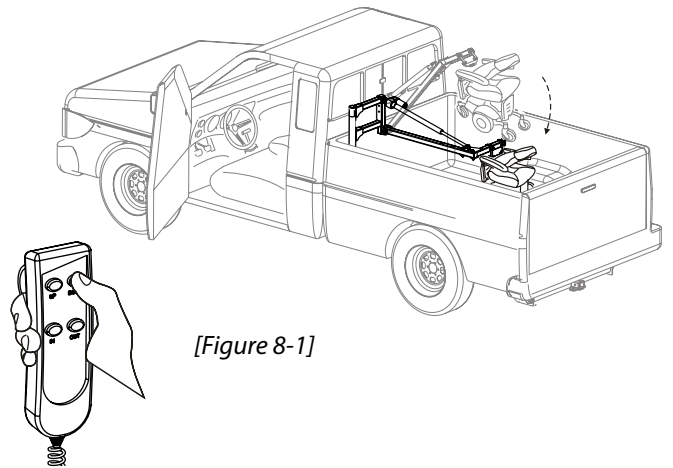

[Figure 8-1]

Stop lowering when about $\frac{3}{4}$ of the chair/scooter's weight is on the floor. The best transportation position for the chair/scooter will be with the lifting arm holding the chair in position, as well as most of the chair/scooter resting on the floor of the truck bed. The lifting straps should remain taut. [Figure 8-2]

To unload the chair, follow the steps in reverse, and reverse the direction of the arrows.

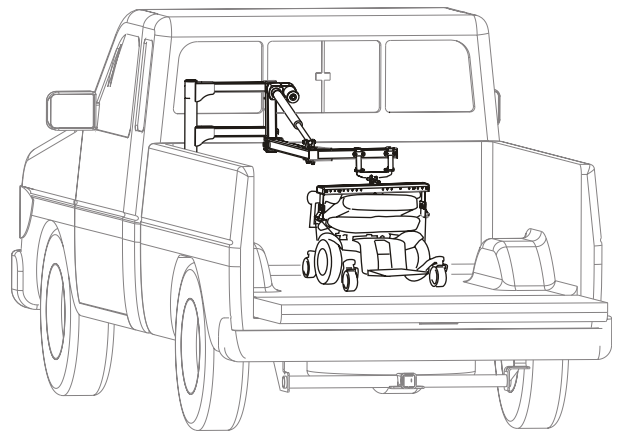

[Figure 8-2]



CAUTION

Do NOT expose Remote Control to rain or snow. If remote control is plugged directly into the lift, remove hand control after each use and store it in the cab.

Safety & Maintenance



CAUTION

Do NOT operate this lift until your dealer/installer has clearly instructed you in its proper operation.

Safety

Your truck lift has been engineered and designed for years of trouble-free use. However, like all mechanic equipment, everyday use may result in some parts becoming damage or worn.

IMPORTANT: Check regularly for any worn, loose or damaged parts on your lift. If you observe any issues, do NOT use the lift. Contact your dealer or installer to make repairs. Failure to act may result in severe injury.

Use your lift only to load and unload the scooters and power chairs for which it is designed. Do NOT add or modify any part of the lift system without first contacting the lift manufacturer. Modifications may void any warranties as well as affect the structural integrity of the lift.



WARNING

Always check the lifting straps before each use for damage or wear.

Make sure the vehicle's parking brake is firmly set before operating the lift.

Ensure that the lifting strap is secure and taut and that it points straight down before lifting the scooter or power chair. Failure to do so could result in the scooter or chair swinging toward the operator of the vehicle.

When using the lift, keep your hands and feet from under the scooter or power chair as it is being loaded and unloaded.

Ensure that the scooter or chair is firmly sitting on the vehicle's floor and is not suspended by the lift. If the scooter or chair is not firmly on the truck bed floor, it may move during transportation and cause damage to the lift, scooter / chair, vehicle, or passengers.



CAUTION

The rotational motor is equipped with a Manual Override in case of a power failure. **To use override, disconnect power before removing cap.** This prevents accidental restoration of power and serious injury.

Maintenance

This Truck Lift is designed to be as trouble-free as possible, but as with any mechanical device, regular maintenance will help ensure that it continues to offer reliable and safe use for years to come.

Schedule a preventative maintenance inspection. Have your dealer inspect the lift at least once a year, including motors, lift frame, wiring harness, and all moving parts.

Check for paint chips and touch up bare metal. Use a good gloss black enamel or lacquer to inhibit rust. You may need to do this more frequently if your lift is subject to salt air, road salt, or debris.

Always check lifting straps before use. If you notice any wear or fraying, do not use the lift. Contact the installer or dealer for repair. Failure to act may cause damage to the vehicle or severe injury.

Do not expose hand control units to the weather. If the cab entry wiring harness is not installed, and the control is connected directly to the lift, remove the hand control each time the lift is used; it should never be exposed to the elements. If your lift did not include the cab entry wiring harness, contact Harmar's technical service department or your dealer / installer to have one installed.

Professional Installation Recommended

NOTE: The following section is designed for the professional installer. We strongly recommend that a certified dealer install the lift and instruct the user on correct operation as well as establish a safety and maintenance schedule.

If you do not understand any portion of installation or operation, please consult our technical service department or authorized mobility dealer. Do not attempt to install or use this lift with any hesitation or question. Serious injury or damage can result if proper procedures are not followed.

Read & Understand this Manual Prior to Installation or Operation.

Having an overall understanding of the lift and proper installation techniques will help you save time, energy, and avoid possible injury.

Tools Required

Installations may vary to some degree, but below are the basic tools to have on hand for an Outside Lift installation.



SOCKET SET
Specifically

15/16"
3/4"
9/16"
7/16"



WRENCH SET
Specifically

15/16"
3/4"
9/16"
7/16"



ALLEN WRENCH
Specifically

1/8"
3/16"
5/16"



WIRE CUTTERS



NEEDLE NOSE
PLIERS

#0,#2 FLAT HEAD
SCREWDRIVER



#2 PHILLIPS HEAD
SCREWDRIVER



MARKING
IMPLEMENT



TAPE MEASURE



ELECTRIC DRILL
w/ 3/8" Drill bit

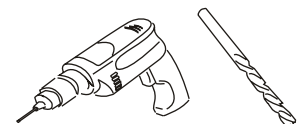

Unpacking The Lift

Check the box contents. Review each part against the packaging checklist to ensure that all parts have been included.

If any parts are missing or damaged, immediately contact the dealer who sold the lift.

Do not attempt to install or use a lift that has missing or damaged parts.

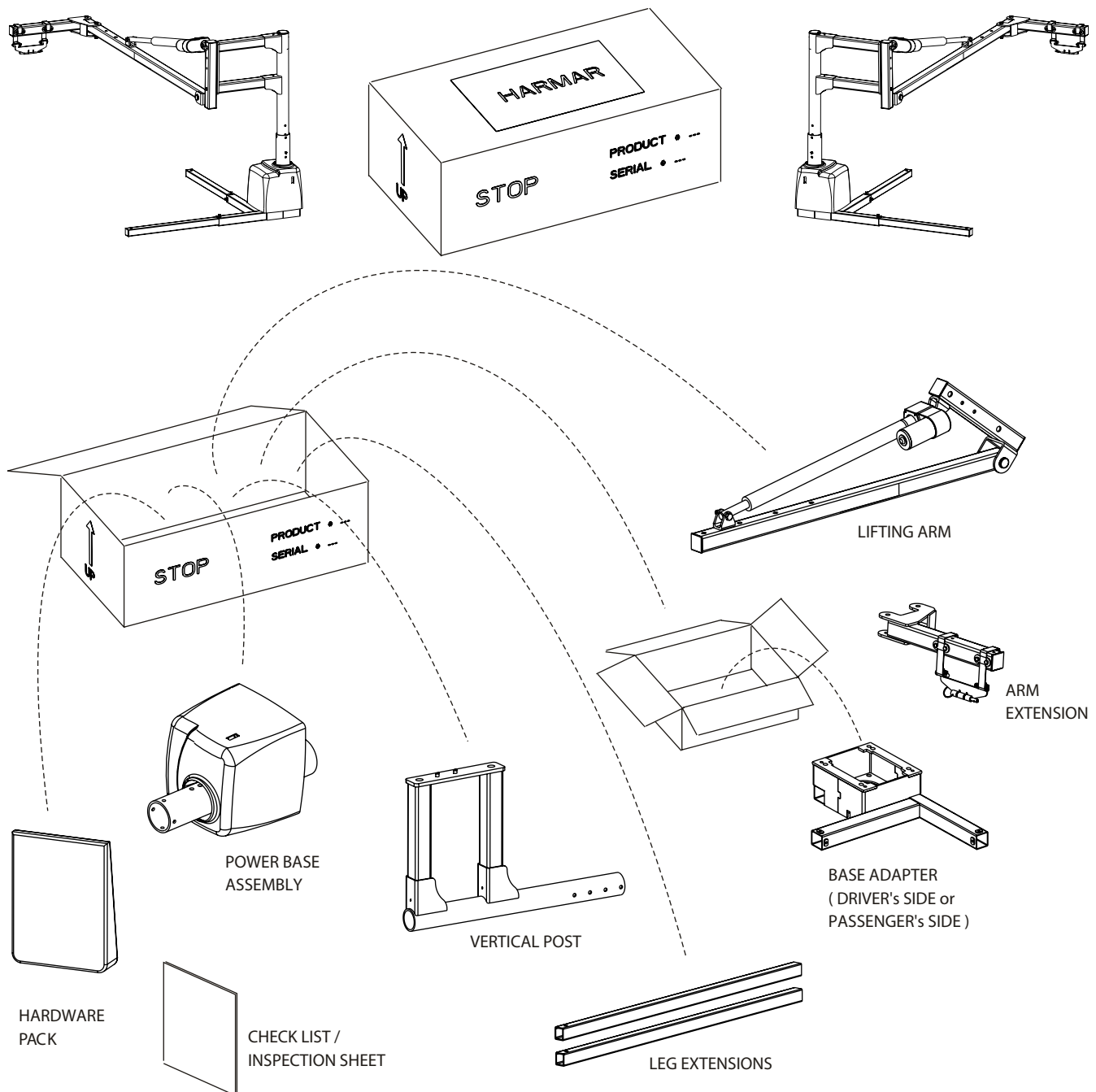

Installation Overview



WARNING

Never attempt to pick up the lift from the box, ground or on/off a vehicle alone.

Two people should work together to place this lift inside a vehicle. If only one person is available, please follow the short disassembly procedure below.



Overview of Recommended Installation Procedure

1. Choose a Location. Place base and leg extensions in the far corner of the truck bed.

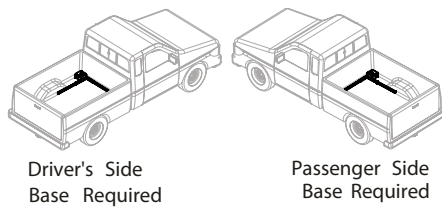

Examine under the truck where three to five holes will need to be drilled. (Number of holes depend on payload)

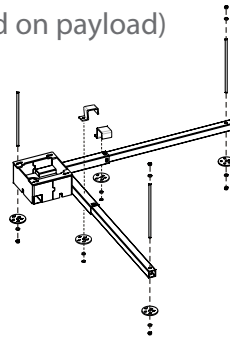

Wherever possible, incorporate the frame rails of the truck. This is a requirement when lifting heavier chairs and scooters.

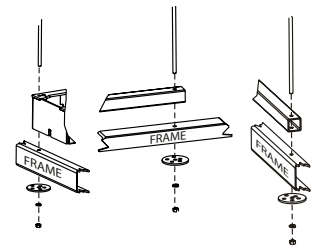

2. Install Vehicle Wiring Harness. Installing the wiring harness first will allow powered movement of the lift, aiding in the installation. [See page 13]

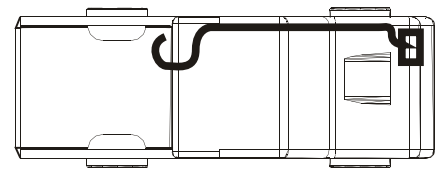
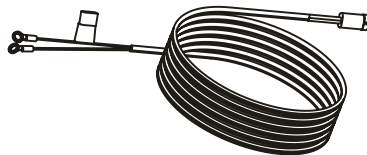
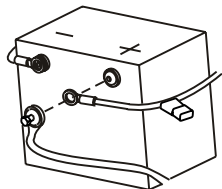

3. Install Lift Components.

Install power base assembly onto base mounted to truck bed. [See pages 19]

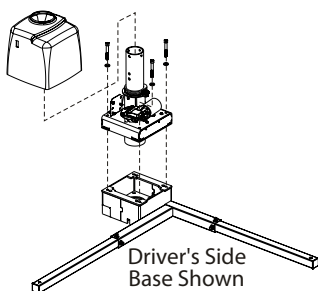

Install vertical post so that bottom horizontal bar just clears truck side wall.

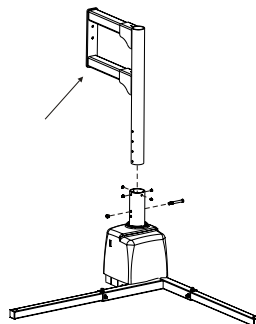

Install lifting arm using bolts provided.

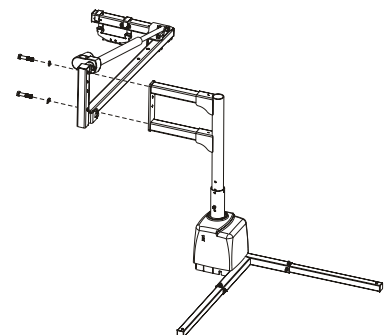

Wiring The Vehicle

IMPROPER WIRING IS THE #1 CAUSE OF PROBLEMS IN THE OPERATION OF A VEHICLE LIFT.

FOLLOW THE WIRING INSTRUCTIONS CAREFULLY

The vehicle wiring harness is located in the hardware pack. The harness is manufactured to comply with SAE J1128 requirements. It is approximately 23 feet long and will accommodate most vehicles.

The wiring harness is unassembled for easier installation. The end connector is included separately from the harness to enable the installer to run the wire under and through the vehicle with the smallest clearance possible

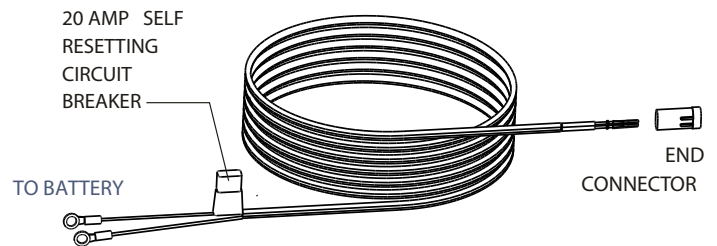

[Figure 13-1]



CAUTION

Do NOT connect the red wire until the very end.

Never attempt to connect the harness to a secondary power source. Always connect both leads directly to the battery.

Unwind the wiring harness and lay it flat.

One end of the harness has 2 covered pins. This is the lift end and goes to the rear cargo area where the lift will mount. [Figure 13-1]

1. Route the wire harness beginning at the battery.

Attach the black wire to the negative terminal on the battery. [Figure 13-2]

Do NOT attach the red wire until the very end of installation.

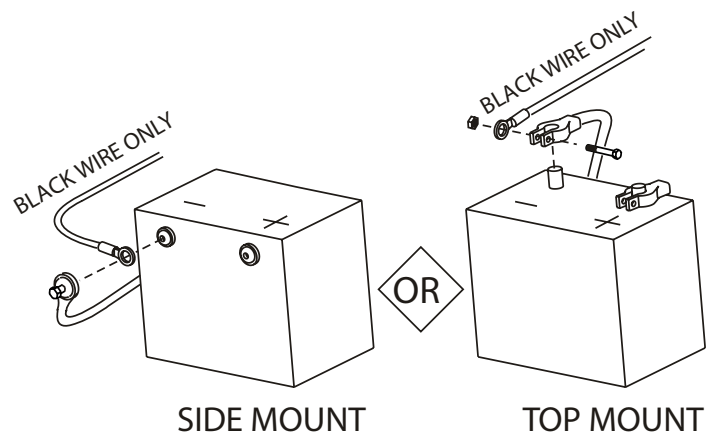

[Figure 13-2]

2. Run the vehicle harness under and, when possible, through the vehicle back to the rear cargo area/trunk.

Run the wire under and through the vehicle whenever possible, gaining entry into the vehicle through the firewall

Do NOT run wiring where it can be snagged by road debris.

Do NOT run wiring near the gas tank.

If you want to run the harness under the vehicle, you will most likely need to drill a hole to get the wire into the truck bed. Use the supplied grommet in the hole to protect the wire.

If the harness is too long for the vehicle, coil the excess wire and secure it to the vehicle frame with the supplied tie wraps. *[Figure 14-1]*

Do NOT cut or shorten the harness.

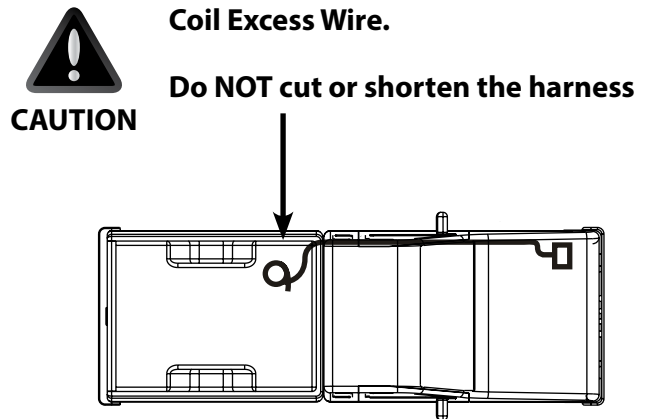

[Figure 14-1]

NOTE: When the installation requires the wiring harness be run on the underside of the vehicle, route the harness away from the exhaust system, brake lines, fuel lines, gas tank, pinch points, and sharp edges.

Locate the harness where it can not be snagged by road debris.

3. When harness is through the vehicle, remove the pin's protective tubing. *[Figure 14-2]*

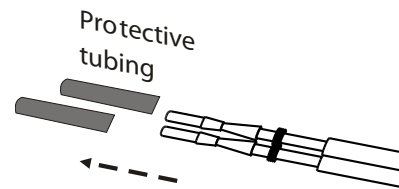

[Figure 14-2]

4. Inspect the pin's retaining flanges.

The flanges may have been deformed while being run through the vehicle. These are critical to secure the pins inside the connector. Adjust as needed.

[Figure 14-3]

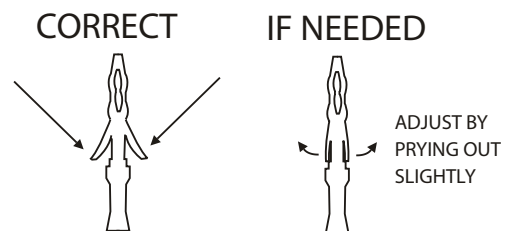

[Figure 14-3]

5. Flip open end connector's hinged retainer. Insert pins as shown. [Figure 15-1]

Verify the wires cannot be pulled out by moderately pulling on the wires. Be sure rubber seals are inside the back of the connector.

Close the hinged retainer.

Plug connector into lift.

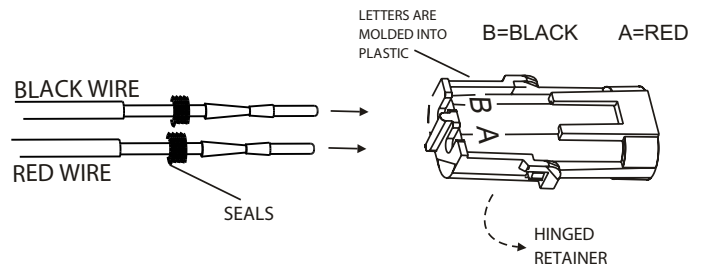

[Figure 15-1]

6. Last, attach red wire to the positive terminal on the battery. [Figure 15-2]

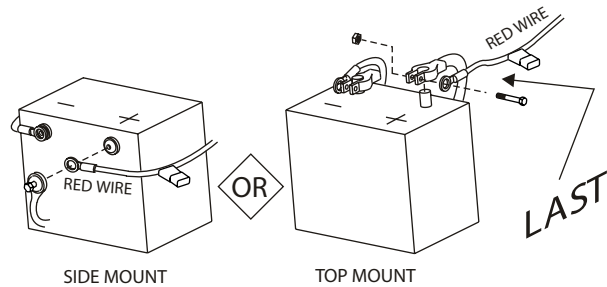

[Figure 15-2]

NOTE: Troubleshooting with a test light or voltage meter may give a false indication.

When you probe for 12 volts, the reading may indicate a connection, even if the connection is not necessarily sufficient. The lift's motor can draw up to 30 amps at some points, requiring all of the available wire to flow proper current. Poor connections are the #1 problem associated with a slow, intermittent, warm, poorly performing motor which will also deteriorate prematurely.

If a single strand of a multi-strand wire is making contact, 12V will appear on a meter or test light, but it will not allow the motor to operate. It is always best to test both current and voltage, or run the motor with known good shop battery or power source when troubleshooting.

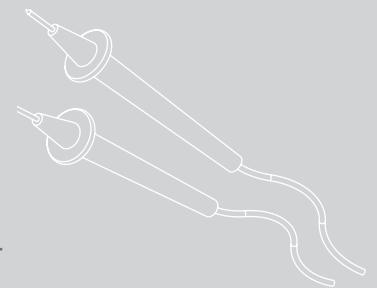

Base Installation

1. Place base in corner of truck bed as shown. Attempt to position as close to the corner as possible. Leave at least 1" around on all sides. [Figure 16-1]

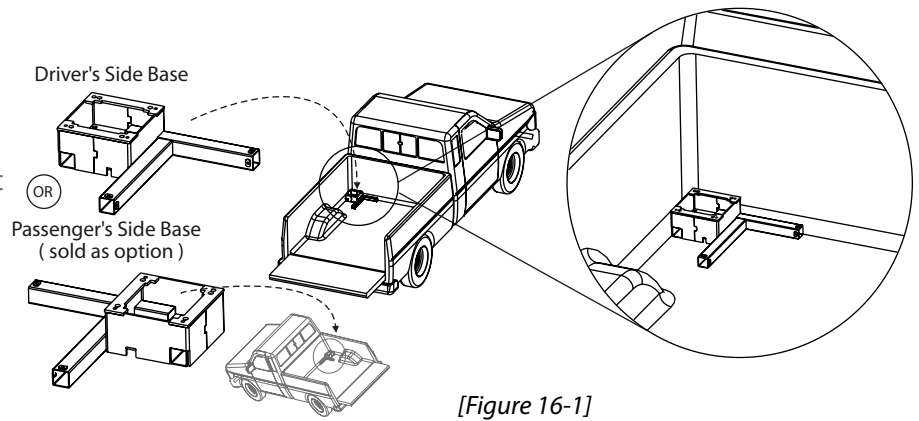

[Figure 16-1]

2. Install leg extensions into base tubes as far as they will go. Set screws can be hand-tightened at this time. [Figure 16-2]

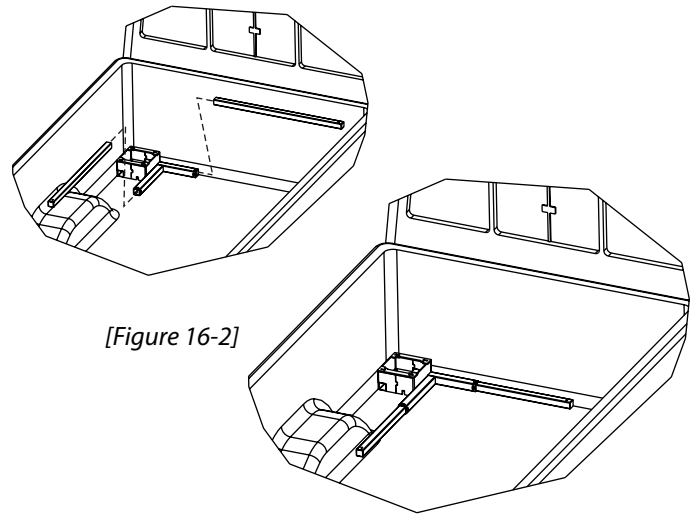

[Figure 16-2]

3. Plan drilling. Three 3/8" holes will need to be drilled through the truck bed and, when possible, through the frame of the truck in the down locations. [Figure 16-3]

Two more 3/8" holes will need to be drilled through the truck bed if frame is not captured, bed material is too thin, and/or application is very heavy.

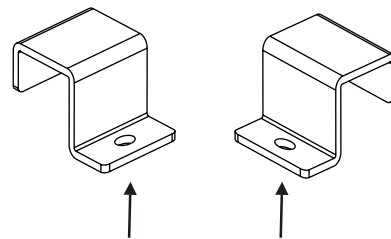

[Figure 16-3]

NOTE: If the application will be lifting a heavier chair / scooter, drilling and bolting through the frame becomes mandatory. [Figure 17-1] Please consult the technical service department listed on the front cover of this manual if you are unsure whether this is required.



USE EXTREME CAUTION

Avoid Gas Tank, Fuel / Brake / Electrical Lines

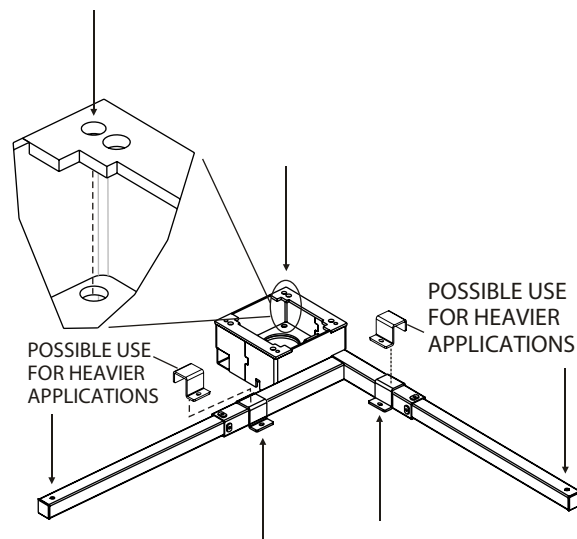

[Figure 17-1]

Recommended practice before drilling.

With base in position, take a tape measure and estimate distance in both directions from an exterior reference point (Ex: outside body panel) to all three potential bolt holes.

Climb under vehicle and recreate measurements of the three bolt holes.

Examine areas for framing, bracing, or other closely available thickened structure to mount the lift through.

Adjust position of base and leg extensions to capture as much frame as possible while avoiding vehicle's gas tank, spare tire, suspension components, etc.

When you are confident of the position for all three holes, climb into the truck bed. Using the base as a template, mark the three locations with a pencil. Remove base.

Drill down through truck bed with pilot holes in the marked locations.

Climb under truck and inspect location of pilot holes. Once again, be sure the larger hole will avoid vehicle's gas tank, spare tire, suspension components, etc.

Finish drilling all three holes with a 3/8" or slightly larger drill bit.

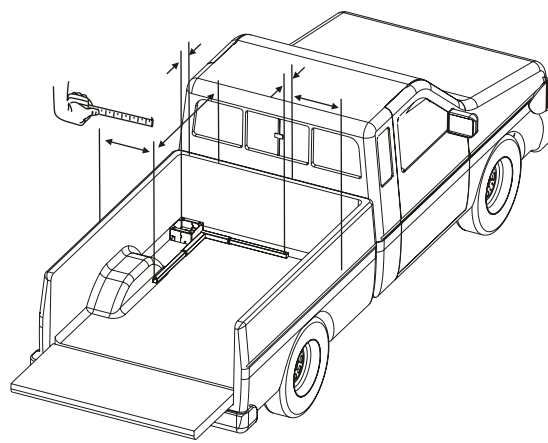

[Figure 17-2]

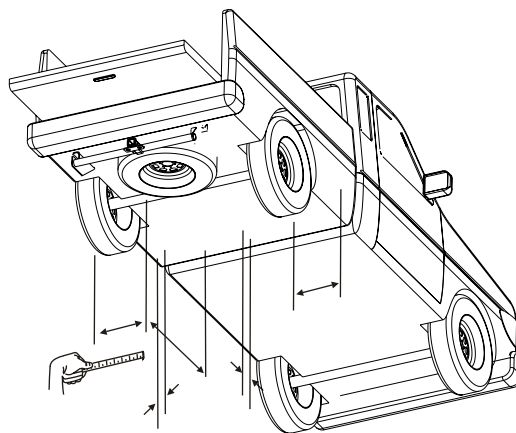

[Figure 17-3]

Base Installation (con't)

4. Secure base to the truck bed using hardware indicated below. Tighten all hardware (except temporary hex nut) to approx. 30 ft. lbs.

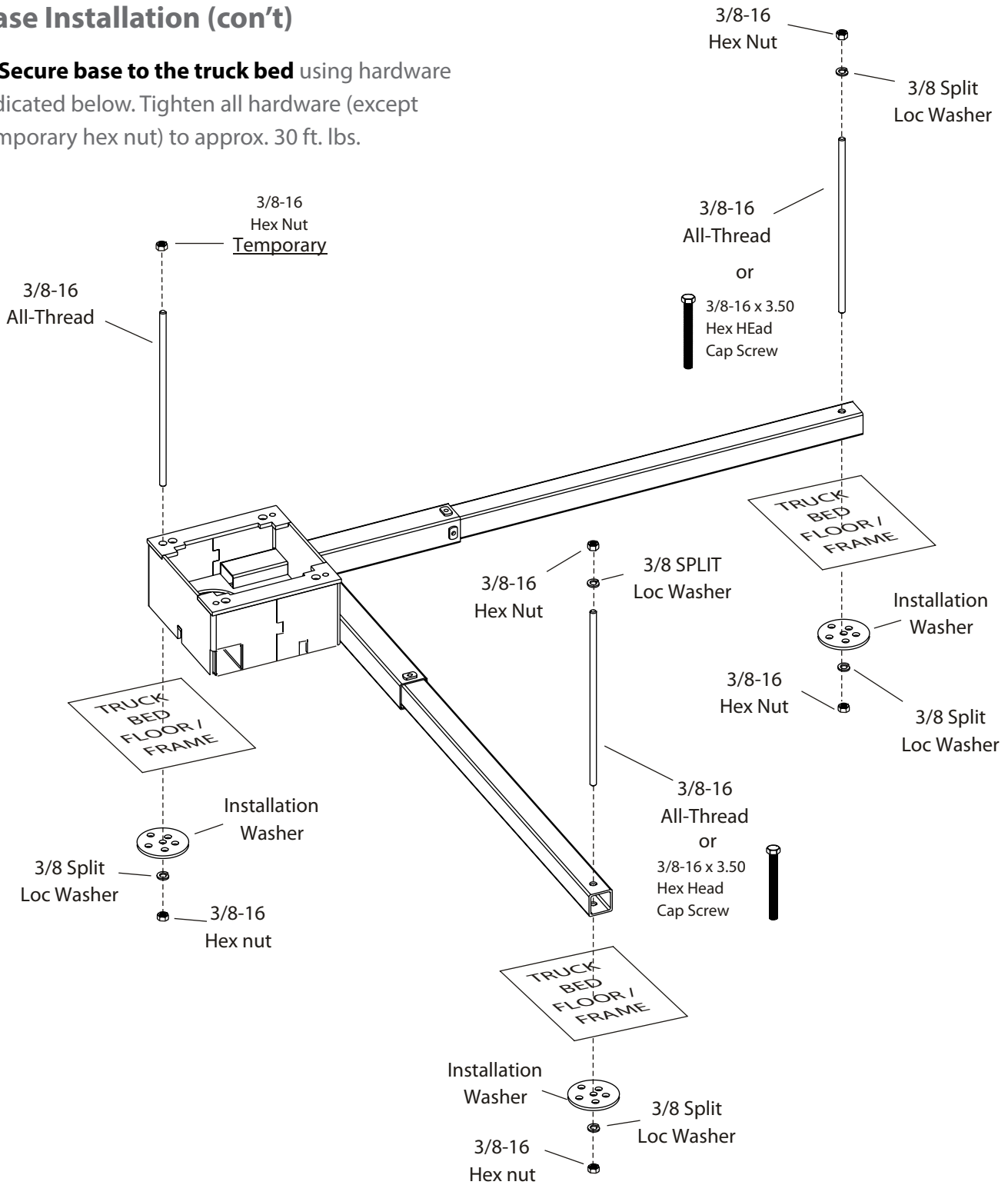

Figure 18-1]

Wherever possible incorporate the frame rails of the truck. This is a requirement when lifting heavier chairs and scooters. [Figure 19-1]

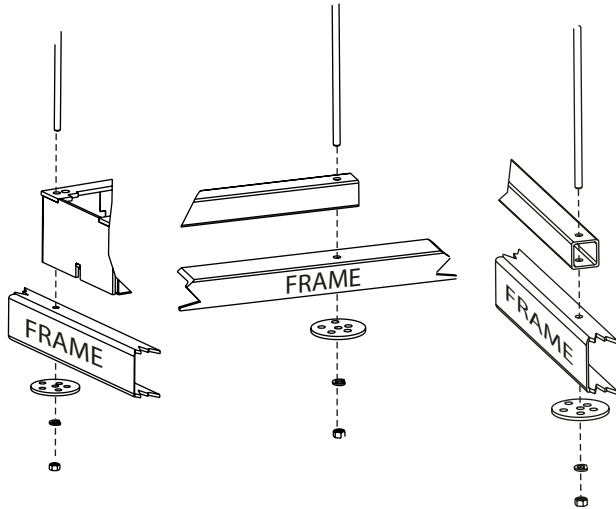

Figure 19-1

As a last resort, if the truck frame cannot be used in the mounting, adding these two anchor brackets will help stabilize the lift and help prevent the truck bed from tearing. [Figure 19-2]

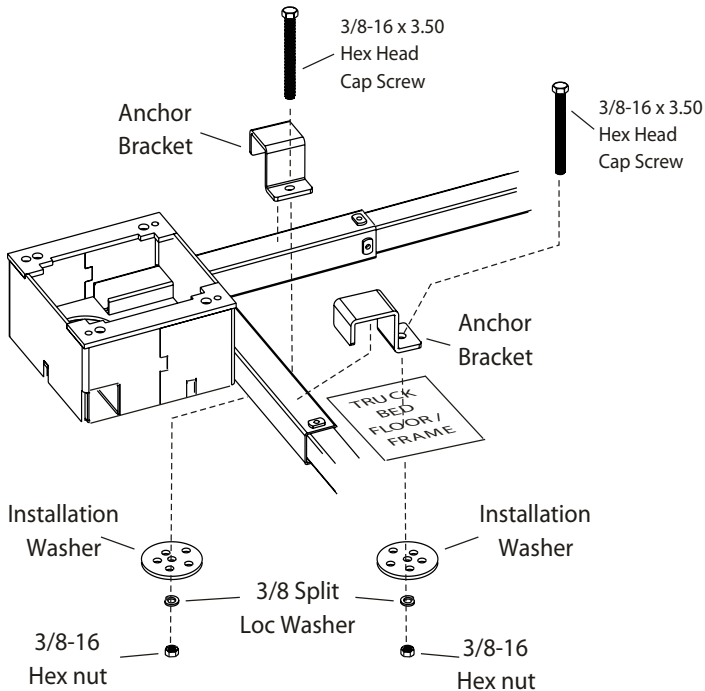

Figure 19-2

5. Remove temporary hex nut. Attach Power Base Assembly as shown. Tighten bolts to approx. 30 ft. lbs.

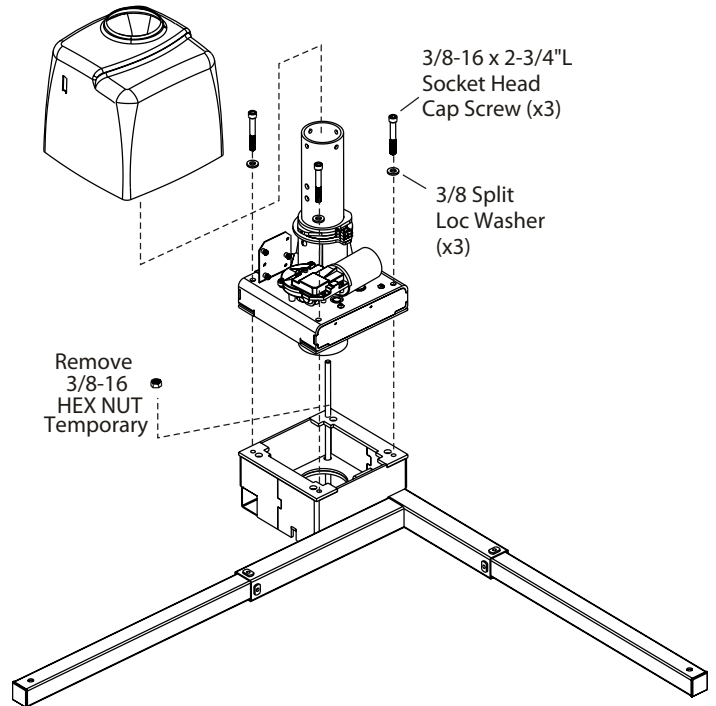

Figure 19-3

6. Finish assembly with one more loc washer and hex nut in corner as shown. Tighten to approx. 30 ft. lbs. Cut off excess all thread if desired.

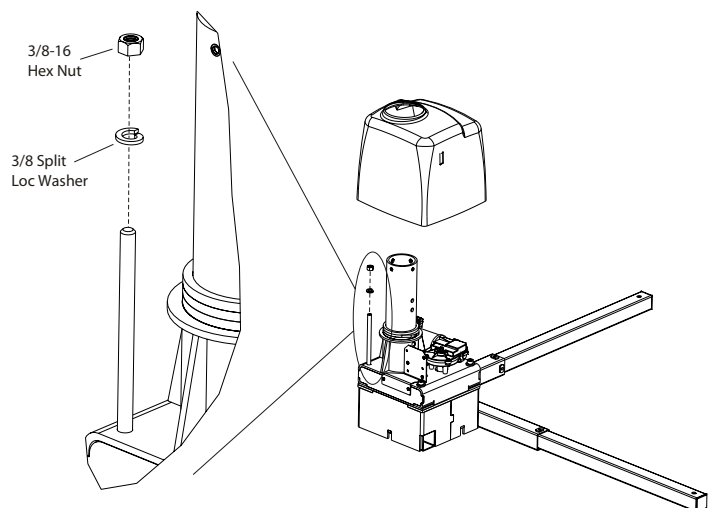

Figure 19-4

Post Installation

The average installation will require approximately 180 degrees of rotation as shown. [Figures 20-1 & 20-2]

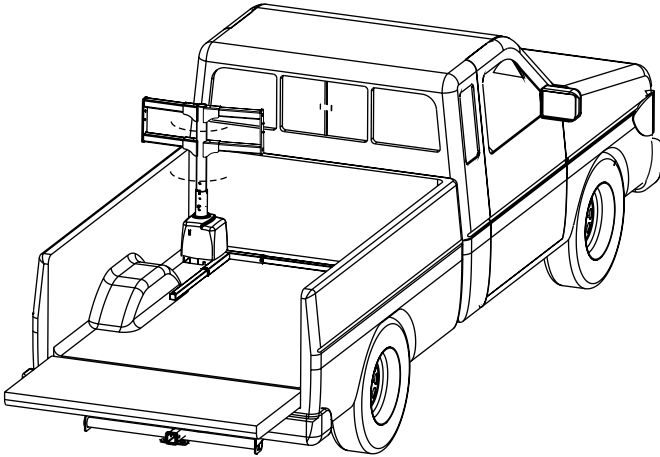

Figure 20-1

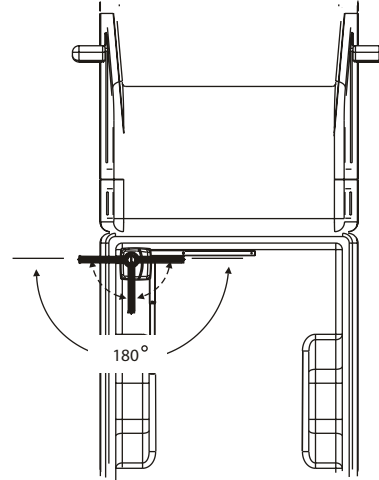

Figure 20-2

1. Loosen set screws and insert vertical post.
[Figure 20-3]

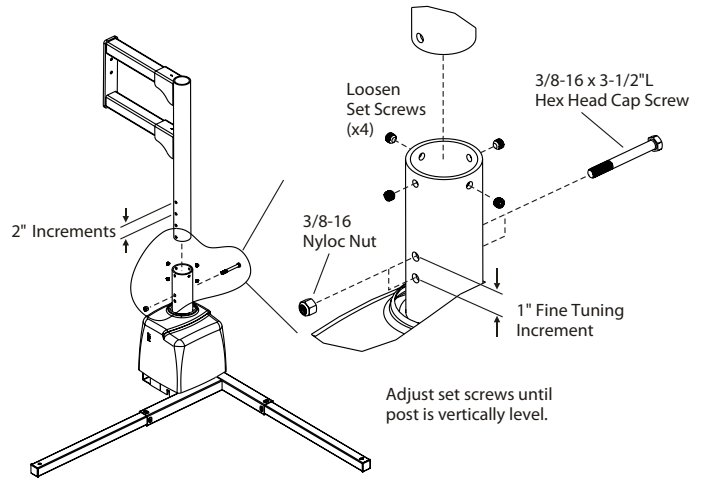

Figure 20-3

2. Plug in the hand control and turn the lift 'On.'
Press the 'In /Out' button to test the post height.
[Figure 20-4]

Ideally, the post's horizontal tubing should just clear the truck's bed side wall. Adjust height as required.

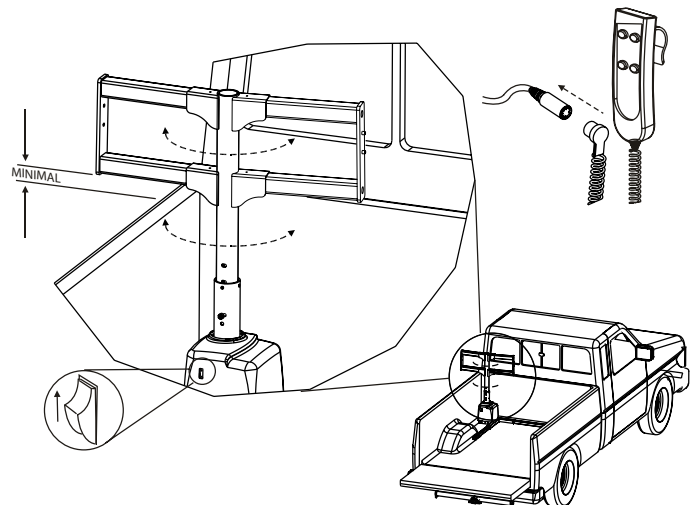

Figure 20-4

3. The amount of allowable rotation is determined by the cams as indicated. [Figure 21-1]. Loosen set screw and rotate as required.

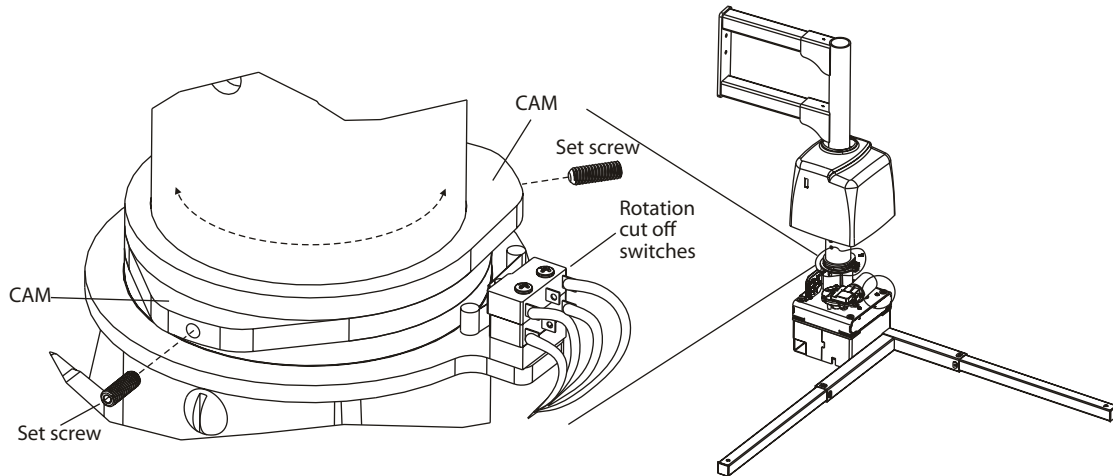

Figure 21-1

4. Reversing Rotation: If installing the lift on the passenger side, or the post rotates in the wrong direction, simply reverse the wires at the rotational motor. [Figure 21-2] You may also need to flip the rotation cut-off switches to properly stop the motor. [Figure 21-3]

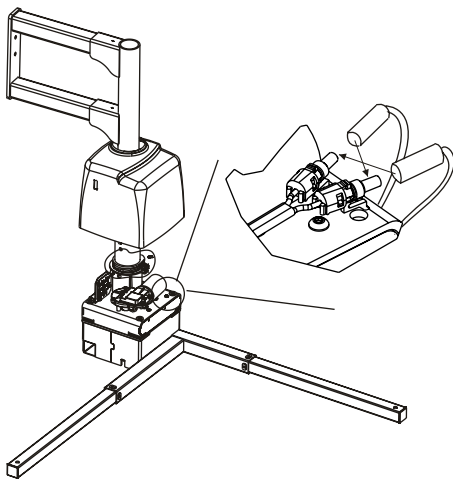

Figure 21-2

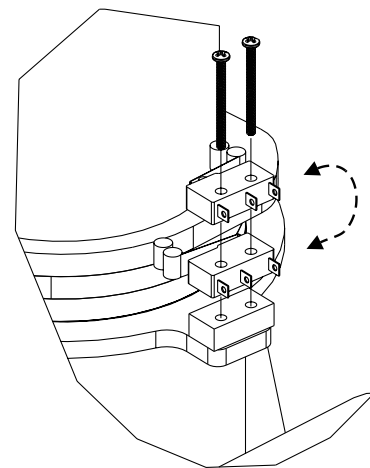

Figure 21-3

Installing The Arms

1. Rotate the vertical post outside the truck. *[Figure 22-1]*

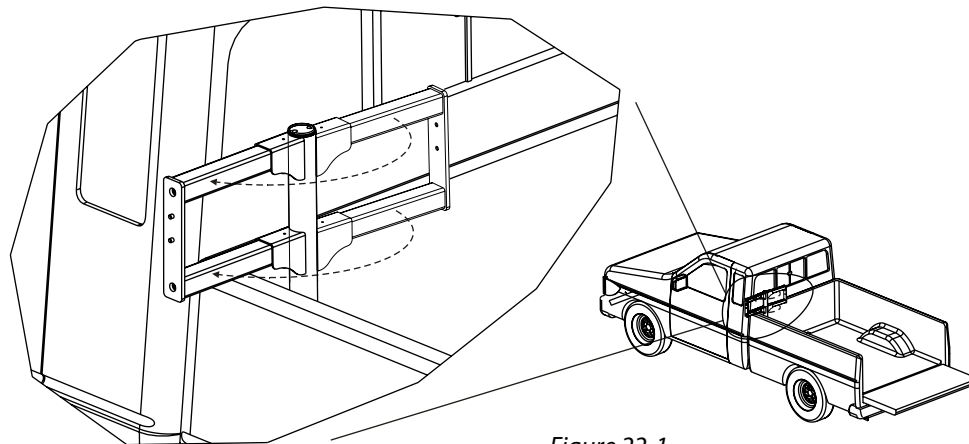

Figure 22-1

2. Attach lifting Arm as indicated. Tighten bolts to at least 100 ft. lbs. *[Figure 22-2]*

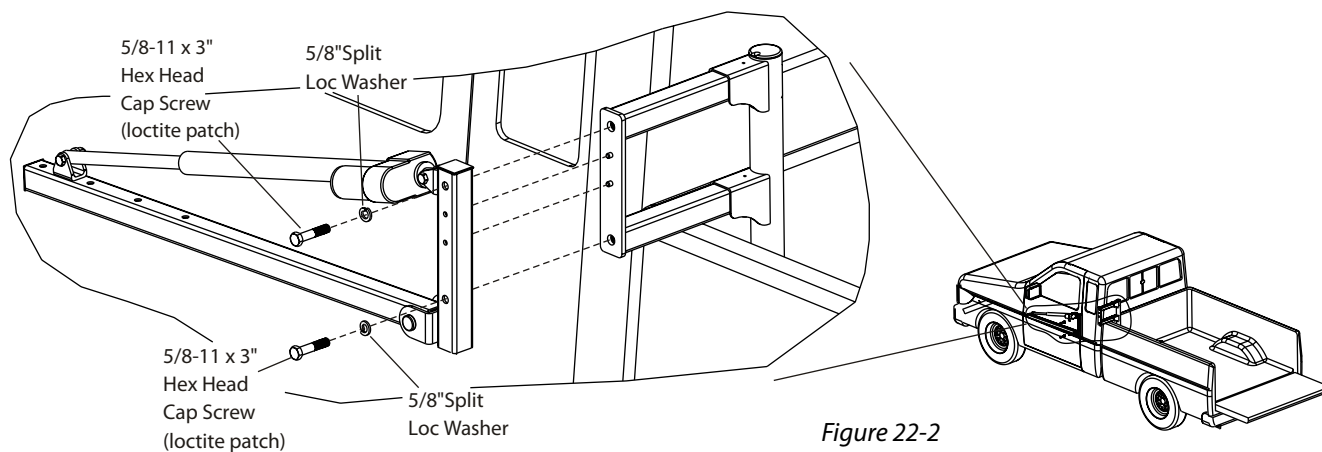

Figure 22-2

3. Plug in actuator at this time. *[Figure 22-3]*

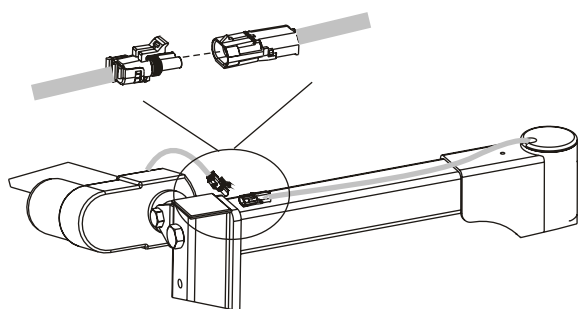

Figure 22-3

4. Attach Strap Arm in the appropriate set of holes based on the amount of reach required. [Figure 23-1]

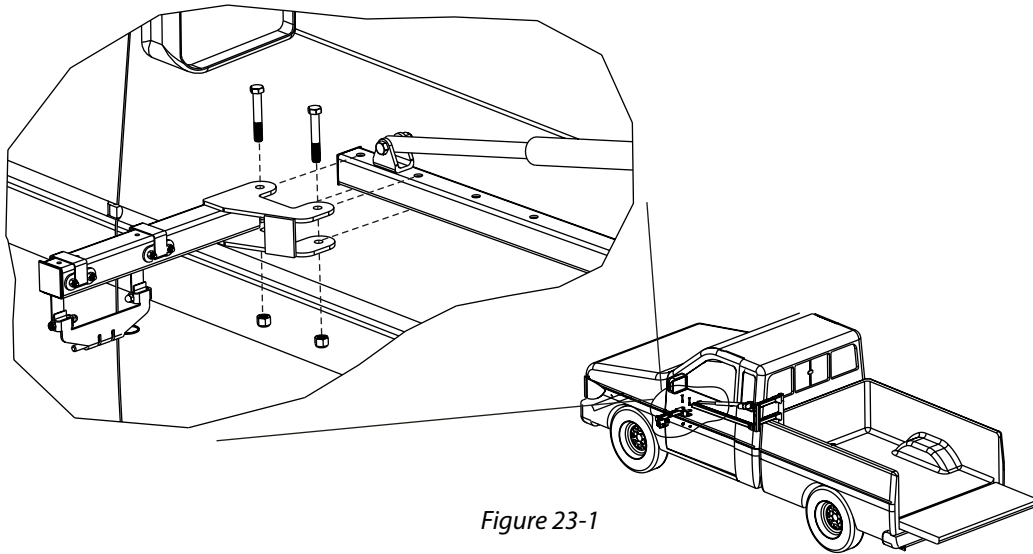

Figure 23-1

Arm may be flipped or positioned farther back for shorter reach. Straps should be reversed if flipped. [Figure 23-2]

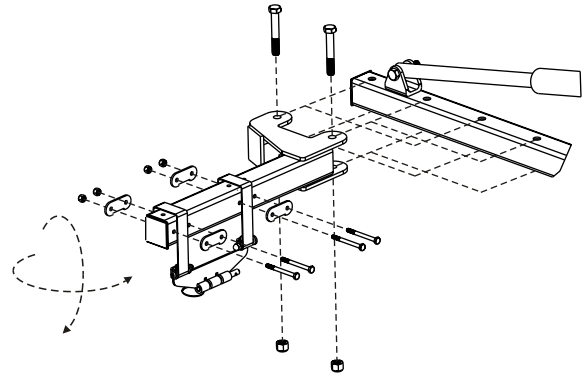
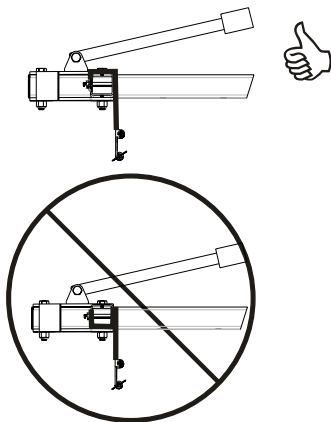

Figure 23-2



WARNING

Never wrap strap over edge of strap keeper.



NOTE: Bolt must always be inserted through the top. If inserted from the bottom, the nut will interfere with the activator.

Installing The Control Box

A small black switch with 10 feet of coiled wire is included in the Truck Lift hardware kit. This allows the hand control to extend into the cab of the truck. One end of the coiled wire has no connector, allowing entry from the lift in the truck bed to the truck cab using the smallest opening possible.

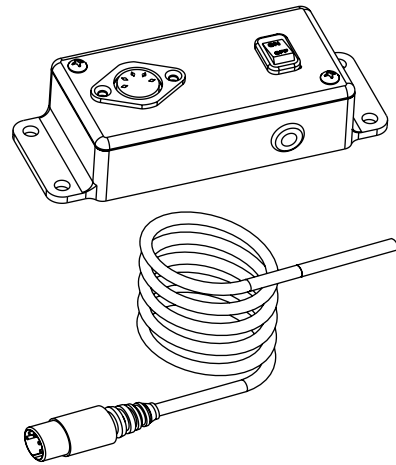

NOTE: Work with the lift's end-user to determine the most convenient location for the control box mounting. If the customer does not want holes drilled into their truck's console, the box may be secured with Velcro, cable ties, or simply tucked into a safe location. The screws provided are self-drilling and threaded for today's internal dashboards, consoles, and various trim. Choose the location wisely.

1. Plug the connector end of the wire to the lift.

Look for access ports between the cab and bed wall where the wire bundle can be passed through. If no such ports exist, a 1/4" hole will need to be drilled either in the floor or the cab wall to pass the wire into the cab area.

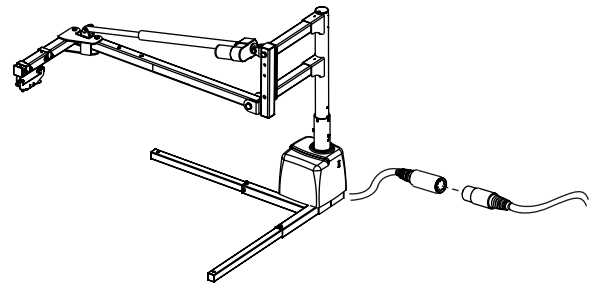

2. Feed the wire under and, whenever possible, through the vehicle, securing the wire bundle with tie wraps along the way. Always be sure to route the wire in areas where it will not be subject to road debris, sharp vehicle parts, exhaust heat, or other hazards.

When you've determined the right location, bring the wire bundle end to the approximate area where you will mount the enclosure.

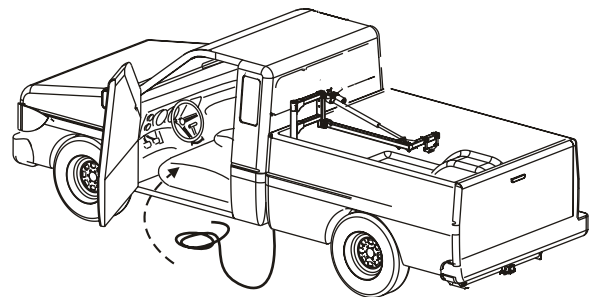

3. Open the enclosure and insert the wires through the grommet. Pull enough wire through to be able to manipulate the ends. (Save screws to seal the enclosure at the end.) [Figure 25-1]

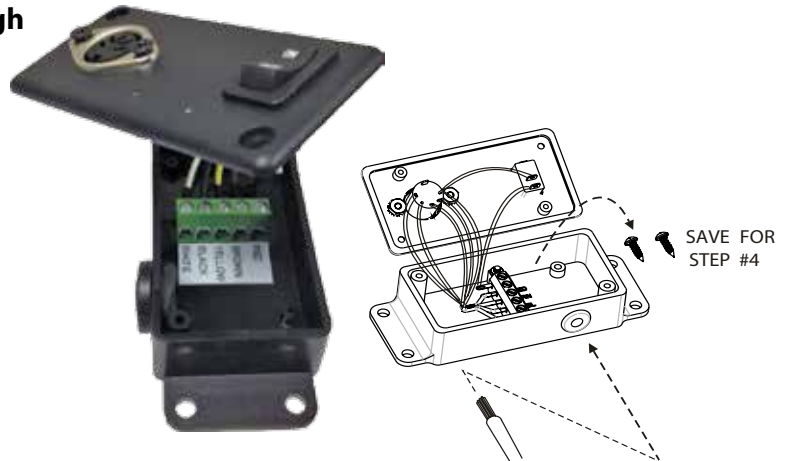

Figure 25-1

4. Pull off the individually pre-stripped insulation ends. Twist each end of the wires individually to keep all the wire strands together. [Figure 25-2]

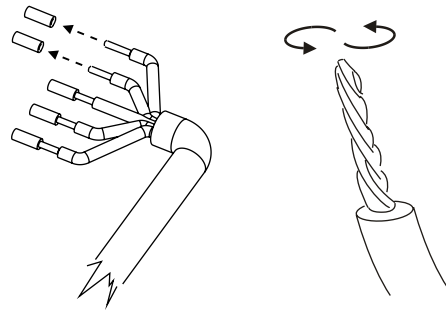

Figure 25-2

5. Insert each color wire into their appropriately-labeled terminal. Tighten each wire down after insertion. [Figure 25-3]

Test each wire by pulling it moderately to make sure that it is secure in the contact block.

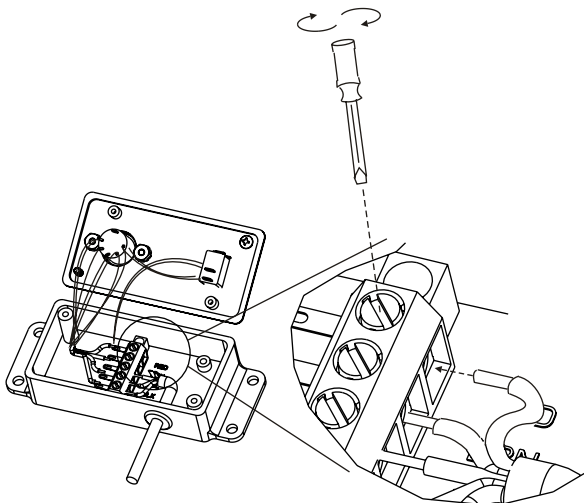

Figure 25-3



6. Carefully fold the enclosure lid back over enclosure to avoid trapping any wires. Use supplied screws (x2) to fasten the lid to the bottom enclosure. [Figure 26-1]

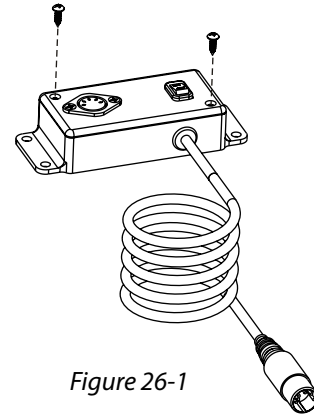

Figure 26-1

7. If customer prefers, fasten enclosure to chosen location using self-drilling screws provided. [Figure 26-2] Do NOT over-torque these screws.

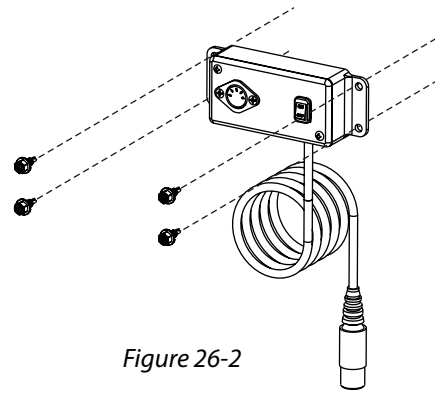

Figure 26-2

8. Plug the hand control into the receptacle in the enclosure. Turn the power switch to the 'ON' position. [Figure 26-3]

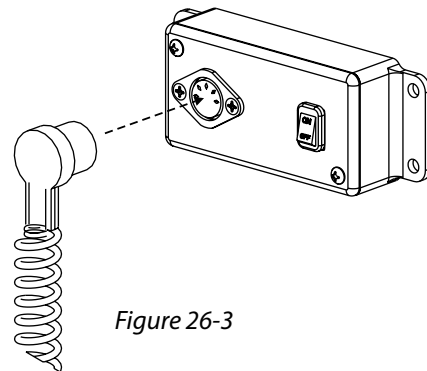

Figure 26-3

Test the lift's motion against the button's on the hand control. [Figure 26-4]



Figure 26-4

Troubleshooting

DEALER/INSTALLER ONLY SECTION

The following procedures are reserved for the approved installer/dealer. They should not be attempted by anyone without proper knowledge of automotive electrical circuitry.



Be careful when troubleshooting with a test light or voltage meter. They may give false indications.

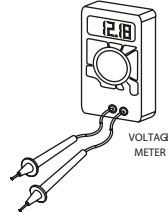

The instruments will detect voltage but may not indicate a tear or poor connection in the wiring.

Be careful when troubleshooting with a test light or voltage meter. They may give a false indication as shown above. They will only indicate that there is some wire connection –not necessarily enough.

We strongly recommend troubleshooting electrical problems with a known good/fully charged 12V automotive battery or known good/fully charged power chair/scooter battery.

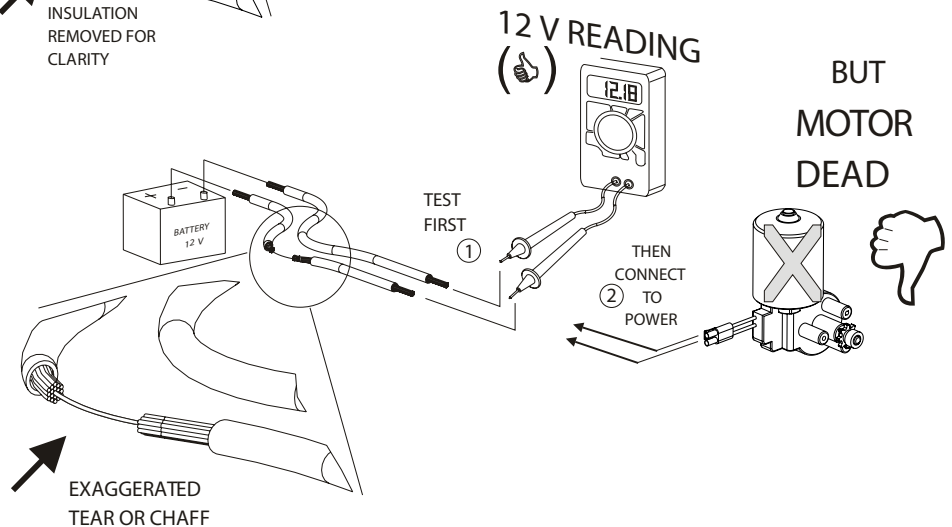
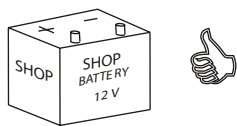
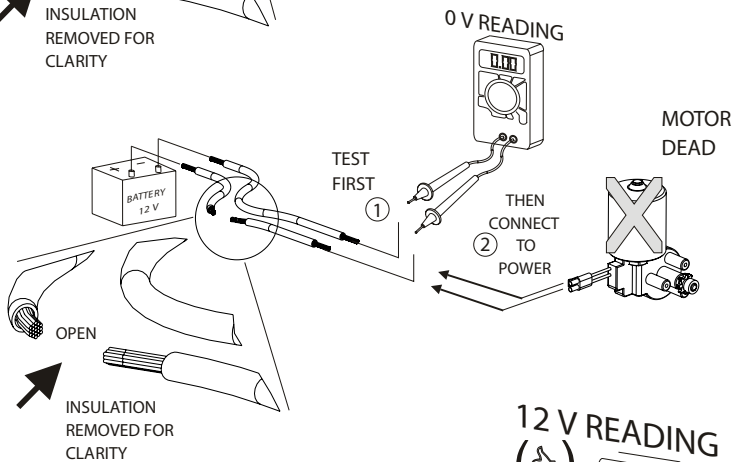
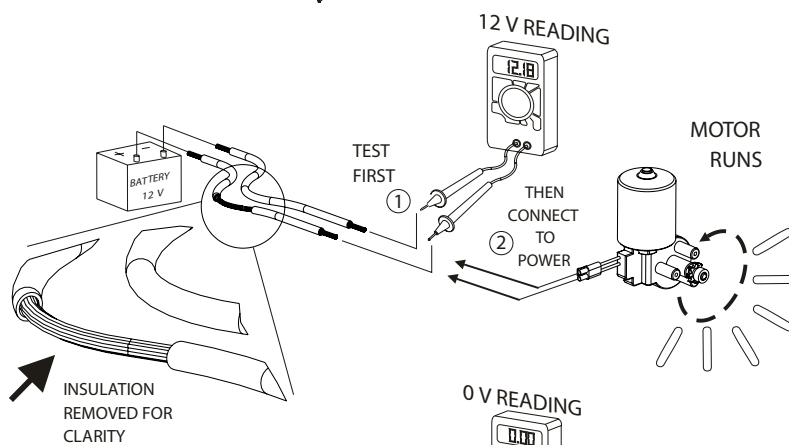

PROBLEM

Lift does not operate or lift operates slowly or intermittently

CAUSE

Bad electrical connection(s) / Circuit breaker

SOLUTION

Check / clean all connections that might be loose or dirty. This is the #1 cause of a poorly performing lift. The lift motor requires quality electrical connections to operate at full capacity; any break in the wiring will slow down the motor and it will deteriorate prematurely.

Inspect the full length of the wire harness to ensure the insulation is not torn. The lift's vehicle power harness running through or under the vehicle is subject to road debris and rubbing against the vehicle's frame which can cause a short.

Verify the circuit breaker. The circuit breaker is located about 6" from the connections to the vehicle's battery. The breaker will self-reset if overloaded; however, verify (with Ohm meter or test light) that the breaker is functioning. [Figure 28-1] Or replace it with a new/known-good circuit breaker and perform the following tests. [Figure 28-2]



Figure 28-1

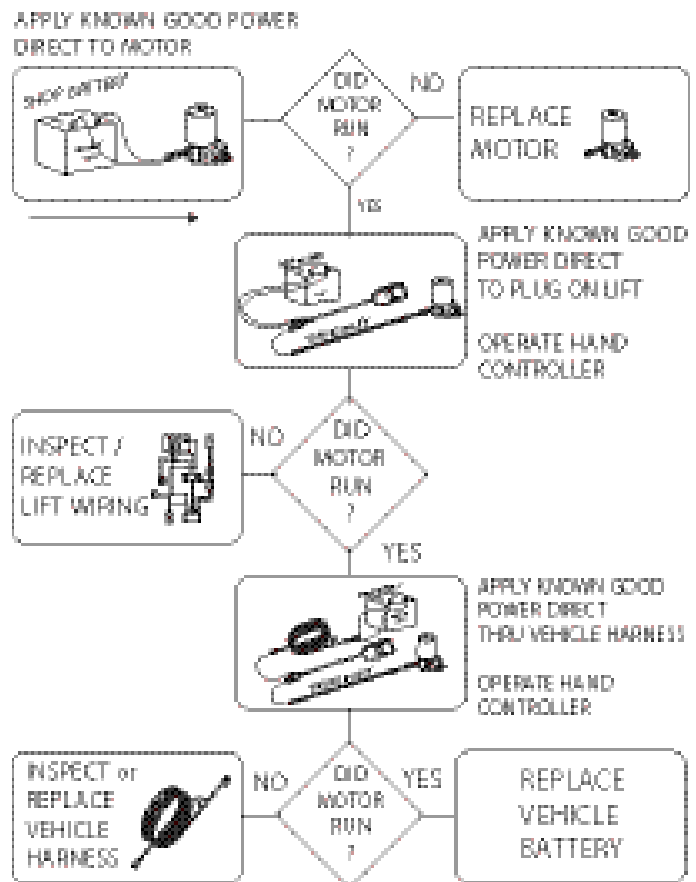

Figure 28-2

PROBLEM

Lift rotates in wrong direction / Not enough rotation / No rotation

CAUSE

Rotation limit switches

SOLUTION

One or more rotational limit switches may be depressed. Switches should be depressed only at the end of travel. See page 21 for rotational limit switch explanation.

PROBLEM

Scooter/ chair tips front or back while being lifted.

CAUSE

Chair or scooter is being lifted off center.

SOLUTION

Adjust for center of gravity on docking device. Check to see if proper docking device is being used.

PROBLEM

Lifting arm is difficult to rotate.

CAUSE

Dry / dirty bushings

SOLUTION

Clean and lubricate bushings in base with white/lithium grease or equivalent.

AL815CC Parts List

ASSEMBLY PARTS			DESCRIPTION
ITEM	QTY	PART NO.	
1	1	210-1D05-CA	PICKUP LIFT POST WELDMENT
2	1	220-1D05-CA	PIVOT ARM WELDMENT TRUCK LIFT
3	1	222-1D04-CA	LONG ARM WELDMENT, TRUCK LIFT
4	1	230-1D05-CA	OUTER ARM WELDMENT - TRUCK LIFT
5	1	275-3D05-AA	POWER ROTATION ASSEMBLY, TRUCK LIFT
6	1	410-1D05-AB	BASE COVER, AL835
7	1	510-1D05-CA	HOOK, DOUBLE STRAP, TRUCK LIFT
8	2	591-ZB01-CA	HOOK SLEEVE
9	2	910-1D05-AA	AL800 SERIES LIFTING STRAP
10	1	920-1D05-AA	DOUBLE STRAP QUICK PIN
11	1	999-3D05-AA	OWNERS MANUAL
12	2	AL207	LONG LEG EXTENSION
13	1	ALA10013	2x SPEED ACTUATOR 20:1 w/ COVERTUBES
14	2	ALA15110	FLANGE BUSHING, 1" DIA, BRONZE
15	1	ALA21094	STICKER, CAUTION
16	1	ALA21095	STICKER
17	4	ALA802188C	AL800 STRAP ATTACHMENT PLATE
18	4	ALA99995	STICKER, SERIAL NUMBER
19	2	BHCS-0_25-20-1_75-SS	BUTTON HEAD, 1/4-20 x 1-3/4", 18-8 SS
20	4	H2688	END CAP (SQUARE 2x2)
21	1	H41000	HAND CONTROL- 4 BUTTON
22	1	H425009	ROUND TUBE PLUG
23	4	HHCS-0_25-28-2_75-Z	HHCS 1/4-20 X 2.75
24	1	HHCS-0_37-16-3_50-Z	HHCS 3/8-16 X 3.25
25	2	HHCS-0_50-13-2_50-Z	HHCS 1/2-13 X 2.25
26	2	HHCS-0_50-13-3_25-Z	HHCS 1/2-13 X 3.25
27	2	HHCS-0_62-11-3_00-NP-68-Z	HHCS, 5/8-11 x 3.00L NYLON PATCH, GRADE 8 ZP
28	2	NUT-0_25-20-ACORN-Z	NUT, ACORN, 1/4-20, ZINC
29	4	NUT-0_25-28-NYLOCK-Z	NYLOCK NUT 1/4-20
30	1	NUT-0_37-16-NYLOC-Z	NYLOCK NUT 3/8-16
31	4	NUT-0_50-13-NYLOCK-Z	NYLOCK NUT 1/2-13
32	1	PIN-0_12-1_50-CO-SS	COTTER PIN 1/8" x 1-1/2" L ZINC
33	1	PIN-1_00-4_00-CL-Z	CLEVIS PIN/OD=1.00, OL=4.00, UL=3.70
34	3	SHCS-0_37-16-2_75-Z	SOCKET HEAD CAP SCREW, 3/8-16 x 2.75" L, ZINC
35	4	SSCP-0_37-0_312-Z	SET SCREW, 3/8-16 x 5/16" L ZINC
36	2	WASH-0_25-0_50-0_06-SL-Z	WASHER, LOC, SPLIT, 1/4", ZINC
37	3	WASH-0_37-0_68-0_09-SL-Z	WASHER, LOC, SPLIT, 1/4", ZINC
38	2	WASH-0_62-1_08-0_15-SL-Z	WASHER, 5/8", SPLIT LOC, ZINC
39	1	WASH-1_07-2_00-0_10-RH-SS	WASHER, FLAT, 1.07 ID x 2.00 OD 18-8SS

AL815CC Assembly

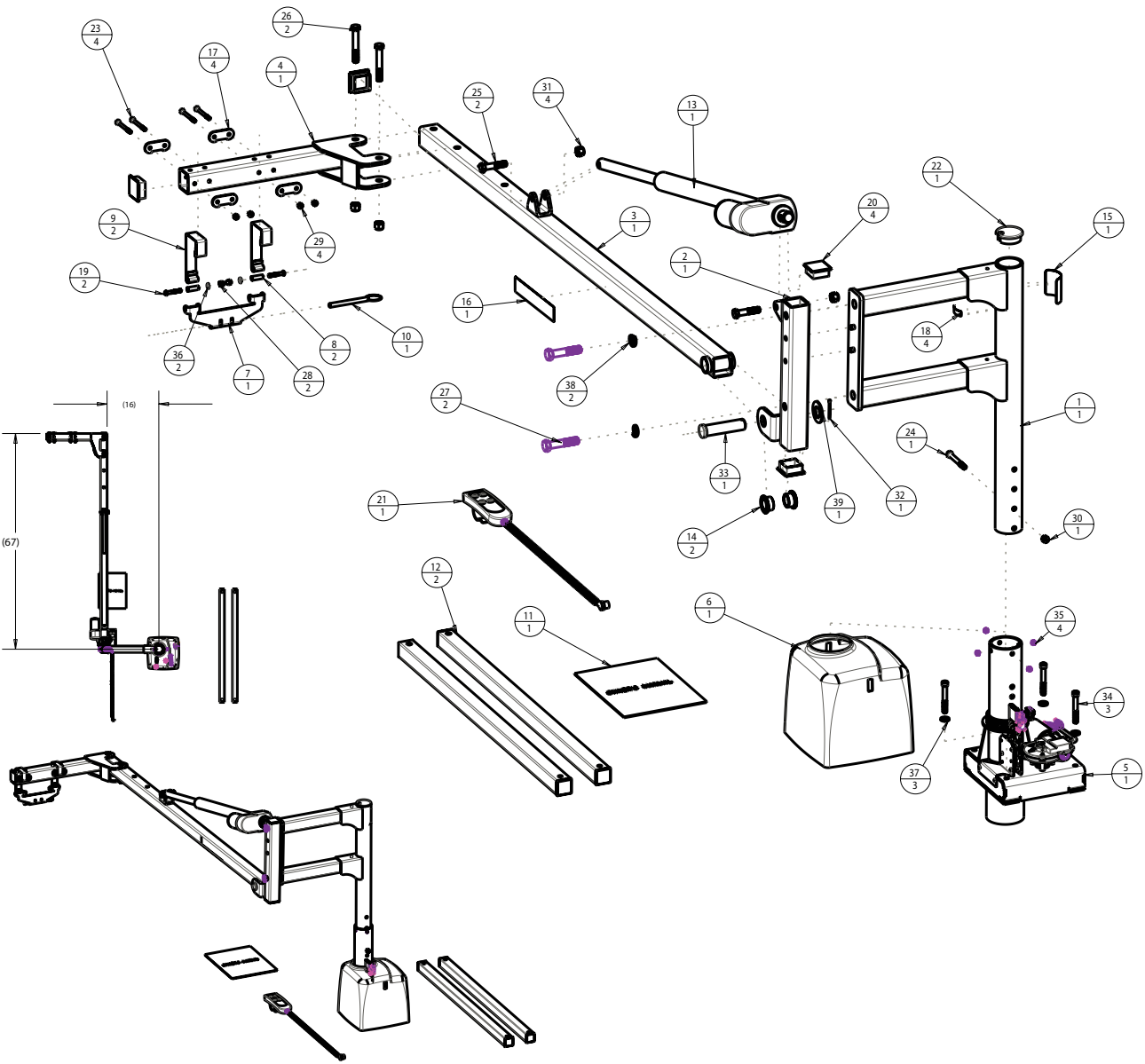

AL825 Parts List

			ASSEMBLY PARTS	
ITEM	QTY	PART NO.	DESCRIPTION	
1	1	210-1D05-CA	PICKUP LIFT POST WELDMENT	
2	1	220-1D05-CA	PIVOT ARM WELDMENT TRUCK LIFT	
3	1	230-1D05-CA	OUTER ARM WELDMENT - TRUCK LIFT	
4	1	275-3D05-AA	POWER ROTATION ASSEMBLY, TRUCK LIFT	
5	1	410-1D05-AB	BASE COVER, AL 835	
6	1	510-1D05-CA	HOOK, DOUBLE STRAP, TRUCK LIFT	
7	2	591-ZB01-CA	HOOK SLEEVE	
8	2	910-1D05-AA	AL800 SERIES LIFTING STRAP	
9	1	920-1D05-AA	DOUBLE STRAP QUICK PIN	
10	1	999-3D05-AA	OWNER'S MANUAL	
11	2	AL207	LONG LEG EXTENSION	
12	1	ALA10013	2X SPEED ACTUATOR 20:1 w/ COVERTUBES	
13	2	ALA15110	FLANGE BUSHING, 1" DIA, BRONZE	
14	1	ALA21094	STICKER, CAUTION	
15	1	ALA21095	STICKER	
16	1	ALA802140C	AL800 ARM	
17	4	ALA802188C	AL800 STRAP ATTACHMENT PLATE	
18	4	ALA99995	STICKER, SERIAL NUMBER	
19	2	BHCS-0_25-20-1_75-SS	BUTTON HEAD, 1/4-20 x 1-3/4" L, 18-8 SS	
20	4	H2688	END CAP (SQUARE 2x2)	
21	1	H41000	HAND CONTROL- 4 BUTTON	
22	1	H425009	ROUND TUBE PLUG	
23	4	HHCS-0_25-28-2_75-Z	HHCS 1/4-20 X 2.75	
24	1	HHCS-0_37-16-3_50-Z	HHCS 3/8-16 X 3.25	
25	2	HHCS-0_50-13-2_50-Z	HHCS 1/2-13 X 2.25	
26	2	HHCS-0_50-13-3_25-Z	HHCS 1/2-13 X 3.25	
27	2	HHCS-0_62-11-3_00-NP-G8-Z	HHCS, 5/8-11 x 3.00L NYLON PATCH, GRADE 8 ZP	
28	2	NUT-0_25-20-ACORN-Z	NUT, ACORN, 1/4-20, ZINC	
29	4	NUT-0_25-28-NYLOCK-Z	NYLOCK NUT 1/4-20	
30	1	NUT-0_37-16-NYLOCK-Z	NYLOCK NUT 3/8-16	
31	4	NUT-0_50-13-NYLOCK-Z	NYLOCK NUT 1/2-13	
32	1	PIN-0_12-1_50-CO-SS	COTTER PIN 1/8" x 1-1/2" L, ZINC	
33	1	PIN-1_00-4_00-CL-Z	CLEVIS PIN:OD=1.00, OL=4.00, UL=3.70	
34	3	SHCS-0_37-16-2_75-Z	SOCKET HEAD CAP SCREW, 3/8-16 x 2.75" L, ZINC	
35	4	SSCP-0_37-0_312-Z	SET SCREW, 3/8-16 x 5/16" L, ZINC	
36	2	WASH-0_25-0_50-0_06-SL-Z	WASHER, LOC, SPLIT, 1/4", ZINC	
37	3	WASH-0_37-0_68-0_09-SL-Z	WASHER, LOC, SPLIT, 1/4", ZINC	
38	2	WASH-0_62-1_08-0_15-SL-Z	WASHER, 5/8", SPLIT LOC, ZINC	
39	1	WASH-1_07-2_00-0_10-RH-SS	WASHER, FLAT, 1.07 ID x 2.00 OD 18-8SS	

AL825 Assembly

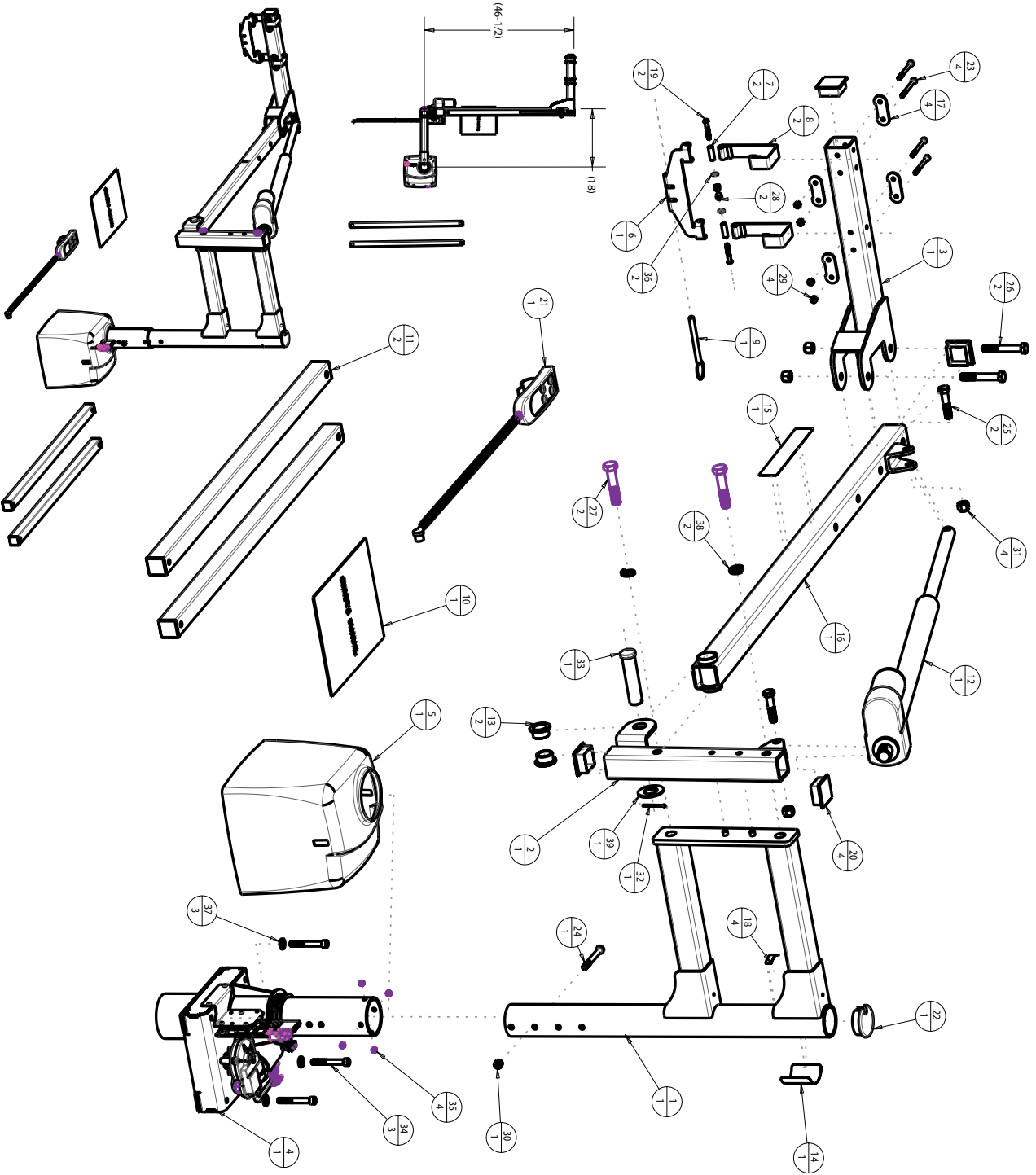

AL825CC Parts List

ITEM	QTY	PART NO.	DESCRIPTION
ASSEMBLY PARTS			
1	1	210-1D05-CA	PICKUP LIFT POST WELDMENT
2	1	220-1D05-CA	PIVOT ARM WELDMENT TRUCK LIFT
3	1	222-1D04-CA	LONG ARM WELDMENT, TRUCK LIFT
4	1	230-1D05-CA	OUTER ARM WELDMENT - TRUCK LIFT
5	1	275-3D05-AA	POWER ROTATION ASSEMBLY, TRUCK LIFT
6	1	410-1D05-AB	BASE COVER, AL835
7	1	510-1D05-CA	HOOK, DOUBLE STRAP, TRUCK LIFT
8	2	591-ZB01-CA	HOOK SLEEVE
9	2	910-1D05-AA	AL800 SERIES LIFTING STRAP
10	1	920-1D05-AA	DOUBLE STRAP QUICK PIN
11	1	999-3D05-AA	OWNER'S MANUAL
12	2	AL207	LONG LEG EXTENSION
13	1	ALA10011	ACTUATOR 40:1 WITH COVER TUBES
14	2	ALA15110	FLANGE BUSHING, 1" DIA, BRONZE
15	1	ALA21094	STICKER, CAUTION
16	1	ALA21095	STICKER
17	4	ALAB02188C	AL800 STRAP ATTACHMENT PLATE
18	4	ALA99995	STICKER, SERIAL NUMBER
19	2	BHCS-0_25-20--1_75-SS	BUTTON HEAD, 1/4-20 x 1-3/4"L, 18-8 SS
20	4	H2688	END CAP (SQUARE 2x2)
21	1	H41000	HAND CONTROL- 4 BUTTON
22	1	H425009	ROUND TUBE PLUG
23	4	HHCS-0_25-28--2_75-Z	HHCS 1/4-20 X 2.75
24	1	HHCS-0_37-16--3_50-Z	HHCS 3/8-16 X 3.25
25	2	HHCS-0_50-13--2_50-Z	HHCS 1/2-13 X 2.25
26	2	HHCS-0_50-13-3_25-Z	HHCS 1/2-13 X 3.25
27	2	HHCS-0_62-11-3_00-NP-G8-Z	HHCS 5/8-11 x 3.00L NYLON PATCH, GRADE 8 ZP
28	2	NUT-0_25-20-ACORN-Z	NUT, ACORN, 1/4-20, ZINC
29	4	NUT-0_25-28-NYLOCK-Z	NYLOCK NUT 1/4-20
30	1	NUT-0_37-16-NYLOCK-Z	NYLOCK NUT 3/8-16
31	4	NUT-0_50-13-NYLOCK-Z	NYLOCK NUT 1/2-13
32	1	PIN-0_12--1_50-CO-SS	COTTER PIN 1/8" x 1-1/2"L ZINC
33	1	PIN-1_00--4_00-CL-Z	CLEVIS PIN:OD=1.00, OL=4.00, UL=3.70
34	3	SHCS-0_37-16-2_75-Z	SOCKET HEAD CAP SCREW, 3/8-16 x 2.75"L, ZINC
35	4	SSCP-0_37--0_312-Z	SET SCREW, 3/8-16 x 5/16"L, ZINC
36	2	WASH-0_25-0_50-0_06-SL-Z	WASHER, LOC, SPLIT, 1/4", ZINC
37	3	WASH-0_37-0_68-0_09-SL-Z	WASHER, LOC, SPLIT, 1/4", ZINC
38	2	WASH-0_62-1_08-0_15-SL-Z	WASHER, 5/8", SPLIT LOC, ZINC
39	1	WASH-1_07-2_00--0_10-RH-SS	WASHER, FLAT, 1.07 ID x 2.00 OD 18-8SS

AL825CC Assembly

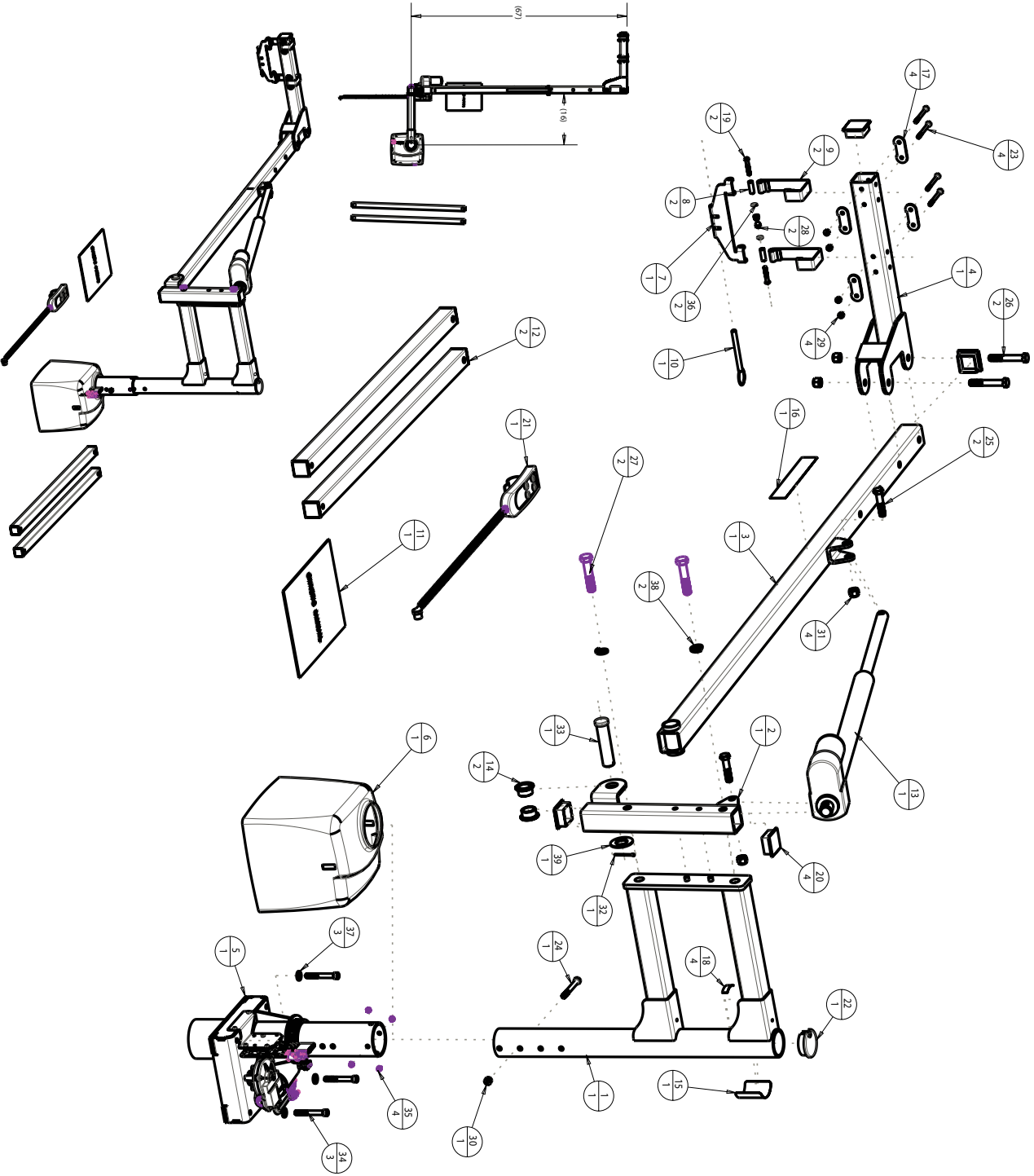

AL835 Parts List

			ASSEMBLY PARTS	
ITEM	QTY	PART NO.	DESCRIPTION	
1	1	210-1D05-CA	PICKUP LIFT POST WELDMENT	
2	1	220-1D05-CA	PIVOT ARM WELDMENT TRUCK LIFT	
3	1	230-1D05-CA	OUTER ARM WELDMENT - TRUCK LIFT	
4	1	275-3D05-AA	POWER ROTATION ASSEMBLY, TRUCK LIFT	
5	1	410-1D05-AB	BASE COVER, AL835	
6	1	510-1D05-CA	HOOK, DOUBLE STRAP, TRUCKLIFT	
7	2	591-ZB01-CA	HOOK SLEEVE	
8	2	910-1D05-AA	AL800 SERIES LIFTING STRAP	
9	1	920-1D05-AA	DOUBLE STRAP QUICK PIN	
10	1	999-3D05-AA	OWNER'S MANUAL	
11	2	AL207	LONG LEG EXTENSION	
12	1	ALA10011	ACTUATOR 40:1 WITH COVER TUBES	
13	2	ALA15110	FLANGE BUSHING, 1" DIA, BRONZE	
14	1	ALA21094	STICKER, CAUTION	
15	1	ALA21095	STICKER	
16	1	ALA802140C	AL800 ARM	
17	4	ALA802188C	AL800 STRAP ATTACHMENT PLATE	
18	4	ALA99995	STICKER, SERIAL NUMBER	
19	2	BHCS-0_25-20--1_75-SS	BUTTON HEAD, 1/4-20 x 1-3/4", 18-8 SS	
20	4	H2688	END CAP (SQUARE 2x2)	
21	1	H41000	HAND CONTROL- 4 BUTTON	
22	1	H425009	ROUND TUBE PLUG	
23	4	HHCS-0_25-28--2_75-Z	HHCS 1/4-20 X 2.75	
24	1	HHCS-0_37-16--3_50-Z	HHCS 3/8-16 X 3.25	
25	2	HHCS-0_50-13--2_50-Z	HHCS 1/2-13 X 2.25	
26	2	HHCS-0_50-13-3_25-Z	HHCS 1/2-13 X 3.25	
27	2	HHCS-0_62-11-3_00-NP-G8-Z	HHCS 5/8-11 x 3.00L NYLON PATCH, GRADE 8 ZP	
28	2	NUT-0_25-20-ACORN-Z	NUT, ACORN, 1/4-20, ZINC	
29	4	NUT-0_25-28-NYLOCK-Z	NYLOCK NUT 1/4-20	
30	1	NUT-0_37-16-NYLOCK-Z	NYLOCK NUT 3/8-16	
31	4	NUT-0_50-13-NYLOCK-Z	NYLOCK NUT 1/2-13	
32	1	PN-0_12--1_50-CO-SS	COTTER PIN 1/8" x 1-1/2" L ZINC	
33	1	PN-1_00--4_00-CL-Z	CLEVIS PIN=1.00, OL=4.00, UL=3.70	
34	3	SHCS-0_37-16-2_75-Z	SOCKET HEAD CAP SCREW, 3/8-16 x 2.75" L, ZINC	
35	4	SSCP-0_37--0_312-Z	SET SCREW, 3/8-16 x 5/16" L ZINC	
36	2	WASH-0_25-0_50-0_06-SL-Z	WASHER, LOC, SPLIT, 1/4", ZINC	
37	3	WASH-0_37-0_68-0_09-SL-Z	WASHER, LOC, SPLIT, 1/4", ZINC	
38	2	WASH-0_62-1_08-0_15-SL-Z	WASHER, 5/8", SPLIT LOC, ZINC	
39	1	WASH-1_07-2_00--0_10-RH-SS	WASHER, FLAT, 1.07 ID x 2.00 OD 18-8SS	

AL835 Assembly

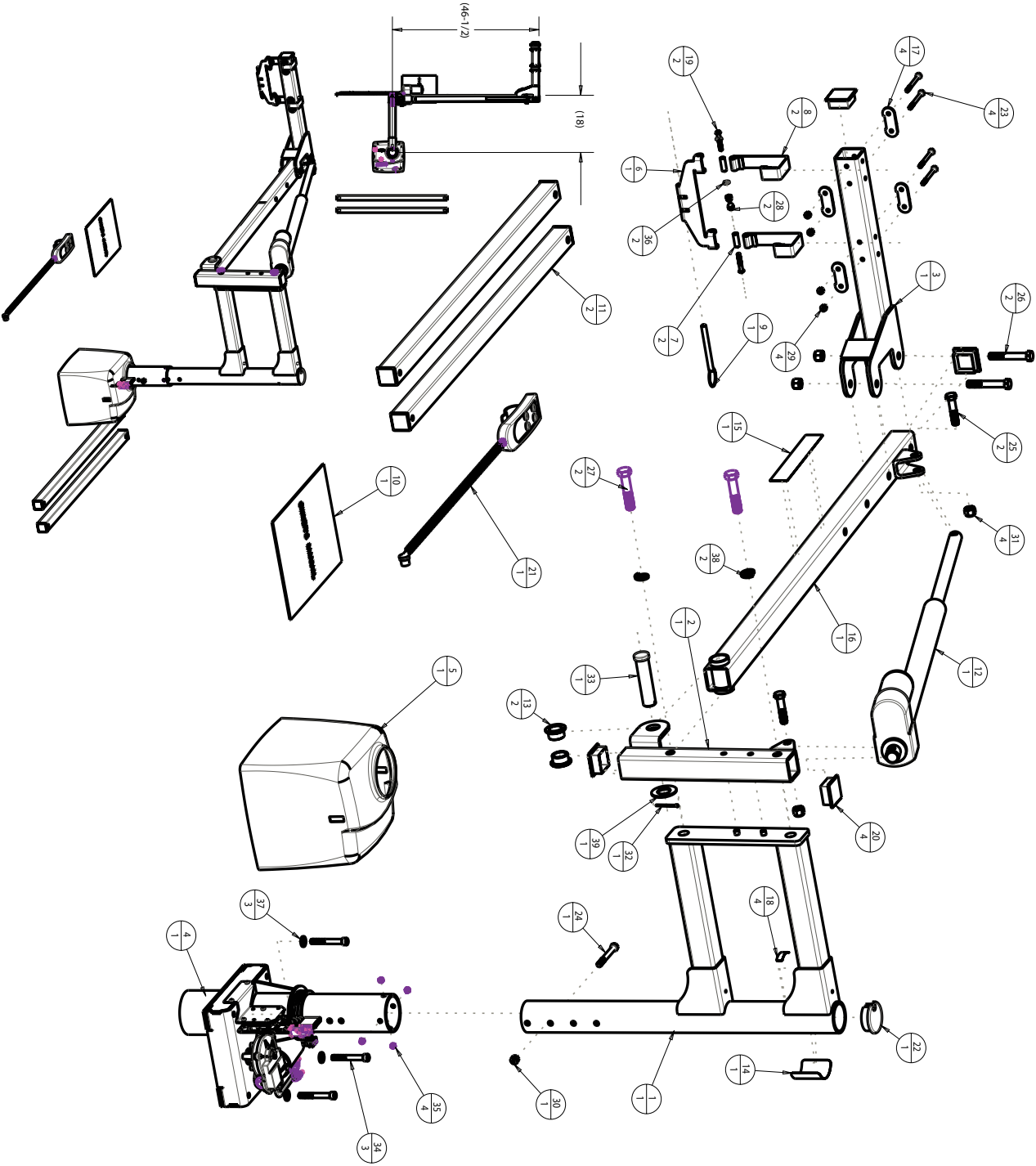

Power Base Parts List

ITEM	QTY	PART NO.	ASSEMBLY PARTS	DESCRIPTION
1	1	201-ZB03-CE		MOTOR HOUSING
2	1	250-1D05-CA		MOTOR HOUSING COVER WELD
3	1	255-1D05-CC		OUTER POST TUBE
4	1	400-3B01-AA		FLANGE BUSHING
5	1	401-3B01-AA		CUP BUSHING
6	1	529-ZB03-CD		MOTOR HOUSING - GEAR PLATE
7	2	530-ZB03-CC		LIMIT RING
8	1	577-1D05-CA		PCB PLATE
9	1	700-1D02-AB		MOTOR, ANIKARSRUM, KSV 4030-822
10	1	ALA21411		BEARING,FLANGE, 3/8"ID x 1/2"OD x 1/2"OAL
11	4	BHCS-0_25-20--0_50-SS		BHCS 1/4-20 X 0.50
12	4	BHCS-10-24--0_62-BO		SCS 10-24 X 5/8
13	3	BHCS-M6-1_00-16-SS		BUTTON HEAD CAP SCREW < M6-16mm, 18-8SS
14	1	H425054		HARNES, AL425
15	1	H425231		MOTOR HOUSING GEAR PIN - A
16	1	H425232		MOTOR HOUSING GEAR PIN - B
17	1	H425240		DOUBLE SPROCKET 19-35, 8-35
18	1	H425241		DOUBLE SPROCKET 19-35, 8-40
19	1	H425255		AL425/435 LIMIT SWITCH SPACER
20	1	H425262		BUSHING BRONZE 1/2 ID x 5/8" OD x 5/8"OAL
21	1	H425263		BEARING,FLANGE, 3/8" ID x 7/8" OD x 1/2"OAL
22	1	H425264		BUSHING FLANGE, BRONZE 1/2 ID x 1" OD x 1/2" OAL
23	2	H425900		35 PITCH CHAIN LOOP, 26 LINKS
24	1	H425901		40 PITCH CHAIN LOOP, 33 LINKS
25	3	NUT-6-32-NYLOCK-SS		NYLOCK NUT # 6-32
26	2	PHMS-2-56--1_00-SS		MS #2-56 X 1.00
27	5	PHMS-6-32-0_50-Z		MACHINE SCREW # 6-32 X 0.50
28	1	RHSS-0_25-20--0_25-N		1/4-20 x .25" NYLON Flat Head
29	1	RR-0_37-EC-Z		E-CLIP 3/8 SHAFT OD
30	1	RR-0_50-EC-Z		E-CLIP 1/2 SHAFT OD
31	3	SPCR-0_14-0_31--0_18-P		SPACER;ID=#6, OD=.313
32	2	SSCP-8-32--0_50-SS		SET SCREW 8-32 X 0.50
33	3	WASH-0_25-0_50--0_06-SL-Z		1/4" SPLIT LOCK WASHER
34	2	WASH-0_37-0_62-0_06-RH-SS		WASHER, 3/8" ID x 5/8" OD x 0.06" THICK, 18-8SS
35	3	WASH-0_50--0_88-Z		WASHER, 1/2" ID x 7/8" OD x 0.075" THICK, ZP

Power Base Assembly

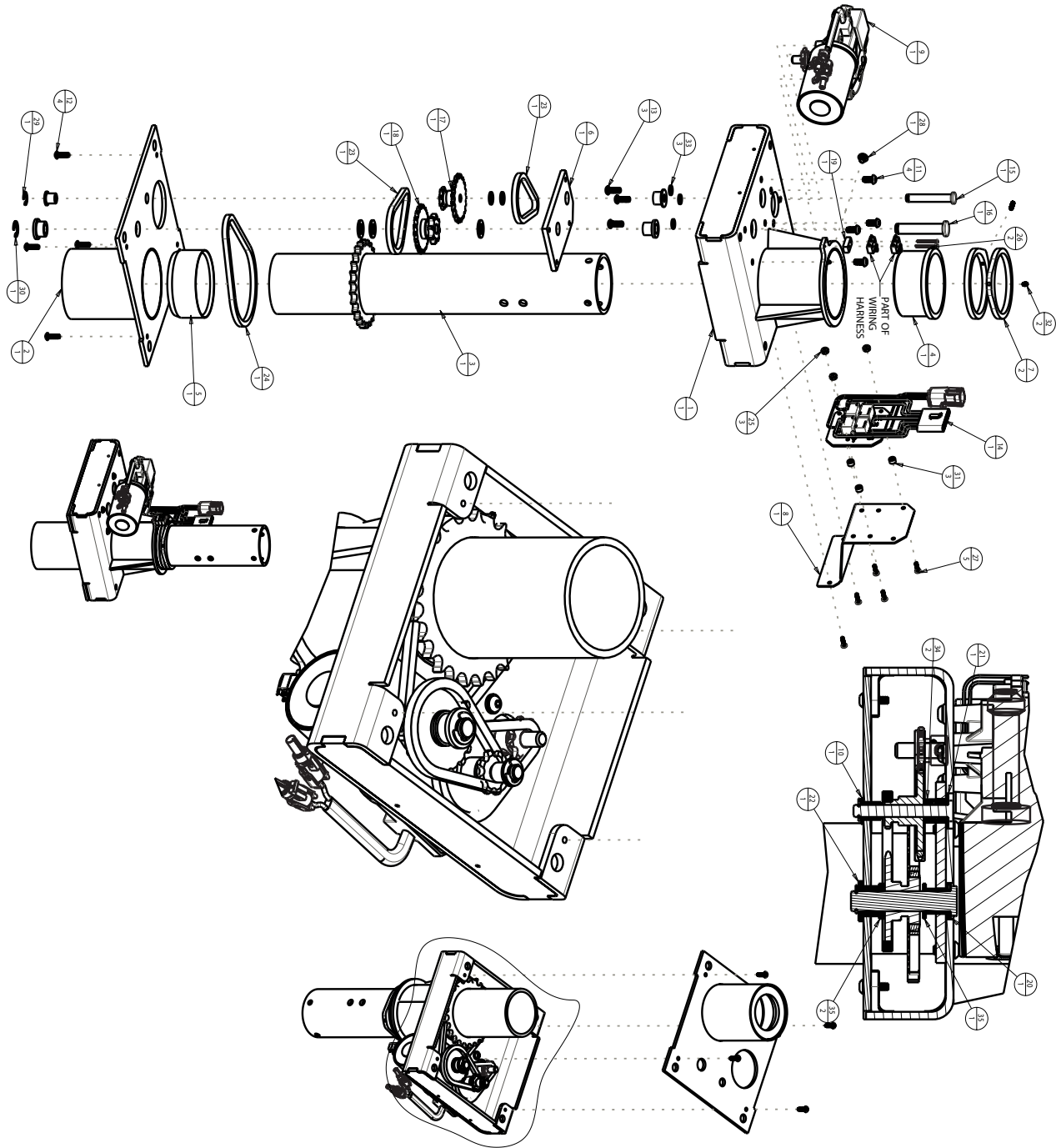

Service Description:

Service Date:

Performed By:

Service Description:

Service Date:

Performed By:

Service Description:

Service Date:

Performed By:

Service Description:

Service Date:

Performed By:

Service Description:

Service Date:

Performed By:

Service Description:

Service Date:

Performed By:

VEHICLE LIFTS THREE YEAR TRANSFERABLE LIMITED WARRANTY

PLEASE FILL OUT ALL FIELDS AND RETURN A COPY.

Fax completed form to 1-866-234-5680 or mail to Harmar, ATTN: Warranty Department, 2075 47th Street, Sarasota, Florida 34234. You may also register online at www.harmar.com. Keep a copy of this form for your records.

Harmar Mobility warrants its lift products against defects in material, mechanical and electrical components (parts), excluding labor cost, batteries, paint and covers, for a period of three (3) years from date of retail purchase, provided that the products have been installed, maintained and operated properly. This warranty does not cover defects in vehicles on which Harmar products are installed or defects in Harmar products caused by defects in any part of the vehicle upon which the product is installed. This warranty does not cover maintenance or adjustments. Harmar will not be charged for labor, consequential damage or repair expenses. Harmar will not, under any circumstances, be liable for the loss of the use of its products or loss of time. This warranty becomes null and void if the product has been lost, damaged by accident, over-stressed, misused and/or neglected, or if the product has been modified in any way. Defective parts must be returned, prepaid, to Harmar at the address listed above, for inspection prior to credit, repair or replacement, at Harmar's option. Harmar's sole obligation and the exclusive remedy under this warranty is limited to such credit, repair or replacement.

THIS EXPRESS WARRANTY IS IN LIEU OF ALL OTHER WARRANTIES OR CONDITIONS, INCLUDING ALL IMPLIED WARRANTIES OR MERCHANTABILITY OR FITNESS FOR A PARTICULAR PURPOSE, AND THERE ARE NO WARRANTIES THAT EXTEND BEYOND THE DESCRIPTION OF THE LIMITED WARRANTY DESCRIBED HEREIN. THIS WARRANTY GIVES YOU SPECIFIC LEGAL RIGHTS AND YOU MAY ALSO HAVE OTHER LEGAL RIGHTS WHICH VARY FROM STATE TO STATE.

PRODUCT INFORMATION

Model: _____

Serial Number: _____

Purchase Date: _____

INSTALLER INFORMATION

Company Name: _____

Contact Name: _____

 Address: _____

Phone: _____

Fax: _____

Email: _____

APPLICATION INFORMATION
 Scooter Power Chair Wheelchair

Year: _____

Manufacturer: _____

Model: _____

PURCHASER INFORMATION

Name: _____

 Address: _____

Phone: _____

Email: _____

ADDITIONAL INFORMATION
How did you hear about Harmar?

- | | |
|--|---|
| <input type="checkbox"/> Harmar Dealer | <input type="checkbox"/> Friend or Acquaintance |
| <input type="checkbox"/> Internet | <input type="checkbox"/> Saw Harmar product somewhere |
| <input type="checkbox"/> Magazine | <input type="checkbox"/> Other _____ |

Which _____

Do you have internet access? Yes No

I purchased my Harmar lift because of?

- | |
|--|
| <input type="checkbox"/> Style/Appearance |
| <input type="checkbox"/> Harmar Representative |
| <input type="checkbox"/> Previous Experience |
| <input type="checkbox"/> Ease of Use |
| <input type="checkbox"/> Recommendation |
| <input type="checkbox"/> Price/Value |

Harmar • 800-833-0478 • www.harmar.com • 2075 47th Street Sarasota, Florida 34234

Truck Lifts

AL815CC, AL825, AL825CC, AL835
Installation & Owner's Manual



Harmar[®]
Lifts for Life

www.harmar.com | 800-833-0478
2075 47th Street Sarasota, Florida 34234