

# HIGHLANDER II WITH ENCLOSURE PLATFORM LIFT

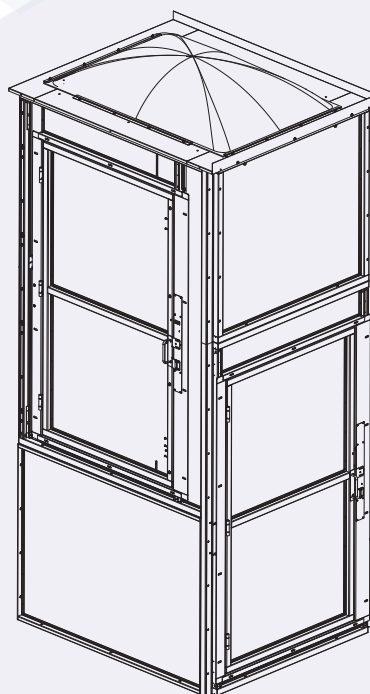

## INSTALLATION & SERVICE MANUAL





**TABLE OF CONTENTS**

<b>SAFETY</b> .....	<b>4</b>	<b>INSTALLATION</b> .....	<b>14</b>
Safety Definition .....	4	No Hoistway / No Floor Penetration .....	14
Environmental Cautions .....	4	Electrical Connection .....	14
<b>INTRODUCTION</b> .....	<b>5</b>	Battery Backup .....	16
Device Name: Harmar Highlander II		Platform Connection .....	16
with Enclosure Platform Lift .....	5	Installing a 90° Platform (If Necessary) .....	17
Read and Understand .....	5	Installing the Platform Control Guard Panel .....	17
Technical Specifications .....	5	Installing the Platform Front Guard Panel .....	17
Code Statement .....	5	Weatherizing the Enclosure .....	17
Applicable Standards Based		Installing Enclosure Tower Walls .....	18
on Installation Type .....	5	Installing the Dome .....	20
Requirements under ASME A18.1 .....	6	Installing the Top Landing Gate	
ASME A18.1 Section 2: Vertical Platform Lifts .....	6	(If Necessary) .....	20
ASME A18.1 Section 5:		Setting the Upper Limit Switch .....	21
Private Residence Vertical Platform Lifts .....	6	Call Stations .....	22
Statement of Use .....	6	Doors by Others .....	22
Key Vertical Platform Lift Elements .....	7	Final Positioning and Anchoring .....	23
Key Internal Vertical Platform Lift Elements .....	8	Installing Fixed Ramps .....	23
<b>PREPARATION</b> .....	<b>9</b>	Installation Tower Check .....	24
Required Tools and Hardware .....	9	Final Installation .....	24
Recommended Tools .....	9	Operational Check .....	25
Box Content .....	10	Permanent Power Installation .....	25
Required Components Not Supplied .....	10	Operator Familiarization .....	26
Unloading .....	10	<b>INSTALLATION QUICK START</b> .....	<b>27</b>
Unpacking .....	10	<b>TROUBLESHOOTING</b> .....	<b>28</b>
Concrete .....	11	Status Codes .....	28
Material Handling .....	11	Control Electronics .....	31
Site Preparation .....	11	Control Electronics Tray .....	31
Placing the VPL .....	12	Control Board .....	32
		Gearmotor .....	37
		Contactor Tray .....	38
		Up and Down Contactors .....	38
		E-Brake Resistor .....	38
		Load Resistors .....	38
		Cooling Fan .....	38
		Battery Backup .....	38
		Float Switch .....	40
		Emergency Evacuation Procedure .....	40
		Emergency Lowering Procedure .....	40
		<b>MAINTENANCE &amp; INSPECTION</b> .....	<b>42</b>
		Residential Applications .....	42
		Commercial Applications .....	42
		Maintenance Schedule .....	43



# SAFETY

## SECTION 1

# SAFETY

## SAFETY DEFINITIONS



This safety alert symbol appears with safety statements. It means attention, become alert, your safety and the safety of others are involved! Please read and abide by the message that follows the safety alert symbol.

### **WARNING**

Indicates a hazardous situation that, if not avoided, could result in death or serious injury.

### **CAUTION**

Indicates a hazardous situation that, if not avoided, could result in minor or moderate injury.

### **NOTICE**

*Indicates a situation which can cause damage to the lift and/or the environment, or cause the lift to operate improperly.*

*NOTE: Indicates a condition that should be followed in order for the lift to function in the manner intended.*

## ENVIRONMENTAL CONDITIONS

The technician shall assess the surrounding conditions and verify that the location is acceptable before performing installation and/or servicing tasks. Installation shall not proceed in inclement weather conditions that jeopardize the technician's safety or ability to complete the installation in a safe manner. Tents, canopies or other outdoor provisions that help protect the work area from weather or other safety concerns are recommended when conditions warrant.

If you do not understand any portion of the installation or operation procedures, please consult Harmor's LiftSquad Support at 800-833-0478.

Do not attempt to install or use this lift if you have any hesitation or question. Serious injury or damage can result if proper procedures are not followed.

## SECTION 2

**INTRODUCTION****DEVICE NAME:  
HIGHLANDER II WITH  
ENCLOSURE PLATFORM LIFT**

Indications of Use: The Harmar Highlander II with Enclosure Platform Lift is designed to assist the transfer of patients or mobility impaired persons and their mobility device, up and down levels of a commercial facility or residence.

**READ AND UNDERSTAND**

This manual provides instructions for the proper installation and service of the Harmar Highlander II with Enclosure Platform Lift which is critical to the lift's safety, performance and durability. Please refer to the Owner's Manual for operating instructions. Any alterations to the equipment without written authorization by the manufacturer is prohibited and will void the warranty.

**TECHNICAL SPECIFICATIONS**

Visit [harmar.com](http://harmar.com) for specifications on the particular lift model and configuration.

**CODE STATEMENT**

The Harmar Highlander II lift has been designed to meet ASME A18.1 "Safety Standard for Platform Lifts and Stairway Chairlifts" under section 2 or section 5 and has been certified to CAN/CSA-B44.1/ ASME A17.5 "Elevator and Escalator Electrical Equipment".

Code requirements for Vertical Platform lifts may vary depending on location. It is the installers responsibility to contact their state, city or local code enforcement office and determine all the regulations the lift and installation are subject to. You must do this before installing the Vertical Platform Lift.

**APPLICABLE STANDARDS  
BASED ON INSTALLATION  
TYPE**

Commercial and residential installations require compliance to the ASME A18.1 safety code and other codes that may be adopted by state, city and local code authority having jurisdiction.

To meet the full intent of ASME A18.1 regulation the installer is required to contact their state, city or local code authority having jurisdiction for permits, adopted rules and inspections of the vertical platform lift.

# INTRODUCTION

---

## REQUIREMENTS UNDER ASME A18.1

ASME A18.1 Safety Standards for Platform Lifts and Stairway Chairlifts under Section 2 or Section 5.

The Harmar Highlander II Vertical Platform Lift is to be installed according to all applicable codes in accordance with ASME A18.1 - which is the responsibility of the installer - ASME A17.5 and CAN/CSA-B44.1.

### ASME A18.1 SECTION 2: VERTICAL PLATFORM LIFTS

*Section 2* applies to vertical platform lifts installed in locations other than in or at a private residence for use by the mobility impaired.

#### RUNWAYS

Runways shall be installed in accordance with 2.1.1, or 2.1.2. Runway construction for lifts that penetrate a floor must comply with 2.1.1 and with the building code.

*NOTE: There are 3 different sections of rules for a commercial application.*

- *2.1.1 Runway Enclosure Provided*
- *2.1.2 Partial Runway Enclosure Provided*

### ASME A18.1 SECTION 5: PRIVATE RESIDENCE VERTICAL PLATFORM LIFTS

*Section 5* applies to vertical platform lifts installed in or at a private residence for use by the mobility impaired.

#### RUNWAYS

Runways shall be installed in accordance with 2.1.1, 2.1.2, or 5.1.1. Runway construction for lifts that penetrate a floor must comply with 2.1.1 and with the building code. Only lifts installed in conformance with 2.1.1 shall serve more than two landings.

### STATEMENT OF USE

Highlander II units with lift heights below 101" (VPL400-800) are intended for a maximum operation of 24-cycles per hour. Units with lift heights above 101" (VPL1000-1400) are intended for a maximum operation of 12-cycles per hour.

**KEY VERTICAL PLATFORM LIFT ELEMENTS**

- 1. Dome (option)
- 2. Lift Status Indicator Lights
- 3. Bottom Door
- 4. Frame
- 5. Platform
- 6. Top Landing Door (if specified)
- 7. Ventilation System (option)
- 8. Platform Controls
- 9. Fixed Ramp
- 10. Panel (plexiglass shown)

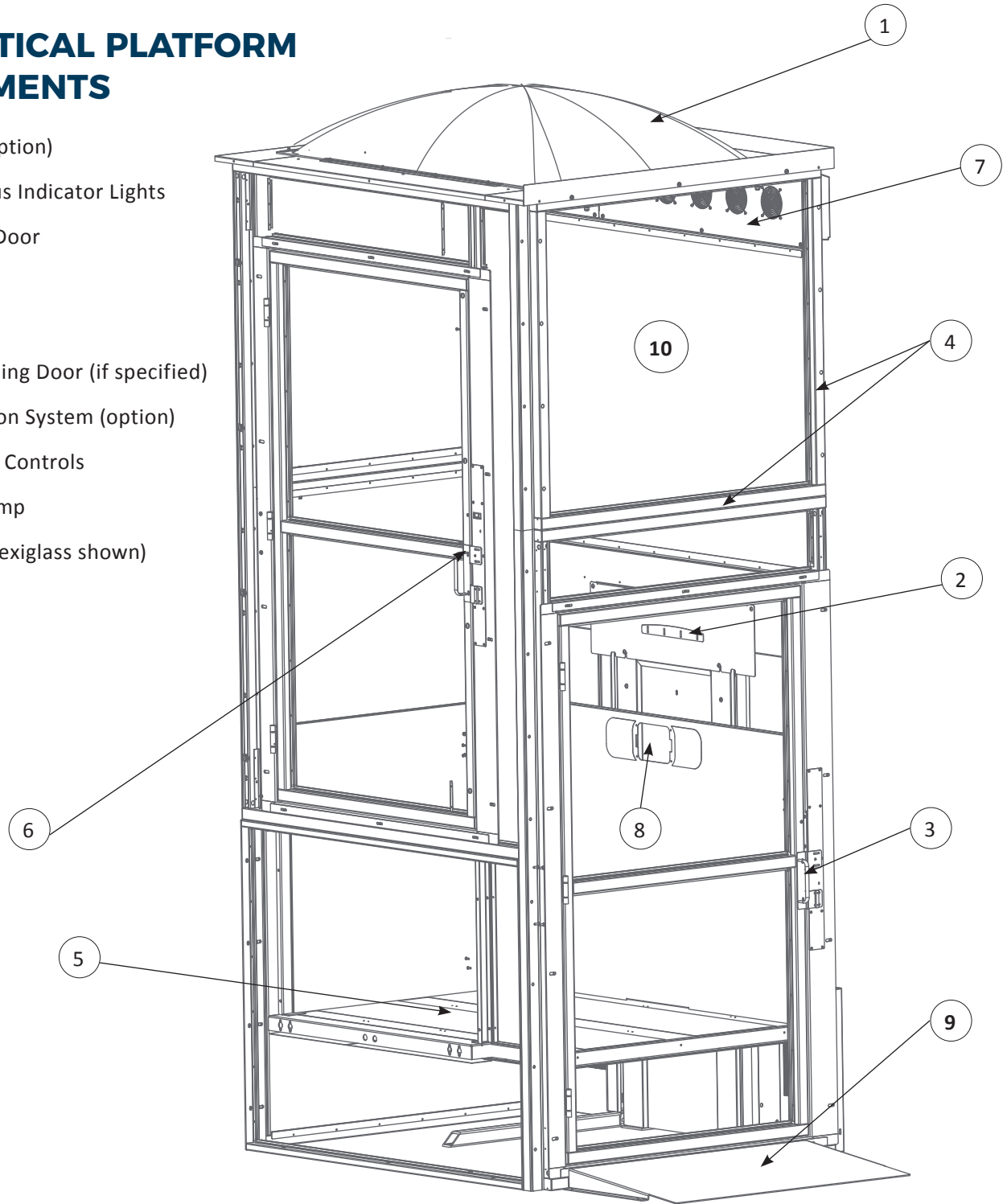

# INTRODUCTION

## KEY INTERNAL VERTICAL PLATFORM LIFT ELEMENTS

1. Manual Lowering Tool
2. Motor / Gearbox
3. ACME Screw
4. Batteries (if supplied)
5. Battery Charger and assembly (tray) (if supplied) (not shown)
6. Inverter (if supplied)
7. Control Electronics Assembly
8. Upper / Lower / Final Limit Switches
9. Tower Frame
10. Tower Legs
11. Wire Channel
12. Over-Speed Safety Assembly
13. Motor Contactors
14. Carriage
15. Trailing Cable
16. Cable Tensioning Pulley
17. Junction Box (Main Power Supply Hookup)

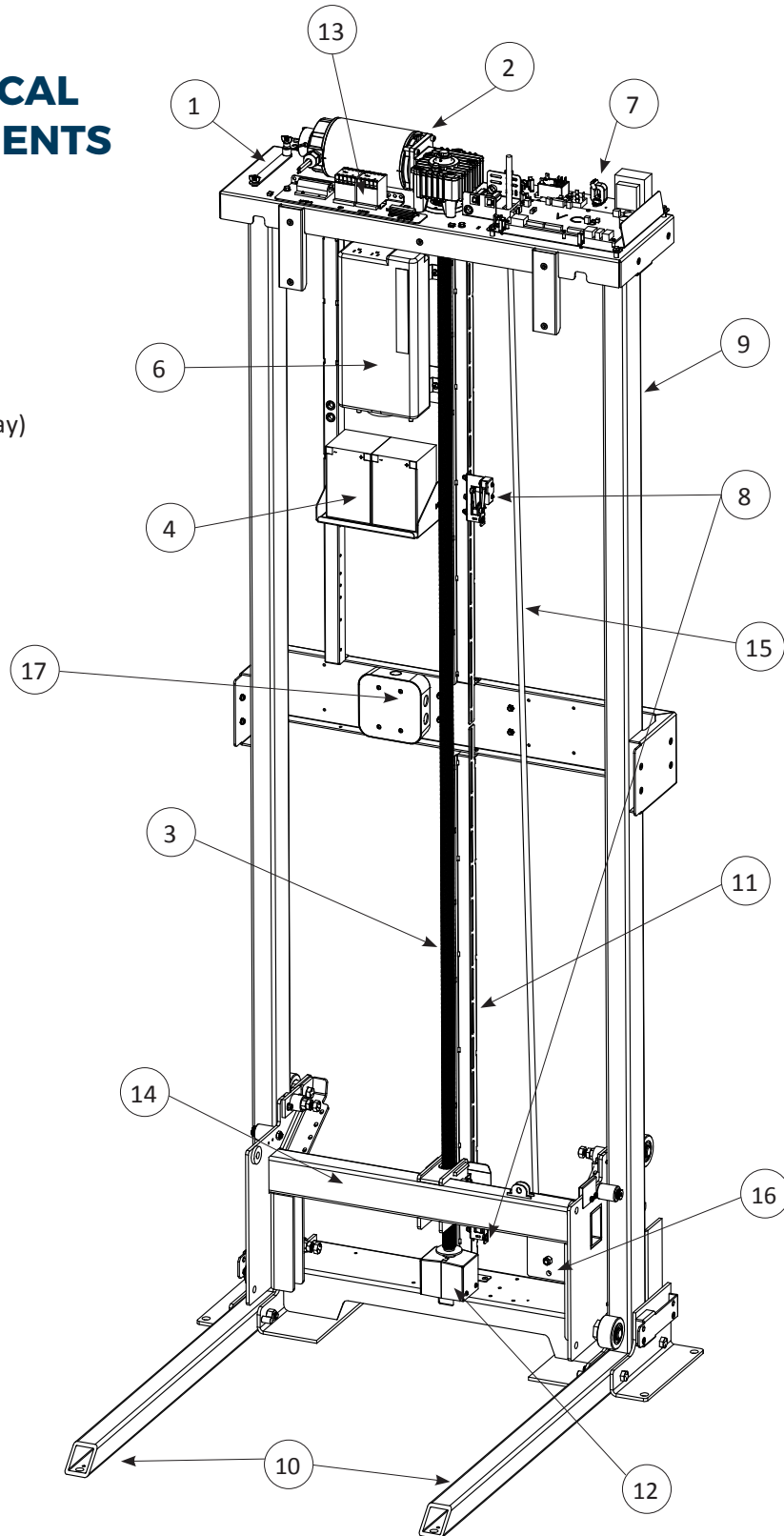

## SECTION 3 **PREPARATION**

Installations may vary to some degree, but below are the basic tools to have on hand for a Highlander II with Enclosure Platform Lift installation.

Depending on the height of the application, you may need to use a scissor lift or crane.

If you have any questions, concerns or comments, please contact our LiftSquad Support at 800-833-0478 or tech@harmar.com.

### **REQUIRED TOOLS AND HARDWARE**

- Tape Measure
- Grounding Strap
- Square
- Level
- Multimeter
- Wire Cutters, Wire Puller
- Stripper, Crimping Tool
- Hammer Drill
  - $\frac{3}{8}$ "
- Wrench Set:
  - $\frac{7}{16}$ "
  - $\frac{1}{2}$ "
  - $\frac{9}{16}$ "
  - $\frac{3}{4}$ "
- Allen Wrench:
  - $\frac{1}{8}$ "
  - $\frac{3}{16}$ "
  - $\frac{5}{16}$ "
- Torx Wrench
  - T20
- No. 1 Phillips Head Screwdriver
- No. 2 Flat Head Screwdriver
- No. 2 Phillips Head Screwdriver
- Marking Implement
- $\frac{3}{8}$ " Nut Driver Bit (with 1.5" min reach) or  $\frac{3}{8}$ " socket, extension and ratchet
- Concrete Drill Bits
- Temporary Power Means
- Precision Screwdriver Set
- Yellow / 74B wire Nut
- Anchors for Fixed Ramp (*if specified*)

### **RECOMMENDED TOOLS**

- Work Lights (Wired or Wireless)
- Fish Tape
- Ladder
- Steel Toe Shoes
- Safety Glasses
- First Aid Kit
- Box Cutter
- Hard Hat
- Shop Vacuum
- Shop Towels and General Purpose Cleaner

## PREPARATION

### BOX CONTENT

Inspect all of the boxes for damage or missing parts. If you see any damage contact the freight carrier to file a damage claim and contact Harmar.

Verify the products match those described on the packing list attached to the exterior packaging. If items are missing or are incorrect, contact Harmar.

### REQUIRED COMPONENTS NOT SUPPLIED

*NOTE: We recommend electrical supply to be installed by an electrician, per the NFPA 70.*

- Indoor applications use 30-AMP 120V 2-pole fusible & lockable disconnect. (NEMA 1) for outdoor applications use 30-AMP 120V 2-pole fusible & lockable disconnect (NEMA 3R).
- Wire, Conduit and Disconnect to meet NFPA 70 code
- Dedicated Electrical Lead (per local code)

### UNLOADING

- VPL units are shipped shrink wrapped to a pallet. Pallet dimensions will vary depending on the tower size. Units are screwed into the pallet, installers will require a 3/4" wrench socket to remove screws.

A lift gate is unable to be used on models 6' or taller which are shipped laying back. A pallet jack or forklift can be used to set into place.

*NOTE: Must have a loading dock, pick up the VPL at the shipping terminal, or ship it directly to the installation site. This information must be documented on the evaluation form.*

*NOTE: Enclosure panels and doors and or/top landing gate will be packed on a "A" frame skid.*

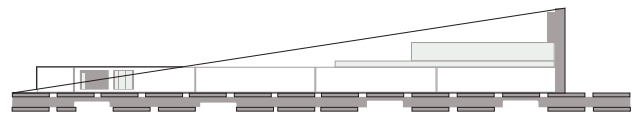
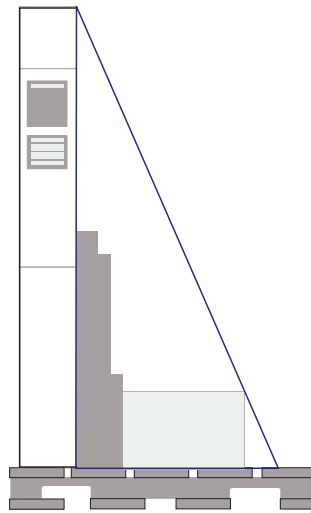

VPL's weigh between 800 - 1500 lb, depending on the height. The following may be necessary to assist in positioning:

- Additional Manpower
- Fork Lift
- Crane
- Pallet Jack
- Lever Bar Dolly

### UNPACKING

1. Unwrap the VPL and set the following items aside:
  - Small Parts Box
  - Ramp (if provided)
  - Platform Panels
  - Platform
  - Gate
2. Remove the tower from the pallet.
3. Perform pre-delivery inspection

**CONCRETE**

- Concrete pad should be no less than 4" thick, 3500 PSI reinforced, and must be level. The size of the concrete pad may vary depending on the size of the VPL footprint. Concrete at the bottom approach to the VPL must be large enough to turn a mobility device around. Pay close attention to the slope of existing concrete where the VPL is going to be installed. Existing concrete on the exterior of a house or building are normally sloped to shed water. The normal slope is about 1/8"-1/4" per foot to provide adequate drainage. Steel shims should be used to level the tower when the existing concrete has a normal slope. If the existing concrete has greater slope than 1/4" per foot, it should be reworked and leveled before installing the VPL.

 **CAUTION**

**Wood shims should never be used on either inside or outside applications.**

*NOTE: Do not shim more than 1/2".*

- Harmar recommends securing the lift using our Anchor Kit

**MATERIAL HANDLING**

 **CAUTION**

**Do not lift unit from bottom of the platform. This will cause damage to the safety systems.**

- It may be necessary to move the VPL around once it's on the job site. Extra material handling equipment such as manual carts, a pallet jack, fork lift, and/or crane may be needed. There may be times when VPL will have to be moved by man power. All of the tower panels can be removed to reduce the weight of the tower. Care should be taken not to scratch or damage panels when removing, carrying, and reinstalling them.

- Special care must be taken to protect any landscaping or flooring surfaces that might be damaged by the uses of material handling equipment.

**SITE PREPARATION**

- Review and confirm the power requirements for power supply and disconnect per NFPA 70.
- In preparation for receiving the lift for installation a final site inspection must be completed to ensure the mounting surface for the lift complies or exceeds Harmar's recommendation for the concrete slab. The size of the concrete slab must be large enough for the lift and the approach for the mobility device.
- If there was a blueprint created for the project check that all work matches the blueprint. Running clearance measurements should be double checked for the platform and fascia, guard panels and wall/barrier, and the platform top landing and overhead clearance. Ensure there are no pinch points.
- If doors are supplied by others check that they meet ASME A18.1, flush mount doors are required. If other non Harmar supplied equipment (power door openers, interlocks, and/or door strikes) are going to be used, check compatibility with Harmar equipment.
- The front tower panel and the top cover must be removed before any power, gate/door, call send connection can be made.

 **CAUTION**

**Make sure the assembly of the enclosure is level starting from the lower landing. Metal shims may be required. Squareness is required.**

# PREPARATION

## PLACING THE VPL

1. Depending on the height of the unit, it may be shipped horizontal. You will need to stand it up and place it where it will be fixed. If laying down, the tower is extremely heavy. Please take this into consideration when lifting the tower.

Be sure to lift from the frame if using machinery. DO NOT lift from the outside body panels.

Position the lift in place according to its dimensions. **See Figure 3-1.**

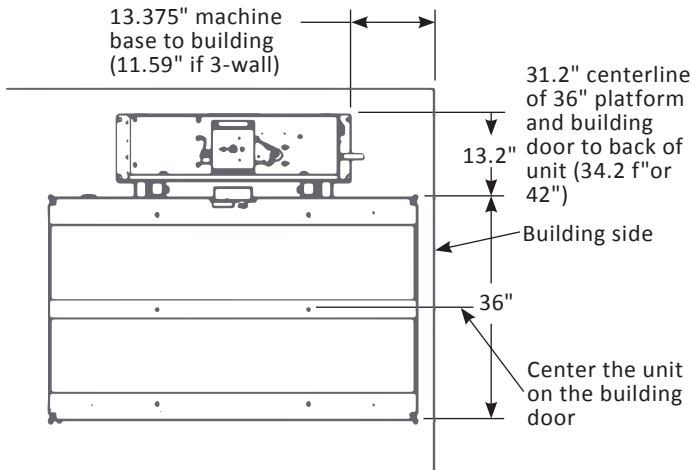

Figure 3-1

2. Install the tower-side walls that will potentially be against a structure onto the enclosure.

*NOTE: The bottom vent panel that has the large hole for the pit-switch will be on the other side of the tower.*

*NOTE: See the drawing of enclosed in the small parts of the enclosure.*

To install the panels, you will remove the screw that's in the tower and mount the side panel. **See Figure 3-2.**

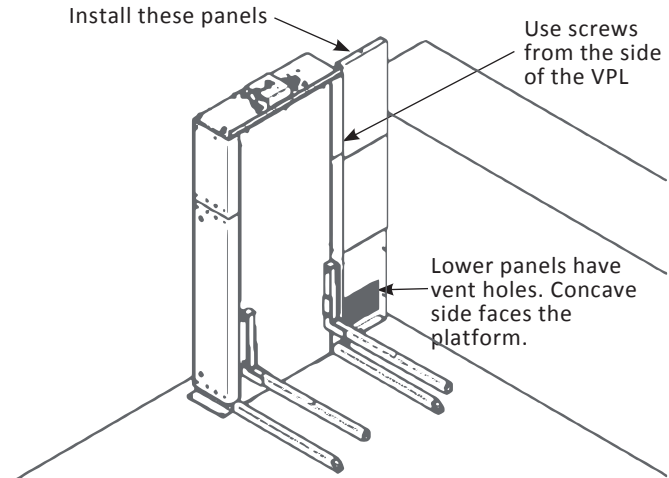

Figure 3-2

3. Un-pack the enclosure parts. If you've ordered an enclosure with acrylic windows, they'll arrive with a paper or plastic protector on all but the outside edges of the windows. You should leave these protectors on the windows until you are ready to finalize the installation. Be careful not to scratch the powder coat on any of the parts.

*NOTE: When building against a wall, you will have to access the components from the inside tower instead of the outside. The smooth side of all panels face to the inside of the unit.*

4. Put the enclosure alignment plate across the ends of the two tower legs. The plate is to ensure that you achieve the correct spacing of the vertical panels to the lift. **See Figure 3-3.**

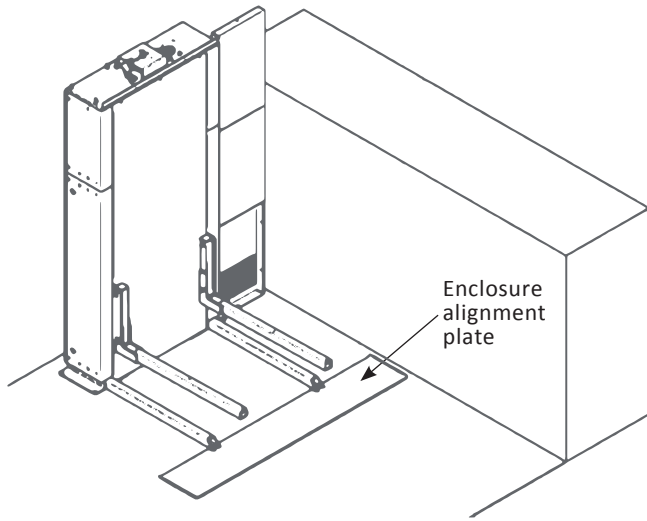

Figure 3-3

**NOTE:** Enclosure needs to have all screws and plastic washers secure to prevent rusting if the unit is located outside. After the unit is secured and anchored, the plate should be removed.

- Depending on the application, specifically if it is a wall side first, you may not have access to the bolt holes when it is assembled. Use the fastener kit specified on the installation drawing to assemble panels. **See Figure 3-4.**

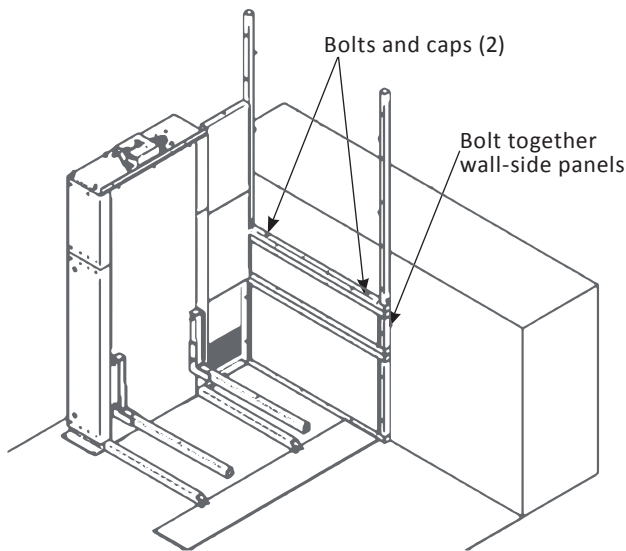

Figure 3-4

- Place the bolts through the tower side panels into the wall panels. **See Figure 3-5.**

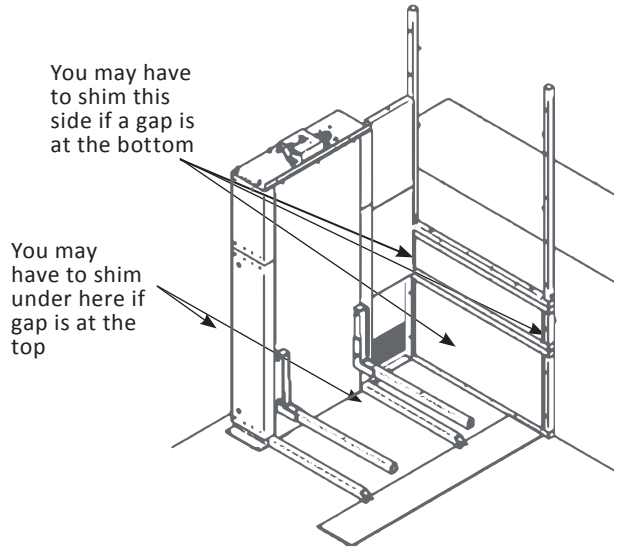

Figure 3-5

- Verify the spacing for the tower side panels and decide if you are going to need to shim the VPL unit. The tower side panels' edge needs to be parallel with the wall. Depending on the angle, if it is open at the bottom, shim the wall, if it is open at the top, shim the tower.

SECTION 4  
**INSTALLATION**

**NO HOISTWAY / NO FLOOR  
PENETRATION**

1. Remove 5X front screws.
2. Remove the plastic top cap by loosening the four (4) side screws and lifting the top cap. This part will be replaced by the Highlander II with enclosure metal top cap. *See Figure 4-1.*

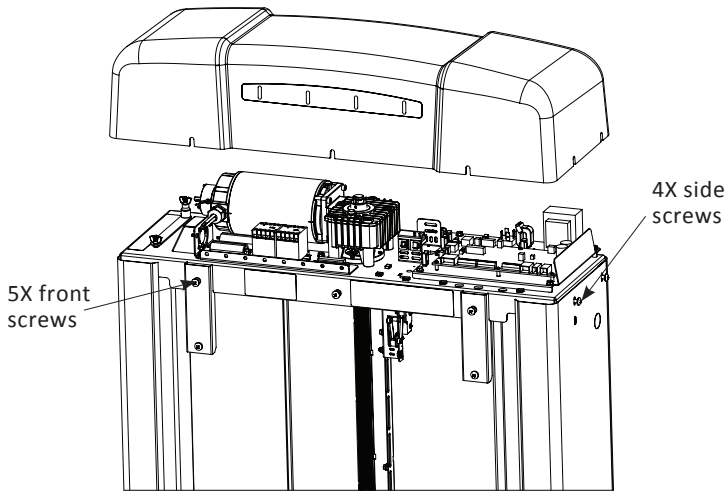

Figure 4-1

3. Remove the front panel by rotating it out slightly and lifting it out of the lower slots.
4. Position the VPL tower close to the upper landing and stand it up using appropriate material handling processes.

*NOTE: Tower frame should only be lifted by the rectangular tubes below the top plate.*

**ELECTRICAL CONNECTION**

**⚠ WARNING**

**Kill all power before making any electrical connections.**

1. Remove and discard the temporary bolt and nut ( $\frac{9}{16}$ " hex) that secures the tensioning pulley to the carriage for shipping. This bolt is indicated with a red tag. Suspend the pulley assembly behind the carriage. *See Figure 4-2.*

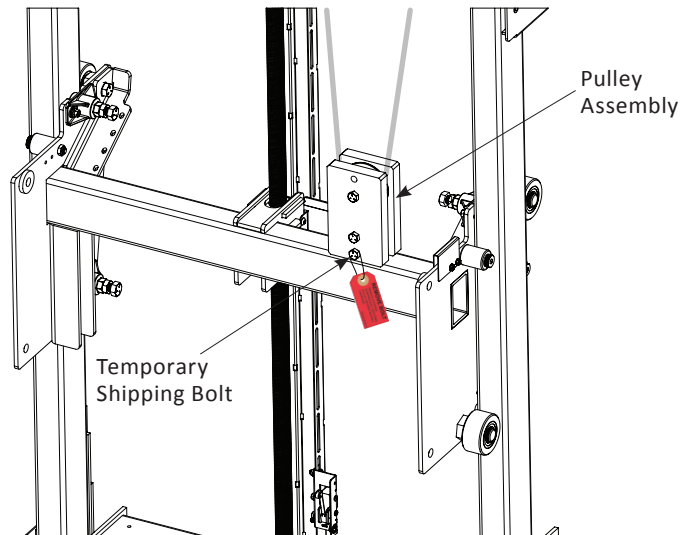

Figure 4-2

*NOTE: Be sure that the pulley assembly is suspended with the sheave at the top and that it is clear to move through the lift range.*

2. Connect the 8-pin platform control box connector.

**⚠ WARNING**

Verify that hot, neutral and ground conductors where the temporary power cord will connect are correct. Incorrect wiring or lack of ground could cause unit malfunction.

- Remove 4X screws on junction box cover inside the tower. Retrieve 4' temporary power cord from the parts kit. Route stripped end of wire into the junction box. *See Figure 4-3.*

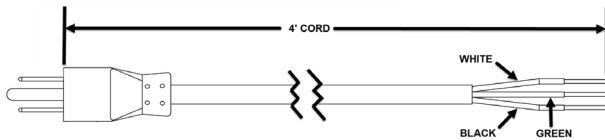

Figure 4-3

Make the following connections:

- Black to Black (L1 Hot)
- White to White (L2 Neutral)
- Green to Green (Ground)

If a battery backup is included, there will also be two (2) brown wires in the junction box. The two (2) brown wires get tied to each other. *See Figure 4-4.*

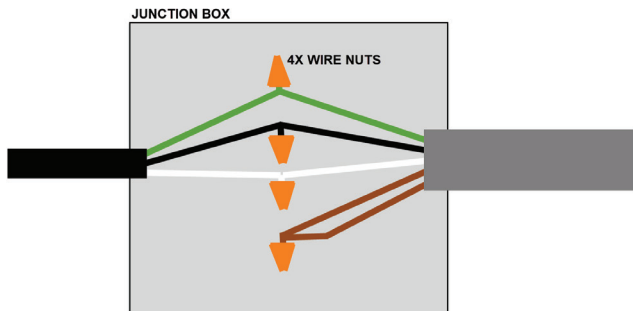

Figure 4-4

**⚠ WARNING**

Brown wires are the disconnect for the battery backup output. As long as brown wires are tied together, the inverter will not be disconnected during service.

- Connect a temporary cord to a grounded 20A extension cord and route down through the back of the center wire channel to the bottom of the lift and out to a temporary 120V AC outlet. *See Figure 4-5.*

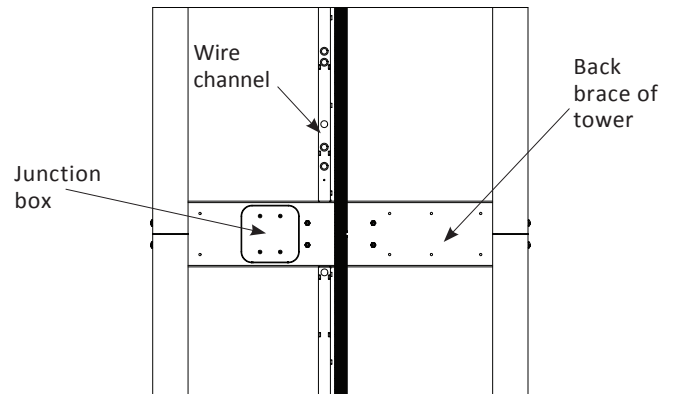

Figure 4-5

- Once power is established and the VPL comes online, the indicator LED's on the control board will flash an alarm code to indicate that the installation is incomplete.

# INSTALLATION

## BATTERY BACKUP

1. If equipped with a battery backup system. Place two or four batteries on the battery tray(s) and connect spade terminals to the batteries.

### NOTICE

Refer to wiring schematic 640-00025 for connectivity and polarity.

*NOTE: Inverter comes switched off to conserve battery power. Please switch the inverter to on.*

2. If equipped with a cold-weather package, the junction box will include a duplex outlet.
  - Install thermostatic switch into the top outlet.
  - Wrap battery warming blanket around each pair of blankets with the overlap and cord in the back.
  - Feed the blanket cord down behind the battery tray and plug into the thermostatic switch.
  - Wrap 2X zip-ties around the outside perimeter of the batteries.  
DO NOT OVER-TIGHTEN.

## PLATFORM CONNECTION

1. Place the platform on a support object strong enough to handle the weight of the platform. Position the platform on the support located near the bottom of the VPL.
2. Press the service button on the control electronics board. All four (4) status indicator LED's will flash green, to show that "Service Mode" is active. The unit will remain in "Service Mode" for ten minutes. Press the service button again if needed.
3. Use the platform control box to move the carriage up or down to align the platform and carriage mounting holes. **See Figure 4-6.**



Figure 4-6

4. Install the four (4) 1/2" bolts using the low profile Nyloc nuts on the lower bolts and a standard nyloc nut on the upper bolts. **See Figure 4-7.**



Figure 4-7

5. Secure the safety pan harness and platform control harness under the clip at the top of the carriage flange.

## INSTALLING A 90° PLATFORM (IF NECESSARY)

If installing a 90° platform, please follow the approved drawings for your application.

The panels are different to accommodate the application. *See Figure 4-8.*

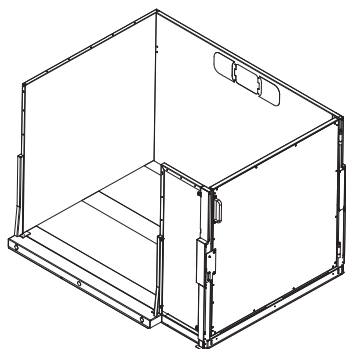

Figure 4-8

## INSTALLING THE PLATFORM CONTROL GUARD PANEL

1. Locate hardware packs for platform in small parts bags.
2. Insert the control side guard panel posts into the pockets on the platform with the smooth side facing the inside of the platform. Fasten in place with four (4) ¼"- 20 x 2" bolts. Torque bolts down sufficiently to hold guard panels rigidly in-place. The platform material in front of the pockets may deform slightly while tightening bolts.
3. Remove the four (4) screws and nuts loosely attached to the control box.
4. Fasten the control box to the control guard panel securely with the four (4) screws and nuts. Connect the ground ring terminal to the bottom screw connecting the control box to the panel.

## INSTALLING THE PLATFORM FRONT GUARD PANEL

Insert the front guard panel posts into the pockets on the platform with the smooth side facing the inside of the platform. Fasten in place with four (4) ¼"-20 x 2" bolts.

## WEATHERIZING THE ENCLOSURE

During the assembly of the enclosure, apply a bead of silicone sealant between all mating surfaces of the enclosure panels, window trim retainer, and tower panels. *See Figure 4-9.*



Figure 4-9

## INSTALLING ENCLOSURE TOWER WALLS

Your enclosed Highlander II will come with a CAD certified drawing that was approved by Harmar and the customer. It will show how the unit should be fixed and what hardware should be used.

1. Place and shim (if necessary) the lowest front wall, the door frame and the tower-side walls on the door-side of the enclosure. The lowest tower side-panel is vented and is placed with the vent side against the back of the tower. This side is intentionally left spaced for the emergency pit-switch. Assemble and install the pit-switch and its housing box.

**See Figure 4-10.**

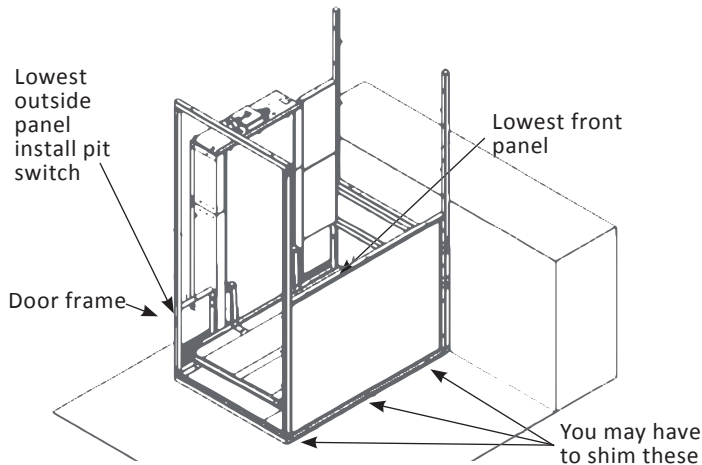

Figure 4-10

2. Install the rest of the front and tower-side panels, by stacking them one on top of each other per the provided CAD drawing.

These panels bolt together with Allen head bolts and nyloc nuts. Some panels are threaded and others will require you to use a metal cylinder spacer.

After all panels are assembled you are now able to place the top cap. For lifts taller than

8', you may skip ahead to the anchor step on page 23. **See Figure 4-11.**

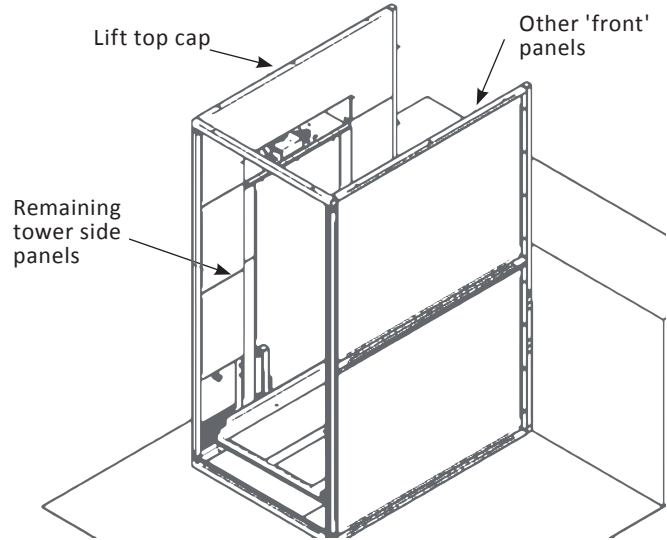

Figure 4-11

3. Your door may come assembled to the frame. The door assembly weighs more than 200 lb, so take care in lifting it into place and be careful not to scratch it. Put eight bolts into it and leave them loose before final placement. You'll need to adjust the position both vertically and horizontally to match the threshold of the ramp (or upper landing). **See Figures 4-12 and 4-13.**

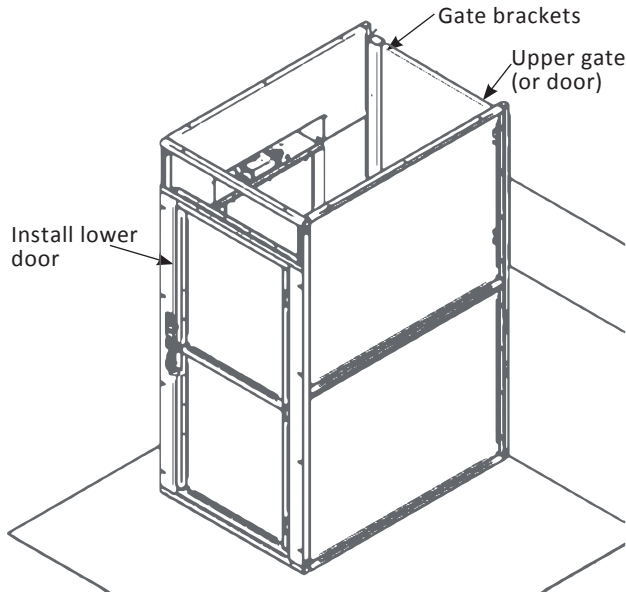

Figure 4-12

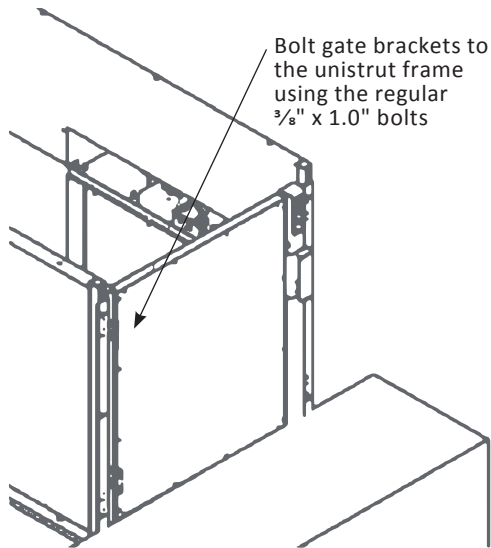

Figure 4-13

**NOTE:** Ensure all bolts inside of the hoistway are cap-head side to prevent pinch/injury.

**NOTE:** Do not completely secure hardware until final alignment is verified.

- Whether the enclosure uses a fixed ramp or you have a pit, the next step is to adjust the height of the doors to fit their thresholds. Pry them gently to the correct height with a piece of wood to prevent damaging the finish. In order to set the height correctly, you may need to adjust the lower and upper stops on the lift to have it stop correctly on the landings.

Limit switches are housed inside of the tower and are visible with the front panel removed. They can be adjusted UP or DOWN on a slotted channel with Allen bolts holding them in place.

**WARNING**

**Turn power off if an adjustment is required.**

- Use the provided plexiglass above the door. Install the acrylic with the angles and flats provided, which rivet in. *See Figure 4-14.*

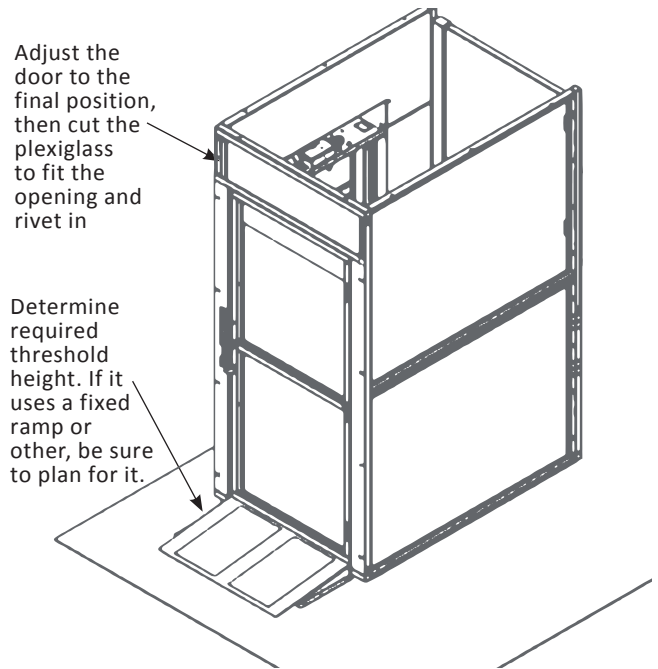

Figure 4-14

# INSTALLATION

- Adhere the Z97.1 labels on plexiglass after installation.

*NOTE: Note: Plexiglass comes cut to spec. Trim will be provided to hold plexi in place, however it will need to be riveted to secure. See Figure 4-15.*



Figure 4-15

*NOTE: Depending on the platform application you may need to verify spacing around the platform to ensure a clear path of travel.*

- If the unit is equipped with a ventilation system, power will need to be supplied separately from the VPL unit. The ventilation system is DC power operated but requires an AC power supplemental charge.

*NOTE: The ventilation system comes installed with a thermostat. The thermostat is preset to meet ASME A18.1 set the temperature under rule 2.1.1.8 (temperature not to exceed 32° C or 90° F).*

## INSTALLING THE DOME

- The top panels of the enclosure will have a slotted bracket installed between the panel and the dome.

The dome has threaded attachment points that rest inside of the slots and a nut that is attached for securement. **See Figure 4-16.**



Figure 4-16

## INSTALLING THE TOP LANDING GATE (IF NECESSARY)

*NOTE: If the call send switch is installed in the gate, the wires are routed between the gate and to the top of the tower. If the call send is located outside the gate, the wires are routed from the gate to the call send box and then from the box to the top of the tower.*

- Create the necessary space below the gate sill so the wire can be routed into the gate post through the wire routing slot. **See Figure 4-17.**

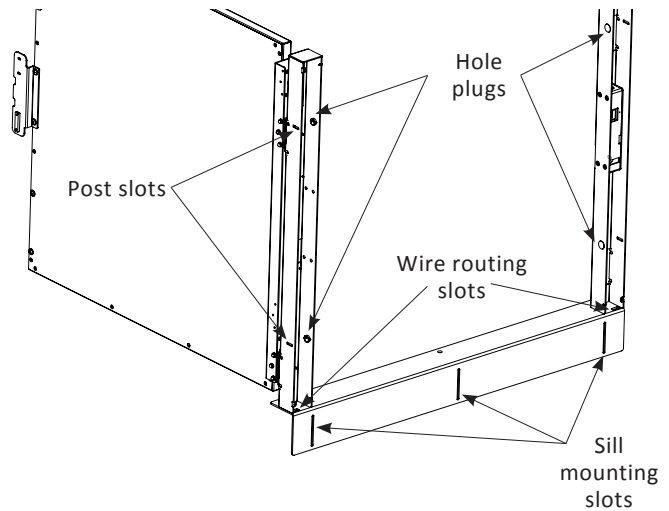

Figure 4-17

- Remove small screws and post cover on the latch side of the landing gate with a No. 1 Phillips screwdriver.
- Open landing gate door and remove 4X hole plugs.
- Place the gate at the upper landing and center the gate opening with the platform.
- Use the holes in the gate threshold to screw the gate down to the landing.
- Run the wire through the wire routing slot and to the interlock.



# INSTALLATION

## CALL STATIONS

Check your state and local codes (ASME A18.1 height to mount call-stations, 15" to 48" off the floor surface of landing) for mounting height locations for the call stations.

Call stations can be mounted on a surface or flush-mounted on a 2-gang outlet box.

1. Remove four (4) label plate screws and label plate. *See Figure 4-20.*

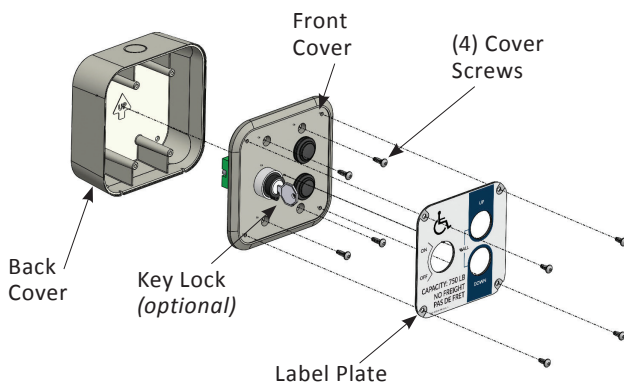

Figure 4-20

2. Remove four (4) cover screws and the front cover from the back cover.
3. Landing wires are pre-wired to the control board as shown in Figure 4-7. Retrieve wires that are coiled up inside the tower and determine the routing of wires going to the call station. Verify applicable code requirements.
4. If using the back cover for a wall mount setup, cut out the desired knock-out for wire routing. There are four (4) knockouts on the back cover. Two (2) on the back surface, one (1) on the top and one (1) on the bottom.
5. If using a flush-mounted setup the back cover can be discarded.

6. Mount back cover to the wall using appropriate fasteners through four (4) holes in the back surface of the back cover.
7. If using an interlock or strike with doors by others, insert a 6-conductor cable into one back cover through one of the knockouts.
8. Use crimp connectors to make cable connections in the call station. *See Figure 4-18.*
9. Install the front cover to back cover or in-wall outlet box with four (4) cover screws.
10. Install label plate on the front cover with four (4) label plate screws.
11. If the routing of the wires changes, be sure to zip tie them out of the way of moving parts (ex. Carriage rollers).

## DOORS BY OTHERS

Interlocks and Strikes to be installed into doors by others are shipped with VPL in the OEM packaging.

Install devices per instructions in the packaging.

Connect wiring per device instructions and Figures 4-17 on page 21. For details, please refer to the supplemental guide "Highlander II Wiring Schematics".

*NOTE: A wiring diagram with part number 640-00025 is placed in a packet with your shipment.*

*NOTE: Von Duprin strikes are not compatible with lifts containing a Battery backup option.*

## FINAL POSITIONING AND ANCHORING

79" of overhead clearance is required above the platform floor when the lift is at the upper landing.

Position the lift in its final location.

Verify that the tower front and sides are plumb and all running clearances are the proper dimensions. Shim if necessary. **Wood shims must never be used.**

Install two (2) anchors at the back of the tower and two (2) anchors into the tower legs. *See figure 4-21.*

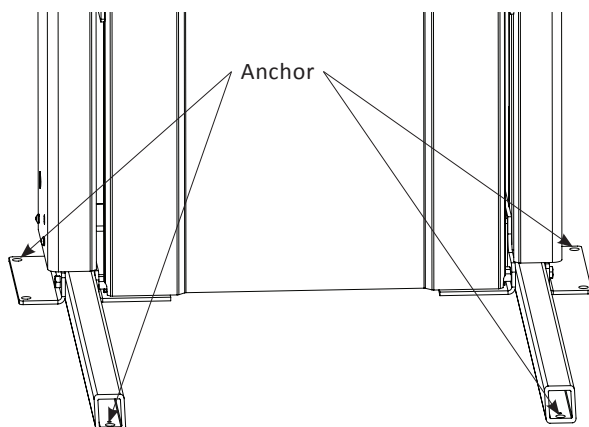

Figure 4-21

1. 8' models must have the lift tower anchored into a solid surface at or above the top cross-brace of the tower frame. 10' or taller models must have the lift tower anchored at two (2) levels into a solid surface at or above the top two (2) tower cross braces. This is to ensure running clearances remain constant. There are two (2) spacers included in the small parts kit that go between the cross brace and back panel to provide a more secure connection to wall. There are two options for anchoring the top of the tower. *See Figure 4-22.*

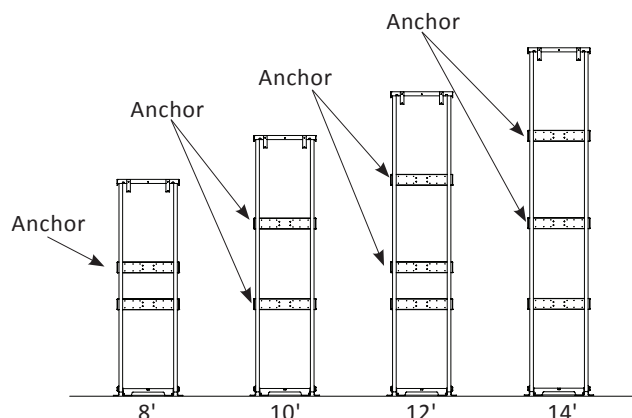

Figure 4-22

The first option is to use the optional tower brace that attaches to the sides of the tower. Some brackets attach to a structure. Then the brackets are fastened together.

### NOTICE

*Locate the tower brace as high as possible on the tower.*

The second option for anchoring the lift is drilling through the slots in the back of the tower cross-braces at the desired locations and anchor to the structure behind the lift. The wall needs a brace or a solid structure behind it. Anchors should be built out at least 1" from the center 15" of the tower back so that top can be removed for service. Insert supplied spacers behind tower cross braces when anchoring.

## INSTALLING FIXED RAMPS

1. Position ramp  $\frac{3}{8}$ " to  $\frac{3}{4}$ " from the platform door frame at the lower landing.
2. Anchor the ramp to the concrete pad.

# INSTALLATION

## INSTALLATION TOWER CHECK

Before reinstalling the top cap and front panels, an operational check should be completed on the internal tower safety features.

- Apply temporary power and verify all four (4) LED indicator lights on the control board are solid green.

---

- Manually depress the final limit switch (the highest positioned switch) and verify any travel of platform is prevented and indicator lights 1, 2, and 3 are flashing RED.

---

- Manually depress the safety nut switch (the switch near ACME nut) and verify any travel of platform is prevented and indicator lights 1, 2, 3, and 4 are flashing RED.

---

- Manually depress the Over-Speed Governor (OSG) switch (the switch at the bottom of ACME screw) and verify any travel of platform is prevented and indicator lights 1, 2, and 3 are solid RED.

---

- If equipped, lift the float of the float switch (the switch at the bottom of the tower) and verify that DOWN travel is prevented and indicator light two (2) is flashing AMBER.

---

- Verify that the ACME drive screw is lubricated.

---

- Verify that the shipping bolt was removed from the cable tensioning pulley and that the pulley is hanging in the tower without hitting any obstacles during platform travel.

---

- Verify that the manual lowering wrench and socket are located in a secure place outside the lift.

---

- Verify that the E-Stop is functional and all 4-LED lights are solid red with no lift movement.

---

- Verify the screws securing the tower skins have a plastic washer and are tight.

---

Reset the board

- Enter service mode by pressing and releasing the service button
  - Press and hold down the service button again for 3-seconds.
  - Press and release the reset button.
- 

## FINAL INSTALLATION

Completing the above steps will clear any errors from the board.

1. Install the front panel between the platform and tower. Slots in the bottom of the front panel should rest on the pins in the tower. Install five (5) ¼"-20 screws and plastic washers at the top front panel leaving the top three (3) screws loose and ¼" offset from the panel.
2. Disconnect the power to the lift. Connect the cable in the top cap for status indicator lights into the control board. Slide the top cap over the top of the tower aligning the top cap slots with the four (4) side screws and three (3) front screws. There are tabs in the back of the top cap that drop into slots in the tower top plate. These tabs must drop into the slots for the top cap to sit down on all seven (7) screws. Tighten seven (7) ¼"-20 screws securely against the top cap. Reconnect the power to the lift.
3. If the unit is outside, Harmar recommends (weatherizing) the Highlander II with enclosure unit. This will consist of caulking silicone between the enclosure panels. This will prevent ice/water from penetrating the area between the panels to help prevent rusting.

## OPERATIONAL CHECK

Upon installation and at scheduled intervals the operation of the VPL must be verified.

*NOTE: ASME A18.1-2017 requires that when the lift is installed in commercial applications, operation checks are to be conducted not less than weekly by authorized personnel.*

- Apply power and verify all four (4) LED indicator lights are solid green.

---

- Paddle/buttons on cab controls control UP and DOWN travel.

---

- E-Stop PRESSED IN stops and prevents travel of platform. Button illuminates and alarm sounds (if equipped). Indicator lights 1, 2, 3 and four (4) are solid RED.

---

- Key switch (if equipped) OFF stops and prevents travel.

---

- Landing switches stop the platform at each landing within 1/2", does not coast, and opens the gate locks.

---

- Automatic Door Openers (if equipped) open the doors/gates at landing.

---

- Open doors/gates prevent any travel of the platform. Indicator lights three (3) and four (4) are solid RED.

---

- Call Station buttons control UP and DOWN travel.

---

- Key switch (if equipped) OFF on Call Stations stops and prevents travel from Call Station.

---

- If equipped - safety pan switches depressed prevent DOWN travel and allow UP travel (check several locations). Indicator lights one (1) and (2) are flashing AMBER.

---

- Pit switch (if equipped) prevents UP and DOWN travel. Indicator lights 1, 2, and 3 are solid RED.

---

- Verify that the ventilation system/lighting is functional and charging.

## PERMANENT POWER INSTALLATION

Permanent power can be installed at various points in the overall installation process; however, it must be installed by a qualified electrical contractor in compliance with local codes and regulations. The VPL must be wired to a dedicated circuit, connected through a 2-pole fused and lockable disconnect, providing a 120V AC power supply (15 Amp breaker). The fuses should be a minimum of 15A.

**See Figure 4-23.**

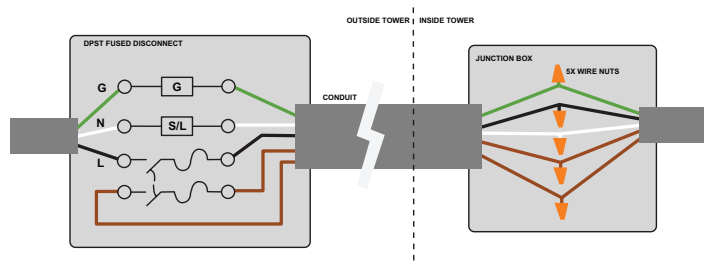

Figure 4-23

Route wiring from disconnect to tower as directly as possible and enter the tower through most convenient knock-out in the tower side panels. Inside the tower enclosure, route wires from knockout to internal junction box along the back panel of the enclosure. Use the backside of the wire channel if the junction box is at a different level than knockout. Be sure all wiring is routed clear of the moving carriage and roller wheels inside the tower. **See Figure 4-24.**

# INSTALLATION

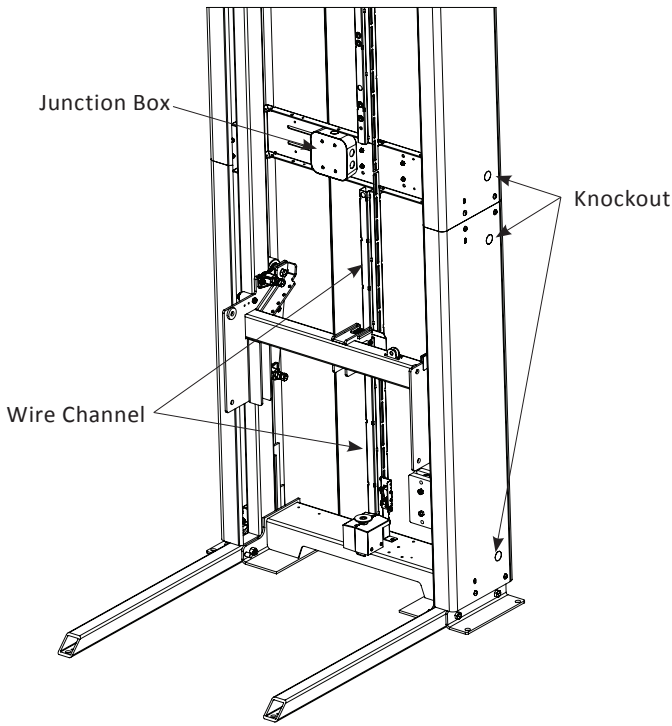

Figure 4-24

## OPERATOR FAMILIARIZATION

Upon completion of the installation, it is imperative to review all contents of the Owner’s Manual with the customer and provide a thorough demonstration and familiarization of the lift.

In residential applications, this should be conducted with the end-user and any or all of the following: the homeowner, family members, caregiver, etc. You should not leave until the end-user or primary lift operator has demonstrated they can use the lift properly.

In commercial applications, this would take place with any or all of the following: the property owner, facilities manager, or any personnel who may oversee the unit’s use or control its access.

### PROVIDE OVERVIEW

- Review all warnings
- Describe how the lift works and familiarize with key components
- Pre-use inspection

### DESCRIBE AND DEMONSTRATE PROPER USE AND EACH KEY

- Call/Send
- Entrance and positioning
- Door/Gate interlocks and safety pan
- Status lights and color key
- Ascend/Descend
- Use of handrail (*if equipped*)
- Emergency lowering

### REVIEW CARE AND MAINTENANCE

- Keys
- Maintenance items
- Inspection items
- Rust prevention

Be sure to leave them with the Owner’s Manual and that your contact information has been written into it as well as on the labels in the cab and on the tower. **Have them complete the Warranty Registration while you are there.**

## SECTION 5

# INSTALLATION QUICK START

### SITE PREP

- Code Compliance
- Upper Landing
- Foundation Level
- Hoistway Square
- Electrical

*Code: ASME 18.1 relative to residential or commercial, NAEC and Local Building; NFPA 70 (electrical code).*

### POSITION LIFT BENEATH LANDING

- Remove Top Cap
- Remove Front Panel
- Verify Overhead Clearance at 79" min

*TIP: Use material handling equipment with lifting straps to avoid injury/damage.*

### ASSEMBLE PLATFORM

- Attach Platform to Carriage
- Bolt on Side Walls
- Attach and Wire Control Panel

*Tip: Use 2'x4' beneath platform base when connecting to carriage.*

### FINAL POSITIONING & ANCHORING

- Level and Perpendicular
- Anchor Tower Legs
- Anchor Tower to Structure
- Fixed Ramp Securement\*

### VERIFY CLEARANCES:

- Platform opening to landing:  $\frac{3}{8}$ " -  $\frac{3}{4}$ "
- Guard panel to hoistway wall: 2" - 3"

### WIRING & ELECTRICAL

- Gates\*/Doors/Interlocks/Openers
- Call/Sends\*
- Install and Connect Battery Backup\*
- Dedicated Line to Primary Power Source

*TIP: Use knockouts provided along tower to minimize wire distance.*

### FINAL

- Perform Final Function Tests
- Insert permanent power installation
- Reattach Top Cap Panel and Front Cover
- Operator Familiarization
- Complete Warranty Form
- Write Date/Info on Lift

*\* If required/included*

# TROUBLESHOOTING

## SECTION 6

# TROUBLESHOOTING

## STATUS CODES

This lift has several advanced safety systems that monitor various sensors, switches and the performance of the lift. To indicate the status of the VPL there are 4-LEDs located on the Top Cap of the tower. The table below explains the status indicated by the 4-LEDs. LEDs are numbered from left to right, while facing the tower from the platform side. Color listed in brackets indicates LED is flashing.

See Figure 6-1.

NOTE: [COLOR] means flashing light.

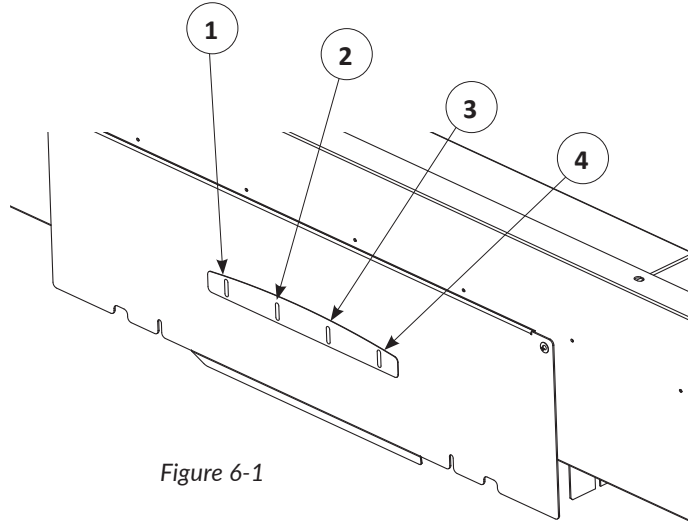

Figure 6-1

STATUS LED				STATUS
#1	#2	#3	#4	
All OFF				<b>Lift will not function.</b> Major Fault, No Power (and no battery) or Low Power Mode. Service is Required.
Any Green or [Green]				<b>Lift functional.</b> No faults
Green	Green	Green	Green	<b>All systems normal.</b> Lift is OK to Operate.
[Green]	[Green]	[Green]	[Green]	<b>Lift is in "Service Mode".</b> Only Authorized Technicians should Operate.
[Green]	[Green]	[Green]		<b>Lift is running on backup power.</b> Lift is OK to Operate.
Any Amber				<b>Lift is OK to Operate.</b> Service is Required.
Amber	Amber	Amber		<b>Lift is running on backup power and battery is Low.</b> Lift is OK to Operate for at least one full lift cycle.
	Amber	Amber	Amber	<b>Lift is on AC power and battery is Low.</b> If lift transfers to backup power it will only operate for at least one full lift cycle. Service or replace batteries.

# HIGHLANDER II WITH ENCLOSURE: SECTION 6 TROUBLESHOOTING

STATUS LED				STATUS
#1	#2	#3	#4	
Amber				<b>Service is required.</b> Flood Switch was activated.
	Amber			<b>Service is required.</b> Lift travel time exceeded average.
Amber	Amber			<b>Service is required.</b> Periodic maintenance limit reached.
		Amber		<b>Service is required.</b> Service hour limit reached.
Any [Amber]				<b>Minor fault. Platform function is reduced.</b> Service may be Required.
[Amber]	[Amber]	[Amber]		<b>Lift is running on backup power and battery is very low.</b> Platform will only go down.
	[Amber]	[Amber]	[Amber]	<b>Lift is on AC power and battery is very low.</b> If lift transfers to backup power platform will only go down. Service is Required*.
		[Amber]		<b>Motor temperature is hot.</b> Platform will only go down.
[Amber]			[Amber]	<b>Motor is drawing too much current.</b> Platform will only go down. Service is required.
[Amber]	[Amber]			<b>Safety pan has been triggered.</b> Platform will only go up.
	[Amber]			<b>Float switch has been triggered.</b> Platform will only go up. Service will be required to ensure safe operation. Alarm will turn into a Major Fault after 25 full cycles or two (2) weeks time after flood event.
	[Amber]	[Amber]		<b>Motor temperature monitoring lost.</b> Service is required.
Any Red				<b>Safety switch triggered.</b> Lift will not function.
		Red	Red	<b>A landing door/gate is open.</b> Lift will not function until closed.
Red	Red			<b>A landing door/gate lock has failed.</b> Lift will not function until lock is enabled. Service may be required.
Red	Red	Red	Red	<b>E-Stop button is pressed.</b> Lift will not function until button released.

*\*If battery is not replaced promptly after this warning, the battery will further degrade to the point that unit will shut off completely when AC power is lost.*

# TROUBLESHOOTING

STATUS LED				STATUS
#1	#2	#3	#4	
Red	Red	Red		<b>Pit switch or OSG triggered.</b> If pit switch, lift will not function until switch changes state. Service is required if it is the OSG switch.
Any [Red]				<b>Lift will not function.</b> Major Fault. Service is required.
	[Red]			<b>Lift out of service.</b> Service is required after a flood event.
	[Red]	[Red]	[Red]	<b>Lift out of service.</b> Service is required for periodic maintenance.
[Red]				<b>Lift out of service.</b> Lift travel time exceeded average by 2X. Service is required.
[Red]	[Red]	[Red]	[Red]	<b>Lift out of service.</b> Safety nut switch is triggered. Service is required.
[Red]	[Red]	[Red]		<b>Lift out of service.</b> Final limit switch is triggered. Service is required.
		[Red]		<b>Lift out of service.</b> Top landing switch did not change state when platform should have moved off landing. Service is required.
	[Red]	[Red]		<b>Lift out of service.</b> Mid landing switch did not change state when platform should have moved off landing. Service is required.
[Red]		[Red]		<b>Lift out of service.</b> Bottom landing switch did not change state when platform should have moved off landing. Service is required.
		[Red]	[Red]	<b>Lift out of service.</b> Motor current is 0 Amps while going up. Service is required.
			[Red]	<b>Lift temporarily out of service.</b> Motor temperature is Very Hot. Lift will not function until the motor has cooled.

*\*If battery is not replaced promptly after this warning, the battery will further degrade to the point that unit will shut off completely when AC power is lost.*



# TROUBLESHOOTING

## CONTROL BOARD

The Control Board contains the processor, receives all of the sensor input, sends out all of the commands and provides important feedback for troubleshooting. It identifies each of the inputs and outputs on the Control Board. *See Figure 6-3.*

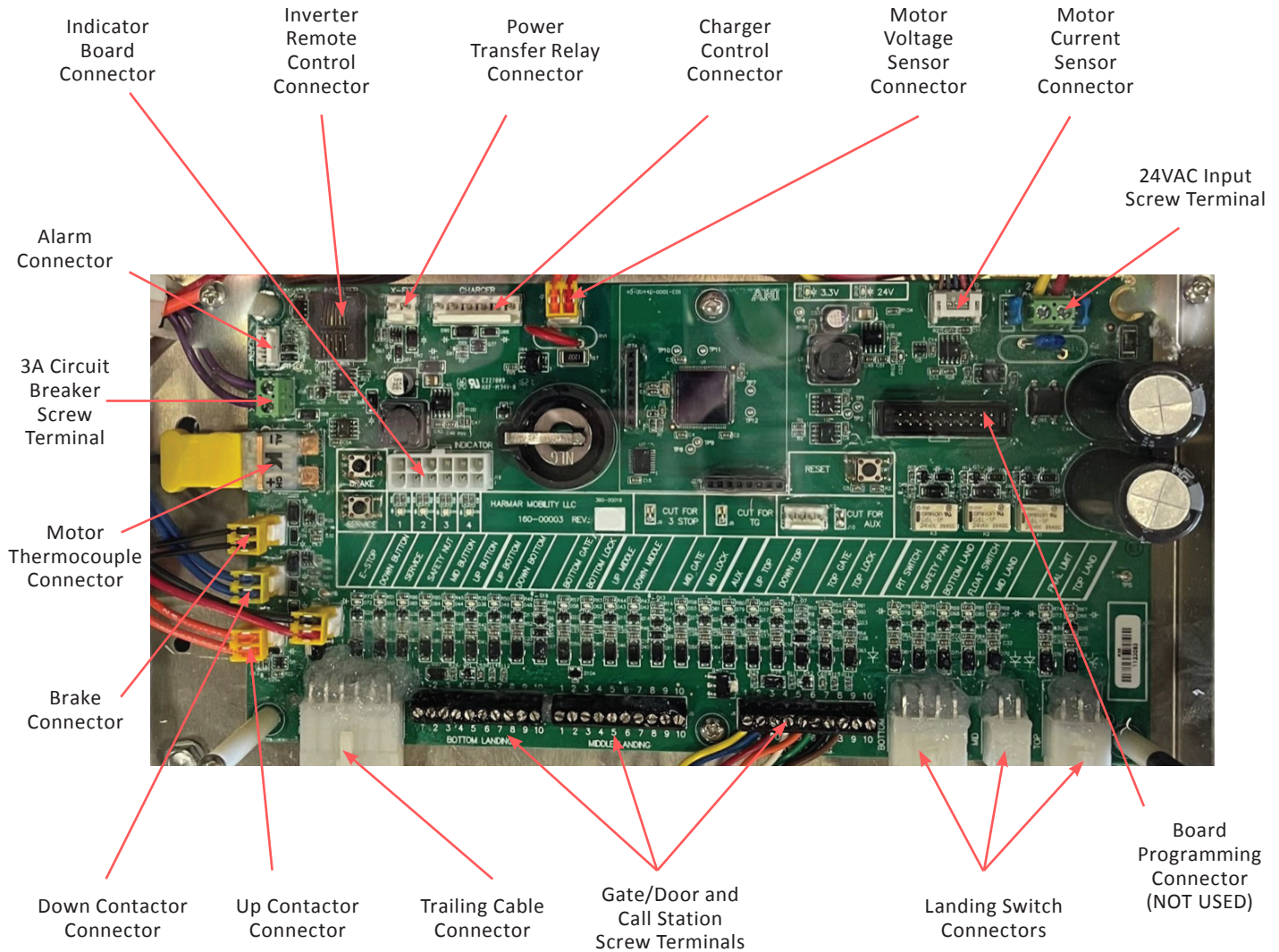

Figure 6-3

The control board has 32 LEDs to provide the status of power to the board and each circuit that is monitored. It shows the location and description of each LED. *See Figure 6-4.*

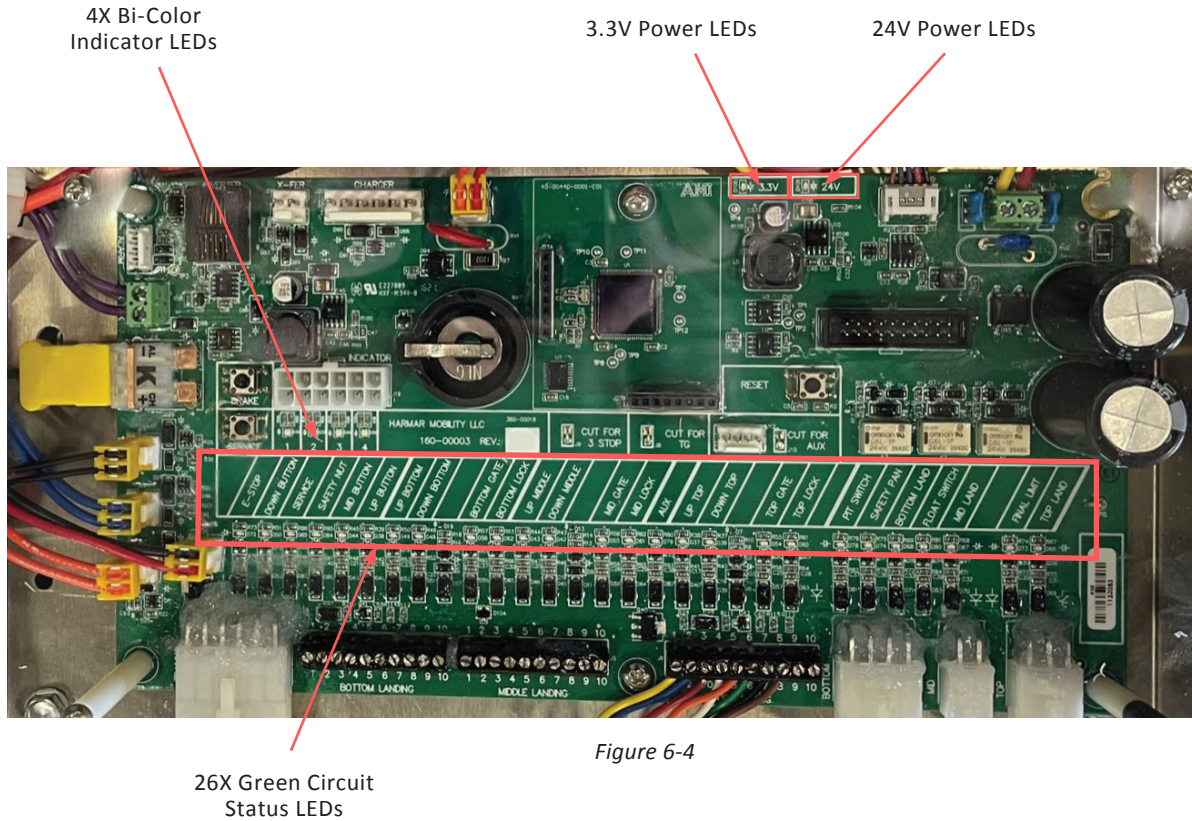

Figure 6-4

DESCRIPTION	COLORS	STATUS, TROUBLESHOOTING
<b>4X Indicators</b>	Green, Amber, Red	These LEDs exactly duplicate the Indicator LEDs on Top Cap. If they do not match there could be an issue with cable or Indicator Board. Refer to Troubleshooting codes above.
<b>3.3V Power</b>	Green	LED ON indicates processor is getting power.
<b>24V Power</b>	Green	LED ON indicates all 24V circuits are getting power.
<b>E-Stop</b>	Green	LED ON indicates the E-stop is not depressed (lift can run)

# TROUBLESHOOTING

<b>Down Button</b>	Green	LED ON indicates the Down button in the cab control is being depressed.
<b>Service</b>	Green	LED ON indicates the Service button is being depressed. Service mode is only entered after button is released.
<b>Safety Nut</b>	Green	LED OFF indicates the safety nut switch circuit is open. Major Fault. Possible causes: ACME nut failure, switch failure, connector open or wire break.
<b>Mid Button</b>	Green	If a 3-Stop unit, LED ON indicates the Mid button in the cab control is being depressed. This should never be ON with a 2-stop lift.
<b>Up Button</b>	Green	LED ON indicates the Up button in the cab control is being depressed.
<b>Up Bottom</b>	Green	LED ON indicates the Up button in the Bottom Call Station is being depressed.
<b>Down Bottom</b>	Green	LED ON indicates the Down button in the Bottom Call Station is being depressed.
<b>Bottom Gate</b>	Green	LED ON indicates the Bottom or Platform Gate/Door interlock is closed.
<b>Bottom Lock</b>	Green	LED ON indicates the Bottom or Platform Gate/Door lock is active.
<b>Up Mid</b>	Green	LED ON indicates the Up button in the Mid Call Station is being depressed.
<b>Down Mid</b>	Green	LED ON indicates the Down button in the Mid Call Station is being depressed.
<b>Aux</b>	Green	Aux circuit is unused
<b>Mid Gate</b>	Green	LED ON indicates the Mid Gate/Door interlock is closed.
<b>Mid Lock</b>	Green	LED ON indicates the Mid Gate/Door lock is active.
<b>Up Top</b>	Green	LED ON indicates the Up button in the Top Call Station is being depressed.
<b>Down Top</b>	Green	LED ON indicates the Down button in the Top Call Station is being depressed.
<b>Top Gate</b>	Green	LED ON indicates the Top Gate/Door interlock is closed.

# TROUBLESHOOTING

<b>Top Lock</b>	Green	LED ON indicates the Top Gate/Door lock is active.
<b>Pit Switch (if equipped)</b>	Green	LED OFF indicates the Pit Switch (if equipped) or Over Speed Governor circuit is open. Major Fault. Pit switch and OSG share a circuit that normally closed. Possible causes: Failure causing drive screw overspeed, switch failure, connector open or wire break.
<b>Safety Pan (if equipped)</b>	Green	LED OFF indicates the safety pan circuit is open. Minor Fault. Platform is only able to move up. If circuit stays open after obstruction cleared there could be a switch failure, connector open or wire break. There are 11 safety pan switches in platform.
<b>Bottom Land</b>	Green	LED ON indicates the Bottom Landing switch is closed. The switch should be closed only when platform is at that landing.
<b>Float Switch (if equipped)</b>	Green	LED ON indicates the float switch (if equipped) is closed. Minor Fault. The platform is only able to move up. The switch should be closed only when water is present and lifting the float.
<b>Mid Land</b>	Green	If a 3-Stop lift, LED ON indicates the Mid Landing switch is closed. The switch should be closed only when platform is at that landing.
<b>Final Limit</b>	Green	LED ON indicates the Top Final Limit switch is closed. Major Fault. The Top Landing switch did not close when platform was at that landing. Possible causes: Top Landing switch failure, connector open or wire break.
<b>Top Land</b>	Green	LED ON indicates the Top Landing switch is closed. The switch should be closed only when platform is at that landing.

# TROUBLESHOOTING

The control board has three (3) momentary switches and three (3) permanent cuttable switches/jumpers. See Figure 6-5.

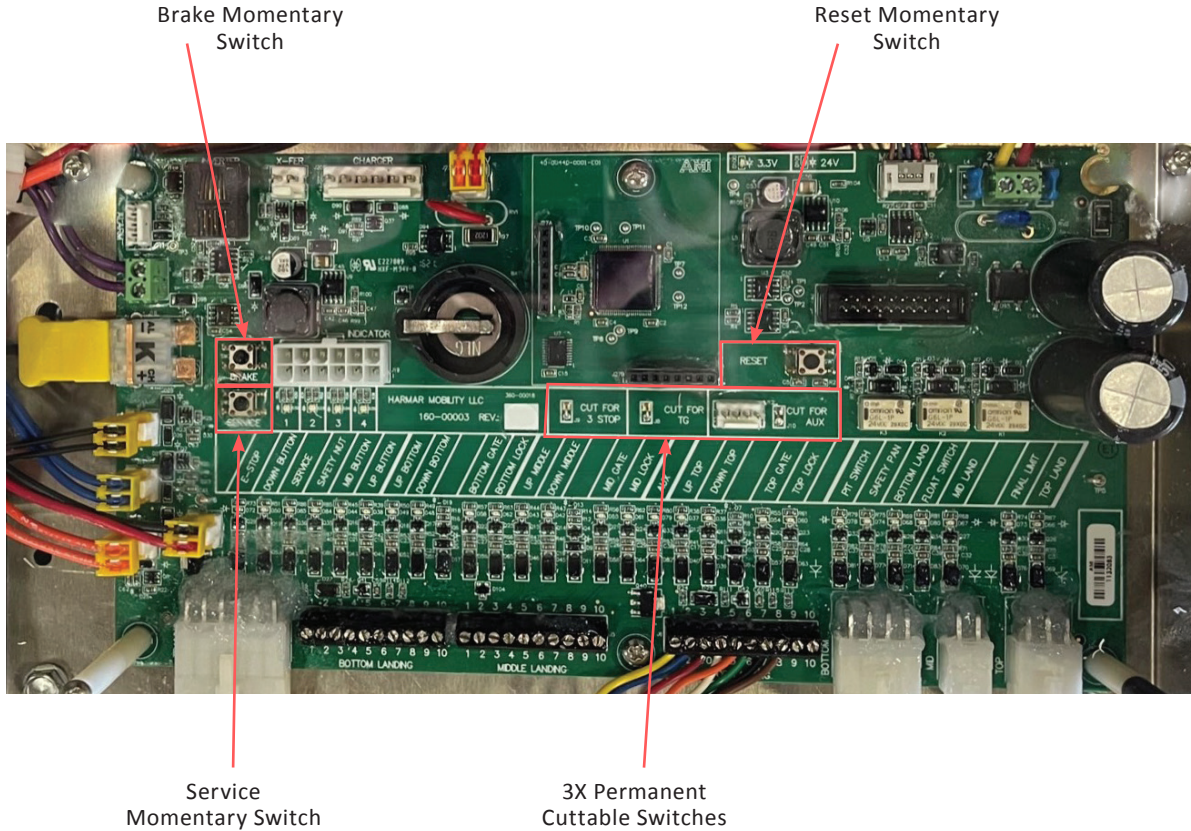

Figure 6-5

### BRAKE MOMENTARY SWITCH

The brake on the back of the gear motor is 24V DC “fail safe,” electromagnetic holding brake. The brake is released when 24V DC is applied. Pressing the BRAKE momentary switch will apply 24V DC and release the brake with an audible “Click.”

This switch can be used to check brake operation and is recommended to be used in the emergency lowering procedure.

### RESET MOMENTARY SWITCH

Pressing the RESET momentary switch will reset the processor and exit “Service Mode” if board were in that mode. “Out of Service Mode” flag is not cleared by pressing the RESET switch.

**WARNING**

Pressing and holding this switch could result in the platform slowly drifting down.

### SERVICE MOMENTARY SWITCH

The SERVICE switch should only be used during installation and for service by authorized technicians.

 **WARNING**

Pressing this switch results in the disabling of safety circuits.

Pressing the SERVICE switch puts the lift into a “Service Mode” which temporarily ignores most safety circuits and major faults allowing the technician to move the platform and troubleshoot issues more easily. All four (4) Indicator LEDs will flash green when the unit is in “Service Mode” and the lift will automatically go back to normal operation after 10-minutes. You can hit the RESET switch to exit “Service Mode” before 10-minutes. All status LEDs on the control board will work normally in “Service Mode.”

Pressing the SERVICE will allow the platform to move if the unit is in “Out of Service Mode”, however the lift will return to “Out of Service Mode” when the “Service Mode” expires.

To reset the “Out of Service Mode” flag and clear memory/errors after required service has completed:

1. Enter “Service Mode” by pressing and releasing the SERVICE switch.
2. Press and hold the SERVICE switch for at least 3 seconds then release.
3. Press and release the RESET switch within 10-minutes.

 **WARNING**

Do not reset the "Out of Service Mode" flag until required service has been performed. Unsafe operation could result.

### PERMANENT CUTTABLE JUMPERS

Three permanent cuttable jumpers are included on the Control Board that allow the software characteristics to change based on configuration. If needed these jumpers are cut in the factory and should never need to change.

#### 3-STOP JUMPER

This jumper is cut in the factory on 3-stop lifts. The control board will ignore any mid landing circuits when this jumper is intact.

#### TG JUMPER (UNUSED)

In the future this jumper will be used on Toe-Guard lifts.

#### AUX JUMPER (UNUSED)

This jumper could be used for future expansion/features.

## **GEARMOTOR**

The VPL uses a 2/3 Hp gearmotor mounted to the top of the tower frame. The brake on the back of the gear motor is a “fail safe,” electromagnetic holding brake. The Motor Gearbox on the front of the motor is a vented 26:1 worm drive gear reduction with synthetic gear and bearing oil.

Motor is designed for a duty cycle of 25% with a maximum continuous operation of 45-minutes. In other words, 45-minutes of continuous operation must be followed by 2-hours and 15-minutes of rest to prevent possible motor damage. Motor temperature is monitored by a thermocouple inside the motor housing. If the motor gets too hot it could restrict travel of platform to DOWN only. If the motor gets so hot that it could cause damage to the motor it will restrict platform movement entirely. Platform movement will be restored after temperatures fall below hot temperature thresholds. See STATUS CODES section for the codes displayed.

# TROUBLESHOOTING

## CONTACTOR TRAY

The Contactor Tray contains other control electronics wired to motor and control tray.  
**See Figure 6-6.**

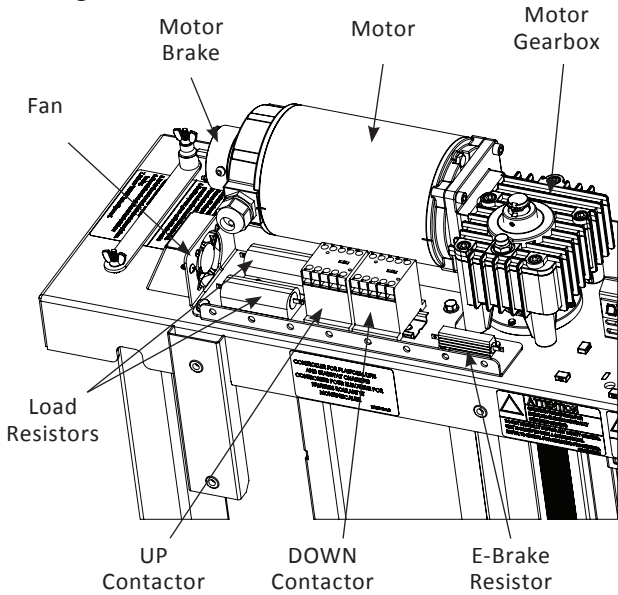

Figure 6-6 (wires not shown)

## UP AND DOWN CONTACTORS

Both contactors have 3-poles with an auxiliary circuit that are switched by 24V AC coils. On top of the contactors is a switch position indicator that can be observed to verify switching is occurring properly. Contactors operate independently and are controlled by the control board.

**⚠ WARNING**

**Do not manually switch the position indicator as all safeties would be bypassed.**

## E-BRAKE RESISTOR

The E-Brake resistor electronically slows the motor quickly via eddy current braking. When both contactors are OFF the resistor essentially shorts the motor leads which resists motor shaft rotation. Braking is proportional to motor speed, so this brake slows the motor very quickly, but does not hold the motor from drifting after it stops. The electromagnetic holding brake on the motor is engaged after the motor comes to a stop. If the platform is taking too long to come to a stop there could be an issue with this resistor or the wiring on it.

## LOAD RESISTORS

The load resistors function is to slow the platforms speed in the DOWN direction. The resistors are in-circuit only when the DOWN contactor is ON and will generate significant heat as they dissipate some of the downward energy. The fan located next to the load resistors is there to cool the resistors.

**⚠ WARNING**

**Load resistors could be very hot. Do not touch.**

## COOLING FAN

The cooling fan is primarily to cool the load resistors, but also cools the top compartment as it pulls air from the tower below. The fan is controlled by a thermostatic switch located on a load resistor. If the fan is not cutting off when the temperature drops there could be an issue with the switch.

## BATTERY BACKUP

If the VPL is equipped with a Battery Backup System, it will be located inside the tower below the top plate. **See Figure 6-7.**

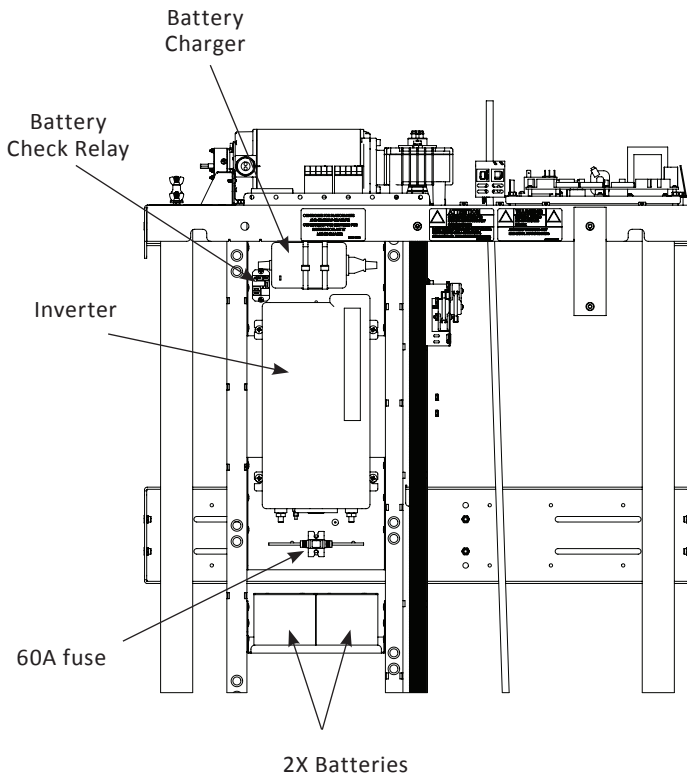

Figure 6-7 (wires not shown)

### **BATTERIES**

Each battery in a VPL is a 12V Sealed Lead Acid battery. VPL400 and VPL600 get two (2) batteries wired in series to provide 24V to the Inverter. VPL800 to VPL1400 get four (4) batteries where two (2) pairs of the batteries are wired in series and the pairs are wired together in parallel to get the 24V to the inverter. Properly maintained batteries are sized to be able to provide user with at least 5 round trips at full load while on battery power. In order to preserve battery life during power outages the lift will shut off the inverter and go into a low power standby mode when the lift is not being used. The unit will automatically "wake up" and check the batteries every 8-hours. Hitting any button or activating a gate will "wake-up" the lift after a 5-second delay.

### **60A FUSE**

Between the positive leads of the batteries and the inverter is an 60A fuse. This fuse protects the batteries and is very unlikely to independently blow unless there is a short during install or service.

### **BATTERY CHARGER**

The battery charger is 24V, 2A with 4-stage charge profiles to maximize battery life. After a power outage it may take 12 to 18-hours to return to a full charge.

### **BATTERY CHECK RELAY**

Since we cannot check battery voltage while the battery is charging, we have a Battery Check Relay that switches between charging and voltage monitoring. The battery voltage is monitored continuously any time while on battery power and checked every 4-hours while on AC power. A failed Battery Check Relay would result in a Very Low Battery warning.

### **INVERTER**

The inverter is 1500W and converts the 24V from the batteries into a 120 Volt modified sine wave to power the lift. The inverter is controlled by the control board via the Inverter Remote Control Cable. There are safeties built into the inverter, however the control board monitors the input and output of the inverter and will go into a fault state to prevent the inverter from tripping. A failed inverter will appear to switch over to battery power but not provide power to drive the motor. The periodic operational checks should include a check of the battery backup system. To do this the breaker must be interrupted at the two (2) pole fused disconnect, the tower junction box or the control tray screw terminal.

# TROUBLESHOOTING

## FLOAT SWITCH

If a float switch is present and the float switch is triggered for more than a minute, you will see a float switch indication (flashing #2 amber).

After 25-trips or 2-weeks in time, the unit will go into "out of service" mode which will not allow it to run (flashing #2 red). This is to protect the safety of the system from being compromised.

Service must be performed in order to restore functionality.

## EMERGENCY EVACUATION PROCEDURE

### CAUTION

Platform lifts should not be used for evacuation during emergencies.

Do not use the lift alone if you are not sure that you can maintain pressure on the control buttons for the duration of travel.

If using the lift alone, and you do not have the optional phone equipped in the cab, it is best practice to have a cell phone with you in case of a malfunction that prevents the platform movement.

If the lift malfunctions while occupied:

- Occupant should follow the directions located next to the platform controls and never try to evacuate the lift on their own.
- Contact dealer and/or 911 (dealers phone number is written on the label next to the cab controls).
- Push in the Red Emergency Stop button on the cab control. If equipped, an alarm will sound.

Once help arrives, they should follow the Emergency Lowering Procedure to evacuate the occupant.

## EMERGENCY LOWERING PROCEDURE

### WARNING

Never exit an elevated platform unless it is fully parked at a landing. Do not attempt to manually lower the device while in the platform.

In the event that the lift becomes disabled with passengers on the platform that is not at a landing, it may be necessary/desirable to manually lower them prior to a technician arriving.

In that case, there is a manual lowering mechanism. A person other than the lift passenger(s) will be required to make their way to the top of the tower to perform this procedure.

### NOTICE

The Highlander II is supplied with manual lowering tools that are located beneath the plastic top cover. Remove these tools and store them in a convenient location. See Figure 6-8.

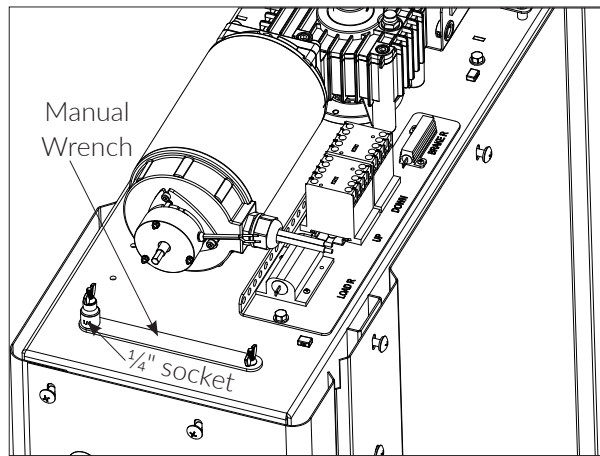

Figure 6-8

4. Use disconnect to remove all power from lift.

5. Remove the plastic cap to access the manual override. *See Figure 6-9.*

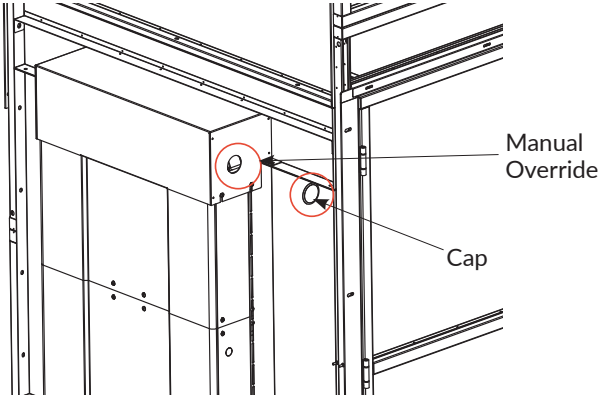

Figure 6-9

6. Use the provided  $\frac{1}{4}$ " socket with a  $\frac{3}{8}$ " ratchet or a cordless drill. Power the drill in the forward direction - rotating clockwise to lower the platform. *See Figure 6-10.*

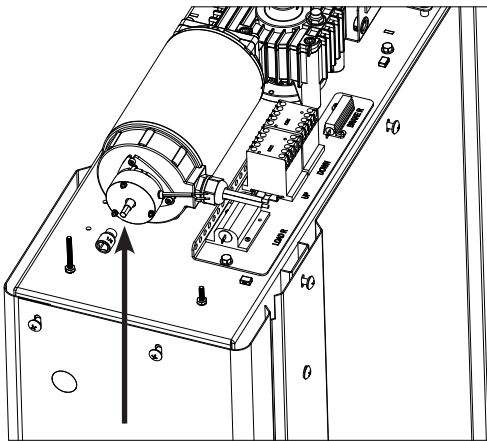

Figure 6-10

*NOTE: The drive motor is equipped with a low holding force brake to prevent the platform from drifting with heavy loads. Lowering the platform with this brake on will require a bit of strength, typically the equivalent of being able to lift 20 lb with one arm.*

*NOTE: Do not attempt to raise the platform. The required torque to do so is substantially higher.*

7. Stop rotation when the platform is level with the lower landing.
8. If the lower door does not open, the crescent key can be used to release it.

**WARNING**

Wait for a Harmar dealer to service and inspect the lift prior to using it again.

# MAINTENANCE

## SECTION 7

# MAINTENANCE & INSPECTION

Annual inspections are highly recommended to help prevent unsafe conditions and operation.

## RESIDENTIAL APPLICATIONS OWNER/MAINTENANCE PERSONAL

### BEFORE USE

Do not use lift until these conditions are rectified.

- Check the dielectric grease on the board and verify all open connections are greased/covered.
- All doors and gates are locked and secure.
- Check for standing water around the unit.
- Make sure the AC connections are in good condition and that there are no cracks or gaps in conduit.
- Make sure there are no obstructions intruding in the path of the lift.
  - People, tree branches, loose items, etc.
- Check that there is no loose hardware or emerging cracks/deformations in the platform and tower. Make sure that there are no unusual noise or vibrations that develop.

### PERIODICALLY

- Check and ensure that the safety pan (if equipped) under the platform moves freely up and down and is not damaged. This is the built-in safety device designed to detect obstructions under the platform and stop platform downward motion. If there is an easy-to-remove obstruction, please remove it. If for any reason the safety pan

does not move as intended, please contact your dealer.

- Check and ensure that all labels are intact and legible. If any safety or warning labels need to be replaced, please contact your dealer.
- Make sure you have a copy of the Owner's Manual. A digital copy of the Owner's Manual is available at [harmar.com](http://harmar.com).
- Check your key locks and emergency stop button for functionality.
- Check for any rust that may be developing. Rust is expected in outdoor applications (especially in coastal areas), but with proactive maintenance or quick repair, this can be minimized. Harmar recommends (weatherizing) the unit to prevent this from occurring.

## COMMERCIAL APPLICATIONS

### END-USER/MAINTENANCE PERSONAL

### IMPORTANT

Understanding State/Local Inspection Requirements and Timing - Always Required.

### BEFORE USE

Do not use lift until these conditions are rectified.

- Check the dielectric grease on the board and verify all open connections are greased/covered.
- All doors and gates are locked and secure.

- Check for standing water around the unit.
- Make sure AC connections are in good condition and that there are no cracks or gaps in conduit.
- Make sure there are no obstructions intruding in the path of the lift.
  - People, tree branches, loose items, etc.
- Check that there is no loose hardware or emerging cracks/deformations in the platform and tower.

**OWNER/OWNER’S AGENT**

- Check and ensure that the safety pan (if equipped) under the platform moves freely up and down and is not damaged. This is the built-in safety device designed to detect obstructions under the platform and stop platform downward motion. If there is an easy-to-remove obstruction, please remove it. If for any reason the safety pan does not move as intended, please contact Harmar Tech services.
- Check and ensure that all labels are intact and legible. If any safety or warning labels need to be replaced, please contact Harmar Tech services.
- Check the pit switch is functioning properly. Trigger the pit switch, exit the elevator shaft and verify that the lift does not run.
- Make sure you have a copy of the Owner’s Manual. A digital copy of the Owner’s Manual is available at harmar.com.
- Check the key locks and emergency stop button for functionality.
- Check for any rust that may be developing. Rust is expected in outdoor applications (especially in coastal areas), but with proactive maintenance or quick repair, this can be minimized.

**MAINTENANCE SCHEDULE  
RECOMMENDED EVERY 6-MONTHS**

**NOTICE**

*We recommend this be performed by a qualified service technician.*

- Check for motor gearbox leaks
- Check wear pads for gaps
- Lubricate ACME screw with Nook PAG-1 ACME Screw Grease
- Check all structural connections/hardware
- Inspect the safety brake
- Check the Battery Backup function (if installed)
- Ensure the Power Cut-Off system works as intended
- Check all interlocks, strikes and obstruction sensors

**RECOMMENDED ANNUALLY**

- Replace batteries (if equipped)

**Enclosure:**

- Screw drive should be inspected annually for grease/ grease adequately if necessary
- Safety switches should be checked for functionality
- Depending on geographical area, unit may need to have additional cosmetic maintenance performed to prevent rusting.
- Waxing may be necessary to insure aesthetics are upheld
- IF equipped with a ventilation system, the batteries should be inspected



1500 Independence Blvd. Suite 220  
Sarasota, FL 34234  
800-833-0478  
[www.harmar.com](http://www.harmar.com)