

5414 Digital Input Module

Installation, Operation and Maintenance
Setup Manual

5/19/2011



The information provided in this documentation contains general descriptions and/or technical characteristics of the performance of the products contained herein. This documentation is not intended as a substitute for and is not to be used for determining suitability or reliability of these products for specific user applications. It is the duty of any such user or integrator to perform the appropriate and complete risk analysis, evaluation and testing of the products with respect to the relevant specific application or use thereof. Neither Schneider Electric nor any of its affiliates or subsidiaries shall be responsible or liable for misuse of the information contained herein. If you have any suggestions for improvements or amendments or have found errors in this publication, please notify us.

No part of this document may be reproduced in any form or by any means, electronic or mechanical, including photocopying, without express written permission of Schneider Electric.

All pertinent state, regional, and local safety regulations must be observed when installing and using this product. For reasons of safety and to help ensure compliance with documented system data, only the manufacturer should perform repairs to components.

When devices are used for applications with technical safety requirements, the relevant instructions must be followed. Failure to use Schneider Electric software or approved software with our hardware products may result in injury, harm, or improper operating results.

Failure to observe this information can result in injury or equipment damage.

© 2010 Schneider Electric. All rights reserved.

Table of Contents

Safety Information	5
About The Book	8
At a Glance	8
Overview.....	9
Installation.....	10
Field Wiring	10
Address Selection	13
Operation and Maintenance.....	15
LED Indicators.....	15
Maintenance.....	15
Troubleshooting	15
Specifications	16
General	16
Power Supply	16
Digital Inputs	16
Approvals and Certifications	18

Index of Figures

Figure 1: AC Input Wiring Example.....	11
Figure 2: DC Input Wiring Example	12
Figure 3: 5414 Digital Input Module Address Switches	14

Safety Information

Read these instructions carefully, and look at the equipment to become familiar with the device before trying to install, operate, or maintain it. The following special messages may appear throughout this documentation or on the equipment to warn of potential hazards or to call attention to information that clarifies or simplifies a procedure.



The addition of this symbol to a Danger or Warning safety label indicates that an electrical hazard exists, which will result in personal injury if the instructions are not followed.



This is the safety alert symbol. It is used to alert you to potential personal injury hazards. Obey all safety messages that follow this symbol to avoid possible injury or death.

DANGER

DANGER indicates an imminently hazardous situation which, if not avoided, **will result in** death or serious injury.

WARNING

WARNING indicates a potentially hazardous situation which, if not avoided, **can result in** death or serious injury.

CAUTION

CAUTION indicates a potentially hazardous situation which, if not avoided, **can result in** minor or moderate.

CAUTION

CAUTION used without the safety alert symbol, indicates a potentially hazardous situation which, if not avoided, **can result in** equipment damage..

PLEASE NOTE

Electrical equipment should be installed, operated, serviced, and maintained only by qualified personnel. No responsibility is assumed by Schneider Electric for any consequences arising out of the use of this material.

A qualified person is one who has skills and knowledge related to the construction and operation of electrical equipment and the installation, and has received safety training to recognize and avoid the hazards involved.

BEFORE YOU BEGIN

Do not use this product on machinery lacking effective point-of-operation guarding. Lack of effective point-of-operation guarding on a machine can result in serious injury to the operator of that machine.

 **CAUTION****EQUIPMENT OPERATION HAZARD**

Verify that all installation and set up procedures have been completed.

Before operational tests are performed, remove all blocks or other temporary holding means used for shipment from all component devices.

Remove tools, meters, and debris from equipment.

Failure to follow these instructions can result in injury or equipment damage.

Follow all start-up tests recommended in the equipment documentation. Store all equipment documentation for future references.

Software testing must be done in both simulated and real environments.

Verify that the completed system is free from all short circuits and grounds, except those grounds installed according to local regulations (according to the National Electrical Code in the U.S.A, for instance). If high-potential voltage testing is necessary, follow recommendations in equipment documentation to prevent accidental equipment damage.

Before energizing equipment:

- Remove tools, meters, and debris from equipment.
- Close the equipment enclosure door.
- Remove ground from incoming power lines.
- Perform all start-up tests recommended by the manufacturer.

OPERATION AND ADJUSTMENTS

The following precautions are from the NEMA Standards Publication ICS 7.1-1995 (English version prevails):

- Regardless of the care exercised in the design and manufacture of equipment or in the selection and ratings of components, there are hazards that can be encountered if such equipment is improperly operated.
- It is sometimes possible to misadjust the equipment and thus produce unsatisfactory or unsafe operation. Always use the manufacturer's instructions as a guide for functional adjustments. Personnel who have access to these adjustments should be familiar with the equipment manufacturer's instructions and the machinery used with the electrical equipment.
- Only those operational adjustments actually required by the operator should be accessible to the operator. Access to other controls should be restricted to prevent unauthorized changes in operating characteristics.

About The Book

At a Glance

Document Scope

This manual describes operation and maintenance of the 5414 Digital Input module.

Validity Notes

This document is valid for all versions of the 5414 Digital Input module.

Product Related Information

 WARNING
UNINTENDED EQUIPMENT OPERATION
The application of this product requires expertise in the design and programming of control systems. Only persons with such expertise should be allowed to program, install, alter and apply this product.
Follow all local and national safety codes and standards.
Failure to follow these instructions can result in death, serious injury or equipment damage.

User Comments

We welcome your comments about this document. You can reach us by e-mail at technicalsupport@controlmicrosystems.com.

Overview

The Model 5414 Digital Input module adds 16 discrete inputs to a 5000 I/O system. Up to 16 Model 5414 modules may be installed on an I/O bus to provide a total of 256 digital inputs.

The digital inputs are optically isolated from the logic power. To simplify field wiring, the inputs are grouped with eight inputs sharing a single common return. These groups of eight inputs are isolated from each other.

The Model 5414 Digital Input module is available in four standard voltage ranges, for both AC and DC applications. A current limiting resistor, on each input, determines the voltage range. Light Emitting Diodes (LEDs) on the digital inputs show the status of each input. The digital input LEDs can be disabled to conserve power.

Installation

The installation of the 5414 module requires mounting the modules on the 7.5mm by 35mm DIN rail and connecting the module to the system I/O Bus. Refer to the **System Configuration Guide** for complete information on system layout, I/O Bus cable routing and module installation.

For ATEX and IECx applications only:

This equipment is to be installed in an enclosure certified for use, providing a degree of protection of IP54 or better. The free internal volume of the enclosure must be dimensioned in order to keep the temperature rating. A T4 rating is acceptable.

Field Wiring

The 5414 module provides 16 digital inputs. The input voltage range is set at the factory. The inputs are grouped with eight inputs sharing a single common return. The groups are isolated from each other.

The 5414 module accommodates AC or DC inputs. Observe signal polarity when using DC inputs. Connect the positive signal to the input. Connect the negative signal to the common return.

Figure 1: AC Input Wiring Example and **Figure 2: DC Input Wiring Example** show typical field wiring.

Controller, modem and I/O modules use screw termination style connectors for termination of field wiring. They accommodate solid or stranded wires from 22 to 12 AWG.

The connectors are removable. This allows module replacement without disturbing the field wiring. Leave enough slack in the wiring for the connector to be removed.

Remove power before servicing unit.

To remove the connector:

- Pull the connector upward from the board. Apply even pressure to both ends of the connector.

To install the connector:

- Line up the pins on the module with the holes in the connector.
- Push the connector onto the pins. Apply even pressure to both ends of the connector.

AC Input Wiring

Figure 1: AC Input Wiring Example shows typical wiring of AC signals to the digital input ports. The Model 5414 is available in different input voltage ranges. Check that the specific range of the input module is not exceeded.

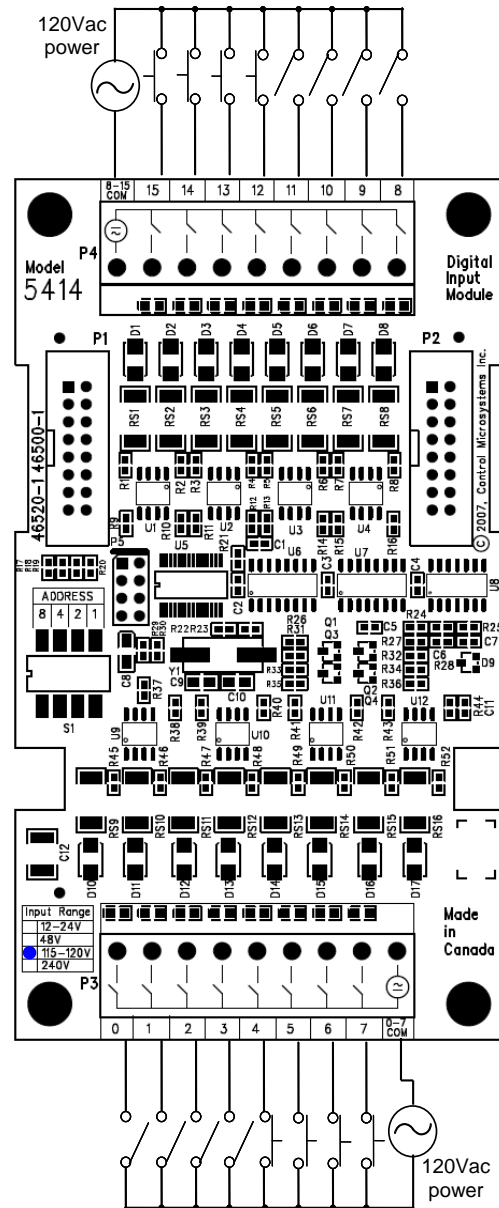

Figure 1: AC Input Wiring Example

DC Input Wiring

Figure 2: DC Input Wiring Example shows typical wiring of DC signals to the digital input ports. Observer signal polarity when using DC input signals. The Model 5414 is available in different input voltage ranges. Check that the signals monitored are in the specified range of the input module.

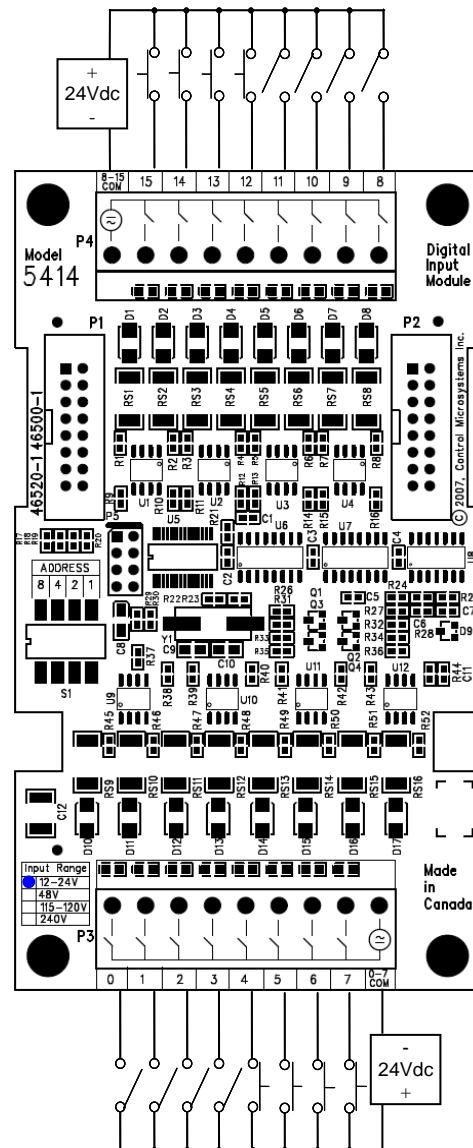

Figure 2: DC Input Wiring Example

Address Selection

The 5000 I/O bus will support a maximum of 20 I/O (input/output) modules. 5000 I/O module types may be combined in any manner to the maximum supported by the controller used. The types of input and output modules available are:

- Digital Input modules
- Digital Output modules
- Analog Input modules
- Analog Output modules
- Counter Input modules

Each type of I/O module connected to the I/O bus, has a unique I/O module address. Different types of I/O modules may have the same module address.

The address range supported by the controller module may restrict the I/O module address range. Refer to the controller manual for the maximum address supported.

The four address switches labeled 8, 4, 2, and 1 set the address. To set the address:

- Open the four switches by sliding the actuators to the “OFF” position.
- Close the switches that total to the desired address by sliding the actuators to “ON”.

Switch settings for each of the 16 module addresses are shown in **Figure 3: 5414 Digital Input Module Address Switches**.

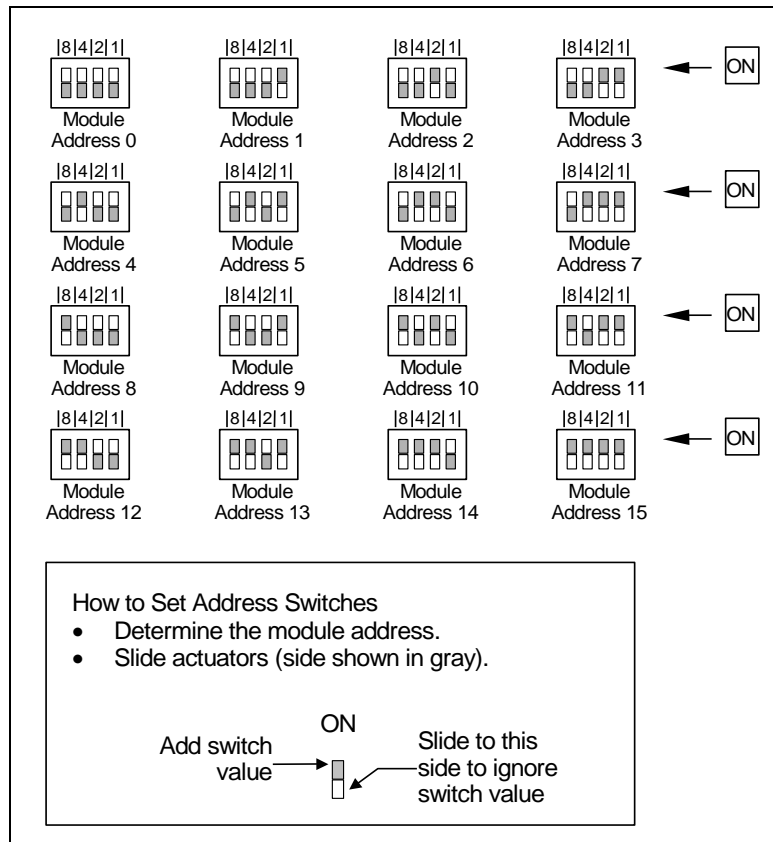

Figure 3: 5414 Digital Input Module Address Switches

Operation and Maintenance

LED Indicators

The Model 5414 Digital Input Module has one red status LED per I/O point. This LED is on when the input is monitoring a voltage greater than the minimum rated input voltage.

The digital input status LED is located between the field wiring terminal connector and the module cover.

The LEDs can be disabled by the controller board to conserve power. Refer to the manual of your controller board for details on disabling the LEDs.

Maintenance

The 5414 module requires no routine maintenance or calibration. If a module is not functioning correctly, contact Control Microsystems Technical Support for more information and instructions on returning the module for repair.

Troubleshooting

Condition	Action
Input LED does not come on when input signal is applied.	Check the input signal at the termination block. It should be at least 50% of the digital input range. If this is a DC input, check the polarity of the signal.
Input is on when no signal is applied. The LED is off.	Check that the digital inputs are not forced on.
Input is off when a signal is applied. The LED is on.	Check that the digital inputs are not forced off.

Specifications

Disclaimer: Control Microsystems reserves the right to change product specifications. For more information visit www.controlmicrosystems.com.

General

I/O Terminations	12 to 22 AWG 15A contacts Screw termination - 6 lb.-in. (0.68 Nm) torque
Dimensions	2.90 inch (74mm) wide 4.90 inch (124mm) high 1.80 inch (45mm) deep
Packaging	corrosion resistant zinc plated steel with black enamel paint
Environment	5% RH to 95% RH, non-condensing -40°C to 70°C (-40°F to 158°F) operation -40°C to 85°C (-40°F to 185°F) storage
Addressing	16 modules. DIP switch selectable.

Power Supply

5V power requirements	6mA with LEDs off 40mA with LEDs on
11-30Vdc power requirements	none

Digital Inputs

Quantity	16
Ranges	Factory configurable 12/24V 48V 115/125V 240V
Over-voltage Tolerance	150% sustained over-voltage without damage
Voltages	Maximum permitted voltage in Canada or North America is 240Vac. Maximum permitted voltage outside of Canada or North America is

	30Vac/42.4Vpk/60Vdc.	
DC Input Current	0.6 – 0.9mA at 24V on the 12/24V range 0.3 – 0.4mA at 48V on the 48V range 0.3 – 0.4mA at 120V on the 115/125V range 0.3 – 0.4mA at 240V on the 240V range	
AC Input Current	0.25 – 0.5mA at 24V on the 12/24V range 0.15 – 0.25mA at 48V on the 48V range 0.15 – 0.25mA at 120V on the 115/125V range 0.15 – 0.25mA at 240V on the 240V range	
Input Logic-HI Level	OFF to ON transition threshold is typically 5.5V on 12/24V range OFF to ON transition threshold is typically 50% of full scale range on other ranges.	
DC Input Voltage	On/Off Threshold	
12V/24V	6 – 7Vdc	
48V	17 – 27Vdc	
115/125V	55 – 75Vdc	
240V	110 – 140Vdc	
AC Input Voltage	Off – To – On	On – To – Off
12V/24V	4.5 – 6.5Vrms	4.0 – 6.0Vrms
48V	16 – 24Vrms	15 – 23Vrms
115/125V	40 – 60Vrms	37 – 57Vrms
240V	80 – 120Vrms	75 – 115Vrms
Connectors	2 removable. 9 positions.	
Isolation	Isolation is in 2 groups of 8. Isolation from logic supply and chassis. 250Vac/1000Vdc.	
Indicators	Logic powered LEDs. Can be disabled to conserve power.	

Approvals and Certifications

Hazardous Locations - North America	<p>Suitable for use in Class I, Division 2, Groups A, B, C and D Hazardous Locations. Temperature Code T4</p> <p>CSA certified to the requirements of:</p> <ul style="list-style-type: none"> • CSA Std. C22.2 No. 213-M1987 - Hazardous Locations. • UL Std. No. 1604 - Hazardous (Classified) Locations.
Hazardous Locations - Europe	<p>5414-24 (24V DI version) only</p> <p>ATEX II 3G, Ex nA IIC T4</p> <p>per EN 60079-15, protection type n (Zone 2)</p>
Hazardous Locations	<p>IECEX, Ex nA IIC T4</p> <p>per IEC 60079-15, protection type n (Zone 2)</p>
ATEX and IECEX Applications only	<p>This equipment is to be installed in an enclosure certified for use, providing a degree of protection of IP54 or better. The free internal volume of the enclosure must be dimensioned in order to keep the temperature rating. A T4 rating is acceptable.</p> <p>For products using Solid State Relays (5415, 5606 and 5607 modules and SCADAPack using 5606 and 5607 modules) A T4 rating is acceptable for maximum loads of 2A. When 3A loads are connected to the Solid State Relays, the maximum ambient rating is lowered to 50°C in order to maintain the T4 rating.</p>
Safety	<p>CSA (cCSAus) certified to the requirements of: CSA C22.2 No. 142-M1987 and UL916. (Process Control Equipment, Industrial Control Equipment) in Canada and USA.</p> <p>UL (cULus) listed: UL508 (Industrial Control Equipment)</p>
Digital Emissions	<p>FCC 47 Part 15, Subpart B, Class A Verification</p> <p>EN61000-6-4: 2007 Electromagnetic Compatibility Generic Emission Standard Part2: Industrial Environment C-Tick compliance. Registration number N15744.</p>
Immunity	<p>EN61000-6-2: 2005 Electromagnetic Compatibility Generic Standards Immunity for Industrial Environments</p>
Declaration	<p>This product conforms to the above Emissions and Immunity Standards and therefore conforms with the requirements of Council Directive 2004/108/EEC (as amended) relating to electromagnetic compatibility and is eligible to bear the CE mark.</p>

The Low Voltage Directive 2006/95/EC applies to devices operating within 75 to 1500 VDC and/or 50 to 1000 VAC. This Directive is not applicable to this product when installed according to our specifications.