

5103 Power Supply

Installation, Operation and Maintenance Setup Manual

5/19/2011



The information provided in this documentation contains general descriptions and/or technical characteristics of the performance of the products contained herein. This documentation is not intended as a substitute for and is not to be used for determining suitability or reliability of these products for specific user applications. It is the duty of any such user or integrator to perform the appropriate and complete risk analysis, evaluation and testing of the products with respect to the relevant specific application or use thereof. Neither Schneider Electric nor any of its affiliates or subsidiaries shall be responsible or liable for misuse of the information contained herein. If you have any suggestions for improvements or amendments or have found errors in this publication, please notify us.

No part of this document may be reproduced in any form or by any means, electronic or mechanical, including photocopying, without express written permission of Schneider Electric.

All pertinent state, regional, and local safety regulations must be observed when installing and using this product. For reasons of safety and to help ensure compliance with documented system data, only the manufacturer should perform repairs to components.

When devices are used for applications with technical safety requirements, the relevant instructions must be followed. Failure to use Schneider Electric software or approved software with our hardware products may result in injury, harm, or improper operating results.

Failure to observe this information can result in injury or equipment damage.

© 2010 Schneider Electric. All rights reserved.

Table of Contents

Safety Information	5
About The Book	8
At a Glance	8
Overview.....	9
Installation.....	10
Field Wiring	10
Operation and Maintenance.....	13
LED Indicators.....	13
Fuses	13
Output Capability.....	13
Troubleshooting	14
Calibration	14
Specifications	15
Approvals and Certifications	16

Index of Figures

Figure 1: 5103 Typical Field Wiring Connections.....	11
--	----

Safety Information

Read these instructions carefully, and look at the equipment to become familiar with the device before trying to install, operate, or maintain it. The following special messages may appear throughout this documentation or on the equipment to warn of potential hazards or to call attention to information that clarifies or simplifies a procedure.



The addition of this symbol to a Danger or Warning safety label indicates that an electrical hazard exists, which will result in personal injury if the instructions are not followed.



This is the safety alert symbol. It is used to alert you to potential personal injury hazards. Obey all safety messages that follow this symbol to avoid possible injury or death.

DANGER

DANGER indicates an imminently hazardous situation which, if not avoided, **will result in** death or serious injury.

WARNING

WARNING indicates a potentially hazardous situation which, if not avoided, **can result** in death or serious injury.

CAUTION

CAUTION indicates a potentially hazardous situation which, if not avoided, **can result** in minor or moderate.

CAUTION

CAUTION used without the safety alert symbol, indicates a potentially



hazardous situation which, if not avoided, **can result** in equipment damage..

PLEASE NOTE

Electrical equipment should be installed, operated, serviced, and maintained only by qualified personnel. No responsibility is assumed by Schneider Electric for any consequences arising out of the use of this material.

A qualified person is one who has skills and knowledge related to the construction and operation of electrical equipment and the installation, and has received safety training to recognize and avoid the hazards involved.

BEFORE YOU BEGIN

Do not use this product on machinery lacking effective point-of-operation guarding. Lack of effective point-of-operation guarding on a machine can result in serious injury to the operator of that machine.

CAUTION

UNINTENDED EQUIPMENT OPERATION

- Verify that all installation and set up procedures have been completed.
- Before operational tests are performed, remove all blocks or other temporary holding means used for shipment from all component devices.
- Remove tools, meters, and debris from equipment

Failure to follow these instructions can result in death, serious injury or equipment damage.

Follow all start-up tests recommended in the equipment documentation. Store all equipment documentation for future references.

Software testing must be done in both simulated and real environments.

Verify that the completed system is free from all short circuits and grounds, except those grounds installed according to local regulations (according to the National Electrical Code in the U.S.A, for instance). If high-potential voltage testing is necessary, follow recommendations in equipment documentation to prevent accidental equipment damage.

Before energizing equipment:

- Remove tools, meters, and debris from equipment.
- Close the equipment enclosure door.
- Remove ground from incoming power lines.
- Perform all start-up tests recommended by the manufacturer.

OPERATION AND ADJUSTMENTS

The following precautions are from the NEMA Standards Publication ICS 7.1-1995 (English version prevails):

- Regardless of the care exercised in the design and manufacture of equipment or in the selection and ratings of components, there are hazards that can be encountered if such equipment is improperly operated.
- It is sometimes possible to misadjust the equipment and thus produce unsatisfactory or unsafe operation. Always use the manufacturer's instructions as a guide for functional adjustments. Personnel who have access to these adjustments should be familiar with the equipment manufacturer's instructions and the machinery used with the electrical equipment.
- Only those operational adjustments actually required by the operator should be accessible to the operator. Access to other controls should be restricted to prevent unauthorized changes in operating characteristics.

About The Book

At a Glance

Document Scope

This manual describes the 5103 Power Supply.

Validity Notes

This document is valid for all versions of the 5102 Power Supply.

Product Related Information



UNINTENDED EQUIPMENT OPERATION

The application of this product requires expertise in the design and programming of control systems. Only persons with such expertise should be allowed to program, install, alter and apply this product.

Follow all local and national safety codes and standards.

Failure to follow these instructions can result in death, serious injury or equipment damage.

User Comments

We welcome your comments about this document. You can reach us by e-mail at technicalsupport@controlmicrosystems.com.

Overview

The Model 5103 power supply provides operating power for SCADAPack controllers and 5000 I/O and modem modules. The 5V output powers the modules. The 24V output powers analog current loops.

The Model 5103 power supply provides a battery charger. The battery charger operates when a suitable voltage is applied to the main power. The charger output trickle charges a 12V gelled electrolyte battery. If the main power is unavailable the power supply operates from the battery. This feature keeps your system up and running during power outages including loop powered instrumentation such as pressure and level transmitters.

The Model 5103 power supply uses cool running, transformer isolated, switch-mode technology for high efficiency and reliability. The 5V and 24V outputs are isolated from the input and from each other. Isolation of the two outputs ensures that the SCADAPack controller module and I/O module logic are not affected by analog current loop electrical noise, static discharge or grounding.

Model 5103 power supplies can be cascaded to provide the necessary power capacity for any size of system.

Installation

The installation of the 5103 power supply module requires mounting the power supply on the 7.5mm by 35mm DIN rail and connecting the power supply to the system I/O Bus. Refer to the **System Configuration Guide**, at the beginning of this manual, for complete information on system layout, I/O Bus cable routing and module installation.

Field Wiring

Field wiring for the model 5103 power supply terminates on an 10 pole connector. The table below describes the termination connector.

Terminal	Function
1	Chassis ground
2 and 3	Input power (see section 0-Input Power)
4 and 5	Battery charger (see section 0-Battery Charger Operation)
6	No connection
7 and 8	5V output (see section 0-Outputs)
9 and 10	24V output (see section 0-Outputs)

Voltage referred to as V_{rms} (or VAC on some products) indicates AC power. Voltage referred to as V indicates DC power.

Controller, modem and I/O modules use screw termination style connectors for termination of field wiring. They accommodate solid or stranded wires from 22 to 12 AWG.

The connectors are removable. This allows module replacement without disturbing the field wiring. Leave enough slack in the wiring for the connector to be removed.

Remove power before servicing unit.

To remove the connector:

- Pull the connector upward from the board. Apply even pressure to both ends of the connector.

To install the connector:

- Line up the pins on the module with the holes in the connector aligning the pins properly.

- Push the connector onto the pins. Apply even pressure to both ends on the connector.

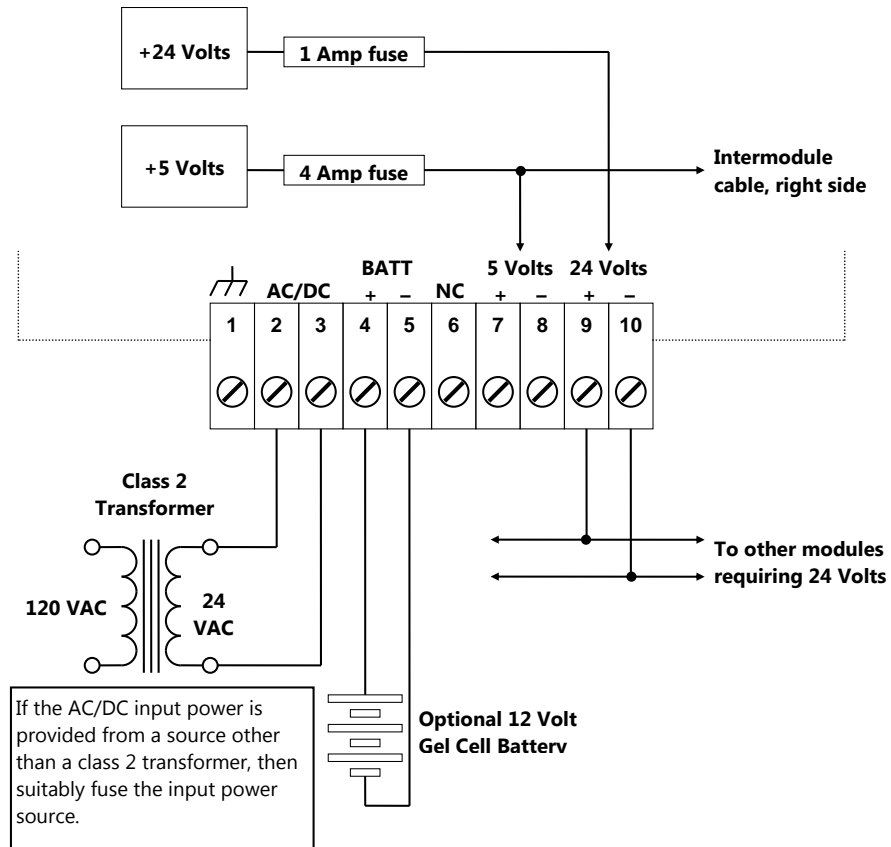

Figure 1: 5103 Typical Field Wiring Connections

Input Power

The model 5103 power supply accepts AC or DC input power. Connect a power source to the input power in any of the following ways.

- 16-24 VAC source connected to the AC/DC input. See section **Specifications** for additional limits.
- 14-36 VDC source connected to the AC/DC input. The polarity of the source does not matter. See section **Specifications** for additional limits.
- 12-36 VDC source connected to the BATT input. Observe polarity on the BATT input. See section **Specifications** for additional limits.

Remove power before servicing unit.

The BATT input has a lower input voltage requirement than the AC/DC input. It is recommended when the input is marginal, as is the case with battery operation. It is also recommended for solar powered applications.

Figure 1: 5103 Typical Field Wiring Connections shows typical input power wiring. The AC transformer is a class 2 (current limiting) device. It does not require a fuse. If the input source is not class 2, then a suitable fuse is required.

Control Microsystems can provide a class 2 transformer suitable for powering the 5103 from 115 VAC and 220 VAC sources.

Battery Charger Operation

The battery charger circuit provides a constant voltage, current limited power source at the BATT input power terminals. The charger operates when an AC or DC voltage is applied to the AC/DC terminals. See section **Specifications** for limits on this voltage. A voltage suitable for charging a 12V Gel-Cell battery is present at the BATT terminals. When power is removed from the AC/DC terminals, the 5103 will start operating from the voltage present at the BATT input. **Figure 1: 5103 Typical Field Wiring Connections** shows a typical battery connection.

Outputs

The model 5103 power supply has two outputs:

- 5 volts at 2 Amp
- 24 volts at 0.5 Amp

The outputs are isolated from the input power and from each other. Each output is fused (see section **Fuses**). LEDs indicate the status of the output power (see section **LED Indicators**).

The 5V output is available on both the terminal block and the right-hand side I/O bus connector. The I/O bus connector distributes the 5V output to other modules. The 5V output on the terminal block is available to power devices that require 5V.

Exercise care when using the 5V output with an external device. The controller and I/O modules use this supply. Keep the supply free of noise.

The 24V output is available on the terminal block. Some I/O modules require a 24V supply from this output. It is also available to power devices that require a 24V supply, such as 20mA loop powered transmitters.

Operation and Maintenance

This module requires no routine maintenance. If the module is not functioning correctly, contact Control Microsystems Technical Support for more information and instructions for returning the module for repair.

LED Indicators

There are two green LEDs on the top of the module. They indicate the state of the 5V and 24V power supplies. The LEDs are off when the fuse is blown and when the power supply is not working.

The power supplies LEDs are powered directly by the supply. They are not affected by the LED power signal on the I/O bus.

Fuses

Picofuse type fuses protect the 5V and 24V power supplies. The fuses are mounted on the circuit board under the cover. An ohmmeter is required to determine if picofuses are blown.

Remove power before servicing unit.

Replace a blown fuse with a fuse of the same rating. Under no circumstances should a fuse be bypassed or replaced with a fuse of a higher rating.

- In all cases investigate the cause of the blown fuse before replacement. Common causes of blown fuse are wiring and excessive input voltages.
- A 4A picofuse (F1) is used to fuse the 5V power supply. Replace this fuse only with Littelfuse part LF251004. Replacement fuses are available from Control Microsystems. Order part TBUM297260.
- A 1A picofuse (F2) is used to fuse the 24V power supply. Replace this fuse only with Littelfuse part LF251001. Replacement fuses are available from Control Microsystems. Order part TBUM297256.
- Picofuses are formed and trimmed to size before they are installed. Form the fuse leads on 0.5 inch (12.5mm) centers. Trim the leads 0.25 inches (6mm) from the bend.

Output Capability

The 5103 power supply has two outputs capable of delivering 17W in total. The maximum outputs of 5V at 2A and 24V at 0.5A are used when calculating the power output. The following examples show how this output power can be distributed between the 5V and 24V outputs.

- If an application requires 0.5A from the 24V supply then 12W (24V X 0.5A) is subtracted from 17W leaving 5W available on the 5V output. The maximum current available from the 5V output is 1A (5W/5V).
- If an application requires 2A from the 5V supply then 10W (5V X 2A) is subtracted from 17W leaving 7W available on the 24V output. The maximum current available from the 24V output is 0.29A (7W/24V).

Troubleshooting

Condition	Action
Both the 5V and 24V LEDs are off.	check the input power and input power wiring check the 5V fuse check the 24V fuse if operating from the BATT input, check that the input voltage exceeds the turn on voltage
The 5V LED only is off.	check the 5V fuse check inter-module cables connecting the power supply with other modules check devices powered from the 5V output
The 24V LED only is off.	check the 24V fuse check devices powered from the 24V output

Calibration

The 5103 module is calibrated and burned in at the factory. It does not require periodic calibration. Calibration may be necessary if the module has been repaired as the result of damage.

Two outputs require calibration; the 5V output and the battery charger output. To calibrate the 5V output:

- Locate the 5V ADJ. potentiometer (R19).
- Adjust the output to 5.15 volts.
- To calibrate the battery charger:
- Locate the CHARGER potentiometer (R24).
- Place a 10 K Ω load on the battery charger output.
- Adjust the output to 13.5 volts.

Specifications

Disclaimer: Control Microsystems reserves the right to change product specifications. For more information visit www.controlmicrosystems.com.

AC/DC Input	16 to 24VAC for 5/24V outputs operational 24VAC required for battery charging 14.5+/-0.5V for 5/24V outputs operational 20VDC required for battery charging
DC/Battery Input	Turn on at 11.5 +/- 0.3VDC Turn off at 10.5 +/- 0.5VDC Maximum input is 36VDC
Input Power	35VA maximum at 24VAC 1.9A at 13.5VDC
Outputs	5VDC at 2.0 ampere. 24VDC at 0.5 ampere 17W total available from the two outputs 11 to 14VDC battery charger at 200mA (factory adjusted to 13.5V for gelled electrolyte lead/acid battery)
Mode	Isolated switch-mode, 30 kHz switch frequency
Line regulation	< 1% over operating range
Load Regulation	5V output: 5.15V +/- 1% over operating range 24V output: +/- 17%
Output Ripple	5V output: < 10mV at 20 °C 24V output: < 50mV at 20 °C
Visual Indicators	5V and 24V green LEDs show power status
Terminations	10 pole, removable terminal block 12 to 22 AWG 15 amp contacts
Dimensions	4.25 inch (108mm) wide 4.625 inch (118mm) high 1.75 inch (44mm) deep
Mounting	7.5 x 35 DIN rail
Packaging	corrosion resistant zinc plated steel with black enamel paint
Environment	5% RH to 95% RH, non-condensing -40°C to 60°C -40°F to 140°F

Approvals and Certifications

Safety	<p>Non-Incendive Electrical Equipment for Use in Class I, Division 2 Groups A, B, C and D Hazardous Locations. Temperature Code T4 at 60°C ambient.</p> <p>UL Listed to the following standards:</p> <ul style="list-style-type: none"> • CSA Std. C22.2 No. 213-M1987 - Hazardous Locations. • CSA Std. C22.2 No. 142-M1987 - Process Control Equipment. • UL Std. No. 1604 - Hazardous (Classified) Locations. • UL Std. No. 508 - Industrial Control Equipment.
Digital Emissions	<p>FCC Part 15, Subpart B, Class A Verification</p> <p>EN61000-6-4: Electromagnetic Compatibility Generic Emission Standard Part2: Industrial Environment</p> <p>C-Tick compliance. Registration number N15744.</p>
Immunity	<p>EN61000-6-2: Electromagnetic Compatibility Generic Standards Immunity for Industrial Environments</p>
Declaration	<p>This product conforms to the above Emissions and Immunity Standards and therefore conforms with the requirements of Council Directive 2004/108/EEC (as amended) relating to electromagnetic compatibility and is eligible to bear the CE mark.</p> <p>The Low Voltage Directive is not applicable to this product.</p>