

SCADAPack Controller

Installation, Operation and Maintenance Manual

5/19/2011



The information provided in this documentation contains general descriptions and/or technical characteristics of the performance of the products contained herein. This documentation is not intended as a substitute for and is not to be used for determining suitability or reliability of these products for specific user applications. It is the duty of any such user or integrator to perform the appropriate and complete risk analysis, evaluation and testing of the products with respect to the relevant specific application or use thereof. Neither Schneider Electric nor any of its affiliates or subsidiaries shall be responsible or liable for misuse of the information contained herein. If you have any suggestions for improvements or amendments or have found errors in this publication, please notify us.

No part of this document may be reproduced in any form or by any means, electronic or mechanical, including photocopying, without express written permission of Schneider Electric.

All pertinent state, regional, and local safety regulations must be observed when installing and using this product. For reasons of safety and to help ensure compliance with documented system data, only the manufacturer should perform repairs to components.

When devices are used for applications with technical safety requirements, the relevant instructions must be followed. Failure to use Schneider Electric software or approved software with our hardware products may result in injury, harm, or improper operating results.

Failure to observe this information can result in injury or equipment damage.

© 2010 Schneider Electric. All rights reserved.

Table of Contents

Safety Information	5
About The Book	8
At a Glance	8
Overview.....	9
Installation.....	11
Integrated SCADAPack	11
Field Wiring	12
Power Supply	14
Overview and Requirements.....	14
Power Supply Input Connections	14
Sample Power Supply Calculations	17
System Grounding	22
Analog Inputs	23
Analog Outputs	24
Digital Inputs	25
Digital/Counter Inputs.....	25
Interrupt Input.....	27
Digital Outputs	29
Wiring Example	29
Serial Communication	31
RS-232 Serial Communication Ports	31
DE-9P Connector for RS-232	33
RS-232 Wiring Examples.....	34
RS-485 Serial Communication Port	36
RS-485 Wiring Examples.....	38
Operation.....	41

Operating Modes.....	41
LED Indicators.....	43
Led Power Control	44
Jumpers	44
Status LED and Output	45
Configuration DIP Switches	46
5000 Analog Input Module Compatibility	49
Firmware Loading	50
Maintenance	51
Fuse	51
Lithium Battery	52
Battery Replacement Procedure	52
Specifications	53
General	53
Communications	53
Visual Indicators.....	54
Power Supply	55
I/O Expansion Capacity	55
Digital Inputs	55
Digital Outputs.....	56
Approvals and Certifications	57

Index of Figures

Figure 1: 5203 Controller Board Layout	13
Figure 2: 5204 Controller Board Layout	13
Figure 3: Recommended AC Power Supply Configuration.....	15
Figure 4: Recommended DC Power Supply Configuration	16
Figure 5: Recommended 5103 Power Supply Configuration.....	17
Figure 6: Grounding Configuration.....	22
Figure 7: Digital/Counter (DIN/COUNTERS) Input Wiring.....	26
Figure 8: Interrupt Input (INT) Wiring	28
Figure 9: STATUS Output Wiring.....	30
Figure 10: RS-232 Port Connector	33
Figure 11: RS-232 DTE to RS-232 DTE without Handshaking	34
Figure 12: RS-232 DTE to RS-232 DTE with Handshaking	35
Figure 13: RS-232 DTE to RS-232 DCE.....	35
Figure 14: Four Mode Wiring to a RS-485 Port.....	37
Figure 15: Two Mode Wiring to a RS-485 Port	37
Figure 16: RS 485 Field Wiring – Four Wire Mode.....	39
Figure 17: RS 485 Field Wiring – Two Wire Mode	40
Figure 18: Low Pass Filter DIP Switches.....	47
Figure 19: Hardware Reset DIP Switch	47
Figure 20: AIN Range DIP Switch.....	48
Figure 21: AO Range DIP Switch	49
Figure 22: Input Frequency Processing DIP Switch.....	49

Safety Information

Read these instructions carefully, and look at the equipment to become familiar with the device before trying to install, operate, or maintain it. The following special messages may appear throughout this documentation or on the equipment to warn of potential hazards or to call attention to information that clarifies or simplifies a procedure.



The addition of this symbol to a Danger or Warning safety label indicates that an electrical hazard exists, which will result in personal injury if the instructions are not followed.



This is the safety alert symbol. It is used to alert you to potential personal injury hazards. Obey all safety messages that follow this symbol to avoid possible injury or death.

DANGER

DANGER indicates an imminently hazardous situation which, if not avoided, **will result in** death or serious injury.

WARNING

WARNING indicates a potentially hazardous situation which, if not avoided, **can result** in death or serious injury.

CAUTION

CAUTION indicates a potentially hazardous situation which, if not avoided, **can result** in minor or moderate.

CAUTION

CAUTION used without the safety alert symbol, indicates a potentially



hazardous situation which, if not avoided, **can result** in equipment damage..

PLEASE NOTE

Electrical equipment should be installed, operated, serviced, and maintained only by qualified personnel. No responsibility is assumed by Schneider Electric for any consequences arising out of the use of this material.

A qualified person is one who has skills and knowledge related to the construction and operation of electrical equipment and the installation, and has received safety training to recognize and avoid the hazards involved.

BEFORE YOU BEGIN

Do not use this product on machinery lacking effective point-of-operation guarding. Lack of effective point-of-operation guarding on a machine can result in serious injury to the operator of that machine.

CAUTION

UNINTENDED EQUIPMENT OPERATION

- Verify that all installation and set up procedures have been completed.
- Before operational tests are performed, remove all blocks or other temporary holding means used for shipment from all component devices.
- Remove tools, meters, and debris from equipment

Failure to follow these instructions can result in death, serious injury or equipment damage.

Follow all start-up tests recommended in the equipment documentation. Store all equipment documentation for future references.

Software testing must be done in both simulated and real environments.

Verify that the completed system is free from all short circuits and grounds, except those grounds installed according to local regulations (according to the National Electrical Code in the U.S.A, for instance). If high-potential voltage testing is necessary, follow recommendations in equipment documentation to prevent accidental equipment damage.

Before energizing equipment:

- Remove tools, meters, and debris from equipment.
- Close the equipment enclosure door.
- Remove ground from incoming power lines.
- Perform all start-up tests recommended by the manufacturer.

OPERATION AND ADJUSTMENTS

The following precautions are from the NEMA Standards Publication ICS 7.1-1995 (English version prevails):

- Regardless of the care exercised in the design and manufacture of equipment or in the selection and ratings of components, there are hazards that can be encountered if such equipment is improperly operated.
- It is sometimes possible to misadjust the equipment and thus produce unsatisfactory or unsafe operation. Always use the manufacturer's instructions as a guide for functional adjustments. Personnel who have access to these adjustments should be familiar with the equipment manufacturer's instructions and the machinery used with the electrical equipment.
- Only those operational adjustments actually required by the operator should be accessible to the operator. Access to other controls should be restricted to prevent unauthorized changes in operating characteristics.

About The Book

At a Glance

Document Scope

This manual describes the operation and maintenance of the SCADAPack controller.

Validity Notes

This document is valid for all versions of the SCADAPack controller.

Product Related Information

 WARNING
UNINTENDED EQUIPMENT OPERATION The application of this product requires expertise in the design and programming of control systems. Only persons with such expertise should be allowed to program, install, alter and apply this product. Follow all local and national safety codes and standards. Failure to follow these instructions can result in death, serious injury or equipment damage.

User Comments

We welcome your comments about this document. You can reach us by e-mail at technicalsupport@controlmicrosystems.com.

Overview

The SCADAPack controllers comprise of a 5203 or 5204 controller board with an integrated I/O module. Collectively, the 5203 and 5204 controller boards are referred to as the 520x controller board in this manual. These controller boards are identical in every respect with the following exception:

- The 5203 controller board has two RS-232 serial communication ports wired to a DE-9P connector.
- The 5204 controller board has one RS-232 serial communication port wired to a DE-9P connector and an RS-485 port wired to a six-pole termination block.

The RS-232 serial ports support RTS/CTS hardware handshaking for connection to phone or radio modems and half or full-duplex communication. Serial ports operate at speeds from 300 to 38400 baud. The RS-485 port can be multi-dropped with a maximum of 32 devices in a 2-wire or 4-wire configuration.

In addition to the I/O capacity and (optional) serial communication channel provided by the lower integrated I/O module, both controller boards provide three digital/counter inputs, interrupt input/counter and a digital status output.

The 520x controller board can be found in either of the following SCADAPack controller configurations:

- **SCADAPack P1:** 520x controller board with an integrated 5601/A I/O Module. Refer to the 5601 I/O module user manual for additional information.
- **SCADAPack P1A:** 520x controller board with an integrated 5604 I/O module. Refer to the 5604 I/O module user manual for additional information.
- **SCADAPack P1B:** 520x Controller board with an integrated 5606 I/O module. Refer to the 5606 I/O module user manual for additional information.
- **SCADAPack Plus:** 520x Controller board with an integrated 5601 and 5602 I/O module. Refer to the 5601 or 5602 I/O module user manual for additional information.
- **SCADAPack Light:** 520x Controller board with an integrated 5602 I/O module. Refer to the 5602 I/O module user manual for additional information.

- **Micro 16** comprises of the 520x controller board only.

The onboard memory for the 520x board is 512kBytes flash ROM, and 1MBytes RAM. The CMOS RAM is non-volatile (battery backed). An EEPROM (1kBytes) stores configuration parameters.

Low power applications can benefit from the SCADAPack sleep mode feature during which other services besides the counter inputs, interrupt input and real time clock wake methods are shut down. On the SCADAPack P1A controller, additional power savings is attainable by using the power management features built into a 12V to 24V boost converter.

This manual covers wiring, configuration and operation of the 520x controller board only. It meant to be used in conjunction with the hardware manual of the respective I/O module that comes with your controller.

Installation

The installation of SCADAPack controllers requires mounting on a 7.5mm by 35mm DIN rail and connecting the controller to the system I/O Bus. At the bottom of each controller is a mounting panel that is adjustable via slots on either side of the controller board. These slots are accessible only with the top cover off.

Refer to the **System Configuration Guide** for complete information on system layout, I/O Bus cable routing and SCADAPack controller installation.

This manual covers wiring, configuration and operation of the 520x controller board only. It meant to be used in conjunction with the hardware manual of the respective I/O module that comes with your controller.

Integrated SCADAPack

An integrated SCADAPack controller comprises of a 520x controller and a lower integrated I/O module. Communication between the controller board and the I/O module occurs via an Inter Module Cable (IMC). The IMC cable also provides 5V from the controller board power supply to the integrated I/O module and expansion 5000 modules. An Integrated SCADAPack could be:

- SCADAPack: 520x controller board with 5601, 5604 or 5606 I/O module.
- SCADAPack Light: 520x controller board with 5602 I/O module.
- SCADAPack Plus: 520x controller board with 5601, 5604 or 5606 and 5602 I/O module

The I/O module is configured using jumper links on the controller or I/O module circuit board. Data from the I/O module is made available to a user program using one of the following methods:

- For Telepace applications use the **Register Assignment** to configure the I/O module you are using.
- For IEC-61131-1 applications use the Complex Equipment I/O connection to configure the I/O module you are using.

This manual covers wiring, configuration and operation of the 520x controller board only. It meant to be used in conjunction with the hardware manual of the respective I/O module that comes with your controller.

Field Wiring

SCADAPack controllers use screw termination style connectors for termination of field wiring. These connectors accommodate solid or stranded wires from 12 to 22 AWG.

The connectors fit over pins on the controller board and the I/O modules. The connectors are removable allowing replacement of the SCADAPack Controller without disturbing the field wiring. Leave enough slack in the field wiring for the connector to be removed.

CAUTION

Remove power before servicing unit.

To remove the termination connector:

- Pull the connector upward from the board. Apply even pressure to both ends of the connector.

Termination Connector Installation

To install the termination connector:

- Line up the pins on the module with the holes in the connector aligning the pins properly.
- Push the connector onto the pins. Apply even pressure to both ends of the connector.

Field Wiring Connectors

The controller board has four termination connectors for field wiring. Refer to **Figure 1: 5203 Controller Board Layout** or **Figure 2: 5204 Controller Board Layout** for connector locations.

Primary power input connections; output power connection and ground connections are wired to a six-pole connector labeled P3. Refer to Section **0-Power Supply** for instructions on how to wire the controller board to a power supply.

The three digital/counter inputs (DIN/Counters), interrupt input/counter (INT/Cntr) and status output (STATUS) are wired to an eight-pole connector labeled P6. Refer to Section **Digital/Counter Inputs** and **Digital Outputs** for more information.

The 5203 controller board has two RS-232 serial communication ports that are wired to DE-9P plug connectors. COM 1 connector is labeled P3 and COM 2 connector is labeled P4. Refer to Section **RS-232 Serial Communication Ports** for more information.

The 5204 version of the controller board has one RS-232 serial communication port, COM 2, which is wired to a DE-9P plug connector and one RS-485 serial communication port, COM 1, which is wired to a six-pole connector. COM 1 connector is labeled P3 and COM 2 connector is labeled P4. Refer to Section **RS-232 Serial Communication Ports** for more information

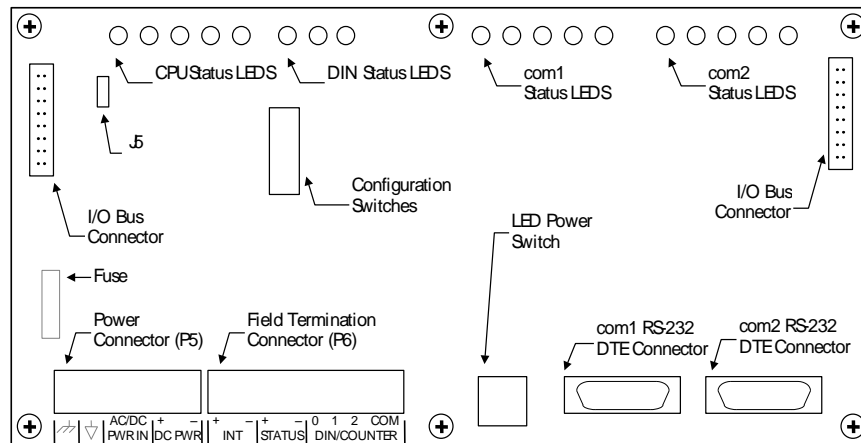

Figure 1: 5203 Controller Board Layout

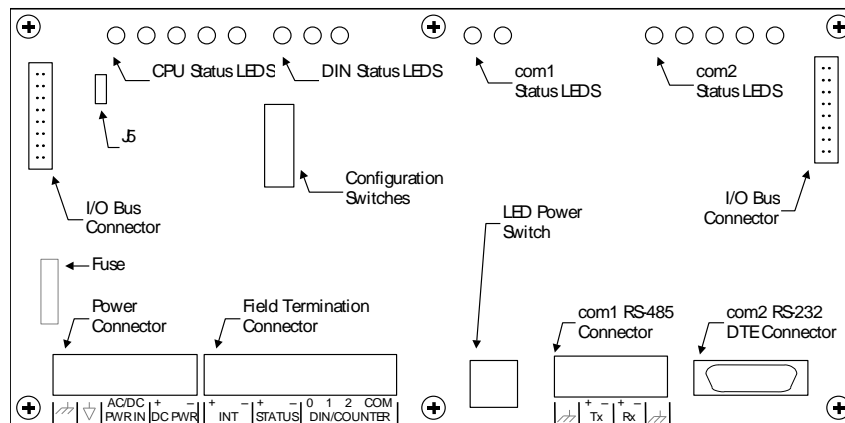

Figure 2: 5204 Controller Board Layout

Power Supply

Overview and Requirements

The SCADAPack controller is primarily a DC input powered device but can be powered with 16Vac under some conditions. The power supply requirements and setup is explained in the proceeding sections.

Voltage referred to as V_{rms} (or VAC on some products) indicates AC power. Voltage referred to as V indicates DC power.

The Controller board can be powered from a 12Vdc to 24Vdc power source applied to the DC PWR input or a 16Vac power source applied to the AC PWR IN input. With input power applied the Controller board power supply provides an internal 5V output to power the integrated I/O module and 5000 modules through the inter module cable (IMC).

When the controller board is powered with 16Vac power applied to the AC PWR IN input a limited amount of 24Vdc power is provided on the DC PWR terminals. The amount of 24Vdc power available is dependent on the amount of 5V output power used in the system. With the controller board consuming 200mA of current at 5Vdc, 360mA at 5Vdc is available to power external devices. However, this value linearly decreases to 80mA when the onboard power capacity is exhausted. See section **Sample Power Supply Calculations** in this user manual for details.

SCADAPack controllers can enter an extremely low power mode called sleep mode by switching off the 5V supply to I/O modules and many of the controller board circuits. Refer to the section **Sleep** section for more information.

Power Supply Input Connections

Input power is connected to the SCADAPack controller board in one of the following ways:

- A 16Vac source connects to the AC/DC PWR IN terminals on the Controller board and on the 5601 I/O Module. See Section **Recommended AC Power Supply Configuration** for an example of using a 16Vac transformer to power the SCADAPack controller.
- An 11-24Vdc source connects to the DC PWR terminals on the Controller board and on the integrated I/O Module. See Section **Recommended DC Power Supply Configuration** for an example of using a DC power source coming from an 11-24Vdc power source.

- A 5103 UPS Power Supply supplies 5Vdc to the controller board through the IMC cable and supplies 24Vdc to the integrated I/O module through the 24Vdc output. See **Recommended 5103 Power Supply Configuration** for an example of using the 5103 UPS Power Supply.

⚠ CAUTION

Power can be applied to either the AC/DC power input **OR** the DC power input. Damage to the power supply may result if power is applied to both inputs.

Recommended AC Power Supply Configuration

This configuration uses a single Class 2 transformer to power the controller board and any integrated I/O modules. 24V are available on the controller module connector P5 which can be used to power the analog circuitry for the analog input and output circuits on the integrated I/O module.

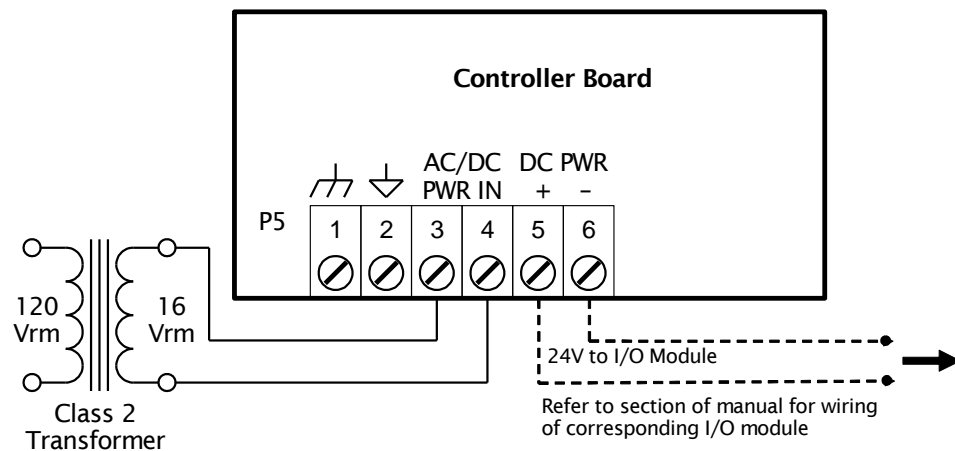

Figure 3: Recommended AC Power Supply Configuration

In this configuration, 24V with **limited** current is available on the two rightmost pins, labeled DC PWR, of the same P5 connector. This can be used to power the analog portion of the integrated I/O module although the available current may not be sufficient for the specific application. Please refer to user manual of the corresponding I/O module for wiring details and power availability on the DC PWR terminals in this configuration.

Recommended DC Power Supply Configuration

This configuration uses a single power supply or battery to power the controller board and the lower integrated I/O module. Refer to the **System Configuration Guide** for more information.

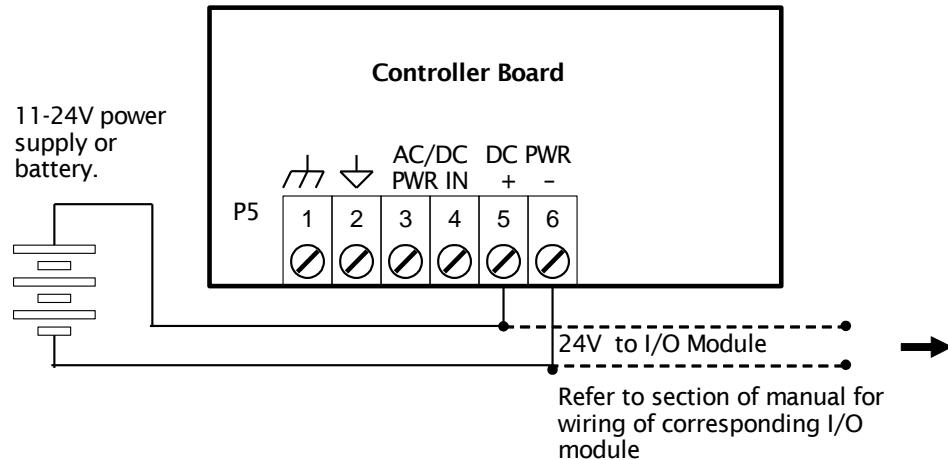

Figure 4: Recommended DC Power Supply Configuration

Recommended 5103 Power Supply Configuration

When additional power is required by the system, 5103 power supplies can be used in combination with the SCADAPack controllers. Refer to the **System Configuration Guide** for more information.

The 5103 power supplies can be connected anywhere *downstream* (to the right) of the controller. They will supply power to the modules downstream of them.

The Sleep Mode feature of the controller applies only to those modules powered by the controller.

The 5103 power supply may also be connected *upstream* (to the left) of any SCADAPack Controller, but only if the following conditions are observed:

- No power is applied to the power inputs of the controller board.
- A jumper is installed at position J5 (see the **Jumpers** section).
- The sleep mode feature is not used.

This configuration uses a 5103 Power Supply module to power a SCADAPack, SCADAPack Light or SCADAPack 32 controller. The 24VDC output from the 5103 powers the integrated I/O module. The 5103 power supply provides a 5V output to power the integrated I/O module, the controller board and 5000 modules through the IMC cables.

No connection is made to the AC/DC PWR IN or DC PWR terminals on the controller board.

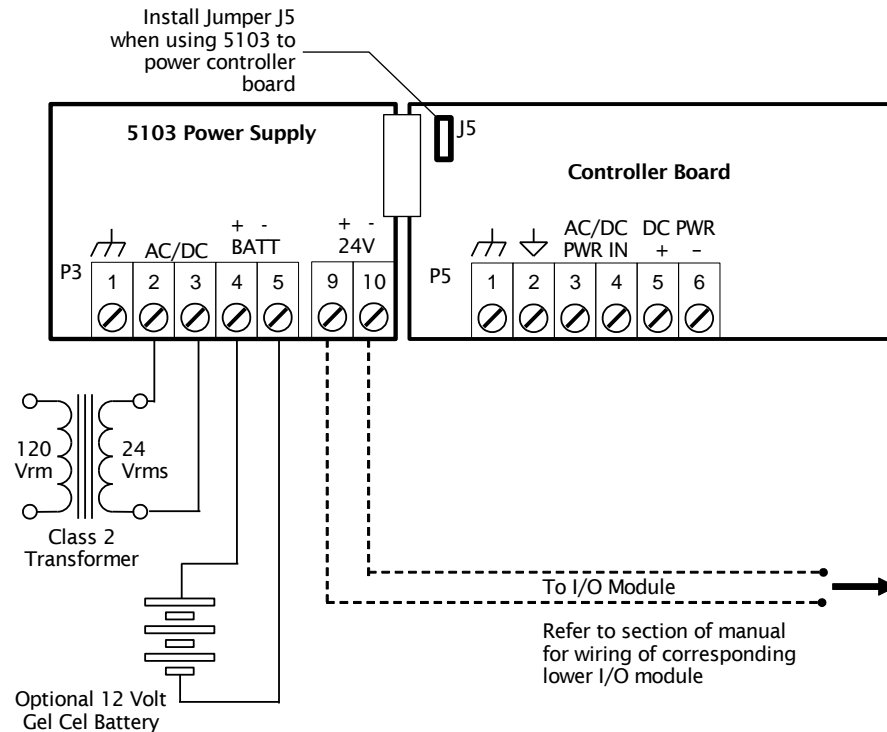

Figure 5: Recommended 5103 Power Supply Configuration

Sample Power Supply Calculations

SCADAPack P1

As illustrated in section **Recommended AC Power Supply Configuration**, the 520x controller board may be powering a 5601 I/O module as well as other 5000 modules.

The following table shows current requirements of a SCADAPack P1 controller (520x controller board with a 5601 I/O module):

	5V Current (mA)	24V Current (mA)
5203 Controller Board	175	0
5204 Controller Board	250	0
5601 I/O Module	20 + 40mA/relay	20 + 20mA/analog input
Analog Outputs	10	15 + 20mA/output

In the following example, a SCADAPack P1 with a 5203 Controller board, an integrated 5601 I/O module with analog outputs is powered using the **Recommended AC Power Supply Configuration** such that 24V will be available across the DC PWR terminals on connector P5 to power the integrated I/O board. This 24V is available for the both analog outputs and analog inputs that require power. In this example, both analog outputs and only 4 of the 8 analog inputs are being used. Further assume the 12 digital output relays will be on with LEDs enabled. In this scenario, the minimum current requirement for each module on the SCADAPack P1 is given in the table below.

	5V Current (mA)	24V Current (mA)
5203 Controller Board	175	0
5601 I/O Module	500	100
Analog Outputs	10	55
Total	685	155

The 5203 controller board has 1000mA available from the 5V supply. A minimum of 80mA is available from the 24V supply. Additional current is available from the 24V supply when the 5V is not loaded to its 1000mA maximum.

The total 24V supply current available is calculated as follows:

$$24V \text{ current} = 80 + ((1000 - \text{Total Current @ 5V}) \times 0.35)\text{mA}$$

$$= \underline{190.25\text{mA}}$$

where:

- 80 = Minimum current @ 24V
- 1000 = Maximum current @ 5V
- Total Current @ 5V = Sum of 5V current required for system
- 0.35 = Derating factor is a constant

In this example, where 685mA is required at 5V, 190.25mA is available on the 24V supply on connector P5. This is less than the 155mA required by the integrated 5601 I/O module. The SCADAPack P1 controller can therefore be powered using this method.

SCADAPack P1A

As illustrated in section **0-Recommended AC Power Supply Configuration**, the 520x controller board may be powering a 5604 I/O module as well as other 5000 modules.

The following table shows current requirements of a SCADAPack P1A controller (520x controller board with a 5604 I/O module):

	5V Current (mA)	DC Input Current (mA)
5203 Controller Board	175	0
5204 Controller Board	250	0
5604 I/O Module	15mA to 170mA See specifications for details.	10mA + 12/24V boost converter requirements. Can vary up to 550mA. The DC Input current depends on the actual DC Input voltage, whether the DC Input is boosted, and the load on the output.

Example 1

In this example a SCADAPack P1A with a 5203 Controller board, a 5604 I/O module with analog outputs is powered such that 24V will be available from DC PWR to power the integrated I/O board. DC Input voltage will not be boosted in the 5604 but is available for both analog outputs and the analog inputs. In this example, both analog outputs and 8 analog inputs are being used. Also assume the 32 digital I/O points will be on with the LEDs enabled.

	5V Current (mA)	24V Input Current (mA)
Controller Board	175	0
5604 I/O Module	170	10 + 200
Total	345	210

The controller board has 1.0A available from the 5V supply. A minimum of 80mA is available from the 24V supply. Additional current is available from the 24V supply when the 5V is not loaded to its 1000mA maximum.

The total available 24V supply current is calculated as follows:

$$\begin{aligned}
 \text{24V current} &= 80 + ((1000 - \text{Total Current @ 5V}) \times 0.25) \\
 &= 80 + ((1000 - 345) \times 0.25) = \underline{243.75\text{mA}}.
 \end{aligned}$$

where:

$$\begin{aligned}
 80 &= \text{Minimum current @ 24V} \\
 1000 &= \text{Maximum current @ 5V}
 \end{aligned}$$

Total Current @ 5V = Sum of 5V current required for system
 0.25 = Derating factor is a constant

The available current (243.75mA) is greater than the required current (210mA).

Example 2

In this example a SCADAPack P1A with a 5203 Controller board, a 5604 I/O Module with analog outputs is powered using the [Recommended Battery Configuration](#). Assume 32 digital I/O points will be on with the LEDs enabled. The application will be powered from a 12V battery. 24V will be generated from 12V using the 12/24V boost converter in the 5604. This 24V is available for both analog outputs and 8 of the analog inputs.

	5V Current (mA)	12V Input Current (mA)
5203 Controller Board	175	See calculation.
5604 I/O Module	170	See calculation.
Total	345	See calculation.

The 5604 DC Input supply current is calculated as follows:

$$\begin{aligned} \text{5604 DC Input Current} &= (24 \times \text{Total Current @ 24V}) / (12 \times 0.88) \\ &= (24 \times .20) / (12 \times 0.88) = \underline{455\text{mA}} \end{aligned}$$

where:

24 = 24V output
 12 = Input voltage
 Total Current @ 24V = Sum of 24V loads powered by the 12/24V boost converter (in mA).
 0.88 = Efficiency

The 5203 DC Input supply current is calculated as follows:

$$\begin{aligned} \text{5203 DC Input Current} &= (5 \times \text{Total Current @ 5V}) / (12 \times 0.85) \\ &= (5 \times 0.345) / (12 \times 0.85) = \underline{169\text{mA}} \end{aligned}$$

where:

5 = 5V power supply
 12 = Input voltage
 Total Current @ 5V = Sum of 5V loads powered by the 5232 (in mA).

0.85 = Efficiency

The total current delivered by the 12V battery in this example is:

$$455\text{mA} + 169\text{mA} = \underline{624\text{mA}}$$

It should be noted that in a battery-powered application such as this there are several opportunities to reduce the power consumption. There will be significant power savings when the LEDs are disabled. Switching VLOOP off under program control, when not required by the application will reduce the power required.

SCADAPack P1B

As illustrated in section **Recommended AC Power Supply Configuration**, the 520x controller board may be powering a 5606 I/O module as well as other 5000 modules.

The following table shows current requirements of a SCADAPack P1B controller (520x controller board with a 5606 I/O module):

	5V Current (mA)	DC Input Current (mA)
5203 Controller Board	175	0
5204 Controller Board	250	0
5606 I/O Module	30 to 600mA See specifications for details.	12

In the following example, assume the digital I/O points will be on with the LEDs enabled on a SCADAPack P1B with a 5203 controller board. The controller is wired using the [Recommended AC Power Supply Configuration](#) such that 24V will be available from DC PWR to power the integrated I/O board. This 24V is available for both analog outputs and 8 of the analog inputs.

	5V Current (mA)	24V Input Current (mA)
5203 Controller Board	175	0
5606 I/O Module	600	30 + 200mA
Total	775	230

The controller board has 1000mA available from the 5V supply. A minimum of 80mA is available from the 24V supply. Additional current is available from the 24V supply when the 5V is not loaded to its 1.0A maximum.

The total available 24V supply current is calculated as follows:

$$\begin{aligned}
 24\text{V current} &= 80 + ((1000 - \text{Total Current @ 5V}) \times 0.35) \\
 &= 80 + ((1000 - 775) \times 0.35) = \underline{158\text{mA}}
 \end{aligned}$$

where:

80 = Minimum current @ 24V
 1000 = Maximum current @ 5V
 Total Current @ 5V = Sum of 5V current required for system
 0.35 = Derating factor is a constant

The available current (158mA) is **less than** the required current (230mA) and as such it is not possible to operate this configuration from an AC source unless the number of current loops is reduced by 80mA.

System Grounding

In many applications, it is desirable to ground the system by connecting the system power supply common, to the chassis or panel ground.

On the 5203 or 5204 controller board, the logic ground (pin 2) and the negative terminal of the DC PWR or the 24V power source (pin 6) on connector P5 are referenced to the earth ground (pin 1).

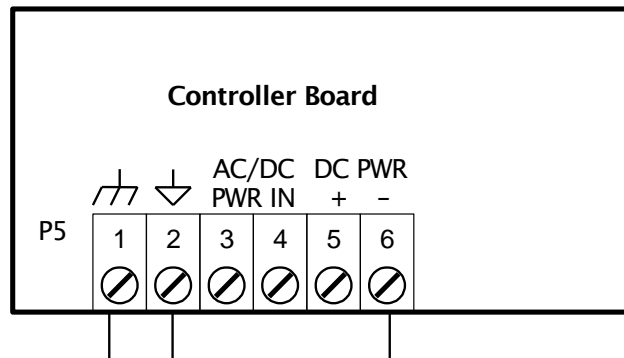

Figure 6: Grounding Configuration

Analog Inputs

The 520x controller board has two internal analog inputs, used by application programs to monitor controller board ambient temperature and the Lithium battery voltage. The 3.6V Lithium battery provides backup power to the RAM in case power is removed. These internal analog inputs are accessible by the user application program.

In addition, 5 or 8 analog input channels are available depending on the integrated I/O module. For example,

- The 5602 I/O module provides 5 single ended analog inputs.
- The 5601/5601A, 5604 or 5606 I/O modules provides 8 single ended analog inputs.

Refer to the hardware manual of your corresponding I/O module for wiring and configuration details of the I/O module analog input channels. Access of the controller board analog input data is covered in the rest of this chapter.

The ambient temperature input measures the temperature at the controller circuit board. It is useful for measuring the temperature of the controller's operating environment. The return value is of type integer and falls within the range -40°C to 75°C or -40°F to 167°F . Temperatures outside this range cannot be measured.

- For Telepace applications use the ***AIN Controller Temperature*** register assignment to read the ambient temperature in degrees C and degrees F.
- For IEC-61131-1 applications use the ***aintemp*** I/O connection to read the ambient temperature in degrees C and degrees F.

Please refer to the respective Telepace and IEC-61131-1 software manuals on how to assign the above registers.

The 3.6V lithium battery input measures the voltage of the battery that maintains the non-volatile RAM in the controller. The return value is in mV and falls within the range 0 – 5000 although a typical return value of 3500-3700mV is expected. A return value less than 3000mV indicates that the lithium battery requires replacement.

- For Telepace applications use the ***AIN Controller RAM Battery V*** register assignment to read the lithium battery voltage.
- For IEC-61131-1 applications use the ***ainbatt*** I/O connection to read the lithium battery voltage.

Analog Outputs

The 520x controller board by itself provides no analog output channels.

However, 2 analog output channels may accompany the integrated I/O module (if present), if this option was requested at time of purchase. The analog outputs produce 0-20mA of current but can easily be wired to provide an output voltage by connecting a load resistor across the output channel.

Refer to the hardware manual of your respective I/O module for details.

Digital Inputs

The 520x controller board has four Digital / Counter inputs i.e. the four digital inputs can also be used as counter inputs. One digital input, the interrupt input, can also be used to wake up the controller from sleep mode.

In addition, 16, 32 digital inputs or 32 universal digital inputs/outputs channels are available on the integrated I/O module, if present. For example,

- The 5601/5601A I/O module provides 16 digital input channels.
- The 5604 I/O modules provide 32 universal digital input/output channels.
- The 5606 I/O module provides 32 digital input channels.

Refer to the hardware manual of your corresponding I/O module for wiring and configuration details of the I/O module digital input channels. Wiring configuration or access of the controller board digital input data is covered in the rest of this chapter.

Digital/Counter Inputs

The controller board has three Digital / Counter inputs. These inputs are labeled **DIN/Counter** 0, 1 and 2 on the P4 terminal connector. The DIN/Counter inputs have one standard voltage range, 24V AC or DC, and operate as digital inputs and as counter inputs.

- For DC inputs the maximum input voltage is 30V and the minimum voltage to turn the input ON is 10V.
- For AC inputs the maximum input voltage is 24Vrms and the minimum voltage to turn the input ON is 10Vrms.
- For counter inputs the maximum frequency is 5 KHz with the filters off.

The **DIN/Counter** inputs can be used as both digital inputs and counter inputs in an application program.

- For Telepace applications use the **CNTR Controller Counter Inputs** register assignment to read the DIN/Counter inputs as counters and the **DIN Controller Digital Inputs** register assignment to read the DIN/Counter inputs as digital inputs
- For IEC-61131-1 applications use the **cntrCtrl** I/O connection to read the DIN/Counter inputs as counters and the **dinCtrl** I/O connection to read the DIN/Counter inputs as digital inputs.

Each of the three DIN/Counter inputs on the controller has a switch selectable filter, which limits the maximum input frequency. Filtering limits the maximum digital input or counter frequency to approximately 30Hz. SW1 is used to enable or disable filtering. Refer to Section **Digital Input Filters** section for filter selection information using SW3.

- Use a filter for 50 or 60Hz digital inputs and for low speed counting applications that experience contact bounce.
- Filtering is not required for high speed counting applications.

Wiring Examples

The figure below illustrates a wiring example where the DIN/COUNTERS channels are being used.

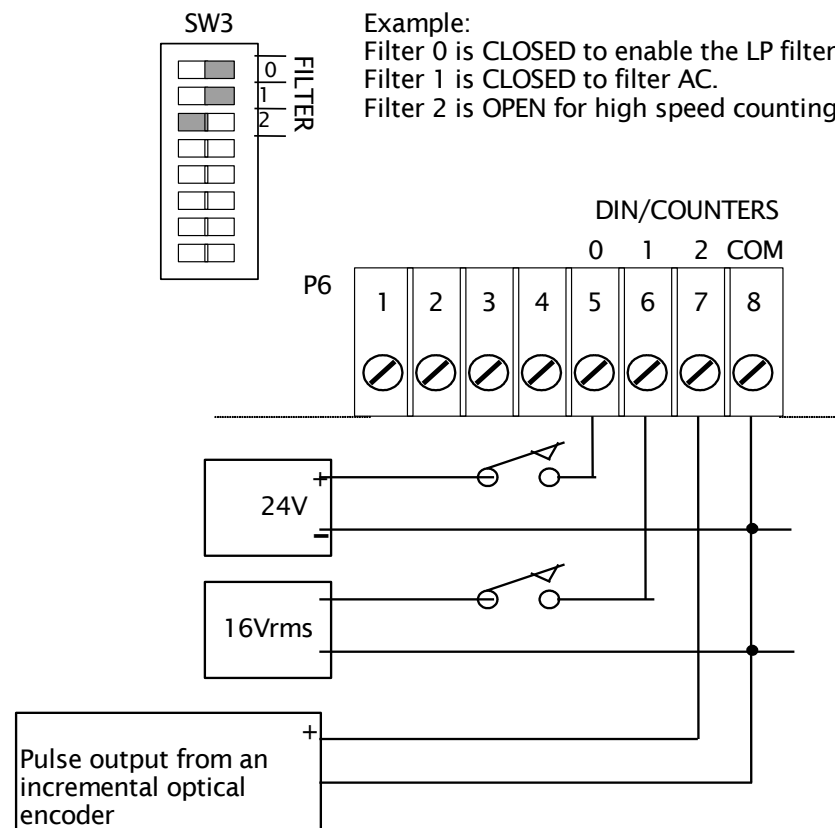

Figure 7: Digital/Counter (DIN/COUNTERS) Input Wiring

COUNTER 0 is being used as a counter in a low speed application. The low pass filter is enabled to remove the high frequency noise inherent in mechanical relay contacts.

COUNTER 1 is being used as a low speed counter with an AC enabling signal. The low pass filter is also enabled to filter AC.

COUNTER 2 is being used as a high-speed counter with the low pass filter disabled.

Interrupt Input

The controller board has one Interrupt digital input. This input is labeled **INT/Cntr** on the P6 terminal connector. This input operates as a DC digital input and as a counter input. The INT/Cntr input is also used to wake the controller from sleep mode. See section **Sleep** for more information on this feature.

For DC input the maximum input voltage is 28V and the minimum voltage required to turn the input ON is 2.5V. For counter input the maximum frequency is 500Hz.

The **INT/Cntr** input can be used as both a digital input and a counter input in an application program.

- For Telepace applications use the **CNTR Controller Interrupt Input** register assignment to read the INT/Cntr input as a counter and the **DIN Controller Interrupt Input** register assignment to read the INT/Cntr input as a digital input.
- For IEC-61131-1 applications use the **cntrint** I/O connection to read the INT/Cntr input as a counter input and the **dinint** I/O connection to read the INT/Cntr input as a digital input.

Wiring Example

The diagram below shows how to wire this input.

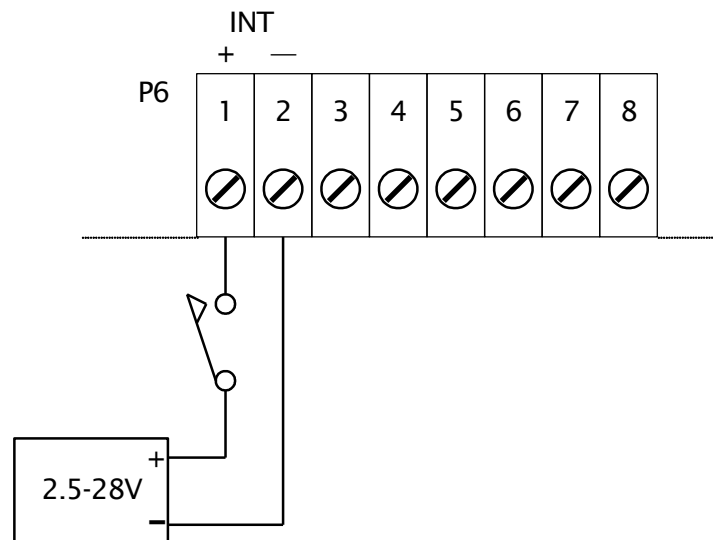

Figure 8: Interrupt Input (INT) Wiring

Digital Outputs

The 520x controller board provides a single digital (discrete) output channel which can be used to indicate the controller condition to an external device. In addition, 12, 16 dry contact digital outputs or 32 universal digital inputs/outputs channels is available on the integrated I/O module, if present.

- The 5601/5601A I/O module provides 16 digital input channels.
- The 5604 I/O modules provide 32 universal digital input/output channels.
- The 5606 I/O module provides 32 digital input channels.

Refer to the hardware manual of your corresponding I/O module for wiring and configuration details of the I/O module digital output channels. Information on the controller board digital output is covered in this rest of this chapter.

The controller board status output indicates a controller condition to an external device. The output is ON (capable of conducting current) during normal operation. The output is OFF (high impedance) during the following conditions:

- Power is removed.
- Controller board RESET.
- C application program defined conditions.
- I/O Module Indication.
- Register Assignment Checksum condition.

The status output is an optically isolated transistor. The following conditions apply:

- Observe output polarity.
- Limit the output current to 60mA during the OFF condition.
- Limit the output voltage to 30V during the OFF condition.

Wiring Example

A typical application of this output is shown in **Figure 9: STATUS Output Wiring**. In this scenario, STATUS is being used to energize a relay and the normally closed contacts of this relay are used to indicate a controller condition. The relay in this application has a 24V coil with greater than 400Ω resistance.

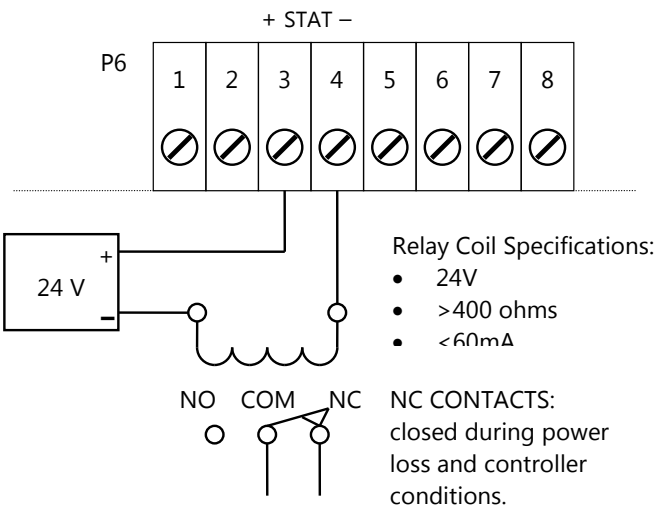

Figure 9: STATUS Output Wiring

Serial Communication

The 5203 controller board has two RS-232 serial ports, identified as COM1 and COM2. The 5204 controller board has one RS-485 serial port identified as COM1 and one RS-232 serial port identified as COM2. The integrated I/O module provides additional serial communication capabilities. Please refer to the section of the manual for each respective I/O module for details.

	5203 controller board	5204 controller board
COM1	RS-232 - DE-9P connector designated P3 on the Controller.	RS-485 – Terminal Connector P3 on the Controller.
COM2	RS-232 - DE-9P connector designated P4 on the Controller.	RS-232 - DE-9P connector designated P4 on the Controller.

RS-232 Serial Communication Ports

RS-232 wiring uses shielded cable. The shield should be connected to chassis ground at one point. Improperly shielded cables may result in the installation not complying with FCC or DOC radio interference regulations.

COM1

For 5203 controller boards COM1 is an RS-232 serial port. Connections are made through a DE-9P connector. The wiring and pin connections for this connector are described in Section ***DE-9P Connector for RS-232***.

The following table shows the serial and protocol communication parameters supported by COM1. These parameters are set from Telepace, IEC-61131-1 or from an application program running in the controller. Default values are set when a Cold Boot or Service Boot is performed on the controller.

Parameter	Supported Values
Baud Rate	300, 600, 1200, 2400, 4800, 9600, 19200, 38400. Default: 9600
Duplex	Full or Half Default: Full

Parameter	Supported Values
Parity	Odd, None or Even Default: None
Data Bits	7 or 8 Bits Default: 8 Bits
Stop Bits	1 or 2 Bits Default: 1 Bit
Receive Flow Control	ModbusRTU or None Default: ModbusRTU
Transmit Flow Control	Ignore CTS or None Default: None
Station	1 to 65534 Default: 1
Protocol	None, Modbus RTU, Modbus ASCII and optionally DF1 Or DNP. Default: Modbus RTU
Addressing Mode	Standard or Extended Default: Standard

COM2

Connections to COM 2 are made through a DE-9P connector. The wiring and pin connections for this connector are described in section ***DE-9P Connector for RS-232***.

The following table shows the serial and protocol communication parameters supported by COM1. These parameters are set from Telepace, IEC-61131-1 or from an application program running in the controller. Default values are set when a Cold Boot or Service Boot is performed on the controller.

Parameter	Supported Values
Baud Rate	300, 600, 1200, 2400, 4800, 9600, 19200, 38400. Default: 9600
Duplex	Full or Half Default: Full
Parity	Odd, None or Even Default: None
Data Bits	7 or 8 Bits Default: 8 Bits
Stop Bits	1 or 2 Bits Default: 1 Bit
Receive Flow Control	ModbusRTU or None Default: ModbusRTU

Parameter	Supported Values
Transmit Flow Control	Ignore CTS or None Default: None
Station	1 to 65534 Default: 1
Protocol	None, Modbus RTU, Modbus ASCII and optionally DF1 Or DNP. Default: Modbus RTU
Addressing Mode	Standard or Extended Default: Standard

DE-9P Connector for RS-232

RS-232 ports are 9-pin male D-sub-miniature (DE-9P) connectors configured as Data Terminal Equipment (DTE). A maximum cable length of 50ft (15.2m) is allowed. **Figure 10: RS-232 Port Connector** shows the pin connections on the RS-232 connectors.

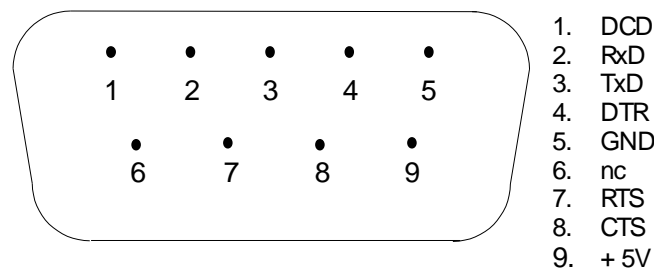

Figure 10: RS-232 Port Connector

Pin	Type	Description
Pin 1 DCD	input	The DCD led is on for a MARK level. (> +3V)
Pin 2 RxD	input	The level is SPACE (< -3V) on standby and MARK for received data. The RxD LED is lit for a MARK level.
Pin 3 TxD	output	The level is SPACE on standby and MARK for transmitted data. The LED is lit for a MARK level.
Pin 4 DTR	output	This pin is normally at a MARK level. This pin is at a SPACE level when DTR is de-asserted.
Pin 5 Ground		This pin is connected to the system ground.
Pin 6		This pin is not connected.

Pin	Type	Description
Pin 7 RTS	output	This pin is a MARK if full-duplex operation is selected for the port. This pin is set to a MARK just before and during transmission of data if half-duplex operation is selected. This pin is set to a SPACE when no data is being transmitted. The LED is ON for a MARK level.
Pin 8 CTS	input	This level is a MARK for the communication port to transmit data. When the attached device does not provide this signal, the controller keeps the line at a MARK. When the attached device does provide this signal, it sets CTS to MARK to allow the controller to transmit data. The LED is on for a MARK level.
Pin 9	output	This pin is connected to the 5V power supply. Leave this pin unconnected if not used.

RS-232 Wiring Examples

DTE to DTE without Handshaking

There are several methods for wiring the RS-232 COM port to DTE and DCE (Data Communications Equipment) devices. The simplest connection requires only 3 wires: RxD, TxD and signal ground. **Figure 11: RS-232 DTE to RS-232 DTE without Handshaking** shows a common RS-232 COM port to DTE device.

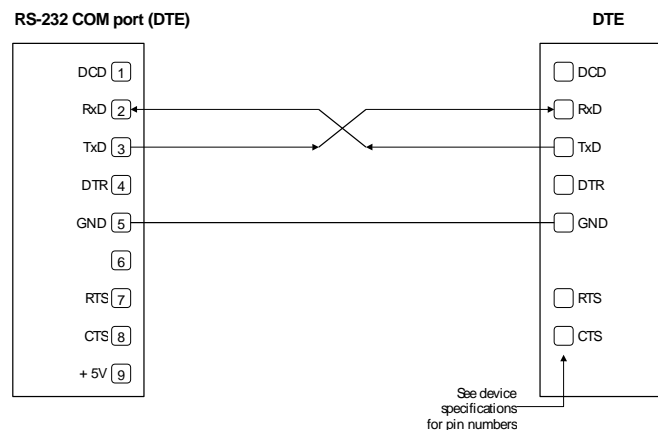

Figure 11: RS-232 DTE to RS-232 DTE without Handshaking

DTE to DTE with Handshaking

Some DTE devices may require hardware handshaking lines using the CTS and RTS lines. Less common are the DTR and DCD lines. The controller does not require these lines. Refer to the specifications of the external device for exact requirements. **Figure 12: RS-232 DTE to RS-232 DTE with Handshaking** shows a common connection of an RS-232 COM port with a DTE device requiring handshaking lines.

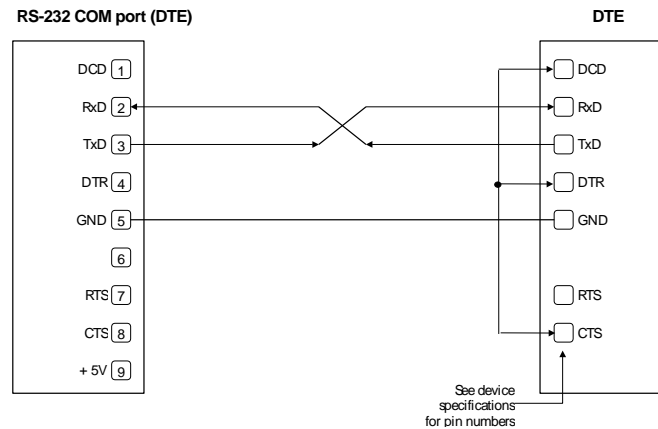

Figure 12: RS-232 DTE to RS-232 DTE with Handshaking

DTE to DCE with Handshaking

DCE devices require different wiring. The handshaking lines need to be connected. Many DCE devices are half duplex. Select half-duplex operation with these devices. **Figure 13: RS-232 DTE to RS-232 DCE** shows common connection of a SCADAPack with a DCE device requiring handshaking lines.

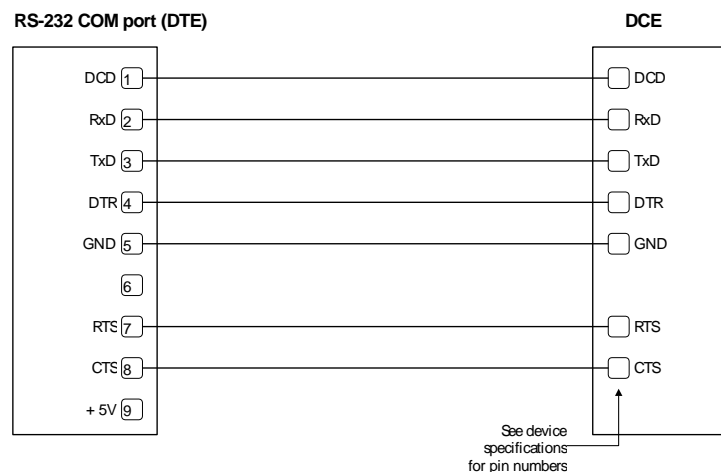

Figure 13: RS-232 DTE to RS-232 DCE

RS-485 Serial Communication Port

On the 5204 controller boards COM1 is an RS-485 serial port. Connections are made through a 6 pin terminal connector. The wiring and pin connections for this connector are described sections **Four Wire Mode** and the **Two Wire Mode** sections.

The following table shows the serial and protocol communication parameters supported by COM1 with the RS-485 serial connector. These parameters can be set from within Telepace, the IEC-61131-1 or from an application program running in the controller. Default values are set when a Cold Boot or Service Boot is performed on the controller.

Parameter	Supported Values
Baud Rate	300, 600, 1200, 2400, 4800, 9600, 19200, 38400. Default: 9600
Duplex	Full or Half Default: Full
Parity	Odd, None or Even Default: None
Data Bits	7 or 8 Bits Default: 8 Bits
Stop Bits	1 or 2 Bits Default: 1 Bit
Receive Flow Control	None or XON/XOFF Default: ModbusRTU
Transmit Flow Control	None or XON/XOFF Default: None
Station	1 to 65534 Default: 1
Protocol	None, Modbus RTU, Modbus ASCII and optionally DF1 Or DNP. Default: Modbus RTU
Addressing Mode	Standard or Extended Default: Standard

The RS-485 port transmits and receives differential voltages to other RS-485 devices. The RS-485 specification allows a maximum of 32 devices. It is recommended that the cable length should not exceed a maximum of 4000 feet (1200 m), and be terminated at each end.

The signal grounds of the RS-485 devices are not connected together but instead are referenced to their respective incoming electrical grounds. Wire the ground connections of the RS-485 devices to be within several volts of each other. The RS-485 port operates in two or four wire mode.

Four Wire Mode

Four-wire operation uses one pair of wires for transmitting data and a second pair for receiving data. The transmitting pair is connected to the terminals marked +TX and –TX on the termination block. The receiving pair is connected to the terminals marked +RX and –RX.

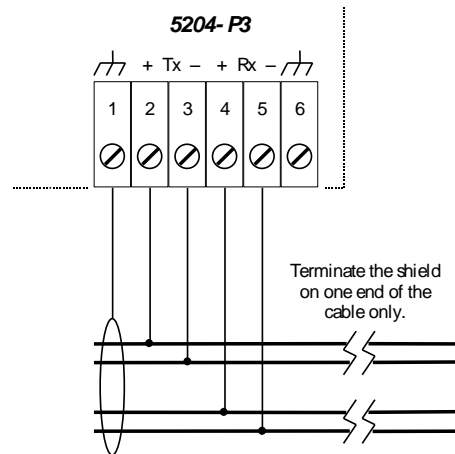

Figure 14: Four Mode Wiring to a RS-485 Port

Two Wire Mode

Two-wire operation uses one pair of wires for transmitting and receiving data. The +TX terminal is connected to the +RX terminal. The –TX terminal is connected to the –RX terminal. This pair of wires becomes the transmitting and receiving pair.

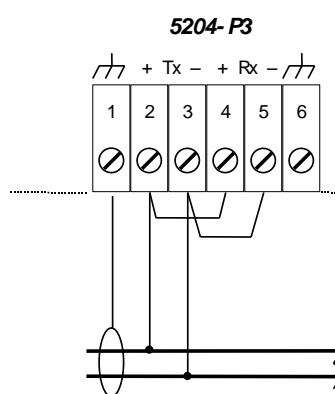

Figure 15: Two Mode Wiring to a RS-485 Port

Termination Resistors

Termination resistors are required on the first and last station on the RS-485 wire pair. The other stations should not have termination resistors. Resistors for receiver and transmitter termination are pre-installed on the 5204 controller board.

To connect the termination resistors:

- Install a jumper across the top two pins on J7 to terminate the RX pair.
- Install a jumper across the bottom two pins on J7 to terminate the TX pair.

To remove the termination resistors:

- Remove the jumper from across the top two pins on J7 to remove termination of the RX pair.
- Remove the jumper from across the bottom two pins on J7 to remove termination of the TX pair.

The 5204 controller board uses a traditional termination scheme with one 120Ω resistor across the line. Special receivers have been used such that the received data will be in an idle state for the following conditions on the RX pair:

- Open inputs.
- Terminated inputs.
- Shorted inputs.

This termination scheme may not be compatible with other RS-485 devices. RS-485 receivers that cannot tolerate a differential input voltage of 0V (line terminated but not driven) should be terminated with resistors that bias the line to known state during these conditions.

RS-485 Wiring Examples

Four wire mode

Four-wire operation uses one pair of wires for transmitting data and a second pair for receiving data. The transmitting pair is connected to the terminals marked +TX and –TX on the termination block. The receiving pair is connected to the terminals marked +RX and –RX. See the figure below for an illustrative example.

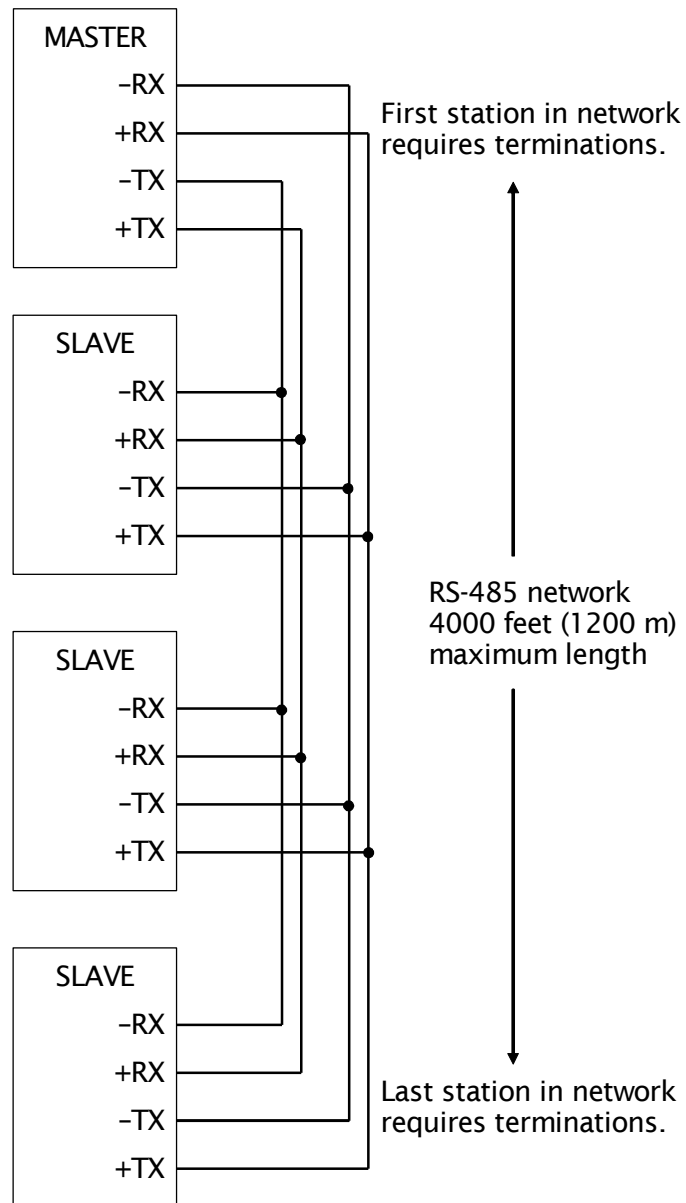

Figure 16: RS 485 Field Wiring – Four Wire Mode

Two wire mode

Two-wire operation uses one pair of wires for transmitting and receiving data. The +TX terminal is connected to the +RX terminal. The –TX terminal is connected to the –RX terminal. This pair of wires becomes the transmitting and receiving pair. See **Figure 17: RS 485 Field Wiring – Two Wire Mode** for an illustrative example.

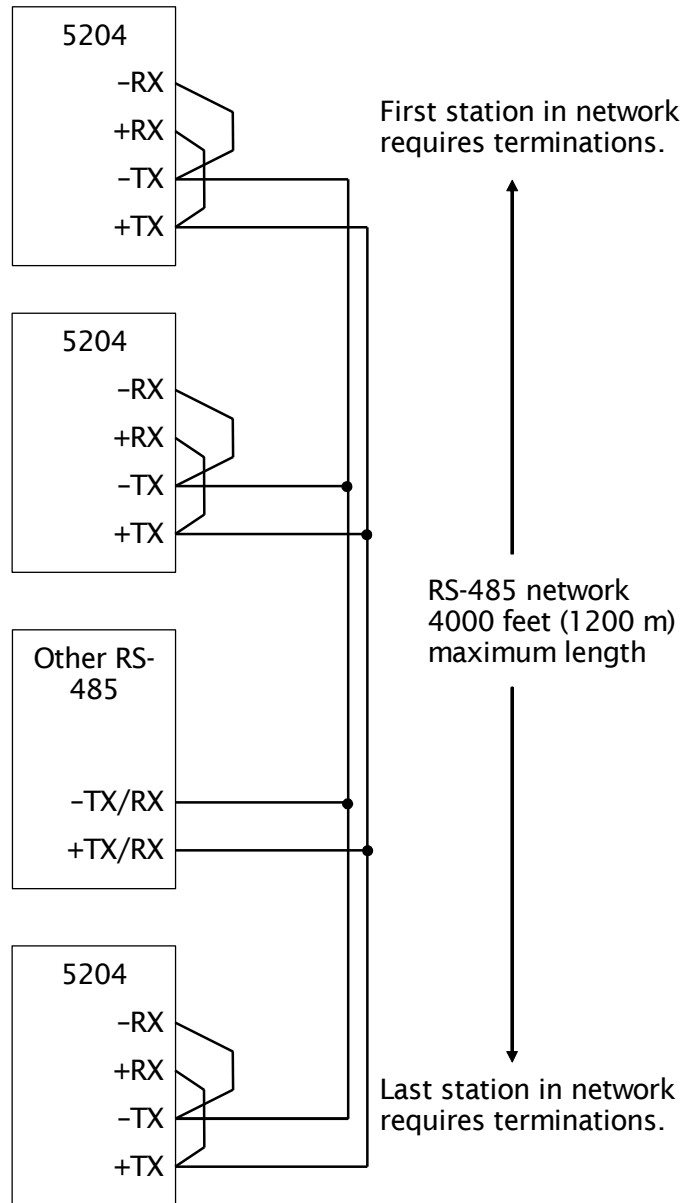

Figure 17: RS 485 Field Wiring – Two Wire Mode

Operation

Operating Modes

SCADAPack controllers may start up in RUN, SERVICE or COLD BOOT mode. Starting the controller in RUN mode automatically executes Telepace Ladder Logic and Telepace C programs in the controller memory. Starting the controller in SERVICE mode stops the programs to allow reprogramming and controller initialization. Starting the controller in the COLD BOOT mode initializes the controller and erases application programs.

Run

The RUN mode is the normal or default operating mode of the SCADAPack Controller. No action is required to select RUN mode. When power is applied to the controller board:

- The user defined serial communication parameters, for COM ports are used.
- If a Telepace Ladder Logic, or IEC-61131-1 application program is loaded in RAM, it is executed.
- If a Telepace C, or IEC-61131-1 C, application program is loaded in RAM and the program checksum is correct, it is executed.
- If there is no application program in RAM and there is an application program in flash ROM then the flash ROM program will be executed.
- The controller lock settings and password are used.

Service

SERVICE mode is used during application programming and maintenance work. When the SCADAPack controller starts in SERVICE mode:

- The default serial communication parameters are used (see section **Serial Communication** for the default parameters).
- The Ladder Logic or IEC-61131-1 program is stopped.
- The C program is stopped.
- Application programs are retained in non-volatile memory.
- The controller lock settings and password are used.

SERVICE mode is selected by performing a SERVICE BOOT using the following procedure:

- Remove power from the controller.
- Hold down the LED POWER button while applying power to the controller.
- Continue holding the LED POWER button until the STAT LED turns on.
- Release the LED POWER button.

If the LED POWER button is released before the STAT LED turns on, the SCADAPack controller will start in RUN mode.

Cold Boot

COLD BOOT mode is used after installing new controller firmware. When the SCADAPack controller starts in COLD BOOT mode:

- The default serial communication parameters are used (see section **Serial Communication** for the default parameters).
- The Ladder Logic or IEC-61131-1 program is erased.
- The C program is erased.
- The registers in the I/O database are initialized to their default values.
- The Register Assignment or I/O Configuration is erased.
- The controller is unlocked.

COLD BOOT mode is selected by performing a COLD BOOT using the following procedure:

- Remove power from the controller.
- Hold down the LED POWER button.
- Apply power to the controller.
- Continue holding the LED POWER button for 25 seconds until the STAT LED begins to flash on and off continuously.
- Release the LED POWER button.

If the LED POWER button is released before the STAT LED begins to flash, the SCADAPack controller will start in SERVICE mode.

Sleep

SCADAPack Controllers are capable of extremely low power operation when in sleep mode. The user's Telepace or IEC-61131-1 application program can enable and disable sleep mode using the SLP or SLEEP functions respectively. During sleep mode the following happen:

- Application programs stop executing.
- When J5 is not installed, the 5V power to much of the circuit is switched off. This includes the controller board and the lower 560x I/O module.

- When J5 is not installed, the 5V power to the I/O bus is switched off.
- The three counter inputs on the controller board continue to function.
- The real-time clock and wake timer continue to function.
- The interrupt input on the controller board continues to function.
- 24V DC power is not affected.

SCADAPack controllers can switch to sleep mode under control of the application program. Sleep mode is deactivated if one of the following conditions occur.

- Hardware RESET caused by power removed and applied to the controller.
- The LED POWER push-button is pressed.
- A real time clock wake up, defined by application program, occurs.
- A signal is applied to the interrupt (INT) input.
- Any of the controller board counters rolls over. This occurs after 65536 counts or pulses on each input.

LED Indicators

There are 18 LEDs on the 5203 controller board and 15 LEDs on the 5204 controller board. LEDs (except the 5V LED) can be disabled to conserve power. Refer to the **Led Power Control** subsection below for details.

The following table describes functions of the LEDs on the SCADAPack controller board.

LED	Function
5V	On when 5V power is present. Off when the 5V power is absent or the controller is in sleep mode.
RUN	On when the ladder logic program is executing.
LEDS	On when LED power is enabled.
STAT	Blinking when a register assignment checksum or I/O module condition exists.
FORCE	On when I/O points are forced.
DINS	On when a signal is applied to the corresponding digital input.
RX	On when receiving data on the corresponding serial port.
TX	On when transmitting data on the corresponding serial port.
CTS	On when the CTS input is asserted on the corresponding serial port.

LED	Function
RTS	On when the RTS output is asserted on the corresponding serial port.
DCD	On when the DCD input is asserted on the corresponding serial port.

Led Power Control

Power to the LEDs on the SCADAPack controller board, integrated or external I/O modules connected to the controller can be disabled to conserve power. This feature is particularly useful when the SCADAPack is used in solar powered or unattended installations.

The LED labeled LEDS on the controller board indicates the LED power state. It is on when the controller board enables LED power.

The LED POWER push-button toggles the LED power signal. Press the LED POWER push-button to toggle LED power from off to on, or from on to off.

The application program sets the default state of the LED power. The LED power returns to the default state 5 minutes after the LED POWER push-button is last pressed. The application program may change the default time and state.

LEDs are enabled when a controller board asserts the LED power signal. Power to the LEDs is provided by the /LEDON signal on the I/O bus. Asserting this signal will enable the LEDs. Releasing this signal disables the LEDs.

Some LEDs are unaffected by the /LEDON signal. Refer to individual module manuals for details. The digital input LEDs on the integrated I/O modules are an example of LEDs that are not affected by the /LEDON signal.

Jumpers

Some headers and jumpers on the controller board are reserved for manufacturing and test functions. The power supply jumper and the RAM Configuration jumpers may require user adjustment. However two user configurable jumpers allow the user to disable sleep mode and the RS-485 terminal connections.

The top cover will have to be removed to access the jumpers. Labels are located besides each jumper.

J5 Power Supply Jumper

The J5 jumper is removed when sleep mode is used otherwise it is installed.

RS-485 Termination Jumpers

A jumper is installed on the top two positions of J7 when the RS-485 Rx line requires a termination. A jumper is installed on the bottom two positions of J7 when the RS-485 Tx line requires a termination.

See the section **Termination Resistors** for additional information.

Status LED and Output

The status LED labeled STAT on the controller board indicates a controller condition that needs to be addressed. The STAT LED blinks and the STATUS output opens when such a condition occurs. An example on how to use the STATUS output is given in the section **Digital Outputs** above. The STAT LED turns off and the STATUS output closes when the condition clears.

The STATUS output remains open continuously when an controller condition is present.

The STAT LED blinks a binary sequence indicating condition codes. The sequences consist of long and short flashes, followed by an off delay of 1 second. The sequence then repeats. The sequence may be read as the Controller Status Code. A short flash indicates a binary zero. A long flash indicates a binary one. The least significant bit is output first. As few bits as possible are displayed, leading zeros are ignored. The application program defines the values of the condition codes.

The table below shows the meaning of the sequences.

Sequence	CONTROLLER STATUS CODE
Off	0 = Normal
1 Long	1 = I/O Module Indication
1 Short, 1 Long	2 = Register Assignment Checksum condition

I/O Module Indication

When the Status LED flashes the controller status code 1 (i.e. a long flash, once every second), one or more I/O module is not communicating with the controller. To correct this, do one of the following:

- Check that every module contained in the Register Assignment Table is connected to the controller. Check that the module address selected for each module agrees with the selection made in the Register Assignment Table.

- If a module is still suspect confirm the condition by removing the module from the Register Assignment Table. Write the changes to the controller. The Status LED should stop flashing.
- If a module is currently not connected to the controller, delete it from the Register Assignment Table. Write the changes to the controller. The Status LED should stop flashing.
- If unused modules are intentionally left in the Register Assignment Table, the I/O indication may be disabled from a selection box on the Register Assignment dialog.

Register Assignment Checksum

When the status LED flashes the controller status code 2 (i.e. a short flash then a long flash followed by a 1 second of delay), this indicates the register assignment is not valid. To correct this, initialize the register assignment from the Telepace software, or alternatively, perform a COLD BOOT as described in section **Operation** subsection of this manual. The status LED should stop flashing.

Configuration DIP Switches

The controller board has seven configuration dip switches combined in a single casing labeled SW3. There are three dip switches labeled FILTER 0, FILTER 1 and FILTER 2 which enable or disable the onboard low pass filter acting on the counter input channels. There are three dip switches labeled OPTION 0, OPTION 1 and OPTION 2 which enable the selection of the analog input and output ranges. The dip switch labeled H/W RST is used to reset the hardware. Details on these switches are provided in the upcoming sections.

The switches can be changed with the power applied. Digital filter, hardware reset action and analog input and output range selection changes take effect immediately. To select configuration switch functions:

- Remove the module cover and locate the configuration switches. See **Figure 1: 5203 Controller Board Layout** or **Figure 2: 5204 Controller Board Layout** for switch locations.
- Press down the right hand side of the switch to enable the switch function.
- Press down the left hand side of the switch to disable the switch function.

Digital Input Filters

Each of the three digital inputs on the controller board can be filtered. Filtering limits the maximum digital input or counter frequency to approximately 30Hz. Use a filter for 50 or 60Hz digital inputs and for low speed counting applications that experience contact bounce.

The FILTER 0, FILTER 1 and FILTER 2 switches control the input filter functions:

- To disable a filter, press down the left side of the switch (open).
- To enable a filter, press down the right side of the switch (closed).

FILTER 0, FILTER 1 and FILTER 2 are enabled by default.

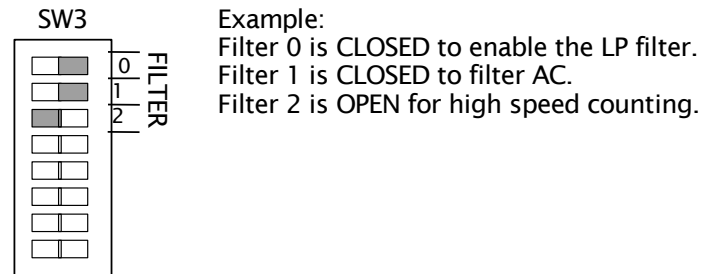

Figure 18: Low Pass Filter DIP Switches.

Hardware Reset

The 5203 or 5204 controller board can be programmed to reset the integrated lower I/O and any external 5000 I/O module when it resets. A reset could be caused by disconnecting power to the controller.

If the hardware reset function is enabled, a reset signal clears outputs to their power off state. If the hardware function is disabled, the outputs remain in their last known state until the controller restarts. By default, the controllers are shipped with the hardware reset function enabled.

The HW/RESET switch on SW3 controls the hardware reset function:

- To enable hardware reset, press down the right side of the switch (closed). This is the recommended setting.
- To disable hardware reset, press down the left side of the switch (open).

The hardware reset function is enabled by default.

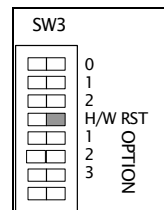

Figure 19: Hardware Reset DIP Switch

Analog Input Range Selection

The analog input channels of the integrated I/O modules on the SCADAPack controller can be configured for a 0% or 20% offset using DIP switch 'OPTION 1' on SW3. With the 0% offset, the input signal measurement range is 0-20mA in current mode or 0-5V in voltage mode. With the 20% offset, the input signal measurement range is 4-20mA in current mode or 1-5V in voltage mode.

On the SCADAPack P1 with the 5601 I/O module, select the 0% offset by pressing the left side of dip switch 'OPTION 1' on SW3 as shown in the figure below. Select the 20% offset by pressing the right side of the same switch.

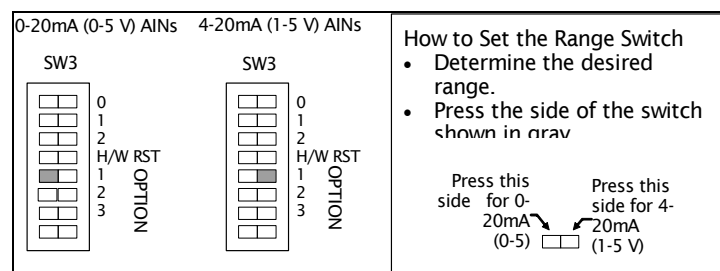

Figure 20: AIN Range DIP Switch

This function is not supported on the SCADAPack P1A controller with the 5604 I/O module. On the SCADAPack P1B controller with the 5606 I/O module, the settings are selected in software. See the **5606 Input Output Module** hardware manual of the corresponding I/O module for details.

The default setting for the analog inputs on the SCADAPack P1 and P1B is 0% offset or a measurement range of 0-20mA in current mode or 0-5V in voltage mode.

Analog Output Range Selection

The optional analog output channels of the integrated I/O modules on the SCADAPack controller can be configured for a 0% or 20% offset using DIP switch 'OPTION 2' on SW3. With the 0% offset, the output signal ranges from 0-20mA in current mode or 0-5V in voltage mode. With the 20% offset, the output signal ranges from 4-20mA in current mode or 1-5V in voltage mode.

On the SCADAPack P1 and P1A controllers, select the 0% offset by pressing the left side of DIP switch 'OPTION 2' on SW3 as shown in the figure below. Select the 20% offset by pressing the right side of the same switch. On the SCADAPack P1B, the settings are selected in software. See the **5606 Input Output Module** hardware manual of the corresponding I/O module for details.

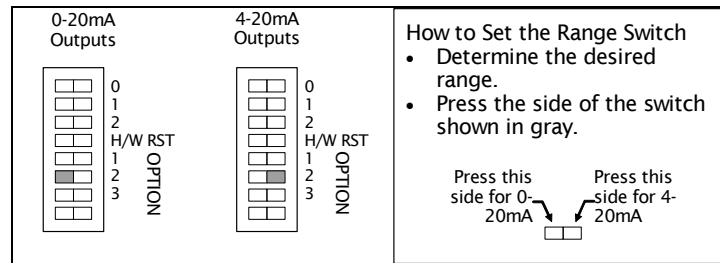

Figure 21: AO Range DIP Switch

The default setting for the AO channels is the 0% offset with signal ranges from 0-20mA in current mode or 0-5V in voltage mode.

Line Frequency Selection

The SCADAPack controller may select a 50 or 60 Hz line frequency for digital and analog input processing. Dip switch 'OPTION 3' on SW3 selects this option. On the SCADAPack P1 or P1A, press the left side of dip switch as shown in the figure below to select the 60Hz line frequency and the other side of the switch to select the 50Hz line frequency. On the SCADAPack P1B, select these settings when via software. See the **5606 Input Output Module** hardware manual of the corresponding I/O module for details.

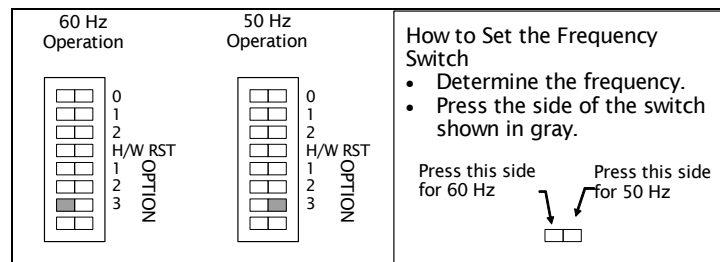

Figure 22: Input Frequency Processing DIP Switch

The 60Hz line frequency is enabled by default.

5000 Analog Input Module Compatibility

5000 analog input modules 5501 and 5521 require firmware release D (or more recent), if they are used with a controller board with a firmware release 1.23 (or more recent). Upgrade the older 5501 or 5521 I/O module firmware otherwise incorrect data may be returned from the module. Check the version of the firmware in your 5501 or 5521 analog input module against the table below.

Check These Parts	Part Number	Chip Location	Revision Required
5501 firmware <u>or</u>	TBUM160246 TBUM160303	U12 U12	Suffix D or later Suffix A or later
5521 firmware <u>or</u>	TBUM160246 TBUM160303	U12 U12	Suffix D or later Suffix A or later

Firmware Loading

Periodically the firmware for a controller is updated to add new features or provide bug fixes. As they become available new firmware versions may be downloaded from www.controlmicrosystems.com.

Allowed connections for firmware loading for a **SCADAPack** controller are **com1 or com2**.

Maintenance

The SCADAPack controllers require little maintenance. The 5V power LED indicates the status of the 5V supply. If the LED is off, and the 520x controller is powered using the integrated power supply, on board fuse F1 or F2 may require replacing. If the LED is off, and the 520x controller is powered using a 5103 power supply fuse F1 (5V) or F2 (24V) on the 5103 may require replacing. If the program is lost during power outages, the lithium battery may require replacement.

The analog input and output circuitry is calibrated at the factory and does not require periodic calibration. Calibration may be necessary if the module has been repaired as a result of damage.

If the SCADAPack controller is not functioning correctly, contact Control Microsystems Technical Support for information on returning the SCADAPack for repair.

WARNING

Field wiring, including the wiring to the RS-232 ports,

Remove power or confirm the area is known to be non-hazardous before changing field wiring, including the wiring to the RS-232 ports.

Failure to follow these instructions can result in death, serious injury or equipment damage.

Fuse

A 0.5A slow blow fuse is mounted under the cover. Refer to **Figure 1** for its location.

Remove power before replacing the fuse.

Replace a blown fuse with a fuse of the same rating. Under no circumstances should a fuse be bypassed or replaced with a fuse of a higher rating.

The fuse is a Littelfuse Nano-SMF. Littelfuse part number 218.500. This fuse is available from Control Microsystems.

In all cases investigate and correct the cause of the fuse failure before replacement. Common causes of blown fuses are wiring and excessive input voltages.

Refer to the DC power supply configuration subsection on each I/O module for recommendations on reducing the DC inrush current if fuse blowing is being experienced in DC power supply applications.

Lithium Battery

A small lithium battery powers the CMOS memory and real-time clock when input power is removed. The voltage of a functioning battery should be greater than 3.0V. An application program can monitor this voltage. Refer to the programming manual for details.

The battery should not require replacement under normal conditions. The shelf life of the battery is 10 years. The battery is rated to maintain the real-time clock and RAM data for two years with the power off. Accidental shorting or extreme temperatures may damage the battery.

Battery Replacement Procedure

The battery is plugged into the circuit board and held with a tie-wrap. If necessary it can be replaced with an identical battery available from Control Microsystems.

- Save the existing program running in the SCADAPack, if applicable.
- Remove power from the SCADAPack.
- Remove the SCADAPack top cover and locate the battery. It is found at the far right side of the circuit board.
- The battery is wrapped in place at the factory. This is to keep the battery from becoming disconnected during shipment. Remove the tie wrap using wire cutters.
- Remove the battery by gently lifting it straight up from the circuit board. The battery has two pins that mate with two sockets on the circuit board.
- Replace the battery. A replacement tie wrap is not necessary.
- Cold boot the controller. (Refer to section **Cold Boot** in this manual for the Cold Boot procedure.)

The controller may now be programmed.

Specifications

Disclaimer: Control Microsystems reserves the right to change product specifications. For more information visit www.controlmicrosystems.com.

General

I/O Terminations	6,8,9 and 10 pole, removable terminal blocks. 12 to 22 AWG 15A contacts
Dimensions SCADAPack	8.40 inch (213mm) wide 6.13 inch (155mm) high 2.80 inch (72mm) deep
Packaging	corrosion resistant zinc plated steel with black enamel paint
Environment	5% RH to 95% RH, non-condensing -40°C to 70°C -40°F to 158°F
Processor	M37702 16-bit CMOS microcontroller 14.7456MHz clock integrated watchdog timer
Memory	1024KBytes CMOS RAM 512kBytes flash ROM 1kBytes EEPROM
Non-volatile RAM	CMOS RAM with lithium battery retains contents for 2 years with no power
Clock calendar	±1 minute/month at 25°C +1/-3 minutes/month 0 to 50°C
Internal temperature	Measurement range -40°C to 75°C. Accuracy ±5°C. Measurement range -40°F to 167°F. Accuracy ±9°F.
Lithium battery Monitor	Accuracy ±0.2V.

Communications

Communication Ports, 5203 controller board	2 RS-232 serial ports (COM1, COM2) Data Terminal Equipment (DTE) DE-9P male connector
Communication	One RS-232 serial port (COM2)

Ports, 5204 controller board	Data Terminal Equipment (DTE) DE-9P male connector One RS-485 serial port (COM1) 2 wire half duplex 4 wire full or half duplex optional termination resistors
Baud Rates (COM1, COM2)	300, 600, 1200, 2400, 4800, 9600, 19200, 38400 default: 9600
Baud Rate (COM3) Where applicable	1200, 2400, 4800, 9600, 19200, 38400, 57600, 115200 default: 9600
Parity	none, even, or odd default: none
Word Length	7 or 8 bits default: 8 bits
Stop Bits	1 or 2 bits default: 1 bit
Duplex (COM1, COM2)	full or half with RTS/CTS control default: full
Duplex (COM3)	half with RTS/CTS control
Cable Length	RS-232 –maximum 50 ft (15.2 m) RS-485 –maximum 4000 ft (1200 m)
Protocol 5203 and 5204 Controller Boards	TeleBUS (compatible with Modbus RTU and Modbus ASCII) DF1 and DNP Protocols optional default: Modbus RTU
Protocol Modes 5203 and 5204 Controller Boards	slave, master, master/slave, store and forward

Visual Indicators

COM1(5203 controller), COM2	received data (Rx) LED	(Rx) LED
	transmitted data (Tx) LED	(Tx) LED
	clear to send (CTS) LED	(CTS) LED
	request to send (RTS) LED	(RTS) LED
	data carrier detect (DCD) LED	(DCD) LED
COM1 (5204 controller), COM3	received data (Rx) LED	(Rx) LED
	transmitted data (Tx) LED	(Tx) LED
5203 and 5204 Controller Boards	I/O module LED power status LED	

	Status LED (shows functional status) 5V power LED (LED power not applicable) Run LED Forced I/O LED Digital Inputs 0, 1 and 2 LEDs
Digital Inputs	DINS 0, 1, 2
Push-button	LED power toggle

Power Supply

Power Input	16Vrms \pm 20%
AC/DC PWR IN	14 to 30Vdc
DC power Input	30V maximum
DC PWR	10.0 to 11.5V turn on 9V typical turn off 12V at 10mA during Sleep Mode 12V at 600mA with 5V at 1.0A capacity
5 Volt Power Output, 5203 Controller Board	5V at 1.0A capacity 5V at 175mA required by 5203 controller
5 Volt Power Output, 5204 Controller Board	5V at 1.0A capacity 5V at 250mA required by 5204 controller
DC power Output	20-24V with 1.0Vp-p maximum ripple. 360mA available at 5V/0.2A, derate linearly to 80mA
16Vrms applied	available at 5V/1.0A
Efficiency	70%, 12V on DC PWR input

I/O Expansion Capacity

5000 I/O Expansion Capacity	Maximum 20 I/O modules.
------------------------------------	-------------------------

Digital Inputs

Input Points	3 Digital Input/Counter, 1 Interrupt opto coupler isolation
Digital Input, Counter	24Vrms/30V maximum input 10Vrms/10V minimum ON input 2V maximum OFF input Typical threshold voltage is 4 to 6V

	Typical input hysteresis 0.3V Typical input current 5mA at 10V 12mA at 24V
Counter Input Frequency	5kHz maximum with filter OFF 30Hz maximum with filter ON
Interrupt Input	30V maximum input 4V minimum ON input 2V maximum OFF input Input current 1mA at 5V 3mA at 12V 7mA at 24V
Interrupt Input Frequency	200Hz maximum

Digital Outputs

Status Output (STATUS)	Opto coupler open collector transistor 30V, 60mA opens on controller conditions
-------------------------------	---------------------------------------------------------------------------------------

Approvals and Certifications

Safety	<p>Non-Incendive Electrical Equipment for Use in Class I, Division 2 Groups A, B, C and D Hazardous Locations.</p> <p>UL Listed to the following standards:</p> <ul style="list-style-type: none"> • CSA Std. C22.2 No. 213-M1987 - Hazardous Locations. • CSA Std. C22.2 No. 142-M1987 - Process Control Equipment. • UL Std. No. 1604 - Hazardous (Classified) Locations. • UL Std. No. 508 - Industrial Control Equipment.
Digital Emissions	<p>FCC Part 15, Subpart B, Class A Verification</p> <p>EN61000-6-4: Electromagnetic Compatibility Generic Emission Standard Part2: Industrial Environment</p> <p>C-Tick compliance. Registration number N15744.</p>
Immunity	<p>EN61000-6-2: Electromagnetic Compatibility Generic Standards Immunity for Industrial Environments</p>
Declaration	<p>This product conforms to the above Emissions and Immunity Standards and therefore conforms with the requirements of Council Directive 2004/108/EEC (as amended) relating to electromagnetic compatibility and is eligible to bear the CE mark.</p> <p>P1 (5601/A) and P1B (5606) Models with digital inputs configured below 30Vdc/60Vac are eligible to bear the CE mark. The Low Voltage Directive is not applicable to these products in applications below 30Vdc/60Vac.</p> <p>The Low Voltage Directive is not applicable to the P1A (5604) Model and is eligible to bear the CE mark.</p>