

VELO WALL RACK 2D [BICYCLE STORAGE RACK]

MOUNTING INSTRUCTIONS

VELO WALL RACK MUST BE MOUNTED INTO WALL STUD.

1. Locate wall stud and put Wall Plate at the intended height and mark location of screw holes.
2. Drill 1/8" pilot hole on marks (IMPORTANT).
3. Line up pilot holes with screw holes on Wall Plate and install both heavy-duty screws (provided) tighten firmly.
4. Loosely attach Strip-Nut to arm using two M5 buttonhead screws with provided hex wrench and slide into slot on the side of the Wall Plate.
5. Adjust Rack Arms up and down to match frame style then firmly tighten M5 buttonhead screws.
6. Slide on End Caps onto Wall Plate to hide wall screws.
7. Loosen screws on Cradle Arms and adjust the in and out position to adjust distance of bike to the wall.
8. Re-tighten the Arm Screws then place bike in rack.

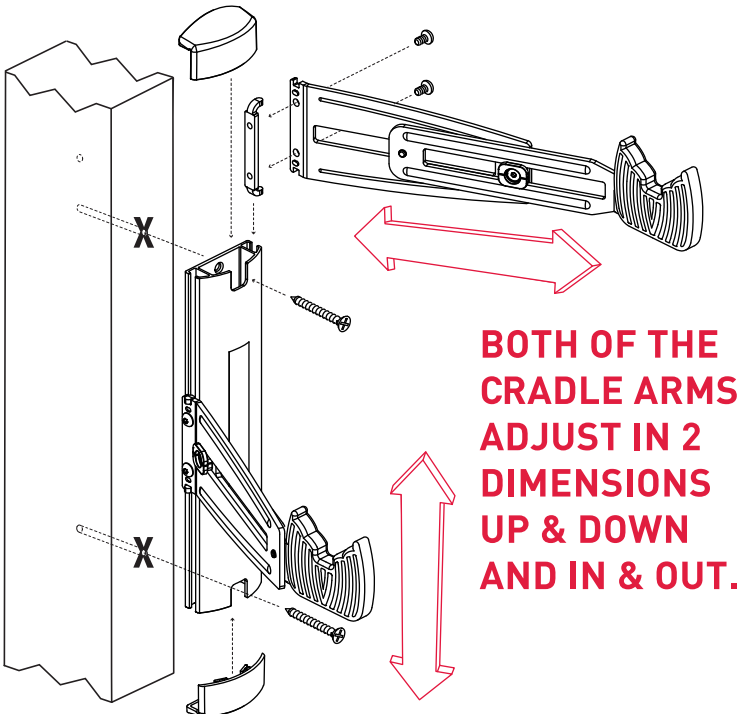

NOTE: After mounting rack, test thoroughly by weighting with equipment to insure the rack is properly installed and secure. Feedback Sports is not responsible for any damage resulting from improper installation.