



Watch our YouTube Videos for additional instructions:

Assembling the unit:

<http://kneewalkercentral.com/videos/essential/0a-Assembling-the-Knee-Walker-FS.mp4>

Breaking down the unit:

<http://kneewalkercentral.com/videos/essential/0b-Breaking-Down-the-Knee-Walker-FS.mp4>

**FOR HELP WITH ASSEMBLY PLEASE CALL
KNEE WALKER CENTRAL
(800)893-1264**



– SAVE THESE INSTRUCTIONS –

Do not attempt to adjust or operate your **FREE Spirit** KNEE AND LEG WALKER knee walker without carefully reading all instructions in this manual. If, after reading this manual, you have any questions, please call your health professional or place of purchase, otherwise injury or damage may occur.

SET UP INSTRUCTIONS

STEP 1. UNPACK

Remove all contents from carton. The carton should contain everything in the image to the right, as well as a 4mm Allen Wrench.

STEP 2. TILLER ASSEMBLY

The tiller and handlebar are attached to the frame with two brake cables. Prior to mounting the tiller to the frame, make sure the brake cables are not twisted or kinked. Remove the tiller hardware from the post at the front of the frame, then slide the end of the tiller onto the post. Make sure the Safety Lock Lever (View 1 of Figure 3) is toward the front of the walker. Slide a Thin Washer ② onto each bolt ① and insert the bolts through the tiller from the front. Slide a thick washer ③ onto the end of each protruding bolt and fasten the assembly with two lock nuts ④, as shown in Figure 2. The assembly must be fully tightened with a 4 mm Allen wrench and a 10 mm wrench (not provided).

To adjust the height of the handlebar, remove the height adjustment knob and bolt from the tiller, move the handlebar to the desired height, then reinsert the bolt into the tiller (through the hexagonal hole on the left side) and screw the knob onto the bolt. Make sure the knob is fully tightened.

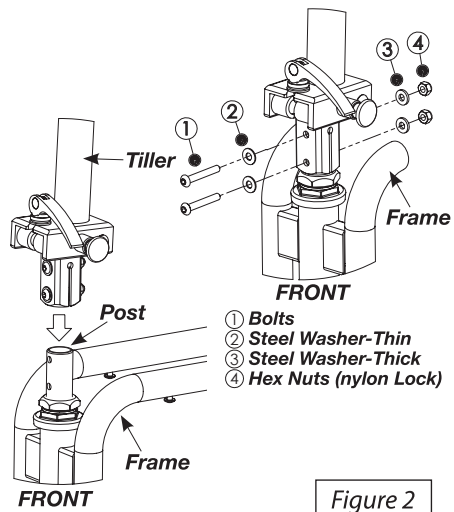
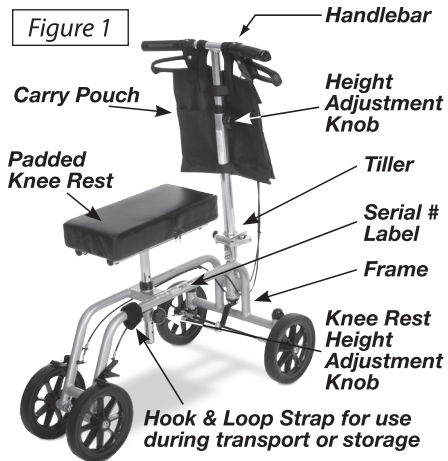

Do not use the walker if there is apparent damage and/or if parts are missing.

Please call place of purchase for repair/return information.

SET UP INSTRUCTIONS *(continued)*

STEP 3. PADDED KNEE REST INSTALLATION

Remove the knob, bolt, and washers from the padded knee rest. Slide the padded knee rest into the knee rest bracket hole in the center of the frame. Holding it at the height recommended by your medical professional, insert the bolt through the hexagonal hole on the left side of the knee rest bracket. Then, slide the flat washer and lock washer onto the protruding bolt. Screw the knob onto the bolt and tighten securely.

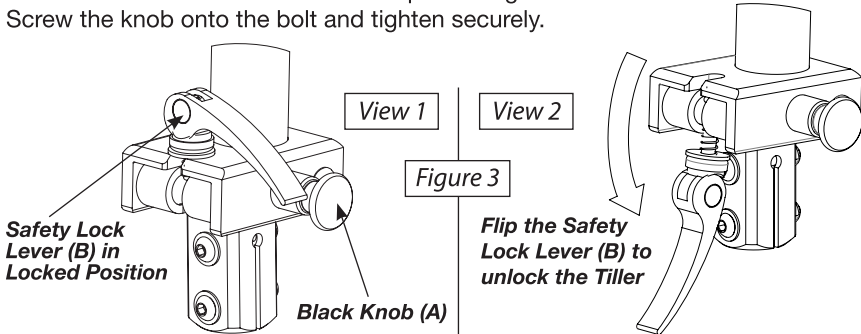
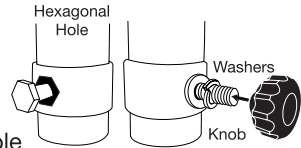

STEP 4. OPERATING THE TILLER FOLDING MECHANISM

The tiller folding mechanism is in the locked position when shipped from the factory, as shown in View 1 of Figure 3. If the tiller was not received in the locked position or you would like to fold the tiller, follow the tiller folding instructions below:

1. TO FOLD THE TILLER - Grasp the end of the safety lock lever **(B)** and open it by pulling up. Then, flip the entire safety lock lever assembly forward, as shown in View 2 of Figure 3. Pull the black knob **(A)** out until it stops, while simultaneously using your other hand to fold the tiller toward the padded knee rest. Release the black knob **(A)** and secure the folded tiller to the frame with the hook and loop strap.

2. TO RAISE THE TILLER - Unfasten the hook and loop strap and raise the tiller to the vertical position. The positioning pin attached to the black knob **(A)** will automatically spring into place. Flip the entire safety lock lever assembly up into the slot of the tiller, grasp the end of the safety lock lever **(B)** and press down on the lever until it stops, as shown in View 1 of Figure 3. Do not try to force the safety lock lever past its stopping point. Make sure the tiller is stable, then secure the hook and loop strap to the frame below the knee rest.

⚠ CAUTION: DO NOT TAMPER WITH THE SAFETY LOCK LEVER ASSEMBLY (B). IT IS ADJUSTED AT THE FACTORY TO PROVIDE THE TENSION NECESSARY TO SAFELY LOCK THE TILLER. IF THE TILLER FEELS LOOSE WHEN THE SAFETY LOCK LEVER (B) IS IN THE LOCKED POSITION (VIEW 1 OF FIGURE 3), CONTACT THE PLACE OF PURCHASE FOR SERVICE OR REPAIR.

⚠ ATTENTION: The Black Knob **(A)** is for positioning ONLY and is NOT the safety lock for the tiller. The Safety Lock Lever **(B)** **MUST** be properly folded into the locked position for your safety. The Back Knob **MUST** be pulled out prior to folding down the tiller.

SET UP INSTRUCTIONS (continued)

DETAILS OF TILLER LOCKING ASSEMBLIES

If, for any reason, the threaded rod ① loosens from the rotating rod ②, the spring ③ may cause the assembly to separate. If this occurs, try to locate all of the components (shown in Figure 4) and contact the place of purchase or Essential Medical Supply, Inc.® (1-800-826-8423) for assistance. DO NOT attempt to use the walker without the complete tiller lock assembly.

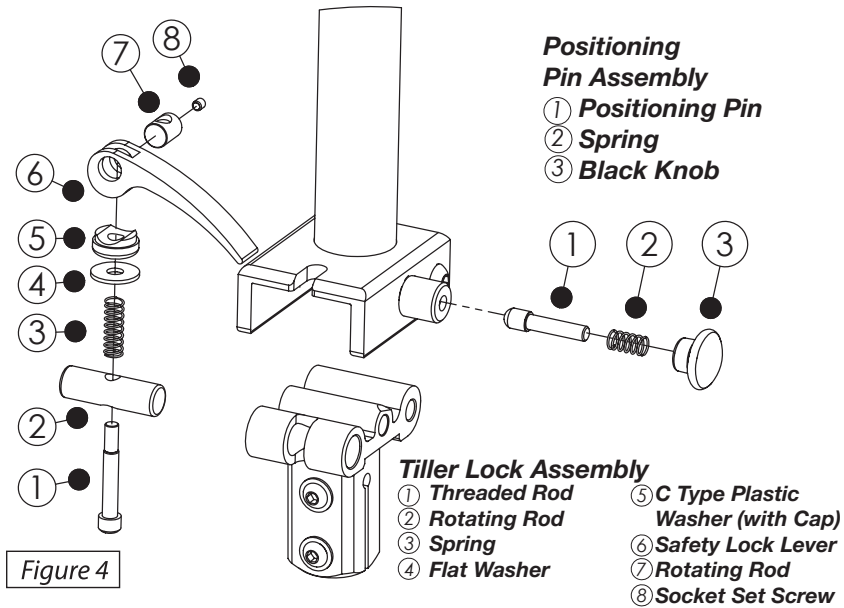

USER WARNING - Read Immediately



- Do NOT use on stairs or escalator.
- Do NOT let someone push you. The FreeSpirit® is not designed to be used as a wheelchair.
- Do NOT stand on your unit.
- Children under twelve should not use the unit.
- Always lock loop hand brakes when getting off or on the unit.
- This unit is not recommended for elderly or infirm individuals.
- Do NOT use the unit over curbs or rough terrain.
- Proper apparel should be worn at all times when operating the device. Loose fitting pants, long skirts and any other articles that could get caught in the wheels, as well as sandals, flip-flops and open toed shoes should not be worn.

USE and SAFETY INFORMATION

Maximum Weight Limit: 400 lbs

- You should receive complete operating instructions from your medical equipment provider prior to use. If you are not comfortable using the unit or do not understand how to operate the safety lock lever, contact your provider immediately.
- When you start using your FreeSpirit®:
 - Practice turns slowly until you get the “feel” of your unit.
 - Do NOT mount or dismount on an incline.
 - Stay on hard surfaces and off grass and sand.
 - Do NOT use on or over stairs.
- Care should be taken to ensure that all hand and height adjustments are secure, and that all wheels are in good working order before using this unit.
- Make sure all height adjustment knobs are fully tightened. Test unit for stability before applying full weight to knee rest and hand grips.
- Test the loop brakes before operating the unit. When the loop brakes are locked, the brake plates should prevent the rear wheels from rotating. If the wheels are able to rotate, please return the unit back to the place of purchase for adjustment. The rear wheels should turn freely when the loop brakes are not engaged. (Refer to page 5 for hand brake operation)
- The purpose of the positioning pin assembly is to position the tiller in the correct location while the user locks the safety lock lever. The FreeSpirit® must not be used when the safety lock lever is not in the locked position.
- All wheels MUST be in contact with the floor at all times during use. This will ensure the unit is properly balanced.
- To prevent tipping, which may cause damage to the unit or bodily injury:
 - **DO NOT** attempt to reach objects if you are kneeling on the knee rest.
 - **DO NOT** hang anything from the frame of your unit. Items should be placed in the tote bag designed for your unit.
 - **DO NOT** add to your load when you are using the unit.
The above situations will cause a change of weight distribution and may cause the unit to tip, resulting in injury or damage. Always use EXTREME caution when reaching for any object.
- The knee rest is not designed for sitting or supporting full body weight.
- This is a walking aid only and not intended for use as a transportation device or a toy scooter.
- If the hand grips are exposed to extreme temperatures (above 100° F or below 32° F), high humidity and/or water, ensure the hand grips DO NOT rotate on the handlebars prior to using the unit. Otherwise, damage or injury may occur.
- Replace tires when worn or damaged.

HAND BRAKE OPERATION

Always operate the left and right hand brakes at the same time.

■ To Slow or Stop Unit Temporarily

Pull up on the loops with your fingers until the walker slows or stops.

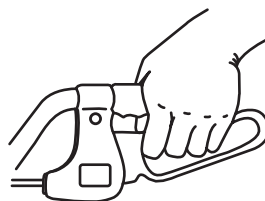

■ To Lock Wheels in Position

Press down on the rounded part of the loop with the palm of your hand until you feel it lock into place.

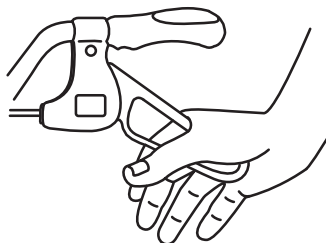

■ To Release Wheel Locks

Push up on the bottom of the loop with the palm of your hand. When the loop moves back to the neutral position, the wheel is unlocked.

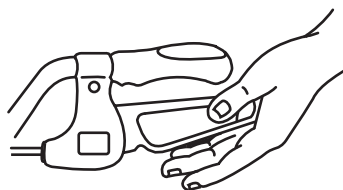

WARNING



Both loop brakes must be locked when getting on or off the unit.

Brakes are subject to wear and tear. If the brake plate does not contact the wheel and/or a loop brake cracks, breaks or does not function properly, return to a service center immediately.

Failure to do so may result in damage to your unit or bodily injury.

CLEANING, CARE & MAINTENANCE

MEDICAL EQUIPMENT PROVIDERS:

For walkers that are used for rental purposes, periodic maintenance and all weekly and monthly checks should be performed before each rental period.

Periodic maintenance for walkers that are sold for private use should be scheduled by the customer.

New replacement parts are available to providers from Essential Medical Supply, Inc[®]. Use only new parts for repairs and replacements.