

8 7 6 5 4 3 2 1

D

1.1  
LEFT AND RIGHT SIDE TOP CHANNEL  
QTY 2

1.2  
FRONT AND REAR TOP ANGLE  
QTY 2

C

1.3  
LEFT AND RIGHT SIDE MEMBER ANGLE  
QTY 2

1.4  
FRONT AND REAR CROSS MEMBER ANGLE  
QTY 2

B

LEG  
QTY 4

3  
SCREW HEX HD  
1/4-20UNCX0.75  
F593C  
QTY 32

4  
NUT HEX  
1/4-20UNC  
F594C  
QTY 32

A

5  
FLAT WASHER  
QTY 64

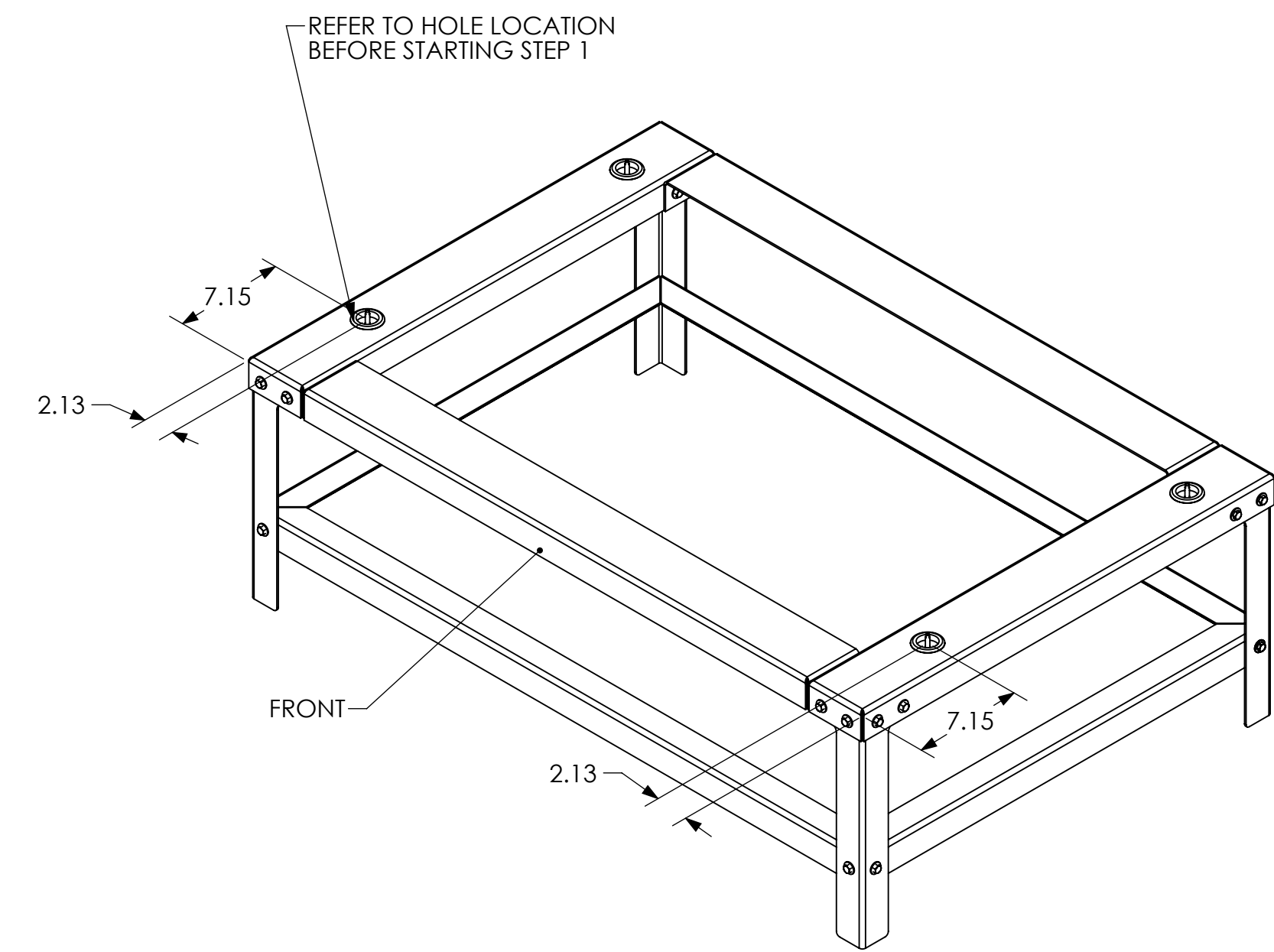

LAC2-18-8

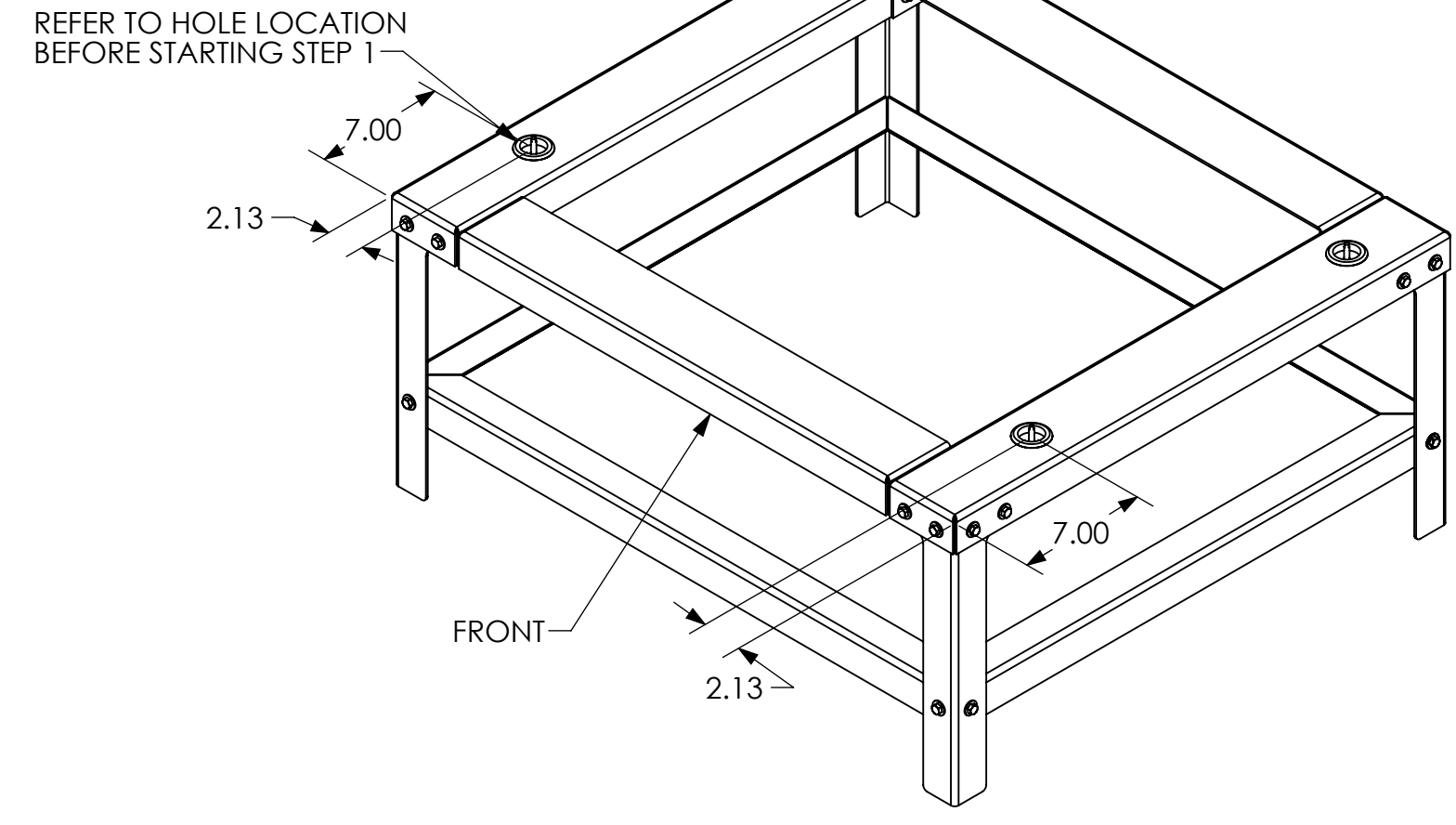

LAC2-12-8

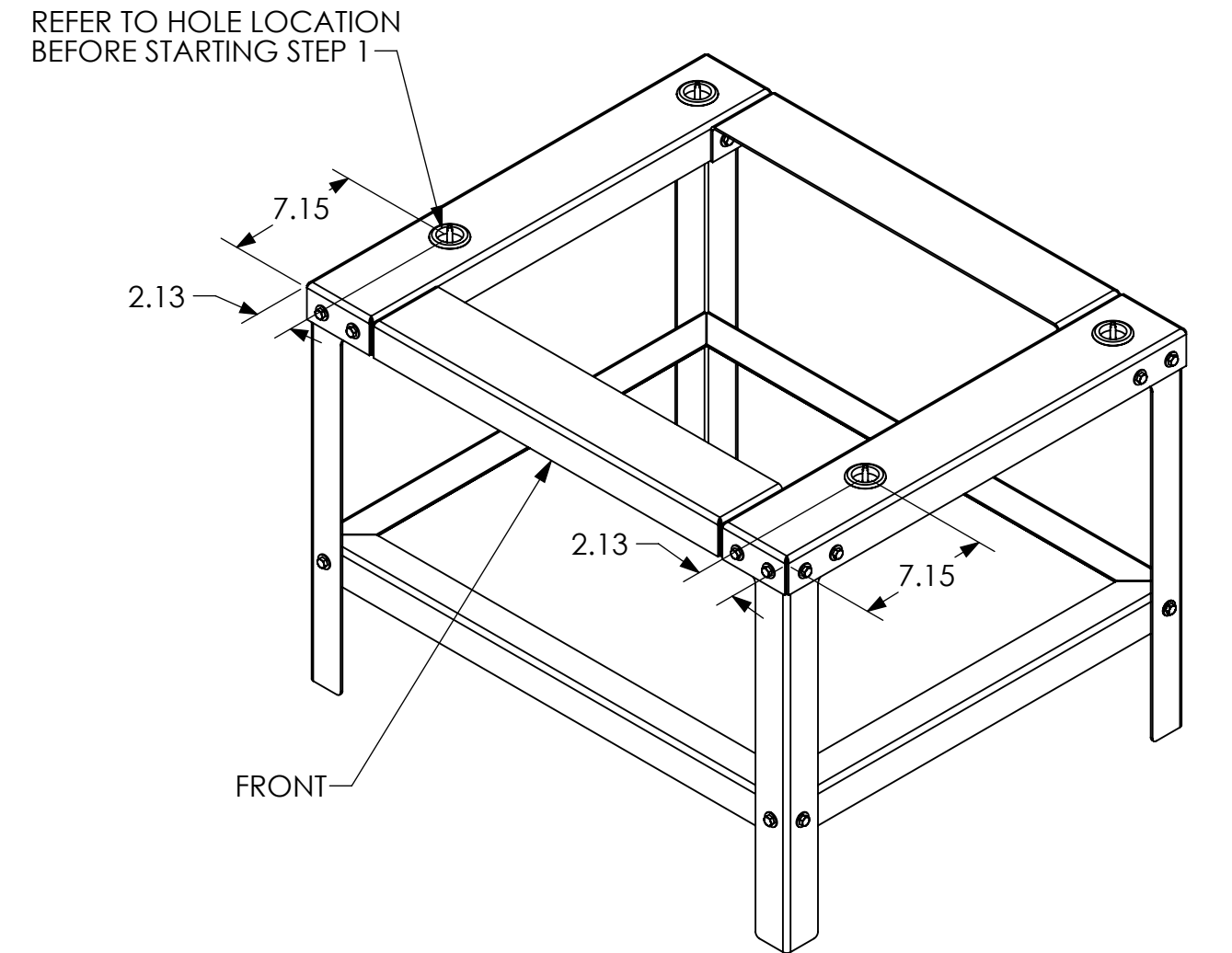

LAC1-67-8

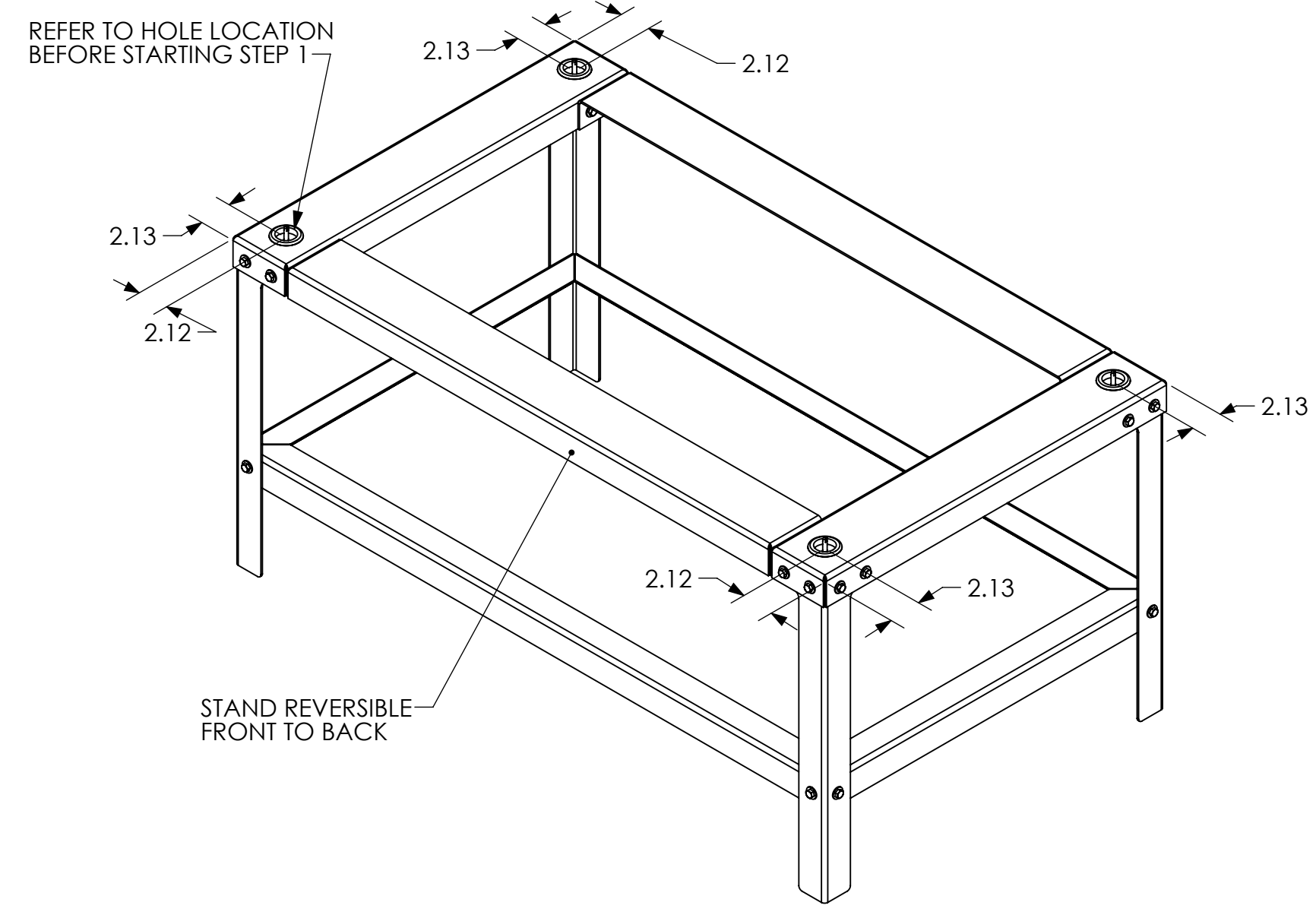

R\_D1-42

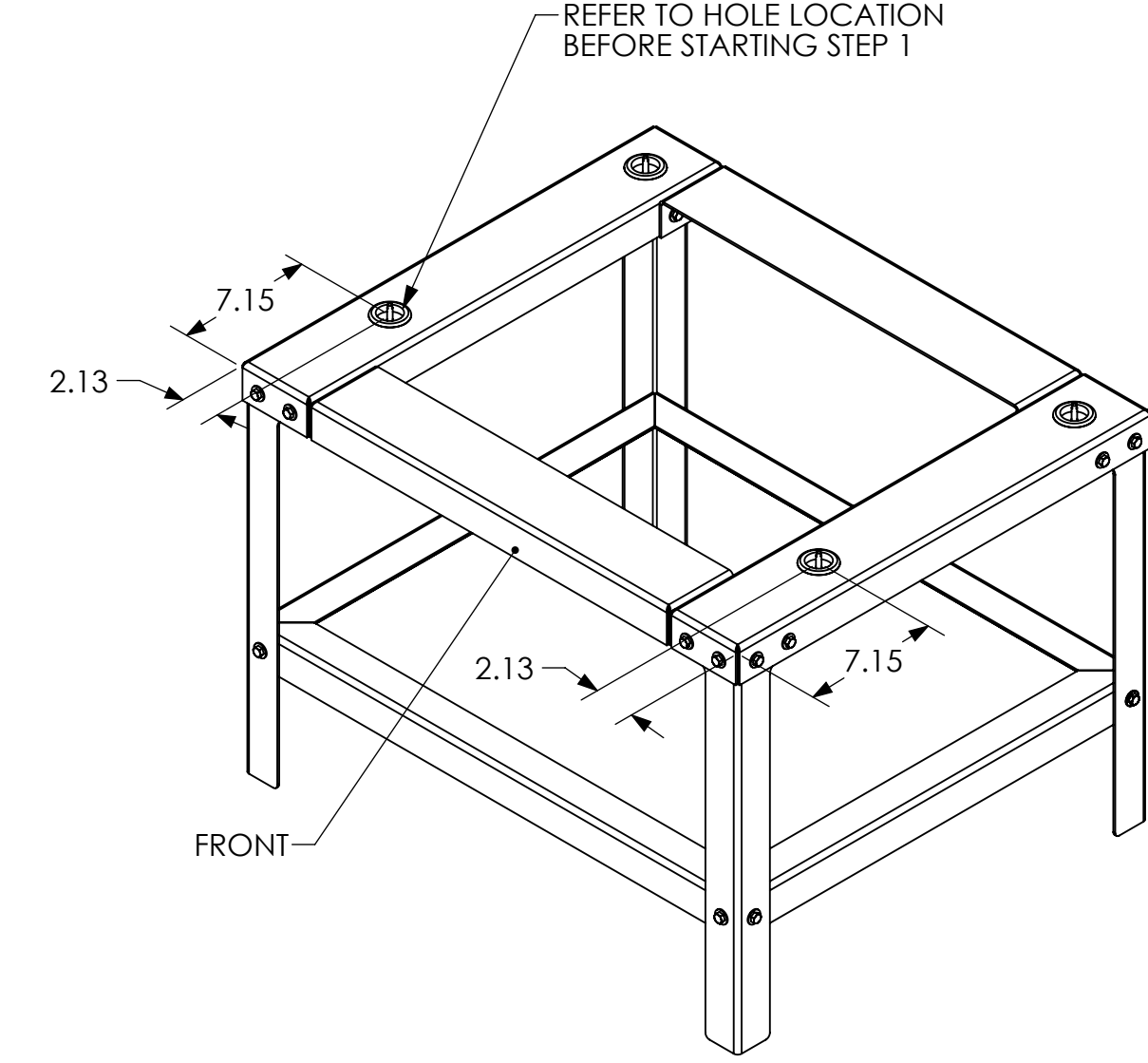

LAC1-38-8

- NOTE:
- TOOLS REQUIRED:
    - 7/16" SOCKET WRENCH
    - 7/16" OPEN END WRENCH
    - TORQUE WRENCH (IN-LBS)
  - ASSEMBLE ALL ITEMS THROUGH ALL STEPS LOOSELY TOGETHER UNTIL COMPLETED FINAL STEP.
  - TORQUE ALL HARDWARE TO 75-100 IN-LBS (6-8 FT-LBS)
  - REFERENCE INSTALL KIT 404050 TO INSTALL OVEN ONTO STAND.

REV.	DATE	BY	DESCRIPTION	ECO #
E	7/18/2019	JRS	SH 1: BALLOON ITEM 3 WAS ITEM 1. REORDERED NOTES AND ADDED A NEW NOTE 1. ADDED TORQUE IN FT-LBS ON NOTE 3. SH 2: ON LBB1-69 ADDED REVERSIBLE FRONT AND BACK. LBB1-23 ADDED GROUWNET AND SCREWS TO MODEL. SH 5: ADDED WORDS "AND SIDE" TO STEP 3 DESCRIPTION.	1900108
D	6/7/2019	HV	UPDATES AFTER 1ST ARTICLE. ESP F593C SCW.	1900108
C	5/6/2019	JRS	SH 6 OF 6 CORRECTED TITLE	UPDATE
B	5/1/2019	JRS	SH 1: ADDED NOTE 3. RE-ORDER PICTURE LIST TO MATCH STAND BOM ORDER. ADDED BALLOONS TO MATCH SH'S 3 THRU 6 UPDATED ASSEMBLY VIEWS	UPDATE

UNLESS OTHERWISE SPECIFIED DIMENSIONAL TOLERANCES

DECIMALS  
XX ± .030  
.XXX ± .005

THE DESIGN SHOWN ON THIS DRAWING IS THE EXCLUSIVE PROPERTY OF ITW EAE. IT IS SUBMITTED WITH THE UNDERSTANDING THAT IT IS NOT TO BE USED FOR ANY PURPOSE OR ITS CONTENTS DISCLOSED WITHOUT THE WRITTEN CONSENT OF ITW EAE

DR'N	JRS	SCALE	1:4
CK'D	GDY	DATE	04/16/2019
APP	GDY	SMALLER TO	---

COPYRIGHT ©2017 ITW EAE

**Despatch**

STAND ASSEMBLY PROCESS

D 404048 E 1 of 6

SIZE	CODE	PART NUMBER	REV	SHT OF SHITS

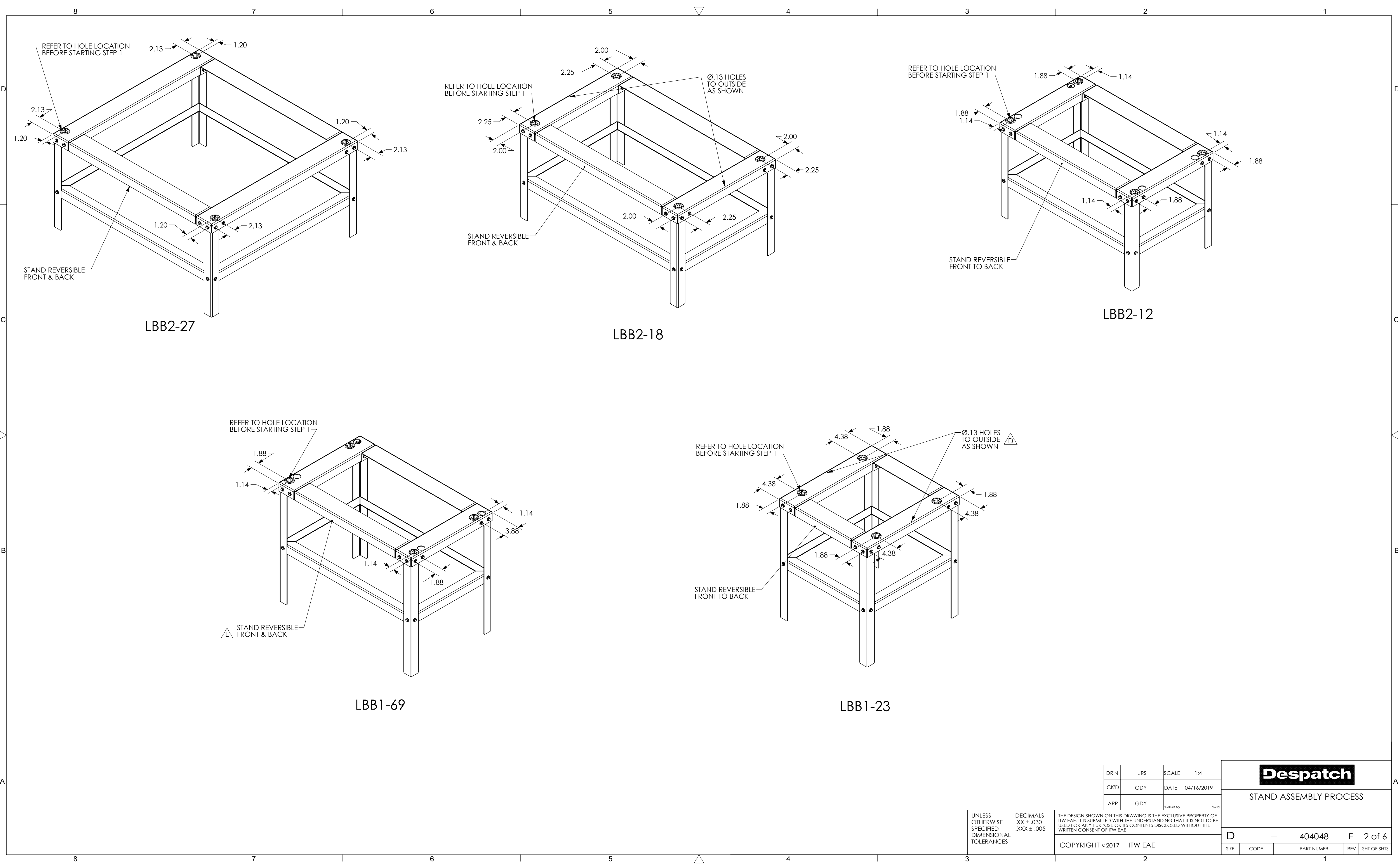

LBB2-27

LBB2-18

LBB2-12

LBB1-69

LBB1-23

DR'N	JRS	SCALE	1:4
CK'D	GDY	DATE	04/16/2019
APP	GDY	SMALLER TO	---

**Despatch**  
STAND ASSEMBLY PROCESS

UNLESS OTHERWISE SPECIFIED DIMENSIONAL TOLERANCES

DECIMALS  
.XX ± .030  
.XXX ± .005

THE DESIGN SHOWN ON THIS DRAWING IS THE EXCLUSIVE PROPERTY OF ITW EAE. IT IS SUBMITTED WITH THE UNDERSTANDING THAT IT IS NOT TO BE USED FOR ANY PURPOSE OR ITS CONTENTS DISCLOSED WITHOUT THE WRITTEN CONSENT OF ITW EAE

COPYRIGHT ©2017 ITW EAE

D	---	404048	E	2 of 6
SIZE	CODE	PART NUMBER	REV	SHT OF SHTS

8 7 6 5 4 3 2 1

NOTE: DENOTE ORIENTATION OF CHANNEL HOLE PER EACH MODEL LISTED ON SHEET 1 & 2

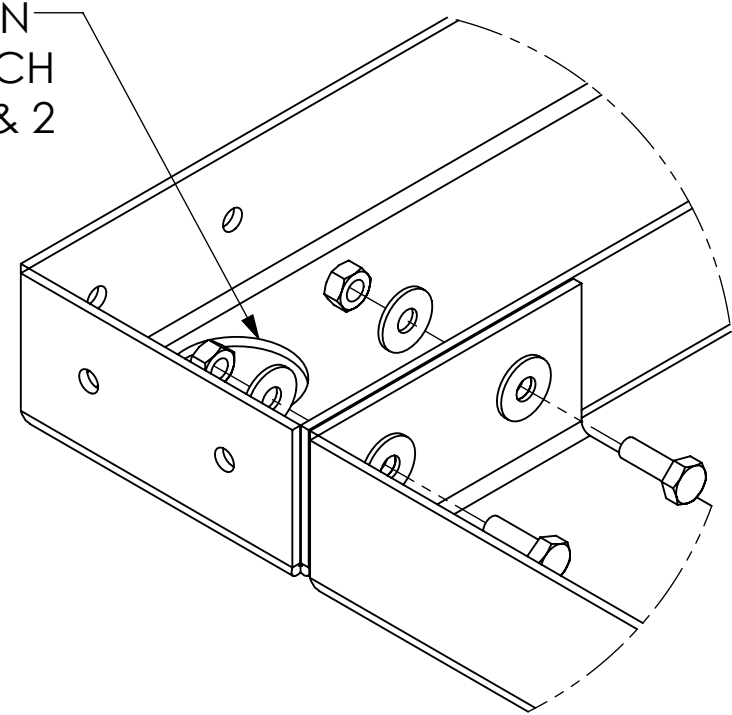

DETAIL A  
SCALE 1:2

REPEAT SEQUENCE IN ALL FOUR CORNERS

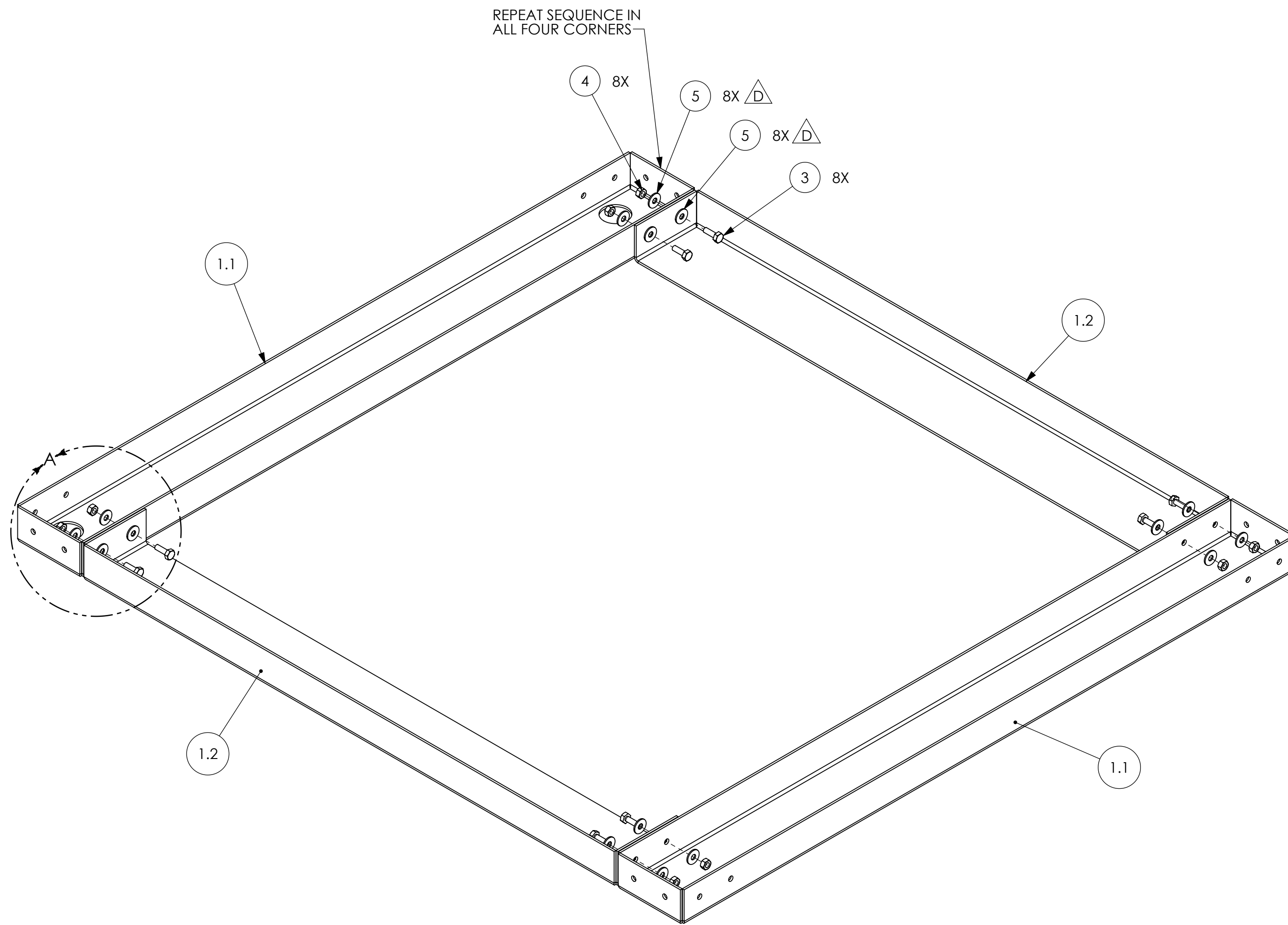

**STEP 1**

LAY ITEMS UPSIDE DOWN TO ASSEMBLE AS SHOWN  
-KEEP HARDWARE LOOSE

DR'N	JRS	SCALE	1:4
CK'D	GDY	DATE	04/16/2019
APP	GDY	SMALLER TO	---

**Despatch**

STAND ASSEMBLY PROCESS

UNLESS OTHERWISE SPECIFIED DIMENSIONAL TOLERANCES

DECIMALS  
.XX ± .030  
.XXX ± .005

THE DESIGN SHOWN ON THIS DRAWING IS THE EXCLUSIVE PROPERTY OF ITW EAE. IT IS SUBMITTED WITH THE UNDERSTANDING THAT IT IS NOT TO BE USED FOR ANY PURPOSE OR ITS CONTENTS DISCLOSED WITHOUT THE WRITTEN CONSENT OF ITW EAE

COPYRIGHT ©2017 ITW EAE

D	---	404048	E	3 of 6
SIZE	CODE	PART NUMBER	REV	SHT OF SHTS

8 7 6 5 4 3 2 1

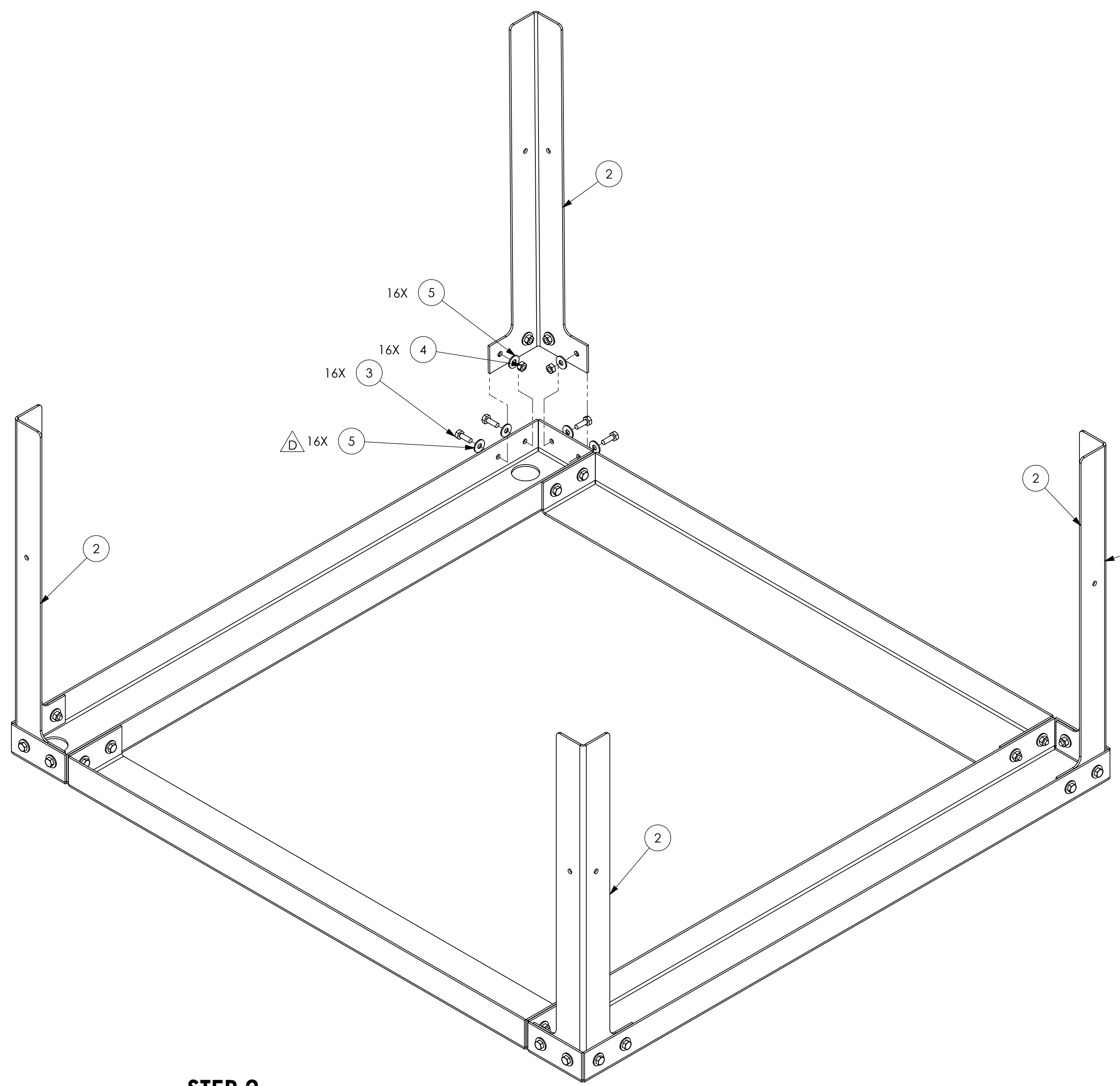

**STEP 2**  
 ASSEMBLE LEGS  
 - KEEP HARDWARE LOOSE  $\triangle$

REPEAT SEQUENCE IN ALL FOUR CORNERS

DR'N	JRS	SCALE	1:4
CK'D	GDY	DATE	04/16/2019
APP	GDY	SMALLER TO	---

**Despatch**  
 STAND ASSEMBLY PROCESS

UNLESS OTHERWISE SPECIFIED DIMENSIONAL TOLERANCES

DECIMALS  
 .XX ± .030  
 .XXX ± .005

THE DESIGN SHOWN ON THIS DRAWING IS THE EXCLUSIVE PROPERTY OF ITW EAE. IT IS SUBMITTED WITH THE UNDERSTANDING THAT IT IS NOT TO BE USED FOR ANY PURPOSE OR ITS CONTENTS DISCLOSED WITHOUT THE WRITTEN CONSENT OF ITW EAE

COPYRIGHT ©2017 ITW EAE

D	---	---	404048	E	4 of 6
SIZE	CODE	PART NUMBER	REV	SHT OF SHTS	

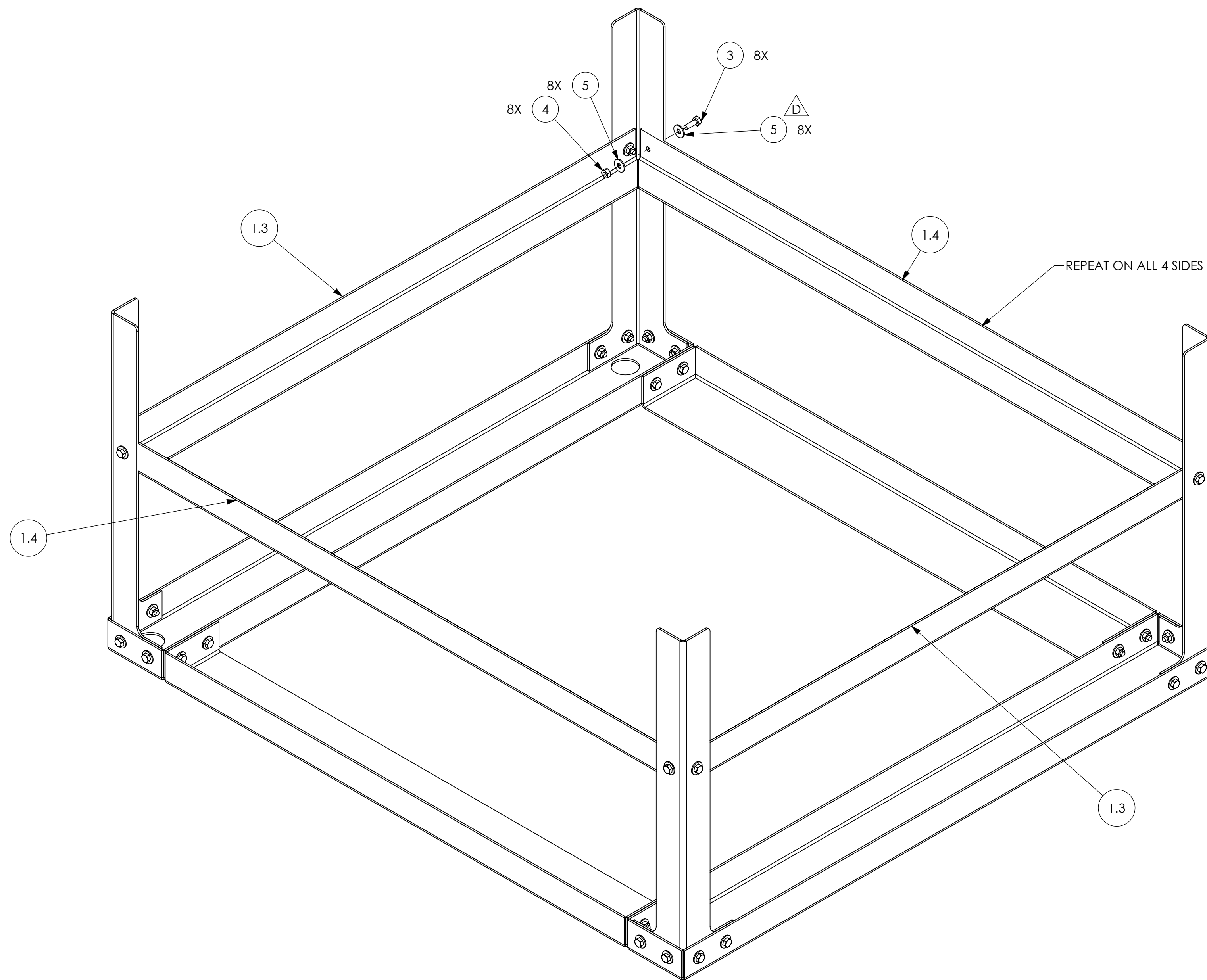

**STEP 3**  
 ASSEMBLE CROSS AND SIDE MEMBERS  
 -TIGHTEN ALL HARDWARE. SEE TORQUE NOTE 3.  $\triangle$   $\triangle$

DR'N	JRS	SCALE	1:4
CK'D	GDY	DATE	04/16/2019
APP	GDY	SMALLER TO	---

**Despatch**

STAND ASSEMBLY PROCESS

UNLESS OTHERWISE SPECIFIED DIMENSIONAL TOLERANCES

DECIMALS  
 .XX ± .030  
 .XXX ± .005

THE DESIGN SHOWN ON THIS DRAWING IS THE EXCLUSIVE PROPERTY OF ITW EAE. IT IS SUBMITTED WITH THE UNDERSTANDING THAT IT IS NOT TO BE USED FOR ANY PURPOSE OR ITS CONTENTS DISCLOSED WITHOUT THE WRITTEN CONSENT OF ITW EAE

COPYRIGHT ©2017 ITW EAE

D	---	404048	E	5 of 6
SIZE	CODE	PART NUMBER	REV	SHT OF SHTS

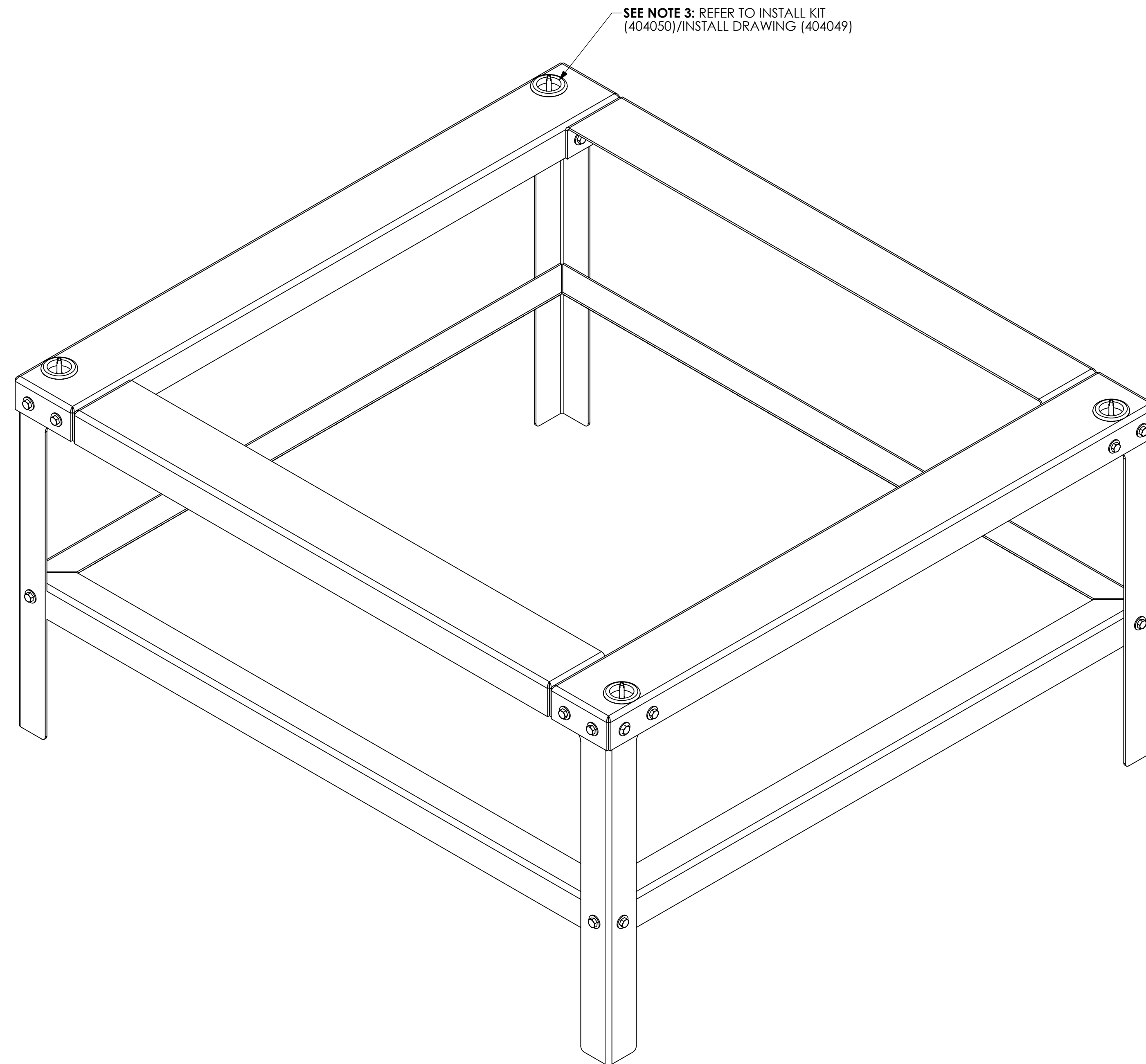

STEP 4  
INSTALL OVEN PER INSTALL KIT 

UNLESS OTHERWISE SPECIFIED DIMENSIONAL TOLERANCES

DECIMALS  
.XX ± .030  
.XXX ± .005

THE DESIGN SHOWN ON THIS DRAWING IS THE EXCLUSIVE PROPERTY OF ITW EAE. IT IS SUBMITTED WITH THE UNDERSTANDING THAT IT IS NOT TO BE USED FOR ANY PURPOSE OR ITS CONTENTS DISCLOSED WITHOUT THE WRITTEN CONSENT OF ITW EAE

COPYRIGHT ©2017 ITW EAE

DR'N	JRS	SCALE	1:4
CK'D	GDY	DATE	04/16/2019
APP	GDY	DATE	--

<b>Despatch</b>			
STAND ASSEMBLY PROCESS			
D	--	404048	E 6 of 6
SIZE	CODE	PART NUMBER	REV SHT OF SHTS