

TECHNICAL SUPPORT

ECO-17 Orbital All-Surface Floor Machine

Troubleshooting

Problem:	Possible Causes:	Solutions:
Plug on the power cord doesn't light up when plugged in.	Problem with the power cord.	Replace power cord. 38" Pigtail: Part # E575
	Burnt out light.	No action needed or replace power cord. 38" Pigtail: Part # E575
Plug lights up when plugged in but machine does not turn on.	Wires connecting to the switch may be loose or disconnected.	Open up the faceplate on the handle and check the switch for loose or disconnected wires. Re-connect any loose wires.
	Bad power switch.	Replace switch. Part # H167
	(120 volt units only) Motor circuit breaker may have tripped.	Make sure motor is first cooled down, then reset breaker by pressing button located on bottom of motor conduit box (see Figure A). Make sure that only the proper Mytee power cord extension is being used, and that it is good condition. If the problem persists or re-occurs, contact a Mytee Service Center.
Motor is drawing too many amps and blowing breakers.	Power cord is defective or damaged.	Replace power cord. 38" Pigtail: Part # E575
	Power switch has shorts or loose connections.	Replace power switch. Part # H167
	Power cord from the switch is defective or damaged.	Replace power cord. 38" Pigtail: Part # E575
Machine is making a loud grinding noise.	Bearing failure.	Replace bearing (click for instructions). Install Part # A140 Kit if using gravity feed (click for instructions).

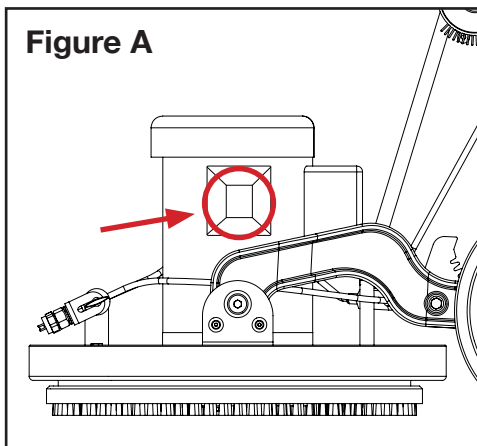

IMPORTANT: Make sure power to the motor is disconnected before servicing the motor. Failure to do this may result in serious injury or death.

ECO-17 Motor Internal Wiring

ECO MOTOR INTERNAL WIRING GUIDE

VIEW OF MOTOR FROM COOLING FAN END (TOP)

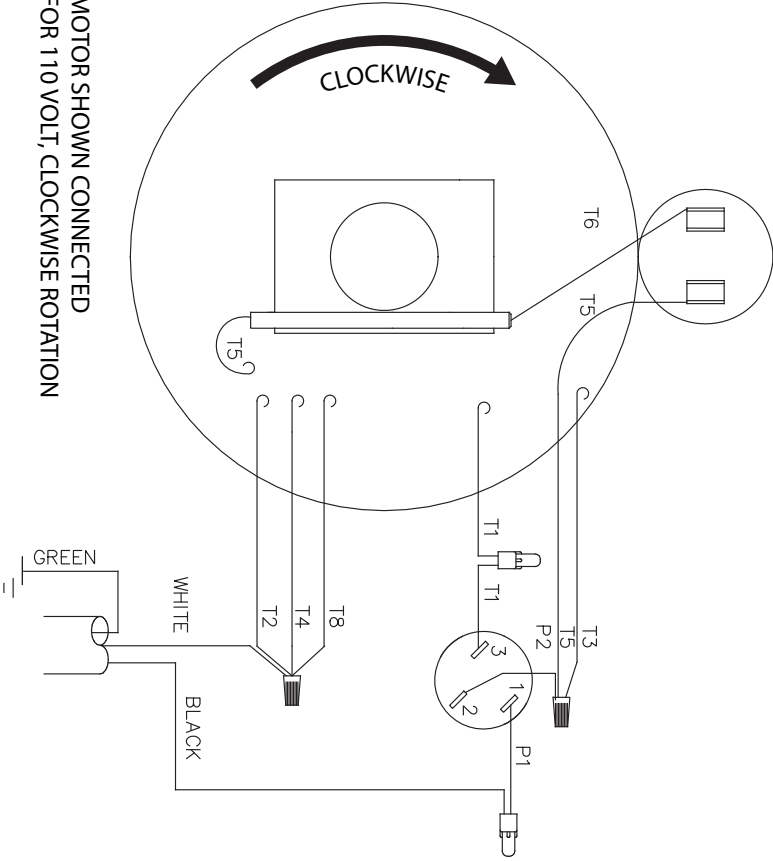

MOTOR SHOWN CONNECTED FOR 110 VOLT, CLOCKWISE ROTATION

NOTE: IN ORDER TO CREATE A CLOCKWISE PRECESSION OF THE PAD, THE MOTOR MUST BE DRIVEN COUNTER-CLOCKWISE.

LINE LEADS

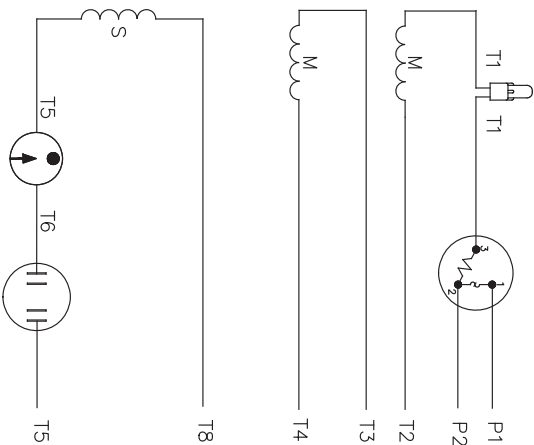

	ROTATION FACING LEAD END	L1	L2	JOIN	INSULATE SEPARATELY
220 VOLT	C.C.W.	P1	T4 T5	T2, T3 T8	P2
	C.W.	P1	T4 T8	T2, T3 T5	P2
110 VOLT	C.C.W.	P1	T2, T4 T8	P2, T3 T5	
	C.W.	P1	T2, T4 T8	P2, T3 T5	

KEYED SHAFT MOTORS THREADED SHAFT MOTORS