

1. INTRODUCTION

This document describes the operation of the SensorData / SensorNode devices, and how to interpret the data messages that are sent on the network. For examples and other support documentation, visit <https://support.digitalmatter.com>

The Sigfox and LoRaWAN device operation and protocols are very similar, and both handled in this document.

1.1. Revision History

| Date | Version | Changes |
|------------|---------|--|
| 2018-04-19 | 1.0 | Initial release |
| 2019-02-05 | 1.1 | Added data fields 50 & 51, UINT12 format, and downlinks |
| 2019-05-16 | 1.2 | Updated downlinks 41 & 42 |
| 2019-10-10 | 1.3 | Added version/reset message format |
| 2019-10-21 | 1.4 | Updated downlink 12, added downlinks 31-35 and 50 |
| 2019-10-28 | 1.5 | Added description of digital input pulse counts |
| 2020-05-01 | 1.6 | Added downlink 60 (Set Digital Output), updated data field 30 (Digital IO State) |
| 2021-01-20 | 1.7 | Added data fields 60 & 61 (MLX90614 & MB7040) |

1.2. Message Size Implications

We are limited to:

- **12-byte messages on the Sigfox network.**
- **11-byte (minimum) messages on the LoRaWAN network.**

The LoRaWAN maximum message size depends on the region and spreading factor (SF). 11 bytes is the worst case (EU868 region, SF12).

Because of these constraints, this data scheme aims to pack in data as efficiently as possible into the messages.

No date / time data is sent in the messages as the receiving software should use the date / time stamp from the network.

For the LoRaWAN devices, the LoRaWAN port is used as the first byte of the message; ie, **the port is the ID of the first data field in the message, and the data for that field starts at byte 0 of the payload.**

1.3. No Acknowledgement

In addition to the size limitation, the messages are not acknowledged by the network, so the data is sent on a "best effort" basis.

The implications of this are far-reaching as data cannot be guaranteed to have been delivered. The SensorData design therefore aims to send information that will not be adversely affected by missing messages. For example, for a tipping rain gauge the SensorData will record the count of the tips and send the total tip count each time, as opposed to trying to send a message for every tip, where if one was missed then the count on the server would be wrong.

1.4. Multi-part Data Avoided

As far as possible this data scheme avoids sending related data over more than one message due to the complexity of re-assembly on the server side and transmission limitations. Data fields are always contained within a single message.

More than one data field may appear in a single message.

In summary:

- One data field will not be split across multiple messages.
- Many data fields may appear in one message.

1.5. Number Formats

1.5.1. Little Endian

All data in the payloads is LITTLE ENDIAN. Be aware of this when converting data fields that consist of more than one byte from the data payload.

<https://en.wikipedia.org/wiki/Endianness#Little>

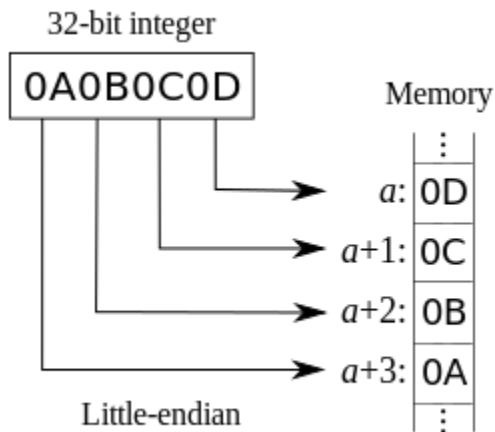

1.5.2. Signed (Negative) Numbers

Signed numbers are represented in "two's complement" form. Be aware of this when converting signed fields from the data payload.

https://en.wikipedia.org/wiki/Two's_complement

All multi-byte values are treated as little-endian.

1.5.3. Bit Numbering

Bit number is from the 'right' – the least significant bit (LSb) is b0.

2. DATA FIELDS

Each item of data that the SensorData measures and/or transmits is referred to as a "Data Field".

Each Data Field is identified by a Data Field ID value (also known as a "key"), and the software decoding the information needs to have knowledge of the IDs being sent to it and what their corresponding lengths are.

Note that in the case of LoRaWAN, the first ID is given by the LoRaWAN Port number for the message. The data starts at byte 0 of the payload.

2.1. List of Data Fields

| ID | Name | Size | Units |
|-----|---|------------|-------------------|
| 0 | Reserved | | |
| 1 | System Firmware version (reset message) | 4 | Struct |
| 2 | Debug Statistics | TBD | Struct |
| 3 | Reserved for Downlink Acknowledgement | | |
| | | | |
| 10 | GPS Position | 6 | Struct |
| | | | |
| 20 | Battery Voltage | 2 | UINT16 (mV) |
| 21 | Analog In 1 | 2 | UINT16 (mV) |
| 22 | Analog In 2 | 2 | UINT16 (mV) |
| 23 | Analog In 3 | 2 | UINT16 (mV) |
| | | | |
| 30 | Digital Input State | 1 | Bitfield |
| 31 | Input 1 Pulse Count | 2 | UINT16 |
| 32 | Input 2 Pulse Count | 2 | UINT16 |
| 33 | Input 3 Pulse Count | 2 | UINT16 |
| 39 | Digital Input Alert | 2 + 2*N | Struct |
| | | | |
| 40 | Internal Temperature | 2 | INT16 (x100 degC) |
| 41 | Digital Matter I2C Temperature Probe 1 (Red) | 2 | INT16 (x100 degC) |
| 42 | Digital Matter I2C Temperature Probe 2 (Blue) | 2 | INT16 (x100 degC) |
| 43 | Digital Matter I2C Temperature & Relative Humidity | 3 | Struct |
| | | | |
| 50 | Battery Energy Used Since Power Up. 65535 = Unknown | 2 | UINT16 (mAh) |
| 51 | Estimated Battery % Remaining. 255 = Unknown | 1 | BYTE (0.5%) |
| | | | |
| 60 | MLX6014 I2C Non-Contact Infrared Thermometer | 4 | Struct |
| 61 | MB7040 I2C Ultrasonic Distance Sensor | 2 | UINT16 (cm*) |
| | | | |
| 128 | SDI-12 Measurement 1 | N | Struct |
| 129 | SDI-12 Measurement 1 – Part 2 | N | Struct |
| 130 | SDI-12 Measurement 2 | N | Struct |
| 131 | SDI-12 Measurement 2 – Part 2 | N | Struct |
| 132 | SDI-12 Measurement 3 | N | Struct |
| 133 | SDI-12 Measurement 3 – Part 2 | N | Struct |
| 134 | SDI-12 Measurement 4 | N | Struct |

| | | | |
|------------|--|---|--------|
| 135 | SDI-12 Measurement 4 – Part 2 | N | Struct |
| 136 | SDI-12 Measurement 5 | N | Struct |
| 137 | SDI-12 Measurement 5 – Part 2 | N | Struct |
| | | | |
| 223 | Reserved | | |
| 224 to 255 | Reserved as the LoRaWAN specification reserves these ports | | |

*Output units may differ depending on specific model. Please see sensor datasheet for more info.

2.2. Hardware / Firmware Version (1)

Length = 4 bytes

Sent on device power on/reset

| Offset | Type | Name | Units |
|--------|------|------------------------|-------|
| 0 | BYTE | Product ID | |
| 1 | BYTE | Hardware Revision | |
| 2 | BYTE | Firmware Major Version | |
| 3 | BYTE | Firmware Minor Version | |

2.3. GPS Position (10)

Length = 6 bytes

All 0xFF == no fix available

| Offset | Type | Name | Units |
|--------|-------|-----------|-----------------------------|
| 0 | INT24 | Latitude | Deg x 10 ⁷ / 256 |
| 3 | INT24 | Longitude | Deg x 10 ⁷ / 256 |

INT24 for position gives 4m precision.

2.4. Digital IO State (30)

Contains a bitfield which correspond to the digital inputs and outputs. All unused/unsupported IOs will be set to 0.

| Offset | Type | Name | Units |
|---------|------|----------------------------------|-------|
| 0.0 | BOOL | Digital Input 1 state | |
| 0.1 | BOOL | Digital Input 2 State | |
| 0.2 | BOOL | Digital Input 3 State | |
| 0.3 | BOOL | 3V3 Out State (SensorNode v2.5+) | |
| 0.4-0.7 | - | Reserved | |

2.5. Digital Input Pulse Counts (31-33)

The digital input pulse counts are reported in fields 31 through 33, as unsigned 16-bit integers. They are *cumulative* counts, and will overflow periodically. Readings should be compared to their last reported value, and the difference (modulo 65536) used to increment a larger counter on your backend. Additionally:

- On the SensorData LoRaWAN, before firmware v2.2, and the SensorNode LoRaWAN before v2.4, the input counts would reset to zero when power was removed. There was no reliable way to detect this, as the reset message is sent for all resets, not just resets due to power removal.
- In the latest firmware versions, the input counts are monotonic and non-volatile, so you don't have to handle resets to zero.

2.6. Digital Input Alert (39)

Length = 2 + 2 x Number of digital *inputs* on device.

| Offset | Type | Name | Units |
|-----------|--------|--|------------------|
| 0 | BYTE | Current digital IO state | Bitfield |
| 1 | BYTE | Input that triggered the alert | Number |
| 2+(n-1)*2 | UINT16 | Digital input n cumulative pulse count | Number of pulses |

The pulse counts shows the same values as data fields 31-33.

2.7. Digital Matter I2C Temperature & Relative Humidity (43)

Length = 3

| Offset | Type | Name | Units |
|--------|-------|-------------------|-----------|
| 0 | INT16 | Temperature | x100 degC |
| 2 | UINT8 | Relative Humidity | 0.5% |

2.8. MLX6014 I2C Non-Contact Infrared Thermometer (61)

Length = 8

| Offset | Type | Name | Units |
|--------|--------|---|-------|
| 0 | INT16 | Raw Ta (Ambient Temperature). Average from multiple samples | * |
| 2 | UINT16 | Number of ambient samples taken | |
| 4 | INT16 | Raw Tobj (Object Temperature). Average from multiple samples | * |
| 6 | UINT16 | Number of object samples taken | |

*Output units dependant on device model. Please see sensor datasheet for more info.

2.9. SDI-12 Measurements

| Offset | Type | Name | Units |
|---------|-------|--|---|
| 0.0-0.3 | UINT4 | Number of data points | |
| 0.4-0.7 | UINT4 | Data type for this measurement 0 = soil moisture UINT8 1 = temperature UINT8 2 = INT16 (x100) 3 = INT32 (x1000) 4 = INT12 | The data type determines the data size, scale and offset to use (see below) |
| 1 | - | Data for the measurement Length depends on the data type and the number of data points | |

2.9.1. SDI-12 Soil Moisture UINT8

The SensorData packs SDI-12 soil moisture values into UINT8 fields to get as many values in the message as possible.

$SMP = (\text{value in field} / 2) - 5$, yielding a range of -5 to 122.5 with 0.5 precision.

Using this data type the maximum number of readings that can be packed into a single message is 10. A "Part 2" data field allows for a second set of 10 readings.

2.9.2. SDI-12 Temperature UINT8

The SensorData packs SDI-12 temperature values into UINT8 fields to get as many values in the message as possible.

$Temp = (\text{value in field} / 2) - 40$, yielding a range of -40 to 87.5 with 0.5 precision.

Using this data type the maximum number of readings that can be packed into a single message is 10.

2.9.3. SDI-12 Generic INT16 * 100

This allows an SDI-12 reading to be ± 327.67 with 2 decimal places. Using this data type, the maximum number of data points that can be packed into a single message is 5.

2.9.4. SDI-12 Generic INT32 * 1000

This allows an SDI-12 reading to be $\pm 2,147,483.647$ with 3 decimal places. Using this data type, the maximum number of data points that can be packed into a single message is 2.

2.9.5. SDI-12 Generic INT12

Designed to cover both soil moisture and temperature, INT12 covers -50 to +154.7, with a precision of 0.05.

$Value = (\text{value in field} / 20) - 50$

Using this data type, the maximum number of data points that can be packed into a single message is 6. Care must be taken when decoding values, as they span across multiple byte boundaries.

| Byte 1 | Byte 2 | | Byte 3 |
|--------------|--------------|--------------|--------------|
| Sample 1 MSB | Sample 1 LSB | Sample 2 MSB | Sample 2 LSB |

The length of the SDI-12 data can be determined by using the table below:

| | | | | | | |
|-------------------|---|---|---|---|---|---|
| Number of Samples | 1 | 2 | 3 | 4 | 5 | 6 |
| Length (bytes) | 2 | 3 | 5 | 6 | 8 | 9 |

Example: 3 samples returned – 25.60, 17.55, 12.30

Received: {0x5E, 0x85, 0x47, 0x4D, 0xE0} (5 bytes, last 4 bits can be ignored)

0x5E8 = 1512 -> 1512 / 20 - 50 = 25.60

0x547 = 1351 -> 1351 / 20 - 50 = 17.55

0x4DE = 1246 -> 1246 / 20 - 50 = 12.30

2.9.6. SDI-12 Error format

If the SensorData fails to take a reading from the specific sensor, the number of data points will be set to 0, and the type will be left as set. The total length will be 1 byte (no data section).

3. NON-VOLATILE COUNTER STORAGE

Where it makes sense the counter values will be written to non-volatile storage periodically (if they have changed). This is to allow them to be read if the device is reset or has its batteries changed.

4. MESSAGE PACKING

Data fields are packed into Sigfox/LoRaWAN messages as key/value pairs. The key is the ID of the data field and this is followed by the data.

The data field size is implied from the ID, or in some cases where the data is variable length then the length of the data field is encoded at the start of the data field itself.

This data layout allows us to fit as many of the data fields as we can into a limited byte size message in a flexible manner.

The SensorData firmware will determine the order and best way to pack the data fields into messages, possibly splitting the data fields across multiple messages. However, a single key/value will always be totally contained within a single message.

5. SCHEDULES

The SensorData is setup to transmit based on schedules.

Several different schedules can be setup (currently up to 5), and the schedule parameters contain information that allow the SensorData to determine the schedule timing.

Each schedule is defined to send messages that contain data from a selected list of data fields for the transmission schedule.

For example:

| | |
|------------|---|
| Schedule 1 | Every 30 minutes Transmit the temperature, humidity and tipping rain gauge count |
| Schedule 2 | Every 1 day |

| | |
|--|----------------------------------|
| | Transmit the GPS data (location) |
|--|----------------------------------|

5.1. Message Queueing

It is important to be aware of message restrictions in terms of duty cycle depending on the region that you are located in. Sigfox networks have a maximum of 140 messages per day per device.

If a schedule results in more than one message to be sent then the messages will be sent one after another, as duty cycle limitations allow.

5.2. Schedule Expiry

On the LoRaWAN devices, due to duty cycle limitations (depending on the region), a schedule data expiry has been added to guard against transmitting data that is too old. If the expiry time passes while waiting for a transmission, the schedule will be cancelled, and no more data will be sent.

If data is constantly being expired (only receiving the first payload of a schedule), the schedules should be changed to a more appropriate period for the region. For example, a schedule can be split into multiple schedules/periods.

6. PARAMETERS

6.1. Schedules

Each schedule is defined in a FlexiParam block. Currently the design caters for a time interval and an offset.

6.2. Data Fields

Certain data fields may need to have additional parameters set for them on an installation of a SensorData (eg. SDI-12 sensor data) and this is done by setting data field specific parameters on the SensorData.

6.2.1. SDI-12 Measurement Parameters

| Offset | Type | Name | Units |
|--------|-------|---|----------|
| 0 | CHAR | Address of the SDI-12 probe | '0'..'9' |
| 1 | CHAR | Measurement number | '0'..'9' |
| 2 | UINT8 | Number of data points | 1-15 |
| 3 | UINT8 | Data type for this measurement See 2.8 for more detail | |

7. DOWNLINK MESSAGES

Downlink payloads are limited to 8 bytes on Sigfox and can be as small as 11 bytes on LoRaWAN. Therefore we split downlink configuration messages up in to separate structures where each can configure a certain part of the device's functionality. The payload structure is determined by the payload ID; this is either the first byte in Sigfox payloads, or the port number in LoRaWAN payloads.

7.1. Acknowledgement Uplink

When a downlink message is received, the SensorData / SensorNode will send an explicit acknowledgement uplink (data field ID 3) on reception of a downlink. It sends this acknowledgement

only once, as soon as possible (limited by network, and after any already pending messages). The uplink includes a sequence number to help identify the specific downlink being acknowledged, despite any queuing / buffering in the network. 'Confirmed' and 'unconfirmed' downlinks are handled in the same way.

7.1.1. Sigfox Payload

| Offset | Description |
|---------|---|
| 0 | Field ID (3) |
| 1.0-1.6 | Sequence number (identifies downlink to server) |
| 1.7 | 0: Downlink rejected, 1: Downlink accepted |
| 2 | Firmware major version |
| 3 | Firmware minor version |

7.1.2. LoRaWAN Payload (Port 3)

| Offset | Description |
|---------|---|
| 0.0-0.6 | Sequence number (identifies downlink to server) |
| 0.7 | 0: Downlink rejected, 1: Downlink accepted |
| 1 | Firmware major version |
| 2 | Firmware minor version |

7.2. Downlink Message Formats

For LoRaWAN devices, the first byte (downlink type) is moved to the port number.

7.2.1. Downlink 1 - 5: Schedule Parameters

Sets parameters for schedules 1 to 5.

| Offset | Description |
|----------|--|
| 0 | Downlink type (1 - 5) |
| 1.0-1.6 | Downlink sequence number (reported in acknowledgement) |
| 1.7 | Reserved. Set to zero |
| 2 (BYTE) | Schedule period. 1-127: 1-127 minutes, 129-255: 1-127 Hours, 0 or 128 disables |
| 3 (BYTE) | Schedule Expiry time (10 seconds) |
| 4 (BYTE) | Item type 1 (See list of data fields) |
| 5 (BYTE) | Item type 2 |
| 6 (BYTE) | Item type 3 |
| 7 (BYTE) | Item type 4 |

7.2.2. Downlink 10: Analog Input Parameters

| Offset | Description |
|----------|--|
| 0 | Downlink type (10) |
| 1.0-1.6 | Downlink sequence number (reported in acknowledgement) |
| 1.7 | Reserved. Set to zero |
| 2.0 | Input 1: Enable 3.3V out on sample. Default 0 (disabled) |
| 2.1 | Input 1: Enable Vout on sample. Default 0 (disabled) |
| 2.2 | Input 2: Enable 3.3V out on sample. Default 0 (disabled) |
| 2.3 | Input 2: Enable Vout on sample. Default 0 (disabled) |
| 2.4 | Input 3: Enable 3.3V out on sample. Default 0 (disabled) |
| 2.5 | Input 3: Enable Vout on sample. Default 0 (disabled) |
| 2.6-2.7 | Reserved. Set to zero |
| 3 (BYTE) | Input 1: Power on delay (seconds). Default 0 |
| 4 (BYTE) | Input 2: Power on delay (seconds). Default 0 |
| 5 (BYTE) | Input 3: Power on delay (seconds). Default 0 |

Any parameters unsupported on the specific device should be set to 0.

7.2.3. Downlink 12: Digital Input Parameters

| Offset | Description |
|----------|--|
| 0 | Downlink type (12) |
| 1.0-1.6 | Downlink sequence number (reported in acknowledgement) |
| 1.7 | Reserved. Set to zero |
| 2 (BYTE) | Global maximum alarm rate. 1-127: 10-1270 seconds, 129-255: 10-1270 minutes, 0 or 128 disables. Default 600s (188) |
| 3.0 | Input 1: Transmit on low to high. Default off (0) |
| 3.1 | Input 1: Transmit on high to low. Default off (0) |
| 3.2 | Input 2: Transmit on low to high. Default off (0) |
| 3.3 | Input 2: Transmit on high to low. Default off (0) |
| 3.4 | Input 3: Transmit on low to high. Default off (0) |
| 3.5 | Input 3: Transmit on high to low. Default off (0) |
| 3.6 | Change the queue alarms settings** |
| 3.7 | Input 1: Queue alarms exceeding rate limit. Default off (0)** |
| 4 (BYTE) | Input 1: Debounce period (10 ms). Default 1s (100) |
| 5 (BYTE) | Input 2: Debounce period (10 ms). Default 1s (100) |
| 6 (BYTE) | Input 3: Debounce period (10 ms). Default 1s (100) |
| 7.0-7.1 | Input 1: Pull direction* |

| | |
|---------|---|
| 7.2-7.3 | Input 2: Pull direction* |
| 7.4-7.5 | Input 3: Pull direction* |
| 7.6 | Input 2: Queue alarms exceeding rate limit. Default off (0)** |
| 7.7 | Input 3: Queue alarms exceeding rate limit. Default off (0)** |

Any parameters unsupported on the specific device should be set to 0.

* For pull directions, 0 = no change to setting, 1 = no pull up/down, 2 = pull up, 3 = pull down. Available from v1.6 on the SensorNode LoRaWAN, v2.0 on the SensorData LoRaWAN, and v1.5 on the SensorData Sigfox.

** Defers transmission of alarms until the rate limit period has expired, instead of dropping them. No change is made to the setting unless bit 3.6 is set. Available from v2.4 on the SensorNode LoRaWAN, v2.2 on the SensorData LoRaWAN, and v1.7 on the SensorData Sigfox.

7.2.4. Downlink 14: GPS Parameters

| Offset | Description |
|----------|---|
| 0 | Downlink type (14) |
| 1.0-1.6 | Downlink sequence number (reported in acknowledgement) |
| 1.7 | Reserved. Set to zero |
| 2 (BYTE) | Required PDOP for valid GPS, 25-100: 2.5 to 10.0. Default 10.0 (100) |
| 3 (BYTE) | Required position accuracy for valid GPS, 5-100: 5-100 m. Default 75 m |
| 4 (BYTE) | Required speed accuracy for valid GPS, 0.1 km/h, 2.9-19.8 km/h. Default 10 km/h (100) |
| 5 (BYTE) | Discard first N GPS points to allow solution to settle, 0-32: 0-32 positions. Default 3 |
| 6 (BYTE) | Fix timeout (seconds). Default 90 |

7.2.5. Downlink 16: SDI-12 General Parameters

| Offset | Description |
|----------|--|
| 0 | Downlink type (16) |
| 1.0-1.6 | Downlink sequence number (reported in acknowledgement) |
| 1.7 | Reserved. Set to zero |
| 2 (BYTE) | Global power up delay (seconds). Default 5 |

7.2.6. Downlink 17 - 21: SDI-12 Measurement Parameters

Downlink type 17 = measurement 1, downlink type 18 = measurement 2 etc.

| Offset | Description |
|--------|-----------------------|
| 0 | Downlink type (17-21) |

| | |
|----------|---|
| 1.0-1.6 | Downlink sequence number (reported in acknowledgement) |
| 1.7 | Reserved. Set to zero |
| 2 (BYTE) | Measurement address (0-9) |
| 3 (BYTE) | Measurement type (see SDI-12 protocol specifications) |
| 4 (BYTE) | Measurement count (0-20). See SDI-12 measurements for limitations |
| 5 (BYTE) | Measurement data type (see SDI-12 measurements) |

7.2.7. Downlink 30: Power Parameters

| Offset | Description |
|---------|---|
| 0 | Downlink type (30) |
| 1.0-1.6 | Downlink sequence number (reported in acknowledgement) |
| 1.7 | Enable Vout Boost. Default off (0) |
| 2.0-2.1 | 0 = Disable battery level sensing, 1 = mAh sensing only, 2 = mAh & % sensing, 3 = reserved. |
| 2.2-2.7 | Reserved. Set to zero |

7.2.8. Downlink 31 - 35: Schedule Power Parameters

Sets parameters for schedules 1 to 5.

| Offset | Description |
|----------|---|
| 0 | Downlink type (31 - 35) |
| 1.0-1.6 | Downlink sequence number (reported in acknowledgement) |
| 1.7 | Reserved. Set to zero |
| 2.0 | Enable 3.3V out for the entire schedule. Default 0 (disabled) |
| 2.1 | Enable Vout for the entire schedule. Default 0 (disabled) |
| 2.2-2.7 | Reserved. Set to zero |
| 3 (BYTE) | Power on delay (seconds). Default 0 |

Available from v2.4 on the SensorNode LoRaWAN, v2.2 on the SensorData LoRaWAN, and v1.7 on the SensorData Sigfox.

7.2.9. Downlink 40: LoRaWAN Channels

Only applies to LoRaWAN devices. Port 40.

| Offset | Description |
|---------|---|
| 0.0-0.6 | Downlink sequence number (reported in acknowledgement) |
| 0.7 | Reserved. Set to zero |
| 1.0-1.3 | Minimum data rate to use when ADR is disabled. Default is 0 (DR0) |

| | |
|---------|---|
| 1.4-1.7 | Maximum data rate to use when ADR is disabled. Default is 2 (DR2) |
| 2-10 | Uplink channel mask, set bits are enabled channels, LSB of the 1st byte is channel 0, MSb of the 9th byte is channel 71, set all zeros (default) for the region-specific defaults |

The SensorData / SensorNode will spread its transmissions out over the allowed data rates in such a way as to equalize the time spent on-air at each data rate. For the default setting of DR0-DR2, this gives a 16 / 30 / 54% split between the three data rates, and maximizes the gateway's capacity. However, the relative range of the three data rates are 100, 75, and 50% respectively. When ADR is enabled, the network server controls the data rate instead.

The uplink channel mask should be left 0 (default) in regions where the network join channels are fixed: EU863-870, IN865-867, AS923, and KR920-923. In these regions, the gateway will tell the device which channels to use, during the join procedure.

In regions where the join channels are not specified (US902-928, AU915-928), you should set the channel mask to avoid continued transmission on unused channels. In these regions the gateway will usually not tell the device which channels to use, resulting in significant packet loss if the mask hasn't been programmed.

7.2.10. Downlink 41: LoRaWAN Application

Only applies to LoRaWAN devices. Port 41.

| Offset | Description |
|---------|--|
| 0.0-0.6 | Downlink sequence number (reported in acknowledgement) |
| 0.7 | Set JoinEUI. 0 = Use default JoinEUI, 1 = Use supplied JoinEUI. Default 0 |
| 1-8 | JoinEUI, big endian , ie. JoinEUI 70-B3-D5-70-50-00-00-05 is encoded with first byte as 0x70 and the second byte 0xB3, where 70-B3-D5-70-5 is the manufacturer identifying portion of the JoinEUI |

The acknowledgement will be transmitted **once** on the existing JoinEUI, and then the device will switch to the new JoinEUI. It continues to use the already provisioned NwkKey and AppKey, which cannot be programmed over the air.

Note that:

- In LoRaWAN 1.0, the JoinEUI is known as the AppEUI
- In LoRaWAN 1.1, changing the JoinEUI resets three cryptographic counters:
 - RJCount1
 - DevNonce
 - JoinNonce
- So after changing the JoinEUI in 1.1, you must reset the counters on the join server

7.2.11. Downlink 42: Advanced LoRaWAN Options

Only applies to LoRaWAN devices. Port 42.

| Offset | Description |
|----------|--|
| 0.0-0.6 | Downlink sequence number (reported in acknowledgement) |
| 0.7 | Reserved. Set to zero |
| 1 (BYTE) | Days between network joins, 0 disables. Default 14 |

| | |
|----------|---|
| 2.0-2.1 | ADR support. 0 = never, 2 = Always. Other options are reserved. Default never. |
| 2.2-2.3 | Reserved. Set to zero |
| 2.4-2.7 | Initial frame repetitions (NbTrans/Reps), 1-15. Default 1. |
| 3.0-3.3 | Initial MaxCount0, sets uplinks between Rejoin0 attempts in LoRaWAN 1.1 OTAA. Uplink interval equals $2^{(4+MaxCount0)}$. Default 15. |
| 3.4-3.7 | Initial MaxTime0, sets approx. time between Rejoin0 attempts in LoRaWAN 1.1 OTAA. Uplink period equals $2^{(10+MaxTime0)}$ s. Default 15. |
| 4.0-4.3 | Initial ADRAckLimitExp, sets uplinks between ADR confirmation requests. Uplink interval equals $2^{ADRAckLimitExp}$. Default 6 (limit is 64) |
| 4.4-4.7 | Initial ADRAckDelayExp, sets uplinks between ADR backoff steps. Uplink interval equals $2^{ADRAckDelayExp}$. Default 5 (delay is 32) |
| 5 (INT8) | Maximum Tx power limit, signed. -128-127: -128 to 127 dBm EIRP. Default 127 (no limit) |
| 6 (BYTE) | Random Tx delay. 0: disabled, 1-127: 1-127 seconds, 129-255: 1-127 minutes. Default disabled. |

By default, the SensorData / SensorNode rejoins the network once a fortnight, in case the network server has somehow forgotten the session keys. This period can be extended to up to 255 days, or disabled entirely. However, if a device is accidentally deleted on the network server, or the network server suffers a database failure and loses the session keys, the server will be unable to decrypt any device data until it has rejoined. Rejoining fortnightly generates several extra transmissions, but lowers the time spent out of service in the event of an accident.

By default, the device does not request Adaptive Data Rate (ADR) when sending uplinks, choosing instead to control its data rate according to the configured range. However, you may wish to enable ADR when the device is mostly stationary, to optimize power usage and network capacity.

Fields from offset 2.4 onwards are supported from firmware version 2.0.

7.2.12. Downlink 50: MLX90614 Parameters

| Offset | Description |
|----------|---|
| 0 | Downlink type (50) |
| 1.0-1.6 | Downlink sequence number (reported in acknowledgement) |
| 1.7 | Reserved. Set to zero |
| 2 (BYTE) | Independent sample period, 1-255: 1-255 minutes, 0: disabled (samples taken when schedule runs). Default 0 (disabled) |
| 3 (BYTE) | Power on delay, 0-15: 0-15 seconds. Default 1 |
| 4 (BYTE) | Number of samples to average, 1-255. Default 1 |

Available from v2.4 on the SensorNode LoRaWAN, v2.2 on the SensorData LoRaWAN. Not yet available on the SensorData Sigfox.

7.2.13. Downlink 60: Set Digital Output

| Offset | Description |
|--------|-------------|
|--------|-------------|

| | |
|---------|--|
| 0 | Downlink type (60) |
| 1.0-1.6 | Downlink sequence number (reported in acknowledgement) |
| 1.7 | Reserved |
| 2.0-2.1 | 3V3 Output, 0: No change, 1: Toggle, 2: Clear, 3: Set |
| 2.2-2.7 | Reserved |
| 3.0-5.7 | Duration, 0: Indefinitely, 1-16777215: 1-1677215 seconds (~6 months) |

Available from v2.5 on the SensorNode LoRaWAN only. Note that:

- The effect lasts for the specified duration, or until loss of power.
- The digital output will glitch low if the device must reboot in response to a parameter configuration downlink.
- Message queuing at the network layer can cause downlinks to be delivered late, or multiple times, and packet loss can cause the acknowledge uplink to be lost.
- Each time a downlink is received by the device it will replace any existing commands for all outputs not marked 'No change', irrespective of the downlink sequence number.
- Leaving the 3V3 output on for extended periods will reduce battery life.

8. CONTACT INFORMATION

View our website and online knowledge base for the latest documentation and FAQs:

<http://www.digitalmatter.com/support>

Contact: <http://www.digitalmatter.com/contact>

Sign up for our product news and updates: <http://eepurl.com/buyjvb>