

2025 | Forester

+ 2024 Forester Wilderness



The Subaru Forester. Love begins with trust.





Foot-activated Hands-Free Power Rear Gate^{2,3}

Go far, feel
at home.

Versatile

The Forester is designed with room to spare—lots of it. So, bring along your nice-to-haves because the Forester is equipped with 74.4 cubic feet of cargo space¹ and an extra-wide rear gate opening. When your hands are full, there's an available foot-activated Hands-Free Power Rear Gate^{2,3} that makes for smooth loading. Plus, adjusting your cargo space is simple with 60/40-split flat-folding rear seats that collapse with the press of a button, and low-profile roof rails allow you to throw bigger gear up top. Even when you're all packed up, your passengers can stretch out and relax in the 110.8¹ cubic feet of passenger space filled with soft-touch materials and enough elbow, leg and head room for everyone.

Capable

Blue skies might not be in the forecast. And smooth, dry pavement may be scarce. But the Forester has you covered. You'll feel the confidence to venture farther with 8.7 inches of ground clearance⁴ and available dual-function X-MODE,² which has specific settings to take on snow and dirt or deep snow and mud. Since it's a Subaru, the Forester comes equipped with a powerful SUBARU BOXER engine and standard Subaru Symmetrical All-Wheel Drive for tried-and-true reliability on every type of journey.

1 Without available power moonroof. 2 Availability varies by trim level. See your Subaru retailer for details. 3 Foot activation function not operable when equipped with accessory tow hitch. See your Subaru retailer for details. 4 9.2 inches of ground clearance for 2024 Forester Wilderness only.



Dual-function X-MODE²



Ample cargo space¹



Spacious cabin



Raised roof rails²



SUBARU STARLINK[®] 11.6-inch Multimedia Navigation System²



An extra set of eyes every time you drive.

Every Forester includes standard Subaru EyeSight Driver Assist Technology,¹ now with a wide-angle mono camera for enhanced pedestrian and cyclist detection. Equipped with a comprehensive suite of innovative safety features, like available Automatic Emergency Steering,² EyeSight looks ahead, alerts you to potential dangers and can even intervene to help you avoid a collision.



Forester Limited in Horizon Blue Pearl.



Automatic Emergency Steering²

Can help you avoid a collision by providing automatic steering and pre-collision braking support if it determines there's enough space to intervene.



Pre-Collision Braking

Can help slow and bring your Forester to a full stop if necessary.



Advanced Adaptive Cruise Control with Lane Centering

Automatically helps keep you centered in your lane, at a safe distance behind the car in front of you—even in traffic and around curves.



Pre-Collision Throttle Management

Can reduce engine power to help give you more time to react and to help minimize possible impact force in case of a collision.



Lane Departure and Sway Warning with Lane Departure Prevention

If you accidentally begin to drift to the edge of your lane, EyeSight can alert you with visible and audible warnings before you cross over the lane markers. And when activated, Lane Departure Prevention can even help steer you back into your lane.

¹ EyeSight is a driver assist technology, which may not operate optimally under all driving conditions. The driver is always responsible for safe and attentive driving. System effectiveness depends on many factors such as vehicle maintenance, weather and road conditions. See your Owner's Manual for complete details on system operations and limitations. ² Automatic Emergency Steering requires Blind-Spot Detection. Availability varies by trim level. See your Subaru retailer for details.

Safe and sound all around.

Equipped with the latest safety technology and built on the strength of the Subaru Global Platform, the 2025 Forester is engineered for your peace of mind. You can opt for the all-new 360-degree Surround-View Monitor¹ to give you enhanced visibility in tight trails or parking spots. Blind-Spot Detection,^{1,2} Rear Cross-Traffic Alert^{1,2} and Reverse Automatic Braking^{1,3} each work to provide reassurance in all directions.

Forester Limited in Crimson Red Pearl with optional equipment.



Blind-Spot Detection

Using radar sensors, Blind-Spot Detection^{1,2} warns you with a visual indicator on your exterior mirror if the system detects a vehicle in your blind spot. Another feature of this system, Lane Change Assist, alerts you with a flashing indicator on your exterior mirror if it senses a vehicle approaching at a higher speed in a neighboring lane.



Rear Cross-Traffic Alert

Rear Cross-Traffic Alert^{1,2} uses radar sensors to help warn you of traffic approaching from the side as you are backing up, utilizing a flashing visual indicator on your exterior mirror and Rear-Vision Camera display as well as an audible warning.

¹ Availability varies by trim level. See your Subaru retailer for details. ² Blind-Spot Detection, Lane Change Assist and Rear Cross-Traffic Alert are systems designed to assist the driver by monitoring the rear and side areas of the vehicle during a lane change or reversing and are not a substitute for safe and attentive driving. ³ The Reverse Automatic Braking System is not a substitute for safe and attentive driving. System effectiveness depends on many factors, such as vehicle maintenance, weather and road conditions. Always exercise caution and use vehicle mirrors and the Rear-Vision Camera when backing up. See your Owner's Manual for complete details on system operation and limitations. ⁴ Centers for Disease Control and Prevention, citing National Center for Statistics and Analysis. Distracted Driving: 2016, in Traffic Safety Research Notes. DOT HS 812 517. April 2018, National Highway Traffic Safety Administration: Washington, D.C. ⁵ The DriverFocus Distraction Mitigation System is a driver recognition technology



 **DriverFocus**[®]
Distraction Mitigation System

Every day in the U.S., more than 1,000 people are injured in crashes reported to have involved a distracted driver.⁴ As an industry leader in safety, Subaru developed the DriverFocus Distraction Mitigation System,^{1,5} one of the first technologies of its kind. Engineered for both new and experienced drivers, it works together with EyeSight to help detect distracted or drowsy driving. If the driver's attention strays from the road for too long, DriverFocus can deliver visual and auditory alerts to bring attention back to the road.



Reverse Automatic Braking

Reverse Automatic Braking^{1,3} can detect objects directly behind your vehicle when backing up at a low speed and can help bring the Forester to a stop should an object be detected within its range and the brakes have yet to be applied. There's also the Rear-Vision Camera to help you keep an eye out.



SUBARU STARLINK[®] Safety and Security

The Forester features the latest SUBARU STARLINK Safety and Security^{1,6} system, which can alert a first responder in an emergency, help police locate your vehicle if it's stolen and more. And to get you started, new Forester drivers enjoy a free three-year STARLINK[®] Safety Plus trial, which includes Advanced Automatic Collision Notification, Enhanced Roadside Assistance, SOS Emergency Assistance and more.

designed to alert drivers if their attention to the road wavers or if the driver's face appears to turn away. The driver is always responsible for safe and attentive driving. System effectiveness may be affected by articles of clothing worn on the head or face. See your Owner's Manual for complete details on system operation and limitations. ⁶ Activation with subscription required. Includes a 3-year trial subscription to STARLINK Safety Plus services and a 6-month trial subscription to STARLINK Safety and Security Plus services. The Concierge plan can be purchased annually or monthly. A credit card on file will be required for specific packages and for renewal purposes. Not available in all states. See your Subaru retailer for details.

Designed to connect.

Inside the 2025 Forester, you'll find all the latest tech features—each intuitive and easy to use. Before you step in, you can start your engine from your phone and get your cabin to the perfect temperature with Remote Engine Start with Climate Control.^{1,2} Then, SUBARU STARLINK® Multimedia makes connecting to your music, navigation and apps seamless with available wireless Apple CarPlay® and Android Auto™ integration.¹ Everything you need will be easily accessible on the large 11.6-inch touchscreen,¹ and to keep your phone charged, you'll even have the option of a Qi® wireless charging pad.^{1,3} Plus, with available STARLINK Concierge Services, you can make reservations or buy tickets on the go.^{1,4}

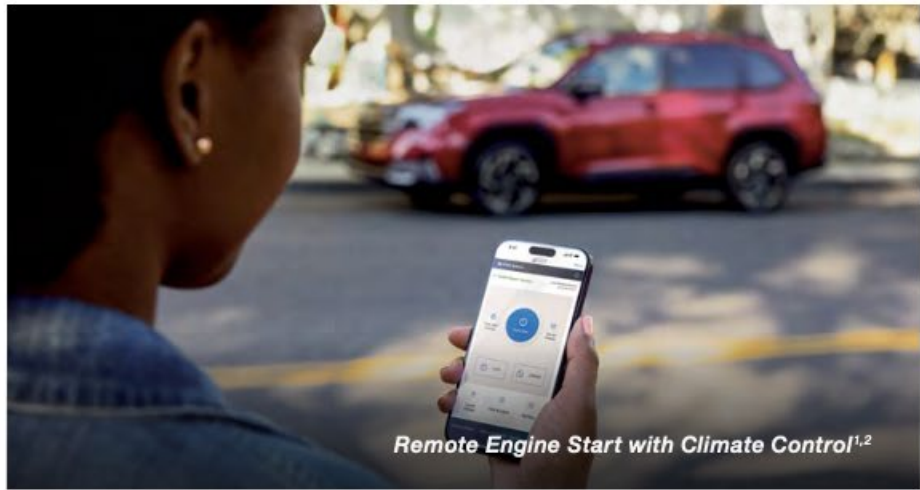

Remote Engine Start with Climate Control^{1,2}



Panoramic moonroof¹



Dual rear-seat USB charge ports¹



Harman Kardon® premium audio system¹

High tech,
low maintenance.



11.6-inch touchscreen¹

Whether it's a long road trip or a quick run to the grocery store, the all-new Forester is designed to keep you comfortable when you're on the go. You're greeted with high-quality soft-touch materials throughout the spacious cabin. Too hot or cold? Once you're inside, available heated and ventilated seats¹ and a heated steering wheel¹ will get you back to your ideal temperature. The second row offers the comforts of available heated outboard seats¹ and rear AC vents,¹ plus USB-A and USB-C¹ ports for on-the-go charging. Above, an available panoramic moonroof¹ lets in natural light and gives the cabin a wide-open, airy feel. To hear your music and podcasts as they were intended, you can opt for a Harman Kardon[®] premium audio system.¹

1 Availability varies by trim level. See your Subaru retailer for details. 2 Requires Keyless Access with Push-Button Start and subscription to STARLINK Safety and Security Plus services. 6-month free trial included. Not available in all states. See your Subaru retailer for details. 3 Qi[®] wireless charging may not be compatible with all mobile devices. When using the wireless charging system, avoid placing metal objects between the wireless charger and the mobile device when charging is active. Doing so may cause metal objects to become hot and could cause burns. 4 Activation with subscription required. Includes a 3-year trial subscription to STARLINK Safety Plus services and a 6-month trial subscription to STARLINK Safety and Security Plus services. The Concierge plan can be purchased annually or monthly. A credit card on file will be required for specific packages and for renewal purposes. Not available in all states. See your Subaru retailer for details.

The unpaved world is officially open.

The 2024 Forester Wilderness

Nothing sounds too remote when you're in the 2024 Forester Wilderness. With dual-function X-MODE, 9.2 inches of ground clearance and gearing that's engineered to optimize climbing performance, this Forester is designed to meet the demands of the terrain. Inside and out, you'll find function and purpose, from its StarTex[®] water-repellent upholstery to 17-inch wheels with all-terrain tires. Plus, we've increased its approach, departure and breakover angles. The 2024 Forester Wilderness has wider roof rails with a greater static roof load capacity, and it can tow up to 3,000 pounds,¹ so you can bring all the gear you need for that unpaved adventure.

¹ Trailer brakes may be needed. Some safety features, including X-MODE, Blind-Spot Detection and Rear Cross-Traffic Alert, may not function properly when towing. See your Subaru retailer for details.



2024 Forester Wilderness with Gray Textured StarTex and optional equipment



Dual-function X-MODE



11 | 2025 Forester

2024 Forester Wilderness in Geyser Blue with optional equipment.



Roof rails with increased static load-carrying capacity and Anodized Copper-finish tie-down points



All-weather floor mats

2025 Forester | Trim Levels



Forester

- 180-hp 2.5-liter 4-cylinder SUBARU BOXER engine with direct injection and auto start-stop technology
- Subaru Symmetrical All-Wheel Drive with Active Torque Vectoring
- Lineartronic® CVT (Continuously Variable Transmission)
- 1,500-lb. towing capacity¹
- SI-DRIVE® Engine Performance Management
- 17-inch aluminum-alloy wheels. Dark Metallic with machine finish.
- Raised roof rails
- Front, rear and side underguards with black accents
- Auto-on/off LED Steering Responsive Headlights with High Beam Assist
- Daytime Running Lights (DRL)
- Cloth upholstery
- 6-way manually adjustable driver seat and 4-way manually adjustable front-passenger seat
- SUBARU STARLINK® Dual 7.0-inch Multimedia with Apple CarPlay® and Android Auto™ integration, SiriusXM² including 4-month trial subscription and SiriusXM Travel Link^{®2} trial subscription, USB-A input port and Bluetooth®
- EyeSight Driver Assist Technology³: Pre-Collision Braking System, Pre-Collision Throttle Management, Lane Departure and Sway Warning with Lane Departure Prevention, and Advanced Adaptive Cruise Control with Lane Centering
- Dual-zone automatic climate control system
- LED rear gate light
- Cargo-area headliner hooks
- Driver auto-up/down power window
- LED cargo-area light
- Rear-Vision Camera
- 60/40-split flat-folding rear seatback
- Rear Seat Reminder
- 8 airbags (SRS)⁴: dual-stage deployment driver and front-passenger, driver's knee, front-passenger seat cushion, front and rear outboard occupant side curtain with rollover sensor, and seat-mounted front side impact
- Whiplash-reducing front seats with height-adjustable head restraints
- Pretensioner and force limiter equipped height-adjustable 3-point front seatbelts and 3-point seatbelts for all rear seating positions
- LATCH system: Lower Anchors and Tethers for Children



Forester Premium

Includes Forester key features and adds:

- X-MODE with Hill Descent Control
- LED fog lights
- Panoramic moonroof
- Dark gray-finish exterior mirrors
- Privacy glass
- Premium cloth upholstery
- Keyless Access with Push-Button Start
- 10-way power-adjustable driver seat with 2-way lumbar support
- SUBARU STARLINK 11.6-inch Multimedia Plus with wireless Apple CarPlay® and Android Auto™ integration, SiriusXM² with 360L including 4-month trial subscription and SiriusXM Travel Link^{®2} trial, USB-A and USB-C input ports, and Bluetooth®
- Leather-wrapped steering wheel
- Center console rear vents
- 6 speakers
- 4G LTE Wi-Fi capability⁵
- Qi® wireless smartphone charging pad⁶
- Rear center console illuminated dual USB-A and USB-C input ports
- All-Weather Package: Heated exterior mirrors, 3-mode heated front seats, windshield wiper de-icer
- Driver and front-passenger auto-up/down power windows
- Reclining rear seatback
- Rear center armrest with dual cup holders
- Cargo-area cover
- STARLINK Safety and Security enabled²¹: Includes features and services such as Advanced Automatic Collision Notification, SOS Emergency Assistance, Enhanced Roadside Assistance, Maintenance Notifications, Vehicle Health Reports, Diagnostic Alerts, Remote Engine Start with Climate Control, Remote Lock/Unlock, Concierge Services and more

Optional Package

Option Package (OP 15): • Blind-Spot Detection with Lane Change Assist and Rear Cross-Traffic Alert⁷ • EyeSight Driver Assist Technology³ with Automatic Emergency Steering⁸ • Hands-Free Power Rear Gate⁹



Forester Sport

Includes Forester Premium key features and adds:

- Dual-function X-MODE with Hill Descent Control
- Steering wheel paddle-shift control switches
- 19-inch aluminum-alloy wheels with Bronze finish
- Low-profile roof rails
- Front, rear and side underguards with bronze accents
- Crystal Black Silica exterior mirrors with integrated turn signals
- Bronze and Crystal Black Silica exterior accents
- Stainless steel tailpipe tip
- Gray Sport StarTex upholstery
- Brown stitching and bronze interior trim accents
- Blind-Spot Detection with Lane Change Assist and Rear Cross-Traffic Alert⁷
- EyeSight Driver Assist Technology³ with Automatic Emergency Steering⁸

Optional Package

Option Package (OP 24): • SI-DRIVE with Sport Sharp (S#) mode • Harman Kardon® 576-watt-equivalent premium audio system with 11 speakers • Hands-Free Power Rear Gate⁹ • Reverse Automatic Braking¹⁰

2024 Forester Wilderness



Forester Limited

Includes Forester Premium key features and adds:

- Dual-function X-MODE with Hill Descent Control
- Steering wheel paddle-shift control switches
- 18-inch aluminum-alloy wheels. Dark Metallic with machine finish.
- Dark gray-finish exterior mirrors with integrated turn signals
- Front, rear and side underguards with dark gray inserts
- Hands-Free Power Rear Gate⁹
- Stainless steel tailpipe tip
- Leather-trimmed upholstery
- Heated steering wheel
- 8-way power-adjustable front-passenger seat
- One-touch folding rear seatback
- Blind-Spot Detection with Lane Change Assist and Rear Cross-Traffic Alert⁷
- EyeSight Driver Assist Technology³ with Automatic Emergency Steering⁸

Optional Package

Option Package (OP 42): • SUBARU STARLINK 11.6-inch Multimedia Navigation System with 3 years of free map updates and SiriusXM Travel Link^{®11} trial, and Subaru Live Traffic including 1-year trial subscription¹² • Harman Kardon[®] 576-watt-equivalent premium audio system with 11 speakers • Reverse Automatic Braking¹⁰



Forester Touring

Includes Forester Limited key features and adds:

- 19-inch aluminum-alloy wheels. Dark Gray with machine finish.
- Low-profile roof rails
- Front, rear and side underguards with gloss black inserts
- Crystal Black Silica finish exterior mirrors with integrated turn signals and automatic reverse tilt
- Available Touring Brown Leather with Ultrasuede[®] inserts
- 2-position driver seat memory and exterior mirrors
- Heated and ventilated front seats
- Heated outboard rear seats
- SUBARU STARLINK 11.6-inch Multimedia Navigation System with 3 years of free map updates, wireless Apple CarPlay[®] and Android Auto[™] integration, SiriusXM² with 360L including 4-month trial subscription and SiriusXM Travel Link^{®11} trial, Subaru Live Traffic including 1-year trial subscription,¹² USB-A and USB-C input ports, and Bluetooth[®]
- Harman Kardon[®] 576-watt-equivalent premium audio system with 11 speakers
- DriverFocus Distraction Mitigation System¹³
- Smart Rear-View Mirror
- 360-degree Surround-View Monitor
- Reverse Automatic Braking¹⁰
- EyeSight Driver Assist Technology³ with Automatic Emergency Steering⁸



- 182-hp 2.5-liter 4-cylinder SUBARU BOXER engine with direct injection and auto start-stop technology
- Subaru Symmetrical All-Wheel Drive with Active Torque Vectoring
- 17-inch aluminum-alloy wheels with matte black finish
- Yokohama[®] Geolandar[®] All-Terrain tires
- 9.2 inches of ground clearance
- Dual-function X-MODE with Hill Descent Control
- Enhanced Lineartronic CVT gearing and rear differential
- 3,000-lb. towing capacity¹
- SI-DRIVE with Sport Sharp (S#) mode
- Engine skid plate
- Hexagonal LED fog lights
- Forester Wilderness exterior underguards, fender flares and side cladding
- Forester Wilderness-design front grille
- Matte-black, anti-glare hood decal
- Subaru Wilderness badging
- Anodized Copper-finish wider roof rails with increased static load-carrying capacity
- Full-size spare tire
- Forester Wilderness Gray StarTex water-repellent upholstery
- Forester Wilderness all-weather floor mats
- SUBARU STARLINK 8.0-inch Multimedia Plus with Apple CarPlay[®] and Android Auto[™] integration, SiriusXM² including 4-month trial and 3-year SiriusXM Traffic¹¹ and SiriusXM Travel Link^{®11} trial subscriptions, 6 speakers, dual USB-A input ports and Bluetooth[®]
- EyeSight Driver Assist Technology³: Pre-Collision Braking System, Pre-Collision Throttle Management, Lane Departure and Sway Warning with Lane Departure Prevention, Advanced Adaptive Cruise Control with Lane Centering and Automatic Emergency Steering⁸
- Dual-zone automatic climate control system
- 180-degree Front View Monitor
- 10-way power-adjustable driver seat with 2-way lumbar support
- All-Weather Package: Heated exterior mirrors, 3-mode heated front seats, windshield wiper de-icer
- One-touch folding rear seatback
- Cargo-area tray
- Blind-Spot Detection with Lane Change Assist and Rear Cross-Traffic Alert⁷
- Reverse Automatic Braking¹⁰

Optional Package

Option Package (OP 22): • SUBARU STARLINK 8.0-inch Multimedia Navigation System with 3-year SiriusXM Traffic¹¹ and SiriusXM Travel Link^{®11} trials • Harman Kardon[®] premium audio system with 9 speakers • Power Rear Gate



Information current at time of printing.

Visit www.subaru.com for the most up-to-date product information.

2025 Forester | Specifications

Engine and Drivetrain

Engine Power | Torque 2.5-liter DOHC direct injection aluminum-alloy 16-valve 4-cylinder horizontally opposed SUBARU BOXER engine with Dual Active Valve Control System (DAVCS).
Forester, Forester Premium, Forester Sport, Forester Limited and Forester Touring: 180 hp @ 5,800 rpm | 178 lb-ft @ 3,700 rpm
2024 Forester Wilderness: 182 hp @ 5,800 rpm | 176 lb-ft @ 4,400 rpm

SI-DRIVE Engine Performance Management Subaru Intelligent Drive (SI-DRIVE) enables two distinctively different modes of vehicle performance characteristics by regulating the engine control unit (ECU) and the transmission control unit (TCU) as well as fine-tuning the electronically controlled throttle.
Forester, Forester Premium, Forester Limited, Forester Sport and Forester Touring: Intelligent (I) and Sport (S); **Forester Sport OP 24 and 2024 Forester Wilderness:** Intelligent (I) and Sport Sharp (S#)

Forester

2024 Forester Wilderness

Traction and Stability

X-MODE X-MODE optimizes engine output and transmission ratio, increases all-wheel drive system engagement and uses enhanced control of the Vehicle Dynamics Control (VDC) system to reduce or increase individual wheelspin, providing optimal traction on various types of terrain and low-friction surfaces.
Forester: N/A.
Forester Premium: Standard. Single-mode system.
Forester Sport, Forester Limited, Forester Touring and Forester Wilderness: Standard. Dual-mode system with Snow/Dirt and Deep Snow/Mud modes.

Hill Descent Control (HDC) X-MODE also incorporates Hill Descent Control, which helps to maintain a constant vehicle speed when traveling downhill, enhancing vehicle control.
Forester: N/A.
Forester Premium, Forester Sport, Forester Limited, Forester Touring and 2024 Forester Wilderness: Standard.

Active Torque Vectoring Active Torque Vectoring works in tandem with VDC, applying braking power to the inside wheels, resulting in sharper turn-in, more neutral steering and higher cornering limit while turning.



Subaru. Lowest Ownership Cost, according to IntelliChoice.¹⁵



Subaru is rated #1 in safety for four years running.¹⁶

2025 Forester | Specifications

Traction and Stability (continued)

		Forester	2024 Forester Wilderness
Trailer Stability Assist (TSA)	Trailer Stability Assist senses any unsafe yaw conditions and automatically applies braking to specific wheels to help the driver maintain vehicle control.	●	●

Fuel

Fuel Economy	city/highway/combined ¹⁴	26/33/29 mpg Forester Sport/ Touring: 25/32/28 mpg	25/28/26 mpg
Fuel Requirement	Unleaded gasoline (87 octane)	●	●
Fuel Capacity	16.6 gallons	●	●

Chassis

Steering	Electric power-assisted rack-and-pinion steering (EPAS). Turning circle: 35.4 feet.	●	●
Suspension	4-wheel independent raised suspension. Front: Strut-type with lower L-arm. Stabilizer bar. Rear: Double wishbone. Stabilizer bar.	●	●
Brakes	4-wheel disc. Ventilated front and rear. 4-channel, 4-sensor ABS with Electronic Brake-force Distribution (EBD).	●	●
Brake Discs (front/rear)	12.4 inches/11.8 inches. 2024 Forester Wilderness: 12.4 inches/11.2 inches.	●	●
Brake Override System	If both brake and accelerator pedals are pressed simultaneously, the system reduces the operation of the accelerator pedal to help prevent unintentional vehicle acceleration.	●	●

● Standard ○ Optional

15 | 2025 Forester



96% of Subaru Forester vehicles sold in the last 10 years are still on the road today.¹⁷



The 2023 Subaru Forester is top ranked in its class, according to MotorTrend.¹⁸

2025 Forester | Equipment

	Forester	Forester Premium	Forester Sport	Forester Limited	Forester Touring	2024 Forester Wilderness
Exterior						
LED fog lights	□	●	●	●	●	●
Panoramic moonroof (100% UV light-reducing) ¹⁹	—	●	●	●	●	●
Windshield wiper de-icer and heated exterior mirrors (All-Weather Package)	—	●	●	●	●	●
Seating and Trim						
6-way manually adjustable driver seat and 4-way manually adjustable front-passenger seat	●	—	—	—	—	—
10-way power-adjustable driver seat with power-adjustable lumbar support	—	●	●	●	●	●
8-way power-adjustable front-passenger seat	—	—	—	●	●	—
2-position driver seat memory with exterior mirror synchronization	—	—	—	—	●	—
Heated steering wheel	—	—	—	●	●	—
Heated front seats (All-Weather Package)	—	●	●	●	●	●
Ventilated front seats	—	—	—	—	●	—
Convenience Features						
Keyless Access with Push-Button Start	—	●	●	●	●	●
Hands-Free Power Rear Gate ⁹ with automatic close, height memory functions and lock switch	—	○ ²⁰	○ ²⁰	●	●	—
Dual rear USB-A and USB-C charge ports (2024 Forester Wilderness: Dual USB-A charge ports)	—	●	●	●	●	●
Cargo-area cover	□	●	●	●	●	●
Audio and Communication Systems						
SUBARU STARLINK Dual 7.0-inch Multimedia with Apple CarPlay [®] and Android Auto [™] integration, SiriusXM ² including 4-month trial subscription and SiriusXM Travel Link ^{®11} trial, USB-A input port and Bluetooth [®]	●	—	—	—	—	—
SUBARU STARLINK 11.6-inch Multimedia Plus with wireless Apple CarPlay [®] and Android Auto [™] integration, SiriusXM ² with 360L including 4-month trial subscription and SiriusXM Travel Link ^{®11} trial, USB-A and USB-C input ports, and Bluetooth [®]	—	●	●	●	—	—



2025 Forester | Equipment

Audio and Communication Systems (continued)

	Forester	Forester Premium	Forester Sport	Forester Limited	Forester Touring	2024 Forester Wilderness
SUBARU STARLINK 11.6-inch Multimedia Navigation System with 3 years of free map updates, wireless Apple CarPlay® and Android Auto™ integration, SiriusXM² with 360L including 4-month trial subscription and SiriusXM Travel Link®¹¹ trial, Subaru Live Traffic including 1-year trial subscription,¹² USB-A and USB-C input ports, and Bluetooth®	—	—	—	○²⁰	●	—
SUBARU STARLINK 8.0-inch Multimedia Plus with Apple CarPlay® and Android Auto™ integration, SiriusXM² including 4-month trial subscription and SiriusXM Travel Link®¹¹ trial, high-resolution LCD touchscreen display, AM/FM, HD Radio®, dual USB-A input ports and Bluetooth®	—	—	—	—	—	●
SUBARU STARLINK 8.0-inch Multimedia Navigation System with Apple CarPlay® and Android Auto™ integration, SiriusXM² including 4-month trial subscription and SiriusXM Traffic¹¹ and SiriusXM Travel Link®¹¹ trials, high-resolution LCD display, voice-activated controls, AM/FM, HD Radio®, dual USB-A input ports and Bluetooth®	—	—	—	—	—	○²⁰
4 speakers	●	—	—	—	—	—
6 speakers	—	●	●	●	—	●
Harman Kardon® premium audio system with 11 speakers and 576-watt-equivalent amplifier	—	—	○²⁰	○²⁰	●	—
Harman Kardon® premium audio system with 9 speakers and 576-watt-equivalent amplifier	—	—	—	—	—	○²⁰

Safety

ACTIVE						
Subaru Symmetrical All-Wheel Drive (AWD)	●	●	●	●	●	●
Blind-Spot Detection with Lane Change Assist and Rear Cross-Traffic Alert⁷	—	○²⁰	●	●	●	●
Reverse Automatic Braking (RAB)¹⁰	—	—	○²⁰	○²⁰	●	●
DriverFocus Distraction Mitigation System (DMS)¹³	—	—	—	—	●	—
360-degree Surround-View Monitor	—	—	—	—	●	—

● Standard ○ Optional — Not equipped □ Available retailer-installed accessory



Protecting Your Investment

Once you're part of our family, we'll be there for you. Every Subaru comes with 24-hour roadside assistance for 3 years or 36,000 miles. And to protect you over the long haul, we offer Added Security[®], which helps protect your car for up to 10 years or 100,000 miles with extended service agreements and maintenance plans backed by Subaru. And because we've been backing them for more than 30 years, they're agreements you can trust. Your retailer has full coverage details.



More Than a Car Company[®].



**THE SUBARU
LOVE PROMISE**

For us, love is about the commitments we make. The Subaru Love Promise[®] is our vision to show love and respect to all people and the planet we all share. Subaru is headquartered in a zero-landfill office in Camden, N.J., and in 2004, Subaru of Indiana Automotive, Inc. (SIA) became the first manufacturing facility in the U.S. to reach zero-landfill status—nothing from its manufacturing efforts ever goes into a landfill.

**SUBARU
Loves the
Earth**



**SUBARU
Loves to
Care**



**SUBARU
Loves to
Help**



**SUBARU
Loves
Learning**



**SUBARU
Loves
Pets**



Warranties

New Car Limited Warranty	3 years or 36,000 miles, whichever comes first.	
Powertrain Limited Warranty	5 years or 60,000 miles, whichever comes first.	
Wear Item Limited Warranty	3 years or 36,000 miles, whichever comes first. Repairs to the following items will also be covered under Wear Item Limited Warranty:	<ul style="list-style-type: none"> • Brake Pads • Wiper Blades • Transmitter Batteries
Rust Perforation Limited Warranty	5 years, unlimited mileage.	
24-hour Roadside Assistance	3 years or 36,000 miles, whichever comes first.	

1 Maximum towing capacity varies by trim level. Trailer brakes may be needed. Do not use with any type of weight-distributing hitch as their usage has not been validated to work with Subaru vehicles. Some safety features, including Blind-Spot Detection, Rear Cross-Traffic Alert, Smart Rear-View Mirror and X-MODE, may not function properly during towing. See your Owner's Manual for details. 2 All SiriusXM services require a subscription, sold separately by SiriusXM after the trial period. Your SiriusXM service will automatically stop at the end of your trial unless you decide to subscribe. If you decide to continue service after the trial, the subscription plan chosen will automatically renew and be charged according to your chosen payment method at the then-current rates. Fees and taxes apply. See the SiriusXM Customer Agreement & Privacy Policy at www.siriusxm.com for full terms and how to cancel, which includes online methods or calling 1-866-635-2349. Available in the 48 contiguous United States, D.C., and Puerto Rico (with coverage limits and capable receiver). Visit www.siriusxm.com/FACS for most current service area information. Availability of some services and features is subject to device capabilities and location restrictions. All fees, content and features are subject to change. SiriusXM, SiriusXM Traffic, SiriusXM Travel Link[®] and all related logos are trademarks of Sirius XM Radio Inc. and its respective subsidiaries. Other marks, channel names and logos are the property of their respective owners. All rights reserved. SiriusXM with 360L: Certain features and/or content may not be available unless an active data connection is enabled in the vehicle. Content varies by SiriusXM subscription. Features may vary by make/model. 3 EyeSight is a driver assist technology, which may not operate optimally under all driving conditions. The driver is always responsible for safe and attentive driving. System effectiveness depends on many factors such as vehicle maintenance, weather and road conditions. The Pre-Collision Braking System is designed to provide automatic braking that either prevents a collision or reduces the severity of a frontal impact. Pre-Collision Throttle Management is designed to reduce acceleration and minimize the severity of certain frontal impacts. Advanced Adaptive Cruise Control, Brake Light Recognition and Automatic Emergency Steering are designed to assist the driver and are not substitutes for safe and attentive driving. Automatic Emergency Steering availability varies by trim level and works in conjunction with and after Pre-Collision Braking has been activated by providing steering support at speeds lower than 50 mph to try and help avoid a collision. Lane centering function operates only when used in conjunction with Advanced Adaptive Cruise Control. Lane Departure and Sway Warning with Lane Departure Prevention operates only when the lane markings are visible, and its effectiveness depends on many factors. See your Owner's Manual for complete details on system operation and limitations. 4 The Supplemental Restraint System (SRS) (airbags) affords the driver and the front and rear outboard passengers additional protection in moderate to severe frontal and side-impact collisions. This system provides supplemental protection only, and seatbelts must be worn in order to avoid injuries to out-of-position occupants upon airbag deployment and to provide the best combined protection in a serious accident. Children should always be properly restrained in the rear seat. 5 Activation and subscription required. Internet access is purchased separately through AT&T with monthly, per gigabyte, and unlimited data options available. Existing AT&T customers have the option to add a line to their AT&T Mobile Share plan. See your Subaru retailer for details. 6 Qi[®] wireless charging may not be compatible with all mobile devices. When using the wireless charging system, avoid placing metal objects between the wireless charger and the mobile device when charging is active. Doing so may cause metal objects to become hot and could cause burns. 7 Blind-Spot Detection, Lane Change Assist and Rear Cross-Traffic Alert are systems designed to assist the driver by monitoring the rear and side areas of the vehicle during a lane change or reversing and are not a substitute for safe and attentive driving. 8 Automatic Emergency Steering is a system designed to assist the driver. It is not a substitute for safe and attentive driving. Automatic Emergency Steering requires Blind-Spot Detection and works in conjunction with and after Pre-Collision Braking has been activated by providing steering support at speeds lower than 60 mph to try and help avoid a collision. See your Owner's Manual for complete details, including important system limitations. Availability varies by trim level. 9 Foot activation function not operable when equipped with accessory tow hitch. See your Subaru retailer for details. 10 The Reverse Automatic Braking System is not a substitute for safe and attentive driving. System effectiveness depends on many factors, such as vehicle maintenance, weather and road conditions. Always exercise caution and use vehicle mirrors and the Rear-View Camera when backing up. See your Owner's Manual for complete details on system operation and limitations. 11 Activation and monthly subscription sold separately. Includes 3-year trial subscription. See your Subaru retailer for details. 12 All Subaru Live Traffic services require a subscription after the trial period. Subaru Live Traffic services will automatically renew at the end of the trial period into a monthly paid plan unless the trial is cancelled. Subaru Live Traffic can be cancelled at any time by going to the Manage Subscriptions page of the MySubaru app. Upon cancelling, the subscription will continue to the end of the paid term and not renew. There are no refunds available. Fees and taxes apply. Services are only available while traveling in the United States, including Hawaii and Alaska, and in Canada. Availability of some services and features is subject to device capabilities and location restrictions. All fees, content and features are subject to change. 13 The DriverFocus Distraction Mitigation System is a driver recognition technology designed to alert drivers if their attention to the road wavers or if the driver's face appears to turn away. The driver is always responsible for safe and attentive driving. System effectiveness may be affected by articles of clothing worn on the head or face. See your Owner's Manual for complete details on system operation and limitations. 14 2024 EPA fuel economy estimates. Actual mileage may vary. 15 2023 IntelliChoice 5-Year Cost of Ownership Study © 2024 MOTOR TREND GROUP, LLC. 16 Compared to all other measured mass-market automotive companies in the 2023 American Customer Satisfaction Index (ACSI) surveys of customers rating their own automotive company's performance. ACSI and its logo are registered trademarks of the American Customer Satisfaction Index, LLC. 17 Based on Experian Automotive vehicles in operation vs. total new registrations for MY2014-2023 as of December 2023. 18 MOTOR TREND Buyer's Guide Ultimate Car Rankings Spring-Summer 2023 © 2024 MOTOR TREND GROUP, LLC. 19 The glass information listed represents calculated reference values and may not represent actual values determined by testing. 20 Available only with other features. See Optional Equipment listing. 21 Activation with subscription required. Includes a 3-year trial subscription to STARLINK Safety Plus services and a 6-month trial subscription to STARLINK Safety and Security Plus services. The Concierge plan can be purchased annually or monthly. A credit card on file will be required for specific packages and for renewal purposes. Not available in all states. See your Subaru retailer for details.

2025 Forester | Dimensions

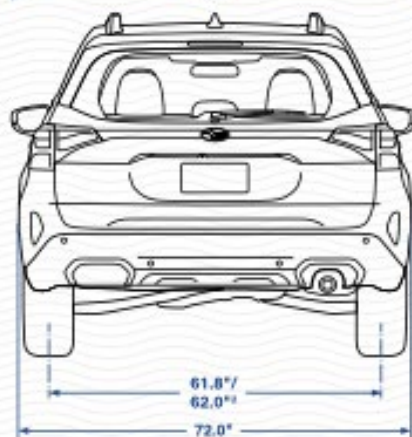
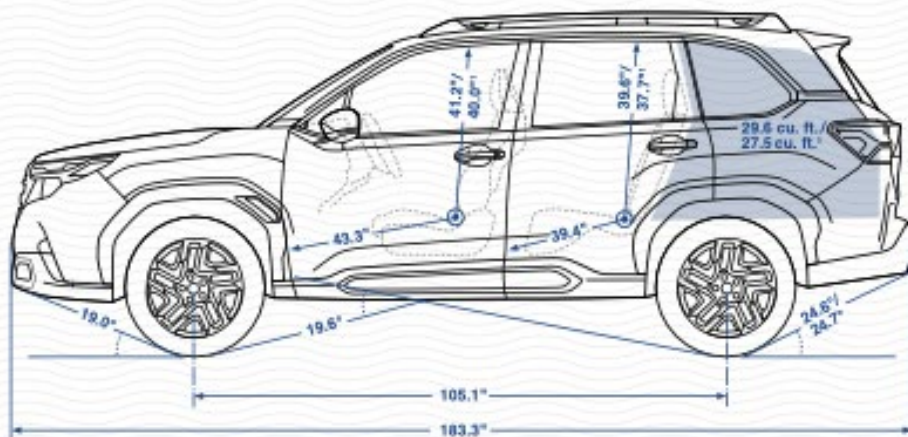
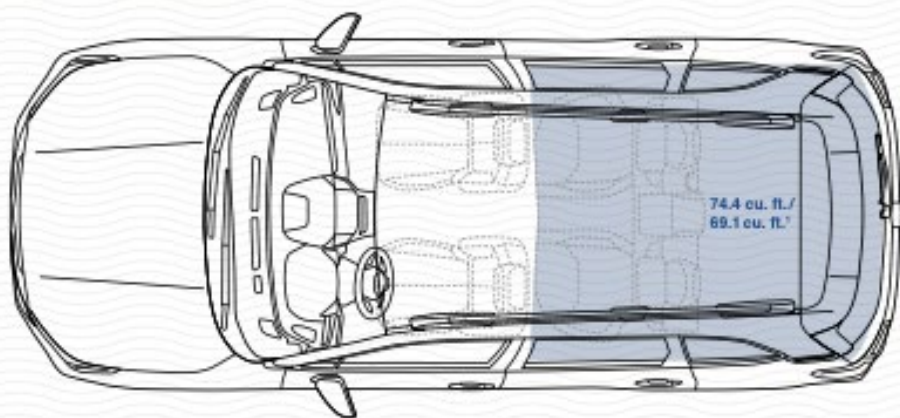

Length	183.3 inches	Ground clearance	8.7 inches (at base curb weight) 2024 Forester Wilderness: 9.2 inches
Width	72.0 inches (81.2 inches with exterior mirrors) 2024 Forester Wilderness: 72.2 inches (81.3 inches with exterior mirrors)	Headroom (front/rear)	40.0 inches/37.7 inches (without moonroof: 41.2 inches/39.6 inches) 2024 Forester Wilderness: 40.2 inches/37.6 inches
Height	68.1 inches with roof rails 2024 Forester Wilderness: 68.9 inches	Legroom (front/rear)	43.3 inches/39.4 inches 2024 Forester Wilderness: 43.3 inches/39.4 inches
Wheelbase	105.1 inches 2024 Forester Wilderness: 104.9 inches	Shoulder room (front/rear)	57.7 inches/56.7 inches 2024 Forester Wilderness: 58.1 inches/57.2 inches
Track (front/rear)	61.6 inches/61.8 inches Sport / Touring: 61.8 inches/62.0 inches 2024 Forester Wilderness: 61.4 inches/61.4 inches	Hip room (front/rear)	54.7 inches/53.7 inches 2024 Forester Wilderness: 54.5 inches/53.5 inches
Base curb weight	Forester: 3,510 lbs. Forester Premium: 3,569 lbs. Forester Sport: 3,611 lbs. Forester Limited: 3,613 lbs. Forester Touring: 3,664 lbs. 2024 Forester Wilderness: 3,620 lbs.	Passenger volume	106.6 cubic feet (without moonroof: 110.8 cubic feet) 2024 Forester Wilderness: 107.6 cubic feet
		Cargo volume	27.5 cubic feet (without moonroof: 29.6 cubic feet) 2024 Forester Wilderness: 26.9 cubic feet
		Maximum cargo volume	69.1 cubic feet with rear seat lowered (without moonroof: 74.4 cubic feet) 2024 Forester Wilderness: 69.1 cubic feet

1 With available moonroof. Moonroof availability varies by trim level. 2 Forester Sport and Touring trim levels.

Some images shown are for illustration purposes only. Specifications and imagery in this brochure are based on the latest product information available at the time of publication. Production models may vary. For the most up-to-date and detailed product information, log on to www.subaru.com. Some equipment shown in photography in this brochure is optional at extra cost. Specific options may be available only in combination with other options. Specific combinations of equipment or features may vary from time to time and by geographic area. Certain accessories and equipment may not be available at the time of publication. Subaru of America, Inc., reserves the right to change or discontinue at any time, without notice, prices, colors, materials, equipment, accessories, specifications, models and packages without incurring any obligation to make the same or similar changes on vehicles previously sold. Colors shown may vary due to reproduction and printing processes.

This brochure was prepared by Subaru of America, Inc. Every owner of the car during the warranty period shall be entitled to the benefit of these warranties. EyeSight, Lineartronic, SI-DRIVE, Subaru, SUBARU STARLINK, STARLINK, SUBARU BOXER, X-MODE and Wilderness are registered trademarks of Subaru Corporation. Added Security, DriverFocus, Forester, Love, it's what makes Subaru, Subaru, Love Promise, More Than a Car Company, StarTex, Subaru Loves Learning, Subaru Loves Pets, Subaru Loves the Earth, Subaru Loves to Care and Subaru Loves to Help are registered trademarks of Subaru of America, Inc. ACSP® and its logo are registered trademarks of The American Customer Satisfaction Index, LLC. Apple CarPlay® is a registered trademark of Apple, Inc. Bluetooth® is a registered trademark of Bluetooth SIG, Inc. Experian® and its logo are registered trademarks of Experian Information Solutions, Inc. Forest Stewardship Council®, FSC® and the FSC® checkmark-and-tree logo are registered trademarks of Forest Stewardship Council AC. Google, Android, Android Auto, and Google Play are trademarks of Google LLC. Harman Kardon® is a registered trademark of Harman International Industries, Incorporated. HD Radio® is a registered trademark of iBiquity Digital Corporation. HomeLink® and the HomeLink® house icon are registered trademarks of Gentex Corporation. IHHS™ is a trademark of the Insurance Institute for Highway Safety. Motor Trend® and IntelliChoice® are registered trademarks of Motor Trend Group, LLC. Qi® is a registered trademark of Wireless Power Consortium, Inc. SleepyPod® is a registered trademark of Launchlab Corp. SiriusXM, SiriusXM Traffic, SiriusXM Travel Link® and all related logos are trademarks of Sirius XM Radio Inc. and its respective subsidiaries. Other marks, channel names and logos are the property of their respective owners. All rights reserved. Thule® is a registered trademark of the Thule Group. Ultrasuede® is a registered trademark of Toray Industries, Inc. Yokohama® and Geolandar® are registered trademarks of Yokohama Tire Company. For more information, contact your Subaru retailer, or log on to www.subaru.com.

2025 Forester | Colors

Paint



Crystal White
Pearl



Ice Silver
Metallic



Brilliant Bronze
Metallic



Autumn Green
Metallic



River Rock
Pearl



Geyser Blue¹



Horizon Blue
Pearl



Crimson Red
Pearl



Magnetite Gray
Metallic



Sapphire Blue
Pearl



Crystal Black
Silica

Upholstery



Gray Cloth
(GC)



Premium Black Cloth
(PBC)

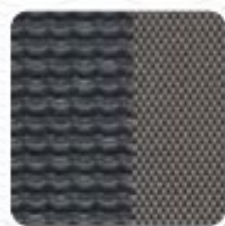

Premium Gray Cloth
(PGC)



Gray Sport StarTex
(GSS)



Gray Leather
(GL)



Black Leather
(BL)



Touring Brown Leather
(TBR)



Touring Black Leather
(TBL)



Gray Textured StarTex¹
(GTT)

Color Combinations

Color Combinations	Forester	Forester Premium	Forester Sport	Forester Limited	Forester Touring	2024 Forester Wilderness
Crystal White Pearl	GC	PBC or PGC	GSS	BL or GL	TBL or TBR	GTT
Ice Silver Metallic	—	PBC	—	BL	TBL or TBR	GTT
Brilliant Bronze Metallic	—	PBC	—	BL	TBL or TBR	—
Autumn Green Metallic	—	PBC	—	BL	TBL or TBR	GTT
River Rock Pearl	—	PBC	GSS	BL	TBL or TBR	—
Geyser Blue	—	—	—	—	—	GTT
Horizon Blue Pearl	GC	PGC	—	GL	TBR	—
Crimson Red Pearl	GC	PGC	—	GL	TBR	—
Magnetite Gray Metallic	GC	PBC or PGC	GSS	BL or GL	TBL or TBR	GTT
Sapphire Blue Pearl	—	—	GSS	—	—	—
Crystal Black Silica	—	PBC	GSS	BL	TBL or TBR	GTT

¹ 2024 Forester Wilderness trim only.

— Not available

See the Forester and Wilderness trim in action

 youtube.com/subaru



2024 Forester Wilderness shown

These brochures were printed with vegetable-based inks and produced using a "Green Printing Process." The Forest Stewardship Council® (FSC®) is an international organization that brings people together to find solutions which promote responsible stewardship of the world's forests and environments.

By producing these brochures in a green way rather than by traditional methods, we saved 82 trees preserved for the future; 19,000 gallons of wastewater flow saved; 300 lbs solid waste not generated; 48,000 lbs net greenhouse gases prevented; 37,000,000 BTUs energy not consumed. Calculations provided by Environmental Paper Network. FSC® is not responsible for any calculations on saving resources by choosing this paper.

This brochure is printed in the U.S.A. on 10% recycled paper. © 2024 Subaru of America, Inc. 25.FORSRB.025 (D36N-P399, 173K, 5/24, KSL)

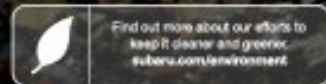

Love. It's what makes Subaru, Subaru.®

