

2026 - 2028



**PROTOCOL
CRASH AVOIDANCE
FRONTAL COLLISIONS**



ANCAP
SAFETY

v1.0
May 2025



PREFACE

During test preparation, vehicle manufacturers are encouraged to liaise with ANCAP and to observe the way the vehicle is set up for testing. Where a vehicle manufacturer feels that a particular aspect should be altered, they should raise this with the ANCAP assessor present at the test, or in writing to the ANCAP Chief Executive Officer if no assessor is present. ANCAP will consider the matter and at their sole discretion give direction to the test facility.

Vehicle manufacturers warrant not to, whether directly or indirectly, interfere with testing and are forbidden from making changes to any aspect that may influence the test, including but not limited to dummy positioning, vehicle setting, laboratory environment etc.

Illustrations in this protocol are reproduced from Euro NCAP publications, and therefore show Euro NCAP markings on left-hand-drive vehicles. Where relevant, the layouts depicted should be adapted to right-hand-drive application.

VERSION

VERSION	PUBLISHED	DETAILS
1.0	May 2025	First ANCAP version of protocol

DISCLAIMER

ANCAP has taken all reasonable care to ensure that the information published in this protocol is accurate and reflects the current technical decisions taken by the organisation. In the event this protocol contains an error or inaccuracy, ANCAP reserves the right to make corrections and determine the assessment and subsequent result of the affected requirement(s).

COPYRIGHT

Copyright 2025. This work is the intellectual property of ANCAP with certain content reproduced with the permission of Euro NCAP. A license is granted for this material to be shared for non-commercial, educational purposes, provided this copyright statement appears on the reproduced materials and notice is given that the copying is by permission of ANCAP. To disseminate otherwise or to republish will be considered a breach of intellectual property rights.

CONTENTS

DEFINITIONS	2
1 MEASURING EQUIPMENT	7
1.1 Reference system	7
1.2 VUT longitudinal path error	8
1.3 VUT Lateral Path Error	9
1.4 Test paths for turning scenarios	10
1.5 Impact location	11
1.6 Targets	14
1.7 Measurements and variables	18
2 TEST CONDITIONS	20
2.1 Test track	20
2.2 Weather Conditions	21
2.3 VUT Preparation	22
3 TEST PROCEDURE	25
3.1 Car & PTW Scenarios	25
3.2 Pedestrian & Cyclist Scenarios	37
4 TEST EXECUTION	51
4.1 Performance Predictions	51
4.2 Verification tests	52
4.3 Test Conduct	54
5 ASSESSMENT	56
5.1 General requirements	56
5.2 Criteria	56
5.3 Scoring	62
5.4 Links to Driver State	65
APPENDIX A APPLICABILITY OF ROBUSTNESS LAYERS	67
APPENDIX B OBSTRUCTION DIMENTIONS	71

DEFINITIONS

Throughout this protocol the following terms are used:

Peak Braking Coefficient (PBC) – the measure of tyre to road surface friction based on the maximum deceleration of a rolling tyre, measured using the method as specified in UNECE R13-H.

Vehicle under test (VUT) – means the vehicle tested according to this protocol with a pre-crash collision mitigation or avoidance system on board.

Global Vehicle Target (GVT) – means the vehicle target used in this protocol as defined in ISO 19206-3:2021

Secondary Other Vehicle (SOV) – means the vehicle being overtaken by VUT in CCFhol scenario. This vehicle can either be a GVT or a real vehicle.

Euro NCAP Pedestrian Target (EPTa) – means the articulated adult pedestrian target used in this protocol as specified in ISO 19206-2:2018

Euro NCAP Bicyclist Target (EBTa) – means the adult bicyclist and bike target used in this protocol as specified in ISO 19206-4:2020

Euro NCAP Child Target (EPTc) – means the articulated child pedestrian target used in this protocol as specified in ISO 19206-2:2018

Euro NCAP Motorcyclist Target (EMT) – means the Motorcyclist target used in this protocol as specified in ISO 19206-5.

Real Motorcycle – Means a motorcyclist target that can be used in the Blind-Spot Monitoring Tests of this protocol, as an alternative to the EMT. The Real Motorcycle shall be a type approved two-wheeled motorcycle, with a maximum speed of at least 80km/h by design, without front fairing or windshield. It shall closely resemble the EMT (as specified in section 2.1 of [deliverable D2.1 of the MUSE project](#)), thus staying within the mean dimensions of the most registered middleweight naked motorcycles (i.e. wheelbase >1405mm. and <1445mm.).

Autonomous Emergency Braking (AEB) – braking that is applied automatically by the vehicle in response to the detection of a likely collision to reduce the vehicle speed and potentially avoid the collision.

Forward Collision Warning (FCW) – an audio-visual warning that is provided automatically by the vehicle in response to the detection of a likely collision to alert the driver.

Autonomous Emergency Steering (AES) – steering that is applied automatically by the vehicle in response to the detection of a likely collision to steer the vehicle and potentially avoid the collision.

Emergency Steering Support (ESS) – a system that supports the driver steering input in response to the detection of a likely collision to alter the vehicle path and potentially avoid a collision.

Vehicle width – the widest point of the vehicle ignoring the rear-view mirrors, side marker lamps, tyre pressure indicators, direction indicator lamps, position lamps, flexible mud-guards and the deflected part of the tyre side-walls immediately above the point of contact with the ground.

Car-to-Pedestrian – a collision between a vehicle and an adult or child pedestrian in its path, when no braking and/or steering action is applied.

Car-to-Bicyclist – a collision between a vehicle and an adult bicyclist in its path, when no braking and/or steering is applied.

Car-to-Motorcyclist – a collision between a vehicle and a Motorcyclist in its path, when no braking and/or steering is applied.

Standard range – refers to the most basic and controlled format a test scenario will be tested. Tests within the standard range are deemed the foundational level performance expectations for any given test scenario.

Extended range – refers to test points in which minor levels of complexity are introduced to the standard range tests. Changes for this range are limited to variations in impact position and longitudinal velocity for the VUT and / or test target.

Robustness layer – refers to the introduction of test complexity and variation, designed to challenge vehicle systems and encourage reliable “real-world” performance.

Time To Collision (TTC) – means the remaining time before the VUT strikes the test target, assuming that the VUT and test target would continue to travel with the speed it is travelling.

T_{AEB} – means the time where the AEB system activates. Activation time is determined by identifying the last data point where the filtered acceleration signal is below -3 m/s^2 , and then going back to the point in time where the acceleration first crossed -1 m/s^2

T_{FCW} – means the time where the audible warning of the FCW starts. The starting point is determined by audible recognition.

T_{Diver_steer} – means the time where the control handover from the steering robot to the test driver starts. From that point, the test driver shall hold the steering wheel in a neutral position resembling naturalistic driving and avoiding overly harsh/aggressive inputs.

T_{Driver_throttle} – means the time where the control handover from the accelerator robot to the test driver starts. From that point, the test driver shall manually control the target vehicle speed with the accelerator pedal, resembling naturalistic driving and avoiding overly harsh/aggressive inputs.

V_{impact} – means the speed at which the profiled line around the front or rear end of the VUT coincides with the virtual box around the test targets (platform not included in the virtual box) EPTa, EPTc, EBTa and EMT as shown in the right part of the figures below, as illustrated in Figure 0- and Figure 0-.

V_{rel_test} – means the relative speed between the VUT and the test target (GVT, EPT, EBT or EMT) by subtracting the longitudinal velocity of the test target from that of the VUT at the start of test.

V_{rel_impact} – means the relative speed at which the VUT hits the test target (GVT, EPT, EBT or EMT) by subtracting the longitudinal velocity of the test target from V_{impact} at the time of collision.

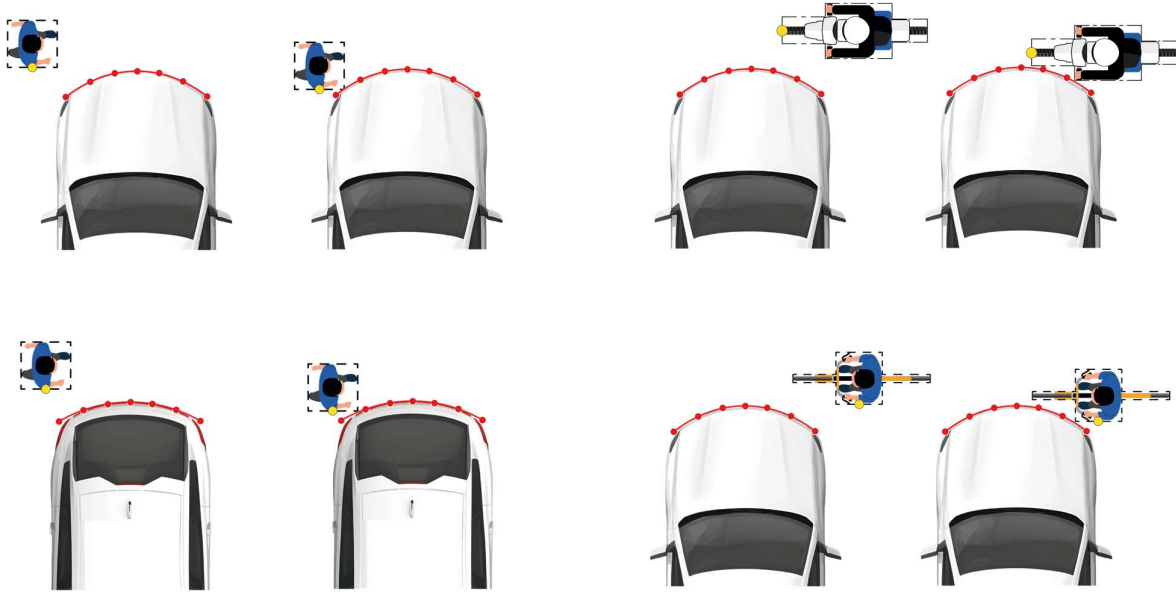

Figure 0-1 :Front end profile vs EPT, EMT, and EBT targets, and rear end profile vs EPT target.

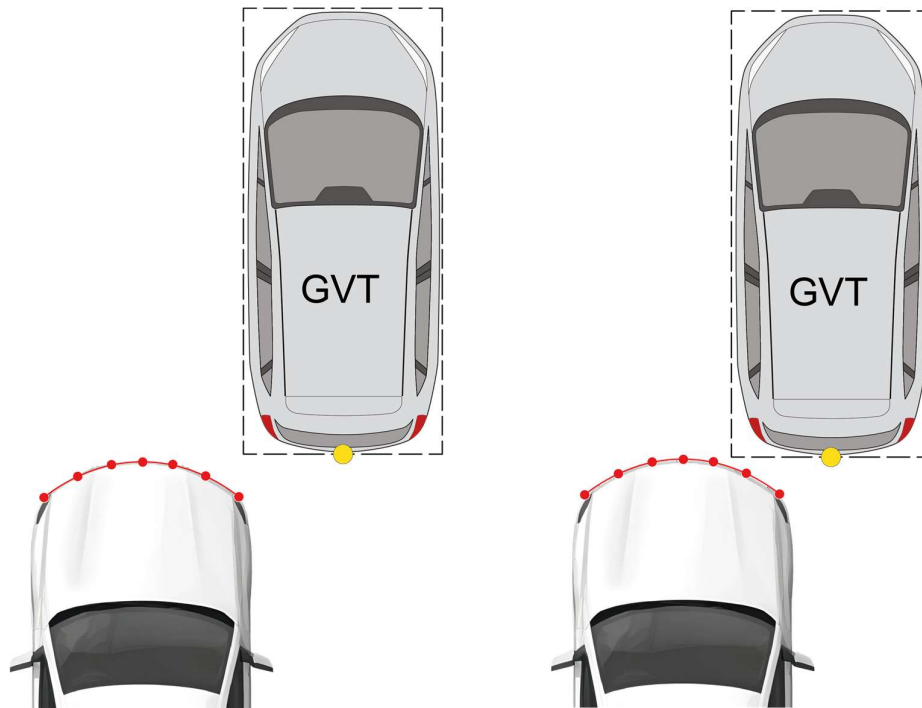

Figure 0-2 Front end profile and GVT

Test Scenarios

Car-to-Pedestrian Farside Adult (CPFA) – a collision in which a vehicle travels forwards towards an adult pedestrian crossing its path running from the farside and the frontal structure of the vehicle strikes the pedestrian when no braking action is applied.

Car-to-Pedestrian Nearside Adult (CPNA) – a collision in which a vehicle travels forwards towards an adult pedestrian crossing its path walking from the nearside and the frontal structure of the vehicle strikes the pedestrian when no braking action is applied.

Car-to-Pedestrian Nearside Child Obstructed (CPNCO) – a collision in which a vehicle travels forwards towards a child pedestrian crossing its path running from behind and obstruction from the nearside and the frontal structure of the vehicle strikes the pedestrian when no braking action is applied.

Car-to-Pedestrian Longitudinal Adult (CPLA) – a collision in which a vehicle travels forwards towards an adult pedestrian walking in the same direction in front of the vehicle where the vehicle strikes the pedestrian when no braking action is applied or an evasive steering action is initiated after an FCW.

Car-to-Pedestrian Longitudinal Adult (CPLA) – a collision in which a vehicle travels forwards towards an adult pedestrian walking in the same direction in front of the vehicle where the vehicle strikes the pedestrian when no braking action is applied.

Car-to-Pedestrian Turning Adult (CPTA) – a collision in which a vehicle turns towards an adult pedestrian crossing its path, walking across a junction (in either the same and opposite direction as the VUT, before the VUT made the turn) and the frontal structure of the vehicle strikes the pedestrian at 50% of the vehicle's width when no braking action is applied.

Car-to-Bicyclist Nearside Adult (CBNA) – a collision in which a vehicle travels forwards towards a bicyclist crossing its path cycling from the nearside and the frontal structure of the vehicle strikes the bicyclist when no braking action is applied.

Car-to-Bicyclist Nearside Adult Obstructed (CBNAO) – a collision in which a vehicle travels forwards towards a bicyclist crossing its path cycling from the nearside from behind an obstruction and the frontal structure of the vehicle strikes the bicyclist when no braking action is applied.

Car-to-Bicyclist Farside Adult (CBFA) – a collision in which a vehicle travels forwards towards a bicyclist crossing its path cycling from the farside and the frontal structure of the vehicle strikes the bicyclist when no braking action is applied.

Car-to-Bicyclist Longitudinal Adult (CBLA) – a collision in which a vehicle travels forwards towards a bicyclist cycling in the same direction in front of the vehicle where the vehicle would strike the cyclist when no braking action is applied or an evasive steering action is initiated after an FCW.

Car-to-Bicyclist Longitudinal Adult (CBLA) – a collision in which a vehicle travels forwards towards a bicyclist cycling in the same direction in front of the vehicle where the vehicle would strike the cyclist when no braking action is applied.

Car-to-Bicyclist Turning Adult (CBTA) – a collision in which a vehicle turns towards a bicyclist crossing its path, cycling in the opposite direction across a junction and the frontal structure of the vehicle strikes the cyclist when no braking action is applied.

Car-to-Motorcyclist Rear Stationary (CMRs) – a collision in which a vehicle travels forwards towards a motorcyclist and the front structure of the vehicle strikes the rear of the motorcycle.

Car-to-Motorcyclist Rear Braking (CMRb) – a collision in which a vehicle travels forwards towards a motorcyclist that is travelling at constant speed and then decelerates, and the frontal structure of the vehicle strikes the rear of the motorcycle.

Car-to-Motorcyclist Front Turn Across Path (CMFtap) – a collision in which a vehicle turns across the path of an oncoming motorcyclist travelling at a constant speed, and the frontal structure of the vehicle strikes the front of the motorcycle.

Car-to-Motorcyclist Crossing Straight Crossing Path (CMCscp) – a collision in which a vehicle travels forwards along a straight path across a junction, towards a motorcyclist crossing the junction on a perpendicular path. The frontal structure of the vehicle under test strikes the side of the other vehicle.

Car-to-Car Rear Stationary (CCRs) – a collision in which a vehicle travels forwards towards another stationary vehicle and the frontal structure of the vehicle strikes the rear structure of the other.

Car-to-Car Rear Moving (CCRm) – a collision in which a vehicle travels forwards towards another vehicle that is travelling at constant speed and the frontal structure of the vehicle strikes the rear structure of the other.

Car-to-Car Rear Braking (CCRb) – a collision in which a vehicle travels forwards towards another vehicle that is travelling at constant speed and then decelerates, and the frontal structure of the vehicle strikes the rear structure of the other.

Car-to-Car Front Turn-Across-Path (CCFtap) – a collision in which a vehicle turns across the path of an oncoming vehicle travelling at constant speed, and the frontal structure of the vehicle strikes the front structure of the other.

Car-to-Car Crossing Straight Crossing Path (CCCscp) – a collision in which a vehicle travels forwards along a straight path across a junction, towards a vehicle crossing the junction on a perpendicular path. The frontal structure of the vehicle under test strikes the side of the other vehicle.

Car-to-Car Front Head-On Straight (CCFhos) – a collision where a vehicle is travelling along a straight path within its defined lane and strikes another vehicle travelling in the opposite direction, which has drifted into the same lane as the original vehicle. The frontal structure of the vehicle strikes the frontal structure of the other.

Car-to-Car Front Head-On Lane change (CCFhol) – a collision where a vehicle is travelling along a straight path within its defined lane and strikes another vehicle travelling in the opposite direction which has intentionally moved into the lane of the original vehicle to attempt an overtake. The frontal structure of the vehicle strikes the frontal structure of the other.

1 MEASURING EQUIPMENT

1.1 Reference system

Use the convention specified in ISO 8855:2011, with the origin at the most forward point on the centreline of the VUT for dynamic data measurements as shown in Figure 1-1. This reference system should be used for both left- and right-hand drive vehicles. In Figure 1-1 nearside and far-side are shown for a left-hand drive vehicle. For a right-hand drive vehicle, nearside and far-side are swapped.

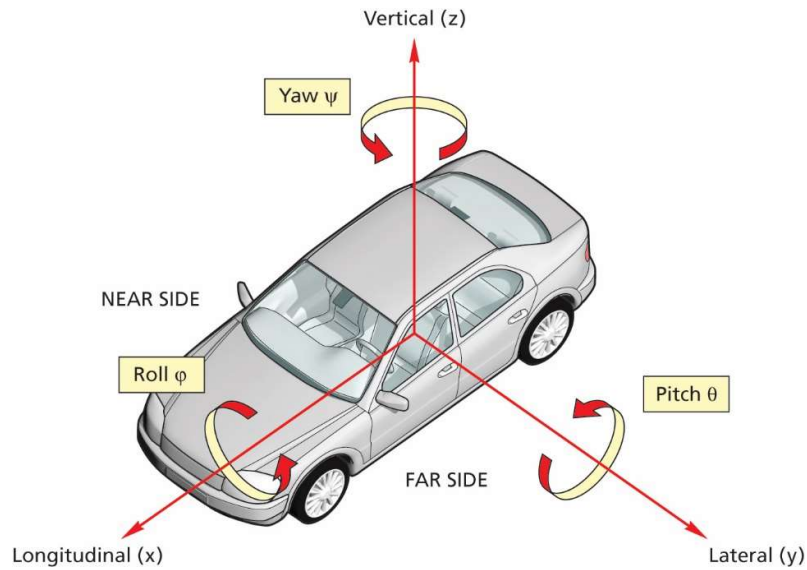

Figure 1-1 Coordinate system and notation

1.2 VUT longitudinal path error

1.2.1 Car-to-Car

The VUT longitudinal path error is determined as the difference between the desired position and the actual position of the front of the VUT when measured at a single defined “stable” position of the front of the GVT during the test.

$$\text{VUT longitudinal path error} = X_{\text{VUT, desired}} - X_{\text{VUT, actual}} (@X_{\text{GVT}})$$

For CCFtap, when the origin of the reference system is at the intended collision point, the values shown in the table below shall be used to determine the VUT longitudinal path error.

VUT speed	Target speed	$X_{\text{VUT, desired}}$	X_{GVT}
10 km/h	30 km/h		29.17 m
	45 km/h	-9.57 m	43.75 m
	60 km/h		58.33 m
15 km/h	30 km/h		29.17 m
	45 km/h	-14.53 m	43.75 m
	60 km/h		58.33 m
20 km/h	30 km/h		29.17 m
	45 km/h	-19.47 m	43.75 m
	60 km/h		58.33 m
25 km/h	30 km/h		29.17 m
	45 km/h	-24.33 m	43.75 m
	60 km/h		58.33 m

1.2.2 Car-to-Motorcycle

For CMFtap scenario, the VUT longitudinal path error is determined as the difference between the desired position and the actual position of the front of the VUT when measured at a single defined “stable” position of the front of the EMT during the test.

$$\text{VUT longitudinal path error} = X_{\text{VUT, desired}} - X_{\text{VUT, actual}} (@X_{\text{EMT}})$$

When the origin of the reference system is at the intended collision point, the values shown in the table below shall be used to determine the VUT longitudinal path error.

VUT speed	Target speed	$X_{VUT, \text{desired}}$	X_{EMT}
10 km/h	30 km/h		33.33 m
	45 km/h	-10.66 m	50.00 m
	60 km/h		66.66 m
15 km/h	30 km/h		33.33 m
	45 km/h	-16.39 m	50.00 m
	60 km/h		66.66 m
20 km/h	30 km/h		33.33 m
	45 km/h	-22.02 m	50.00 m
	60 km/h		66.66 m
25 km/h	30 km/h		33.33 m
	45 km/h	-27.60 m	50.00 m
	60 km/h		66.66 m

1.3 VUT Lateral Path Error

The lateral offset ($Y_{VUT\text{-error}}$) is determined as the lateral distance between the centre of the front axle of the VUT when measured in parallel to the intended path as shown in Figure 1-2 VUT Lateral Path Error.

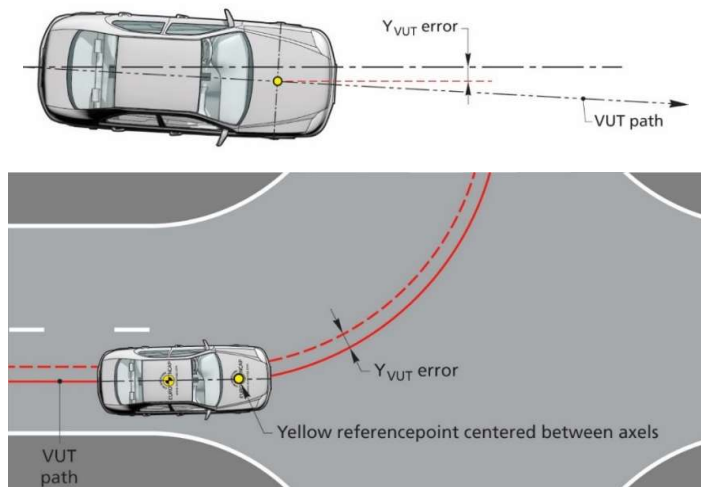
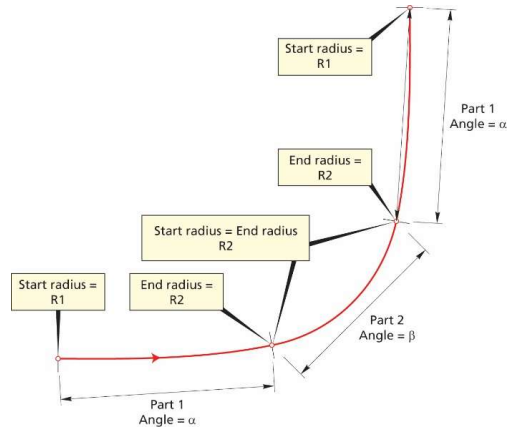

Figure 1-2 VUT Lateral Path Error

1.4 Test paths for turning scenarios

For CPTA, CBTA, CCFtap and CMFtap, the following parameters should be used to create the test paths.



Test Speed	Part 1 (Clothoid)			Part 2 (constant radius)			Part 3 (Clothoid)		
	Start Radius R1 [m]	End Radius R2 [m]	Angle α [deg]	Start Radius R1 [m]	End Radius R2 [m]	Angle β [deg]	Start Radius R2 [m]	End Radius R1 [m]	Angle α [deg]
10 km/h to Farside	1500	9.00	20.62	9.00	9.00	48.75	9.00	1500	20.62
15 km/h to Farside	1500	11.75	20.93	11.75	11.75	48.14	11.75	1500	20.93
20 and 25 km/h to Farside	1500	14.75	21.79	14.75	14.75	46.42	14.75	1500	21.79
10 km/h to Nearside	1500	8.00	22.85	8.00	8.00	44.30	8.00	1500	22.85

1.5 Impact location

Impact location is defined as where the reference point of the target coincides with the %-age of the VUT width.

1.5.1 Car-to-Car Rear

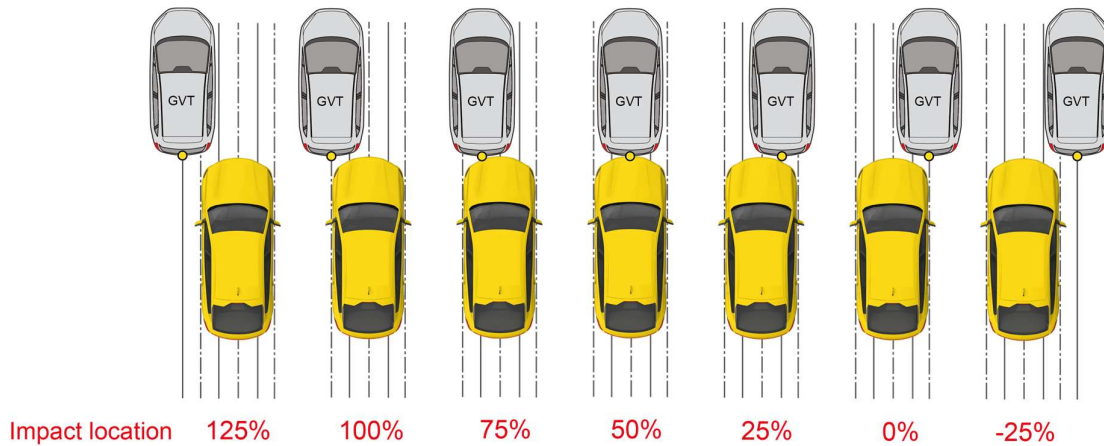

1.5.2 Car-to-car Rear + Heading

Rotation by target reference point, dependent on combination of VUT impact location and rotation direction, collision may occur with corner edge before impact location and target reference point contact:

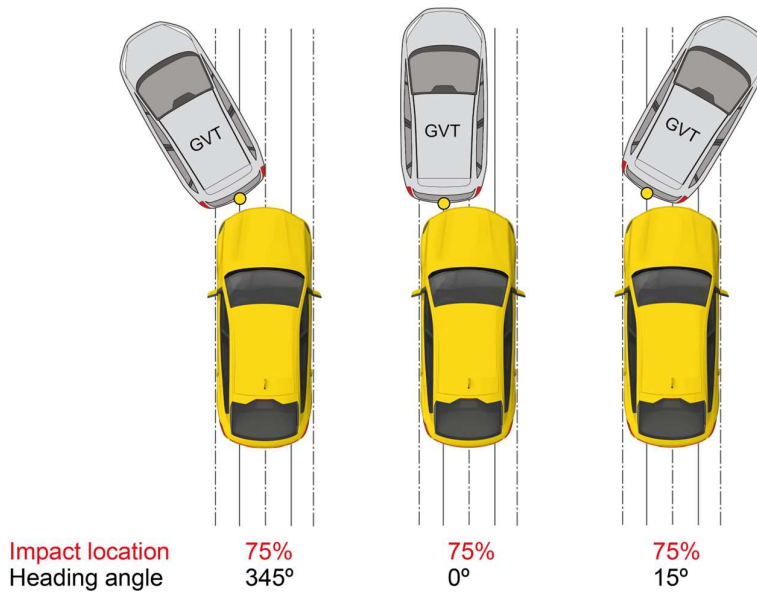

1.5.3 Car-to-Car Front

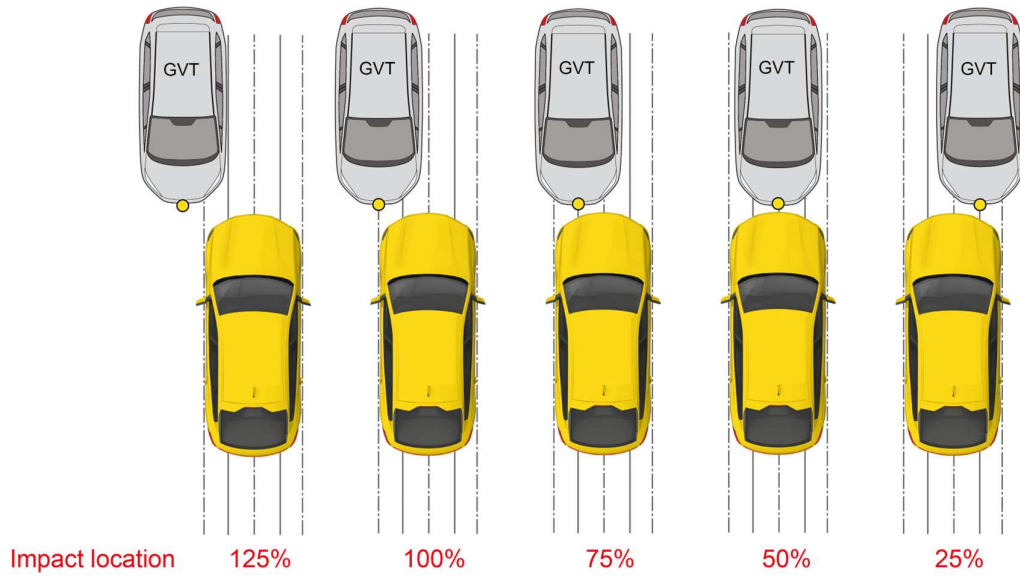

1.5.4 Car-to-Car Crossing

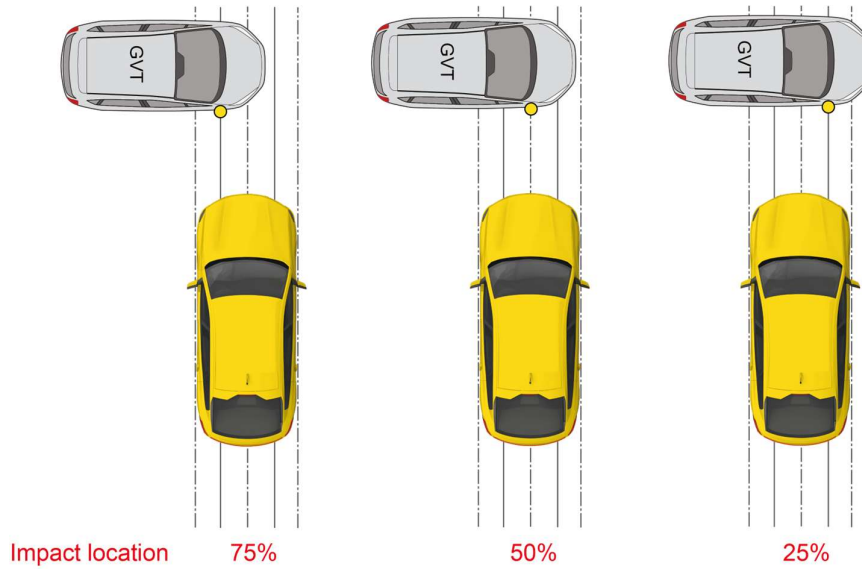

1.5.5 Car-to-Car Turn Across Path

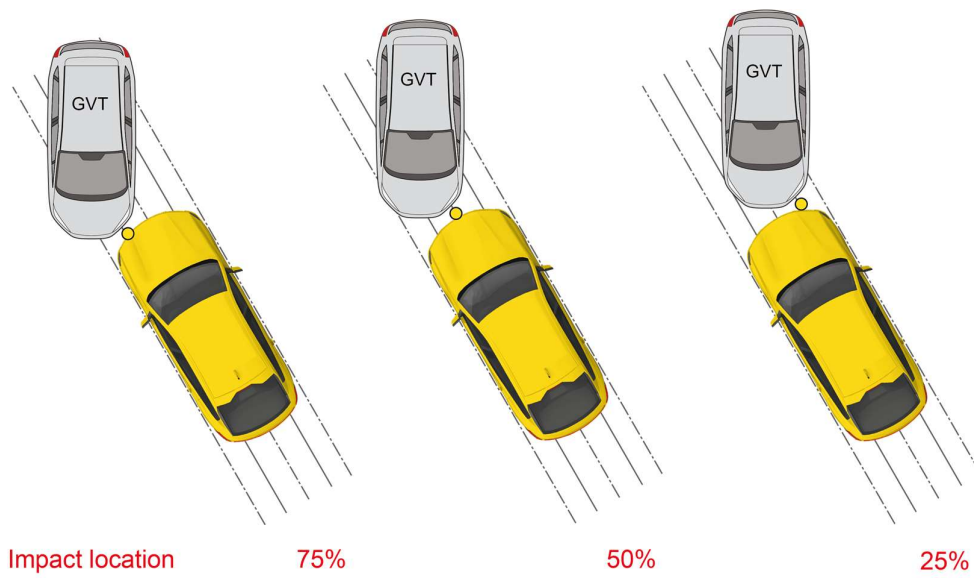

1.5.6 Car-to-PTW Crossing

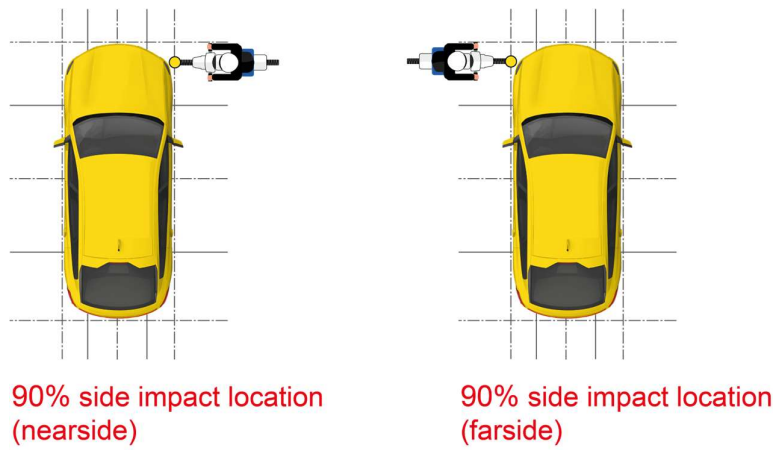

1.5.7 Car-to-Bicyclist Turning

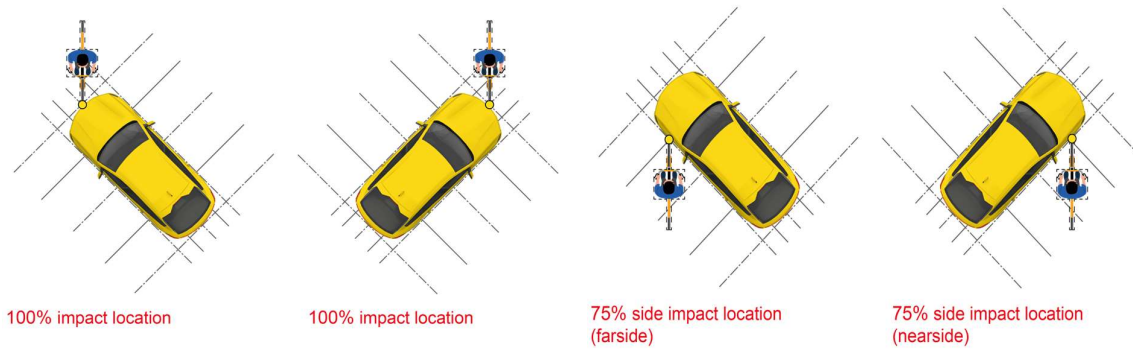

1.6 Targets

Only equipment listed in the current version of Euro NCAP [TB029 - Suppliers List](#) may be used for testing. The current version can be found on the Euro NCAP website.

1.6.1 Virtual Boxes

For each test target, a virtual box defined will be used to determine the impact speed. The dimensions of these virtual boxes are shown in the figures below, along with impact reference points related to each test target.

Impact location descriptions in 0 and scenario descriptions in 3 illustrate which of the reference points is to be utilised for each specific scenario.

1.6.1.1 VUT

A virtual profiled line is defined around both the front end and the rear end of the VUT, as well as around the right and left side of the VUT. These lines are defined by straight line segments connecting seven points that are equally distributed over the vehicle width minus 50mm on each side, and over the vehicle length minus 50mm on each side. The theoretical x,y coordinates are provided by the OEMs and verified by the test laboratory.

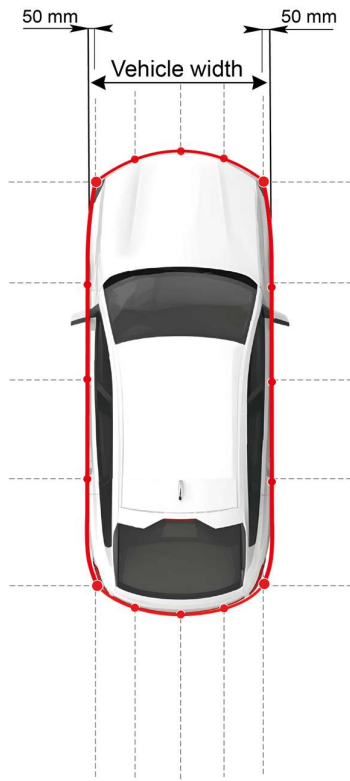

Figure 1-3 Virtual profiled line around the front end, rear end of the VUT

1.6.1.2 EPTa and EPTc

The dimensions of this virtual box are shown in the figure below, with reference points on the hip and a virtual point where the centreline of the dummy crosses the virtual box.

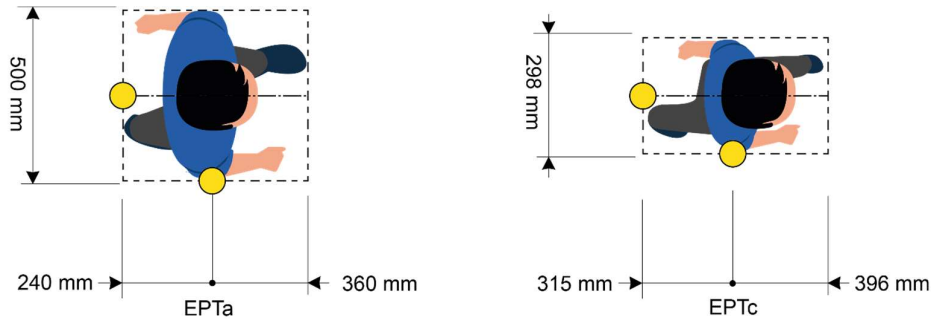

Figure 1.2.1: Virtual box dimensions around EPTa and EPTc

1.6.1.3 EBT

The dimensions of this virtual box are shown in the figure below, with reference points on the crank shaft (applicable to crossing scenarios), most forward point on the front wheel (applicable to turning scenarios) and most rearward point on the rear wheel (applicable to longitudinal scenarios).

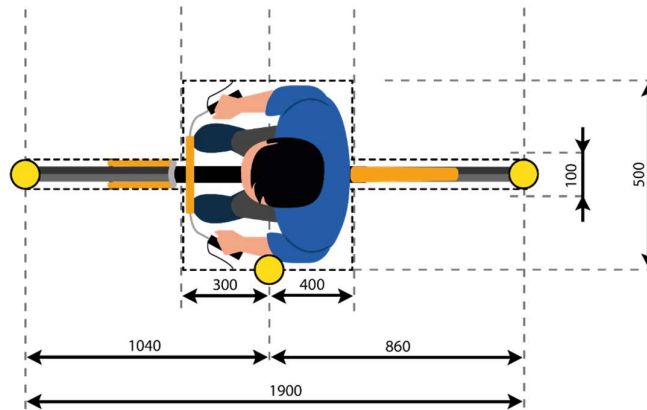

Figure 1.2.2: Virtual box dimensions around EBT

1.6.1.4 EMT

The dimensions of this virtual box are shown in the figure below with reference points on the most forward point on the front wheel (applicable to longitudinal-front, turning and crossing scenarios) and most rearward point on the rear wheel (applicable to longitudinal-rear scenarios).

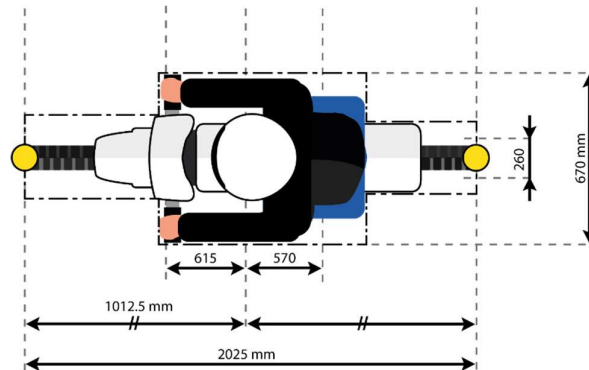

Figure 1.2.3: Virtual box dimensions around EMT

1.6.1.5 GVT

The virtual box of the GVT is shown in the figure below, with reference points on: the most forward point on the front profile (1 in the centre and 1 in the intersection of the front profile and each of the side profiles), the most rearward point on the rear profile (in the centre), and at 75% along the length of each side of the GVT.

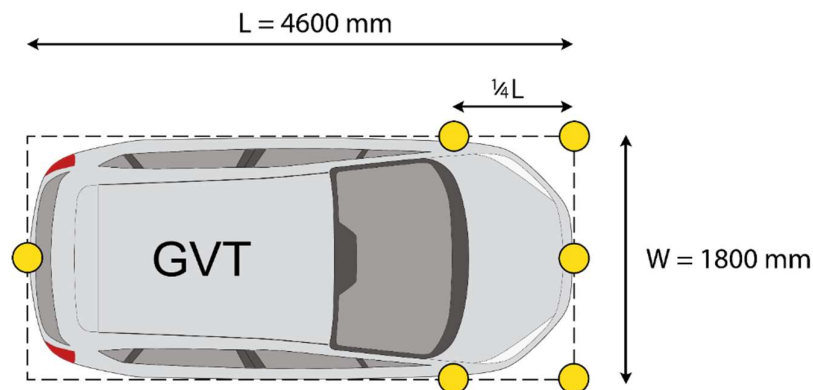

Figure 1.2.4: Virtual box dimensions around the GVT

1.7 Measurements and variables

Sample and record all dynamic data at a frequency of at least 100Hz. Synchronise using the DGPS time stamp the target data with that of the VUT.

1.7.1 Variables

Variable	Description
T	Time
T₀	Time of test start $T_0 = TTC$ 4s, unless stated otherwise <ul style="list-style-type: none"> - Turning scenarios: $T_0 = T_{steer} - 1s$ - Braking scenarios: $T_0 = T_{Target_deceleration_start} - 1s$ - Crossing scenarios: $T_0 = 0.5s$ after target acceleration phase
T_{AEB}	Time where AEB activates
T_{FCW}	Time where FCW activates
T_{impact}	Time where the VUT impacts the target
T_{steer}	Time where the VUT enters in curve segment
T_{Target_deceleration_start}	Time where the target starts decelerating
V_{impact}	Speed when the VUT impacts the target
V_{rel_impact}	Relative speed when the VUT impacts the target
X_{VUT}, Y_{VUT}	Position of the VUT during the entire test
V_{VUT}	Speed of the VUT during the entire test
A_{VUT}	Acceleration of the VUT during the entire test
Ψ_{VUT}	Yaw velocity of the VUT during the entire test
Ω_{VUT}	Steering wheel velocity of the VUT during the entire test
X_{target}, Y_{target}	Position of the target during the entire test
V_{target}	Speed of the target during the entire test
A_{target}	Acceleration of the target during the entire test
Ψ_{target}	Yaw velocity of the target during the entire test

1.7.2 Measurements

Equip the VUT and GVT with data measurement and acquisition equipment to sample and record data with an accuracy of at least:

- VUT and target speed to 0.1km/h
- VUT and target lateral and longitudinal position to 0.03m
- VUT heading angle to 0.1°
- VUT and target yaw rate to 0.1°/s
- VUT and target longitudinal acceleration to 0.1m/s²
- VUT steering wheel velocity to 1.0 °/s

1.7.3 Data Filtering

Filter the measured data as follows:

- Position and speed are not filtered and are used in their raw state.
- Acceleration, yaw rate, steering wheel velocity and force are filtered with a 12-pole phase less Butterworth filter with a cut off frequency of 10Hz.

2 TEST CONDITIONS

2.1 Test track

Conduct tests on a dry (no visible moisture on the surface), uniform, solid paved surface with a maximum longitudinal slope of $\pm 1\%$ and a maximum lateral slope of $\pm 3\%$. The test surface shall have a minimal peak braking coefficient (PBC) of 0.9.

The test track surface must be paved and may not contain irregularities (e.g. large dips or cracks, manhole covers or reflective studs) that may give rise to abnormal sensor measurements within a lateral distance of 5.0m to either side of the test path, and with a longitudinal distance of 20m ahead of the VUT when the test ends.

Unless otherwise specified, conduct testing such that, between T_0 and the test end, there are no other vehicles, infrastructure (except lighting columns during the low ambient lighting condition tests), obstructions, other objects or persons which may give rise to abnormal sensor measurements within the visual axis of the VUT and test target, and 20m ahead of the VUT at test end.

The general view ahead and to either side of the test area shall not comprise of any highly reflective surfaces or contain any silhouettes similar in shape to the test target.

2.1.1 Lane Markings

The presence of lane markings is allowed for AEB tests. However, testing may only be conducted in an area where typical road markings depicting a driving lane may not be parallel to the test path within 3.0m either side. Lines or markings may cross the test path but may not be present in the area where AEB activation and/or braking after FCW is expected.

Some scenarios described in this document require the use of a junction, where this is the case the scenario description will illustrate the scenario on a junction as in Figure 4.2. The main approach lane where the VUT path starts, (horizontal lanes in Figure 4.2) will have a width of 3.5m. The side lane (vertical lanes in Figure 4.2) will have a width of 3.25 to 3.5m. The lane markings on these lanes need to conform to one of the lane markings as defined in UNECE Regulation 130:

- Dashed line starting at the same point where the radius transitions into a straight line with a width between 0.10 and 0.15m
- Solid line with a width between 0.10 and 0.25m
- Junction without any central markings

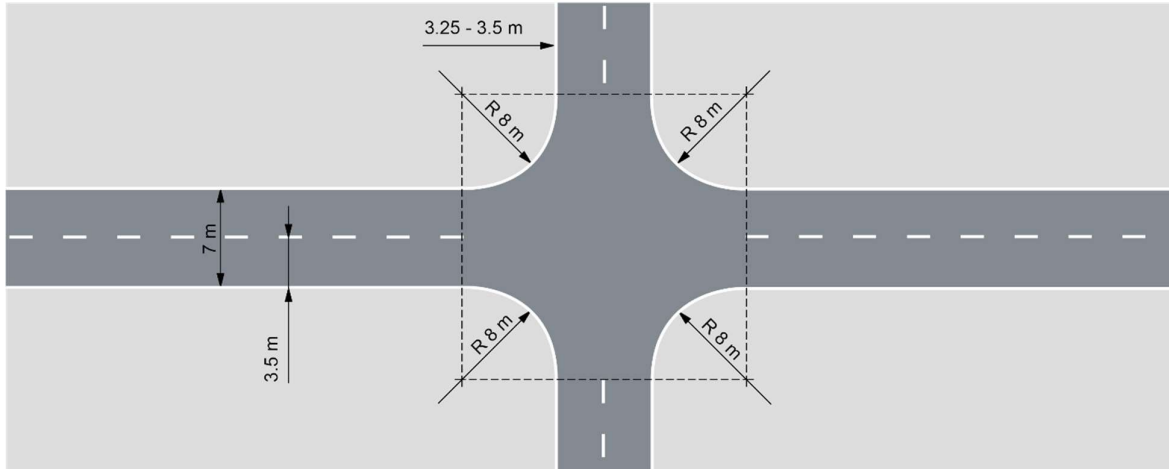

Figure 4.2: Layout of junction and the connecting lanes

2.2 Weather Conditions

Conduct tests in dry conditions with ambient temperature above 5°C and below 40°C.

No precipitation shall be falling and horizontal visibility at ground level shall be greater than 1km. Wind speeds shall be below 10m/s to minimise Target and VUT disturbance.

Natural ambient illumination must be homogenous in the test area and in excess of 2000 lux for daylight testing with no strong shadows cast across the test area other than those caused by the VUT or Target. Ensure testing is not performed driving towards, or away from the sun when there is direct sunlight.

Measure and record the following parameters preferably at the commencement of every single test or at least every 30 minutes:

- Ambient temperature in °C
- Track Temperature in °C
- Wind speed and direction in m/s
- Ambient illumination in Lux

2.3 Surroundings

Conduct testing such that there are no other vehicles, highway infrastructure (except lighting columns during the low ambient lighting condition tests), obstructions, other objects or persons protruding above the test surface, that may give rise to abnormal sensor measurements during the full duration of the test starting at T0 and within a longitudinal distance 20m ahead of the VUT when the test ends, within:

- 5m either side of the VUT test path,
- a circle around the GVT, and
- The visual axis between the geometric centre of the VUT and the circle surrounding the GVT.

- For CCCscp only, the above applies from TTC =3.5s (instead of T0).

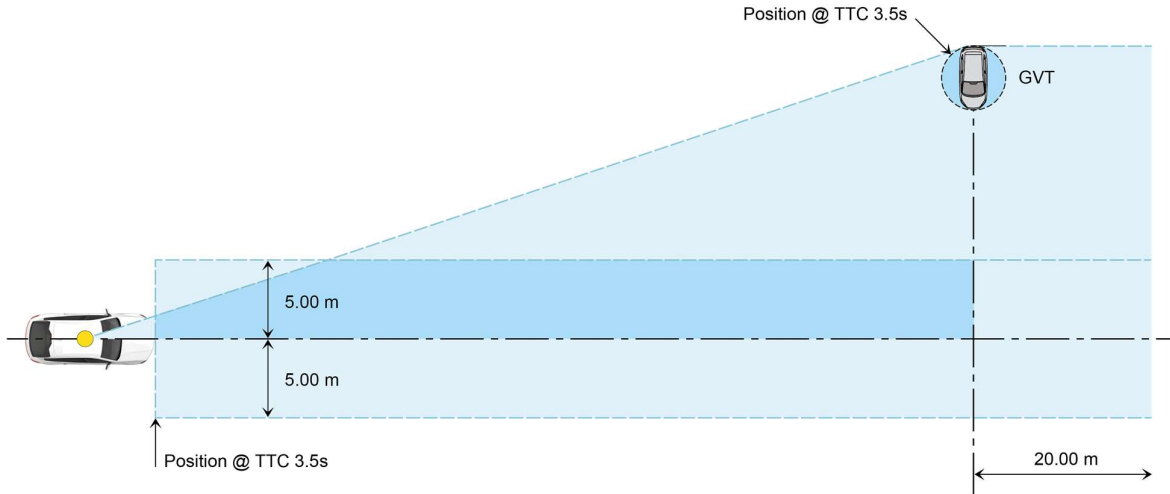

Figure 2-1 Free space requirements – CCCscp Farside Test

Test areas where the VUT needs to pass under overhead signs, bridges, gantries or other significant structures are not permitted.

The general view ahead and to either side of the test area shall comprise of a wholly plain man made or natural environment (e.g. further test surface, plain coloured fencing or hoardings, natural vegetation or sky etc.) and must not comprise any highly reflective surfaces or contain any vehicle-like silhouettes that may give rise to abnormal sensor measurements.

2.4 VUT Preparation

2.4.1 System Settings

Set any driver configurable elements of the AEB and/or FCW system (e.g. the timing of the collision warning or the braking application if present) to the middle setting or midpoint and then next latest setting similar to the examples shown in Figure 4.4.

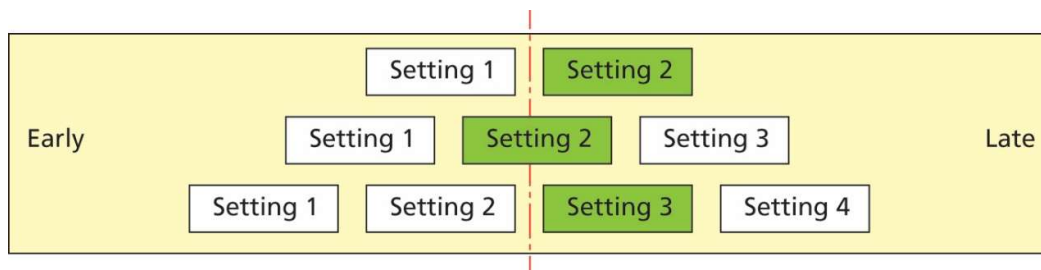

Figure 4.4: AEB and/or FCW system setting for testing

When the vehicle is equipped with a Driver State Monitoring (DSM) which alters the AEB and/or FCW sensitivity according to the driver's state (e.g. distracted / attentive), this system shall be deactivated before the testing commences.

When the vehicle is equipped with a deployable pedestrian/VRU protection system, this system shall be deactivated before the testing commences.

2.4.2 Tyres

Perform the testing with new original fitment tyres of the make, model, size, speed and load rating as specified by the vehicle manufacturer. It is permitted to change the tyres which are supplied by the manufacturer or acquired at an official dealer representing the manufacturer if those tyres are identical make, model, size, speed and load rating to the original fitment. Inflate the tyres to the vehicle manufacturer's recommended cold tyre inflation pressure(s). Use inflation pressures corresponding to least loading normal condition.

Run-in tyres according to the tyre conditioning procedure. After running-in maintain the run-in tyres in the same position on the vehicle for the duration of the testing.

2.4.3 Wheel Alignment Measurement and Unladen Kerb Mass

The vehicle should be subject to a vehicle (in-line) geometry check to record the wheel alignment set by the OEM. This should be done with the vehicle in kerb weight.

If applicable, fill up the tank with fuel to at least 90% of the tank's capacity of fuel.

Check the oil level and top up to its maximum level if necessary. Similarly, top up the levels of all other fluids to their maximum levels if necessary.

Ensure that the vehicle has its spare wheel on board, if fitted, along with any tools supplied with the vehicle. Nothing else should be in the car.

Ensure that all tyres are inflated according to the manufacturer's instructions for the appropriate loading condition.

Measure the front and rear axle masses and determine the total mass of the vehicle. The total mass is the 'unladen kerb mass' of the vehicle. Record this mass in the test details.

Calculate the required ballast mass, by subtracting the mass of the test driver and test equipment from the required 200 kg interior load.

2.4.4 Vehicle Preparation

Fit the on-board test equipment and instrumentation in the vehicle. Also fit any associated cables, cabling boxes and power sources and place weights with a mass of the ballast mass. Any items added should be securely attached to the car.

With the driver in the vehicle, weigh the front and rear axle loads of the vehicle and compare these loads with the "unladen kerb mass"

The total vehicle mass shall be within $\pm 1\%$ of the sum of the unladen kerb mass, plus 200kg. The front/rear axle load distribution needs to be within 5% of the front/rear axle load distribution of the original unladen kerb mass plus full fuel load. If the vehicle differs from the requirements given in this paragraph, items may be removed or added to the vehicle which has no influence on its

performance. Any items added to increase the vehicle mass should be securely attached to the car.

Care needs to be taken when adding or removing weight in order to approximate the original vehicle inertial properties as close as possible. Record the final axle loads in the test details. Record the axle weights of the VUT in the 'as tested' condition.

3 TEST PROCEDURE

Each scenario in this assessment consists of a matrix combining vehicle longitudinal speeds, and ranges of impact locations or target longitudinal speeds. Each combination in a matrix is referred to as grid cell. The grid cells forming a matrix are grouped into two groups:

	Standard Range
	Extended Range

3.1 Car & PTW Scenarios

Car & PTW Scenarios	Standard	Extended	Robustness	Total
Longitudinal				15.0
Car-to-Car Rear	5.2	0.65	0.65	
Car-to-Car Front	4.0	0.5	0.5	
Car-to-Motorcycle Rear	2.8	0.35	0.35	
Turning				10.0
Car-to-Car Turn Across Path	4.0	0.5	0.5	
Car-to-Motorcycle Turn Across Path	4.0	0.5	0.5	
Crossing				15.0
Car-to-Car Crossing	6	0.75	0.75	
Car-to-Motorcycle Crossing	6	0.75	0.75	

3.1.1 Longitudinal

Longitudinal	Standard	Extended	Robustness	Total
Car-to-Car-Rear				6.5
CCRs	1.2	0.15	0.15	
CCRm	2.4	0.3	0.3	
CCRb	1.6	0.2	0.2	
Car-to-Car-Front				5.0
CCFhos	2.0	0.25	0.25	
CCFhol	2.0	0.25	0.25	
Car-to-Motorcyclist Rear				3.5
CMRs	1.2	0.15	0.15	
CMRb	1.6	0.2	0.2	

3.1.1.1 Car-to-Car Rear

CCRs	GVT speed	Function	Impact Location						
			125%	100%	75%	50%	25%	0%	-25%
10 km/h	0 km/h	AEB							
20 km/h	0 km/h	AEB							
30 km/h	0 km/h	AEB							
40 km/h	0 km/h	AEB							
50 km/h	0 km/h	AEB							
60 km/h	0 km/h	FCW							
70 km/h	0 km/h	FCW							
80 km/h	0 km/h	FCW							

The Vehicle Manufacturer shall inform ANCAP whether the FCW cases are to be verified with FCW or AEB. Where the AEB system is able to avoid the collision in the FCW cases, the points are automatically awarded for the corresponding FCW test.

CCRm	GVT speed	Function	Impact Location						
			125%	100%	75%	50%	25%	0%	-25%
30 km/h	20 km/h	AEB							
40 km/h	20 km/h	AEB							
50 km/h	20 km/h	AEB							
60 km/h	20 km/h	AEB							
70 km/h	20 km/h	AEB							
80 km/h	20 km/h	AEB							
90 km/h	30 km/h	AEB							
100 km/h	40 km/h	AEB							
110 km/h	50 km/h	AEB							
120 km/h	60 km/h	AEB							
130 km/h	70 km/h	AEB							

CCRb	GVT speed	Function	Impact Location						
			125%	100%	75%	50%	25%	0%	-25%
30 km/h	30 km/h	AEB							
40 km/h	40 km/h	AEB							
50 km/h	50 km/h	AEB							
60 km/h	60 km/h	AEB							
70 km/h	70 km/h	AEB							
80 km/h	80 km/h	AEB							
90 km/h	90 km/h	AEB							
100 km/h	100 km/h	AEB							
110 km/h	110 km/h	AEB							
120 km/h	120 km/h	AEB							
130 km/h	130 km/h	AEB							

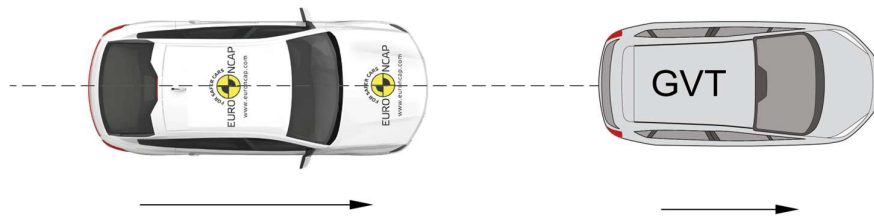

For CCRb, the Time Headway = 1.0 s, and the target acceleration = -4m/s^2 for both Standard Range and Extended Range.

The desired deceleration of the GVT shall be reached within 1.0 second ($T_0 + 2.0\text{s}$) which after the GVT shall remain within $\pm 0.5 \text{ km/h}$ of the reference speed profile, derived from the desired deceleration, until the vehicle speed equals 2km/h .

3.1.1.2 Car-to-Car Front

CCFhos	GVT speed	Impact Location			
		100%	75%	50%	25%
30 km/h	50 km/h				
40 km/h	50 km/h				
50 km/h	50 km/h				
60 km/h	70 km/h				
70 km/h	70 km/h				
80 km/h	70 km/h				
90 km/h	90 km/h				
100 km/h	100 km/h				

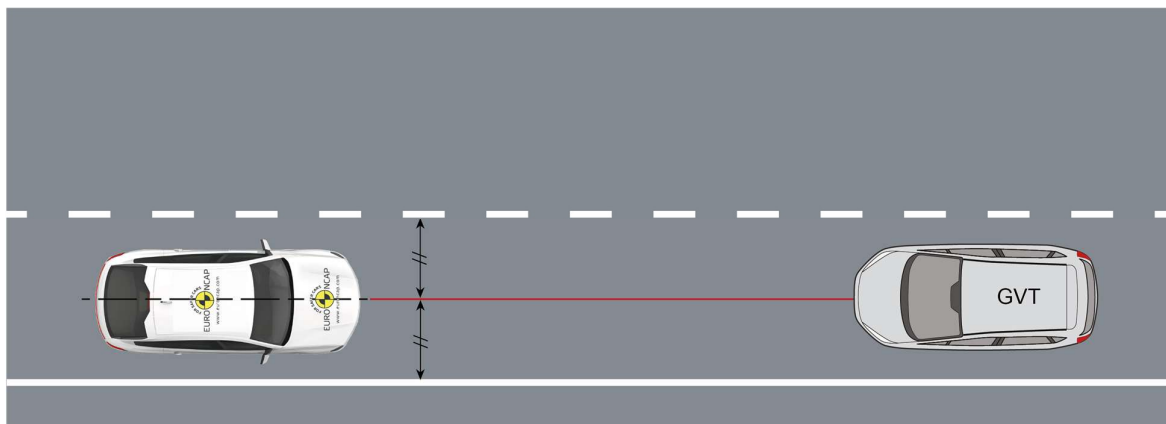

Figure 3-1 CCFhos

CCFhol	GVT speed	Impact Location			
		100%	75%	50%	25%
30 km/h	50 km/h				
40 km/h	50 km/h				
50 km/h	50 km/h				
60 km/h	70 km/h				
70 km/h	70 km/h				
80 km/h	70 km/h				
90 km/h	90 km/h				
100 km/h	100 km/h				

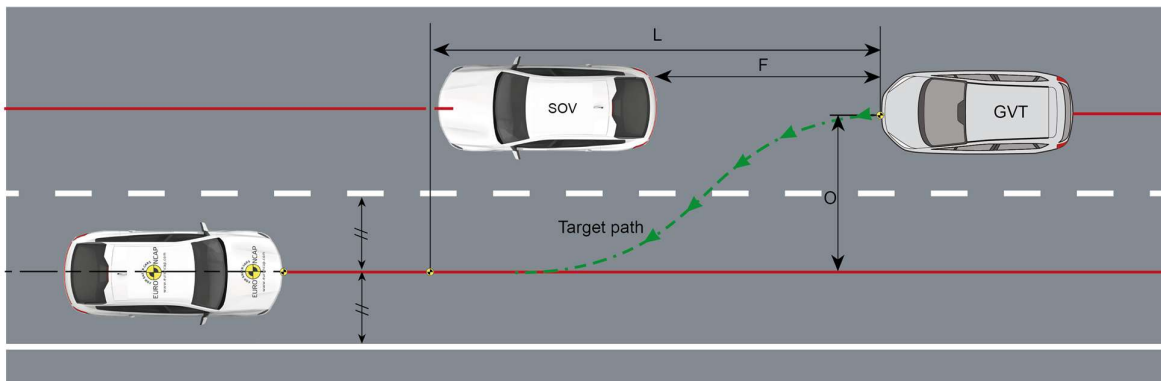

Figure 3-2 CCFhol

Detailed scenario parametrization in CCFhol for all VUT and Target speed combinations will be made available upon request to the ANCAP Secretariat.

Below table indicates the parameters of test cases where the VUT and Target travel at the same speed, and with a 50% impact location (full overlap). When impact location is different than 50%, the initial lateral position of SOV and GVT shall be altered so that a 3.5m lane change offset (parameter O) results in the targeted impact location.

GVT & SOV speed	Lane change offset (O)	Curvature (1/m)	Lane change length (L)	Following Distance (F)	TTC at end of lane change	Max Lateral acceleration
50 km/h	3.5 m	0.0076	44 m	[13.9] m	[1.5] s	1.50 m/s ²
70 km/h	3.5 m	0.0039	60 m	[19.4] m	[1.5] s	1.50 m/s ²
90 km/h	3.5 m	0.0023	78 m	[25.0] m	[1.5] s	1.50 m/s ²

GVT & SOV speed	Lane change offset (O)	Curvature (1/m)	Lane change length (L)	Following Distance (F)	TTC at end of lane change	Max Lateral acceleration
100 km/h	3.5 m	0.0019	88 m	[27.8] m	[1.5] s	1.50 m/s ²

3.1.1.3 Car-to-Motorcyclist Rear

CMRs	EMT speed	Function	Impact Location				
			90%	75%	50%	25%	10%
10 km/h	0 km/h	AEB					
20 km/h	0 km/h	AEB					
30 km/h	0 km/h	AEB					
40 km/h	0 km/h	AEB					
50 km/h	0 km/h	AEB					
60 km/h	0 km/h	FCW					
70 km/h	0 km/h	FCW					
80 km/h	0 km/h	FCW					

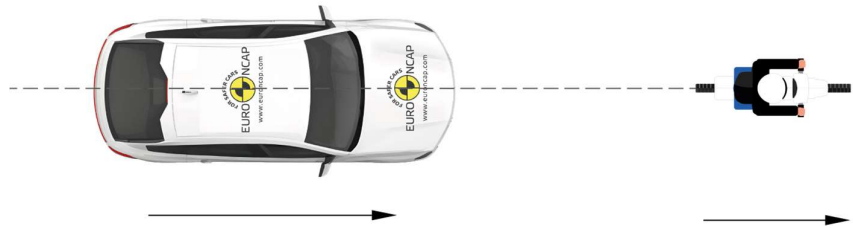

Figure 3-3 CMRs scenario, representing the 50% impact location

The Vehicle Manufacturer shall inform ANCAP whether the FCW cases are to be verified with FCW or AEB. Where the AEB system is able to avoid the collision in the FCW cases, the points are automatically awarded for the corresponding FCW test. If AEB avoids impact, FCW points are awarded automatically.

CMRb	EMT Speed	Function	Impact Location				
			90%	75%	50%	25%	10%
30 km/h	30 km/h	AEB					
40 km/h	40 km/h	AEB					
50 km/h	50 km/h	AEB					
60 km/h	60 km/h	AEB					
70 km/h	70 km/h	AEB					
80 km/h	80 km/h	AEB					

90 km/h	90 km/h	AEB					
100 km/h	100 km/h	AEB					
110 km/h	110 km/h	AEB					
120 km/h	120 km/h	AEB					
130 km/h	130 km/h	AEB					

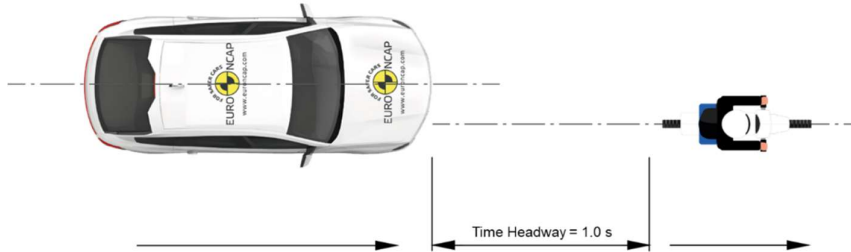

Figure 3-4 CMRb scenario, representing the 25% impact location

For CMRb, the Time Headway = 1.0 s, and the target acceleration = -4m/s^2 for both Standard Range and Extended range. The desired deceleration of the EMT shall be reached within 1.0 second ($T_0 + 2.0\text{s}$) which after the EMT shall remain within $\pm 0.5 \text{ km/h}$ of the reference speed profile, derived from the desired deceleration, until the vehicle speed equals 2km/h .

3.1.2 Turning

Turning	Standard	Extended	Robustness Layer	Total
Car-to-Car Front TAP	4.0	0.5	0.5	5.0
Car-to-Motorcycle Front TAP	4.0	0.5	0.5	5.0

3.1.2.1 Car-to-Car Front Turn Across Path

CCFtap	GVT speed			
	30 km/h	45 km/h	60 km/h	80 km/h
10 km/h				
15 km/h				
20 km/h				
25 km/h				

For the CCFtap scenario, for the VUT assume an initial straight-line path followed by a turn (clothoid, fixed radius and clothoid as specified in section 0), followed again by a straight line, hereby known as the test path. The direction indicator is applied at $1.0\text{s} \pm 0.5\text{s}$ before T_{steer} .

The GVT will follow a straight-line path in the lane adjacent to the VUT's initial position, in the opposite direction to the VUT. The straight-line path of the VUT and GVT will be 1.75m from the centre of the centre dashed lane marking of the VUT lane.

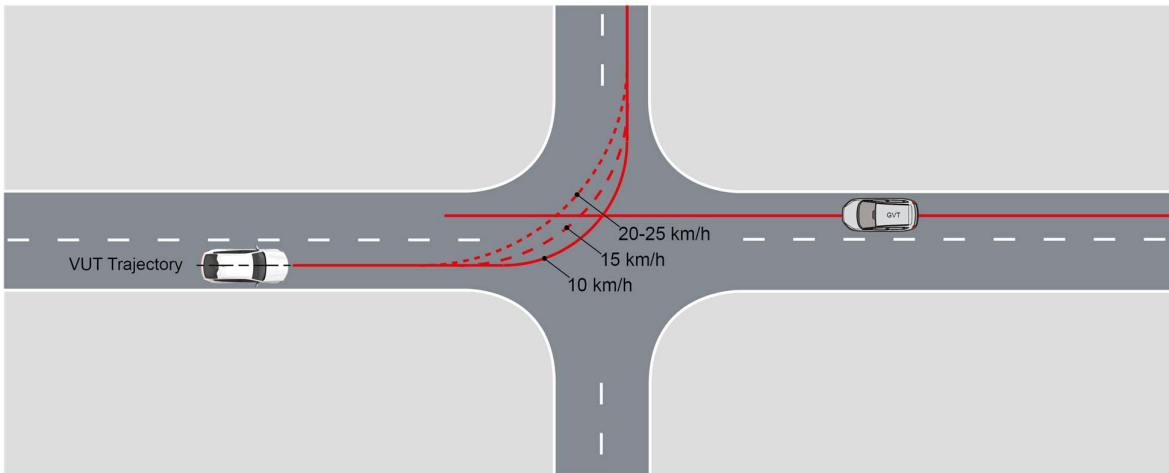

Figure 3-5 CCFtap scenario VUT and GVT paths

The paths of the VUT and target vehicle will be synchronised so that the front edges of the target meets the 50% impact location (assuming no system reaction) of the width of the VUT. The VUT longitudinal path error shall be within $\pm [1.0]$ m when determined in accordance with section 0.

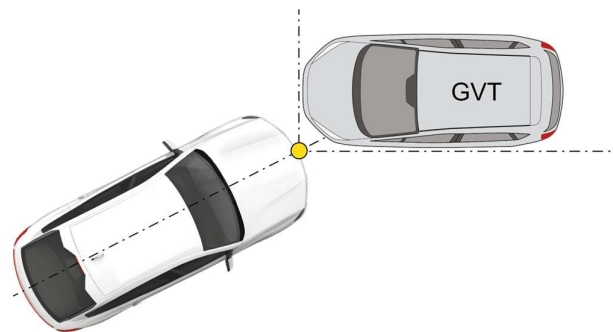

Figure 3-6 CCFtap impact location definition

3.1.2.2 Car-to-Motorcyclist Front Turn Across Path

CMFtap	EMT speed			
	30 km/h	45 km/h	60 km/h	80 km/h
10 km/h				
15 km/h				
20 km/h				

25 km/h				
---------	--	--	--	--

For the CMFtap scenario, for the VUT assume an initial straight-line path followed by a turn (clothoid, fixed radius and clothoid as specified in section 0), followed again by a straight line, hereby known as the test path. The direction indicator is applied at $1.0s \pm 0.5s$ before T_{steer} .

The EMT will follow a straight-line path in the lane adjacent to the VUT's initial position, in the opposite direction to the VUT. The straight-line path of the VUT and target will be 1.75m from the centre of the centre dashed lane marking of the VUT lane.

The paths of the VUT and EMT will be synchronised so that the front wheel of the target meets the 50% impact location (assuming no system reaction) of the width of the VUT. The VUT longitudinal path error shall be within $\pm [1.0]$ m when determined in accordance with section 0

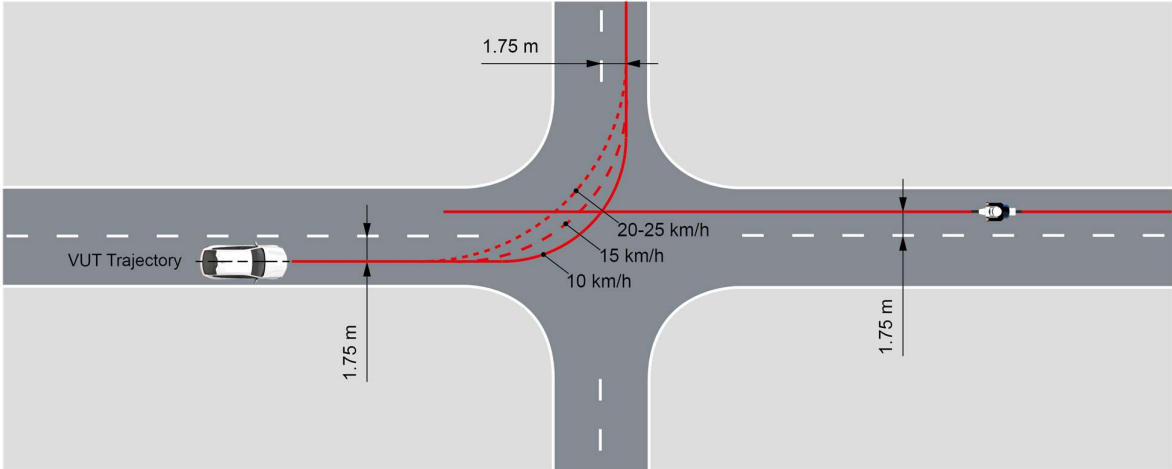

Figure 3-7 CMFtap scenario VUT and EMT paths

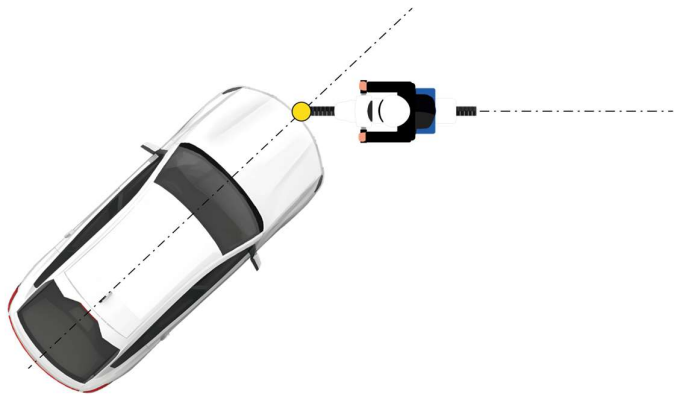

Figure 3-8 CMFtap impact location definition

3.1.3 Crossing

Crossing	Standard	Extended	Robustness Layer	Total
Car-to-Car	6	0.75	0.75	7.5
Car-to-Motorcycle	6	0.75	0.75	7.5

3.1.3.1 Car-to-Car Crossing

CCCscp	Function	GVT speed						
		20 km/h	30 km/h	40 km/h	50 km/h	60 km/h	70 km/h	80 km/h
20 km/h	AEB							
30 km/h	AEB							
40 km/h	AEB						N/A	N/A
50 km/h	AEB						N/A	N/A
60 km/h	AEB						N/A	N/A
70 km/h	AEB			N/A	N/A	N/A	N/A	N/A
80 km/h	AEB			N/A	N/A	N/A	N/A	N/A

For the VUT assume a straight-line path equivalent to the centre line of the driving lane, approaching and continuing straight ahead across a junction.

For the GVT assume a straight-line path equivalent to the centre line of the driving lane, perpendicular to that of the VUT, travelling across the junction from either the nearside or farside direction, randomly selected by the test laboratory.

To achieve the correct GVT speed, the GVT must be accelerated at a rate $>1\text{m/s}^2$ during the acceleration phase. This is followed by a 0.5s stabilization phase, after which steady state conditions must be met as soon as the GVT has arrived in the field of vision of the VUT, corresponding to [3.5]s TTC.

The paths will be synchronised to that (assuming no system reaction) the reference point of the GVT collides with 50% impact location of the VUT, for both Standard and Extended Range, as indicated in Figure 3-10. The boundary condition for synchronization is a VUT Time Error of $\pm[0.1]\text{s}$.

The obscuration (only applicable to Standard Range) is formed by 3 vehicles parked in parallel at either side along the VUT trajectory (parked either at the farside when target approaches from the farside, or nearside when target approaches from the nearside).

The group of 3 obscuration vehicles are parked 1m apart. For , and at a lateral offset of 2m for nearside target approach and 5.5m for farside target approach, from the edge of the parked vehicles to the VUT trajectory, where:

- Front obscuration vehicle (closest to target trajectory) is of type “larger obscuration vehicle” as per APPENDIX B
- Second obscuration vehicle is of type “smaller obscuration vehicle” as per APPENDIX B
- Third obscuration vehicle can be any type of passenger vehicle
- Third obscuration vehicle can be any type of passenger vehicle

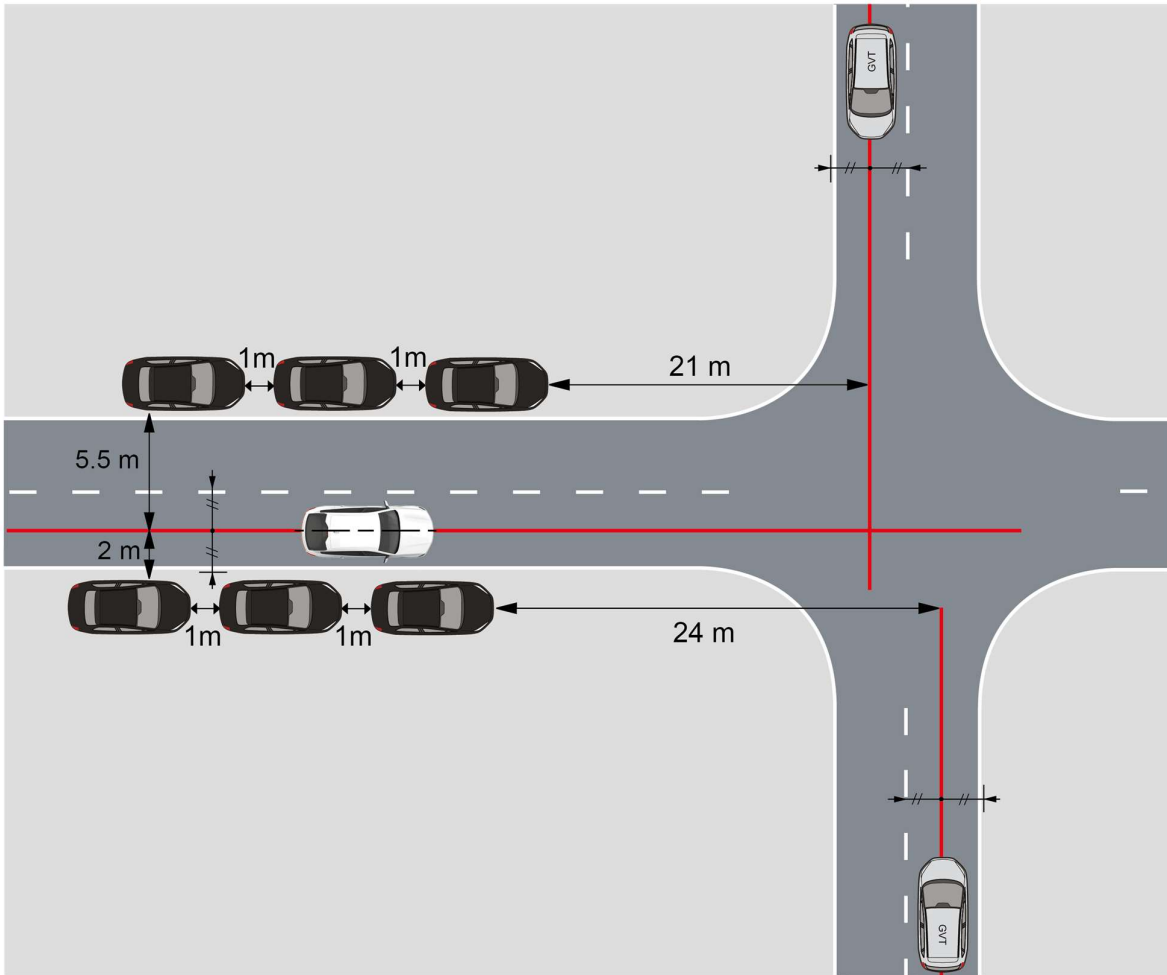

Figure 3-9 CCCscp, obstructed

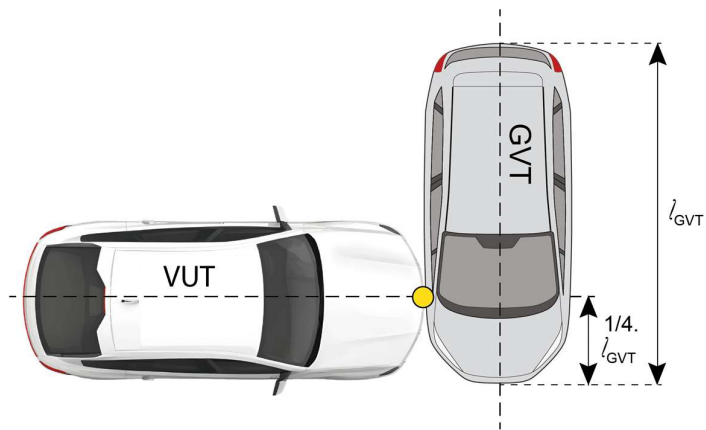

Figure 3-10 Impact location on CCCscp

3.1.3.2 Car-to-Motorcyclist Crossing

CMCscp	Function	EMT speed						
		20 km/h	30 km/h	40 km/h	50 km/h	60 km/h	70 km/h	80 km/h
20 km/h	AEB							
30 km/h	AEB							
40 km/h	AEB						N/A	N/A
50 km/h	AEB						N/A	N/A
60 km/h	AEB						N/A	N/A
70 km/h	AEB			N/A	N/A	N/A	N/A	N/A
80 km/h	AEB			N/A	N/A	N/A	N/A	N/A

For the VUT assume a straight-line path equivalent to the centre line of the driving lane, approaching and continuing straight ahead across a junction.

For the EMT, assume a straight-line path equivalent to the centre line of the driving lane, perpendicular to that of the VUT, travelling across the junction from either the nearside or farside direction, randomly selected by the test laboratory

To achieve the correct EMT speed, the EMT must be accelerated at a rate $>1\text{m/s}^2$ during the acceleration phase. This is followed by a 0.5s stabilization phase, after which steady state conditions must be met as soon as the EMT has arrived in the field of vision of the VUT, corresponding to [3.5]s TTC.

The paths will be synchronised to that (assuming no system reaction) the reference point of the EMT collides with 90% side impact location (EMT approaching from both nearside and farside), for both Standard and Extended Range, as indicated in Figure 3-12. The boundary condition for synchronization is a VUT Time Error of $\pm[0.1]\text{s}$.

The obscuration (only applicable to Standard Range) is formed by 3 vehicles parked in parallel at either side along the VUT trajectory (parked either at the farside when target approaches from the farside, or nearside when target approaches from the nearside).

The group of 3 obscuration vehicles are parked 1m apart. For , and at a lateral offset of 2m for nearside target approach and 5.5m for farside target approach, from the edge of the parked vehicles to the VUT trajectory, where:

- Front obscuration vehicle (closest to target trajectory) is of type “larger obscuration vehicle” as per APPENDIX B
- Second obscuration vehicle is of type “smaller obscuration vehicle” as per APPENDIX B
- Third obscuration vehicle can be any type of passenger vehicle

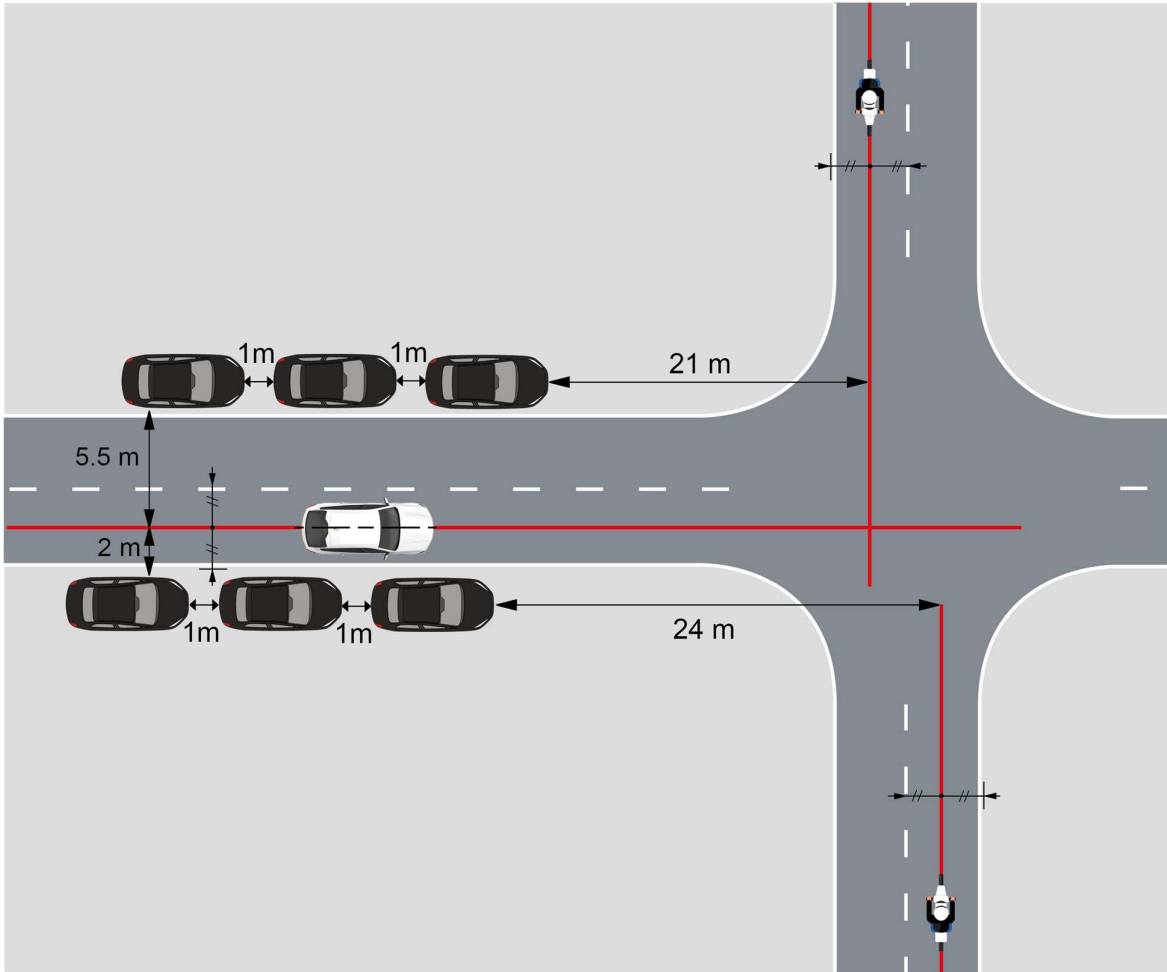

Figure 3-11 CMCscp, obstructed

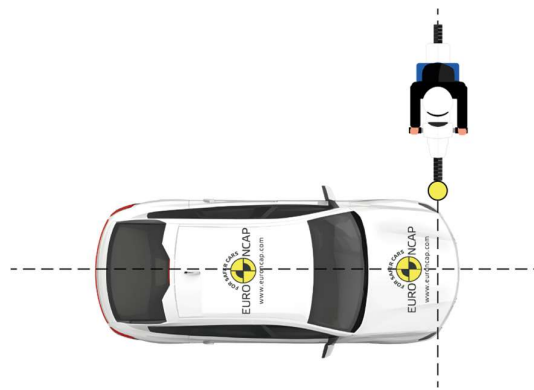

Figure 3-12 90% Impact location on CMCscp (target approaching from farside)

3.2 Pedestrian & Cyclist Scenarios

Pedestrian & Cyclist		Standard	Extended	Robustness	Total
Longitudinal	Car-to-Pedestrian	2.0	0.25	0.25	5.0
	Car-to-Bicyclist	2.0	0.25	0.25	
Turning	Car-to-Pedestrian	2.0	0.25	0.25	5.0
	Car-to-Bicyclist	2.0	0.25	0.25	
Crossing	Car-to-Pedestrian	4.0	0.5	0.5	10.0
	Car-to-Bicyclist	4.0	0.5	0.5	

3.2.1 Longitudinal

Longitudinal	Standard	Extended	Robustness	Total
Car-to-Pedestrian	2.0	0.25	0.25	2.5
Car-to-Bicyclist	2.0	0.25	0.25	2.5

3.2.1.1 Car-to-Pedestrian Longitudinal

CPLA	EPT speed	Function	*/C	Impact Location			
				10%	25%	50%	75%
10 km/h	5 km/h	AEB	*				
20 km/h	5 km/h	AEB	*				
30 km/h	5 km/h	AEB	*				
40 km/h	5 km/h	AEB	*				
50 km/h	5 km/h	AEB	*				
60 km/h	5 km/h	AEB	*				
<hr/>							
50 km/h	5 km/h	FCW	*				
60 km/h	5 km/h	FCW	*				
70 km/h	5 km/h	FCW	*				
80 km/h	5 km/h	FCW	*				
<hr/>							
10 km/h	5 km/h	AEB	C				
20 km/h	5 km/h	AEB	C				
30 km/h	5 km/h	AEB	C				
40 km/h	5 km/h	AEB	C				
50 km/h	5 km/h	AEB	C				
60 km/h	5 km/h	AEB	C				
<hr/>							
50 km/h	5 km/h	FCW	C				
60 km/h	5 km/h	FCW	C				
70 km/h	5 km/h	FCW	C				

For nighttime tests in CPLA (marked with Ⓒ), illumination conditions shall apply as described in Euro NCAP Technical Bulletin CA 101. Furthermore, nighttime tests shall be conducted with low beams, unless the vehicle is equipped with automated high beam as standard (in which case, tests shall be executed with high beams).

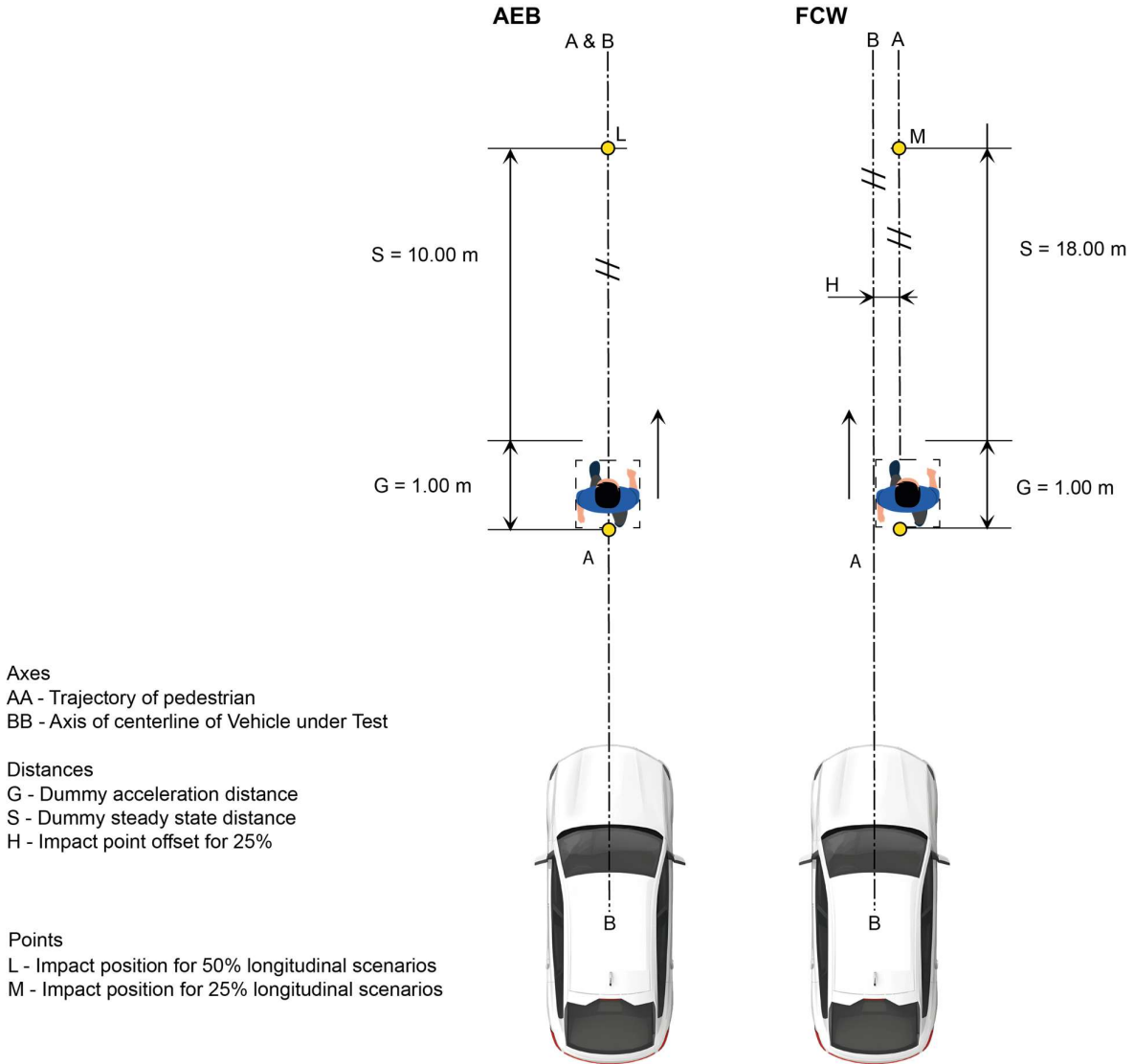

Figure 3-13 CPLA scenario, Longitudinal walking Adult

3.2.1.2 Car-to-Bicyclist Longitudinal

CBLA	EBT speed	Function	Impact Location			
			10%	25%	50%	75%
20 km/h	15 km/h	AEB				
30 km/h	15 km/h	AEB				
40 km/h	15 km/h	AEB				
50 km/h	15 km/h	AEB				
60 km/h	15 km/h	AEB				
50 km/h	20 km/h	FCW				
60 km/h	20 km/h	FCW				
70 km/h	20 km/h	FCW				
80 km/h	20 km/h	FCW				

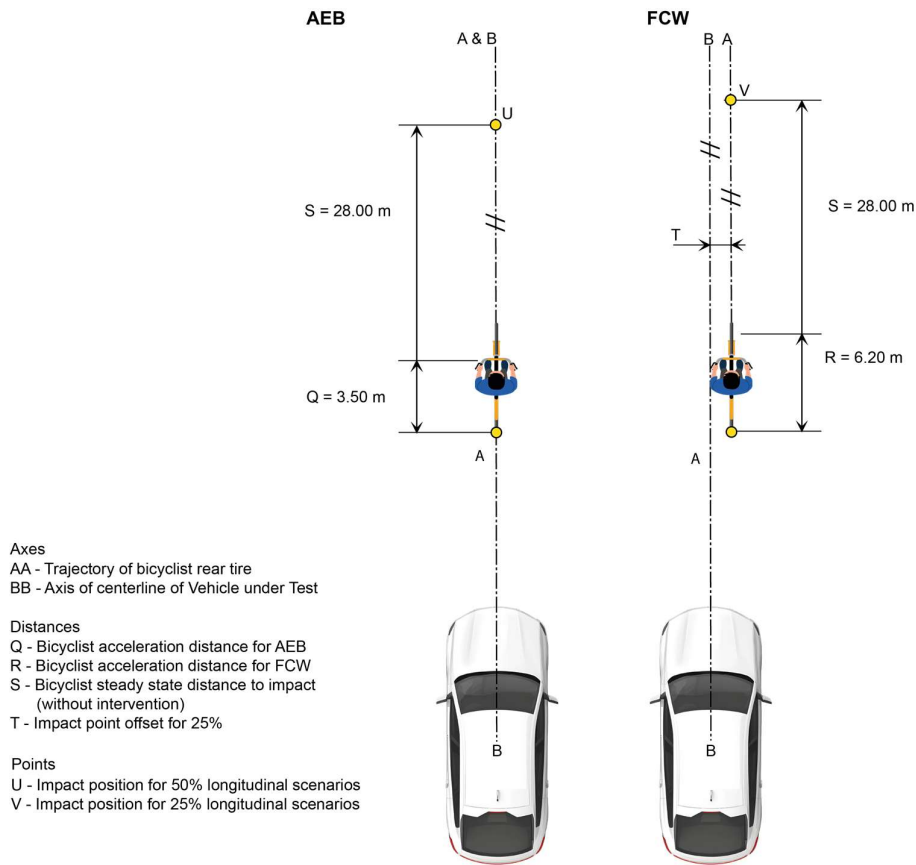

Figure 3-14 CBLA scenarios, Longitudinal Bicyclist (AEB left & FCW right)

Note: the reflected acceleration distances *Q* and *R* are meant to suit the limited usable length of a belt-driven carrier platform. If a self-propelled carrier platform is used for the execution of CBLA, the acceleration distances *Q* and *R* can be increased according to the acceleration capabilities of the platform carrier.

3.2.2 Turning

Turning	Standard	Extended	Robustness	Total
Car-to-Pedestrian	2.0	0.25	0.25	2.5
<i>CPTAfs & CPTAns</i>	<i>1.0</i>	<i>0.125</i>	<i>0.125</i>	
<i>CPTAfo & CPTAno</i>	<i>1.0</i>	<i>0.125</i>	<i>0.125</i>	
Car-to-Bicyclist	2.0	0.25	0.25	2.5
<i>CBTAfs & CBTAns</i>	<i>1.0</i>	<i>0.125</i>	<i>0.125</i>	
<i>CBTAfo & CBTAno</i>	<i>1.0</i>	<i>0.125</i>	<i>0.125</i>	

3.2.2.1 Car-to-Pedestrian Turning

The CPTA scenario consists of 4 sub-scenarios

- CPTAfs: Farside turn, target travelling in the same direction
- CPTAfo: Farside turn, target travelling in the opposite direction
- CPTAns: Nearside turn, target travelling in the same direction
- CPTAno: Nearside turn, target travelling in the opposite direction

The 25 km/h turn as part of the Extended Range is conducted in the 20 km/h path.

CPTAfs	Turn	EPT Direction	EPT Speed	Impact Location				
				10%	25%	50%	75%	90%
10 km/h	Farside	Same	5 km/h					
15 km/h	Farside	Same	5 km/h					
20 km/h	Farside	Same	5 km/h					
25 km/h	Farside	Same	5 km/h					

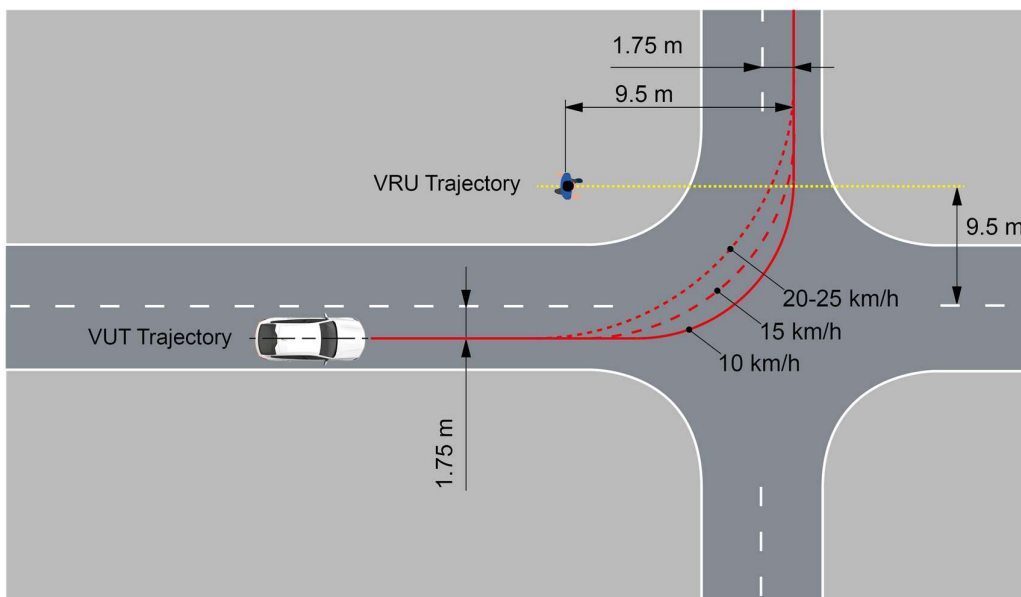

Figure 3-15 CPTAfs scenario – VUT left turn, pedestrian crossing from farside

CPTAfo	Turn	EPT Direction	EPT Speed	Impact Location				
				10%	25%	50%	75%	90%
10 km/h	Farside	Opposite	5 km/h					
15 km/h	Farside	Opposite	5 km/h					
20 km/h	Farside	Opposite	5 km/h					
25 km/h	Farside	Opposite	5 km/h					

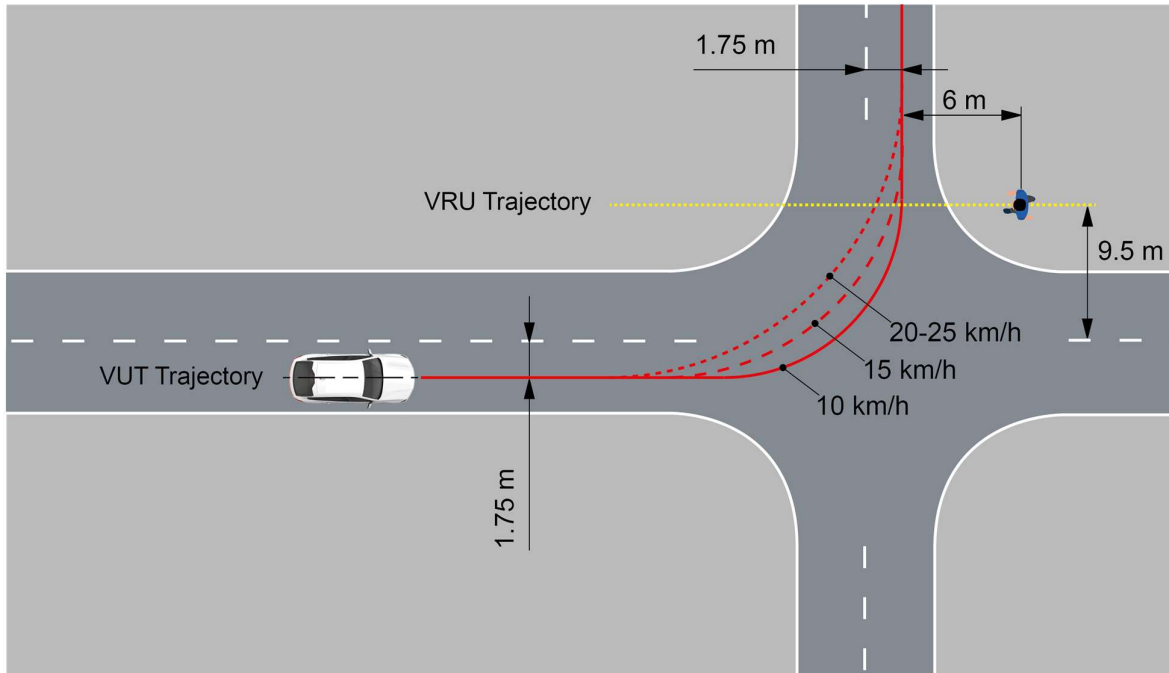

Figure 3-16 CPTAfo scenario – VUT left turn, pedestrian crossing from nearside

CPTAno	Turn	EPT Direction	EPT Speed	Impact Location				
				10%	25%	50%	75%	90%
10 km/h	Nearside	Opposite	5 km/h					

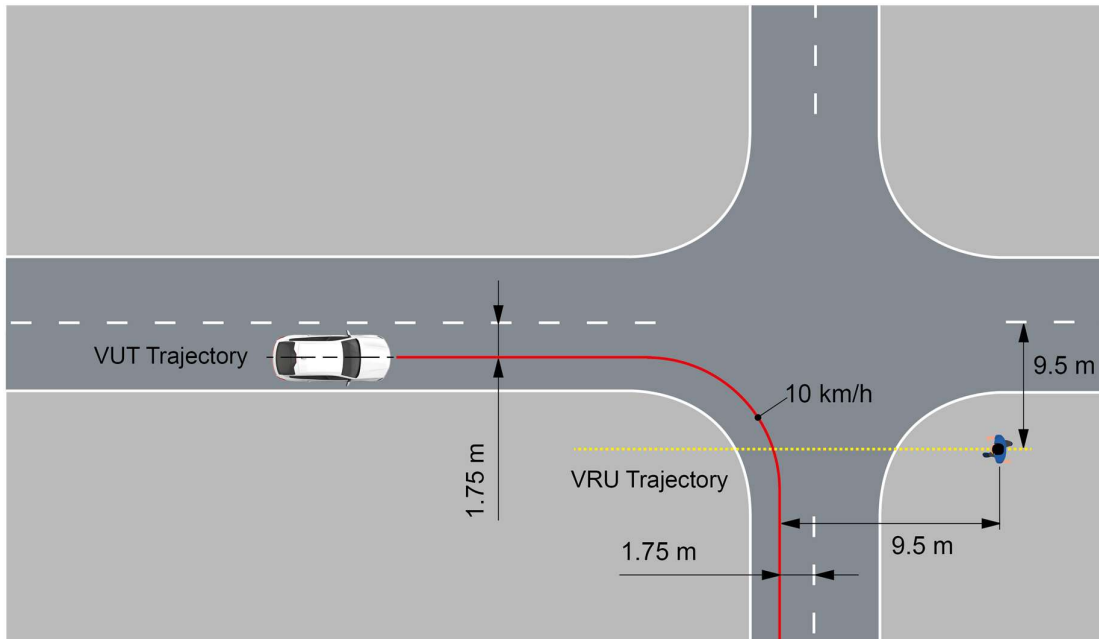

Figure 3-17 CPTAno scenario – VUT right turn, pedestrian crossing from farside

CPTAns	Turn	EPT Direction	EPT Speed	Impact Location				
				10%	25%	50%	75%	90%
10 km/h	Nearside	Same	5 km/h					

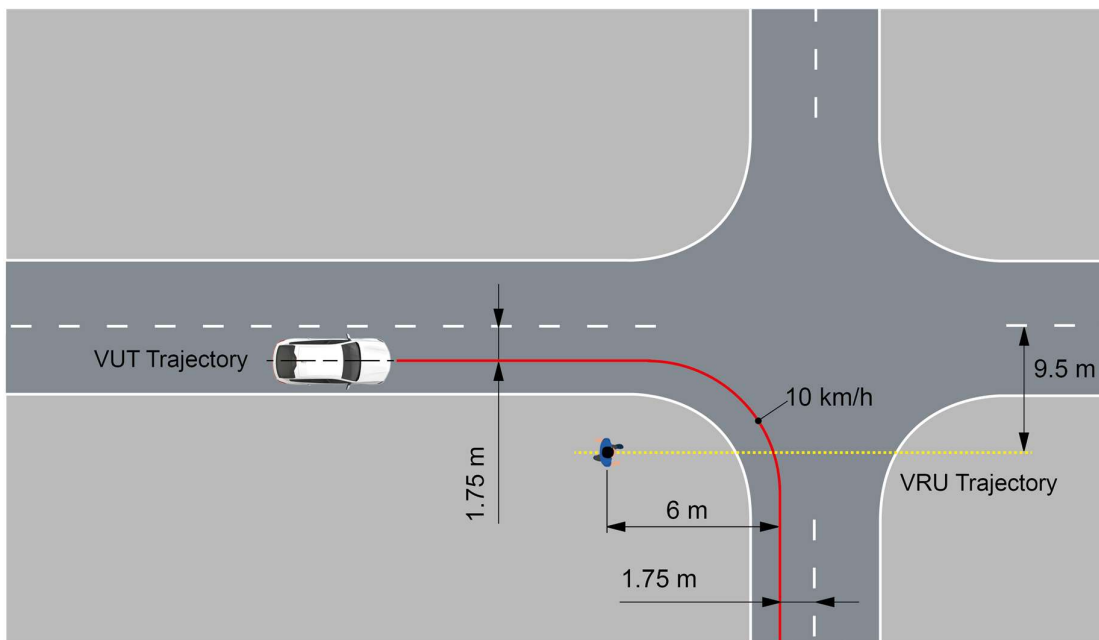

Figure 3-18 CPTAns scenario – VUT right turn, pedestrian crossing from nearside

3.2.2.2 Car-to-Bicyclist Turning

The CBTA scenario consists of 4 sub-scenarios

- CBTAfs: Farside turn, target travelling in the same direction
- CBTAfo: Farside turn, target travelling in the opposite direction
- CBTAns: Nearside turn, target travelling in the same direction
- CBTAno: Nearside turn, target travelling in the opposite direction

In all cases, the target speed is 15 km/h and the target reference point is on the front wheel.

The 25 km/h turn as part of the Extended Range is conducted in the 20 km/h path (where applicable).

CBTAfs	Turn	EBT Direction	EBT Speed	Impact Location	
				100%	75% (side)
10 km/h	Farside	Same	15 km/h		
15 km/h	Farside	Same	15 km/h		
20 km/h	Farside	Same	15 km/h		
25 km/h	Farside	Same	15 km/h		

CBTAfo	Turn	EBT Direction	EBT Speed	Impact Location				
				10%	25%	50%	75%	90%
10 km/h	Farside	Opposite	15 km/h					
15 km/h	Farside	Opposite	15 km/h					
20 km/h	Farside	Opposite	15 km/h					
25 km/h	Farside	Opposite	15 km/h					

CBTAns	Turn	EBT Direction	EBT Speed	Impact Location	
				75% (side)	0%
10 km/h	Nearside	Same	15 km/h		

CBTAno	Turn	EBT Direction	EBT Speed	Impact Location		
				25%	50%	75%
10 km/h	Nearside	Opposite	15 km/h			

For the CBTA scenarios, for the VUT assume an initial straight-line path followed by a turn (clothoid, fixed radius and clothoid as specified in section 0), followed again by a straight line, hereby known as the test path. The direction indicator is applied at $1.0s \pm 0.5s$ before T_{steer} .

The VUT will follow a straight-line path in the lane adjacent to the VUT's initial position, in the opposite direction to the VUT. The straight-line path of the VUT and GVT will be 1.75m from the centre of the centre dashed lane marking of the VUT lane.

The VUT will follow a straight-line path in the approach lane which will be 1.75m from the centre of the centre dashed lane marking of the VUT lane. The EBT will follow a straight-line path which will be respectively 2.75m (CBTAfo) and 5.00m (CBTAfs, CBTAns, CBTAno) from the centre of the centre dashed lane marking of the VUT lane. Steady state speed of EBT starts at 4sec TTC.

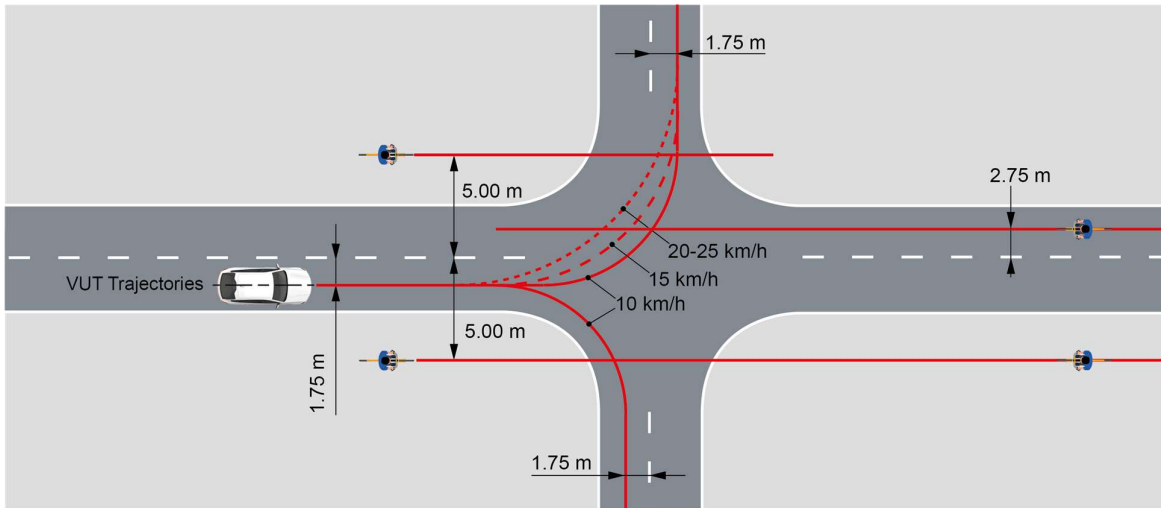

Figure 3-19 CBTA scenario

3.2.3 Crossing

Crossing	Standard	Extended	Robustness	Total
Car-to-Pedestrian	CPNA	1.0	0.125	5.0
	CPFA	1.0	0.125	
	CPNCO	2.0	0.25	
Car-to-Bicyclist	CBNA	1.0	0.125	5.0
	CBFA	1.0	0.125	
	CBNAO	2.0	0.25	

3.2.3.1 Car-to-Pedestrian Crossing

CPNA	EPT Speed	*/C	Impact Location				
			10%	25%	50%	75%	90%
10 km/h	5 km/h	*					
20 km/h	5 km/h	*					
30 km/h	5 km/h	*					
40 km/h	5 km/h	*					
50 km/h	5 km/h	*					
60 km/h	5 km/h	*					
<hr/>							
10 km/h	5 km/h	C					
20 km/h	5 km/h	C					
30 km/h	5 km/h	C					
40 km/h	5 km/h	C					
50 km/h	5 km/h	C					
60 km/h	5 km/h	C					

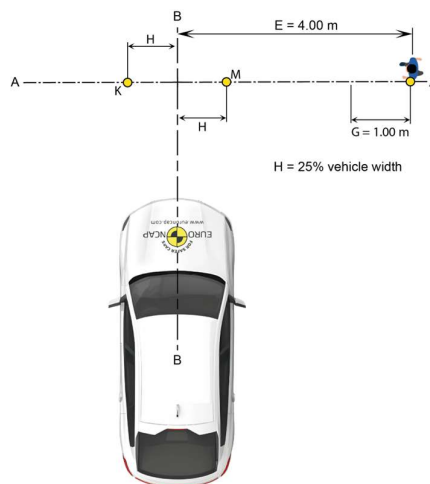

Figure 3-20 CPNA-25 & CPNA-75 scenarios, Walking Adult from Nearside

CPFA	EPT Speed	*/C	Impact Location				
			10%	25%	50%	75%	90%
10 km/h	8 km/h	*					
20 km/h	8 km/h	*					
30 km/h	8 km/h	*					
40 km/h	8 km/h	*					
50 km/h	8 km/h	*					
60 km/h	8 km/h	*					
10 km/h	8 km/h	C					
20 km/h	8 km/h	C					
30 km/h	8 km/h	C					
40 km/h	8 km/h	C					
50 km/h	8 km/h	C					
60 km/h	8 km/h	C					

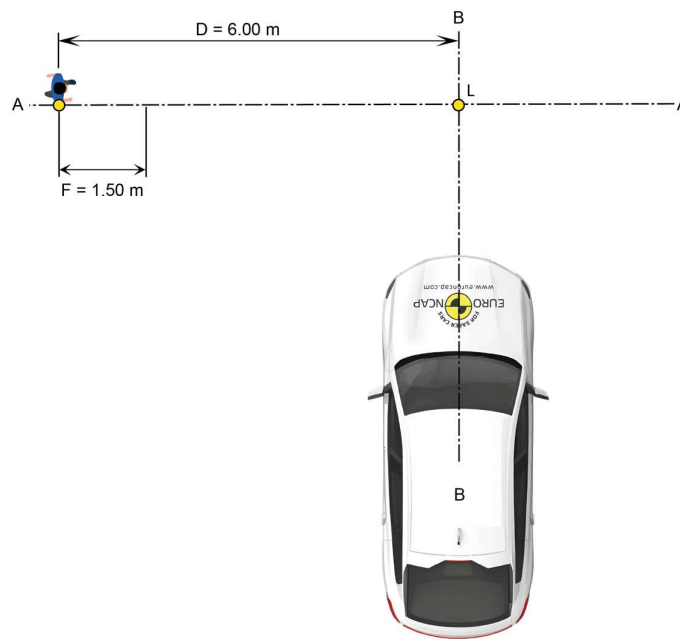

Figure 3-21 CPFA-50 scenario, Adult running from Farside

CPNCO	EPTc Speed	*/C	Impact Location		
			25%	50%	75%
10 km/h	5 km/h	*			
20 km/h	5 km/h	*			
30 km/h	5 km/h	*			
40 km/h	5 km/h	*			
50 km/h	5 km/h	*			
60 km/h	5 km/h	*			
10 km/h	5 km/h	C			
20 km/h	5 km/h	C			
30 km/h	5 km/h	C			
40 km/h	5 km/h	C			
50 km/h	5 km/h	C			
60 km/h	5 km/h	C			

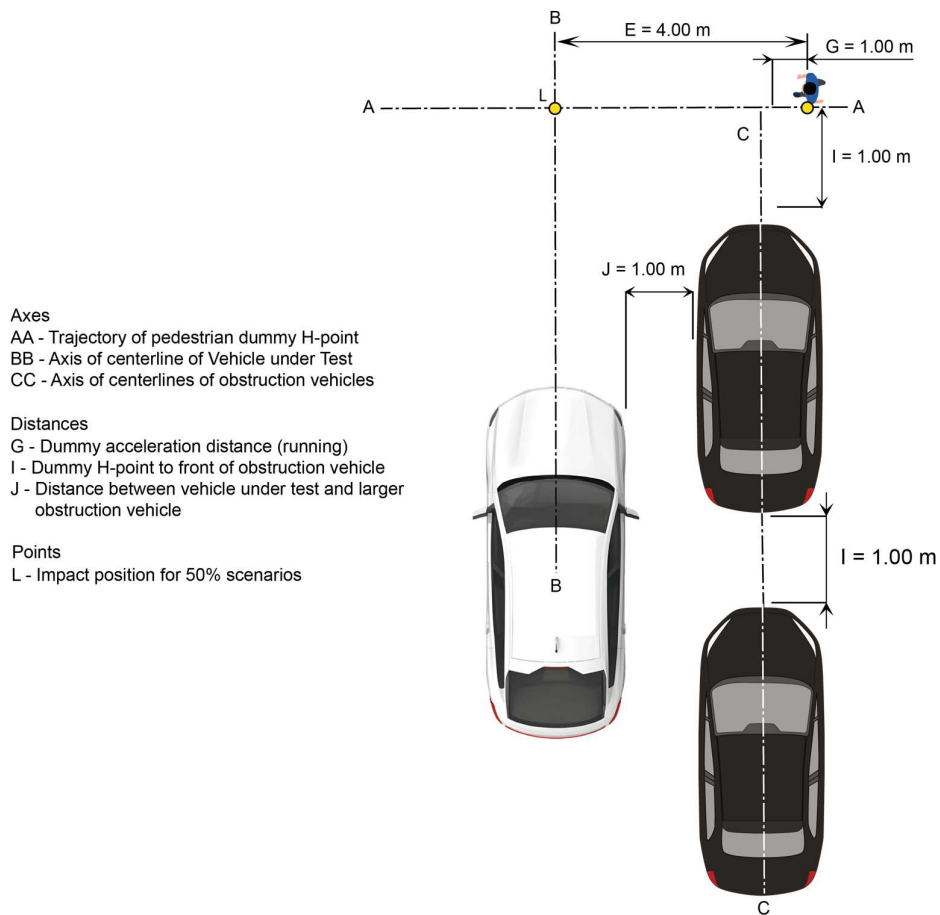

Figure 3-22 CPNCO-50 scenario, Running Child from Nearside from Obstruction (Annex B)

3.2.3.2 Car-to-Bicyclist Crossing

CBNA	EBT Speed	Impact Location				
		10%	25%	50%	75%	90%
10 km/h	15 km/h					
20 km/h	15 km/h					
30 km/h	15 km/h					
40 km/h	15 km/h					
50 km/h	15 km/h					
60 km/h	15 km/h					

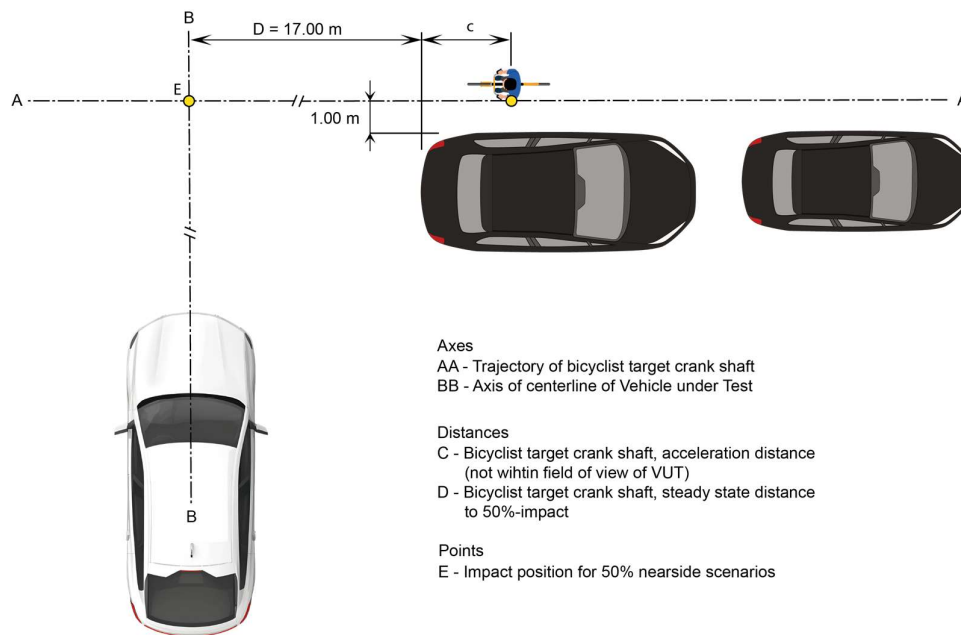

Figure 3-23 CBNA scenario, Bicyclist from Nearside

Notes: the gap between the obscuration vehicles should be [0.1 ~ 0.3] m.

CBNAO	EBT Speed	Impact Location				
		10%	25%	50%	75%	90%
10 km/h	10 km/h					
20 km/h	10 km/h					
30 km/h	10 km/h					
40 km/h	10 km/h					
50 km/h	10 km/h					
60 km/h	10 km/h					

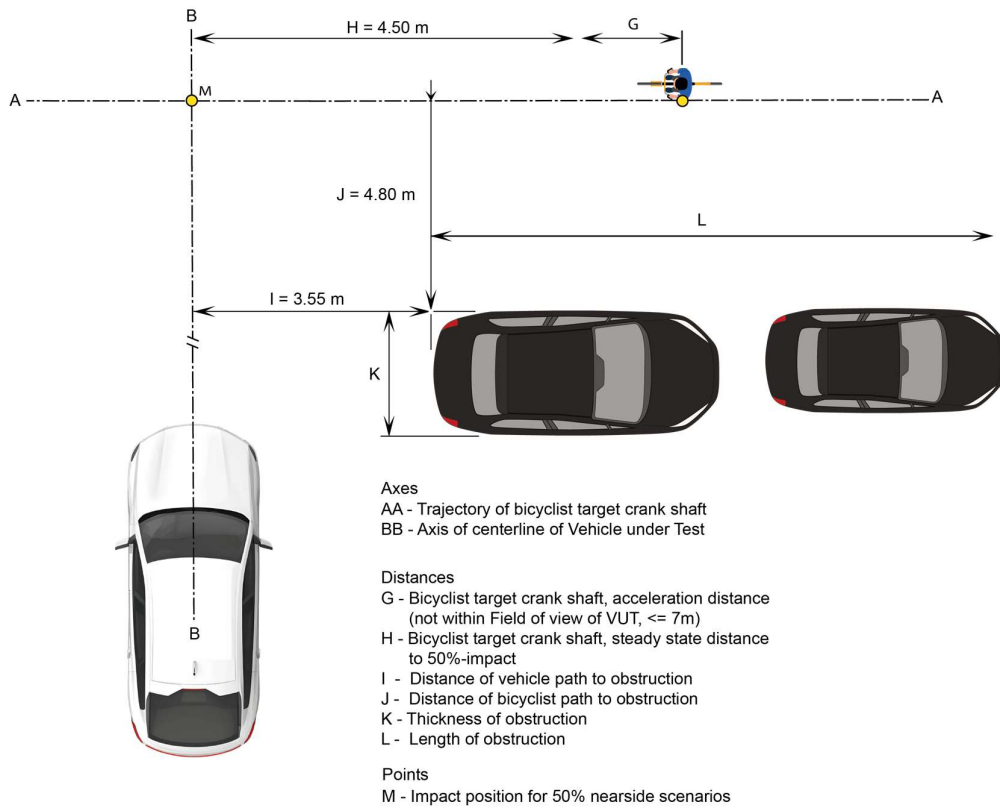

Figure 3-24 CBNAO scenario, Bicyclist from Nearside (obstructed)

Notes: the gap between the obscuration vehicles should be [0.1 ~ 0.3] m.

CBFA	EBT Speed	Impact Location				
		10%	25%	50%	75%	90%
10 km/h	20 km/h					
20 km/h	20 km/h					
30 km/h	20 km/h					
40 km/h	20 km/h					
50 km/h	20 km/h					
60 km/h	20 km/h					

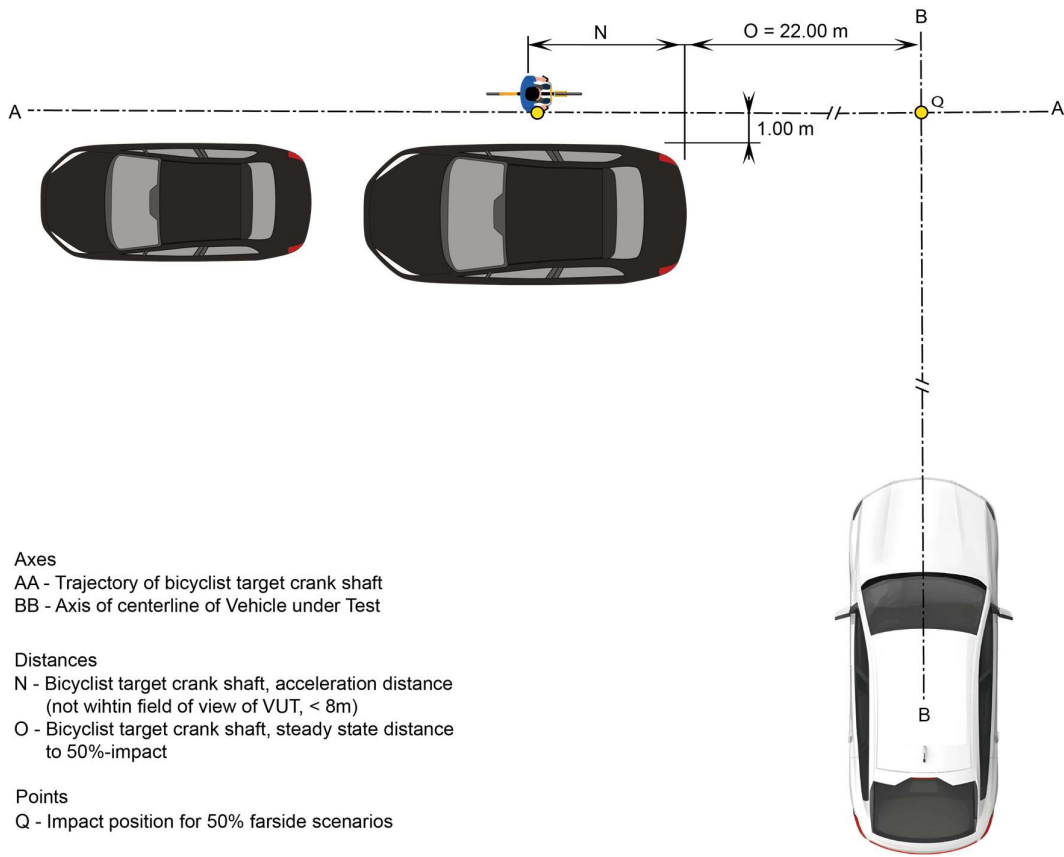

Figure 3-25 CBFA scenario, Bicyclist from Farside

Notes: the gap between the obscuration vehicles should be [0.1 ~ 0.3] m.

4 TEST EXECUTION

4.1 Performance Predictions

The Vehicle Manufacturer shall provide the ANCAP with data detailing the predicted performance of the AEB/FCW system in each of the grid cells for all test scenarios and in accordance with the assessment criteria outlined in 5.2.

The predicted performance will be used as a reference to verify performance using randomly selected verification tests. Performance predictions may be provided in either of the following formats:

Performance Predictions		Virtual Testing	Self-claim	Field Data	System overriding conditions
Standard Range		✓	✓		
Extended Range		✓	✓		
Robustness Layers	Decision & Control	✓	✓		✓*
	Perception			✓	

* *Applicable only for the 'Driver input pre-crash' robustness layer.*

The information shall be supplied by the manufacturer before any testing begins, preferably with delivery of the test vehicle(s).

In case a Vehicle Manufacturer does not supply any prediction data, the test laboratory shall a smart testing approach.

4.1.1 Virtual Testing

Virtual Testing refers to as simulation-based performance predictions, following the provisions outlined in ANCAP VTA Protocol.

4.1.2 Self-claim

Self-claimed refers to as colour data provided by the Vehicle Manufacturer where no further evidence is required.

4.1.3 Field Data

Where Field Data is required, the Vehicle Manufacturer shall demonstrate function availability and/or specific performance under the presence of perception-related robustness layers, by means of insights gathered in real-world driving conditions. This is to be reported according to the provisions outlined in Euro NCAP Technical Bulletin CA 003.

4.1.4 System overriding conditions

This information is only required from the Vehicle Manufacturer for the robustness layer "Driver Input pre-crash", as part of the necessary evidence to award points. This information shall contain, but not be limited to, conditions leading to the system override e.g., steering wheel angle/speed, acceleration pedal percentage/rate, driver state link, etc.

4.2 Verification tests

The verification tests are randomly selected grid cells, distributed in line with the Vehicle Manufacturer prediction (excluding red grid cells), and covering Standard Range, Extended Range and Robustness Layers.

For each scenario, the following random selection of Verification Tests is made by ANCAP and executed by the test laboratory:

4.2.1 Standard Range

For Standard Range, a random selection of 3 to 5 verification tests is done per scenario, as indicated below:

Car & PTW	Scenario		Verification tests
Longitudinal	Car-to-Car Rear	CCRs	3
		CCRm	3
		CCRb	3
	Car-to-Car Front	CCFhos	4
		CCFhol	4
	Car-to-Motorcycle Rear	CMRs	3
CMRb		3	
Turning	Car-to-Car TAP	CCFtap	3
	Car-to-Motorcycle TAP	CMFtap	3
Crossing	Car-to-Car	CCCscp	5
	Car-to-Motorcycle	CMCscp	5

Pedestrian & Cyclist	Scenario		Verification tests
Longitudinal	Car-to-Pedestrian	CPLA _{day}	3
		CPLA _{night}	3
	Car-to-Bicyclist	CBLA	3
Turning	Car-to-Pedestrian	CPTAfs & CPTAns	3
		CPTAfo & CPTAno	3
	Car-to-Bicyclist	CBTAfs & CBTAns	3
		CBTAfo & CBTAno	3
Crossing	Car-to-Pedestrian	CPNA _{day}	3
		CPNA _{night}	3
		CPFA _{day}	3
		CPFA _{night}	3
		CPNCO _{day}	3
		CPNCO _{night}	3
	Car-to-Bicyclist	CBNA	3
		CBFA	3
		CBNAO	3

4.2.2 Extended Range

For the Extended Range, a fixed number of 2 verification tests are randomly selected per scenario.

4.2.3 Robustness Layers

For the Robustness Layers (Decision & Control): 1 layer is randomly selected per scenario (see applicability in APPENDIX A).

For the Standard Range only, the verification tests will be performed under the presence of a randomly selected Robustness Layer where performance was predicted.

Where any verification test with the Robustness Layer applied will result in a fail, the selected robustness layer will be failed for that scenario, and the test will be repeated without the layer present. Subsequent verification tests in the Standard Range that scenario will be conducted without the layer present.

Where a specific Robustness Layer fails in two scenarios of the same collision partner (i.e., car, PTW, pedestrian, bicyclist), that layer will be failed for all scenarios of the same collision partner.

4.2.4 Additional test runs

For any verification test that does not show the predicted performance, two additional runs may be conducted (at the expense of the Vehicle Manufacturer). The two additional test runs shall pass to achieve a pass in that verification test.

4.2.5 Impact speed tolerance

As test results can be variable between labs and in-house tests and/or simulations, a 2 km/h tolerance to the impact speeds of the verification test is applied. The tolerance is applied in both directions, meaning that when a tested point scores better than predicted, but within tolerance, the predicted result is applied.

The tolerance only applies to verify whether the predicted colour of the tested verification point is correct. When, including tolerance, the colour is not in line with the prediction, the true colour of the test point will be determined by comparing the actual measured impact speed with the colour bands in section 5.2, without applying a tolerance to the impact speed.

As an example, the accepted impact speed ranges for the 60km/h CMRs test:

Colour	Impact speed range (km/h)	Accepted Range (km/h)
Green	$v_{\text{impact}} = 0$	$v_{\text{impact}} < 2$
Yellow	$0 < v_{\text{impact}} \leq 10$	$0 < v_{\text{impact}} \leq 12$
Orange	$10 < v_{\text{impact}} \leq 20$	$8 < v_{\text{impact}} \leq 22$
Brown	$20 < v_{\text{impact}} \leq 30$	$18 < v_{\text{impact}} \leq 32$
Red	$30 < v_{\text{impact}}$	

4.3 Test Conduct

4.3.1 VUT Pre-test conditioning

If requested by the Vehicle Manufacturer, an initialisation run may be included before every test run. Bring the VUT to a halt and push the brake pedal through the full extent of travel and release.

For vehicles with an automatic transmission select D. For vehicles with a manual transmission select the highest gear where the RPM will be at least 1500 at the test speed.

Perform the first test a minimum of 90s and a maximum of 10 minutes after completing the tyre conditioning (if applicable), and subsequent tests after the same time period. If the time between consecutive tests exceeds 10 minutes perform three brake stops from 72 km/h at approximately 0.3g.

Between tests, manoeuvre the VUT at a maximum speed of 50km/h and avoid riding the brake pedal and harsh acceleration, braking or turning unless strictly necessary to maintain a safe testing environment.

Control the VUT with driver inputs or using alternative control systems that can modulate the vehicle controls as necessary to perform the tests within the boundary for the AEB tests.

4.3.2 AEB tests

Accelerate the VUT and target to the respective test speeds where needed. The test shall start at T_0 and is valid when all boundary conditions are met between T_0 and T_{AEB} and/or T_{FCW} :

	VUT	GVT	EPT	EBT	EMT
Speed	+ 1.0 km/h	± 1.0 km/h	± 0.2 km/h	± 0.5 km/h	± 1.0 km/h
Lateral deviation	0 ± 0.05 m (0 ± 0.1 m for CPTA and CBTA)	0 ± 0.10 m	0 ± 0.05 m for crossing scenarios (incl. junction) 0 ± 0.15 m for longitudinal scenarios		0 ± [0.15] m
Lateral velocity			0 ± 0.15 m/s	0 ± 0.15 m/s	
Relative distance		1.0 sec [+0.1sec] time gap			1.0 sec [+0.1sec] time gap
Yaw velocity (upto T_{STEER})	0 ± 1.0 °/s				
Steering wheel velocity (upto T_{STEER})	0± 15.0 °/s				

The end of a test, where the AEB function is assessed and for CMRs FCW and CMRb FCW, is considered when one of the following occurs:

- $V_{VUT} = 0\text{km/h}$ (crossing) or $V_{VUT} = V_{\text{target}}$ (longitudinal)
- Contact between VUT and target
- The target has left the VUT path or VUT has left the target path

To avoid contact in the junction scenarios, the test laboratory may include an automated braking action by the robot in case the AEB system fails to intervene (sufficiently). This braking action is applied automatically when:

- The VUT reaches the latest position at which maximum braking applied to the vehicle will prevent the VUT entering the path of the Motorcyclist and no intervention from the AEB system is detected.
- Lateral separation between the VUT and EMT reaches $\leq 0.3\text{m}$ during / after AEB intervention.

It is at the test laboratory's discretion to select and use one of the options above to ensure a safe testing environment. If the Vehicle Manufacturer feels the avoidance action is negatively affecting the performance of their vehicle, they should consult with the test laboratory and ANCAP secretariat.

For manual or automatic accelerator control, it needs to be assured that during automatic brake the accelerator pedal does not result in an override of the system. The accelerator pedal needs to be released when the initial test speed is reduced by 5 km/h. There shall be no operation of other driving controls during the test, e.g. clutch or brake pedal.

4.3.3 FCW tests

The CCRs and CMRs FCW system tests should be performed using a braking robot reacting to the warning with a delay time of 1.2 seconds as per C.4 to account for driver reaction time.

Braking will be applied that results in a maximum brake level of $-4\text{ m/s}^2 - 0.50\text{ m/s}^2$ when applied in a non-threat situation. The particular brake profile to be applied (pedal application rate applied in 200ms (max. 400mm/s) and pedal force) shall be specified by the manufacturer. When the brake profile provided by the manufacturer results in a higher brake level than allowed, the iteration steps as described in Euro NCAP Technical Bulletin CA 102 will be applied to scale the brake level to $-4\text{ m/s}^2 - 0.50\text{ m/s}^2$.

If no brake profile is provided, apply default brake profile as described in Euro NCAP Technical Bulletin CA 102.

Where the FCW function is assessed, the end of a test is considered when one of the following occurs:

- $V_{VUT} = V_{\text{target}}$ (longitudinal)
- T_{FCW}
- $TTC \leq 1.5\text{s}$, after which an evasive action can be started

It is at the labs discretion to select and use one of the options above to ensure a safe testing environment.

5 ASSESSMENT

Each scenario in this assessment consists of a matrix combining vehicle longitudinal speeds, and ranges of impact locations or target longitudinal speeds. Each combination in a matrix is referred to as grid cell. The grid cells forming a matrix are grouped into 2 groups: 1) Standard Range and 2) Extended Range.

In addition, a number of points are awarded on each scenario for system Robustness, with Robustness Layers assessed against grid cells of the Standard Range where there is performance, as described in 5.2.1.

5.1 General requirements

To be eligible for scoring points in this assessment, the following conditions shall be met:

- AEB and/or FCW system shall be default ON at the start of every journey and deactivation of the system should not be possible with a momentary single push on a button.
- AEB and/or FCW system shall have a loud and clear audible component of the FCW system (if applicable).
- For AEB Pedestrian, the system shall operate (i.e. warn or brake) from speeds of 10 km/h in the CPNA-75 scenario in both day and night. In addition, the system shall be able to detect pedestrians walking as slow as 3 km/h and reduce speed in the CPNA-75 scenario at 20 km/h, also for both day and night.
- For the AEB CCRs scenario, full avoidance shall be achieved for test speeds up to and including 20 km/h for all impact locations within the Standard Range, which is verified by one randomly selected test point.

5.2 Criteria

The following criteria and associated KPIs is used across scenarios to evaluate the performance of the AEB and/or FCW system:

Criteria	KPI	Scenarios	
		Car & PTW	Pedestrian & Cyclist
Mitigation OR avoidance	V_{rel_impact}	CCRs, CCRm, CCRb CMRs, CMRb	CPLA, CBLA(<50 km/h) CPNA, CPFA, CPNAO CBNA, CBFA, CBNAO
Mitigation	$V_{reduction}$	CCFhos, CCFhol	-
Avoidance	V_{impact}	CCFtap, CMFtap CCCscp, CMCscp	CPTA, CBTA
Warning	FCW TTC	-	CPLA, CBLA (≥50 km/h),

Where V_{rel_impact} or $V_{reduction}$ is used, a criteria based on a stepped sliding scale using colour bands is applied:

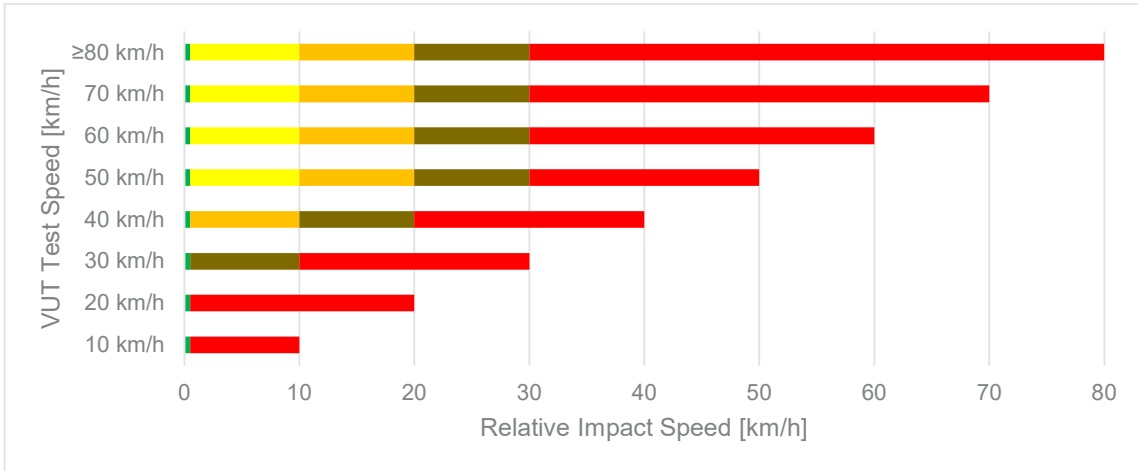

Figure 5-1 Relative Impact Speed colour band criteria (applicable to Car & PTW Rear, and Pedestrian & Cyclist Longitudinal / Crossing)



Figure 5-2 Speed Reduction colour band criteria (applicable to Car & PTW Front)

Where V_{impact} or FCW TTC is used, the following criteria applies:

Colour band	KPI	
	V_{impact} [km/h]	FCW TTC [s]
Green	0	≥ 1.7
Red	> 0	< 1.7

5.2.1 Robustness Layers

The Robustness Layers are clustered in two categories: Decision & Control and Perception.

5.2.1.1 Decision & Control

Robustness layers (Decision & Control)		Description	Verification Test	Performance prediction source
Type	Layer			
VUT	Driver input pre-crash	Normal driving without steering robot and/or speed control function	Yes	OEM information on system overriding conditions
Target	Speed	Small variance in the nominal target speed	Yes	Virtual Testing or Self-claimed
	Acceleration	Small variance in the nominal target acceleration	Yes	
	Initial position offset	Small variance in the nominal target initial position	Yes	
	Trajectory/ Heading	Small variance in the nominal target heading	Yes	

5.2.1.2 Perception

Robustness layers (Perception)		Description	Verification Test	Performance prediction source
Type	Layer			
Target	Type	Different collision partner type (e.g., Car: Vehicle Cat.: N1, N2, N3 PTW: Vehicle Cat.: L1, Bicyclist: Powered Standing Scooter)	No	Field Data**
	Appearance	Same collision partner type but with different appearance (e.g., colour, accessories, shape)	No	
Environment	Adverse weather conditions	Functionality available under the presence of Rain, Fog, Dirt/ice/moisture	No	
	Illumination (Night time)	Performance in darkness (1 lux) for all daytime scenarios	No*	
	Illumination - Glare	Functionality available under the presence of glare caused by Low sun (all scenarios)	No	
		Performance under the presence of glare caused by headlights of a stationary vehicle on adjacent lane (all standard nighttime scenarios)	No*	
Infrastructure / clutter	Performance in environments cluttered with objects such as urban furniture or secondary road users (without fully obscuring the main target)	No*		

Robustness layers (Perception)		Description	Verification Test	Performance prediction source
Type	Layer			
	Obscuration / Obstruction	Variance in the layout of nominal obstructions	No*	

* Verification test may be conducted under request of ANCAP Secretariat.

** As outlined in 4.1.3

5.2.1.3 Verification Tests Conditions

For the Robustness Layers where verification tests shall or may be done, the following conditions apply:

VUT Robustness layers		Verification condition*	Assessment Criteria
Layer	Scenarios		
Driver input pre-crash	Longitudinal	<ul style="list-style-type: none"> T_{Diver_steer} @ 4.0s TTC T_{Driver_throttle} @ 8.0s TTC Resulting Impact location must be within the range where the OEM predicted performance 	Same or better than Standard Range**
	Crossing, C2P, C2B	<ul style="list-style-type: none"> T_{Diver_steer} @ 4.0s TTC T_{Driver_throttle} @ [4.0]s TTC Resulting Impact location must be within the range where the OEM predicted performance 	
	Crossing C2C, C2M	<ul style="list-style-type: none"> T_{Diver_steer} @ 4.0s TTC T_{Driver_throttle} @ [4.0]s TTC Impact location tolerance (against nominal) ±20% 	
	Turning	<ul style="list-style-type: none"> VUT Lateral deviation 0 ± 0.4 m (manual turn) Impact location tolerance (against nominal) ±20% 	

**Against the closest grid cell

Target Robustness layers		Verification condition*	Assessment Criteria
Layer	Scenarios		
Speed	CCFhos/hol	±5 km/h	≠red
	CCFtap, CMFtap CCCscp, CMCscp		Same or better than Standard Range
	CPTA	+3 km/h	

Target Robustness layers		Verification condition*	Assessment Criteria
Layer	Scenarios		
	CBTA	+5 km/h	
	CPNA, CPFA, CPNCO	+3 km/h	≠red
		-2 km/h	Same or better than Standard Range
	CBNA, CBFA, CBNAO	+5 km/h	≠red
		-3 km/h	Same or better than Standard Range
	Acceleration	CCRb, CMRb	+2 m/s ²
-2 m/s ²			≠red
Initial position offset	CPNA, CPFA, CBNA, CBFA, CPNCO, CBNAO	-25% m of distance to impact point	≠red
	CPTA		Same or better than Standard Range
	CCFtap, CMFtap, CBTA	±0.5m Path offset	
	CCRb, CMRb	±0.5s Time headway	≠red
Trajectory/ Heading	CCRs, CMRs CPNA, CPFA, CBNA, CBFA, CPNCO, CBNAO	±20° (rotation around the impact point)	Same or better than Standard Range

5.2.1.4

Environment robustness layers		Verification condition*	Assessment Criteria
Layer	Scenarios		
Illumination (Night time)	ALL except Standard nighttime scenarios	Performance in darkness (1 lux) for all daytime scenarios	≠red
Illumination – Glare	ALL Standard nighttime scenarios	Headlight of stationary vehicle on adjacent lane	≠red
Infrastructure / clutter	CCRs	Vehicle aside of main target	Same or better than Standard Range

Environment robustness layers		Verification condition*	Assessment Criteria
Layer	Scenarios		
	CMRs	Vehicle aside of main target OR GVT in front of main target	
	CCRm, CCRb, CMRb	Vehicle aside of main target (moving)	
	CCRb	GVT in front of main target (moving)	
	Turning (C2P, C2B)	Typical crossing scenery e.g., traffic sign, refuge, trash bin	
	CCCscp, CMCscp	Typical crossing scenery e.g., traffic sign, stationary pedestrians on sidewalk, stationary (secondary) GVT on crossing road	
	CPNA, CPFA	Randomly selected case from Euro NCAP Technical Bulletin CA 002	
	CBNA, CBFA	Randomly selected case from Euro NCAP Technical Bulletin CA 002 <i>(To be further populated with Bicyclist cases over the course of 2025)</i>	≠red
Obscuration / Obstruction	CPNCO	Randomly selected CPNCO case from Euro NCAP Technical Bulletin CA 002	≠red
	CBNAO	Randomly selected CBNCO case from Euro NCAP Technical Bulletin CA 002 <i>(To be further populated with Bicyclist cases over the course of 2025)</i>	≠red

* Versus the condition used in the Standard Range (excluding red cells)

5.3 Scoring

5.3.1 Standard Ranges

For score calculation in the Standard Range of each scenario, first each grid cell is given a sub-score according to the Vehicle Manufacturer colour prediction:

Predicted Colour	Standard Range Sub-score per grid cell
Green	1.00
Yellow	0.75
Orange	0.50
Brown	0.25
Red	0.00

Secondly, the resulting score is calculated by normalizing all the Standard Range sub-scores to the total score of the Standard Range in that scenario(rounded to hundredth):

$$\text{Score Standard Range} = \frac{\sum \text{Subscores in Standard Range}}{\text{Total Standard Range Score}}$$

5.3.2 Extended Ranges

For score calculation in the Extended Range of each scenario, first each grid cell is given a sub-score according to the Vehicle Manufacturer prediction:

Predicted Colour	Extended Range Sub-score per grid cell
Green	1.00
Yellow	
Orange	
Brown	
Red	0.00

Secondly, the resulting score is calculated by normalizing all the Extended Range sub-scores to the total score of the Extended Range in that scenario(rounded to hundredth):

$$\text{Score Extended Range} = \frac{\sum \text{Subscores in Extended Range}}{\text{Total Extended Range Score}}$$

The final score for each Extended Range in a given scenario is calculated as follows:

Extended Range Scoring	
% of total score	Final score
$50 \leq \text{Score Extended Range} < 75$	50%
$75 \leq \text{Score Extended Range} < 100$	75%
Score Extended Range = 100	100%

5.3.2.1 AES

For the impact locations in the Extended Range, the Vehicle Manufacturer may implement an AES function that provides full avoidance by in-lane steering. The Vehicle Manufacturer shall elaborate to ANCAP the AES function strategy and will provide a specific test method to verify performance, which shall be carried out by the test laboratory.

5.3.2.2 ESS

For the following situations, the Vehicle Manufacturer may implement an ESS function that is effective at supporting the driver in fully avoiding a collision by a steering manoeuvre:

Steering manoeuvre	Direction	Scenario	VUT speed	Impact location
In-lane	Farside and/or Nearside	CCRs	≥60 km/h	-25%, 125%
		CMRs		10%, 90%
		CPLA, CBLA	≥50 km/h	10%, 75%
Partial lane change*	Farside	CCRs	≥60 km/h	0%, 25%, 50%
		CMRs		50%, 25%
		CPLA, CBLA	≥50 km/h	25%, 50%

* Only when ESS is able to evaluate free space in neighbour lane. If neighbour lane is obstructed or occupied with oncoming/overtaking traffic, the performance criteria should be based on nominal conditions (i.e., FCW to be issued ≥1.7s TTC for CPLA & CBLA / speed reduction by FCW/AEB for CCRs/CMRs).

The Vehicle Manufacturer shall elaborate to ANCAP the ESS function strategy and will provide a specific test method to verify performance, which shall be carried out by the test laboratory.

5.3.3 Robustness Layers

To be eligible for scoring points in Robustness Layers in a specific scenario, there shall be ≥50% of the total available score in the Standard Range of that scenario.

The score for each Robustness Layer in each scenario where the manufacturer predicted performance according to 5.2.1 is calculated as follows:

$$\text{Score Robustness Layer} = \frac{\text{Number of applicable Robustness Layers}}{\text{Total Robustness Score}}$$

An overview of the applicable Robustness Layers in each scenario can be found in APPENDIX A.

5.3.4 Verification tests

The outcome of the verification tests will dictate the final score of a given scenario, and will depend on how the predicted performance is reported by the Vehicle Manufacturer, as illustrated in the table below:

# of tests→ Passed* tests↓	Score % from verification tests outcome							
	Standard Range						Extended Range	
	Virtual Testing Predictions			Self-claim Predictions			Virtual Testing Predictions	Self Claim Predictions
	5	4	3	5	4	3	2	2
5	100%	-	-	100%	-	-	-	-
4	80%	100%	-	80%	100%	-	-	-
3	60%	75%	100%	0%	75%	100%	-	-
2	40%	50%	67%	0%	0%	67%	100%	100%
1	20%	25%	33%	0%	0%	0%	50%	0%
0	0%	0%	0%	0%	0%	0%	0%	0%

* Passed = in line or beyond the predicted performance

If a verification tests applied in a scenario where performance was predicted by Virtual Testing does not meet the acceptance criteria set forth in the VTA protocol, all scenarios in that cluster will be treated as Self claim for scoring.

5.4 Links to Driver State

The Vehicle Manufacturer may implement a sensitivity change strategy for FCW and/or AEB according to the state of the driver detected by the DSM as described in the ANCAP Driver Engagement protocol, provided that following conditions are met:

- The DSM shall offer minimum performance across different driver states:
 - o Transient states: >50% of total score in Forward Support Sensitivity intervention
 - o Non-transient states: Drowsiness and Sleep
- The sensitivity change shall be set back to the nominal setting < 1 second after the DSM system is in degraded mode, non-functional or turned off.

The criteria for sensitivity change is based on the speed reduction that either FCW and/or AEB shall offer as a minimum across different scenarios when linked to the driver state, as summarized in the table below:

FCW/AEB Sensitivity Change			
Impact location ranges	Standard Range adjacent to Extended Range	Extended Range	Extended Range
AEB/FCW	FCW and/or AEB	FCW and/or AEB	AEB
Frontal Collision Scenarios	CCRs, CMRs	CCRs, CMRs	CPNA, CPFA, CBNA, CBFA
	CCRm	CCRm	CPTA, CBTA
	CCRb, CMRb	CCRb, CMRb	CCCscp, CMCscp
		CPLA, CBLA	CCFhos, CCFhol
Acceptance criteria*	≤ 1 colour down	≠red OR suppression	

* Assessed under Attentive and/or unimpaired driver state

The vehicle manufacturer may request, for the scenarios in the table above, that the verification test is performed with a test driver that is classified as distracted.

In addition, ANCAP may verify that the acceptance criteria is met as described in the table above, under the attentive driver condition.

For FCW tests, the brake robot actuation will be delayed 1.2 seconds by default from the start of the acoustic warning, accounting for the reaction time of a driver assumed to be distracted and/or impaired. However, the Vehicle Manufacturer may implement alternative driver models in the FCW strategy based on the true state of the driver detected by DSM, and/or alternative/supplementary FCW strategies which are effective at reducing driver reaction times:

- Distracted/impaired driver: 1.2 seconds
- Attentive driver : -[0.5] seconds
- Alternative/supplementary FCW e.g., seatbelt jerk: -[0.25] seconds

In addition, driver models based on steering may be used to avoid a crash against a road user travelling in the same direction at a high offset e.g., ESS function for CPLA, CBLA and CCR/CMR, provided the driver is classified as distracted or impaired.

The Vehicle Manufacturer shall document in detail to ANCAP the FCW and/or AEB strategy when linked to the state of the driver as detected by the DSM, including specific test provisions to verify performance under the distracted/impaired setting.

APPENDIX A APPLICABILITY OF ROBUSTNESS LAYERS

A.1 Car-to-Car Scenarios

Type	Robustness Layer	Assessment	CCRs	CCRm	CCRB	CCFhos	CCFhol	CCFtap	CCCscp
VUT	Driver input pre-crash	Verification Test	YES	YES	YES	n/a	n/a	YES	YES
Target	Speed	Verification Test	n/a	n/a	n/a	YES	YES	YES	YES
	Acceleration	Verification Test	n/a	n/a	YES	n/a	n/a	n/a	n/a
	Initial position offset	Verification Test	n/a	n/a	YES	n/a	n/a	YES	n/a
	Trajectory/ Heading	Verification Test	YES	n/a	n/a	n/a	n/a	n/a	n/a
	Type	Field Data	YES	YES	YES	YES	YES	YES	YES
	Appearance	Field Data	YES	YES	YES	YES	YES	YES	YES
Environment	AWC	Field Data	YES	YES	YES	YES	YES	YES	YES
	Illumination (Night)	Field Data*	YES	YES	YES	YES	YES	YES	YES
	Illumination (Glare)	Field Data	YES	YES	YES	YES	YES	YES	YES
	Infrastructure / Clutter	Field Data*	YES	YES	YES	n/a	n/a	n/a	YES
	Obscuration / Obstruction	Field Data*	n/a	n/a	n/a	n/a	n/a	n/a	n/a

* NOT to be selected as part of the *Verification tests process*. This layer may only be conducted under request of ANCAP Secretariat.

A.2 Car-to-PTW Scenarios

Type	Robustness Layer	Assessment	CMRs	CMRb	CMFtap	CMCscp
VUT	Driver input pre-crash	Verification Test	YES	YES	YES	YES
Target	Speed	Verification Test	n/a	n/a	YES	YES
	Acceleration	Verification Test	n/a	YES	n/a	n/a
	Initial position offset	Verification Test	n/a	YES	YES	n/a
	Trajectory/ Heading	Verification Test	YES	n/a	n/a	n/a
	Type	Field Data	YES	YES	YES	YES
	Appearance	Field Data	YES	YES	YES	YES
Environment	AWC	Field Data	YES	YES	YES	YES
	Illumination (Night)	Field Data*	YES	YES	YES	YES
	Illumination (Glare)	Field Data	YES	YES	YES	YES
	Infrastructure / Clutter	Field Data*	YES	YES	n/a	YES
	Obscuration / Obstruction	Field Data*	n/a	n/a	n/a	n/a

* NOT to be selected as part of the *Verification tests process*. This layer may only be conducted under request of ANCAP Secretariat.

A.3 Car-to-Pedestrian Scenarios

Type	Robustness Layer	Assessment	CPLA	CPTA	CPNA	CPFA	CPNCO
VUT	Driver input pre-crash	Verification Test	YES	YES	YES	YES	YES
Target	Speed	Verification Test	n/a	YES	YES	YES	YES
	Acceleration	Verification Test	n/a	n/a	n/a	n/a	n/a
	Initial position offset	Verification Test	n/a	YES	YES	YES	YES
	Trajectory/ Heading	Verification Test	n/a	n/a	YES	YES	YES
	Type	Field Data	YES	YES	YES	YES	YES
	Appearance	Field Data	YES	YES	YES	YES	YES
Environment	AWC	Field Data	YES	YES	YES	YES	YES
	Illumination (Night)	Field Data*	n/a	YES	n/a	n/a	n/a
	Illumination (Glare)	Field Data*	YES	n/a	YES	YES	YES
	Infrastructure / Clutter	Field Data*	YES	YES	YES	YES	YES
	Obscuration / Obstruction	Field Data*	n/a	n/a	n/a	n/a	YES

* NOT to be selected as part of the *Verification tests process*. This layer may only be conducted under request of ANCAP Secretariat.

A.4 Car-to-Bicyclist Scenarios

Type	Robustness Layer	Assessment	CBLA	CBTA	CBNA	CBFA	CBNAO
VUT	Driver input pre-crash	Verification Test	YES	YES	YES	YES	YES
Target	Speed	Verification Test	n/a	YES	YES	YES	YES
	Acceleration	Verification Test	n/a	n/a	n/a	n/a	n/a
	Initial position offset	Verification Test	n/a	YES	YES	YES	YES
	Trajectory/ Heading	Verification Test	n/a	n/a	YES	YES	YES
	Type	Field Data	YES	YES	YES	YES	YES
	Appearance	Field Data	YES	YES	YES	YES	YES
Environment	AWC	Field Data	YES	YES	YES	YES	YES
	Illumination (Night)	Field Data*	YES	YES	YES	YES	YES
	Illumination (Glare)	Field Data	YES	YES	YES	YES	YES
	Infrastructure / Clutter	Field Data*	YES	YES	YES	YES	YES
	Obscuration / Obstruction	Field Data*	n/a	n/a	n/a	n/a	YES

* NOT to be selected as part of the *Verification tests process*. This layer may only be conducted under request of ANCAP Secretariat.

APPENDIX B OBSTRUCTION DIMENSIONS

B.1 Smaller obstruction vehicle

The smaller obstruction vehicle should be of the category Small Family Car and is positioned closest to the pedestrian path. The smaller obstruction vehicle should be within the following geometrical dimensions and needs to be in a dark colour.

	Vehicle length	Vehicle width (without mirrors)	Vehicle height	Bonnet length (till A pillar)	BLE height
Minimum	4100 mm	1700 mm	1300 mm	1100 mm	650 mm
Maximum	4400 mm	1900 mm	1500 mm	1500 mm	800 mm

B.2 Larger obstruction vehicle

The larger obstruction vehicle should be of the category Small SUV and is positioned behind the smaller obstruction vehicle. The larger obstruction vehicle should be within the following geometrical dimensions and needs to be in a dark colour.

	Vehicle length	Vehicle width (without mirrors)	Vehicle height
Minimum	4300 mm	1750 mm	1500 mm
Maximum	4700 mm	1900 mm	1800 mm