

# Operator Manual

Cummins **Onan**

Performance you rely on.™



## RV Generator Set

HGJAA (Spec J)

HGJAB (Spec J)



# Table of Contents

---

1. SAFETY PRECAUTIONS .....	1
1.1 General Precautions .....	1
1.2 Generator Voltage is Deadly.....	1
1.3 Engine Exhaust is Deadly.....	2
1.4 Fuel is Flammable and Explosive.....	2
1.5 Battery Gas is Explosive.....	2
1.6 Moving Parts Can Cause Severe Personal Injury or Death .....	2
2. INTRODUCTION.....	5
2.1 About This Manual.....	5
2.2 Nameplate.....	5
2.3 Typical Genset.....	6
2.4 Fuel Recommendations .....	7
2.4.1 Gasoline Models .....	8
2.4.2 LPG Models .....	8
2.5 Engine Oil Recommendations .....	8
2.6 Starting Batteries .....	9
2.7 Genset Control Panel.....	9
2.8 Remote Control Panel.....	9
3. OPERATION .....	11
3.1 Conducting Pre-Start Checks .....	11
3.2 Priming Gasoline Fuel Systems.....	11
3.3 Starting the Genset.....	12
3.4 Stopping the Genset.....	12
3.5 Restarting the Genset.....	12
3.6 Engine Run Only Operation.....	12
3.7 Loading the Genset.....	13
3.8 Resetting Circuit Breakers .....	14
3.9 Connecting Utility Power.....	14
3.10 Operating in Cold Weather .....	15
3.11 Operating in Hot Weather .....	15
3.12 Operating at High Altitude.....	15
3.13 Operating in Dusty Environments .....	16
3.14 Breaking in a New Engine .....	16
3.15 Exercising the Genset.....	17
3.16 Storing the Genset.....	17
3.16.1 Storing Genset.....	17
3.16.2 Returning Genset to Service.....	17
4. PERIODIC MAINTENANCE.....	19
4.1 Conducting General inspections.....	19
4.1.1 Oil Level .....	19

---

4.1.2 Exhaust System .....	20
4.1.3 Fuel System .....	20
4.1.4 Battery Connections.....	20
4.1.5 Mechanical .....	21
4.2 Checking Engine Oil Level.....	21
4.3 Changing Engine Oil and Oil Filter .....	22
4.4 Maintaining Battery and Battery Connections.....	23
4.5 Replacing the Air Filter Element .....	23
4.6 Replacing Spark Plugs.....	24
4.7 Cleaning the Spark Arrestor .....	25
5. TROUBLESHOOTING .....	27
5.1 Fault Codes.....	27
6. SPECIFICATIONS .....	33
7. INFORMATION FOR CALIFORNIA GENSET USERS.....	37
8. HOW TO OBTAIN SERVICE .....	39
9. MAINTENANCE RECORD.....	41



# 1 Safety Precautions

---

Thoroughly read the OPERATOR'S MANUAL before operating the genset. Safe operation and top performance can only be obtained when equipment is properly operated and maintained.

The following symbols in this manual alert you to potential hazards to the operator, service person and equipment.



**DANGER:** alerts you to an immediate hazard that will result in severe personal injury or death.



**WARNING:** alerts you to a hazard or unsafe practice that can result in severe personal injury or death.



**CAUTION:** alerts you to a hazard or unsafe practice that can result in personal injury or equipment damage.

Electricity, fuel, exhaust, moving parts and batteries present hazards which can result in severe personal injury or death.

## 1.1 General Precautions

- Keep ABC fire extinguishers handy.
- Keep children away from the genset.
- Make sure all fasteners are secure and torqued properly.
- Keep the genset and its compartment clean. Excess oil and oily rags can catch fire. Do not store gear in the compartment it can restrict cooling air.
- Before working on the genset, disconnect the negative (-) battery cable at the battery to prevent accidental starting.
- Use caution when making adjustments while the genset is running—hot, moving or electrically live parts can cause severe personal injury or death.
- Used engine oil has been identified by some state and federal agencies as causing cancer or reproductive toxicity. Do not ingest, inhale, or contact used oil or its vapors.
- Benzene and lead in some gasolines have been identified by some state and federal agencies as causing cancer or reproductive toxicity. Do not to ingest, inhale or contact gasoline or its vapors.
- Do not work on the genset when mentally or physically fatigued or after consuming alcohol or drugs.
- Carefully follow all applicable local, state and federal codes.

## 1.2 Generator Voltage is Deadly

- Disable the automatic genset starting feature(AGS) of an inverter-charger or other automatic starting device before servicing the genset to avoid electric shock from an unexpected start.

- Generator output connections must be made by a qualified electrician in accordance with applicable codes.
- The genset must not be connected to the public utility or any other source of electrical power. Connection could lead to electrocution of utility personnel and damage to equipment. An approved switching device must be used to prevent interconnections.
- Use caution when working on live electrical equipment. Remove jewelry, make sure clothing and shoes are dry and stand on a dry wooden platform.

### **1.3 Engine Exhaust is Deadly**

- Learn the symptoms of carbon monoxide poisoning in this manual and never occupy the vehicle while the genset is running unless the vehicle is equipped with a working carbon monoxide detector.
- The exhaust system must be installed in accordance with the genset Installation Manual. Engine cooling air must not be used for heating the working or living space or compartment.
- Inspect for exhaust leaks at every startup and after every eight hours of running.
- Disable the automatic genset starting feature of an inverter-charger or other automatic starting device before storing the vehicle or parking it in a garage or other confined space.
- Make sure there is ample fresh air when operating the genset in a confined area.

### **1.4 Fuel is Flammable and Explosive**

- Do not smoke or turn electrical switches ON or OFF where fuel fumes are present or in areas sharing ventilation with fuel tanks or equipment. Keep flame, sparks, pilot lights, arc-producing equipment and all other sources of ignition well away.
- Fuel lines must be secured, free of leaks and separated or shielded from electrical wiring.
- Leaks can lead to explosive accumulations of gas. LPG sinks when released and can accumulate inside housings and basements and other below-grade spaces. Prevent leaks and the accumulation of gas.

### **1.5 Battery Gas is Explosive**

- Wear safety glasses and do not smoke while servicing batteries.
- When disconnecting or reconnecting battery cables, always disconnect the negative (-) battery cable first and reconnect it last to reduce arcing.

### **1.6 Moving Parts Can Cause Severe Personal Injury or Death**

- Disable the automatic genset starting feature(AGS) of an inverter-charger or other automatic starting device before servicing the genset to avoid unexpected starting.
- Do not wear loose clothing or jewelry near moving parts such as PTO shafts, fans, belts and pulleys.

- Keep hands away from moving parts.
- Keep guards in place over fans, belts, pulleys, etc.

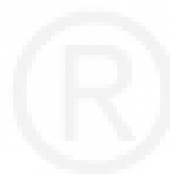

This page is intentionally blank.



# 2 Introduction

---

## 2.1 About This Manual

This manual covers the operation and maintenance of the HGJAA and HGJAB Series of generator sets (gensets). Each operator should study this manual carefully and observe all of its instructions and safety precautions. Keep this manual and the Installation Manual with the other vehicle manuals.

*Operation, Periodic Maintenance and Troubleshooting* provide the instructions necessary for operating the genset and maintaining it at top performance. The owner is responsible for performing maintenance in accordance with the PERIODIC MAINTENANCE SCHEDULE (See Periodic Maintenance Section). This manual also includes genset specifications, information on how to obtain service, and information for California users.



**WARNING:** *This genset is not a life support system. It can stop without warning. Children, persons with physical or mental limitations, and pets could suffer personal injury or death. A personal attendant, redundant power or an alarm system must be used if genset operation is critical.*

## 2.2 Nameplate

**Model and Serial Numbers:** Have the model and serial numbers handy (gray boxes, [Figure 1](#)) when contacting an Onan dealer for parts, service or product information. Each character is significant. (The last character of the model number is the specification letter, which is important for obtaining the right parts.) Record these numbers in the boxes in [Figure 1](#) so that they are handy when you need them.

Genuine Onan replacement parts are recommended for best performance and safety.

**Federal Emissions Compliance Period:** The Federal Emissions Compliance Period referred to on the nameplate indicates the number of operating hours for which the engine has been shown to meet Federal emissions requirements. Category C = 250 hrs, B = 500 hrs, A = 1000 hrs.

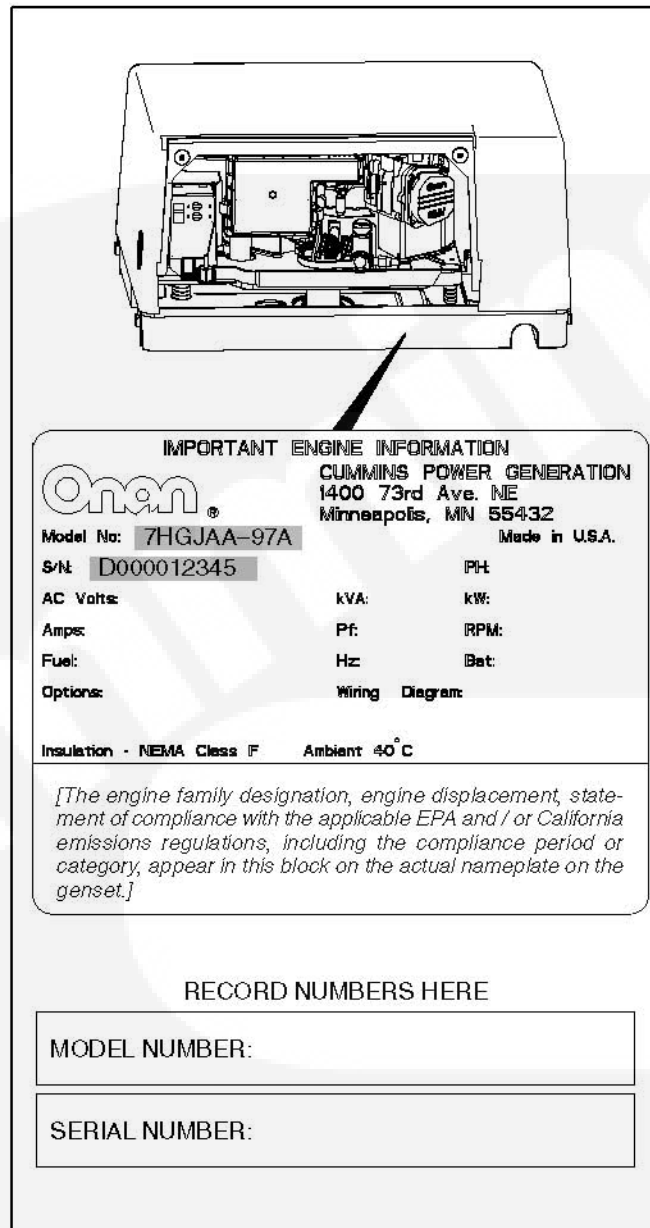

**FIGURE 1. TYPICAL NAMEPLATE**

## 2.3 Typical Genset

[Figure 2](#) illustrates a typical self-enclosed genset with the maintenance access cover removed.

**Removing the access cover:** Pull the top of the cover outward and lift it away.

**Securing the access cover:** Catch the bottom lip of the cover on the top edge of the base tray and firmly push it into place.

If the cover pins and rubber grommets do not line up, check that the edging on the top edge of the base tray lies flat and is pushed down all the way.

If the cover feels loose, one of the rubber grommets probably pushed through. If so, remove the cover, insert the grommet back into its hole and try again.



**CAUTION:** Operating the genset with the access cover off can lead to overheating of components. Always secure the cover after starting the genset.

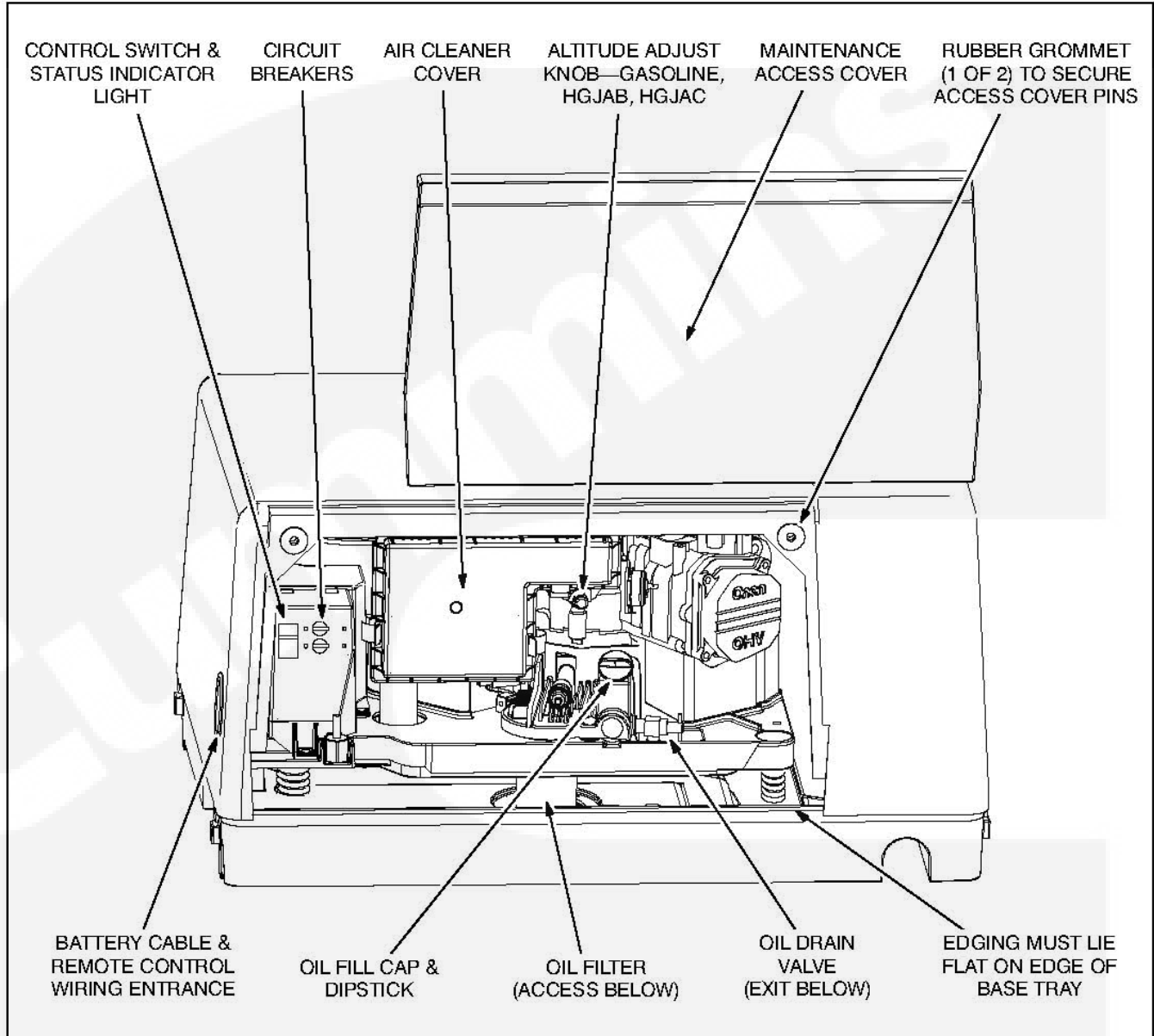

FIGURE 2. TYPICAL SELF-ENCLOSED GENSET

## 2.4 Fuel Recommendations



**WARNING:** Gasoline and LPG are highly flammable and explosive and can cause severe personal injury or death. Do not smoke or turn electrical switches ON or OFF where fuel fumes, tanks or equipment are present or in areas sharing ventilation. Keep flames, sparks, pilot lights, arc-producing equipment and switches and all other sources of ignition well away. Keep a type ABC fire extinguisher in the vehicle.

## 2.4.1 Gasoline Models

Use clean, fresh unleaded gasoline having a minimum octane rating (Anti-Knock Index) of 87.

- Ethanol Blend - Not more than 10% ethanol.
- Methanol Blend - Not more than 5% methanol and the fuel must also contain solvents and corrosion inhibitors.



**CAUTION:** *Do not use gasoline or gasoline additives containing methanol because methanol can be corrosive to fuel system components.*

*Avoid using leaded gasoline because of the extra engine maintenance that will be required.*

## 2.4.2 LPG Models

Use clean, fresh HD-5 grade liquified petroleum gas (LPG) or equivalent product consisting of at least 90 percent propane. Commercial liquified petroleum gas fuels may contain more than 2.5 percent butane which can result in poor fuel vaporization and poor engine starting in low ambient temperatures (below 32° F (0° C)).

Satisfactory performance on low-pressure LPG models requires that the LPG vapor be supplied at a pressure within the range indicated in *Specifications*.



**WARNING:** *High LPG supply pressure can cause gas leaks which can lead to fire and severe personal injury or death. LPG supply pressure must be adjusted to Specifications by trained and experienced personnel.*

## 2.5 Engine Oil Recommendations

Use API (American Petroleum Institute) performance Class **SJ**, **SH** or **SG** engine oil, which may be in combination with performance Class CH-4, CG-4 or CF-4 (for example: SJ/CH-4). Also look for the SAE (Society of Automotive Engineers) viscosity grade. Referring to [Table 1](#), choose the viscosity grade appropriate for the ambient temperatures expected until the next scheduled oil change.

Single-grade SAE 30 oil is preferable when temperatures are consistently above freezing. Multigrade oils are better when wide temperature variations are expected.

**TABLE 1. OIL VISCOSITY VS. TEMPERATURE**

EXPECTED AMBIENT TEMPERATURES	SAE VISCOSITY GRADE
32° F (0° C) and higher	30
10° F to 100° F (-12° C to 38° C)	15W-40 (OnaMax™)
0° F to 80° F (-18° C to 27° C)	10W-30 10W-40
-20° F to 50° F (-28° C to 10° C)	5W-30

OnaMax is a trademark of Onan Corporation.

## 2.6 Starting Batteries

The genset has a 12 volt, direct current (DC) engine cranking and control system. See *Specifications* regarding minimum battery ratings for reliable genset cranking, especially in cold weather. Also see Periodic Maintenance Schedule and the battery manufacturer's instructions regarding battery maintenance. Reliable genset starting and starter service life depend upon adequate battery system capacity and proper maintenance.

## 2.7 Genset Control Panel

The genset control panel ( [Figure 3](#) ) is located behind the maintenance access cover ( [Figure 4](#) ) and has the following features:

**Control Switch** - This switch is used to prime the fuel system, start and stop the genset and display the fault code. Hold the switch in its **START** position to crank and start the genset. Press the switch to its **STOP** position to stop the genset. Hold the switch in its **STOP/PRIME** position (starts in 2 seconds) to prime the fuel system (gasoline models only). See [Chapter 5 on page 27](#) about displaying fault codes.

**Status Indicator Light** - This light is an LED (light emitting diode) in the control switch which blinks rapidly during cranking and comes on solid when the starter disconnects, indicating that the genset is running. If the genset shuts down abnormally, the light will blink a code to indicate the cause of the shutdown. See [Chapter 5 on page 27](#).

**Line Circuit Breaker** -The line circuit breaker protects the AC power leads connected to the genset from overloads and equipment short circuits.

## 2.8 Remote Control Panel

The vehicle probably has a control panel inside the vehicle for remote control of the genset. Onan offers three remote control kits as follows:

- Remote switch with status indicator light only ( [Figure 4](#) ).
- Remote switch with status indicator light and hour meter ( [Figure 5](#) ).
- Remote switch with status indicator light and DC voltmeter ( [Figure 6](#) ).

The hour meter (time totalizing meter) records genset operating time in hours. It cannot be reset. See the [Chapter 4 on page 19](#) Schedule.

The DC voltmeter indicates whether voltage across the 12 VDC control system and battery is normal. If the indicator consistently stays above or below the normal zone, see [Section 4.4 on page 23](#).

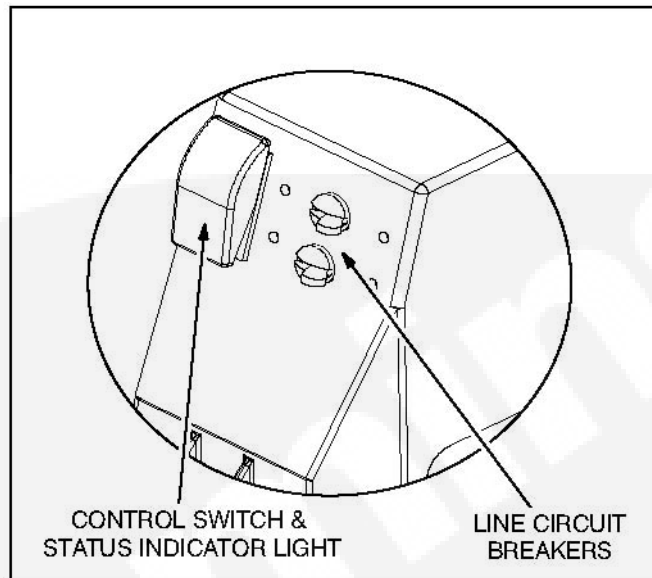

**FIGURE 3. GENSET CONTROL PANEL**

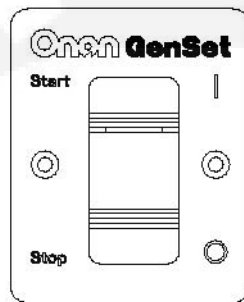

**FIGURE 4. REMOTE SWITCH**

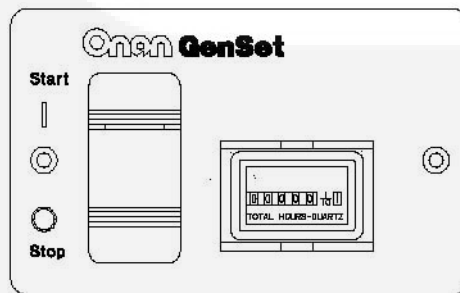

**FIGURE 5. REMOTE SWITCH / HOUR METER**

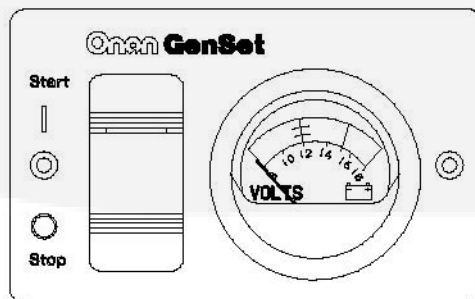

**FIGURE 6. REMOTE SWITCH / DC VOLTMETER**

# 3 Operation

---



## **WARNING: EXHAUST GAS IS DEADLY!**

*Exhaust gases contain carbon monoxide, an odorless, colorless gas. Carbon monoxide is poisonous and can cause unconsciousness and death. Symptoms of carbon monoxide poisoning include:*

- *Dizziness*
- *Muscular Twitching*
- *Weakness and Sleepiness*
- *Throbbing in Temples*
- *Headache*
- *Inability to Think Clearly*
- *Nausea*
- *Vomiting*

*IF YOU OR ANYONE ELSE EXPERIENCES ANY OF THESE SYMPTOMS, GET OUT INTO THE FRESH AIR IMMEDIATELY. If symptoms persist, seek medical attention. Shut down the genset and do not operate it until it has been inspected and repaired.*

*Never occupy the vehicle with the genset running unless the vehicle is equipped with a working carbon monoxide detector. Primary protection against inhaling carbon monoxide, however, is proper installation of the exhaust system, daily (every eight hour) inspection for visible and audible exhaust system leaks.*

## 3.1 Conducting Pre-Start Checks

Before the first start of the day and after every eight hours of operation, inspect the genset as instructed under [Section 4.1 on page 19](#). Keep a log of maintenance and the hours run and perform any maintenance that may be due. See [Section 4.1 on page 19](#) if the vehicle has been in storage.

Before each start:

1. Make sure all vehicle CO detectors are working.
2. Check for signs of fuel and exhaust leaks and for damage to the exhaust system.
3. Turn off the air conditioner and other large appliances.

## 3.2 Priming Gasoline Fuel Systems

If a gasoline genset ran out of fuel prime the fuel system by holding the control switch at **STOP/PRIME** for 30 seconds. (The status indicator light will stay on solid while the pump is on.)

### 3.3 Starting the Genset

Start the genset from the genset control panel or remote control panel inside the vehicle (See [Section 2.7 on page 9](#)).

1. Push and hold the switch at **START** until the genset starts. The status indicator light on the switch flashes while cranking. It will come on solid when the starter disconnects, indicating that the genset is running.
2. The genset control will discontinue cranking if the genset does not start within 30 seconds and will cause the status indicator light to blink Fault Code No. 4. Wait 5 seconds for the control to reset before trying again. See [Chapter 5 on page 27](#) if the genset does not start after two or three tries.



**CAUTION:** *Do not risk burning out the starter motor by continued attempts to start. Find out why the genset is not starting and repair as necessary.*

3. For top performance and engine life, especially in colder weather, let the engine warm up for two minutes before connecting appliances.
4. Check for fuel and exhaust leaks. Stop the genset immediately if there is a fuel or exhaust leak and have it repaired.
5. See [on page 27](#) if the engine shuts down and the status indicator light blinks.
6. Always secure the access cover after starting the genset at the genset control panel.



**WARNING:** *Operating the genset with the access cover off can lead to severe burns and overheating of components. Always secure the cover after starting the genset.*

### 3.4 Stopping the Genset

Turn off the air conditioner and other large appliances and let the genset run for two minutes to cool down before stopping. This reduces backfiring and run-on. Then press the switch to **STOP** to stop the genset.

### 3.5 Restarting the Genset

See [Chapter 5 on page 27](#) if the genset shuts down abnormally.

### 3.6 Engine Run Only Operation

Shutdowns due to an alternator failure can be bypassed when the generator set is restarted within one (1) minute of shutting down. While operating in this mode, the engine will run but the generator set will not create an AC output. The status indicator lamp flashes at a high frequency while operating in this mode. This feature allows the engine's hydraulic pump (optional) to run so that hydraulic systems powered by the engine can be operated though AC output has failed.

## 3.7 Loading the Genset

The genset can power AC motors, air conditioners, AC/DC converters and other appliances. How much appliance load\* can be powered depends upon the genset power rating. The genset will shut down or its circuit breakers will trip if the sum of the loads exceeds genset power.

To avoid overloading the genset and causing shutdowns, compare the sum of the loads of the appliances that are likely to be used at the same time with the power rating of the genset. Use [Table 2](#) or the ratings on the appliances themselves (if so marked) to obtain the individual appliance loads. ***It may be necessary to run fewer appliances at the same time—the sum of the loads must not be greater than genset rating.***

Note that the genset may shut down due to overload—even though the sum of the loads is less than genset rating—when a large motor or air conditioner is started last or cycles off and then on again. The reason for this is that a motor's startup load is much larger than its running load. ***It may be necessary to run fewer appliances when large motors and air conditioners are cycling on and off.***

TABLE 2. TYPICAL APPLIANCE LOADS

Appliance	Load (watts)
Air Conditioner	1400-2000
Battery Charger	Up to 3000
DC Converter	300-700
Refrigerator	600-1000
Microwave Oven	1000-1500
Electric Frying Pan or Wok	1000-1500
Electric Stove Element	350-1000
Electric Water Heater	1000-1500
Electric Iron	500-1200
Electric Hair Dryer	800-1500
Coffee Percolator	550-750
Television	200-600
Radio	50-200
Electric Drill	250-750
Electric Broom	200-500
Electric Blanket	50-200

Note also that air density decreases as altitude increases, causing rated genset engine power to decrease—approximately 3.5 percent each increase of 1000 feet (305 m) ([Table 3](#)). ***It may be necessary to run fewer appliances at higher altitudes.***

De-rating for temperature usually is not necessary because the engine can maintain rated power in ambient air temperatures of up to 120° F (49° C).

TABLE 3. POWER VS. ALTITUDE

Genset Rated 7.0 kW <sup>1</sup>	Genset Rated 6.5 kW <sup>1</sup>	Genset Rated 5.5 kW <sup>1</sup>
7000 watts up to 3000 ft (914 m)	6500 watts up to 3000 ft (914 m)	5500 watts up to 3000 ft (1524 m)
6755 watts @ 4000 ft (1219 m)	6272 watts @ 4000 ft (1219 m)	5500 watts @ 4000 ft (1829 m)
6510 watts @ 5000 ft (1524 m)	6044 watts @ 5000 ft (1524 m)	5500 watts @ 5000 ft (2134 m)
1. - This table does not take into account the effect circuit breakers may have in limiting maximum genset power. Also, power decreases even though the altitude adjust knob is set correctly ( <a href="#">Section 3.12</a> ).		

\* Appliance load and genset power are measured in terms of watts (W) or kilowatts (kW), where 1 kilowatt (kW) = 1000 watts (W).

### 3.8 Resetting Circuit Breakers

If a circuit breaker in the main power distribution panel of the vehicle or on the genset ([Figure 7](#)) trips, either a circuit shorted or too many appliances were running. Note that the genset may continue to run after a circuit breaker trips.

If a circuit breaker trips, disconnect or turn off as many loads as possible and reset the circuit breaker. (Push the circuit breaker to **OFF** to reset it and then to **ON** to reconnect the circuit.) If the circuit breaker trips right away, either the electrical distribution system has a short circuit or the circuit breaker is faulty. Call a qualified electrician.

If the circuit breaker does not trip, reconnect the appliances, one by one, up to a total load that does not overload the genset or cause the circuit breaker to trip. If a circuit breaker trips right away when an appliance is connected, the appliance probably has a short.

Electrical appliances and tools must be used and maintained properly and be properly grounded to cause the line circuit breakers to trip when short circuits occur.



**WARNING:** *Short circuits in electrical appliances and tools can cause fire and electrical shock leading to severe personal injury or death. Read and follow the equipment and tool manufacturer's instructions and warnings regarding use, maintenance and proper grounding.*

### 3.9 Connecting Utility Power

A vehicle with provisions for connecting utility power must have an approved device to keep the genset and utility from being interconnected. See the genset Installation Manual for more information.



**WARNING:** *Interconnecting the genset and the public utility (or any other power source) can lead to electrocution of utility line workers, equipment damage and fire. Use an approved switching device to prevent interconnections.*

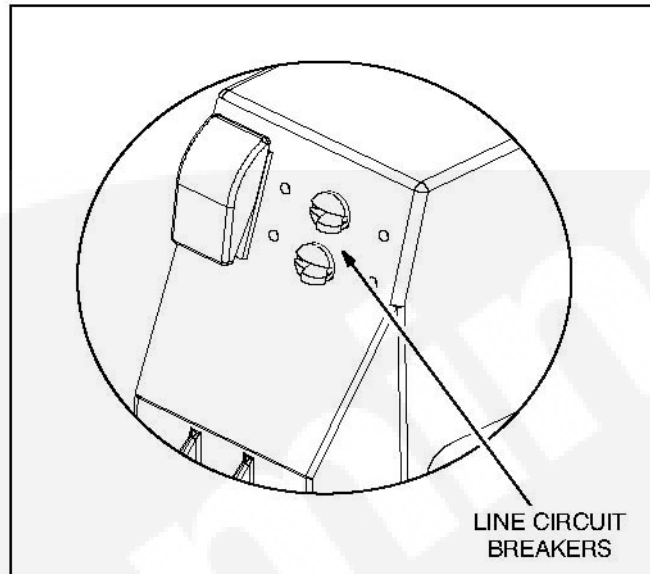

**FIGURE 7. LINE CIRCUIT BREAKER**

### 3.10 Operating in Cold Weather

Pay particular attention to the following items when operating the genset in cold weather:

1. Make sure engine oil viscosity is appropriate for the ambient temperatures. Change oil if there is a sudden drop in temperature. See [Section 2.5 on page 8](#).
2. Perform spark plug maintenance (See [Section 4.6 on page 24](#)).
3. Perform battery maintenance (See [Section 4.4 on page 23](#)).
4. If so equipped, reset the carburetor for altitude ( [Figure 8](#) ).

### 3.11 Operating in Hot Weather

Pay particular attention to the following items when operating the genset in hot weather:

1. Make sure nothing blocks airflow to and from the genset.
2. Make sure engine oil viscosity is appropriate for the ambient temperatures. See [Section 2.5 on page 8](#).
3. Keep the genset clean.
4. Perform maintenance due. See [Chapter 4 on page 19](#).
5. If so equipped, reset the carburetor for altitude ([Figure 8](#)).

### 3.12 Operating at High Altitude

**Series HGJAB Only** - For best fuel economy and genset operation between 0 and 5,000 feet, reset the carburetor for the current altitude ([Figure 8](#)). Altitude may be found on road maps and road signs. For the effect of altitude on maximum power, see LOADING THE GENSET ([Section 3.7](#)).



**CAUTION:** Operating the genset at low altitude with a high altitude setting can cause power loss, overheating and engine damage. Always reset when returning to lower altitudes.

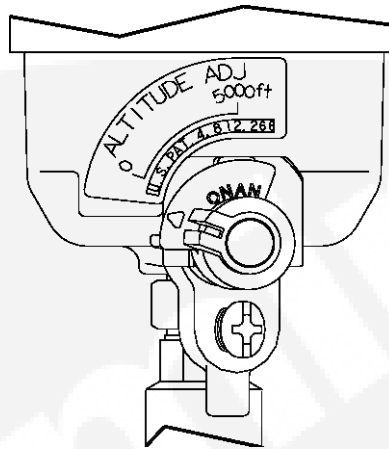

**FIGURE 8. ALTITUDE ADJUST KNOB (SERIES HGJAB GASOLINE ONLY)**

To remain emissions compliant while operating above 5,000 feet for an extended period of time, a high altitude kit is required. Extended operation above 5,000 feet without the high altitude kit may increase emissions and decrease fuel economy and performance. Operation of this generator below 5,000 feet with the high altitude kit may also increase emissions. This generator, when operated above 5,000 feet with the high altitude kit installed, will meet each emission standard throughout its useful life. See a Cummins distributor or service provider for information regarding this high altitude kit.

### 3.13 Operating in Dusty Environments

Pay particular attention to the following items when operating the genset in dusty environments:

1. Do not let dirt and debris accumulate inside the genset compartment. Keep the genset clean.
2. Perform air cleaner maintenance more often (See [Section 4.5 on page 23](#)).
3. Change engine oil every 50 hours.
4. Keep containers of engine oil that have been opened tightly closed to keep out dust.

### 3.14 Breaking in a New Engine

Proper engine break-in on a new genset or on one with a rebuilt engine is essential for top engine performance and acceptable oil consumption. Run the genset at approximately 1/2 rated power for the first 1 hour and then at 3/4 rated power for 1 more hour. See **LOADING THE GENSET** ([Section 3.7](#)).

Proper engine oil and oil level are especially critical during break-in because of the higher engine temperatures that can be expected. Change the oil if not appropriate for the ambient temperatures during break-in. See **ENGINE OIL RECOMMENDATIONS** ([Section 2.5](#)). Check oil level twice a day or every 4 hours during the first 20 hours of operation and change the oil after the first 20 hours of operation.

## 3.15 Exercising the Genset

Exercise the genset at least 1 hour each month if use is infrequent. Run the genset at approximately 1/2 rated power. See **LOADING THE GENSET**([Section 3.7](#)). A single exercise period is better than several shorter periods.

Exercising a genset drives off moisture, re-lubricates the engine, replaces stale fuel in fuel lines and carburetor and removes oxides from electrical contacts and generator slip rings. The result is better starting, more reliable operation and longer engine life.

## 3.16 Storing the Genset

Proper storage is essential for preserving top genset performance and reliability when the genset cannot be exercised regularly and will be idle for more than 120 days.

### 3.16.1 Storing Genset

1. **Gasoline Models Only** - Fill the fuel tank with fresh fuel and add a fuel preservative (OnaFresh™), following the instructions on the container label. Unless a preservative (stabilizer) is added, the gasoline in the fuel system will deteriorate causing fuel system corrosion, gum formation and varnish-like deposits which can lead to hard starting and rough operation.
2. Then run the genset for about 30 minutes at approximately 1/2 rated power to fill the fuel lines with the fresh fuel and preservative.





**WARNING:** *Gasoline preservatives (stabilizers) are toxic. Follow the instructions on the container. Avoid skin contact. Wash hands with soap and water after using.*

3. Change the engine oil (See [Section 4.3 on page 22](#)) and attach a tag indicating grade of oil viscosity (See [Section 2.5 on page 8](#)).
4. Remove the air filter (See [Section 4.5 on page 23](#)) and restart the genset. While the genset is running, spray an engine fogger (OnaGard™) into the carburetor, following the instructions on the container label, and stop the genset. The fogger leaves a protective coat of oil on the internal surfaces of the engine.
5. **LPG Models** - Check the local ordinances if the vehicle is to be garaged. Generally, ordinances require that the LPG system be leak-free, that the LPG container not be filled beyond specified limits, that the container shutoff valve be closed and that the vehicle not be parked near sources of heat or ignition.

### 3.16.2 Returning Genset to Service

1. Check the oil tag on the genset and change the oil if the viscosity indicated is not appropriate for the temperatures expected. See [Section 2.5 on page 8](#).
2. Reconnect the starting battery (negative [-] cable last). See [Section 4.4 on page 23](#).
3. Remove the plug from the exhaust tailpipe.
4. Change the air filter element if it is dirty (See [Section 4.5 on page 23](#) ).
5. Open the fuel supply valve (if so equipped).
6. Inspect the genset. See [Section 4.1 on page 19](#).

- 
7. **Gasoline Models** - Prime the genset fuel system by holding the control switch at **STOP/PRIME** for 30 seconds. (The status indicator light will stay on solid while the pump is on.)
  8. Start the genset. There may be smoke and rough operation for a few minutes until the oil from the fogger burns off. If the engine does not start, clean or replace the spark plugs, which may have been fouled by the fogger.
  9. Push the genset line circuit breaker ON (See [Section 3.8 on page 14](#)) when the genset is ready to power appliances.
- 
- 

# 4 Periodic Maintenance

Periodic maintenance is essential for top performance and long genset life. Use [Table 4](#) as a guide for normal periodic maintenance. In hot and dusty environments some maintenance procedures should be performed more frequently, as indicated by the footnotes in the table. Keeping a log of maintenance performed and hours run will help you keep genset maintenance regular and provide a basis for supporting warranty claims (See [Chapter 9 on page 41](#) ).

Maintenance, replacement or repair of emission control devices and systems may be performed by any engine repair establishment or individual. However, warranty work must be completed by an authorized Onan dealer.

**TABLE 4. PERIODIC MAINTENANCE SCHEDULE**

MAINTENANCE PROCEDURE	MAINTENANCE FREQUENCY						
	Every Day or Every 8 Hours	After First 20 Hours	Every Month	Every 50 Hours	Every 150 Hours	Every 450 Hours	Every 500 Hours
General Inspections	X						
Check Engine Oil Level	X						
Clean and Check Battery			X <sup>3</sup>				
Clean Spark Arrestor				X			
Change Engine Oil & Oil Filter		X <sup>1</sup>			X <sup>2, 3, 4</sup>		
Replace Air Filter Element					X <sup>2</sup>		
Replace Spark Plugs							X <sup>5</sup>
Clean Engine Cooling Fins							X <sup>2</sup>
Replace Fuel Filter							X <sup>5, 6</sup>
Adjust Valve Lash							X <sup>6</sup>
Clean or Replace Cylinder Heads						X <sup>6, 7</sup>	

1 - As a part of engine break-in, change the engine oil after the first 20 hours of operation.  
 2 - Perform more often when operating in dusty environments.  
 3 - Perform more often when operating in hot weather.  
 4 - Perform at least once a year.  
 5 - Perform sooner if engine performance deteriorates.  
 6 - Must be performed by a qualified mechanic (authorized Onan dealer).  
 7 - Must be completed for optimum performance.

## 4.1 Conducting General inspections

Inspect the genset before the first start of the day and after every eight hours of operation.

### 4.1.1 Oil Level

Check engine oil level ([Section 4.2](#)).

## 4.1.2 Exhaust System



**WARNING:** *Beginning with Spec J, EPA Phase 3 and CARB Tier 3 product incorporates a catalyst which leads to subsequent higher exhaust gas temperatures. Due to higher exhaust gas temperatures, the installer must review and follow all guidelines for tail-pipe installations, shielding and surround material requirement for compatibility.*

Look and listen for exhaust system leaks while the genset is running. Shut down the genset if a leak is found and have it repaired before operating the genset again.

Look for openings or holes between the genset compartment and vehicle cab or living space if the genset engine sounds louder than usual. Have all such openings or holes closed off or sealed to prevent exhaust gases from entering the vehicle.

Replace dented, bent or severely rusted sections of the tailpipe and make sure the tailpipe extends at least 1 inch (25.4 mm) beyond the perimeter of the vehicle.

Park the vehicle so that genset exhaust gases disperse away from the vehicle. Barriers such as walls, snow banks, high grass and brush and other vehicles can cause exhaust gases to accumulate in and around the vehicle.

Do not operate power ventilators or exhaust fans while the vehicle is standing with the genset running. The ventilator or fan can draw exhaust gases into the vehicle.

Check all CO monitors to assure proper operation.



**WARNING:** *EXHAUST GAS IS DEADLY! Do not operate the genset if there is an exhaust leak or any danger of exhaust gases entering or being drawn into the vehicle.*



**WARNING:** *Do not park the vehicle in high grass or brush. Contact with the exhaust system can cause a fire.*

## 4.1.3 Fuel System

Check for leaks at the hose, tube and pipe fittings in the fuel supply and return systems while the genset is running and while it is stopped. *Do not use a flame to check for LPG leaks.* Check flexible fuel hose sections for cuts, cracks, and abrasions. Make sure the fuel line is not rubbing against other parts. Replace worn or damaged fuel line parts before leaks occur.

If you smell gas, close the LPG container shutoff valve and have the genset serviced before using it again.



**WARNING:** *Gasoline and LPG are highly flammable and explosive and can cause severe personal injury or death. Shut down the genset and repair leaks immediately.*

## 4.1.4 Battery Connections

Check the battery terminals for clean, tight connections. Loose or corroded connections have high electrical resistance which makes starting harder. See MAINTAINING THE BATTERY AND BATTERY CONNECTIONS ([Section 4.4](#)).



**WARNING:** *Arcing at battery terminals or light switch or other equipment or flames and sparks can ignite battery gas causing severe personal injury—Ventilate battery area before working on or near battery—Wear safety glasses—Do not smoke—Switch trouble light ON / OFF away from battery—Do not disconnect battery cables while genset is running or vehicle battery charging system is on—Always disconnect negative (-) cable first and reconnect it last.*

## 4.1.5 Mechanical

Look for mechanical damage. Start the genset and look, listen and feel for any unusual noises and vibrations.

Check the genset mounting bolts to make sure they are secure.

Check to see that the genset air inlet and outlet openings are not clogged with debris or blocked.

Clean accumulated dust and dirt from the genset. Do not clean the genset while it is running or still hot. Protect the generator, air cleaner, control panel, and electrical connections from water, soap and cleaning solvents.



**WARNING:** *Always wear safety glasses when using compressed air, a pressure washer or a steam cleaner to avoid severe eye injury.*

## 4.2 Checking Engine Oil Level

Park the vehicle on level ground and shut off the genset before checking the engine oil level.



**WARNING:** *Crankcase pressure can blow hot engine oil out the fill opening causing severe burns. Always stop the genset before removing the oil fill cap.*

1. Unscrew the oil fill cap and wipe oil off the dipstick ([Figure 9](#)). Screw the cap back on, remove it and check the oil level on the dip stick.
2. Add or drain oil as necessary. See ENGINE OIL RECOMMENDATIONS ([Section 2.5](#)). Keep the oil level between the FULL and ADD marks.



**CAUTION:** *Too much oil can cause high oil consumption. Too little oil can cause severe engine damage. Keep the oil level between the Full and Add marks.*

**OIL FILLS VERY SLOWLY. TAKE YOUR TIME AND CHECK LEVEL OFTEN WHILE FILLING. IT TAKES TIME FOR THE AIR IN THE CRANKCASE TO ESCAPE AND ALLOW OIL TO ENTER.**

3. Screw the oil fill cap back on securely.

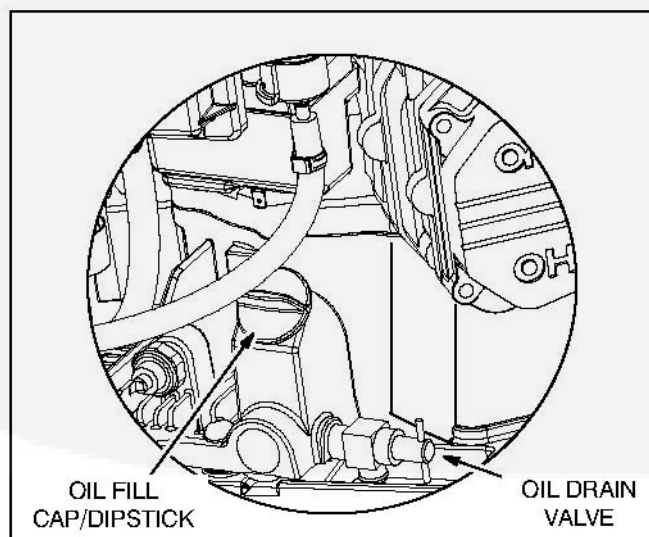

**FIGURE 9. OIL FILL/DIPSTICK AND DRAIN VALVE**

## 4.3 Changing Engine Oil and Oil Filter



**WARNING:** *State and federal agencies have determined that contact with used engine oil can cause cancer or reproductive toxicity. Try to avoid skin contact and breathing of vapors. Use rubber gloves and wash exposed skin.*

Refer to [Table 4](#) for scheduled engine oil change. Change oil more often in hot or dusty environments.

1. Place a pan underneath the oil drain hose and filter ([Figure 10](#)). Run and then stop the engine when it is warm.



**WARNING:** *Crankcase pressure can blow hot engine oil out the fill opening causing severe burns. Always stop the genset before removing the oil fill cap.*

2. Remove the oil fill cap, open the oil drain valve ([Figure 9](#)), let all oil drain from the engine and then close the drain valve.
3. **High Pressure LPG Gensets:** Drain the LPG system of accumulated oil ([Section 3.16.1](#)).
4. Spin off the old oil filter and thoroughly wipe off the filter mounting surface. Remove the old gasket if it does not come off with the filter.
5. Apply a film of oil to the filter gasket and spin the new filter on by hand until the gasket just touches the mounting pad. Then turn it 1/2 to 3/4 turn—not more.
6. Refill with 2 quarts (1.8 l) of oil. See ENGINE OIL RECOMMENDATIONS ([Section 2.5](#)). Check and add or drain oil as necessary.



**CAUTION:** *Too much oil can cause high oil consumption. Too little oil can cause severe engine damage. Keep the oil level between the Full and Add marks.*

*OIL FILLS VERY SLOWLY. TAKE YOUR TIME AND CHECK LEVEL OFTEN WHILE FILLING. IT TAKES TIME FOR THE AIR IN THE CRANKCASE TO ESCAPE AND ALLOW OIL TO ENTER.*

7. Dispose of the used oil and oil filter in accordance with local environmental regulations.

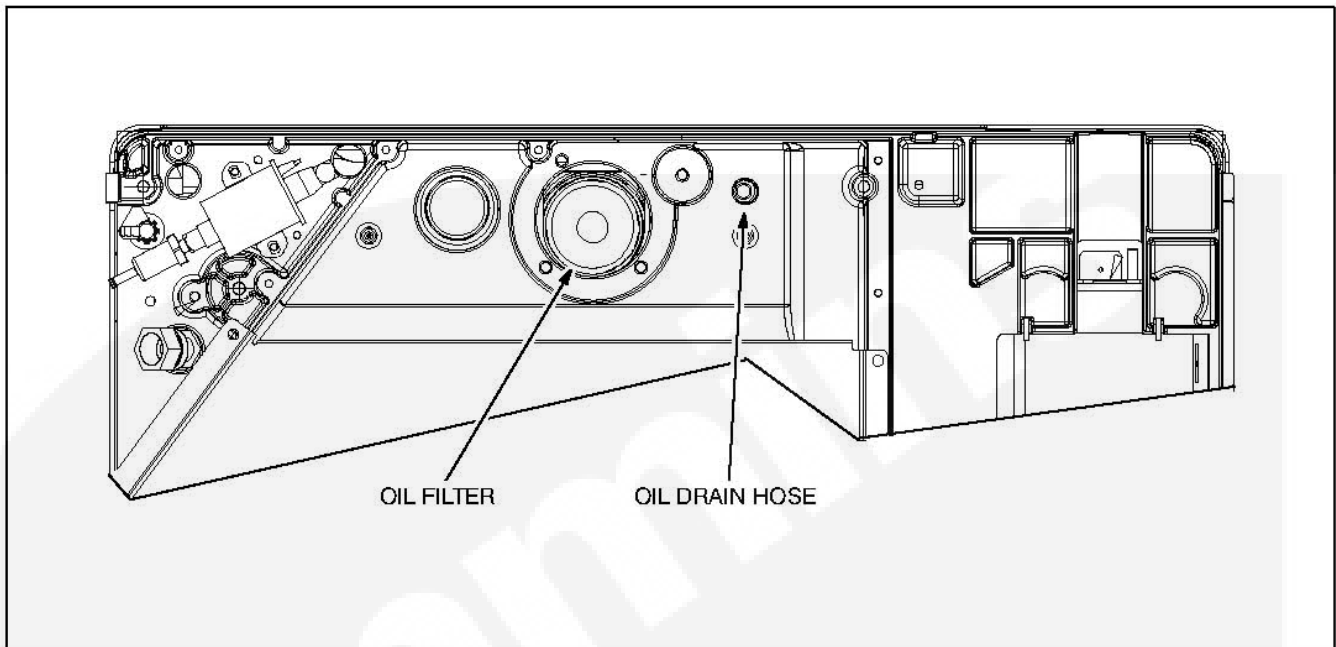

FIGURE 10. OIL FILTER AND DRAIN HOSE—VIEW FROM BELOW OF FRONT EDGE OF GENSET

## 4.4 Maintaining Battery and Battery Connections



**WARNING:** *Arcing at battery terminals or light switch or other equipment or flames and sparks can ignite battery gas causing severe personal injury—Ventilate battery area before working on or near battery—Wear safety glasses—Do not smoke—Switch trouble light ON / OFF away from battery—Do not disconnect battery cables while genset is running or vehicle battery charging system is on—Always disconnect negative (-) cable first and reconnect it last.*

Refer to [Table 4](#) for scheduled battery maintenance, and follow the battery manufacturer's instructions. Have the battery charging system serviced if DC system voltage is consistently low or high. Always:

1. Keep the battery case and terminals clean and dry and the terminals tight.
2. Remove battery cables with a battery terminal puller.
3. Make sure which terminal is positive (+) and which is negative (-) before making battery connections, always removing the negative (-) cable first and reconnecting it last to reduce arcing.

## 4.5 Replacing the Air Filter Element

Refer to [Table 4](#) for scheduled air filter element replacement. In dusty environments the filter element should be inspected and changed more frequently. To change the filter element ([Figure 11](#)):

1. Unlatch the three spring clips and rotate the cover out and away from the hooks on top. Remove the air filter element.
2. Wipe the filter element sealing surfaces clean and reassemble the air filter with a new filter element.

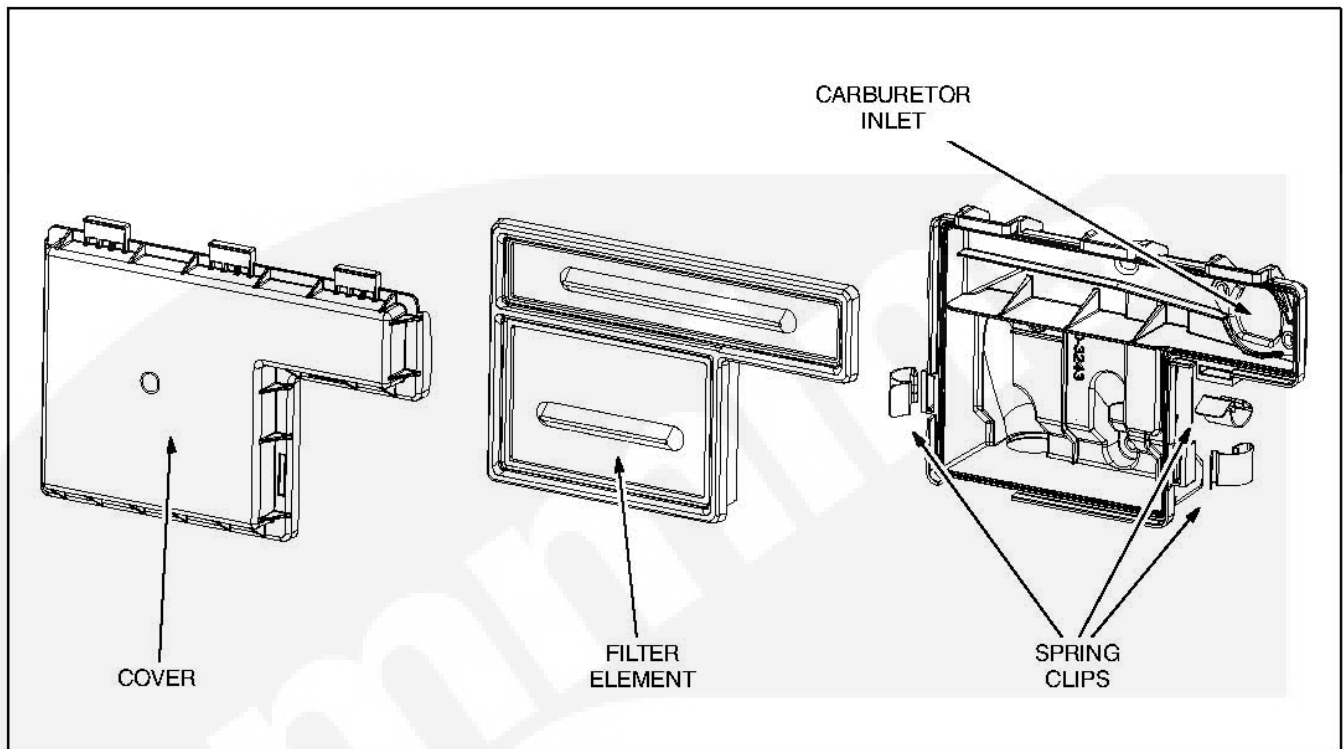

FIGURE 11. REPLACING THE AIR FILTER ELEMENT

## 4.6 Replacing Spark Plugs

Refer to [Table 4](#) for scheduled spark plug replacement. (The genset has two spark plugs, [Figure 12](#).) The spark plugs must be in good condition for proper engine starting and performance. A spark plug that fouls frequently or has heavy soot deposits indicates the need for engine service. See *Troubleshooting* ([Chapter 5](#)).

To prevent cross threading, always thread a spark plug in by hand until it seats and then torque to 10 lbs-ft (13 N-m).

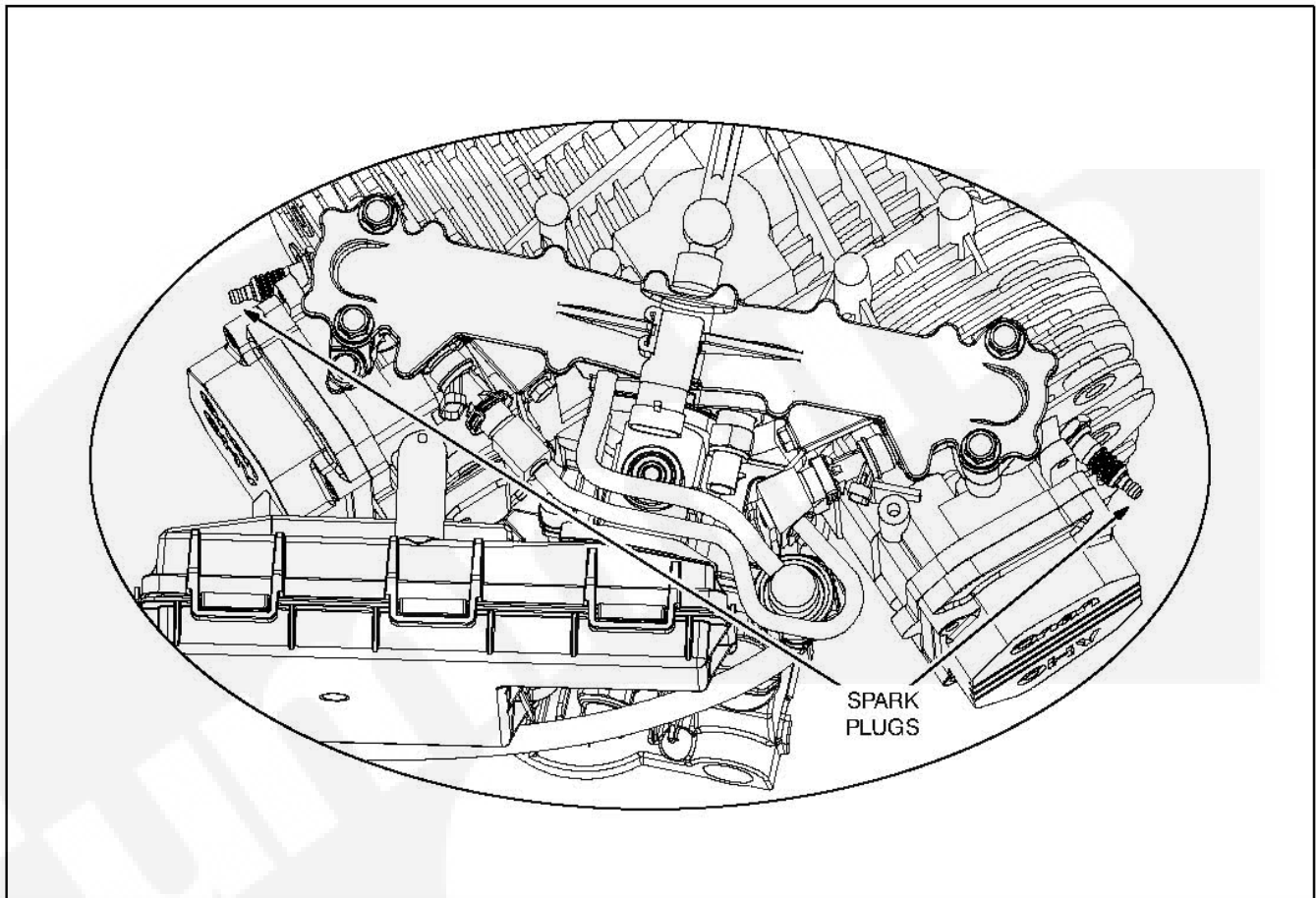

FIGURE 12. SPARK PLUGS

## 4.7 Cleaning the Spark Arrestor

Refer to [Table 4](#) for scheduled cleaning of the spark arrestor muffler. Cleaning is required for maximum genset performance. *Park the vehicle away from grass, brush or debris that could be ignited by sparks expelled during this procedure.*



**WARNING:** A hot muffler can cause severe burns. Let the muffler cool down before removing or installing cleanout plugs or screens.

**Series HGJAA:** A muffler is mounted inside the genset. The cleanout plug is in the drum, but accessible from below, though not readily visible. In [Figure 13](#) a portion of the lower drum is cut out so that the location of the plug is visible.

1. Locate the square-headed cleanout plug by hand and solidly seat a 7/16 inch, *eight point*, 3/8 inch drive socket wrench with 3 inch extension on the plug. Then add a swivel section and 6 inch extension and turn with a ratchet to remove the plug.
2. Start and load the genset to near full power ([Section 3.7](#)). Let the genset run for about five minutes to expel the soot in the muffler.
3. Stop the genset, allow the muffler to cool down and then reinstall the plug.

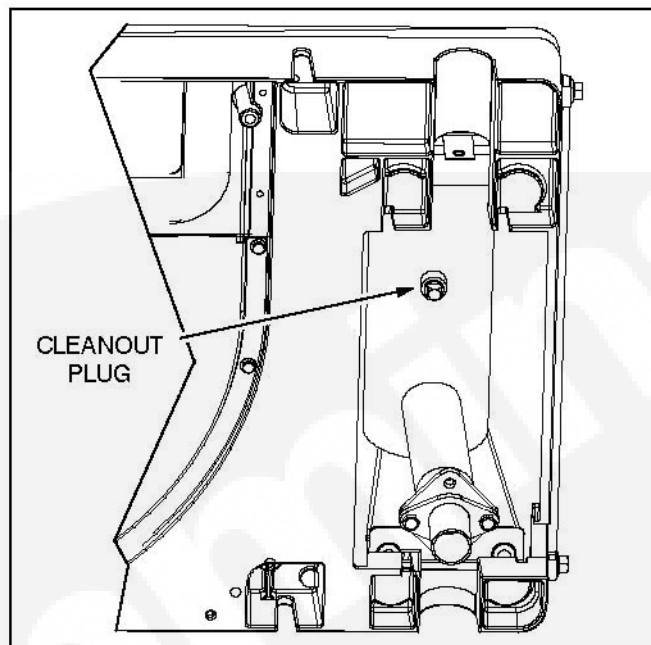

**FIGURE 13. MUFFLER CLEANOUT PLUG—VIEW FROM BELOW**

# 5 Troubleshooting

---



**WARNING:** *Hot engine parts can cause severe burns. Always allow the engine time to cool before performing any maintenance or service.*

[Table 5](#) TROUBLESHOOTING lists the Fault Codes in numerical order along with step-by-step corrective actions. If you are unable to resolve the problem after taking the corrective actions suggested, contact an authorized Onan dealer. See *How to Obtain Service* (Page [Chapter 8](#)).

First note the following:

- Maintaining engine oil level, keeping battery connections clean and tight, watching the fuel gauge, not overloading the genset, etc. will prevent most shutdowns.
- When the genset and vehicle engine share a common fuel tank the fuel dip tubes are usually arranged so that the genset will run out of fuel first. Marking the genset empty point on the fuel gauge will make it easier to tell when to stop the genset before running it out of fuel.

## 5.1 Fault Codes

The genset controller provides extensive diagnostics by causing the status indicator light on the Control Switch to blink in a coded fashion. Following a fault shutdown, the indicator light will repeatedly blink 2, 3 or 4 blinks at a time.

- **Two blinks** indicates a low oil pressure fault.
- **Three blinks** indicates a service fault. Press **Stop** once to cause the two-digit, second-level fault code to blink. (Pressing **Stop** again will stop the blinking.) The two-digit code consists of 1, 2, 3, 4 or 5 blinks, a brief pause, and then 1 to 9 blinks. The first set of blinks represents the tens digit and the second set of blinks the units digit of the fault code number. For example, **Fault Code No. 36** appears as:

blink-blink-blink—*pause*—blink-blink-blink-blink-blink-blink—*long pause*—repeat

- **Four blinks** indicates that cranking exceeded 30 seconds without the engine starting.
- Flashing at high frequency - Generator set is operating in Engine Run Only (ERO) mode. AC output is disabled.
- **Note: Fault Code Nos. 3 and 4 are first level faults. Avoid interpreting them as second-level Fault Code Nos. 33 and 44, which have not been assigned as fault codes.**

**Restoring Fault Code Blinking** - The fault code stops blinking after five minutes (15 minutes, Series HGJAA). Press **Stop** three times within five seconds to restore blinking. **Note that the last fault logged will blink, even after the condition that caused the shutdown has been corrected.**

TABLE 5. TROUBLESHOOTING

 <b>WARNING:</b> <i>Some genset service procedures present hazards that can result in severe personal injury or death. Only trained and experienced service personnel with knowledge of fuels, electricity, and machinery hazards should perform genset service. See Safety Precautions.</i>
<b>STATUS INDICATOR LIGHT DEAD</b> (Faulty connections, no battery voltage)
<b>Corrective Action:</b> <ol style="list-style-type: none"> <li>1. Try the genset Start Switch if the remote Start Switch does not work, and vice versa.</li> <li>2. Clean and tighten the positive (+) and negative (-) battery cable connections at the battery, vehicle frame and genset.</li> <li>3. Recharge or replace the battery. Refer to the battery manufacturer's recommendations.</li> </ol>
<b>STARTING BATTERIES RUN DOWN</b> (Marginal batteries, connections, or charging system or, parasitic loads)
<b>Corrective Action:</b> <ol style="list-style-type: none"> <li>1. Clean and tighten the positive (+) and negative (-) battery cable connections at the battery, vehicle frame and genset.</li> <li>2. Recharge or replace the battery. Refer to the battery manufacturer's recommendations.</li> <li>3. Have a battery charging system installed or serviced in the vehicle.</li> </ol>
<b>STARTER ENGAGES-DISENGAGES</b> (Cranking voltage dips below 6 volts—low battery charge, poor connections, long cables)
<b>Corrective Action:</b> <ol style="list-style-type: none"> <li>1. Have the vehicle propulsion engine running while trying to start the genset—the battery charging alternator may be able to maintain starting voltage high enough to get the genset started.</li> <li>2. Clean and tighten the positive (+) and negative (-) battery cable connections at the battery, vehicle frame and genset.</li> <li>3. Recharge or replace the battery. Refer to the battery manufacturer's recommendations.</li> <li>4. Increase battery cable size or run parallel cables.</li> </ol>
<b>NO AC POWER—GENSET RUNNING, STATUS LIGHT ON</b> (Line circuit breaker OFF, or tripped due to short circuit or overload)
<b>Corrective Action:</b> <ol style="list-style-type: none"> <li>1. Turn on or reset the line circuit breaker on the genset (<a href="#">Section 3.8</a>).</li> <li>2. Turn on or reset the line circuit breakers on the main distribution panel in the vehicle.</li> </ol>
<b>NO AC POWER—GENSET RUNNING, STATUS LIGHT FLASHING RAPIDLY</b> (Genset operating in Engine Run Only (ERO) mode due to faulty generator, see section <a href="#">Section 3.6</a> )
<b>Corrective Action:</b> See an authorized Onan dealer.
<b>LOW OIL PRESSURE FAULT—CODE NO. 2</b> (First-level fault code—Low oil pressure cutoff switch did not open)
<b>Corrective Action:</b> <ol style="list-style-type: none"> <li>1. Check engine oil level and add oil as necessary (<a href="#">Section 4.2</a>).</li> <li>2. Drain excess oil (above dipstick Full mark.)</li> </ol>
<b>SERVICE CHECK FAULT—CODE NO. 3</b> (First-level fault code—Indicates fault with second-level fault code)



**WARNING:** *Some genset service procedures present hazards that can result in severe personal injury or death. Only trained and experienced service personnel with knowledge of fuels, electricity, and machinery hazards should perform genset service. See Safety Precautions.*

**Corrective Action:** Check the second-level fault code by pressing **STOP** once. The second-level fault code will have two-digits. The faults are listed in numerical order in this table.

**OVERCRANK FAULT—CODE NO. 4**

(First-level fault code—Cranking exceeded 30 seconds without engine starting)

**Corrective Action:**

1. **Gasoline Models** -Check and fill the fuel tank, as necessary. (Note: The genset fuel pickup tube is probably higher up in the fuel tank than the vehicle engine pickup.)
2. Prime the engine fuel system by holding the control switch at **Stop/Prime** for 30 seconds.
3. **Low Pressure LPG Models** - Check and fill the LPG container, as necessary. *On cold days the LPG container may have to be kept at least half full to provide the rate of vaporization necessary to keep up with the genset fuel demand.*
4. **High Pressure LPG Models** - Check and fill the LPG container, as necessary, and drain the genset LPG system of oil that may have migrated from the supply system ([Section 3.16.1 on page 17](#)). *Make sure to re-close the drain valve.*
5. Open any closed fuel valves.
6. Secure the spark plug leads on the spark plugs ([Section 4.6](#)).
7. Replace the spark plugs ([Section 4.6](#)).
8. Service the air cleaner ([Section 4.5](#)).

**OVERVOLTAGE FAULT—CODE NO. 12**

(Controller unable to maintain rated voltage)

**Corrective Action:** See an authorized Onan dealer.

**UNDERVOLTAGE FAULT—CODE NO. 13**

(Controller unable to maintain rated voltage)

**Corrective Action:** Reduce the number of connected appliances, especially when air conditioners and battery chargers are running.

**OVERFREQUENCY FAULT—CODE NO. 14**

(Engine governor unable to maintain rated frequency)

**Corrective Action:** See an authorized Onan dealer.

**UNDERFREQUENCY FAULT—CODE NO. 15**

(Engine governor unable to maintain rated frequency)

**Corrective Action:**

1. Reduce the number of connected appliances, especially when air conditioners and battery chargers are running.
2. **High Pressure LPG Models** - Drain the genset LPG system of oil that may have migrated from the supply system ([Section 3.16.1 on page 17](#)). *Make sure to re-close the drain valve.*

**GOVERNOR ACTUATOR FAULT—CODE NO. 19**

(Controller sensed open or shorted circuit)

**Corrective Action:** See an authorized Onan dealer.

**GOVERNOR ACTUATOR OVERLOAD FAULT—CODE NO. 22**

(Duration of operation at or near full-duty cycle beyond design limit)



**WARNING:** *Some genset service procedures present hazards that can result in severe personal injury or death. Only trained and experienced service personnel with knowledge of fuels, electricity, and machinery hazards should perform genset service. See Safety Precautions.*

**Corrective Action:**

1. Reduce the number of connected appliances, especially when air conditioners and battery chargers are running.
2. Service the air cleaner ([Section 4.5](#)).
3. Check for and repair a blocked exhaust system.

**LOW OIL PRESSURE CUTOFF SWITCH FAULT—CODE NO. 23**  
(Controller sensed switch still open during start—not a running fault)

**Corrective Action:** See an authorized Onan dealer.

**VOLTAGE SENSE FAULT—CODE NO. 27**  
(Controller unable to sense output voltage)

**Corrective Action:** See an authorized Onan dealer.

**HIGH BATTERY VOLTAGE FAULT—CODE NO. 29**  
(Voltage across battery system greater than 19 volts)

**Corrective Action:**

1. Check battery bank connections and reconnect if necessary so that the 12 volt batteries serving the genset are connected in parallel (12 volt) rather than in series (24 volt).
2. Select a lower battery boost charge rate.

**OVERSPEED FAULT—CODE NO. 31**  
(Engine speed greater than 3400 rpm)

**Corrective Action:** See an authorized Onan dealer.

**LOW CRANKING SPEED FAULT—CODE NO. 32**  
(Cranking speed less than 180 rpm for more than 2 seconds)

**Corrective Action:**

1. Clean and tighten the positive (+) and negative (-) battery cable connections at the battery and at the genset.
2. Recharge or replace the battery. Refer to the battery manufacturer's recommendations.
3. Replace engine oil with oil of proper viscosity for ambient temperatures ([Section 2.5](#)). (High oil viscosity can slow down cranking speed.)

**CONTROL CARD FAILURE FAULT—CODE NO. 35**  
(Microprocessor EEPROM error during self-test)

**Corrective Action:** See an authorized Onan dealer.

**ENGINE STOPPED FAULT—CODE NO. 36**  
(Engine stopped without command by controller)



**WARNING:** *Some genset service procedures present hazards that can result in severe personal injury or death. Only trained and experienced service personnel with knowledge of fuels, electricity, and machinery hazards should perform genset service. See Safety Precautions.*

**Corrective Action:**

1. **Gasoline Models** -Check and fill the fuel tank, as necessary. (Note: The genset fuel pickup tube is probably higher up in the fuel tank than the vehicle engine pickup.)
2. **Low Pressure LPG Models** - Check and fill the LPG container, as necessary. *On cold days the LPG container may have to be kept at least half full to provide the rate of vaporization necessary to keep up with the genset fuel demand.*
3. **High Pressure LPG Models** - Check and fill the LPG container, as necessary, and drain the genset LPG system of oil that may have migrated from the supply system ([Section 3.16.1](#)). *Make sure to re-close the drain valve.*
4. Secure the spark plug leads on the spark plugs ([Section 4.6](#)).
5. Replace the spark plugs ([Section 4.6](#)).
6. Service the air cleaner ([Section 4.5](#)).
7. Check for mechanical damage.

**INVALID GENSET CONFIGURATION FAULT—CODE NO. 37**  
(Wrong frequency/rpm ratio)

**Corrective Action:** See an authorized Onan dealer.

**OVERCURRENT (FIELD OVERLOAD) FAULT—CODE NO. 38**  
(Low power factor loads)

**Corrective Action:**

1. Reduce the number of appliances running at the same time, especially those with high motor starting loads such as air conditioners.
2. Have air conditioners and other appliances checked for proper operation. (A locked compressor rotor can cause very low power factor.)

**GENERATOR ROTOR FAULT—CODE NO. 41**  
(Controller unable to sense field or output voltage)

**Corrective Action:** See an authorized Onan dealer.

**PROCESSOR FAULT—CODE NO. 42**  
(Microprocessor ROM error during self-test)

**Corrective Action:** See an authorized Onan dealer.

**PROCESSOR FAULT—CODE NO. 43**  
(Microprocessor RAM error during self-test)

**Corrective Action:** See an authorized Onan dealer.

**SPEED SENSE FAULT—CODE NO. 45**  
(Controller unable to sense quadrature frequency)

**Corrective Action:** See an authorized Onan dealer.

**IGNITION FAULT—CODE NO. 47**  
(Controller unable to sense ignition)

**Corrective Action:** See an authorized Onan dealer.

**GENERATOR FIELD SENSE FAULT—CODE NO. 48**  
(Controller unable to sense field voltage)

**Corrective Action:** See an authorized Onan dealer.

 <b>WARNING:</b> <i>Some genset service procedures present hazards that can result in severe personal injury or death. Only trained and experienced service personnel with knowledge of fuels, electricity, and machinery hazards should perform genset service. See Safety Precautions.</i>
<b>PROCESSOR FAULT—CODE NO. 51</b> (Microprocessor malfunction)
<b>Corrective Action:</b> See an authorized Onan dealer.
<b>FUEL INJECTOR FAULT—CODE NO. 52</b> (Open or short circuit in fuel injector)
<b>Corrective Action:</b> See an authorized Onan dealer.
<b>MAT SENDER FAULT—CODE NO. 54</b> (Open or short circuit in MAT sender)
<b>Corrective Action:</b> See an authorized Onan dealer.
<b>MAP SENDER FAULT—CODE NO. 56</b> (Open or short circuit in MAP sender)
<b>Corrective Action:</b> See an authorized Onan dealer.
<b>OVERPRIME FAULT—CODE NO. 57</b> (Prime mode exceeded 3 minutes)
<b>Corrective Action:</b> Check for and remove any object that may be holding either control switch (remote or local) in the prime position.
<b>EXHAUST GAS TEMPERATURE SHUTDOWN—CODE NO. 58</b> (Exhaust gas temperature reach 650C (1202F) for 2 seconds when the set is running)
<b>Corrective Action:</b> See an authorized Onan dealer
<b>EXHAUST GAS TEMPERATURE SENSOR OPEN—CODE NO. 81</b> (While running, EGT temperature falls below 60C (140F) for 2 minutes - OR - if EGT temperature is not above 60C (140F) after 2 minutes from starting, set will shut down)
<b>Corrective Action:</b> See an authorized Onan dealer
<b>EXHAUST GAS TEMPERATURE SENSOR SHORTED—CODE NO. 82</b> (With the set running and/or startup - control reads 1000C (1832F) for 1 second)
<b>Corrective Action:</b> See an authorized Onan dealer

# 6 Specifications

	GASOLINE MODELS			
	7.0 HGJAA	7.0 HGJAB	5.5 HGJAA	5.5 HGJAB
<b>GENERATOR:</b> 2-Pole Revolving Field, 2-Bearing, Self-Excited, 1-Phase, Vertical Shaft, Capped Digital Voltage Regulation				
Power	7000 watts		5500 watts	
Frequency	60 Hertz		60 Hertz	
Voltage	120 volts		120 volts	
Current	58.3 amp		45.8 amp	
Speed	3600 rpm		3600 rpm	
<b>FUEL CONSUMPTION:</b>				
No load	0.43 gph (1.6 l/h)	0.43 gph (1.6 l/h)	0.34 gph (1.3 l/h)	0.35 gph (1.3 l/h)
Half load	0.70 gph (2.7 l/h)	0.73 gph (2.8 l/h)	0.58 gph (2.2 l/h)	0.60 gph (2.3 l/h)
Full load	1.13 gph (4.3 l/h)	1.22 gph (4.6 l/h)	0.89 gph (3.4 l/h)	0.95 gph (3.6 l/h)
<b>ENGINE:</b> Air-Cooled, 4-Cycle Spark-Ignited, OHV, 90° V Twin Cyl, Vertical Shaft				
Fueling Method	SFI <sup>1</sup>	Carburetor	SFI <sup>1</sup>	Carburetor
Governor	Digital	Mechanical	Digital	Mechanical
Speed	2880 rpm		2400 rpm	
Bore	3.15 in (80 mm)		3.15 in (80 mm)	
Stroke	2.56 in (65 mm)		2.56 in (65 mm)	
Displacement	39.8 in <sup>3</sup> (653 cc)		39.8 in <sup>3</sup> (653 cc)	
Comp. Ratio	8.0 : 1		8.0 : 1	
Oil Capacity	2.0 quart (1.8 l)		2.0 quart (1.8 l)	
Valve Lash (Cold)	0.004 in (0.10 mm), Intake & Exhaust		0.004 in (0.10 mm), Intake & Exhaust	
Spark Plug	18-25 lbs-ft (23-32 N-m)		18-25 lbs-ft (23-32 N-m)	
Ignition Timing	20° BTDC, non-adjustable magneto		20° BTDC, non-adjustable magneto	
Magneto Air Gap	0.012 in (0.3 mm)		0.012 in (0.3 mm)	
Spark Plug Gap	0.025 in (6-7 mm)		0.025 in (6-7 mm)	
<b>DC SYSTEM:</b>				
Battery Voltage	12 volts		12 volts	
Min. Battery CCA	450 @ 0° F (-18° C)		450 @ 0° F (-18° C)	
<b>INSTALLATION:</b>				
Exhaust O. D.	1-1/4 in		1-1/4 in	
Max. Exhaust Back Pressure	-	-	-	-
Fuel Supply Connection	5/16 in. SAE J1231 Type 1	1/4 in. SAE J1231 Type 1	5/16 in. SAE J1231 Type 1	1/4 in. SAE J1231 Type 1

	GASOLINE MODELS			
	7.0 HGJAA	7.0 HGJAB	5.5 HGJAA	5.5 HGJAB
Fuel Return Connection	1/4 in. SAE J1231 Type 1	-	1/4 in. SAE J1231 Type 1	-
Noise dB(A) <sup>2</sup>	65	67	64	66
Weight	290 lb (132 Kg)	290 lb (132 Kg)	279 lb (127 Kg)	279 lb (127 Kg)
Compartment (H x D x W) <sup>3</sup>	HGJAA/HGJAB: 17.2 in x 23.2 in x 34.6 in (438 mm x 589 mm x 879 mm)			
1. Sequential Multiport Fuel Injection 2. Measurements @ 10 ft (3 m) in a typical RV installation, under an 4 kW load. 3. With 1/2 in. clearances. See the Installation Manual for additional considerations when sizing the genset compartment.				

	LPG MODELS			
	6.5 HGJAA	6.5 HGJAB	5.5 HGJAA	5.5 HGJAB
<b>GENERATOR:</b> 2-Pole Revolving Field, 2-Bearing, Self-Excited, 1-Phase, Vertical Shaft, Capped Digital Voltage Regulation				
Power	6500 watts		5500 watts	
Frequency	60 Hertz		60 Hertz	
Voltage	120 volts		120 volts	
Current	54.2 amp		45.8 amp	
Speed	3600 rpm		3600 rpm	
<b>FUEL CONSUMPTION:</b>				
No load	2.2 lbs/h (1.0 kg/h)	2.2 lbs/h (1.0 kg/h)	1.8 lbs/h (0.8 kg/h)	1.8 lbs/h (0.8 kg/h)
Half load	3.9 lbs/h (1.8 kg/h)	3.9 lbs/h (1.8 kg/h)	3.3 lbs/h (1.5 kg/h)	3.3 lbs/h (1.5 kg/h)
Full load	5.3 lbs/h (2.4 kg/h)	5.3 lbs/h (2.4 kg/h)	4.6 lbs/h (2.1 kg/h)	4.6 lbs/h (2.1 kg/h)
<b>ENGINE:</b> Air-Cooled, 4-Cycle Spark-Ignited, OHV, 90° V Twin Cyl, Vertical Shaft				
Fueling Method	Air/Fuel Mixer		Air/Fuel Mixer	
Governor	Mechanical		Mechanical	
Speed	2880 rpm		2400 rpm	
Bore	3.15 in (80 mm)		3.15 in (80 mm)	
Stroke	2.56 in (65 mm)		2.56 in (65 mm)	
Displacement	39.8 in <sup>3</sup> (653 cc)		39.8 in <sup>3</sup> (653 cc)	
Comp. Ratio	8.0 : 1		8.0 : 1	
Oil Capacity	2.0 quart (1.8 l)		2.0 quart (1.8 l)	
Valve Lash (Cold)	0.004 in (0.10 mm), Intake & Exhaust		0.004 in (0.10 mm), Intake & Exhaust	
Spark Plug	18-25 lbs-ft (23-32 N-m)		18-25 lbs-ft (23-32 N-m)	
Ignition Timing	20° BTDC, non-adjustable magneto		20° BTDC, non-adjustable magneto	

	LPG MODELS			
	6.5 HGJAA	6.5 HGJAB	5.5 HGJAA	5.5 HGJAB
Magneto Air Gap	0.012 in (0.3 mm)		0.012 in (0.3 mm)	
Spark Plug Gap	0.025 in (6-7 mm)		0.025 in (6-7 mm)	
<b>DC SYSTEM:</b>				
Battery Voltage	12 volts		12 volts	
Min. Battery CCA	450 @ 0° F (-18° C)		450 @ 0° F (-18° C)	
<b>INSTALLATION:</b>				
Exhaust O. D.	1-1/4 in		1-1/4 in	
Max. Exhaust Back Pressure	-	-	-	-
LPG Vapor: Connection Pressure	3/8-18 NPTF 9-13 in (228-330 mm) WC		3/8-18 NPTF 9-13 in (228-330 mm) WC	
LPG Liquid: Connection Pressure	1/4-18 NPTF Tank Pressure		1/4-18 NPTF Tank Pressure	
Noise dB(A) <sup>1</sup>	65	67	64	67
Weight	290 lb (132 Kg)	290 lb (132 Kg)	279 lb (127 Kg)	279 lb (127 Kg)
Compartment (H x D x W) <sup>2</sup>	HGJAA/HGJAB: 17.2 in x 23.2 in x 34.6 in (438 mm x 589 mm x 879 mm)			
1. Measurements @ 10 ft (3 m) in a typical RV installation, under an 4 kW load. 2. With 1/2 in. clearances. See the Installation Manual for additional considerations when sizing the genset compartment.				

This page is intentionally blank.



# 7 Information for California Genset Users

This genset meets the requirements of California's Exhaust Emissions Standards as stated on the nameplate. [Figure 1 \(Section 2.2\)](#) illustrates where this information appears on the nameplate.

As a California user of this genset, please be aware that unauthorized modifications or replacement of fuel, exhaust, air intake, or speed control system components that affect engine emissions are prohibited. Unauthorized modification, removal or replacement of the genset label is prohibited.

You should carefully review Operator (Owner), Installation and other manuals and information you receive with your genset. If you are unsure that the installation, use, maintenance or service of your genset is authorized, you should seek assistance from an approved Onan dealer.

California genset users may use [Table 6](#) as an aid in locating information related to the California Air Resources Board requirements for emissions control.

**TABLE 6. EMISSIONS CONTROL INFORMATION**

Genset Warranty Information	The California emissions control warranty statement is located in the same packet of information as this manual when the genset is shipped from the factory.
Engine Valve Lash	See <i>Specifications (Chapter 6)</i> .
Engine Ignition Timing	See <i>Specifications (Chapter 6)</i> .
Engine Fuel Requirements	<b>Gasoline Models:</b> The engine is certified to operate on unleaded gasoline. See Fuel Recommendations ( <a href="#">Section 2.4.1</a> ). <b>LPG Models:</b> The engine is certified to operate on LPG. See Fuel Recommendations ( <a href="#">Section 2.4.1</a> ).
Engine Lubricating Oil Requirements	See ENGINE OIL RECOMMENDATIONS ( <a href="#">Section 2.4.1</a> ).
Engine Fuel Mixture Settings	<b>Gasoline Models—Fuel Injection:</b> The precision-manufactured fuel injection system is not adjustable. <b>All Other Models:</b> The precision-manufactured carburetor is not adjustable.
Engine Adjustments	<b>Gasoline Models—Fuel Injection:</b> Not applicable <b>Gasoline Models—Carburetor:</b> See <a href="#">Figure 8 (Section 3.12)</a> . <b>LPG Models:</b> Not applicable.
Engine Emission Control System	<b>Gasoline Models—Fuel Injection:</b> The engine emissions control system consists of Sequential Multiport Fuel Injection (SFI). <b>All Other Models:</b> The engine emissions control system consists of internal engine design.

This page is intentionally blank.



## 8 How to Obtain Service

---

When you need service, parts, or product literature (such as the Service Manual) for your genset, contact the nearest authorized distributor. Onan has factory-trained representatives to handle your needs for genset parts and service.

Call 1-800-888-ONAN to contact the nearest Cummins/Onan or Onan-only distributor in the United States or Canada. (This automated service utilizes touch-tone phones only). Select OPTION 1 (press 1) to be automatically connected to the distributor nearest to you.

If you are unable to contact a distributor using the automated service, consult the Yellow Pages. Typically, our distributors are listed under:

GENERATORS - ELECTRIC,  
ENGINES - GASOLINE OR DIESEL, or  
RECREATIONAL VEHICLES - EQUIPMENT,  
PARTS AND SERVICE.

If you are outside North America, call Onan Corporation at 1-763-574-5000 from 7:30 AM to 4:00 PM, Central Standard Time, Monday through Friday, or fax 1-763-528-7229.

Before calling for service, have the following information available:

1. *The complete genset model number and serial number. See Model Identification (Page 4).*
2. *The date of purchase.*
3. *The nature of the problem. See [Chapter 5 on page 27](#).*

If you have difficulty in arranging service or resolving a problem, please contact the Service Manager at the nearest Cummins/Onan distributor for assistance.



***WARNING: Improper service or replacement of parts can result in severe personal injury, death, and/or equipment damage. Service personnel must be trained and experienced in performing electrical and/or mechanical service.***

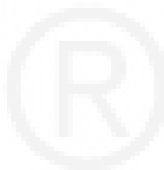



This page is intentionally blank.







This page is intentionally blank.





## Cummins **Onan**

Cummins Power Generation

1400 73rd Ave. NE

Minneapolis, MN 55432 USA

Phone 1 763 574 5000

Toll-free 1 800 888 6626

Fax 1 763 574 5298

Copyright © 2012 Cummins Power Generation, Inc. All rights reserved.

Cummins, the "C" logo, and "Performance you relay on." are trademarks of Cummins Inc.