

# PLAN 1535

---

American  
*Legend*  
HOMES®



Elevation A

BUILT FOR THE  
*WAY YOU LIVE*



# Structural Options

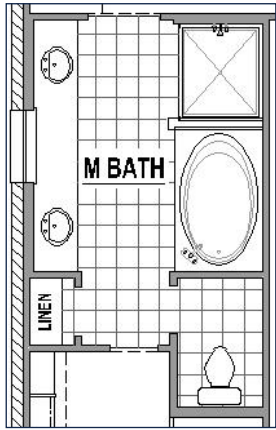

Drop in Tub at Main Bath

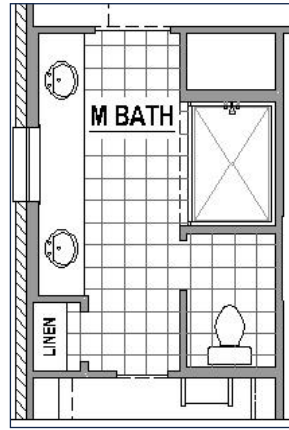

Alternate Main Bath Layout

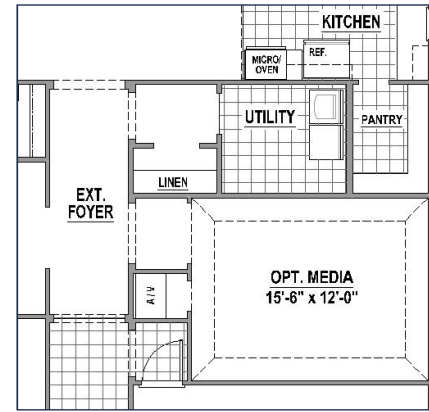

Media Room ILO Bedroom 4 & Storage Closet

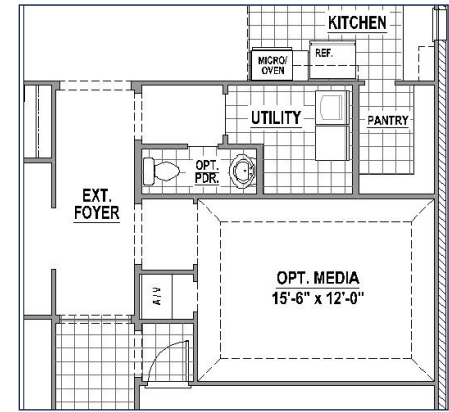

Media Room w/ Powder Bath ILO Bedroom 4 & Storage Closet

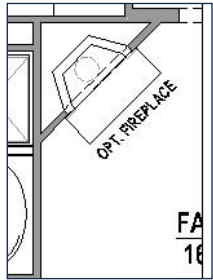

Fireplace at Family Room

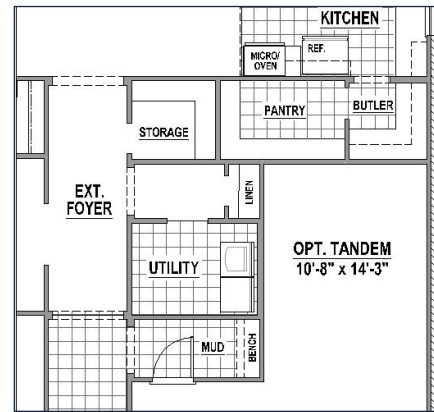

3rd Car Tandem Garage w/ Mud Bench

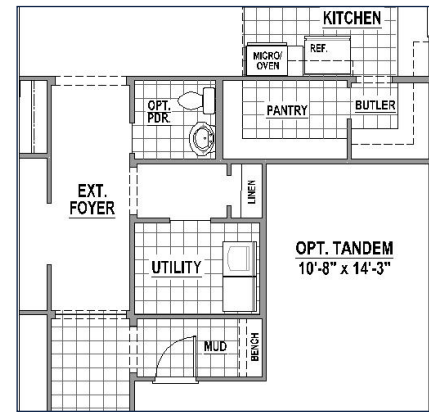

3rd Car Tandem Garage w/ Mud Bench & Powder Bath

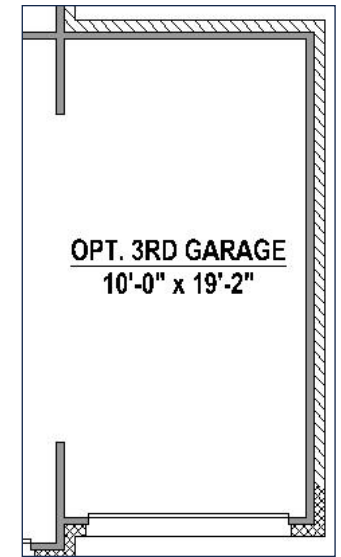

3rd Car Garage

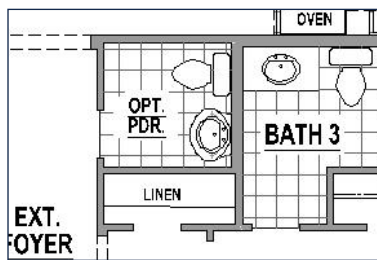

Powder Bath ILO Storage Closet

# PLAN 1535



**Elevation A with Stone**



**Elevation B**



**Elevation B with Stone**



**Elevation C**



**Elevation C with Stone**

American Legend Homes reserves the right to change prices, plans, specifications, square footage and availability without prior notice or obligation. Square footages are approximate and may vary upon elevations and/or options selected. Elevations depicted are an artist's rendering and are subject to change or modification without notice. Not responsible for typographical errors. Please see a Sales Associate for more information. American Legend Homes and the ALH logo are registered trademarks of American Legend Homes, LLC. © 2026 American Legend Homes. All rights reserved. Plan 1535.ABC\_05/11/26

