

Name

Research: Forces of Flight

Label the three axis of flight

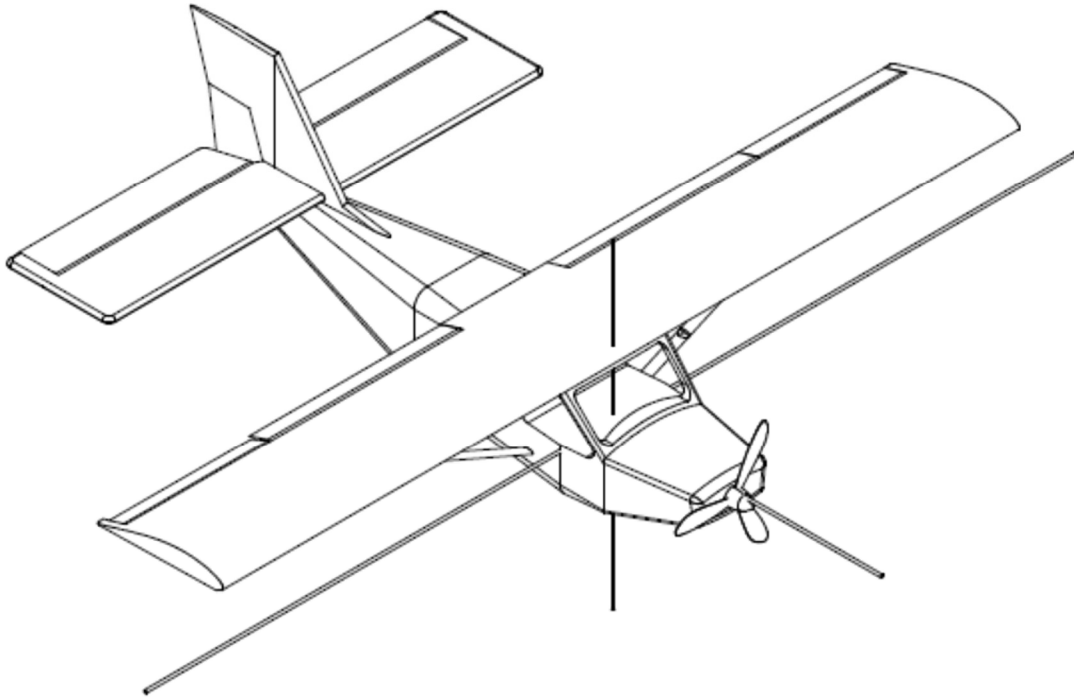

Label the four forces of flight

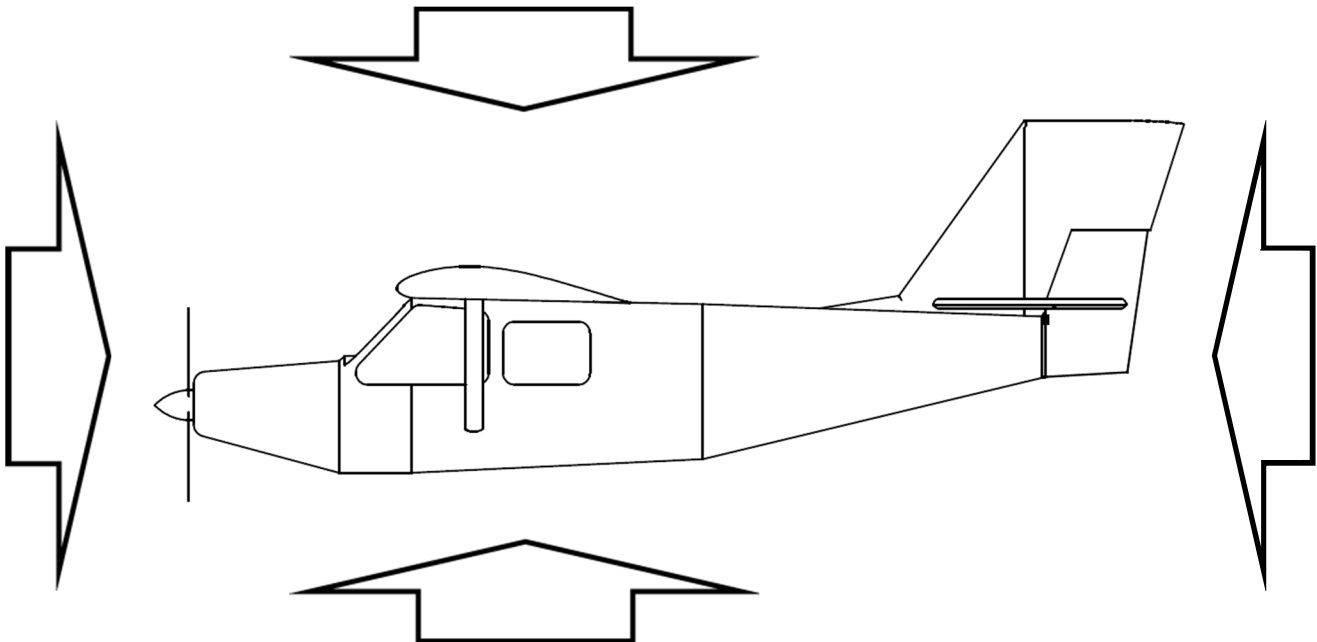

Name

Experiment: Relationship Between Thrust and Lift

Hypothesis- What we think is going to happen

I think that planes with bigger wings will fly a **shorter/longer** distance (circle) than planes with smaller wings when thrown softly.

Because _____

Method – How we are going to do the experiment

Equipment – Materials we need to do the experiment

Quick Sketch of Bullet Paper Airplane	Quick Sketch of Dart Paper Airplane
Top View	Top View
Front View	Front View

Variables- Details that are important to our experiment

One Thing we are changing: How hard we are throwing the airplane

Things we are trying to keep the same:

Angle at which we release the plane

Hand Motion

Setup:

Throw each plane, once hard and once soft.

Measure the approximate distance of each throw to the nearest tenth of a meter

Data Collection – Shows what happened during the experiment in words or numbers.

Individual Data

Test Flight	1 st Thrower Distance in Meters (to the nearest tenth)	2 nd Thrower Distance in Meters (to the nearest tenth)
Bullet thrown softly		
Dart thrown softly		
Bullet thrown hard		
Dart thrown hard		

Analysis – What happened during the experiment?

My hypothesis was **proven/disproven** (circle) because _____

Name

Design: Best airplane for the best event

Challenge: Create an airplane that will perform well in one of the three class challenges.

1. Airplane that flies the furthest – longest distance as measured from the flight line to the airplane
2. Airplane that stays in the air the longest – the longest time an airplane stays in the air before hitting the floor
3. Airplane that lands closest to the center of a target – the airplane that is the smallest distance from the center of the target

Constraints –Rules or limits of designs:

- Each design must only use one sheet of paper
- Only enter one design into the competition

Plan

What competition do you want your plane to do the best in? (Circle one)

Furthest

Longest in Air

Most Accurate

How is each of the four forces of flight important to chosen competition?

Lift	
Gravity	
Drag	
Thrust	

What Airplane Attributes do you think are most important to your design (you may not be able to fit all of them into a design at the same time)?

Attribute	Options (Circle One)	Why you think it's important	How do you plan to implement the attribute
Wing Size	Big Wings Small Wings		
Weight	In the Front In the Middle In the Back		
Body Length	Long Body Short Body		

Create two prototypes that will best match the attributes you think are important.

Prototype 1	Prototype 2
Top View	Top View
Front View	Front View

Testing: Test both prototypes in the testing area. Choose one prototype to enter into the competition

Which prototype did you pick? _____

How did you pick which prototype you are going to use? _____

Analysis

Did your plane perform as you expected? Why/Why not?

What is one attribute you would change on your plane if you were going to enter the competition again? Why?
