

Intelligent cascading kit

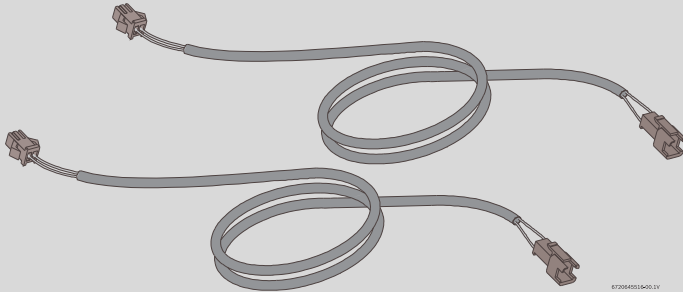

Kit components: Cascading cable (2X)

Approved for the Models: RTG 199HE/ME
RTG-K-160/199N/X1
RTG-K-160/199N/X2

Table of contents

1 Key to symbols and safety instructions	2
1.1 Key to symbols	2
1.2 Safety instructions	3
2 Cascading operation	3
2.1 Plumbing set up	3
2.2 Installation of Intelligent Cascading Kit.	6
2.3 Cascading settings	8
2.4 Primary/Secondary identification	10
2.5 Cascading operation	10

1 Key to symbols and safety instructions

1.1 Key to symbols

Warnings

In warnings, signal words at the beginning of a warning are used to indicate the type and seriousness of the ensuing risk if measures for minimising danger are not taken.

The following signal words are defined and can be used in this document:



DANGER:

DANGER indicates a hazardous situation which, if not avoided, will result in death or serious injury.



WARNING:

WARNING indicates a hazardous situation which, if not avoided, could result in death or serious injury.



CAUTION:

CAUTION indicates a hazardous situation which, if not avoided, could result in minor or moderate injury.

NOTICE:

NOTICE is used to address practices not related to personal injury.

Important information



The info symbol indicates important information where there is no risk to people or property.

Additional symbols

Symbol	Meaning
▶	a step in an action sequence
→	a reference to a related part in the document
•	a list entry
–	a list entry (second level)

Table 1

1.2 Safety instructions

⚠ WARNING:

Before installation,

- ▶ Read all instructions. Perform the steps in the indicated sequence.
- ▶ Failure to comply with these instructions can result in severe, possibly fatal, personal injury as well as damage to property and equipment.

⚠ DANGER:

Risk of electric shock!

- ▶ Ensure that only an authorized contractor performs electrical work.
- ▶ Before performing electrical work, disconnect the power and secure the unit against unintentional reconnection.
- ▶ Ensure the system has been disconnected from the power supply.

⚠ WARNING:

Risk of explosion!

For your safety

- ▶ Do not store or use gasoline or other flammable, combustible or corrosive vapors and liquids in the vicinity of this or any other appliance.

⚠ CAUTION:

Instruct the customer.

- ▶ Explain to the customer how the appliance works and how to operate it.

- ▶ Inform the customer that he/she must not carry out any alterations or repairs.

2 Cascading operation

Cascading allows up to twenty four appliances to be connected in parallel. One of the appliances will serve as the controlling primary appliance and will attempt to meet the hot water demand. If the hot water demand is beyond the capacity of the primary appliance, a signal is sent to one or more of the secondary appliances to ignite. A cascading kit must be installed for each secondary appliance included in the installation.

Example: A 7 unit cascade installation includes 1 primary appliance and 6 secondary appliances. 6 intelligent cascading kits must be for this installation.

2.1 Plumbing set up

The plumbing should be connected in the reverse return method with a minimum number of elbows to aid in balancing pressures between the appliances.

Locating the appliances as close as possible improves performance.

- Follow industry plumbing practices when installing multiple appliances.
- Minimum pipe diameter: ¾"
- Minimum water pressure: 50 psi
- Maximum distance between appliances: 36"
- Insulate pipes to prevent heat loss.

Cascading operation

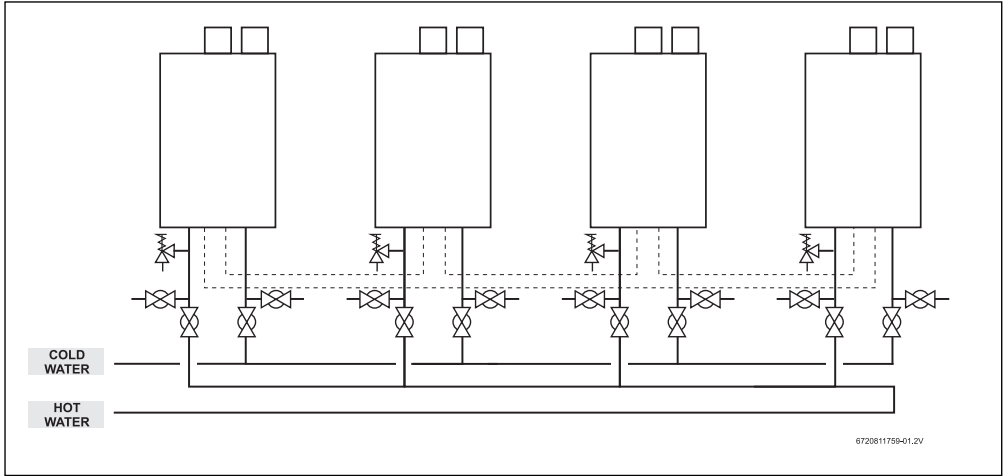

Fig. 1 Cascading setup for models RTG 199HE, RTG 199ME

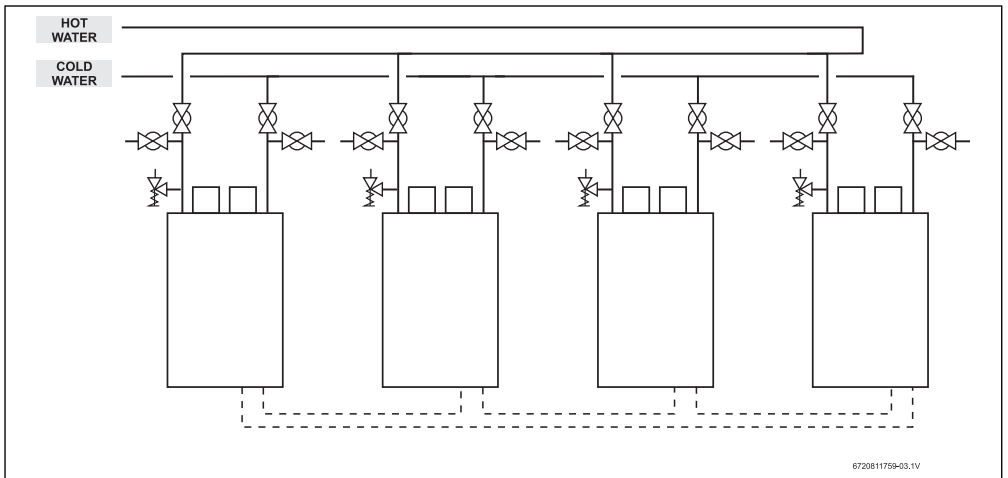

Fig. 2 Cascading setup for models RTG-K-199..1 and RTG-K-160..1

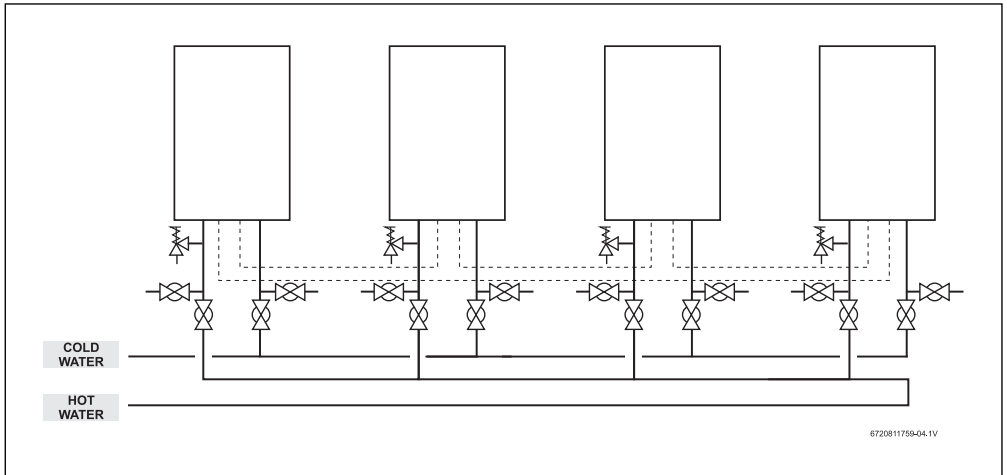

Fig. 3 Cascading setup for models RTG-K-199..2 and RTG-K-160..2

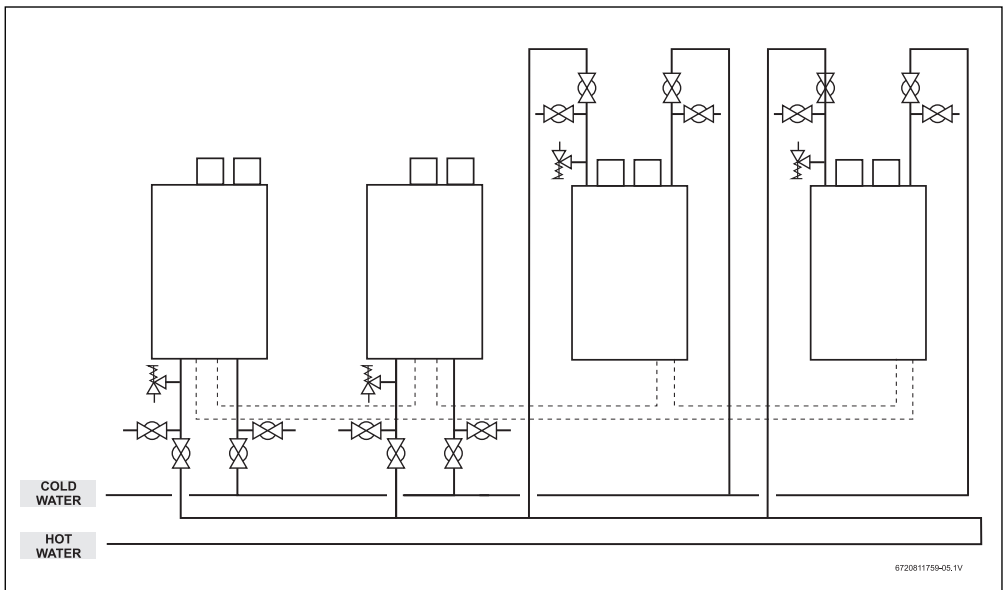

Fig. 4 Cascading setup with a combination of different model series

2.2 Installation of Intelligent Cascading Kit

Each appliance comes equipped with two connectors inside for the installation of the intelligent cascading kit. The connectors are labeled 'cascading input' and 'cascading output'.

2.2.1 Remove Front cover and ring sealing

- ▶ Loosen two Phillips head screws located on bottom of cover

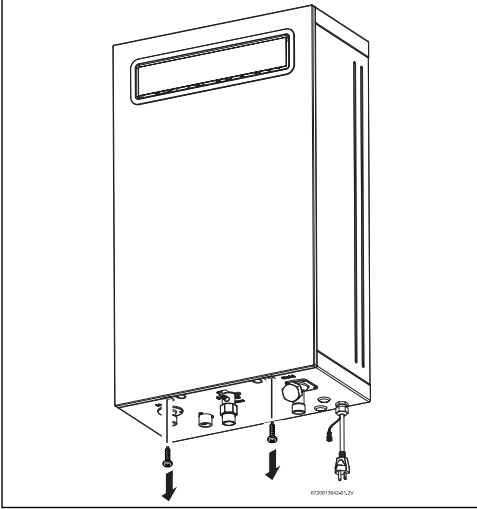

Fig. 5 Loosen two Philips head screws (for models RTG-K-199N/X2 and RTG-K-160N/X2)

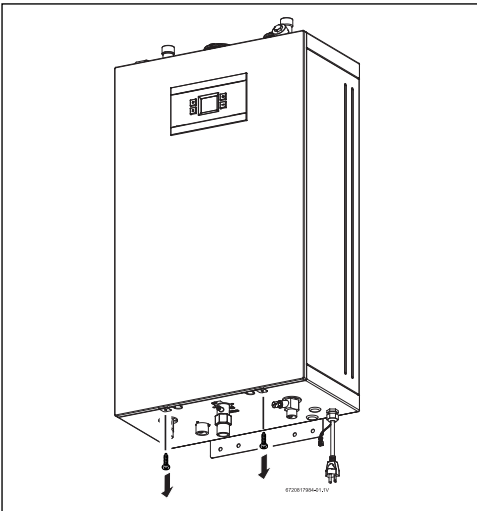

Fig. 6 Loosen two Philips head screws (for models RTG-K-199N/X1 and RTG-K-160N/X1)

- ▶ Lift the front cover to remove from the appliance [1].
- ▶ Disconnect the wire from the HMI (display) [2].

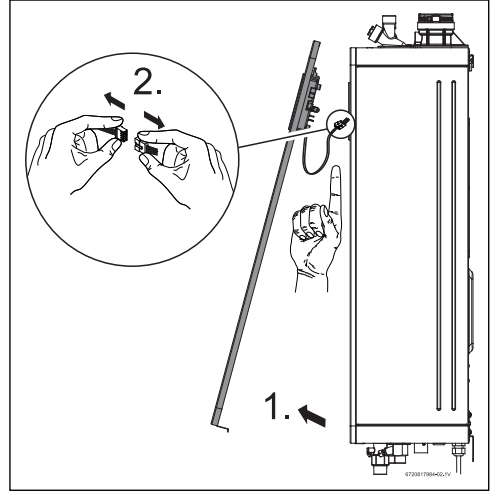

Fig. 7 Open front cover (for models RTG-K-199N/X1 and RTG-K-160N/X1)

- ▶ After removing front cover, remove ring sealings to access/connect the cascading cables between appliances.

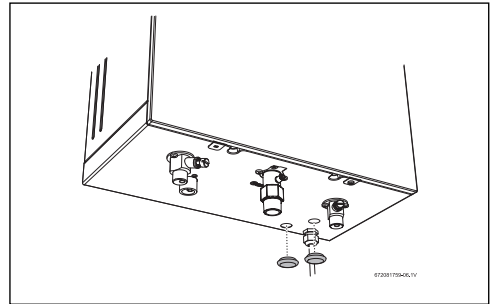

Fig. 8 Remove ring sealings (for models RTG-K-199N/X1, RTG-K-160N/X1, RTG-K-199N/X2 and RTG-K-160N/X2)

2.2.2 Connect the cascading cables between the appliances

To install the intelligent cascading cables:

- ▶ Connect all appliances together to form a ring.
 - Connect units in a row from the first to the last unit and then connect the last unit to the first one to close the ring (fig. 9 and fig. 10).
 - If one cable is not long enough, connect two or more cables in a row.
 - Use the holes at the bottom of the appliance to guide the cables to/from the appliance interior.

- ▶ Proceed with the same steps in section 2.2.1, in reverse order to connect HMI and install front cover in the appliance.

Appliances are now ready for cascading activation and configuration.

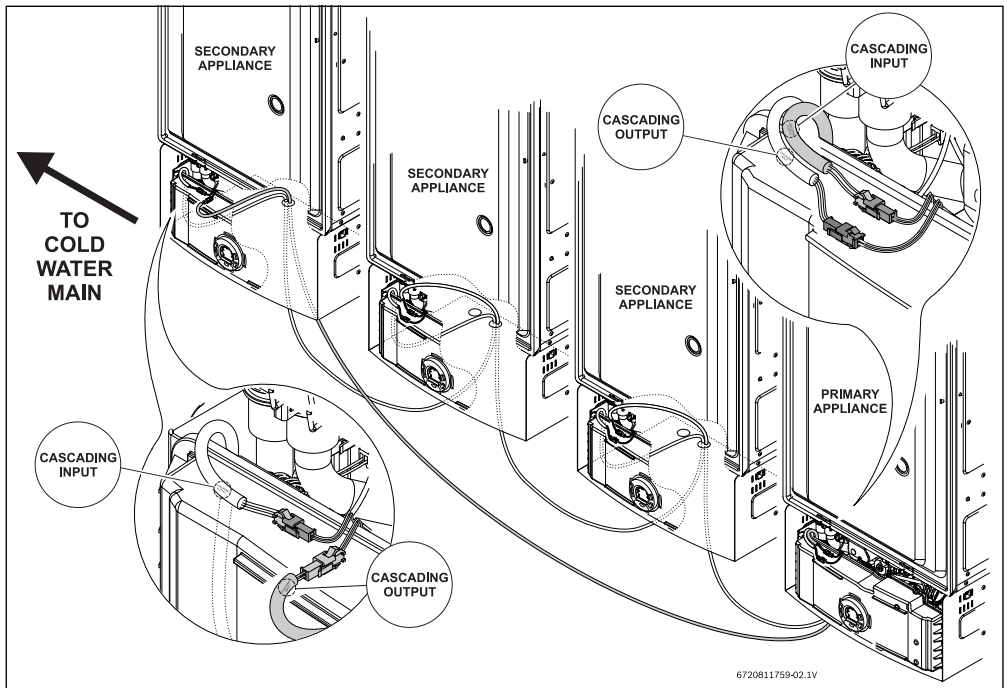

Fig. 9 Example of installation for: RTG 199HE, RTG 199ME

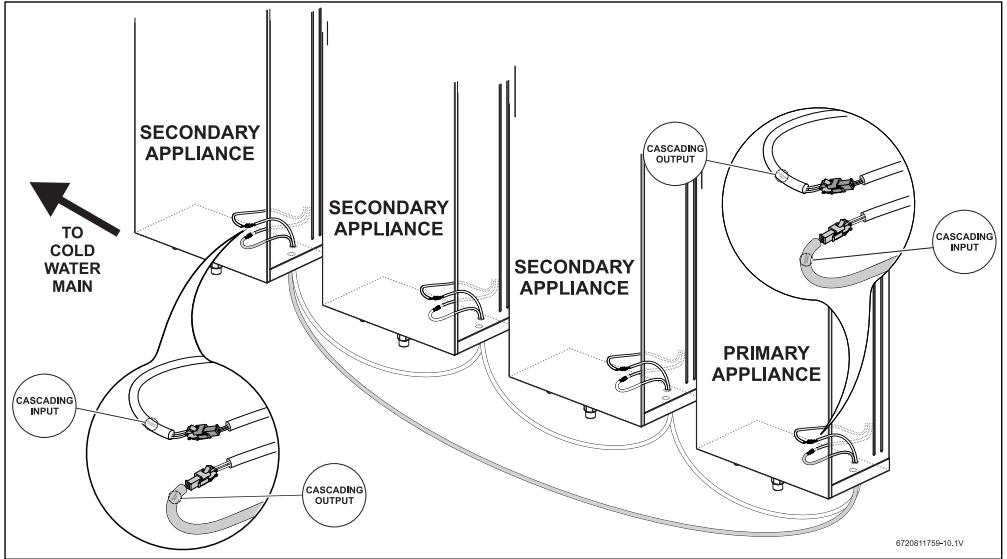

Fig. 10 Example of installation for: RTG-K-199N/X1, RTG-K-160N/X1, RTG-K-199N/X2 and RTG-K-160N/X2

2.3 Cascading settings



Perform this procedure on all appliances in the cascading setup.



This step can only be performed after installing the cascading cables according to the previous section.

2.3.1 For RTG 199HE, RTG 199ME appliances

- ▶ Push ON/OFF switch to the OFF position.
- 1. Press and hold the program button **P** and then press the ON/OFF button to the ON position. As soon as '188' flashes on the display, release the **P** button. The display should now read P2.
- 2. Press the **+** button until P5 appears.
- 3. Press Program button **P**. The display should now read NO (normal mode).
- 4. Press **+** button until CC (cascading mode) appears.
- 5. Press and hold Program button **P** until CC blinks on the display.
- 6. To enter in the main menu, press **P** button.

After the "CC" is selected, two new menus will become available in the main menu, PH and PC.

To access PH and PC menu,

- ▶ Press the **+** button until PH or PC appears.

PC - Primary and Secondary selection

- CN - Primary
 - Appliance defined as Primary. Only one appliance in the cascading system can be defined as Primary.
- CS - Secondary (default)
 - Appliance defined as secondary. All other appliances in the cascading systems must be secondary.

PH - Cascading mode selection

- IC - Intelligent Cascading (default)
 - The primary will rotate after 100h/work.
- SC - Simple Cascading
 - There will not be any primary rotation when this appliance is selected as primary.



Simple cascading option is not compatible with newer models (RTG-K-199/160).



Selection is done pressing the **P** button until the display starts flashing.

The appliance is now programmed to operate in the cascading mode.

2.3.2 For RTG-K-199N/X1, RTG-K-160N/X1, RTG-K-199N/X2 and RTG-K-160N/X2

- ▶ Press simultaneously **+** and **-** buttons, and **P** for 3 seconds.
Display shows **P4 (Information)**.

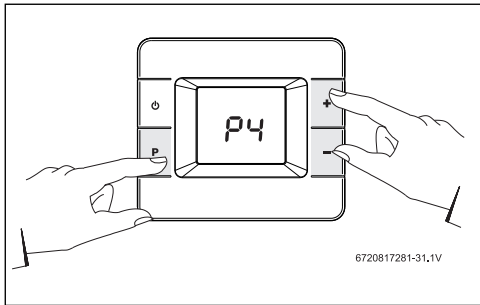

Fig. 11 P4 Information

- ▶ Press buttons **+** or **-** to scroll through the available menus.
- ▶ Select the option Cascading mode “PC”.

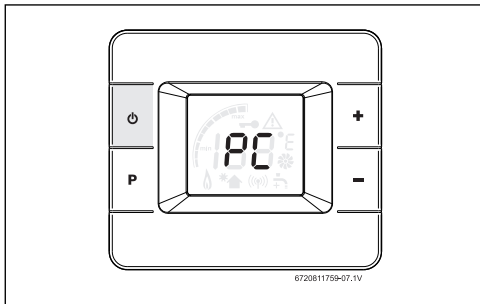

Fig. 12 Cascading

- ▶ Press the P button to enter PC (Cascading).

- ▶ Press buttons **+** or **-** to scroll through the options.
 - **MA (Primary)** - Appliance defined as Primary. Only one appliance in the cascading system can be defined as Primary.
 - **SL (Secondary)** - Appliance define as Secondary. All other appliances in the cascading systems must be secondary.
 - **OF (Off)** - Cascading is deactivated. If the cascading state is off in any appliance in the system, the cascading will not work independently of the cascading cables are connected.

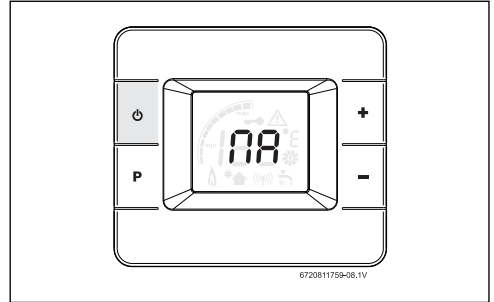

Fig. 13 Primary

How to select an option,

- ▶ Press buttons **+** or **-** to choose an option.
- ▶ Press the button P until selected option blinks.
Option is activated.
- ▶ Press the button P to exit PC menu.

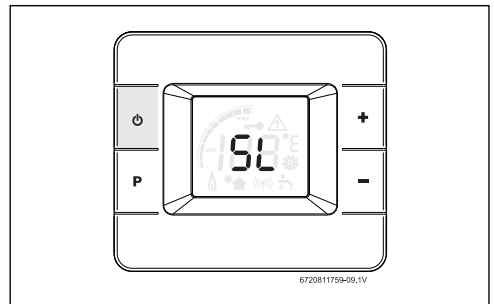

Fig. 14 Secondary

To return to main menu,

- ▶ Press buttons or until display shows **E**.
- ▶ Press button to exit.
Display shows temperature setpoint.

After configuring cascading in the primary and all secondary, appliances are ready to use.

2.4 Primary/Secondary identification

The primary appliance is identified by the following symbol;

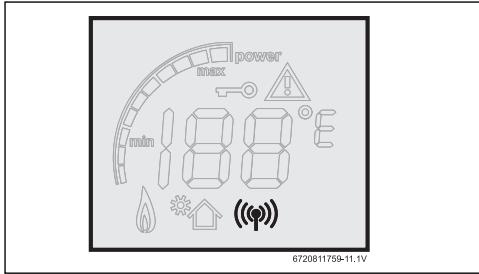

Fig. 15 Primary symbol in RTG 199HE/ME, RTG-K-199/166 cascading mode

2.5 Cascading operation

2.5.1 Secondary activation/deactivation

RTG 199HE, RTG 199ME models

The primary appliance serves as the controlling primary appliance and the remaining appliances (secondary) are inactive by default. If the hot water demand in the primary appliance reaches 85% (or above) of its capacity, a signal is sent to the first secondary appliance to ignite. If the same happens with the secondary appliance, then the next secondary in the cascading ring is activated, and so on.

When the hot water demand in any appliance reaches 30% (or below) of its capacity, it will send a signal to the next appliance in the cascading ring to deactivate.

RTG-K-199N/X1, RTG-K-160N/X1, RTG-K-199N/X2 and RTG-K-160N/X2 models

The primary appliance serves as the controlling primary appliance and the remaining appliances (secondary) are inactive by default. If the hot water demand in the primary appliance reaches 80% (or above) of its capacity, a signal is sent to the first secondary appliance to ignite. If the same happens with the secondary appliance, then the next secondary in the cascading ring is activated, and so on. An active secondary will then act as a primary to the next secondary.

When the hot water demand in any appliance reaches 20% (or below) of its capacity, it will send a signal to the next appliance in the cascading ring to deactivate.

2.5.2 Primary rotation

Primary rotation will happen when water flow is OFF and 100 burning hours are reached on the primary appliance. The primary appliance will transfer the primary attribute to the next appliance in the cascading ring.

2.5.3 Error handling

When one appliance in the cascading system is locked, due to an error code, all actions are sent to the next appliance. If the appliance is a Primary, it will request to the next appliance to be the primary.



If an appliance in cascading is powered off or its electronics are damaged or disconnected, or the cables are not properly connected, it will not send the necessary messages for correct cascading operation. If the damaged appliance is the primary, cascading will not work.

A damaged appliance must be turned OFF and the cascading cables must be disconnected from it. Bypass the damaged appliance by turning it OFF and disconnecting it from the cascading ring. Connect both ends of the cascading kit of the damaged appliance to ensure communication continuity on the cascading ring.

Additionally, if the damaged appliance is the Primary, another appliance has to be defined as Primary, see section 2.3.

2.5.4 Temperature set point change

If the set point temperature is changed in one appliance, then the set point will be updated in all appliances in the cascading system. Appliance specific set point range limitations continue to apply in cascading mode. To avoid set point temperature discrepancies across appliances in the cascading loop, ensure all appliances have the same set point range settings.

2.5.5 Remote control usage

Only one remote control is needed to change temperature setpoint in the system. It can be installed in any appliance, independently of being a primary or a secondary. However, the error codes present in any appliance in the system (except the one connected to the remote control) will not be visible in the remote.

2.5.6 Recirculation system

Appliance controlled recirculation cannot be activated simultaneously with cascading. If cascading mode is activated and you activate recirculation, the cascading mode will turn off and vice-versa.



6720811759



BRADFORD WHITE®
W A T E R H E A T E R S

Ambler, PA

For U.S. and Canada field service,
Contact your professional installer or
local Bradford White representative.

Sales/**800-523-2931**
Fax/**215-641-1670**
Parts Fax/**215-641-2180**

Technical Support/**800-334-3393**
Fax/**269-795-1089**

Warranty/**800-531-2111**
Fax/**269-795-1089**

International:
Telephone/**215-641-9400**
Telefax/**215-641-9750**



BRADFORD WHITE-CANADA™ INC.
A SUBSIDIARY OF BRADFORD WHITE CORPORATION

Mississauga, ON

Sales/**866-690-0961**
905-238-0100

Fax/**905-238-0105**
Technical Support/**800-334-3393**

Email
parts@bradfordwhite.com
techserv@bradfordwhite.com

www.bradfordwhite.com