

Residential Ultra High Efficiency Energy Saver Gas Water Heater



Photo is of
EFR-1-60T1206EN

The Ultra High Efficiency Water Heater Model Features:

- **95% Thermal Efficiency**—Ultra High Efficiency results in less fuel consumption and greater hot water recovery.
- **ICON HD™**—Intelligent proven design combines temperature control, diagnostic codes, and system ignition functions into a single control board with a digital LCD display
- **Low NOx Premix Power Burner**—Maintains extremely low NOx emissions while providing a high level of performance and reliability.
- **Self Compensating Negative Pressure Combustion System**—Automatically increases or decreases fuel flow when a change in combustion air is detected. This results in optimum combustion and efficiency levels as well as compensating for thinner air when installed at higher altitudes.
- **Operation Mode**—Two different digitally displayed operation modes have the capability of adjusting the temperature setting up to 180°F (82°C), and adjusting the degree setting (°F to °C, or °C to °F).
- **Intelligent Diagnostics**—An easy to use LCD display prompts the installer during start-up and provides 10 different diagnostic codes to assist in troubleshooting.
- **Venting Flexibility**—Can vent vertically or horizontally with either 2", 3" or 4" PVC, CPVC or ABS vent pipe and is approved to utilize outside air for combustion (Power Direct Vent), or inside air for combustion (Power Vent). Unbalanced venting can also be utilized, which means the air intake pipe does not have to be vented on the same external building surface as the exhaust vent (see reverse side for maximum vent lengths).
- **Supplemental Heating Capability**—Two 1" NPT side connections can easily be connected to space heating, geothermal heating or solar heating applications.
- **Factory Installed Hydrojet® Sediment Reduction System**—Cold water inlet sediment reducing device helps prevent sediment build up in the tank.
- **Vitraglas® Lining**—Bradford White tanks are lined with an exclusively engineered enamel formula that provides superior tank protection from the highly corrosive effects of hot water. This formula (Vitraglas®) is fused to the steel surface by firing at a temperature of over 1600°F (871°C).
- **Direct Spark Ignition**—Main burner is lit directly by a high voltage, low current spark from the spark rod to the burner surface for reliable, trouble-free ignitions. This results in savings of gas consumption during stand-by periods.
- **Non-CFC Insulation**—Surrounds the tank surface reducing the amount of heat loss. This results in less energy consumption, improved operational efficiencies and jacket rigidity.
- **Water Connections**—1" NPT factory installed dielectric fittings extend water heater life and eases installation.
- **Optional Concentric Vent Kit Termination**—2" or 3" termination fittings provide for only one exit opening through a wall or roof. (Subtract 10ft. for intake pipe and 10ft. for exhaust pipe when calculating total vent length).
- **Thermostatic Mixing Device**—Included.
- **Four Protective Magnesium Anode Rods**.
- **T&P Relief Valve**—Installed.
- **Low Restriction Brass Drain Valve**—Durable tamper proof design.

AUDI
ATRI



6-Year Limited Tank Warranties / 6-Year Limited Warranty on Component Parts.

For more information on warranty, please visit www.bradfordwhite.com

For products installed in USA, Canada and Puerto Rico. Some states do not allow limitations on warranties. See complete copy of the warranty included with the heater.

MANUFACTURED UNDER ONE OR MORE OF THE FOLLOWING U.S. PATENTS: 5,954,492; 5,761,379; 5,943,984; 5,081,696; 5,988,117; 6,142,216; 5,199,385; 5,574,822; 5,372,185; 5,485,879; 5,277,171; (B1)5,341,770; 5,660,165; 5,596,952; 5,682,666; 4,904,428; 5,023,031; 5,000,893; 4,669,448; 4,829,983; 4,808,356; 5,115,767; 5,092,519; 5,052,346; 4,416,222; 4,628,184; 4,861,968; 4,672,919; Re. 34,534; 7,270,087 B2. OTHER U.S. AND FOREIGN PATENT APPLICATIONS PENDING. CURRENT CANADIAN PATENTS: 1,272,914; 1,280,043; 1,289,832; 2,045,862; 2,112,515; 2,108,186; 2,107,012; 2,092,105; 2,409,271. Defender Safety System®, Vitraglas® and Hydrojet® are registered trademarks of Bradford White® Corporation.

Residential Ultra High Efficiency Gas Water Heater

eF Series® Energy Saver Models

Meet or exceed ASHRAE 90.1b (current standard) C.E.C. Listed

NATURAL GAS AND LIQUID PROPANE GAS

Model Number	Capacity		Thermal Efficiency	Recovery at 90°F Rise*		A Floor to Heater Top	B Jacket Dia.	C Vent Size	D Floor to T&P Conn.	E Floor to Gas Conn.	F Floor to Air Intake Conn. in.	G Floor to Exhaust Vent Conn. in.	H Floor to Cold Water Inlet in.	J Floor to Hot Water Outlet in.	Approx. Shipping Weight				
	U.S. Imp. Gal.	Imp. Gal.		Nat. BTU/Hr. Input	LP BTU/Hr. Input											Nat. U.S. Imp. GPH	LP U.S. Imp. GPH	lbs.	
EFR-1-60T1206EN	60	50	95%	120,000	120,000	154	128	154	128	57	28 1/4	3	40	53 1/2	52 1/2	5	13	42 1/2	570

Model Number	Capacity		Thermal Efficiency	Recovery at 50°C Rise*		A Floor to Heater Top	B Jacket Dia.	C Vent Size	D Floor to T&P Conn.	E Floor to Gas Conn.	F Floor to Air Intake Conn. mm.	G Floor to Exhaust Vent Conn. mm.	H Floor to Cold Water Inlet mm.	J Floor to Hot Water Outlet mm.	Approx. Shipping Weight		
	Liters	Liters		Nat. kW Input	LP kW Input											Nat. Liters/Hour	LP Liters/Hour
EFR-1-60T1206EN	227	227	95%	35.2	35.2	581	581	1448	718	76	1016	1359	1334	127	330	1080	259

For Propane (LP) models change suffix "EN" to "SX".

*Based on manufacturers rated recovery efficiency.

115V A.C. Required. Amp Draw Range = 1.0 - 1.8 amps.

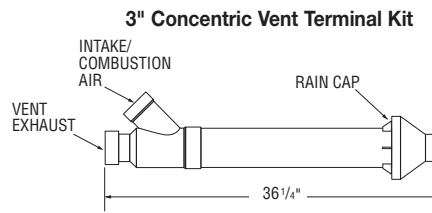
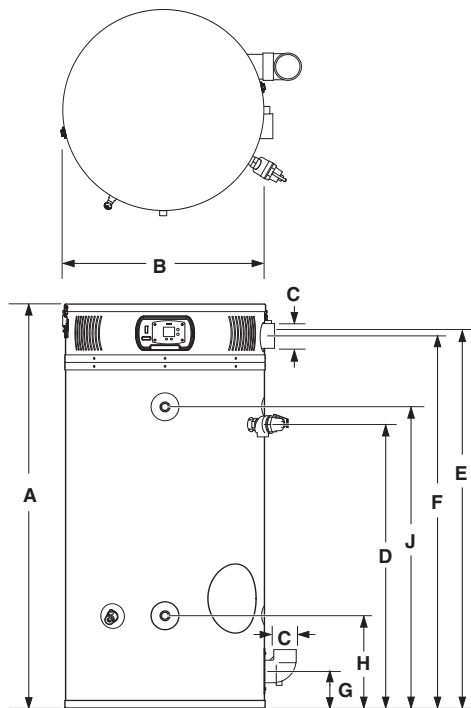

P/N 239-44069-01

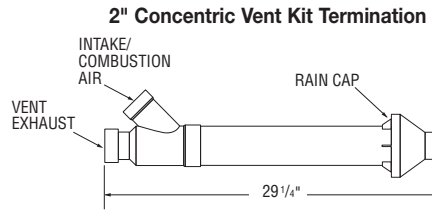

P/N 239-44069-02

2" Vent Pipe	Power Direct Vent	Power Vent
Max. Intake Length	30 ft.	N/A
Max. Exhaust Length	30 ft.	60 ft.
Min. Vent Length	7 ft.	7 ft.
Number of 90° Elbows	1: 25 ft. 2: 20 ft. 3: 15 ft.	55 ft. 50 ft. 45 ft.

3" Vent Pipe	Power Direct Vent	Power Vent
Max. Intake Length	60 ft.	N/A
Max. Exhaust Length	60 ft.	120 ft.
Min. Vent Length	7 ft.	7 ft.
Number of 90° Elbows	1: 55 ft. 2: 50 ft. 3: 45 ft.	115 ft. 110 ft. 105 ft.

4" Vent Pipe	Power Direct Vent	Power Vent
Max. Intake Length	85 ft.	N/A
Max. Exhaust Length	85 ft.	170 ft.
Min. Vent Length	7 ft.	7 ft.
Number of 90° Elbows	1: 80 ft. 2: 75 ft. 3: 70 ft.	165 ft. 160 ft. 155 ft.

Air intake cannot exceed exhaust by more than 30 ft. in any venting situation. Subtract 5 ft. for each additional 90° elbow.

Meets NAECA Requirements

General

All gas water heaters are certified at 300 PSI test pressure (2068 kPa) and 150 PSI working pressure (1034 kPa). All water connections are 1" NPT (25mm). All gas connections are 3/4" (19mm).

All models design certified by CSA International (formerly AGA/CGA), to meet ANSI standard Z-21.10.3 and peak performance rated.

Dimensions and specifications subject to change without notice in accordance with our policy of continuous product improvement.

Suitable for Water (Potable) Heating and Space Heating.

Toxic chemicals, such as those used for boiler treatment, shall NEVER be introduced into this system. This unit may NEVER be connected to any existing heating system or component(s) previously used with a non-potable water heating appliance.



For U.S. and Canada field service, contact your professional installer or local Bradford White sales representative.

Sales 800-523-2931 • Fax 215-641-1670 / Technical Support 800-334-3393 • Fax 269-795-1089 • Warranty 800-531-2111 • Fax 269-795-1089

International: Telephone 215-641-9400 • Telefax 215-641-9750 / www.bradfordwhite.com

BRADFORD WHITE-CANADA INC. Sales / Technical Support 866-690-0961 / 905-238-0100 • Fax 905-238-0105 / www.bradfordwhite.com

Built to be the Best™

©2013, Bradford White Corporation. All rights reserved.