

# Residential Ultra Low NOx Extra Recovery Energy Saver Gas Water Heater



Photo is of  
U2-XR-504T6FRN

### Identical Dimensions

Same diameter, height and connections as standard units for ease of installation.

### FEATURING:



### The FVIR Extra Recovery Eco-Defender Safety System<sup>®</sup> Models Feature:

- **Bradford White ICON System<sup>™</sup>**—Intelligent gas control with proven millivolt powered technology and built-in piezo igniter. A standard, off the shelf thermopile converts heat energy from the pilot flame into electrical energy to operate the gas valve and microprocessor. No need for external electricity.
  - **Enhanced Performance**—Proprietary algorithms provide enhanced First Hour Delivery ratings and tighter temperature differentials.
  - **Advanced Temperature Control System**—Microprocessor constantly monitors and controls burner operation to maintain consistent and accurate water temperature levels.
  - **Intelligent Diagnostics**—An exclusive green LED light prompts the installer during start-up and provides ten different diagnostic codes to assist in troubleshooting.
  - **Pilot On Indication**—Flashing green LED provides positive indication that pilot is on.
  - **Separate Immersed Thermowell**—High strength advanced polymer composite thermowell provides isolation between electric temperature sensor and surrounding water. No need to drain the tank when removing gas valve.
- **Defender Combustion Chamber**—Incorporates the Advanced ScreenLok<sup>®</sup> Technology Flame Arrestor and large split-door design to prevent ignition of flammable vapors outside the water heater (excluding 75 gallon model).
- **Ultra Low NOx Burner with Primary and Secondary Air Distribution Devices**—Ensures proper air to gas ratio for reduction of NOx generated by the combustion process.
- **Digital Thermal Sensor and Resettable Thermal Switch**—Coordinates with self diagnostic control to prevent water heater operation as needed (75 gallon has no thermal switch).
- **Maintenance Free**—No regular cleaning of air inlet openings or flame arrestor is required under normal conditions.
- **Sight Window**—Offers a view into the combustion chamber to observe the operation of the pilot and burner.
- **Factory Installed Hydrojet<sup>®</sup> Total Performance System**—Cold water inlet sediment reducing device helps prevent sediment build up in tank. Increases first hour delivery of hot water while minimizing temperature build up in tank.
- **Vitraglas<sup>®</sup> Lining**—Bradford White tanks are lined with an exclusively engineered enamel formula that provides superior tank protection from the highly corrosive effects of hot water. This formula (Vitraglas<sup>®</sup>) is fused to the steel surface by firing at a temperature of over 1600°F (871°C).
- **Side Connections**—3/4" NPT tapings allow an easy connection for space heating applications.
- **2" Non-CFC Foam Insulation**—Covers the sides and top of tank, reducing the amount of heat loss. This results in less energy consumption, improved operation efficiencies and jacket rigidity.
- **Pedestal Base**—Rugged and durable base allows easy transport and positioning, while providing corrosion resistant contact with floor.
- **Water Connections**—3/4" NPT factory installed true dielectric fittings extend water heater life and eases installation (1" NPT water connections for the 75 gallon).
- **Factory Installed Heat Traps**—Design incorporates a flexible disk that reduces heat loss in piping and eliminates the potential for noise generation.
- **Protective Magnesium Anode Rod**—Provides added protection against corrosion for long trouble-free service.
- **3x4 "Snap Lock" Draft Diverter**—Allows either 3" or 4" vent connections with inputs of 40,000 BTU/Hr. or less. Over 40,000 BTU/Hr. has the 4" "Snap Lock" Draft Diverter.
- **T&P Relief Valve**—Included.
- **Low Restriction Brass Drain Valve**—Durable tamper proof design.
- **Design Certified by CSA International (formerly AGA and CGA).**
- **Complies with the latest ultra-low NOx requirement (10 ng/J NOx limit).**

### 6 or 10-Year Limited Tank Warranties / 6 or 10-Year Limited Warranty on Component Parts.

For more information on warranty, please visit [www.bradfordwhite.com](http://www.bradfordwhite.com)

For products installed in USA, Canada and Puerto Rico. Some states do not allow limitations on warranties. See complete copy of the warranty included with the heater.

# Residential Atmospheric Vent Gas Water Heater

## Ultra Low NOx Energy Saver Models

NATURAL GAS

Meet or exceed ASHRAE 90.1b (current standard) C.E.C. Listed  
Recovery efficiency ranging up to 79%

Model Number	Capacity		Nat. BTU/Hr. Input	Recovery at 90°F Rise*		A Floor to Flue Conn.	B Jacket Dia.	C Vent Size	D Floor to T&P Conn.	E Floor to Gas Conn.	F Floor to Space Heating Return in.	G Floor to Space Heating Outlet in.	H Floor to Water Conn.	K Depth	Approx. Shipping Weight
	U.S. Gal.	Imp. Gal.		Nat. U.S. GPH	Nat. Imp. GPH	in.	in.	in.	in.	in.	in.	in.	in.	in.	
U1-XR-403S6FRN	40	33	40,000	43	36	50	20	3x4	41	11 <sup>5</sup> / <sub>8</sub>	13 <sup>1</sup> / <sub>2</sub>	41	48 <sup>1</sup> / <sub>2</sub>	24 <sup>1</sup> / <sub>4</sub>	137
U2-XR-504T6FRN	48	40	55,000	57	47	59 <sup>1</sup> / <sub>4</sub>	22	4	50	11 <sup>5</sup> / <sub>8</sub>	13 <sup>1</sup> / <sub>2</sub>	50	57	26	174
U2-XR-65T6FRN	65	54	55,000	57	47	63	24	4	53 <sup>1</sup> / <sub>2</sub>	11 <sup>5</sup> / <sub>8</sub>	13 <sup>1</sup> / <sub>2</sub>	53 <sup>1</sup> / <sub>2</sub>	60 <sup>3</sup> / <sub>4</sub>	28	213
U2-XR-75S6RN	75	63	76,000	82	69	64 <sup>1</sup> / <sub>16</sub>	26	4	53 <sup>3</sup> / <sub>8</sub>	14 <sup>3</sup> / <sub>4</sub>	16 <sup>1</sup> / <sub>2</sub>	53 <sup>3</sup> / <sub>8</sub>	61 <sup>3</sup> / <sub>8</sub>	29 <sup>1</sup> / <sub>8</sub>	269

  

Model Number	Capacity		Nat. kW Input	Recovery at 50°C Rise*		A Floor to Flue Conn.	B Jacket Dia.	C Vent Size	D Floor to T&P Conn.	E Floor to Gas Conn.	F Floor to Space Heating Return mm.	G Floor to Space Heating Outlet mm.	H Floor to Water Conn.	K Depth	Approx. Shipping Weight
	Liters			Nat. Liters/Hour	mm.	mm.	mm.	mm.	mm.	mm.	mm.	mm.	mm.	mm.	
U1-XR-403S6FRN	151		11.7	163	1270	508	76x102	1041	330	343	1041	1232	615	62	
U2-XR-504T6FRN	182		16.1	215	1505	559	102	1270	330	343	1270	1448	660	74	
U2-XR-65T6FRN	246		16.1	215	1600	609	102	1359	309	342	1359	1543	711	93	
U2-XR-75S6RN	284		22.3	310	1627	660	102	1356	375	419	1356	1559	740	122	

Available in Natural Gas only.

For 10 year models, change suffix from "6" to "10".

\*Based on manufacturers rated recovery efficiency.

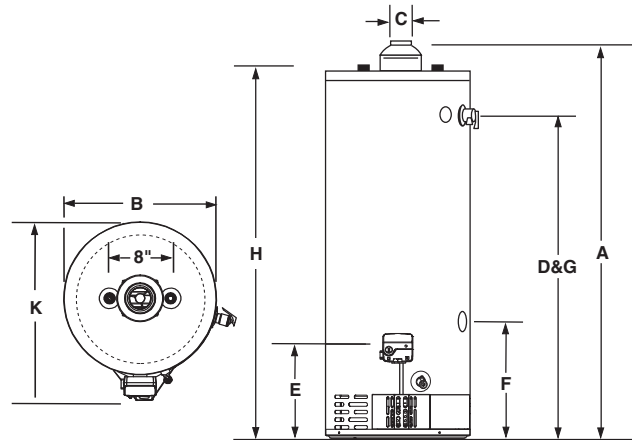

All models comply with the latest ultra-low NOx requirements of 10 ng/J or less.

### Meets NAECA Requirements

#### General

All gas water heaters are certified at 300 PSI test pressure (2068 kPa) and 150 PSI working pressure (1034 kPa). Water connections are 3/4" NPT (19mm) on 8" (203mm) centers (40, 50 and 65 gallon models). The 75 gallon model (284 liters) has 1" NPT (25mm) water connections on 11" (279mm) centers. All Gas Connections are 1/2" (13mm).

All models design certified by CSA International (formerly AGA/CGA), to meet ANSI standard Z-21.10.1 (Z-21.10.3 for 75-gallon) and peak performance rated.

*Dimensions and specifications subject to change without notice in accordance with our policy of continuous product improvement.*

#### Suitable for Water (Potable) Heating and Space Heating.

Toxic chemicals, such as those used for boiler treatment, shall NEVER be introduced into this system. This unit may NEVER be connected to any existing heating system or component(s) previously used with a non-potable water heating appliance.



For U.S. and Canada field service, contact your professional installer or local Bradford White sales representative.

Sales 800-523-2931 • Fax 215-641-1670 / Technical Support 800-334-3393 • Fax 269-795-1089 • Warranty 800-531-2111 • Fax 269-795-1089

International: Telephone 215-641-9400 • Telefax 215-641-9750 / [www.bradfordwhite.com](http://www.bradfordwhite.com)

**BRADFORD WHITE-CANADA** INC. Sales / Technical Support 866-690-0961 / 905-238-0100 • Fax 905-238-0105 / [www.bradfordwhite.com](http://www.bradfordwhite.com)

**Built to be the Best™**

©2013, Bradford White Corporation. All rights reserved.