

TTW2

Residential Through-The-Wall Energy Saver Gas Water Heater



M-2-TW-50T6BN

The TTW2 Models Feature:

- **Power Vented Heater**—Designed for installations where atmospheric units cannot be used. Exhaust gases are vented under positive pressure directly out of the building through the wall or the roof.
- **Powerful Blower Motor**—Our design has higher torque for greater resistance to outside winds and the power to eliminate problems with difficult venting situations. This significantly quieter motor runs cooler for a considerably longer operational life.
- **Spark-to-Pilot Ignition System**—Eliminates the constant burning pilot used on other water heaters. This device results in savings of pilot gas during standby periods (110 VAC required to heater).
- **PVC, ABS or CPVC Venting**—Horizontal and vertical venting up to 60 equivalent feet for 3" pipe, and up to 90 equivalent feet for 4" pipe. See reverse side for specifics.
- **Vitraglas® Lining**—Bradford White water heater tanks are protected from the corrosive effects of hot water by a ceramic porcelain-like coating. The exclusive high silica ceramic lining provides a tough interior surface for our water heater tank.
- **Steel Tank**—Heavy gauge steel automatically formed, rolled and welded to assure a continuous seam for glass lining.
- **Side connections**—Side tapings allow easy connection for space heating applications.
- **Protective magnesium rod**—Provides added protection against corrosion for long trouble-free service.
- **Factory installed Hydrojet® Total Performance System**—Cold inlet sediment reducing device. Helps prevent sediment build up in tank. Increases first hour delivery of hot water while minimizing temperature build up at top of tank.
- **Factory installed Heat Traps**—Design incorporates a flexible disk that reduces heat loss in piping and eliminates the potential for noise generation (M-2-TW-75T6BN does not have heat traps).
- **Water Connections**—3/4" NPT factory installed true dielectric fittings. Extends water heater life and eases installation (M-2-TW-75T6BN has factory installed dielectric waterway fittings).
- **2" Non-CFC Foam Insulation**—Covers the sides and top of tank to save energy by retarding loss of heat. Also increases jacket rigidity. (The M-2-TW-65 has 1" of foam insulation.)
- **Electronic Gas Control Valve**—The integrated, immersion gas control valve offers more precise temperature control for higher first hour delivery and also allows water temperature adjustment without removing the cover. The control is equipped with an LED display to aid in start-up and diagnostics.
- **Brass Drain Valve.**
- **T&P Relief Valve included**
- **Stainless Steel Flue baffle**—Designed to maximize the amount of heat absorbed in the lower portion of tank. Reduces air movement in the heater during standby periods to retard heat loss up the flue.
- **Design certified by CSA International (formerly AGA and CGA).**



6-Year Limited Warranty on Component Parts / 6 or 10-Year Limited Tank Warranties.

For more information on warranty, please visit www.bradfordwhite.com

For products installed in USA, Canada and Puerto Rico. Some states do not allow limitations on warranties. See complete copy of the warranty included with the heater.

TTW[®] 2 Through-The-Wall Gas Water Heater

Deluxe Energy Saver Models

NATURAL GAS AND LIQUID PROPANE GAS

Meet or exceed ASHRAE 90.1b (current standard) C.E.C. Listed
80% Recovery Efficiency

Model Number	Capacity		Recovery 90°F Rise*				A Floor to Vent Conn. in.	B Jacket Dia. in.	C Vent Size in.	D Floor to T&P Conn. in.	E Floor to Gas Conn. in.	F Floor to Space Heating Return in.	G Floor to Space Heating Outlet in.	H Floor to Heater Top in.	J Floor to Water Conn. in.	K Depth in.	Approx. Shipping Weight lbs.		
	U.S. Gal.	Imp. Gal.	Nat. BTU Input	LP BTU Input	Nat. Imp. Gas	Nat. Imp. GPH												LP Rec.	LP Imp. GPH
M-2-TW-50T6BN	48	40	65,000	60,000	70	58	65	265	66%	22	3	50%	12½	14½	51	57	58½	27	180
M-2-TW-65T6BN	65	54	65,000	63,000	70	58	68	265	70%	22	3	54%	12½	14½	54½	60%	61½	27½	186
M-2-TW-75T6BN	75	62	76,000	75,100	82	68	81	310	66%	26	3	49%	11½	14½	49%	56%	58%	30%	277

Model Number	Capacity		Recovery 50°C Rise*				A Floor to Vent Conn. mm.	B Jacket Dia. mm.	C Vent Size mm.	D Floor to T&P Conn. mm.	E Floor to Gas Conn. mm.	F Floor to Space Heating Return mm.	G Floor to Space Heating Outlet mm.	H Floor to Heater Top mm.	J Floor to Water Conn. mm.	K Depth mm.	Approx. Shipping Weight kg.
	Liters		Nat. kW Input	LP kW Input	Nat. Liters/Hour	LP Liters/Hour											
M-2-TW-50T6BN	182		19	17.6	54	246	1700	560	76	1290	320	368	1295	1448	1480	686	82
M-2-TW-65T6BN	246		19	18.5	57	257	1780	560	76	1380	320	368	1385	1543	1562	692	85
M-2-TW-75T6BN	284		22.3	22	67	307	1685	660	76	1260	292	368	1257	1445	1480	781	126

All propane heaters are equipped with a cast iron burner. To order a propane heater change suffix "BN" to "CX".
For 10 year models, change suffix from "6" to "10".

*Based on manufacturers rated recovery efficiency.

110 V.A.C. Required for Power Venting / 110 V.A.C. 60HZ 3.1 Amperes

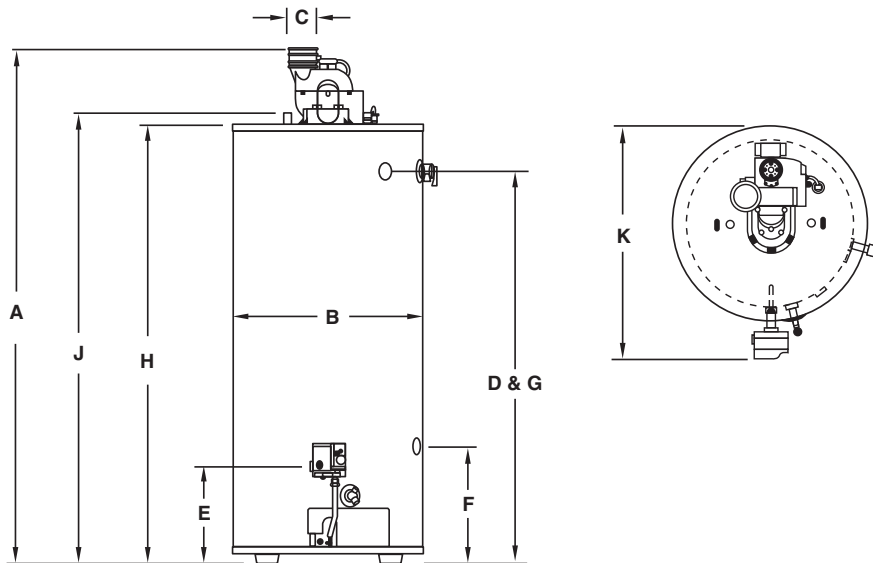

3" Vent Pipe	M-2-TW50	M-2-TW75
Max. Equivalent Length	60 ft.	†50 ft.
Min. Equivalent Length	7 ft.	7 ft.
Number of 90° Elbows	1 55 ft. 2 †50 ft. 3 45 ft.	45 ft. 40 ft. 35 ft.

4" Vent Pipe	M-2-TW50	M-2-TW75
Max. Equivalent Length	90 ft.	80 ft.
Min. Equivalent Length	15 ft.	15 ft.
Number of 90° Elbows	1 85 ft. 2 80 ft. 3 75 ft.	75 ft. 70 ft. 65 ft.

† For high altitude installations, consult the installation instructions.

All natural gas models meet SCAQMD Requirements. Meets NAECA Requirements.

General

All gas water heaters are certified at 300 PSI (2068 kPa) test pressure and 150 PSI (1034 kPa) working pressure.

All water connections are 3/4" NPT (19mm) on 11" (279mm) centers, all gas connections are 1/2" (13mm).

All models design certified by CSA International (formerly AGA/CGA), ANSI Z-21.10.1 and peak performance rated.

Dimensions and specifications subject to change without notice in accordance with our policy of continuous product improvement.

Suitable for Water (Potable) Heating and Space Heating

Toxic chemicals, such as those used for boiler treatment, shall NEVER be introduced into this system. This unit may NEVER be connected to any existing heating system or component(s) previously used with a non-potable water heating appliance.



Ambler, PA

For U.S. and Canada field service, contact your professional installer or local Bradford White sales representative.

Sales 800-523-2931 • Fax 215-641-1670 / Technical Support 800-334-3393 • Fax 269-795-1089 • Warranty 800-531-2111 • Fax 269-795-1089

International: Telephone 215-641-9400 • Telefax 215-641-9750 / Fax on Demand 888-538-7833 / www.bradfordwhite.com

BRADFORD WHITE - CANADA INC. Sales / Technical Support 866-690-0961 / 905-238-0100 • Fax 905-238-0105 / www.bradfordwhitecanada.com

Count On Bradford White
For *Everything* Hot Water™

©2006, Bradford White Corporation. All rights reserved.