

Residential TTW® High Performance Energy Saver Gas Water Heater



Photo is of
GX-1-TW-55S6BN

The Power Vent High Performance Model features:

- **Bradford White ICON System™**—Intelligent gas control with spark to pilot ignition system eliminates the constant burning pilot. This results in savings of pilot gas during stand by periods (120 V.A.C.).
 - **Enhanced Performance**—Proprietary algorithms provide enhanced First Hour Delivery ratings and tighter temperature differentials.
 - **Advanced Temperature Control System**—Microprocessor constantly monitors and controls burner operation to maintain consistent and accurate water temperature levels.
 - **Intelligent Diagnostics**—An exclusive green LED light prompts the installer during start-up and provides ten different diagnostic codes to assist in troubleshooting.
 - **Separate Immersed Thermowell**—High strength advanced polymer composite thermowell provides isolation between electric temperature sensor and surrounding water. No need to drain the tank when removing gas valve.
- **Compatible With Optional Accessory Packages**—Setback Control Package, Protection Package and Inlet Shut-Off Valve.
- **Power Vented Water Heater**—Designed for installations where atmospheric units cannot be used. Exhaust gases are vented under positive pressure directly out of the building through the roof or the wall.
- **Powerful Blower Motor**—Our significantly quiet design has greater resistance to outside winds and the power to vent in many difficult venting situations.
- **Horizontal and Vertical Venting**—With 3" or 4" PVC, ABS or CPVC (maximum equivalent vent lengths on reverse side).
- **High Input Combustion System**—Generates enough hot water in the first hour for whirlpool tubs, garden tubs or body sprays in addition to whole house duty.
- **High Recovery and First Hour Delivery**—When tested to the industry standard residential first hour delivery procedure, the GX-1-TW-55S will deliver 200 gallons.
- **Helical Fin Flue**—Specifically welded fins slow down the products of combustion, optimizing increased surface area efficiency and the amount of heat transferred to the water.
- **Factory Installed Hydrojet 2™ Total Performance System**—Cold water inlet sediment reducing device helps prevent sediment build up in tank. Increases first hour delivery of hot water while minimizing temperature build up in tank.
- **Vitraglas® Lining**—Bradford White tanks are lined with an exclusively engineered enamel formula that provides superior tank protection from the highly corrosive effects of hot water. This formula (Vitraglas®) is fused to the steel surface by firing at a temperature of over 1600°F (871°C).
- **1" Non-CFC Foam Insulation**—Covers the sides and top of tank, reducing the amount of heat loss. This results in less energy consumption, improved operation efficiencies and jacket rigidity
- **Pedestal Base.**
- **Water Connections**—3/4" NPT factory installed true dielectric fittings.
- **3/4" NPT Side Connections.**
- **Two Protective Magnesium Anode Rods.**
- **T&P Relief Valve**—Installed.
- **Low Restriction Brass Drain Valve**—Durable tamper proof design.
- **Thermostatic Mixing Valve (ASSE Approved)**—Included.

FEATURING:



**AUDI
ATRI**



6-Year Limited Tank Warranties / 6-Year Limited Warranty on Component Parts.

For more information on warranty, please visit www.bradfordwhite.com

For products installed in USA, Canada and Puerto Rico. Some states do not allow limitations on warranties. See complete copy of the warranty included with the heater.

Residential Power Vent Gas Water Heater

TTW® High Performance Energy Saver Model

NATURAL GAS AND LIQUID PROPANE MODELS

Meet or exceed ASHRAE 90.1b (current standard) C.E.C. Listed
82% Thermal Efficiency

Model Number	Capacity		Recovery at 90°F Rise*				A	B	C	D	E	F	G	H	J	K	Approx. Shipping Weight		
	U.S. Gal.	Imp. Gal.	Nat. BTU/Hr. Input	LP BTU/Hr. Input	Nat. U.S. GPH	Nat. Imp. GPH	U.S. GPH	Imp. GPH	Floor to Flue Conn. in.	Jacket Dia. in.	Vent Size in.	Floor to T&P Conn. in.	Floor to Gas Conn. in.	Floor to Space Heating Return in.	Floor to Space Heating Outlet in.	Floor to Heater Top in.		Floor to Water Conn.† in.	Depth in.
GX-1-TW-55S6BN	55	46	78,000	78,000	84	70	84	70	63 ³ / ₄	22	3	48	11 ¹ / ₂	13 ³ / ₈	48	54	58	27 ³ / ₈	215
Model Number	Capacity		Recovery at 50°C Rise*				A	B	C	D	E	F	G	H	J	K	Approx. Shipping Weight		
	Liters		Nat. kW Input	LP kW Input	Nat. Liters/Hour	LP Liters/Hour	mm.	mm.	mm.	mm.	mm.	mm.	mm.	mm.	mm.	mm.		mm.	kg.
GX-1-TW-55S6BN	208		22.9	22.9	317	317	1660	559	76	1219	279	330	1219	1372	1473	695	97		

Propane models feature a Titanium Stabilized Stainless Steel propane burner.

For propane (LP) models, change suffix "BN" to "SX".

*Based on manufacturers rated recovery efficiency.

†Dimension to top of installed mixing device.

110 V.A.C. Required for Power Venting / 110 V.A.C., 60HZ, 3.1 Amperes

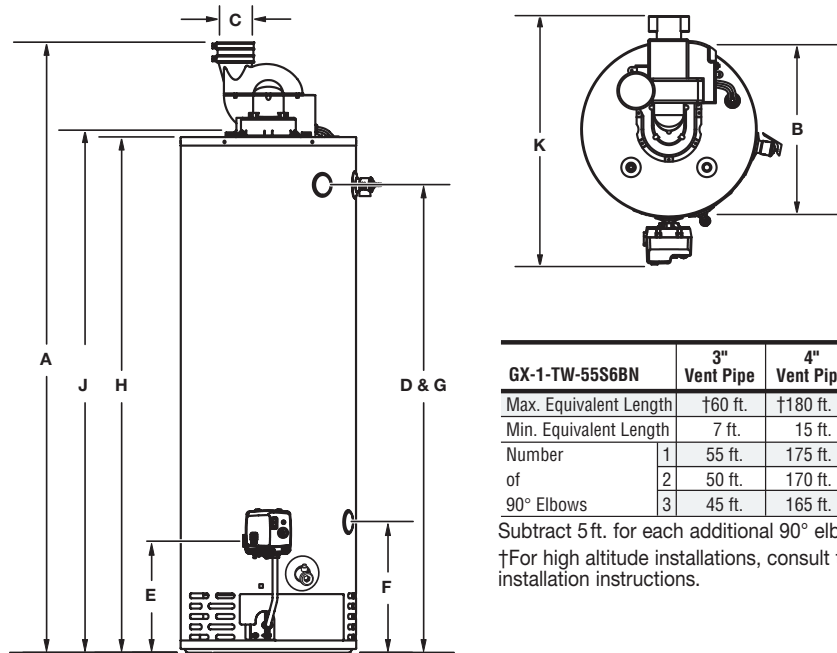

GX-1-TW-55S6BN	3" Vent Pipe	4" Vent Pipe
Max. Equivalent Length	†60 ft.	†180 ft.
Min. Equivalent Length	7 ft.	15 ft.
Number of 90° Elbows	1 2 3	55 ft. 175 ft. 170 ft. 165 ft.

Subtract 5 ft. for each additional 90° elbow.

†For high altitude installations, consult the installation instructions.

General

All gas water heaters are certified at 300 PSI test pressure (2068 kPa) and 150 PSI working pressure (1034 kPa). All water connections are 3/4" NPT (19mm) on 8" (203mm) centers. All gas connections are 1/2" (13mm).

All models design certified by CSA International (formerly AGA/CGA), ANSI standard Z-21.10.3 and peak performance rated.

Dimensions and specifications subject to change without notice in accordance with our policy of continuous product improvement.

Suitable for Water (Potable) Heating and Space Heating.

Toxic chemicals, such as those used for boiler treatment, shall NEVER be introduced into this system. This unit may NEVER be connected to any existing heating system or component(s) previously used with a non-potable water heating appliance.



For U.S. and Canada field service, contact your professional installer or local Bradford White sales representative.

Sales 800-523-2931 • Fax 215-641-1670 / Technical Support 800-334-3393 • Fax 269-795-1089 • Warranty 800-531-2111 • Fax 269-795-1089

International: Telephone 215-641-9400 • Telefax 215-641-9750 / www.bradfordwhite.com

BRADFORD WHITE-CANADA INC. Sales / Technical Support 866-690-0961 / 905-238-0100 • Fax 905-238-0105 / www.bradfordwhite.com

Built to be the Best™

©2014, Bradford White Corporation. All rights reserved.