

Light Duty Commercial Ultra Low NOx Direct Vent Gas Water Heater



Photo is of
ULG2DV50H453N

FEATURING:



The Direct Vent FVIR Eco-Defender Safety System[®] Models Feature:

- **Bradford White ICON System[™]**—Intelligent gas control with proven millivolt powered technology and built-in piezo igniter. A standard, off the shelf thermopile converts heat energy from the pilot flame into electrical energy to operate the gas valve and microprocessor. No need for external electricity.
 - **Enhanced Performance**—Proprietary algorithms provide enhanced First Hour Rating and tighter temperature differential.
 - **Advanced Temperature Control System**—Microprocessor constantly monitors and controls burner operation to maintain consistent and accurate water temperature levels.
 - **Intelligent Diagnostics**—An exclusive green LED light prompts the installer during start-up and provides ten different diagnostic codes to assist in troubleshooting.
 - **Pilot On Indication**—Flashing green LED provides positive indication that pilot is on.
 - **Separate Immersed Thermowell**—High-strength advanced polymer composite thermowell provides isolation between electric temperature sensor and surrounding water. No need to drain the tank when removing gas valve.
- **Ultra Low NOx Burner with Primary and Secondary Air Distribution Devices**—Ensures proper air to gas ratio for reduction of NOx generated by the combustion process.
- **Closed Combustion**—All air for combustion is taken directly from the outside. The co-axial vent pipe (pipe inside a pipe) draws combustion air in through the outer pipe and exhausts the products of combustion through the inner pipe. The co-axial vent pipe at the top of the unit can be rotated for venting flexibility.
- **Reinforced Seals**—Seals surround the closed combustion chamber and the FVIR inner door, preventing the ignition of Flammable Vapors outside of the water heater.
- **Maintenance-Free**—The vent piping and the closed combustion chamber with reinforced seals does not require regular cleaning under normal operating conditions.
- **Sight Window**—Offers a view into the combustion chamber to observe the operation of the pilot and burner.
- **Factory-Installed Hydrojet[®] Total Performance System**—Sediment reducing device that also increases first hour delivery of hot water while minimizing temperature build-up in tank.
- **Vitraglas[®] Lining**—An exclusively engineered enamel formula that provides superior tank protection from the highly corrosive effects of hot water. This formula (Vitraglas[®]) is fused to the steel surface by firing at a temperature of over 1600°F (871°C).
- **Cast Aluminum Air Intake Boot**—A cast molded air intake boot provides exceptional installation durability.
- **Telescoping Solid Vent Kits**—Multiple kits (see reverse side) allow up to 8ft. (2.4m) vertical and 8ft. (2.4m) horizontal vent lengths (horizontal termination only).
- **Flexible Vent Kit**—The maximum vent length (horizontal and vertical) can be flexed to 100" (2540mm) (horizontal termination only).
- **Side Connections**—3/4" (19mm) NPT tappings allow easy connections for space heating applications (Potable water only).
- **Insulation System**—2" (51mm) Non-CFC foam insulation covers the sides and top of the tank, reducing heat loss. This results in less energy consumption, improved efficiencies, and jacket rigidity.
- **Pedestal Base.**
- **Water Connections**—3/4" (19mm) NPT factory-installed true dielectric fittings extend water heater life and simplify water line connections.
- **Factory-Installed Heat Traps.**
- **Protective Magnesium Anode Rod.**
- **T&P Relief Valve**—Installed.
- **Low Restrictive Brass Drain Valve**—Durable tamper proof design.
- **Design Certified by CSA International (formerly AGA/CGA).**
- **Complies with the latest Ultra Low NOx requirement (10 ng/J NOx limit).**

3 or 5 Year Limited Tank Warranty / 1-Year Limited Warranty on Component Parts.

For more information on warranty, please visit www.bradfordwhite.com

For products installed in USA, Canada, and Puerto Rico. Some states do not allow limitations on warranties. See complete copy of the warranty included with the heater.

Direct Vent Water Heater

Direct Vent Models

NATURAL GAS

Meet or exceed ASHRAE 90.1b (current standard) C.E.C. Listed
78% Recovery Efficiency

| Model Number | Nominal Gal. Capacity | | DOE Rated Storage Volume (Gal.) | Input BTU/Hr. | First Hour Rating (Gal.) | Uniform Energy Factor | Recovery at 100°F Rise* | | Model Number | Nominal Liter Capacity | DOE Rated Storage Volume (Liters) | Input kW | First Hour Rating (Liters) | Uniform Energy Factor | Recovery at 56°C Rise* | |
|---------------|-----------------------|-----------|---------------------------------|---------------|--------------------------|-----------------------|-------------------------|----------|---------------|------------------------|-----------------------------------|----------|----------------------------|-----------------------|------------------------|--|
| | U.S. Gal. | Imp. Gal. | | | | | U.S. GPH | Imp. GPH | | | | | | | Liters/Hour | |
| ULG2DV50H453N | 48 | 40 | 46 | 45,000 | 83 | 0.63 | 43 | 35 | ULG2DV50H453N | 182 | 174 | 13.2 | 314 | 0.63 | 163 | |

| Model Number | A Floor to C/L of Vent Conn. in. | B Jacket Dia. in. | C Vent Size in. ID / OD | D Floor to T&P Conn. in. | E Floor to Gas Conn. in. | F Floor to Top of Heater in. | G Floor to Water Conn. in. | H Depth in. | J C/L of Water Conn. in. | K Floor to Space Heating Inlet in. | L Floor to Space Heating Outlet in. | M Water Conn. NPT in. | R Space Heating Conn. Size in. | S Gas Conn. Size in. | Approx. Shipping Weight lbs. |
|---------------|----------------------------------|-------------------|-------------------------|--------------------------|--------------------------|------------------------------|----------------------------|-------------|--------------------------|------------------------------------|-------------------------------------|-----------------------|--------------------------------|----------------------|------------------------------|
| ULG2DV50H453N | 75 5/16 | 22 | 4 6 | 58 13/16 | 15 1/16 | 58 13/16 | 61 1/16 | 33 5/16 | 11 | 15 3/4 | 58 13/16 | 3/4 | 3/4 | 1/2 | 201 |

| Model Number | A Floor to C/L of Vent Conn. mm. | B Jacket Dia. mm. | C Vent Size mm. ID / OD | D Floor to T&P Conn. mm. | E Floor to Gas Conn. mm. | F Floor to Top of Heater mm. | G Floor to Water Conn. mm. | H Depth mm. | J C/L of Water Conn. mm. | K Floor to Space Heating Inlet mm. | L Floor to Space Heating Outlet mm. | M Water Conn. NPT mm. | R Space Heating Conn. Size mm. | S Gas Conn. Size mm. | Approx. Shipping Weight kg. |
|---------------|----------------------------------|-------------------|-------------------------|--------------------------|--------------------------|------------------------------|----------------------------|-------------|--------------------------|------------------------------------|-------------------------------------|-----------------------|--------------------------------|----------------------|-----------------------------|
| ULG2DV50H453N | 1913 | 559 | 102 152 | 1494 | 383 | 1494 | 1551 | 846 | 279 | 400 | 1494 | 19 | 19 | 13 | 91 |

Available in Natural Gas only. For 5 year models change suffix from "3" to "5".

* Based on manufacturer's rated recovery efficiency.

Uniform Energy Factor and First Hour Rating is based on the latest AHRI directory listings.

Solid Vent Kit: Part No. 239-51286-00. **Flexible Vent Kit:** Part No. 239-51287-00.

Kits can be ordered and shipped with water heater, or ordered and shipped separately. For vent kit components and venting instructions, refer to Installation and Operation Manual.

Optional Telescoping Solid Vent Kits:

- Kit "F" Telescopes from 4 3/4" to 5 1/16" Part No. 239-42516-00
- Kit "G" Telescopes from 6 1/2" to 9 3/16" Part No. 239-42517-00
- Kit "H" Telescopes from 13 3/8" to 23 1/16" Part No. 239-42514-00
- Kit "I" Telescopes from 49 1/16" to 95 1/16" Part No. 239-42512-00

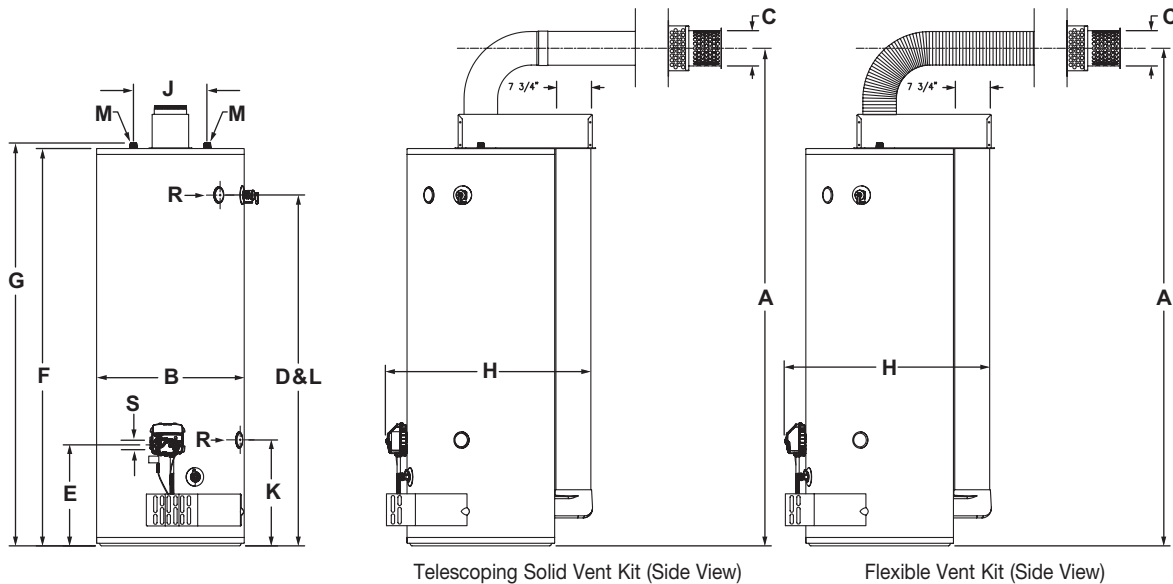

General:

Meets NAECA Requirements.

All gas water heaters are certified at 300 PSI test pressure (2068 kPa) and 150 PSI working pressure (1034 kPa). All potable water connections are 3/4" NPT (19mm). All gas connections 1/2" (13mm). All models design-certified by CSA International (formerly AGA/CGA), ANSI Z21.10.1 and peak performance rated.

Dimensions and specifications subject to change without notice in accordance with our policy of continuous product improvement.

Suitable for Water (Potable) Heating and Space Heating. Toxic chemicals, such as those used for boiler treatment, shall NEVER be introduced into this system. This unit may NEVER be connected to any existing heating system or component(s) previously used with a non-potable water heating appliance.

— BRADFORD WHITE IS —



For field service, contact your professional installer or local Bradford White sales representative.

Sales 800-523-2931 ■ Fax 215-641-1612

Technical Support 800-334-3393 ■ Email techserv@bradfordwhite.com

Warranty 800-531-2111 ■ Email warranty@bradfordwhite.com

International: Telephone 1-215-641-9400 ■ Email international@bradfordwhite.com / www.bradfordwhite.com

Built to be the Best™