

Approval: _____
Customer Signature Required Upon Order

Customer Company Name: _____

1. Shell Side:
 - Max. Allowable Work Pressure: 150psi @ 150F
 - Min. Design Metal Temp.: -20F @ 150psi
 - Capacity: 8.06 ft³
 - Type of Fluid (Non-lethal): WATER / ANTIFREEZE
 - Physical State of Fluid: LIQUID
 - Vessel Stamp: NON CODE
2. Tube Side:
 - Max. Allowable Work Pressure: 225psi @ 150F
 - Min. Design Metal Temp.: -20F @ 225psi
 - Capacity: 3.51 ft³
 - Type of Fluid (Non-lethal): CFC, HFC, HCFC, OIL
 - Physical State of Fluid: LIQUID / VAPOR
 - Vessel Stamp: UM

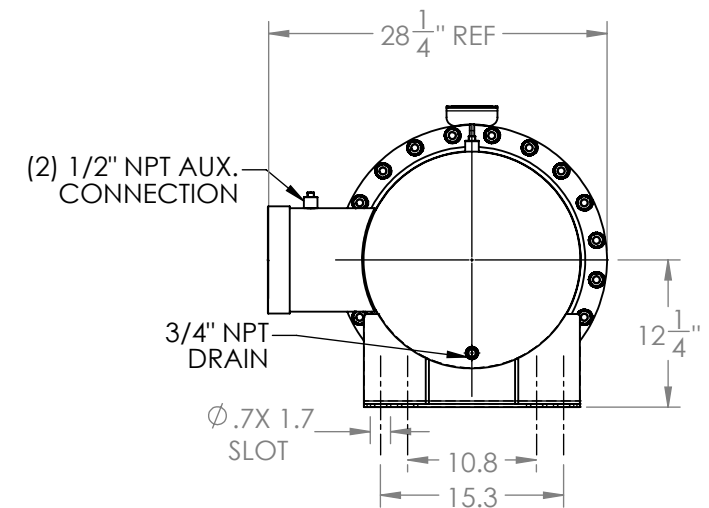
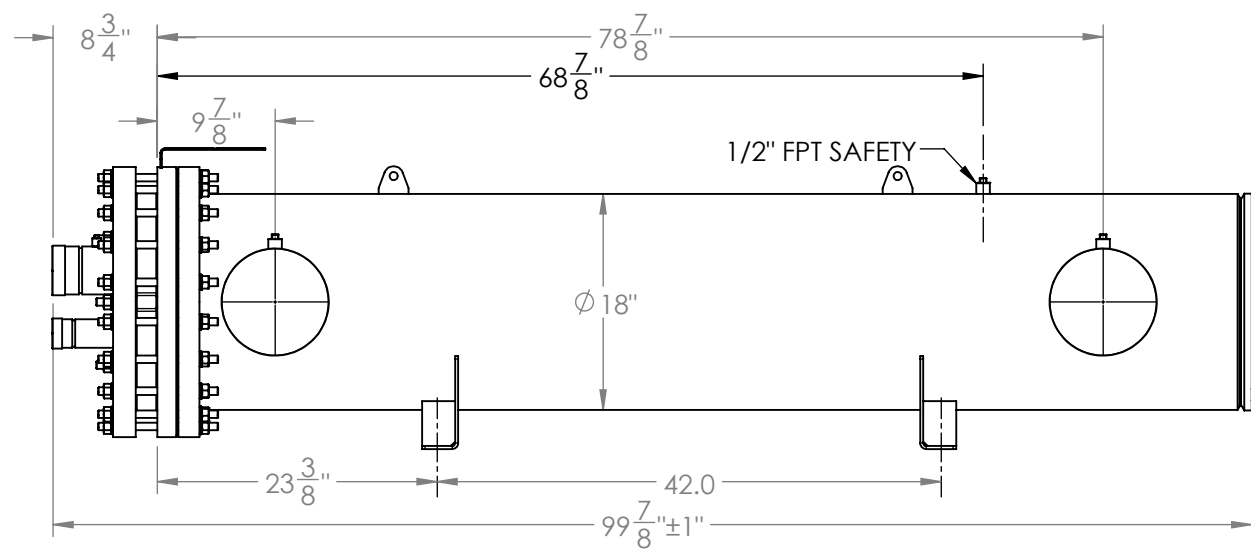
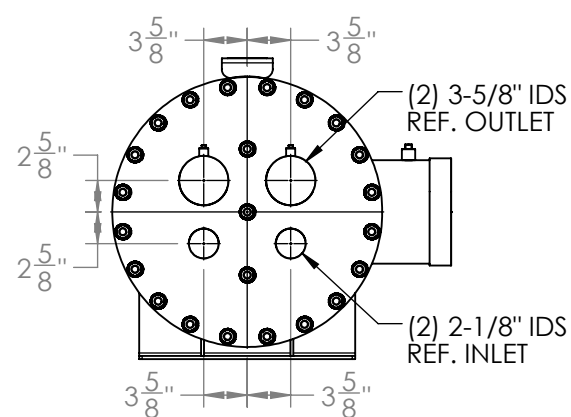
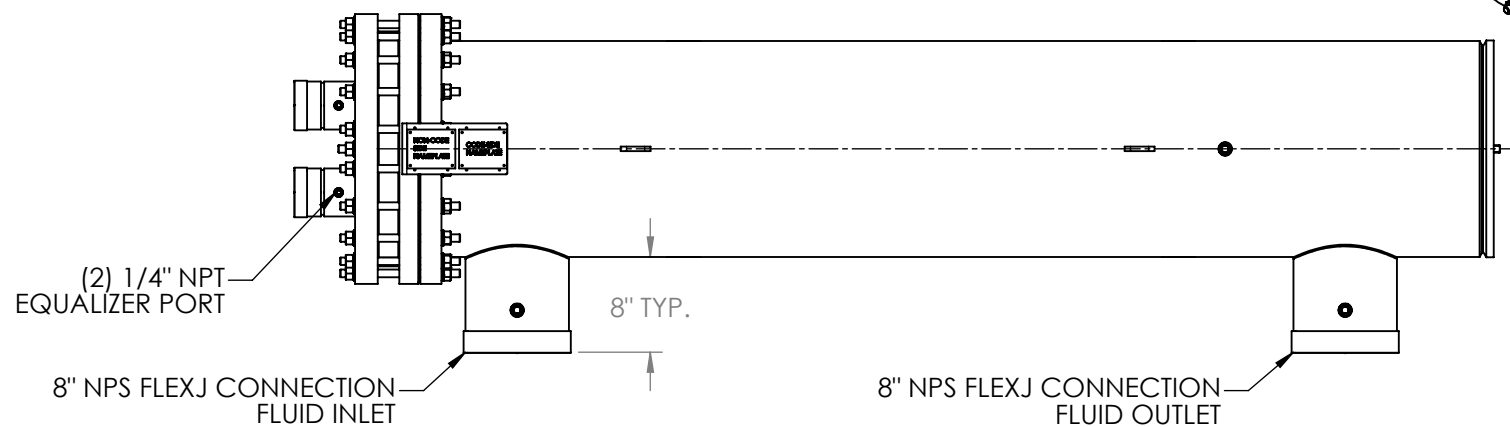
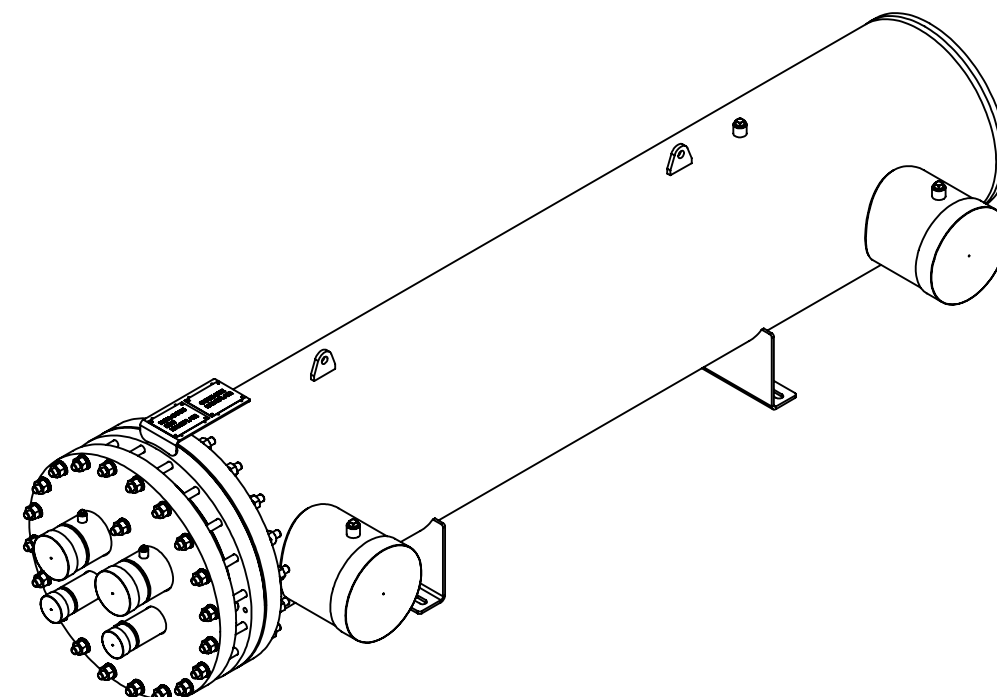

NOTE:

1. STEM250-2NRJXTA TO BE SHIPPED WITH 3/4" INSULATION
2. STEM250-2NRJXXA TO BE SHIPPED WITHOUT INSULATION
3. DIMENSIONS DO NOT INCLUDE INSULATION
4. VESSEL WILL BE PAINTED BLACK
5. THE MATERIAL OF THE TUBE IS COPPER
6. PRESSURE BOUNDARIES ARE CARBON STEEL

PROPRIETARY AND CONFIDENTIAL
THE INFORMATION CONTAINED IN THIS DRAWING IS THE SOLE PROPERTY OF BITZER US. ANY REPRODUCTION IN PART OR AS WHOLE WITHOUT THE WRITTEN PERMISSION OF BITZER US IS PROHIBITED.

VIEW CONVENTION
THIRD ANGLE

ANGULAR TOL ± 2°
FRAC TOL ± 1/4
1 INCH = 25.400000 MM

BREAK SHARP EDGES
THREADS TO BE CLASS 2
DIM & TOL PER ANSI Y14.5M

INCHES	METRIC (MM)
.X ± .125	X.X ± 0.5
.XX ± .063	X.XX ± 0.25
.XXX ± .005	X.XXX ± 0.13

NO	REVISIONS (INDICATED BY Δ)	BY	DATE	JOB#
0	ORIGINAL	JEL	10/22/2013	
1	UPDATE FEET	AC	7/31/2018	
2				
3				
4				
5				
6				

NAME	DATE
DRAWN JEL	10/22/2013
CHECK	
APVD	

TITLE: **APPROVAL DRAWING**

SIZE B	VESSEL NO. STEM250-2NRJX_A	REV 01
SCALE: 1:16		SHIPPING WEIGHT: 1640 lbs