

Approval: \_\_\_\_\_  
Customer Signature Required Upon Order

Customer Company Name: \_\_\_\_\_

1. Shell Side:
  - Max. Allowable Work Pressure: 150psi @ 150F
  - Min. Design Metal Temp.: -20F @ 150psi
  - Capacity: 0.85 ft3
  - Type of Fluid (Non-lethal): WATER / ANTIFREEZE
  - Physical State of Fluid: LIQUID
  - Vessel Stamp: NON-CODE
2. Tube Side:
  - Max. Allowable Work Pressure: 300psi @ 150F
  - Min. Design Metal Temp.: -20F @ 300psi
  - Capacity: 0.42 ft3
  - Type of Fluid (Non-lethal): CFC, HFC, HCFC, OIL
  - Physical State of Fluid: LIQUID / VAPOR
  - Vessel Stamp: UM

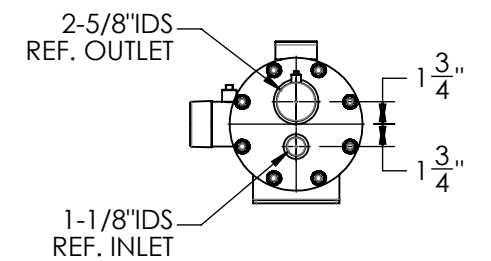
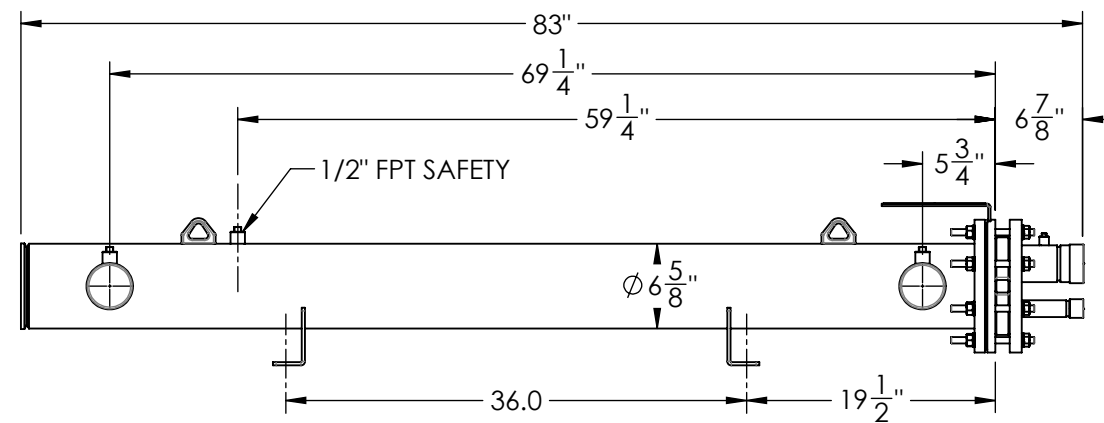
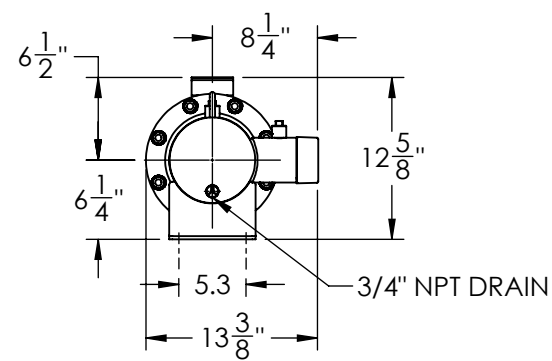
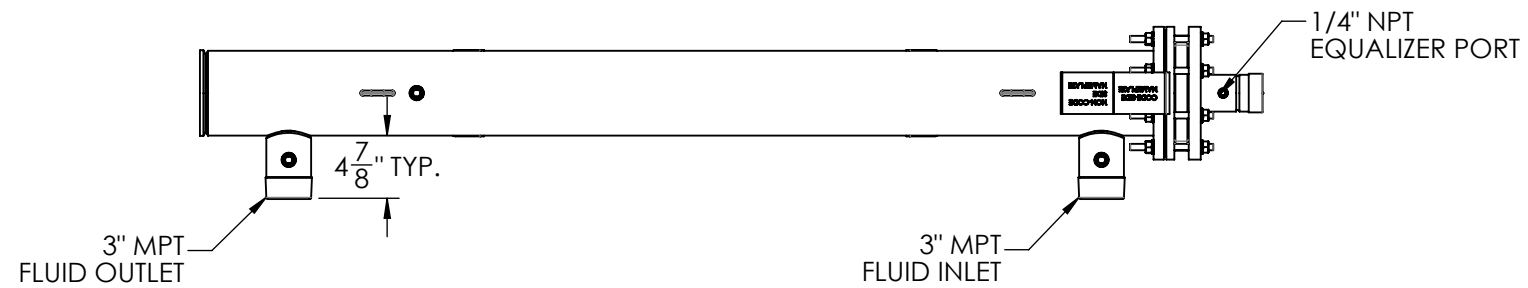
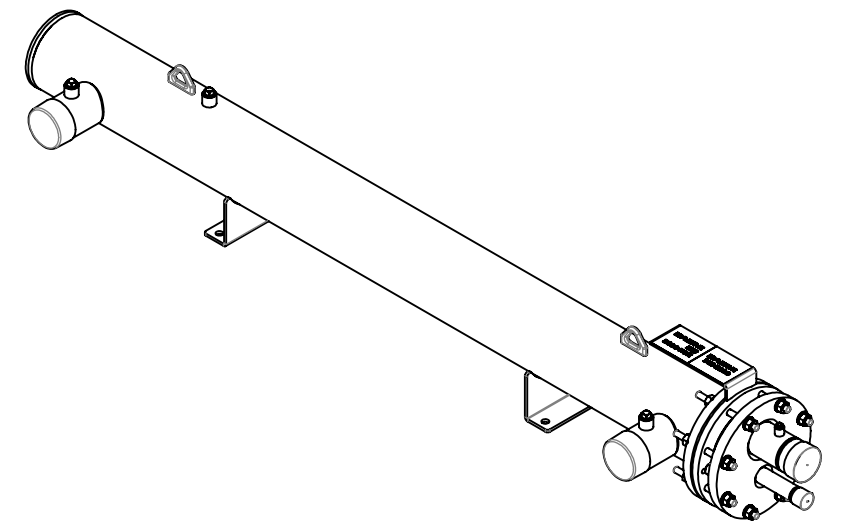

NOTE:  
 1. VESSEL TO BE SHIPPED WITH 3/4" INSULATION  
 2. DIMENSIONS DO NOT INCLUDE INSULATION  
 3. VESSEL WILL BE PAINTED BLACK  
 4. THE MATERIAL OF THE TUBE IS COPPER  
 5. PRESSURE BOUNDARIES ARE CARBON STEEL

**PROPRIETARY AND CONFIDENTIAL**  
 THE INFORMATION CONTAINED IN THIS DRAWING IS THE SOLE PROPERTY OF BITZER US. ANY REPRODUCTION IN PART OR AS WHOLE WITHOUT THE WRITTEN PERMISSION OF BITZER US IS PROHIBITED.

VIEW CONVENTION  
 THIRD ANGLE  
 ANGULAR TOL ± 2°  
 FRAC TOL ± 1/4  
 1 INCH = 25.400000 MM

BREAK SHARP EDGES  
 THREADS TO BE CLASS 2  
 DIM & TOL PER ANSI Y14.5M

|             |        |        |              |
|-------------|--------|--------|--------------|
| INCHES      | X. ± 1 | METRIC | X.X ± 0.5    |
| .X ± .125   |        | (MM)   | X.XX ± 0.25  |
| .XX ± .063  |        |        | X.XXX ± 0.13 |
| .XXX ± .005 |        |        |              |

| NO | REVISIONS (INDICATED BY Δ) | BY  | DATE       | JOB#     |
|----|----------------------------|-----|------------|----------|
| 0  | ORIGINAL                   | JEL | 10/22/2013 |          |
| 1  |                            |     |            | MATERIAL |
| 2  |                            |     |            |          |
| 3  |                            |     |            |          |
| 4  |                            |     |            |          |
| 5  |                            |     |            |          |
| 6  |                            |     |            |          |

TITLE: **APPROVAL DRAWING**

|               |                                   |                          |
|---------------|-----------------------------------|--------------------------|
| SIZE <b>B</b> | VESSEL NO. <b>STEM030-1NLXXTB</b> | REV <b>00</b>            |
| SCALE: 1:15   |                                   | SHIPPING WEIGHT: 356 lbs |