

Approval: _____
Customer Signature Required Upon Order

Customer Company Name: _____

1. Shell Side:
 - Max. Allowable Work Pressure: 350psi @ 250F
 - Min. Design Metal Temp.: -20F @ 350psi
 - Capacity: 5.89 ft3
 - Type of Fluid (Non-lethal): CFC, HFC, HCFC, OIL
 - Physical State of Fluid: LIQUID / VAPOR
 - Vessel Stamp: U
2. Tube Side:
 - Max. Allowable Work Pressure: 150psi @ 150F
 - Min. Design Metal Temp.: -20F @ 150psi
 - Capacity: 1.78 ft3
 - Type of Fluid (Non-lethal): WATER / ANTIFREEZE
 - Physical State of Fluid: LIQUID
 - Vessel Stamp: NON CODE
3. Manufacture vessel in accordance with ASME Sec VIII Div. 1 (Latest Version)
4. Pressure boundary parts are carbon steel / Tubes are copper.
5. All connections will be shipped with caps and plugs.
6. Vessel will be painted black.

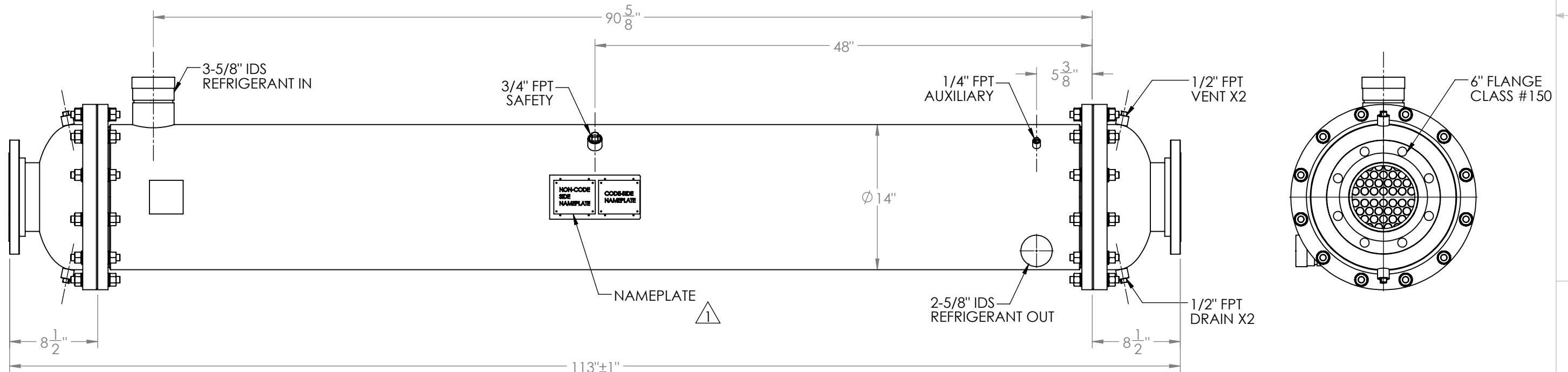
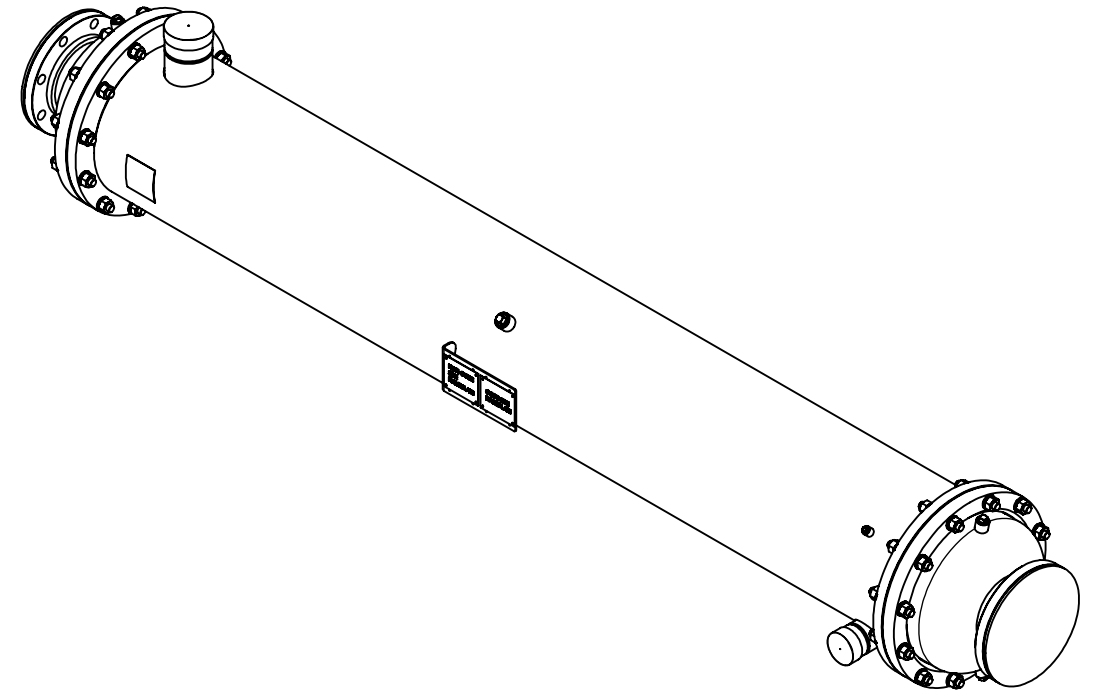

NO	REVISIONS (INDICATED BY Δ)	BY	DATE	JOB#
0	ORIGINAL	JEL	04/30/2013	
1	CORRECTED CPLNG NOTE	CT	5/16/2017	MATERIAL
2	update IDS and nameplate	AC	12/18/2018	
3				NAME
4				DATE
5				DRAWN
6				CHECK
				APVD

TITLE: APPROVAL DRAWING

SIZE	VESSEL NO.	REV
B	STC150XS-XXX	02
SCALE: 1:10		SHIPPING WEIGHT: 797.43 lbs

PROPRIETARY AND CONFIDENTIAL
 THE INFORMATION CONTAINED IN THIS DRAWING IS THE SOLE PROPERTY OF BITZER US. ANY REPRODUCTION IN PART OR AS WHOLE WITHOUT THE WRITTEN PERMISSION OF BITZER US IS PROHIBITED.

VIEW CONVENTION
 THIRD ANGLE

ANGULAR TOL ± 2°
 FRAC TOL ± 1/4
 1 INCH = 25.400000 MM

BREAK SHARP EDGES
 THREADS TO BE CLASS 2
 DIM & TOL PER ANSI Y14.5M

INCHES	METRIC (MM)
.X ± .125	X.X ± 0.5
.XX ± .063	X.XX ± 0.25
.XXX ± .005	X.XXX ± 0.13