

Approval: _____

Customer Signature Required Upon Order

Customer Company Name: _____

1. Shell Side:
 - Max. Allowable Work Pressure: 600psi @ 250F
 - Min. Design Metal Temp.: -20F @ 600psi
 - Capacity: 1.06 ft3
 - Type of Fluid (Non-lethal): CFC, HFC, HCFC, OIL
 - Physical State of Fluid: LIQUID / VAPOR
 - Vessel Stamp: UM
2. Tube Side:
 - Max. Allowable Work Pressure: 150psi @ 150F
 - Min. Design Metal Temp.: -20F @ 150psi
 - Capacity: 0.26 ft3
 - Type of Fluid (Non-lethal): WATER / ANTIFREEZE
 - Physical State of Fluid: LIQUID
 - Vessel Stamp: NON CODE
3. Manufacture vessel in accordance with ASME Sec VIII Div. 1 (Latest Version)
4. Pressure boundary parts are carbon steel / Tubes are copper.
5. All connections will be shipped with caps and plugs.
6. Vessel will be painted black.

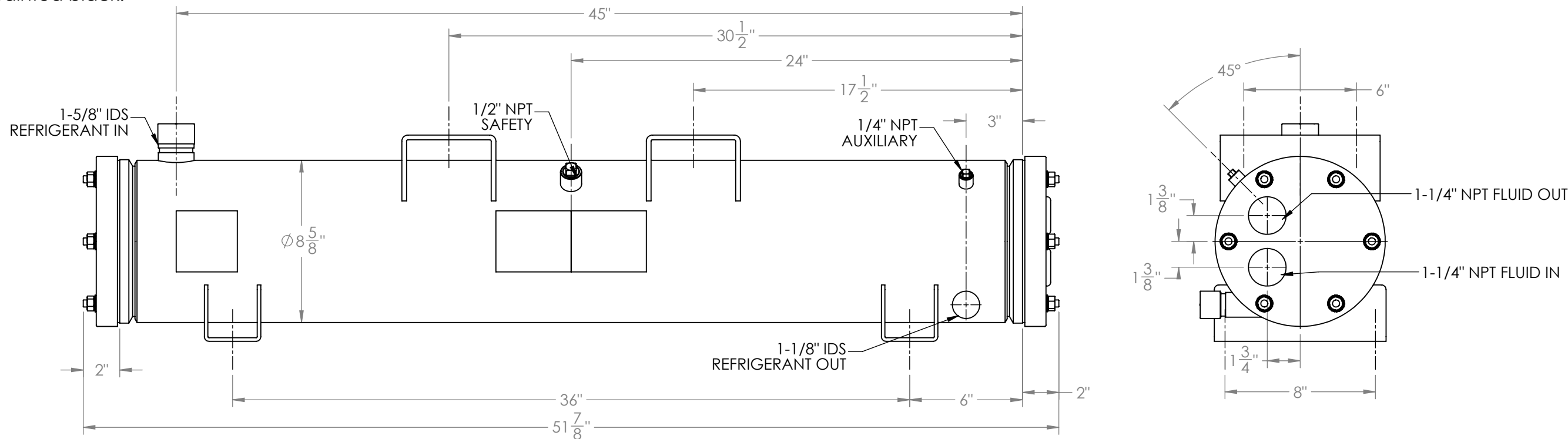
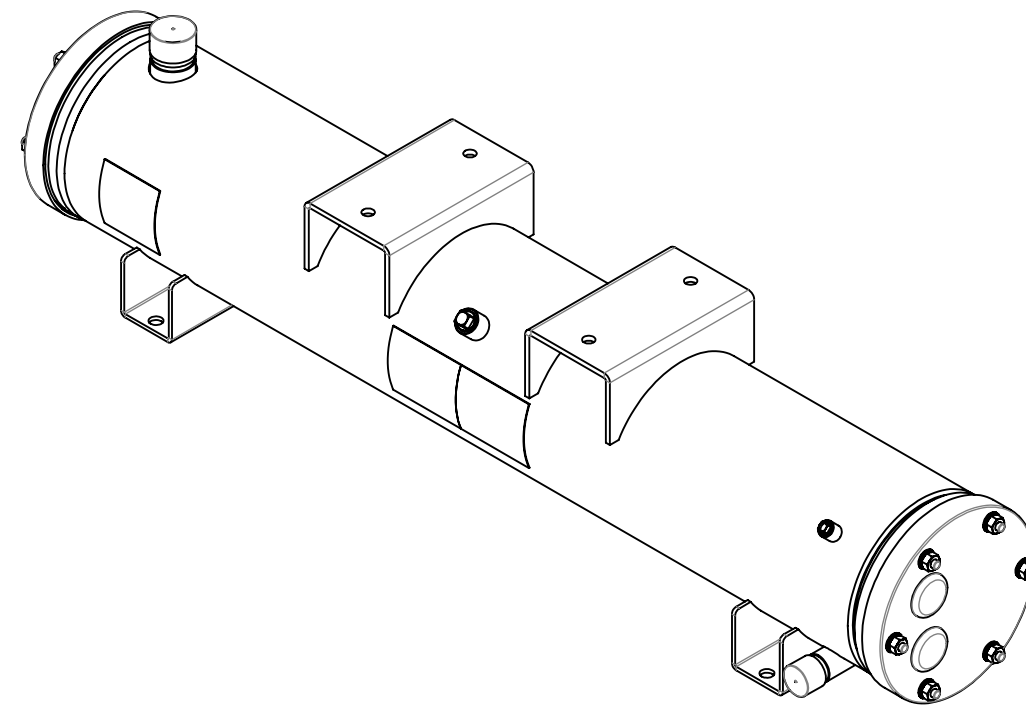

| NO | REVISIONS (INDICATED BY Δ) | BY | DATE | JOB# |
|----|------------------------------------|-----|------------|----------------------|
| 0 | ORIGINAL | JEL | 06/11/2013 | |
| 1 | | | | MATERIAL |
| 2 | | | | |
| 3 | | | | NAME DATE |
| 4 | | | | DRAWN JEL 06/11/2013 |
| 5 | | | | CHECK |
| 6 | | | | APVD |

| | | |
|-------------------------|-----------------------------|--------|
| | | |
| TITLE: APPROVAL DRAWING | | |
| SIZE B | VESSEL NO. HPC020HS-XLX | REV 00 |
| SCALE: 1:6 | SHIPPING WEIGHT: 180.37 lbs | |

PROPRIETARY AND CONFIDENTIAL
 THE INFORMATION CONTAINED IN THIS DRAWING IS THE SOLE PROPERTY OF BITZER US. ANY REPRODUCTION IN PART OR AS WHOLE WITHOUT THE WRITTEN PERMISSION OF BITZER US IS PROHIBITED.

VIEW CONVENTION
 THIRD ANGLE

BREAK SHARP EDGES
 THREADS TO BE CLASS 2
 DIM & TOL PER ANSI Y14.5M

| | | | |
|-------------|--------|-------------|-----------|
| INCHES | X. ± 1 | METRIC | X.X ± 0.5 |
| .X ± .125 | | .XX ± 0.25 | |
| .XX ± .063 | | .XXX ± 0.13 | |
| .XXX ± .005 | | | |

ANGULAR TOL ± 2°
 FRAC TOL ± 1/4
 1 INCH = 25.400000 MM