

S.A.T.

LIST PRICE \$5.00

BCS

POWER UNITS

& Gardening Attachments of the 90's

SERIES **600 & 700**

OWNERS

Use & Care

MANUAL



READ THIS OWNER'S MANUAL
BEFORE ATTEMPTING TO
OPERATE ANY OF THE POWER
UNITS OR ATTACHMENTS

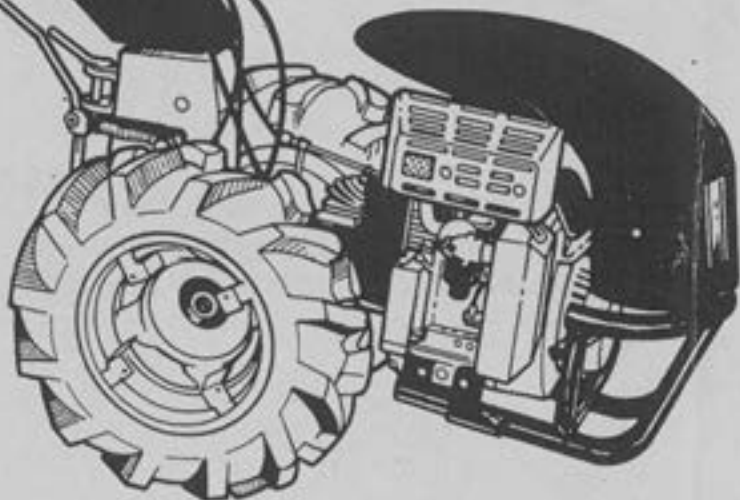
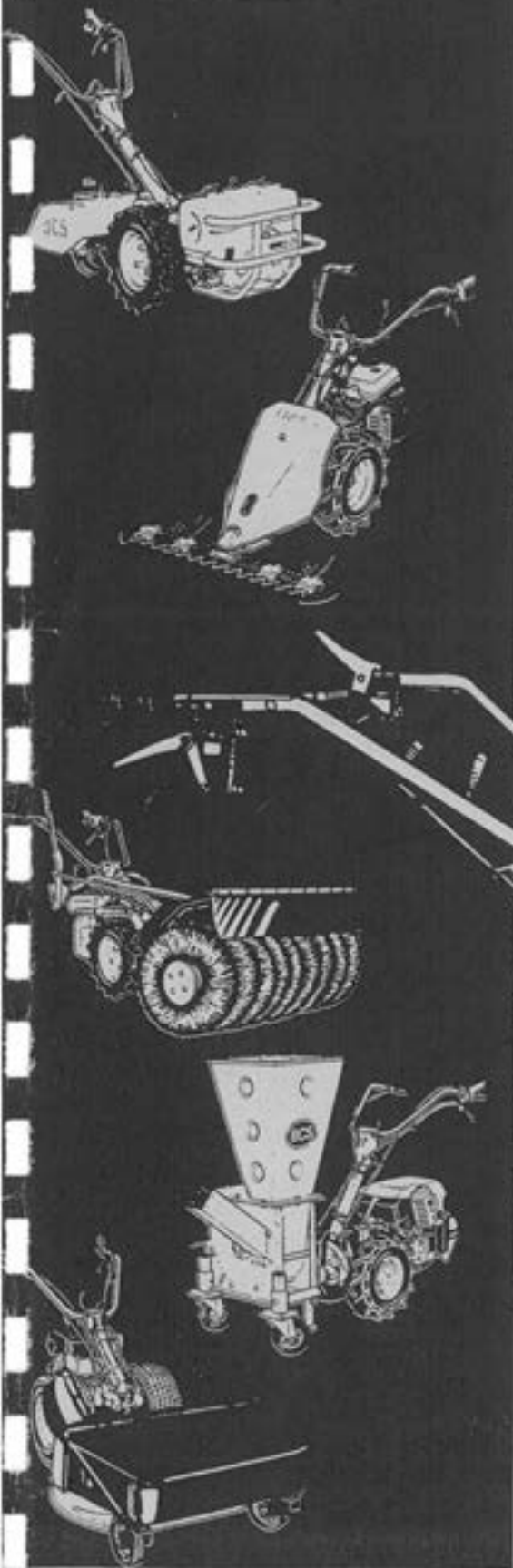

Dear Customer:

Thank you for your purchase. Get set to enjoy the benefits your wise selection of a BCS unit has earned for you. We believe that no other make machine that can handle so many lawn and garden tasks with such fine results — and with so little effort on your part.

Your BCS unit has precision gearing for lasting, trouble-free service. There are no drive belts to stretch and break.

Our network of BCS distributors and servicing dealers stands ready to supply your needs for attachments, accessories, parts and service. With a yearly check-up, your dealer can help you keep your BCS equipment in top shape. Meanwhile, be sure to follow the operating and maintenance tips in this owner's manual for satisfied performance of your machine.

BCS America Inc.

MODELS IN THIS EDITION

This 1990 edition of the owner's manual covers models of the 600 and 700 series produced from late 1989, and models introduced to the series during the year 1990. BCS America maintains a dynamic updating policy. It notifies the field of the serial number of the first unit off the line after a change.

This edition covers the models and model options listed in the specifications on page 15. Accordingly, be sure to record the BCS unit serial number printed between two stars on the transmission, and the engine model and serial numbers from the engine name plate.

GRAPHIC SYMBOLS



This symbol is like a flag. It flags your attention to danger warnings in the manual.



When placed over a picture or an item in the picture, this symbol says "NO!" Do not do, or use or permit whatever is shown.

WARNING

READ ALL SAFETY RULES AND OPERATING AND MAINTENANCE INSTRUCTIONS IN THIS MANUAL BEFORE USING ANY POWER UNIT, ATTACHMENT, OR ACCESSORY.

CONTENTS

Section One

Rules for Safe
Operation of
Unit and
Attachments

General Precautions and Instructions	5
Rear-Tine Tiller Precautions	8
Rotary Mower Precautions	9
Cutter Bar Mower Precautions	10
Power Sprayer Precautions	11
Chipper/Shredder Precautions	12
Power Sweeper Precautions	13

Section Two

Preparing
for Use

Model Configurations	14
Specifications	15
Features	
Model 605	16
Model 737	17
Models 715, 725 & 745	18
Model 602	19
Unpacking	20
Assembling the Unit	20
Lubrication, Filters and Fuel	24
Gasoline Engine Fuel	25
Starting and Stopping	26
Setting Controls for Cold Starting	27
Cranking to Start	27
Stopping	28
Differential and Two-Wheel Drive	28
Wheel Brakes	28
Shut-Down	29
Taking Control of the Machine	29
Gear and PTO Engagement	29
Making a Conversion	30
Operating in Converted Mode	31
Maintenance Program	32

Section Three

Use and Care
of Attachments

Lubrication of Attachments	33
Coupling Attachment to PTO	33
Use and Care of Rear-Tine Tiller	34
Preparing New Tiller	34
Width of Tilt	34
Tilling Depth Adjustment	34
Gardening Suggestions	35
Transport Sulky for Rear-Tine Tiller	35
Use and Care of Cutter Bar Mower Attachments	36
General Cutter Bar Mower Information	36
Recommended Operation	36
Mower Bar Maintenance	36
Use and Care of 2-Blade Rotary Mower	38
700 Series Units Converted for Mower Use	38
Assembly, Connection and Leveling	38
Lubrication	39
Rotary Mower Operation	39
Inspection and Maintenance	40
Use and Care of Snow Throwers	41
General Information	41
Snow Thrower Operation	41
Use and Care of Chipper/Shredder	42
Chipper/Shredder Maintenance	42
Use and Care of Power Sweeper	43
Operation	43
Maintenance and Storage	43
Use and Care of Dozer Blade	44

RECORD OF SERIAL NUMBERS

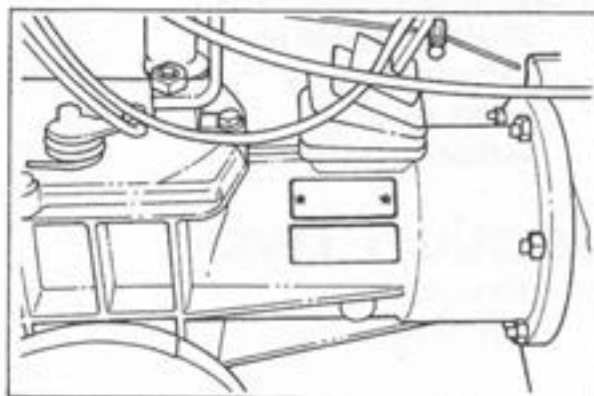
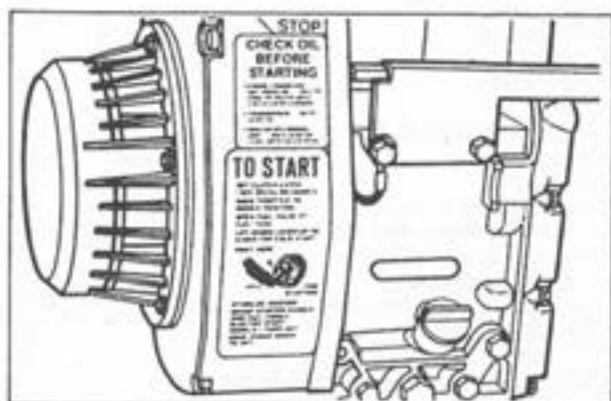

BCS UNIT SERIAL NUMBER * _____
(Located between stars on transmission)

BCS ENGINE SERIAL NUMBER _____
(Stamped on crankcase about two inches from name plate
on side of engine)

KOHLER ENGINE NUMBERS

(Three required numbers on name plate)

MODEL NO. _____

SPEC. NO. _____

SERIAL NO. _____

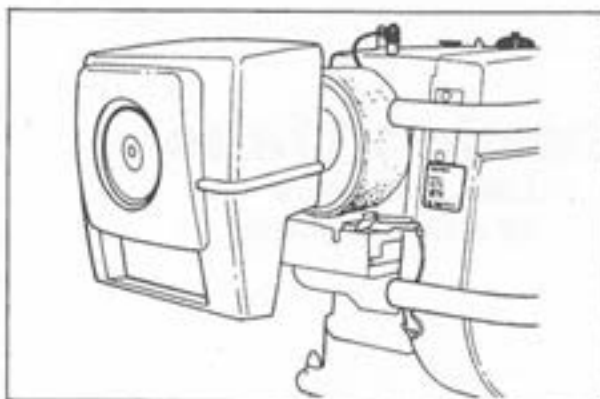

LOMBARDINI ENGINE SERIAL NUMBER _____ (Located on engine name plate)

⚠WARNING

READ ALL SAFETY RULES AND OPERATING AND MAINTENANCE INSTRUCTIONS IN THIS MANUAL BEFORE USING ANY POWER UNIT, ATTACHMENT, AND/OR ACCESSORY.

SECTION ONE

INSTRUCTIONS FOR SAFE OPERATION OF BCS POWER UNITS AND ATTACHMENTS

General precautions and instructions are followed by specific precautions for each combination of attachment and power unit in the owner's manual.

GENERAL PRECAUTIONS AND INSTRUCTIONS

TRAINING

READ THIS OWNER'S MANUAL PRIOR TO OPERATING THE POWER UNITS AND ATTACHMENTS. BCS power units and attachments are designed for operation by properly instructed adults only. Make certain that any person operating this equipment has read this manual.

DO NOT LET CHILDREN OPERATE THE POWER UNIT.

KEEP THE OPERATING AREA CLEAR OF PEOPLE AND ANIMALS. BE CAREFUL THAT CHILDREN DO NOT COME NEAR.

During storage, and whenever the power unit is unattended, disengage the PTO (power take-off) and render the engine unstartable by disconnecting the spark plug wire from the spark plug.

PREPARATION

Wear appropriately protective clothing and safety protection articles for the climate and type of attachment you are to operate.

1. For all walk-behind applications, wear sturdy non-slip boots or safety toe shoes. See recommendations listed for use of a particular attachment. Do not wear open-toed sandals or go barefoot when operating these machines.
2. Wear snug-fitting protective clothing which allows freedom of movement without being loose-fitting. Ties, scarfs and jewelry which could be caught in the machinery should not be worn.
3. Wear hearing protection.
4. Wear eye protection when operating a snow-thrower, power sprayer, chipper/shredder or mower attachment.
5. Overexposure to sunlight can be damaging to your eyes and skin. When working in strong sunlight, protect your eyes with sun glasses, and either keep your body covered or apply a sun screen lotion.

Do not operate on terrain where you cannot maintain good footing, or where the machine could overturn or slide into you. When walking behind the unit, walk slowly, DO NOT RUN!



ONLY PROPERLY INSTRUCTED PERSONS
SHOULD USE THIS EQUIPMENT

KEEP CHILDREN AWAY



EYE AND HEARING
PROTECTION



STURDY FOOTWEAR



DON'T KEEP FUEL OR FUELED ENGINES WHERE SPARKS COULD CAUSE FIRE OR EXPLOSIONS



DO NOT SMOKE OR BRING ANY FLAME OR SPARKS NEAR FUEL!

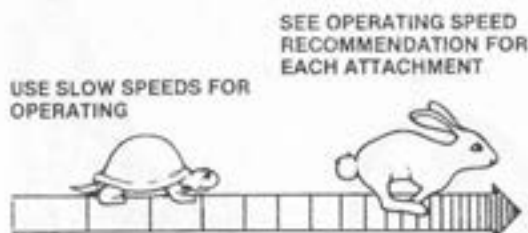

USE SLOW SPEEDS FOR OPERATING

SEE OPERATING SPEED RECOMMENDATION FOR EACH ATTACHMENT



NEVER PUT HANDS OR FEET UNDER MOWER DECK OR INTO OPENING

Thoroughly inspect the area where you are going to mow or thatch the lawn, sweep walks or drives, or throw snow. Remove toys, stones, bones, wires, glass, newspapers and other objects which could be caught up and thrown by the machine.

Take the following precautions for the safe handling and storage of fuel:

1. Keep fuel supplies in approved type, properly labeled fuel containers.
2. Do not store fuels or fueled units in closed (unventilated) areas, or in garages or shops connected to human living quarters. Do not store units or fuel where there are flames or sources of sparks such as electrical appliances and switches.
3. Obey all local regulations for the storage and handling of fuel.
4. Do not smoke when fueling, or fuel where the fumes could be ignited by fire or sparks.
5. Do all fueling outdoors over non-flammable surfaces. If fuel is spilled on the unit, wipe the unit dry and properly dispose of the wiping rag. **ALWAYS MOVE THE UNIT AT LEAST 10 FEET (3m) AWAY** from the fueling spot and fuel supplies before starting the engine.
6. Always remove the engine fuel cap very slowly to equalize tank pressure and avoid spurting of fuel. Keep your face and eyes away from the tank while loosening the fuel cap.
7. Do not fuel a running or hot engine. Do not loosen the fuel cap until the engine has stopped. Then wait several minutes for the engine to cool before pouring fuel.

Before starting the engine, put all control levers in neutral (N) position. All "N" positions on the gear selector are neutral. Also be sure to disengage the PTO (power take-off) to the attachment.

Never make blade height or any other adjustment to the power unit or any attachment while the engine is running.

OPERATION

Operate only when there is good visibility. Do not operate at dusk or at night. Do not operate when it is foggy or hazy.

Never change the engine governor setting or overspeed the engine. Use the throttle and gear settings recommended for particular attachments and applications in this owner's manual.

Do not put hands and feet under the mower deck or into the discharge openings of a rotary mower.

Do not put fingers or any other part of the body into the intake or discharge openings of any mower, snow-thrasher, or chipper/shredder unless you have disconnected the spark plug wire so the engine cannot be started accidentally. Keep the machine clean-out holes closed. Stay out of the discharge stream of a mower, chipper/shredder, power sweeper or power sprayer.

Always stop operation of a rotary mower, a cutter bar mower, snow thrasher, or a tiller before crossing paved or gravel roadways.

Never ride the tractor or an attachment. Ride only on riding accessories designed for the purpose. Do not take children on a sulky with you.

1. Use **transport sulkies** only for transport to and from the operating area, and never for operation.
2. Use **utility wagons** only for hauling, and limit the payload to the rated capacity of the wagon.
3. A **mowing sulky** is exclusively for operation of a rotary mower and must not be used with any other attachment.
4. Never use ride-on attachments on the highway or any city street.

Do not disconnect or otherwise defeat the purpose of the lockout devices on the 700 series of units. The high-speed lockout prevents using too fast a gear for backing up a front-mounted attachment. The PTO/REVERSE lockout permits backing up a rear-mounted attachment only when the PTO is disengaged. Read Section Two for explanation of the lockout devices. [Lockouts not required on model 602.]

Do not use the highest numbered gear on the gear selector when walking behind the machine. On all units in this manual, the highest gear produces much faster than walking speed, and is only to be used for transport in conjunction with a transport sulky.

Do not make adjustments or repairs to the machine when the engine is running. Put all controls in neutral, wait until reciprocating or rotating parts of the attachment have stopped, and disconnect the spark plug wire:

1. Before leaving the unit where unauthorized persons may start it accidentally.
2. When a foreign object has been struck or taken into the attachment. Proper operation should be restored before further use.
3. Before cleaning out a clogged attachment such as a rotary mower, cutter bar mower, snow-thrasher, chipper/shredder or power sweeper.
4. If the machine suddenly starts to vibrate or run erratically. The entire machine should be inspected by an authorized BCS servicing dealer before further use.

All safety guards, plates, lockouts, deflectors and shields must be in proper position. Do not operate if any safety devices or fastening parts are missing from the unit.

Do not run the engine indoors where deadly poisonous carbon monoxide fumes can collect. If the engine is to be started inside a garage or barn, open the doors and windows wide so the fumes can escape.

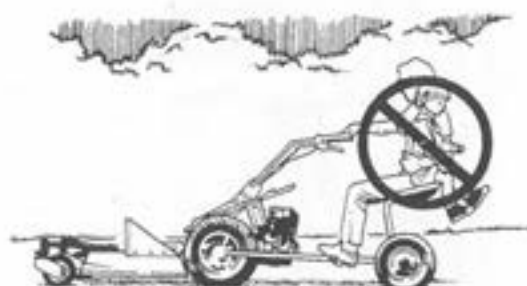

DO NOT LET CHILDREN RIDE WITH YOU ON A SULKY

HIGH SPEED LOCKOUT IN LOCKOUT POSITION

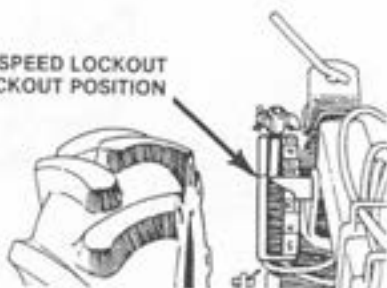

DO NOT OPERATE IF MACHINE STARTS TO VIBRATE



UNIT SERVICING SHOULD BE DONE BY AUTHORIZED BCS DEALERS



BUILD-UP OF FUMES CAN BE VERY DANGEROUS



DON'T ATTEMPT REPAIRS NOT COVERED IN THIS OWNER'S MANUAL

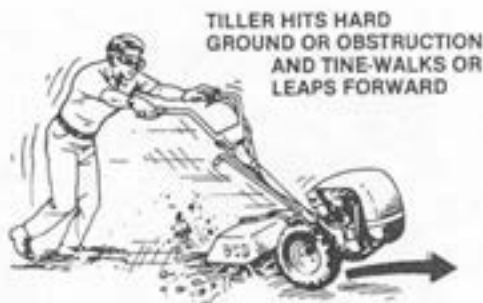
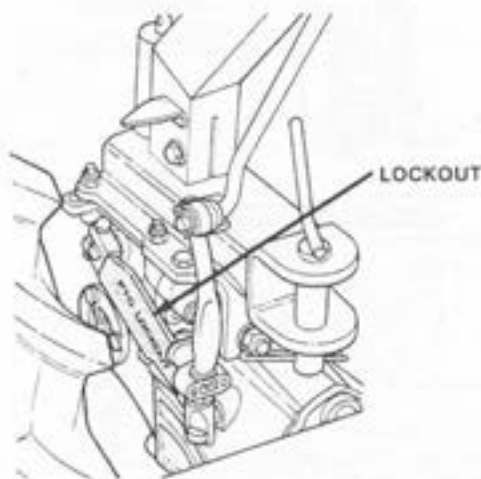

MAINTENANCE AND STORAGE

Keep engine, tractor and all attachments in safe working condition.

Clean the unit and accessories at regular intervals, also check for damaged or missing parts. Check the tightness of all fasteners.

Perform the items of maintenance recommended in this owner's manual. Do not attempt any disassembly and repairs for which instructions have not been furnished. Certain engine adjustments, and internal servicing of the engine, tractor, clutch and transmission, and gearboxes of attachments should be done only by a BCS-trained serviceman at an authorized BCS servicing dealer or distributor.

Do not store the machine with fuel in the system. Disconnect the fuel line at the carburetor inlet, and drain the fuel into a fuel container. Then reconnect the fuel line. Start and run the engine until it stops from lack of fuel.

When storing the machine, use the spring latch (illustrated on page 27) to latch the clutch lever in the depressed (disengaged) position. This prevents the clutch cone from sticking to the lining during storage.

Store the machine in a well-ventilated place, protected from dampness and the weather.

REAR-TINE TILLER PRECAUTIONS

The 700 series tractor models and the model 605 have **PTO/reverse lockout** devices to prevent tine rotation while the Tiller is being backed up. These devices are shown and their operation described on page 26. Before operating the Tiller, always check that the lockout device is properly assembled on the machine. **Do not remove the high speed lockout or render it inoperable.**

Do not put hands or feet near or under the tiller housing. Keep away from the rotating tines. The tines of the BCS tiller rotate at high speeds independent of the tractor gear speed settings.

Inspect the area to be tilled. Pick up rocks and other objects of a size which may jam or otherwise interfere with tiller operation.

Till only when there is good light.

Use caution to avoid slipping and falling. Wear footwear which will improve footing on slippery surfaces.

Do not overload the machine by attempting to till too deeply or in fast forward. See tiller operation instructions in Section 3.

On new (previously untilled) or hard, rocky ground, use lowest gear and throttle settings, and set the tiller tines for minimum soil penetration. Be alert for the possibility the machine may leap forward if the tines contact an underground obstruction. If this occurs, let go of the tiller handles to stop the engine.

Do not use makeshift accessories in conjunction with the tractor and tiller. Use only wheels, counterweights, shaft extensions, connectors, and tine combinations recommended for each tractor and tiller attachment by BCS.

The highest number gear selection is only for transport of the unit and tiller attachment in conjunction with a **transport sulky**.

Do not operate the tiller in high gear. Do not use high transport speeds on slippery surfaces. When using a transport sulky, look behind and use care when backing.

ROTARY MOWER PRECAUTIONS

IMPORTANT NOTICE

Do not deactivate the **PTO Reverse Lockout** on any of the convertible models in this 600/700 series owner's manual. The new design lockouts on these models automatically disengage during a conversion for front-mount attachments.

Clear the area to be mowed of all objects (wires, rocks, toys, etc.) which might be picked up and thrown by the mower.

Disengage the PTO and put the transmission into neutral (gear selector position "N") before cranking to start the engine, and also whenever leaving the operator zone behind the handlebar or dismounting from a sulky.

Stay alert for holes, rocks, roots in the terrain and other hidden hazards. Keep away from drop-offs.

Use wheel extensions for added stability of a walk-behind mower. When walking behind, be especially cautious when changing direction on slopes.

When operating from a riding sulky, reduce speed and use extreme caution on slopes and in sharp turns to prevent tipping and loss of control.

MOW SLOPES AS FOLLOWS:

1. When riding, mow up and down, never across the slope.
2. When walking behind, mow across the slope, never up and down.
3. Do not mow excessively steep slopes.

Be careful not to discharge grass in direction of roadways, houses, vehicles and people.

Inspect grass bags frequently for wear and deterioration. Replace grass bags which are not in good condition.

When the **2-blade mower** is used without the grass bag, the grass deflector **must** be in the down position covering one discharge volute, and the door on the other volute **must** be closed, to prevent open discharge from the volutes. When mounting the grass bag on the deck to collect the cuttings, open the door and raise the deflector for discharge from the volutes into the bag.

Before removing the grass bag for emptying, disengage the PTO, shut off the engine and wait until the mower blades have stopped.

Never put hands in any openings of the mower or grass bag when the engine is running. If necessary to clear out the discharge chute with your hands, always first disconnect the spark plug wire.

Keep the mower blades in good condition. Inspect, sharpen and maintain blades as recommended for mower attachments in Section 3. Replace bent, badly worn blades, because pieces breaking off can become projectiles. After sharpening, blades should be balanced.

USE ONLY IN CONJUNCTION WITH TRANSPORT SULKY



DO NOT MOW WITH GRASS DEFLECTORS OPEN

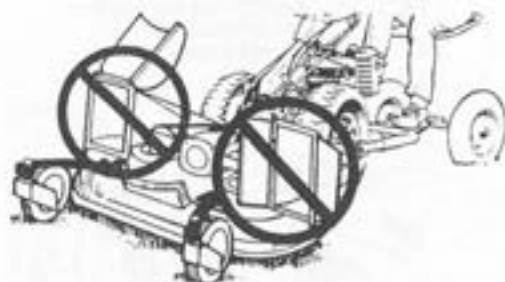

WHEN RIDING, MOW UP AND DOWN SLOPES



WHEN WALKING BEHIND, MOW ACROSS THE SLOPES

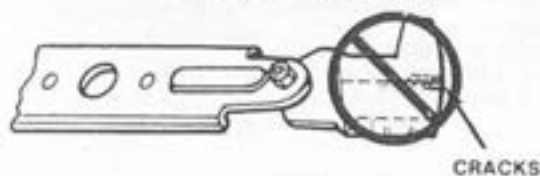

CRACKS



MOW ACROSS THE FACE OF A SLOPE

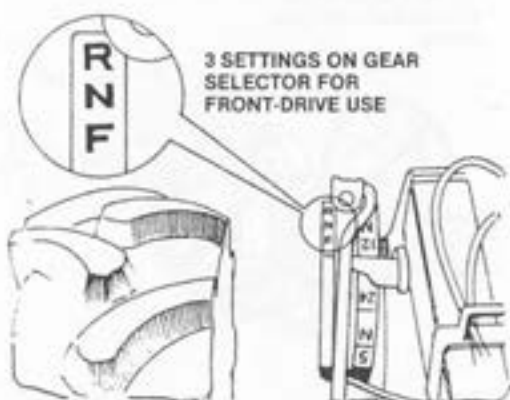

3 SETTINGS ON GEAR SELECTOR FOR FRONT-DRIVE USE



OPEN DOORS WIDE IF STARTING THE ENGINE INDOORS



CLEAN SNOW THROWER AFTER USE OR THAW IN A WARM PLACE

IMPORTANT NOTICE

Do not deactivate the **PTO Reverse Lockout** on any of the convertible models in this 600/700 series owner's manual. The new design lockouts on these models automatically disengage during a conversion for front-mount attachments.

CUTTER BAR MOWER PRECAUTIONS

Cutter Bar Mower attachments are intended for walk-behind operation only. Do not use a riding sulky.

Mow only at a slow rate of speed. See page 36 for recommended throttle and gear combinations for cutter bar mowing. Do not use (transport) gear #3 on model 602, or gear #4 on 605 for any purpose other than using a transport sulky for transport. Transport speed of these models far exceeds the walking speed of an operator. When converted to drive the cutter bar, models 715, 725 and 745 have only three settings — F (forward), N (neutral) and R (reverse) available for use. The high speed lockout blocks the other positions on the gear selector.

A model 737 converted for cutter bar operation has fourth gear position blocked by a high speed lockout. **Do not remove or otherwise defeat the purpose of the high speed lockout device.** Disengage the PTO when backing the machine.

Cutter bar mowers are designed for mowing over terrain which is too rugged or steep for use of rotary mowers. Use care when mowing hilly terrain. Always mow across the face of a slope, never up and down. Use wheel extenders for added stability. Do not mow excessively steep slopes. Go slowly and carefully on all turns.

SNOW THROWER PRECAUTIONS

Wear protective, trim fitting winter clothing with no scarfs or draw strings which could be caught in the machinery. Wear boots or shoes designed to improve your footing on slippery surfaces. Wear proper eye protection.

When necessary to start the engine indoors and drive the machine out of the building, keep the doors and windows wide open. Exhaust fumes can be dangerous.

Never put your hands into the discharge opening or impeller/collector when the engine is running. Always disengage the PTO, shut off the engine, and wait until all moving parts have stopped before doing the following:

1. Cleaning or deicing the impeller/collector and discharge chute. (If possible, detach snow-thrower and thaw in a warm, dry place.)
2. After striking a foreign object, thoroughly inspect for damage. Make repairs before further operation.

Never use the snow thrower near glass enclosures, automobiles, window wells, drop-offs, etc., without adjusting the discharge angle away from them.

Keep children, pets and observers away.

POWER SPRAYER PRECAUTIONS

Always read and follow the information and instructions for the application of herbicides, fungicides, insecticides and fertilizers obtained from the labels of such products or from the manufacturer. In addition, advice on chemicals approved for use in your area can be obtained from your local county agent. Be sure you know the proper application rate for any chemical you wish to spray.

Inspect the sprayer before each use. The sprayer develops high pressure, so be sure all pressure lines and connections are in good condition.

Choose windless days for the spraying of any chemical considered hazardous. Do not spray where drift could contaminate people, animals or property.

When applying any substance dangerous if breathed in, or absorbed through the skin, wear adequate protection. This should include rubber gloves and boots, goggles, respirator masks, caps, and clothing to cover as much of the body as possible. Cotton articles are suggested for their launderability as well as high absorbency. After the spraying of any hazardous substance, remove clothing articles for laundering, and immediately take a thorough soap-and-water shower before residues have time to enter your body.

Before spraying, always prepare for proper wash-down of equipment.

Never allow passengers to ride the sprayer.

The pressure at the discharge nozzle is as high as 300 psi. The spray can penetrate the skin and cause severe blood poisoning. Do not put hands into the discharge stream. Do not direct spray at people or animals.

Unless the manufacturer of the chemicals claims that certain products can be combined for application, spray only one chemical at a time. Flush the sprayer tank before changing sprays.

Always hose down the equipment and flush the sprayer tank after each use. Select an area where the run-off will not contaminate ground water. Do not dump into ditches and storm sewers.



READ DIRECTIONS
ON LABEL OF
SPRAY PRODUCT

DON'T SPRAY
ON WINDY DAYS



TAKE A SOAP AND
WATER SHOWER
IMMEDIATELY AFTER
SPRAYING



WEAR EYE PROTECTION GOGGLES

DO NOT WEAR THINGS WHICH COULD BE CAUGHT AND PULLED INTO THE HOPPER



DO NOT GO ON DISCHARGE SIDE WHEN THE CHIPPER/SHREDDER IS RUNNING



CHIPPER/SHREDDER PRECAUTIONS

Read all instructions in this owner's manual, plus detailed instructions in the Chipper/Shredder owner's manual.

Material may be thrown out of the intake or discharge openings at high velocity. Wear safety eye protection goggles stamped "Z87" (for ANSI Standard Z87). Also wear a hat.

Wear trim-fitting articles of clothing with no dangling ties, laces, chains, etc. Remove rings, bracelets and wrist watches before operating the Chipper/Shredder. Gloves may be worn when feeding the Chipper, but remove gloves before feeding material into the Shredder hopper.

Set up the machine on soft, firm ground which provides support and acts as a shock absorber. But, do not set up on hard paved or graveled surfaces which provide no cushion.

Before starting the engine, always look to be sure the Chipper/Shredder is empty.

Do not go on the discharge side when the Chipper/Shredder is running. Do not look into the shredder hopper or place your head over it when feeding material. Do not feed the chipper chute from directly in front, but always stand to the side.

Do not reach into the chipper chute to push through short pieces. Push short ends through with another long branch.

Put only shreddable materials into the hopper. Be careful not to include cloth, string, plastics, glass, rubber, rocks or paving bricks, large wood chunks, metal or long branches or vines. These things are not shreddable, and can cause violent ejection of materials from the Chipper/Shredder.

Do not allow processed material to pile up in the discharge area. A blockage of the discharge can result in kickback of material through the feed opening.

Always disengage the PTO before transporting the unit and attachment. Never leave the machine unattended without putting the controls in neutral and disconnecting the spark plug wire to prevent unauthorized operation.

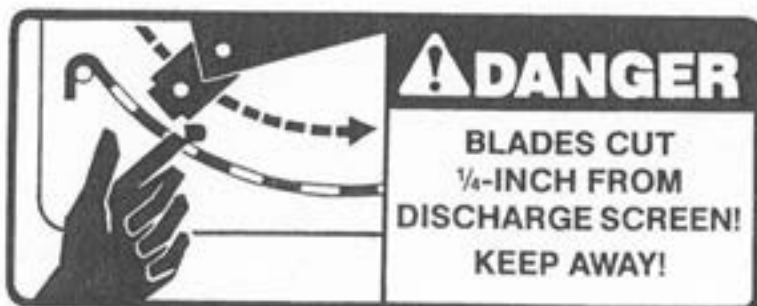

POWER SWEEPER PRECAUTIONS

Follow "General Precautions and Instructions" in Section One of this manual, and all instructions in the Power Sweeper Attachment owner's manual (part number 101.00915) for the safe use of the Power Sweeper.

IMPORTANT NOTICE

Deactivation of the **PTO Reverse Lockout** (see **WARNING** in Sweeper owner's manual) is not to be done on the tractor models in this updated 600/700 series owner's manual. New design lockouts automatically disengage during the conversion of these models for the Sweeper, or any other front-mounted attachment.

Do not put hands, feet or any other part of your body near the Sweeper brush or any other rotating part.

Keep the work area clear of people and pets. Do not let children come near. Be extremely careful on gravel or paved surfaces to direct the discharge away from people and passing vehicles.

Wear a dust mask or respirator for protection when sweeping dusty surfaces.

Wear eye protection goggles stamped "Z87" (for ANSI Standard Z87).

Before transport or storage of the unit, adjust the casters of the Sweeper so the bristles do not touch the ground.

Thoroughly inspect the surface to be swept and remove objects which could be thrown by the Sweeper or cause it to run off course. Remove wires, glass objects, doormats, boards, toys and other obstructions.

Always put the unit in gear before engaging the PTO to power the Sweeper. If the Sweeper bristles engage the ground when the unit is in neutral, the Sweeper will drive back the unit.

On irregular terrain with hillocks, prepare to let go of the controls to stop all motion if the brush suddenly drives the unit backward.

Do not use the Sweeper on any surface where you cannot keep your footing, or the unit could overturn. Walk behind the unit. Disengage the PTO when going up or down a slope. Work across the slope when sweeping or thatching.

If using the Sweeper on rooftops, set up barricades so you will not come too close to the edges. Be sure the surface is dry and does not pitch more than 5 degrees (1/2" per foot).

Do not drive the Sweeper onto frozen lakes or ponds unless the ice is thick and strong enough to support the combined weight of you, the Sweeper and the unit.

WEAR GOGGLES AND
DUST MASK.



KEEP CHILDREN AWAY



PUT UNIT IN GEAR
TO OPPOSE SWEEPER
PUSH-BACK



DO NOT SWEEP ON
ROOFTOPS WITH MORE
THAN A 5° PITCH

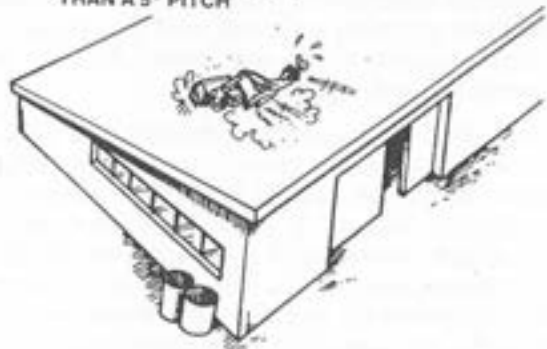

WATCH OUT
FOR THIN ICE

MODEL CONFIGURATIONS

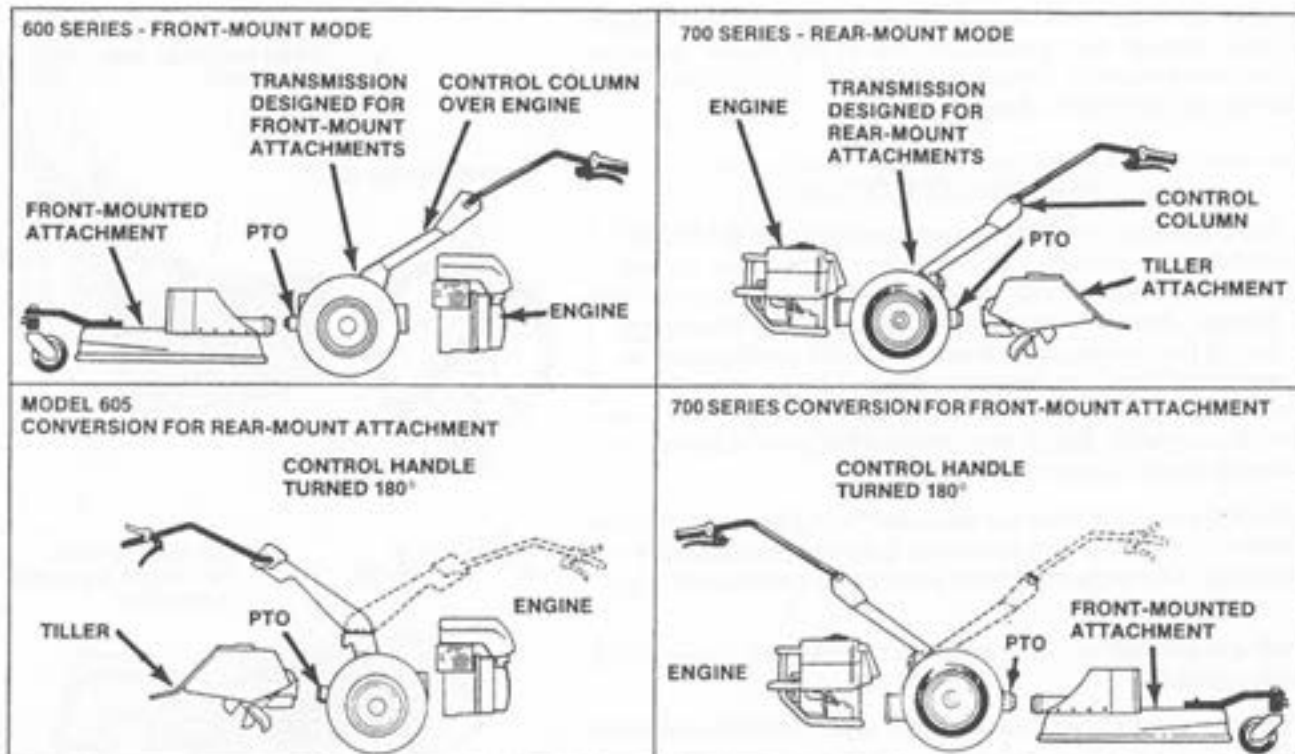

MODELS DESIGNED FOR FRONT-MOUNTED ATTACHMENTS

Models of the 600 series are designed for front-mounted attachments. They have the PTO (power take-off) coupling up front, and the engine and control column at the rear. Model 602 has three speeds **forward** and one **reverse**.

Model 605, a convertible model designed primarily for front-mount attachments, has four speeds **forward** and three speeds **reverse**. Swinging the handlebars around to place them over the PTO coupling at the rear of the unit converts the 605 for rear-mount attachments. The new design transmission automatically changes drive wheel rotation to drive the unit forward in either front-mount or rear-mount mode. Selecting one of three available gear positions on the gear selector, and engaging the **red reverser lever** on the right handlebar backs up the unit in either front-mount or rear-mount mode. The **high speed lockout** blocks selection of gear position #4 for backing up the unit.

MODELS DESIGNED FOR REAR-MOUNTED ATTACHMENTS

All models of the 700 series are designed for rear-mount tillers, and all models are convertible for front-

mount attachments. In the rear-mount mode, the PTO (power take-off) flange and the control column are at the rear and the engine is up front.

Model 715 has three speeds **forward**, one **reverse**. Models 725 and 745 have five speeds **forward**, two **reverse**. Model 737 has four speeds **forward**, three **reverse**.

Swinging the control column around from the PTO end of the unit to the engine end converts it for front-mount attachments. After conversion, all models except 737 will go forward in **reverse** gear, narrowing your choice of speeds for work. A safety high speed/reverse lockout device on the control column blocks the high **forward** speeds, which are too fast for use in backing the unit.

Model 737 has a new type transmission that drives the unit forward when placed in gear — even when converted for front-mount attachments. In either front-drive or rear-drive mode, selecting any gear except #4 (that the **lockout** blocks) and squeezing the **red reverser lever** on the right handlebar backs up the unit. Gear #4 is too fast for backing up the unit.

SPECIFICATIONS

ENGINE AND POWER UNIT

MODEL	602	605	715	725	745	737
Design Type	Pusher	Pusher	Tractor	Tractor	Tractor	Tractor
Convertible	No	To tractor	To pusher	To pusher	To pusher	To pusher
Engine Make	Brigg/Stratton	B/S Vang. 12.5 HP Kohler 8 HP	BR/ST 7 HP BR/ST 5 HP	Kohler Gas/8 HP	Kohler Gas/14 HP	BCS Gas/10 HP
Type	Gas/5 HP	Gas	Gas	Dry Cartridge Standard	Dry Cartridge Standard	Dry Cartridge Optional
Air Filter	Dry Cartridge Optional	Dry Cartridge Optional	Dry Cartridge Optional/Std.			
Prefilter						
Transmission	Precision steel gears	Precision steel gears	Precision steel gears	Precision steel gears	Precision steel gears	Precision steel gears
Differential	No	Yes	No	No	Yes	Yes
Gears	PUSH. TRACT.	PUSH. TRACT.	PUSH. TRACT.	PUSH. TRACT.	PUSH. TRACT.	PUSH. TRACT.
Forward	3 —	4 3*	1 3	2 5	2 5	4 3*
Reverse	1 —	3 3*	1 1	2 2	2 2	3 3*
Speed (mph)						
1st	1.4	0.6	0.6	0.6	0.6	0.7
2nd	2.4	1.6	1.6	1.2	1.2	1.4
3rd	6.8	2.7	6.8	1.4	1.5	2.0
4th	—	7.7	—	2.8	3.0	8.0
5th	—	—	—	6.9	7.1	—
Reverse (1)	1.8	0.7	1.2	0.7	0.7	0.7
Reverse (2)	—	1.7	—	1.7	1.8	1.5
Reverse (3)	—	2.4	—	—	—	2.1
Power Take-Off	[Independent — PTO rpm controlled by throttle setting on all models.]					
PTO rpm/	965/3600	965/3600	965/3600	965/3600	990/3600	965/3600
Engine rpm						
Attaching	2 threaded	2 threaded	2 threaded	2 threaded	3 threaded	2 threaded
Method	studs w/nuts	studs w/nuts	studs w/nuts	studs w/nuts	studs w/nuts	studs w/nuts
Wheels & Tires						
Size	4.0 x 8"	20 x 8.00-10"	4.0 x 8"	4.0 x 8"	6.5/80 x 12"	5.0 x 10"
Tread	Tractor	Turf	Tractor	Tractor	Tractor	Tractor
Track width †	17"	28"	13-20"	13-20"	26"	22"
Weight (lbs.) ‡	137	165	140	160	300	188
Dimensions (in.)						
Height	37"	31"-48"	33"-42"	34"-43"	34"-43"	28"-37"
Width	21"	27"	21"	21"	27"	21"
Length	40"	44"	61"	61"	78"	70"
Capacities (qts.)						
Fuel Tank	3.38	4.25	4.25	4.25	4.50	4.25
Transmission	1.90	2.20	1.90	2.20	2.20	2.20
Crankcase	.65	.80	.65/1.26	1.31	1.85	.80
Running time @ 3000 rpm	2½ Hrs.	2½ Hrs.	2½ Hrs.	2½ Hrs.	2½ Hrs.	2½ Hrs.

NOTE: * Has "Reverse" control to change direction of travel.
 † May be adapted by mode of mounting wheels, or with optional accessories.
 ‡ Power unit with standard wheels and tires.

MODEL 605

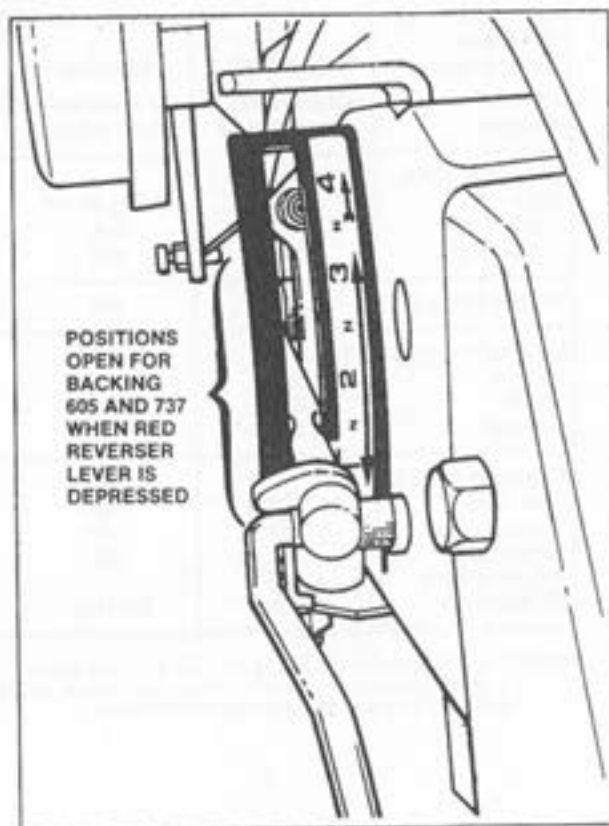
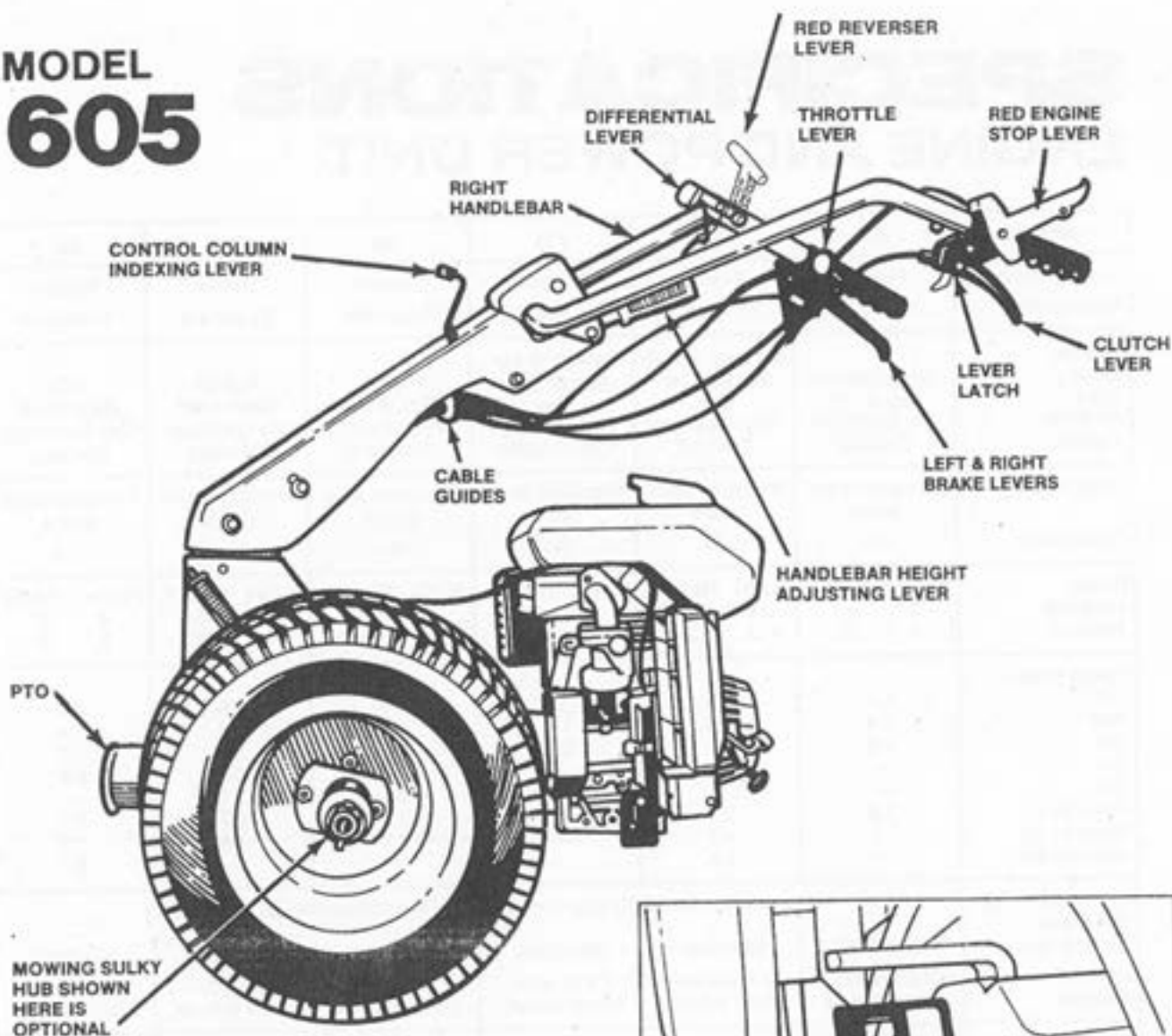

This "pusher" model, designed and geared to drive mowers and other front-mounted attachments, may be converted into a tractor by swinging the control handles around as illustrated on page 30.

Of the very latest design, the 605, like the 737 tractor, has both high speed and PTO/reverse safety lockout devices that function when needed, and require no disassembly or deactivation. A differential lever on the right handlebar has two-wheel drive and differential drive settings. In differential drive, applying just one wheel brake aids in turning to that side.

Whether in the front-drive or rear-drive mode, the unit will drive forward when placed in any gear on the gear selector. The 605 has the same red reverser lever on the right handlebar as does model 737. With the reverser lever pulled and left against the handlebar, and gear position #1, #2 or #3 selected, the unit will back up. Too fast to use when backing the unit, gear position #4 is blocked by the high speed lockout.

MODEL 737

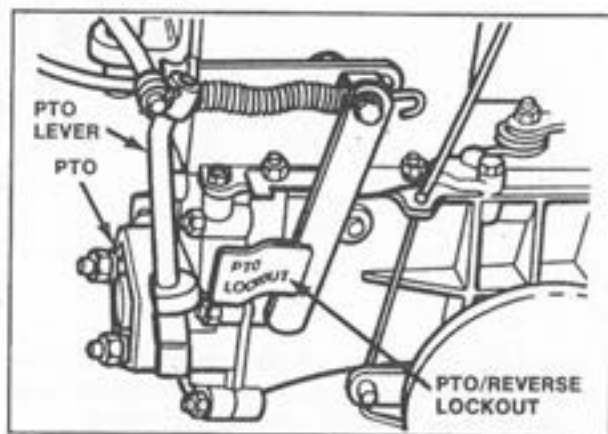
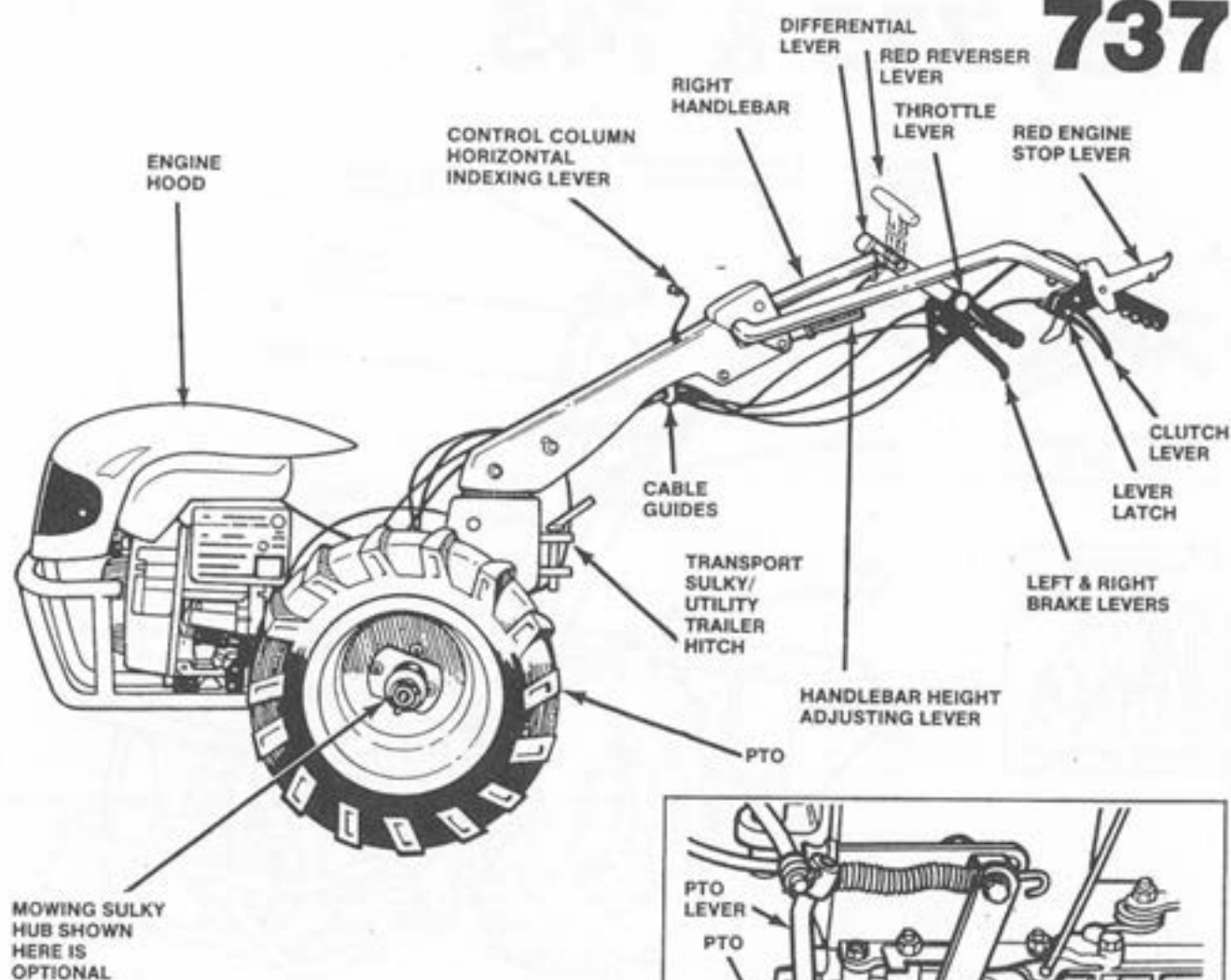

This tractor model was introduced in 1990 (along with its sibling, "pusher" model 605). Designed for rear tine tiller attachments, the 737 will appeal to those who wish to use both rear and front-mount attachments. In the rear-mount mode, the 737 has four gear speed selections available for forward travel. In the front-mount mode, three of these speed selections are available, with gear #4 blocked by the high speed lockout.

In either front-mount or rear-mount mode, backing up is done by pulling the **red reverser lever** on the right handlebar and selecting gears #1, #2 or #3. A **high speed lockout** blocks Gear #4. For protection when backing up a tiller, the 737 has a **PTO/reverse lockout** to block power to the tiller. The lockout affects neither **reverse** nor **forward** with the 737 in the front-mount mode.

Model 737 has combination differential drive and left and right wheel brakes. A differential lever on the right handlebar supplies a choice of differential or two-wheel drive. In differential drive, depressing just one brake lever will cause the unit to turn neatly to that side.

MODELS 715, 725 & 745

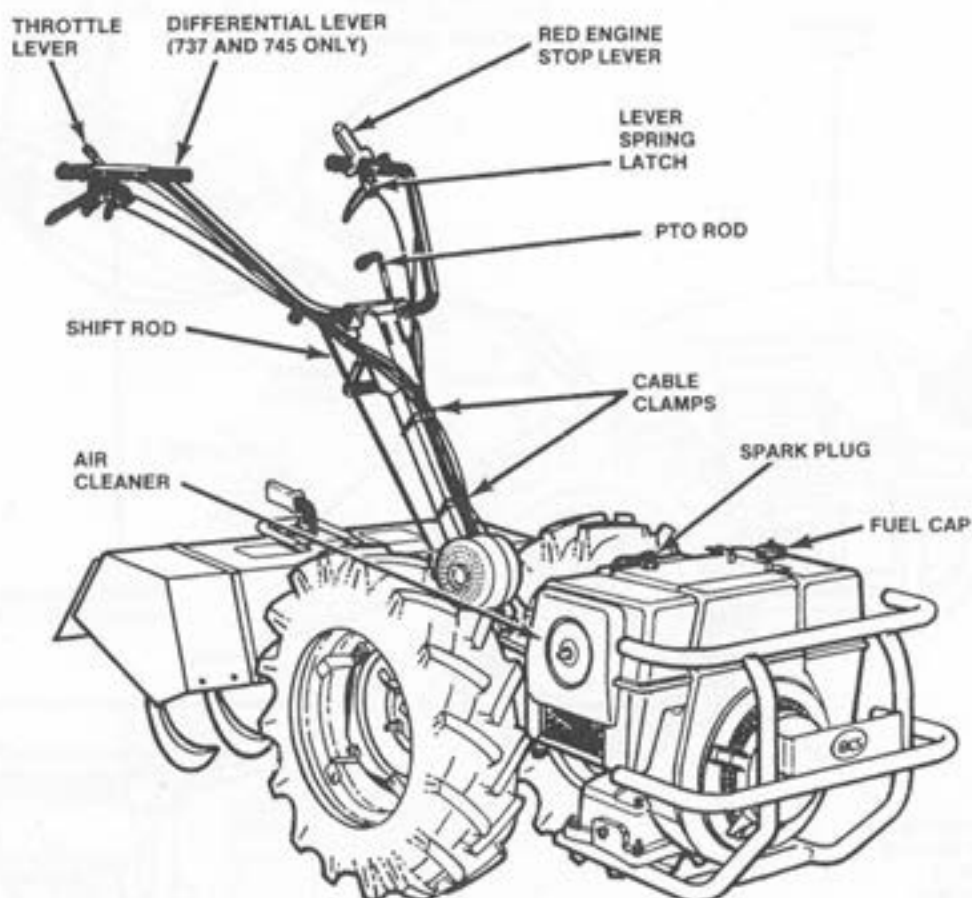
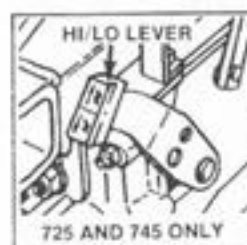

These three models are similar in many respects but different in certain details of construction and size. Model 715 is the smallest and 745 the largest.

Model 715 has three gears **forward** and one **reverse**.

Models 725 and 745 have five gears **forward** and two **reverse**, with the selection of speeds aided by a **HI/LO** gear reducer lever device. The 745 has both differential drive and two-wheel brakes.

On each of these models, a **PTO/reverse lockout** device prevents shifting into **reverse** with the **PTO** engaged. But, the lockout disengages automatically during operation in the front-mount mode where the unit drives forward in **reverse** gear. In the front-mount (converted) mode, all but the lowest **forward** speeds on the gear selector are blocked by the **high speed lockout**.

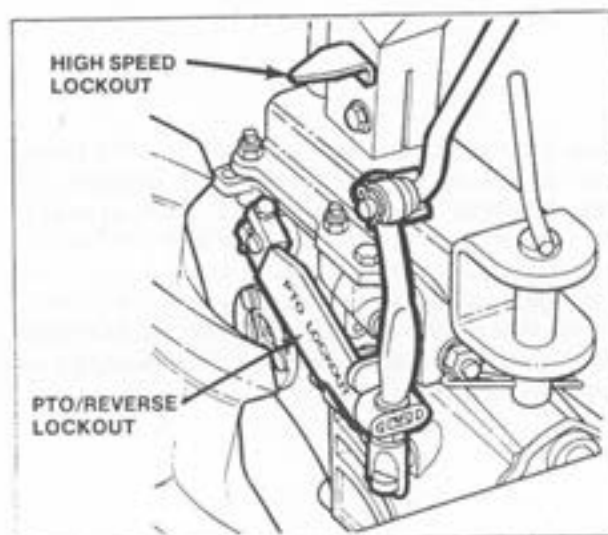

MODEL 602

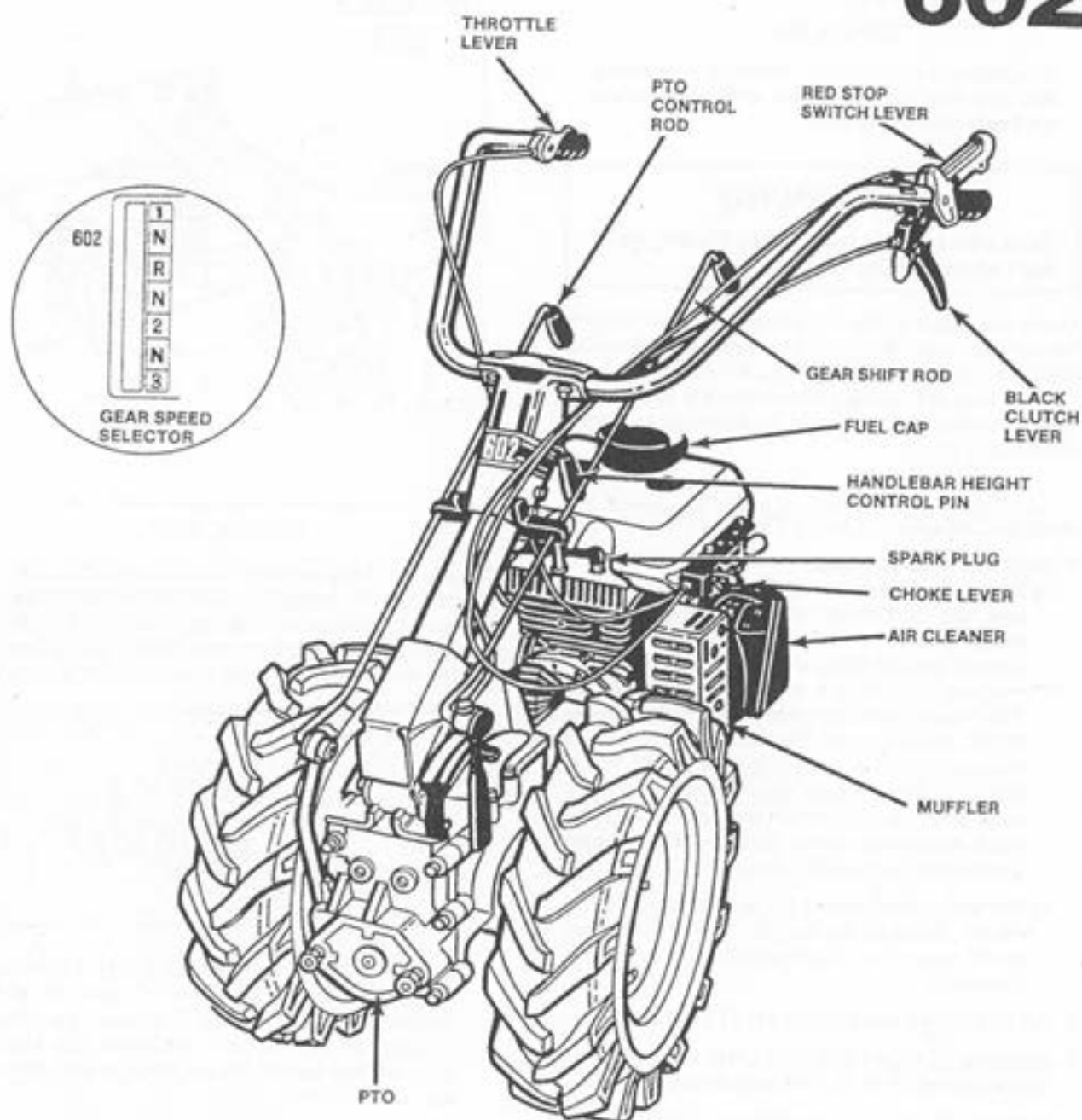

The 602 is the only unit in the current line of BCS America models designed exclusively for front-mounted attachments. Many persons select the model 602 for use with a Cutter Bar Mower or Single-blade Rotary Mower because of its size and balance. It is not convertible for rear-mounted tillers, but can supply the power to operate the Chipper/Shredder.

Model 602 has three gears forward and one reverse gear. Optional wheel spacers are available and are recommended for increased stability over rugged or steep terrain.

UNPACKING

IMPORTANT

Use extreme care to avoid crimping or severely bending the control cables while unpacking and assembling the unit.



WARNING

Take care to avoid being cut by the staples or nails when opening the carton.

Open the top and lay out the sides of the carton. Remove the parts and tools to be used in assembling the unit. The fasteners required for assembly have been placed at locations where they are to be used. These locations are shown in the drawings on pages 20 through 22.

ASSEMBLING THE UNIT

1. INSTALL THE WHEELS:

a) Except for one or two special sizes, most wheel and tire combinations can be mounted for either a wide or narrow track. For all applications except tilling and plowing, the recommended mounting is wide track for stability. The "Vees" of tractor tread tires should point in the direction of forward rotation. On convertible models, which can be used with both front-mount and rear-mount attachments, mount the wheels for the attachment that will be used the most. It is not necessary to remount the wheels when changing attachments.

b) For wide track, mount the wheels with the tire valves towards the outside. For a narrower track, mount the wheels with the valves toward the inside.

2. ADJUST TIRE PRESSURE TO 15 POUNDS.

3. ASSEMBLE CONTROL COLUMN TO COLUMN SUPPORT ABOVE THE TRANSMISSION.

MODEL 602: Remove the fasteners shown in exploded style in the model 602 drawing. Position the control column carefully on the support bracket, and install the M10 x 70mm bolts, spring washers and lock nuts previously removed. Secure the control rod supports to the control column. Pull the handlebar height control pin, raise the handlebar to desired height and pin it in that position.

MODEL 602

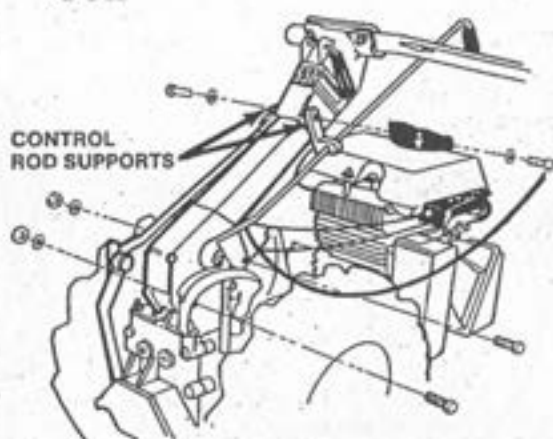

IMPORTANT

Refer to the drawing of the stop switch cable, showing the casing ferrule being inserted into a grooved retainer on the handlebar. Be sure to make this insertion on your model 602 so the stop switch can be used to start and stop the engine.



MODELS 715, 725: Remove the high speed lockout bracket along with the bolt and nut at the column support bracket. Position the control column on the support. Assemble the lockout bracket and column to the support with the bolt and nut.

MODEL 745: Remove the bolt, both cone washers and the nut from the bottom of the control column. Slide the column down onto the pivot post on the column support bracket. Install the bolt, cone washers and nut. Note the lever on the front of the column. Raising this lever lifts a locating pin out of a locking hole on the column support. The column then may be indexed to engage another hole in the support (or swung 180 degrees as required for use of front-mounted attachments).

MODEL 745

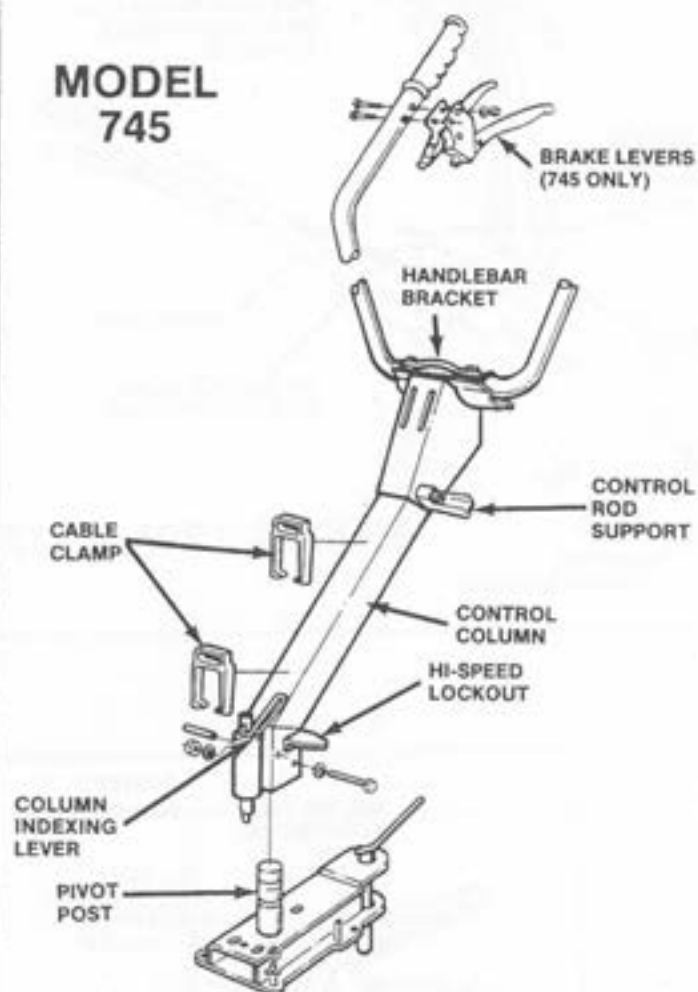

MODELS 715 & 725

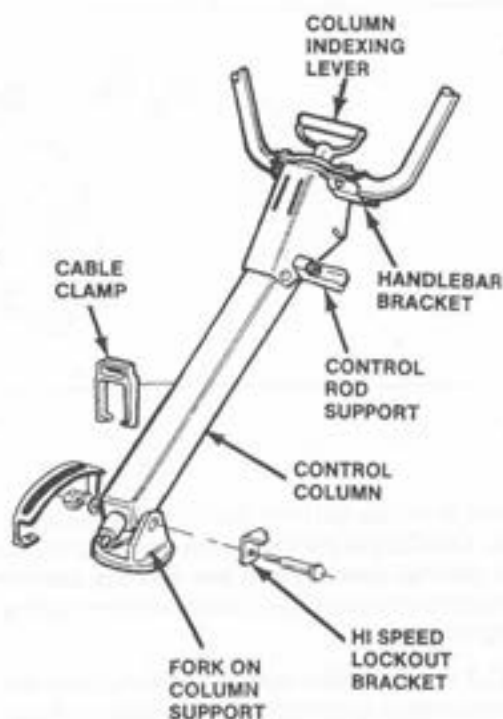

MODELS 605 and 737: These models come with the control column and handlebar preassembled, but mounted in a compact position on the unit. Remove the lower of the two bolts at the base of the column. Raise the column so it clears the filler cap on the fuel tank. Align holes in the column and column support, and reinstall the bolt. Secure with a lock washer and self-locking nut. Note the extra mounting holes in the column. It gives you a choice of column angles.

IMPORTANT

Models 605 and 737 both were packaged with the control column over the engine. Model 737 should have the column moved over the PTO end for operation of rear-mounted attachments. Follow instructions on page 31 to make the conversion.

4. ASSEMBLE HANDLEBAR SUPPORT BRACKET, AND CONTROL ROD SUPPORTS TO THE MACHINE:

MODEL 602: On the model 602, the control rod supports are on the control rods. Start from the right side to mount these at the bottom hole in the handlebar bracket. Tighten securely.

MODELS 715, 725, 745: Fit the control rods into the supports on each side of the control column and tighten the nuts.

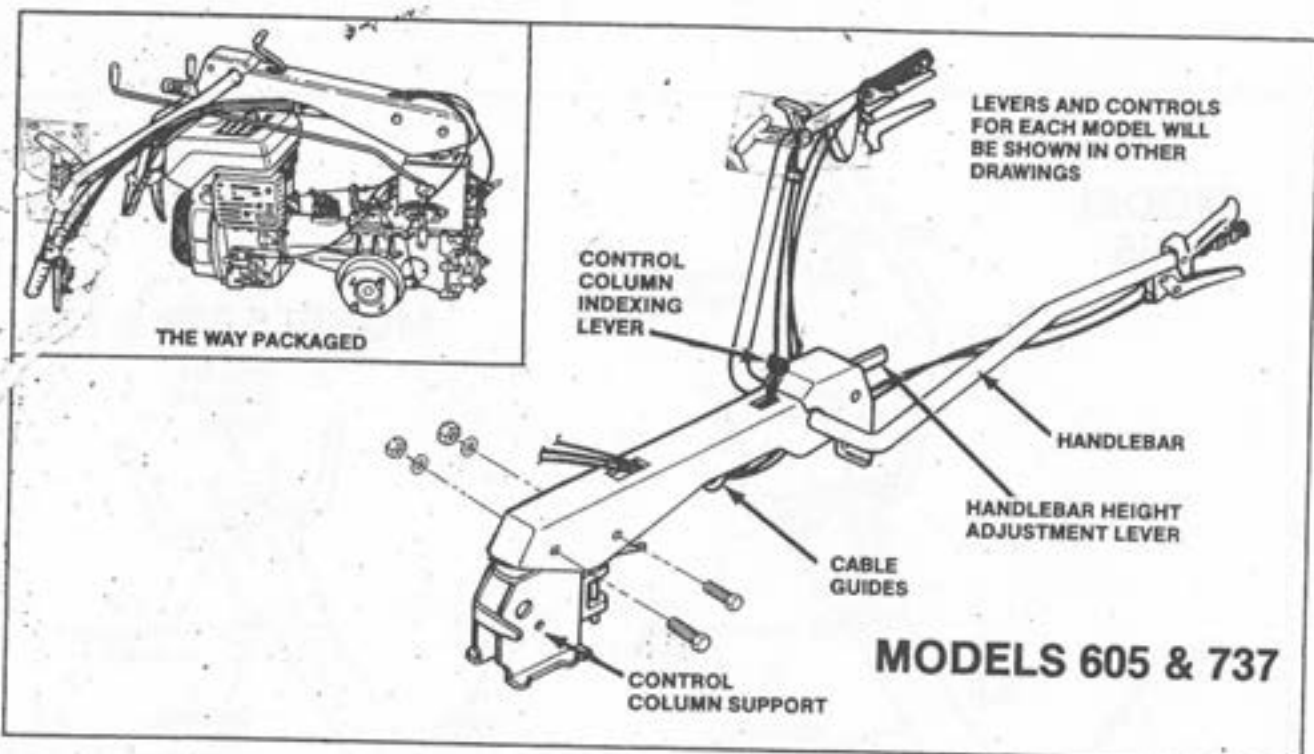

The control cables are threaded through two cable clamps. Carefully snap these clamps into position on the control column, and see that the control cables run neatly down the column without pulling or bunching.

MODELS 605 and 737: Fit the control rods into the supports on each side of the control column. Align the supports with the rods and tighten the nuts securely. Tuck the cables into the cable guides on the underside of the control column.

5. INSTALL BRAKE LEVERS (605, 737 and 745):

Models 605, 737 and 745 are factory equipped with two wheel brakes, controlled by brake levers on the right handle. The handlebar clamp nuts at top control column connection have been left loose, with the two wire clamps hanging loosely. Put the cables in the clips and position the clips to support the cables while tightening the clamp nuts.

An optional one-wheel brake kit (922.43799) is available for models 715, 725 and 602.

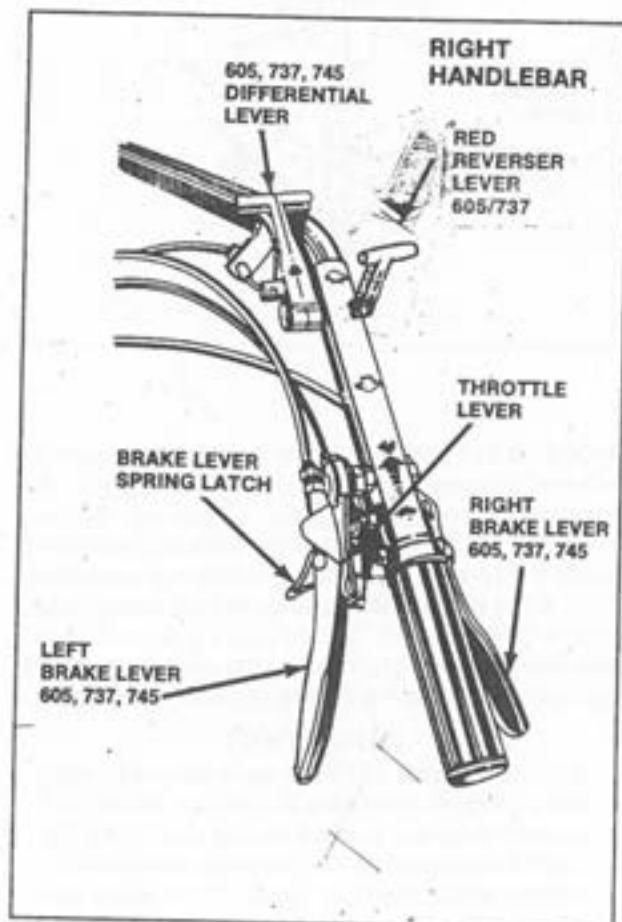

6. TRANSMISSION:

For shipping purposes, the transmission (gear case) filler hole is sealed with a plastic plug, and the dipstick is in the owner's kit. Remove the plug. Before installing the dipstick, it is important to oil the O-ring with a light engine oil. It also is important to install the dipstick with its flat side towards the center of the transmission. If installed flat-side-out, it will not be clear of the rotating gears. (See drawing.) Check the level of gear oil at this time. (See "Gearbox Lubrication" on page 24.)

7. ENGINE PRESERVICE:

BCS A220 and ALN330 ENGINES: Remove and discard the thimble-shaped, clear plastic cover from the oil breather tube located to the left of the carburetor. Remove the crankcase oil filler plug (or dipstick) and check that the oil is at proper level. (See "Engine Crankcase Lubrication" on page 24.)

KOHLER ENGINES: Check the oil fill cap/dipstick at topside of engine. If oil level is below full mark, see "Engine Crankcase Lubrication" on page 24. No other preservice is required. For Kohler engine operating and service instructions, see Kohler Engine operator's manual TP-2200-A.

LOMBARDINI DIESEL ENGINES: Refer to the Lombardini Engine instruction manual for all pre-service, operation and service instructions.

ELECTRIC SYSTEM BATTERY: The battery is a 12 volt 18AH, 33AH or 55AH. Push the unit to an open ventilated spot. Wear safety goggles and gloves when filling the cells with the electrolyte solution. Follow instructions supplied with the battery for filling with electrolyte, maintaining fluid level in the cells, and charging and recharging.

DANGER

The battery electrolyte is a strong acid. The acid or the fumes from it can cause severe burns. The battery constantly emits hydrogen gas which can be exploded by flame or sparks. Avoid contact with the battery acid. Always fill the battery in a well ventilated place, and do not bring flame or sparks of any kind near the battery. If acid contacts your body, flood the area immediately with soap and water.

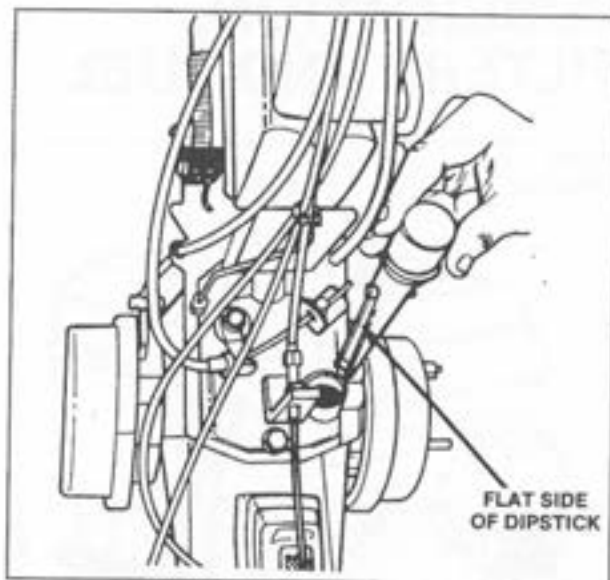

8. HOOD ASSEMBLY (700 series units only):

- Two rubber bushings are preinstalled in the engine mounting bracket and two more are packaged "loose." Install the loose bushings in the hood mounting bracket (see drawing).
- Align the hood and engine brackets and slide the long hinge pin through from one side to the other. Secure with a washer and cotter pin.
- With the clamp provided, attach the tether line on models 715, 725 and 745 from the hood to the hood support bracket on the engine.

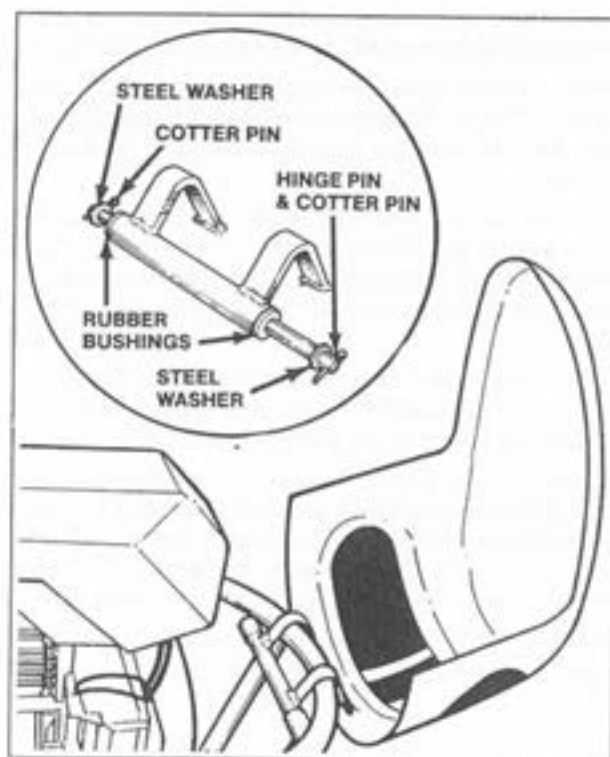

LUBRICATION, FILTERS AND FUEL

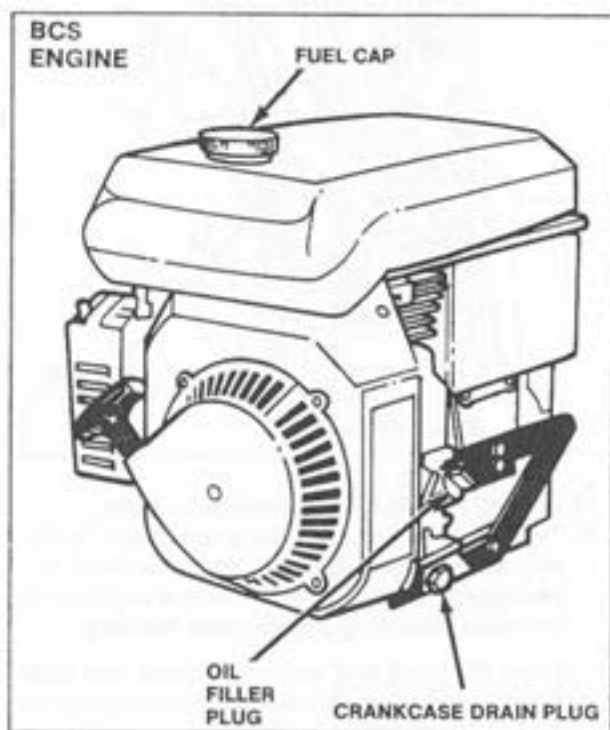

ENGINE CRANKCASE LUBRICATION

The oils selected for use should be high quality, high-detergent products of API service classification "SF."

The oil usually recommended for warm weather use is a straight SAE 30 weight. A multi-viscosity type oil such as SAE 10W-40 can also be used in warm weather.

When the air temperature falls below 32 degrees F (0°C) switch to 10W-40 or 10W-30 weight oil. For extremely cold (sub-zero Celsius) temperatures, it may be necessary to use SAE 5W-30 or 5W-20 weight oils.

Always check the oil level every day of use. Change the oil after the first five hours of engine operation, and at least once a season thereafter.

Put the unit on a level surface when checking oil level. If the engine has a dipstick, maintain the oil level between the high and low marks on the stick. If no dipstick, keep the oil level no lower than half an inch (12.7 mm) below the top thread of the filler hole.

When changing oil, always run the engine to get the oil warm. Then shut down, remove the drain plug,

NOTE

Engine manufacturers recommend the types and weights of oil for seasonal use in their engine. Always consult the engine instruction manual for their recommendations.

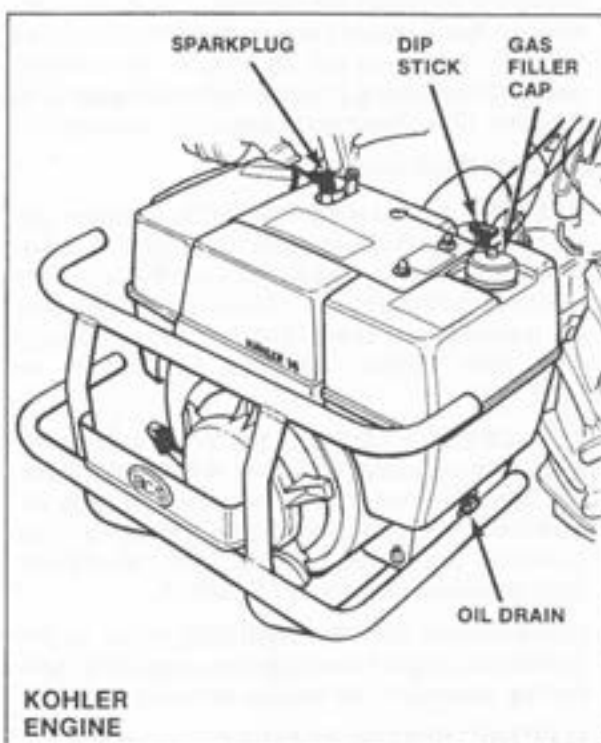

and drain the dirty oil into a container for proper disposal. Do not pollute the environment with waste oil.

GEARBOX LUBRICATION

The gearbox requires maintenance of the oil level with SAE 80/90 or SAE 90 EP (extreme pressure) gear oil. The gearbox filler cap (see drawing, page 23) has a dipstick with marker rings denoting full and low levels.

NOTE

When checked on a brand new machine, the oil level will be at the full mark on the dipstick. When it drops near the low mark add oil, but do not fill above the full mark. Do not operate if level is not up to the low mark.

1. Twist and pull up the filler cap to check the dipstick. Checking every 50 operating hours is recommended.
2. Put the dipstick back into the filler hole, and twist the stick around so the flat side is toward the center of the transmission gear box.

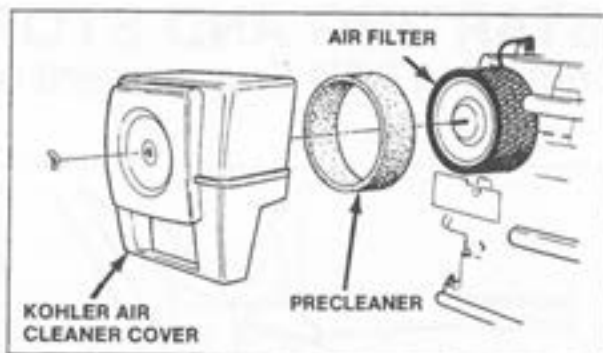
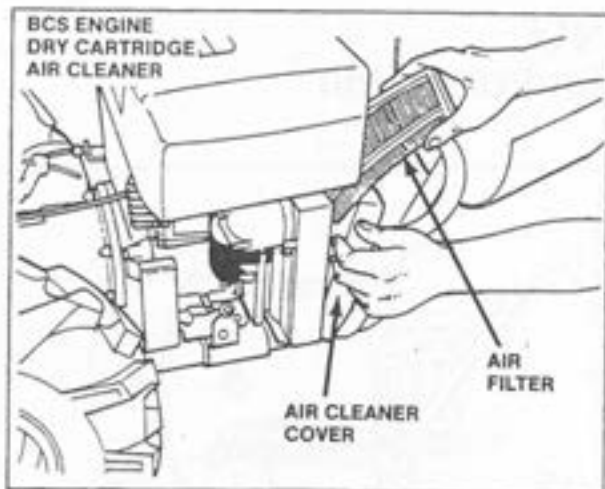

ENGINE AIR CLEANER

The dry element filters used on BCS and Kohler engines are shown in different drawings. Optional commercial type precleaner elements are available to fit these air cleaners. Precleaners are recommended particularly when using a Power Sweeper, Dozer Blade or Tiller in dry, dusty conditions.

Open the air cleaner and check the air filter at regular intervals. Under very dusty conditions, check often, and change filters when necessary. A clogged filter raises the engine temperature.

Dry element filters can be cleaned by tapping gently against a flat surface, but it is far better to replace a dirty filter than try to clean it. The precleaners, however, can be cleaned with soap and water or mineral spirits, but must be dried thoroughly, then oiled before use. Soak the cleaned and dried pre-cleaner in clean engine oil. Then squeeze out the oil before installing the precleaner.

GASOLINE ENGINE FUEL

The 4-cycle will run on either leaded or unleaded gasoline. Gasoline of 87 to 93 octane is recommended.



1. Remove the fuel cap, fill fuel tank, and re-install the cap securely.
2. Push the tractor at least 10 feet from fueling area and wipe off any spillage before starting the engine.
3. Open the fuel line valve at the tank outlet, so fuel can flow by gravity to the carburetor.

DANGER

Gasoline is explosive! Read page 2 of safety "Rules," before filling the fuel tank and starting the engine. Use approved type, properly labeled fuel containers. Do not smoke or bring fuel near any sparks or open flame. Do all fueling outdoors, never in a garage or shop connected to living quarters. Do not refuel when the engine is running or still hot.



NO FLAME!
NO SMOKING!



NO ELECTRICAL
SPARKS!

STARTING AND STOPPING

Including PTO Engagement and Control of Unit

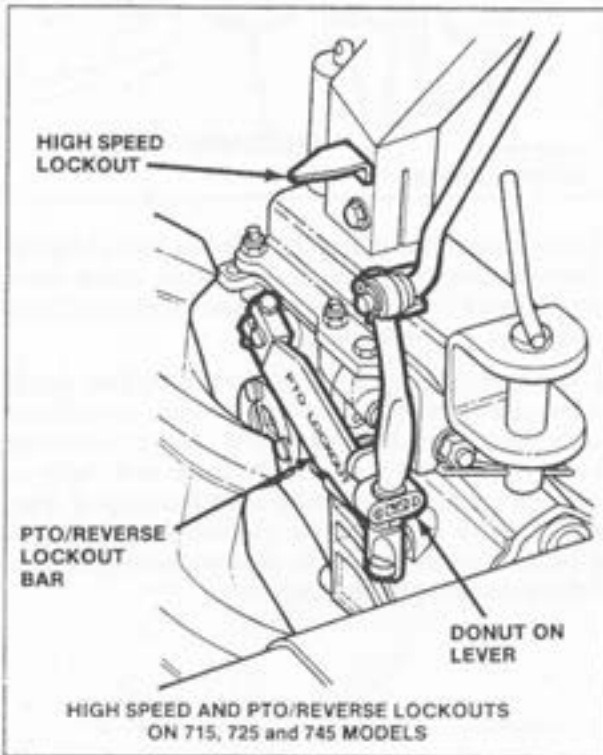

WARNING (715, 725 & 745)

When one of these convertible tractor models is converted for front-mounted attachments, REVERSE is used to go forward, and the lowest FORWARD gear position is used for backing the unit. The higher gear positions on the selector are blocked by the high speed lockout, because they are too fast for use in backing.

When the control handle is swung over the PTO for use of the rear-tine tiller, all positions on the gear selector are unblocked and ready for use. However, DO NOT USE THE HIGHEST FORWARD GEAR FOR TILLING. Use it only for transport to and from the work sight.

DO NOT REMOVE THE HIGH SPEED LOCKOUT OR RENDER IT INOPERABLE.

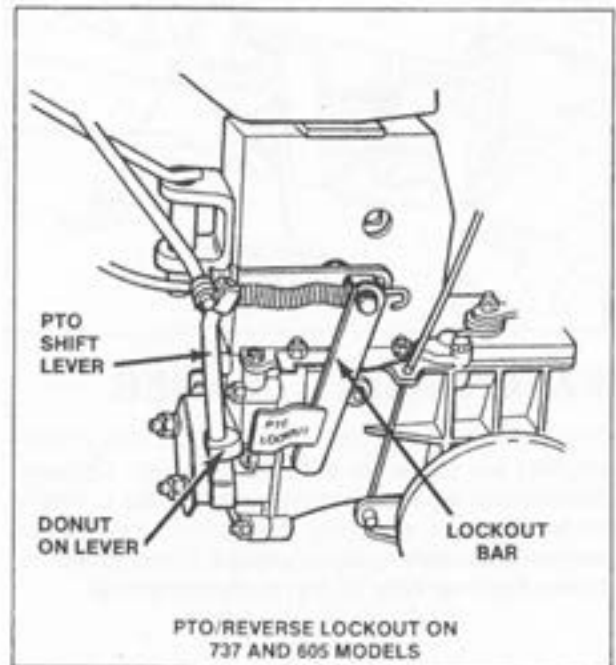

WARNING

Backing with the PTO engaged is dangerous. So all convertible units have a PTO/REVERSE LOCKOUT to prevent simultaneous engagement of PTO and REVERSE. On the 715, 725 and 745 you must be sure that the PTO lockout bar is aligned with the donut-shaped stop on the PTO lever when the unit is in the rear-mount mode. (See drawing.) DO NOT REMOVE OR MOVE THIS LOCKOUT BAR ASIDE FOR PTO ENGAGEMENT DURING BACKING OF THE TILLER.

WARNING

Be sure to shift into NEUTRAL (N) position on the gear selector, and disengage the PTO before starting the engine. If started in gear, the unit will move along. If started with the PTO engaged, a Tiller, or a Power Sweeper may run out of control. Inadvertent operation of any attachment can be dangerous.

SETTING CONTROLS FOR COLD STARTING

1. DISENGAGE THE PTO:

IMPORTANT

MODELS IN REAR-MOUNT MODE: Pull back on the PTO shift rod to disengage the PTO.

MODELS IN FRONT-MOUNT MODE: Push down the PTO shift rod to disengage the PTO.

2. **SHIFT INTO NEUTRAL.** On the gear speed selector, all positions marked "N" are neutral.
3. **OPEN THE THROTTLE.** Advance the throttle lever on the right handlebar to between half and full throttle position.
4. **OPEN THE FUEL VALVE.** If valve has a handle, open position is handle in line with the fuel line. If valve has a round control knob, turn the knob counterclockwise (to the left).
5. **CLOSE THE CHOKE.** Closed choke position on the carburetor is the upward or lateral position of the choke lever. Downward is "open choke," the position used after engine is running and warm.
6. **LATCH BOTH CLUTCH AND STOP SWITCH LEVERS FOR ENGINE STARTING:** The clutch is the **black** lever and the stop switch is the **red** lever on the left handlebar. The **red** lever has to be held depressed during operation, or it will shut off the engine. For starting, squeeze both levers against the handlebar with one hand, and prop them in this position by setting the wire spring latch. (See drawing.)

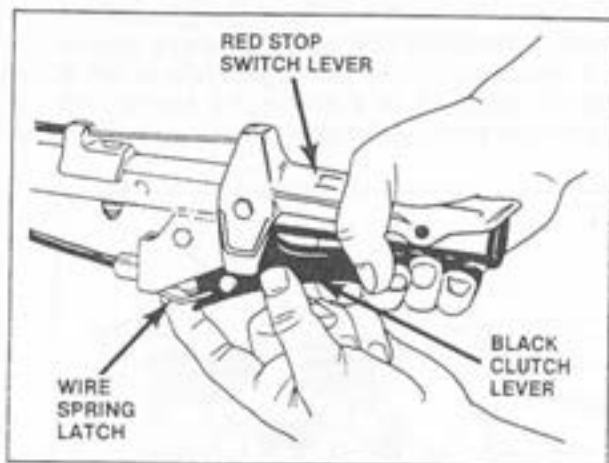

WARNING

The RED engine stop switch lever is designed to stop the engine in the event the operator loses control of the moving machine. It is necessary to latch the stop lever during starting, and to lock it in the run position when it is necessary for the operator to attend a stationary attachment such as the Chipper/Shredder. Pin holes are provided in the lever and handlebar for this purpose. For use of a moving attachment, **DO NOT LOCK, TAPE DOWN,** or otherwise defeat the purpose of the stop switch lever.

NOTE

Squeezing the clutch lever dislodges the wire spring latch, letting you take over control of the clutch. If you let go of the handlebar, the engine will be switched to a stop.

CRANKING TO START



RECOIL START ONLY: Read warning about starter rope. Grasp the starter grip with one hand only. Place your foot against the side of the tire tread to steady the machine. Pull the grip gently until the starter engages, THEN PULL RAPIDLY to crank the engine. Open the choke when the engine starts.

WARNING

NEVER WRAP THE STARTER ROPE AROUND YOUR HAND OR WRIST, OR USE TWO HANDS TO PULL THE STARTER GRIP. You want the grip to slip from your grasp if the engine kicks during cranking.

ELECTRIC START ONLY: Turn the ignition key to "START" to crank the engine. Key will return to the "RUN" position when you let go. When engine starts, open the choke.

ENGINE WARM-UP PERIOD: Let the engine warm up for a few moments without any load (in neutral (N) and PTO disengaged) to give the oil time to reach the parts of the engine in need of lubrication.

RESTARTING WARM ENGINE: When the engine has run and is still warm, it requires no choking to start. In fact, cranking a warm engine at closed choke may flood it.

STOPPING

Any time you let go of the left handlebar, the red stop lever on top will activate the ignition stop switch to stop the engine. On an electric start, turn off the switch to prevent current drain when the unit is not in use. In case the stop switch becomes open (disconnected) you can make an emergency stop on the engine either by closing the carburetor choke or by doing the following, according to engine model:

BCS A220 engine — push choke lever on engine from "0" to position "2" (full choke).

BCS ALN 330 engine — Push and hold in the red stop button (see drawing) until engine stops.

Kohler engine — Push choke lever on engine up all the way (full choke position).

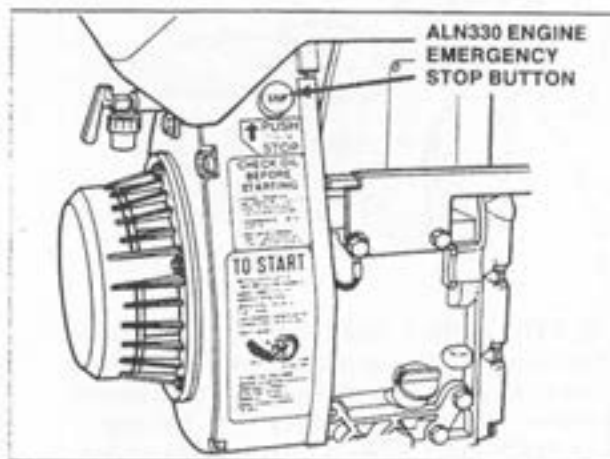

DIFFERENTIAL AND TWO-WHEEL DRIVE

A feature of models 745, 737 and 605, the differential drive directs the driving to one wheel, allowing the other to free-wheel. Differential drive facilitates making tight turns with the unit. When two-wheel

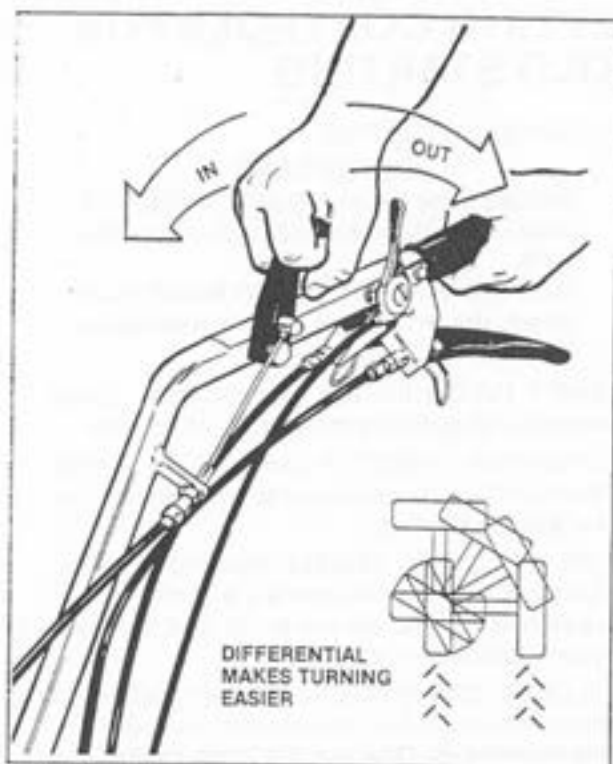

drive is needed for traction, lock in the differential lever on the right handlebar. When placed in differential drive, models 605 and 737 can be turned by squeezing the left or right brake lever.

WHEEL BRAKES

Models 605, 737 and 745 have two-wheel brakes, with brake levers on the right handlebar. The same type spring latch as the one for the clutch lever and stop switch is used to set the brake levers for parking. However, the machine may also be placed in gear to keep it from rolling when the engine is shut off. A one-wheel brake kit is available for models not equipped with two-wheel brakes.

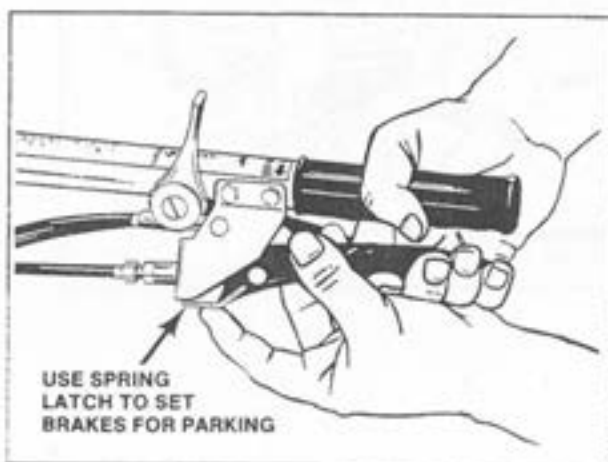

IMPORTANT

Directions such as right and left are always called out as you would see them when operating with the unit in the mode for which it was designed. However, when the handlebars of a convertible unit are swung 180 degrees from designated position, the right lever on the right handlebar will still brake the right wheel. But the right wheel will be on the left side.

SHUT-DOWN

(See instructions on page 8.)

TAKING CONTROL OF THE MACHINE

1. When the engine is running, grasp the left handlebar. Hold the **stop switch** depressed and squeeze the **clutch lever** to dislodge the spring latch. Now both clutch and stop switch levers will be under your control.
2. Do not let up the **stop switch** lever or it will stop the engine. When ready for action, shift into the desired gear and release the clutch lever. Instructions for operation of unconverted units are given immediately below, and those for converted units are on page 31.

NOTE

Transmission to the axle and wheels is independent of transmission through the PTO to an attachment. The advantage of this SOA design is that the most efficient operating rpm of the attachment can be selected by the throttle setting, and the desired machine movement chosen independently through a combination of throttle setting and gear selection.

GEAR AND PTO ENGAGEMENT

(For Converted units, skip to page 31)

1. On models 725 and 745, set the HI/LO gear range lever in the low speed (yellow) range while you are learning to operate.
2. Start the engine and take over control of the unit. Keep the throttle at moderate speed setting.
3. Hold the clutch lever (left handlebar) depressed while shifting, and engaging the PTO lever, and until you are ready to drive.
4. Shift into the lowest forward speed position on the gear speed selector. If the gears will not engage, release (slip) the clutch just a bit until the gears mesh.
5. Smoothly release the clutch lever and the machine will move forward. If you wish to stop momentarily without killing the engine or shifting into neutral, depress the clutch lever fully.
6. FOR ALL MODELS EXCEPT 605 and 737: Before engaging the PTO, you can shift out of low gear into **reverse**, or any neutral (N) or **forward** gear on the selector. When the PTO is engaged, the **PTO/reverse gear lockout** will block your shifting into **reverse** or going past it to a high gear slot. When you are in **reverse**, the PTO will be blocked. When you are in low gear and wish to go past **reverse** to a high gear, declutch and disengage the PTO. (Do the same when changing the HI/LO gear range lever setting on models 725 or 745.)
7. USING RED REVERSER FOR BACKING 605 or 737: Disengage the clutch. On model 737 you also must disengage the PTO. Positions 1, 2 and 3 on the gear selector will be available for backing, and 4 will be locked out. Select speed, and depress the **red reverser** lever on right handlebar before engaging the clutch.
8. HI/LO GEAR RANGE: This device on models 725 and 745 provides a selection of five speeds **forward** and two **reverse**. The color code of the HI/LO lever and corresponding position on the gear selector is **red** for faster, and **yellow** for slower speeds.

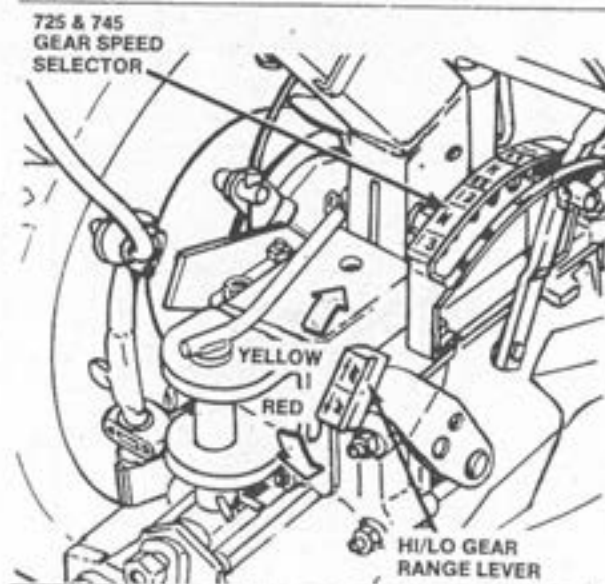

MAKING A CONVERSION FRONT-TO-REAR, OR REAR-TO-FRONT

NOTE

Put on the new attachment (or leave the other in place) to keep unit from rotating during positioning of the control column.

MODEL 605
PUSHER TO
TRACTOR

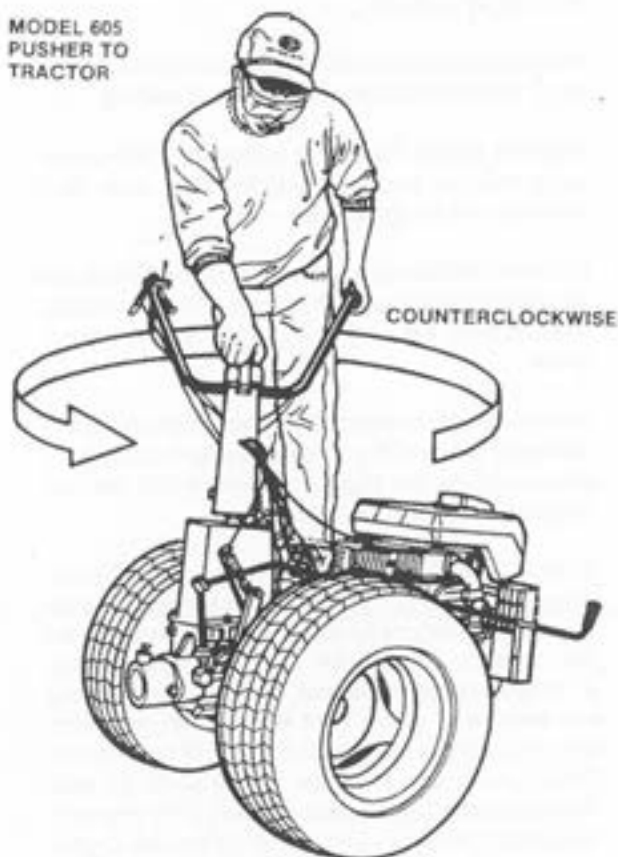

ALL 700 SERIES -
TRACTOR TO PUSHER



1. Shift into the lowest **forward** gear position. This will provide clearance for turning the handlebars to the other end of the unit.
2. Detach the PTO and gear selector shift rods from their supports and let them hang down.
3. Locate the control column indexing rod or lever. (According to model. See drawings.) Use it to free the column from the support in preparation to swing it around.

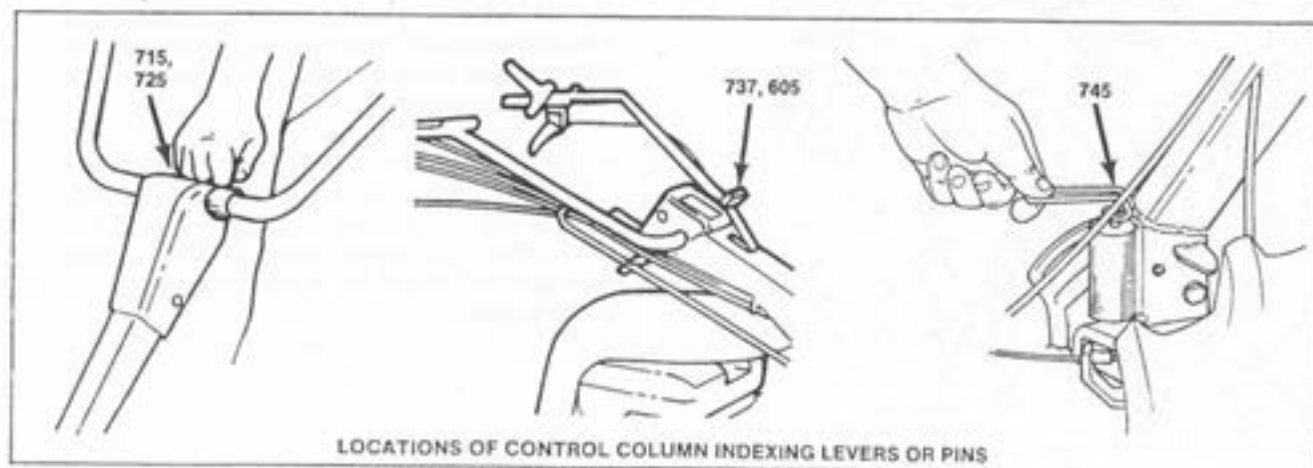

- Be careful not to stress or sharply bend the control cables while indexing the control column. **Turn column 180 degrees as follows:**

a) Models 715, 725, 745 and 737: Convert from tractor to pusher by pulling rod or lever and turning the control column 180 degrees counterclockwise. (To go back to tractor mode, turn clockwise.)

b) Model 605: Convert from pusher to tractor by pulling the lever at top front of control column and turning column 180 degrees counterclockwise. (To go back to pusher mode, turn clockwise.)

- Put the shift rods back in their brackets on the control column. Check the position of the control cables and see that they are neither bunched up nor pulled taut.

OPERATING IN CONVERTED MODE

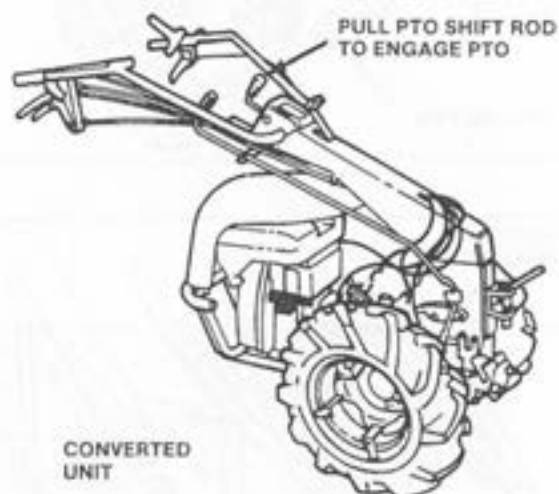

- ALL MODELS:** Push the PTO shift rod forward to disengage the PTO. Note that, in the converted mode, you push the PTO rod for disengagement and pull it back for engagement.
- Shift into desired gear according to model:
 - Models 715, 725, 745: In the mode for front-drive, the **high speed lockout** blocks shifting into all but three positions on the gear selector. The decal which reads correctly (as seen from behind the engine) labels them "F" (forward), "N" (neutral) and "R" (reverse). The decal denoting the gear selections for rear-mount applications appears upside-down. The HI/LO gear range lever may be used on models 725

and 745 to obtain high and low speeds in both "F" and "R" selections.

b) Models 737 and 605: In the converted mode, three of the four gear positions on the gear selector can be used for travel in either **forward or reverse** direction. The fourth gear is blocked because it is too fast to use for backing the unit. Select desired gear and engage clutch to move forward. To back up, disengage clutch, engage the **red reverser** lever on the right handlebar and engage clutch.

- Engage the PTO and the clutch to put the unit to work.

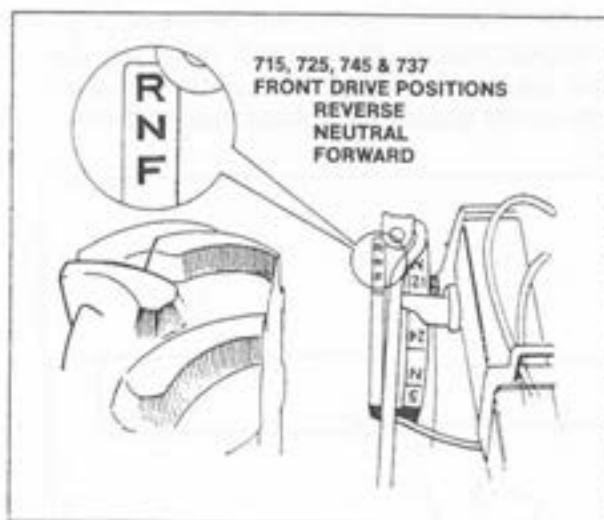

MAINTENANCE PROGRAM

1. Refer to the maintenance instructions and illustrations in the "Use and Maintenance" manual furnished for your model engine. Change oil, filters, etc., and clean the cylinder fins and crankcase breather as instructed in the engine manual.
2. **DAILY CLEAN-UP:** When the machine is very dirty you may hose down everything except the engine immediately after use. But to avoid cracking the engine, you must let it cool before hosing it down. You may, however, idle the engine until it is warm enough to evaporate the wash water from around the spark plug.
3. **AFTER FIRST 10 OPERATING HOURS** (and afterward as recommended):
 - a) Tighten nuts and bolts.
 - b) Check tire pressure.
 - c) Originally, the position of «A» lever is normal. As clutch wears out the same lever could have a wider opening, being so uneasy to use, this means that it is necessary to adjust the cable, setting lever «A» on its original position acting on adjustment device «B» and on counter-nut «C».
 - d) Check the gear oil level of each attachment. Recheck rotary mowers every 50 hours and the other attachments every 100 hours.
4. **OCCASIONALLY AS NEEDED:** Clean any dirt and old grease from the PTO connections of all equipment and pack with clean bearing grease.

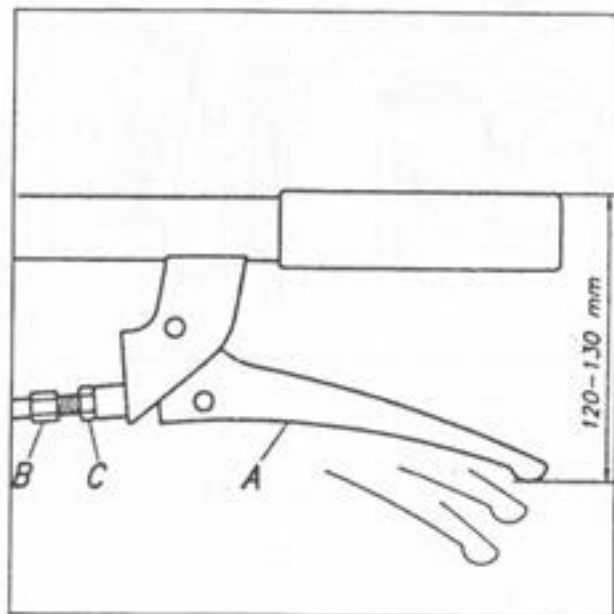

5. **SEASONALLY:**
 - a) Lubricate the control cables with a light oil.
 - b) Models with engine hood: Lubricate the hinge with a light oil. Do not use mineral oil.
 - c) Clean parts thoroughly and apply grease to the control column indexing rod or lever, column fork, column support or pivot post (according to model).

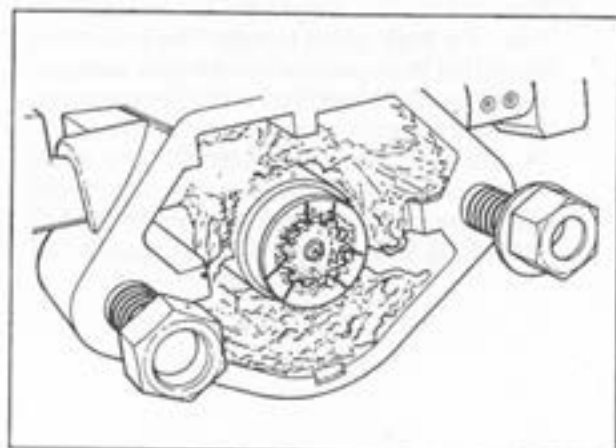
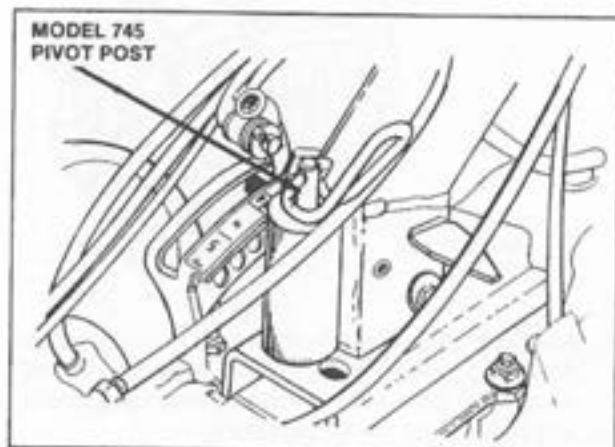
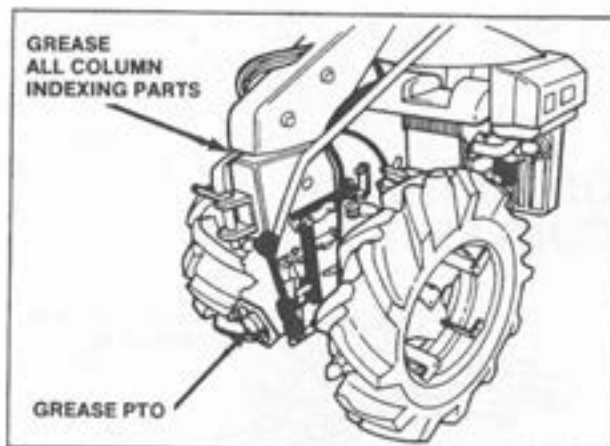

SECTION THREE

USE AND CARE OF ATTACHMENTS

LUBRICATION OF ATTACHMENTS

1. **TILLERS, ROTARY MOWERS, SNOW THROWERS AND POWER SWEEPERS:** Remove the pipe plug on top of the attachment gear housing. If the oil level is more than 2 inches (50mm) below the filler hole, fill to the top with SAE 80/90 or SAE 90EP (extreme pressure) gear oil. Maintain at the nearly full level.
2. **MOWER BARS:** These require no gear oil, but need frequent greasing with a lithium based (general purpose) grease pumped through two "zerk" type fittings on the housing.
3. **ALL ATTACHMENTS:** Remove dirty grease, and lubricate the PTO coupling of the attachment with bearing grease whenever greasing the unit PTO. For other points of lubrication, see the particular attachment.

COUPLING ATTACHMENT TO PTO

When the PTO flange of the attachment is coupled to the unit PTO flange and the PTO is engaged, the splined shaft slides out to engage the splined (grooved) shaft of the attachment. Then the shafts rotate as a single member until the PTO shift lever is used to retract the drive shaft.

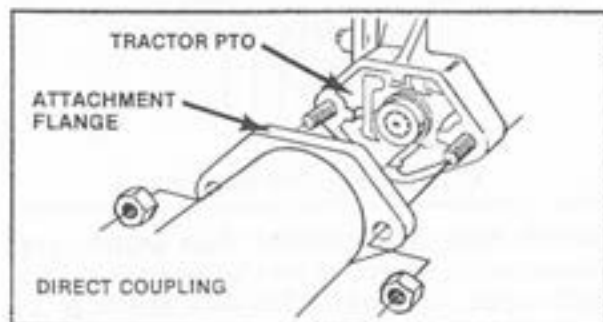

Although the attachment may be coupled directly to the unit PTO, there is a quick hitch that can shorten the time for coupling and uncoupling attachments. There are also PTO extensions in lengths of 3" and 6" which can be coupled between the PTO and attachment for better balance with certain attachment and engine combinations.

A. DIRECT COUPLING:

1. Remove the lock nuts and washers from the tractor PTO studs.
2. Align the tractor PTO with the connecting flange of the attachment. Always bring the tractor to the attachment. If necessary, use props to level the attachment.
3. Slide the PTO studs into the attachment flange and secure with the washers and lock nuts.

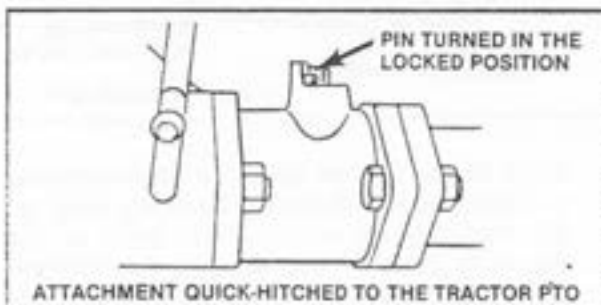
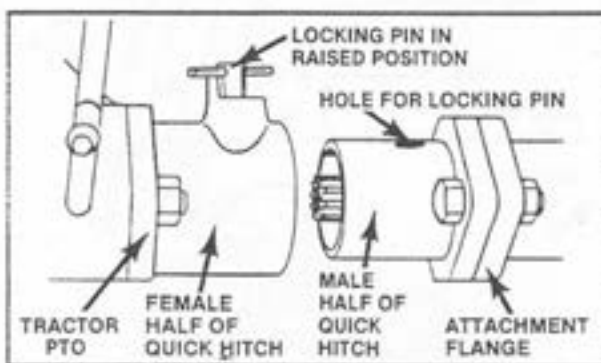

B. QUICK HITCH:

1. The hitch consists of two parts held together by a captive T-handled pin. Pull and turn pin sideways, to separate the parts.
2. Remove the two nuts from the tractor PTO studs and the two bolts and nuts from the quick hitch.
3. Attach the female part, pin-side-up, to the tractor PTO. Attach the male part, hole-side-up, to the attachment connecting flange. Install and tighten the four nuts.
4. Fit the attachment part into the PTO part. Twist the pin so it drops down into locking position, securing the two parts together.
5. To uncouple, pull the pin.

NOTE: Attachments designed for model 745 cannot be coupled to PTOs of other models.

USE AND CARE OF REAR-TINE TILLER ATTACHMENTS

PREPARING NEW TILLER

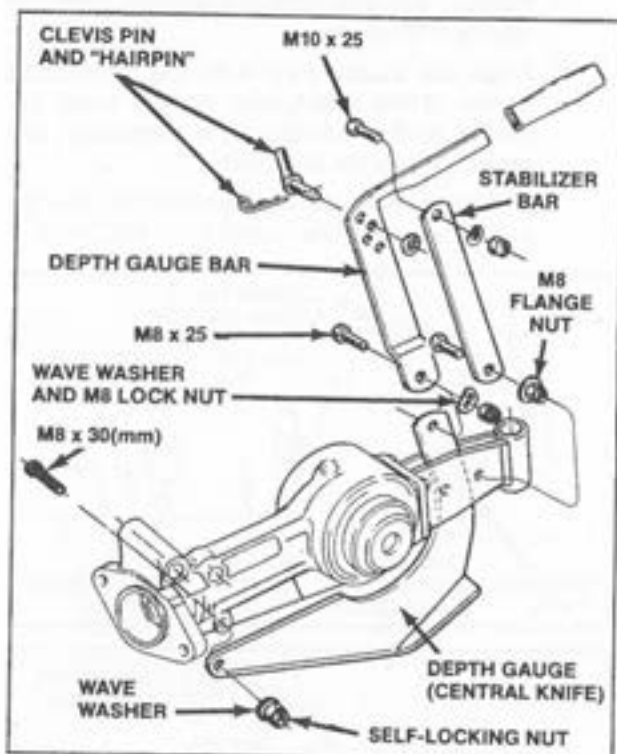

1. Open the carton and stand the tiller on end so you can see the underside. Fasteners required for the assembly are included. The bolts in the assembly drawing are labeled (M8 or M10) for the metric diameters, and length is given in millimeters. If a sulky or utility cart is to be hitched to the tractor, assemble the depth gauge bar in a position 180 degrees from that in the drawing.
2. Use the self-locking nut to fasten the depth gauge to the gear housing. Install the flange nut at the stabilizer bar bottom connection.
3. The depth gauge and stabilizer bar protrude through the top of the tiller housing. The bar is bolted to the brackets. The gauge is pinned with the clevis pin and "hairpin." Tighten all nuts.

WIDTH OF TILTH IMPORTANT

When changing sets of lines, it is important to keep the tines in place on one side for use as a model while changing tines on the other. Do not mount the tines backwards on the flange.

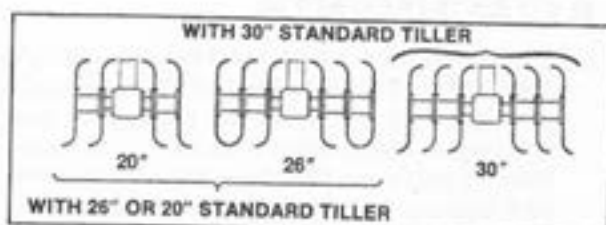

**SINGLE ROW ATTACHMENT FOR 715, 725, 737 (or
Converted 605):** Available sizes are 20", 26" and 30".

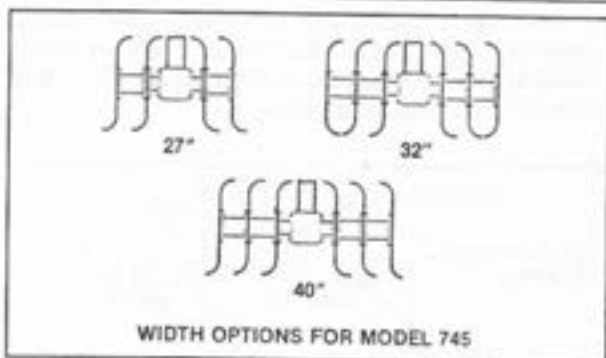
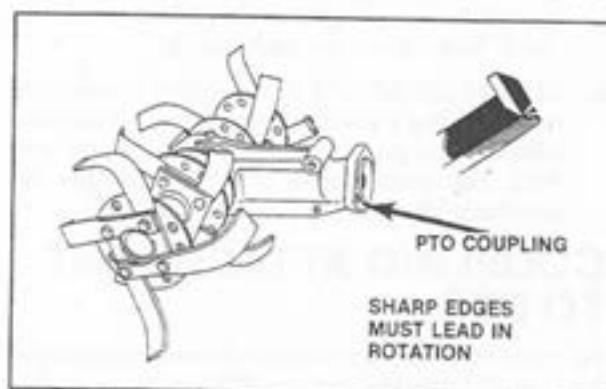

SINGLE ROW ATTACHMENT FOR MODEL 745:
This comes preassembled for a 32" tilling width. The width can be increased to 40" or decreased to 27" by adding or removing flanges of tines, and by changing the tines to bend inward or outward. (See drawing.)

TILLING DEPTH ADJUSTMENT

The procedure is the opposite of what many people first would believe. For the deepest soil penetration, you raise the depth controlling "knife" by pinning the bar in the bottom hole. (See drawing.)

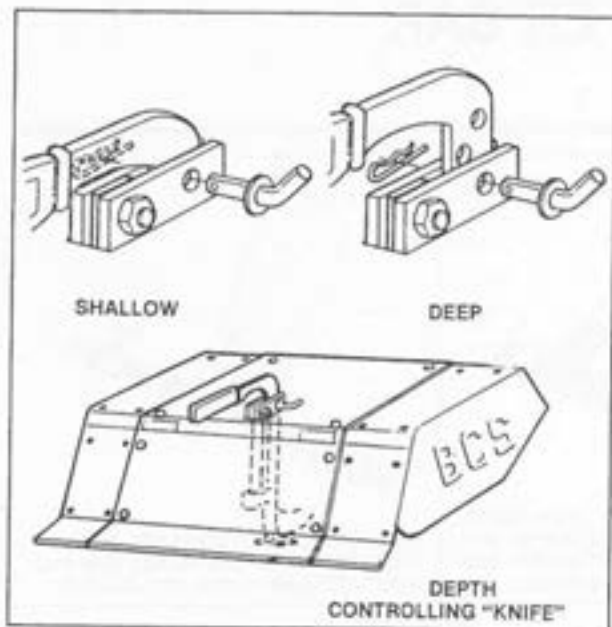

1. Remove the hairpin and the clevis pin from the bracket and bar.
2. Raise or lower the bar handle to align the holes in the bar and brackets. Pin the bar at desired setting, or as recommended in step 3.
3. In hard ground, as when tilling a patch of ground for the first time, pin the depth adjustment rod through the top hole for a shallow cut. After a pass or two to break up the hard top crust, stop the engine and pin the depth adjustment bar through the lower position hole. Pinning the bar through the bottom holes raises the depth-gauging "knife" for maximum tilling depth.



GARDENING SUGGESTIONS

1. Wide tines are good for all tilling and cultivation work, and the better choice for use in hard or rocky soils. Standard width tines give superior results and a finer texture in soft, grassy or sandy soils. When breaking new ground, or preparing hard, rocky soil, till at a minimum depth, at the lowest gear setting, and at a fast throttle setting. In soft soils, you can probably start right off tilling at maximum depth and finest tilth are achieved in the lowest gear speeds.
2. You can avoid trampling over and tamping the fresh-tilled rows by walking to one side of the tiller. Swing the handlebar to the side and adjust it to a comfortable height. After a bit of practice with the tiller, you can work out a pattern where your footprints will be erased with each new pass.

TRANSPORT SULKY FOR REAR-TINE TILLER

The Transport Sulky is exclusively for riding the machine to and from the working site. As warned in Section One, you must never operate the Tiller from a sulky or wagon of any type. A curved coupling is needed to attach the Transport Sulky to most models. However, model 715 requires installation of an optional hitch and pin assembly (No. 922.49997) for the curved coupling, or a vee drawbar.

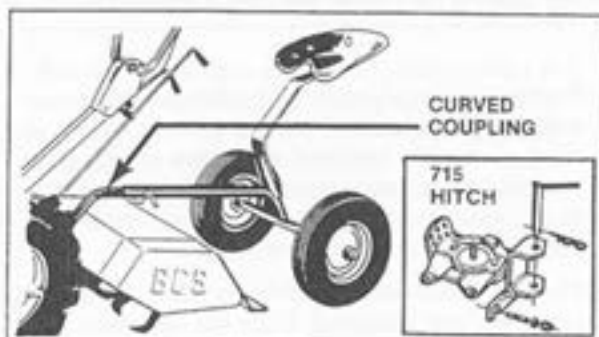

USE AND CARE OF CUTTER BAR MOWER ATTACHMENTS



GENERAL CUTTER BAR MOWER INFORMATION

1. 700 SERIES TRACTORS must be converted to the front-mount mode. See instructions on pages 30 and 31.
2. The SICKLE BAR and MULCHER BAR are the two original types of BCS mower bars. The COMBINATION BAR combines features and abilities of both. Although construction of the bars is very similar, there are differences to be encountered in adjustment and maintenance.
3. The soft (plastic or aluminum) blade coupling at the center of the bar is designed to break if an obstruction stops the blade from reciprocating. Keeping one or two spare couplings on hand is recommended.

RECOMMENDED OPERATION

WARNING

Never operate the mower bar from a mowing sulky.

1. It is unnecessary to run the engine at wide open throttle for satisfactory performance. Cutter bar mowers give excellent results when operated at medium throttle settings, and there is less wear and tear on the reciprocating parts. If necessary to increase ground speed, select a higher gear rather than advance the throttle.
2. The short teeth of the Mulching Bar can cut wet grass without clogging. Both the Mulching and

Combination Bars are designed for recutting (mulching) mown grass. For brushcutting, and also when operating in extremely rugged terrain, go slowly and deliberately with either type attachment.

3. The Sickle Bar is designed specifically for cutting grass. It cannot recut mown grass and is not suitable for cutting brush.

MOWER BAR MAINTENANCE

1. Wash down and re-oil the sliding parts after each use.
2. Every four operating hours pump a lithium base grease into the blade control mechanism through the two grease fittings on the central housing. (No gear oil is required for this attachment.)
3. The cutting teeth should be removed and sharpened with a grinder. For blade removal, remove the two bolts and the blade coupling. Then slide out the blade.

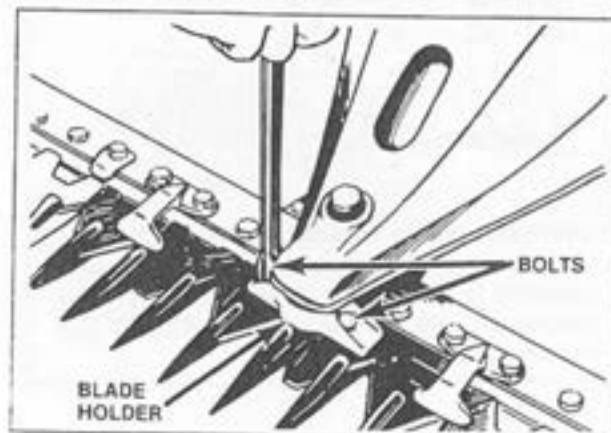

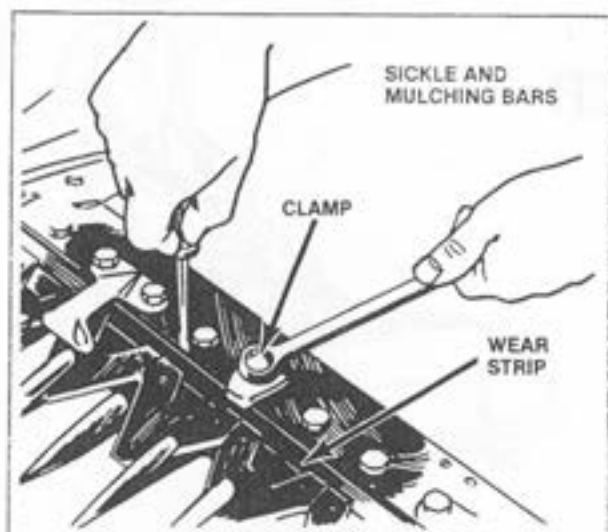

4. This step of adjustment is required only for the Sickle and Mulcher Bars and not for the Combination Bar: When play between the wear strip and blade becomes excessive, loosen the wear strip clamps and push the wear strip closer to the blade with a screwdriver tip. Tighten the clamp bolts securely.
5. The tension between the blade and the tooth comb is set by adjusting the blade holders (described below).

NOTE

The tension must be snug enough for clean cutting action, but should not freeze or bind the blade against the tooth comb.

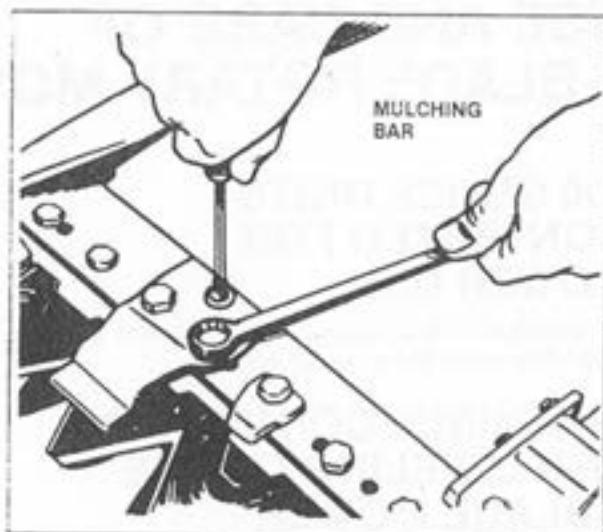

- b) **MULCHING BAR:** Loosen the blade holder bolts and increase the tension by turning the blade holder adjusting screw clockwise. Tighten the bolts before checking the tension. Repeat tensioning process, if required, until tension is correctly "snug."
- c) **COMBINATION BAR:** Loosen the blade holder bolts. Then loosen and hold the lock nut from turning, and use a wrench to turn the jackpost type adjusting screw against the blade holder. Check the tension after tightening the lock nut and the bolts. Repeat tensioning process, if required, until tension is properly snug. Rear play can be eliminated by pulling back the blade holder when tightening the nuts.

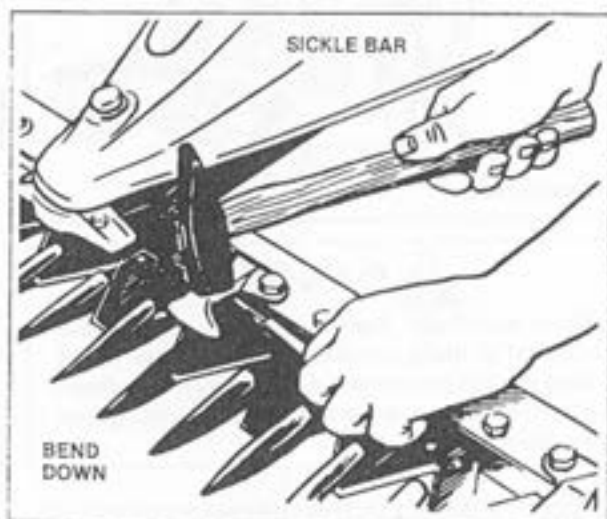

- a) **SICKLE BAR (with no adjusting screw):** Loosen the blade holder bolts. Support the assembly on a firm surface. Slide a screwdriver shank under the neck of the blade with light hammer strokes. Tighten the bolts and check the blade tension.

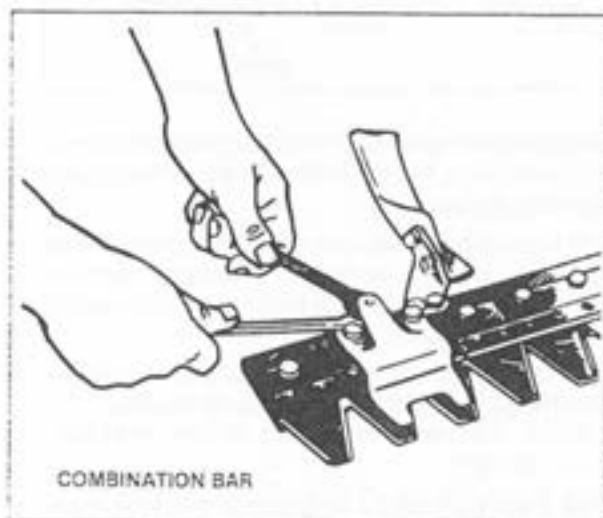

6. **REPLACEMENT PARTS:** See your dealer for parts. Replacement teeth, and also complete, riveted mower blade assemblies are available.

USE AND CARE OF 2-BLADE ROTARY MOWER

700 SERIES UNITS CONVERTED FOR MOWER USE

For conversion and operation of your unit in the front-drive mode see pages 31 and 32.

ASSEMBLY, CONNECTION AND LEVELING OF THE 2-BLADE MOWER

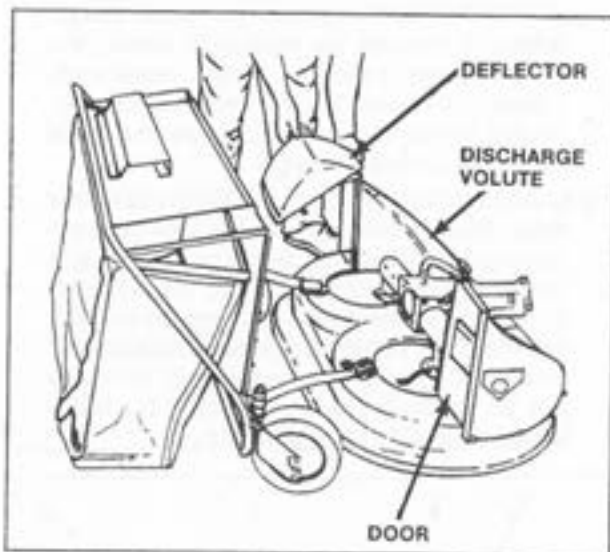

The attachment is packaged with the grass catcher in place on the deck, but the following must be done in preparation for use:

1. Lift the catcher at the rear and tilt it forward. Note that the catcher assembly is pinned at the front on both sides, and may be removed if not needed to catch the grass.
2. Remove the bolts, washers and nuts from the discharge volute bracket. Use them to attach the curved discharge deflector to the bracket. (See drawing.)
3. The discharge volute on the opposite side from the one in step 2 has a flat door hinged down the side. No assembly is needed.



DANGER

Open discharge from the volutes without the catcher in place can be very dangerous. Make sure door is closed and deflector is in the down position when mowing without the grass catcher.

4. POSITIONING OF THE DISCHARGE DEFLECTOR AND DOOR:
 - a) For mowing without the grass catcher, the discharge deflector **must** be in the down position, covering the opening so the clippings will not be thrown out. The door **must** be in closed position across the other opening for the same reason.



within $\frac{1}{2}$ " of the top of the housing. If low, fill with SAE 80/90 or SAE 90EP gear oil to the top of the filler hole. The oil level should be checked each 50 operating hours thereafter.

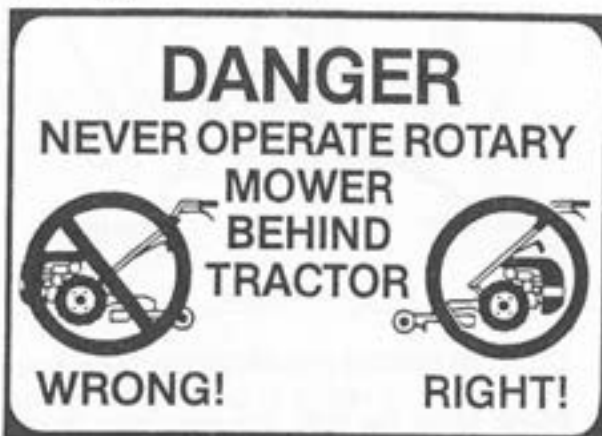

ROTARY MOWER OPERATION

- b) When putting the grass catcher into position on the deck, open up both volutes to discharge into the catcher compartment — swing open the door, and lift the curved deflector upward out of the way.
- Put the unit on a level surface. Remove the nuts from the PTO studs, and mount the mower to the PTO.
 - The mower deck should be level for even mowing height. The wheel mounting brackets have three holes. If leveling is required, remove the wheel retaining hairpins and remount the wheels in a higher or lower hole as required.

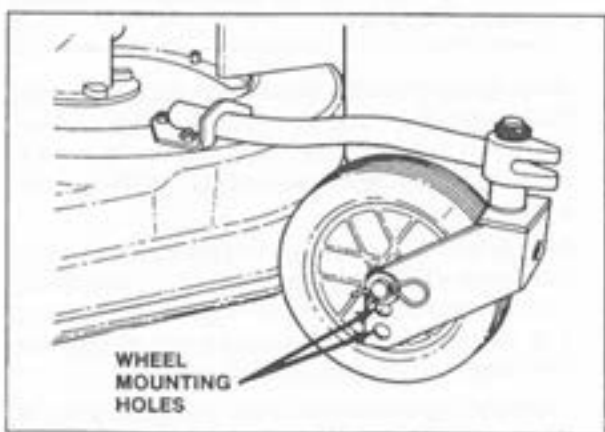

LUBRICATION

Before operating, remove the pipe plug at the top of the transmission housing. Check that the gear oil is

WARNING

Read and obey all safety rules applicable to the unit and the rotary mower in Section One. Do not remove or defeat the purpose of the discharge deflector on the Mower, or leave the discharge door open when not using the grass catcher.

Do not remove or destroy the operation of the high speed lockout device on the unit, or operate or leave the machine running with the RED STOP LEVER latched in the down position. Do not operate with the mower at the rear of the unit.

When operating from a sulky, always MOW UP AND DOWN (never across) a slope, and make wide turns to guard against tipping. When walking behind the mower, GO ACROSS (never up and down) the slopes while mowing.

- OPERATION FROM A RIDING SULKY: Only models with wheel brakes should be operated from a riding sulky. An optional wheel brake kit may be installed if your unit does not have factory-installed brakes.

WARNING

Remember that a converted unit will pull to the left when the right brake lever is depressed, and to the right when the left brake lever is depressed. Forgetting this could result in loss of control—especially on a unit in differential drive, or the model 737 where the right and left brake levers are used in making turns.

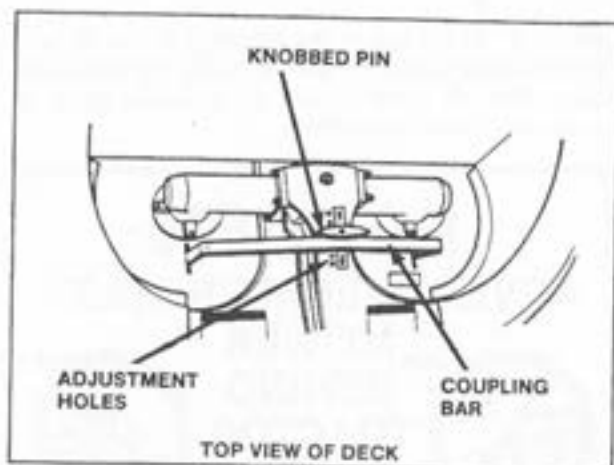

2. **CUTTING HEIGHT ADJUSTMENT:** The cutting height is set by raising or lowering the mower blades under the deck. The deck stays at the same height above ground level. To adjust the cutting height, pull up the knobbed, spring-loaded pin in the height adjustment bracket on the deck, and pin it into the desired hole of the five holes in the top of the transmission housing. (See drawing.) The hole nearest the PTO connection gives the shortest cutting height.
3. The cutting height range is 2" to 4". To avoid shock to the grass, it is recommended that only about 1/3 of the grass height, or a maximum of 2 inches, be removed at each cutting. For example, reduce a 6 inch growth to 4 inches on the first mowing, then reduce it to desired height later on with a second cutting.
4. Mowing wet lawns is not recommended because of poor results and also because it increases the potential for mildew and other grass diseases.
5. It is a good idea to vary the mowing pattern with each mowing. This will help to eliminate matting, and give a more even overall appearance than when the mowing pattern is unvaried.

INSPECTION AND MAINTENANCE

WARNING

If a hard object is stuck, shut down the engine immediately (See page 7) and inspect for a damaged blade. Do not try to straighten and remount a bent cutter, because any impact severe enough to bend it may have put tiny cracks in the hardened steel. These could enlarge until the cutter shatters during operation.

Like all cutting tools, the Mower must be kept in good condition to perform well.

1. Clean the underside of the deck often enough to prevent heavy caking of dirt and grass on the surfaces. Inspect the condition of the mower blade assemblies each time.
2. The left and right mower blade assemblies consist of fluked cutter blades mounted on both ends of blade holders by M10 x 30mm lock nuts, special "super" lock washers and self-locking nuts. The mounting imparts a flail-like action to the cutters. The left side blade assembly rotates counterclockwise (ccw) and the right side assembly clockwise (cw).

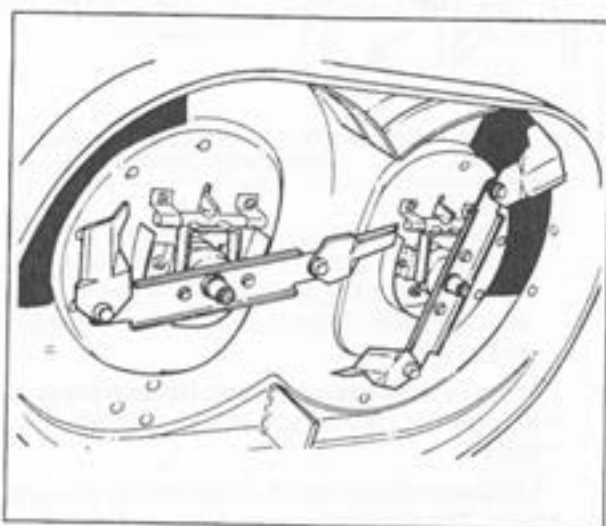

WARNING

Do not substitute ordinary fasteners for those called out in step 2.

3. An extra set of cutter blades was packaged with the Mower. Put these on the blade holders when the other set has been removed for grinding. (Cutting edges cannot be filed.) Grind the bottom edges of the cutters.
4. After grinding and remounting the cutters, check the balance of each blade assembly. If one end is heavy, remove the cutter from that end and grind it to improve blade balance. An out-of-balance condition causes excessive vibration.
5. The cutters gradually will wear thin at the bend of the flukes. Keep a watch for this. If you see cracks in this area, discard cutters before further wear occurs. Cracked pieces can break off, becoming high-velocity missiles.

USE AND CARE OF SNOW THROWERS



GENERAL INFORMATION

All sizes of Snow Throwers are similar in construction and operation. The 32" size fits only model 745. The 28" size fits models 605, 725 and 737. The 24" size fits models 602 and 715. Optional accessories include snow grips and wheel weights for added traction.

SNOW THROWER OPERATION

1. Read all precautions in Section One pertaining to the safe operation of the machine and snow thrower attachment.
2. **700 SERIES MODELS ONLY:**
 - a) On models 715, 725 and 745 in the converted mode for the Snow Thrower, the decal reading right-side-up from the operator's position marks the three positions available for Snow-Thrower operation. They are F (Forward), N (Neutral) and R (Reverse). The other positions on the selector are blocked by the **high speed lockout** (see page 31).
 - b) On models 725 and 745, the HI/LO gear range lever may be used to obtain high and low speeds in both "F" and "R" gear selections.
 - c) On the model 737 in the converted mode, three positions on the gear selector are available for Snow Thrower work. All three produce speeds slower than normal walking speed. But, only the lowest speed should be used for backing when the footing is slippery.

3. If necessary to start the engine in a barn or shed, keep the doors wide open.
4. If necessary to back up, be sure of your footing, and be sure the way behind you is unobstructed.



WARNING

Do not try to clear slopes so steep that you could lose control, or the machine could slide into you or an obstruction.

The snow-thrower has an impeller retard system designed to brake the impeller to a stop within three seconds after PTO disengagement or engine shutdown. Even so, never put hands and fingers inside the discharge chute or the impeller (collector) area unless the engine has been rendered unstartable, as explained in Section One, page 8.

5. Always shut off the engine, wait until all movement stops, and disconnect the spark plug wire before deicing the discharge chute or the impeller. The wooden stick on the side of the Snow Thrower is for deicing. You also can let the machine thaw if a warm place is available.
6. Always be sure to direct the discharge chute away from living quarters, vehicles and people. Work in a pattern which will pile the snow where desired, and which requires the fewest passes with the machine. With the wrong procedure, you could be throwing snow over and over without clearing the area. Don't forget that the wind has an influence on how you should proceed.

USE AND CARE OF CHIPPER/SHREDDER

Be sure to read the BCS Chipper/Shredder Owner's Manual which comes with the attachment, and also obey the safety messages printed on the unit and the Chipper/Shredder attachment. This unit reduces thick branches to chips, and pulverizes lawn and garden waste for mulching or adding to your compost pile. Careless or improper use can be very dangerous.

Wear safety goggles of the type specified by ANSI Safety Standard Z87. Also wear a hat. Work gloves may be worn when feeding the Chipper, but not when feeding the Shredder, because they can pull your hands into the hopper if snagged by the material. Remove jewelry or clothing articles which could be drawn into the machine.

Set up on firm ground, but not on gravel, concrete, brick or other surfaces which provide no cushion.

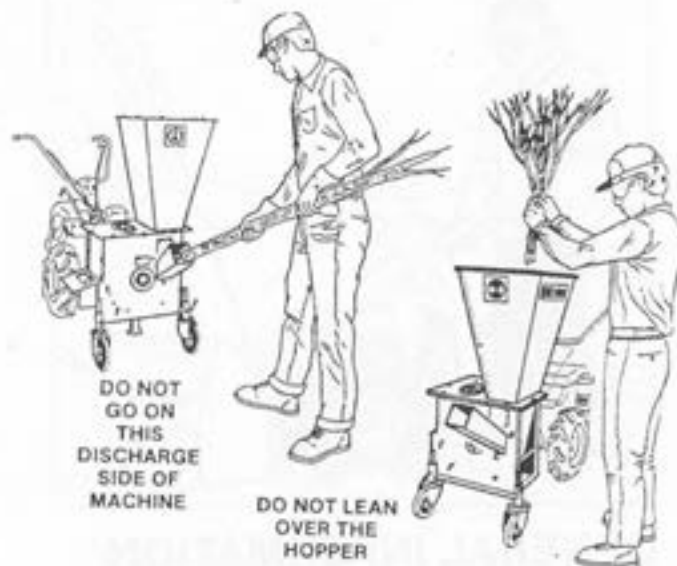

DANGER

Do not start engine when there is material in the Shredder. Shut off engine and disconnect the spark plug wire before cleaning a jammed hopper, changing screens or performing any maintenance or service.

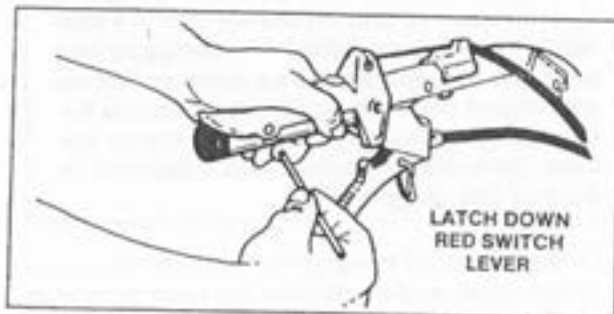

After latching the clutch and stop switch and starting the engine, leave the unit in neutral. Disengage the clutch lever while pinning down the stop switch lever (See drawing). Engage the PTO when ready to operate.

Be careful what you put into the Shredder hopper. The machine can shred most organic materials. However, objects of certain shape, size, or texture may cause trouble even if organic. The Shredder cannot handle thick branches or large chunks of wood. Neither Shredder nor Chipper can handle cloth, string, glass, rubber, metal, rocks or paving, or long vines.

Soggy soil, green garden wastes and wet grass clippings can be processed through the Shredder by mixing dry leaves and wood chips with the wet stuff. For wet processing, the standard curved screen with the "Swiss cheese" holes should be replaced with the set of five rods and tubes supplied with the attachment.

DANGER

Do not use the Chipper/Shredder with an un-screened discharge. The discharge must be covered either with the rods and tubes or the standard screen.

IMPORTANT

Always disengage the PTO lever before stopping the engine. If the PTO remains in engagement during engine shutdown, the rotating Chipper/Shredder shaft may motorize and restart the engine. After shutdown, always check the paint splash across the drive shaft (near Chipper chute) to be sure all movement has stopped.

CHIPPER/SHREDDER MAINTENANCE

1. Clean out the hopper before each use.
2. Clean the exterior at regular intervals, and apply a light oil or wax to prevent rust.
3. Shaft bearings are the sealed, self-lubricating type requiring no further lubrication.
4. Check all fasteners frequently and tighten loose parts. Replace missing or worn parts. See the illustrated parts list in your Chipper/Shredder owner's manual for parts information.

USE AND CARE OF POWER SWEEPER

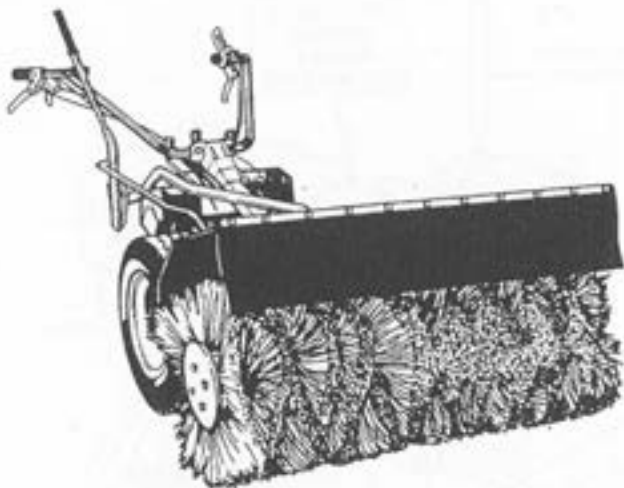

Be sure to read and follow the detailed instructions in Power Sweeper Operator's Manual (No. 101.00915) that came with the attachment. Also follow the instructions for safe use of 600/700 series units and the Power Sweeper attachment in Section One of this manual.

Your unit should have an 8 horsepower or larger engine to power the Sweeper. Installation of a pre-cleaner element in the engine air cleaner is recommended.

Safety equipment must include eye protection goggles of the type stamped "Z87" (for ANSI Safety Standard Z87).

A dust mask or respirator should be worn when sweeping surfaces where dust is raised.

Keep children, pets and bystanders away from the machine, and keep well clear of the rotating parts.

NOTICE

In your Power Sweeper owner's manual, the instructions to deactivate the PTO lockout device for front operating attachment applies to earlier units than those of your model year. On your unit, PTO lockout deactivation is not only unnecessary, but also must not be done. On your unit, the lockout is effective only when needed. In the front-drive mode, the lockout is inactive.

OPERATION

Move to the work site and adjust the casters for proper brush height; brush should touch flat, paved surfaces; should barely clear the turf when removing lawn thatch. If adjusted too low, or when it runs into a hillock, the brush will drive the unit back towards the operator.

Always put the unit into gear before engaging the PTO. If the Sweeper is engaged first, and the brush is in contact with the ground, it will drive back the unit.

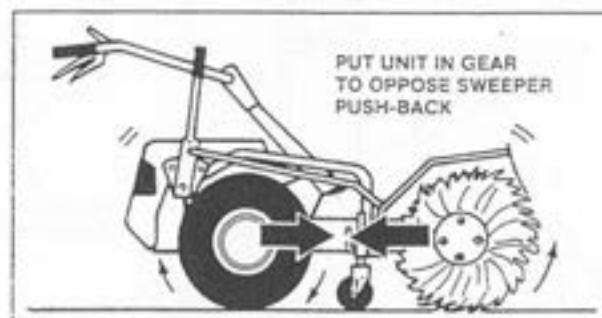

Be prepared to let go of the controls to stop all motion if the unit is driven backwards or you lose control.

Disengage the PTO and walk behind the unit when going up or down slopes. Work across the slope when sweeping. Do not work on terrain where you cannot keep your footing or control of the unit. It could overturn or slide into you. For rooftop sweeping, be sure the surface is dry and does not pitch more than 5 degrees (1/2" per foot). Set up warning barriers so you will know when you come near the edges of the roof.

MAINTENANCE AND STORAGE

Grease the PTO shaft coupling, the U-joint and the quick hitch at the same time as you repack the unit PTO coupling with grease. Also maintain the level of gear oil in the Sweeper transmission per instructions on page 33.

Clean the Power Sweeper prior to storage, and apply auto wax or other rust preventative to the exterior surfaces. Store in a dry, well-ventilated place.

All parts of the Power Sweeper are available from your BCS dealer or distributor. See the illustrated parts list in the Power Sweeper owner's manual for parts identification.

USE AND CARE OF DOZER BLADE

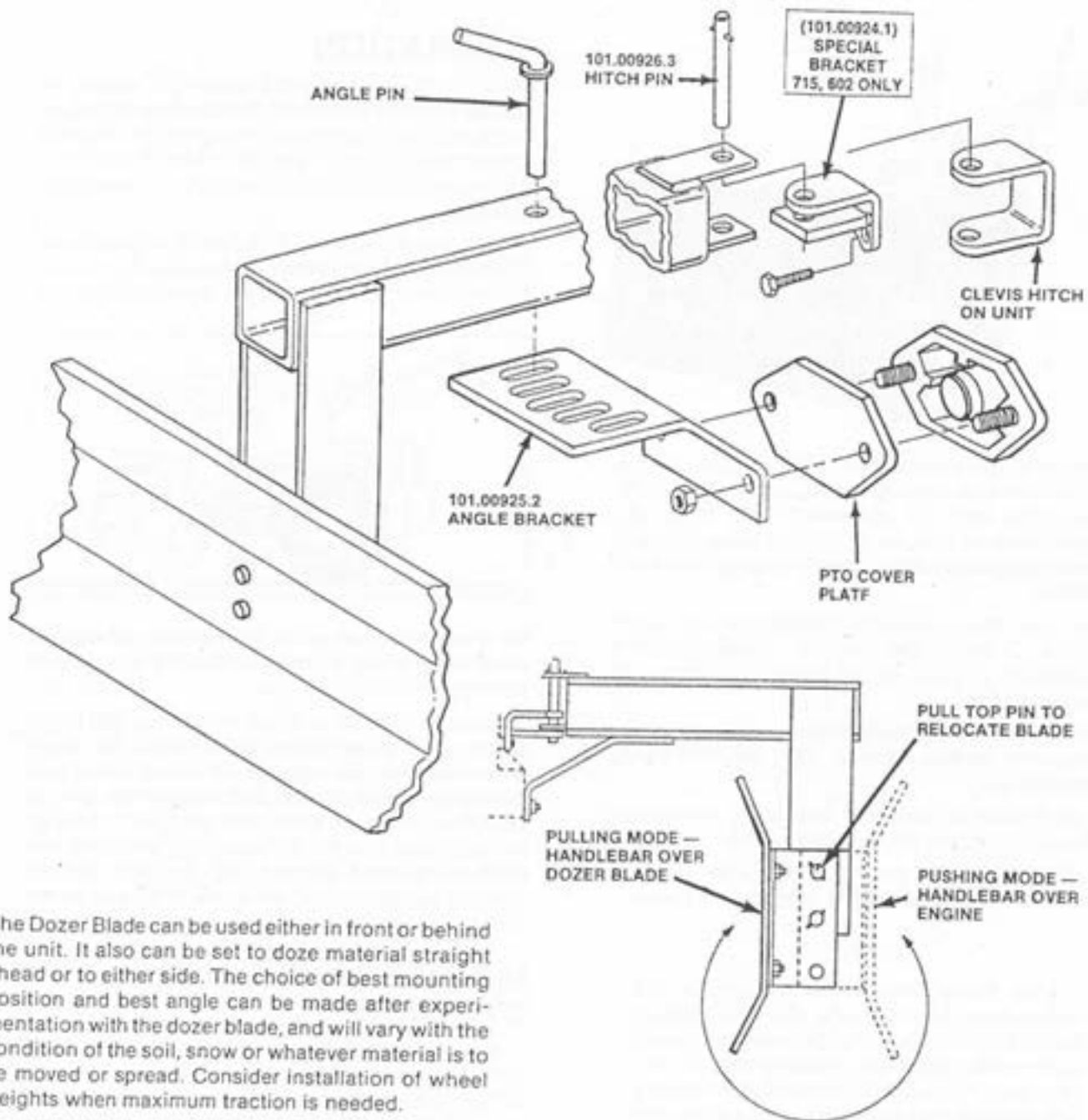

The Dozer Blade can be used either in front or behind the unit. It also can be set to doze material straight ahead or to either side. The choice of best mounting position and best angle can be made after experimentation with the dozer blade, and will vary with the condition of the soil, snow or whatever material is to be moved or spread. Consider installation of wheel weights when maximum traction is needed.

Instructions for assembly and use come with the Dozer Blade. Special bracket (101.00924.1), supplied for models 602 and 715, is to be bolted to the transmission bosses above the PTO flange with two M8 x 20mm bolts. Other models have an integral mounting bracket. The unit was shipped with a plate covering the PTO. Put this plate back on the PTO studs before mounting the angle bracket on the studs. Do not tighten the nuts at this time. Fit the dozer blade tongue over the hitch (or special bracket)

on the unit, and drop the hitch pin through the holes. Drop the angle pin through the tongue hole into one of the slots in the angle bracket. Now tighten the PTO stud nuts.

NOTE

The PTO plate should be used to protect the PTO during use of the Dozer Blade. It also can be installed to keep the grease clean during unit storage.

**SAVE THIS MANUAL
FOR REFERENCE.**

Accessories for **BCS** Power Units & Attachments

UTILITY TRAILER

Use with any 700 series power unit. Attaching bracket is necessary only for model 715. Hauls up to 875 pounds of firewood, trash, shrubs, etc. Has a separate footbrake for operating safety. Not for road use.

Trailer #921.48685
Bracket #922.43805

TRANSPORT SULKY

For all 700 series power units for transport of machine and operator to the work site. Not for work applications or road use. A curved coupling is used for attachment to the unit hitch. Model 715 requires an optional hitch and pin assembly for the curved coupling.

Sulky #921.48675
Curved Coupling #922.43791
Hitch & Pin #922.49997 (for 715)
Curved Coupling #922.47720 (737)
Curved Coupling #922.48767 (745)

MOWING SULKY

Converts your walking BCS Rotary Mower Attachment to a riding mower. For either 600 or 700 series power units. Part #921.48775 (Not for 602 and 715-725)

WHEELS AND TIRES

Many sizes and types are available to suit your needs. Ask your BCS servicing dealer for complete information.

STEEL CAGE WHEELS

For additional traction in loose or wet soils.

17" size - #922.43682 (for 715-602)
19 1/2" size - #922.42474 (All either)

NARROW NURSERY STEEL WHEELS

For cultivating narrow rows, these wheels reduce track width, enabling operator to till 12" or 8" rows.

Part #922.43683 (for 715)

TILLER TINES

The standard tines supplied with the attachment have been proved over many years to be ideally suited for most soil types. Special tines are also available for special conditions. Ask your servicing dealer for complete information.

TRANSPORT WHEEL

Providing fast, easy maneuvering, this rubber-tired wheel is mounted on 700 series tractors by an easy-to-remove-or-install "presto" pin.

Part #922.42465

WHEEL WEIGHTS

Available in various weights for different wheel sizes, weights mount into the wheels for increased traction and/or deeper plowing or tilling.

Part #922.43686 for 4.00-8
Part #922.48715 for 4.00-10 & 5.00-10
Part #922.48720 for 6.5/80-12"

SINGLE BOTTOM PLOW

Will plow a furrow from 6" to 10". Size 6.5/80-12 tires and wheel weights are recommended for plowing.

Part #921.42452

SWIVEL PLOW

Reversible plow allows gardener to return down next plow row. 6.5/80-12 tires and wheel weights are recommended.

Part #921.42454

ADJUSTABLE RIDGER

Will make furrows 4" to 12" wide and 4" to 8" deep. Ideal for seed planting and forming irrigation ditches.

Part #921.42456

PTO EXTENSIONS

Available in 3" and 6" lengths needed for certain applications with a Rotary Mower or Cutter Bar Mower Attachment on diesel engine power units.

Part #922.00010 (three inch)
Part #922.00014 (six inch)
Part #922.48748 (three inch for 745)
Part #922.48734 (six inch for 745)

SNOW GRIPS

They provide additional traction during operation of the Snow-Thrower Attachment. Various sizes are available. See your servicing dealer.

Part #922.48328

FRONT WEIGHT

Mounts below the weather hood to add weight and traction to the power unit. 700 series.

Part #922.48719

HILLER/FURROWER

Two tools in one, Furrower has removable tiller wings so it can be used separately. Easily attaches to the Tiller hood by a "presto" pin.

Part #921.47860

COMBINED RIDGER

Used in combination with Tiller tines, replaces the original tiller hood.

Part #921.43785

DOZER/SCRAPER BLADE

Can be pushed or pulled. Easily converts by "presto" pin. Angles are adjustable.

Part #101.00232

BUMPERS

Protect engine from walls and fence posts. Bumpers vary in size according to model. See your servicing dealer for information.

CUTTER BAR BLADE GUARD

To be installed on Cutter Bar Mower when not in use. Protects operator. See servicing dealer for part number.

WHEEL SPACERS

Placed on wheel axles, these 2.5" spacers increase track width by 5".

Part #922.43685

ADJUSTABLE WHEEL EXTENSIONS

A pair of these will increase the track width by as much as 8 inches.

Part #922.48700

LOCK-OUT HUBS

Used to equip model 715 or 725 with free-wheeling feature. Also increases track width.

Part #922.43817

BRAKE

Available in kit form for models 602, 715 and 725. Other models have factory-installed brakes.

Part #922.43816

PTO ADAPTOR

Converts the standard BCS PTO shaft to the American standard 1-3/8", 6-spline size.

Part #922.48721

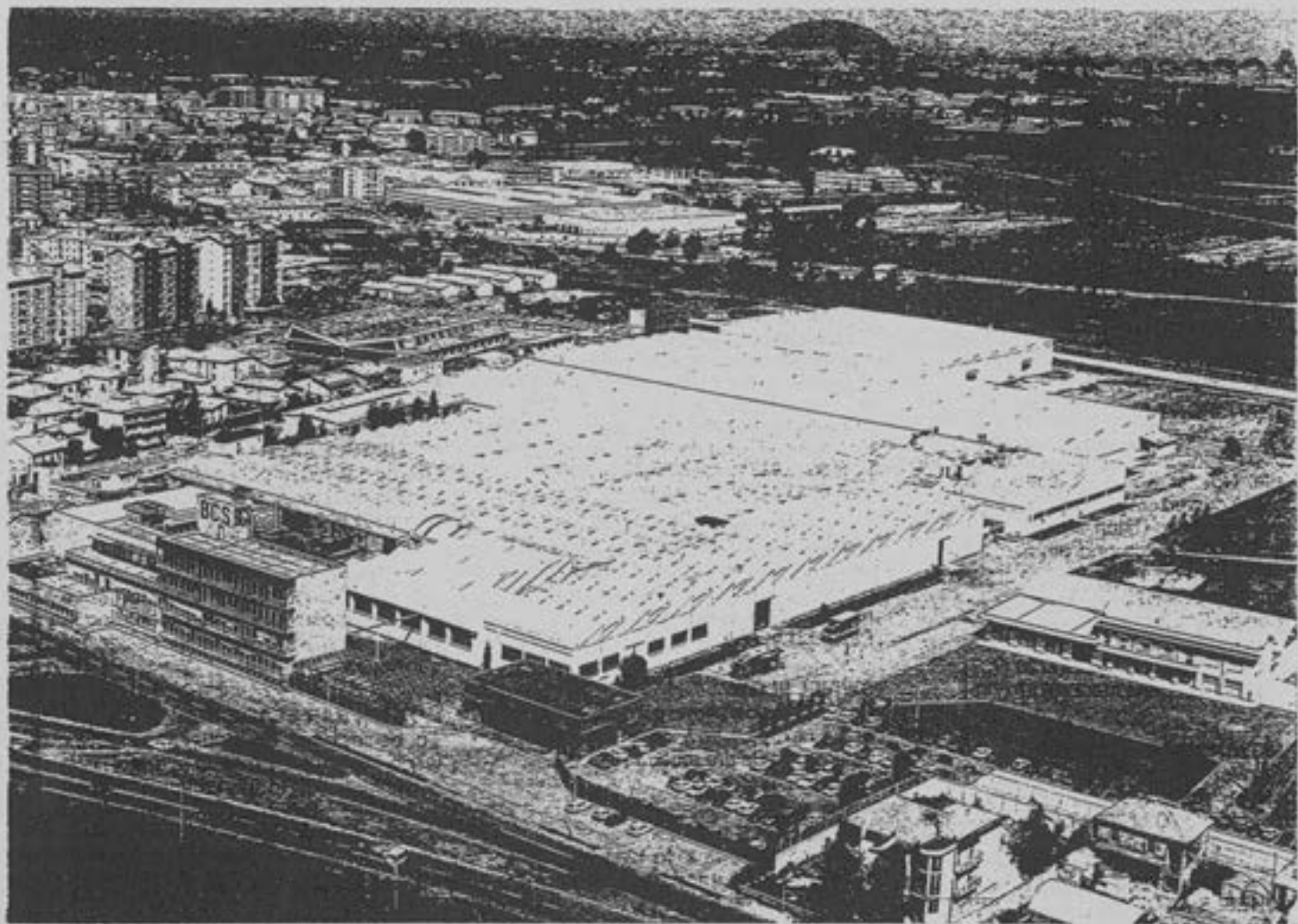

A leading manufacturer of tractors and farm implements for the past 50 years, BCS operates from this 50-acre facility near Milan, Italy.



BCS AMERICA, LLC
8111 NE COLUMBIA BLVD.
P.O. BOX 18000
PORTLAND, OR 97218
(503) 252-1249
FAX: (503) 252-8360

10-3993
901.00005