

Visualizing Quality Control with Manhattan Mounts

Universal Flat-Panel TV Articulating Wall Mount

Model #461375



REACH OUT FOR A BETTER VIEW

44 lbs / 20 kg
Holds Up To 44 lbs. (20 kg)

13"-27"

Holds One 13"-27" TV

-12° to +5° tilt,
±90° swivel

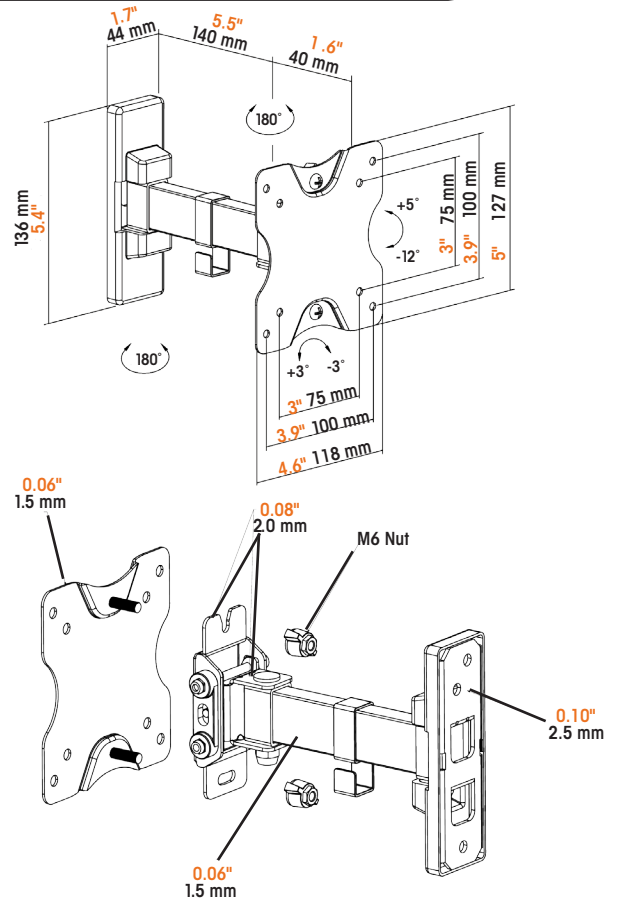

- Securely holds one flat-panel television
- Solid steel construction
- Easy installation ideal for home, office and commercial applications



For more information, visit
manhattanproducts.com