



High Speed HDMI Extension Cable

HDMI Male to Female, Shielded, Black

High-speed cables deliver high-definition performance.

HDMI has become the standard digital connection, delivering the highest-quality audio and video signal over a single cable. MANHATTAN® High Speed HDMI Cables are designed and carefully constructed to meet the evolving needs of the high-definition marketplace. MANHATTAN High Speed HDMI Shielded Cables provide the highest resolution possible at 4K x 2K, an audio return channel and a bandwidth of 10.2 Gigabits per second at 340 MHz. These high quality cables provide high-definition video and multi-channel, digital audio with increased performance characteristics, greater accuracy and expanded features. No matter if you need device cables, extension cables, or mini or micro connections, MANHATTAN has your High Speed HDMI Cables covered.

Model	Length
308427	1.8 m (6 ft.)
322911	3 m (10 ft.)
322935	5 m (16.5 ft.)
322942	7.5 m (25 ft.)

Lifetime Warranty

Strict manufacturing standards ensure the highest quality in all MANHATTAN products. All items carry a full Lifetime Warranty — the strongest quality commitment anyone can make.

Model
308427
322911
322935
322942



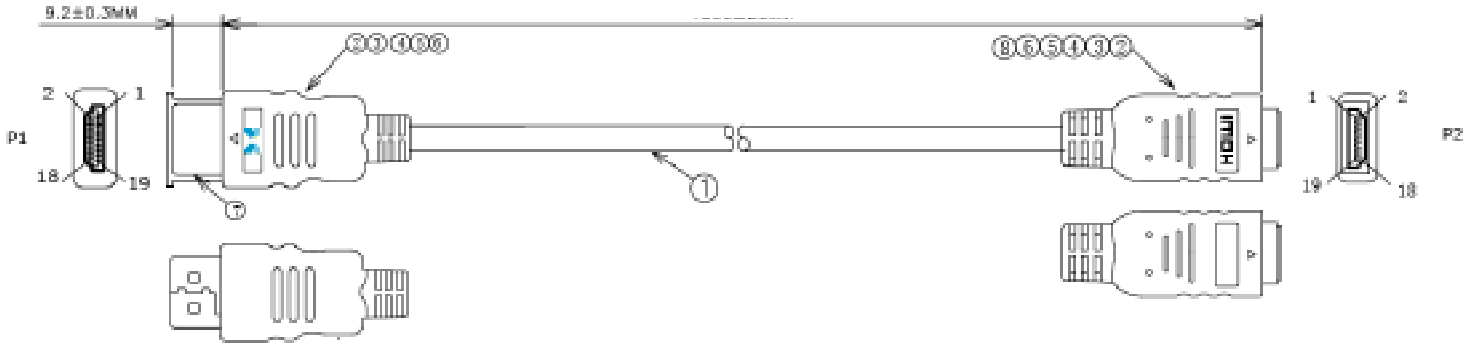

ELECTRICAL TEST:
 1.100% OPEN & SHORT & MIS WIRE TEST
 2.CONTACT RESISTANCE:2 OHM(MAX)
 3.INSULATION RESISTANCE:10M OHM(MIN)
 4.HI-POT TEST:DC 300V/10ms

THESE DRAWINGS AND SPECIFICATIONS ARE THE PROPERTY OF MANHATTAN AND SHALL NOT BE REPRODUCED, COPIED OR USED IN ANY MANNER WITHOUT THE PRIOR WRITTEN CONSENT OF MANHATTAN.

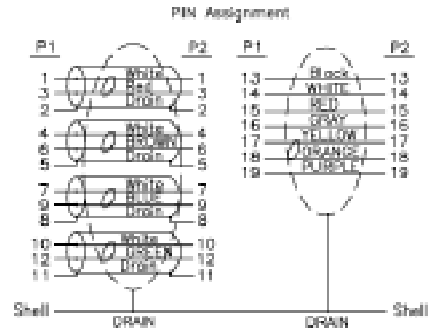

NO	CELINK P/N	DESCRIPTION	Q'TY	UNIT	REV.	DESCRIPTION	DATE
8	A2-R0200B3	HDMI 19P FEMALE SOLD TYPE BLACK INSULATION SHELL NICKEL PLATED	1	PCS			
7	A6-0000015	HDMI COVER TRANSPARENT	1	PCS			
6	A10-R075133	BLACK SHRINK TUBE #1.5*16MM	2	PCS			
5	A10-R075130	BLACK SHRINK TUBE #3.5*16MM	8	PCS			
4	A5-R047001	BLACK 45P PVC	16	G			
3	A5-R047011	TRANSPARENT PE	3	G			
2	A2-R0200A2	HDMI M 19P SOLDER TYPE BLACK INSULATION SHELL NICKEL PLATED	2	PCS			
1	A4-R001349	UL20278(30AWG*1PR+6AWG*4C+30AWG*1PR+30AWG*5C+AEI)(50%) 00±0.5MM BLACK (1.3b)	1.8	M			
NO	CELINK P/N	DESCRIPTION	Q'TY	UNIT	APP'D BY	DATE	2008.05.27

REV.	DESCRIPTION	DATE
1	TOLERANCE INCHES M/M	
X	.015 .30	
.XX	.010 .10	
.XXX	.005 .05	

MANHATTAN

TITLE:

CUSTOMER ;

CUSTOMER P/N:

SCALE NONE DRAWING NO:

UNIT MM

DATE 2008.05.27

REV A

1/1

Features

- HDMI 19-pin male to HDMI 19-pin female connections
- Ensures the integrity of the signal between HDMI devices
- Supports HD resolutions beyond 1080p and Deep Color
- Compliant with High Speed HDMI specifications
- Up to 10.2 Gbps at 340 MHz bandwidth
- Fully shielded to reduce EMI and other interference sources
- Molded PVC boot
- Lifetime Warranty

Specifications

STANDARDS / CERTIFICATIONS

- UL 20276
- ISO 9002
- RU
- CE

GENERAL

- Bandwidth: 10.2 Gbps
- 340 MHz
- Meets or exceeds existing HDMI standards
- Length: listed on Page 1

CONTACTS

- 1 x HDMI 19-pin male
- 1 x HDMI 19-pin female

- Nickelplated contacts
- Molded PVC boot
- Shielded, aluminum and braided
- 28 AWG connectors

ELECTRICAL

- Current rating: 0.5 A DC
- Withstanding voltage: 300 V DC
- Insulation resistance: 50 MOhms
- Conductive resistance: 2 Ohms
- Thermal plastic casing

PACKAGE CONTENTS

- High Speed HDMI Extension Cable

For more information on MANHATTAN products, consult your local dealer or visit www.manhattan-products.com.



Copyright © MANHATTAN

