

SATA Power Splitter

15-Pin SATA Power to Triple 15-Pin SATA Power

Powerful internal connections for computing solutions.

MANHATTAN® SATA Power Cables, Adapters and Splitters easily connect and extend the reach between a power supply unit and other critical internal components. Ideal for new systems, replacement and upgrade applications, MANHATTAN offers an assortment of internal connection solutions in various configurations all carefully engineered from quality materials to deliver and maintain reliable power distributions. Featuring durable jackets and heavy-duty, fully-molded construction, MANHATTAN SATA Power Cables, Adapters and Splitters help provide and deliver maximum electrical conductivity to transmit dependable power where and when it's needed.

Lifetime Warranty

Strict manufacturing standards ensure the highest quality in all MANHATTAN products. All items carry a full Lifetime Warranty — the strongest quality commitment anyone can make.

Model
308960



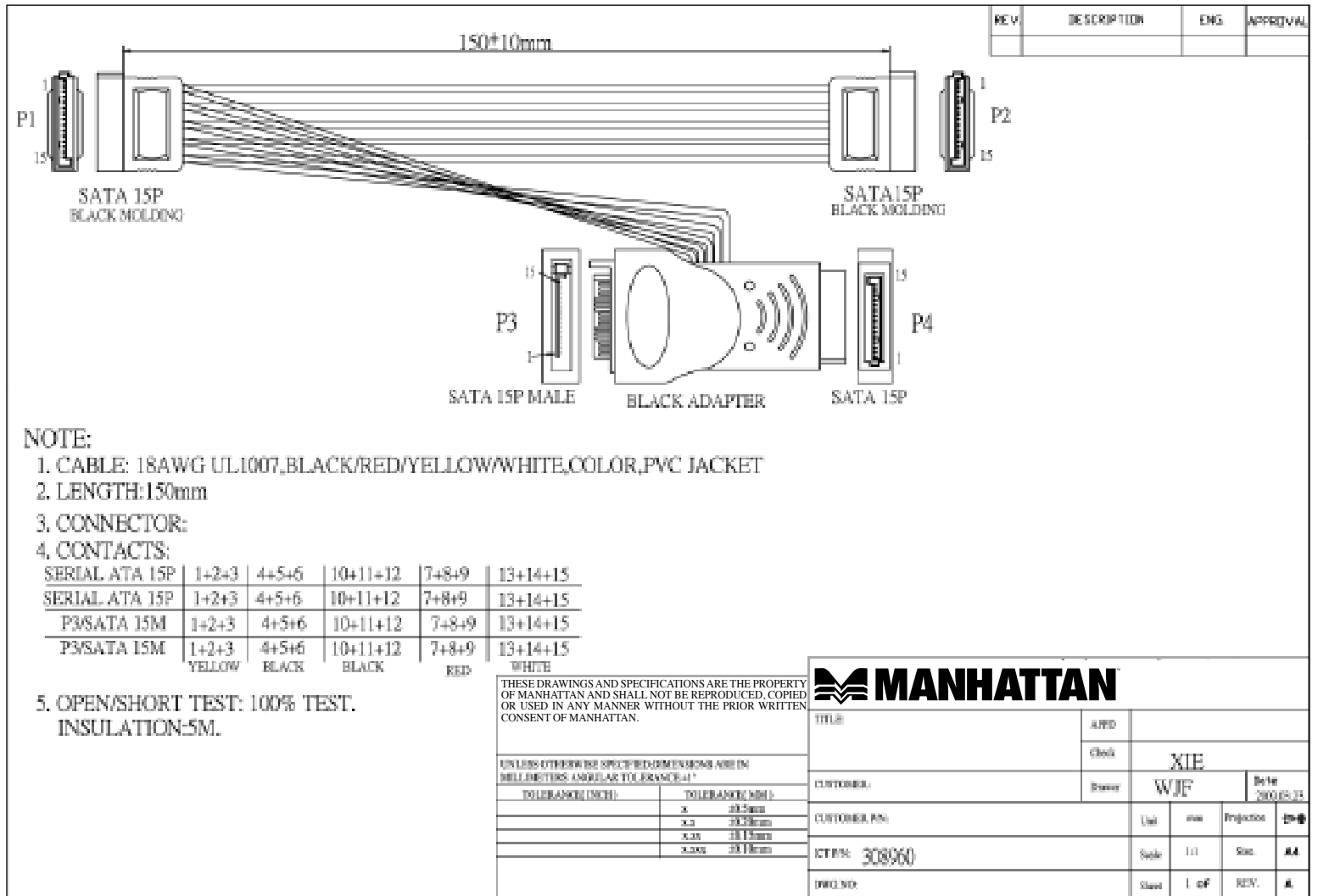

Features

- Converts standard a SATA 15-pin power lead to (3) additional 15-pin SATA power connections
- Creates additional power connections from existing SATA sources
- Gold-plated SATA connector
- Molded PVC boot
- Lifetime Warranty

Specifications

STANDARDS AND CERTIFICATIONS

- RU
- CE

CONTACTS

- (1) 15-pin PCB
- (3) 15-pin SATA male
- Gold-plated SATA connector
- Molded PVC boot

CABLE

- Thermal plastic casing
- 18 AWG cable
- Withstanding voltage: 300 V DC

DIMENSIONS

- Cable Length: 30.5 cm (12 in.)
- Adapter: 6 x 3.6 x 1.3 cm (2.4 x 1.4 x 0.5 in.)

PACKAGE CONTENTS:

- SATA Power Adapter

For more information on MANHATTAN products, consult your local dealer or visit www.manhattan-products.com.



Copyright © MANHATTAN

