

with Installation Instructions

# Owner's Manual

## Banks Monster<sup>®</sup> Exhaust System

**2007-2009 Dodge 6.7L Cummins (All) ISB Pickup Trucks Including Mega Cab**

**2010 Dodge 6.7L Cummins Crew Cab Short Bed (6'4" Bed) & Crew Cab Long Bed (8' Bed)**

**2011 Dodge 6.7L Cummins Crew Cab Long Bed (8' Bed) & Mega Cab Short Bed (6'4" Bed)**

THIS MANUAL IS FOR USE WITH SYSTEMS 49764, 49768 & 49774

Gale Banks Engineering  
546 Duggan Avenue • Azusa, CA 91702  
(626) 969-9600 • Fax (626) 334-1743

Product Information & Sales: (888) 635-4565  
Customer Support: (888) 839-5600  
Installation Support: (888) 839-2700

**bankspower.com**



# General Installation Practices

Dear Customer,

If you have any questions concerning the installation of your Banks Power System, please call our Technical Service Hotline at (888) 839-2700 between 7:00 am and 4:00 pm (PT). If you have any questions relating to shipping or billing, please contact our Customer Service Department at (888) 839-5600.

Thank you.

**1.** For ease of installation of your Banks system, familiarize yourself with the procedure by reading the entire manual before starting work.

**2.** The general assembly diagram (**Figure 1**) provides only general guidance. Refer to each step and section diagram in this manual for proper instruction.

**3.** Throughout this manual, the left side of the vehicle refers to the driver's side, and the right side to the passenger's side.

**4.** Disconnect the ground cable from the battery (or batteries, if there are two) before beginning work.

**5.** Route and tie wires and hoses a minimum of 6" away from exhaust heat, moving parts and sharp edges. Clearance of 8" or more is recommended where possible.

**6.** When raising the vehicle, support it on properly weight-rated safety stands, ramps or a commercial hoist. Follow the manufacturer's safety precautions. Take care to balance the vehicle to prevent it from slipping or falling. When using ramps, be sure the front wheels

are centered squarely on the topsides; put the transmission in park; set the hand brake; and place blocks behind the rear wheels.

**CAUTION! Do not use floor jacks to support the vehicle while working under it. Do not raise the vehicle onto concrete blocks, masonry or any other item not intended specifically for this use.**

**7.** During installation, keep the work area clean. Do not allow anything to be dropped into intake, exhaust, or lubrication system components while performing the installation, as foreign objects will cause immediate engine damage upon start-up.

## Tools Required:

- 1/2" and 3/8" drive ratchets with inch and metric sockets and 1/2" and 3/8" drive extension
- Inch and metric combination or open-end wrenches
- Standard screwdriver
- Clean shop towels or rags
- Pry-bar

## Highly recommended tools and supplies:

- Inch-pound and foot-pound torque wrenches
- oxy-acetylene torch
- Penetrating oil or light lubricant spray

# Products available from Banks Power for the 07-11 Dodge 6.7L

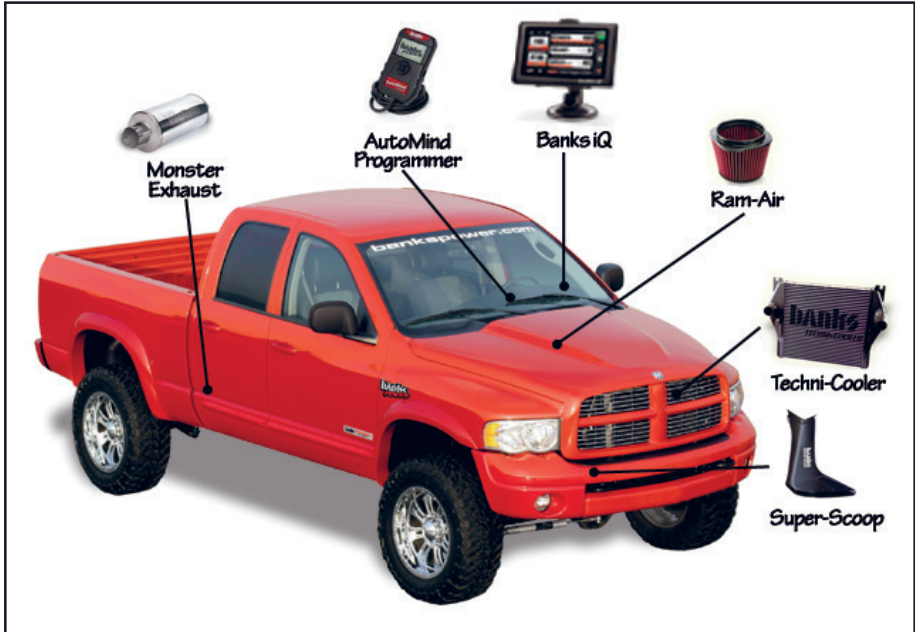

## **Banks iQ System (P/N 61201)**

- 5" touchscreen interface
- Interchangeable gauge display, read and clear codes, monitor engine diagnostics, log data, time your vehicles runs and much more.

## **Banks Ram-Air Intake System (P/N 42175, 42180, 42178)**

- Increases your airflow over stock.
- Adds power, improves fuel economy, lowers EGTs and reduces smoke.

## **Banks Ram-Air Intake Super-Scoop (P/N 42190, 42191)**

- Adds cooler denser air to the Ram-Air Intake housing, further increasing fuel economy, reducing smoke and lowers EGTs.

## **Banks Techni-Cooler® System (P/N 25983)**

- Provides increased air flow to the engine by increasing air density for more increased power, lower EGTs and improved fuel economy.

## **Banks AutoMind Programmer (P/N 66108)**

- Clear and view OBDII Diagnostic Trouble Codes (DTC).
- Loaded with dyno-proven tuning files
- Speed Limiter adjustment capabilities
- Recalibration of the speedometer
- Customize and adjust gearing, tire size and fuel octane

**For More Information please call (888) 635-4565  
or Visit us online @ [www.bankspower.com](http://www.bankspower.com)**

# General Assembly Diagram

ITEM #	PART #	DESCRIPTION	QTY
1	53298	Intermediate Pipe	1
*2	53305	Extension Pipe	1
	53279	Tailpipe, Front	1
3	53325	Tailpipe, Front (2009 SCLB & CCLB Models only)	1
	53280	Tailpipe, Rear	1
4	53226	Tailpipe, Rear (2009 SCLB & CCLB Models only)	1
	52383	Tailpipe Tip	1
5	52726	Tailpipe, Tip (2009 SCLB & CCLB Models only)	1
6	52471	Exhaust Band Clamp, 4"	1
*7	52476	Exhaust Clamps, 4"	2
8	53750	Rear Hanger Clamp	1
9	96009	Urocal, Banks Power	2

\* For 2010 -2011 CCLB Models Receive Extension Pipe 53305 and 3 Exhaust Clamps 4".

Figure 1

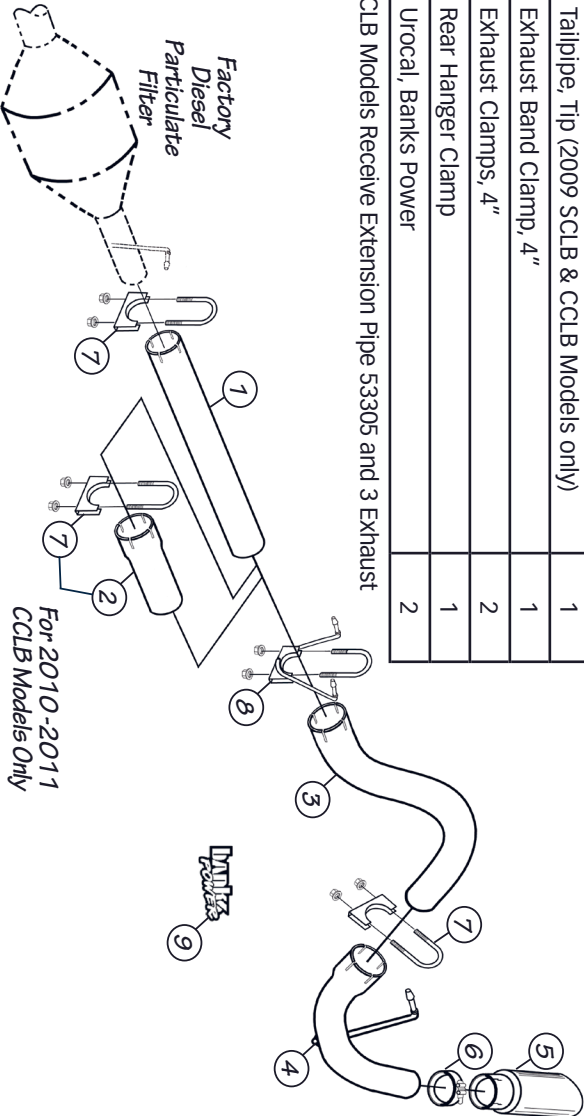

# Monster Exhaust System Installation

**1.** As a precaution, disconnect the ground of the battery (if there is more than one battery, disconnect both).

**2.** Raise the vehicle and support it with properly weight rated safety stands, ramps or a commercial hoist. Follow the manufacturer's safety precautions. Take care to balance the vehicle to prevent it from slipping or falling. When using ramps, be sure the front wheels are centered squarely on the topsides; place the transmission in park; set the parking brake and place blocks behind the rear wheels.

**CAUTION: DO NOT WORK UNDER ANY VEHICLE SUPPORTED ONLY BY A JACK. SEVERE INJURY MAY RESULT.**

**WARNING! The following step may require the use of a torch and/or saw. Proper safety equipment should be used. Failure to use proper safety equipment may result in severe injury.**

**3.** Starting at the rear of the vehicle, remove the tailpipe near the intermediate pipe clamps by cutting through the connection or by removing the clamps and heating the joints with an oxy-acetylene torch to allow crimped pipes to separate. Remove the tailpipe from the vehicle.

**4.** Remove the clamps on the Diesel Particulate Filter to front intermediate pipe. **TAKE CAUTION TO NOT CUT OR DAMAGE DIESEL PARTICULATE FILTER TUBING DURING THE REMOVAL PROCESS.** Separate the intermediate pipe to Diesel Particulate Filter connection.

*NOTE: The use of an oxy-acetylene torch may be necessary. Remove the intermediate pipe hanger pins from the rubber hangers with a pry bar (Spray lubricant will ease hanger removal) and remove the intermediate pipe assembly*

*from the vehicle.*

**5.** Locate the supplied intermediate pipe and cut the intermediate pipe based on the following configurations. See **Table 1**. Cut the NON-swaged end of the intermediate pipe. See **Figure 2**.

**6.** Install a 4" exhaust clamp over the inlet of Banks intermediate pipe. Install the intermediate pipe onto the Diesel Particulate Filter outlet. Loosely snug the 4" clamp.

**7. For 2010-2011 CCLB models only, all others skip to next step.**

Locate a 4" exhaust clamp and the supplied Banks extension pipe. Install the clamp over the extension pipe inlet and install onto the Banks intermediate pipe. Loosely snug the 4" clamp.

**8.** Install the rear hanger clamp onto the intermediate pipe or extension pipe outlet with the hanger pins facing the front of the vehicle. Insert the two (2) hanger pins into the rear rubber hangers and adjust the hanger clamp to a position that best supports the intermediate pipe. (see **Figure 3**).

**9.** Route the front tailpipe over the rear axle housing and install onto the intermediate pipe outlet. Be sure that the two pipes are completely engaged. Loosely snug the 4" hanger clamp. **8.** Install a 4" exhaust clamp onto the inlet of the rear tailpipe. Install the rear tailpipe onto the outlet of the front tailpipe. Insert the rear tailpipe hanger pin into the factory rubber hanger. Rotate the tailpipe until the hanger pins are parallel with the frame mounted pin. Slide the 4" clamp and position as shown in **Figure 3**. Loosely snug the 4" clamp.

*Notes: Maintain an adequate air gap clearance of one (1) inch between the exhaust and the shock absorber and between the exhaust and the spare tire.*

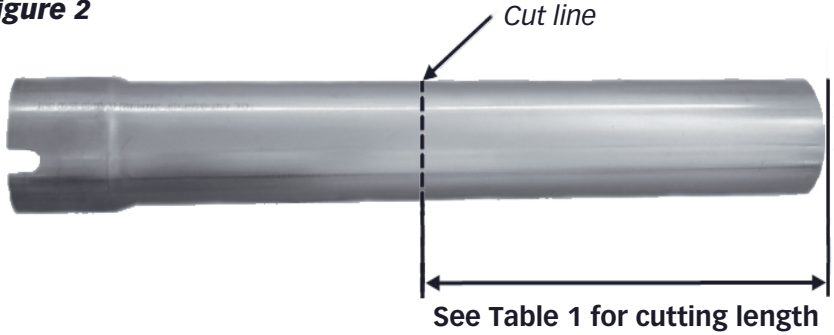
**Figure 2****Table 1**

<b>2007-2009 Dodge 6.7L Cummins</b>		
	Wheel Base 2007-2009	Cut this length from the Intermediate Pipe. See <b>Figure 2</b> .
Mega Cab/ Short Bed	160.5"	No Cut
Quad Cab/ Long Bed	160.5"	No Cut
Quad Cab/ Short Bed	140.5"	21.75"
Regular Cab/ Long Bed	140.5"	21.75"
<b>2010 Dodge 6.7L Cummins</b>		
	Wheel Base 2010	Cut this length from the Intermediate Pipe. See <b>Figure 2</b> .
Crew Cab/ Short Bed	149.5"	12"
Crew Cab/ Long Bed	169.5"	No Cut
<b>2011 Dodge 6.7L Cummins</b>		
	Wheel Base 2011	Cut this length from the Intermediate Pipe. See <b>Figure 2</b> .
Mega Cab/ Short Bed	160.5"	No Cut
Crew Cab/ Long Bed	169.4"	No Cut

**Figure 3**

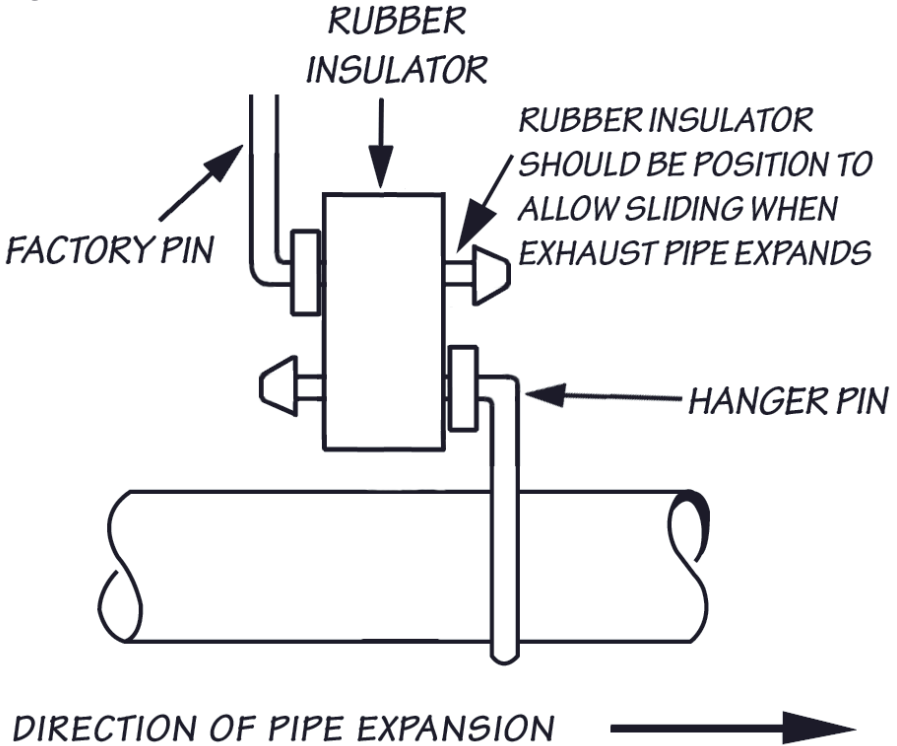

Minimum distance between exhaust tip and body is one (1) inch. 9. Adjust each of the pipes to ensure that all of the hanger pins are parallel with the frame mounted pins and that the rubber hangers are all positioned slightly forward (**Figure 5**). The amount of forward angle on the rubber hangers should increase the farther downstream the hanger is positioned. This allows the hangers to be properly positioned once the exhaust system reaches operating temperature.

**10.** **Figure 4** illustrates the proper location of an exhaust clamp on a tubing joint. Torque the nuts on each of the exhaust clamps to 35 ft-lb.

Note: The clamps only need to be tight enough to form a seal and hold the pipes together. Over tightening the clamps may cause the system to leak due to the pipe being crimped.

*Note: If installing optional tailpipe tip, cut off 4" from the tailpipe outlet before installing the tailpipe into Banks Monster Muffler. See **Figure 6**.*

**If not installing the optional Banks Tailpipe Tip, skip to step 13.**

**11.** Insert the optional tailpipe tip over the tailpipe outlet. Adjust the tip past the edge of the body or where aesthetically pleasing. Torque the band clamp to 35 ft-lb.

**Figure 4**

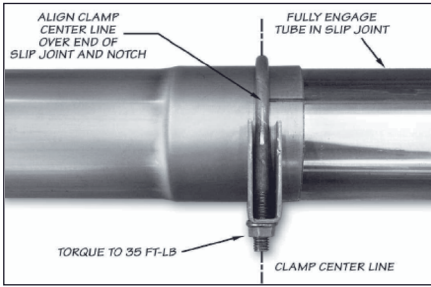

**12.** Remove the protective covering from the tailpipe tip.

**CAUTION: The protective covering may ignite and burn if not removed prior to running the engine.**

**13.** With everything positioned properly, begin to tighten the clamps starting with the ones closest to the turbo and working your way back. Evenly torque the exhaust clamps to 35 ft-lbs. Make sure that each slip is fully inserted (+/- 1/4 inch).

**Figure 5**

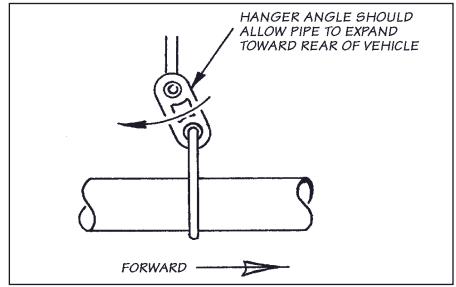

**14.** Your system includes two (2) Banks power logos. The logos can be mounted 1/2" to 1" above the "Cummins Turbo Diesel" emblem on the driver-side and passenger-side front fenders.

**15.** Re-connect the negative battery cable. Start the engine and listen for exhaust leaks. Tighten the exhaust clamps as necessary. Whenever possible, tack weld slip connections to prevent disengagement is recommended. The Banks Monster Exhaust installation is now complete.

**Figure 6**

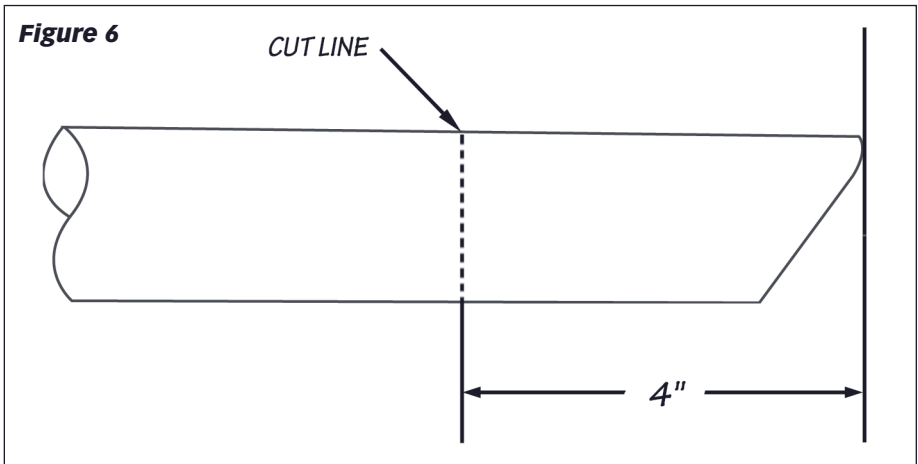

Gale Banks Engineering  
546 Duggan Avenue • Azusa, CA 91702  
(626) 969-9600 • Fax (626) 334-1743

Product Information & Sales: (888) 635-4565  
Customer Support: (888) 839-5600  
Installation Support: (888) 839-2700

**bankspower.com**