

F-300/500BAF

SELF-CONTAINED FLAKER WITH BUILT-IN STORAGE

Item # _____

Project: _____

Qty: _____

*AutoCad available on KCL

F-300/500BAF

I/13

Item # 13142

FLAKER DIMENSIONS W x D x H

F-300BAF
36 x 24 x 39*
*with 6" legs

F-500BAF
38 x 29 x 42*
*with 6" legs

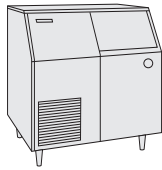

F-300BAF

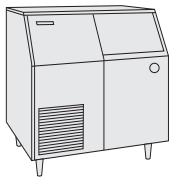

F-500BAF

F-300BAF

Air-Cooled

F-500BAF

Air-Cooled
Shown



F-300BAF

- Up to 303 lbs. of ice production per 24 hours
- Up to 110 lbs. built-in storage

F-500BAF

- Up to 501 lbs. of ice production per 24 hours
- Up to 250 lbs. built-in storage

F-300BAF & F-500BAF

- Designed for long life dependability
- Corrosion resistant stainless steel
- Automatic system flush when bin control is activated
- Gear motor protected from overload
- Removable air filter
- R-404A Refrigerant
- Scoop - Protected by H-GUARD Plus Antimicrobial Agent

* The F-300BAF and F-500BAF are ENERGY STAR qualified.



FLAKED ICE DIMENSIONS

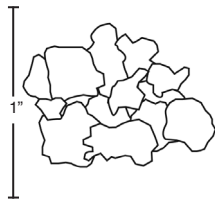

ISO9001-ISO14001

Warranty

Valid in United States, Canada, Puerto Rico, & U.S. Territories. Contact factory for warranty in other countries.

Three Year - Parts & Labor on entire machine. (Serial numbers Vxxxxxj and after.)

Five Year - Parts on: Compressor, air-cooled condenser coil.



Hoshizaki

SELF-CONTAINED FLAKER WITH BUILT-IN STORAGE BIN

DIMENSIONS

W x D x H

F-300BAF
36 x 24 x 39

F-500BAF
38 x 29 x 42
*with 6" legs

- Air-cooled
- Air-cooled

F-300BAF / AIR-COOLED

Water Temp ° F.	50°	70°	90°	
Air Temp ° F.	70°	303	290	278
	80°	267	256	246
	90°	236	232	218

F-500BAF / AIR-COOLED

Water Temp ° F.	50°	70°	90°	
Air Temp ° F.	70°	501	479	458
	80°	439	421	403
	90°	386	376	354

UTILITY CONSUMPTION

Model Number	Approximate Electric		KWH per 100 LBS.	
	90/70	70/50	90/70	70/50
F-300BAF	651W	613W	6.7	4.8
F-500BAF	902W	842W	5.69	4.03

SPECIFICATIONS

Model Number	Condenser	Amperage	Min. Circuit Ampacity	Shipping Weight
F-300BAF	Air-Cooled	9.0	N/A	210 lbs.
F-500BAF	Air-Cooled	9.98	20	270 lbs.

STORAGE BINS

Model Number	Application Capacity
F-300BAF	Built-in 110 lb. capacity
F-500BAF	Built-in 250 lb. capacity

- Circuit breaker or fuse protects gear motor from overload.
- Gear motor runs one minute after termination of ice making to clear all ice from evaporator.

***F-500 does not include power cord**

ELECTRICAL & PLUMBING/F-300/500BAF

- 115V/60/1
- 15 amp Max Fuse Size - F-300BAF
- 20 amp Max Fuse Size - F-500BAF
- 3/8" OD copper or equivalent independent potable water supply
- 3/4" FPT independent drain connection



ISO 9001-ISO 14001

© HOSHIZAKI AMERICA, INC.

618 Hwy. 74 S., Peachtree City, GA 30269

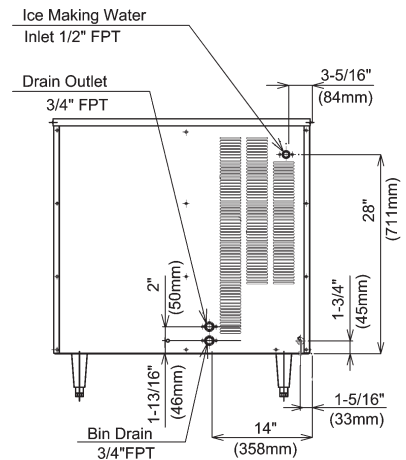
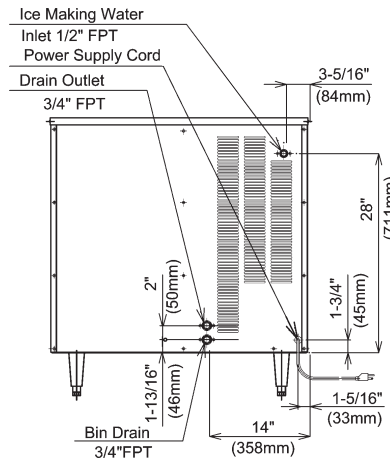
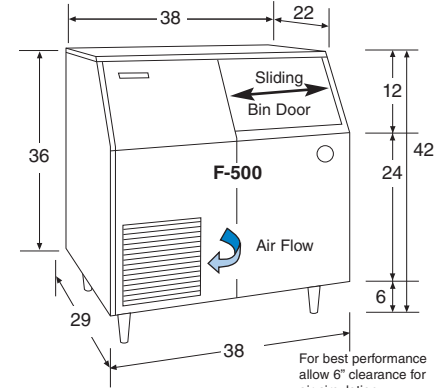
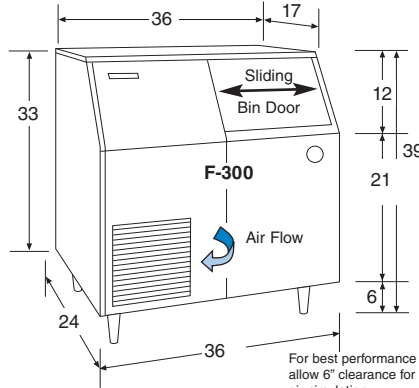

F-300 / BACK VIEW

F-500 / BACK VIEW

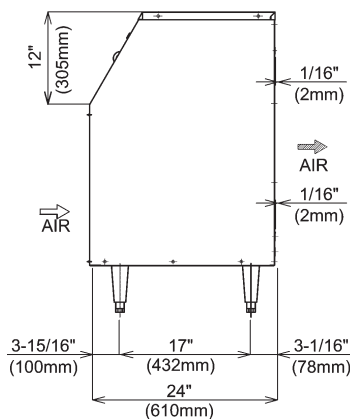

SIDE VIEW

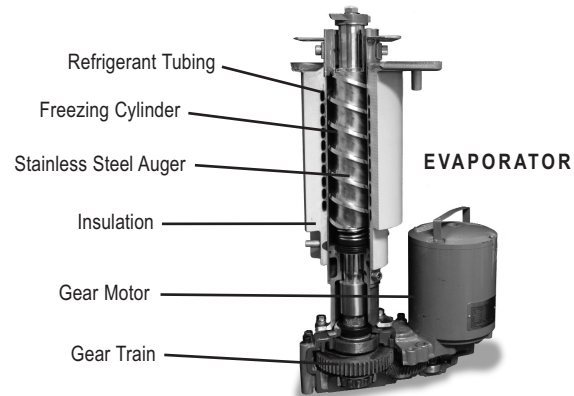

OPERATING LIMITS

- Ambient Temp Range 45 - 100°F
- Water Temp Range 45 - 90°F
- Water Pressure 10 - 113psig
- Voltage Range 104 - 127V

SERVICE

- Panels easily removed and all components accessible for service.
- Removable/cleanable air filters

