

THE
UNITED SERVICE
JOURNAL

AND

Naval and Military Magazine.

1831. PART II.

LONDON:
HENRY COLBURN AND RICHARD BENTLEY,
NEW BURLINGTON STREET.

WILLIAM BENTLEY

JOHN BENTLEY

1841

PRINTED BY SAMUEL BENTLEY,

LONDON:
PRINTED BY SAMUEL BENTLEY,
Dorset Street, Fleet Street.

1841

1841

1841

1841

1841

1841

CONTENTS

OF THE

SECOND PART OF 1831.

	PAGE
TACTICS, with reference to impending War	1
Song of a Peasant Girl after the Battle of Leipsic	23
On the Discipline of the Mercantile Marine	24
Survey of the West Coast of Africa in 1825-6	36, 185, 319
On the State of Efficiency of the British Army	43
On the Organization of the British Artillery, No. II.	47
Narrative of the late disastrous Voyage of the H. C. S. Bridgewater, 1829-30	49
Marshal Beresford—Battle of Salamanca	54
On condemning Smugglers to serve in the Fleet	57
The British Cavalry in the Peninsula	59
Yacht Clubs and Regattas	66
Lancers and Light Dragoons	69
The Drummond Light for illuminating Light-houses, &c.	77
Memoir of Field Marshal Count Von Diebitsch Sabalkanski	81
On the Mode of Arming and Fighting Steam Ships of War	89
Cigar-Smoking	91
Naval Reminiscences.—Dining out—an Adventure in Portugal	92
Reviews and Critical Notices	94, 234, 375, 537
On the Constitution and Practice of Courts Martial—Bourienne's Life of Napoleon—Education of the Sons of Officers	94
General Correspondence	98, 242, 393, 538
Military Superannuation and Widows' Fund	98
J. M. on Duelling, in Reply to his Critics	100
Capt. Cook and Sir Joseph Banks	102
Case of the Naval Architects	103
Yeomanry Cavalry	105
State of the British Artillery	106
Medical Department	107
A Grievance of Mates in the Navy	107
"Radical" and the Foot Guards	108
Contagion and Malaria in Cases of Fever	109
The Band of Gentlemen Pensioners	110
Proposition for a United Service Medical Society	111
The Editor's Portfolio	113, 257, 409, 553

	PAGE
Changes in the Stations of Corps	121, 268, 558
Arrivals, Sailings, and Incidents in the Fleet	122, 268, 429, 560
Prize Money	124, 560
Parliamentary Proceedings	125, 561
Promotions and Appointments	126, 277, 431, 569
Annals of the British Fleet	131, 572
Births, Marriages, and Deaths	142, 285, 438, 580
Meteorological Register	114, 288, 440, 584
To Readers and Correspondents	144, 288, 440
Naval Battles	145
Recollections of the late American War	162
On the Defence of Jersey	173
Reminiscences of a Subaltern	No. V. 177, No. VI. 328
Stand for a Mercurial Horizon	193
A Recent Visit to several of the Polynesian Islands	194, 473
On the Equipment of the British Infantry	202
Distribution of Light Cavalry and Infantry in the Field	205
The Veteran to his Sword	209
Yeomanry Cavalry	210
The Services of the late Admiral Sir Joseph Sidney Yorke, K.C.B.	215
The Services of the late Vice-Admiral the Right Hon. Sir William Johnstone Hope, G.C.B.	218
The Services of the late Rear-Admiral George Sayer, C.B.	221
Lithuania	223
Formation of a Naval and Military Museum	225
On the Distribution and Duties of the Unattached Medical Staff of the Army at Home	227
Reviews and Critical Notices.—On a New Armament for Ships of War, and Razéeing—Standard Novels—Cabinet Cyclopædia—Cabinet Library—The Twelve Nights—Views in the Burman Empire— Panorama of Constantinople—Family Classical Library—Hinton's United States—The Harmonicon—Cabinet Atlas—New Sporting Magazine—The Scientific Gazette—The Edinburgh Cabinet Li- brary—Haverhill; or Memoirs of an Officer in the Army of Wolfe	234
Experiments at Brest on Marshall's Gun-Carriages	242
Lord Camelford	245
Suggestion for a Cipher to be employed on Service	246
Remuneration for Shipwreck, &c.	247
Means of Preserving the Health of Soldiers	247
India Army—Tardy Promotion	250
Uniform of the Unattached	250
Deccan Prize Money	251
A Point of Etiquette	251
Remarks on the Proposition for a United Service Medical Society	251
Addresses and Orders on the 16th Regiment leaving Ceylon	252
Quere as to First Naval Engagement in the French War of 1744	253
Murder of Capt Logan, 57th Regiment	253

CONTENTS.

v

	PAGE
Courts-Martial	270, 568
General Orders, Circulars, &c.	271, 567
Annals of the British Army	280
Reform	289
Letters from Constantinople, No. I.	300
Theory of the Universe; comprising Strictures on Commander Wood- ley's "Divine System"	305
The Soldier's Bride	318
Singular Order of Lieut.-Gen. Prescott in 1794	338
The Services of the late Admiral the Right Hon. the Earl of Northesk, G.C.B. and Rear-Admiral of Great Britain	339
Remarks on the Comparative Services and Rewards of the several Branches of the Army	343
United Service Recreations at Portsmouth	349
Thoughts on the Systematic Practice of Naval Manœuvres	350
The Effects of Inexperience in Naval Affairs on the Part of the Army —with a Remedy	354
Actions of the British Cavalry	357, 522
The Services of the late Admiral Sir John Knight, K.C.B.	363
The Services of the late Vice-Admiral Viscount Torrington	365
The Niger	367
Observations on Naval Gunnery	369
Reviews and Critical Notices.—Colonel Napier's History of the War in the Peninsula, Vol. III.—Capt. Hall's Fragments of Voyages and Travels	375
Queries	391
Yeomany Cavalry	393
The Twenty-third Light Dragoons at Talavera	396
Yacht Clubs and Regattas	396
United Service School—Naval and Military Museum	398
Masters in the Navy	399
Mates in the Navy without Rank	399
Medical Department	400
Army Medical Department	401
State of the Royal Marines	402
The Corps of Gentlemen Pensioners	403
Suggestions on Drill	404
Commander Lawrence on Leather Storm Sails	405
Indian Army versus that of St. Helena	405
Trisection of an Angle	406
Stations of the Army on the 1st of July 1831	435
A Voice from the Army	441
On the Military Organization of Switzerland	453
Hints on Naval and Military Policy	455
On Naval Timher	457
Recollections of a Visit to Warsaw in 1828	467
Skirmish in Persia	483

	PAGE
Epitaph on the late Colour-Serjeant Robinson, 5th Regiment	487
Target Practice	488
The late Voyage of H.M.S. Chanticleer	489
Effects of Intemperance in the Fleet and Army—and its Remedy	497
An Improved Log-Ship	501
Chain Messengers	503
A Popular View of Fortification and Gunnery, No. IX.	505
The Thirty-fifth Regiment	512
Rifle Cartridges	513
Services of the late Capt. Sir Murray Maxwell, Knt. and C.B.	531
Plan of Illuminating the Semaphore Telegraph	535
Remarks on Lieut. Raper's Method of Working a Day's Work	536
Reviews and Critical Notices.—Life of Sir Thomas Lawrence.—Brooke's Travels in Spain and Morocco—Life and Adventures of Nathaniel Pearce—Fletcher's History of Poland—Classical Library—Epi- tome of English Literature—Cabinet Cyclopædia and Library— Cabinet Library—The Sunday Library—Sporting Magazine	537
Suggestion for preventing accidents by Steamers	538
Judge Johnson's Military Law	540
Comments on "The Distribution and Duties of the Medical Staff of the Army"	541
Comforts of Midshipmen Afloat	545
Charge of the 23rd Light Dragoons at Talavera	545
Suggestion for a United Service Retreat	546
The British Cavalry	548
Case of John Shipp, late 87th Regiment	548
Badge of Merit	549
Abstract of Officers who served in the Army on the Peninsula and at Waterloo	550
The "Micee" of Hindostan	552
Military Punishments	552
Staff Changes and Alterations—1830	558

 ERRATA. 1831, PART I.

Page 435, lines 19 and 20 from the bottom. There should not be a full stop or new paragraph, the sentence should run on from the quotation.

In the Yeomanry Paper, page 500, line 12 from the bottom, for "pretty well" read "fitted well."

Ditto page 502, line 21 from the bottom, for "position" read "formation."

Ditto page 502, line 18 from the bottom, for "their" read "this."

Ditto page 504, line 3 from the top, for "horse" read "hour."

Ditto page 505, line 10 from the bottom, for "first rank" read "front rank."

Ditto page 505, lines 23 and 26 from the top, for "division" read "divisions."

ERRATA. 1831, PART II.

Page 6, line 34 from top, for "second battalion" read "two battalions."

Page 9, line 25 from top, for "by mere pressure" read "by the mere pressure."

Page 70, line 10 from bottom, for "Druidar's" read "Dundas's."

Page 339, line 3 from bottom, for "20th of January" read "21st of January."

Page 304, line 7 from bottom, for "Lucca" read "Queen."

Page 364, line 12 from bottom, for "1799" read "1797."

Page 365, line 12 from bottom, for "Warmer" read "Wallace."

Page 366, line 23 from bottom, for "Schweling" read "Scheveling."

In our report of the Library and Museum Meeting, for "Capt. Blackhouse, R.N." read "Capt. Backhouse, Unattached."

THE
UNITED SERVICE JOURNAL,
AND
NAVAL AND MILITARY MAGAZINE.

TACTICS.

WITH REFERENCE TO IMPENDING WAR.

“ C’était de tous les arts le plus funeste, mais
Celui qu’il fallait le plus perfectionner.”—VOLTAIRE.

THE peace which had been purchased for liberated Europe by so much blood and treasure, is again drawing to a close. A factious press, conducted by ignorant and designing men, more frequently than misguided enthusiasts, has at last succeeded in calling forth the fierce and destroying spirit of Democracy,

“ Whose wild incessant cravings spur
From crime to crime its worshipper,”

and has at the same time, as a necessary consequence, infused fresh vigour into that antiquated absolutism which was gradually giving way before the increasing light and wisdom of the age, but which is now roused to fury by the necessity of self-defence. Continental Europe is thus divided between two hostile principles, that, like Milton’s fiends, on the verge of battle, frown on each other

“ ————— As when two black clouds
With Heaven’s artillery fraught, come rattling on
Over the Caspian, then stand front to front
Hovering a space, till winds the signal blow
To join their dark encounter in mid air.”

In such a state of affairs the sword alone can be leaned upon with safety; for though our own shores may not be immediately assailed, yet it will become our duty to protect Europe, and the cause of freedom and civilization, from the ruin that must follow any decisive victory gained by either of the contending parties. We must be alike prepared to say to autocrats or demagogues, “ Thus far shall ye go, and no farther:” and this is what we can say by the aid of arms alone. But as we can do this with confidence, whenever our military policy and method of war shall do justice to the power and the energy of our people, it may not, under such circumstances, be amiss to institute some inquiry into the efficiency of the system of war on which such mighty interests will soon be staked. And as the only mode of conducting such an inquiry is to “ begin at the beginning,” we shall for the present leave military policy and organization entirely out of the question, and merely ask in the plain and soldier-like language, best befitting the subject,

and without any attempt to gain by sophistry or evasion a victory of words, but with the honest view of arriving at just professional principles,—what is the object of Tactics, and how far does the modern science of Tactics attain its object, and do justice to the character and energy of the people of these islands?

That the object of tactics is to arm, train, and instruct the soldier in such a manner as to render him, when contending against the enemy, as formidable an engine of destruction as is compatible with poor human nature, will probably be allowed on all hands; so that we have at present only to inquire how far that object is attained. We shall first confine ourselves to the infantry, not only because it is the principal arm, and must always constitute the main strength of armies, but because cavalry tactics are in principle less faulty; so that the weakness of that force has been owing less to its constitution than to the manner in which it has been understood and used; whereas the strength of the infantry, such as it is, has resulted from causes over which tactics had no control, but which not being understood by tacticians, have led them into a belief of the wonder-working powers of their boasted science; and has thus tended to keep up a system of delusion that has cost the country millions of treasure and thousands of valuable lives.

The modern science of tactics teaches the soldier his position under arms, his facings and marching; and it enables a commander to give to any number of men a uniform and simultaneous impulse and movement. But it contributes in nothing to develope or increase the personal strength, energy, and activity of the soldier, from whom, of all men, the most active of exertions are demanded; and not only may its exclusive use of the musket and bayonet be questioned, but it does not even instruct the soldier in the skilful use of those arms, and leaves him consequently destitute of that confidence in his mode of fighting which is always the surest forerunner of victory. Our present system of tactics is, in point of principle and with few variations in detail, exactly what Prince Leopold of Dessau introduced into the Prussian army about a century ago; it teaches men to act together, and is very well as far as that goes; but it is still far behind the Roman system, which not only taught men to act together, but to act boldly and energetically: that system which led to the conquest of the known world, developed in men of rather small stature a degree of personal strength that enabled them to perform marches, and to construct works, that astonish us even at this day, and rendered them above all, so confident and skilful in the use of arms, that they never met their match in equal combat. And why do we remain so far behind the Romans? Is a musket an easier weapon to wield than a sword or a hasta? Are modern soldiers taken from a class of men more inured to athletic exercises than the ancients? Or are the toils and difficulties of modern war inferior to those the ancients had to contend with? Verily I should think not. The cause of our inferiority must, therefore, be sought for in the opinion entertained by tacticians of the excellence of their art; for no mere acknowledgment of its difficulties could have kept it stationary for such a length of time. Let us try that boasted excellence therefore, and see what are the destructive powers possessed by an art whose object is destruction itself. They will probably be found less formidable than might at first be suspected.

Supposing that 20,000 French were killed and wounded at Waterloo, and allowing 5000 of these to have fallen by the fire of the artillery and the sabres of the cavalry, it leaves 15,000 to the share of the infantry; and counting the latter at 30,000 only, though the number present was certainly greater, it required an entire day's hard fighting before the 30,000 had disabled 15,000 adversaries: that is, all the exertion of two men during an entire day only brought down one enemy!!! Let not the reader here think of two fencers who by equal skill and courage foil each other's exertions; there is no such thing as parrying a musket-ball when properly aimed, nor is there any defensive power in modern armies beyond what they derive from their offensive strength; for with modern arms all fighting is purely offensive. The above estimate of the efficiency of modern tactics may, indeed, be considered as highly overrated, because it applies only to the most sanguinary battles fought during the war, such as that of Marengo, Talavera, Borodino, and others, but by no means to actions of minor note: at Roliça only a few hundred French were put *hors-de-combat*, and at Vimiera 16,000 British only killed and wounded 2000 French, after what was called a smart action.

Now, we are allowed on all hands to be more able-bodied men than the French, and illiberal as it may sound in these liberal days, we are also individually a far more active and resolute people. The army that fought at Vimiera was composed of as fine men as ever left England, so that we may take it for granted that they were, on an average, superior to the men of the French army. Let us suppose then for a moment, that both parties bad, by mutual consent, divested themselves of their arms and tactics, and fairly fought it out with no other aid but their natural strength and courage, does it not follow, as a matter of course, that the 16,000 stronger must have so pounded the 14,000 weaker men, as to have rendered the latter totally incapable of impeding the progress of the former towards Lisbon. If so, tactics, instead of strengthening the strong in proportion to their strength, must be something that principally favours the weak; an exceeding good reason, one would think, why the strong should look twice at the system before they adopt and follow it with blind adoration. That it has made us victorious, proves in itself nothing until it is shown that the success was the most decisive, and attended with the least possible loss; but twenty-five years of dubious war, the convention of Cintra, and the lists of killed and wounded that were at times not much inferior to those of the vanquished enemy, form a sufficient quietus to all speculations upon those points. Achilles would have been formidable even with the arms of Thersites, but it was only in the Vulcanian arms suited to his strength and power, that the Goddess-born became invulnerable and invincible: it is even thus with British soldiers; they are as formidable as men can be with the present system of tactics, but it is only by a system capable of doing justice to their energy and resolution, that, like Pelides rising in his strength, their full power of action can be displayed.

“ Throw your plaids,
 Draw your blades,
 Every man to set;
 Pybroch of Donald Dhu
 Now for the onset.”—SIR W. SCOTT.

Having seen what is the destructive, or as political economists would say, productive power, possessed by modern infantry, when contending against those who are about their equals in point of science, let us next see what they can effect when opposed to men who have followed a more energetic mode of action, or when contending against those who, by accident or design, have evaded the only strong point of modern tactics, and struck at one of its ninety-nine weak sides. The result will not be very flattering to the “ King making ” science.

At Prestonpans, 2000 highlanders, armed only with broad swords and targets, overthrew at the very first onset nearly 3000 British infantry, and completed their defeat in about a quarter of an hour: the same was the case at Falkirk: and even at Culloden every point of the line that the highlanders reached in their charge was completely overthrown. As we may be told that the infantry of 1745 was not equal to that of the present day, and as any person making such an objection could probably not point out the difference, we shall ourselves show in what it consisted. The infantry in 1745 could neither move nor form with the rapidity of modern infantry; they used wooden ramrods, that during a quick and protracted fire were liable to break; and they fought three deep as all continental armies do to this day; but in every other respect they were trained on the same principles, and fought exactly in the same manner that we do now; nor did the defeats above stated result from the wooden ramrods or from any tardiness of movement, for the King's troops were all drawn up and formed when assailed by the highlanders, and a charge could leave no time for more than one or two volleys. Though lowlanders, we are proud of having worn the tartan, and we love the mountaineers, but we cannot claim for them any superiority of personal courage over the English; for as yet no men of women born can make such a claim, nor are they in general considered equal to the Southerons in point of strength; and as generalship was entirely out of the question in these front to front onsets, their victories must be solely attributed to their superior and more energetic mode of fighting, and to the skilful use of a more efficient weapon.

That the King's troops were ultimately victorious at Culloden, proves nothing in favour of their tactics; for not only were they vastly superior in number, but they were aided by a succession of faults on the part of the highlanders that sets all speculation utterly at defiance. The latter had made a long and fatiguing night-march towards Nairn and back again; they had been without food on the previous day, and were without provisions on the morning of the battle; they had neither cavalry nor artillery worth noticing; and though their retreat was perfectly open, though there were strong positions all around, and reinforcements on the march to join them, they yet drew up on the open heath of Culloden to fight an enemy nearly double their number, (=9 : 5) and well provided with both cavalry and artillery. Where is the strategus, who, with the best drilled soldiers to back the pride of

modern science, would, on level ground, have ventured to engage the overwhelming superiority of regular troops, that these poor highlanders here so fearlessly encountered, and whom their good claymores would perhaps have overcome, had the leaders been at all worthy of the men. But, as if the faults that led to the battle had not of themselves been sufficient to ensure defeat, the battle itself completed the measure of all imaginable follies; for the clans, instead of making immediate use of their own formidable and only mode of fighting, remained for upwards of an hour perfectly inactive under the heavy and discouraging fire of the King's artillery; and when, after sustaining a heavy loss, they did advance, the charge was but partially made even by the first line, the second and third taking no share whatever in the action, and leaving those of their comrades who had been successful entirely unsupported. The Prince too, with the feebleness of spirit that distinguished him, and which was so ill-suited to his enterprise, remained perfectly inactive, forgetting that the second line is no place for him who would win a crown at sword's point. Had he known how to do justice to the qualities of his followers, and had he, as in duty bound, led the charge sword-in-hand, not a man of his army would have remained behind, and, independently of the chances of victory such conduct would have given him, the battle, if lost, would have been lost with honour, and the loss such a contest must have inflicted on the King's troops would at least have put all serious pursuit out of the question.

The idea of conquering England, before whose strength the mightiest of the earth have fallen, at the head of a few thousand of half armed mountaineers, seems now something more than ridiculous: and yet it is really difficult to say what the result might have been if the highlanders had followed up the victory of Falkirk with vigour and celerity. Their army was then at its greatest height in point of numbers, they were elated with success, and their enemies depressed by constant defeat: neither the Scotch lowlanders nor the people of England took any active share in the contest, and the Irish rather favoured the Adventurer: a rapid return into England at the head of a more numerous and victorious army, would have dismayed the adherents of the house of Hanover, and inspired the partisans of the old dynasty with a degree of confidence, which the previous unsupported advance and quick retreat from Derby could not call forth, so that the invaders would have had every thing in their favour, and the English army only to contend with. That army was not numerous; it was probably as indifferent to the cause as the rest of the nation; there was no leader capable of inspiring it with enthusiasm, and worse than all, it had been defeated in every encounter, and in a manner too that could not fail to convince both parties of the decided superiority of the highland mode of fighting. The mountaineers indeed were in the highest degree confident, and feared no odds whatever: and men whose confidence results not from mere vanity, nor from an ignorant undervaluing of their enemies, but from a just appreciation of their own daring and energetic mode of warfare, may be considered, when justice is done to them, as pretty nearly invincible. Had a man like Charles XII. led such soldiers, he would have fought the battle for the crown of England, not at Culloden but on Hounslow Heath, where in the person of George II.

he would, *hand to hand perhaps*, have encountered no unworthy competitor. But Charles Edward was unequal to such an undertaking; he retired when he should have advanced, forsook the cause on the first turn of fortune, and abandoned his devoted followers, without even offering his own worthless life in ransom for their blood, to the savage cruelty of a conqueror, whose defeats were less disgraceful than his triumph, whose brows victory crowned with asphodels instead of laurel, and whose name will be handed down to posterity as the exterminator of an erring and misguided race, distinguished for a degree of gallantry and of devoted attachment to their ancient line of kings, that would have ensured for them the generous forgiveness and admiration of all who had either the head to appreciate or the heart to feel the value of such rare and noble qualities.

Trusting to the reader's indulgence for this short digression, we return to the thread of our subject, and proceed to bring forward other proofs of the weakness of modern infantry, as by tactics established.

It is well known that till within these few years the Russians never ventured, unless when covered by *chevaux-de-frise*,* to await the sword-in-hand onsets of the Turks. As soon as the turbaned warriors had been brought up by the iron spikes of the firm-footed Friezelanders, and had inhaled a little sobriety from the well-plied muskets ranged behind, then the victory was complete, the Faithful went to the right about, and leaving tents, guns, Pashas, and Viziers alike in the lurch, every man betook himself, for that year at least, to his own home. If on the other hand they broke in among the forefinger tacticians, which but for the *chevaux-de-frise* could hardly fail to happen, then the scymetar raged quick, fierce, and masterly, till checked only by the want of victims, or by the excess of the very fury that brought it into action.

In the war of 1778 two scenes of this kind took place near Chotzin, in the first of which three Russian regiments were completely destroyed before they could be supported, though forming one of the centre squares of the army; and in the second, the second battalion of the grenadiers of St. Petersburg were cut up to a man by a similar sword-in-hand onset, and with a degree of celerity that was not the least astonishing part of the whole transaction. We are indebted for a knowledge of these facts to the memoirs of Prussian officers sent on one or two occasions by Frederick II. to accompany the Russian armies: for the Russians themselves never mentioned these "untoward events," a sufficient reason perhaps for our not having a longer list of them, as the Turks, to whom the trouble of fighting was enough, never wrote bulletins till they lately took up the science as part of the European system of tactics; forgetting, unfortunately, that a good blow of a scymetar is worth at least nine-tenths of *la grande science*. It was during the same war that the celebrated Hassan Pascha raised the siege of

* For the manner in which the *chevaux-de-frise* were carried, put together, and actually *manœuvred*, see Manstein's Memoirs; for the Russians, with characteristic ingratitude, never mentioned the services of these useful allies. As to the general fact that most of the Russian and Austrian victories were owing, not to their tactics, but to their *chevaux-de-frise*, it may be gathered even from the writings of our own countrymen Bruce and Crawford.

the castle of Lemnos in such a gallant manner. He crossed over from the Troad in open boats during the night, and landed on a retired part of the island with only 1500 men, few of whom had even pistols in addition to their swords. Having set his skiffs adrift, he told his followers that victory was their only resource, and immediately led them against the well-disciplined Russians, men who had fought with success against the armies of Frederick himself; but who were here so completely routed by the superior courage and energetic mode of fighting of a handful of desperadoes, that those who escaped the scymetar, owed their safety less to tactics and science, than to the speed of their ignominious flight, and the vicinity of the boats of their fleet consisting of seven sail of the line besides transports and other vessels.

The affair of Dubitza is still more striking, and is thus related in Bushen's Memorabilia (Merkwürdigen Welthändel) of modern times: "A breach in the strong rampart that forms the only defence of Dubitza having been effected, the assault was attempted. But the Turks, making at the same moment a sortie, and also forcing their way sword-in-hand through the breach, inflicted so heavy a loss on the Imperial army, that the latter, owing also to the appearance of another party of Turks who showed themselves at a distance, were forced to raise the siege and retire from before the place. The history of Polybius records the only other instance of similar daring to be met with in the annals of war." What Marshal Lascy says of the Turks and their mode of fighting, is too much to the purpose to be here passed over. "The Turks," says he, "are proud, most of them are also personally brave, and their very principles (grundsätze) make them hate their enemies. From this it results, that the actions fought against them are generally very sharp; their great skill consists in the dexterous use of the sword, so that whenever they are successful they invariably kill and wound a vast number of men." Against such a mode of fighting, the Field Marshal, himself one of the founders of the present school of tactics, knows no remedy but to cover his battalions with *chevaux-de-frise*. It is only behind the iron spikes of these faithful allies that cuirassiers and bayoneteers, the pink and pride of modern tactics, are deemed safe from the simple scymetars of the bold and the resolute. Might not the Marshal's own words serve as a funeral oration for his science; and can its utter insufficiency be more strongly illustrated.

That the Turks have of late years been constantly the losers in their wars against the Christian powers, has been owing less to their want of tactics, than to their want of organization, method, and subordination: without these all other military qualities are, in the present systematic mode of warfare, perfectly unavailing, and of these the Moslems have been totally destitute. Had they combined these qualities with their former mode of fighting, and known its full value and efficiency, the late bold *coup-de-pointe* across the Balkan, would probably have been paid for in Russian heads in place of Turkish piasters; for, as far as we can make out, it was an enterprize founded upon no strategical principles whatever: but was merely risking an army, in the real Napoleon style, on the chance of events that fortune might bring about, but which the strength of the invaders could not effectuate. It proved successful; for war, like all other lotteries, has its prizes, whose glittering rewards offer tempting inducement to the leaders, though unfor-

tunately the poor soldiers invariably pay the forfeiture of the blanks that in such mere games of chance follow pretty close behind.

To the instances above quoted one of a later date must be added, because it is only by being made to pay for the impressive lessons of experience, that our vanity allows us to profit by them. After the first expedition to the Persian gulf, 500 sepoys, trained and instructed in the European manner and commanded by English officers, were left behind in order to check the marauding propensities of some of the native tribes. This detachment was attacked by a party of Arabs, who sword-in-hand rushed upon them in the real Turkish and highland style, and cut them down almost to a man. We appeal to the officers of the 65th regiment, who were subsequently sent to avenge this insult, whether that gallant corps ever witnessed a more precarious contest than that in which they were engaged with the tribe of Ben-Ali: let them say what the result would have been, if the Arabs, who were far inferior in numbers to the total of the British force, had, instead of opening out from the fire of the 65th regiment, borne straight down upon them, or had been so judiciously led as to arrive unawares on the British line, in the manner in which they came upon the picquets the night after the landing.

But how, it may be asked, does it happen that soldiers regularly trained to war should be inferior to men who have nothing but native daring in their favour? Simply because there is nothing energetic in modern tactics: the men have no skill in the use of the clumsy arm placed in their hands; they are not trained to individual exertion; have, consequently, no confidence in their individual power, and only look to the mass for results; an error amply shared by all modern tacticians, who entirely forget that a mass of men has strength and value only in proportion to the strength of the individuals composing it. Nothing is so easy, therefore, as to account on just principles for the overthrow of the infantry in the cases above cited. We have seen by comparing the number of killed and wounded in modern battles with the number of combatants, that it requires, on an average, more than a day's exertion to enable an infantry soldier to put an enemy *hors-de-combat*; or we may say, that it requires 100* musket-shots to produce that effect. At all events the duration of a modern action, and the numbers engaged when compared with the execution done, amply prove how slowly regular infantry perform their work of destruction. On the other hand, men who fight as the Turks and highlanders once fought, perform their work of destruction in a very expeditious manner: they can hardly be exposed during more than a minute to the fire of their enemies; for 250 or 300 yards is the greatest efficient range of musketry-fire, and this is a distance that active men will easily traverse in about a minute without suffering much loss, we may presume, from those who, as we have seen, require a day each before they bring down an adversary. And when they close, what can modern infantry oppose to the bold and spirit-stirring onset of enemies, skilful in the use of an arm whose every blow tells, and whose blows are dealt with a rapidity that soon puts all idea of priming and loading out of the question?

* By some calculations no less than 200 shots are required. We take 100 as the lowest estimate we have seen.

Their bayonets, perhaps,—“*risum teneatis amici!*” Let any one hold up at arm's length a musket and a bayonet, feel its weight and handiness, and look at its form; he will first see the thick and clumsy butt bending downwards, then the straight line of the barrel with its heavy lock, next the arm of the bayonet standing off at a right angle, and, lastly, the shaking blade itself again slanting away to the right; the entire of the rickety zig-zag instrument measuring from butt to point six feet two inches, projecting, at the position of the charge, about three feet and a half from the soldier's person, and weighing twelve pounds; and this is the sort of thing with which soldiers, totally untrained to its use as an arm of personal combat, are expected to oppose the sword, the handiest and most efficient weapon ever put into the destroying hand of man; and the very wave of which acts as an electrifying power on the spirit of the brave.

The bayonet may in full truth be termed the grand mystifier of modern tactics. Musket-balls have brought thousands and thousands of men to the ground, because hundreds of thousands of shots are fired on every occasion; round and grape have also helped to irrigate the thirsty earth with the blood of her children; the sabres of the cavalry have occasionally dealt efficient blows, and the spears of the lancers may at times have overtaken some wretched fugitives, who had not sufficient courage to face even so paltry an arm; but the bayonet shines in virgin brightness, hailed as the victor of every field, and yet undimmed by the blood of *fighting* men: it is the arm, *par excellence*, of an age whose power of intellect wins battles by mere pressure of a fore-finger and by the bloodless display of this Mesmerian arm, before which the heads of the mighty are bowed to the dust, and the backs of the fierce turned to hasty and ignominious flight.

That men have fled before our bayonet proves nothing. The science of tactics, rendered necessary in order to curb the evil propensities of mankind, can rest with safety on the sad and melancholy power of destruction alone. The effect produced on the imagination can never be relied upon, because the effect produced one day may not follow on the next: the French cavalry generally stood the charge of the British; why then should the infantry always be expected to run away? and what would have been the consequence if in some of the headlong attacks made by British infantry upon vastly superior numbers, they had come against foes provided with efficient arms, well-skilled in their use, and closing as boldly as the French cavalry generally did? If by good fortune this has not yet happened, it may happen, and should, therefore, be provided against; for military history is little more than a succession of delusions that disasters have alone dispelled.

Having seen how far tactics and training qualify the soldier for close fighting, let us next see how he gets on in distant and other occasional modes of combat.

After the unfortunate attack on Rosetta in 1807, three companies of the 78th and some other detachments, whilst attempting to effect their retreat to Alexandria, were defeated and taken by a party of Albanians, who surrounded them, and kept them constantly at long shots, without ever attempting to come to close quarters: it was, on a small scale, an exact renewal of the defeat of Crassus and his legions, without the Roman skill in hand-to-hand combat, could the action have been

brought to that issue. The Albanians, owing to the wretched construction of their long and unwieldy muskets, and to the badness of their ammunition, their balls being invariably cut or hammered into any shape but a round one, are well known to be even worse shots than the trained soldiers of Europe, and their only mode of fighting consists, like that of the Parthians, in keeping their enemies at a distance. Yet before such men was a strong detachment of the proved soldiers of England forced to lay down their arms! Totally unskilled in any mode of individual contest, they sought shelter only in a square, and thus presented an almost infallible mark to the aim of their unskilful enemies: their own fire being at the same time too inefficient to make any impression on their scattered foes, who, it is well known, would not have remained in the open field exposed to much danger; for the Greek revolution war, the heroic struggle *par excellence*, offers no instance of a Greek or Albanian force ever risking the loss of even fifty men in the open plain as long as the means of flight were in their power. That the Albanians far out-numbered our troops on this occasion is very true, but it is the object of tactics to render the few capable of contending against the many.

Several of the actions, or skirmishes rather, fought during our last American war in Upper Canada, furnish ample proof of the disadvantage under which mere tactical soldiers fight when contending against men who, however inferior in every essential military quality, happen to be individually superior in the use of arms. Owing to our firmness and discipline, we were generally victorious in those actions; but as the actual fighting took place with arms in the use of which we were far, and needlessly inferior, our success was always attended with a greater proportionate loss than what we suffered when contending against the disciplined armies of Europe: a loss much greater too than what should have been experienced from enemies who, however brave and superior in point of numbers, were yet far from being our equals as soldiers.

One of the actions of this ill-conducted war* is too strikingly illustrative of the effects of tactical training to be here omitted.

An American army, that in European warfare would have been called a corps, was surprised by the 49th and 89th regiments, at a place called Stoney Creek. The attack was made by night; the sentinels were cut down before they could give the alarm, and so well was every part of the onset conducted, that the enemy were literally found fast asleep in their tents and bivouacs: the victory was actually gained before a single man had been lost. But the evil genius of modern tactics,

“ That pagod thing of sabre sway,
With front of brass and feet of clay,”

grants no bloodless victories, and was not to be defrauded by either party of its usual share of slaughter: the men, totally unused to the bayonet as an arm of personal contest, began to fire; the Americans sprang to their arms, a desultory night-action commenced in the woods, all the advantages of the surprise were completely frustrated, and the

* Ill-conducted by the English and Canadian Governments. The defence of the immense frontier of Canada by a few weak battalions and untrained provincials, reflects the highest credit on the actual defenders.

British, though as usual victorious, lost by friends and foes, nearly as many men as their defeated adversaries.

The skill of the Americans in the use of the rifle was very conspicuous during the late war, and, as brave men, they naturally made the most of the advantage. But the tales of wonder related of that skill, prove how ignorant men generally are of the real power of fire arms; for no arms ever constructed by human hands could, if fixed and levelled with mathematical precision, come within fifty degrees of what is told of every Kentucky rifle. Nothing can give a more striking proof of this than the fact, that in all the actions fought on open ground, where the fire of both parties could tell, the fire of the common English shots invariably produced a greater effect than that of the most skilful Americans. This assertion is not to be turned against us; for it must be recollected, that owing to the many advantages we possessed over the Americans, we should, in spite of their superior numbers, have inflicted a heavy loss on them with little risk to ourselves, had we been at all their equals in the use of arms.

In both our wars with America we have suffered from their superior skill with the rifle, not so as to influence ultimate results certainly; for ill as those wars were conducted on our part, it was only a factious press and opposition that forced the Government to make peace when success was actually within their grasp; but the fall of every soldier who is lost owing to the superior skill of the enemy in the use of arms, is a reproach to the system under which he is trained, and which leaves him inferior to those against whom he is called upon to contend. It is a double reproach upon us, because Englishmen are particularly apt at learning all military and athletic exercises: and there is certainly no witchcraft in good rifle or musket shooting; it is an art that all men of ordinary nerve and powers of vision may easily acquire, but as our soldiers are not like the back-woodmen of America, and the foresters of Germany, trained to the practice from infancy, good instruction must make up for that disadvantage; but the present mode of drill only tends to make men bad shots, as Fromm, in his "Direction for the Instruction of the Infantry in the use of fire-arms," very clearly proves. We have as yet derived no benefit from the experience so dearly purchased in those two wars; and were we again called upon to take the field in Canada, our soldiers would be individually found just as unfit for that peculiar warfare as ever.

" The charge once made no warrior turn the rein,
But fight or fall a firm embody'd train.—*Iliad*, Book iv.

There is another, and to us a very important point of view in which the insufficiency of modern tactics must be considered: and that is the helpless condition in which it will always leave the infantry when exposed in the open field to the attacks of cavalry who shall know and do their duty. Many will no doubt term this perfect heresy, and refer the writer to the Book of Regulations for the various pretty and ingenious modes of forming squares, and to the events of the last war as ample proofs of their efficiency. The Book of Regulations we honour to the full extent of its value, but are not disposed to take it for two-

thirds more than its worth. A complete system of tactics, as complete as such a science can be, must commence by a mode of training capable of developing all the strength and activity the recruit may possess: it should then instruct the soldier in formation, movement, and the simultaneous power of action: and lastly, it should render him skilful in the use of arms. Of these three parts of such a system, we have as yet the second part only; so that a reference to the book had better be delayed till the first and last chapters are added to the volume.

But the events of last war, it may be said, amply establish the efficiency of infantry squares. The events of last war, when duly considered, only prove that the general failure of the cavalry, which we admit, has, instead of leading to a due investigation of the causes of such failure, tended, on the contrary, to disseminate and foster one of the most palpable, and to us, who from our insular situation must generally be weak in cavalry, one of the most dangerous delusions that ever yet perverted military vision. The proofs of the assertion are not difficult to find.*

Supposing a body of cavalry to charge a square of infantry, to do their duty and not to open out from the fire of the infantry as is generally the case, one of three things must follow as a matter of course,—either they must fall by the fire of the musketry, be arrested by the bayonets, or they must, dead or alive overthrow the opposing ranks of the infantry. Now without again reverting to the number of musket-shots that tell, we know very well that, to the utter astonishment of many officers present, entire volleys were fired at Waterloo and at Fuente de Guinaldo, without apparently bringing down a man, however many might have been hit. We also know that not a single one of the enemy's horsemen perished on the bayonets of the kneeling rank in either of these actions: and it is of course perfectly evident that a horse at full speed, even if killed by the projecting bayonets, which is possible though not probable, would still by his very impulse overthrow all the files opposed to him; and thus make an opening for those who followed. In the present state of military training and opinion, the infantry could offer little or no resistance, when once broken, because their crowded formation would not only prevent them from evading the shock of the horses, but render it impossible for them to use their arms, even if they possessed any skill or confidence in such a close mode of fighting. At Albuera, a splendid brigade of British infantry was destroyed by the French cavalry without offering any effectual resistance with the bayonets: and on the retreat from Madrid, twelve of the 23rd Fusileers allowed themselves to be taken by five French Dragoons, without so much as pulling a trigger or presenting a bayonet, because they were conscious of possessing no skill in the use of arms, and had never been led to look for safety from individual exertion against cavalry. As squares only fight, at the option of the enemy, a quarter of the number of their men; and as the front of cavalry is as three to two, (thirty-four to twenty-two) to that of the infantry; thirty

* Count Bismark, in his *Cavalry Tactics*, also says, that when cavalry are *determined*, they must prevail over infantry. His translator, Major Beamish, takes a different view, and in a clever note, to which we refer those who take an interest in the subject, combats the Count's opinion.

horsemen two deep, might, with about equal front, assail any face of a square consisting of 400 men. Coming on at full speed, they could be exposed to one volley only, that is, to the effects and chances of *one hundred* musket-balls; of these not many would hit, still fewer would hit the men, and the horses that were not actually brought down would not complain, but go on till arrested by the riders. So that if the latter did their duty, a feeble half squadron of thirty men would have a fair chance of breaking a moderate battalion of infantry; for surely no one can well maintain with ordinary gravity, that the bayonets of the kneeling ranks form a barrier capable of arresting by its consistency a body of determined horsemen arriving at full speed against them, so that whatever might be the loss of the leading assailants, the boasted formation would at least be thrown open, and the crowded and helpless mass of defenders exposed without any means of resistance to the hoofs and sabres of the succeeding centaurs. There is hardly an opinion, connected with tactics, in favour of which more evidence might be obtained than the supposed heresy here advanced. We appeal to the officers who were present in those unshaken squares, that foiled so many charges of French cavalry during the long and arduous day of Waterloo: let them divest themselves of the received opinion on this subject, and frankly say, what would, nay what must have been the result, if the French horsemen, instead of constantly opening out from the fire of the British infantry, had stood with loosened rein and "spur of fire" right down upon their close and compact formation? must not the whole have been completely overthrown? Let it not be supposed, that there is any thing derogatory to their gallantry in this assumption. On the contrary, the greater and more evident the danger, the greater was the honour of manfully facing it at duty's call.

Hitherto the cavalry have failed, (though there are brilliant exceptions,) from want of confidence in their own prowess; they did not expect to succeed, and generally edged away to the right or left, and often, after receiving the fire from the point attacked, and when the principal danger was over, exposed themselves to greater loss from the fire of the other faces of the square, than they would have sustained had they rushed holdly on as a proper knowledge of their duty should have taught them; for nothing is more true than what is stated in the old Regulations, "the spur as much as the sword tends to upset an opposing enemy." The conduct of the French cavalry at Waterloo, in galloping round the squares to look for an opening, instead of attempting to force one, was, notwithstanding the praise bestowed upon it, a proof of professional ignorance or insufficiency of courage; for there is a sort of three-quarter courage, if we may so graduate it, that will gallop up to the bayonet, and even bravado round the squares, and yet wants the resolution to dash, at less ultimate risk, perhaps, into the midst of levelled muskets and presented bayonets; but those who cannot set an example of such resolution have no business on horseback, for daring is the soul of cavalry; and what is, after all, the single

* We are speaking of the squares most exposed to the ill-combined and worse directed attacks of the French cavalry; and are not at present giving any opinion as to the result of battle. Waterloo deserves a section of itself.

wretched volley of musketry, fired from the face of the infantry square, compared to what the infantry are exposed to in assailing a breach, St. Sebastian, for instance, or other post of difficult access? Opinion has rendered infantry squares formidable, and, whilst that opinion remains, they may continue so; but formidable as the arm of opinion is, it is not of a texture on which to rest a system of tactics.

The Marquis of Londonderry, in his History of the Peninsular War, in speaking of an action fought near Almeida, says, that some soreness was felt at head-quarters in consequence of the defeat of six squadrons of British cavalry by about 200 French infantry, though, as he asserts, some of the horsemen did not turn till the "bridles touched the bayonets." Why the men turned at the very time when the danger was over, and when they should have given spur and rein, the noble Marquis, though as brave a soldier as ever drew sword, does not tell us, nor do we recollect any order issued by the Adjutant-General of the Peninsular army, reproving the cavalry for edging-off, or instructing them how to act in similar circumstances for the future. But most of us may well guess in what thundering terms the "sore feelings" of head-quarters would have been expressed, if a column of infantry had edged-away, not from fifty or sixty musket-shots, which, had duty been done, was all that these horsemen could have been exposed to, but from some dangerous and difficult point of attack, defended by thousands of infantry and entire brigades of artillery. Why so much more daring should be expected from infantry than from cavalry, is of course not easy to understand, particularly if we consider that the very canter of a horse tends to raise and fire the soul of the rider. On fair and level ground, nothing but some obstacle capable of checking a horse at speed should ever be allowed to arrest the progress of cavalry; a proposition that gentlemen will do well to consider, before they allow Polish caps, hussar jackets, and "plumed helms," to lure them from the safer pursuits of peace into so dangerous and neck-breaking a branch of the service; for the time may come, when the chance of fifty or sixty musket-shots, and the brandishing of a few foolish bayonets, will not be received as an excuse for the defeat of an entire brigade of cavalry.

"To the changes resulting from bitter experience is the science of war constantly subject."—GERSDORFF.

It must not be thought, that in this endeavour to point out the insufficiency of infantry tactics, we are, therefore, advocating any of those methods of war that, as we have before shown, have on many occasions proved superior to our own. On the contrary, we are convinced that an army trained on European principles and conducted with ordinary talent will always, in the end, prove victorious over enemies possessing merely the wild energy displayed by the Turks and highlanders, or the skill of the Americans in distant fighting. But it must be perfectly evident, that an army, which should add to modern tactics the skill of the Turks in close combat, and that of the Americans in distant fighting, would naturally possess an incalculable

advantage over a mere tactical army as now constituted. And it is in the firm conviction that British soldiers possess above all other men the qualities necessary for the attainment of such skill in arms, that we venture to denounce the insufficiency of that mode of training, which, take it as you will, goes no farther than to make a man come into position and pull a trigger; a thing that, at the best, requires passive courage only; leaving energy and active courage, as well as personal strength and activity, those noble qualities of British soldiers, totally dormant, till called forth, under every disadvantage, in moments of extremity and in scenes of carnage, when the humbled pride of science is forced to rely for success and safety on the mere untrained and neglected gallantry of the soldier.

Most of us have at times had occasion to witness the active energy displayed by sailors in situations of difficulty; this has always struck foreigners, who are generally little used to naval habits, even more than ourselves, and those among them who fought in our ranks, and who have done justice to the gallantry of our soldiers, have nevertheless expressed a much higher admiration of our sailors. Heusinger, a German officer, who served with the Brunswick Hussars in Catalonia, says, in speaking of the quickness with which the batteries were raised and armed at the siege of Tarragona:—"It was owing principally to the almost superhuman exertion of the men-of-war's-men, that this was effected with such celerity under the heavy and constant fire of the fortress; but no labour was too great, and no situation too dangerous for these daring and undaunted men." No method of mere training can be expected to render the landsman equal, in point of handiness, to the seaman, whose entire life is a course of training, yet a great deal might be done by a good system of athletic and gymnastic exercises, were the advantages to be derived from individual exertion once fairly avowed. We have no means of accounting for the superior efficiency of the ancient armies in the field, unless by attributing it to their superior training; with them this resulted, no doubt, in a great measure from national habit, but exactly in proportion as the habits of our population unfit us for the toils of war, so should our mode of training make up for the deficiency. Polybius, himself a soldier of experience, estimates at only 3300 the greatest number of men that, from all different causes, could be supposed absent from the army of Alexander at the time of the battle of the Issus, though that Prince had entered Asia two years before at the head of 44,000 men, and had afterwards received a reinforcement of 6000 more.* Whilst the British army in the Peninsula, of inferior strength and the best equipped and the best provided for of any modern army, had seldom less than 10,000 men away from the ranks, mostly sick in hospital. And none who witnessed will easily forget the scenes of suffering that the track of wretched stragglers exhibited in rear of the newly-arrived corps during a long and fatiguing day's march; these men were only then beginning part of that course of military training which should have been completed before they were called upon to take the field. The men of the 5th division, who came to Quatre Bras, had been under arms the greater part of the previous night, had marched upwards of

* Polybius, Book XII. remarks on.

twenty-four miles on one of the hottest days of summer, each man carrying a weight of forty-six pounds, independent of what provision he might have in his havresack, and found at the end of such a march, not rest, but the deadly and desperate conflict that ensued. Yet this is the profession that requires no previous training, and that seems now destined to obtain no ultimate reward!

But the system, it seems, works too well to be changed: indeed! Did it work well when an entire battalion of regularly-drilled Sepoys were cut down to a man by a party of wild Arabs? Or, did it work well, when a strong detachment of the trained soldiers of England were forced to lay down their arms before a miserable crew of cowardly Albanians? Was its excellence particularly conspicuous, when the grenadier company of the 8th regiment were nearly all killed or wounded in skirmishing with some American Militia who were advancing towards York, and who, it is well known, would not have purchased the mighty honour of burning an old town-house at any great loss, had the followers of the system known how to inflict it? Sailors, or other men trained to active habits, would probably have succeeded in the attacks of Fort Christoval, Burgos, and in the first attack of St. Sebastian; but what did the wonder-working system do to aid the mere helpless courage of the soldier on these unfortunate occasions? At the battle of Aulroy, fought in 1364, the English archers, though unprovided with arms of length, rushed fearlessly on the French men-at-arms, tore the battle-axes from their saddles, and "did gallant execution with them." But on the 16th May 1811, an entire brigade of British infantry were defeated and taken by a body of French cavalry, who were not like the horsemen of former times, provided with defensive armour, whilst the infantry had muskets and bayonets; yet, owing to the immaculate system that works so well, the followers of that system were to a man cut down or taken, whilst their ancestors, listening only to the dictates of courage, and well knowing that an active man on foot must at all times, when he has room to move, be superior to a horseman, gained a complete victory. In war, the want of success is not always a proof of bad management, because in the greatest of all games of chance, fortune will at times turn even against the bravest and the best. But, in the cases above quoted, it was the system, and the system alone, that led to disaster, and, under similar circumstances, the same causes will lead to exactly the same results. Nor is it in these occurrences of minor importance that the insufficiency of modern tactics is alone to be discovered; for its evil influence naturally accompanied all our military operations from first to last, and made us fight long, and pay dearly for our ultimate triumph.

Owing to the bravery of our soldiers and the conduct of our officers, victors in every battle, we generally gained little more than the Spartan honour of maintaining the field of battle. At Vimiera, two-thirds of the British troops present defeated the entire of the French army, yet such was the system according to which these victors had been trained, that they allowed the vanquished to make good their retreat in open day, to dictate the convention of Cintra, and to return to the charge a few months afterwards. As this particular instance will, however, be ascribed to a curious and accidental succession of commanders, we may cite the battle of Vittoria as the most striking

of many other cases in point. The gallant onset of the British drove upwards of 50,000 French, with the loss of the whole of their *matériel*, from the field of Vittoria; but the system, the precious system, that confines the training of the soldier to the pulling of a trigger, prevented the victors from inflicting any heavy loss on the vanquished, of whom one-tenth only were killed, wounded, or taken, whilst the other nine-tenths were allowed to come back with fresh *matériel*, and renew the fight at Pampeluna; and again, after a proportionate succession of losses at Bayonne, Orthez, and Thoulouse. On all these, and many other occasions, one party constantly illustrated the truth of the Hudibrastic lines, that

“ He who fights and runs away,
May live to fight another day,”

whilst the other party as constantly forgot that only

“ Those who are in battle slain,
Will not return to fight again;”

for the men who ran away returned to fight again and again; but the brave and greatly daring too often suffered a tremendous loss, which, owing to their system of tactics, they had no means of avenging on their defeated foes. At Fuentes d' Onor, the Allies rested quietly on their arms as soon as the French called “Hold—enough.” At Albuera the gallant remnant of the victors had no means of inflicting any proportionate loss on their defeated adversaries; nor could they have stood a renewal of the onset; in the Pyrenees many difficult positions were carried in the most heroic manner, notwithstanding a heavy loss inflicted by the fugitives from Vittoria and Pampeluna, who were generally allowed to retire almost unmolested from the field, in order to return “and fight another day.”

There is yet a stronger proof to be adduced of the value of the system.

The numerous Austrian and Prussian armies that took the field at the commencement of the revolution-war, were trained and drilled exactly according to the system that we now pursue; and not a little proud the well-powdered and well-buttoned Soldadoes were of the supposed advantages their system and *savoir faire* gave them over the republican sans-culottes, who had no other tactics but *Ça-ira*, and no strategy but *en avant*; and who could only move in crowded masses, which they called columns, and from which, when they came to action, the boldest and most enterprising started forward to act as *tirailleurs*. Yet what was the result? The French soldiers, “bold with the strength that” fancied “freedom gave,” overcame the men of science, who were not a little surprised at such a result, but who, instead of looking for the cause in the natural intelligence and new *élans* of the French troops, attributed it to this new mode of fighting; and instead of calling forth and properly employing the native courage of the Germans, they took up the uncongenial system of their enemies, and naturally found themselves nothing the better for it. The French on their side, not wishing to owe their success solely to the gallantry of their soldiers, determined that their *génie militaire* should come in for a share of the honour; and thinking that some great physical force was mysteriously concealed in their unwieldy masses, they reduced the for-

mation and mode of attack to a regular system, at a time too when artillery was constantly increasing, and when the number of guns was already reckoned by hundreds in every field. This system, the most outrageous that ever entered into the heads of men, performed wonders by the aid of the conscription, and by the boundless rewards so liberally bestowed on the victors out of the spoils of the vanquished; who, on their side, were generally inferior in numbers and resources, and not unfrequently worse commanded even than the conquerors. The banner of European independence was about to be struck to folly and presumption, when the soldiers of England, ridiculed abroad, insulted and despised at home, appeared in the arena with the very same system of tactics so easily overthrown at the commencement of the war. But that system was now in different hands, and it soon became apparent that victory was to the strong and the valiant, and not to the feeble or worthless method of war that either of the parties followed. The stubborn courage of the British was not to be shaken by the fierce onset of the French columns. On the contrary, they generally reserved their fire with great coolness, a thing very trying to an advancing enemy, and though individually very bad shots, they could not altogether miss the entire of the masses that were moving against them. The consequence always was, that the assailants halted in order to fire, and as the front ranks only could use their muskets, the rest, left inactive and uselessly exposed, were naturally shaken; so that a charge of bayonets, a thing totally out of the conventional rule of European warfare, invariably put the whole to flight, though generally with what might be deemed a trifling loss. This was the constant tale from Vimiera to Waterloo, whenever the French were the assailants; and when the British were the attacking party, they had, from the natural hardihood of the men, still greater advantages. The approach of a hostile army, whose columns, glittering with arms, are seen advancing along the plain, and gradually expanding and taking post preparatory to the attack, is an imposing and majestic sight, and well calculated to augment the danger in the excited imagination of those who are quietly waiting the onset. Then the increasing report of artillery, followed by the sound of the balls fiercely forcing their way through the resisting air, and every now and then striking down a file or two, whose mangled limbs and agonized features add fearfully to the trying nature of the scene. The steadier the enemy, whose losses and waverings are no longer discernible as soon as the fire of musketry begins, advances, the more the hearts of the defenders sink and cool, the idea of danger quickly augments, and poor human nature directs all powers of thought to the means of safety. The assailants, on the other hand, derive a sort of wild courage from the very circumstance of advancing; the mere idea of attacking is "spirit stirring," and inspires British soldiers with a species of enthusiasm that constantly rendered them victorious, even under the most difficult circumstances, whenever the foe was fairly accessible.

Let it not be thought that a more energetic mode of warfare would be more sanguinary and destructive than the insufficient system we are here condemning. Alas! the reverse is the case; for modern tactics, by making battles less decisive, have rendered wars much longer, and

infinitely more destructive. In ancient times, when the combatants came to close quarters, a defeated army was annihilated; there was no escaping from the uplifted sword or lance; and a general action almost always settled the question at issue. Now, on the contrary, battles are fought at a distance; if an army finds itself getting the worse, it makes a skilful retreat, keeps the enemy at the respectful distance of grape and canister, and if ably commanded, frequently regains in detail, before the end of the campaign, what had been lost by an unsuccessful battle at the commencement. Thus, battles and skirmishes succeed each other with fearful rapidity, campaign follows campaign in melancholy succession; as the enemy is never destroyed, no rest can be given to the soldier; constant fatigue and exposure wear out the bravest and the best; and gaunt hunger, with its accompanying crimes and diseases, all the natural attendants of large armies and protracted campaigns, far exceed in their sweeping ravages, and a thousand-fold in their horrors, the more prompt and humane effects produced by the sword or sarissa on the field of battle.

How far now does the system, whose insufficiency we have been attempting to show, suit the character of our population—suit the sort of men who cut out the *Hermione*; who, in spite of boarding, netting, and of every other preparation made to oppose them, cut out the *Chevette* from under all the batteries of *Camarette Bay*; who boarded the *Chesapeake*, and, sword in hand, carried a Russian flotilla against countless odds in *Port Baltic*; who escalated *Badajos*, where not a stone of the fortifications had been injured, and where the most experienced soldiers, the conquerors of continental Europe, were waiting to receive them; who stormed *St. Sebastian* in open day, and calmly waited exposed to all the fire of the fortress, under an impracticable breach, till the shot of their own guns, striking only a few feet above their heads, rendered the passage practicable, and then rushed upon the astonished enemy with a degree of fury, that neither the skilful contrivances, nor the avowed courage of the defenders could resist,—leaving it doubtful whether their stern composure, whilst calmly waiting amidst the heaps of dead and dying, or their subsequent impetuosity, was most to be wondered at, but leaving no doubt as to the invincibility of such men, whenever their training and system of war should do justice to their unconquerable qualities? If such actions were performed at the cold call of unrewarded duty alone, let those who know the inflammable materials of which the human heart is composed, say what might not have been done by these soldiers, if they had been taught to take a pride in their personal strength, activity, and skill in arms, and encouraged to look for results and honest applause from their individual gallantry and exertions. Recollect *Crastinius* before the battle of *Pharsalia*, “This day, *Cæsar*, thou shalt praise me dead or alive.”* Let us never hear the unworthy assertion so often repeated, that British soldiers are incapable of enthusiasm; for, notwithstanding the blighting effects of many parts of our system, countless instances of heroic devotion on the part of private soldiers may be adduced. Our limits

* *De Bello Civili*, lib. 3.

prevent us from quoting more than one case, but it is sufficiently to the purpose. During the war in Upper Canada, two soldiers of the 49th Regiment were posted in front of a small bridge that crossed a ravine or rivulet, and were ordered, for what reason we know not, to defend it to the last. They were there surrounded by an entire division of the American army, and asked to surrender, but regardless of the inevitable consequence of resistance, and mindful only of their orders, these brave men rejected the offer, and fell nobly fighting on the post intrusted to their charge. Greece would have erected statues to their memory, and Leonidas has been justly immortalized for doing nothing more.

Without, at present, entering into any discussion as to the improvements that might be made in our mode of tactical training, we may simply ask whether the actions above cited would not furnish better hints for a British system of tactics, than the old German Regulations of Lascy and Saldern, remodelled in 1824, and so erroneously called new, though not containing a single new principle; that is, containing nothing that any one *properly* acquainted with Dundas's book might not easily have performed off-hand on any morning parade.

Many of the causes of that insufficiency, of which we have been speaking, lie beyond the sphere of our present inquiry; but the principal blame for having occasioned so much weakness and bloodshed, must be ascribed to that factious opposition which, aided by an ignorant and libellous press, strove from the very commencement of the war, to embarrass the Government, and to crush the rising spirit of the army by every measure of insult and oppression. One set of men were found sufficiently ignorant of the constitution of their country, to suppose that the liberty of England could be overthrown by English* soldiers, who were consequently looked upon as enemies, and treated accordingly. Another set, in utter defiance of all history, ridiculed the idea of an English army being able to contend against the legions of France, laughed at our pretensions to military knowledge, prophesied only disaster, ruined the army in the estimation of the country, and forced upon the Government, never distinguished for the vigour of its foreign or military policy, a line of conduct towards the profession, that for a long time rendered the development of all military talent, pride, and exertion, next to impossible. To husband our resources, in order probably to allow the enemy to gain strength, was the constant cry, but not a single voice was raised in favour of a bold and noble system of military policy becoming our former deeds in arms and national fame. One brave and generous spirit who, by mere appeals to history, and to the actions of our seamen, should have put down these mouthings of the pompous, and the sneers of the supercilious, would then have been worth a hundred thousand men; but none such appeared: and though the British army that landed in Egypt was proclaimed by that action alone the first army that Europe had seen since the fall of the Roman legions, still it could not shake the cowardly spirit that

* They have done so before, it may be said. No, they only overthrew a Parliament that had usurped all the power of the Government, and overthrown the liberties of the country.

years of falsehood and misrepresentation had cast over the country at large; and the empires of the Continent were one after the other allowed to fall under the blows of France, whilst the British Government was shamefully forced to keep the never-conquered soldiers of England idling at home out of harm's way. What was the end of a drama now about to be acted over again? After armies had been frittered away in distant enterprises, that, till the Spanish revolution, led to no efficient result, the tide of war, as if in awful mockery of the feebleness with which it had been conducted, rolled back again to the very spot that a quarter of a century before had witnessed its commencement; and where at last 25,000 British soldiers, aided by the very same allies at whose side they had fought at the outset of the contest, decided its fate in one single battle; leaving the torrents of gallant blood that had been shed, and the millions of treasure that had been expended from the day of Valmy to that of Waterloo, a reproach to the past, and a warning to the future. But the warning is not attended to; for though the army have by their gallantry fought themselves into favour with the nation at large, yet there is still a numerous party, who, with the facts just stated full in their recollection, are endeavouring to force the country into the same line of conduct that led to so much loss and suffering. Every measure that can directly or indirectly detract from the honour or character of the army, every piece of penny wisdom that can diminish its number or comforts, though sure to end in pound folly, is, year after year, and day after day, forced upon the Government. No circumstance, however trifling, that exaggeration can raise or stupidity construe into a charge against them is passed over; not an apple-stall can be accidentally upset by a passing relief in the streets of London, but the outcry of military oppression is raised and repeated even by grave magistrates on the bench.* In a riot, a soldier cannot use the right undeniable to all God's creatures of defending himself, but the yell of military outrage is repeated from dunce to dunce; men who have served with honour and distinction in the profession of arms, the best school perhaps for most official situations, cannot be appointed to any civil department of the State, but the shout of a military government is set up by the whole enlightened crew of modern philosophers. According to them, honour, loyalty, gallantry and patriotism, are public nuisances,† and should be scouted out of society: we are a naval and commercial people, and require no such articles, for they are not exchangeable in the public market. But Tyre, Carthage, Venice, and Genoa, were commercial nations, and what are they? What would our naval and commercial friends the Dutch be, but for that very army it is so much the fashion of a certain set of writers and speakers to traduce? Disband the army, or, what is the same thing, destroy the spirit that alone renders it formidable, and the loss of the East and West Indies, Canada, the Cape, and our Mediterranean possessions are the instantaneous results; for no one who has ever seen a weather-cock veer about upon a London steeple, can well be so simple as to suppose that any

* See London Police Reports for 1828.

† Westminster Review. Mill's History of Chivalry.

spot on earth can now be defended by fleets alone. But if the army cannot be altogether reduced, its pride may be broken and a cheaper commodity may be obtained. Easily, no doubt; but "as ye sow so shall ye reap." Deprive the military profession of the halo that surrounds it; destroy all these energizing sentiments and feelings, (the result of illusion, perhaps,) that still attach themselves in the breast of the soldier, and of the better part of mankind, to the "pride, pomp and circumstance of glorious war," and there is an end to the army. Take bright honour out of the scale, extinguish that aspiration after fame and distinction, that longing for danger and the boundless elasticity it confers, and before which obstacles vanish that would make mere calculation shrink back appalled, and the profession of arms becomes one of unrewarded suffering and danger, and the most ungrateful to which men can devote themselves.

What is to be expected from such degraded armies, destitute alike of courage, discipline, and patriotism, may be learned from the late revolutions in Spain, Portugal, and Naples. The records of mankind furnish but one continued proof of the melancholy fact, that armies and arms alone have been able to protect men, whether living in great or in small communities, from the rapacity of those who were strong enough to despoil them. Turn the blood-stained page of history which way you will; let sophistry misrepresent, and party spirit falsify, still is this the grand and leading truth that everywhere presents itself, and naturally calls aloud to arms. The last age witnessed the reign of Catherine the abhorred, and saw her constant aggressions on unoffending Turkey, and the dismemberment of Poland:—as we have, in our day, seen the wars "for power, for plunder, and extended rule," carried on by the different demagogues of France, from the imbecile man of blood, who governed by the guillotine, down to the mighty man of little mind, who reigned by the sword. The very same principles that thus deluged the East and West with blood, and ultimately brought the French to Moscow, and the Tartars from the frontiers of China to the banks of the Seine, are again opposed to each other on more distinct and avowed grounds of hostility. A war of extermination is about to be waged, and it behoves us to ask ourselves what we have to expect from the conquerors. If the autocrats prove victorious, as with ordinary conduct they probably must, will they not strive to extinguish in this country the last sparks of European freedom? If the French prevail, have they not the long and rankling list of defeats from Cressy to unforgiven Waterloo to avenge? Did our boundless aid in the day of danger and adversity make the Continental Sovereigns our friends? or did our generous forgiveness in the hour of victory soothe the wounded pride of vain-glorious France? To talk of the principle of non-intervention under such circumstances, is an idle waste of words, and to act up to it would be criminal. We are the last stay of European liberty and civilization, and must no longer allow ourselves to be guided by the Utopian doctrines of itinerant spouters, or by the idle theories of an ignorant and factious press. We must look to history and experience,

"And learn to guide the future by the past."

J. M.

SONG OF A PEASANT GIRL AFTER THE BATTLE OF
LEIPSIC.

You sometimes indulge, Mr. Editor, in a stray song or sonnet. The enclosed is from the German; and if you think it worth a place in your Journal, it is infinitely at your service.

I do not plague you with the original, but will only observe, that the translation is almost literal, and that the only difficulty has been in approaching the former's plaintiveness and simplicity.

Yours,

AMICUS.

THE fight is won! the foe is flying—
Hurrah, my girl! my father cries;
Away vain fears and useless sighing—
For Freedom is the battle's prize.

True to his home and country's altars,
Each German lifts the sword to save;
And think, ye maidens, what an honour!
My Henry fights among the brave.

Ah! who shall tell my parting sadness
When glory call'd him to the field;
But now my heart is fill'd with gladness,
Because his courage was our shield.

How often when the news was brought us
Of many a gallant action done,
I said, "Our bands must needs be noble,
For Henry, my beloved, is—one."

But yesterday my joy was doubled,
When down the printed tidings came;
My father read and cried delighted,
And call'd me loudly by my name.

My child—my Bertha—'tis decided!
Again our father-land is free;
And now the terms of peace are settled—
And Henry's surely there to see.

On Saxon ground the foe was routed,
And Leipsic saw the battle's shock;
I scarce can number all the trophies,
Or count the captive crowds we took.

How many waggons deeply laden
With powder and with ball were won;
How many cannon there were taken—
While Henry in the strife was—one.

In every eye is joy and gladness—
The shout of Freedom fills the air;
Yet, there be maids who pine in sadness,
Because they had no Henry there.

But hold, my heart! what fearful numbers
I hear of slaughter'd in the fray;—
How, if my Henry's name's among them—
Ah, no! he was not there that day!

ON THE DISCIPLINE* OF THE MERCANTILE MARINE.

“ White is the glassy deck without a stain,
 Where on the watch the staid Lieutenant walks :
 Look on that part which sacred doth remain
 For the lone chieftain, who majestic stalks,
 Silent and fear'd by all—not oft he talks
 With aught beneath him, if he would preserve
 That strict restraint, which broken, ever balks
 Conquest and Fame; but Britons rarely swerve
 From Law, however stern, which tends their strength to nerve.”

BYRON.

We have just risen from the perusal of a work on this subject written by Capt. Christopher Biden, an old and meritorious officer of the East India Company's service; and who, from having progressively advanced to his present rank and held the command of two fine ships, may be presumed to understand well what he writes upon. The book is rather discursive in its arrangement, but it presents an aggregate of facts which fully merit the attention of our Government and the public at large. To the gallantry and general merits of our Indiamen, of which he adduces many instances, we willingly add our warm testimony; for certainly, no such efficient traders ever floated upon the waters: and their discomfiture of Admirals Suffrein, Sercey, and Linois,—their ready co-operation in various expeditions,—and their resolute encounters with formidable frigates, have stamped them with unfading credit. Nor can we forget the glow of gratification with which we observed the astonishment of some Spanish prisoners on board a frigate we then served in, at being told that a fleet which we met off Lintin, consisted of British *merchantmen* only; for they might easily have been palmed off as *line-of-battle-ships*. Capt. Biden after reciting several spirited actions, remarks:

“ The high order and warlike appearance of the China ships frequently drew forth the highest encomiums from admirals and captains in the navy, and the distinguished approbation of Admirals Cornwallis, Rainier, Sir S. Hood, Lord Exmouth, Ferrier; Captains Pym, Austen, Sir Henry Heathcote, &c. I well remember the favourable notice bestowed on the China fleet by the late Capt. Bissell, who convoyed us an eastern passage to China, in the most able manner. His subsequent melancholy fate off the Isle of France, with the gallant Sir T. Troubridge, deprived the navy of a brave and most able officer.

“ The Royal George, in which ship I served for seven successive voyages, was frequently taken for a frigate; and when we fell in with Sir E. Pellew's squadron, the sloop of war sent by the Admiral to speak us, delivered the following message:—‘Tell the Captain if he had not his main-top-mast stay-sail in the brails, I should have taken his ship for a frigate;’ this trifling incident was not lost upon me, and is worthy the notice of every young officer, who should keep his ship in that ship-shape order, and ever do his duty as if all eyes were upon him, particularly when falling in with a ship at sea: *sailors are severe critics.*”

Nor has the gallantry of the mercantile seamen been confined to the floating castles of India; for innumerable encounters with privateers,

* Naval Discipline, &c. &c., by Christopher Biden, late Commander of the Hon. East India Company's ships Royal George, and Princess Charlotte of Wales.

and successful stratagems, have distinguished our trading vessels over the whole globe. When Lord Howe, in 1778, was menaced by the powerful fleet of M. d'Estaing at Sandy Hook, he moored his ships in the best order for defence, but still had the mortification, during several days, of seeing captures made, without a possibility of affording relief. Upon the appearance of the enemy, 1000 volunteers from the transports immediately offered their services to man the men-of-war; and such was the ardour among these brave fellows, that even many of those who it was necessary should remain to take care of their respective vessels, were found concealed in the boats which were employed to convey their more fortunate companions on board the ships. The zeal displayed by the masters and mates of the merchant vessels at New York, was equally meritorious; they earnestly solicited employment, and cheerfully took their stations at the guns, and assisted in all the duties of foremast-men: others put to sea in light craft to watch the motions of the enemy, performing various essential services; and one in particular, with a noble disinterestedness, offered to convert his vessel, which was the whole of his fortune, into a fire-ship, to be conducted by himself. In the wars which arose out of the French Revolution, a similar energy has been frequently manifested; and we have personally witnessed the conspicuous public spirit, and voluntary bravery, with which many were actuated on the expeditions to the Scheldt, and the Tagus; at Cadiz, and in the Mediterranean.

Such being the claims of our mercantile marine, we are now called upon to express our regret on witnessing the recent attempts,—at least, as far as they can be accomplished by general assertions and indiscriminate abuse—to disparage our commercial interests, by maudlin newspapers palliating the mutinous conduct of a gang of refractory seamen. It is in evidence that the crew of the *Inglis* dictated to their commander and officers; that the ringleader incited his shipmates “away to the arm-chest;” and that another clapped the Captain on the shoulder, telling him, “here’s three cheers for you, by way of defiance!” There can be but one sound opinion as to this heinous misconduct; and if such inflammatory language and action do not meet with exemplary punishment, the most ruinous consequences are inevitable. But how does that dictatorial monster “*THE PRESS*” take up the matter? Instead of advocating the cause of order, and upholding that source of employment which fosters our naval strength, the newspapers in general have ponred forth a sentimental diatribe on the wickedness of retribution; and with calumnious clamour have thrown down the gauntlet in favour of drunkenness, insolence, and disobedience. By their statements it would appear to have been given in evidence that the prisoners sent from St. Helena, in the *Vansittart*, were seventy-two days in irons; whereas, Capt. Scott, Commander of that vessel, declares that, on the fifth or sixth day subsequent to their departure from that island, these men were released from irons, and only re-confined when the ship entered the river Thames. Nor should it be omitted that the term used is, “sent home heavily ironed,” by which, instead of merely being moored by the leg at a bilbo-bolt, the credulous landsmen would receive an impression that the “unoffending” scamps of the *Inglis* were manacled and fettered, like the felons in Newgate.

But it is not with a view of noticing such licentious distortion of

cases, or to dwell upon the real and assumed state of the facts in question, that we are now writing. Our object is to assert the necessity of inquiring into the causes of the progressive insubordination on board our trading ships; and also to point out the truly defenceless condition of the officers and passengers of a ship in a state of mutiny. As to wanton severity in the Company's officers, it is rather investive than argument; for, however an individual or two may have misbehaved, there can be no reflection on the humanity of the commanders of that service at large. Harsh and unjust officers can always be made responsible, and no tyranny can ever palliate disaffection, or be made the plea for piracy or murder. It is certain, that evil passions have been excited and pampered, and the sovereignty of brute force appealed to; and it is also clear that the general interests and character of the country should no longer be trifled with. The spring of industry which unites the entire human race in common wants and mutual obligations, by overcoming the obstacles of distance and climate, and which augments at once the wealth of the state and the comfort of its inhabitants by "bringing into it whatever is wanting, and carrying out of it whatever is superfluous,"—this spring should be an object of the greatest national solicitude. And we trust that an occasional exposure of flagrant grievances will draw attention in the proper quarters; thereby proving, that neither the government nor the public are regardless—the first of its most sacred duties, the last, of its best interests.

The nature and extent of our mercantile marine are not, perhaps, so generally appreciated as they should be; for ships being machines of national power, and means of civilization, are the noblest property which a country can possess, independent of the soil. At the close of 1826, the number of trading vessels actually belonging to British ports, was 24,280, with a capacity of 2,553,685 tons; giving employment to 166,583 sailors and boys. In addition to these, the British empire possesses 3,579 ships (many of them of force as well as burthen) which belong to her colonies,—and when we further consider the vast numbers of persons on our quays, docks, and rivers, who derive their subsistence by attending them, the magnitude of the object must rise in estimation. Yet England, whose principal moving power is commerce, is the only maritime nation without a legalised code of regulations for the discipline of those engaged therein; no law defining the extent of obedience that is due by the sailor to his superior, or the protection which he ought to receive against the abuse of authority;—in fact, no recognized bond or principle to govern their mutual relations. It has been said

" Captain, look out, 'tis your concern,
To govern well from stem to stern."

but how can he manage it without legal authority? And considering the discordant elements often found on his decks, it is matter of marvel how any semblance of order has been maintained at all. It will be a cause of gratulation when our Government can quit abstract theories, and descend to affairs of practical utility, amongst the first of which is the unprotected situation of the commercial marine; for unless some recognized formularies can be adapted and adopted, the litigious spirit abroad will strike at our maritime greatness. Nor is he altogether wool-gathering who has pronounced, that as mutineers must not be

confined, nor sailors coerced,—the captain of a ship will shortly be expected to take off his hat to the watch, and say, “Gentlemen, if you please, that is, if you consider it quite consistent with the principles of Magna Charta and the liberty of the subject, I should feel particularly obliged to you, if you would do me the favour to go aloft and take in top-gallant-sails.” And in the twelfth century, the Oleron laws actually enforced something very like this, for it was expressly ordained:—“If a ship or other vessel be in a port, waiting for weather and a wind to depart; the master ought when that comes, before his departure to consult his company and say to them:—‘Gentlemen, what think you of this wind?’ If any of them see that it is not settled, and advise him to stay till it is; and others on the contrary would have him make use of it as fair, he ought to follow the advice of the major part.” Who would return to this absurdity?

Method, in naval affairs, has been compared to salt in seasoning—as too little is insipid, so too much is offensive. Now it strikes us, that a principal cause of the demoralization of our seamen, sprung from the impolitic and disgraceful practice of foisting common felons, and United Irishmen, throughout our fleet; and that the gradual relaxation which has taken place in our men-of-war, has occasioned the entire absence of discipline in the merchant service;—an absence which debases the seaman, and is at once the cause of his petulance, and the intemperate endeavours to enforce authority on the other side. It has been decided that a captain is justified in using illegal means to enforce a legal order; but there are few commanders who do not quail before the heavy expenses of a legal justification. Most of them would rather clear for action with an enemy, than *engage* in a court of law: what with jargon and technical riddles, delays, and vexations, they would prefer the battle and the hurricane to the quibbling sons of sophistry, with their big wigs and parchment. In fact, the service is pestered as with a gangrene by the pettifogging outscouts of Doctors’ Commons—that antiquated sink of precedents and heavy charges! And the route of these carrion crows may be traced by the withering mildew visible in their wake: to these “the sea-attorneys” make their court, and the mischief begins,—for the most indolent and worthless of those embarked, have been often known purposely to provoke the anger of their betters, with a view to law and future damages. Generally speaking, our commercial system is founded on more enlarged and liberal principles than that of any other European country; but in the particular department of Marine Law, it can lay claim to no such distinction. On the contrary, this supposed ægis of a most important department of industry and finance is subjected to very oppressive regulations. Of the evils which masters labour under, Capt. Biden cites numerous cases, from which we will submit one at random:

“Shipped on board the *Lady Raffles*, bound to Bombay, in the month of March 1828, at Gravesend, fifteen men, that had been just paid off from the *Albion* seventy-four, at Portsmouth. The ship anchored in the Downs about three days after the men had been on board. After the ship had received her passengers and provisions on board, the hands were turned up to get the ship under weigh (the wind being fair) when the fifteen men already mentioned, refused to assist in manning the capstan. Capt. Tucker called them aft, when they stated that they were willing to go in the ship,

but that they did not intend to put their hands to a rope, or assist in any way to do the duties of the ship during the voyage, unless they could be allowed one pint of rum per day; which Capt. Tucker then refused. He applied to Capt. Pigot of the *Ramilies* (the guard-ship) for his assistance, to compel the men to go to their duties, they having signed the ship's articles, and received, each man, his two months' advance in cash. Capt. Pigot stated that he dared not even punish a man on board his own ship, as she was under the district of a magistrate, and therefore, he was sorry he could do nothing to assist him in the business, but advised Capt. Tucker to apply to the magistrate at Deal; he did so, when the magistrate told him that if his people, after having signed articles, had refused to go in the ship, or deserted the ship, he could punish them, but he was not authorized to compel them to do the duties of the ship, neither could he assist Capt. Tucker in the case. Upon this, Capt. Tucker went off to the ship, and called the men aft again, and told them he would give them a pint of rum per day, if they would return to their duties, when twelve of them stated that, if he had conceded to their wishes at first, they would have assisted to get the ship under weigh, but they would not do so now; upon which, after the ship had been detained three or four days in the Downs, with a fair wind, twelve fresh hands were sent down from London at a great expense, and the twelve offenders allowed to quit the ship unpunished.

"Mr. Richard Green, owner of the *Lady Raffles*, who furnished me with this statement, applied to the Thames Police for the apprehension of the above men, and was recommended to prosecute them; the magistrate could suggest no other remedy.

"The valuable time already sacrificed by such infamous conduct as the seamen of this ship betrayed, besides the considerable expense that was incurred, stamp the whole affair with the greatest disgrace, and is an excellent commentary on the oft-told tale, that subordination is to be sustained by an appeal to the civil power.

"Let it be considered who are the party which a zealous owner is required to prosecute: a few sailors without a shilling beyond their ill-got plunder from the *Lady Raffles*. And have owners of ships no other duty to perform? In this case, a valuable ship, full of passengers, bound to Bombay, having a fair wind, had already been shamefully detained; a prosecution would have been followed by further and more serious detention; the Captain must have been detained as a witness, or bound over to appear: in fact, such proceedings, warped as justice is by the knavery of pettifogging lawyers and perjured clients, are all a farce."

As to the moral operation of the Admiralty Court, nothing can be worse,—for it is a scourge on the ship-owners, as well as the masters, from its expensive and inquisitorial *ex-parte* mode of procedure, and the meretricious stages by which it pursues its inquiries,—running up steam-boat accidents for decisions under the Rhodian laws. Thus a case has come within our cognizance, of the owner of a brig from Smyrna, who by searching after the relations of a deceased seaman, in order to deliver to them the clothes, and balance of wages, awoke one of the sharks which infest the eastern regions of London. This fellow, with the utmost effrontery, produced a paper, evidently just written, by which the deceased bequeathed every thing to him. The gentleman was resolved to treat this iniquitous attempt with utter disdain, if not to punish it: but the wretch, aware of the nature of troubled waters, exclaimed,—“No, no! *Prove* me in the wrong first. Pay me, or I'll have you into Doctors' Commons. Where are your *proofs* of this paper, being forged? Produce them, else my story remains good.” Our friend writhebed from the bottom of his heart, for he saw no

mode of resisting the infamous extortion, and he well knew that he could not get out of that court, even with an acquittal, under an expense of fifty pounds. He accordingly delivered up the property, with a resolution of giving the sailor's relations a similar amount from his own purse if they should ever come forward. A day or two after the transaction had taken place, he was called upon by another man, one of the crew of the vessel, to acknowledge that he had confederated in drawing up the forgery, but that the principal had defrauded him of his share of the spoil!

Our author also adduces instances of compromises being made, rather than incur expenses, of which we will cite one of Capt. Driver:

"When I commanded the Clyde, in the free trade, one of the seamen stabbed my chief mate. I considered myself fully justified in flogging him; but one of the rascals attempted to rescue this blood-thirsty villain. To preserve any thing like discipline, I flogged him also, but only inflicted eight lashes. However, on my arrival, I had one of those hornets after me, called proctors. I employed another; who said, if I gained the suit, the expenses would be heavy; and by his advice, I gave the informer ten pounds; this I did, which, in reality, is paying a man for behaving ill, and rewarding a fellow for attempting to rescue an assassin."

"England is a land which can never be conquered," says Raleigh, "whilst the Kings thereof keep the dominion of the sea;" and that dominion is only to be maintained by unceasing vigilance to nautical interests in all their ramifications. Now it appears that the only control over merchant seamen consists in their signing certain articles, and if they desert, forfeiture of wages; but this has no weight in preventing neglect of duty, provoking behaviour, or mutiny. On arrival in port, in nine cases out of ten, the magistrates decline interfering, and nothing is left but to be saddled with a lawyer's bill. And after all, what are fine and imprisonment to men, who disregard expenses, and are inured to confinement? It is therefore clear that distinct legislative enactments, and a methodized system of action, are absolutely necessary; and that a temperate discipline is requisite for the support and encouragement of willing good men, against lazy skulkers. For real order does not wholly consist of mere passive obedience to arbitrary regulations; laws must be portioned and adapted to the various wants and exigencies of all classes concerned, since they may become a poison or a panacea, according to the judgment with which they are administered. To accomplish such an end, there may be many prejudices to overcome; but the subject, being fraught with serious consequences to the national prosperity, is too important to be glozed over. When seamen were less instructed, they were more easily moulded to customs and usages, which they never thought of scrutinizing. Sunday papers, and designing sea-lawyers, however, have made the restless spirits quibble without reason or moderation. Now when men question quarter-deck authority, and assume the right of measuring out their employment, so as to accord with their own crude ideas, the necessity is evinced of establishing into laws whatever is permanently necessary. In strict justice we would advise that skulking, contempt, and refusal of duty, quitting the ship without leave, habitual drunkenness, and theft, should be severely punished;—always bearing in mind the Nelsonian axiom that—"lenity at first, is severity

at last:" on the other hand, we advocate that there be a controlling power over the victualling of merchant ships; for short allowance, bad provisions, and various irregularities in that department, have been a never-failing spring of discontent. The ratings and wages should be scrupulously classified according to individual merits, and the stations of petty officers awarded to those only who are remarkable for emulation and excellence. Trifling and vexatious modes of carrying on duty ought to be avoided, nor should the hands ever be turned-up, when the watch is capable of performing what is required to be done. And to rivet the links of that chain of willing obedience which is the soul of good order, indiscriminate abuse, and blasphemous oaths, must be abolished on both sides; though we cannot bring ourselves to believe the feelings of sailors so sensitive, as to suffer under a hearty damn, as hath lately been pithily shown by the hue and cry hounds of the "Press." Contemptuous treatment rankies more than all the curses and myriamorphous execrations which could be heaped upon them in the heat of hurry; for they never hold with Maw-worm that they "likes to be despised."

In the executive movements of a ship, much of the disposition and tact of a good officer is apparent. Thirst for popularity is apt to warp the judgment, and we would strongly recommend every one in charge of the deck duties, to act with circumspect impartiality, as the best mode of insuring subordination and smartness. By fully endeavouring to ascertain each man's individual qualifications, an officer can make his arrangements accordingly; his system should be clear and methodical; the execution of it precise and regular. Let him be mindful to afford leisure at stated periods; and as far as service admits, to promote a pride of ship, by permitting the music, dancing, and active festivities, in which every seaman delights: thus—

"Teach him fatigue and labour to despise,
Nor heed or boisterous winds, or frowning skies."

In the preamble to the Act of Parliament passed when William and Mary gave up the palace at Greenwich, for a naval hospital, this appropriate eulogy occurs.—"And whereas the seamen of this kingdom have for a long time distinguished themselves throughout the world, by their industry and skilfulness in their employments, and by their courage and constancy, manifested in engagements, for the defence and honour of their native country." Such was the proud character of our tars at the close of the seventeenth century: and we need not appeal to the names of Leeke, Rooke, Hawke, Howe, or Nelson, for evidence of their having strictly maintained their credit: it is imperishably written in the annals of nations.

And here let us dwell a moment upon the character of the British sailor,—not the grass-combing squad which is found intermixed, but the regular huilt water-dog—the "pitcht peece of reason" of Sir T. Overhury. Unlike the mariners of most other nations, who merely bear with the privations of sea-life for the sake of its emoluments, the Briton is almost the only one who hetakes himself to the ocean from his tenderest years "for better for worse," and can hardly be tempted, even in his old age, to live on shore, or at least, out of sight of salt-water. He is inured to withstand the various assaults of heat, and

cold,—wind, waves, and enemies; and whether in the battle or the breeze, will stick to his duty like a barnacle to a ship's bottom, under the axiom that if he is to strike, it is better to die "doing something." He will no more think of shrinking or dodging than the mainmast. His life is one of high occasional excitement, and prolific enough from time to time in occurrences of deep interest. From the playfulness of his disposition, he has been described as the oldest "boy" who wears a jacket—a sort of child on man's scantling; but whether in a lark, a sheeve-o, or a bit of mischief, he never forgets the deeply-implanted creed,—“messmate before a shipmate, shipmate before a stranger, stranger before a dog.” He is as innocent of logic as an archbishop is of navigation, yet becomes argute upon some points, and will spin you a yarn as long as a lead line, wherein he advances many matters not laid down in-books; if he has occasion for raking, he seldom fires wadding only, and if hard pushed, throws his ashes to windward, and runs his cable to the very clinch. He likes that every thing should be above-board, and in its regular chaunel; and though he can batten on provisions which are neither wholesome nor toothsome, still he does not relish banyan days, nor six-water grog, because, he will tell you, he merely likes grog for the sake of the *spiritual* liquor that is put into it. With this capacity of endurance, and a thoughtless indifference to self, he becomes familiarized to danger, and his thoughts on this head rarely give much trouble to his tongue. Thus inured from early age, he is fit for any service, even for that lingering harassment—the blockade of northern ports,

“Where clouds, and fogs, and darkness drear,
Obscure and sadden half the year.”

Nevertheless it must be confessed, that his frank disposition, his staunch courage, his headlong desperation in following an officer, and his steadiness in danger, are partly counterbalanced by occasional discontent and improvidence. This may in some degree originate in the restraint over his actions when afloat, want of reflection, and the limited nature of his shore-going cruises: but this we will vouch for, that when a sailor deviates from his wonted honesty, his vices seldom partake of turpitude; and it will be found that some *sea-lawyer* is at the bottom. A thorough sailor once sailed with us, as a quarter-master, and on our return to England, it appeared that he had served the time stipulated for a pension, except that the three first years were lost, by his having run from the service. Yet, as his subsequent conduct had drawn the warm approbation of his several commanders, we did all in our power to get the obnoxious R taken from his name; but the Admiralty were inexorable: on pleading his excellent behaviour under our own eye for four years, it was properly enough remarked that, “the better the man, the stronger the example.” On informing him of the result, we questioned him as to how he came to be so silly as to desert? had he been harshly treated? or what? “No, Sir!” was his reply, “I never was more comfortable, but a galley-growling chap persuaded me.” “But,” demanded we, “why did you alter your name?” “Oh, it was the fashion then, Sir!”

Such being the *raw material*, is it to be wondered at, that, subject to frequent and irregular changes from deprivation to enjoyment, and

influenced by various deep-rooted habits engendered on the ocean, sailors should be stamped with a generic character, eccentricity of manner, utter carelessness about the present, and utter fearlessness about the future? The navy watches them with paternal care, as can be testified by many a "goose" at Greenwich. But far different is the fate of merchant seamen. They are turned adrift the moment their ship gets into dock, their places are supplied by lumpers, and they are no more regarded by either master or owners than so many bags of shakings would be: and it has been established by evidence before Parliamentary Committees, that this custom, in one branch alone, the coal trade, adds more than a hundred thousand a-year to the amount of the consumer's expenses; for the crews of colliers are absolutely prevented from performing the delivery of their cargoes, which ought to constitute an independent part of their peculiar duty. On landing, it may be that Jack's purse is tolerably ballasted with rhino; his first object is to purchase a watch, which he insists shall be a *strong* one; his next is to rig himself with true-blue, and long-quartered shoes, in all the taste of a Sea-Adonis. Perchance he mounts a horse, when away they go with more velocity than discretion, and he is lucky if not speedily thrown on the mane,* for the steed is usually some rip too well known to be bestrode by any but a stranger, and either as frolicksome and wild as Mazeppa's, or as ill-conditioned as Rezinante. The cruise and all its nameless consequences rapidly follow—a southerly wind enters the pockets, and in a few days the ephemeral Cæsus is taken in tow by the heartless crimps; and so far from the burnt child dreading the fire, this is repeated each voyage, with little variation; for the unreflecting tar, acquiring no experience from the past, is ever open to fresh temptation. Now we maintain that it will be a worthy legislative enactment which will bind the employers and the employed by stronger ties, and thereby rescue the latter from the snares of the unprincipled scoundrels who snap them up. Still more lamentable is the shameless destitution of their old age, which, from the alternating vicissitudes of their avocation, is too frequently premature. When worn out, gaunt misery "marks them for her own." See the contrast of the man-of-war's man: at comfortable moorings, he still associates with his kind, fights his battles o'er again, and may even find messmates with whom he had joined in the shout of victory. We recollect a picture of touching interest in Noble's didactic poem "Blackheath," where a veteran sailor is described sitting under an elm in Greenwich Park, and watching the ship, in which he had fought, coming up the Thames to be broken up:—

"On his rough brow, remembrance fondly gleams:
His brighten'd cheek through all its wrinkles smiles:
While frequent cross his eye, his moisten'd sleeve
Drawn hastily, wipes off some starting tear."

It must be admitted that though our tars are as brave as lions, yet like these noble animals, they are unmanageable by *green-horns*. Indeed their reckless bluntness of manner very frequently leads them into serious dilemmas; but their rage, like that of the scorpion, mostly

* Quere, ought not this to be *main*, as the sailor's place?—Printer's D.

recoils on themselves. In the heat of the moment they will follow any example, however outrageous; and therefore those who "go down to the sea in ships and occupy their business in great waters," ought to be duly organized. Captain Biden relates numerous anecdotes of this refractory spirit, of which we will extract one, by way of instance.

"Captain W. H. Biden, commanding the *Thalia*, going upon deck on the 14th of October, at sea, observed several of his crew swimming under the bows and alongside; he questioned the officer of the watch about allowing such impropriety, considering the danger from sharks, &c., who replied he had ordered them in, but they would not obey; the boatswain had endeavoured to prevent the men going overboard, without effect: the captain then ordered them on board. After some hesitation on the part of Thomas Rogers, (seaman,) this order was obeyed; the hands were then turned up, and the ship's company were made acquainted that swimming or going overboard was contrary to the regulations of the ship; a spirit of disaffection betrayed itself among several of the men, and Rogers came forward in the most daring manner, declaring he would go overboard in spite of the Captain or any one else. This man's insolence became so inflammatory, that he was ordered on the poop, which he reluctantly obeyed, but burst out into mutinous language. Captain Biden then ordered him to be placed in confinement; he then became outrageous, seized an iron belaying-pin, and threatened to knock down the first person who attempted to put him in irons, and made all the resistance in his power. The Captain then endeavoured to wrench the belaying-pin from him, and succeeded, at length, in securing this turbulent fellow, upon which two other seamen declared they would also go in irons; they were in consequence sent as prisoners on the poop. This was not the first or second offence Rogers had been guilty of, particularly on one occasion, in a heavy gale of wind, when the strops of dead-eyes of the main rigging broke, and all the hands were ordered up to secure the mainmast; this skulking vagabond refused, until his captain went down to send him up, and then, like a lubberly scoundrel as he must have been, falsely declared he had been on deck all day, and was knocked up; what seaman, even in such a case, would have so excused himself when the mainmast was in danger?"

"An inquiry was afterwards held into the conduct of these men. Rogers declared he had a right to go overboard to bathe when he pleased, and that he took the belaying-pin to defend himself, suspecting it was the captain's intention to flog him.

"J. Maclellan declared if 'some people were put in irons, others must do their duty; to avoid which he would rather be a prisoner than do the duty of others.'

"Thomas Thomas was most insolent, declaring, if Rogers went into irons, he would be d—d if he would not go. This fellow had been guilty of theft, and pardoned upon promise of future good behaviour; being charged with this breach of promise by his present misconduct, he replied Captain W. H. Biden was as bad as himself, for not punishing him, and was most violent and contemptuous in his conduct.

"Maclellan was ordered to be suitably admonished; Thomas Thomas to be punished with three dozen; T. Rogers to be confined in irons, and delivered over to the civil power at the first English port the ship touched at. This mutinous fellow appealed to the ship's company to rescue him, to resist the captain's authority, and try which party was the strongest.

"My brother laid this case before the magistrates at Calcutta, who would not interfere in the matter, and observed that he should have flogged him at sea, and that he was vested with full power for so doing.

"On one point I fully agree with the magistrates, that such outrageous characters as Rogers and Thomas should have been flogged. I would advise every commander to punish, in the most exemplary manner, on the spot,

every daring attempt to dispute his authority, or excite, in any way, others to follow an example which may, by ill-timed lenity and forbearance, be followed by open mutiny. In the case I have described, the majority of the crew were well inclined, which induced my brother to stay the hand of severity; but how mortifying to submit to such contumely, and seek redress in vain, where we are told a remedy is always at hand, and where justice should ever preside."

We once witnessed a scene of a similar kind in a West Indiaman: the commander, who was an active naval officer, being treated with contempt by a kind of "twice-laid" sailor, as great a rascal as ever swung at a fore-yard, and not recollecting the eastern axiom that "a man should denounce no more than he can perform," threatened to clap him into irons: the fellow walked up, squared his arms, and with an aggravating tone and gesture, strengthened with such emphatic asseverations as seamen love to employ, bellowed—"bring them here! I'll throw 'em overboard, and perhaps you after them." Yet this blatant blusterer, who might have distressed a mild or weak commander, being firmly collared and well shaken, was instantly proved to be a spiritless bragadocio; and his insolence originated in the ill-defined extent of power which can be exercised in trading-vessels.

It is but just that the situation of master, on board merchant-men, should be so filled as to guarantee the proper fulfilment of any enactments which the government might be pleased to make. And reflecting on the command of a ship having been deemed, by maritime nations, an affair of such importance as to have been regulated by express ordinances, we have felt mortified at the disgraceful manner in which hundreds of our ships have ploughed the ocean. Where ignorance, incapacity, intemperance, and cupidity, are united in him who holds an *apparent* command, it is not unreasonable to expect the consequent degradation and demoralization of the seamen. With shame we confess to have met no such analogous absurdity among other nations. Examinations for estimating the qualifications of candidates for such appointments took place in Spain so far back as 1530, and in France from 1584. The Hanse Towns were also particularly scrupulous, for they not only demanded the proper experience, but also certificates of honesty and morality. Why then should England, the "gem of the ocean," be the only country where the too confident ship-owners are at liberty to make the dirtiest bargain they can, and place a needy lubber in a responsible and honourable berth? Formerly there was much more care in the disposal of these commands, and there were few English masters who were not *proprietors* as well of a portion at least of their vessels.

From the tone and temper observable on these pages, our readers will acquit us of being innovators, or partisans of wholesale reforms, whether brewed by saints or by sinners. Yet we are not so blindly jealous of the institutions of our ancestors, as to deem it sacrilege to improve whatever may be found bad; or to provide for present and future exigencies, with due regard to the policy of other powers, as affecting our security and welfare. While, therefore, we detail the inconveniences which necessarily result from the present mystified way of managing our marine affairs, it is with a view to taking effectual steps for removing them. This is a task of no common difficulty, and not to be accomplished by merely falling back upon the costly

ill-digested statutes of the Admiralty Court; for these, however partially adapted to the ages through which they have been endured, are confessed to be utterly unfit for grappling with the present state of commerce and navigation. As the arguments for furbishing up this farrago are more specious than valid, arrangements must be made, as sweeping as those by which Louis XIV. quashed the troublesome compound of quibbles and quiddities which debilitated the marine strength of France, when he politically gave his country an entire new body of mercantile and naval laws.

Authority and precedent are the avowed foundations of our Admiralty jurisprudence; yet new decisions of individual judges, grounded upon fanciful analogies to some former case, are constantly erected into maxims of law; and an adherence to remote sources of authority, in opposition to the plain standard of reason and common sense, involves every fresh question in inextricable confusion. While the stability of the law is relied upon in theory, its uncertainty in practice is notorious; and in fact, decisions depend more upon the personal character of the judge, than upon any fixed or ascertained principles. Thus right or wrong become subordinate considerations; the question is, not what is just, but what is *law*! and that law is not to be found in any written enactment, but in the ever-varying opinion of presiding judges.

When we hear ignorant men murmuring about "good old times," and the like, we hardly know what they are driving at, except that the simplicity of the cry creates a smile. Do they wish for the times of religious intolerance, of political persecution, of forced service, of burnings for witchcraft, of such trials and executions as those of Raleigh and Doughty? It is clamoured by some of the scribes of "the Press," on the topic in question, that the ancient Rules and Customs of the sea are quite sufficient for the well-being of the merchant service. We should be glad to know which of those "Rules and Customs" appeared to them so efficient. They could hardly mean the obsolete rigmarole for coasting craft, contained in the Rhodian and Oleron laws; still less can they allude to those of Wisbuy, or of the Hanse Towns, because they are mere fudges from the former. Few, we think, would desire the restoration of the discipline which, as the Harleian MSS. inform us, was prevalent in the golden days of Queen Elizabeth, when ducking, keel-hauling, beaching, and cutting off hands, were amongst the minor punishments; and when it was deemed propitious of fair winds, to have all the "shippè-boys" soundly flogged every Monday morning. According to this summary code, "If anye one slept in his watche, for the first time he was to be headed with a bucket of water; for the second time, he was to be haled upp by the wrysts, and to have two buckets of water poured intoe his sleeves; for the third time, he was to be bounde to the mayne-mast with plates of iron, and to have some gunn chambers, or a basket of bulletts tied to his armes, and so to remaine at the pleasure of the captaine; for the fourth time, he was to be hanged at the boltsprite with a can of beere and a biscott of breade, and a sharpe knife, and soe to hange, and chuse whether he woulde cutt himself downe, and fall intoe the sea, or hange still and starve." Here's a pretty alternative! Why modern black-listing, polishing, swab wringing, and diluting of grog—the cat—the rope's end—the bilbo—the scraper—the bear—the holy-stone—are to this as a mosquito-bite is to an ulcer!

SURVEY OF THE WEST COAST OF AFRICA IN 1825-6.*

THE harbour of Angola is very extensive, with a great depth of water. I should, however, recommend all European vessels not to anchor within one mile and a half of the town; for, as the nights are in general calm and oppressively hot, the sea-breeze becomes of the utmost importance, and by lying close under the island, it may be enjoyed with some degree of regularity. Numerous fortifications command the bay at every point. The strongest and principal garrison is situated on the brow of a hill on one side of the town, mounting nearly eighty guns. In addition to this are three others; one built on a rock communicating with the main land by a drawbridge, having also a very strong battery of sixty-four guns, commanding the harbour in every direction. The town of Angola is the most extensive settlement which the Portuguese possess on this coast. When approached from the southward it presents rather a grand and pleasing appearance, being situated on an eminence, surmounted by the garrison before mentioned. The houses are of stone, spacious and substantial, as Portuguese dwellings on this coast generally are; regularly and even tastefully built, with several churches and a cathedral. The market is tolerably supplied during the season, but filthy in the extreme. It is singular they do not take a greater pride in this one particular, for I believe, from the principal market-place of Lisbon, to that of their smallest settlement, they are noted for the dirty state of their towns, and the various offensive effluvia which they constantly inhale. Numerous military are stationed here; the privates composed chiefly of convicts from Portugal; many of the officers are also sent to this country for trifling offences committed at home. Two instances came to my knowledge, the one was *merely* for murdering a *padrè*, the other for putting a sister, who was a bit of a shrew, upon the fire, which was the natural cause of her becoming a cinder. For these *trifling* offences, being men of some interest, they suffered the penalty of transportation, and here appeared to enjoy themselves despite of *padrès* and sisters! Many of them are, however, most gentlemanly men and good officers, having served, in several instances, with our army when on the Peninsula. We invariably experienced the greatest politeness and attention from them whenever we were on shore.

Every description of provisions was at this time selling for the most exorbitant prices; even water is very scarce, on account of having no springs or rivers in the neighbourhood. In order to obviate this inconvenience, a number of large boats are constantly employed in fetching it from Bengo River, which is about nine miles to the northward, and upon them the town and ships depend entirely for their supply. We were informed that every description of tropical fruit was abundant here during the summer months; and the oranges are said to be finer at this place than any other along the coast. We had not, unfortunately, an opportunity of judging, in consequence of the rainy season having set in. The only thing we found at all plentiful were herrings, which our people caught so fast, that we were compelled to throw them overboard by boatfull. The zoological productions in the

* Continued from page 463.

immediate vicinity are lions, tigers, hyenas, wolves, zebras, and elephants, of a prodigious size. The soldiers have also some pretty horses of a Spanish breed. A great variety of serpents, scorpions, and numerous venomous insects bring up the rear, to give their gentle torments, if you be fortunate enough to escape the more ferocious violence of the larger inhabitants.

The unblushing effrontery with which the slave-trade is here carried on, surprises the unsophisticated eye of a European. The civilized inhabitant of an enlightened country naturally wonders how the sovereign of a Christian state can thus openly violate every tie of humanity and affection! The throne's lustre is tarnished by the tears of misery, and the King who countenances so inhuman a traffic, will tremble when called to receive that mercy which he showed to others. His hands will be too deeply stained by the blood of his victims, to hope that years of penitence and tears can ever wash it out! Is it not a stigma on the Powers which rule Europe, that they permit those who are compelled to obey, thus to obtain riches by breaking every law of religion and Nature? Twenty-four ships were at this time lying in the harbour of Angola waiting for cargoes of human misery. One brig, of not more than 180 tons, had on board above four hundred slaves, with which she went to sea! thus closely packed, to be tossed about probably for weeks, before they tasted the comparative, but sterile happiness of domestic slavery!

Having remained here for about a week, and completed a survey of the bay, we worked-out and proceeded to the northward. As we met with many contrary currents outside, and the wind was very light, we made but little progress for some days; this gave us an opportunity of observing the coast, which presented a particularly beautiful appearance, being thickly wooded, and varied with numerous hills, valleys, and rivers. We were led to suppose this line of country was plentifully inhabited, as every night we could perceive fires extending over a great distance.

About four days after leaving Angola, we arrived off a small place called Ambriz, where we found five vessels at anchor under Brazilian colours. This town is situated on a hill, which forms the south point of the bay, from which it takes its name: a reef extends some distance out from the land, affording good shelter for boats. This place is also supported by the slave-trade; and as there are no Portuguese inhabitants, the traders obtain them at a lower price than at other towns along the coast.

In the bay, a little above the town, is the mouth of a small river, which runs through a very extensive and fertile valley, presenting a most beautiful piece of scenery, the distant hills forming a rich and abrupt back-ground. Having passed the town of Ambriz, we came upon a very remarkable range of hills, covered with immense blocks of granite, looking, at a distance, like a number of large stone buildings, one performing the part of a church with much propriety, being formed by a large mass towering over all, in the shape of a modern steeple.

We passed numerous villages, which appeared thickly inhabited; from one we saw a boat standing off shore apparently full of people, and when she passed close under our stern, we found that she was loaded heavily with slaves. It appeared that she belonged to one of

the ships lying at Ambriz, where she was then going, having come from Kabenda, a distance of one hundred and twenty miles. These wretched beings had thus been exposed in an open boat for about ten days, writhing beneath a burning sun, without a particle of covering to protect their parched and ulcerous skins from the maddening bite of the musquito! We could only regret that we were not authorized to take them from their inhuman masters, and give them once more to their homes and liberty. The general face of this coast is a kind of red sand-stone cliff, from sixty to one hundred feet in height, parts of which are curiously excavated by the never-ceasing inroads of its boisterous assailant; numerous caves and fissures offer splendid accommodations to the various amphibious monsters that abound here. We frequently saw fires along the beach at night, probably with the intention of enticing us on shore, which is a very common custom on the east coast. The natives appear to live in a great measure upon fish, as a great many canoes were constantly seen near every village in the act of fishing.

As we approached the Congo, the water for some distance was much discoloured. This is caused by the body of that immense river running so far into the sea. We felt the effects of it several miles before making Cape Padron, which forms the southern entrance. When we hauled round the Cape, we found the current setting strong against us, which scarcely allowed of our making any way. Having tried in vain for some hours to get a-head, we were at length compelled to anchor, when we found the current was running past us at the rate of about four miles an hour.

On the following morning two boats were sent away, for the purpose of measuring a base line, and to procure soundings. The one in which I went proceeded towards Cape Padron: as we came near the land, we saw several Natives, who appeared greatly alarmed at our presence. We tried every means to give them confidence, but could not prevail upon them to approach, fearing we should seize and carry them off; a species of depredation which is frequently practised upon this coast both by the Portuguese and French. Their plan is to go on shore and mix with the natives, to whom they are apparently very generous, giving them in the first instance all kinds of trinkets and baubles; when they imagine their suspicions are removed, they introduce spirits, which they commence drinking, and soon persuade their intended victims to join in their revelry. The effect upon their unaccustomed natures is speedy intoxication, when their treacherous friends entice them to their boats. Returning reason finds the once free savage groaning in chains, with a mind torn by recollections of those ties of nature and affection, which are thus so violently and for ever broken! Hundreds are in this manner annually entrapped into perpetual exile and slavery!

We made another attempt to gain the entrance of the river, but although a breeze was blowing sufficiently strong to send us five knots a-head, yet we lost ground at the rate of about three miles an hour. The pinnace, which had left the ship at the same time with me, was absent the whole night, in consequence of getting into a current at the mouth of the river, which carried her to the northward at the rate of about six knots an hour. On the following morning she contrived to

reach the ship, all hands being in a state of great exhaustion from the constant labour to which they had been exposed.

For four days we made numerous attempts to enter the river with the sea-breeze, and were as constantly drifted back to our starting place. On the fifth, the wind having increased, we contrived to get within half a mile of Shark Point, which forms the southern entrance, where we continued under all sail for several hours, during which time we did not get one inch a-head; and, as the wind was falling, we were compelled, in order to keep what we had gained, to come to an anchor. On the following morning, as the sea-breeze set in strong, we got under all sail, and in about six hours rounded Shark Point, where we found the water quite fresh; then proceeded slowly up the river, sometimes within twenty yards of the shore, in eight or nine fathoms. The width at the mouth is about three miles and a half, but it gets rapidly narrower upon ascending. A quarter of a mile off Shark Point we tried soundings with two hundred fathoms line without finding any bottom. After passing this point, the coast on both banks is composed entirely of mangroves, with the exception of a few sandy bays up some of the numerous creeks on the south side of the river. Before coming to an anchor, we observed a schooner lying about two miles higher up, under Portuguese colours. In the evening a boat was seen a short distance from the ship, with four black men in her; upon being hailed, one of the party said they were going to Kabinda, a distance of forty miles. Immediately after answering, they begged permission to come on board, when we found, by a few interrogatories, that she was a Portuguese boat sent by the above-mentioned schooner for the purpose of discovering our character and intentions. It appeared that she was in great alarm respecting a pirate, under Spanish colours, which had lately been committing devastations upon the slavers by coming up the river, when they had got a cargo, and robbing them of their slaves;—a species of piracy which, according to report, appeared by no means of uncommon occurrence upon this lawless coast. It forms a strange anomaly, that these spoilers should thus again be subject to the attacks of others so soon as they have obtained their prize—like the ferocious hawk, preying upon the smaller birds of the air—and immediately afterwards becoming himself a mouthful to the lordly eagle.

On the following morning, as we were taking in wood and water, for which this is a very convenient place, several canoes came off with numbers of inhabitants. The costume of these people was entirely that of our first parents, with the exception of some of the *nobility*, who have picked up an occasional jacket. This they wear without any other garment than the bunch of leaves or old piece of dungaree round the middle. These are, perhaps, the most superstitious savages to be met with, relying almost entirely upon their charms for the success of every event of their lives. They are all abundantly supplied with them, and if they find one will not produce the desired effect, they substitute another, *until the effect is produced!* These creatures thought we admired their mode of conducting the ways of Providence, and wondered how "white man," who, they say, "is very big in all things, no make Feteish!" They are a fine race of blacks, but I believe very treacherous. Their strongest attachment appears to be towards

brandy, and I firmly believe any one of them would sell his whole generation for a single bottle of that stimulating cordial. Several of them speak broken English, which they have picked up from the trading-vessels touching here, and mentioned, amongst other topics, the ill-fated expedition of Captain Tuckey, in His Majesty's ship Congo.

Some of the chiefs, upon coming on board, and having a little brandy given them, seemed to consider it in the same light as the Arah does his salt, and insisted upon our firing a gun to let all around know that we were friends, and come, as they expressed it, "to make trade," under the impression that we intended trafficking for slaves. The gun appeared to be well understood, for immediately afterwards numbers came on board. Their first request was always for a little brandy, which, if complied with, was sure to be followed by "a little more," until David's immortal saw would have been a sober brute by the side of these. When given to understand that we intended proceeding up the river upon the sea-breeze setting in, one of them stood forward and said, that he would immediately bring the wind for us, (having, I suppose, previously observed that it was coming,) at the same time wishing to know whether we should prefer a gentle breeze or a strong one; having received some description of answer, he immediately mounted the poop, and took out one of his Feteish, or charms. He then gave several loud blasts, throwing his arms about in the most violent manner; then paused for a few minutes, standing in the most ridiculous attitude, when he commenced expostulating warmly with Mr. Feteish for not obeying his first commands. His stony-hearted hearer was not, however, to be bullied out of a breeze; this our interceder determined to turn to his own advantage by requesting a little brandy to coax him into good-humour. Upon our indulging his whim, it was highly ridiculous to see the vagabond take a mouthful, and go through all the motions of spitting it on his charm, taking at the same time the greatest care not to expend more than one drop upon the obstinate Feteish; who, in spite of his eloquence and liberality, would not exert himself in our cause. Having continued this mummerly for some time, and finding no more brandy was to be obtained, he left off his incantations, with an assurance that the breeze had been sent for, and would shortly be with us. Patience fortunately did more for us than the antics of the savage, and in an hour or two we obtained the requisite gale, when we proceeded up the southern side of the river to a place called Scotchman's Nose, a distance of seventeen miles.

Monkeys are extremely numerous at this place, each of the banks being a perfect colony of these intellectual brutes, who here shine in society by comparison with their human relatives. In many instances, I have seen more sagacity displayed by this animal, than the other natives of the woods which they inhabit; they keep a day and night watch constantly on the look-out, who, immediately upon any stranger appearing in their domain, gives a signal to all friends and relations to be on the *qui vive*! When this has been given, it becomes a most difficult matter to see one, although they can be heard around in every direction, and an occasional pair of eyes, or hit of a tail may be seen peeping from behind some neighbouring branch or tree. Having the organ of

"*destructiveness*" very prominent, I was induced upon one occasion to shoot at an impertinent fellow, who, I could not help thinking, had been amusing himself at my expense quite long enough, chattering on each side of me without my getting a glimpse of him during the whole of my walk. At one unlucky moment, he appeared before me with a most malicious grin upon his countenance, when I levelled my gun and fired; immediately after the report, I thought all the imps of darkness were rebuking me for my cruelty, by the various discordant sounds which broke out on every side. When silence ensued, I heard gentle wailings of so pitiable a description, and so much like those of a human being, that it was some time before I could convince myself I had not wounded one of my boat's crew. At first, I thought the unfortunate little object of my aim had escaped from the fate which I had intended him, when, after a slight effort to retain his hold, I observed him fall to the earth from the bough on which he had been perched. Upon going to the spot, I found the wounded animal moaning in the agonies of death with a hand placed upon its bleeding side. When I approached, it did not attempt to move, but fixed a large pair of eyes upon me with a look which I never shall forget, and I thought, pointed to the wound, as if to reproach me for the act. As the appeal came home to my feelings, and the poor little victim of my cruelty appeared in great pain, I sent another ball into its head to end at once its sufferings, and then turned from the spot, leaving the lifeless little body with a determination never again to amuse myself at the expense of humanity.

Wild parrots, and many other birds of beautiful plumage, are here found in great numbers, a few of which we procured.

Upon arriving at Scotchman's Nose, two boats were dispatched; myself in the gig to survey the southern shore, and Lieut. Boteler in the pinnace to Cape Palmeiro, which forms the northern entrance of the river. The breadth at Scotchman's Nose is not more than one mile and a half, with rather shallow water. As the weather was fine, and the Barracouta had dropped down with the stream for the purpose of taking soundings, at sunset I anchored my boat about two hundred yards off shore for the night, and in the morning continued the survey. We entered a small river to breakfast, where we observed several canoes making for the opposite side, in evident fear at our approach; they got quickly to land, and leaving their boats on the beach, took to the bush, where they resisted all our attempts to draw them out. On leaving this river we met another of our boats, which had been sent to assist me in the survey.

Going on board in the evening, I was much surprised to hear that the natives had attempted an attack upon Lieut. Boteler and his crew, particularly as they are in general considered very docile and friendly upon this coast. It appeared that when near Cape Palmeiro, the pinnace, whilst running along shore, got into shoal water, and shortly afterwards took the ground, when they had some difficulty in getting off. The inhabitants of a small creek just by, observing her so close in, and some apparent confusion existing, immediately took to their canoes, and in a few minutes about thirty of them, mustering in all one hundred and twenty men, came round the point of the creek, pulling with great velocity towards the boat; fortunately for her, she

had by this time contrived to gain deeper water, as, when just within musket-shot, they set up a most horrid war-whoop, and dashed on nearly in a line towards the pinnacle. Lieut. Boteler by this time had no doubt of their hostile intentions, and desired his men to fire a volley of musketry over their heads, as a kind of notice to quit; this, however, produced no effect, and they still continued pulling on, upon which he fired another volley; this producing no more effect than the former, and as his small party, only twelve men, would have had no chance at close quarters against their numbers, he ordered a long one-pounder to be fired at them; this appeared to *astonish the natives* amazingly, and they began quickly to disperse, a few only continuing their course, but a musket or two soon produced the same effect upon them. To secure their retreat and prevent a rally, the long gun was again fired amongst them by way of farewell, which intimidated them so effectually, that they all pulled towards the shore with the utmost speed. It was fortunate they were so easily disheartened, as had they got alongside, their increasing numbers must ultimately have overcome the boat's crew, and a general massacre would have been the consequence. As neither their *Morning Post* or *Gazette* ever mentioned the loss sustained, we had no opportunity of learning what execution our guns did amongst these hostile savages; but as our men were well practised in the use of their arms, they no doubt got a lesson which may prove serviceable to European ships visiting this coast in future. In justice to our Commanders, I must here state, that we had the most positive orders never to fire a shot at the natives, unless the most urgent necessity required it. This principle of humanity was strictly attended to; and I feel confident in stating, that during our constant intercourse with these ignorant and generally treacherous savages, not one drop of blood was shed which was not justified by self-preservation.

Numerous islands are seen constantly floating down the Congo, some of which have rather a picturesque appearance. They are formed by mangrove bushes and other loose trees, which collect upon the banks, and are then carried away by the rush of water, which generally takes place after heavy rains. The inhabitants of the upper part of the river make use of these by fastening their canoes to them, when they gain an easy and expeditious passage down at the rate of six or seven miles an hour. Vessels on this coast are frequently deceived with regard to their situation by these apparent islands, which sometimes drift a long way to seaward, at the same time they serve as guides to those who are acquainted with their situation, and from whence they come.

It is extremely difficult to get any provisions at this part of the river, the natives are in so miserable a state of poverty; if you can persuade them to procure some, two or three days must elapse before they can be obtained. The principal rendezvous of slavers is a place named Talltrees, situated about forty miles up this river.

H. B. R.

(To be continued.)

ON THE STATE OF EFFICIENCY OF THE BRITISH ARMY.

THE existing and relative state of the several powers of Europe, and the vast armaments of France called into being by a government neither fixed in principle nor consolidated as to power, if they do not importunately demand an increase of our army, must yet imperatively dictate that its organization should, to the extent of its numbers, be complete; that it should possess the utmost possible facility of expansion on an emergency, and that our navy should be adapted to render abortive any aggression on the part of an enemy on the first ebullition of hostilities. In this view, the remarks of the *United Service Journal* for the month of March, on the application of steam as the propelling power to ships of war, and the observations of a correspondent on the organization of the British artillery, must be admitted as important; still, farther discussion on these points may be admissible; as much, far more than can now be offered, remains to be said on either subject.

The present organization of the British infantry leaves little to desire; the reserve companies of regiments on foreign service (though the system for certain reasons is liable to objection) are admirably calculated for facilitating the formation, in the least possible time, of as many battalions; the number of officers required to render them complete being easily obtained from the half-pay. Under experienced officers, and with a nucleus such as the reserve companies afford, a few weeks would render recruits respectable and efficient infantry. But cavalry, whatever be its organization, however ample the means at its command, both as to men and horses, requires considerable time to derive from an extension of its numbers a corresponding accession of strength. A dragoon when complete in his drills as an infantry soldier, has still to be instructed in the sword exercise, to be made a good groom and an expert horseman; his horse, too, requires to be brought into condition, and to be trained for the purposes of war. The British cavalry, to the extent of its numbers, may confidently face the best cavalry in Europe, but it cannot be hastily augmented. An opinion may be hazarded, that the horses, generally speaking, are too aged, and it is perhaps to be regretted, that breeding studs under military control do not exist; the general application of steam to public carriages would probably compel the adoption of that measure.

Since the sudden creation of efficient cavalry is from its very nature impracticable, the want of it can only be remedied (as it ever has been by able generals) by a numerous, well-appointed, and highly instructed artillery; such an artillery as Great Britain cannot now bring into the field, but which she, in limited numbers, possessed at the conclusion of the late war. At that period, the British artillery was admitted by all foreign armies to be the first in Europe, both as concerned its *matériel* and *personnel*. The officers might, perhaps, be best judged of by the efficiency which their arm had attained. The gunners were the finest body of men in the service, and never failed either in zeal, activity, gallantry, or devotion to their officers and to their duty; they were intelligent in a degree which no other branch of the service had ever attained; their *esprit du corps* could not be exceeded; they were not less remarkable for their admirable bearing in the field, than for their orderly and respectable conduct in quarters. The drivers were a class of men particularly fitted for their duties; they were gallant soldiers,

their intrepid stoicism under fire was often the admiration of every branch of the service, they were admirable grooms, light weights, (a matter of infinite importance,) and as to the degree of skill which they had acquired in the management of their horses in the field, no soldier of a similar class in any foreign army ever came near them; indeed, the construction of the limbers of the British artillery admitted a rapidity in any change of direction, and a celerity in limbering up, which, in superseding the prolonge used by the artillery of other nations, afforded all the opportunity a driver could desire for evincing superior art. The horses of the British artillery were worthy of the nation which had long been pre-eminent for the superiority of its private studs and its attention to this breed of animals. The uniform construction of its carriages, their strength and simplicity, the harness and horse appointments were all unrivalled in Europe; its general superiority was such as to have been closely imitated by the French. The ammunition, and the manner of making it up and packing it, were in many respects superior to the modes adopted by other armies; its spherical case shot, imagined upon a principle which, if not scientific, is yet so ingenious as to have baffled to this day the inquiries of the French, though they have often recorded its effects in the day of battle, may be noticed. Without entering at greater length into the subject, it may confidently be asserted, that at the close of the war, which pinioned the arms of the greatest General the world ever saw, the British artillery, though in proportion to the other arms in the same service numerically inferior to any in Europe, was yet in quality superior; so said the Austrians, so said the Prussians, so said the French.

“ ——— Qualis erat ! quantum mutatus ab illo
Hectore, qui redit exuvias indutus Achillis.”

The reverse of the picture is painful.

As to the officers of artillery in the present day, though part of the old stuff still remains, and may yet be roused to energy, it is to be feared that ΜΕΝΤΩΝ, in the March Number of the U. S. J., adhered but too rigidly to truth, when he asserted “ that the prospects of their profession are so had as to make them as nearly as possible indifferent to its study or practice.” As to the old gunners, they are for the most part gone, the drivers entirely so, and instead of the athletic, proud, and intelligent race afforded by the first, and the light, active, and efficient body by the latter, an amalgate or amphibious genus has arisen, possessing none of the qualities of the other two in any degree of perfection. The present artillery soldier knows his inadequacy to perform well all that is required, and therefore feels degraded by the mass of heterogeneous duties forced upon him; the appellation by which he is now mustered, (*gunner and driver*), has gone far to eradicate the most desirable pride of a soldier. Indeed, if it be deemed essential that the appellative of the artillery soldier should describe the duties heaped upon him, or rather convey an idea of his multifarious employments, he should, for some time since, have been termed *gunnero-drivero-waggon-trainero-infanterist*.

The horses of the corps were, with the drivers, annihilated at the peace, six hundred being retained out of fourteen thousand; it will be long before the utmost care and the most lavish expenditure could in any degree, in this respect, replace the artillery on the footing of

1814. The *matériel* remains the same, or has in some respects, particularly in the howitzers, been improved; but what energy, what devotion, can, under the present system, animate this inert matter? The only attempt which could fairly promise any beneficial result would be to *hark-back* upon old times, a measure directly the reverse of that which would be resorted to in seeking improvement in any other art or *métier*. But this resort must fail, for though the officers (the springs and sinews to animate the matter) remain, they are, alas, for the most part, withered and grown old, or such an excess of superannuation is visible, as must paralyze the renescent efforts of the few. On this subject, see a work published some years since, entitled "Remarks on the promotion of the officers of artillery, and on the application of that arm in the field."

MONTON would advise, as a panacea for the deep-seated and long standing disease of the artillery, which has existed independent of the aggravating causes arising from the change in its organization, the purchase of commissions and the removal of superannuated officers. A long, intimate, and attentive observation of the machinery of the corps would lead to the belief that the most threatening symptoms would be palliated, and the difficulties soon removed, if the artillery were withdrawn from the control of the Ordnance Office, and placed under the direction of the Horse-guards. No rivalry would then exist, the jealousies which operate so materially to the prejudice of the artillery would vanish. The Commander-in-Chief, for his own sake, as well as for the interest of the country and the reputation of the army, would adopt measures which are within his grasp, that the efficiency of an arm so important may be preserved. The corps of engineers, being so constantly employed on works connecting them with the Ordnance, might continue subject to that Board; but it is difficult to imagine a reason why the artillery should be denied that wholesome control and that fostering care which the Commander-in-Chief of the army can alone afford; that they employ vast quantities of stores, the particular charge of the Board of Ordnance, can be no sufficient reason; the responsibility of the artillery officer would be the same, although placed under the Commander-in-Chief. An army, to be efficient, must consist of the three arms, each in a corresponding state of discipline, and in proportionate numbers; identity of management and unity of interests should pervade; it is inseparable from perfection.

The ever-to-be-lamented Duke of York, and the highly gifted Duke of Wellington, acting in the spirit which can alone render the artillery efficient, afforded great facilities for the removal of officers of artillery to other branches of the service, and if the offers which were made to the artillery officers on the augmentation of the army in 1825 were not more generally accepted, it can only be attributed to the comparative backwardness of their rank, which would have deeply told on joining other regiments, and to the novelty of the proposal.

Of the many advantages which the country would derive from the union of the artillery to the administration at the Horse-guards, relief from the expense of two Military Colleges, when one would more effectually attain the object for which they are designed, may be named. Cadets selected for the artillery service, after completing their studies at Sandhurst, may be sent, previous to receiving their commissions, to Woolwich, to be instructed under the superintendence of an officer in

the practical and peculiar parts of their intended profession; they might go through what is commonly termed a *repository* and *laboratory course*; in the one, the use of all engines employed by the artillery, the application of mechanical powers to the necessities and difficulties of artillery, and the construction of batteries and bridges, are professed to be taught; in the other, the mode of preparing and making up the several fire works and ammunition used in the service. Cadets leaving the Military College for the engineers, may complete their education at Chatham, and on the military survey of Great Britain. The course of instruction at Sandhurst is well designed, but perhaps practical mechanics, chemistry, mineralogy and geology, may with advantage be introduced as another step from which a cadet may select the number entitling him to a commission, and this may be made essential, as well as the second, or perhaps still higher step in mathematics, to the acquirement of commissions in the artillery and engineers. As to the practical use of guns and mortars, so little time is necessary to devote to this exercise, when a cadet is once drilled as a soldier, that all the cadets at the College may be beneficially required to attend to it, and for this purpose an officer of artillery should be attached to the establishment; a non-commissioned officer can scarcely be expected to blend the necessary science with practical instruction, when it is considered that the exercise of artillery may for the most part be referred to the laws of mechanics; and its practice at a target to some of the most refined and elaborate researches of the best mathematicians of the day.

Again, recurring to the existing state of the artillery as affecting the question of the general efficiency of the army, it must be admitted that the horse artillery is the only part which can be deemed efficient. This corps, too, is not what it was; the disease, which is endemic in the artillery, has here made great ravages; it may, however, still bring into the field EIGHTEEN guns!!! The field artillery is actually incapable of turning out a single battery at all on a footing with those of olden times: the organization is defective, the system inefficient, and neither does or can work satisfactorily. As to expansion, according to the present efficiency of the artillery, it certainly possesses that property; for as the fiat of a superior, and expediency arising from an *extravagant* economy, is made to supersede the necessity of good riding, driving, and grooming in a driver, or target practice in a gunner, it may also render unnecessary the condition and training of horses, and the happy *ensemble* which has hitherto been deemed essential to perfection in a machine composed of so many complicated parts as a battery of artillery; but can such an artillery, by the rapidity of its movements and the ubiquity of its fire, make up for the want of a numerous cavalry? Could it support and give confidence to the newly raised regiments of militia, and of other less regular forces, if suddenly called to the field. This duty hitherto has not happily been the lot of the British artillery, but the 300,000 infantry, the 65,000 cavalry, and the 1200 field guns of the French, with their recent establishment for steam-vessels on the Loire, certainly would indicate the necessity of preparation without the tannt of M. Manguin in the Chamber of Deputies, adverted to in the recent Number of the Journal.

On steam-boats and their armament it was intended to offer some observations, but the length to which the preceding remarks have extended, at present forbids our entering on the subject; we may recur to it hereafter.

ON THE ORGANIZATION OF THE BRITISH ARTILLERY.

NO. II.

IN my last Essay on the Organization of the British Artillery, I proposed that each company should become an independent corps, containing within itself all that is necessary to its discipline and efficiency. I consider this to be the organization which results *naturally* from its service, which is the simplest, the cheapest, and the most applicable to all its varieties of duty.

There are some principles which, as it appears to me, should always be strictly attended to in the formation of all military bodies.

First, each regiment, or integral part of an army, *must be under the uniform command of one man, interested in its good appearance, efficiency, and success, who must be responsible for his charge, and removable when not found equal to his duty.*

Secondly, its size should not be too great to admit of his personal inspection and superintendence, under all the circumstances of its ordinary situation, *so as that he may be thoroughly acquainted with every officer, and generally with the men.*

Thirdly, promotion should be confined, as much as the interests of the service will permit, within each regiment, *so that those who share equally in the perils of any duty, should also share equally in the advantages resulting therefrom.*

Fourthly, this promotion should be at such a rate as to prevent men arriving at commands requiring much energy and exertion, only when they are in mind and body too much debilitated for either.

In conformity with the first principle, I make each company of artillery an independent corps, with its captain as its commanding officer. The second principle seems equally to require the same system of organization. The third principle can scarcely be uniformly acted upon but under this system. The fourth principle seems to require one of two methods of pensioning off superannuated officers: either that of making them a permanent charge on the pension-list of the country, or of furnishing them with the means of retirement from the private purses of those who succeed them. This last method could only be introduced gradually, *as no officer, having entered the service on the principle of promotion by seniority, could be reasonably called upon to purchase in order to prevent a junior passing over his head. In the first instance, and until the corps be filled by officers who have entered on the principle of purchase, the money of those who buy commissions must be thrown into a common purse, to aid in pensioning off those whose retirement should be required by the service.*

In a subject so speculative as that of the proposed new organization of the artillery, an attempt to trace some of its probable consequences may be allowable. In the first place, the greatest possible emulation, and the highest state of military appearance and discipline, may be expected to result from it. Each company, distinguished by its number in large characters on the ornaments of its chako and appointments, would become known for its excellence in some or many respects; or, otherwise, as the case might be. The actions also in which it had figured might be commemorated, and their names be borne upon the appointments of the officers. A high character, once obtained by a company, would, as in the case of the crack regiments of infantry, be not easily lost, and care would be taken to maintain that character by the selection of officers to command it. Its instruction also, as well as its appearance and discipline, would be advanced by the anxiety excited in companies to rival each other in the estimation of those officers entrusted with the various branches of instruction.

In the second place, every defect would be more obvious, its cause more immediately discerned, and more easy of cure.

In the third, an equipment for active service would become much more simple and ready. The artillery part of each company being always in a state of the highest completeness and perfection, it would only remain to

attach to it from the depôt, the drivers and horses necessary to its field establishment, and the field battery would be complete. The detachment of drivers so told off to companies should consist only of non-commissioned officers and drivers. The officers of drivers should always remain with the depôts. As during peace, some companies are placed to the field service for instruction, and note is taken of those which have been qualified for it, there are always some ready for immediate service.

In the fourth place, every improvement in the equipment and arming of the artillery soldier, would be more likely to suggest itself from the emulation excited by the new system, and would be more easily tried from the small size of the corps to which, in the first instance, it might be applied.

The separating the gunner from the driver would have two desirable effects. First, each man could by the recruiting parties be obtained good of his kind, and suited for his particular service. At present, there is at least a tendency to introduce only an inferior style of men to perform both duties, without being well qualified for either. Secondly, the duties both of gunner and driver would be much better performed than they can be at present.

By bringing all the recruiting service under the management of a Board of officers stationed at head-quarters, this might, perhaps, be conducted at less expense and with more advantage than it is at present by independent battalions. In every way, it appears to me that the organization by battalions is no more suitable to the artillery than it has been found to be to the sappers and miners.

Having thus concluded my observations on the organization of the British Artillery, I have only to remark farther, that whatever may be their reception, whether they be considered wise or foolish, feasible or not, they seem to result legitimately from principles, whose truth appears proved by the system and practice of the British Infantry.* They seem to result as naturally as do the operations of Nature from its laws.

MENTOR.

* The present system of battalion organization in the Artillery is probably intended as an assimilation to that of the line, but the nature of the Artillery service, in its necessary distribution and movement by companies, is not analogous to that of the line, and the organization of the latter is, therefore, faulty when applied to the former. In like manner, the manœuvres of field artillery, in which each gun of a battery of six or eight pieces may be the pivot of movement, or the point of formation, cannot be reasonably conducted upon a system minutely copied from the manœuvres of infantry, in which every file of from three to four or five hundred may be a pivot upon which to turn, or a point to form upon. There is not the same intricacy, the same danger of confusion, and consequently not the same occasion for the strict preservation of relative situation in the one case as the other. A battery may come into action to the rear, and by so doing, make that gun which but just now was the right, at this moment the left gun of the battery. The change in the arrangement of the parts of the battery is so quickly and clearly to be seen, that it is of no importance: the right or left flank is that which is so at the instant of command, and on this principle manœuvres may be conducted much more rapidly and easily than on any other; and which is a great desideratum, their number may be as few as possible; not so with the line. These are instances in which to endeavour to assimilate the services is, in reality, to act upon different principles in regard to them: it is to study utility and the fitness of means to their end in one instance, and to forget them in the other. So, if it should be proposed to reduce the proportion of officers to men in the artillery to the standard of the line, it would only be necessary to show the nature of the artillery service to prove that such a proposition rested upon an erroneous notion of analogy between the artillery and the line. In the artillery a small detachment of men often has charge of very extensive and important stores and magazines, besides batteries. In this case the necessity for the superintendence of an officer is, not only, as in the line, founded upon the number of men under him, but also, and much more, upon the quantity of material in his charge. In the field service the charge of horses is also added to that of material, all of which, to a person acquainted with the service, shows a necessity for a greater proportion of officers in the artillery than in the line.

A NARRATIVE OF THE LATE DISASTROUS VOYAGE OF
THE H. C. S. BRIDGEWATER. 1829-1830.

BY AN OFFICER OF THE SHIP.

CONSIDERING the almost unparalleled extent of the disasters that befell the H. C. S. Bridgewater on her late voyage to India and China, and, from her having been so long missing, the anxiety that must have been felt by many, who, either from family connexions or commercial speculations, were interested in her safety, it cannot be but a matter of surprise that no detailed account should as yet have found its way to the public. In order to remedy this deficiency, (however incompetent to the task,) I have been induced to draw up the following statement, conceiving that a faithful record of the events attending this disastrous voyage may not only prove acceptable to those connected with the ship, but likewise be perused with interest by the general reader. The circumstances attending the accidents that befell us during the former part of the voyage, are not, perhaps, sufficiently marked either by novelty or incident to justify a minute detail; I shall, therefore, rapidly glance at them, and then proceed to give more copious particulars of the hurricane which we encountered off the Isle of France, when homeward bound,—a hurricane which, judging from what I have heard and read, I believe to have been unexampled either in duration or violence. The effects of it on the ship have been manifested by her subsequent condemnation, and nothing, I am convinced, (under Providence) but the adoption of every precaution which judgment or experience could suggest, to put her in a state to sustain the reiterated shocks, enabled her to survive it.

The misfortunes of the Bridgewater may be said to have commenced from the time of her leaving England; not a week had elapsed, when, in a violent squall, she lost her mizen-mast; this was, however, speedily replaced, and with the exception of a very heavy gale of wind of twenty-four hours' duration in Latitude 19° 00' S., Longitude 84° 00' East, we may be said to have had a very fair passage to Bengal.

After completing our lading there, and attempting to sail, we were subjected to some of that dreadful weather which is so often experienced off the sandheads in the south-west monsoon, and having lost three anchors, we were obliged to put back to await the result of the next spring tides, when we succeeded in getting to sea. Things now went on well until our arrival in China, when, in consequence of a misunderstanding between our Government and the Chinese, we received orders to make sail for Tonkoo Bay, instead of proceeding to the usual anchorage at Whampoa. In carrying these orders into effect, we were overtaken by a most violent typhoon. We had anchored the evening before, the weather fine and the wind light, without any appearance of a change: as the night advanced, however, the sky assumed a very squally and threatening aspect, and before daylight appeared, we had our lesser yards and masts on deck. The wind now increased in violence, and soon blew with great fury. We soon perceived that the ship was driving, and although every exertion was made to bring her up, by letting go other anchors, it had no effect, and when close on the edge of Lintiu Sand, we were obliged to cut away our masts in order to

save the ship. For a ship in such a situation, no country possesses fewer facilities for remasting and refitting than China, both from the scarcity of wood and stores. Accordingly, in carrying this into execution, we had the greatest difficulties to contend with, and which nothing but the most determined activity and perseverance enabled us to overcome; whilst this was in progress, we had been at the Whampoa anchorage alone, and, therefore, little or no assistance could be given us by the other ships, which were still detained in Tonkoo Bay, the disagreement with the Chinese not being yet settled. Immediately as the ship was in a state for moving, we were ordered to rejoin the fleet. On our arrival we found that it had been determined to send home one of the ships with despatches, and from the priority of our arrival in China, we were selected. We were now the envy of the whole fleet, and we ourselves thought that it was, in some measure, a compensation for the difficulties which we had before experienced; but Providence had ordained it otherwise; and five weeks after our departure from China, having advanced as far as the twentieth degree of southern latitude, the poor Bridgewater was retracing her steps to India, a perfect wreck, not, however, without having given indubitable proofs that she had originally been as fine a ship as had ever been put together by British artists.

We left China on the 1st of February 1830, and could the good wishes of those whom we left behind have availed, we certainly should have had a most delightful passage. We had several passengers, many who had taken their passages in other ships, but who, from having been detained six months in China, had become heartily sick of Macao, and were glad to avail themselves of the opportunity now offered. Every thing went on smoothly until our departure from the Straits of Sunda, when our troubles may be said to have commenced. For the first eight days we had nothing but light winds and calms, the annoyance of which may be easily imagined. For some days after we had frequent hard squalls from the north-west, with heavy rain. This circumstance, from its being very uncommon in those latitudes, together with the state of the atmosphere, which was of the most dense and close description, impressed Capt. Manderson with an idea that something very unusual was about to happen: how abundantly this was verified, the subsequent account will amply testify. On the 4th of March the hurricane may be said to have commenced, for although on the previous day we had reduced our sails, and got our top-gallant yards and masts on deck, yet it was nothing more than what seamen might term a fresh gale. On that day, however, the barometer still falling, and the wind increasing in violence, indicated something serious, and here I feel that I cannot convey a more clear or perspicuous account of each succeeding event, than is recorded in log of the different days.

“ March 5th.—Got the jib-boom and spritsail-yard in. Throughout a very strong gale from the eastward, with violent gusts and heavy rain; the ship taking a great quantity of water on board, and labouring very deep. Hove-to under the trysail until midnight, when it was blown to pieces. Continued hove-to under bare poles. Got the fore-tackles forward, and secured the fore-mast and extra tackles on the main-mast and lower yards. 3 P.M. Hove three of the quarter-deck guns overboard. At midnight, barometer still falling, cut away the sheet and stream anchors, and started the water

on the gun-deck. At 4 A.M. a sea struck the ship, and carried away the quarter-boats; the pumps fore and aft constantly working to keep the ship free.

“Saturday March 6th.—These twenty-fours commenced with a violent hurricane, a north-east. The sea too high to allow the ship being steered. Continued hove-to under bare poles, with hammock cloths in the weather mizen rigging to keep the ship to the wind. P.M. The ship labouring very deep, and taking on board immense quantities of water, cut away the small bower anchor. At ten a sea struck the ship, and washed away the starboard-quarter galley. At midnight the barometer still falling, and the appearance very threatening, the pumps barely keeping the ship free, with sometimes two feet water in the hold. Daylight dawned without any prospect of a change, and the ship not keeping to the wind, cut away the fore-top-mast, which we considered made the ship a little more easy. At noon, still shipping much water, and every prospect of a dreadful gale.

“Sunday March 7th.—The hurricane still blowing with the greatest fury, and the sea rolling constantly over the ship, having washed away the hammock nettings and some part of the bulwarks: the hatchways all battened down with tarpaulins and extra hammock cloths. The ship now a complete wreck, and the ship's company nearly exhausted, having from the commencement of the gale worked with the greatest cheerfulness. It was now evident that unless an alteration took place in a very short time, the ship must founder. The greater part of the people at the pumps, and using every exertion. About four P.M. the main rigging went, and the mast rolled over the side, taking with it the head of the mizen-mast and crossjack-yard. About this time the violence of the gale appeared to abate; by eight it was decidedly more moderate, the wind during the night having veered to north-west. Found the ship had strained and suffered severely in the hull; still obliged to keep the large pumps going; found that the tiller was very loose in the rudder-head; too much sea on to repair it.”

From this statement it will be seen, that we had abundant reason throughout to dread the consequences, but for my own part I had no serious apprehensions as to the result until the afternoon of the last day, when, however, I found that at that time the violence of the hurricane did not abate, and that with our utmost exertions at the pumps, we could not keep the ship free, and that in consequence of the immense quantity of water in the hold, the teas had become so saturated, and acquired so much additional weight, as caused her to labour exceedingly, and tremble at every successive shock, occasioned by the tremendous seas that struck her, as if it were the last that she could possibly sustain. I confess that all hope of ultimate preservation entirely left me; to our being efficiently prepared in every possible way, for the hurricane, can alone be attributed (under Providence) our unexpected deliverance. Had we been less so, or had had any heavier cargo than tea, I am firmly persuaded that the consequences would have been fatal. With the exception of a little biscuit and a glass of spirits occasionally, not a man in the ship had, throughout the three days, either sustenance or sleep. Owing to this, together with the great exertions required of them at the pumps, they had become completely exhausted and dispirited, and at length betrayed an utter indifference to life. One of my messmates at this time said to me, “How dreadful this uncertainty is! I wish the crisis was come.” My feelings accorded with his, for I fancied that a prolongation of our lives was only a hopeless protraction of our miseries and sufferings. When the main-mast was blown over the side, I was near the cabin to which the ladies had been removed

for safety, from its being less exposed, their own cabins having been rendered uninhabitable by the sea making through them direct breaches; never shall I forget their piercing and heart-rending shrieks. The blast that assailed us was most awful, and the tremendous crash and uproar caused by the falling of the masts, led one to imagine that all was over. Who can but feel for females in such a situation? and yet how constantly in times of extreme emergency do they exhibit the most heroic fortitude.

Throughout the gale they had no occupation, as we had, to divert their attention, nothing to employ their minds but the horrors of the situation in which they were placed, and yet never to the last did I hear a murmur escape them. Well may they be said to be a succour and comfort unto man. The main-mast and part of the mizen-mast having gone over the side, and the wind, having as it were attained its utmost degree of violence, and exhausted on us all its fury, becoming apparently satiated with the destruction which it had occasioned, gradually subsided, and the morn discovered the Bridgewater a complete wreck, her yards and masts (with the exception of the foremast) over the side, the bulwarks all washed away, all our live-stock drowned, and every thing bearing ample testimony to the contention that had been sustained with the boisterous elements. It was indeed a melancholy and appalling sight, and nothing but a feeling of thanksgiving to the Almighty for such a miraculous preservation, could have reconciled one to a calm review of such tremendous havoc.

On looking back and reflecting on the events that had occurred in this dreadful period, a recollection of the thoughts that agitated one's mind, acquires a peculiar interest. One circumstance in particular made a more than ordinary impression, and although it may appear unimportant in itself, still I hope that I may be pardoned for having entertained for a moment a superstitious feeling at such a time. The bell, by the striking of which we regulate the time, was suspended in the fore-part of the ship, and near it, amongst other places, my presence was frequently required. On my approach each time, my ear was assailed with the most melancholy forebodings, from the excessive rolling of the ship causing the bell to toll exactly as if it were for a funeral; my mind misgave me, I fancied that I heard my funeral knell.

On the morning after the gale had subsided, Capt. Manderson held a consultation with the officers, and likewise with Mr. Plowden, the President of the Select Committee in China; the Hon. Mr. Gardner, of the Bengal Civil Service, and Mr. Anderson of the Penang Civil Service, (Passengers,) when, after maturely considering the state of the ship, her hull being visibly much strained and damaged, and likewise still making a great quantity of water, added to which having only the foremast and stump of the mizen-mast left standing, it was the general opinion that she would not be able to stand another hurricane, and consequently that it was running too great a risk to attempt fetching the Isle of France at this season of the year. It was, therefore, deemed necessary for the preservation of the lives of those on board, to endeavour to gain the nearest port in India, and that the guns should be thrown overboard, as well as part of the cargo from the orlop deck, as soon as the weather would permit. In furtherance of these measures, we shaped a course for Madras, which we reached in five

weeks afterwards, having in the mean time suffered serious privations from the scarcity of water, a greater part of which had been started in the hurricane, in order to lighten the ship, as also great anxiety from the state of the ship, well knowing that it was impossible that she could survive another gale. From the scarcity of materials we had great difficulty in providing temporary expedients for carrying sail; we, however, by degrees, succeeded extremely well, and the Captain of a French ship, which we spoke two days before our arrival at Madras, expressed himself much surprised and delighted at the appearance which we, in this respect, presented. On reaching Madras, we were immediately supplied with anchors and other necessaries, and shortly proceeded to Bengal, accompanied by a Bengal pilot vessel. Fortunately we found at Madras, a ship on the point of sailing for England, and thus had the means of conveying information to our friends of the situation we were in.

Unhappily we had not spoken a single ship homeward bound from the time of our leaving China, and therefore we well knew the anxiety that would be felt from the length of time that would elapse before any information could be received respecting us. On our arrival at Calcutta, after discharging our cargo, the ship was hauled into the dry dock, and after a survey held on her by order of Government, consisting of professional and scientific men, the Bridgewater was condemned. Never did a ship present more melancholy demonstration of the weather she had experienced; every iron knee in the hold and orlop deck was started from its original situation, and stanchions and beams were in a like state. It was evident that she had received the greatest support from a tea cargo on board, which is extremely buoyant, and likewise added stability to the ship. Her stern frames presented a most singular appearance, being completely separated from the main, and Mr. Seppings, the Hon. Company's Surveyor, gave it as his opinion, that in another hour she would have there parted.

In reading the preceding narrative, how manifest is the finger of Providence! for had but a port been burst open, or a gun got adrift, utter destruction must have been our inevitable fate; instead of which not a single man lost his life, and we were enabled to bring the ship into a port of safety. We may, indeed, well say that God was better to us than our fears. After the survey, the following letter was addressed by Commodore Sir John Hayes, as President, to the Secretary to the Board of Trade in Calcutta.

SERVICE.

“ Calcutta, May 31st, 1830.

“ Sir,—With reference to the Board's commands contained in your letter of the 24th instant, I have now the honour to submit the proceedings of the Committee of Survey held upon the Hon. Company's Ship Bridgewater, for the final determination of the Board and his Lordship in Council. In forwarding the proceedings alluded to, I deem it my duty to recommend to the especial consideration of the Board and of Government, the present unfortunate situation of Capt. Manderson, the officers and crew of the H. C. S. Bridgewater, who have suffered so much by their exertions, zeal, perseverance, and endurance, under circumstances without parallel, during her last most disastrous voyage.

“ First. In saving the ship and cargo after being stranded and dismasted at the entrance of Canton River.

“Secondly. In remasting, refitting, and lading the ship under unprecedented difficulty and disadvantages; and lastly in conducting the Bridgewater safe into port, after encountering a hurricane of unequalled violence eastward of the French Islands, which arduous service could only have been effected (under the Deity) by the skill, ability, and unconquerable courage of British officers and crew. In conclusion, I should hope that under a liberal view of all the sufferings of the parties in question, his Lordship in Council will be pleased to direct the whole to be sent to England as passengers at the expense of the Hon. Company, as they are eminently entitled to their highest consideration.

I have the honor to be, Sir,
Your faithful servant,
(Signed) JOHN HAYES.

For C. Lindsay, Esq. Secretary to the Board of Trade.

MARSHAL BERESFORD—BATTLE OF SALAMANCA.

IN that brilliant scene of the great Peninsular drama enacted on the hills of the Arrepiles, now nineteen years ago, I performed the humble part of Assistant-Surgeon in the — Regiment of Foot. Like all military men, I was anxious for promotion, and had been long trying, through every interest I could move, to obtain a staff-surgeoncy in the Portuguese army,—an appointment then open to officers of my rank. My exertions, however, had proved fruitless, and I had almost given up the pursuit.

It was near sunset; the opposing armies were in fierce collision, and as detached masses from either side rushed forward to occupy the various vantage-grounds of the position, the two lines seemed to mingle, yet for a moment, to repel each other, like meeting torrents. A long and twisted stream of grey curling smoke marked the indentations of the combat, whilst the sharp continuous tearing of the musketry, and the deep interrupted roar of the cannon, formed an awful concert.

The Surgeon of my regiment and myself had held a little council-of-war in the rear of our division, then moving into the fight, and it was settled by mutual consent, that he should remain where he then was, with the main body and reserve of our Æsculapian stores, to receive the more serious cases from the front, whilst I was to keep close in with the regiment, to afford the “*premiers secours*” to our wounded comrades before they passed to the rear. I happened to be tolerably well mounted. *En croupe*, I carried a pair of capacious “*Alforjes*,” or Spanish saddle-bags, containing, on one side, a plentiful supply of the minor apparatus of surgery, and on the other, such “*provent*” as Capt. Dougald Dalgetty would have laid in for a like occasion. Suspended to my saddle-bow was a “*borachio*,” or leathern-bag, of country wine. Thus accoutred, I rode on with my regiment.

We had just turned a rising ground, and had come into near view of the lesser Arrepiles, which was still crowned by a strong body of French infantry. A Portuguese brigade was in the act of storming the hill as we came up, and were gallantly mounting its side; but that most commanding point of the adverse position was quite as gallantly defended by the enemy, who as yet maintained their ground on

its crest. A division of the Portuguese army, led on by Sir William Carr Beresford in person, was closely engaged at its base, nobly rivaling the feats in arms of their British Allies.

As we pressed on towards this interesting scene, a mounted officer, in Portuguese staff uniform, galloped towards us from the front, shouting at the top of his voice, "A surgeon, a surgeon—a British surgeon!" In an instant I was at his side, and recognised him to be Colonel Warre, one of the Marshal's Aides-de-Camp. "Follow me," were the only words pronounced by him, as he wheeled round his charger, and again spurred him towards the line of fire.

After a few minutes' gallop we drew up at a covered waggon, to which the Colonel pointed with eagerness as he dismounted. I had already drawn the curtains of the vehicle aside, and perceived that it contained two persons: one in the uniform of a serjeant, the other I immediately recognised as the Marshal himself. He was lying on his back, dressed in a blue frock-coat and white waistcoat. Just below the left breast was a star of blood, bright and defined as a star of knight-hood. It was about the size of that chivalrous decoration, and occupied the exact spot where it is usually fixed. There was a small rent in its centre, black and round. The eyes were half-closed; the countenance in perfect repose, perhaps a little paler than when I had last seen it.

The situation of the wound just over the very fountain of life; the stillness of the wounded General; the appearance of his companion, whose lower limbs were literally mashed; the Commander-in-Chief and the non-commissioned officer laid side by side, silent, motionless, and bloody;—all struck me at the moment as a prelude to the equality of the grave. I asked no questions, for I had come to the conclusion that there might be no tongue to move in answer. In an instant the Marshal's dress was torn open, and my fore-finger, that best of probes, was deep in his side. Not a muscle moved, not a sound was uttered; I felt the rib smooth and resisting below, whilst the track of the bullet led downwards and backwards, round the convexity of his ample chest. I now spoke for the first time since I had entered the waggon, and said, "General, your wound is not mortal." This observation of mine, which I made quite sure could not fail to be particularly interesting to my patient, seemed to have been heard with perfect indifference; for without taking the slightest notice of the very agreeable intelligence I had just communicated, he looked up and asked, "How does the day go?" "Well," said I, "the enemy has begun to give way." "Hah!" rejoined the Marshal, "it has been a bloody day."

During this brief conversation, I had traced the course of the ball by a reddish wheal, which marked its *trajet*, and I felt the missile itself deeply lodged in the flesh of the left loin. The preliminaries for cutting out were arranged in a moment, and the Marshal had turned on his right side, when the wounded Serjeant, having by this time, as I suppose, discovered my trade, began most lustily to call upon "*Nossa Senhora*" and the Doctor in the same breath. I requested of him, in his own language, to be silent; telling him, at the same time, that his General was lying wounded by his side. Upon this the Marshal turned round his head, and with a reproving look, said to me, "Sir, if that poor fellow's wounds require dressing more than mine, dress him first." Both the words and the manner in which they were spoken,

made a strong impression on me at the time, and impressions stamped on the field of battle are not easily erased. I assured his Excellency that nothing but amputation could be of any service to the Serjeant, and that I had not the necessary instruments by me for such an operation.

All parties were again silent, and I proceeded to cut out the bullet. My knife was already buried in the flesh, its point grating against the lead, when the Marshal feeling that I had ceased to cut, and calculating, perhaps, that my steadiness as an operator might be influenced by the rank of my patient, again turned round, and with as much *sang-froid* as if he had been merely a spectator, said in an encouraging tone, "Cut boldly, Doctor; I never fainted in my life;" almost at the same instant I placed the bullet in his hand.

When the wounds had been bound up, the patient demanded what steps he should next adopt. To this I replied that it would be prudent to have himself bled after some hours. "But who is to bleed me?" quickly rejoined the Marshal. I was in some measure prepared for this question, and had already determined on the course I should follow.

From the moment I had recognised the Commander-in-Chief of the Portuguese army lying wounded in a waggon, close in with the enemy, and had ascertained that his wound was not necessarily mortal, I saw that my being on the spot, at such a moment, might lead to my promotion. A fair, unimpeachable opportunity of tendering fresh services to him on whom the accomplishment of my ambition seemed to depend, was now afforded me. But such is the influence of an unflinching, unaffected firmness of character in a chief over those below him, and such the impression left on my mind by what I had just witnessed, that I felt convinced I should establish a higher place in the Marshal's good opinion by remaining in the fight, than by volunteering to leave it, even for the purpose of attending to his own wound. I, therefore, respectfully submitted to his Excellency, that my regiment was then probably in action; that I should be sorry to be out of the way, when my friends and comrades might need my assistance, and that I hoped he would be kind enough to permit me to join them. "Most certainly," was the reply.

I saw no more of the Marshal for many weeks, and when I had the honour of being again presented, I found him very ill, suffering much from inflammation in his side, and a profuse discharge from his wounds, kept up, as was afterwards discovered, by some portions of woollen cloth, which the bullet had carried forward from the breast of his coat, through the loose folds of which the missile had passed before it entered the flesh.

In quitting the Marshal on the field, under the circumstances and with the impressions I have just described, I followed the course most consonant to my feelings, my sense of duty, and even my views of my own interest at the time. Whether I judged rightly upon the latter point or not, certain it is that when I appeared in the next great battle-scene at Vittoria, the following year, I had already, for some months, filled the station of Staff-Surgeon in the Portuguese army.

D. B.

London, 2nd April, 1831.

ON CONDEMNING SMUGGLERS TO SERVE IN THE FLEET.

TO THE RIGHT HONOURABLE THE COMMISSIONERS FOR EXECUTING THE
OFFICE OF LORD HIGH ADMIRAL.

My Lords,—The interest which your Lordships have taken in every thing which relates to the welfare and concerns of the British Navy, and which has been so recently evinced after your accession to office, induces an old officer to hope you will not think him presumptuous in bringing before your Lordships' notice, a subject which has been long felt by the whole service, not only as the greatest degradation, but also as being most injurious both to its discipline and welfare. I allude to the practice of sending smugglers, sentenced to banishment for a violation of the laws of their country, to serve on board His Majesty's ships of war in commission.

The stigma which must consequently be attached to such a custom, does in fact place the British seaman on a level with felons—and has long been felt, though silently, yet not the less acutely, and the seamen naturally ask what they have done to merit so severe and cruel a reflection.

It is impossible that the Lords of the Treasury can be aware of the serious blow it is to His Majesty's naval service, and what the feelings of the captains and officers are at seeing their ships so degenerated as to be converted into gaols. The sailors feel it, if possible, more severely than even the officers, from being obliged to mess and associate with men who have been convicted as felons.—It damps the pride and ardour both of officers and men. Common sense and experience point out, that men so sent on board must be expected to take advantage of any opportunity that may occur to sow the seeds of discontent and sedition. This dangerous custom was first resorted to during war, when England had a very large navy in commission, and when seamen had become so scarce that it was difficult to man the fleets, and they were glad to get any description of persons. Such times plead an excuse for sending on board ships of war any men who had been bred to the sea; besides which, in war, smugglers were not so numerous, and your fleets being very considerably larger than on peace establishments, it was not of so much consequence. But now, when British seamen are so abundant, that they are starving in the streets for want of employment, it is unjust and cruel to deprive them of their bread, by forcibly putting into their situations men whom the law regards as convicts, and thereby, instead of relieving the seamen, adding to their miseries and distresses, and that at a time when seamen should receive every encouragement to enter into your ships of war, instead of those of foreigners;—besides, reconciling men to your ships of war in peace, might, in a great measure, if not wholly, do away with the necessity of pressing in time of war, and at all events greatly reduce or assist in abolishing by degrees the necessity for corporal punishments; but this can never be expected to take place so long as discontented and desperate characters are sent on board, and that against their will, to serve as part of the ship's company. In short, both Reason and Justice are against the continuance of such an unjust practice; and if the wel-

fare of the British Navy is of any consideration, there cannot be one reason brought forward in support of this custom. A very heavy and disagreeable responsibility attaches to the officers from having charge of a set of smugglers whenever a ship arrives in port, where the companies of all ships of war, both English and Foreign, go on shore on leave. The orders received with the smugglers are such, that to prevent their escaping, they are put in irons every night, which gives the impresson to our countrymen and foreigners, that the greatest tyranny and oppression exist on board British ships of war, and gives seamen such a dread of our naval service.

In the army, military delinquents, that they may not disgrace any regiment, are formed into a separate corps for the coast of Africa; but in the navy, civil delinquents are forced upon them, as if the welfare, credit, and *purity*, of the British Navy were not of equal importance to that of the army. Happily the day is gone by, and it is to be hoped for ever, when the Board of Admiralty was so degenerated as to be formed by what was called a nursery for young statesmen.

The Navy hailed with joy and satisfaction the appointment of His Most Gracious Majesty, as Lord High Admiral; and the Navy, always neglected till then, *now* see with the greatest delight four naval Lords and one naval Secretary appointed to that Board, and the eyes of both seamen and landsmen are watching what will be the first steps of a Board composed of five professional men towards bettering the condition of the service, and putting it on a footing suitable to the dignity of this great country. If your power to do good and benefit the country is equal to your kind intentions, we shall not be disappointed. Your Lordships are capable of judging of the hardships and degradation of the grievances here complained of. If the authority of the Admiralty is so circumscribed as not to be able to prevent British men-of-war from being made a receptacle for convicts, and that in a time of profound peace, as every part of England is now about to benefit by obtaining a reform—if an appeal is made to the highest powers in behalf of the grievances of the seamen, it is impossible that they would refuse to extend the same indulgence to the British Navy which is going to be extended to every individual on shore; and the great interest which the liberal and high-minded nobleman at the head of the present Administration has ever taken in our Naval service, makes me feel confident that we should have his Lordship's support.

In making this appeal, it is only with the sense of public duty to the service to which I have the honour to belong, and trust, for the honour of that service and for the good of the country, and for the sake of British seamen on whose behalf it is made, that it will not be made in vain.

I am, my Lords,
Your Lordships most obedient and faithful servant,
JOHN PHILLIMORE.

The Ray, Maidenhead,
15th March, 1831.

THE BRITISH CAVALRY ON THE PENINSULA.*

BY AN OFFICER OF DRAGOONS.

THE short campaign terminating with the battle of Corunna, forms an epoch in the Peninsular war. It was called disastrous, and perhaps such is not altogether an undue epithet; the blame was naturally laid to the charge of the gallant chief; considering, however, the circumstances of the case, we cannot accuse the Government of speaking very strongly on the subject. The officers of the crown naturally wished to shift the opprobrium from their own shoulders, where we candidly think it ought to rest; but with this opinion we have no wish to accuse those ministers of high crimes; they were mistaken as to the state of Spain; they mistook popular feeling for physical power and warlike capability; they were not happy in their choice of political agents; from some of their military emissaries they received valuable information which they disregarded; and this was to be expected, for having fixed upon Spain as a good field on which to oppose the overwhelming power of the French, in which they probably judged correctly, and having determined to seize on the opportunity offered by the patriotic insurrection, they overrated the power of the patriots, and sought only the advice which a man wishes who has made up his mind—confirmation. The disasters of Galicia have been greatly overrated; the retreat was rapid, and the army, in some measure, disorganized; but not more than might have been fairly expected with so young an army; perhaps not more than occurred in the retreat from Burgos, when our army had become accustomed to war. But taking a fair view of the subject, what was the loss? what the sum and substance of the disaster? The enemy could boast of no military trophy; neither British gun nor standard fell into their hands; no officer of distinction was taken. It is unnecessary to except Major Napier, who was left for dead on the field of battle.

In the *petite guerre*, we were eminently successful; the chosen squadrons of the enemy had gallantly attacked and had been bravely repulsed, while in the numerous affairs of posts, the French could not boast of one favourable issue. During the course of retreat from Astorga to Lugo, when the rear was most closely pressed, the enemy never gained even the most trifling advantage, and when the campaign was closed by the battle of Corunna, the British army, suffering from sickness and exhaustion, in great want of shoes and many other necessaries, victoriously repelled the attack of an army superior in every arm, especially in that of artillery, the French having delayed the attack till the arrival of a numerous battery, which did great execution, and among its effects, was the immediate cause of the heavy loss we sustained in the gallant Moore.

The fear of fatiguing the reader prevented us from commencing this sketch of cavalry actions by an inquiry into the comparative *matériel* of the British and French cavalry. He must, however, submit to the infliction, and may, perhaps, find a mere statement of facts with which he is well acquainted. We also find a difficulty in speaking of the

* Continued from page 310, Part I. for 1831.

French cavalry: we know something about them, and perhaps overrate our knowledge; but we feel assured that the majority of British officers who give opinions on this subject are not well informed. Some retain the good old English mode of despising all foreigners: we remember our own boyish opinion, that one Briton could beat two Frenchmen at any time, and more on an emergency. Most boys have a confused idea of little finical men, with powdered heads and pigtails, when they think of French soldiers. We recollect, while at Marlow, speaking in derision to a Frenchman who had served—his only answer was “wait till you meet Frenchmen.” His words were soon recalled to our recollection on the field of Vimeira, when the French at least made an attack worthy of men who meant to do or die. We have descended from our high ground; but although we cannot enjoy this paradise of fools, we heartily disagree with those worthies who see un-mixed excellence in the French horseman. The French cavalry has proved itself a most efficient body. It has been more left to the guidance of its own officers than is the case in our service; and in the field of battle, detachments of cavalry have been more scattered throughout the different parts of the position than has been usual with us.

The French cavalry enjoys the favourable opinion of their army, among whom the chassensrs and hnsards are preferred to the dragoons; from our own experience we should be induced to dispute the justice of this preference. The dragoons appeared to perform all the duties usually allotted to horse soldiers, and to share equally with the light cavalry, the duties of the outposts. There is perhaps a greater difference between the heavy and light dragoons in the French than in our service. The dragoon horses are stronger and taller, and this was systematically arranged at the cavalry dépôts, and not left, as in our service, to the caprice of the Colonel. At one time the light dragoons were most esteemed in our own service; military opinion has changed, and it is pretty generally believed that the success of charges depends principally on the weight of the horses: it may be so, although we have never witnessed any charge in which the weight seemed to have much to do with the matter, nor do we think it has, *always supposing that the dragoon has a sufficient horse under him*, and feels confident that his steed can *carry him well into the fray and safely out of it, in case of repulse*. It is also thought by some that the heavy dragoon is not fitted for the outpost duty; this opinion is quite unfounded: for a long time the Royal dragoons were brigaded with a light regiment, and shared equally with it in all outpost duties, and in doing so with their black horses, acquired the name of “Whitbread’s Hussars.” The equipment of the French cavalry is in many respects preferable to that of our own. The Frenchman’s horse-gear, though very homely, is equally useful with ours, and much more easily kept in order. In dress there is no marked superiority on either side; the English dress is far more splendid and costly; in point of use and comfort they are pretty much on a level. In point of armament the French establishment is greatly superior to ours. To compare the several weapons:—

Carbine.—Our heavy dragoon carbine is pretty efficient; the French heavy dragoon carbine is too long. The chasseur carbine is excellent, it is light, and will carry a ball at least twice as far as is necessary;

our light dragoon carbine is so decidedly bad in all respects, that we have only patience to say, the sooner it is got rid of the better.

Pistol.—A pistol is usually considered as a necessary part of a horse soldier's armament: we have not been informed why an old German writer (perhaps Lloyd) says, "never fire a pistol till you feel your antagonist's ribs with the muzzle." Why then not use the sword? Marshal Saxe, in his reveries, of which we have only a translation, says, "Pistols are to be totally laid aside, they are only a superfluous addition of weight and incumbrance." We never saw a pistol made use of except to shoot a glandered horse.

Sword.—The main dependance of a horseman is the sabre; as to its construction, we prefer giving Marshal Saxe's opinion, with which our experience perfectly agrees. "The sword should be three square, (*i. e.* bayonet-shaped,) and *carefully blunted* on the edges, that the soldier may be effectually prevented cutting with it in action, which method of using the sword never does execution. It should be four feet in length."

The French dragoon has a long straight sword, the handle is heavy and the blade light, by which adjustment the point is naturally raised without effort, while it feels light and manageable in the hand. The chasseur sabre, although not quite so long, and slightly curved, is, in point of fact, much the same as the heavy dragoon sword, as it is equally applicable to the thrust and is equally handy. The sword of the British heavy dragoon is a lumbering, clumsy, ill-contrived machine. It is too heavy, too short, too broad, too much like the sort of weapon with which we have seen Grimaldi cut off the heads of a line of urchins on the stage. The old light dragoon sabre (for we hear that they have got a new one) is constructed in utter defiance of Marshal Saxe and his reveries, and as nearly as possible the reverse of what he suggests. We can answer for its utility in making billets for the fire. We recollect congratulating a dragoon who at a *rencontre*, in our absence, had sacrificed a French officer: "Yes, said my friend," who, hy-the-by, was a most gallant fellow, "I had not room to cut, so I ran him through." What would the Marshal have said to the education which had prompted such an apology. There can be no doubt that thrusting is the proper use to make of the sword; it is a brutal operation; that is not our business; let those who make war look to this and much more. We only wish to see our cavalry efficient when they are employed, and we can see no reason why a heavy dragoon should have a straight sword and a light dragoon a curved one.

The Lance.—Of this queen of weapons we know little; in single combat it is undoubtedly most formidable, and in squadrons, perhaps, it is most useful in the hands of a cuirassier. All the European powers concur in having cuirassiers, dragoons, light dragoons, hussars, and lancers; *grenadiers à cheval* may perhaps be added; but in all armies there is virtually but two classes, cuirassiers and dragoons, the former alone being never employed on the outposts.

We wish that the advantage of defensive armour was more fairly considered, as we feel convinced that its utility is underrated in our service. Instead of a tedious quotation, we beg to refer the reader to General Rogniat's work "*Considerations sur la Guerre.*"

The French cavalry appeared to move more compactly than ours,

and such is probably the case. The superior breeding of the English horses renders them more unsteady than the half cart-horse of the Frenchman. Let any one observe the steady charge of a squadron of yeomanry; one half of the horses were but a few days before in the plough, yet they keep their line, and halt in as good order as a squadron of dragoons, whose horses have been trained to this work alone.

The account was closed at Corunna. The war was commenced *de novo* by augmenting the small force at Lisbon, which army was placed under the command of Sir A. Wellesley, who landed at Lisbon in April 1809. That officer had been wisely chosen, on account of the talent he had shown in the short campaign of the preceding year. Pity that the same principle of selection had not been adopted with regard to Lord Paget. The cavalry of Sir Arthur's army appears to have amounted to about fifteen hundred swords, under command of Lieut.-Gen. Payne. The whole force was put in motion on Sir Arthur's arrival, and moved towards the north, to dislodge Soult, whose headquarters were at Oporto, where he was surrounded by most part of his army. The French cavalry was greatly superior to ours in point of numbers, and the light horse, under the distinguished Franceschi, was actively employed against the Portuguese insurgents, or patriots. On the 4th of May, a post of the French was attacked, and 4000 men dislodged from a strong position at Grijon; on the retreat of the enemy, two British squadrons charged and secured many prisoners. On the following day, the brilliant passage of the Douro was effected. Without entering into the detail of this most interesting operation, we shall merely notice that part of it which afforded an opportunity of employing cavalry.

Brig.-Gen. Murray was ordered to cross the river five miles above Oporto, at Barca d'Avintas, with a view to intercept the retreat of the French along the right bank, and also to prevent their crossing over to the province of Beira. This force came too late for the first of these objects, as the enemy had for the most part passed on, and when it came did nothing. We beg to cite the following passage from Colonel Napier's admirable work:

"Major-Gen. Charles Stewart, and Major Hervey, 14th Light Dragoons, impatient of this inactivity, charged with two squadrons, rode over the enemy's rear-guard, as it was pushing through a narrow road, to gain an open space beyond; Laborde was unhorsed, and Foy badly wounded. On the English side, Major Hervey lost an arm, and his gallant horsemen receiving no support from Gen. Murray were obliged to fight their way back with loss."

It is difficult to imagine any thing more satisfactory than this little attack. The small force of cavalry, unsupported, was unable to hold the ground it had gained, far less could it secure prisoners, which is always a difficult task for cavalry. It is not proposed to give any continuous account of the war, this is not our object—it is also unnecessary, it has been done, and is doing over and over again; to those who wish valuable information on the subject of the Peninsular war, as well as military instruction, Colonel Napier's book is complete. At the battle of Talavera, we have to record the very gallant conduct of the British cavalry, at least of one regiment, and we do this with great pleasure, as we consider the services of that regiment to have

been greatly underrated; while it is some pledge of our candour that we believe we are unknown, even by name, to any officer who served with the 23rd Light Dragoons at the battle of Talavera. The French cavalry force on that occasion amounted to seven thousand swords, under the command of a highly distinguished officer, Latour Maubourg.

A division of dragoons under Milhaud, was employed to keep the Spaniards in check, another division was in reserve, the remainder was divided among the different columns formed for the attack on the British position.

A valley, which in accounts of the battle is usually called "the Great Valley," passed in front of the left and centre of the British line. On the 28th of July, two divisions of French infantry were marched up this valley, threatening the left of the position so much as to induce Sir Arthur to send an order for the cavalry to charge: the order was transmitted to Gen. Anson, commanding a brigade composed of the 23rd Light Dragoons, and 1st German Hussars.

The ground was very unfavourable for cavalry movements; and had the Colonel of the 23rd been consulted as to the expediency of the measure, he would probably have explained the obstacles which were most manifest. Colonel Seymour received a simple order, and he at once obeyed it, leading his regiment to almost certain destruction, over ground nearly impassable to a single horseman; many fell in the descent into the valley, Colonel Seymour among the number. The remainder were rapidly formed by Major Ponsonby, and gallantly charged the French infantry, who threw themselves into squares to resist the 23rd. The original attack of the French, which had occasioned the greatest alarm, was paralyzed, and the attempt was not renewed, even after the destruction of the 23rd, which proceeded to charge a regiment of chasseurs, upset them, and was only repulsed by a brigade of fresh dragoons sent to the relief of their comrades, and who charged and nearly destroyed this gallant regiment. We shall now quote from three very high authorities: first, from "Victoires et Conquêtes" (resumés), which after giving an account of the repulse of the division La Jusse, continues:

"Les divisions Villatte et Rufin reçurent ordres de se diriger la première dans le vallon, et la seconde par la chaîne de montagnes de la Castille, et de chercher à faire une trouée. Ces divisions étoient suivies par la cavalerie, qui devait saisir le moment favorable pour déboucher dans la plaine sur les derrières de l'ennemi."

"Deux régimens de cavalerie Anglaise chargèrent alors les Français, passent sous le feu de l'infanterie entre les divisions Villatte et Rufin, et vont attaquer le 10me et 26me Chasseurs-à-cheval. Le 10me régiment, trop faible pour soutenir le chocq, ouvrit ses rangs et laissa passer la cavalerie ennemie, mais se réformant sur-le-champ, il coupa la retraite aux Anglais, et prit ou tua presque en totalité le 23me de Dragons, qui étoit à leur tête."

The Frenchman fairly avows, that the French brigade was too weak to withstand the charge of the two British regiments, as he styles the *débris* of the 23rd. We shall next quote Colonel Napier:

"Villatte's divisions, supported by two regiments of cavalry, was seen advancing up the great valley against the left, and beyond Villatte, Rufin's

division was discovered marching towards the mountain. Sir A. Wellesley ordered Anson's brigade to charge the head of the column.

"This brigade coming on at a canter, and increasing its speed as it advanced, rode headlong against the enemy, but in a few moments came upon the brink of a hollow cleft, which was not perceptible at a distance; the French throwing themselves into squares, opened their fire, and Colonel Arechild commanding the Hussars, whom forty years' experience had made master of his art, promptly reined up, exclaiming, 'I will not kill my young men!' The English blood was hotter. The 23rd rode wildly down the hollow,—men and horses fell over each other in dreadful confusion; the survivors mounted the opposite bank by twos and threes. Colonel Seymour was wounded; but Major Ponsonby, a hardy soldier, rallying all who came up, passed through Rufin's and Villatte's division, and reckless of the musketry from each side, fell with inexpressible violence on the chasseurs in the rear; the combat was fierce but short. Victor had perceived the first advance of the English, and detached his Polish lancers and Westphalian light horse to the support of Villatte; these fresh troops coming up, when the 23rd was already overmatched, entirely broke them, and they retired leaving nearly half their numbers."

We have next to refer to Colonel Jones, whose book, though only an outline of the war, is highly esteemed for its accuracy and clearness; after mentioning the charge of the 23rd, Colonel Jones adds,

"The regiment was almost entirely destroyed, notwithstanding which, the enemy was so astonished at the boldness of the attempt, that the columns halted, and the division of Spaniards under Bassecourt, detached for that purpose, holding the light troops in check—*this imposing movement, which threatened the destruction of the army, produced no result whatever.*"

Such is the cursory view of this gallant charge as it is given by three very high authorities. Colonel Jones alone has given an opinion pretty generally held in the army, viz. that this charge not only checked Villatte's movement, which of itself was a service of vital importance, by giving Sir Arthur time to manœuvre his forces; but farther, as far as could be judged, prevented a renewal of the attack in that quarter, which was not repeated. We think Colonel Napier has given short measure of praise to the 23rd; indeed, justice demanded a more laudatory detail of the case. He again alludes to it in his "Observations."

"The whole of Villatte's and half of Rufin's divisions were paralyzed by the charge of a single regiment."

We are convinced that the writer of the "History of the Peninsular War" wishes to deal fairly with all, and faithfully to record the events of the war; while writing the above we were informed that this part of his work had been already attacked, and we sympathize with the gallant Colonel on the many attacks he will receive from wounded pride during the progress of his labours, and which may be some small offset against the satisfaction which he will experience in the enjoyment of his well-earned fame. We have read accounts of this charge by several authors, in most of which exceptions are taken against the 23rd; one we remember is, that the cavalry had not reconnoitred their front, another, that they had no reserve; but these and many other objections are very idle specimens of the easy art of finding fault. It is not the province of an officer of cavalry in position to reconnoitre his front; at least, it is the *especial* duty of the staff or engineer officer who

takes up the ground, to point out any peculiar features in the probable line of action; and this is evident, when we consider that a corps, and especially one of cavalry, is frequently moved up and ordered to take part in a battle, when no time can be allowed for reconnoissance, and where the best hopes of success would be lost by a moment's delay. Had the Greys reconnoitred the ground when they made that gallant and decisive charge against D'Erlon's corps at Waterloo? It is well known that they were ignorant as to what they were charging, yet Ponsonby's brigade by their charge also contributed greatly to the security of the position. The position at Talavera was, at least, equally threatened by two French corps, yet the charge which paralyzed the attack has been judged ill-advised and rash. The 23rd had no share in the motives which led to the order to charge, they received the order and obeyed it; Seymour and Ponsonby did their duty, and did it well; these officers had no desire to "kill their young men," but relying on the Commander-in-Chief as to the expediency of his orders, they allowed no obstacles to impede them. We truly think that the 23rd may challenge the world to produce an instance of greater effect produced on a well-disciplined enemy by so small a body of men.

The only parallel which occurs to us is the charge of the Polish Lancers at Somosierra, which Napoleon probably ordered under a chivalrous excitement, risking most unfairly the brave lancers, who would have been destroyed had a single Spanish regiment kept their ground; and this dangerous measure was adopted most gratuitously, when there were large corps of infantry at hand. We hear nothing in the French accounts of ill-advised attacks. The Emperor did not consider such language likely to edify the chivalry of his dragoons; he covered them with glory. We pursued another course, and the above and another instance of unjust censure had a very bad effect on the spirit of the British cavalry. We do not believe that Napoleon would have thanked Arenchild for the fruits of his forty years' experience; that officer probably did what he considered his duty, and he had *many* other opportunities of evincing his valour and skill. We would be among the last to derogate from the merit of that gallant veteran; but on this occasion, we must give undivided praise to Ponsonby and his people, who gave a different interpretation to the order. We have little hope of reclaiming any slanderer of the British cavalry, who, it appears, are generally accused of charging too much or too little.* In the arrangements of the army, it unfortunately happened that the 23rd was soon afterwards sent home.

* The French cavalry, although so vastly superior in number, appear to have taken no active share in the battle.

YACHT CLUBS AND REGATTAS.

THE History of Naval Architecture has not, since the commencement of our commercial greatness, manifested so many decisive proofs of masterly research as it has within the last half-century. It has been allowed to occupy that distinguished place which it has so long and justly deserved, as a science of the utmost possible importance to a maritime people,—while its principles have been studied and professed by men well known in the naval circles for their scientific acquirements and their recondite learning. Within this limited period, not only have the most valuable improvements been effected in the construction, speed, and general equipment of our naval force, but men, who from early life have been attaining, in actual service, a practical knowledge of their profession, have been encouraged to communicate to their country the result of their experience. The situation of England, the unparalleled glory of her victories, the success and the extent of her commerce, all tend to prove that the pride and the honour, the welfare and the prosperity of the nation, depend materially on the practical efficiency of her navy. We have been led into these remarks on considering the progress and prospects of the Yacht Clubs, and as the time is not far distant when the squadrons of these little navies will be preparing for their annual expeditions, and for the great festivals connected with them, we propose to devote a few pages to a brief inquiry into the actual merits and utility of these institutions. There are, we believe, few seamen of judgment and experience who have not admired the beautiful vessels of the "Experimental Squadron," and no one, we imagine, will say that those built subsequently on the plans of different officers, as well as those now constructing in the public yards under their superintendence, do not at the same time confer honour on the service to which they belong, and hold out a cheering prospect of future and incalculable benefit. We sincerely trust, that the different naval administrations will readily encourage every such development of talent,—that they will afford our heroes every possible opportunity of ascertaining in the dock-yards the comparative value and utility of any improvement that may suggest itself to their observation, and that they will promote the ends of science by honouring these manifestations of research with their immediate support and patronage.

But while this laudable spirit of amendment has been sensibly spreading in the public service, the zealous superintendents of the private yards have evidently kept pace with the progress of improvements. To effect this object, the Yacht Clubs have afforded them abundant opportunities of acquiring knowledge, and of applying the results of their practice to the advancement of a great public cause; for the improvement of naval architecture is unquestionably a public cause of the utmost magnitude, and we know no measure so calculated to promote the enlightened views of the scientific members of our navy as the establishment of Yacht Clubs. On these grounds, especially, do we advocate their general encouragement. There are, we are convinced, few seamen who are not familiar with the splendid models of many vessels of the Royal Yacht Club, and every succeeding year brings us fresh proofs of some important advantage gained either in

construction or in speed. The Royal Yacht Club is supported by noblemen and gentlemen of the first rank and opulence, and consequently no expense is spared in the equipment of their vessels. The pride of the club, this year, may probably be beaten next season by a new competitor, built purposely to oppose her; and what one gains at one period by superior speed, is done away at the succeeding contest, by another more decisive and important improvement. Hence, it must be evident that a continual emulation is excited among all classes, from the opulent proprietor to the practical artisan,—and the beneficial results of this praiseworthy rivalry are far too obvious to require any comment. That these advantages were fully foreseen by the promoters of Yacht Clubs, there can be little doubt; they could not have been ignorant that, in establishing on a permanent and regular scale a society so characteristic of this nation, they were effecting a gradual but marked benefit for the country at large. But this is neither a question of taste nor opinion,—if we appeal to facts which cannot be misunderstood, we see the measure supported by the first naval heroes of the day, by men who are regarded by the public as the brightest ornaments of our annals of maritime achievement. That these men are more qualified than any other body to decide on the advantages of such institutions, is a proposition which it requires no reasoning to demonstrate,—and their names would certainly not be enrolled on the list of the Honorary Members of the Royal Yacht Club of Cowes, if they thought these clubs of no public utility. We have, however, the distinguished authority of one of our most experienced officers, who has served most actively in the fleet of this country; who has shared the perils of those whose home is on the waters; who has given additional lustre to that national banner under which he sailed, and whose name is identified with the British seaman;—we say it with pride—with that pride which the circumstance must always excite in the mind of an Englishman, that the Royal Yacht Club of England is honoured with the exalted patronage of King William the Fourth.

But it must not be considered that the encouragement of naval architecture is the *only* advantage effected by the yacht clubs; money, in consequence of their establishment, is extensively circulated in the commercial world; while trade, more especially that connected with shipbuilding and the equipment of vessels, is excited and supported. In a time of war also, the advantage of commanding the services of a well-disciplined and orderly body of seamen, such as is employed in the clubs, must be allowed to be incalculable by all who understand the machinery of naval governments. We have, therefore, seen that the merits of Yacht Clubs are great and important, and that they are entitled to the cordial and consistent support of the British people.

We have now to discuss the utility of Regattas. We are fully aware that on this subject there exists a great diversity of opinion;—the regatta has been decried as an idle amusement, interesting only to those concerned, and it has been asserted that its observance is a waste of time and of money. This certainly appears to us a very narrow view of the question; if regattas were discontinued, it is by no means probable that the proprietors of yachts would reject altogether the establishment of a contest among themselves to determine the comparative

merits of their several vessels, and to excite a degree of emulation among their seamen. Now, we would ask, why should not the public take a part in the festival? why should a commercial people withhold their tribute of support from an amusement so characteristic of the national taste? Who is there who has witnessed a regatta, such as that annually observed at Cowes, at Plymouth, at Belfast, or in the Bay of Dublin, (for we speak only of those conducted on a liberal and extensive scale,)—who is there, we repeat, who has witnessed that impressive scene, and not felt his heart expand, when the conquering hero of the wave returned, greeted with the applauding cheers of the beholders, and welcomed to the shore by music? The competition of a boat-race is precisely what is required to fulfil the intentions of the advocates of yacht clubs, and even if they were recommended by no other circumstance than the emulation and pleasure excited among the seamen of the vessels themselves, we should consider their claim on public notice fully established. Is the sailor who has fought his country's battles to have no season of relaxation from toil? Is the "nursling of the storm" to be denied even this gratification, so congenial to his feelings and so appropriate to his calling? We are not, on the other hand, unmindful that the measure has been condemned as inimical to the interests of morality. We despise such sophistry. Are labour and toil for ever to be the portions of the children of men? Is rational pleasure prohibited by the fundamental laws of moral philosophy? "Away," to use the words of an eloquent moderu writer, "away with this sullen, this morose, this unnatural philosophy, if it deserve the name, which would pluck every flower from the thorny wreath of mortal destiny; which, with presumptuous hand, would tear from creation the resplendent robe with which the Deity Himself has invested her, and cry shame on the very sun as he pursues his course in triumph through the heavens."

In whatever point of view we examine the measure, either as the means of exciting emulation in the yacht clubs, as a national festival, or as the grand holiday of the seamen, we are more and more convinced of its public utility. We call, therefore, on the people, and on our naval heroes, to support these pursuits in every possible way; and we earnestly recommend them to establish regatta clubs in different parts of the kingdom, which will ensure a repetition of the festival, and provide the necessary funds by a less fluctuating method than public subscription, which must cease with the period prescribed and the object specified.* By these means we may venture to affirm that the country will reap much and valuable benefit, and learn to entertain a proper and legitimate value for the interests of that navy, which numbers among its heroes the names of Howe, Rodney, and Nelson.

O. B.

* A club of this description has been established at Plymouth, chiefly through the indefatigable exertions of Capt. William Brooking Dolling, R.N., R.Y.C., to whom, it is but just to say, the advocates of these pursuits owe a deep obligation, for his assiduous and patriotic zeal in behalf of this important national cause. The club is under the immediate patronage of His Majesty, and is supported not only by the most opulent residents and the naval and military officers in the neighbourhood, but by the noblemen and other influential individuals in different parts of the county.

LANCERS AND LIGHT DRAGOONS.

THE observations on Light Cavalry in the Field, by the officer who signs himself *Vanguard* in the United Service Journal for April, are full of such good sense, and are written in such a candid and liberal spirit, that they have deservedly attracted the attention of all officers of the cavalry who are readers of that well conducted publication. From several of his terms and expressions, however, it may be inferred that Vanguard is an infantry officer, and though he seems extremely conversant with the nature of the duties of cavalry in the field, still he is in error as to some points, on which, to judge from his candour, he will not disdain to be set right. In the first place, he really is quite mistaken in supposing that the fashion of mounting our light cavalry upon very slight horses any longer exists; on the contrary, it has been, and is the earnest endeavour of both the late and present Inspector, as well as of the Lieutenant-Colonels of the light cavalry, to obtain the strongest horses that the Government allowance can procure, which allowance is the very same both in light and heavy cavalry. A good judge of horses would probably pronounce those of the 9th Lancers and 8th Hussars, for instance, to be as strong and serviceable animals as can be wanted for any description of service.

Then, as to the fire-arms of the cavalry, it is very true that hitherto they have not been, until of late years, considered enough as to their quality or weight. The light-dragon carbine was certainly an inefficient weapon, and had also the fault of a bore which admitted of no bullet except those expressly intended for it, a great disadvantage when employed in front of the army. The carbine of the heavy cavalry was again a still more inferior weapon, with a loose ramrod, not secured in any way to the piece, or to any part of the man's accoutrements, so that, at common field days, nothing was more common than for the soldiers to drop and lose their ramrods altogether. There was also the appendage of a bayonet to the heavy-dragon carbine, than which a more useless accompaniment to a weapon already very weighty and awkward, could hardly have been imagined. As heavy cavalry, if strictly considered as such, are less liable to be employed at the outposts than the light, one does not see either for what possible reason they were to have a heavier carbine than the others, because it is natural to infer that the carbine which carries sufficiently far to be formidable at the outposts, must be equally fit for the very few occasions where cavalry could be liable to use it elsewhere. All these points, however, were brought under the consideration of the authorities more than a year ago. Several pattern carbines were made by the best gunsmiths; a great many experienced officers, and even old private soldiers, (opinions never to be despised,) were consulted upon the details of all that regards the efficiency of the weapon; and a series of very satisfactory trials was made with the utmost exactness and patience, under the direction of the Ordnance Department, who decided upon a carbine which had the merit of carrying full as far as the French one, was much more handy and convenient, and was constructed upon superior principles, as regards the quality and durability of the lock. To have issued a complete supply of these new carbines to the cavalry in time of peace would have been a needless waste of public money; but

Vanguard will no doubt be happy to learn that, whenever wanted, there is this weapon prepared for the use of the cavalry, which must give them a great advantage whenever they shall again appear at the outposts before their Continental rivals. There is but one amendment which some officers would have preferred as regards the new carbine, but which has been rejected, perhaps from some pardonable prejudice for old habits. It is the method used by the French Chasseurs of wearing the ramrod, instead of having it fixed to the carbine by a swivel, stuck through leather loops sewed about twelve inches apart upon the front of the pouch belt. By this arrangement, when the man is not using it, he puts it through the loops and it lies across his breast, with one end elevated in a line with his left shoulder, and the other depressed towards his right hip; in short, following the direction of the pouch belt. A slight leather thong by which it hangs suspended from the pouch belt when skirmishing, effectually prevents the French Chasseur from losing it; he has it always convenient and ready to his hand; and the carbine is of course all the lighter and more simple in construction, from not having the ramrod permanently attached to the barrel with a swivel and iron loops. It is said that even a still greater improvement, if possible, than giving them an excellent carbine, is contemplated by the authorities for the accoutrement of the cavalry, namely, the suppression of that most unnecessary of the dragoon's incumbrances, the holster pistols; so useless are these articles, indeed, that it is ten to one that Vanguard, if he is an infantry officer, scarcely knows of their existence; at all events, he never can have seen them used, except to shoot a lame or glandered horse, for it would be difficult to produce an instance of a cavalry soldier having on any one occasion fired his pistol at an enemy.

There is but one more error in which Vanguard will, no doubt, allow himself to be set right, as regards the existing state of things in the cavalry. He observes, that the British army is incomplete as regards our having neglected to organize a certain number of our regiments as *Chasseurs*; now so far from this being the case, it has been thought of so much importance for our cavalry to be able to act as light infantry, when occasion requires, that in the Book of Instructions and Movement, issued for trial early in 1829, and still in practice with the cavalry, a chapter is entirely set apart for the service of *dismounting to act on foot with carbines*; and among the numerous officers of all ranks who were consulted upon all its details by the able and experienced general officer who compiled and issued that book, there were none who did not concur in the necessity of such a practice being laid down in the most explicit manner. Experience had long since made them well aware of the absurdity of *Druidar's* directions for *dismounting to form battalion*, an operation by which half the officers were changed in their places and in their commands, the horses were fastened together in such a way as would be most dangerous when in the presence of an enemy, and so much time was wasted in a complete new telling off and other ceremonies, that, for any emergency of real service, the attempt would have been absolutely ridiculous. According to the new practice, the centre man of each three holds the bridles of his two neighbours, by which means a squadron of sixty files will furnish forty files to act as light infantry; and being all rights and lefts of threes, the dismount-

ed men require no fresh tellings for moving by files while they remain on foot. Thus, although a larger proportion of light infantry is furnished by each squadron than Vanguard himself contemplates, the horses are left in a perfectly manageable state, and each man who remains mounted, having only a couple of horses to lead in their usual places by threes, no difficulty whatever would occur in marching off the whole of the horses either to the flank or rear, if it should be advisable to alter their position, in order to avoid cannon-shot or other danger during the absence of that proportion of their riders who had dismounted to act as light infantry. Vanguard may then reassure himself as to the strength and size of our light dragoon horses; as to the certainty of an admirable carbine being ready in case of a war; and as to the attention now paid to the practice of dismounting cavalry rapidly and easily, to act in the same way as the French Chasseur,—a practice which he is fully justified in considering of the very utmost importance.

As to that part of his judicious paper in which he speaks more particularly about the disadvantage of Lancer regiments in the British service, many farther arguments may be adduced to show how correct and practical a view he has taken of his subject. The greatest of all military authorities has frequently declared his opinion, that in our service all cavalry should be *cavalry of the line*, that is to say, fitted equally for all purposes of service.

Is not the reason obvious? An English army takes the field with the smallest proportion of cavalry of any European power. How can it then be possible to divide a force scarcely sufficient for the ordinary and necessary duties dependent on the infantry, and requisite for their security and safety, into the various separate departments, if such an expression is applicable, of first, the heavy dragoon or cuirassiers; secondly, the lancer; and thirdly, the light dragoon or hussar? out of these three descriptions of cavalry enumerated, only the latter can in strictness, and supposing us in this respect to adhere to the customs of the other European cavalry, be called proper for out-post duty. Now let us examine our disposable force, in which the regiments in India must not be reckoned of course. We have, including the Life Guards and Blues, thirteen regiments of heavy cavalry, three regiments of lancers, and six regiments of hussars and light dragoons. If our army, when called upon to take the field, is to depend, for its outpost service on the six last-named regiments, supposing them all ready for instant embarkation, it would, as to numbers, be poorly provided, especially when their very weak strength is considered. But the fact is, that the distinction of heavy and light dragoon in the British service is only in dress and equipment, and it is rather a singular anomaly, that the heavy dragoon, from being lighter equipped, and without the sheepskin, is rather of the two better fitted for outpost duty than the light dragoon and hussar. In the late war, the Royals and other heavy cavalry regiments, necessarily took their share of outpost duty along with the other cavalry, and gained well-merited praise for their activity in its performance.

The employment of lancers in the Continental armies is quite a different case from arming British regiments in that manner. The Russians, Prussians, and Austrians, have plenty of light cavalry for all the

purposes of a great army ; they can afford to set apart the cuirassiers for the reserve, and to have their lancers held in readiness to complete the successes over infantry which may have been gained by other troops ; nor are they ever obliged, by want of other descriptions of cavalry, to expose lancers in situations where the carbine would be necessary for their efficiency or protection.

At the termination, however, of the late war, when the French armies were entirely reorganized under the Bourbon dynasty, it was decided by the opinion of a Board, composed of some of the first cavalry officers who had been formed under the master-hand of Napoleon, that it was not desirable to retain the system of lancer regiments ; and they recommended instead, that each regiment of chasseurs should have one of its four squadrons armed and trained as lancers, for which squadron the most suitable men and horses should be selected. This arrangement was accordingly adopted, one complete regiment only of lancers being still retained, and embodied as such in the royal guard.

It was well known among the superior officers of the French cavalry, that Napoleon had the intention of making an arrangement regarding lancers very much of the same sort. He proposed, instead of whole regiments, to have independent lancer squadrons of about sixty files, one attached to each brigade or division of infantry, when on service. These squadrons were to furnish orderlies to the general officers to whose brigades or divisions they were attached ; they were also to take all letter parties and other duties required for the communication of orders, &c. between the stations or positions of the infantry corps ; they were, in short, to undertake all that kind of work in attendance upon the infantry, by which the regular cavalry regiments are so much weakened and harassed on service. The squadron, after furnishing the men necessary for the performance of these duties, was to follow all movements of the infantry division to which it belonged ; it was to be employed in protecting its retreats, in examining the roads by which it might have to advance, and, above all, in following up its successes against an enemy's infantry, upon which, when broken and thrown into disorder by musketry or the bayonet, these lancer squadrons were to be let loose, in order to complete their confusion and defeat.

Independent of the high authority by which this plan was countenanced, it seems very obvious that great advantages must have resulted from its adoption in the French service, and it may admit of a question whether such an arrangement, notwithstanding the smallness of our cavalry force, might not be followed with much benefit by our own armies in the field. How often was the Duke of Wellington obliged to reiterate his orders in the Peninsula for limiting the number of orderlies, by whose absence, in attendance upon the staff of the army, the cavalry regiments had become too much weakened and harassed ; and yet how very necessary it is for the staff to be well attended by mounted men for the circulation of orders, and many other equally important purposes. Suppose these men then to be taken from a small corps permanently attached to each division of infantry, their services would be perfectly available for the staff, and yet they might, at any moment, join their squadrons for an attack.

Of one point there can at all events be little doubt, viz. that the time when the lancer is most formidable, is in the *melee* of broken infantry, whether their disorder has arisen from defeat or from a success

too rashly followed; and both on this ground and because lancers must rely so frequently on the fire-arms of the infantry for their protection, it seems advisable that the lance should never be at any considerable distance from her best friend the musket.

As to the notion that in ordinary charges the lancer has any advantage over the swordsman, Vangnard's remarks are absolutely conclusive. Nobody but Dundas ever supposed the possibility of two lines of cavalry coming in positive and simultaneous contact; one or other must either give way, turn about, and fly, or else, falling into disorder, be penetrated and passed through, so as to produce a complete *melee*, in which that party which first regains any degree of order, will have the instant advantage. This is the moment when the *arme blanche*, as the French call it, really comes into play, and by no means in the act of charging, when the strength of the horse's legs has a far greater effect than the vigour of the rider's arm. Now, in this *melee*, let us consider which will be best off; the lancer or the swordsman? the long weapon or the short? opinions, and good opinions, too, are much divided upon this point. It has been proved by several trials, that a single lancer on a very well-broke horse, is more than a match for a single swordsman, supposing them both expert at their respective arms, and fairly pitted one against the other, without the presence of other combatants, in a clear space, and on even ground, where the lancer can have the full benefit of his horse's activity. In these mock combats for the sake of trial, the lancer has not, however, been allowed all those advantages which he would have had in the field of battle, because with the foil-lance, used on such occasions, he cannot of course be permitted to strike his adversary's horse, but only that adversary himself. Now, there is hardly any horse that could be brought again to face the lancer, or even prevented from turning short round, and completely exposing his own rider to his attack, when once it has received upon the nose one of those tremendous blows which can be given with the staff of the lance by swinging it round with the whole strength of the arm, and by means of which men who are good masters of the weapon will actually strike a man clean off his horse if they get a fair stroke at him in this manner.

Having now given fair credit to the lance as opposed to the sword, when both are wielded by skilful antagonists, let us consider the much more ordinary case of an indifferent lancer opposed to an indifferent swordsman, both mounted on horses hastily trained, as must often happen in time of war, perhaps equally fatigued with long marching and out of heart by scanty forage and exposure to weather. A wide difference will be found in this case from that which we just now proposed for consideration. A bad lancer is a much more clumsy fellow than a bad swordsman; not only is his weapon by far the most difficult to manage, but his powers of horsemanship are materially affected by his awkwardness in attempting to wield it; and if in addition to this, the scene of the combat happens to be in deep and uneven ground, his chance of success against the swordsman, however indifferent may be the skill of the latter, becomes more than questionable.

As to the idea of lancers being at all more formidable than any other cavalry to infantry in square, as long as that square maintains its formation, every officer of service or judgment must at once agree fully in Vanguard's observation, as to the invincibility of a square by any

cavalry weapon, whether long or short. If lances could be carried twice or even three times as long as at present, still the storm of "iron sleet" issuing from the square, must reach the lancer before his point can reach its ranks; and even if he could pike one man in the kneeling rank, there are more behind to avenge their comrade's fall, by returning lead for steel with good interest.

But, besides the lancer and his infantry antagonist, there is yet another party concerned in the matter, who is of considerable importance. This is no other than the lancer's horse, who, though by the force of habit, and the nobleness of his docile, but undaunted spirit, he is readily trained by gentle treatment

"Sub armis,
Insultare solo, et gressus glomerare superbos,"

in the serried squadron, against the ordinary array of war in almost all its forms; yet, when he is urged against the terrible face of the infantry square, more resembling a living volcano than any phalanx of human invention, when his sight is obscured by clouds of rolling smoke, only broken by the quick flash of the musket and the occasional gleam of the bayonet, the animal becomes bewildered with terror, and wheeling round, in spite of reign and spur, rushes from the unequal conflict, where he seems to know almost by instinct that his destruction is instant and inevitable. Let any one, officer or soldier, who has ever charged a square, deny, if he can, the truth of this picture. Nay, let the experiment be tried of how near a squadron of cavalry can be brought to a square of the foot-guards, firing blank cartridge in Hyde Park, and the thing will speak for itself, putting out of the question the concentrated and incessant shower of bullets by which that square has before now taught the finest cavalry of France a severe and bloody lesson.

By those few officers of either arm, who deny the invincibility of the square, the extraordinary and solitary instance is quoted of the charge of Bock's heavy Germans in Spain; but he it recollected that, in that desperate affair, the French square, before it gave way, laid sixty of its assailants upon the ground, and was itself under the discouragement of retreat, and attempting to continue its march towards the rear, so that its order was by no means perfect; indeed, it is said, that the front rank could not be induced to kneel by their officers, who used the strongest entreaties and threats to prevail upon them to do so.

The lance then, in ordinary hands, and on ordinary occasions, cannot claim any advantage over the sword, either for the charge against cavalry, or for the attempt at breaking into the infantry square. Against broken and fugitive infantry, there can be no doubt, however, that it is the most destructive of weapons. But does this counter-balance, as regards the British cavalry service, the great evil of being without fire-arms? for the pistol is, as has been before observed, a very bad substitute, or rather no substitute at all, for the carbine. This question would soon be decided by the officers themselves of our lancer regiments, after a very short period of continental war. Mortified as they would soon find themselves in being debarred by the nature of the weapon carried by their men, from those active duties of the out-posts, which, besides forming the young officer in the most essential business of his profession, give him frequent opportunities of advan-

tageously displaying his zeal and intelligence, the officers of the lancer regiments would very soon ask, as the greatest favour, to be allowed to lay aside the lance for the carbine, in order to obtain an equal chance of distinction with the rest of the cavalry.

Now it may, perhaps, be answered that, as the lancer regiments are in all other respects admirably equipped as regards both man and horse for the purposes of light cavalry, it will be time enough when the day of trial comes to exchange the lance for the carbine, if the experience of service should prove the necessity of such an alteration. But this is a dangerous reasoning. The war in the Peninsula gave a very fair test of what is wanted of our cavalry; and would the Duke of Wellington at any period of that war have consented to exchange a regiment of dragoons, either heavy or light, for a regiment of lancers? This is a proper opportunity, by the by, for calling the notice of our cavalry chiefs to a point which, in time of peace, is never sufficiently considered—namely, the great importance of giving more time and attention in our dragoon and hussar regiments to the use of the carbine on horseback. One of our hussar colonels has invariably followed the judicious practice of making all his men act in their turn as skirmishers at field days; but a great number of regiments content themselves with merely selecting in each troop a few of the most active men and horses as permanent skirmishers, to rush out from the ranks at full gallop for mere effect and display, and return, after firing off their carbines half a dozen times in the air, at the same unnecessary speed with which they went out. This method of skirmishing affords no instruction whatever towards making even the selected soldiers *good shots* with their fire-arms; and as in the riding-school the pistol alone is used in firing at a mark, the greater proportion of each troop may go on from one year's end to another without a single opportunity of even knowing whether they have any dexterity or not in the use of the carbine on horseback. There are, no doubt, a certain number of parades for ball-practice on foot, but a man who is a tolerably fair shot on his own legs, may find himself as much puzzled upon a shy or hot-tempered horse, as a horse-artillery-man would be perplexed to take a good aim with an 18-pounder in a heavy sea on board of ship.

At many of our cavalry stations there is no ground where, even on foot, this ball practice can take place; but surely, wherever it is possible, the men should invariably fire at the target from on horseback, instead of being dismounted for that purpose.

Some of our officers, who are anything but deficient in either theory or experience, have answered these remarks upon making the men marksmen with the carbine, by saying that the horses soon get steady enough after undergoing a few of the fatigues and privations of service, and the soldiers learn better from the enemy how to skirmish, and use their weapons, than they can possibly be taught at home; but surely it should not be forgotten that, from our situation as an insular nation, the campaigns of our armies most frequently begin on the very beach where our armies disembark, and that the first success, however trifling, is of the utmost moral value as regards its effect upon the troops in general. Now the outpost cavalry are in all likelihood the first who will be engaged; and to find themselves possessed of a decided superiority in skirmishing, from expertness previously acquired in the use of their fire-arms, must naturally be of the greatest encouragement to

them ; while, on the other hand, to find by an unpleasant sort of proof, that they have been neglecting a point of instruction upon which they now discover that so much of their success must depend, cannot fail to produce a disheartening effect. "*Fas est et ab hoste doceri,*" is a very wise maxim, no doubt ; but to learn to shoot by being shot, is a kind of *instruction mutuel* which can never be made at all palatable. To return, from what it is hoped will be considered a pardonable digression, to the subject of lancer regiments, and their utility for general purposes of service, it may be well to notice, that suggestions have lately been made, by good authorities, of the propriety of supplying the lancers with a certain number of carbines to each troop, by which arrangement those regiments would certainly be rendered much more available than at present, and at all events would be able to protect themselves in marching through difficult or enclosed country, unaccompanied by other troops.

Still this would not enable them to be as useful as dragoons or hus-sars, when forming part of an army in the field. It is not only necessary for cavalry to be able to take care of themselves, but their principal use is, after all, to watch over the security of the infantry, who look to the patrol and picquet of cavalry for relief from fatigue, and for repose from the harassing watchfulness which would otherwise be required of them, without any intermission, in the presence of an active and enterprising enemy.

Before taking leave of a discussion which contains much of interest for the cavalry officer, there is one great merit of the lance which must not be forgotten. Of all the means of making a man active and well-seated on horseback, the use of this weapon in the riding-school is beyond comparison the best. A man who, without stirrups, and mounted on a horse with a fine mouth, can wield a lance with facility, and go through the exercise, without disturbing his bridle hand, or in any way agitating the animal by want of balance in his saddle, must of necessity be an excellent military rider ; and yet it requires no very tedious process to bring a recruit to considerable proficiency in using the lance sufficiently well on horseback to make him derive great advantage from it in this respect. To alter this, or any other part, (except, perhaps, the slow canter,) of our present riding-school system, would be a great pity. Those officers who are either so prejudiced or so ignorant as to despise the art of military horsemanship, are little aware of the astonishing improvements that have been produced by its study of late years in the British cavalry ; improvements from which many excellent results may be anticipated whenever they again are summoned to the field, as well from a mild mode of treatment of the horse, which must greatly tend to his duration, as from the much greater steadiness in the ranks, and susceptibility of control, which is the consequence of giving the soldiers good hands and increased ease and readiness in the management of their horses. Both to Vanguard and the lancers some apology is, perhaps, due, for the freedom with which the remarks of the former, and the arms of the latter, have been discussed ; but a moment's consideration will convince them that the views here offered to the military public, can only arise from a zeal of which they themselves so largely partake, for the advantage of one of the most important branches of the service.

THE DRUMMOND LIGHT FOR ILLUMINATING
LIGHT-HOUSES, &c.

LIEUT. THOMAS DRUMMOND, of the Royal Engineers, has the merit of having discovered a combination by which a light is produced, so intense and pure as to promise the most fortunate results in its application to the important object of light-houses. This valuable discovery has been submitted to the test of experiment with complete success; its superiority to light produced by any previously existing process, as well as its practical effects, having been triumphantly established.

In a paper submitted to the Royal Society by Colonel Colby, Mr. Drummond describes his invention, suggested by his previous attempts to produce a light sufficiently brilliant to mark distant stations in surveys, first tracing the various clumsy modes of illuminating light-houses, down to the improved method by MM. Arago and Fresnel, recently introduced in France. The latter plan consists of an octagonal arrangement of powerful lenses round a large Argand lamp, of four concentric wicks, the light of which, by means of a coping or roof of minor lenses in the form of trapezoids, inclining at angles till they meet above, is thus completely enclosed. We must repeat by the way, the just animadversion of that officer upon the retention of a defective principle in the solitary instance of the North Foreland Light, where the expedient of a glass lens placed before a parabolic reflector (or rather *vice versa*, according to the original device,) is still suffered to mar the intended result, the effect of the reflector *alone* doubling that of the reflector and lens *united*.

After detailing the two methods at present in use—viz. 1st, Parabolic reflectors, illuminated by an Argand lamp, the process being modified to meet the construction of the light, whether fixed or revolving; and 2nd, the French mode of M. Arago, referred to above,—Mr. Drummond observes:

“Such are the methods at present in use in the best light-houses of Great Britain or France. The third and last method is that which I have ventured to propose, and in which the light is derived from a source altogether different from the preceding two; a ball or cylinder of lime, intensely ignited,” by directing upon it a stream of mingled oxygen and hydrogen gases, “being substituted for the Argand lamps.

“Fig. 1. represents the lamp. The two gases, oxygen and hydrogen, proceeding from separate gasometers, enter at *o* and *h*, but do not mix till they arrive at the small chamber *c*, of which fig. 2. is a section: into this chamber the oxygen gas from the inner tube is projected horizontally through a series of very small apertures, and the hydrogen gas rises vertically through a series of similar apertures at *d*. The united gases then pass through two or three pieces of wire-gauze placed at *e*, and being thus thoroughly mixed, issue through the two jets against the ball *b*. To prevent the wasting of the ball opposite the two jets, and at the same time to diffuse the heat more equably, it is made to revolve once in a minute, by means of a movement placed underneath the plate *m*, and with which the wire *f*, carrying the ball and passing through the stem, is connected. Notwithstanding, however, this arrangement, the effect of the heat is such as gradually to cut a deep groove in the ball, so that at the end of about forty-five minutes it becomes necessary to change it. In a light-house, where it is of essential consequence to maintain a constant light, it would be unsafe to entrust this to



Fig. 1.

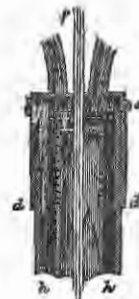

Fig. 2.

an attendant, and hence the necessity of devising some means for remedying this inconvenience."

This has been done by an ingenious and effectual contrivance.

Having described his apparatus, which is accurately designed to combine the mechanical action of his plan, Lieut. Drummond next details the results of experiments, made at the Trinity House, on the intrinsic intensity of the different lights. These highly favourable results,—deduced from exact comparative calculations, which are given, and from which we learn that the light emitted by a lime-ball only three-eighths of an inch in diameter, heated by two jets, is equal to thirteen Argand lamps—

"Were obtained by screening the different lights, and then placing equal apertures opposite each, changing the apertures and taking the mean to destroy the effect of any inaccuracy in size. The intensity of the lime-ball being therefore 264 times that of the Argand lamp, a single reflector illuminated by the former will be equal to 264 reflectors illuminated by the latter; but the divergence of the reflected light, depending upon the size of the luminous body in the focus, will be smaller with the ball than with the lamp in the proportion of about three to eight; hence, in such a light-house as that of Beachy Head, eight reflectors may be substituted for thirty, and yet an effect would be produced twenty-six times greater than that of the present light, the most perfect of its kind in this country.

"By similar experiments it was found that the French lens was equal to 9.1 reflectors; and if the effect of the additional lenses and reflectors which ought to accompany it, and which has been estimated at one-seventh, be added, then the lens is equal to 10.4 reflectors. In like manner, therefore, the effect of a single reflector with a lime-ball would be equal to twenty-five times that of such a combination of lenses.

"It may now perhaps be asked, at what expense can such a light be maintained? Can the gases by which the requisite heat is produced be procured at such a price as to compete with oil or coal gas? The data I possess for forming an estimate of the expense of the gases are very scanty, but the quantity consumed was accurately determined; at the same time the consumption of the other lights was also tried, and the results are as follow:—

	Consumption in 3½ hours.	Expense per hour.
An Argand lamp seven-eighths of an inch in diameter	1 gill . . .	0.69 penny
The same placed in a reflector . . .	1½ gill . . .	0.83 penny
The French lamp	2 qts. ¼pt. . .	1s. 2½d.

"The lime requires four cubic feet of hydrogen and two of oxygen per hour, and the probable expense is 5d per hour.

"In a revolving light of the first class, containing thirty reflectors, the expense per hour would therefore be about 2s. 1d. If the French method were employed, the increase of light would be $\frac{1}{20}$ th, and the expense only 1s. 2½d. per hour. If six reflectors illuminated with lime-balls were used, which would probably be sufficient, the probable expense would be 2s. 6d. per hour, and the increase of light twenty-six times.

"The experiments at the Trinity House being concluded, the whole of the apparatus was removed to Purfleet, where on a knoll of chalk about 100 feet above the river a temporary light-house had been erected, and being fitted with the requisite machinery, the different lights were made to revolve in succession, and the appearance which they presented, as well as the duration of the light, were observed from the Trinity Wharf at Blackwall, a distance in a straight line of 10½ miles.

"The four faces of the revolving machine were thus occupied:

"No. 1. A single reflector twenty-one inches diameter, three inches focal distance, with an Argand lamp.

"No. 2. Seven reflectors, with ditto.

"No. 3. French lens, with its lamp.

"No. 4. Single reflector with lime-ball.

"The respective lights were accurately placed in focus.

"When No. 4, the reflector lighted with the lime-ball, was turned towards the

Wharf, the light was so great that the shadow of the hand and fingers was distinctly visible even on a dark brick wall, while no such effect was discernible when the other lights were turned in the same direction.

“ In order more justly to estimate their comparative effects, No. 4, was removed to a temporary tent about twenty-five yards to the right of the light house, as far as the edge of the cliff would permit, and on the evenings of the 25th and 31st May regular series of experiments were made. Being engaged at Purfleet, directing these exhibitions, I never had an opportunity of witnessing their effects at Blackwall; but Captain BASTI. HALL, R.N., who from the interest which he took in these experiments was an attentive observer of all that occurred, has at my request kindly favoured me with the following interesting account :—

“ My dear Sir,

“ 4, St. James's Place, 1st June, 1830.

“ You wished me to take particular notice of last night's experiments with the different kinds of lights exhibited at Purfleet, and observed at the Trinity Wharf, Blackwall; but I have little to add to what I told you respecting those on the evening of the 25th instant: indeed it is not within the compass of language to describe accurately the details of such experiments, for it is by ocular evidence alone that their merits can be understood.

“ Essentially the experiments of last evening were the same as those of the 25th, and their effects likewise. The degrees of darkness in the evenings however were so different, that some particular results were not the same. The moon last night, being nine or ten days old, lighted up the clouds so much, that even when the moon herself was hid, there was light enough to overpower any shed upon the spot where we stood by your distant illumination: whereas on the 25th, when the night was much darker, the light cast from the temporary light-house at Purfleet, in which your apparatus was fixed, was so great that a distinct shadow was thrown upon the wall by any object interposed. Not the slightest trace of any such shadow, however, could be perceived when your light was extinguished, and any of the other lights were exposed in its place.

“ In like manner on the evening of the 25th, it was remarked by all the party at the Trinity Wharf, that, in whatever direction your light was turned, an immense coma, or tail of rays, similar to that produced by a beam of sun-light in a dusty room, but extending several miles in length, was seen to stream off from the spot where we knew the light to be placed, although, owing to the reflector being turned too much on one side, the light itself was not visible.

“ Now, last night there was none of this singular appearance visible; but whether this was caused by the presence of the moonlight, or by the absence of the haze and drizzling rain which fell during the evening of the 25th, I cannot say. I had hoped that the appearance alluded to was to prove a constant accompaniment to your light, in which case it might, perhaps, have been turned to account for the purposes of light-houses. If in hazy or foggy weather this curious effect of reflected light from the atmosphere be constant, it may help to point out the position of light-houses, even when the distance of the observer is so great that the curvature of the earth shall render it impossible for him to see the light itself.

“ The following experiments tried last night were the same as those of the 25th, and certainly no comparative trials could be more fairly arranged.

“ EXPERIMENT I. The first light exposed was the single Argand burner with a reflector. This was quite distinctly seen, and all the party admitted it to be a good light. After several minutes this was put out.

“ EXP. II. The seven Argand burners were next shown, each in its reflector: and this was manifestly superior to the first; but how much so I cannot say, perhaps four times as conspicuous. Both these lights had an obvious tinge of brown or orange.

“ EXP. III. The third light which was exposed, (on the seven Argands being put out,) was that behind the French lens; and I think it was generally admitted by the party present, that this light was whiter and more intense than that from the seven Argands, though the size appeared very much the same.

“ EXP. IV. The fourth light was that which you have devised, and which, instead of the clumsy word ‘Lime,’ ought to bear the name of its discoverer. The Drummond light, then, the instant it was uncovered, elicited a sort of shout of admiration from the whole party, as being something much more brilliant than we

had looked for. The light was not only more vivid and conspicuous, but was peculiarly remarkable from its exquisite whiteness. Indeed there seems no great presumption in comparing its splendour to that of the sun; for I am not sure that the eye would be able to look at a disk of such light, if its diameter were made to subtend half a degree.

“ ‘ The next series of experiments was the most interesting and decisive of all. Each of the lights above enumerated, viz. the single Argand burner, the seven Argands, and the French lens, were exposed, one at a time, in company with your light, in order to try their relative brilliancy.

“ ‘ First comparative Experiment.—The single Argand burner was first exposed to this comparative ordeal, and nothing could be more pitiable than the figure it cut. Many of the party could not see the Argand light at all; while others could just detect it ‘ away in a corner,’ as some one described it. It was also of a dusky orange tinge, while your light was of the most intense whiteness.*

“ ‘ Second comparative Experiment.—The seven Argand burners were now substituted in place of the single light. All the party could now see both lights, but the superiority was not much less obvious. I really cannot affix a proportion either as to size or brilliancy; but I should not hesitate to say that your light was at least six or eight times as conspicuous; while in brilliancy, or purity, or intensity of light, (for I know not precisely what word to use to describe the extreme whiteness,) the superiority was even more remarkable. All this which I have been describing was expressed, and appeared to be quite as strongly felt by the rest of the company, to the number, I should suppose, of five-and-twenty or thirty persons, who were all closely on the watch.

“ ‘ Third comparative Experiment.—The next comparative trial was between the French lens and your light. The superiority here was equally undeniable; though the difference in the degree of whiteness was not so remarkable. The French light, however, is so nearly similar to that from the seven Argands, that the comparison of each of them with your light gave nearly the same results, and all equally satisfactory on the score of your discovery.

“ ‘ Final Experiment.—The flashes with which the experiments concluded were very striking, and might, I think, be turned to great account in rendering light-houses distinct from one another. The revolutions were not effective, and, as I said before, there was no appearance last night of those enormous comets’ tails which swept the horizon on the night of the 25th, to the wonder of all who beheld them: neither could there be detected the slightest trace of any shadow from the light thrown towards us, and I suspect none will ever be seen, when the moon, whether the night be clouded or not, is of so great a magnitude.

“ ‘ Such is the best account I can give of what we witnessed; and I need only add, that there seemed to be amongst the company but one opinion of the immense superiority of your light over all the others brought into comparison with it.

“ ‘ I am, &c.

“ ‘ BASTL HALL.’ ”

From the vivid and pervading quality of this light, it becomes a question worth consideration, whether it might not be applied, in a more permanent form, to the purpose so incompletely effected by fire-balls in the defence of besieged fortresses. Might not Drummond lanterns or reflectors be so contrived as to search the defences obliquely, without exposing their disks to the view and aim of the assailants?

It is unnecessary to remark that these experiments and testimonies are conclusive as to the principle and practical effects of Lieut. Drummond’s discovery. To smooth all difficulties of execution, reduce expense, and divest his plan of technical intricacy, so as to render the superintendence of his lights nearly as simple a task as the trimming of a lamp, are objects which, we have reason to believe, at present engross the attention of that meritorious officer. Of his complete success we have no doubt, and heartily congratulate him upon having conferred a benefit upon his country and mankind.

* To many, the rays from the brighter light appeared, when seen with the naked eye, to extend across and envelope the fainter light, though the perpendicular distance between them was twenty-five yards.

MEMOIR OF
FIELD-MARSHAL COUNT VON DIEBITSCH SABALKANSKI.

WHILE we have gathered from public records a portion of the details traced in the following memoir, we acknowledge ourselves still more indebted to communications derived from some of the nearest relatives of its subject.

JOHN CHARLES ANTONY VON DIEBITSCH AND NARDEN, is descended from an ancient and noble Silesian family, and was born on their estate at Gross-leippe, on the 13th of May 1785. His father, *John Ehrenfried von Diebitsch and Narden*, had made the campaigns of the Seven Years' War on the staff of Frederick the Great, and, after having been promoted by his successor to the rank of lieutenant-colonel and adjutant on his staff, had retired to his patrimonial estates, when he was induced to accept the superintendence of the manufactory of arms at Toulza, from which appointment he was subsequently raised to the rank of major-general. By a first marriage he had two sons, one of whom is at this day a colonel in the Russian service; and by a second, three daughters, and a third son, the individual, with whose fortunes we shall proceed exclusively to engage the reader's attention.

In his earliest years, John Von Diebitsch displayed not only an ardent thirst for information, but so singularly retentive a memory, that, when but in his fourth year, he was capable of resolving arithmetical questions with greater readiness than most adults. His first rudiments of knowledge were acquired from a village schoolmaster, whose capabilities soon proved insufficient for the stripling's ardent intellect; his parent, therefore, a man of no mean attainments, was compelled to undertake the duty of an instructor, and evinced his fitness for the office by guiding the mind of his pupil in those paths of geographical, historical, and mathematical knowledge, to which he sacrificed even the hours of daily recreation. No pursuit, however, so excited young Diebitsch's ardour as that memorable episode in the annals of his native country—the Seven Years' War; and hence undoubtedly arose his early predilection for a military life. It was natural that his teacher, himself a soldier, as well as a sharer in the exploits of the first soldier of his age, should foster this predilection, and avail himself of so auspicious an occasion for exhibiting the theories of physical and mathematical science in the perfection of their practice.

As he advanced in years, the youth felt anxious for a society more congenial with his favourite pursuits, and his father, at length yielding to his importunities, removed him to Berlin, with a view to procure his admission into the corps of Cadets. This occurred in 1797. His age, however, which was not much beyond twelve years, threw such difficulties in the way, as nothing but the perseverance of the youth himself, combined with his attainments, of which he gave the most unexpected proofs when under examination, could have overcome. But the mere wearing of a sword and military frock, though it gratified his pride, had no value in his eyes except as the first step towards distinction: he devoted himself with single-hearted assiduity to an arduous course of regular study; and raised himself into notice among his comrades by the rapidity of his progress in acquiring military knowledge, and into respect with his superiors by the exemplary regularity of his conduct and his amiable deportment. In the course of two years he became a subaltern officer in the corps, and, soon afterwards, was honoured with an ensign's sword.

In the mean time, his father had accepted a major-generalship on the staff of Paul of Russia, upon whose personal intercession, the King of Prussia allowed young Diebitsch to resign his commission as a second-lieutenant, in the early part of 1801. He had quitted the corps of Cadets in the preceding year, and it is a curious fact, that, on this occasion, he should have inscribed

the undermentioned lines in the album of his favourite tutor, Bardeleben, one of the council to his Prussian Majesty.

Ja, vergehen muss, vergehen
Pfaffenthum und Mahomed;
Rauchen werden ihre Trümmer
Wenn die Freundschaft noch besteht.
Berlin. Anno 1800.

Yes! Papal Rome and Mahmoud's pride(!)
Shall from this scene be swept away;
And from their waste the smoke ascend
Ere friendship's glow has lived its day!

His relinquishment of the Prussian service was accompanied by the sincere regret of his superiors and tutors, and he carried with him an honourable testimonial to his character and uncommon attainments, under the hand of Gen. Von Rüchel, the commandant of the corps of Cadets. From Berlin, he proceeded to Stettin with his father, who had come to that city for the purpose of conveying his sister and himself to Russia, and thence embarked for St. Petersburg, where they arrived shortly after the accession of the Emperor Alexander. The elder Diebitsch's merits were not unknown to that sovereign; and the best proof he could afford of his esteem, was the permitting his son to make choice of the regiment in which he would be posted. The result was an ensign's commission in the Semenoff regiment of Grenadier Guards, which Alexander had commanded when Grand-duke. Diebitsch at once determined upon becoming a Russian in word as well as in deeds, mastered the peculiar difficulties of the language so as to speak and write it like a native, and thus identified himself with his brother soldiers. His first active service was to attend the Emperor's coronation at Moscow, whence he returned with his regiment to garrison duty at St. Petersburg; here he devoted every leisure hour he could spare from military avocations to scientific and professional pursuits, until the war of 1805 called him to the field of battle, and raised him to a lieutenantancy. The sanguinary day of Austerlitz was the dawn of his martial feats; but here he was doomed to behold the Muscovite eagle laid prostrate; an untoward introduction to so early a noviciate in arms. His own company was involved in the heat of the conflict, during which a spent ball lodged in the palm of his right hand; he was observed to bind the wound quietly with his handkerchief, remove his sword into his left hand, and, regardless of pain and loss of blood, to rally his men, who had been bereft of their leaders by the fortunes of the day, and lead them out of the field, upon general orders being given for the army's retreat. Diebitsch's gallantry on this occasion was rewarded by Alexander with a sword of honour, bearing the words, "Conferred for bravery." The unfortunate issue of this battle brought the campaign to a sudden close, and the disappointment of the soldier was rendered still more bitter by the affliction which he endured as a son, on learning that his mother had breathed her last shortly before his return to St. Petersburg.

In 1807, the Russian hosts were again in the field; a new opportunity of distinguishing himself presented itself on the plains of Eylau and Friedland; and in both actions his conduct was so exemplary, as to induce the Emperor to raise him to a captaincy over the heads of his brother-officers, and honour him with the Order of St. George of the Third Class; to which the Prussian Sovereign soon afterwards added the order of "Merit." Thus had Diebitsch scarcely reached his twenty-second year, when four distinct acknowledgements of meritorious service had been conferred upon him. From this period until the eventful year 1812, his chief employment consisted in sedulously prosecuting those studies which, conjointly with the aptitude of his natural talent, were to form the corner-stone of his rapid advancement.

Napoleon was already on the march with his myriads towards the Russian frontier, when young Diebitsch, resting his claim on his attainments and former services, solicited a post on the general staff. This request was granted, and, with it, the rank of a lieutenant-colonel, in which character he was attached to the division under the orders of his old and esteemed friend Gen. Wittgenstein. From this point we may date the commence-

ment of his more brilliant career. His station on the staff placed within his reach abundant opportunities of acquiring quick-sightedness, caution, and experience; qualities, in the absence of which, the most consummate theoretical acquirements are but of indifferent value and restricted usefulness.

Wittgenstein's corps was pitted against the superior force under Oudinot, and speedily constrained to fall back from Wilkomirz upon a position, in which it was enabled both to cover the Russian capital and obstruct the investment of Riga. In this position he had to contend against the combined efforts of the Dukes of Tarentum and Reggio, with both of whom it was an object of the deepest moment to possess themselves of the great northern inlet to St. Petersburg. The Russian commander, however, skilfully contrived to interpose between the two lines of his adversaries' movements, to maintain his ground upon the Dwina, and, in the conflicts of Jacobowo, Obojarzina, and Kliastizza, to bridle the impetuosity as effectually as he had baffled the skill of his assailants. The French were driven back upon Polozk, and whilst honours were heaped upon the victor, Diebitsch, the life and soul of his *état-major*, was not forgotten. A major-generalship and the ribbons of more than one order were his reward.

Towards the close of October, Wittgenstein received sufficient reinforcements to enable him, as a step towards forming a junction with the Finnish corps under Gen. Stringel, to act upon the offensive; accordingly, he advanced against Polozk, expelled the French, of whom Marshal St. Cyr had taken the command, from that town, and obliged them to recross the Dwina, after a sanguinary action, in which Diebitsch, by gallantly forcing and maintaining a bridge at the head of 3000 raw peasantry, entirely disconcerted the French plan of attack, and, by this service, is considered to have decided the issue in favour of the Russian arms; in fact, it was on this spot that he earned his commission of Major-General. The severe conflicts of Czaśnicki and Smoliani subsequently contributed to the precipitate retreat of the enemy, who were pursued by Wittgenstein to Studzianka, and were unable to prevent Parthonneaux's division from falling into his hands. The French and their Allies were now flying in all directions; and the Prussian corps alone remained together to cover them in their retreat, and upon Gen. Diebitsch devolved the painful duty, not only of measuring weapons with his own countrymen, but of entering his native land as a victorious adversary. It is needless to say, that he acquitted himself in this trying circumstance with a caution and delicacy to which his natural sovereign has since rendered ample justice; indeed, they pointed him out soon afterwards as the fittest individual who could be selected to open and conduct a negotiation with the Prussian commander. Previously, however, Gen. D'York, whose force constituted the third column, or rear-guard, of the feeble remnant of the French army, had been driven out of Mietau, and on the 27th of December following, forced to evacuate Memel; from this place Diebitsch kept close upon his heels, having an internal presentiment that the Prussian possessed secret instructions, which would justify him in seeking the first favourable opportunity of arresting any farther effusion of blood. The uncertainty, in this respect, called for the exercise of much discretion; Diebitsch made his dispositions accordingly, and, indeed, with so happy an effect, that, although at the head of no more than 1800 horse, he deceived D'York into an impression that, when he was signing the celebrated capitulation of the 30th of December 1812, the whole corps of Wittgenstein stood before him. It subsequently appeared that D'York had no instructions from his cabinet, but acted, on this occasion, upon his individual responsibility, and a personal conviction that a close alliance with Russia would best conciliate the interests with the avowed prepossessions of their common country.

For this service Diebitsch received the cordial thanks of the Emperor Alexander, accompanied by the insignia of the Order of St. Anne, of the first class; and he entered Berlin with the rank of Quarter-Master-General. Here was no slender proof, that if he had been blessed with those op-

portunities which a soldier covets, he had wanted neither the good sense nor ability to turn them to a rich account. Of eight-and-twenty years of a well-spent life, thirteen had elapsed since he had visited the land of his birth; and under what stirring circumstances of delight and satisfaction with the fruits of his toil, must he not once more have trodden its soil?

In the year 1813, he replaced Gen. Davvy as chief of Wittgenstein's staff; the Russian army was, however, checked in its career by the loss of the battle of Bautzen, and a change in its organization, after it had fallen back upon Silesia, brought Diebitsch under Barclay de Tolly's orders, as Quarter-Master-General of the first *corps d'armée*. But the armistices which ensued afforded him full occupation in another sphere of action. It was required of the Emperor Francis to decide, whether he would persist in supporting his son-in-law, or make common cause with those who had confederated to rid themselves of the galling yoke of French domination? Diebitsch's adroitness as a negotiator had been tried and proven; he was entrusted with full powers on the part of Alexander, repaired to Reichenbach, and, on the 14th of June 1813, was a subscribing party to the secret treaty between Austria, Russia, Great Britain, and Prussia, which was finally settled and ratified at Trachenberg on the 9th, 10th, and 11th of July following. On the latter occasion, he was likewise instrumental in arranging the plan of operations for the ensuing campaign; and his merits were acknowledged so liberally by the Austrian and Prussian courts, that on his return to head-quarters, no fewer than eleven Orders glittered upon his breast.

This peaceful scene of diplomatic triumphs was succeeded by the cares and tumults of war. Napoleon quietly waited the advance of the confederates upon Dresden; the hard-fought contests of the 26th and 27th of August revived his drooping hopes, and ridded him of a hated and powerful rival,—the lamented Moreau. In this conflict, Diebitsch distinguished himself by his usual gallantry; after having had two horses killed under him and received a severe contusion, he continued at his post in the thickest of the fray, and took a conspicuous lead in superintending the retreat. At the subsequent battle of Culm, he was placed in the singularly-painful predicament of being checked in a charge at the head of some regiments of cavalry, by the murderous fire of a division of Prussian infantry, who mistook them for their French opponents; and in the memorable "struggle of nations," as our German neighbours term it, which was held in the plains of Leipzig, the skill, precision, and intrepidity, with which he led the movements entrusted to him, were of so distinguished a character, as to induce the Emperor Alexander to name him one of his lieutenant-generals on the field of battle, and procure him additional marks of princely favour, amongst which was the Prussian Order of the Eagle of the first class.

The war was now transferred into the bosom of the oppressor's dominions. In March 1814, the Allies had penetrated as far as Provins; but St. Priest had been worsted and Rheims retaken; they retreated to Arcis-sur-Aube; and here, in a moment of panic, Alexander and Frederic William consented, in a council of war, that Schwartzenberg should fall back upon Bar and behind the Aube. The head-quarters were consequently removed to Troyes, and the whole army had orders to follow on the ensuing day. Diebitsch was one of the very few who foresaw the inevitable perils of so precipitate a change from the offensive to the defensive; to retreat was to throw the whole moral and physical resources of the country once more into the adversary's scale. In vain had he urged remonstrance after remonstrance upon the Generalissimo; he sought his own Sovereign, and, with the eloquence of deep conviction, succeeded in persuading him that "to fail before Paris would be less costly in consequences than to retire behind the Rhine, and that, in the worst event, a retreat upon the Dutch frontier remained at their command, where they would effect a junction with the unfeebled forces under Bülow." A second council was called together, and in that eventful night, of which Alexander declared that "he thought his hair

would have grown half-grey," the retreat was countermanded, and orders for resuming the offensive were given. On the 31st of March, the Allied army marched through the gates of Paris, and on the summit of Mont Martre, the Emperor Alexander clasped Diebitsch in his arms, expressed his grateful acknowledgment of the eminent services he had rendered to the common cause, and with his own hand invested him with the ribbon and insignia of St. Alexander-Newsky,—the highest distinction which Russian chivalry affords.

As soon as peace was concluded, Diebitsch found his way back to Warsaw, and on the 31st of March 1815, he married Jane Baroness de Tornau, a daughter of the Baron and Privy-Counsellor of that name, and niece to the lady of Prince Barclay de Tolly, under whose immediate eye the latter years of his bright career had been passed. Of this marriage there has been no issue; and he is at this moment in the first year of his widowhood.

On Napoleon's return from Elba, Alexander called him to his side at the congress of Vienna, and then sent him to join the first corps of the Russian army, as chief officer of the general staff. After the battle of Waterloo, Count Woronzow's division being left to form part of the army of occupation, the remainder of the Russians bent their way homewards, and Diebitsch proceeded with his corps to the Dnieper, where he remained in headquarters at Mohilew, until the Emperor gave him a farther proof of his confidence by appointing him Adjutant-general. When the Spanish and Italian revolutions called the Sovereigns together at Laybach, Diebitsch was specially summoned to accompany his Monarch to the congress, and was one of his principal advisers throughout its proceedings. Upon their termination, he returned to Mohilew, where he remained stationed, until he was ordered to St. Petersburg in the year 1820, and placed at the head of the Imperial staff. In this capacity, and as Adjutant-General, he was attached to his Sovereign's person in the strictest sense of the word, accompanied him on all his journeys, and was consulted upon every occasion where the army or military affairs were concerned. His influence was also enhanced by his appointment to the Major-Generalship of the Russian forces.

In the autumn of 1825, the Emperor Alexander set out upon a tour of inspection through Podolia, Wolhynia, and Bessarabia, and having joined the Empress at Taganrog, on the Sea of Asoph, thence made excursions into the Crimea and several adjacent provinces. Diebitsch was his favourite companion. Sebastopol was one of the places they visited, and its rich and delightfully romantic scenery excited the Emperor's admiration in so lively a degree, that he suddenly turned round to Gen. Diebitsch, and exclaimed—"Should I ever withdraw from the cares of government I should wish to close my days on this spot." He had not been long at this place before he complained of cold and general indisposition, returned in consequence to Taganrog, and, after some fourteen days' illness, expired, on the 1st of December, in the arms of his exemplary consort. Diebitsch, having witnessed this scene with a sorrowing eye, and wept many a bitter tear over the last remains of a kind and beloved master, hastened back to the Russian capital.

The faithful servants of the elder were welcome guests in the presence of the younger brother, and Diebitsch found in Nicholas a patron who was capable of appreciating his merits and devotion. The young Prince was scarcely engaged in providing for the conduct of the Government, when he was called upon to defend the throne against a widely-ramified conspiracy, of which the seeds had been laid so far back as the year 1821. It was, however, averted by the resolute energy of the Regent, and Miloradovitsh, Governor of St. Petersburg, who fell its first and most distinguished victim. Among the numerous list of those who were thus rescued from its vengeance, was Gen. Diebitsch, who seems to have shared the hatred of Bestusheff and Murawiew, in common with the Imperial brothers and the most eminent of the Russian nobility. That this treasonable design was conceived in a purely selfish spirit, became abundantly manifest from the discordance

of views which prevailed amongst its originators; some of whom were for establishing a republic, others a limited monarchy, some a regency, and others again a middle system between a monarchy and a republic; whilst most were incapable of designating for what direct end they had conspired. Immediately previous to this explosion, Gen. Diebitsch had been dispatched to Warsaw to notify the demise of the late Sovereign to the Grand-Duke Constantine, he was accompanied by Prince Wolkonski, and returned in a short time with letters from the Cesarowitch, in which he declared himself ready to take the first oath of allegiance to his brother Nicholas, as Autocrat of all the Russias; thereby confirming the solemn renunciation which he had made on the 24th January 1822. By activity and dexterous management in this negotiation, no less than zeal and resolution in suppressing the spirit of turbulence which at that time manifested itself in the second corps, Diebitsch established himself firmly in the favour of the new Sovereign, was confirmed in the post of chief of the Imperial staff, and, in a general order of the day issued by Nicholas, was distinguished by as honourable a mention as was ever conferred by a Monarch on his subject.

“Among the services, which you have rendered to your country,” says the order, “posterity will justly account among the most important, the decision and energy with which you conducted yourself at a time when we were weighed down by the great calamity which had befallen the whole nation, and when you came forward *single-handed* to meet the approach of danger. In the name of the country at large, accept, through me, the tribute of our unmingled gratitude; and believe me to be,

“Your most affectionate,

“NICHOLAS.”

It was no trifling pledge of his Sovereign's esteem to be entrusted shortly after with the duty of receiving the remains of the late Emperor at Moscow, and conveying them to St. Petersburgh, where, upon the solemn obsequies which took place on the 26th of March 1826, he followed, at the head of the general staff, immediately next to his Grace of Wellington. And again, in the September of the succeeding year, he had the high gratification of being chosen as the medium through whom his Imperial Majesty extended a free pardon to those, who, by reason of their participation in the late conspiracy, had been condemned to hard labour, or exiled to the more distant provinces.

The connexion between Russia and Turkey had for years been gradually assuming a more unfriendly, if not a decidedly hostile character; the negotiations, which had long been pending between both powers, involved points, whence either of them could readily derive a plausible pretext for bringing that connexion to a precipitate termination; and it was unlikely that advantage would not be taken of them, whenever it might be convenient to Russia to give farther effect to her favourite yearning for aggrandizement in the South. On the 14th of April 1828, she therefore put forth a thundering manifesto of wrongs and outrages done to her by the Ottoman, and forthwith set her armies in motion. The indifferent result of the first campaign received, however, some compensation from the capture of Varna; and this was abundantly needed to revive the sinking spirits of the Muscovite soldiery, after their sanguinary miscarriage before Brailow, and the discomfiture of their attempts upon the entrenchments of Shumla. Diebitsch's friends have invariably repudiated the plan of this campaign, so far as he has been charged with having been its author; and this accusation bears its own refutation with it, if it be true, as it has been confidently alleged, that he had previously insisted upon the urgency of making Varna the basis of any aggression upon Turkey. The experience of preceding campaigns must, indeed, have convinced so wary a soldier as Diebitsch, that Shumla and the Balkan are nothing less than the Thermopylæ of the Turkish dominions on their northern side; and it is impossible but that he must have felt, with a brother soldier, that “after inspecting its natural and artificial strength, the visitor will acknowledge he could not have set foot

within it, save and except by the permission of its custodians.* At all events, the fall of Varna was the work of General Diebitsch, and virtually acknowledged as such by an eye-witness—his own Sovereign, in the Imperial rescript issued on the 12th of November, to which was added the grand-cross of the order of St. Andrew. His subsequent operations were confined to the establishing of the Russian forces, which continued under the chief command of Count Wittgenstein, in safe and comfortable winter quarters on the northern side of the Danube. Having effected this important object, and consulted with his brother-officers on the subject of the campaign for the following year, he followed the Emperor Nicholas to St. Petersburg; and, upon his return to Jassy, was appointed commander-in-chief with unlimited powers; an honour which he intimated to the army by his General-order of the 27th of February 1829, wherein a respectful and affectionate testimony is borne to the services of his predecessor. Between this time and the 20th of March, he was indefatigably occupied in the equipment, renovation, and reorganization of the Russian forces, and, in the same interval, had removed his head-quarters from Jassy to Isaaktsha. In the following month the campaign opened with desperate, though unavailing, sallies on the part of the Turkish garrisons in Widdin, Giurgewo, and Silistria, under the walls of which latter fortress their onset was so formidable as to impel him, though labouring under a severe fever, to animate his men to victory by his own presence, where the contest raged with greatest fury. May was signalized by an abortive assault upon the same stronghold; but, on the thirtieth of the month ensuing, the intrepid obstinacy of his opponents gave way, and the Russian eagle replaced the crescent within its frowning battlements.

This event left him with the unincumbered means of effecting an enterprise, which has deservedly placed him on a level with the first captains of the present day. He knew that the Grand Vizier, in command of "Shumla the inexpugnable," would concentrate his attention on the defence of that important stronghold, and foresaw, that if threatened in that quarter, he would leave every other point, especially that below Kamtshik, uncovered, rather than expose it even to the remotest prospect of danger. Diebitsch, therefore, moved up the main body of his forces in front of Shumla; then directed Gen. Rüdiger to advance to Kiuprikioi, on his right, and cover Roth's division on his left, which had orders to force the pass over the lower Kamtshik; both were to be supported by Count Pahlen with the reserve, and whilst this operation was proceeding, Gen. Krassowski, at the head of 40,000 infantry and cavalry, had it in charge to keep the Grand Vizier in check, and defend the line of operations until the passage of the Balkan had been effected. The circumstances, however, of this brilliant and successful achievement are of so recent a date, as to render it unnecessary for us to dwell upon its details. It will be sufficient to observe, that Diebitsch, having mastered every obstacle, and given a signal overthrow to the Grand Vizier, who had issued from his entrenchments with 40,000 Turks on the road to Paravadi, forced his way through the mountain-bulwarks of the Balkan, assaulted and carried Mesambri and Burgas, repulsed the gallant attack made upon him before Aidos by Ibrahim Pasha, and on the 31st of July, issued from that town a proclamation, which converted even Mussulman prejudice into respect and amity, by guaranteeing to all entire safety of persons and property: an act of grace unknown to the ferocious character of Mahomedan warfare. Eleven days after this, the victor's name was enrolled by his Imperial Master's hand in the annals of Russian glory, under the title of "*Iwan Iwanowitsh SABALKANSKY*," (the forcer of the Balkan,) in perpetual remembrance of his lofty enterprise and splendid triumphs.

The difficulties of the ground between Aidos and Adrianople would have

* Colonel Rottier's Itinerary from Tiflis to Constantinople.

required as many months, as it occupied him days to compass them, had he been called upon to encounter them in the presence of a less panic-struck antagonist. On the 19th of August, Eski-Sarai and the heights which command the ancient and splendid city of Adrianople, were in the possession of the victors. There were means of defence at hand; regular troops and militia to the extent of nearly 30,000, and approaches rendered tenable by deep ditches, numerous gardens, and close-set hedges; but a deputation of Turks presented themselves at the outposts to negotiate a capitulation, and Diebitsch required an unconditional surrender within the next fourteen hours. At five in the morning of the 20th, the columns of attack were on the march, and two hours before the expiration of the breathing-time allowed, the Russian commander was seen heading the right column within gun-shot of the walls. Another proposal for obtaining terms was summarily rejected—and the assailants were again in motion. At this sight, both soldier and citizen threw away their arms, and rushed out to welcome their invaders; whilst some of the Pashas advanced to offer greetings to Count Diebitsch, and others clapped spurs to their chargers that they might avoid taking a part in this scene of national humiliation. Fifty-six cannon, five-and-twenty standards, and five horse-tails, besides a rich booty in necessaries and munitions of war, fell a prize to the victors.

On the following day, Kirklissa, Lullé-Burgos, and Iniadi having been entered, the Russian advance was pushed as far as Tshatal-Burgos on the road to Siliyria. Thus established in the very heart of European Turkey, where could Diebitsch have been placed in a more auspicious position for exacting what has passed into the nomenclature of diplomacy—"indemnity for the past and security for the future?" The negotiations were opened by envoys dispatched from Constantinople; and, after they had spun them out until he threatened to break them off altogether, and dictate harder terms before the gates of Constantinople, a treaty of peace was ultimately signed at Adrianople on the 14th of September, and on the 23th of October following the ratifications by each Sovereign were exchanged on the same spot.

Of this treaty we have only space to remark, that, in proportion as it crippled the power and independence of the Ottoman empire, it extended the dominion and cemented the preponderance of Russia, to a degree, indeed, which has rendered her an object of new alarm and jealousy to every state in Europe.

Since the close of the Turkish campaign, Field-Marshal Diebitsch has been occupied in military avocations at St. Petersburg, with the exception of a few months in the autumn of last year, which he has chiefly spent on a visit to his patrimonial estates in Silesia. His health had been much impaired by the toils of war, and it was generally believed that this circumstance, combined with the undissembled jealousy he was exposed to endure from many of the native officers in the Russian service, had inspired him with a determination to retire from public life. But Poland has sounded the tocsin of independence, and he has been summoned to an inglorious task;—a task, in which whatever fame he may acquire, will be blotted out in abhorrence of the means through which he will have purchased it.

In personal appearance, Diebitsch is of diminutive stature; his complexion is sunburnt, and he walks with his head bent downwards; his eye is busy and full of fire; his forehead high; and there is something about his look which forbids familiarity. His person exhibits the vivacity of an active and stirring temperament, and his manners betray the man of the world and the warrior.

ON THE MODE OF ARMING AND FIGHTING
STEAM SHIPS OF WAR.

MR. BURKE says, that before a great change takes place, men's minds must be prepared for it ; and the maxim holds good in war, as well as in politics. Since the peace of 1815, the opinion seems to have been gradually gaining ground, that a considerable change must take place in naval warfare by the application of steam power. The French and Americans have accordingly been preparing for that event ; and the latter, it appears from the President's speech, have suspended the building of line-of-battle ships for the present ; Great Britain alone has been resting upon her arms ; it having been a maxim of a late Board of Admiralty, that she owes her naval superiority to the *yard-arm-and-yard-arm* system, and that she ought not to be the first to introduce any change.

Now this policy, I am inclined to think, will appear somewhat problematical to most people, who naturally imagine that statesmen, as well as soldiers, ought never to be taken by surprise, but to see their way clear before them. If a change is to take place when war arises, it naturally follows that large sums of the public money have been expended since the peace in objects worse than useless. Far be it from me to wish to detract from British courage in any way ; but at the same time I think it may be considered as a fundamental principle never to be lost sight of, that the nation which *excels in fire will be ultimately victorious in war*. And I am very much mistaken if war will not become a much more mechanical operation than it has hitherto been, in which although personal courage may still be very influential, yet, at the same time, its relative importance will be greatly diminished. In other words, it will be expedient to trust more to science, and less to physical force.

But to come to the matter more immediately at issue : *How are steamers to be equipped and fought ?* This becomes a question of some importance ; and under the existing circumstances, the Government can hardly be expected to be able to give an answer to it. Velocity and efficiency will evidently be the principal things to attend to ; and it is in the just combination of these two qualities that their advantages will probably be found to consist. If two steamers came to close action, broadside to broadside, there can be little doubt that they would immediately disable the paddles of each other, and that they would then become the most helpless of all vessels. If this reasoning be correct, it follows that close action must be evaded, and accuracy of fire will then become an object of paramount importance. By a parity of reasoning, I think it will follow, that *large* steamers, independent of their enormous expense, will be a positive incumbrance ; as at a long range, the advantage of fire is on the side of the smaller vessel, from having a much larger object to fire at.

Under these circumstances, the plan I beg leave to submit for the arming of steamers, will be with two short 24-pounders, working in grooves on either side of the foremast, parallel to the keel of the vessel, so as to throw either shot or shells. Similar grooves to be placed in the

stern of the ship, for the guns to be run aft if necessary. The vessel would thus be fought by the head and stern only. The laying of her guns would become a very simple operation, and might easily be done by a bombardier, from the opposite end to where they happened to be placed; while the gunners could give the elevation by quoins fitted for the different ranges. The bearing of the guns would, of course, be regulated by the helm, and the vessel would thus present the smallest possible front for an enemy to fire at. In addition to this, I would recommend that a gun-barrel be attached to the boiler, for the purpose of throwing musket-balls on Mr. Perkins's principle; for most of those who have witnessed that gentleman's experiments, will probably be satisfied that that invention will yet come into operation, whatever official reports may have stated to the contrary. It will at once be perceived, that the efficiency of the proposed plan depends more upon an accurate than a heavy fire; and although I am aware how difficult it is to procure that at sea, from the roll of the vessel, yet I am by no means disposed to reckon it impracticable.

The Woolwich Committee has at last discovered that artillery may be fired by percussion, without which, I conceive, the object in view to be utterly hopeless. Perhaps that body may also in time find out that the best powder may be used at a cheaper rate, than what is now issued both to the army and navy, as half the quantity answers the purpose. Its other advantages are so apparent that it may be unnecessary here to enumerate them. It does not foul the gun half so much; it does not produce half the smoke in action, and it diminishes the recoil more than a half. Coarse powder burns so slowly that the shot is half-way down the bore before it is all ignited. Hence the use of *long* guns arises. Fine powder, on the contrary, ignites instantaneously, and we accordingly find that the barrels of fowling-pieces have been shortened, exactly in proportion as gunpowder has been improved; and it is upon this principle that I have recommended *short* guns instead of *long* ones, as being much easier worked, and much more handy in every respect. I have to apologise for stating this to any one acquainted with the first principles of gunnery: but it is by overlooking it, that the decks of our men-of-war are lumbered with many hundred tons of useless metal, and the tumbrils of our artillery with double the weight of powder that is necessary.

The French, it appears, have fitted up some of their steamers with Paixhan's guns, ten and twelve inches in the bore. We also are getting some of tolerable dimensions. There is one now at Woolwich, a *cousin-german* to the great Turkish gun which was fired at the siege of Constantinople in 1453. Its bore is *amazing*. Its weight is 90 cwt. besides the carriage, and that of its shell 112 lbs. When once we see this instrument in full operation on board of a steamer, we shall be able to determine whether it is likely to prove more formidable to friends or foes. In the mean time prudence bids us to suspend our judgment.

BEN BOBSTAY.

CIGAR-SMOKING.

THE Surgeon-General of the Forces has recently made public his belief, that never, till within the last twenty years, did he see so many young men with pale faces and emaciated figures, and he attributes the existence of the evil to the use of Cigars. The unreflecting servility with which men adopt new and foreign practices, is fully exemplified in the present case; for it is notorious that the practice of cigar-smoking, the modern foppery from Regent-street to Cheapside and Cornhill, was an importation of the Peninsular War;—the imitation having been begun by the Spaniards, whose models are what are usually called the *savages* of America. The dietetic mischief, and consequent paleness of complexion and emaciation of muscle, which are attributable to the use of cigars, belong, no doubt, to an injury inflicted, perhaps, in more ways than one upon the aids and organs of digestion; nor is that hypothesis at all inconsistent with what we hear from so many cigar-smokers, namely, that their cigar is their dependence for digestion! That, after having impaired the organ, or weakened its tone, or dried up the salival menstruum, they should need a stimulant, even in the very form of the bane which injures them, is only of a piece with all that has been said of drinking, and especially of dram-drinking, with which latter debauch, the debauch of cigar-smoking has the closest possible alliance. We never pass one of those stifling rendezvous in the metropolis—a cigar-shop, open till the latest hours—without mentally classing it with the gin-shops, its only compeers!

Exclusive of the low habit of imitation, a dullness and feebleness of understanding, an absence of intellectual resources, a vacuity of thought, is the great inducement to the use of this, as of all other drugs, whether from the cigar-shop, or the snuff-shop, or the gin-shop, or the wine-cellar; a truth by no means the less certain, because it happens that men of the highest powers of mind are drawn into the vice, and made to reduce themselves, by their adoption and dependence upon it, to the lowest level of the vulgar; but, at the same time, it is not to be denied, that a great support in defence of cigar-smoking is found in the medical opinions sometimes advanced as to its salutary influence. Now, if we admit, broadly and at once, that there may be times and circumstances in which the inhaling the hot smoke of a powerful narcotic drug is useful to the human body, must it follow that the habitual resort to such a practice, and this under all circumstances, is useful also, and even free from the most serious inconveniences?

It is the admitted maxim, that if smoking is accompanied by spitting, injury results to the smoker; and the reason assigned is, that the salival fluid, which should assist digestion, is in this manner dissipated, and taken from its office. But may not the habitual application of the narcotic influence to the nervous system have its evils also? May it not weaken or deaden the nervous and muscular action which is needful to digestion? And may not even the excessive quantity of the matter of heat, thus artificially conveyed into the body, tend to a desiccation of the system, as injurious under general circumstances, as it may be beneficial under particular ones?

Smoking invites thirst ; and there is little risk in advancing, that whatever superinduces an unnatural indulgence in the use of liquids is itself, and without farther question, injurious, even if the liquids resorted to are of the most innocent description ; but, in point of fact, the cigar-smoker will usually appease his thirst by means of liquors in themselves his enemies !

It is said, however, that the use of cigars is beneficial when we find ourselves in marshy situations, with a high temperature, and generally, whenever the atmosphere inclines to the introduction of putridity and fever into the system. We believe this ; and perhaps a useful theory of the alternate benefit and mischief of cigar-smoking may be offered upon the basis of that proposition. When and wherever the body requires to be *dried*, cigar-smoking may be salutary ; and when and wherever that *drying*, or desiccation, is injurious, then and there cigar-smoking may be to be shunned. We know that, while surrounded by an atmosphere overcharged, or even only saturated with moisture, moist bodies remain moist, or do not part with that excess of moisture from which a drier atmosphere would relieve them ; and that living bodies, so circumstanced, are threatened with typhus and typhoid fever. It is highly probable, therefore, that narcotics, in such cases, may allay a morbid irritability of the nerves, or effect a salutary diminution of healthful sensibility ; under such circumstances, the desiccating and sedative effects of tobacco-smoking may prove beneficial ; while, in all ordinary states of the system and of the atmosphere, the same desiccative and sedative influences may produce immediate evil consequences, more or less readily perceptible, and undermine, however gradually, the strength of the constitution.

E. A. K.

NAVAL REMINISCENCES.

NO. VIII.

DINING OUT—AN ADVENTURE IN PORTUGAL.

AT the close of 1810, I was a youngster in an 80-gun ship lying in the Tagus, one of the squadron which formed a retreating point for Lord Wellington, in case of need. Our boats, with those belonging to the rest of the ships, some of them carrying guns, were detached up the river to aid the operations of the army, then, I believe, near Torres Vedras. They were occasionally employed in transporting, foraging, and skirmishing parties, and frequently conveyed large bodies of troops ; at other times, they were firing upon and clearing French redoubts, or conveying dispatches, or sick and wounded men down to Lisbon. Near both armies, we had a full view of what was going on, though we generally kept at a respectful distance from the enemy ; except when ordered to make a dash, at which times we were occasionally saluted with a dropping fire of musketry. However, a perfectly good understanding was kept up between the enemy's picquets and ourselves, and although a large squadron of English boats, a single French sentry would come down and drink, or offer his canteen with

the most perfect confidence, close to the water side. We had often immense labour in pulling up against the stream, and at times carrying or dragging our boats, which, from our ignorance of the river, were constantly grounding over sand-banks and shoals, half-a-mile long, and scarcely was one of these obstacles overcome, when another of the same kind presented itself; the current all the time running like a sluice.

It sometimes occurred that we lay idle for days together, and during one of these cessations from work, Lieut. E——, who commanded our division of boats, received an invitation from an English general officer, to dine with him in his tent. Away went the gay Lieutenant, a very fine young man, though somewhat, perhaps, too much of the beau. At this time the full dress of the navy, unlike the present commodious and really serviceable uniform, was the absurd attire of tight white breeches and silk stockings, a fine open waistcoat, showing a yard of frill, with a neckcloth that took a particular man at least ten minutes to tie. Then there were brooches and buckles of all kinds, and I know not what other follies. Well, imagine Lieut. E—— in full dress, having escaped from his boat with, perhaps, only one leg of his white pipe-clayed breeches dirtied by a muddy grapnel-rope, and not more than one of his silk stockings torn by the ragged tin on the blade of an oar; or let him, an active fellow as he was, have sprung clear out of the boat, in perfect order, and fit for the Queen's drawing-room. This, one would think, was but a bad dress for climbing trees; however, Lieut. E—— having to walk some short distance before he could reach the English lines, felt thirsty, and seeing a most inviting fig-tree near, he ascended it, and regaled himself, till a thought probably crossed him that he was spoiling his appetite for the general's dinner; one, alas, that he was not destined to eat, for as he looked down from "his pride of place," he espied the glitter of arms, and beheld the tree surrounded by a French picquet, who were much amused at finding an officer so situated, *en grande tenue*, or as we might term it, *in full fig*. They invited him to join their party, and carried him to the commanding officer on duty. He was then taken before Massena, and he confessed having felt some apprehension of being shot as a spy; but the farce, so near becoming a tragedy, ended fortunately for him, in a much more agreeable manner. He was put on his parole, and handsomely entertained by the French Marshal for several days. Furnished by him with horses and servants, supplied from his wardrobe, and commended to the care of a staff-officer, he was allowed to ride over all parts of the camp, and even to visit the adjacent country. At the expiration of a week he was dismissed, on giving his parole that he would not serve until duly exchanged, which did not happen for a month. In the mean time he remained on board the T——t, but did no duty, and was fortunate enough to escape all inquiry as to the cause of his absence by the Admiral.

REVIEWS AND CRITICAL NOTICES.

ON THE CONSTITUTION AND PRACTICE OF COURTS-MARTIAL.*

MANY causes have contributed to leave that portion of the public body, more immediately interested in this subject, destitute of adequate information upon the laws by which their discipline is upheld. The habits of the lawyer and those of the military officer have (as our author justly remarks in his preface) each their drawback, disqualifying, to a certain extent, either the one or the other, from producing that perfect treatise on military law, which might be expected only in the supposed case of engrafting upon a soldier of observation and experience the knowledge possessed by a good legal practitioner. Meanwhile, as this combination of character is not to be looked for, the thinking part of the army have had to drudge on with the aid of the now obsolete treatise of Tytler, and the work (in some respects more useful on account of its official information) of M'Arthur. Of late years, indeed, several attempts have been made to supply the defect complained of; we have a collection of adjudged cases published by Major James; a cumbersome volume by Mr. Samuel (rather on *martial* than on *military* law;) and the treatise,—good so far as its object extends,—of Major Kennedy of the Company's service; but to say of these that they have failed in conveying either in nature or extent the information required on the subject of courts-martial, is in no way to detract from the merits of the several authors by whom they have been compiled.

The work now before us is intended to supply what has been so long wanting, viz. *practical* and *tangible* information, by which the young officer may be instructed, and those older in the service may be assisted, in forming their judgment on particular points. It is a gratifying duty to direct attention to any work having a tendency to advance the character of the profession; and this must be the effect of promoting the study of those laws and practices by which the discipline of the army is to be maintained. We, therefore, notice, though for the present hastily, the work of Capt. Simmons with much pleasure. It forms an octavo volume of nearly 500 pages, replete with useful matter, divided into thirteen chapters, to which is added an appendix, containing official documents and forms of warrants, some of which were never before brought under the public eye. Its leading divisions, as the title-page indicates, are *the practice of courts-martial*, *the law of evidence*, which obtains or *should* obtain in such courts, and some notices on a branch of this subject little understood, we mean the *102nd Article of War*, by which *courts-martial* are, in certain cases, bound to administer justice *abroad*, according to the *criminal* code in force in *this country*. The difficulties with which a writer on this subject has to contend are many. The frequent alteration of the Mutiny Act and Articles of War is, in itself, a great discouragement to a commentator who would hazard observations on the intent of the legislature, or the meaning affixed by His Majesty to the articles framed pursuant to the legislative act. Our author has, however, we feel bound to say, argued many obscure points in a calm, accurate, and perspicuous form, and many of his hints deserve to be acted on in future provisions made for the regulation of the army. The most useful part of the work is, we think, found in that relating to *evidence*, and in the cases continually brought forward, in which, upon the approval or revision of courts-martial, strong opinions have been expressed by the superior authorities. These are, indeed, to be found in the general orders, but are only met with casually; it is, therefore, fortunate that a military man has been found, who, in his leisure hours, has been induced to condense, for the information of others, that which, from his compass of mind, education, and habits of reflection, he was well qualified to explain and illustrate; whilst his reading,

* Remarks on the Constitution and Practice of Courts-Martial, with a Summary of the Law of Evidence, as connected with such Courts; also, some Notice of the Criminal Law of England, with reference to the 102nd Article of War. By Thomas Frederick Simmons, Esq. Captain, Royal Artillery. Egerton, Whitehall, 8vo. 1830.

and the experience which he evidently possesses, have enabled him to bring forward much which is entirely new. We shall recur to this volume and the subject in general as one of the highest importance.

BOURIENNE'S LIFE OF NAPOLEON.*

IN the by-gone times of Humphry Ravelin, economy was wont to revel at the mess, and be quite at home over black tea and dry toast at a sub's breakfast-table, but in these "piping times of Peace," forsooth, she seems to have deserted the cloth, and flown for refuge to the "Libraries." We have before us an illustration. Three volumes, each consisting of between four and five hundred well-printed and closely-packed pages, substantially put together, and seventeen graphic embellishments, all creditably executed, particularly the three portraits of the Emperor and his two Empresses, for the inconsiderable amount of — as we were about to proceed, a friendly whisper in our ear, not unlike that of the Chief Baron of the Exchequer, recommended us to refer this point to the Publishers, or to our own advertising columns. Suffice it, therefore, that we have often sacrificed more at one night's sitting than has here afforded us some nights' entertainment, much food for reflection, and no inconsiderable quantity of new information.

The biography of men who have played prominent parts on the stage of life, whether for good or for evil, teaches useful lessons, nor is it to be wondered at, in this book-reading age, that one who may be said to have wielded the sceptres of many nations should have many biographers, or that each should have drawn a different picture, according to his own political bias. It is for posterity alone to determine.

To perform the duties of a faithful chronicler, requires far more than an honest intention; an intimate acquaintance with the tone of mind, private habits, and natural disposition, are also essentially requisite, and with these Bourienne, it must be admitted, had superior opportunities of acquainting himself, as he tells us in his preface—"My long intimate connexion with Buonaparte from boyhood, my particular relations with him when General-Consul and Emperor, enabled me to see and appreciate all that was projected, and all that was done, during that considerable and momentous period of time." To obtain credence for the other quality, he says in his introduction—"I am confident that all I state is true. I have no interest in deceiving, no disgrace to fear, no reward to expect. I neither wish to obscure nor embellish his glory. However great Napoleon may have been, was he not also liable to pay his tribute to the weakness of human nature? I speak of Napoleon such as I have seen him, known him, frequently admired, and sometimes blamed him. I state what I saw, heard, wrote, and thought at the time, under each circumstance that occurred. I have not allowed myself to be carried away by the illusions of the imagination, nor to be influenced by friendship or hatred. I shall not insert a single reflection which did not occur to me at the very moment of the event which gave it birth."

In the execution of his task we find no good reason to impeach these declarations. Substantiating, as he has done, most of the principal features by authentic documents, Bourienne has painted his hero neither as a demi-god nor a monster.

This English translation, which has been very faithfully rendered, is still more valuable than the original work, as upon all points where any obliquity from other published recital occurs, the translator has given the several accounts; and thus, in the form of notes, we are presented with the statements obtained from Napoleon's own dictation at St. Helena, from the

* The National Library, Vols. VII. VIII. and IX. The Life of Napoleon Buonaparte, by M. de Bourienne, his Private Secretary, with Notes, now first added from the dictation of Napoleon, at St. Helena, from the Memoirs of the Duke of Rovigo, of Gen. Rapp, of Constant, and of numerous other authentic sources. Colburn and Bentley.

Memoirs of the Duke of Rovigo, of Gen. Rapp, of Constant, from the writings of the Marquis of Londonderry, &c.*

It is unnecessary to give an analysis of this biography, or to enter upon a comparison of the publication in its present form, with others; it has nothing to lose and much to gain from rivalry. These volumes are eminently calculated both to entertain and be consulted; for the latter purpose the comprehensive index at the termination of the third volume will prove of considerable use.

PLAN FOR THE EDUCATION OF THE SONS OF OFFICERS OF THE
ROYAL NAVY AND MARINES.

In a former number of this Journal, we inserted the Prospectus of a Project for the education, at a moderate expense and in a systematic manner, of the sons of Naval and Marine officers. We have now the pleasure to notice the matured plan which, ere the appearance of our present Number, will have been submitted to the approbation and adoption of a preliminary Meeting, presided over by Admiral Sir Joseph Yorke.

The motives and general principles of such an establishment have been already set forth in the Prospectus alluded to. Its details and organization are embodied in a Pamphlet now before us, proceeding from Commander Dixon, the author of the project, whose zeal and perseverance in so beneficial a cause, encouraged by the warm approval of many of the most distinguished officers of the Service, entitle him to the respect of his profession.

We have only to suggest that, as the plan in question is equally applicable to the Army, a combination of the Services for its conjoint prosecution, might be attended with most advantageous results to both.

We extract from Commander Dixon's Pamphlet the general rules proposed for the adoption of the Meeting, and shall be happy to record the inauguration of so useful an Institution.

"ABSTRACT OF THE PRINCIPAL RULES TO BE PROPOSED TO THE
GENERAL MEETING.

"That the King having been graciously pleased to signify his approval of the principle of this Institution, and that it was deserving of the encouragement it had experienced, his Majesty be most respectfully requested to take it under his Royal Patronage.

"That the Institution be designated the _____

"That its object be to afford to the Sons of Naval Officers, a sound elementary Education, at a moderate expense, combined with religious and moral Instruction, according to the principles of the Established Church; and to give to the parents of the children a salutary voice in the appointment of their teachers, and in the companions of their studies.

"That those pupils who are intended for the naval or sea service, shall receive an efficient nautical education.

"That the Masters shall receive liberal salaries; and in the selection of individuals to fill this highly responsible office, particular attention shall be paid to their love for teaching, as well as to the depth of their attainments.

"That a person be appointed under the name of "Superintendent of the House," who shall be a half-pay commissioned officer and a married man; to him shall be intrusted the entire management of the establishment out of school hours; he shall likewise keep the accounts, and in general do all the duties of a clerk;—and that the wife of the Superintendent shall undertake the duties of housekeeper.

"That if necessary, a naval Surgeon, with the use of a small dispensary, be attached to the Institution.

"That a drill Sergeant or Master of Gymnastics be attached to the Institution, for the purpose of accustoming the pupils to carry themselves erect, and to acquire ease of deportment.

"That no pupil be admitted at an earlier age than 10 years, nor after the age of fourteen years.

"That the Head Master, who shall be a Clergyman of the Church of England,

* We perceive that these notes are also inserted in the French Edition of this Work, in Five Volumes, just issued by the same Publishers.

and graduate of one of the three Universities, shall every Sunday perform morning and evening service, according to the rites of the Established Church, and read also a short form of morning and evening prayer daily.

"That a Public Examination of the pupils shall take place previous to the Mid-summer vacation, as to their intellectual and moral acquirements.

"That a Reward or Medal be conferred on those pupils who most distinguish themselves at these examinations.

"If required by the parents, children may remain at the Institution during the half-yearly vacation, at a proportionate increase of expense.

COMMITTEE.

"That this Institution be under the direction of a Committee of Management, elected annually by the members.

"That this Committee have the entire management of the affairs of the Institution, and nominate the Masters on testimonials, and after public advertisement.

"That from among those members who may reside near the school visitors be nominated, who shall have authority to inspect every department of the Institution, and to report its state to the Committee.

"That in order to place the salaries of the Officers and Masters of the School on as economical a scale as possible, they will be allowed the privilege of the gratuitous board and education of one or more of their children.

"That all Servants of the Institution be selected, when practicable, from the naval service; and that all fees be prohibited.

"That in the admission of pupils, preference shall be given to the sons of officers who may be made prisoners of war, or who may be slain or drowned, to whose comfort the attention of the Committee shall be especially directed.

"That admission be then given to the children of shareholders in rotation.

"THE BUILDING (capable of enlargement) is to afford accommodation for the lodging, education, and board of two hundred students, and to be erected on a site which will unite the advantages of a clear and healthy atmosphere, with facility of communication with the capital and principal sea-ports.

"That application be made to his Majesty's Government for a grant of any vacant ground that might appear adapted for the purpose.

"That the funds be raised by donations, annual subscriptions, and 400 shares of 25*l.* each, to be taken by naval officers, two hundred of which shares shall bear interest at 4 per cent. per annum; and the remaining two hundred shall entitle the holders to send one pupil to the school for each share so held by them.

"That the shares be transferable with the sanction of the Committee.

"That the annual charge for the board and education of each pupil, including every expense, as well as the cost of books, stationery, and washing, shall be 25*l.* subject to a reduction in proportion to the accumulation of funds arising from bequests, donations, or subscriptions.

"That when the annual charge for board and education shall have been reduced to *l.*, the surplus funds shall be appropriated to the redemption of the shares.

"That when such redemption shall have been accomplished, the annual surplus shall be appropriated to the support and enlargement of the orphan foundation.

"That the treasurer, trustees, and auditors, be appointed at the general meeting.

"That the treasurer be required to deposit in the Bank of England from time to time, such monies as shall come into his hands in his own name, and those of the trustees; and that he be empowered to draw checks on the same, such checks to be signed also by one or more of the trustees, and that he keep a regular account of the funds of the Institution.

"The work not to be commenced until the whole sum given or subscribed for amount to *l.*

"That all flag officers, generals of marines, subscribing one guinea annually; captains, colonels, and majors of marines, commanders, physicians, and secretaries to commanders-in-chief, subscribing half-a-guinea, and all other officers (wardroom), subscribing five shillings and upward, be members of the Institution, who shall have the privilege of voting at all general meetings; and that none but their children shall be eligible to the benefits of this Institution, or be placed on the list of candidates for election for the orphan foundation.

"That all subscribers, to the amount of half-a-guinea annually, shall be entitled to one vote at elections on the orphan foundation; and those subscribing one guinea, to two votes."

GENERAL CORRESPONDENCE.

TO THE EDITOR OF THE UNITED SERVICE JOURNAL.

Military Superannuation and Widows' Fund.

MR. EDITOR,—May I be permitted to bring under your notice the accompanying copy of a letter, dated so far back as the month of April last, addressed by me to a distinguished officer, then at the head of an important military department.

You will perceive that it suggests the idea of forming a fund for the benefit of the army, but more immediately for the benefit of the widows and orphans of military officers. I am in possession of the answer which I had the honour to receive from the officer already referred to; but, not having applied for permission to give it publicity, I do not feel myself at liberty to do so without his previous sanction. I may, however, add, without any breach of courtesy, that the answer conveys an entire approval of the principle and advantages of such establishment, if carried into effect.

The object is well worthy of the British army,—it is identified with its honour—it is associated with its best and noblest feelings. The subject, too, has acquired an intense and fearful interest, from the regulations, recently issued by the War Office, relative to the Half-Pay, and Widows' Pensions.

I cannot err in persuading myself that the suggestion will receive your best consideration. In your hands I place it, reiterating the hope that the army will see what honour and humanity demand.

I have the honour to be, Sir,

Your most obedient and humble servant,

A RETIRED OFFICER.

Chatham.

(Copy.)

SIR,—It has long been matter for deep reflection,—painful as it affects the objects,—painful as it affects the army,—that the widows and orphans of military officers should be cast entirely upon the bounty of the country, and that not one single source of relief to mitigate the sorrows of those who have the most sacred claims to our sympathy, can be spared by the army. Every reflecting mind must feel this; and the army, jealous of its honour, must be anxious to redeem itself from a reproach too justly attaching to it. While every profession,—the humble as well as the most liberal,—considers it a *sacred* obligation to provide, out of its own resources, for its widows and orphans, it is painful to think that the army stands unmoved, and forms almost the only exception. It were difficult to share in that feeling, which is content to leave the dearest and most valued ties as a legacy upon the justice and gratitude of the nation. The country does its duty to the army,—let the army do its duty to itself.

Those must, indeed, be little taught by passing events, who do not foresee that we are verging towards that point when the reduced officer will be thrown upon his own resources, and the widow and orphan shielded only by the united sympathies of the army. The Government, it is not questioned, seriously contemplate the regulation, by which no reduced officer, under a certain proscribed length of service, shall be allowed half-pay, and no widow or orphan entitled to a pension, whose husband or father, unless killed in battle, had not served for a stated period of years. The imperative wants of a country may, perhaps, force such a measure upon its Government; but few minds will contemplate, without painful and mingled feelings the individual suffering, and even *misery*, which such a regulation is but too well calculated to spread throughout the service. To avert such a state of things, I would appeal to the best feelings of the army,—I would awaken it to a sense of what it owes to itself—to its own honour; I would make the army worthy of the country—I would also make it no less worthy of itself.

Influenced by these considerations, I am induced to propose that a Military Fund be established, to be founded and supported by the army itself. The fund to be called "The Military Superannuation and Widows' Fund," and having the following objects in view:—

1st.—To grant annuities to the widows of officers. The claimants under this head to consist of two classes—1st. Widows having no pensions from the country; 2nd. Widows having pensions.

2nd.—To grant allowances, in the shape of yearly income, to reduced and retired officers. The claimants under this head to consist of three classes. 1st. Officers reduced, having no half-pay. 2nd. Officers placed on half-pay by reduction, or from loss of health contracted in the service. 3rd. Officers retired on full pay, from length of service, or from total loss of health contracted in the service.

3rd.—To grant pensions to the orphan daughters of officers, and to found a military orphan school for boys.

I would make the provision for the widow and orphan form the first and primary object of the fund; the other objects to be carried into effect as soon as the capital of the fund, and the monthly subscriptions, shall authorize the appropriation.

To the principle of the measure every heart must accede: it is founded in the best feelings of the human heart, and claims the support and protection of all those who feel for suffering humanity, and who wish to alleviate the anguish and distress of their less fortunate companions. It would be a monument to the honour of the British army, as imperishable as its laurels; nor can any moment be more propitious than a moment of profound peace.

The principle, as far as regards the Widows' Pension, has been adopted by the Medical department of the army, and also, on a limited scale, by the officers of the Navy, under the express sanction of H. R. H. the Duke of Clarence, who felt all its inestimable advantages to that branch of the service; and the munificent provision which the Indian army makes for its companions in arms, and for its widows and orphans, will only serve as a noble example for our own army.

If it is practicable then for detached branches of the service, it is practicable for the whole; and few will think, in the face of some recent establishments,—good in themselves, but certainly of minor and subordinate intent,—that the army does not possess, *within itself*, abundant resources for founding and supporting a *Permanent* Military Fund.

My profession excludes the expectation that I should be qualified to enter into all the niceties of arithmetical calculations connected with the plan: this part of the duty essentially belongs to the professional accountant or actuary; and I am persuaded the able actuary employed by the Government would willingly give his aid in making the necessary calculations and tables. It appears to me that the Table of Rates and Subscription, the mode of Management, and the Rules and Regulations of the Bengal Military Fund, might be adopted with great advantage, subject, of course, to such modifications as the difference between the two services might render necessary, in the opinion of a special board of officers, to whom, under the sanction and authority of the General Commanding in Chief, the details of the plan would be referred.

Such is the plan which, with all its imperfections, I take the liberty of submitting to your deliberate consideration. I address myself to you, on this occasion, less from regard for the high official situation which you hold at head-quarters, than for the enlarged and benevolent feelings which attract your mind to all and every thing which can promote the honour and interest of His Majesty's service.

The present feelings of the country, naturally anxious for every possible reduction of its expenditure, and the policy of a just and humane Government, (I speak of no particular ministry,) must be interested in giving

effect to a measure which, by its operation, may ultimately render a diminution of what is called the *Dead Weight* less impracticable, and, I fear not to add, less incompatible with what the Nation and the Government owe to the army. I know the fact, that the Government contributes 10 per cent. out of the revenue of the Island of Ceylon, yearly, towards the Civil Superannuation Fund of that colony; and I am yet to learn that the services of the army give it a less claim to an equally liberal and grateful consideration.

Can I hope that the object I have in view will plead my apology for breaking in upon your time at so great a length? When you are freed from the pressure of official duties, you will, perhaps, not be unwilling to devote your attention to its consideration; and I shall feel honoured by the expression of your opinion, and your views and sentiments.

I have the honour to be,

Yours, &c. &c. &c.

Chatham, April 20, 1830.

* * * Objections to such a provision as the foregoing might certainly be stated; but they are not of weight to counteract the beneficial principle of a plan which we recommend to general consideration.—Ed.

J. M. on Duelling, in reply to his Critics.

MR. EDITOR.—WILL you permit me to say a few words in reply to your Correspondent A. B. who, in the last number of the Journal, charges me with “a marvellous confusion of ideas,” for having asserted, whilst attempting to lay down some rules on the subject of Duelling, that a second in a duel “is answerable to God and his country for any loss of life that by temperate, judicious, and conciliatory conduct might have been avoided;” arguing that this is sanctioning a breach of the Commandments, at the same time that we are acknowledging our responsibility to God, &c. &c. Such sweeping charges are more easily made than proved.

As self-defence for the protection of property as well as life is allowed by Scripture* and the law of England, on what principle shall we be prevented from defending our honour and character, that must be dearer to us than life itself? If a man is permitted to defend a little paltry gold at the risk of slaying the aggressor, on what ground can he be prevented from defending the reputation of those whose fame must be dearer to him than his own? Still, men must be answerable to God for any blood so shed, “that, by temperate and judicious conduct, might have been avoided.” Dr. Johnson says, “I do not see that fighting is forbidden in Scripture; I see revenge forbidden, but not self-defence. A man *may shed the blood of a man who invades his character*, as he may shoot him who attempts to break into his house.”† Lord Kames, in the *Sketches of Man*, takes the same view of the subject;‡ so that I share the “marvellous confusion of ideas” attributed to me not only with the great moralist himself, but also with a great judge and historian—I am verily not ashamed of the fellowship.

In consequence of the fatal termination of many duels, owing to the very improper manner in which they had been conducted, (I referred to an instance in which life had actually been tossed up for, and might have added the case of Philips and many others,) I thought it right, whilst writing on the subject, to propose a few common-place rules in the avowed hope of averting similar misfortunes for the future, and also with a view of correcting a dangerous error, that a book, termed “The British Code of Duel,” had tended to promulgate. This Sir Lucius O’Trigger kind of pedantry would, perhaps, have exposed the writer to a little ridicule from those who know how peaceful and unwarlike are his own habits and pursuits, had not the object, in some measure, sanctified the motive; but I certainly never ex-

* Exodus, xxii. 2.

† Boswell’s Life of Johnson.

‡ *Sketches*, vol. i.

pected to have seen it made the subject of a grave charge; for surely no one will seriously maintain that gentlemen are likely to go out and fight merely in order to practise these rules; so that they can by no possibility do harm, but may perhaps, at a future time, do good. If a man cannot suppress an evil, is he, therefore, prevented from striving to alleviate its effects? Nor were they principally intended, as supposed by A. B. for the United Services: because, as far as my own observation goes, there is much less duelling in the Army and Navy than in civil life: a circumstance highly honourable to the services, as it shows that they are setting an example of that high and gentlemanlike conduct which should always form a distinguishing mark of the professions.

It was the object of the article that has led to this discussion, to *check*, as much as possible, the practice of duelling, by making seconds, on whom much depends, attentive to their duty and responsibility; by calling on society, so far at least to assert its own dignity, as not to allow the mere standing of a paltry shot to constitute a proof of gentlemanlike conduct and sentiment; and, above all, by divesting the duellist of any claim to courage which he could pretend to found even on the "fighting of fifty duels." Yet, in the face of this very sentence, and much more to the same purpose, your Correspondent A. B. goes over the ground I had taken, proves, in a very able manner, that a duellist is not to be considered a man of courage, never states that I had taken the same view of the case, but, as he has been attacking my opinions, leaves it to be inferred, as a matter of course, that I had attempted to "class the gallantry of the duellist with that of the soldier," though exactly the reverse happens to be the case.

I mention this without comment, for I cannot suspect of wilful misrepresentation a writer whose general sentiments entitle him to respect, and who almost begins his letter by a quotation from that book which is the source of pure and unsophisticated truth alone.

Another contributor, who, in the same Journal, signs himself C. D. says, "To the remark of J. M. that 'it is only by raising the standard of politeness and moral conduct, and insisting on its being acted up to by all parties, that the abolition of duelling can be effected;' it might be suggested that, to the standard to which he refers, it is the object of Christian education to raise us," &c. Yes, certainly, "to raise us;" but the question is how far has it raised us? Are there no coarse, envious, licentious, and bad-hearted men in the most polite society? Is *l'avarice, enfin, mère de tous les crimes*, already banished from the world? Do we not, on the contrary, behold the worship of Mammon openly carried on, from the splendid salons where the high and the noble may be seen bartering independence and parliamentary votes for places to themselves, and preferment for their sons, and fortune-hunting mothers parading their daughters for sale to the highest bidders, down to filthy scenes lately exhibited in the streets of Liverpool, where men brought that liberty to market which thousands are now yelling out for, many of them with no other view than to have more of the same commodity to dispose of? At every ordinary dinner-party you may easily tell the relative wealth and influence of the guests by the general respect shown to them, as well as by the smiles of the "courteous host" and hostess; but where is the distinguishing mark that society sets upon worth and virtue? A fifty-power reflecting lantern would hardly, in these days, enable Diogenes to discover an honest man, not so much for want of worth and honesty—for there is, after all, perhaps, more virtue in the world than the world gets credit for—but because vice is forward and presuming, and constantly throws virtue, which is humble and retiring, into the shade, and never scruples, in its greedy course of low ambition, to trample it down whenever it can be done with impunity. In such a state of society, which besides punishes the presumed absence of honour without rewarding the reality, reputation and character cannot possibly be left unguarded; for men of high and generous feelings have, after all, little left to lose in this world when they

have once lost even this world's esteem. And what protection is there in many cases but what is afforded by the precarious and uncertain law of battle: itself avowedly an evil, rendered necessary by the evil passions of the human breast, that too often leave us nothing but a choice of evils.

I here close the subject. I have proposed the best remedy in my power: it was not very well timed, I allow, for times of revolutionary tendency are not well adapted for the advancement of morality, but it leaves the field just as open as it was before, to the exertion of abler hands. As to your two correspondents, I can only add that the sentiments they express will ensure for them the respect of all well-thinking men, even of those who may lament that the honest views and wishes contained in the writings here replied to, cannot, in the present state of society, be carried into practical effect.

Without again alluding to the writers above spoken of, for it would not be applicable, I may mention, *en passant*, that to place any particular words or sentences of a modern essay in opposition to scriptural quotations, is not a fair way of judging of its merit; the entire must be looked at, as it is only by trying the object and tendency of the first by the spirit of the second, that justice can be done.

I am, Sir, your most obedient servant,

J. M.

* * * It was our intention to have offered a few observations upon this subject, so sensibly and temperately handled by our several contributors; but J. M., to whose opinions, and for the reasons he assigns above, we decidedly lean, has saved us the trouble. We claim, however, the merit of impartiality, in having fairly submitted both sides of the question to judgment.—Ed.

Captain Cook and Sir Joseph Banks.

MR. EDITOR,—I observe your correspondent D., in his "defence of Captain Cook," in your number for March last, is unacquainted with the true cause why Sir Joseph Banks did not accompany Captain Cook on his second voyage, which circumstance is readily accounted for, without reference to the unhandsome manner in which the great navigator is mentioned in the Report of the Geographical Society of Paris.

My information is derived from an individual who accompanied Cook in his first and second voyages, and was otherwise intimately acquainted with his character in all its bearings.

Sir Joseph Banks did fully intend to proceed on the second voyage—so much so, that all his preparations were completed, and every thing he considered essential for the voyage was actually on board the *Resolution*. At Captain Cook's particular desire, a poop-cabin was built on the *Resolution*, which he intended to occupy himself, giving up his proper cabin for the accommodation of Sir Joseph Banks, and the other scientific men who were to have accompanied him. On the passage down the river Thames to the *Nore*, the *Resolution* was discovered to be so very crank, that it was deemed expedient to take the poop off her, thus obliging Captain Cook to resume his proper cabin. Sir Joseph Banks, in consequence of this arrangement, finding himself deprived of the expected accommodation, finally determined on not proceeding; and this was the sole cause of Sir Joseph Banks not accompanying Captain Cook on his second voyage.

The *Forsters* did not join the *Resolution* till she had reached Plymouth Sound, and their accommodations were not so comfortable as would have been the case, had the poop remained on the ship—they were, however, the best that could be afforded, under the circumstances.—Their complaints against Captain Cook are principally in reference to the badness of their accommodation, and which it was out of his power to remedy.

With reference to the ravages of disease, said to have been inflicted on the

natives of the South Sea Islands by the crew of Captain Cook, there is now in the possession of one of the Commissioners of Greenwich Hospital, an original order from Cook on this subject, strictly prohibiting every person diseased, or suspected to be so, from leaving the ship on any pretence whatever, or having any communication with the natives. This, though inefficient, clearly proves his great anxiety to prevent the spread of that devastating malady among the natives. Can a similar order be produced from Bougainville, or any other of the French Navigators, who visited those Islands?

That his crew entertained a most affectionate regard for their commander may be gathered from the extreme anxiety they evinced at one period of their voyage, when he was seriously ill; their first and constant query at the relief of each watch was after the health of their beloved commander, whom they always considered as their father and their friend; and finally, at his lamented death, so enraged and infuriated were they at the loss of their revered chief, that it was with great difficulty they were restrained within the bounds of subordination, because they were restricted, very properly however, from proceeding on shore, and taking instant and ample revenge for their irreparable loss. I could add many anecdotes, from the very best authority, to prove his goodness of heart and benevolence of disposition; but as they were communicated in confidence, and without an idea of their being made public, and would moreover be displeasing to an amiable and venerable female closely connected with him, if seen by her, I will therefore abstain. Indeed, I consider his character established on so firm a basis, as to stand in no need of my weak vindication; and I trust that it will not be affected by the unjust and illiberal remarks contained in the Report of the Geographical Society of Paris.

I will, however, add to the character of our navigator, quoted from Captain King by your correspondent D. (and which, I think, conveys a just estimate of it in a few words,) one from the pen of Dr. Reinhold Forster, who certainly cannot be accused of partiality towards him. "If we consider his extreme abilities, both natural and acquired, the firmness and constancy of his mind, his truly paternal care for the crew entrusted to him, the amiable manner with which he knew how to gain the friendship of all the savage and uncultivated nations, and even his conduct towards his friends and acquaintance, we must acknowledge him to have been one of the greatest men of his age, and that reason justifies the tear which friendship pays to his memory.

I am, Sir, your obedient servant,

London, April 19, 1831.

Q.

Case of the Naval Architects.

MR. EDITOR,—I shall be obliged if you will allow me to call the attention of the public, through the medium of your pages, to an act of extreme injustice committed against a certain class of the public servants by the present Naval Administration,—I mean those called Naval Architects; a short account of the cause of whose institution, and present state, I gave in your number for February last.

Previous to Lord Melville's quitting the Admiralty, an order was issued to the several dock-yards, that all new appointments to situations below the rank of foremen of the yard, should be held by persons who were to receive day pay, leaving those, however, in the present possession of those situations, their yearly salary as heretofore: so far, right; any person receiving such an appointment knew under what circumstances it was to be held, and had the option of accepting or rejecting it. On the change in the Admiralty, this act, which was intended to be *prospective*, was made to include those who had for many years been in the receipt of an annual income, and was even extended to those students who had from their entrance into

the service been on salary, and which was an express condition of their entering it. In a copy of the regulations established relative to the admission of students into the School of Naval Architecture, now before me, the sixth article says, "they will be allowed the following *salaries* in *QUARTERLY* payments;" this refers to the seven years of study. The seventh article says, "On the expiration of their apprenticeship the students will be eligible to all situations in the ship-building department of his Majesty's service, and in the event of there being no vacancy in any of his Majesty's yards, they shall be employed as supernumeraries in the yards *until vacancies* do occur*, and be allowed the *yearly* salaries recommended in the third report of the Commissioners for revising the civil affairs of the Navy. The next and last regulation relates to a bond for 500*l.*, entered into by two sureties for each student, that he should not quit the service under a period of seventeen years, on pain of the forfeiture of the amount of this bond, in order that the expense of the education of those students might not be lost to the Government. Here then there is a mutual agreement between the two parties, and the willingness of one party to give up his part does not free him from his responsibility to fulfil the other; or in other words, the Admiralty, after cancelling this bond by which the students were tied to the service for a term of seventeen years, are not at liberty, in justice and equity, to shake off that tie by which they bound themselves to the students. Those regulations I speak of were formed by the King and Council, and upon the faith of them many persons entered the service, who never would have done so under the degrading terms now forced upon them. It may appear very fair to say, "If you are dissatisfied with the present conditions, we are willing to free you from your bond, and you may then apply for your dismissal, which will be granted to you,"—but after devoting nearly seventeen years of the best period of their lives (as some of those students who have not yet been appointed to situations have done), and having arrived at the age of thirty-three or thirty-four years, with families depending on them for support, to have to submit to any terms which the caprice of this or any other Board of Admiralty may dictate, or the alternative of seeking at that time of life new means of subsistence, is, to say the least of it, hard indeed. If the alteration of circumstances, since the formation of this establishment, has rendered the number of those admitted to it too great, and the Lords of the Admiralty are desirous of reducing the number of claimants for situations, a fair and honourable way is open to them to do so, by allowing those *supernumerary* students to retain their present incomes (which are guaranteed to them by the regulations I have quoted above) and endeavour to provide for themselves in private employment, under this condition, that if, when called on to accept of appointments in the dockyards, they are unwilling to do so, they shall forfeit all claim to a continuance of their salary. By this means there would be no increase to the public burthen, but a constant tendency to its diminution. If it be lawful for one party to reverse the acts of their predecessors in office, and the Lords of the Admiralty thus to cancel the decisions of the King and Council, who will place reliance in public faith? who will enter that service, where, after having faithfully discharged his duty until old age approaches, he may be displaced without any cause assigned but the will of those who have the *power* to act unjustly? I would not wish it to be understood that I think the present Admiralty mean to go to this extent, but every measure which tends, however remotely, to such an end, should be viewed with the greatest jealousy, and checked before it attains to too great a head.

I am Sir, your obedient servant,
PHILO-NAUTICUS.

April 19, 1831.

* Even the filling these vacancies by persons not educated at the school, is therefore a breach of their agreement.

Yeomanry Cavalry.

MR. EDITOR,—Since you condescend to notice a branch of military service so bumble as the Yeomanry Cavalry, I request the attention of those among your readers, whom such subjects concern, to a few remarks upon one or two points which you have not touched; at the same time tendering you my warmest thanks for the excellent observations contained in your last Number.

It is generally reported that some instructions are being drawn up by authority for the movements of Yeomanry Cavalry; that these instructions will be different from the elucidation of Sir David Dundas's regulations; and that the practice recently adopted in the regular cavalry, will be enjoined in the yeomanry also. I do not presume to offer an opinion upon their propriety for regiments of the line; but having an experience of twenty years to enable me to form a judgment upon their advantage for regiments, or smaller corps of yeomanry, I venture to submit the reasons for considering them inapplicable to the latter service, in the hope that these observations may meet the eyes of those who have it in their power to give them effect if found to be valid.

The present practice of regular cavalry places the officers in line in front of the men. The officers have nothing to do but to dress themselves: they do not, and cannot dress the men who are in their rear: these must be dressed by the non-commissioned officers, or other flank men of the divisions into which each troop has been told off.

The objections to this for yeomanry are manifold. The horses of yeomanry officers are not so steady as the horses of officers in regular cavalry; from not being so well broke in the school, they seldom stand quiet, and consequently do not preserve a correct line. This is, however, of minor importance. A more serious objection is, that the officers are thereby not in a situation to direct their men. It is possible that the commissioned officers of the regular cavalry may not be more efficient than the serjeants and corporals; nay, it is possible, that the non-commissioned officers in regular regiments may be more steady, and *au fait*, at regimental movements than their superiors; but I am quite certain that such is not the case in yeomanry regiments; and that the commissioned officers take greater pains to acquire a knowledge of their duties, and are to all intents and purposes better soldiers, than their serjeants and corporals. In all movements from line into column, the correctness must depend upon the individuals on the flanks, both pivot and wheeling: and also the accuracy with which the proper wheeling distances are preserved between one division and another; and it is of great importance to have officers on these flanks, because they are the most intelligent men of the regiment; so that, if I were to suggest any alteration from Dundas, it should be to place the *serrefile* officers on flanks of all divisions in line, rather than in the rear. An officer, when abreast of his men, can preserve them in much better order than when in front of them. When a line is ordered to advance, some horses rush forward, and some hang back, so that for the first few paces the line is always irregular. An officer on a flank can easily and quickly correct this irregularity; but the men will not pay the same ready attention to a serjeant or corporal. It is useless to say that they ought to do so: we must make use of a force as it is, and as it can be used; and not attempt to make it according to an Utopian standard, that can never be attained. It is owing to this irregularity in starting, that a good yeomanry officer is cautious of executing his charges too quickly; and therefore he will not give the order to trot or gallop, until he sees the line perfect at the slower pace; and hence, however well drilled a regiment of yeomanry may be, its movements are always slower than those of a regiment of the line. The Yorkshire Hussars of Lord Grantham, and the Cheshire Yeomanry, which were as perfect as any regiments of the line, were nevertheless slower in their evolutions, owing to this cause.

Another objection to placing the officers in front is, that the line is thereby diminished. It is true that the diminution is very small; but since troops of yeomanry seldom muster for drills above half their strength of privates, after the novelty of the first year has subsided, even that small diminution is inconveniently felt, and no one advantage gained.

Every description of military force possesses advantages and disadvantages peculiar to itself. Heavy cavalry cannot perform all that light cavalry can, and *vice versa*, as Lord Anglesey learned to his cost at Waterloo. Each must be made perfect in its kind. If yeomanry are inferior to regulars in some things, there is the greater necessity for rendering them perfect, as far as it is possible, in other things. One of the good ingredients in yeomanry, is the intelligence from superior education in the men; one of the bad ingredients is want of smartness and attention in small points of discipline. The great object to be obtained by a commander is precision; quickness comes next; and though rapidity is valuable, it is inferior to correctness. No word of command ought ever to be given to a yeoman, without his being made thoroughly acquainted with the object which the commander wishes to attain by it. It is of comparatively little importance whether the commanding officer utters one, or twenty syllables: the only point worth considering is, by which means he gets his commands most efficiently executed. In the new regulations, the words of command are much abbreviated; but I am perfectly certain, that those yeomanry corps which shall adopt them, will not be so correct in the field as those which adhere to the apparently longer, but really more rapid orders of Dundas.

I am, Sir, your obedient servant,

A FIELD OFFICER OF YEOMANRY.

April 18th, 1831

* * We are not aware of any forthcoming instructions such as those alluded to by our Correspondent; indeed, till the revised movements for the cavalry shall have been *officially* adopted, no corresponding rules can be issued by authority for the guidance of the yeomanry. Meanwhile, the observations offered in our last Number, will, we think, be found sufficient for all general purposes.—ED.

State of the British Artillery.

MR. EDITOR,—I have perused with considerable interest and attention, the able article under the signature of "Mentor," in your last Number, "On the Organization of the British Artillery," and I rejoice that the subject is taken up by so zealous and judicious a correspondent. I entirely concur with him in lamenting the present deplorable state of the British Artillery, and, let me add, Engineers' department. Though myself in a different branch of the service, yet as a British officer, and from having served much in conjunction with artillery, I feel very forcibly the absolute and immediate necessity of some change being effected respecting artillery promotion, and I feel as forcibly the absolute necessity of putting this "right arm of war" of one service on a footing to meet the battle-storm, whose dusky clouds are now gathering fast over the horizon of Europe. *The present inefficiency of this service is most glaring, both in number of men and practice.* I am the more led to offer these remarks from having been a late witness to the excellent and "*workmanlike state*" of the artillery of France. I allude especially to the force in that branch that I saw embark at Toulon for the African expedition, and which force alone comprised very nearly *as many men and guns as England can now call effective in the same branch!* No officer in the service is a better judge than the gallant and distinguished officer now at the head of the ordnance, of the vital importance of this peculiar arm of the service; he well remembers the cheers of his gallant brigade, at the splendid manner in which the guns attached to it

were served at Waterloo; he well remembers the dying testimony of the glorious Picton, (to the command of whose division, he, Sir James, succeeded) as to good service done by those guns; and he will doubtless put the ordnance department in such a state, that it may in future days again draw forth such words as these from a defeated enemy: "The Imperial Guard made several charges, but was constantly repulsed, crushed by a terrible artillery, that each minute seemed to multiply. These *invincible* grenadiers beheld the grape-shot *make day* through their ranks."*

I have the honour to be, Sir, yours, &c. &c.

Dux.

Medical Department.

MR. EDITOR.—The last number of the United Service Journal contains a letter from an old medical officer, (Medicus Senex,) with a schedule of pay and allowances, &c. as laid down, he says, by H. M. Warrant, May 22, 1804.

With the observations contained in that letter I fully coincide, and hold nothing to be better established in law and in equity, than the right of the medical officers of the Army to all the advantages hitherto enjoyed under that warrant. Of course I mean all officers in the service previously to July 1830; all who have entered, or who may enter subsequently to that period, must claim under the late warrants. Should any officer, however, of the former class, accept of any advantage whatsoever under the late warrants, he must be considered as thereby relinquishing all right to claim at any future period under the warrant of 1804.

It is a painful thing to find that any doubts or difficulties should have been started on these subjects, and that persons in subordinate situations should have been compelled to struggle individually, each in defence or vindication of his own just claims. But so it is, unfortunately, in our department, between the head of which and the members no common feeling of confidence or cordiality seems to exist,—no *sympathy*, as we say.

My object, however, at present, is not to discuss these matters, but to warn your readers not to place implicit reliance on the schedule given in the last Number, as some of the rates therein specified are subject to *deductions*, of which no notice is taken by your Correspondent.

The gross full-pay of Regimental Surgeons also is overstated, the true rate under the warrant being 12*s.* and not 12*s.* 6*d.*

Should any of your Correspondents have in their possession copies of the schedule of 1814, or of any circular or general order connected with it, or with the present subject generally, it would be an act of kindness and justice to the profession to give them publicity through your pages.

April 10, 1831.

MEDICUS.

A Grievance of Mates in the Navy.

MR. EDITOR.—The warranted class of Mates in the Navy have but of late years sprung up, and I make no doubt the undermentioned grievance must have been entirely overlooked, or certainly it could not have remained so long unheeded.

It is that second masters take precedence to mates; on what principle, I am at a loss to comprehend; but it is a circumstance that creates much ill-will between the two ranks, more particularly in vessels commanded by lieutenants, where mates are placed so frequently under the orders of the second master. The midshipman, previous to passing, is senior to the master's assistant, although but two years in the service. On his undergoing the examination to qualify him for a lieutenant, he takes the name of

* Vide "Relation fidèle et détaillée de la dernière campagne de Buonaparte, par un témoin oculaire." Paris, 1815.

mate, and, if by good fortune he obtains his commission, he takes rank over both the second master and master.

The examinations midshipmen now undergo both at the Naval College and before three captains, with the experience they obtain, fit them more particularly for the situation of Commanding Officer: while many from the merchants' service, undergoing an examination for a second master, are at once appointed to that rank. Fancy, then, a mate of ten years passed so situated, how can he perform his duty with the least zeal or pleasure under the orders of one so new to the profession, and possessing so little knowledge of the service? It is a grievance, if once remedied, would call forth the thanks of a large proportion of young officers, and ultimately prove of real benefit to the profession.

G. G.

"Radical" and the Foot Guards.

MR. EDITOR,—I am induced to direct your attention to a letter in the Times newspaper of the 18th instant, signed "Radical," in which, after much profession of being a "brave man," the writer, who I hear is a Mr. Jones, states that he was driven from the profession, in which thirty years of his life had been passed, and, as he hopes, without a stain, in consequence of an order he had given for the maintenance of discipline, which order the Duke of York directed to be torn from the orderly-book in the presence of his own officers and the field officers of the garrison of Dublin.

Proud testimonial to the memory of the illustrious Duke!—I have never yet been so fortunate as to meet with a Radical who was not a tyrant; and I therefore consider this act of his Royal Highness to be in accordance with all his other proceedings, in support of the rights of the soldier and of humanity, and which line of conduct so justly entitled him to the appellation of the "Soldier's Friend."

But frail mortals are liable to err—"facts are stubborn things," and "Radical" promises to convince the public that he was right and the Duke wrong. Of Mr. Jones's services I do not pretend to know any thing except from his own trumpeting: there are men of his name who reflect honour on the military profession, from whom our hero must be distinguished in future story, as "Radical Jones," or "Orderly Book Jones," and thus, at least, enjoy an inglorious immortality apart from his laurelled fellows. The Jones, in the shyness of his modest nature, promises in his said letter, that "at some future and befitting period" the Order shall be given to the public. Surely this "honourable man" cannot consider any time so befitting as the present; for Caesar, or somebody else, says "he is ambitious"—let him now prove to the world, and especially to that portion of it classed as "worthy and independent electors," his own "purity" as a soldier when in command, and then his attacks upon all persons and characters will have greater weight: the publication of this testimonial of "discipline" and humanity would ensure him respect or contempt.

I am sure, Sir, you will not hesitate to do justice to Mr. Jones by inserting the Order, if he sends it to you. Your pages are required, I admit, for valuable information, but recollect this Order has been torn from the Orderly Book of the Guards; and, therefore, it is *something* to put on record, and it is something that will do justice to the military career of so renowned a "Radical and Emancipator."

I have already observed, that of the services of this said Mr. Jones I know nothing, but I hear that he was at Bergen-op-Zoom, which brings to my recollection an anecdote I have heard connected with that unfortunate affair. At Bergen-op-Zoom an officer had to deliver a message to the enemy. Meeting with a French grenadier, he attempted to communicate his instructions, but not being understood, the grenadier took him by the shoulder, and, with a contemptuous—*allez foutez*,

"Poured his foot in thunder on his rear"

and thus sent him forward on his errand.

ANTI-RADICAL.

* * * While the individual who is understood to scribble under the signature of "Radical," confined himself to the usual topics of pot-house declamation, his grotesque exhibitions concerned us not; but that ex-officer having thought proper, with edifying simplicity, to reveal the cause of his own degradation, and, thereupon, to assail the memory of a Prince, who, by common consent of officer and soldier, was regarded as the truest friend of both, and is revered as such in his premature grave, we shall feel it to be our duty to expose the exact pretensions of his slanderer. Ed.

Contagion and Malaria in cases of Fever.

MR. EDITOR,—I have this moment read the very interesting article respecting the Gibraltar Epidemic contained in your Number for February. I had never previously read one line relative to the point at issue between the contagionists and the non-contagionists, nor do I know aught of Dr. Smith, or of his pamphlet. I am not a medical person, but a humble Commander in the Royal Navy, and consequently have no other view than a desire to assist in the investigation of *truth*, by stating some circumstances which have occurred under my own experience, materially tending to confirm the hypothesis of *malaria*, and not *contagion*, being the cause of infection in cases of the West India yellow, or black vomit fever. The instances I shall adduce may be readily authenticated by documents registered at the Admiralty Office; therefore, perhaps, I may be excused for not signing my name to this communication, particularly as I might by so doing incur the risk of giving offence to Dr. Pym, with whom I am slightly acquainted, and for whose character I entertain the highest respect.

In the year 1804 or 1805, His Majesty's sloop-of-war the Kingfisher entered Demerara river on the coast of Guiana, with scarcely a sick person on board, and certainly without any case of fever. The vessel had not been long, however, at this anchorage before numbers fell ill, and the man began to die rapidly,—most of them exhibiting the black vomit symptom. We sailed almost immediately, and although most of those on the sick-list perished,—including the Commander, Capt. Cribb, the Carpenter, Mr. Sutherland, and a great number of the ship's company,—yet the disease was instantly checked by leaving Demerara, and no fresh case occurred after we got fairly out to sea.

Now, if this black vomit fever had been propagated by *contagion* alone, why should it not have gone on spreading as rapidly at sea as in the river? and if it did not originate in local *malaria*, why should mere change of place have arrested its progress?

In 1808 or 1809, a few frigates cruising off Guadaloupe summoned the small Island of Mariegalante to surrender; and, quite unexpectedly I believe, the Governor capitulated. The place was hastily garrisoned by Marines, who fell sick in vast numbers—men and officers dying rapidly. Nearly every case of this deadly distemper was characterised by the fatal symptom of black vomiting. The temporary Governor, Capt. Hugh Pigot, Royal Navy, now commanding H. M. Ship Talavera in the Downs, alarmed at the dreadful ravages of this fever, did all he could to check its career. As it was generally thought that the disease proceeded principally from some lagoons, or small lakes, surrounded by trees and underwood, bodies of negro slaves were employed to fell timber, burn the bushes, and make a freer passage for the circulation of air. Whether these precautions had any effect or not, is, perhaps, immaterial, so far as relates to the question of *contagion* or *malaria*: but one fact respecting this epidemic is remarkably applicable, namely, that in the instances of a few officers who were so fortunate as to get on board some of the ships-of-war, the fever was instantly checked, and they were almost the only cases of recovery. It should also be observed, that notwithstanding many of these sufferers were taken on

board in nearly the last stage of the disease, yet in no case did they communicate the fever to the shipping. One marine officer, (whose name I cannot at this moment recollect, but which might easily be found by referring to the ship's books at the Admiralty,) being very ill with the fever at a detached station called Vieux Fort, gave orders to his men to put him into a canoe, in which he was rowed on board the *Ulysses*, of 44 guns, commanded by Capt. C. J. W. Nesham, who now commands the *Melville*. The patient declared that he began to revive while in the canoe, as he believed from the effects of sea air, and he recovered rapidly after reaching the ship. Yet no officer or seaman belonging to the *Ulysses* had any attack of fever—Where then was *contagion*? The patients who remained on shore nearly all perished, while those who were lucky enough to reach the shipping recovered invariably—Can any thing but *malaria* account for this?

In 1807 or 1808, H. M. Ship *Ulysses*, of 44 guns, Capt. Nesham, reached Barbadoes with a convoy from England. One of the midshipmen named Thomas Wood, with whom I was most intimate, went on shore to look at Bridge Town, and was immediately seized with yellow fever. The next morning I attended him to the hospital. My poor friend was in a raging delirium, and as I held him partly in my arms while in the boat, the black vomit came on, which he ejected over my hands and clothing. Yet I had no attack. Where then was the *contagion*?—When Capt. Bouchier commanded the *Medina* sloop-of-war in the West Indies, he anchored upon one occasion in Carlisle Bay, Barbadoes, close in under the land, opposite to the old naval dock-yard. Here his men fell sick so fast, that he was induced to move the vessel to another anchorage at a considerable distance farther from the shore, when the fever immediately abated! Was it not, therefore, occasioned in the first instance by *malaria*, the influence of which ceased upon changing the ship's position? or if the disease was propagated by *contagion*, why should it abate upon merely shifting the anchorage?

I remain, &c.
SENEX.

The Band of Gentlemen Pensioners.

MR. EDITOR.—Some discussion having arisen lately as to the corps of Gentlemen Pensioners, allow me to observe that in the present days of economy and retrenchment, it is really "too bad" that the country should be put to a heavy expense in paying a party of London tradesmen for acting as *Gardes du corps* to his Majesty, whilst so many hundreds of veteran officers, who have spent the best part of their lives in his service abroad, and therefore are his fittest guards at home, would be proud and delighted to be allowed that privilege. Let the vacancies, as they occur, be filled up in future by his Majesty in person from amongst the veteran half-pay officers of the Line and Marines; let none be appointed who have not been more than once actually engaged with the enemy; let them be officered by retired general officers, and, if it should be thought advisable, let them be under the same restrictions as to personal appearance, height, &c. as the picked corps in the army; and then the Sovereign would be guarded by the *élite* of his veteran soldiers, and we need not be ashamed of pointing out to foreigners our British *Gardes du corps* for fear of exciting their laughter at such an awkward squad of respectable citizens as now do that honourable duty. Our kind-hearted Monarch would be delighted to have it in his power thus to reward those who have deserved so well of their country, whilst the people would see with pleasure that those who had done their duty in the camp were still distinguished at the court.

H.

Proposition for a United Service Medical Society.

MR. EDITOR,—Will you permit me to recommend, through the medium of your Journal, the establishment of a society consisting of the medical officers of the army on full and half-pay, which might be denominated, "The Medical and Physical Society of the British Army." A similar society or association was established a few years since, viz. "The Medical and Physical Society of Calcutta," which comprehends a very considerable portion of the Medical Department of Bengal, and several members of the Madras and Bombay Presidencies, amounting altogether to from 200 to 300 members. The society is, I believe, patronized by the members of the Medical Board of Bengal, a patronage which does the Board much honour; it evinces a liberal spirit, and a disposition to encourage measures which have a direct influence in promoting the improvement of the officers under their superintendence, and the advancement of medical science. The Medical and Physical Society of Calcutta has already published four volumes of Transactions. When so much has been effected in so short a time by the Medical Establishment of the Bengal Presidency, what may be expected from a society embracing the Medical Department of the British Army?

"The benefits of occasional publication are in no case more evident than in the science of medicine. Amidst the varied opportunities for observation which its unbounded sphere of action develops, many circumstances of a peculiar character, many conclusions of wide applicability must occur to individual practitioners. The experience of its professors is the common property of the profession; but incidental reflections may be too brief for formal record—a solitary fact too unsafe a base for generalization, and therefore neither the one nor the other would be communicated to the world, unless there existed some unpretending repository in which they might be registered for farther verification or correction. Periodicals are to us what the tables in the temples of Esculapius were to his ministers, with all the advantages derivable from the improved nature of the medium, and the more justly grounded doctrines of modern practice."—*Preface to the 1st volume of the Transactions of the Medical Society of Calcutta.*

The primary purpose of medical societies is professional improvement, viz. improvement of the individual members, and improvement of the science of medicine. The general amount of improvement will, perhaps, depend more on the numbers that write, than upon the quantity written. Medical men, whether they belong to the army or not, should consider it an incumbent duty to record whatever remarkable facts may come under their observation, which they may think entitled to the attention of other members of the profession. Those who endeavour to improve themselves in this way, cannot fail to promote the welfare of their patients, and advance medical science. Those who record facts will carefully observe phenomena; patients will be benefited in the first instance by assiduous observation, and eventually the advantages will extend to the profession.

The society might be so constituted as to include the medical officers of the Royal Navy, when it should be denominated "The United Service Medical and Physical Society."

The following is an estimate of the probable number of medical officers entitled to become members of the society, viz.—

Regimental Medical Staff, full-pay	350
Ditto half-pay	264
General Medical Staff, full-pay	140
Ditto half-pay	254
Ordnance Medical Department, full-pay	38
Ditto half-pay	54
Medical Officers of the Royal Navy	1100
	<hr/>
	2200

This is a very extensive field for recruiting a numerous and efficient society. When we witness a few medical practitioners in provincial towns supporting respectable periodical publications, can it be doubted that the combined exertions of the medical officers of the army and navy would produce a body of transactions that might reflect the highest credit upon the members of the departments to which they belong? The literary and professional attainments of the medical officers of the army and navy are not inferior to the qualifications of practitioners in civil life. During peace they have commonly more time at command, and in many other respects they have infinitely better opportunities for collecting and communicating interesting information. Why should these excellent, and in some measure, peculiar advantages, be thrown away or allowed to remain inoperative?

The leading object of the society should be the advancement of professional knowledge, more especially in regard to the means of preserving the health of soldiers and sailors, and of treating them under disease. Natural history would, almost as a matter of course, receive a considerable degree of attention. Under these general heads are included, Military and Naval Hygiene, the Meteorology and Medical Topography of different countries, the diseases of particular races of mankind and climates, descriptions of animals and their diseases, &c. &c. &c.

Our medical literature is remarkably deficient in general practical instructions regarding the initiation and conduct of young men who are entering upon the practice of the medical profession. For example, we have no work which comprehends a full detail of the duties of an assistant-surgeon in the army or navy, calculated to instruct a young medical officer upon entering either of the services to which he may belong. To be more specific,—where will he find instructions respecting the duties of a medical officer upon a “punishment parade,” or when a sailor is “brought to the gangway.” I need not point out how important it is for a young medical officer to be instructed in the nature of those duties before he is called on to execute them—how apt he is to go wrong—and how culpable he may appear to be, when he is only uninformed.

Essays or observations on these topics by Veterans of the army and navy are much wanted, and would perhaps appear upon the formation of a United Service Medical Society.

A library and a museum might eventually form part of the establishment.

Every facility should be afforded, not only for the publication of the elaborate communications of members, but even for single facts derived from cases, which in other respects may not be very remarkable, or detached observations upon points of duty, more especially when communicated by officers of long experience.

I sincerely hope that the members of both establishments, who are anxious for their own improvement, and the respectability of the service in which they are engaged, will bestir themselves for the purpose of forming an association, and I trust its promoters may reckon on your assistance to circulate an address to the medical officers of the army and navy in your excellent periodical.

As the object of a United Service Medical Society would be intimately connected with the public good, perhaps the Secretary-at-War would grant permission for the communications of members being conveyed through his office, for the purpose of saving postage. There can be no harm, at least, in soliciting this boon, and a great boon it would be.

DUKUM DARAH.

EDITOR'S PORTFOLIO ;
OR
NAVAL AND MILITARY REGISTER.

AFFAIRS AT HOME AND ABROAD.

—THE majority of the House of Commons having persevered with success in maintaining what they conscientiously considered to be the rights and interests of their constituents, and the integrity of the British Constitution, the Parliament was precipitately, and, on the part of the Ministers, oppressively and insultingly dissolved. The predicament of HIS MAJESTY, thus rashly and incapably advised, has awakened the fears and roused the vigilance of his loyal subjects.

The truth appears to be, that a new phase of government exercises a direct influence upon the affairs of this moon-struck nation. The British People, of a noble but credulous nature, has virtually passed under the domination of a trading Oligarchy, represented by the Newspaper Press. Abroad, this novel and absolute Power has been inaugurated as the Reign of Journalism: in England, our "Thirty Tyrants" are less royally inducted as the Printing House Parliament.

IRELAND, more liberal than Liberalism, is busily occupied with her own "Dissolution," both social and political.

FRANCE has at least succeeded in discovering a perpetual motion in politics. Fresh *emeutes* have been only suppressed by military force, somewhat more vigorously applied than usual by the Perrier Ministry, who are also about to give a fresh impulse to the "*Mouvement*," by dissolving the French Parliament.

U. S. JOURNAL, No. 30. MAY 1831.

BELGIUM, still blatant and blundering, has thought to redeem her follies, and console herself for rejection where her affections were bestowed, by offering her tinsel crown, as a *pis-aller*, to Prince Leopold. Whether His Royal Highness will consent to unite himself to so rickety a partner is not yet positively announced.

The ITALIAN insurgents have, in the late, as in former instances, played the part of Punch with characteristic felicity. They ran away, as a matter of course, from the Austrians, and now complain, with some show of reason, that their Gallic neighbours, having first excited them to revolt, left them at last in the lurch. Italy, for the present, is appeased; and the Pope promises to ameliorate the political condition of his States. His Holiness, we hope, will keep his word, however unworthy of the boon his recreant flock may be.

POLAND alone, setting aside the proximate causes of her revolt, presents a spectacle claiming unmixed admiration. To the soldier's glance, the attitude of her martial people is especially striking, and replete with interest. Proposing to give, from our own sources, a complete narrative of the illustrious transactions of this national war, divested of the absurdities with which exaggeration and prejudice obscure its passing details, we shall offer only a few general remarks on a subject so familiar.

The breaking up of the frost, by which the roads and rivers of

Poland were rendered difficult or impassable, was a providential interposition for its defenders, who, in the ardour of patriotism still adhere to the spirit of Religion and the dictates of common sense. Its duration for another week would inevitably have put the Russians in possession of Warsaw, and decided the subjection of Poland. The delay has been of incalculable benefit, in a moral sense, to that gallant People, although no efforts, however heroic, on their part, can, we fear, ultimately arrest the military success of their adversaries. It will be seen, by an original and authentic Memoir of Count Diebitsch, given in our present Number, of what stuff that General is made; nor are we justified in assuming, that a commander, so practised and endowed, should suddenly cease to give proofs either of ability or experience;—especially before an antagonist, who, however brilliant in sudden action, and favoured by circumstances, is yet wholly unused to direct systematically the great operations of his art.

It appears that in the latter end of March, Count Diebitsch, foiled by the thaw, having made demonstrations of manœuvring to his left upon the Upper Vistula, and detached, with that view, the First corps under Count Pahlen and the division of Guards of the Grand Duke Constantine, while his headquarters remained at Zelichow and Ryki on the 29th ult. and 3rd. April; the Polish Generalissimo, with equal enterprize and judgment, effected a forward night movement from Praga with great secrecy, and succeeded on the 31st March in surprising and defeating the corps of General Geismar posted at Wawer. Following up his success, he also, after some prudent hesitation, fell upon the corps of General Rosen, occupy-

ing a position still farther in the rear, over which he also gained advantages on the first of April at Dembi-Wielki.

Since those events, a series of active operations have ensued, and an important diversion has at least been secured by Zkrzynecki in the partial revolt of the Polish Provinces in the rear of and around the Russian armies. In a military view, however, the advanced position of the Polish General, operating on a line perpendicular to that of his opponent, his flanks exposed and his communications liable to be cut off, while Warsaw is uncovered, cannot be considered otherwise than critical;—assuming that his skilful adversary has not altogether lost his head, that he commands superior resources, that his principal masses are unbroken and re-uniting, the first corps and Guards not having, in fact, been engaged, and that the season once more favours their concert and offensive operations. General Rosen had fallen back on a fresh corps, taken post on the Liewiecz, and checked the farther advance of the chivalrous Pole.

A decisive shock of some kind between the contending parties must speedily take place, if the war be prosecuted.

ROYAL ASTRONOMICAL SOCIETY.
—April 8.—Francis Baily, Esq. V.P. in the chair.—A communication from the Astronomer Royal was read on the obliquity of the Ecliptic. The corrections hitherto used in the calculations of the sun's declination, were by the tables drawn up by Bradley. Mr. Pond having found some small differences, has constructed new tables, which were presented to the Society with the above communication. A paper was read on the construction of glass lenses for achromatic telescopes, communicated by a French artist. The progress made in this art, and the extent at which it has arrived, were detailed, as well as the desiderata

which were still required to render it perfect. In alluding to the works of the British manufacturers, it was observed, that our countrymen were too fond of aiming at being mathematicians, instead of opticians, and that the consequence was the backward state of art in this country. A letter from M. Cauchoix to Mr. R. Sheepshanks, was read, informing him of his having completed an achromatic telescope, with an object glass of thirteen inches and a fraction in diameter. The focal length of this telescope is twenty-four feet, exceeding by six feet that of Sir James South at Kensington. It was also stated that it had been examined and approved by the French astronomers. Part of a paper was also read on La Caille's Catalogue of Stars, communicated by Mr. Baily,—this gentleman having accidentally met with a copy of this very scarce work, and aware of its value, presented it to the Society with the above paper. The indefatigable labours of this French astronomer were carried on at the Cape of Good Hope under no favourable circumstances, about the middle of the last century; and in consequence of his want of money, few copies of his work were given to the world. A general review was taken of his works by Mr. Baily, which will be concluded at the next meeting.

ROYAL GEOGRAPHICAL SOCIETY.

—At a meeting of this Society, Lord Goderich, president, in the chair—Two very important intimations were read from the chair. 1. It having been suggested to the council, by several members of the Society, that its objects would be materially advanced if committees were formed for the prosecution of particular branches of research, and the council highly approving of this suggestion, resolved, that members who may feel inclined to assist in carrying the plan into effect be invited to communicate with the secretary regarding it. And, 2. That if any of the members present at the ordinary meetings of the Society, wish, after the business of the evening is concluded, to make brief remarks, or put inquiries, respecting the subject of the paper which has been read, or are able to communicate further infor-

mation regarding it, they are invited by the council to do so, and the meeting will be happy to attend to them. Both these measures are, we believe, close copies of what has been long practised, and with excellent effect, in the Geological Society. The Committees, by bringing the working members of the Society together, have given unity of purpose to their individual labours: and their *visà voce* communications with each other at the ordinary meetings, have both disseminated information among the other members, and greatly extended the interest taken by them in the general proceedings of the Society. Three Committees were afterwards mentioned as at present more immediately contemplated; and the utmost readiness was at the same time expressed to form others, if members would come forward to suggest and join them. 1. A statistical Committee, which should make the vast subject of statistics its especial object, and thus supply, in this country, the place of a statistical Society, as established in Paris. 2. A colonial Committee, which should direct its attention either to the British colonies alone, or to colonies generally, as might afterwards be agreed on. 3. A Committee which should take up some one kingdom or province in the world, and compile a complete account of it in every respect, as an example on which others might be afterwards similarly proceeded with.

April 11.—W. R. Hamilton, Esq. V. P. in the chair. A letter addressed to the Society by Mr. Jones, was read, explaining the construction of a portable barometer, lately invented by him, made entirely of metal, consequently not so liable as the ordinary glass ones to be accidentally injured or destroyed; and possessing, at the same time, some other advantages. The height of the mercury, although enclosed in an opaque tube, is ascertained by means of a float on its surface, having a needle which rises through a small hole in the otherwise close cover of the tube; and a double stop-cock nearly in the neck of the siphon, either entirely closes in the mercury when the instrument is put away, or more or less, at will, contracts its thread when about to be

consulted at sea, and when, consequently, the motion of the vessel may make the use of the entire column inconvenient. The thanks of the Society were voted to Mr. Jones for his communication: and the invention appears calculated to be a real improvement in the equipment of scientific travellers. A paper was then read, giving an interesting account of a visit to the city of Marocco and the Atlas mountains, with observations made during a month's residence at the former place, in the winter of 1829-30, by Lieut. J. Washington, R.N. Leaving the town of Tangier, after passing over a country with few signs of cultivation, and only varied by an occasional Arab village, the party forming the embassy which Mr. Washington accompanied, about dusk reached their first encampment, which they found already prepared for them. The tents were arranged in the form of a circle, with the baggage placed in the centre. Conspicuous above the rest was the tent of the Moorish leader, striped blue and white, and surmounted by a gilt globe,—horses and mules were picketed around—here and there were scattered groups of Moors, their swarthy faces lighted up by the watch-fires over which they were reclining, assisted by the light of the broad full moon, rising above the distant mountains; and the scene completed by the moslems chanting their evening prayer. The town of Al Ksar, through which the embassy passed, is remarked by Lieut. Washington as the only town in Barbary where houses have ridged roofs of tile. The population of Marocco is estimated by Lieut. Washington at from 80,000 to 100,000, 5000 of which are Jews. The vast plain on which it stands extends in an east and west direction, between a low range of hills to the north, and the lofty Atlas to the south, rising abruptly to the height of 11,000 feet, its summits covered with snow. This plain, which has no limit east and west as far as the eye can reach, is 1500 feet above the level of the sea. The city is surrounded by a wall, and is about six miles in circuit. Nineteen mosques were observed, the principal one standing in a deserted space of about twenty

or thirty acres, and conspicuous above all from its lofty square tower, rising to the height of 220 feet. Being of the same dimensions from its base to its summit, it has a very peculiar effect. It is divided into seven stories, and its height is about seven times its diameter. Traces were found of much greater population than the present; and the effects of the plague and famine, by which Marocco was visited a few years since, are proved by the numerous untenanted houses and vacant spaces. Not more than half the space within the walls is now inhabited. The height of Mount Atlas, according to Lieut. Washington, is 13,400 feet above the level of the sea; in which he differs widely from Jackson, who estimates it at more than double that height. In ascending this range, a race of people were found of a character very different from the Moors or Arabs. The contrast between these primitive mountaineers and the apathetic Moors is remarkable: they have an air of freedom about them, are well-formed athletic men, not tall, and with light-coloured complexions; they do not understand Arabic, and mix very little with the inhabitants of the plains. Their chief occupation is hunting, and they dwell in cottages built of stones and mud, with slated roofs. They are considered by Lieut. Washington as a very interesting race of men, of whom, like the recesses of the Atlas wherein they dwell, nothing is known. The party ascending the Atlas were disappointed in their hopes of reaching the summit; for, having fairly attained the region of snow, the guides refused to attend them further, and they reluctantly halted, at an elevation of only 6400 feet. The geological formation of the Atlas is described as consisting of hard sandstone strata, lying in an east and west direction, dipping at an angle of 10° to the southward. Limestone, schist, and sandstone were only seen, but with no traces of primitive rock, excepting a boulder of granite, or rather gneiss, in the valley below, and veins of foliated quartz in the schistose hills. The tendency of the formation is to table land, ridges, and rounded summits, not to sharp peaks. No trace of volcanic

agency was seen, nor any thing in the outline of the Atlas indicating the formation of a crater. The whole extent of country from the foot of the Atlas range to the sea, is one vast plain, which it would be easy to cultivate. Mr. Washington observes, that if a proper direction were given to the water, which is not wanting on its surface, abundance would spring up where weeds only prevail, affording food to millions of inhabitants. He is also strongly of opinion that attention should be directed to opening a trade with this country, the effects of which would be most beneficial to England. The thanks of the Society were voted for these very interesting papers. A map of Marocco, constructed by Lieut. Washington from his own observations and the best maps and charts extant, together with panoramic views, taken during his journey, of the country through which he passed, as well as of Mount Atlas, were laid before the Society during the reading of the above paper.

CIRCULAR STERNS.—It will doubtless be a source of satisfaction to our naval readers to be informed, that after all the controversy, extensive alterations, and melancholy results, attending the attempts hitherto made, at an efficient and ship-shape circular stern, that great object is at length satisfactorily attained, and applied to the *Chichester*, 52, at Woolwich. The advantages of the circular over the square stern are, that in action it leaves no point of impunity in attack or defence, and that the vessel's frame is bound firmer together, thereby adding force, with reference to the guns, and strength, as regards architecture. The circular stern hitherto fitted to some of our best ships, has, in the opinion of good judges, actually injured them, in consequence of taking from their length, and exposing the rudder head; as also being loaded with cumbrous stern walks. The stern of the *Chichester* has none of these objections; she is more roomy than if fitted with a square stern, bouses her rudder head, works her stern guns equally well with those on the broadside, and has no heavy gingerbread nonsense in the shape of those more than ridiculous stern walks, which, if

not knocked away before firing the stern guns, are sure to take fire.—In short, the circular stern is now as it should be; its pleasing simplicity excites admiration, and defies criticism, leaving us only to regret and wonder it had not been sooner adopted, to the saving of so much time, expense, and efficiency.

THE OFFICERS OF THE EAST INDIA COMPANY'S SERVICE, AND THE JUNIOR UNITED SERVICE CLUB.—In consequence of no less than six officers of the East India Company's Service having been black-balled at the Junior United Service Club, a requisition for a General Meeting was sent to the Committee, and a Meeting to discuss the subject was held on the 12th of April. We subjoin the address of an old and gallant veteran officer, Colonel Nugent; as it was received with extraordinary enthusiasm by the Meeting, and may be productive of more cordiality for the future.

“Mr. Chairman,—I do not believe any person can address you with more propriety than I can on the subject of this Meeting, having had the honour to serve both His Majesty and the East India Company, and bearing the most sincere regard and respect for both services. Seventeen years of the early part of my life were passed in India, where, for five years, I commanded what is now called a regiment, but was then named a battalion of native troops. It was my lot during that period, on one memorable occasion, to serve with His Majesty's troops, with the 2d battalion of that glorious regiment the 42nd, now named the 73rd, and bearing on its colours the word *Mangalore*, as an honourable memorial of their services. It was commanded by Lieut.-Colonel John Campbell, who also commanded the garrison, and whose name deserves to be immortal, though he only survived for three weeks the extraordinary perils and fatigues he had undergone, and his memory is dear to every British soldier.

“Gentlemen, we were besieged, in a fort scarcely defensible, by Tippoo, with 100,000 men and 100 pieces of cannon, assisted by a French regiment and French engineers. He failed, by breaching and repeatedly storming, to take the place; but we were the victims of a treacherous cessation of arms during negotiations for peace, and were literally starved out of the place, when, of 2700 men, of which

the garrison originally consisted, only 350 marched out bearing their arms. Gentlemen, had you witnessed, as I did, the harmony and cordiality that existed not only between the King's and Company's officers, but also between the brave Highlanders and the poor Sepoys; had you seen them fighting in the same battle, bleeding together, and often buried in the same grave; you would not refuse to the Company's officer returning to this country with a limited income, and often a shattered constitution, a happy home like this. And I can assert, from my own personal knowledge, that there are many, a great many more officers in that service who would be equally distinguished had they the same opportunities.

I have heard it observed that the Company's officers have the Oriental Club to go to, and so, Gentlemen, have they the Albion tavern to go to, if their purses can afford it. But I am sure you will be glad to learn from me, who belong to the Oriental, that, by the good management of your officers, your annual subscription and coffee-room charges are at least fifty per cent. below those of the Oriental.

"But there is another point of view, Gentlemen, in which I must beg you to consider this subject.

"By your Prospectus, and by your Regulations, you invite the officers of the Company's army to join you. Several of them assisted in forming this Club, and some on your Committee have assisted to conduct it. Now I will only put it to your feelings whether it is just, or I might almost say honourable, to refuse them, in this pointed manner, admission to your Society. Your Army List will show you the proud list that have adorned that service, and I am certain there is not, in this room, one who has not heard of Sir Thomas Munro, Sir John Malcolm, Sir David Auchterlony, Sir Barry Close, and many others equally distinguished.

"I am therefore fully satisfied, that, on all future ballots, you will not make the smallest difference in your election between the services, and prove to the Company's officers that no hostile feeling towards them prevails in the United Service Club."

DUBLIN BAY REGATTA.—The inhabitants of Dublin purpose giving a most splendid Regatta, towards the end of June, to compliment the Marquis of Anglesey, on his return to Ireland. With so magnificent a Bay as that of Dublin—abounding with scenery, only inferior to that of Naples

itself, and with an opulent and *spirited* city to back it with subscriptions to any amount, it is only astonishing that the most valuable prizes in the United Kingdom have not been offered to our nautical amateurs from that port.—Dublin Bay is a *centre* wherein vessels from Scotland—the North of Ireland—Liverpool—the Isles of Man and Anglesea—the Welsh coast as far as Milford, and the South of Ireland, could conveniently meet and enter into honourable competition, to say nothing of vessels from the South of England and the "Royal Yacht Club," whose attendance has hitherto been numerous. It is fully expected that his most gracious Majesty, the Sailor King, will be pleased to present a most splendid challenge cup, to be run for by vessels of all classes.

RECRUITING.—The standard of recruits of the Scotch National Regiments, the 21st, 92nd, and 93rd, has been reduced to five feet five inches and a half.

STRENGTH AND ORGANIZATION OF THE RUSSIAN ARMY.—The Emperor is the supreme chief of the Russian army, and he takes the command himself of it in time of war. The Field Marshals are under his immediate orders. The allowances of the superior officers are very moderate; they have, however, certain expenses allowed them for a table, and some other emoluments, which are augmented in various ways; for in this venal nation, a public functionary, whether military or civil, rarely lets slip an occasion of turning to account the opportunities afforded by his station. The pay of the subaltern officers is remarkably insufficient, and many must in some shape make a sacrifice to their country in serving as lieutenants or captains of cavalry, especially in the Guards. In order to become an officer there must be proofs of nobility, and of having been previously admitted to a military institution; but private soldiers, nevertheless, may become officers, and even the higher military honours are not inaccessible to this class. The sub-officers of the Guard frequently pass into the army of the line with the rank of ensign, and every officer of this rank may become a ge-

neral. The pay of a private soldier does not exceed 30 francs (1*l.* 5*s.*) per annum, out of which there are several reductions. He receives, besides, some articles of food, and every year a uniform. The Russian soldier, however, with his miserable pittance, is happier than if he had remained a slave. This feeling greatly facilitates the recruiting of the army.

The recruiting is carried on, generally, every three years, amongst the artisans and peasants. The army is only composed of freemen, and every serf is emancipated by the simple fact of his entering into the service of the state. The yoke, however, is in reality not got rid of, but merely changed from that of the glebe to a harassing, and frequently capriciously cruel discipline. The ordinances for recruiting affect all men indiscriminately belonging to the two classes pointed out, if under forty years of age, whether married or not. Sometimes, however, some of the tribes are exempted from this operation, in consequence of their being either too distant or too few to be exhausted by recruiting. In ordinary times one out of every 500 males is taken, but during war, two out of every 500, and, in case of urgency, four out of the same number. The ordering these levies is regulated by the last census, which is sometimes that of eight or nine years previous.

The Cossacks, whose obligations and privileges are regulated by treaties, place at the disposal of the Emperor the number of troops which they undertake to furnish, and are not included in the recruitment.

The German colonists in Russia are also, in general, exempted; and, like the privileged classes, only enter the service when it suits them. The males who furnish the new levies do not exceed 24,000,000, from which must be deducted all those whom the Government send to their lords, for a sum of from 1,500 to 2,000 francs. A levy, therefore, of two in every 500 males, does not produce more than about 90,000 men. At any particular crisis the militia can be summoned under arms, which, in case of need, can be increased to 250,000 men.

The following list gives the Russian

army as it was in 1827. Since the Turkish war Russia has made the greatest efforts to repair its losses, and the army may be now considered as on the same footing as at that epoch, its operations being directed by the same Generals-in-Chief:—

1ST, IMPERIAL GUARDS.	
8 regiments of infantry, each consisting of 3 battalions, comprising 2,400	19,200
Battalions of sappers and foot artillery	2,000
8 regiments of cavalry, each 800	6,400
Cossacks and petards, 3 squadrons	800
Pioneers and horse-artillery	800
Total Imperial Guards	29,200

2ND, INFANTRY OF THE LINE.	
127 regiments of grenadiers, fusileers, and chasseurs, each three battalions, 2,400 men	304,800
36 battalions of garrison troops	77,000
Total Infantry	381,800

3RD, CAVALRY.	
16 regiments of Cuirassiers, each 5 squadrons and 1,000 men	16,000
52 regiments of Dragoons, Hussars, Hulans, and Chasseurs, each from 5 to 10 squadrons and 1,000 men	52,000
32 regiments of regular Cossacks, 18 of Cossacks of the Don, 10 of Cossacks of the Black Sea, 10 of Cossacks of the Ural, 3 of Cossacks of the Volga, and the Cossacks of Siberia, the Kalmucks, the Tartars, the Bachkins, and Caucasians	100,000

Total Cavalry, regular and irregular	168,000
--	---------

4TH, ARTILLERY.	
60 companies of artillery for sieges, 200 each	12,000
60 companies of field artillery, 200 each	12,000
22 companies of horse artillery, 200 each	4,400
12 companies of pioneers, 200 each	2,400

10 companies of pontoneers, 200 each	2,000
12 companies and 62 artillery commands in interior gar- risons	11,500
Total artillery	44,300
Extra corps	27,000
Total of the Russian army	650,300

Add to this number about
20,000 officers of all ranks,
gives a general total of . . . 670,000

This number was borne upon
the registers of the army
before the extraordinary
levies of 1827 and 1828.
The number was then rather
nominal than effective,
but it was then carried on
to its completion, and the
Russian army was increased
by 200,000 men, making
the whole 870,000

This immense number, which is at
present under arms, is divided into
eight armies, each consisting of three
or more corps. That of the Imperial
Guards are under the orders of the
Grand Duke Michael; the army of the
south, quitted by Count Witgenstein,
is commanded by Count Diebitsch;
that of the west by Count Osten-
Sachen; the Lithuanian army by the
Grand Duke Constantine; the separate
corps of Caucasus by Count Pas-
kewitch-Erivanski; the army of the
Grand Duchy of Finland by General
Zakrefski; the military colonies by
General Tolostoi. There are also
corps de reserve in the environs of
Moscow and St. Petersburg, in case of
emergency. From the whole amount
must be deducted about 60,000 men,
the contingent of the new kingdom of
Poland now in arms against Russia,
and also the Lithuanian army and the
other troops levied in the ancient ter-
ritories of the Polish republic, which
can now scarcely be included in the list.

The military force of Russia, how-
ever, is not near so great as it appears
upon paper, it being a monstrous aggre-
gation of conquered nations, a part of
whom must necessarily be employed to
keep the others in subjection. Russia,
no doubt, recruits in Poland, in Fin-

land, amongst the Tartar tribes of
Casan and the Crimea, in Caucasus,
and amongst the Nomades of Northern
Asia, but the population in these ter-
ritories must be kept down by corps
of troops more or less considerable.
In Asia detachments are stationed
along an immense line at two or three
leagues' distance from each other, from
Kasan to Kamschatka. Russia is, be-
sides, obliged to watch her neighbours
by means of great corps d'armée.
Thus, for instance, the Russian Am-
bassador at the Court of Teheran had,
for some time, the command of the
military forces stationed on the fron-
tiers of Persia, in order that he might
make an impression on that Power in
his double character.

Russia, therefore, notwithstanding
the apparent number of her fighting
men, can scarcely bring into the field
so many soldiers as Prussia. In 1813,
when she made the greatest efforts,
she had not more than 300,000 men
disposable, and even that was not ef-
fected but by the aid of subsidies from
Great Britain.

The Russian officers, to eke out
their pay, endeavour to raise money
from merchants and travellers; and it
is not uncommon to see an old Co-
lonel, with four decorations, receive
from a traveller what our mere cus-
tom-house-officers would reject with
indignation. The recruiting in Rus-
sia is effected by means of throwing
the responsibility of furnishing the
men upon the landed proprietors, upon
whom it becomes a serious burden.
By paying from 1,500 to 2,000 francs
per man, they can purchase an exemp-
tion; and in the Turkish war several
courtiers made a traffic of these tick-
ets of exemption, the price of which
was then raised to nearly 3,000 francs.

EXTRAORDINARY LENGTH OF SER-
VICE.—The following letter has ap-
peared in a London Paper:—

SIR,—On perusing a paragraph in your
valuable paper a few days since, I per-
ceive it is said that that distinguished
officer Sir George Don, now at Gibraltar,
is about to be relieved by Sir William
Houston, and that he will shortly return
to England, after having been in actual
employment sixty-two years, without any
interval—a circumstance which has no

parallel in the records of the service of any general whose name is now to be found in the English Army List. In speaking of length of service, however, I beg leave to remark, that of the late Inspector-General of Fortifications (General Mann,) is much more extraordinary, as he was actively employed, without any interval, for sixty-seven years; and, what is remarkable, during that period never had a month's leave of absence. The General's first commission was dated Feb. 28, 1763, and he died on the 27th March, 1830.

NORTON'S RIFLE SHELL.—We were witness to an experiment made by Capt. Norton, at Moore's Shooting Ground, Notting-hill, with his Percussion Rifle Shell, on the 23rd ult. before the Master-General of the Ordnance, Major-General Sir Andrew Barnard, Major-General Norcott, Colonel Fox, and several other officers. The result was quite satisfactory as proving the utility of these projectiles. The object fired at was a small box, of about a foot square, its front being of oak, one inch in thickness, and back of elm, of an inch and quarter; between these was an inclosed space of one inch, filled with powder. The shell was discharged from a military regulation rifle, having the head of its ramrod hollowed out, to prevent pressure on the percussion cap; the distance about fifty yards. The first and second shots missed the object, and the shells passed clear through a broad iron-plate, which clamped together a three-inch boarded screen, against which the experiments were made. The third discharge carried the shell clear through the box, and caused an instant explosion.

LIGHTNING CONDUCTORS.—Most satisfactory accounts have been received from His Majesty's ship Dryad, on the coast of Africa, of a trial of Harris's lightning conductors, in which their utility was manifested beyond a doubt. There had been a great deal of lightning on the coast, and in one instance, the Dryad encountered the fury of a tornado. A heavy flash of lightning struck the foremast, which was seen distinctly to pass down the conductor; at the same time a whizzing noise was heard, resembling the

boiling of water. In a short time after, a second flash was seen, by the officers on the quarter-deck, to strike upon the mizen-mast, which passed off safely, but attended as before with a similar whizzing noise. It does not appear that the conductors sustained the slightest deterioration or marks from the passage of the electrical fluid. This account from the Dryad goes to prove, that the conductors do not draw down upon a ship any dangerous consequences, or attract, as some persons imagine, more electric fluid than they can transmit. Of course, in the tornado mentioned above, there must necessarily have been plenty of electric fluid present to be attracted; so that either the conductors discharged the whole of it, or otherwise only as much as they attracted; if they discharged the whole, with so little effect, there surely can be nothing to apprehend. There can be no question but that the Dryad's masts were saved by the rapidly equalizing power of the conductors, by which the dense, and otherwise overwhelming, stroke was passed. We have only to reflect on the frightful electrical action of a tornado on the Coast of Africa, to conclude that the ship, enveloped (as she must have been) in electric matter, was entirely protected from damage by the influence of her lightning conductors.—*Hampshire Telegraph.*

CHANGES IN THE STATIONS OF CORPS SINCE OUR LAST.—*4th Dragoon Guards at Glasgow; 5th Dragoon Guards from Bath to Dublin; *10th Hussars from Wigan to Prescott; 17th Lancers from Newbridge to Limerick; 2nd Battalion Grenadier Guards from the King's Mews to Upnor Castle; 4th Foot from Northampton to Chatham; 5th Foot from Buttevant to Ennis; 11th Foot from Corfu to Santa Maura; 18th Foot from Corfu to Vido; 18th Foot Depôt from Stockport to Bolton; 19th Foot Depôt from Gosport to Weedon; 30th Foot from Manchester to Ashton and to Dublin; 34th Foot Depôt from Naas to Clare Castle and to Limerick; 35th Foot Depôt from Plymouth to Davenport;

* Under orders for Ireland.

43rd Foot from Portsmouth to Manchester; 49th Foot Depôt from Upnor Castle to Chatham; 51st Foot Depôt from Weedon to Bolton and Stockport; 57th Foot from New South Wales to Madras; 60th Foot 1st Battalion Depôt from Clonmell to Dublin; 76th Foot from Dublin to Limerick; 82nd Foot Depôt from Newcastle-on-Tyne to Sunderland; 87th Foot on passage to Mauritius; 87th Foot Depôt Davenport; 91st Foot Jamaica—on passage home; 97th Foot Depôt from Charles Fort to Clonmell; 98th Foot Depôt from Plymouth to Davenport; 99th Foot Depôt from Clare Castle to Naas.

ARRIVALS, SAILINGS, AND INCIDENTS IN THE FLEET.

Portsmouth.—March 27th. Arrived the Cracker cutter, from Jersey, and the Supply, naval transport, with stores, from Deptford.

March 28th. Arrived the Quail cutter, from Dublin, and the Highflyer, from Newhaven; sailed the Snipe cutter, to the Eastward.

March 30th. Arrived the Starling and Raven, from Newhaven; sailed the Quail, for Dublin.

March 31st. Arrived the Royalist, 10, from Plymouth, and returned on the same day; sailed the Cracker, for Guernsey.

April 2nd. Sailed the Highflyer.

April 3rd. Arrived H. M. S. Rattlesnake, 28, Capt. Graham, from Malta, and the Raven tender, from Newhaven.

April 4th. Arrived H. M. gun-brig Manly, Lieut. John Wheatley, from Bermuda, after four years' service in North America and the West Indies; sailed the Starling cutter, on a cruise.

April 5th. Arrived the Pearl, 18, Commander Blake, from Cork, to be paid off.

April 7th. Sailed the Meteor steamer, for Plymouth.

April 8th. Arrived the Linnet cutter, from Jersey.

April 9th. Sailed the Belvidera, 42, Capt. Hon. R. S. Dundas, with the Consul for Smyrna on board, for Malta.

April 11th. Arrived the Highflyer and Raven cutters, from Newhaven.

April 12th. Arrived the Meteor Steam-Vessel, from Plymouth.

April 13. Arrived the Starling cutter, from Plymouth.

April 16th. Sailed the Highflyer and Raven, for Newhaven.

April 16th. Sailed the Ariadne, 28, Capt. Phillips; Dispatch, 18, Commander Frankland; Nautilus, 10, Commander Lord Geo. Paulet; and Savage, 10, Commander Lord Edward Russell, with sealed orders, which are to be opened off the Lizard. The Starling cutter to the Eastward. The Actæon, 28, Capt. Hon. F. W. Grey, went out of harbour.

April 17th. Arrived the Highflyer and Raven cutters, from Newhaven.

April 18th. Sailed the Linnet cutter, and Meteor steam-vessel, for the eastward.

April 19th. Sailed the Highflyer and Raven cutters, for Newhaven.

April 20th. Arrived the Meteor steam-vessel; sailed H. M. S. Actæon, Capt. Hon. F. W. Grey, for the Mediterranean; also H. M. S. Samarang, Capt. W. F. Martin, with a party of 84 Marines, for Tynemouth Castle.

April 22nd. Arrived the Highflyer and Raven cutters, from Newhaven, and the Snipe cutter, from a cruise.

April 23rd. Sailed the Highflyer and Raven cutters, for Newhaven.

In the Harbour.—Asia, Royal George, St. Vincent, Wellesley, Pallas, Rattlesnake, Pearl, Brisk, Recruit, Meteor.

Plymouth.—March 24th. Sailed the Gannet, 18, Commander Sweney, for Bermuda.

March 25th. Arrived the Royalist, tender to the Caledonia, from Portsmouth, with the marines lately belonging to the Thetis.

March 27th. Sailed the Briseis packet for Falmouth.

March 29th. Arrived the Trincolo from Cork, and came into harbour to be paid off, having been on shore, and damaged her hull, &c. Also the Columbia, Lieut. Ede, from Falmouth.

April 2nd. Arrived the Martial, gun-brig, Lieut. M'Kirdy, from the Coast of Scotland; and sailed on the 3rd for Sheerness.

April 3rd. Arrived the African steam-vessel, Lieut. Harvey, from Woolwich; and sailed on the 4th for Falmouth.

April 6th. Sailed the Sandwich Packet for Falmouth.

April 7th. Arrived the Meteor, steam-vessel, Lieut. Symons; and Starling tender, from Portsmouth.

April 17th. Sailed H. M. steam-vessel, Carron, Lieut. W. F. Lapidge, for Lisbon.

April 19th. Arrived the Royalist, 10,

(tender to the *Caledonia*.) from Falmouth.

Remaining in Hamoaaze—*Caledonia*, *Revenge*, *Dublin*, *Druid*, *Stag*, *Orestes*, and *Columbia* steam-vessel.

At the Island—*Royalist*.

Falmouth.—March 26th. Arrived Hope packet, Lieut. Wright, from Tampico—sailed 25th Jan.; *Vera Cruz*, 2nd Feb.; and from the *Havannah*, 23rd Feb.

March 27th. Arrived the *Briseis*, Lieut. Downey, from Plymouth. Sailed H. M. *Ketch*, *Vigilant*, Lieut. Loney, for Lisbon, with a mail.

March 28th. Arrived H. M. Steamer *Columbia*, Lieut. Ede, from the Mediterranean—sailed from Corfu, 6th March; *Malta*, 12th; *Gibraltar*, 21st; and from *Cadiz*, 22nd.

March 29th. Sailed H. M. Steamer *Columbia*, Lieut. Ede, for Plymouth.

April 6th. Arrived the *Emulous* packet, Lieut. Croke, from *Carthage*—sailed the 1st Feb.; *Jamaica* 22nd; and from *Crooked Island*, the 3rd of March. Also H. M. Steamer *African*, from Plymouth.

April 8th. Sailed the *African Steamer*, Lieut. Harvey, with mails for the Mediterranean.

April 9th. Sailed the *Hope*, Lieut. Wright, for *Jamaica* and *Carthage*; and *Briseis*, Lieut. Downey, for *Halifax* and *Bermuda*.

Foreign.—The *Britannia* (with the flag of Sir Pulteney Malcolm), *Melville*, *Scylla*, *Ferret*, and *Rapid* were at *Malta* on the 12th of March. The *Raleigh* sailed on that day for *Tunis* and *Naples*. The *Procris* was at *Corfu*. The *Pelican* sailed from *Malta*, on the 28th of March, with dispatches. The *Rapid*, from *Archipelago* to *Malta*, experienced a heavy gale of wind, lasting five days, under storm top-sails. The *Alligator*, and *Meteor* (surveying-ship) were at *Smyrna*.

The *Tyrian* arrived at *Honduras* from *Falmouth* 24th January. The *Hope* arrived at *Tampico* from *Falmouth* and *Vera Cruz* 12th January.

The *Dryad*, 42 guns, *Commodore Hayes*, and the *Favourite*, 18 guns, *Commander Harrison*, were at *Sierra Leone* on the 20th January. The *Plumper*, gun-brig, had arrived there with a *Portuguese slaver*, having on board 500 slaves and 40 *Portuguese*. At the time of the capture, the *Plumper* had only six white men on board.

The *Lyra* arrived at *Madeira* from *Falmouth*, 22nd of February, and sailed on the 23rd for *Brazils*. The *Hind* arrived at *Constantinople* from *Napoli di*

Romania, 14th of February. The *Echo* steamer, arrived at *Gibraltar* from *Falmouth* and *Cadiz*, 17th of March, and sailed on the 18th for *Malta*. The *Meteor*, *Mastiff*, and *Philomel*, were at *Smyrna* 19th of February; the *Alligator* had sailed for the *Dardanelles*.

The *Cordelia* arrived at *Bermuda* from *England* 28th of February. The *Galatea* sailed from *Jamaica* for *Vera Cruz* 24th of January. The *Childers* arrived at *Lisbon* from *Portsmouth*, 20th of March; and the *Cygnet* from *Falmouth*, 25th of March.

The *Gloucester*, 74, Capt. Coffin, was paid off at *Chatham* on the 28th of March.

Letters from *Barbadoes* to the middle of February state that a court-martial had been held on board his Majesty's ship *Shannon*, 46, Capt. B. Clement, by order of Vice-Admiral Colpoys, to try *Commander Charles H. Williams*, of his Majesty's ship *Racehorse*, 18, on charges preferred against him by supernumerary *Commander William Oldrey*, who was ordered a passage in the *Racehorse*, to join his Majesty's ship *Winchester*, at *Jamaica*, for conduct towards *Commander Oldrey*, having a tendency to bring him into disrespect as an officer of his Majesty's navy. Several of the officers of the *Racehorse* were examined by the court, which, after sitting four days, adjudged *Commander Williams* to be fully acquitted.

The *Revenge*, 76, was undocked at *Plymouth* on the 29th March, having undergone a thorough repair.

The captain and Officers of his Majesty's late ship *Thetis* have presented to Mr. Jacob Geach, boatswain, a very elegant silver cup; and to *John Langley*, Captain of the Foretop, a handsome silver tobacco box, for their manly and intrepid conduct on the night of the 5th of December. The petty officers and seamen of the *Thetis* also presented a gold chain, call, and plate with an inscription expressive of their gratitude to Mr. Geach, for his exertions in saving the lives of the crew on the occasion.

The *Grand Cross* of the *Guelph* has been conferred by his Majesty, on *Admiral Sir William Hargood*, and that of *Knight Commander* of the same order, on *Capt. Usher*, and *George Seymour, C. B.*

The following order has issued from the *Royal Marine Office*, to the several commandants of that corps:—

Royal Marine Office, 31st March, 1831.

Brigade Order.—His Majesty having been pleased to appoint Major-General Sir James Cockburn, Bart. to be Inspector-General, and to command the brigade of Royal Marines, the Major-General cannot assume the command without expressing to the several divisions of Marines and Royal Marine Artillery the gratification which he feels in having his connexion thus strengthened and continued with a corps of whose merit he has already had such long and satisfactory experience. He begs they will collectively and individually be assured of his earnest disposition, upon all occasions, to promote their interest and welfare, and to direct the discharge of the high duties with which his Majesty has been graciously pleased to honour him, to the maintenance and extension of the honourable fame which the corps of Royal Marines have so invariably and eminently established.

By command of the Major-General,
JOHN WRIGHT, Ass. Adjt.-General.
To the Commandants.

Sir James Graham, Bart. Admirals Sir Thomas Hardy and Dundas, accompanied by the Hon. Capt. Elliot, embarked at Woolwich on the 4th ult. to inspect the dock-yard at Sheerness.

H. M. S. Dublin was commissioned at Plymouth on the 15th ult. by Lieut. Mure, for Capt. Henry Hope. Capt. Giles, Second Lieut. William F. Hopkins, R. M. and forty marines, embarked on board this ship on the 19th.

The Pearl, 18, Commander Blake, was paid off at Portsmouth on the 16th ult. and re-commissioned by Commander Broughton.

The Brisk gun brig was commissioned at Portsmouth on the 18th ult. by Lieut. E. H. Butterfield, late First Lieut. of the Primrose.

H. M. S. Stag was commissioned at Plymouth on the 18th ult. by Lieut. F. D. Hastings, for the broad pendant of Commodore Sir Thomas Troubridge, Bart. She is to relieve the Semiramis, Rear-Admiral the Hon. Sir C. Paget, at Cork.

H. M. S. Pylades, 18, Commander P. D. H. Hay, ran on the rocks at Roona Point, about five miles beyond Old Head, about nine o'clock on the morning of the 13th of April, and, by the last accounts, was high and dry upon the reef, lying upon her side.

The Trinculo, 18, Commander S. Price, was paid off at Plymouth on the 20th ult..

H. M. S. Rattlesnake, 28, Capt. Graham, and the Manly, 10, Lieut. Wheatley, were paid off at Portsmouth on the 20th ult. The former was recommissioned by Capt. Graham, and taken into dock on the 22nd, and the latter placed in Ordinary.

Captain Thomas Huskisson is appointed to superintend the lower school in Greenwich Hospital, in the room of the late Captain Donald McLeod; and it is understood that the vacancy as Captain of that establishment, vacant by the death of the latter officer, will not be filled up.

The Lords of the Admiralty have taken under their patronage the appointment of all surgeons and assistant-surgeons to His Majesty's ships.

The Queen has appointed Captain Pechell, R.N. to be one of her Majesty's Equerries. Vice Capt. T. Usher, C. B. resigned.

PRIZE MONEY.

PRIZES ADVERTISED FOR PAYMENT IN THE LONDON GAZETTES, AS REPORTED TO THE TREASURER OF THE NAVY, DOWN TO THE 19TH OF MARCH 1831.

WAR OF 1793.

Montague, for L'Aviso La Dorade, capt. 3rd June 1799.—Pay. 27th Jan. 1831.—Agt. John Copland, 23, Surrey-street, Strand.

Phoenix, for Purissima Concepcion, capt. 9th March 1800.—Pay. 6th Jan. 1831.—Agt. John Hinxman, 72, Great Russell-street, Bloomsbury.

Ditto, for Le Revanche, capt. 17th June 1800.—Pay. 6th Jan. 1831.—Agt. John Hinxman, 72, Great Russell-street, Bloomsbury.

WAR OF 1803.

Active, for Three Gun-Boats, capt. 27th July 1811.—Pay. 27th Jan. 1831.—Agt. John Copland, 23, Surrey-street, Strand.

Ditto, for Madona D'Idra, capt. 1st April 1807.—Pay. 27th Jan. 1831.—Agt. J. Dufaur, 13, Clement's-Inn.

Gleaner, (Hired Armed Ketch), for Adelaide, capt. 27th March 1813.—Pay. 24th Jan. 1831.—Agt. J. Woodhead, 1, James-street, Adelphi.

Grasshopper, for Kexes, capt. 27th June 1828; and Il Firme, capt. 22nd Nov. 1828.—Pay. 2nd March 1831.—Agt. John Copland, 23, Surrey-street, Strand.

Moselle, for Ynez, capt. 11th April 1808.—Pay. 27th Dec. 1830.—Agt.

Mandes and Co. Great George-street, Westminster.

Monkey, for Midas, capt. 27th June 1829; and Josefa, capt. 7th April 1829.—Pay. 21st Feb. 1831.—Agt. John Copland, 23, Surrey-street, Strand.

Nimble, for Gallito, capt. 16th Nov. 1829.—Pay. 21st Feb. 1831.—Agt. John Copland, 23, Surrey-street, Strand.

Plumper, for Ceres, capt. 6th Aug. 1829.—Pay. 6th Jan. 1831.—Agt. John Hinxman, 72, Great Russell-street, Bloomsbury.

Redwing, for Anna and Teresa, capt. 6th and 11th Oct. 1825.—Pay. 9th April 1831.—Agt. F. M. Ommanney, 22, Norfolk-street, Strand.

Salsette, for La Comete, capt. 21st April 1812.—Pay. 15th March 1831.—Agts. Cooke, Halford, and Son, 41, Norfolk-street, Strand.

Topaze, for La Centinelle, capt. 24th Aug. 1810.—Pay. 15th March 1831.—Agts. Cooke, Halford, and Son, 41, Norfolk-street, Strand.

PRIZES ADJUDICATED IN THE HIGH COURT OF ADMIRALTY, AS REPORTED TO THE TREASURER OF THE NAVY, DOWN TO THE 19TH OF MARCH 1831.

Castor, for Le Minuit, capt. 22nd Jan. 1814.—Cond. 21st Jan. 1831. Head Money pronounced for 25 men.

Fairy, for Na Sa del Pont St. Bonaventura, capt. 11th Feb. 1799.—Cond. 12th Nov. 1830. Head Money pronounced for 40 men.

Laura (Cutter), for Rhone, capt. 4th Aug. 1807.—Cond. 12th Nov. 1830. Head Money pronounced for 26 men.

Magicienne, for Adeline, capt. 14th March 1814.—Cond. 2nd March 1831. Head Money pronounced for 31 men.

ABSTRACT OF PARLIAMENTARY PROCEEDINGS CONNECTED WITH THE NAVY AND ARMY.

HOUSE OF COMMONS, APRIL 13.

Ordnance Estimates.—Mr. Tennyson said, that the perusal of the printed estimates would preclude the necessity of his going at much length into the details. The sum to be expended this year was 1,714,999*l.* from which was to be deducted, for the value of stores, 296,182*l.* leaving only the sum of 1,418,817*l.* to be provided for. Last year the amount was 1,689,444*l.* so that between the estimates of the last and the present year, there was a difference of 270,827*l.* less charge on the

public. Deducting, however, the balance in hand, the actual reduction was 166,000*l.* Respecting the college at Sandhurst, he stated that Government contemplated some alterations. It was intended to admit pupils into the academy at Woolwich on their paying a certain sum. There was every disposition on the part of the Master-General of the Ordnance to pay as much attention to economy as possible: much had been done in that way by the late Government, and he hoped the present administration would receive credit for following the example of their predecessors. He then moved that a sum not exceeding 80,649*l.* be granted to His Majesty for salaries of the Master-General and principal officers and clerks of the Ordnance Departments at the Tower, Pall-Mall, and Dublin, for the year 1831.

Sir Henry Fane declared his satisfaction at the candid and honourable manner in which the hon. gentleman had expressed himself with respect to the conduct of the late Board of Ordnance under the head of economy.

Sir H. Hardinge thought the present arrangement of the estimates a very good one upon the whole, and was disposed to admit that some of the alterations were likely to be beneficial. He contended, however, that the real saving to the public on the present estimate, would be only about 3000*l.* and that all the rest of the diminution of charge arose from the postponement of works to be performed, or from allowances on account of balances of stores. He did not approve of the abolition of the office of Lieutenant-General of the Ordnance; and argued, that with respect to the Marines and the Navy Board, the present Government had pursued a course similar to that which they censured their predecessors for adopting in reference to the Ordnance. So much for the difference between the professions of gentlemen when out of office, and their practice when in the possession of power.

Mr. Tennyson denied that the right honourable and gallant member was correct in describing the saving as being only 3000*l.*—the right honourable gentleman might just as well have asserted that it did not exceed 3*l.* He (Mr. Tennyson) thought that the details into which he had before entered, must have satisfied the committee that the actual saving would be, stating it at the lowest, 100,000*l.* if not 166,000*l.*

Sir H. Hardinge contended that a diminution, on account of money not drawn for works, the progress of which was suspended, could not be considered as a real saving

of expenditure. With respect to the military schools, those establishments were all of a military nature, and if they were once let down, Ministers, he was sure, would not be able easily to raise them up again.

Sir H. Fane said, that 53,000*l.* was called for on account of repairs. Now he doubted the adequacy of that sum, because he understood that a most experienced and intelligent officer had stated, that there were at present, no less than 10,000 gun-carriages out of repair, and for which he could not answer. Situated as Europe was at present, this was a matter of most serious importance.

Mr. Hume censured the plan which Government had long adopted, of collecting large quantities of stores to perish and decay. Here it appeared, from the statement of the honourable baronet, that there were 10,000 rotten gun-carriages in store. The saving proposed in these estimates by His Majesty's Government were very trifling, but he trusted that they would be greater hereafter.

Sir H. Fane denied that he had spoken of rotten gun-carriages. He said it was reported that a most experienced officer had represented that there were 10,000 gun-carriages which were out of repair.

The Chancellor of the Exchequer contended, that a very considerable saving had been really effected in these estimates. He considered the not calling for a grant, on account of certain works, as a saving. Some of those works might hereafter be deemed unnecessary.

Sir H. Hardinge maintained that a great saving had been made under the Duke of Wellington. In the salaries of civil officers alone, it was 47,000*l.* The number of stations now was one or two more than in 1792, though we had now seven or eight powder-magazines included amongst them.

Mr. Maberly said, that the late Government had acted in the teeth of the report of the Committee of Finance, which had recommended the abolition of the office of Lieutenant General of the Ordnance. The present Government immediately abolished the office, and yet it was admitted the service was as well carried on without that office.

Sir H. Hardinge said the recommendation of the committee was contrary to the evidence given before them.

Sir G. Warrender admitted and praised the economy of the present Government, and said that the conduct of the late administration, in resisting reductions which had been recommended to them, brought

about that measure of reform which he so much deprecated.

Mr. Tennyson said that the present Government had not begun the ordnance estimates, they had only reviewed them. When they should have an opportunity of forming estimates of their own, a greater reduction might be expected.

The motion was then agreed to.

The other items were agreed to without observation.

APRIL 20TH.

Ordnance Estimates.—Mr. Tennyson moved various items of the ordnance estimates, which were agreed to without any observation. At length

Mr. Hume said that he would not oppose any of the items of these estimates, because, after the vote of the previous night on the Reform Bill, he was anxious to assist Ministers in getting through the necessary business, in order that a dissolution might take place. Running neck and neck as parties were in the house, it was delusion to suppose that the Reform Bill could pass in the present Parliament. For these reasons he gave his hearty concurrence to the estimates proposed by Government for the first time in his life.

Colonel Trench observed, that the last Administration had effected a reduction of 47,000*l.* per annum in this department, whilst the present Administration had retrenched only to the extent of 4,000*l.* or 5,000*l.*

Mr. Tennyson said that he hoped to be able to effect a much greater reduction next year.

The remaining items were agreed to, and the House resumed.

PROMOTIONS & APPOINTMENTS.

NAVY.

PROMOTIONS.

COMMANDERS—W. Gibbons (retired); W. Gilchrist (retired).

LIEUTENANTS—Mr. J. G. Dick; J. H. Windham.

MASTER—W. E. King.

SURGEON—Dobbs.

APPOINTMENTS.

CAPTAINS—Henry Hope, to the Dublin; David Duda, to the Curaçoa; John Clavel, to the Ordinary at Sheerness.

COMMANDERS—W. Broughton, to the Pearl; John Sheppard (b), to the Donegal; William Smith, to the Philomel; — Powney, to the Pre-

ventive Service, Aldborough, Norfolk; Robert McCoy, to ditto, Poole; Reuben Paine, to ditto; — Douglas to ditto; J. Pallen, to ditto; W. Allen, to ditto; — Heiland, to ditto; — Hutchinson, Inspector of the Coast Guard Service at Plymouth; — Ferris, ditto, at the Pendernis station; Thomas Mansel and Richard Barton, to the Preventive Service on the Coast of Kent.

LIEUTENANTS—J. F. Stirling (1824) Flag Lieut. to Vice-Admiral Sir Henry Hotham, the Commander-in-Chief for the Mediterranean; G. Caswell, from the Asia to the Pallas; C. Walcott, to the Asia; N. W. Chambers, to the Prince Regent; J. R. R. Lilburn, to the Savage; T. Henderson, John Wise, and John Steane, to the Preventive Service; T. Renon, to the Wickham; W. Prowse, to the Rose; R. Butcher, to the Tartar; C. Byne, to the Sprightly; G. Hales, to the Eagle Revenue Cruiser; W. H. H. Carey, to the Barham; Hon. C. B. Carey, to the Dublin; A. C. Duncan, to the Prince Regent; R. B. Beachy (sup.) to the Belvidera, to join the Blonde; Edward Dixon, to the Curaçoa; T. L. Massie, to the Prince Regent; J. P. Pritchard, to the Donegal; W. Sturgess, to the Ordinary at Sheerness; George Williams, to the Ordinary at Chatham; E. Medley and John Goldie, to the Ordinary at Sheerness; G. Goldfinch, to the Pearl; J. P. Baker, to the Coast Guard Service; E. H. Butterfield, from the Pallas to the Briak; F. D. Hastings and William O'Brien Hoare, to the Stag; T. E. Smith and W. J. Williams, of the Trincolo, to the Druid; James Mure, of the Caledonia, to the Dublin; B. Watson, to the Caledonia, vice Mure. The following Lieutenants are appointed to the Preventive Service on the Sussex Coast, viz.:—F. Phillips, A. Kortright, T. M. Williams, G. Howes, James Pratt, W. Maxwell, T. Eversfield, E. C. Earle, J. M. Motley, R. Joachim, W. Winniett, J. Rawstone, H. J. Carr, W. A. Ferrar, A. M'Tavish, J. Prattent, H. Courtnay, J. Conjuist, J. O'Reilly, G. J. Smyth, J. G. Raymond, F. Hire, J. J. Nicholls, R. J. Woolver, J. Hills, F. Collins, H. Leeworthy, S. Connor, T. Pennington, G. Palmer, C. M. M. Wright, E. Franklin, C. A. Petch, J. Bowden, C. Servaute, J. W. Crispe, W. Stone, J. W. Tomlinson, H. D. Foster, W. Ball, G. Mason, J. Stewart, T. Carey, and G. F. Walker.

MASTERS—W. E. King, to the Victor; W. Aykhone, to the Dublin; G. B. Hoffmalster, to the Curaçoa; John Thomas, to the Stag.

SURGEONS—J. Isatt, to the Barham; — St. Irvine, M.D., to the St. Vincent; Thomas Miller, to the Dublin; John Drummond, to the Curaçoa; — Dobbs, to the Lightning.

ASSISTANT-SURGEONS—Charles Smith and John Christie, to the Dublin; H. Arnot, to the Messenger, Steamer; — Elliott, to the Prince Regent; William Macauley, to the Sylvia; David Jardine, to the Stag.

PURSEURS—T. Giles, to the Orestes; John Chimmo, to the Dublin; T. Jessopp and Thomas Stones, to the Ordinary at Sheerness; John Richards, to the Ordinary at Portsmouth; W. Williams, to the Curaçoa; James Wise, to the Stag.

CHAPLAINS—The Rev. James Surridge, to the Druid; the Rev. John Baker, to the Dublin; the

Rev. T. Ferris, to the Astrea; the Rev. John Marshall, to the Barham.

ROYAL MARINES.

PROMOTIONS AND APPOINTMENTS.

The following removals and exchanges in the Royal Marines have taken place, consequent on the promotion in that corps:—

CAPTAINS—J. G. Richardson, re-appointed to Woolwich on his promotion; Charles Morgan, to Plymouth, on his promotion; J. Husband, appointed to Chatham Division on promotion.

FIRST-LIEUTENANTS—Ralph Carr, to Chatham on his promotion, vice F. Hamilton, removed to the Plymouth Division, in the room of First-Lieut. Henry Savage, (late of the Royal Marine Artillery,) whose appointment there has been cancelled in favour of the Woolwich Division; Edmund Nepean, of the Portsmouth Division of Royal Marines, to the Plymouth Division, vice Charles Robinson Miller, whose appointment to the Plymouth Division from the Royal Marine Artillery has been cancelled in favour of Portsmouth Division; — Farrant, R. M. A. to the Excellent.

SECOND-LIEUTENANT—Thomas Fraser, to the Wallesey.

ARMY.

WAR OFFICE, MARCH 12.

13th Regt. Light Drs.—Lieut. Thomas Earle Welby, from 26th Foot, to be Lieut. vice Neville, who exc.

3rd Regt. Foot Gds.—Ens. and Lieut. Beresford B. M'Mahon, to be Lieut. and Capt. by p. vice Hood, who ret.; Gailford James Hillier Onalow, gent. to be Ens. and Lieut. by p. vice M'Mahon.

1st Regt. Foot.—Capt. Charles Chidley Cootie, from 49th Foot, to be Capt. vice Pasley, who exc.

3rd Ditto.—Eric Mackay Clarke, gent. to be Ens. without p. vice Ludbey, who res.

13th Ditto.—Ens. Hamlet Wade, to be Lieut. without p. vice Chambre, dec.

To be Ensigns.—Ens. Henry Thomas Hutchins, from 14th Foot, vice Spread, who exc.; Thomas Sewell, gent. vice White, whose app. has not taken place; George King, gent. vice Wade, prom.

14th Ditto.—Ens. Robert Deane Spread, from 13th Foot, to be Ens. vice Hutchins, who exc.

16th Ditto.—To be Lieuts. without p.—Ens. Francis Fairtlough, vice O'Dwyer, dec.; Ens. John Bruce, vice Whitaker, who ret.

To be Ensigns without p.—Sir William Ogilvie, Bart. vice Urquhart, dec.; William Robert Lyon Bennett, gent. vice Bruce.

26th Ditto.—Lieut. Parke Percy Neville, from 13th Light Drs. to be Lieut. vice Welby, who exc.

31st Ditto.—Ens. Thomas Pender, to be Lieut. without p. vice Booth, dec.; Patrick Thomas Ramsay White, gent. to be Ens. vice Pender.

33rd Ditto.—Ens. George Augustus Vernon Graham, to be Lieut. by p. vice Paterson, prom.

35th Ditto.—Major George Teulon, to be Lieut. Col. by p. vice Macdonald, who ret.; Capt. Henry Semple, to be Major, by p. vice Teulon.

40th Foot.—John Stewart Wood, gent. to be Ens. without p. vice Alsop, dec.

41st Ditto.—Lieut. Percival Browne, to be Capt. vice Dawson, dec.

To be Lieuts. without p.—Ens. William Morris, vice Boulbee, dec.; Ens. Amelius Fry, vice Smith, dec.; Ens. William May, vice Browne, prom.

To be Ensigns, without p.—John Lawrie, gent. vice Morris; George Montizambert, gent. vice Fry; Robert Butler, gent. vice May.

To be Surgeon.—Staff-Surg. Alexander Hamilton, M.D. from h. p. to be Surg. vice Thomas Montgomery Perrott, who exc.

44th Ditto.—Lieut. William Boxall Scott, to be Capt. without p. vice Andrews, dec.

48th Ditto.—William George White, gent. to be Ens. without p. vice Campbell, app. to 49th Foot.

49th Ditto.—To be Captains.—Capt. Gilbert Pasley, from 1st Foot, vice Coote, who exc.; Lieut. William Pitman, from 59th Foot, without p. vice Leith, dec.

To be Lieuts. without p.—Ens. John Leslie Dennis, vice Fleming, dec.; Ens. John Malcolm, vice Mathew, dec.

To be Ensigns, without p.—Ens. Colin Campbell, from 48th Foot, vice Dennis; Henry Rainey, gent. vice Malcolm.

57th Ditto.—Major Humphrey Robert Hartley, to be Lieut.-Col. by p. vice Shadforth, who ret.; Capt. Philip Aubin, to be Major, by p. vice Hartley; Lieut. Thomas Shadforth, to be Capt. by p. vice Aubin; Ens. William Trauter, to be Lieut. by p. vice Shadforth.

59th Ditto.—Gent. Cadet Adam John Laing Peebles, from Rl. Mil. Col. to be Ens. without p.

60th Ditto.—Capt. Joseph Clavell Sladden Slyfield, to be Major, by p. vice Macpherson, who ret.; Lieut. Francis Marlton, to be Capt. by p. vice Slyfield; Sec.-Lieut. Charles Orgell Leman, to be First-Lieut. by p. vice Marlton; Richard Byrd Levett, gent. to be Sec.-Lieut. by p. vice Leman.

61st Ditto.—Ens. Henry Vicars, to be Lieut. by p. vice Heyland, prom.; Charles Frederick Mayne, gent. to be Ens. by p. vice Vicars.

65th Ditto.—Quar.-mast. James Elliott, from h. p. 43rd Foot, to be Quar.-mast. vice Coleman, ret. with a com. allow.

82nd Ditto.—Capt. Edward Grant Stokes, from h. p. to be Capt. vice Charles Mortimer, who exc.

87th Ditto.—Ass.-Surg. James Walsh, from 89th Foot, to be Ass.-Surg.

90th Ditto.—Bellingham George Fenton Graham, gent. to be Ens. by p. vice Hobart, who ret. 2nd West India Regt.—Robert Hunter, gent. to be Ens. without p. vice Crompton, dec.

Unattached.—Lieut. John Royley Heyland, from 61st Foot, to be Capt. of Inf. by p.

Memoranda.—The Christian names of Ens. Elliot, of 79th Foot, are Edmund James, and not Edmund John, as formerly stated.

Capt. Edward Powell, upon h. p. unat. has been allowed to retire from the service, by the sale of an unat. com.

The app. of Brevet Lieut.-Col. Robert Jones, from h. p. 1st Gar. Bat. to be Major in the 69th Foot, as stated in the Gazette of the 5th inst. has not taken place.

ST. JAMES'S PALACE, MARCH 23.

The King was this day pleased to confer the honour of Knighthood upon Capt. George Francis Seymour, of the Royal Navy, Knight Com. of the Royal Hanoverian Guelphic Order.

OFFICE OF THE MASTER OF THE HORSE TO THE QUEEN, MARCH 24.

The Queen has been pleased to appoint Capt. the Hon. S. Hay, Royal Fusiliers, to be one of Her Majesty's Equerries, vice Lieut.-Col. Fox, app. to the King's Household.

WAR-OFFICE, MARCH 24.

Memorandum.—His Majesty has been pleased to nominate Lieut.-Col. Thomas Lord Graitham, of the Yorkshire Hussar Yeomanry Cavalry, and Lieut.-Col. Edward Baker, of the Royal Wiltshire Yeomanry Cavalry, to be His Majesty's Aides-de-Camp for the service of his Yeomanry Cavalry.

MARCH 29.

Memorandum.—The h. p. of the under-mentioned officers has been cancelled from the 29th inst. inclusive, upon their receiving a commuted allowance for their commissions:—

Ens. Dudley Costello, h. p. unat.; Ens. William Wade Leslie, h. p. 59th Foot; Ass.-Surg. Roderick Macleod, h. p. 100th Foot; Ens. James Birney, h. p. 49th Foot; Ass.-Surg. Thomas Howell, h. p. Hosp. Staff; Lieut. Richard Gregory, h. p. 49th Foot; Lieut. Edward Lewis, h. p. unat.; Ens. Thomas Woodroffe Craig, h. p. 35th Foot; Ens. James Atkinson, h. p. unat.; Lieut. Jonathan Warner, late of the New South Wales Vet. Coms.; Lieut. Maurice FitzGerald, h. p. unat.; Ens. Thomas Knox Holmes, h. p. unat.; Surg. James George Playfair, h. p. Hosp. Staff; Lieut. Elliot Armstrong, h. p. 6th Drs.; Ens. Hercules Henry Slade, h. p. 43rd Foot; Lieut. William Warren, h. p. 37th Foot; Lieut. John Currie, h. p. 60th Foot; Lieut. Arthur Gambell Lewis, h. p. 68th Foot; Lieut. John Sankey Kelly, h. p. 4th Foot; Lieut. Alexander Macfarlane, h. p. 57th Foot; Lieut. Charles Irwin, h. p. Rl. Wag. Train; Lieut. Charles de Merwede, h. p. 2nd Light Inf. Bat. King's Ger. Leg.; Ass.-Surg. Robert Moorhead, h. p. 23rd Light Drs.; Ass.-Surg. John Nicholls Ashwood, h. p. 28th Foot; Ens. Frederick de Rönne, h. p. 3rd Line Bat. King's Ger. Leg.; Lieut. Alfred William Honne, h. p. 1st Foot; Ens. William Constantine, h. p. 8th Foot; Ass.-Surg. David Browne, h. p. 1st West India Regt.; Lieut. Robert Henry Dwyer, h. p. unat.; Lieut. Hon. Edmund Sexton Pery, h. p. 7th Light Drs.; Cornet James Sparrow, h. p. 17th Light Drs.; Ens. and Lieut. Sir Thomas Emsley Croft, Bart. h. p. 1st Foot Gds.; Lieut. John Francis Sabin L'Ecolier, h. p. Bourbon Regt.; Ass.-Surg. William Moffatt, h. p. 48th Foot; Lieut. Robert Stephenson Amiel, h. p. 25th Foot; Ens. Robert Blake, h. p. 4th West India Regt.; Lieut. Robert Dering, h. p. Rl. York Rangers; Ens. John Carysfort Proby, h. p. 24th Foot; Staff-Surg. James Beresford, h. p. Hosp.-Staff; Ens. Justin De Courcy, h. p. 2nd Greek Light Inf.; Ens. Sir George Rich, h. p. 5th Gar. Bat.; Lieut. John Canny, h. p. 30th Foot; Ens. George Arundel Hill, h. p. 27th Foot.

APRIL 1.

OFFICE OF THE MASTER OF THE HORSE
TO THE KING, MARCH 24.

The King has been pleased to appoint Lieut.-Col. Fox, to be one of His Majesty's Equerries in the room of the Hon. J. Kennedy Erskine, dec.

WHITEHALL, APRIL 4.

The King has been pleased to constitute and appoint Sir Henry Brook Parnell, Bart. to be His Majesty's Sec.-at-War.

WAR OFFICE, APRIL 4.

2nd Regt. Dr. Gds.—Lieut. Frederick Charles Griffiths, to be Capt. by p. vice Davies, who ret.; Cornet William Brandling, to be Lieut. by p. vice Griffiths; Richard Dann, gent. to be Cornet, by p. vice Brandling.

2nd Regt. Drs.—Cornet St. Vincent William Ricketts, to be Lieut. by p. vice Craufurd, prom.

4th Regt. Light Drs.—Ass.-Surg. John Graves, from 38th Foot, to be Ass.-Surg. vice Francis George Walbram, who ret upon h. p. 48th Foot.

9th Ditto.—Cornet and Adj. Robert Cooke, to have the rank of Lieut.

17th Ditto.—Frederick James Parry, gent. to be Cor. by p. vice Walker, who ret.

12th Regt. Foot.—Lieut. Henry Yarburgh Gold, to be Capt. by p. vice Prideaux, prom.; Ens. Frederick Bell, to be Lieut. by p. vice Gold; James Lloyd Phillips, gent. to be Ens. by p. vice Bell.

25th Ditto.—Gent. Cadet Charles R. Knight, from Rl. Mil. Col. to be Ens. without p. vice Lomax, who res.

35th Ditto.—Ens. John Gordon, to be Lieut. by p. vice Best, who ret.; Ens. Henry Edward Renwick, from h. p. 73rd Foot, to be Ens. without p.; James Fraser, gent. to be Ens. by p. vice Gordon.

38th Ditto.—Ass.-Surg. James Robertson, from h. p. 45th Foot, to be Ass.-Surg. vice Greaves, app. 4th Light Drs.

39th Ditto.—Gent. Cadet Marmaduke George Nixon, from Rl. Mil. Col. to be Ens. without p.

49th Ditto.—Staff Ass.-Surg. John Archibald, to be Ass.-Surg. vice John Loftus Hartwell, whose app. has not taken place.

43rd Ditto.—Lieut. the Hon. William Sydney Clements, to be Capt. by p. vice Wrottesley, prom.; Lieut. the Hon. Augustus Almerie Spencer, to be Capt. by p. vice Harris, who ret.; Ens. William Frederick Campbell, to be Lieut. by p. vice Clements; Ens. Jonathan Alderson, to be Lieut. by p. vice Spencer; Ens. Hon. Henry Cavendish Grey, from 90th Foot, to be Ens. vice Campbell; William Dixwell Oxenden, gent. to be Ens. by p. vice Alderson.

45th Ditto.—Lieut. William Henry Butler, to be Capt. without p. vice Archer, prom.

53th Ditto.—Ens. John Horner, to be Lieut. by p. vice Logan, prom.; Ens. Thomas Ancrem Heriot, to be Lieut. by p. vice Palmer, prom.; Thomas De Haviland, gent. to be Ens. by p. vice Horner; George Greene, gent. to be Ens. by p. vice Heriot.

60th Ditto.—Brev. Lieut.-Col. Alexander Macpherson, from h. p. 59th Foot, to be Major, vice Shee, prom.

U. S. JOURN. NO. 30. MAY 1831.

62nd Foot.—Ens. Henry Cooper, to be Lieut. by p. vice Baynes, who ret.; Henry Jackson, gent. to be Ens. by p. vice Cooper.

60th Ditto.—George Longworth Dames, gent. to be Ens. by p. vice Dickinson, who ret.

69th Ditto.—Brevet Lieut.-Col. Robert Johns, from h. p. 1st Gar. Bat. to be Major, vice Lord Edward Hay, prom.

79th Ditto.—Lieut. Andrew Brown, to be Capt. by p. vice Manle, who ret.; Ens. Thomas Isham, to be Lieut. by p. vice Brown; Edmund John Elliott, gent. to be Ens. by p. vice Isham.

83rd Ditto.—Lieut. Henry Francis Ainslie, to be Capt. by p. vice Renwick, who ret.; Ens. Charles Troubridge Egerton, to be Lieut. by p. vice Ainslie; Henry Lloyd, gent. to be Ens. by p. vice Egerton.

85th Ditto.—Lieut. George Brockman, to be Capt. by p. vice Hopwood, who ret.; Ens. Miles Charles Seton, to be Lieut. by p. vice Brockman; George Cochrane Dickson, gent. to be Ens. by p. vice Seton.

90th Ditto. Lord Charles Lennox Kerr, to be Ens. by p. vice Grey, app. 43rd Foot.

Ceylon Regt.—Lieut. John Hewitt, from h. p. of Dillon's Regt. to be Lieut. vice Keogh, prom.

Unattached.—To be Lieut.-Col. of Inf. by p.—Major Charles Shee, from 60th Foot.

To be Majors of Inf. by p.—Capt. Edmund Sanderson Prideaux, from 12th Foot; Capt. Charles Alexander Wrottesley, from 43rd Foot.

To be Major of Inf. without p.—Brevet Major Edward Caulfield Archer, from 45th Foot.

To be Capt. of Inf. by p.—Lieut. Robert Greagan Craufurd, from 2nd Drs.; Lieut. John Palmer, from 55th Foot; Lieut. James Paterson, from 33rd Foot; Lieut. Robert Logan, from 55th Foot.

Brevet.—To be Majors in the Army.—Capt. Walter Sweetman, Rl. New. Vet. Coms.; Capt. Anthony Alexander O'Reilly, Brig.-Major to the Forces; Capt. Denis Mahon, 4th Foot.

Memoranda.—The exchange between Ass.-Surg. Collis, of 15th Foot; and Ass.-Surg. Caldwell, on h. p. 31st Foot, was dated 25th September 1830, and net the 9th of July 1830, as formerly stated.

The under-mentioned officers have been allowed to retire from the service by the sale of unattached commissions:—

Majr.-Gen. William Stewart (1st), late 40th Foot; Capt. Malcolm Ross, h. p. unat.; Capt. John Fraser, h. p. 76th Foot; Brevet Lieut.-Col. the Duke of Richmond, Capt. h. p. 52nd Foot; Major William Stanhope Taylor, h. p. unat.; Capt. Robert Newland, h. p. Rl. Art.

LORD CHAMBERLAIN'S OFFICE, APRIL 18.

The Lord Chamberlain has appointed William Attree, Esq. Surgeon Extraordinary to His Majesty's Establishment at Brighton.

WAR OFFICE, APRIL 18.

4th Regt. Dr. Gds.—Major Henry Pratt, from h. p. to be Major, vice Thomas Hutton, who exc. rec. the diff.

13th Regt. Light Drs.—Lieut. James Boalth, from h. p. 22nd Light Drs. to be Lieut. vice Henry Elton, who exc.

x

5th Regt. Foot.—Lieut. Gilbert Champain, to be Capt. by p. vice Bent, who ret.; Ens. Beresford William Shawe, to be Lieut. by p. vice Champain; Samuel George Beamish, gent. to be Ens. by p. vice Shawe.

9th Ditto.—Ens. Stundholme Henry Metcalfe, to be Lieut. by p. vice Hilton, who ret.; Mordecai Glasse, gent. to be Ens. by p. vice Metcalfe.

37th Ditto.—Gent. Cadet John Richard Sheppard Wilson, from Rl. Mil. Col. to be Ens. by p. vice Ward, who ret.

70th Ditto.—Lieut. George B. Mathew, to be Capt. by p. vice Kirk, who ret.; Lieut. Frederick Becher Rocke, from h. p. 24th Light Drs. to be Lieut. vice Beath, whose app. has not taken place; Ens. John G. Corry, to be Lieut. by p. vice Mathew; William Matthew Bigge, gent. to be Ens. by p. vice Corry.

88th Ditto.—Serj.-Major Thomas Mills, to be Quar.-mast. vice Stewart, dec.

Rl. Staff Corps.—To be Majors, without p.—Capt. Thomas George Harriott; Capt. Henry Piers.

To be Capt. without p.—Lieut. William Dillon; Lieut. Edmund Martindale; Lieut. Thomas William Coleton; Lieut. Ernest Christian Wilford.

Memoranda.—The names of the Ens. app. to the 43rd Foot on the 5th inst. are Hon. Harry Cavendish Grey.

The name of the Ens. app. to the 55th Foot, on the 5th inst. is Thomas De Havilland, and not Thomas De Haviland.

The Christian names of Cornet Parry, of the 17th Light Drs. are Frederick John, and not Frederick James, as before stated.

His Majesty has been pleased to approve of the 5th Regt. Foot resuming the motto, "Quo fata vocant," formerly borne on its colours and appointments, in addition to its ancient badge of "St. George and the Dragon."

WAR OFFICE, APRIL 22.

31st Regt. Foot.—Gen. Sir Henry Warde, K.C.B. from 68th Foot, to be Col. vice Gen. the Earl of Mulgrave, dec.

68th Ditto.—Lieut.-Gen. Sir John Keane, K.C.B. from 94th Foot, to be Col. vice Sir Henry Warde, app. to the com. 31st Foot.

94th Ditto.—Major-Gen. Sir James Campbell, K.C.B. to be Col. vice Sir John Keane, app. to the com. 68th Foot.

Garrisons.—Gen. Sir George Don, G.C.B. to be Gov. of Scarborough Castle, vice the Earl of Mulgrave, dec.

DOWNING-STREET, APRIL 23.

The King has been pleased to appoint Colonel Stephen Remnant Chapman, C.B. to be Governor and Commander-in-Chief of the Bermudas or Somers Islands.

WAR-OFFICE, APRIL 26.

2nd Regt. of Life Gds.—Cor. John Eden Spalding, from 9th Light Drs. to be Cor. by p. vice Vansittart, who ret.

6th Regt. Dr. Gds.—Lieut. Joseph Deane Browne, to be Capt. by p. vice Porter, who ret.

Cor. Thomas Edward Taylor, to be Lieut. by p. vice Browne; Hon. Augustus George Frederick Jocelyn, to be Cor. by p. vice Taylor.

2nd Regt. of Drs.—Ens. Luchlan Macquaire, from 42nd Foot, to be Cor. by p. vice Ricketts, prom.

9th Regt. Light Drs.—Charles Joseph Trueman, gent. to be Cor. by p. vice Spalding, app. to the 2nd Regt. of Life Gds.

22nd Regt. Foot.—Lieut. David Rea Smith, to be Capt. by p. vice Jessopp, who ret.; Ens. Thomas Sydenham Conway, to be Lieut. by p. vice Smith; William George Austen, gent. to be Ens. by p. vice Conway.

35th Foot.—Lieut. Edward Davis, to be Capt. by p. vice Semple, prom.; Ens. John Hildebrand Oakes Moore, to be Lieut. by p. vice Davis.

To be Ensigns by p.—Charles Beamish, gent. vice Moore; Charles Milbank Peirse, gent. vice Alleyne, who ret.

42nd Ditto.—Andrew David Alston Steward, gent. to be Ens. by p. vice Macquaire, app. to 2nd Drs.

45th Ditto.—Ens. Magens Mello, to be Lieut. by p. vice Butler, prom.; Jocelyn Ingram Oakley, gent. to be Ens. by p. vice Mello.

46th Ditto.—Lieut. Donald Stuart, to be Capt. without p. vice Edwards, dec.; Ens. James Campbell, to be Lieut. vice Stuart.

49th Ditto.—Lieut. Thomas Scott Reignolds, to be Capt. by p. vice Ball, prom.; Ens. Allen Marshall, to be Lieut. by p. vice Reignolds; Henry Routh, gent. to be Ens. by p. vice Marshall.

56th Ditto.—Major Howell Harris Prichard, to be Lieut.-Col. by p. vice Barclay, who ret.; Capt. William Mitchell, to be Major, by p. vice Prichard; Lieut. Charles John Henry, to be Capt. by p. vice Mitchell; Ens. Francis Thomas Meech, to be Lieut. by p. vice Henry; Lewes Fraser, gent. to be Ens. by p. vice Meech.

69th Ditto.—Brevet Lieut.-Col. Robert Johns, from h. p. of 1st Gar. Bat. to be Major, vice Lord Edward Hay, prom.

71st Ditto.—Ens. Henry Tristram Beresford, to be Lieut. by p. vice Dalton, prom.; Richard Thomas William Lambart Brickenden, gent. to be Ens. by p. vice Beresford.

Rifle Brigade.—Staff-Ass.-Surg. William Pardey, to be Ass.-Surg. vice William Henry Fryer, who ret. on h. p.

Rl. African Colonial Corps.—Ens. William Shaw, to be Lieut. without p.; Ens. John Hodson Fearon, from h. p. to be Ens. vice Shaw.

Unatt.—Major Lord Edward Hay, from 69th Foot, to be Lieut.-Col. of Inf. by p.; Brev. Lieut.-Col. John William O'Donoghue, from 47th Foot, to be Lieut.-Col. of Inf. without p.; Capt. William Hawkins Ball, from 49th Foot, to be Major of Inf. by p.; Lieut. William Serjeantson Dalton, from 71st Foot, to be Capt. of Inf. by p.

Staff.—Richard Armstrong, gent. to be Adj. of a Recruiting District, with the rank of Lieut. vice Moss, dec.

Mem.—The undermentioned Officers have been allowed to ret. from the service, by the sale of nnat. coms.—Gen. John Lord Grewe; Capt. Alexander Roxburgh, h. p. Glengary Fencible Inf.

* * Lieut.-Gen. Hawker, although not yet gazetted, has been app. Col. of the 3rd Dr. Gds.

ANNALS OF THE BRITISH FLEET.

		Lords Commissioners of the Admiralty.	Principal Commanders-in-Chief.
1805.* War with France, Holland, and Spain.	First Lord—	Viscount Melville.†	Channel.—Adm. Hon. W. Cornwallis.
	— Lord	Barham.	Portsmouth.—Adm. Montagu.
	Sir Philip	Stephens, Bart.	Plymouth.—Vice-Admiral Young.
	James	Gambier.	Cork.—Adm. Lord Gardner.
	Sir John	Colpoys, K. B.	North Sea and } Adm. Lord Keith. Downs.
	Philip	Patton.	Halifax.—Vice Admiral Sir Andrew Mitchell.
	William	Dickinson, Jun.	East Indies.—{ V. Adm. P. Rainier, R. Adm. Sir E. Pellew, Rear-Admiral Sir Thos. Troubridge, Rear-Admiral Dacres.
	Sir Evan	Nepean, Bart.	Jamaica.—Adm. Sir J. T. Duckworth.
	Lord	Garlies from July vice Sir John Colpoys, K. B.	Mediterranean.—{ V. Adm. Lord Nelson, V. Adm. Sir R. Bickerton.

DISTRIBUTION OF THE BRITISH NAVAL FORCE IN EACH MONTH OF 1805.‡

Stations.	Number of Ships.											
	January.	February.	March.	April.	May.	June.	July.	August.	September.	October.	November.	December.
In Port and fitting	No. 149	No. 162	No. 148	No. 132	No. 143	No. 125	No. 120	No. 160	No. 173	No. 140	No. 140	No. 143
In the English and Irish Channels	154	141	146	154	147	192	178	173	157	157	154	135
In the Downs and North Seas	172	167	165	162	149	147	159	161	156	103	153	164
West Indies and on the passage	42	37	42	40	42	50	65	53	48	44	41	45
At Jamaica	34	40	39	39	42	51	37	43	38	32	38	33
In America and at Newfoundland	8	13	17	16	17	18	24	19	23	33	31	28
East Indies, and on the passage	28	28	31	32	33	34	28	31	33	32	35	39
Coast of Africa	3	3	4	4	4	4	3	4	—	—	2	0
Spain, Portugal, and Gibraltar	24	25	26	25	26	8	16	19	11	1	5	72
In the Mediterranean	36	41	44	41	45	40	26	22	26	55	77	29
With Sealed Orders	3	2	2	—	—	—	—	1	—	—	3	5
Hospital and Prison Ships	15	16	15	15	18	14	17	19	17	20	16	23
In pursuit of a French squadron	—	—	—	6	7	8	—	—	—	—	—	—
Secret Expedition	—	—	—	—	—	—	—	—	—	5	5	—
Guard Ships	14	14	16	12	11	11	9	11	8	14	14	13
Total Ships in Commission	682	694	695	678	684	702	682	706	690	698	710	735
Receiving Ships	12	15	15	17	16	15	18	12	15	20	16	17
Serviceable and repairing for Service	37	35	34	37	31	56	55	48	40	40	54	44
In Ordinary	112	110	108	101	91	71	66	62	63	71	70	84
Building	64	51	66	67	73	55	58	51	58	68	72	77
Grand Total	907	905	918	900	895	899	879	879	874	903	928	957

* For the year 1804, see p. 374, vol. 4.

† Resigned in April, in consequence of the charges preferred against him in the House of Commons, by Mr. Whitbread, on the 6th April, and the resolutions of the House thereupon.

‡ Exclusive of the hired armed vessels chiefly employed in protecting the coasting trade of Great Britain.

Number of ships of the line from 60 to 120 guns, ships from 44 to 50, frigates, sloops, &c. on the 1st of January and 1st of July, 1805.

January 1st 1805.					Stations of the British Navy in two months of 1805, viz:—	July 1st 1805.				
60 to 120 guns	44 to 50 guns	Frigates	Sloops, &c	Total.		Total.	Sloops, &c	Frigates.	44 to 50 guns	60 to 120 guns
No.	No.	No.	No.	No.		No.	No.	No.	No.	No.
17	7	31	94	149	In Port and fitting.	120	80	21	5	14
26	3	28	97	154	In the English and Irish Channels.	178	111	30	1	38
7	6	12	147	172	In the Downs and North Seas.	159	132	13	7	8
1	—	14	27	42	West India Islands, and on the passage.	65	29	19	—	17
3	—	11	20	34	At Jamaica.	37	25	10	—	2
—	1	5	2	8	In America and at Newfoundland.	24	16	6	2	—
8	3	8	9	28	East India Islands, and on the passage.	28	7	10	3	8
—	—	2	1	3	Coast of Africa.	3	1	2	—	—
15	—	3	6	24	Spain, Portugal, and Gibraltar.	16	5	4	—	7
11	—	14	11	36	In the Mediterranean.	26	12	13	—	1
—	—	1	2	3	With sealed Orders.	—	—	—	—	—
13	1	1	—	15	Hospital and Prison Ships.	17	—	1	1	15
—	—	—	—	—	In pursuit of a French Squadron.	—	—	—	—	—
—	—	—	—	—	Secret Expedition.	—	—	—	—	—
4	1	7	2	14	Guard Ships.	9	—	4	2	3
105	22	137	418	682	Total Ships in Commission.	682	418	132	21	111
5	3	4	—	12	Receiving Ships.	18	1	7	4	6
17	1	17	2	37	Serviceable and repairing for Service.	55	6	21	5	23
42	12	37	21	112	In Ordinary.	66	15	20	10	21
15	—	21	28	64	Building.	58	27	15	—	16
184	38	216	469	907	Grand Total.	879	467	195	40	177

State of the Ordinary at each Port, included in the above statement.										
21	1	16	5	43	Portsmouth.	39	5	15	2	17
19	14	13	3	39	Plymouth.	37	5	15	3	14
16	6	5	4	31	Chatham.	23	3	4	8	8
1	1	4	6	12	Sheerness.	10	4	3	1	2
7	4	20	5	36	River Thames.	30	5	11	5	9

ACTIONS AND OCCURRENCES AND CHRONOLOGICAL EVENTS OF THE BRITISH NAVY.

January — Mungo Park sailed from Portsmouth on his second expedition into the interior of Africa.*—11. Orders issued by Great Britain for making general reprisals against Spain.—18. Le Vimereux (French lugger), 15 guns, 60 men, captured by the Greyhound, 32, C. Elphinstone, in the Channel.—21. The Doris, P. Campbell, 36, B. 1795, struck in the night on a sunken rock, and destroyed, in Quiberon Bay, crew saved.—23. A French felucca, 1 gun, 1 swivel, 27 men, taken by the Peterell (sloop), 18, J. Lambert, Jamaica Station.—26. L'Elizabeth, French schooner, 4 guns, 34 men, taken by the Epervier (brig), 16, John Impey, Leeward Island Station. Flip, 18 men, (Dutch) taken by the Swan (hired cutter), Lieut. W. R. Wallace.—29. The Raven (brig), William Layman, 18, B. 1804, wrecked in Cadiz Bay, two of the crew lost. Deux Amis (French privateer) 6 guns, 40 men, taken by the King Fisher (sloop), 18, R. W. Crabb, Jun.—30. The London Docks opened.

February. The Arthur (formerly Venus) cutter, Lieut. R. Cooban, 6, hired, taken by a French squadron in the Mediterranean. A French squadron of three ships of the line, and some frigates, made an attack on the town of Rosseau, Dominica, and after a gallant defence by Gen. Prevost, the town capitulated, but in a few days the French abandoned their conquest.—See Military Annals.—4. The Arrow (sloop), of twenty-eight 32-pound carronades, and 125 men, Capt. R. B. Vincent,

* The plan of the expedition was that Park, with a detachment of soldiers, an adequate store of merchandize, and a few seamen and carpenters should construct vessels for the navigation of the Niger.

and the Acheron (bomb), of eight carronades, two bombs, and 67 men, A. Farquhar, having charge of convoy from Malta, bound to England, were captured by the French frigates *Hortense*, of 48 guns and 340 men, and *Incorruptible*, of 42 guns and 320 men, off Cape Caxine.* *El Fuerte de Gibraltar*, 4, Spanish, taken by the *Mercury*, D. P. Bouverie.—7. *Madame Ernouf* (French), 16 guns, 120 men, taken by *Le Curieux* (sloop), 16, G. E. B. Bettesworth, Leeward Island Station.—8. *Carmerara* (Spanish) schooner, 16 guns, taken by the *Lark* (sloop), 18, Frederick Langford, Bay of Senegal. *Orquillo*,† 18, (Spanish) taken by the *Peque*, 36, C. H. B. Ross, off the Havana.—13. The *Melampus*, 36, S. Pointz, captured near the Passage du Raz, two gun brigs, carrying two 24 and one 18-pounder each; and four luggers mounting one 18-pounder each. The *Rhoda* and *Faith* armed cutters, the latter commanded by Lieut. J. Nicholson, captured two luggers also of the same description. General Augereau (French), 14 guns, 86 men, taken by the *Topaze*, 38, W. T. Lake, Irish Channel.—14. *La Psyche*, 38, (French) taken by the *St. Fiorenzo*, 36, H. Lambert, East Indies, after a very spirited resistance of three hours and a half.—23. *Ville de Milan*,‡ 48, (French) taken by the *Leander*, 50, John Talbot, on the Halifax Station. The *Bouncer* (gun brig), Lieut. S. Bassan, 14, B. 1804, wrecked off Dieppe, and crew made prisoners.

March 1. *La Farina* (Spanish) schooner, 4 guns, 62 men, taken by the *Circe*, 32, J. Rose, off Oporto. *Imogene* (sloop), H. Vaughan, 18 Pr. P. 1804; foundered on her passage from Leeward Islands, crew saved. *Redbridge* (schooner), 8, B. 1804, lost at Jamaica, crew saved.—7. *Santa Rosalia Galandrina* (Spanish), 57 men, taken by the *Rein Deer*, 16, J. Fyffe, Jamaica Station. *El Intrepid*, corvette (Spanish), 14 guns, 66 men, taken by the *Immortalité*, 36, E. W. C. B. Owen, at sea.—10. Mr. Thomas Musgrave, Commander of the *Kitty*, private sloop of war, after an action of one hour and a half, captured the Spanish private ship of war, *Felicity*, of 20 guns and 170 men; one of the *Kitty's* men was killed and two dangerously wounded. This action was highly creditable to British valour, as not 20 of the *Kitty's* crew ever saw a gun fired before, and not twice that number were ever at sea before, leaving the *Downs* on the 3rd of the month.—16. *L'Intrepid* (schooner), 4 guns, 62 men, taken by the *Grenada* (schooner), 10, Lieut. John Barker, Leeward Island Station.—23. *Antelope* (Dutch), 5 guns, 54 men, taken by the *Stork* (sloop), 18, G. Le Geyte, Jamaica Station.

April 2. *Empereur* (French), 14 guns, 82 men, taken by the *Eagle*, 14, David Colby, Leeward Island Station.—3. *L'Elizabeth*, 10, (Spanish), taken by the *Bacchante*, 20, Charles Dashwood, off the Havana. Capt. Dashwood after this capture, having information that there were three French Privateers in the harbour of Mariel, determined to ront them. Lieuts. Oliver and Campbell volunteered their services, and were dispatched on the evening of the 5th in two boats; and as it was absolutely necessary to gain possession of a round tower, near 40 feet high, on the top of which were three long 24-pounders, with loop holes round its circumference for musketry, and well manned, they

* The noble defence made by this sloop and bomb-vessel, enabled thirty-one out of thirty-four merchantmen to escape. At a quarter past four A.M. the *Hortense*, after heaving, opened a fire of round and grape on the *Acheron*, which she returned with her starboard guns, then tacked and discharged her opposite ones. The *Arrow*, which had in the mean time bore up, raked the *Hortense*. Daylight showed to the British the force with which they had to contend. The *Arrow* made signals to the convoy, and hauled the wind, followed in close order by the *Acheron*. About five minutes after seven, being abreast of the *Arrow*, and within half-musket shot distance, the *Incorruptible* opened her broadside, and received that of the *Arrow* in return. In a few minutes more this frigate arrived up with, and began engaging the *Acheron*; and the *Hortense* having closed with the *Arrow*, the action then became general. From being exposed to the fire of both frigates, the *Arrow* became unmanageable, and in this state was warmly engaged with the *Incorruptible*. At length, having four of her guns dismounted, her rudder machinery disabled, her lower masts and yards badly wounded, several shot between wind and water, 13 of her crew killed, and 27 wounded, the colours were hauled down, after being engaged more than an hour. In twenty minutes after, the *Acheron*, who, on the *Arrow's* surrender, had made all sail to the southward, having also been much disabled in masts, sails, and rigging, struck her colours to the *Hortense*. Scarcely had the surviving crew been removed from the *Arrow*, than she sank; and the shattered state of the *Acheron* induced the captors to set her on fire. The French frigates had each about 300 troops, exclusive of their crews.

† Afterwards foundered, see October.

‡ The *Ville de Milan* had previously taken the *Cleopatra*, 32, Sir Robert Lawrie, after a long and most determined resistance, which latter was also retaken by the *Leander*. Sir Robert Lawrie did not surrender until he had so completely disabled his huge opponent, as to render both vessels (now French) an easy capture to the *Leander*, Capt. Talbot, one of the most promising young officers in the service, who, by this means, and scarcely firing a gun, had the option of commanding one of the finest frigates in the French Navy; but with that generous spirit, the characteristic of a brave officer, he deferred this material object to Sir Robert Lawrie, to whose spirit, bravery, and perseverance alone, he generously ascribed the double capture of the *Ville de Milan* and her prize the *Cleopatra*, as, if the Frenchman had not been so beaten, she certainly would not have proved so easy a prize. Sir Robert in his dispatch observed, that immediately after the surrender of the *Cleopatra*, "she became a perfect wreck, not a spar standing but the mizen-mast, the bowsprit, and other masts gone by the board, and I fully expected she would have foundered before both ships could get clear of each other."—"More gallantry and bravery could not have been displayed than by both officers and men of so young a ship's company, many being under twenty years of age, and only three marines who had joined that corps more than two weeks before they embarked."—Dispatch.

had to carry the fort previous to their entering the harbour, so as to secure a safe retreat. Lieut. Oliver being in the headmost boat, finding himself discovered, and as not a moment was to be lost at such a critical period, "most nobly advanced, without waiting for his friend, landed in the face of, and in opposition to, a most tremendous fire, without condescending to return the salutation, mounted the fort by a ladder, and fairly carried it by a coup-de-main."^{*} "Having been rejoined by Lieut. Campbell, he dashed on to attack the privateers, but found they had sailed the day previous on a cruise. He was therefore obliged to be content with taking possession of two schooners laden with sugar."—Dispatch.—4. La Hazard (French) schooner, 6 guns, 80 men, taken by the *Blanche*, 33, Zelludge, Jamaica Station.—6. Mr. Whitbread, in the House of Commons, brought forward charges against Lord Melville, for misapplication of the public money, when Treasurer of the Navy, and in consequence of the resolutions of the House, his Lordship† resigned the office of First Lord of the Admiralty.—8. La Desirée (French) schooner 14 guns, 71 men, taken by the *Barbadoes*, 23, Joseph Nurse, at sea.—9. French schooner, name unknown, 7, sunk by the *Graciense*, 14, T. B. Smith, Jamaica Station.—11. Treaty of Concert concluded between Great Britain and Russia against France: Austria, and Sweden, shortly after joined in the league.—12. L'Alert, (French) 4 guns, 32 men, taken by the *Inflexible*, 64, T. Bayley, at sea.—13. Capt. P. Carteret of the *Scorpion* brig, (18) in company with the *Providence*, (16) Capt. Rye, captured L'Honneur,§ Dutch schooner of 12 guns.—14. *Orestes*, 1 gun, 6 swivels, 36 men, and *Pylades*, same force, (both French) taken by the *Musquito* sloop, 16, S. Jackson, in the Channel.—15. *Conception*, (Spanish) felucca, 1 gun, 20 men, taken by the *Papillon*, 16, W. Woolsey, Savannah La Mar.—24. Seven Dutch Schuyts taken by Rear-Admiral Douglas's squadron off Cape Grienez.—27. General —, (French) taken by the *Renard* sloop, 14, Jeremiah Coghlan, Jamaica.—29. The Commons of England impeach Lord Melville at the Bar of the House for malversations during his tenure of the Office of Treasurer of the Navy.—30. La Perseverance (French) schooner, 5 guns, 84 men, taken by the *Seine*, 26, D. Atkins, Jamaica Station.

May 4. Le Temperebort (French) cutter, 4 guns, 35 men, taken by the *Uncorn*, 32, L. Hardyman.—6 and 7. La Renomée (French) 3 guns, 56 men, La Rencontre (French) 2 guns, 42 men, and *Venus* (French) 1 gun, 35 men, taken by the *Sandwich* cutter, 10, Lieut. Benardiney, Bahama Banks. Les Amis Reunis, (French) 2 guns, 38 men, taken by the *Victor* sloop, 16, Lieut. Bell, at the entrance of the Persian Gulf. Santa Rosa (Spanish) schooner, 3 guns, 57 men, taken by the *Hunter*, 16, S. H. Ingfield.—7. *Napoleon*, (Spanish) 20 guns, 108 men, taken by the *Topaze*, 36, W. J. Lake, at Sea.—8. Capt. C. Boyle, of the *Seahorse*, 38, having observed a Spanish convoy go into the anchorage of St. Pedro, to the eastward of Cape de Gatt, where they were protected by a fort, two armed schooners, and three gun and mortar launches, determined to attempt their destruction. The vessel of greatest consequence to get out was an ordnance brig, laden with 1170 quintals of powder, and various other stores for the gun boats on the coast, which was effected by Lieut. Downie, in a six-oared cutter, assisted by Mr. T. Napper, midshipman, in a four-oared boat. The *Seahorse* during the time kept up a well-directed fire on the fort, gun vessels, and convoy, and having sunk one of the gun-launches, and damaged and sunk several others of the convoy, night coming on, with light winds, the main-top gallant masts, sails, braces, and bowlines shot away by the fire of the gun-launches, she hauled off.—9. La Travela (Spanish) lugger, 3 guns, 40 men, taken by the *Millbrook*, schooner, 14, John C. Carpenter, Bayonne Islands.—11. *Damas*, (Spanish) 4 guns, 57 men, taken by the *Kingfisher*, sloop, 18, W. R. Cribb, off Cape St. Julah. *Hawke*, sloop, J. Tippet, 18, P. P. 1803, missing since May, supposed to have foundered in the channel. *Sea Gull*, brig, H. Burke, 18, B. 1795, and *Mary*, (hired) Lieut. T. S. Pacy, foundered in a cruise, with all the crews, time unknown. *Fly*, sloop, T. B. Pellew, 18, B. 1804, lost on the *Carysfort* Reef in the Gulf of Florida, crew saved.—12. *Cyane*,|| sloop, 18, Hon. G. Cadogan, B. 1796, (since *Cerf*) taken by the French frigates *Hortense* and *Hermione*, near Martinique. *Orestes*, sloop, T. Browne, 16, P. 1803, ran aground on a sand-bank near Gravelines, and afterwards burnt, to prevent capture; crew saved.—13. *Santa Anna* (Spanish) schooner, 5 guns, 108 men, taken by the *Peterell*, 18, J. Lamborn, off Cuba.—14. *Orestes* (French) 1 gun, 6 swivels, 34 men, taken by the *Inspector*, sloop, 16, E. J. Mitchell, Channel. Le Felix (Spanish) schooner, 6 guns, 42 men, taken by the *Bacchante*, 20, C. Dashwood, off the Havana.—16. *Justicia* (Spanish) schooner, 4 guns, 95 men, taken by the *Cyane*, 18, G. Cadogan.—17. Le Teazer (French) 7 guns, 51 men, taken by the *Osprey* sloop, 18, T. Clinch, Leeward Island Station.—20. El Fanix (Spanish) brig, 14 guns, 85 men, taken by *Topaze*, 36, W. T. Lake, at sea.

* "I wish to mark my admiration of the noble conduct of Lieut. Oliver in so gallantly attacking and carrying a fort which, with the men it contained, ought to have maintained its position against fifty times the number that were opposed; but nothing could withstand the prompt and manly steps taken by that officer and his gallant crew on this occasion."—Dispatch.

† On the 6th May, the Chancellor of the Exchequer acquainted the House that His Majesty had erased Lord Melville's name from the list of the Privy Council.

‡ Lord Melville was succeeded by Sir Charles Middleton, newly created a Baron of the Realm by the title of Lord Berham.

§ She had on board 1600 stand of arms, a complete set of clothing for that number of men, and a considerable quantity of warlike stores; she had besides, two field pieces, and two mortars, tents, &c. for troops. Jean Saint Paul, noted for his successful depredations on the British commerce, was a passenger on board of her.

|| Retaken by the *Princess Charlotte*, see October 5.

—26. San Felix El Socoro (Spanish) felucca, 1 gun, 40 men, taken by Racon, 18, E. Crofton, off Jamaica.—27. Conception (Spanish) felucca, 2 guns, 10 men, taken by Seine, 36, D. Atkins, off Puerto Rico.—28. De Zeeuo (Dutch) 13 men, taken by the Charger, brig, 14, J. A. Blow, North Sea Station.—31. French Privateer, name unknown, 1 gun, 25 men, taken by the Trinidad, schooner, 10, Lieut. Stout. La Desirée (French) felucca, 1 gun, 49 men, taken by the Heurenx, 29, G. Young-husband, West Indies.

June 2. Capt. Maitland, of the Loire (40), sent the launch and two cutters, under his first Lieutenant, Yeo, to bring out a small vessel which was discovered standing in the Bay of Camarinas, to the eastward of Cape Finisterre; from the intricacy of the passage, the boats did not get up till break of day, when they found two small privateers moored under a battery of 10 guns. Lieut. Yeo, undaunted by a circumstance so little expected, ordered the launch, commanded by Mr. Charles Clinch, Master's Mate, to hoard the smallest, whilst he with the two cutters attacked and carried the largest, the Esperanza, alias San Pedro, a felucca of 3 guns, 4 swivels, and 50 men; the launch had the same success, the fort opening a fire so ill-directed as to do little damage. Being perfectly calm, close under the guns of the enemy's battery, and no possibility of receiving assistance from the Loire, Lieut. Yeo was compelled to abandon the smallest vessel, a lugger of 2 guns, and 32 men, to secure the felucca.*—3. Capt. Maitland being informed there was a French Privateer of 26 guns fitting out at Elburos, appointed Lieut. Yeo to head the boarders, amounting, officers included, to 50 men. On hauling round the point of the road, a small battery of 2 guns opened a fire on the ship, which was returned; but perceiving it would be a considerable annoyance, Lieut. Yeo pushed on shore and spiked the guns. As the ship drew in, and more fully opened the bay, Capt. Maitland perceived a very large corvette, (the Constance of 26 ports) and a large brig (Le Belier of 20 ports), but neither of them firing, he concluded they had not their guns on board. The sole object of his attention therefore was the fort, which began a well-directed fire, every shot taking place on the hull. The fire was returned with great effect, and the fort would have been soon silenced, notwithstanding its spirited defence, had it not been completely embrasured. Lieut. Yeo soon put an end to their fire; after taking the small battery on the point, he perceived at the distance of a quarter of a mile a regular fort, ditched, and with a gate, which the enemy (not suspecting his landing) had neglected to secure, and which was firing upon the ship. Without waiting for orders he pushed forward, was the first in, and after a dreadful slaughter on the part of the enemy, the remainder surrendered, and the British colours were immediately hoisted.†—4. Constance (French) 26 guns, and Belier (French) brig, taken by Loire, 40, F. Maitland, Elburos. The British fleet under Admiral Lord Nelson, arrived at Barbadoes in pursuit of the Toulon French fleet, which after being joined by the Spanish fleet at Cadiz, had sailed from the latter place for the West Indies. His Lordship, on first learning that the Toulon fleet had put to sea, conjectured that the destination was Egypt, and he immediately sailed for Alexandria; but on his return, learning their true destination, and having hastily provisioned at Palermo, he again departed in pursuit.‡—5. Santa Leocadia (Spanish) 14 guns, 114 men, taken by the Helena, 18, Woodley Lozack, at sea.—10. L'Amitie, 14, (French) schooner, taken by the Blanche, 26, Z. Mudge, Jamaica Station.—11. The House of Commons agree to a criminal prosecution of Lord Viscount Melville.—13. Maria (Spanish) schooner, 14 guns, 60 men, taken by the Cambrian, 38, J. P. Beresford, at sea.—18. La Columbia, 16, (French) corvette, taken by the Endymion, 44, Hon. C. Paget.—21. Constance, (French) 10 guns, 75 men, taken by the Circe, 32, Jonas Rose.—25. Vallant (French) 80 guns, taken by the Loire, 40, F. Maitland, at sea. The House of Commons change their mode of proceeding, and resolve on impeaching Lord Melville.—26. Amotellan (Dutch) 12 guns, 60 men, taken by the Rosamond sloop, B. Walker, Home Station.

July 3. Matilda (French) schooner, 20 guns, 95 men, taken by the Cambrian, 38, J. P. Beresford, at sea.—7. Josefina, (French,) 2 guns, 35 men, taken by the Ramilies, 74, F. Peckmore, and Illustrations, 74, W. Shield.—10. La Hirondelle (French) brig, 16 guns, 90 men, taken by the Venus, 32, H. Malson, off Ireland.—11. In the House of Commons an address to His Majesty was resolved upon for copies of the correspondence between the British and French Governments relative " to the

* When the crew of the felucca were mustered, 19 out of 50 were missing, some of them had jumped overboard; but the greater part were killed by the pike, there being no weapon used but that and the sabre. The Loire's men, including officers, only amounted to 35 opposed to 80 Spaniards, with their vessels moored to the walls of a heavy battery.

† The British had 15 wounded; the Governor of the fort, and a Spanish gentleman who had volunteered, the second captain of the Constance, and nine others of the Spaniards, were killed; thirty, amongst whom were most of the officers of the Constance, were wounded. The enemy's force at the commencement of the action was a fort of 12 guns, 22 soldiers, several Spanish gentlemen and townsmen volunteers, and about 100 of the ships' company of the Constance. Capt. Maitland and his crew manifested so much humanity to the inhabitants, as to call forth the personal thanks of the Bishop of the Diocese, conduct which must have impressed the Spaniards with the most exalted ideas of the nobleness of character and heroism of British seamen.

‡ The combined fleets of France and Spain, on the arrival of Lord Nelson in the West Indies, notwithstanding their numerical superiority, immediately sailed for Europe; a transaction which, while it stamps the highest reputation upon the British name and arms, covers with indelible disgrace the naval character of the enemy. The unceasing activity of Nelson compelled him to, what even his modesty could not refuse the term of, a pursuit, and the novel scene presented itself to an admiring world of 17 sail of French and Spanish ships of the line, flying before a force of the same class bearing the British ensigns.

treatment or exchange of Capt. Wright,* of His Majesty's sloop *Vicenzo*,† and now a prisoner of war in close confinement in France.—13. *Hydra* (Spanish) schooner, 28 guns, 102 men, taken by the *Melampus*, 36, S. Pointz, at sea.—17. *Ranger*, sloop, *Charles Coote*, 16, B. 1790, captured by the *Rochfort* squadron, being previously so damaged by her crew that the enemy were obliged to burn her.—19. *Bianche*, Z. Mudge, 36, B. 1801, taken and afterwards burned in lat. 20 deg. N. long. 66 deg. W. after a most gallant resistance against a French squadron, consisting of two frigates, and two sloops.—22. Vice-Admiral Sir Robert Calder, with a detachment of the Channel fleet, consisting of 15 sail of the line, 3 frigates, and a lugger, defeated † off Ferrol the combined fleets of France and Spain, 20 sail of the line, 3 fifty gun ships, 6 frigates, and 3 brigs, capturing two Spanish ships of the line, viz. the *San Rafael*, 84, and *El Firnee*, 74. The action lasted four hours. The fleets remained in sight till the 24th, when the French got into Ferrol, and from thence some time after they put into Cadiz.—24. *La Petite Aricere*, (French) 4 guns, 35 men, taken by the *Grenada* brig, 10 guns, Lieut. J. Burke. *El Santa Maria Magdalena* (Spanish) felucca, 1 gun, taken by the *Superieure*, schooner, 12, W. C. Bromow, West India.

August 5. Dove cutter, *A Boyack*, 6, taken by the *Rochfort* squadron. Sheerness, Lord G. Stuart, 44, B. 1787, lost in a gale of wind off Trincomalee Bay, Ceylon, crew saved.—11. *L'Hazard* (French) gun boat, 14 men, taken by the *Dominica* sloop, H. Peter, Leeward Island Station.—13. *La Caridad Perfecta*, 12, (Spanish) schooner, taken by the *Marianne* schooner, Lieut. James Smith, under the batteries of Truxillo, after sustaining a very heavy and constant fire from the fort, in addition to the resistance of *La Caridad*.—15. *La Fanne*, 16, (French) corvette, taken by the *Goliath*, H. Barton, and *Camilla*, B. W. Taylor, Channel.—16. *La Touche*, 18, (French) corvette, taken by the *Goliath*, 74, R. Barton, Channel. *Plumber*, gun brig, Lieut. H. Garrety, 14, B. 1804, and *Teazer*, gun brig, Lieut. G. L. Ker, 14, B. 1804, taken off St. Maloes by five French gun brigs. *Pigny*, Lieut. W. Smith, (2) 14, T. 1779, wrecked in St. Aubin's Bay, Jersey, crew saved. *Althorpe cotter*, Lieut. W. Scott, 16, (hired) foundered in the Channel.—10. Capt. Baker of the *Phoenix*, (36), captured the *La Didon*, of 44 guns and 330 men, a remarkably fine frigate, and the fastest sailer in the French navy. The action commenced at a quarter past nine in the morning, and lasted three hours, within pistol shot, during which all the ropes of the *Phoenix* were cut to pieces, her main-topsail yard shot away, and most of her masts and yards severely wounded. The necessity for Capt. Baker engaging to leeward, in order to prevent the possibility of the enemy's escape, exposed the *Phoenix* to several raking broadsides before it was prudent to return the fire; and the superiority of *La Didon's* sailing, added to the adroit manœuvres of her Captain, Milins, showed the skill and gallantry with which Capt. Baker had to contend. Owing to the lightness of the wind, and *La Didon's* attempt to board, the starboard quarter of the *Phoenix* was brought in contact with her larboard bow, in which position she remained full three quarters of an hour, subject to a galling fire of musketry, which robbed Capt. Baker of such support of officers and men as could not be compensated but by the complete victory which crowned this bloody conflict.—25. Sir Sidney Smith attempted to burn the *Boulogne flotilla*, by means of fire machines, called *Carcasses* or *Catamarans*. *La Ravauche*, (French) row boat, 14 men, taken by the *Dominica* sloop, R. Peter, Leeward Island Station.

September. *L'Hypolite*, 4, (French) corvette, and armed with 8 swivels, run ashore and destroyed on the Isle of Bourbon, by the *Duncan*, 18, Lieut. Sneyd (acting).—2. *La Prudente*, (French) row boat, taken by the *Dominica* sloop, R. Peter, Leeward Island Station.—12. Capt. Parke, of the *Amazon*, (38), captured the *Principé de la Paz*,|| a Spanish corvette privateer of 24

* Sir Sidney Smith, a friend of Capt. Wright, read a letter descriptive not only of the situation of Capt. Wright, and also of the engagement in which the *Vicenzo* was captured, but likewise of the subsequent hardships the gallant captain and his brave officers and crew had suffered, and were then suffering; towards the conclusion of his speech, Sir Sidney was so overcome by his feelings that he was at times deprived of articulation, and in the end obliged to break off abruptly.

† See note to December 23.

‡ The following are the names of the ships which composed the British line of battle on this occasion, with the names of their commanders, and the number of killed and wounded in each, viz:—*Hero*, 74, Hon. A. H. Gardner, 1 killed, 4 wounded; *Ajax*, 80, W. Brown, 2 killed, 16 wounded; *Triumph*, 74, H. Inman, 6 killed, 6 wounded; *Barfleur*, 98, G. Martin, 3 killed, 7 wounded; *Agamemnon*, 84, J. Harvey, 8 wounded; *Windsor Castle*, 96, C. Boyles, 10 killed, 35 wounded; *Defiance*, 74, P. C. Durham, 1 killed, 7 wounded; *Prince of Wales*, 98, Vice-Admiral Sir R. Calder, Capt. W. Cuming, 3 killed, 20 wounded; *Repulse*, 74, Hon. A. K. Legge, 4 wounded; *Raisonné*, 64, J. Rowley, 1 killed, 1 wounded; *Dragon*, 74, E. Griffiths, none; *Glory*, 98, Rear-Admiral C. Stirling, Capt. S. Warren, 1 killed, 1 wounded; *Warrior*, 74, S. H. Linzee, none; *Thunderer*, 74, W. Lechmere, 7 killed, 11 wounded; *Malta*, 84, E. Buller, 5 killed, 40 wounded; frigates, *Egyptienne*, 40, Hon. C. E. Fleming; *Sirius*, 36, W. Prowse, 2 killed, 3 wounded; *Brisk* cutter, Lieut. J. Nicholson, none; and *Nile* lugger, G. Fennel, none. Total 41 killed, 158 wounded. The enemy's fleet consisted of thirteen French and seven Spanish ships of the line: of the former there were one of 84 guns, four of 80, and nine of 74 guns; of the latter, one of 84 guns, four of 80, two of 74, and two of 64; besides the three ships armed en flûte, five frigates, and three brigs, above mentioned.

§ The *Phoenix* had 12 killed and 28 wounded, amongst the former were Lieut. Borinton, George Donelan, Master's Master, and John Fowers, Quarter Master. *La Didon* had 47 killed and 44 wounded.

|| This ship had taken the *Prince of Wales* Packet, and the *Lady Nelson*, Letter of Marque; part of the crew of the latter was found on board the privateer, and a considerable sum in specie.

guns and 4 brass swivels, with 160 men on board, chiefly French.—13. *Renomé*, (French,) 2 guns, 40 men, taken by the *Rein Deer* sloop, 16, J. Fyfe, West Indies.—18.*—26. *Calcutta*, Daniel Woodruffe, 50, P. 1793, taken, after a determined resistance, by a French squadron on passage as convoy, from St. Helena, near Scilly.—30. *El Galgo*, pierced for 14, (Spanish) schooner, taken by the *Port Mahon*, 18, S. Chambers.

October 2.—*L'Actæon*, 16, (French,) taken by the *Egyptienne*, 40, Hon. C. E. Fleming, off Rochfort. *Baracouta*, schooner, Lieut. J. Orchard, 4, B. 1804, wrecked on the *Jordan Kay*, off Cuba, crew saved, but made prisoners. Gen. Ferraud, (French,) felucca, 1 gun, 2 swivels, taken by the *Franchise*, 36, Capt. Macdonnell, Leeward Island Station.—4. *San Benite*, (French,) 1 gun, 18 men, taken by the *Nelley*, schooner, 14, Lieut. Carr.—5. *Cyane*† 34, (French,) corvette, taken near Tobago, by the *Princess Charlotte*, 38, C. Tobin, and carried into Grenada.—6. *Mestuo la Solidad*, (Spanish,) 6 guns, taken by the *Eurydice*, 24, W. Hoste.—11. A Spanish gun-boat, No. 4, taken by the *Dexterous* gun-brig, 14, Lieut. R. Tomlinson, off Gibraltar. *Squib*, (F. V.) 4, (hired,) driven on shore and bilged near Deal, crew saved.—13. *Naiade*, 22, (French,) corvette, (since Melville,) taken by the *Jason*, 32, W. Champain, Leeward Island Station. *Orquillo*‡ (S.) C. Balder-son, 18, foundered in a gale, Jamaica Station; 95 of her crew lost.—19. *La Precieuse*, (Spanish,) cutter, 3 guns, 27 men, taken by the *Wolf*, 18, C. C. Mackenzie, Jamaica Station.—21. The greatest Naval Victory on record obtained by the British fleet, of 27 sail-of-the-line, including 3 sixty-fours, commanded by Vice-Admiral Lord Viscount Nelson, off Cape Trafalgar, near Cadiz, over the United French and Spanish squadrons, consisting of 33 ships, (of which 18 were French, and 15 Spanish,) commanded by Admiral Villeneuve. The Spaniards, under the direction of Gravina, wore, with their heads to the northward, and formed their line of battle with great closeness and correctness; but as the mode of attack was unusual, so the structure of their line was new—forming a crescent convexing to leeward, so that in leading down to their centre, Vice-Admiral Collingwood, the second in command, had both their van and rear abaft the beam. Before the fire opened, every alternate ship was about a cable's length to windward of her second ahead and stern, forming a kind of double line, and appeared, when on their beam, to leave a very little interval between them, and this without crowding their ships. Admiral Villeneuve was in the Bucentaure, in the centre, and the Prince of Asturias bore Gravina's flag in the rear; but the French and Spanish ships were mixed, without any apparent regard to order of national squadron. Lord Nelson, in the *Victory*, led the weather column; and Admiral Collingwood, in the *Royal Sovereign*, the lee. The action began at twelve o'clock, by the leading ships of the columns breaking through the enemy's line, Lord Nelson about the tenth ship from the van, Admiral Collingwood about the twelfth from the rear, leaving the van of the enemy unoccupied, the succeeding ships breaking through in all parts astern of their leaders, and engaging the enemy at the muzzles of their guns: the conflict was severe; the enemy's ships were fought with a gallantry highly honourable to their officers; but the attack on them was irresistible, and ended in a complete and glorious victory.¶ About three P.M., many of the enemy's ships having struck

This capture was the more satisfactory, as her Captain, François Beck, was an experienced cruiser, who commanded the French privateer *Le Brave*, during the late war, greatly to the annoyance of the trade.

* An action which Admiral Rainier, commanding in the Indian Seas, characterized "as ranking with the most famous of the defensive kind ever recorded in the Annals of the British Navy," should have appeared under date 18th Sept. in our Annals of 1804, but we were misled, it having been noticed as occurring in 1805, in a record to which we referred. It was fought by the *Centurion*, 50 guns, Capt. James Lind, acting commander, in Vizagapatam Road, in charge of a convoy, with the *Marengo*, 84, Admiral Lincoln, and two frigates. After two hours cannonading, vigorously continued on both sides, the *Marengo*, with the frigates and prize Indiaman, stood to sea. The *Centurion* was much damaged in her masts, yards, and rigging, but no men were killed, and only nine wounded, one of whom died soon after. The gallant Capt. Lind received the honour of Knighthood on his return to England in the spring of 1805; was made a K. C. B. in 1815; and died 12th June 1823.

† Formerly British. See May 12.

‡ Taken by the *Pique*. See February 8.

§ The order in which the British squadron attacked the combined fleets was as follows:—The ships which composed the van were the *Victory*, 100, Vice-Admiral Viscount Nelson, Capt. T. M. Hardy; *Temeraire*, 98, E. Harvey; *Neptune*, 98, T. Fremantle; *Conqueror*, 74, J. Pellew; *Leviathan*, 74, H. W. Baynton; *Ajax*, 74, Lieut. J. Pilfold (acting); *Orion*, 74, Edward Codrington; *Agamemnon*, 64, Sir E. Berry; *Minotaur*, 74, C. J. M. Mansfield; *Spartiate*, 74, Sir F. Laforey, Baronet; *Britannia*, 100, Rear-Admiral Earl of Northesk, Capt. C. Bullen; *Africa*, 64, Henry Digby. The frigates, &c. were the *Euryalus*, 36, Hon. H. Blackwood; *Sirius*, 36, W. Prowse; *Phoebe*, 36, Hon. T. B. Capel; *Naiad*, 38, T. Dundas; *Pickle* (sch.), 10, Lieut. J. R. Lapenotiere; *Entrepreantie* (cut.), Lieut. John Puver. The rear was composed of the *Royal Sovereign*, 100, Vice-Admiral Collingwood, Capt. E. Rotherham; *Mars*, 74, G. Duff; *Belleisle*, 74, W. Hargood; *Tonnant*, 80, G. Tyler; *Bellerophon*, 74, J. Cooke; *Colossus*, 74, J. N. Morris; *Achille*, 74, R. King; *Polyphemus*, 64, R. Redmill; *Revenge*, 74, R. Moorsom; *Swiftsure*, 74, W. G. Rutherford; *Defence*, 74, G. Hope; *Thunderer*, 74, Lieut. J. Stockham (acting); *Defiance*, 74, P. C. Dnrham; *Prince*, 98, R. Grindall; *Dreadnought*, 98, J. Conn.

¶ The battle of Trafalgar is justly ranked as the most glorious, whether in respect to the science and judgment with which it was conducted, the bravery and spirit with which it was fought, or its fortunate and brilliant result to the conquerors, ever recorded in the naval annals of our country.

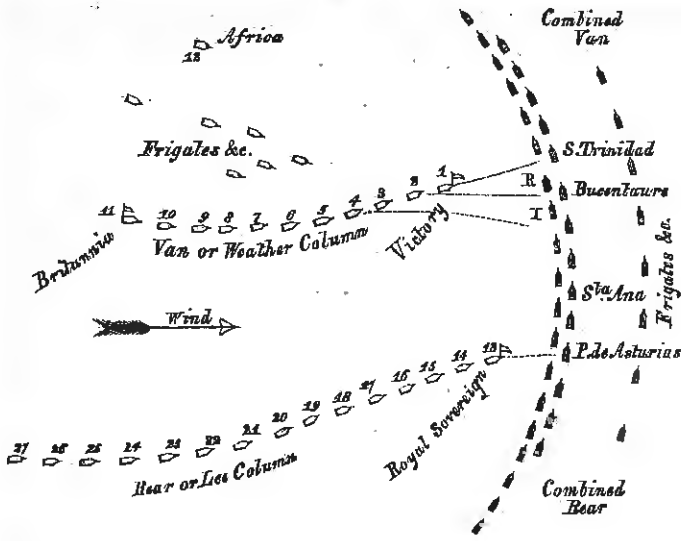

Disposition of the British and Combined Fleets immediately before the Battle off Cape Trafalgar.

R Le Redoutable. I L'Intrepide.
 1 Victory, 100, Lord Nelson.
 11 Britannia, 100, Rear-Adm. Earl of Northesk.
 13 Royal Sovereign, 100, Vice-Adm. Earl of Collingwood.

their colours, their line gave way; Admiral Gravina, with ten ships, joining their frigates to leeward, stood towards Cadiz.* The five headmost ships in their van tacked, and standing to the southward, to windward of the British line, were engaged, and the sternmost of them taken; the others † went off, leaving to His Majesty's squadron 19 ships-of-the-line, (of which two were first rates, the Santissima Trinidad, and the Santa Anna,) with three flag officers, viz. Admiral Villeneuve, Don Ignacio Maria D'Aliva, Vice-Admiral, and the Spanish Rear-Admiral Don Baltazar Hidalgo Cisneros. Such a battle could not be fought without a great loss of men. The Commander-in-Chief, Lord Nelson, received a musket-ball in his left breast, and soon after expired. ‡ Capts. Duff, of the Mars, and Cooke,

The enemy had a superiority of 6 sail-of-the-line, were fresh from port, and in the most perfect state of equipment, and against such odds, this splendid victory was gained through the transcendent abilities of Nelson, and the bravery of his officers and men, and which would probably have been extended to the capture or destruction of every vessel of the enemy, had not the wind been so dull as to prevent the rear of the British fleet from coming up in proper time. The coolness, intrepidity, and bravery of the British seamen on this occasion, exceed all praise; the result of the admirable discipline which prevailed in the fleet, and which, combined with their native courage, gave them a decided and terrible superiority over their adversaries during the conflict, who nevertheless evinced uncommon resolution and firmness: indeed, the shattered condition of the captured ships, and their dreadful loss in killed and wounded, sufficiently prove this fact.

* On the return of Gravina to Cadiz, he was immediately ordered to sea again, and came out, which made it necessary for Admiral Collingwood to form a line, to cover the disabled hulls; but blowing hard at night, Gravina's ship, the Prince of Asturias, was dismasted, and he returned into port.

† See November 3rd.

‡ At about 15 minutes after one, standing on the quarter-deck, moving, as was his custom whenever he was much pleased, the shoulder or rather sleeve of his right arm up and down with great rapidity, he received a wound from a musket-ball discharged by a marksman on the poop of the Bucentaure, which entered his left breast, and which he immediately declared to be mortal. To the

of the *Bellerophon*, were likewise amongst the slain. "After such a victory, it may appear unnecessary to enter into encomiums on the particular parts taken by the several Commanders; the conclusion says more on the subject than I have language to express; the spirit which animated all was the same; when all exert themselves zealously in their country's service, all deserve that their high merits should stand recorded; and never was high merit more conspicuous than in the battle I have described."—ADMIRAL COLLINGWOOD'S DISPATCH. The weather became so boisterous on the 22nd and 23rd, two days after the battle, as exposed the fleet to great danger; many of the prizes (13 or 14 in number) broke the tow rope, and drifted far to leeward before they were got hold of again; and some of them drifted upon the shore and sank. Admiral Collingwood, in these circumstances, determined to destroy all the captured ships that could be cleared of the men, considering that keeping possession of them was a matter of little consequence, compared with the chance of their falling again into the enemy's hands. This was accordingly effected. Four ships only of the many captured were brought into port.* There were 4000 troops embarked, under the command of Gen.

last moment of his life, which now ebbed fast, his solicitude for the event of the action never ceased; every consideration, save the anxious wish for the glory of his country, being dormant in him. He constantly, while below, demanded the news of the battle, and expressed the most lively satisfaction on being told it went well. About four his anxiety became extreme, and he repeatedly sent for Capt. Hardy, who fought his ship. This officer, however, could not consistently with prudence then quit the deck; at length, however, seeing the enemy striking their colours on every side, or flying the scene of action in confusion, assured of victory, Capt. Hardy carried the glad tidings to the dying hero, who after thanking God most fervently for the event, that he had survived long enough to have it made known to him, and that he had been enabled once more to do his duty to his country,—shortly after expired without a groan!

In this place we consider the prayer of the immortal Nelson, on going to battle, may be most appropriately introduced. A beautiful letter written by the late King, when Prince Regent, on the death of this hero, is given in our last volume, p. 132.

"May the great God whom I worship, grant to my country, and for the benefit of Europe in general, a great and glorious victory! and may no misconduct in any one tarnish it! and may humanity, after victory, be the permanent feature in the British fleet. For myself, individually, I commit my life to Him who made me, and may his blessing light upon my endeavours for serving my king and country faithfully. To Him I resign myself, and the just cause which is entrusted to me to defend.—Amen."

"All the virtues which could adorn human nature were to be found in the illustrious Nelson. The attribute of mercy was what most eminently distinguished him. In the language of the poet, it was not his wish to

'Wade through slaughter to a throne,
Or shut the gates of mercy on mankind.'

It was impossible the glorious example of such a man could be without a corresponding effect on the character of others. In this way was to be considered the conduct of many of those who were placed under his command.—Lord Hawkebury's Speech, Parliamentary Debates, Vol. 6, 1806. "The life and achievements of Lord Nelson would continue to animate the British Navy to the end of time."—Lord Castlereagh's Speech, ib.

* Abstract, showing how the combined fleet was disposed of:—Sent to Gibraltar 4; destroyed 15; in Cadiz, wrecks 6; ditto serviceable 4; escaped 4; total 33. Names and Rank of the flag-officers of the combined fleets:—Admiral Villeneuve,; Commander-in-Chief, Bucentaure, taken; Admiral Don Frederico Gravina, Principe de Asturias, escaped into Cadiz, wounded in the arm; Vice-Admiral Don Ignacio Maria D'Aliva, Santa Ana, severely wounded in the head, taken, but was driven into Cadiz; Rear-Admiral Don Baltazar Hidalgo Cisneros, Santissima Trinidad, taken; Rear-Admiral Magou, Algeiras, killed; Rear Admiral Dumanoir, Formidable, escaped.

SHIPS TAKEN OR DESTROYED.

FRENCH.	SPANISH.
Swiftsure, 74, (formerly British).	San Ildefonso, 74.
Fougeux, 74.	San Juan Nepomaceno, 74.
Indomptable, 84.	Bahama, 74.
Bucentaure, 80.	Monarca, 74.
Berwick, 74.	San Francisco de Anis, 74.
L'Aigle, 74.	El Rayo, 100.
L'Attila, 74. Blew up during the action.	Neptuno, 84.
Redoubtable, 74. Sunk after the action.	San Augustin, 74. Burned.
Intrepide, 74. Burned.	Santissima Trinidad, 136. } Sunk after the Argonauta, 80. } action.

† On Admiral Villeneuve's return from the West Indies, the French official paper, the *Moniteur*, had severely glanced at his conduct. Buonaparte had also spoken sarcastically of him, and it was generally understood that his command was about to be taken from him. Strung and mortified by these circumstances, he determined, contrary to the wish of the Spaniards, to give battle to Lord Nelson, who anxiously awaited him. He considered that a victory over the greatest naval hero of the age would have redeemed his character and covered him with glory, while a defeat could have added but little additional disgrace to his state of humiliation.

Contamin, who was taken, with Admiral Villeneuve, in the Bucentaure. The loss on board the Victory, Lord Nelson's flag-ship, was more severe than that of any other ship; Vice-Admiral Collingwood's ship was the next greatest sufferer. The total loss of the English in this dreadful battle was:—officers 36 killed, 98 wounded; seamen, &c. 387 killed, 1056 wounded; making 423 killed, and 1154 wounded; Total 1587. The number of killed, wounded, and drowned of the combined fleets is not known, but must have been immense. Admiral Collingwood issued a General Order for a Thanksgiving Day on account of this glorious victory.*—St. Pedro, (Spanish,) corvette, 16 guns, 70 men, taken by the Iris, 32, T. Lavre, at sea.—22. Amphion, (Spanish,) ketch, 12 guns, 70 men, taken by Latona, 38, T. L. M. Gosselin, at sea.—29. Le President, (French,) brig, 4 guns, 70 men, taken by the Narcissus, 32, R. Donnelly, coast of Africa.

November 3.—The four French ships-of-the-line which had escaped from the battle of Trafalgar, taken by Commodore Sir Richard Strachan, off Cape Ortegal.† “At half-past three the action ceased, the enemy having fought to admiration, and not surrendering till their ships were unmanageable.” “If any thing could add to the good opinion I had already formed of the officers and crew of the Cæsar, it is their gallant conduct in this day's battle.” “The Captains of the ships-of-the-line and frigates speak in high terms of their officers and ship's companies.”—DISPATCH.—5. A Thanksgiving-day was ordered for the victory of Trafalgar. Golondrina, (Spanish,) lugger, 4 guns, 26 men, taken by the Pomone, 38, W. G. Lobb, coast of Spain.—10. Biter, gun-brig, Lieut. T. Wingate, 14 B. 1801, run aground and destroyed near Calais, crew saved.—13. The Vengeur, (French,) brig, 14 guns, 50 men, taken by the Cruiser, sloop, 18, J. Hancock, Channel.—18. Woodlark, gun-brig, Lieut. Thomas Innes, 14 B. 1788, run aground and destroyed near St. Valery; crew saved. Les Dos Asares, (Spanish,) schooner, 2 guns, 30 men, taken by the Bacchante, 20, R. Macdonnell, Jamaica Station.—21. Bellona, (French,) schooner, 4 guns, 50 men, taken by the Renard, sloop, 18, Jeremiah Coghlan.—25. Brilliano, (Spanish,) lugger, 5 guns, 55 men, taken by the Aurieux, 18, J. Johnstone, off Portugal.

December. — Pigeon, schooner, J. S. Buckraft, 4 P. 1805, lost off the Texel; crew saved, but made prisoners.—10. Andromeda, (French,) 4 guns, 43 men, taken by the Spider, schooner, 14, Lieut. H. Shaw, Mediterranean.—16. L'Elizabeth, (French,) 14 guns, 102 men, taken by the Kingfisher, sloop, 18, N. D. Cochrane, Leeward Islands.—23. Sir Robert Calder tried by court-martial for not bringing the French fleet a second time to action.‡—24. La Febre, 40, (French,) taken by La Loire, 40, F. L. Maitland, and L'Egyptienne, 40, Lieut. P. C. Handfield, (acting,) off Rochfort. Napoleon, (French,) ship, 32 guns, 250 men, driven on shore and wrecked near the Cape

* The honour of an Earldom to the representatives of the revered Nelson, with the accompaniment of a national residence and the means of due dignity, and a liberal provision to Lady Nelson, were quickly accorded by the King and Parliament. An annuity of 2000*l.* per annum, and a Peerage, were awarded to Admiral Collingwood, which the duration of a life worn out in the service did not permit him to enjoy; and the Order of the Bath to the third in command, who, already ennobled by birth, now doubly sealed it in glory. The City of London voted its freedom and a sword of 200 guineas value to Admiral Collingwood, and the freedom and a sword of 100 guineas value to Lord Northesk.

† Sir Richard Strachan's squadron consisted of the Cæsar, 80 guns; Hero, 74, Hon. A. H. Gardner; Courageux, 74, Richard Lee; and Namur, 74, L. W. Halsted; accompanied by the Santa Margarita, 36, W. Rathbone; Æolus, 32, Lord William Fitzroy; Phoenix, 36, Thomas Baker; and Revolutionaire, 36, H. Hotham. The French consisted of the Duguay Trouin, 74, (since Impiacable,) Capt. Toufflet; Formidable, 80, (since Braave,) Rear-Admiral Dumanoir; Mont Blanc, 74, Capt. Villegrey; and Scipion, 74, Capt. Baronger. The action began about noon, and ended at half-past three o'clock. The British had only 24 killed and 111 wounded. This small loss arose, as explained in the dispatches, from the enemy having (a usual fault with French sailors) “fired high,” and the English (a corresponding virtue in our seamen) having “quickly closed.” The thanks of Parliament were given for this service; also a pension of 1000*l.* to Sir Richard; and the City of London voted him its freedom and a sword of 100 guineas value.

‡ That 15 sail-of-the-line (See July 22nd), should not only withstand 20 of those of the enemy, and three large 50 gun ships, but also capture two of their largest vessels, was an event certainly well calculated to maintain the character of superiority which the Navy of England so justly challenges. It had happened, unfortunately, that the Admiral's dispatches, as well as the verbal report of the officer who brought them home, gave the strongest foundation for the belief that the action would be renewed upon the following day; the result of which, to an enemy already beaten, must be deemed almost total destruction. The public disappointment was, therefore, extreme, when intelligence arrived which put an end to all hopes of the kind, and led to the belief that the shattered squadrons of the enemy had gained, without farther molestation, a Spanish port. The murmurs of disapprobation at the conduct of the British Admiral were so little restrained, that Sir Robert Calder returned to England to demand an investigation of his proceedings. He was accordingly tried by court-martial, and the Court decided that the Admiral had not done his utmost to take or destroy every ship of the enemy which it was his duty to engage, but at the same time ascribed such conduct to error in judgment, and sentenced him to be severely reprimanded. Sir Robert had at this time meritoriously served for forty years, and was Captain to Earl St. Vincent on the proud day which gave that brave officer his title.

of Good Hope by the Narcissus, 32, R. Donnelly.—28. Le General Blanchard, (French,) 10 guns, 130 men, taken by the Favourite, sloop, 18, J. Davie, Coast of Africa.

During this year Buonaparte had vigorously pursued his plans for the invasion of Great Britain, having 100,000 men encamped on the French coast, while his Botilla* was assembled at Boulogne. The whole was, however, broken up on the commencement of the war with Russia and Austria.

OBITUARY, 1805.

October 23. Rear-Admiral R. Palliser Cooper, on the Superannated List.

November 23. At his seat at Sidmonton, Hants, Admiral Sir Richard Kingmill, Bart. aged 74.

COMMANDING OFFICERS WHO LOST THEIR LIVES IN THE SERVICE.

Vice-Admiral Right Hon. Lord Viscount Nelson, Victory, 100, killed.

Post-Captain William Henry Jervis, Tonnant, 80, drowned.†

Post-Captain George Duff, Mars, 74, killed.

Post-Captain John Cook, Bellerophon, 74, killed.

Commander William Temple, Geolan sloop, 16, drowned.

Commander Henry Burke, Seagull brig, 18, drowned.

Commander James Toppet, Hawke sloop, 18, drowned.

Commander William Woolsey, Papellon sloop, 18, drowned.

Lieutenant J. Eddes Baker, Winchelsea, 32, drowned 12th April, in endeavouring to join his ship from New Southend, Essex, the jolly boat upsetting.

Lieutenant James Marshall,† Watchful gun-brig, 14, drowned.

Lieutenant William Scott, Althorpe, (hired cutter) 16, drowned.

Lieutenant T. S. Pacey, Mary, (hired cutter) drowned.

* State of the French Flotilla at the different Ports of France on the 20th July 1805, with the number of men and horses it was destined to carry.

Vessels of the Flotilla forming in three divisions, (collected from the different French Ports) that had assembled at the Ports mentioned, were ascertained to be,	Total Number of Vessels of the Flotilla.	Ordered to be conveyed by the Flotilla, viz.		Ports' Names, viz.							Total Number of Vessels of the Flotilla.	
		Number of Soldiers, Seamen, and Marines.	Number of Cavalry and Artillery Horse.	Ostend.	Dunkirk.	Calais.	Ambretteuse.	Vimereux.	Boulogne.	Hesles.		
												No.
Frames	No. 17	No. 1,920	No. 840	—	—	—	—	—	—	—	—	No. 17
Bombardes, Paque Boats, and Avisos	12	480	50	—	—	—	—	—	—	—	—	12
Gun Vessels { French	924	80,885	678	30	—	2	1	144	530	217	—	924
{ Dutch	280	28,038	404	—	131	14	135	—	—	—	—	280
Caiques, Corvettes de Feche and Péniches	88	9,315	233	—	—	81	—	—	22	1	—	88
Vessels of War	1,839	130,638	2,219	30	131	08	139	144	578	219	—	1339
Transports	954	30,377	6,840	25	26	105	34	92	526	146	—	954
Grand Total	2,293	161,215	9,059	55	157	203	173	236	1104	365	—	2293
Order of Transports		2,430										

Twelve regiments of cavalry and twenty-three of infantry were ordered to be stationed on the coasts of France, and none are included in the above statement, and also the different vessels bought, built, and the great number of fishing-boats ordered to be ready to embark troops, &c. to Dieppe, Havre-de-Grace, Rochelle, Rochfort, St. Malo, all not included in the preceding account; according to the French information received by the French Government, the military force of Great Britain was ascertained to be, viz. 351,000 volunteers, 99,000 regular troops, 87,000 militia, 75,000 Irish volunteers, and 25,000 sea fencibles.

† By the upsetting of his barge as he was proceeding to Sir Charles Cotton (who commanded before Brest in the absence of Admiral Cornwallis) with intelligence respecting the enemy's squadron. He was nephew and heir to Earl St. Vincent.

‡ He was killed by a cannon-ball off the coast of Boulogne, at the moment he was ordering his men to cheer. The shot entered his right side, just above the hip-bone, carrying away his bowels and some of the lower ribs. He was a brave and meritorious officer, had been 23 years a Lieutenant, and engaged in numerous actions.

BIRTHS, MARRIAGES, AND DEATHS.

BIRTHS.

March 25th. At Noyadd Trefawr, in the county of Cardigan, the Lady of Capt. Charles Hope, of H. M. S. Tyne, of a daughter.

March 27th. The Lady of Lieut. W. H. Lloyd, R. N. of a daughter.

March 29th. The Lady of Capt. Serjeantson, 50th Regiment, of a daughter.

At Stoke, the Lady of Charles Brown, Esq. Master of H. M. S. Caledonia, of a son.

The Lady of the Hon. Capt. Maude, C.B., R.N. of a daughter.

April 2nd. At Knowhead Cottage, Airshire, the Lady of Lieut. W. Rowley Wynyard, R.N. of a son.

April 10th. At Edinburgh, the Lady of Rear-Admiral Campbell, of a son.

April 10th. At Brighton, the Lady of Capt. Townshend, late of H. M. S. Columbine, of Ball's Park, Hertfordshire, of a son and heir.

April 12th. The Lady of Capt. Whylock, R. M. of a daughter.

April 13th. The Lady of Lieut. Ellis, of a daughter.

April 19th. At Eastbourn, the Lady of D. B. Conway, Esq. Surgeon, R.N. of a son.

April 19th. At Plymouth, the Lady of Lieut. Edward Tyndall, R.N. of a daughter.

April 22nd. The Lady of Capt. Parke, late Paymaster, R. M. of a son.

April 22nd. At Elm Grove, Southsea, the Lady of Lieut. and Quartermaster Hewett, R. M. of a daughter.

MARRIED.

March 26th. At Up Marden, Arthur Vausitart, Esq. of the 2nd Life Guards, son of Lord Bexley, to Diana Sarah, third daughter of Gen. Crooble, of Watergate Park.

At Bath, Lieut. John Tylden, of the Royal Artillery, to Catherine, eldest daughter of the late Colonel F. Williams, of the Royal Marines.

April 2nd. At Manchester, Capt. W. D. Davies, of the Queen's Bays, to Susan Jane Forbes, only daughter of the late John Abernethie, Esq.

Capt. Fox Maule, late of the 79th Cameron Highlanders, eldest son of the Hon. William Ramsey Maule, M.P., and nephew to the Earl of Dalhousie, to the Hon. Miss Abercromby, eldest daughter of Lord and Lady Abercromby, and niece to Viscount Melville.

April 5th. At Blotherwycke Park, Northamptonshire, by the Rev. J. Irvine Irvine, Com. John King, R. N. to Margaret, daughter of the late Joseph Harrison, Esq. of Tidd Manston, Cambridge, and sister to Everson Harrison, Esq. of Telethorpe Hall, Rutlandshire.

April 6th. At Plymouth, H. Caswell, Esq. Surgeon, of H. M. S. Druid, to Miss Susan Truman.

April 9th. At St. Martin-in-the-Fields, Lieut. R. P. Lloyd, Queen's Royal Regiment, son of Capt. William Lloyd, R.N. to Dorothea Maria, second daughter of the late Lieut.-Gen. Sir Henry Oakes, Bart. Mitcham Hall, Surrey.

At Yonghal, Capt. T. O. Partridge, 77th Regiment, to Mary Ann, youngest daughter of the late J. Bateman, Esq. of that town.

Lieut. Kelsall, 83rd Regiment, to Arabella, only daughter of Joseph Lipssett, Esq. of Ballyshanon.

In Wexford, Lieut. Henry Lyster, R. N. to Elizabeth, second daughter of the late Gen. Hutton.

April 14th. At Richmond, Capt. Henry Jelf, 36th Regiment, third son of Sir James Jelf, to Miss Charlissa Amelia Sharp, of Kincarrochy, Perthshire, daughter of the late Major Sharp, of that place.

April 16th. At Stonehouse Chapel, Lieut. R. W. Tracey, R.N. to Elizabeth, eldest daughter of W. Dowand, Esq. of Cork.

April 18th. At Athlone, Capt. Thomas Walsh, of the 5th Regiment, to Anne, eldest daughter of William Spread, Esq. of that town.

DEATHS.

March 24th, 1831. At Wexham Lodge, Bucks, Lieut.-Gen. Roberts, East India Company's Service.

Jan. 19th. At Dublin, Lieut.-Colonel Tucker, late Royal Irish Artillery.

CAPTAINS.

Sept. 20th, 1830. Peers, h. p. 92nd Foot.

Sept. 25th. At Canada, Lillievr, h. p. Newfoundland Fencibles.

Nov. 24th. Vassar, h. p. 1st Provisional Battalion of Militia.

Feb. 18th, 1831. At Liverpool, Ridgeway, h. p. 26th Foot.

March 6th. At Dungannon, Speer, h. p. 1st Foot.

Oct. 10th, 1830. At Kirkee, Bombay, Thompson, Surgeon, 4th Dragoons.

LIEUTENANTS.

August 15th, 1830. At Dominica, De Ravariere, h. p. 60th Foot.

Sept. 21st. At Berhampore, Bengal, Fleming, 49th Foot.

Sept. 25th. At Berhampore, Bengal, Mathew, 40th Foot.

Oct. 22nd. At York, Upper Canada, Brooke, late 5th Royal Veteran Battalion.

Oct. 31st. At Quebec, Weatherstone, h. p. Canadian Fencibles.

Jan. 17th, 1831. Moorhead, h. p. 60th Foot. McKay, h. p. 3rd West India Regiment.

Feb. 7th. Huggap, h. p. 7th Foot.

Feb. 9th. At Bourdeaux, Walker, h. p. 7th Foot.

March 2nd. Raymond, h. p. 57th Foot.

March 6th. At Leeds, Moss, (Adjutant of Leeds Recruiting District.)

March 7th. Butler, 39th Foot, on passage from New South Wales.

Champion, h. p. 12th West India Regiment.

August 1830. At Jersey, Cornet Griffiths, h. p. Waggon Train.

July 8th. Armstrong, h. p. 21st Foot.

QUARTER-MASTERS.

Feb. 1831. Davenport, h. p. 16th Dragoons.

Feb. 8th. Kenny, h. p. 32nd Dragoons.

March 1st. Hayes h. p. 2nd Fencible Cavalry.

March 11th. Christian, h. p. 2nd Manx Fenc.

COMMISSARIAT DEPARTMENT.

Jan. 21st, 1831. At Corfu, Assistant-Commissary Pecco, h. p.

Jan. 26th. At Guernsey, Assistant Commissary Gen. Corbin, h. p.

Capt. John Hamilton Edwards, 46th Reg.

March 20th. At Bilding, near Killala, Ireland, Lieut. Henry Fitzmaurice, R.N. of the Preventive Service.

At Southsea, Lieut. Nelson Collingwood Simmonds, R.N.

At Cork, Mr. Gun, Purser R.N.

At Bosham, Lieut. Cook, R.N.

March 31st. Lost in a Steam-Packet off Swansea, Major-General M'Leod, C.B. Appointed Ensign in the 78th Foot in 1793, and Lieutenant in 1794. He served at the Cape of Good Hope in 1795, and was present in the three actions, and at many skirmishes: he was also present at the capture of the Dutch squadron in Saldanha Bay. He was appointed to a company in the 95th Foot, and subsequently returned to England; the regiment being drafted, and the officers placed on half-pay, and from thence appointed in 1799 to the 4th Foot. He served on the staff in England and Ireland; afterwards in the Helder expedition; and was in the actions of the 2nd and 6th of October in Holland. In 1802, he obtained a majority in the 4th Foot, and was placed on half-pay at the peace. In 1803, he was restored to full-pay, and employed on the staff in England till June 1804, when he was appointed to the 95th Foot. He next served in the expedition to South America, and was engaged in the attack upon Buenos Ayres. He afterwards served in Spain and Portugal, and was present at the battle of Corunna. In 1809, he received the Brevet of Lieutenant-Colonel; in 1810, was appointed Lieutenant-Colonel of the Royals; in 1819, Colonel in the army; and in 1830, Major-General.

April 1st. At Plymouth, Com. Thomas Bond, R.N. (retired.)

April 3rd. Capt. Mudie, R.N. in the 76th year of his age.

April 4th. At his apartments in the Aylm at Greenwich Hospital, Capt. Donald M'Leod, R.N. C.B., aged 64 years. This officer entered the Navy at an early age, and after having served the usual period, passed his examination for Lieutenant, to which rank he was promoted Jan. 2nd, 1794. He subsequently served in the Namur and several other ships; and on the 29th April, 1802, was promoted to the rank of Commander. At the renewal of hostilities in 1803, he was in May of that year, appointed to command the Sulphur Bomb-vessel, in which he assisted at the attack on the gun-vessels and other craft and batteries on the pier of Granville, by Sir James Saumarez, in the Cerberus, Capt. Selby, on the 13th Sept. 1815. In the Catamaran expedition, (as it was termed,) against the Boulogne flotilla, he was the senior commander, and although the attempt was not attended with any favourable results, yet it afforded Capt. M'Leod an opportunity of displaying much ability. Capt. M'Leod was next appointed to command the Cygnet; and on the 22nd Jan. 1806, he was promoted to the rank of Captain. During the expedition against Copenhagen, in 1807, he commanded the Superb, (74,) bearing the pendant of Commodore (now Sir Richard) Keats; and he afterwards served, on the promotion of that gallant officer to the rank of Rear-Admiral, as his Flag-Captain, and also to Rear-Admiral William A. Otway, and to Vice-Admiral Joho Holloway, when the latter commanded at Newfoundland. In 1810, Capt. M'Leod superintended

the impress service at Liverpool, where he remained until the termination of hostilities. On the escape of Buonaparte from Elba, Rear-Admiral W. H. Scott hoisted his flag as Commander-in-Chief in the Downs, and Capt. M'Leod became his Flag-captain; and in Dec. 1815, after the extension of the Order of the Bath, Capt. M'Leod was nominated one of the Companions. After Admiral Scott struck his flag, Capt. M'Leod was not employed until 1819, when he was appointed to superintend the ships in ordinary at Chatham, where he remained until 1822; and on the 19th April, 1824, was appointed one of the Captains of Greenwich Hospital, when on the promotion last year of Capt. M'Kinley to the rank of Rear-Admiral, he succeeded that officer as superintendent of the boys in the lower school of that establishment. Capt. M'Leod has left a widow and family to lament his loss.

At his residence near Clifton, Capt. Waltus, R.N. Mr. S. Cooke, Master, R.N.

April 6th. Mr. James B. Sandercomb, late Purser, of H. M. S. Chanticleer.

April 6th. At Whitehill, near Glasgow, in consequence of the wounds which he received at the battle of Argaum, in the East Indies, in 1803, James Donald, Esq. formerly Captain and Paymaster of His Majesty's 94th Regiment.

April 7th. General the Earl of Mulgrave, G.C.B. His Lordship's military career commenced during the American War; he arrived at the rank of Lieutenant-Colonel in 1780; and in 1809, became a full General. He served in America from early in 1776 to the end of 1778; in the West Indies in 1790; and in 1793, commanded at Toulon. In the following year he served in Zealand; and in 1799, he was employed on a military mission to the Archduke Charles and Marshal Suwarroff. He was a principal member of the Pitt, Perceval, and Liverpool Administrations, filling in succession the offices of Chancellor of the Duchy of Lancaster, Secretary of State for Foreign Affairs, First Lord of the Admiralty, and Master-General of the Ordnance, the last he resigned in 1818, when he was succeeded by the Duke of Wellington. His Lordship had been for some years in a declining state of health, and at length closed a meritorious life in his 77th year, at his seat, Mulgrave Castle, Yorkshire. Lord Mulgrave, at the time of his death, was Colonel of the 31st Foot, and Governor of Scarborough Castle. He is succeeded in his title and estates by his eldest son Viscount Normanby.

April 11th. Colonel Robert Murray Macgregor, late of the East India Company's Service.

April 14th. At Haslar Hospital, Lieut. C. Robertson, R. M.

April 16th. At his house in Wigmore-street, Lieut.-Gen. Sir William Payne Galloway, Bart. Colonel of the 3rd Dragoon Guards.—Obituary next month.

April 22nd. Capt. Thomas C. Watson, late of the 3rd King's Own Light Dragoons, aged 59.

April 22nd. At his residence, in Godalming, Lieut.-Colonel Fielder King, in his 78th year.

April 23rd. At Portsmouth, Lieut. John Derby, (1796) Warden of that Dock-yard.

April 26th. In Harley street, Lieut.-General Lord Walsingham, Lieut.-Colonel of the 1st Dragoons. (An Obituary in our next.)

METEOROLOGICAL REGISTER,

KEPT AT THE OBSERVATORY OF CAPT. W. H. SMYTH, AT BEDFORD.

MAR. 1831.	Six's Thermometer.		At 3 P. M.			Fuvia- meter Inches.	Evapora- tor Inches.	Winds at 3 P. M.
	Maxim. Degrees.	Minim. Degrees.	Barom. Inches.	Thermo. Degrees.	Hygrom. Facts.			
1	51·3	35·2	29·62	49·0	630	—	·080	N.W. fresh breezes, fine.
2	47·4	37·8	29·65	46·8	830	·100	·064	S.W. squally, with rain.
3	50·2	40·2	29·68	49·2	809	·056	·080	W. by S. light br., cloudy.
4	53·0	47·4	29·67	52·8	740	·333	·050	S.W. light airs, fine morn.
5	53·2	47·3	29·56	49·2	804	—	·036	S. cloudy, with fine rain.
6	53·0	47·2	29·20	49·0	803	·105	·040	W.N.W. sq., threatening.
7	51·2	45·2	29·77	49·0	475	·150	·060	N.W. light airs, fine day.
8	53·0	43·2	29·15	48·3	621	—	·055	S.W. light breezes, clouds.
9	49·6	40·0	29·27	46·4	814	—	·070	S.E. fresh breezes, cloudy.
10	53·2	40·3	29·18	51·3	560	—	·090	S. light breezes, clouds low.
11	52·0	47·1	29·16	50·4	730	·100	·078	S.E. fresh breeze; and fine.
12	54·8	42·0	29·95	52·6	690	—	·090	S.W. a gale, but clear.
13	52·2	43·8	29·94	52·5	790	·210	·080	S.W. squally weather.
14	56·0	41·8	29·44	45·9	611	·518	·032	S.W. fr. breezes, and clear.
15	45·2	40·9	29·67	44·6	803	·285	·070	S.W. blowing hard, rain.
16	51·9	41·7	29·76	51·4	871	·065	·070	S.W. by S. wind, abated.
17	59·8	49·1	29·89	54·3	433	—	·065	N.W. fresh breezes, fine.
18	53·1	48·7	30·14	48·2	395	—	·060	W. light breezes, hazy.
19	50·1	43·9	30·12	47·2	510	—	·070	S.S.W. very light breezes.
20	50·8	44·0	30·04	48·3	596	—	·065	S.S.W. blowing hard.
21	54·7	46·8	30·10	50·2	677	—	·060	N. by E. fine breezes, hazy.
22	54·3	44·6	30·30	51·5	493	—	·070	N.E. to E. light breezes.
23	52·3	37·2	30·30	50·0	435	—	·060	N. fresh breezes, and hazy.
24	44·2	33·4	29·91	43·4	635	—	·044	N.E. fresh breeze, snow.
25	47·0	43·2	29·24	46·3	630	0·070	·059	E. by N. blowing hard.
26	48·2	40·0	29·77	47·6	850	0·630	·080	S.E. blowing fresh, showers.
27	56·3	44·9	29·92	56·3	454	·020	·100	S.W. light air, fine day.
28	59·8	45·0	30·06	55·7	497	—	·100	N. by E. fresh breeze, fine.
29	55·7	41·3	30·17	46·3	573	—	·090	N.E. by N. blowing fresh.
30	46·8	44·0	30·27	46·8	520	—	·066	N.N.E. very squally.
31	48·5	41·0	30·40	47·3	536	—	·080	N.E. by N. a gale, cloudy.

TO READERS AND CORRESPONDENTS.

The unusual length of some of our articles, and the quantity of technical matter, of immediate interest, pressing for insertion, obliges us to postpone many narratives—also our Reviews of Colonel Napier's Third Volume—Capt. Hall's Fragments of Voyages, &c.; together with our Literary Notices.

"Suum Cuique."—The remainder of the Paper will enable us to form a judgment. We have seen, however, sufficient to induce us to encourage future contributions from the same pen. There can be no objection to the other arrangements proposed.

We regret that the article communicated by "G. C." does not suit us. It will be returned if required.

The subject alluded to by "An Old Officer" had by no means escaped our attention. On the contrary, our sense of its importance had alone induced us to delay bestowing such notice upon it as the subject appeared to us to merit, and which, when duly considered, it shall receive.

Will "H. B. R." acquaint us through what channel we may address him, with a view to a compliance with his request?

"W. R. F." has reached us too late for our present Number. The irregularity of which he complains is of antient standing.

NAVAL BATTLES.

“Palmas qui meruit ferat.”

WE have just scrutinized a sound little volume* of inquiry into the conduct of Byron, Graves, Hood, and Rodney,—those gallant chieftains of the good old school, which Nelson justly boasted to have been nursed in. Capt. White writes with a manly firmness, yet so free from egotism, that we scarcely perceive him to have been an eye-witness of what he describes: and although we are not absolutely taken in tow by him, yet we cordially approve of the clear and tactical course of reasoning by which he has divested some generally received opinions, on certain naval movements, of the intricacies and contradictions which have hitherto enveloped them. The first duty which devolved upon the author, was a serious one,—no less than to refute the statements of Ekins, Clerk, and others, who have fought the battles of those brave leaders upon conceptions of their own: and in this he has completely succeeded. Nay more,—he has exposed, by positive proof, that *garbled* documents have been imposed on the public; and it must make the gallant Admiral ride rather uneasy at his moorings, on discovering how implicitly he has steered by a false light, and thereby been the involuntary means of scattering unmerited obloquy on officers, whose memory should be embalmed in their country's pride and gratitude. Nor is this the only objection we have to his desultory quarto on “Naval Battles.” A work which is likely to be studied as a pilot by those naval youths who are preparing for the momentous duties which await them, should bear fewer marks of negligence in detail, and obscurity in deduction, than unfortunately it now possesses. As an instance, we would demand who could, upon that evidence alone, estimate the disparity between the glorious battle of the Nile, and the destruction of the Turks at Navarino? But we trust the able and gallant author may yet give the Service a revised edition.

We consider the “Naval Researches” as a remarkably useful publication, because, there being always many more readers than reasoners, prejudices may, unless such pertinent criticisms are hove in, easily become so rooted as to baffle the ardour of inquiry. Now we have always deemed the extravagant claims set forth by the crafty scribes of the north, to their technical *Magnus Apollo* having caused the maritime greatness of these realms, to be a conspiracy against naval talent; or, as Mr. Burchell would have elegantly expressed it—“downright fudge.” With equal assumption might the hint in our last number be grappled at, and some future “Heathen” declare to the world the obligations which Wellington, Picton, and Anglesea, owe to the military genius of Hogg, North, and Sir Walter Scott! The work which forms the basis of their adulation has acknowledged merits; but they usually overlook that it assumes an enemy incapable of exertion, and discards the agency of circumstance and seamanship: for such a system the manageable ships which Mr. Clerk was wont to carry in his pocket, and absolute control over the evolutions of both fleets, are requisite:

* “Naval Researches; or a candid inquiry into the conduct of Admirals Byron, Graves, Hood, and Rodney.” By Capt. T. White, R. N. 1830.

and the battles must first be fought, in order to be dilated upon,—in the style of antiquated damsels during the deal at whist, doling out reasons for trumping in the previous hand.

Without refusing a just proportion of approbation to Mr. Clerk, we own to the “soft impeachment” of differing from his indiscreet friends, and utterly disbelieving that his book has been the means of working any change in naval tactics. Our scepticism is grounded upon some acquaintance with sea-life and studies. We cannot credit its marvellous influence, because we personally know that so far from having become a “Manual” in the British Navy, it has been but little read by sailors;—because its first edition does not convey the slightest conception of the operation in question;—because its twaddle upon Rodney’s victory was written for a second impression, after the fight was fought; because it was absolutely impossible for so old a manœuvre as breaking the line, to have been *totally* unknown in 1782;—because we do not perceive that any battle of our time has been gained according to Mr. Clerk’s system, as shown in the edition of 1782, unless the accidental affinity of that of Sir John Jervis, which arose from wind and weather, be adduced;—because the injudicious preface to the Tactics, reported to be written by a Naval Officer, contains assertions which are not borne out by naval testimony; and finally, because the candid exposition of Sir Howard Douglas, is equally unshaken by the flippancy of the Quarterly Review, and the insidious sophisms of the Edinburgh.

Many illustrious commanders were induced by entreaty to read the book, and every encomium which politeness dictated was duly displayed, while the animadversions of candour were as duly suppressed. “After studying the whole work,” says the veteran Howe, “I think it very ingenious; but for my part, when I meet with an enemy, I am still resolved to fight him in the old way.” And in this his lordship uttered the sentiments of every British seaman; for with whatever advantage the Man of Eldin may be consulted, every contest must continue to be regulated, “in the old way,” according to wind, wave, force, and all the train of accidents which prevent sea-fights from being reduced to dynamic dreamings.

It is due to this greatly agitated question to state, that Sir Gilbert Blane positively declares, though he spent a great part of his time in the Admiral’s cabin, that neither in the course of the voyage, nor at any subsequent time, did he ever hear the name of Mr. Clerk pronounced, either by Lord Rodney, or Sir Charles Douglas; that he never saw his book in their possession; and that he never heard of it till his return to England. And the gallant Admiral must also speak for himself. At the request of the late Gen. R. Clerk, who asked his opinion on the “Naval Tactics,” his Lordship wrote the following note, amongst others:—

“And it is well known, that attempting to bring to action the enemy, ship to ship, is contrary to common sense, and a proof that that Admiral is not an officer, whose duty is to take advantage of an enemy, and to bring, if possible, the whole fleet under his command to attack half or part of that of the enemy, by which he will be sure of defeating the enemy, and taking the part attacked, and likewise defeating the other part by detail, unless they make a timely retreat. During all the commands Admiral Rodney had been intrusted with, he made it a rule to *bring his whole force against part of the enemy’s*, and never was so absurd as to bring ship against ship, when the

enemy gave him an opportunity of acting otherwise; and, as he told the King, before any of his actions took place, that he would always take the lee-gage; first, because it prevented the enemy's retreat; secondly, because if any of his ships were disabled, by putting their helm a-weather, the next ship closed the line, and secured the disabled ship."

Capt. White's "Researches" open with a disquisition on the engagement between Byron and D'Estaing, off Grenada; and he warmly controverts the sarcasm in Admiral Ekins' work, that "with British intrepidity it might have ended gloriously," by demonstrating, that neither skill nor energy were wanting. He then justifies all the steps which were adopted; shows that both Clerk and Ekins have misconceived the mode and intention of the manœuvres of our fleet; and proves that the conduct displayed by its excellent commander-in-chief—though he fought with more heroism than fortune—was entitled to admiration. With respect to the plan of attack proposed by the author of "Naval Battles," it is only necessary to observe that, as the two fleets were never situated as the proposer assumes, refutation is unnecessary: nor indeed need a moment be lost in considering a plan which suggests no proceedings ulterior to assault, in case of difficulty or repulse: and which supposes the adversary to be unversed in tactics. The sketch is concluded by an exposition of the art by which the misrepresentations relative to this affair have been supported; and as Capt. White's pages may not fall into all naval bands, which by the by they ought to do, we subjoin the whole passage, with a view of pointing out the injurious tendency of the curtailments.

"In order to place the subject fairly before the reader, I will subjoin those parts of Admiral Byron's public letter which have been so unceremoniously abridged, distinguishing those passages which Rear-Admiral Ekins has omitted, by printing them between brackets thus [].

"EXTRACTS, WITH OBSERVATIONS THEREON.

"The signal was made for a general chase [in that quarter,*—as well as for Rear-Admiral Rowley to leave the convoy;] AND [as not more than fourteen or fifteen of the enemy's ships appeared to be of the line, from the position they were in, the signal was made] to form and engage as they could get up.†

"The enemy appearing not to exceed, at that time, fourteen or fifteen ships of the line, I cannot but think that the signals to chase, to form as convenient, and to engage as the ships could get up with the enemy, were decidedly the most judicious that could have been made, under the above circumstances; even if it had been the Commander-in-Chief's intention to attack the enemy's van—which it was not;—but which both Mr. Clerk and Rear-Admiral Ekins seem determined to maintain as an incontrovertible fact,‡ or else, why was the above passage rejected by the latter writer?"

"EXTRACT.

"But the enemy getting the breeze [of wind about that time,§] drew out their line [from the cluster they were in,] by bearing away and forming to leeward on the starboard tack, [which shewed their strength to be very different from our Grenada intelligence;|| for] it was plainly discovered they had

* "The S.W. quarter, doubtless."

† "Clerk's Tactics."

‡ "See the first 'Observation' in page 78 of 'Naval Battles.'"

§ "The time alluded to was when the weather ships of the enemy's fleet began to fire at the *Sullan*, *Prince of Wales*, and *Boyne*; the *Three Ships* that led into action."

|| "This intelligence, as before described, was communicated by the two schoon-

thirty-four ships-of-war, [twenty-six or twenty-seven of which were of the line, and many of these appeared of great force. HOWEVER] the general chase was continued, and the signal was made for close engagement; [but our utmost efforts could not effect that;] the enemy industriously avoided it, by always bearing up when our ships got near them; [and I was sorry to observe, that their superiority over us in sailing, gave them the option of distance, which they availed themselves of, so as to prevent our rear from ever getting into action.*]

“As the importance or non-importance of the omitted passages given above speak for themselves, they stand in need of no observation to strengthen their claim to the reader’s attention, except to notice the gallant, though proscribed ‘however.’

“EXTRACT.

“The ships that suffered most were the ships the action began with,† [AND] the *Grafton*, Capt. Collingwood, *Cornwall*, Capt. Edwards, and *Lion*, Capt. Cornwallis. The spirited example of Vice-Admiral Barrington [with the former three] exposed them to a severe fire in making the attack; [and the latter three happening to be to leeward, sustained the fire of the enemy’s whole line, as it passed on the starboard tack.‡]

“As some of my readers may not have it in their power to refer to the work entitled ‘Naval Battles,’ &c. I shall take the liberty of transcribing the above extract as it is given by Rear-Admiral Ekins, to enable them to form a comparison.

“The ships that suffered most were those the action began with; the ships of Captains Collingwood, Edwards, and Cornwallis: the spirited example of Admiral Barrington exposed them to a severe fire in making the attack.§

“How could that be the case when Captain Collingwood’s ship was next to the *Princess Royal* in the centre, and Captains Edwards and Cornwallis were in the rear with Rear-Admiral Parker? That these ships sustained injury in making the morning attack is very certain, but from very different causes than those assigned by the above extract; unless it were possible for them to be in the van, centre, and rear at the same moment of time.

“Mr. Clerk speaking of this action says, ‘the ships in the van were exposed, for a long time, to a heavy fire, they could not return.’

“Admiral Barrington could have immediately returned the fire of the enemy, but as it would have been throwing away powder and ball, he very wisely delayed doing so for ten or twelve minutes, when having got closer, he opened a destructive fire on the French centre,|| and a still more destructive

ers that escaped from Grenada on the approach of the French fleet; which intelligence at the time they left the island might have been correct, as the vessel sent to reconnoitre Fort Royal Bay, Martinique, on the 1st or 2nd of July, reported to Admiral Byron that thirteen large ships were seen there, with a flag at the fore on board one of them; no doubt to deceive. These ships might have been De la Motte Piquet’s squadron, who had only arrived there three days before D’Estaing sailed for Grenada, and might have remained for a day or two after.”

* “Clerk’s Tactics.”

† “Viz. the *Sultan*, *Prince of Wales*, and *Boyne*. By the omission of the conjunction—AND,—the laurels these ships acquired are transferred to the *Grafton*, *Cornwall*, and *Lion*.”

‡ “Clerk’s Tactics.”

§ “Naval Battles,” &c. &c. &c.”

|| “Forty minutes only elapsed between the time of the French beginning to fire, at the greatest possible distance a shot would go, and the *Sultan* passing close a-stern of the last ship in their line,—during thirty of which the British van were closely engaged while crossing.”

one on their rear, his line of march taking him very close to them. How long Mr. Clerk's '*long time*' lasted he has not condescended to inform his reader. Had the attack been in the manner he supposed it to have been, doubtless a '*long time*' would have elapsed ere Admiral Barrington could have returned the enemy's fire.

"Had Admiral Byron, as Mr. Clerk represents him to have done, chased N.W. in order to bring on the engagement, when the French fleet were first seen, he would have been running away from, instead of advancing towards the enemy.

"As Mr. Clerk's remaining observations on this action, are founded on the erroneous idea that Admiral Byron brought on the engagement by making an attack on the enemy's van, when he in fact began it by assailing the enemy's rear, it would be a waste of time to attempt to refute arguments grounded on such false data. I cannot, however, but remark, that he has shown so much ingenuity in the erection of a superstructure on so sandy a foundation, that none but those who have the opportunity to obtain better information than fell to his lot to be furnished with, could doubt of its authenticity, or question its correctness."

The action off the Chesapeak is then critically investigated; and the writer, in a fair and impartial analysis, completely exonerates Sir Samuel Hood from the charge of dilatoriness in obeying the signals of his commanding officer,—as also Admiral Graves from that of not having exerted himself in aid of the British army. And here, besides exposing the mutilation of the official report, he has to reprove Admiral Ekins for quoting that party-pander, the "*Political Magazine*," as sufficient authority for censuring the conduct of a commander, who was expected to refit where no resources existed, and who, to catch the enemy at anchor, must have rendered himself invisible. By a convenient mode of argument, this writer assumes, as incontrovertible positions, that which nobody else admits, and then boldly deduces such conclusions from them, as will best accord with, and establish his statements.

It should be remembered that Admiral Graves, in taking up Arbutnot's command, did not find it a bed of roses: the auspices were unfavourable in our land operations; and the fleet of De Grasse was hourly expected, to co-operate with that of Count de Barras, at Rhode Island. Aware that such an overwhelming superiority would defy opposition, the British Admiral, with only nineteen sail of the line, put to sea, in hopes of preventing the junction of the enemy's two divisions, and even of effecting their discomfiture in succession. Steering for the month of the Chesapeak, the foe was seen on the morning of the 5th of September 1781, and Admiral Graves, with the cool gallantry which always distinguished him, stood onwards, under courses, top-sails, and top-gallant-sails, with a fresh steady breeze. In the afternoon, when the tide served, the enemy got under way, and ran to leeward of the British fleet, forming the line of battle as they drew from the land. They were now discerned to consist of twenty-four heavy men-of-war, a circumstance which first convinced the English that Count de Grasse was actually arrived. Meantime, our fleet boldly advanced, until its van had passed so far on the contrary tack to that of the French, that the enemy's headmost vessel was almost abreast of our flag-ship, the *London*. The signal was then made to wear; and the English fleet approached that of the enemy as fast as De Grasse, who repeatedly edged away, would permit it. At a quarter past four

o'clock a cannonading began between the van of each fleet, and extended progressively. The contest continued till sunset, when the French, though not absolutely defeated, sheered off, and left us in possession of the *field*. The rival fleets continued five days in sight of each other, repairing their damages, and manœuvring, until Count de Grasse had obtained his object, by covering the arrival of M. de Barras, when he retired with his fleet into the Chesapeake, and anchored across that river, so as to block up the passage. No want of skill or gallantry was imputable; but the mortifying surrender of Earl Cornwallis, with 4017 men, to an army of 21,000, gave this event all the inconvenience of a discomfiture,—though clamour even could not colour it with disgrace. We are of opinion that the manner in which Admiral Graves led his fleet into action, was one of very doubtful merit; and the too early lasking away of some of the van ships, was an adverse circumstance. He had however a very superior foe to contend with; and the critical pressure of the times was such, as permitted but little exercise of discretion whether to fight, or avoid it. Aware that on him depended the fate of the American Colonies, his card was a difficult and perplexing one to play; had he decided upon attempting to intercept the Rhode island squadron, instead of running direct for the Chesapeake, more advantage to the cause might have resulted,—but as it was, he acquitted himself like a gallant and skilful officer. Yet the tavern politicians of London were loud in their invectives, that nineteen indifferent ships, did not sink, burn, capture, or destroy, twenty-four of the finest ships that had ever sailed from the ports of France!

In the diatribes of the day it was asserted, that Sir Samuel Hood, and his gallant division, had been tardy in coming into action; this our author indignantly refutes, and demands where Rear Admiral Ekins got his information: "Did that writer ever consult the London's Log lodged in the Navy Office? and will that Log, or the Log of any other individual ship in the fleet, confirm the statement thus published to the world? If they do, I shall be induced to fancy that what I that day saw and heard, was a mere chimera of the brain, and, that what I believed to be the signal for the line, was not a Union-jack, but an *ignis-fatuus* conjured up to mock me."

Capt. White next proceeds to discuss the unusually bold measure by which Sir Samuel Hood attempted to preserve the valuable island of St. Christopher's from its beleaguers. This was a proud epoch in our naval annals, and equally independent of Mr. Clerk and his system. The act of compelling an enemy of vastly superior force to quit an advantageous anchorage, dexterously snapping up his berth, and intrepidly defeating every attempt to force him from it, was an admirable lesson in tactics; and in studying the details, our admiration is divided, between the skill displayed by Sir Samuel in directing this masterly manœuvre, and the bravery and precision with which it was executed by those under his orders.

When Count de Grasse had accomplished his intended operations in the Chesapeake, he proceeded to the West Indies; though previous to attacking our interests in that quarter, he detached seven or eight sail of the line to escort a convoy to Europe, which had been detained at Cape François, ever since the preceding July, in order that he might keep his fleet entire. "If the British Government," says Capt.

White, "had sanctioned, or a British Admiral had adopted such a measure, however necessary to carry on an important political operation, the one would have been turned out, and the other would have been hung: no wonder that they succeeded, and we failed."

De Grasse was speedily followed by Sir Samuel Hood, who immediately repaired to Barbadoes, and moored in order of battle, in daily expectation of a hostile visit. But the opportune arrival of this squadron, small as it was, frustrated the designs of the French, who thereupon stood for St. Kitts, and there landed a force of 8,000 men. Hood having received intelligence that Gen. Fraser, with his small garrison of 600 men, had retreated before the invaders, and were closely pressed in the fortress at Brimstone-hill, determined upon a casting die for their preservation. Instead therefore of awaiting the approach of an enemy, rendered arrogant by a successful warfare of four years, he resolved to confound his powerful antagonists by attacking them as they rode at their anchors. For this purpose, he put to sea, on the 14th of January 1782, and having embarked Gen. Prescott and 700 soldiers—all that could be spared from Antigua—expeditiously bent his way, with a force of twenty-two sail of the line; of these several were crazy, and six were of 64 guns, mounting only 24-pounders on their lower decks.

On the night of the 23rd, as the fleet was sailing before the wind, the *Nymph* frigate most improperly hove-to, right a-head of the starboard division. The *Alfred*, which was the leading ship, not perceiving or expecting such a lubberly proceeding on the part of the frigate, had almost cut her in two before any preventive measures could be adopted. This accident sorely galled the ardent feelings of Sir Samuel; but it is more than probable, that like the shower on the bow of the robber, in the fable, it was a providential mischance; for an engagement with the French fleet at anchor, might have produced a disastrous result. At day-break, on the 24th, the signal was thrown out, to form the line; but the squadron was obliged to lie-to, throughout the day, to effect the repairs of the *Alfred*. This delay induced the Count de Grasse, who was nowise deficient in courage, coolness, or conduct, to quit his anchorage towards evening, and stand into the offing, that his ships might have full room to act, and thus secure the advantages of their superiority in point of numbers. His force was no less than twenty-nine sail of the line, of which the majority were the finest vessels in the world.

Early on the 25th, the French fleet were formed in close order of battle, on the larboard tack, and about three leagues to leeward. Hood, whose promptitude always equalled the urgency of the occasion, instantly perceived the advantage he could take of this movement; and in order to ensure it, made every demonstration for immediate encounter, by several baffling evolutions, which had the effect of perplexing the enemy, and driving him still farther to leeward. Yet it was an anxious suspense for Sir Samuel, between the hope of being able to gain the anchorage, and the probability of a compulsory battle, on very unequal terms, under sail. But the consummate spirit of the hero, and his reliance on his companions in arms, supported his firmness; and his high feelings cannot be better portrayed than in his official report. "Would the event of a battle," he writes, "determine

the fate of the island, I would without hesitation have attacked the enemy, from a knowledge of how much was to be expected from an English squadron, commanded by men, among whom there is no other contention, than who should be most forward in rendering service to his King and country; herein I placed the utmost confidence, and should not, I trust, have been disappointed."

About one o'clock in the afternoon, the French had dropped to a considerable distance, in hopes of profiting by the usual change of wind, when, watching the decisive moment, the British Admiral filled, rounded Nevis so closely, that the enemy could not get within him, and pushed at once for Basseterre roads. It does not appear that Count de Grasse, wary as he was, had the slightest conception that so inferior a force would attempt to occupy his situation; but quickly perceiving the excellent feint which had been practised, and apprehensive that all communication with his army would thereby be cut off, he adroitly tacked the whole fleet together, and made a most furious assault on his sagacious opponent. Not at all disconcerted, the English ships anchored in their proper stations in Frigate Bay, with the sailor-like precaution of dropping their anchors so close to the edge of the bank by which the road is formed, that the French could not bring up outside of them. We cannot but here submit Capt. White's delineation of the affair.

"Their van ship boldly advanced towards the *Barfleur*, who reserved her fire until the brave Frenchman approached within musket-shot, when she opened such a well-directed and quickly repeated fire, that in a few minutes, the French ship had her jib-boom shot away, her sails nearly cut into ribands, and her rigging so cut up, that she quickly put her helm a-weather, and bore away from her redoubted antagonist.*

"De Grasse, perceiving an opening in our line between the *Canada* and *Prudent*, in consequence of the inferior sailing of the latter ship, boldly attempted to sever it, and thereby cut off the *Prudent*, *Montagu*, *Alfred*, and *America*; but *Cornwallis*, with his accustomed promptitude, threw his after sails a-back, and thereby placed him in the breach, which he so nobly defended, that his gigantic opponent was glad to relinquish the hazardous enterprise, either through apprehension of himself being cut off, or of the *Ville de Paris* getting a-ground, should the attempt be persevered in.†

"The gallant conduct of Capt. *Cornwallis* was immediately followed by *Commodore Affleck* in the *Bedford*, and *Lord Robert Manners* in the *Resolution*, who also threw all a-back, by which, time was given to the *Prudent* and *Alfred*, &c. to recover their relative position in the line, and other ships of the enemy, of easier draft of water than the *Ville de Paris*, were prevented from attempting to break through the interval occasioned by the *Prudent's* bad sailing. *Sir Samuel Hood* looked on undismayed at this attack upon his rear, knowing that he could confide in every individual *Captain*; and very coolly ordered the signal to be made for the ships a-head to make more sail, in order to hasten their anchoring as much as possible. In

* "A tolerable proof of the dexterity of our seamen in the use of the great gun, although then unassisted by locks or sights, to aid their aim or accelerate their operation."

† "I have been informed by a brother officer who was in one of the ships that had just anchored, that for a moment he could perceive the *Ville de Paris's* jib on the inside of the British line. Had our fleet been situated as represented by *Mr. Clerk* and *Rear Admiral Ekins*, in their extraordinary plates of this action, the above four ships would have been cut off."

the mean time the *St. Alban's* had taken up her station, and anchored at 3 P.M. just within Green-point, but not quite so near to it as was intended, and the other ships did the same in succession, while the centre and rear were closely engaged with the enemy, who pressed them close until every ship was anchored,* when the French wore in succession and stood out to sea, where we will leave them to their own reflections for the present, that the true position of the British fleet may be exhibited to the view of the reader, who, if his knowledge of it has been only obtained from the works and plates of Mr. Clerk and Rear-Admiral Ekins, can have no idea whatever of its actual position.

"In the first place, instead of anchoring nineteen ships in a straight line, as by these writers they are most unaccountably represented, having the *Alfred*, *Canada*, and *Resolution*, placed at a right angle thereto, and a-breast of the centre ship in the British line, where they could have been of *no earthly use*, and would have been exposed to the enemy's fire without the possibility of returning a shot, and could not have contributed to prevent the French fleet from anchoring close to the town of Basseterre, Sir Samuel Hood in the most *judicious* and *seaman-like* manner, anchored his ships in an irregular curve from the head-most ship to the twelfth in the line, whence, in conformity with the edge of the bank, the line assumed the form of a semi-crescent, without the slightest interruption from the first to the last ship in the whole line.

"But before I proceed further, it will be necessary to observe that the Admiral, perceiving the *St. Alban's* had not anchored near enough to the shore, ordered the *Bedford*, *Russel*, and *Montagu*, from the rear to anchor a-head of that ship, which effectually shut out the approach of the French fleet in that direction."

By these tactical developments the British line was effectually prevented from being doubled with impunity, at either extreme; nor could the enemy assail it, except while under canvass, when our ships, from having springs upon their cables, could concentrate or diffuse their fire according to exigencies: a mortifying lesson to *De Grasse*. Several of our men-of-war were considerably cut up by the incessant fire of the French, particularly the *Prudent*, whose wheel was shot away, and rudder choked by a shot which had lodged between it and the stern-post, whence her loss exceeded that of any of her companions. A judicious order was then promulgated, which was, for every ship to repair her damages in the night, that the enemy might remain ignorant of the extent of injury sustained.

Not yet discouraged, though astonished and mortified, *De Grasse* ventured two more desperate but ineffectual attempts to make an impression: and here again we are happy to quote a spectator.

"On the morning of the 26th, at half-past eight, the French fleet was seen coming, as close as possible, round *Nevis Point*, in compact and regular order, intending to attempt a passage between *Green Point* and the *Bedford*, now the headmost ship in the British line. But, so singularly felicitous was the position taken up by the British Admiral, that when the enemy's leading ship † approached *Green Point*, the wind headed her, so that she could not fetch above the third ship in our line. The springs of our van ships were so admirably attended to, that the broadsides of four of them were brought to bear at the same time upon the unfortunate Frenchman,

* "The moment each ship struck soundings on the edge of the bank, she immediately anchored—how then could the French fleet have anchored without them?"

† "Supposed to be the *Pluton*, whose Captain gave during the war repeated proofs of valour."

and were opened with tremendous effect, when the wind headed him, which it did when he got the length of Green Point.

“ The crash occasioned by their destructive broadsides was so tremendous on board the *Pluton*, that whole pieces of plank were seen flying from her off-side, ere she could escape the cool concentrated fire of her determined adversaries. This ship being more distinctly marked as she proceeded along the British line, received the first fire of every ship in passing. She was, indeed, in so shattered a state, as to be compelled to bear away for *St. Eustatius*; it was even asserted that she struck her colours, but that was denied on their part. The French ships generally approached the British van with more caution, and bore away sooner than their leader had done, with the exception of a few, among whom the *Ville de Paris* was one. *De Grasse*, in order to prolong the individual encounter as much as possible, counter-braced his after-yards, in order to retard his ship's way through the water while running with the wind on the starboard quarter, along the British line. But as he hauled to the wind in rounding the British rear, where it formed the inner horn of the crescent, these sails, from becoming more a-back, detained the French Admiral a considerable time a-breast of the *Resolution*, *Prudent*, *Canada*, and *Alfred*, in succession, as the *Ville de Paris* slowly forged a-head, and fired upon them: in this *De Grasse* was supported by those ships which were a-stern, or immediately a-head of him. During this short but tremendous conflict between the respective combatants, in that part of the *field* of battle, nothing whatever could be seen of them for upwards of twenty minutes, save *De Grasse's* white flag at the main-top gallant-mast-head of the *Ville de Paris*, gracefully floating above the immense volume of smoke that enveloped them, or the pendants of those ships which were occasionally perceptible when an increase of breeze would waft away the smoke that had screened them from our ardent gaze.

“ In the afternoon of the same day, the French made a second attack on our line. It commenced at fifty minutes past two, and was principally directed against the centre and rear—the morning attack having convinced them that the British van was not to be assailed with impunity.

“ The damage sustained by the enemy's fleet was of that nature, that when they stood towards us the next day, men were seen over very many of their ship's sides, for the purpose of stopping the numerous shot-holes that were very visible. And the *Ville de Paris* had received some between wind and water, so low as to be obliged to be heeled at least three streaks to windward when standing off on the larboard tack, she having engaged on the starboard side in the three attacks, above described.”

The enemy's fleet, which received a strong reinforcement from France, under the *Marquis de Vaudrevil*, made frequent demonstrations of attacking, but never went near enough to engage. Meantime every attempt was made to relieve the fortress of *Brimstone-hill*, but without success. The enemy prosecuted the siege, with unabating vigour, till the 13th of February, when a practicable breach being made in the works, and no hopes of succour remaining, *Brig-Gen. Fraser* reluctantly consented to capitulate.

From this misfortune, the situation of the British squadron became useless and dangerous; not only from the vast superiority of *De Grasse*, but also because the French army were constructing gun and mortar batteries on a hill commanding the anchorage. In this dilemma *Sir Samuel* displayed his usual tact, by issuing orders to the respective captains to slip or cut their cables, without signal, at 11 P.M. on the 14th, the sternmost and leeward most ships first, and so on in succession; then to proceed under easy sail, till otherwise

directed. That this order might be punctually obeyed, the captains were desired to set their watches by the admiral's time-piece. The whole was performed with the utmost silence and regularity; nor were they molested by the French fleet, which was lying within five miles, and must have witnessed the manœuvre.

In these recitals, we have merely intended to mark our dissent from the arrogant pretensions, and special quibbling, of the so called "Athenians"—marshalled under the learned and logical *Dean* of the *Faculty*: but lest what we have uttered of Mr. Clerk should be misconstrued into undue disrespect for his actual judicious qualities, we subjoin with real pleasure, the following candid eulogium on Hood's measure, from his "Essay on Naval Tactics."

"Sir Samuel, disappointed in his intended attack, but confident that the obtaining a communication with, and supporting the same, was the only chance left him of saving the island, by a daring stroke in seamanship, seldom before this time attempted, in the face of this enemy, and even while in the act of sustaining a furious attack from the enemy, brings his fleet to an anchor, in the self-same position, or station, which they but a little before, and with a fleet so very much superior, had quitted, as thinking it untenable.

"On the part of the enemy there were here no accidents, which, as in all other former cases, might be laid hold of, and held up as an excuse for want of success; nothing from winds, tides, or blowing up of particular ships; not the loss of a single mast or yard; to furnish the shadow of an excuse, either for quitting their anchorage, or, after they had, for not overpowering with their numbers so inferior a fleet, occupying and even fixed to an anchorage, and affording an equal opportunity of being attacked for twelve successive days.

"On no occasion whatever has one, and the same fleet, been so fortunate, as in this of Sir Samuel Hood forcing their opponents to so complete and unequivocal acknowledgment of their superiority in both cases, whether we shall consider their courage and perseverance, or their skill and seamanship."

We now approach the close of our Author's work, where the exploits of Rodney are related—exploits which have been so frequently fought and refought, that we should have had some doubt as to the necessity of our proceeding further, but that the authoritative and illusory tone of the "leading Journal" prompts us to show that, however it may "preach to the marines,"—its splashing and floundering are laughed at by sailors. We also object to the invidious strain in which the "blue and yellow squad" mention the claims of their clans-men in general, as tending to make a distinction where there is scarcely a difference. For ourselves, and we believe we may add for the majority of the United Service, we trust that England and Scotland may row together, with a long and strong pull, to the end of time; and we see with gratifying pride, that this opulent and potent country is capable of having such numbers of her Northern brethren billeted upon her. With Newton, Bacon, Locke, Shakspeare, Milton, Nelson, Marlborough, and other first-rates in abstract science, knowledge of nature, and eminence in arms, she can easily permit the stars of "Athens" to fall into the British line of second and third rates;—nay more, we can even make accommodation for most of the heavy transports, repeaters, and small craft, composing the "absolute wisdom" of the North: nor need the proudest names which blazon the Caledonian annals blush to

be coupled with our Halley, Flamstead, Young, or Davy; our Dryden, Pope, Addison, Fielding, or Byron; our Talbot, Clive, or Peterborough; our Drake, Blake, Raleigh, Hawke, or Howe.* Indeed, had not such a kindly feeling been extensive amongst us, "Athenian" talent could not have flourished so luxuriantly; for what would the immaculate REVIEW have been, but for English purchasers and English writers?—or what would have rewarded "Athenian" labourers in general literature, had they gained no readers south of the Tweed? With such palpably liberal ideas on the score of nationality, we entertain no doubt of being heard with complacency, by all hands. We therefore beg to avow, that, looking upon "breaking the line" as an evolution which has ever been practised where it should be, we cannot but smile at the gravity with which Playfair, Jeffry, Walter Scott, and other redoubtable civil *land-o'-cake-men*, claim the naval glories of the nation, for an abstract book of t'other day. On the contrary, from every testimony gathered together in a life mostly passed at sea, we verily believe that on the memorable 12th of April, this "*magnificent invention*" was put into practice at the suggestion of Sir Charles Douglas; though we are also "free to confess," that the occasion resulted from mere accident. And "we do further declare," that, in our opinion, there is little merit in breaking the enemy's line, *unless circumstances both demand and favour it*, as in that successful instance. With this preliminary explanation, we shall proceed to give a general view of the importance of the contests, and afterwards cite the evidence of Capt. White, he having been an actor in the scenes which he describes.

After the fall of St. Kitt's, Great Britain retained, of all her former West India possessions, only the islands of Jamaica, Barbadoes, St. Lucia, and Antigua; and of the possibility of preserving these, great doubts were entertained. Jamaica in particular, which had been frequently threatened, now appeared to be in greater danger than ever: for, whilst the Comte de Grasse was riding superior in the Caribbean Sea, the Spaniards were in great strength at Cuba and Hispaniola; and the fleets of the two nations, if combined, would have consisted of no less than sixty ships of the line; while their land forces would have constituted a powerful army.

It now only remained for us to force a battle with the French, before they should form a junction with the Spaniards at Hispaniola. Our fleet accordingly laid in wait at St. Lucia, having stationed active out-scouts to report the enemy's movements in Port Royal Bay. On the 8th of April, 1782, the glad tidings were signalized, that thirty-four sail-of-the-line, two fifties, several frigates, and a large convoy, were sailing close under the islands;—tidings which were received with the most animating cheers. In fact, so prompt were our zealous tars, that the Count was overtaken that very night, off Dominica. Such a sudden attention was as little expected by the French Admiral, as it was unwelcome; but he lost no time in accommodating himself to the emergency; and early on the morning of the 9th, formed the

* It is a singular fact that all the Flag Officers, in the battles alluded to, were Englishmen.

line of battle to windward, to afford his convoy an opportunity of proceeding on its course.

Meantime our fleet was becalmed under the land, till about half-past seven, when the van division caught the breeze, and though the centre and rear continued without wind, Sir Samuel Hood pursued fourteen of the enemy's ships with only eight of his own division. A French straggler which got the breeze at the same time, boldly stood for, and endeavoured to weather the British advance, as the only means of regaining her own fleet. To such a length did she carry her audacity, that she compelled the Alfred to bear up out of her way! As soon as she had got beyond the reach of the *Barfleur's* guns, she hoisted her colours, and hauled up her lower-deck ports. Every eye was fixed on the gallant Frenchman, and each of the ships she passed were ready to "let slip the dogs of war;" but such was the discipline in the fleet, that, as Rodney made no signal to engage, not a shot was fired at her.

At half-past nine, De Grasse impetuously attacked our dashing division, which sustained the disproportionate encounter with inflexible resolution, for upwards of an hour; during which the *Barfleur*, Sir Samuel's own ship, had at one time seven, and generally three ships, pouring in their fire at once. His captains crowded under a press of sail to support him; amongst the rest was the *Royal Oak*, whose crew, while passing under his lee, filled the lower, topmast, and top-gallant rigging, to give their Admiral three hearty cheers. These are the bursts of feeling which attach us to the Service!

The wind now gradually reaching the centre, Sir G. Rodney, in the *Formidable*, followed by his two seconds, the *Namur*, and *Duke*, all of ninety guns, opened a tremendous discharge; when De Grasse, to prevent the fight from becoming decisive, availed himself of his command of the wind, to retreat to his usual long-shot distance. The rear was coming up fast, but the cautious Frenchman had withdrawn his fleet, and eluded all the efforts of the English commander to renew the action. The enemy appear to have received much more damage than they produced to their opponents, and two large ships were so much disabled, that they were obliged to run for *Guadaloupe*. On our side, the effect of the fire was serious, and amongst others, Capt. Bayne, of the *Alfred*, gallantly lost his life, in this, his sixth encounter with the same antagonist.

Capt. White, after giving De Grasse great credit for his seamanlike attack, of which it seems neither Clerk, nor Rear-Admiral Ekins had had a clear conception, remarks,

"From what has been said, the reader cannot, I should think, arrive at any other conclusion than this—that no advantage was offered in that day's battle, to either the centre or rear division of the British fleet, that they did not avail themselves of to the utmost of their power; and it is beyond a question that Sir George Rodney, had his wily enemy given him the opportunity, would have cut in between the ships engaged with Sir Samuel Hood's division, and the rest of the French fleet, which but for his approach would have continued to make the circular attack on the British van division.

"It is too frequently the case in the accounts given of naval transactions which are compiled by landmen, and perhaps naval authors themselves are not altogether exempt from the defect, that sufficient allowance is not made for the difference existing between different ships of the same class, and

consequently one ship is considered by their readers as good as another. This relative difference between the ships composing the fleets of France and England seems to have been completely overlooked in all the narratives which have reached us of the events in question, although a due consideration of it is so necessary to a correct view of the movements of the respective fleets. The French naval architecture had attained a degree of excellence in the construction and capacity of the ships of that nation, which gave them serious advantages over us in point of sailing, either on a wind, or going large; and from their having a greater depth of hold, they possessed a decided superiority in the most essential point of keeping a better wind. The fineness of their construction gave them important facilities in smooth water; hence in a fine weather climate, where nautical skill is not so frequently required as under our inconstant sky, and on our more boisterous ocean, they could at all times either commence or avoid close action at pleasure; hence also the facility with which they got away to windward of our fleets when they no longer wished to engage; and most likely had it not been for the accidents which happened to some of their ships, in consequence of the battle of the ninth, Sir George Rodney might not have been able to overtake the fleet of the enemy, even had both been equally in possession of the breeze."

Both parties had full employment that night, and the following day, in repairing their damages; yet our ships neglected no endeavour, notwithstanding their inferior knowledge of the locality in which they were working, to get to windward of the enemy, but without success; so determined was the latter to avoid a renewal of the contest. Meantime, most of the disabled vessels got tolerably refitted: and to promote efficiency, the order of the line was inverted, by which the rear under Admiral Drake, which had no share in the action of the 9th, became the van.

On the 11th, the enemy had gained such a distance, that the body of the fleet could only be discerned from the mast-head of the British centre, when two of their damaged ships were perceived to fall off from the rest to leeward. A detachment now pursued them so vigorously, that they would necessarily have been cut off, had not De Grasse borne down with his whole force, to their rescue; but having perceived that their retreat into Basseterre roads was effected, he again hauled his wind. This accident, however, had scarcely been eluded, when another occurred, which proved more effectual, for during the night the *Zélé*, a French seventy-four, lost her foremast and bowsprit, a circumstance which impeded the progress of their fleet, and was the immediate cause of the general engagement that ensued.

On the morning of the glorious 12th of April, four ships having been sent in chase of the *Zélé* and the frigate which was towing her, De Grasse edged away to induce their recall. But Rodney, who always acted upon the decision of the understanding, and not from impulse, formed his line, and having met the hostile fleet on opposite tacks, threw out the signal for a close action—a signal which every vessel obeyed with scrupulous alacrity. The scene was an extensive basin, bounded by the islands of Guadaloupe, the Saintes, and Marie Galante, with dangerous shores, both to windward and to leeward. The British line, instead of the usual interval of two cables' length between every ship, was formed at the distance of only one. As each came up, she ranged close under her opponent's lee, giving and receiving, while thus taking her station, a most tremendous cannonade. Drake's divi-

sion forming the van, was led by the Marlborough, which vessel miraculously received and answered the broadsides of twenty-three men-of-war, at the nearest distances, with the loss of only three killed, and sixteen wounded. As the Hercules ran alongside of an antagonist, of far superior force, her captain coolly jumped on an arm chest, and cheered up his men by gaily singing a few lines of

“ O what a charming thing’s a battle !”*

The action was thus commenced at half-past seven o’clock, and in about two hours the whole of our fleet, from van to rear, was engaged. The fight was most obstinately maintained on both sides ; and from the number of troops crowded into the French ships, the carnage in them was prodigious.

We now approach a perplexing moment—one which is really the very *pons asinorum* of naval battles ; viz. “ on what manœuvre the fate of the day turned ?” Our own judgment rather cuts than disentangles the knot : it bears strongly to the simple statements made long ago by Beatson and Matthews, confirmed by Capt. White, and corroborated by oral evidence, of frequent recurrence in sea life. From such testimony it appears, that the derangement in both lines, and the opening which Rodney found his ship in at ten o’clock, were occasioned by change of wind *alone*—this it was that broke both fleets into three unequal portions, instead of being *cut in twain* according to Clerk’s system ; and all things considered, it may even be doubted whether availing himself of it was a really fortunate occurrence. But we differ from Capt. White in its being a heinous offence for so confidential an officer as the Captain of the fleet to advise his Admiral on points of service, it being his express duty so to do ; or that expostulation between such official friends need be under the terror of the Articles of War. We have constantly heard in the navy, that the prompt and murderous use which the Formidable made of her position, however gained, was owing to the advice of Sir Charles Douglas “ on the spur of the moment ;” and we certainly see nothing inconsistent, disrespectful, or derogatory to the Admiral in the transaction. We can also assert without fear of contradiction, that they were both men, whose heads were rather replete with profound professional knowledge, than turgid with visionary theories. We beg moreover to repeat, that we have never heard any sound seaman advocate the Eldin story :—as well might Dr. Eady, or any other notorious quack, claim the improved health of the British metropolis, as owing to his advertisements.

Whatever created the disorder and confusion, victory was not the immediate consequence. On the contrary, the action continued till dark, and the enemy fought with courageous firmness ; each of the ships which struck, had been defended to desperation, nor did De Grasse lower his flag, till 400 of his crew had perished, and only two

* The highly exhilarating effect of incidents of this nature, at such a moment, and the additional confidence reposed in the commander, can scarcely be imagined but by those who have felt the proud glow. It is said that when Admiral De Winter’s fleet was being closed, off Camperdown, Duncan laconically addressed those around him with, “ Gentlemen, you see a severe *Winter* fast approaching ; I have only to advise you to keep a good fire ;” a pleasantry which spread over the Venerable like wild-fire.

men besides himself were left unhurt on his quarter-deck : a different combat to the *piſſ-poff* predicted by M. Maurepas.

“ Record it in the faireſt light
Of faithful hiſtory’s page ;
They only triumph’d whiſt they ſhunn’d the fight,
We, when we forced them to engage.”

We would fain dwell longer upon the details of this brilliant action, but that Capt. White’s clear ſtatement ought to be univerſally read ; and that we hope a full account of the battle will be produced by Sir Howard Douglas, whoſe talent and competent knowledge of the ſubject can furniſh a full expoſition of its merits, and give a *quietus* to the queſtion. Though we wiſh not to ſpoil the intereſt of the Captain’s “*Reſearches*,” by making copious extracts, we cannot but ſubjoin the following pointed reflections.

“ I have alſo, I truſt, ſatisfactorily ſhown that the battle of the 12th was brought on by the French Admiral having borne up before the wind for the purpoſe of affording protection to the diſabled French ſhip *Le Zélé*, and not by the British fleet having ſtood to the ſouthward till two in the morning, as is moſt unaccountably ſtated in Sir George Rodney’s public letter, and repeated by Mr. Clerk and Rear Admiral Ekins in their deſcription of this engagement.

“ I have not allowed myſelf to be biassed by any conſideration but facts, in bringing forward the ſtatements I have ventured to lay before the public. On this principle alſo I have endeavoured to place in its due light, the ſo much vaunted measure of breaking the enemy’s line. The boldeſt aſſertors of the claims of Mr. Clerk to the honour of this celebrated diſcovery, have not yet preſumed to enumerate Commodore Affleck, of the Bedford, among his pupils, and yet it is true, that the Bedford, as well as the Formidable, made her way between two of the enemy’s ſhips, but in a different part of what is called their line of battle. Owing to this circumſtance the French fleet was, as has been already obſerved, broken into three parts inſtead of two as is commonly imagined, though we do not find that the gallant Affleck took any ſhare of merit for achieving an exploit preciſely ſimilar to that which has been bruted with ſo much induſtry from John o’ Groat’s houſe to the Land’s End. The victory of the 12th of April, however, was ſo far from ariſing from this movement either of the Formidable or the Bedford, that the circumſtance of the diſjointed parts of the British line getting between equal portions of the enemy’s fleet, produced only the effect of allowing ſeventeen or eighteen ſail, to avoid the cannonade they muſt have encountered in weathering the ſhips of the British rear, which they muſt have done had they had to paſs our whole line. How far they would have ſucceeded in doing ſo is another queſtion, but the ſtrong probability is, that had they, in the ſtate in which they then were, been expoſed to this additional ordeal, they would have ſhared the fate of their five captured comrades. It ſeems evident then that we muſt aſcribe the victory, under Providence, to the circumſtance of the contending fleets being brought into cloſe combat by Sir George Rodney tacking at the preciſe moment he did, and by a ſubſequent change of wind. This poſition gave to our brave countrymen an opportunity of exerting thoſe qualities which are the reſult of firmer nerve and cooler courage, while it deprived their enemy of the advantage he was generally ſo fond of deriving from his ſuperiority in ſailing, and conſequentially in manœuvring, of which he availed himſelf whenever he could fight at long-ſhot diſtance.”

It were unjuſt to diſmiſs this article without a parting word. In ſtudying theſe encounters, it is impoſſible to overlook the admirable

discipline and fighting order which must have pervaded our fleets, to enable them to sustain so harassing a warfare; while the destructive havoc dealt to the enemy, proves that naval gunnery was more effectively plied then, than it has been latterly; owing, perhaps, to the remissness arising from constant success. On the other hand, the very defective state of our ships in those days, is frequently dwelt upon in the "Researches," as an evidence of what kind of tools the British Admirals had to work with; and to enable the tyro to form a more correct judgment on the exertions of the officers of that day—the "old school" of our Bobadils—than other productions afford him the means of doing. Through the misconduct of our Ministers, the advantages we gained were isolated, and the result of the war unfortunate, for they did not seem to be aware, that to attempt an object with smaller means than we can command, is a profligate waste of life and treasure. Thus, though it was well known that the French were about to make the West Indies the theatre of war, they were always allowed to outnumber us; and the best ships we had, were carefully preserved in England. We therefore esteem it as one of the grand causes of Rodney's glorious success,* that he had more efficient means at his disposal than his predecessors. Another inference we gather is, that a true-bred tar was then, as now, and we hope for ages to come will continue to be, the merry, dare-devil, happy-go-lucky being, we have always found him when, as he says, "there's any thing for a fellow to do." Of the gallant recklessness of sailors, in the proud moment when the flag of their country is displayed to an enemy, the testimonies are universal: Nelson was wont to say, "They mind shot no more than peas;" and to their intrepidity Lord Howe attributed all his success. But for their unwearied zeal, whether braving the Pole or the Equator, England must inevitably have tasted of the horrors of war at home, instead of participating in every domestic comfort, while scenes of blood and terror were afflicting all the surrounding nations.

French sailors are also unquestionably brave; but their bravery being an affair of mere impulse, is more frequently manifested by impetuosity of attack than fortitude in defence. We wish to avoid the charge of prejudice, but from closely studying their own reports of battles, breezes, and wrecks, we can pronounce that, though *Crapaud* is more buoyant in success than *Jack*, he is more dejected under reverses; and he altogether yields to the Briton in that resolute courage which instantly applies resources against impending danger.

Futurity is inscrutable—but is such a matchless display of human art as a Grand Fleet, in line-of-battle, together with all the patriotic daring and practical energy of British sailors, doomed to succumb to some gigantic wedge, propelled, under the direction of a dozen stoakers, by a few chaldron of coals? Ohe!

* In commenting upon this memorable battle, we have felt, as we hinted above, the want of more positive *data* respecting the most important feature of the contest, viz. the real cause of the opening in the enemy's line, and its direct consequences. We understand, however, that Sir Howard Douglas is furnished with tangible evidence on this head, and we shall look to the final statement of that accomplished and patriotic officer for *proofs*, if such exist, to influence our decision upon a point still susceptible of doubt.

RECOLLECTIONS OF THE LATE AMERICAN WAR.

BY A CRUISER.

It was at the commencement of the month of January 1815, that a squadron of frigates and smaller vessels, with a line-of-battle ship, (the Dragon of 74 guns,) were assembled off Amelia Island, situated at the entrance of the river St. Mary's, in South Carolina, for the avowed purpose of capturing the town, and merchant-vessels lying off it, nearly thirty miles distant from the sea. Capt. Somerville, of the Rota frigate, was the senior officer of the squadron, but in consequence of having been confined to his cot for several months by severe illness, he delegated the command of the expedition to Capt. Barrie of the Dragon. The ships' boats, manned and armed, (with a party of marines in each,) were dispatched to the rendezvous at Amelia Island, where several companies of the West India Rangers (who are all blacks) were already assembled. Point Petre, which forms the starboard entrance of St. Mary's river, was distant from us about four miles, and was very strongly defended by a battery mounting six long thirty-six pounders; added to which a strong and rapid current constantly prevailed, setting from this point towards Amelia Island, at the rate of more than two knots an hour.

We remained several days encamped upon the island, making every preparation to storm the fort, (if necessary,) and also with a lingering hope, that the wind which had hitherto blown dead in our teeth, would shift to a favourable quarter: in fact the weather was occasionally so rough and squally, that it was with considerable difficulty the boats could maintain their position at anchor during the night, their light grapnels being insufficient to prevent their drifting, and consequently every expedient was resorted to, by sinking heavy iron kettles laden with stones, &c. to effect this purpose; but notwithstanding these efforts, our Lilliputian fleet, amounting to upwards of fifty sail of "small craft," would on the morrow's dawn frequently present rather a confused and scattered line. Our launch, which pulled eighteen oars, and mounted an eighteen-pound carronade forward, a brass four-pounder abaft, with two swivels on each side her gunwale, cut rather a formidable appearance among the host of pigmy satellites by which we were surrounded; and it was laughable to observe how frequently the pressing calls of hunger would relax the haughty bearing of military rank, for we had the advantage of possessing a very compact set of coppers and cooking apparatus that had been taken out of a small schooner we had captured and burnt a few days prior to our arrival, which of course enabled us to provide a sumptuous meal in comparison to our less favoured brethren. From this circumstance it may be surmised, we had generally a pretty strong muster at our dinner hour, and many a gallant captain, when pulling past us in his gig, could not resist the temptation of the savoury steams acting upon his olfactory nerves. He would lie upon his oars, and hailing our "luff," demand what we had for dinner, then without ceremony step into our boat, sit down, and with as much *gout* as if in a club-house at St. James's, help to demolish a huge assemblage of lobskous, composed of stewed geese, fowls, salt junk, &c., the feathered part of the re-

past being neither very delicately drawn nor plucked; however, hard service created a good appetite, and a-glass of grog, with agreeable companions, served to render a meal truly delicious and acceptable, that under other circumstances an epicure would have turned from in disgust.

In after-years, when fondly dwelling upon the early scenes of my boyish days, how often have I reflected into what artificial beings the habit of luxury has moulded us—when tossing, wearied, and feverish on a bed of down, how often have I brought to mind the delicious slumber I have experienced in the bottom of a boat, with nought save the canopy of heaven for a covering, even when the warring elements were pouring down a deluge of rain upon my weakly frame:—so true it is, that the real comforts of this world can only be felt and duly appreciated by those who have been enabled to form a just comparison between the superfluity of wealth, and the miseries of deprivation!

The evening before the intended attack displayed a most imposing and enthusiastic scene; the arms of the marines and soldiers were piled in fanciful groups, whilst their gallant owners, indiscriminately mixed with the seamen, were reclining around the large fires which were kindled at various distances, (they having taken the liberty of cutting down sundry huge trees to make a blaze,) and all hands were drinking their grog, and singing in full chorus the burthen of our beautiful national airs, *Rule Britannia*, &c. until the very woods reverberated the echoes which rung from the iron but loyal throats of the assembled throng. The splendour and beauty of the passing scene, might even have tended to inspire the veriest craven upon earth, “to screw his courage to the sticking point,” and at least become a hero in imagination.

At length it was fully determined to wait no longer than the morrow's dawn for the destined attack of the fort, which commanded the entrance of the river. Still, as the wind continued to blow very hard, it was doubtless rather a perilous enterprise; however, by eight o'clock in the morning, the boats were formed into three divisions: the van being composed of a very large barge, pulling twenty-six oars, (named the *Snap Dragon*), bearing the Commodore's pendant, the *Dragon's* launch, and our own, whose force I have previously stated: then came all the barges which mounted carronades, and the remaining cutters, jolly-boats, &c. brought up the rear. The whole of this force was flanked by those distinguished officers Captains *Barrie* and *Jackson* (of the *Lacedæmonian*), in their respective gigs. The *West India Rangers* and a party of marines had been already landed to attack a portion of militia that had been stationed in a wood for the defence of the fort on shore. I need scarcely state, that when the arrangements were completed, and the wished-for orders given to start, every nerve was strained, every sinew put in requisition, to endeavour to reach the wished-for goal as speedily as possible. But still our progress was tedious and disheartening in the extreme—the breeze was strong, and the current rapid; when however, by dint of incredible exertion, our three headmost boats approached within point-blank range of the battery, they opened upon us with their heavy artillery, and as the men responded with a hearty and deafening cheer to the well-known salutation of their officers, “Give way, my lads!” the shot whistled over our heads, or splashed our faces with the spray of the sea as they fell into the water.

In this pleasant predicament, we continued several minutes, and had the Americans persevered, they must inevitably have sunk one half of the invading force; but when we approached within half a mile, volleys of musketry were heard in the direction of our troops, and the enemy, no longer waiting to be assailed in their strong hold, hauled down their star-spangled banner, and fairly took to their heels. A general cheer was now given by our seamen, who made a simultaneous effort to be foremost in getting ashore to plant the Union Jack on their fort. The guns were quickly spiked and dismantled, whilst orders were issued to make the best of our way up to the town. In the mean time, our soldiers and marines had a smart skirmish with the American militia, who were speedily routed; but I was informed, that it was with the greatest difficulty the officers of the West India Rangers could curb the rancour and animosity their men bore to the name of an American: they did not exactly comprehend the system of giving quarter to a conquered foe, especially as numbers of them had been held in bondage from infancy in this country, and many an unfortunate Yankee that fell into their hands in the woods narrowly escaped being butchered in cold blood.

Notwithstanding every exertion, we did not reach the town until past midnight, and found that it had been taken possession of without striking a blow; most of the inhabitants had quitted their residences for the country, taking with them their most available effects, and in the morning it bore a melancholy aspect. Valuable furniture of all description was scattered about the streets in profusion; the majority of the doors were left standing open, while occasionally a few stray citizens might be discerned, whose habitual anxiety for the riches of this world overcame the fear which was strongly depicted in the countenances of those who remained to guard them. Heaven be praised! the inhabitants of our happy nation are ignorant of the desolation and horror of warfare carried into the heart of a peaceful country: they cannot appreciate the riven feelings of him who is driven from his home a wretched wanderer upon the face of the earth. The Commodore was most anxious that private property of every description might be respected, and held sacred from depredation; but he had a bounden duty to perform, which was to take possession, in the name of his Majesty, of every *store* containing merchandize, and a broad arrow was legibly impressed upon all such that had the misfortune to fall under that class: we also captured ten or twelve merchant vessels, one of them an East Indiaman of nearly six hundred tons. It may not be generally known, that the town of St. Mary's is situate on the north bank of the river, and that the southern shore is in the dominions of the King of Spain, consequently, many vessels had succeeded in gaining the neutral side of the river, (which is very narrow in this position,) and their crews, not a little elated with the success of their expedient, frequently taunted our men as they passed in the boats, with the most elegant sneers and witticisms to be found in the Yankee vocabulary.

Although terms were entered into with the proper authorities for the peaceable occupation of the town until the vessels were laden, very few of the inhabitants could be induced to return to their dwellings: in deep and striking contrast to the melancholy gloom which per-

vaded the streets, on the quay all was life, soul, spirit, and activity. Jack was really and truly in his element, lading American ships with American property in the heart of their own country, and it would have provoked the risible faculties of the most saturnine philosopher to have observed our seamen at the conclusion of each meal, with the characteristic thoughtlessness of their profession and general aptitude for a lark, toss the fine china plates and dishes into the river with the most provoking wantonness and nonchalance, not caring for the trouble of cleaning their culinary articles, when so many large china stores stood most invitingly open to furnish a fresh supply: during the portion of time allotted to our meals, I frequently wandered through this beautiful little town, and boy as I then was, could not help feeling a compunctious twinge of conscience in aiding and assisting to carry the desolation of warfare into the bosom of a district so remote from the strife and contention of the great world. One morning, taking advantage of the stowage of the vessel that I was ordered to superintend being completed, I went down to our launch and pulled off my shirt, that the boat-keeper might wash it, and whilst he was performing the process of ablution, I reposed myself quietly in the bottom of the boat, anticipating in imagination the comfort of once more enjoying the luxury of clean linen; but I had only settled myself a few minutes in this dream of enjoyment, when I was disturbed in my reverie by the Commodore hailing our boat, requesting to know where the Midshipman was; up I started like a culprit, and buttoning up to my throat to conceal my shirtless appearance, hastened to receive his orders. My pride would not suffer me to reveal the truth, so I made a lame excuse by stating I was rather unwell; he desired me to take a few hands and fill the launch with oranges from a lovely grove that stood to the southward of the town. Our men clambered the trees like monkeys, and showered down the delicious fruit in abundance, whilst I stood discomfited and shivering (although unable to repress a hearty laugh) until the sun's rays had enabled me to resume my inner garment. This little anecdote serves to show the hard rubs all ranks on service are occasionally subject to, for on quitting our ship I had not five minutes preparation to proceed on the expedition.

Every vessel being nearly completed with the motley description of merchandize found in the several stores, we received orders to make the best of our way down the river and join our ship, where, on our arrival, we found the Albion, 74, which had joined the squadron, bearing the flag of Rear-Admiral George Cockburn. Not having been in bed for more than a fortnight, I need not state that I slept for twelve hours without rocking, and heartily wished the quarter-master in the Styx when he aroused me in the morning with the unwelcome tidings that six bells had struck. To our great surprise, in a couple of days, we received forty or fifty American prisoners on board, the Commodore having detained the whole of the inhabitants who had returned to their dwellings (as hostages) in consequence of the enemy having broken the armistice by marching various bodies of troops to the relief of St. Mary's; and late in the evening we received orders to weigh and cruise between Charleston and Savannah. At this period we were excessively short of water, but acting on the maxim of old Earl St. Vincent,

"Never make a difficulty," our captain put to sea and proceeded to his destination. We soon found that no American vessels dared attempt to enter these ports, consequently there was little hope of making prizes by merely standing off and on shore; we therefore pursued the daring plan of remaining out of sight of land during the day, then at night running the ship close in, and dispatching our boats with orders to cut out any vessels that might be running down in shore of the numerous islands that skirt the coast in this part of the country. Our first essay was crowned with complete success, by capturing a flat-bottomed schooner, laden with three hundred bales of cotton and thirty hogsheds of tobacco. Emboldened by this stroke of luck, we prevailed upon the skipper of a schooner, whose vessel we had destroyed, (taking out the crew) to pilot our boats into Savannah. They reached the harbour (favoured by the darkness of the night) in perfect safety, and had succeeded in carrying a very large schooner with a cargo of five hundred bales of cotton and tobacco; the wind was very light, the oars were muffled, and their splash was scarcely discernible as they towed the vessel towards Tybec Lighthouse; every thing promised complete success, when the envious streaks of light that chequered the grey dawn in the East, betrayed our manœuvres to a large cutter lying in the harbour. The report of a gun soon alarmed all the vessels in the port, and four large gun-boats, in conjunction with the cutter, soon made all sail in chase; our prize was speedily relinquished, and our men pulled for life or death. Fortunately the wind dropped to a perfect calm and the boats soon got out of gun-shot of the enemy; but the poor Yankee skipper did not easily forget the fright that electrified his whole frame; death stared him in the face; he declared he expected they would hang him upon the spot, and most earnestly conjured our lieutenant to state, in his justification, that he was forced to enter the boat through the terror of a loaded musket.

During this cruise we had to undergo the most severe privation for want of water, and at length were reduced to the pressing necessity of putting all hands upon a pint per diem, and even this was only accomplished by breaking up our hold and starting the small portion that remained in the bottom of the tanks, which of course was mixed with a considerable quantity of mud and dirt. For several days we continued in this wretched situation; the miserable quantum of water used to be served out to each individual in the middle watch, and frequent instances occurred of the men saving their rum, which they offered to exchange for an equal quantity of this unpurified liquid, and a seaman must be hard up indeed when he will voluntarily part with his grog. Of course in this extremity the officers shared equally with the men, and it was truly heart-rending to observe with what avidity and eagerness the poor fellows seized their allowance and quaffed it off at a draught; with what anxiety we were accustomed to watch the revolving circle of time that would again present to our parched lips one solitary pint of water. Never until this period did I fully appreciate the value of a draught of that pure element which constitutes the primary support of every species in the animated creation. We began to despair of falling in with any of our cruisers to gain a supply, and therefore turned our wits to work. In every relation of life what will not resolution and perseverance effect? We dispatched the launch,

barge, and cutter, well-manned and armed (under the command of Lieut. Wentworth) on shore to the Hunting Islands, with implements to dig wells on the beach, in the ardent hope of discovering fresh water; nor were we disappointed: after much toil and trouble we succeeded in two or three places where it flowed pretty freely, although rather brackish. The cutter was immediately dispatched to the frigate with the joyful intelligence; in the mean time we anxiously reconnoitred the adjacent coast, and destroyed a small battery of two guns that fired upon us. At night we came to an anchor, surprised to find that two of our marines had deserted, and, as subsequent circumstances proved, had proceeded to Charleston, and, in the hopes of gaining a large reward, had given exact intelligence of our force. This circumstance made all hands rather uneasy, and tended to damp the flow of spirits which otherwise prevailed during each night, for sleep was out of the question, situated as we were on the coast of an enemy, with the broad Atlantic ocean staring us in the face. As the kannikin of grog flowed freely round, many a song and tale of by-gone deeds of glory enlivened our hours of darkness until the morning's dawn made us prepare for the duty of the coming day.

We were speedily rejoined by the cutter and our flat-bottomed prize, laden with tanks and water-casks in lieu of her cargo which had been taken out. She was armed with a long nine-pounder, and placed under the command of a very gallant young master's mate, Mr. James Creagh. To avoid incurring the slightest suspicion, our frigate kept at a considerable distance in the offing, so that her hull was not discernible from the shore; and we all turned to with a good will to fill the water casks, that our poor shipmates might once more enjoy the luxury of quenching their burning thirst. Every circumstance seemed to augur success; we had just completed the stowage of the casks in the launch, and were actually parbuckling the last cask on board, when unfortunately she grounded in a hollow of the beach. The tide, which was ebbing very fast, left her high and dry in the space of a few minutes, and notwithstanding the united efforts of the whole body of our seamen, we could not succeed in launching her. This was mortifying enough; but in our case the old adage was completely verified of "Misfortunes never coming single," for at this critical juncture, four large gun-boats, (each pulling from thirty to forty oars,) and a row-boat, were discovered standing out of North Eddisto Inlet, situate at the northern point of the island, and about three miles distant from the position we occupied; large parties of horse and foot, composed of militia, now rapidly advanced along the beach. All hands were instantly on the alert, our men waded through the surf into the boats, the barge received all our launch's crew, and immediately pulled on board the schooner, then about one mile to the southward and dead to leeward of us, whilst the cutter remained to spike the guns and drown the magazine; but the gun-boats advanced so rapidly that we thought it high time to regard our own safety. Fearful of our cutter grounding, Lieut. Morgan was very cautious how she came in-shore, and it was with considerable difficulty I reached her, wading up to the chin and holding a short musket in one hand and a cutlass in the other, and in this condition was hauled into the stern sheets by our cockswain.

Away we pulled right athwart the gun-boats, (now within three

quarters of a mile); they immediately opened a heavy and well-directed fire upon us, and made every exertion to cut us off. The barge perceiving our imminent danger hastened to rejoin us, and the schooner (for whose safety not the slightest apprehension was felt) saluted the enemy with her nine-pounder, firing over our heads and at the same time making all sail to join our frigate, that was now observed standing in under a heavy press of canvass, with the general recall up. In this position we continued several minutes, doubtful whether we should escape, but our gallant fellows laughed and joked as if they were engaged in a simple rowing match, or pulling ashore at Point to enjoy a glorious cruise. As the enemy neared us, and each shot that they fired either whistled over our heads or falling between our boats splashed each individual, it only gave rise to fresh mirth and a new jest at the Yankees' expense, for being such bad marksmen. At length, perceiving that we had succeeded in crossing their hawse and that our frigate was closing fast, they dropped the chase and turned their attention to our schooner, which had been strenuously endeavouring to gain protection of the ship; but as fortune would have it, the wind now fell calm and she had no alternative but to engage the whole of this unequal force, having made an impregnable barrier with some bales of cotton. At this period the scene was vivid and imposing in the highest degree; our frigate having stood into four fathoms water, hove-to and fired whole broadsides over our heads at the gun-boats, which unfortunately were just out of range of her artillery. The captain, perceiving the unequal contest to which the schooner was exposed, hauled down the recall and dispatched the first lieutenant with the remaining boats to her assistance. Immediately we perceived this manœuvre, every nerve was strained, every faculty was roused to reach the gun-boats before they should succeed in boarding our prize. We were coming up with them fast, and congratulating each other upon carrying the enemy and rescuing our shipmates, when, to our extreme mortification, the breeze freshened and we perceived our gallant young officer* under the humiliating necessity of striking his colours, having expended all his ammunition, and, as he subsequently informed us, committed his gun to the deep with the usual ceremonies. A fine steady breeze had now succeeded, and in spite of every exertion the gun-boats towed our schooner triumphantly into South Eddisto Inlet, amid the gratulations of their countrymen who had assembled on the beach to witness the engagement, while with the deepest silence and regret we pulled on board not only with the loss of our launch, schooner, assistant-surgeon, master's mate, and thirty-two men, but what was of infinite consequence, we had to regret the capture of all the water which had cost us such vast pains to procure. All this, as we subsequently learnt, was the consequence of the treacherous desertion of our two marines, the gun-boats having been sent expressly from Charleston to capture our watering party.

Notwithstanding we had now been upon this extremely short allowance upwards of a fortnight, our captain was unwilling to quit his

* Mr. James Creagh elicited the most enthusiastic praise from every officer and man who beheld his cool and determined conduct upon this occasion. It is gratifying to state that his gallantry met with due reward; he served on board the same frigate at Algiers, and at the captain's particular recommendation was promoted to the rank of lieutenant, and is now very deservedly on the list of commanders.

cruising-ground without orders, especially as we were not without a lingering hope of falling in with an American frigate, an idea being prevalent both among the officers and men that it was expected one would cross this track, and spite of our previous loss, we still imagined we might be enabled to maintain the honour of our country in the encounter; and I am confident that our gallant first lieutenant* was haunted night and day with the spirit-stirring idea: himself a most scientific and accomplished officer, he had trained our crew to a degree of skill and precision in the use of the great guns and small arms, which was rarely to be equalled, perhaps never to be excelled; the result of which was mutual confidence to an unlimited extent between the officers and crew. At length every soul on board really began to be seriously alarmed for the want of water; we had not more than one ton remaining in the ship, which, as I have previously stated, was the drainings of the tanks and casks. However, Providence befriended us.

One morning a large ship hove in sight, which we chased under all sail. When her hull became visible it was fully apparent that she was a frigate of the largest class; the private signal was made, to which no answer was returned, consequently we immediately cleared ship for action, knocked down the bulk heads, took in our small sails, and stood under easy sail for the chase, which neared us very fast. At this period of the war it was confidently surmised that the Americans had gained possession of our signals; the telegraphic code had been already changed, and little reliance was placed even on the exchange of private signals; circumstances at all events rendered it very suspicious that the chase did not answer us, and, as a *ruse de guerre*, we hoisted a large American ensign; the frigate did the same. Our officers and crew were now in that highly wrought state of excitement, which even the oldest veterans experience, "when the blast of war once more blows in their ears;" both vessels steered direct for each other, and it was apparent that our antagonist was a frigate of the heaviest description: our long sought for opportunity seemed within our grasp, the guns were primed, the locks were cocked, not the slightest whisper was audible among the crew, whose steady and determined looks augured well for the object in view. "Stand by, my lads," echoed along the deck in the well-known deep-toned voice of the first lieutenant, while the practised eye of the captain eagerly sought a confirmation of his wishes, as he glanced through a telescope at the hull and rigging of the stranger. It was a period of the deepest interest; a few moments and the battle's din might succeed to this picture of repose. As if by magic, the American ensigns at the peak of each vessel vanished, and the proud colours of Britain waved in their place. Our yard-arms nearly touched; both captains hailed in breathless expectation, "What ship is that?" mutual recognition and a friendly salutation followed. By what a frail thread is our destiny in this strange world suspended! the slightest error or mistake, and the blood of a hundred gallant hearts would instantly have flowed. The guns were secured, and the stately fabric in the

* The late Commander Robert Pearce, who died in the arms of Capt. Clapperton, whom he accompanied to Africa, where he fell a victim to the insidious climate, whilst endeavouring to penetrate the interior and reach the far-famed city of Timbuctoo. In every branch of his profession he was a most scientific, zealous, and accomplished officer, and truly an ornament to the service.

space of five minutes was lying in as quiet and deep repose, with her maintop-sail to the mast, as if the preceding scene had been an illusion of the senses; our gallant tars consoled themselves under their disappointment, that at least they should be enabled to have a good "blow-out" of water. Our captain proceeded on board the stranger, H. M. S. *Severn*, of fifty guns, and returned with the gratifying intelligence that she would supply us with eight tons. It is impossible to paint the lively and extravagant joy demonstrated by every individual in the ship; they all literally danced and capered at the welcome news, and during this afternoon many a parched and burning throat was plentifully moistened; hunger may be borne for days without exciting a murmur, but thirst is excruciating, especially when heightened by the stimulating auxiliaries of salt junk and pork.

In the afternoon we parted company with the gallant vessel that came so opportunely to our relief, and in the course of a few days hoarded a Swedish schooner, which had an English newspaper on board stating that peace had been signed at Ghent on the 24th of December. It was now approaching to the close of February, and we dispatched our third lieutenant in the vessel to apprise Rear-Admiral Cockburn of the fact. On his return we received orders to proceed to Bermuda and refit, prior to sailing for England; our prisoners were naturally rejoiced at the news, and in our berth, where a dozen of the most respectable took up their quarters, their return to the land of their nativity, was the constant and unremitting theme. Poor fellows! during the whole cruise, we endeavoured, to the utmost, to render their lot as comfortable as circumstances would permit: they seemed fully to appreciate our kindness, especially when they observed the luxury they enjoyed in comparison with their less favoured brethren, who at night were constantly confined in the fore-hold; it was an act of necessity, but their fate really excited the deepest commiseration, not being used to the hardships and vicissitudes consequent on a maritime life. They repeatedly declared, that every soul in America had long been tired of the war and most ardently prayed for the blessings of peace. On our passage we recaptured a prize brig called the *Hope*; we boarded her under American colours, and it was with considerable difficulty the prize master could be made to comprehend that the whole affair was not a joke, as he strenuously insisted that our frigate was the Macedonian. When he came up the side, he advanced with an air of the most consummate gravity towards the captain, saying, "I guess, captain, if the *Warrior* privateer had been here, we should have shown you a little play for it; I calculate as how we should have knocked away a few of your fine spars and flying kites; but, however, captain, I surrender my sword;" at the same time suiting the action to the word with a most ridiculous mock-heroic bow. The captain coolly ordered the quarter-master to take possession of it, and the discomfited prize-master retreated over to the lee-side of the quarter-deck amidst the general titter of the assembled Mids, whilst the crest-fallen Yankee conceived himself treated with the grossest indignity and contempt.

In the beginning of March, we arrived at Bermuda, which is one of the loveliest spots in the creation to behold from the sea, but the moment you step on terra-firma the illusion vanishes—barrenness predo-

minates amidst picturesque scenery, and the grossest imposition of every description supersedes the benevolent hospitality one is led to expect in a British colony, which has attained a high degree of celebrity from the supposition of its being the spot where Shakspeare has laid the scene of his immortal *Tempest*; and although Prospero no longer waived his magic wand, yet at this period the island was enlivened by the presence of the *President*, American frigate, which had been captured by the *Endymion*, in company with a squadron of frigates under the command of Capt. Hayes. Only having once previously visited an American frigate, (the *Chesapeak* in Halifax harbour,) of course I very soon took an opportunity of gratifying my curiosity by inspecting the *President*. She was certainly a noble ship, having beams and scantling fully equal to those of a 74; her store-rooms were magnificent, and her lower yards and masts were on equally as grand a scale; she had been dreadfully cut up in her hull, while her antagonist chiefly suffered in the rigging. Of course the American pride was deeply hurt at the result of this action, but they strenuously denied being defeated by the *Endymion* singly, and said they had not struck until the *Pomone* had fired two broadsides into them; however, this point might be disputed. I happened to be on board the *Endymion* all night on duty, and in the gun-room heard the whole account of the action related to our surgeon, whose brother, Mr. Boyter, was serving on board as a master's-mate, by which it clearly appeared that if she had not already struck the *Endymion*, the superior fire and discipline of the British frigate over the American was fully apparent, as well by instituting a comparison of the loss each ship incurred, as from the circumstance of the *Endymion* bending a new suit of sails in little more than half an hour, and this too, accomplished in the darkness of night, immediately after a severe action: however, every officer on board the British frigate fully concurred in opinion, that the American had already struck, prior to the arrival of the *Pomone*. Among the *President's* crew were several Englishmen, who made no mystery of having even served on board our men-of-war, for when lying alongside the *Guard-ship*, I heard frequent conversations carried on between our boat's crew and the prisoners at the grated ports.

We were now gladdened by the arrival of our gallant fellows who had been captured by the gun-boats; they had been conveyed to Charleston, and had been exceedingly well treated, the master's-mate and assistant-surgeon being allowed their parole, and were invited to the houses of many of the principal inhabitants, where they had balls and evening parties. The Americans were excessively proud of the capture they had made, and christened our launch the *H—— junior*; every expedient was resorted to, every temptation held out to our men to induce them to enter, but it is gratifying to record, that every soul was loyal to his country. They were frequently visited in their confinement by an old Irish lady, who constantly exhorted them to be true to their King and the land of their birth. She frequently furnished them with various necessaries and comforts, of which they stood much in need.

I cannot refrain from mentioning one act of grateful recollection that does honour to the human heart. After the battle and bombard-

ment of the city of Baltimore, among several other prisoners who were confined on board our frigate, was a gentleman named Wills; he was a respectable stationer, and had been captured while serving in the National Militia; he messed in our berth, and partook with several others of such homely fare as the mids of a cruising frigate were accustomed to provide. After being conveyed to Bermuda, he had been sent home in a cartel to Baltimore. The moment the newspapers informed him of the capture of our officers and men, he addressed a letter to Mr. James Creagh, regretting that the fortune of war had made him a prisoner, and requesting him to draw upon him for any sums of money that he might require, and stating that he should never forget the kindness he had experienced on board our ship, and as a feeble return he might depend upon being furnished with every necessary his situation demanded. However the peace might have neutralized this worthy man's intentions, these are valuable traits, and tend to soften the asperities of war. Being ready for sea, the body of the late Capt. Sir Peter Parker, Bart.* was disinterred from a vault in St. George's town, and once more transferred to the custody of our gallant captain, (who had been his friend and messmate in early youth,) that the mortal remains of this lamented officer might slumber in his native land, honoured by his friends, his country, and the profession to which he was so bright an ornament. As a tribute of respect to the manes of this young hero, our ship was put into mourning by painting her sides a deep grey, and all her masts black.

Elate at the idea of once more revisiting the white cliffs of Britain, our anchors were weighed, the fluttering canvas swelled proudly to the breeze, whilst the gallant vessel ploughed the bosom of the main, until the Mudian shore sank beneath the glittering horizon. Joy was in every eye—for our destined haven was Old England.

R. J. B.

* Capt. Sir P. Parker, Bart. commanded the Menelaus frigate in August 1814, when he was ordered up the Patapsco River, near Baltimore. He landed at the head of a division of seamen and marines in the night, to attack a portion of the enemy that had assembled a few miles from the beach. Whilst traversing a wood to gain their position, the enemy, in treble the force he had been led to expect, suddenly opened a tremendous fire; the gallant and heroic Parker received a buck-shot in the thigh which pierced the femoral artery, but still continued to cheer on his men; in five minutes he fell faint and exhausted in the arms of Lieut. Robert Pearce, and in the space of few minutes more the vital spark had fled. He had bled to death. His gallant seamen and marines fought like tigers: they succeeded in carrying off all their killed and wounded. The body of Sir Peter was embalmed, and when he was removed on board our ship, the rugged countenances of his gallant crew betrayed manly grief for their heroic Captain, who fell at the early age of 29. We conveyed him to Bermuda preserved in spirits, where he was interred with all the honours due to his rank, and on being conveyed to England a party of seamen and marines, attended by the officers of our ship, followed his second funeral to St. Margaret's, Westminster.

ON THE DEFENCE OF JERSEY.

IN the event of a War with France, which sooner or later must be deemed unavoidable, an attack upon the Norman Isles is highly probable. That the defence of these islands has been thought of before can be no matter of doubt, when the importance of their possession to Great Britain and their vicinity to France are considered; and that characters of high military talent and reputation have also presided at those councils which devised the means resorted to for their protection, can no less be questioned when reference is made to the list of the Lieut.-Governors of those Isles, as well as to the names of the officers who have been successively attached to their Staffs, or again occasionally sent over by the Government for the immediate purpose of securing those islands from foreign aggression.

But let not the soldier be hereby deterred from investigation, or from delivering his sentiments on an object at once so important to the country, and of so general an interest to the Military Art, since, while he is attempting to trace a proper mode of defence for Jersey, his endeavours will serve equally to illustrate the defence of small islands in general; besides the means suggested, if differing from those already recommended may lead to disquisition, and this disquisition tend either to modify or confirm the measures previously determined on.

Without farther remarks, we shall, therefore, at once proceed to our design, by establishing, that the defence of Jersey, like that of all small islands, consists—on the principle of the defence of great rivers—first in preventing the enemy from landing; and secondly, should he succeed in landing, in preventing the troops, as they successively arrive on shore, from forming.

It is to the batteries erected along the shore we have principally to look for the attainment of the first object. They are to be so situated, after a careful survey of the coast and sounding along the same, that by their cross fire they may baffle approach to any place accessible to an enemy, as well as injure the enemy's shipping. The erecting of these batteries, and the selection of the spots where their effects will be most destructive, becomes a province of the artillery officer and engineer, assisted by the Naval department, which latter is to point out the several landing-places, together with the courses necessarily to be pursued for disembarkation. The assistance which would be derived here from the Light Brigade of Artillery will clearly appear; while the reflection, how desirable the presence of a British fleet would be at the time, will naturally suggest the advantage that would result from a harbour capable of containing a naval force (and which that of Boulay at a moderate expense would afford,) particularly when the extensive works erected at Cherbourg—calculated to shelter, I believe, the entire French fleet—are taken into consideration, as well as the numberless works in progress at the various harbours lying along the Bay of Cancale.

The second object, that of preventing the enemy from forming while landing, by driving the men back into the sea as they successively reach the shore, must depend on the united efforts of the Light Brigade of Artillery, a rapid fire of musketry, and brisk charges of a body of Cavalry or Infantry.

It becomes, therefore, obvious that the instruction of the Militia of the Normau Isles should be directed to the few evolutions which, in conformity with the above premises, it may be called upon to perform. The existing system of warfare scarcely leaves a doubt, that a hostile enterprise against Jersey by the French will never be ventured on, except by a considerable and overwhelming force, which if landed and formed would preclude resistance, unless in the instance of Fort Regent, to which the defending troops must, in that case, immediately withdraw. The small extent of the island and its high state of cultivation combine to negative any attempt at warlike operations. It is true that the bold scenery of some of the small Bays might, at first sight, favour the martial sentiment of a protracted warfare, but the idea is soon abandoned when it is observed that this favourable state of locality is of no extent, and that, seldom continuing for the space of a mile, it sinks, after two or three hillocks have been passed, into a rich and cultivated country, the general aspect of Jersey.

Assuming this mode of defence to be adopted, the expediency of the Light Brigade of Artillery, as formed by Major General Sir Colin Halkett, will be clearly seen. It consists at present of 24 Six-pionnders; were it increased in number, and the pieces, at least partly, of a heavier metal, still greater benefit would most likely result from this salutary measure.

The next object for consideration is the body of Cavalry, which the raising of a corps of Yeomanry, from three to four hundred strong, will effectually supply. The necessity on the part of each man for keeping a horse would naturally render the composition of this corps respectable, and of that valuable class of men, who cannot well be provided with commissions in the Militia, yet who, from their state of independence, hold a certain rank in their parishes.

The expected duty of this body of Cavalry would be, by repeated charges, to prevent the enemy from forming as they successively reach the shore, and to drive them back into their boats or the sea; it might likewise, as well as the Light Brigade of Artillery, be of great advantage in covering the retreat by checking the enemy's advance as much as possible. These corps, the Light Artillery and Cavalry, should be severally divided into three bodies, which, in the event of alarm, should repair, each to its appropriate station, namely, the three principal landing-places, St. Ouen, Granville, and St. Aubin Bays: and here, the advantage of dispatch which would immediately result from the suggestion of Sir Colin Halkett to erect the sheds or stores for the use of the Artillery, and to keep the pieces, at these three principal points at which attack may be apprehended, is manifest. Were, in war time, a few large waggons also, kept in readiness within these stores or sheds, capable of conveying bodies of Infantry from one Bay to another, as circumstances may render urgent, additional benefit would accrue, while the appropriate situation of these warlike stores at the three chief points of assault, would become still more conspicuous.

It will be evident that the proximity of the inhabitants to St. Ouen, Granville, or St. Aubin's Bay, and the local situations of their abodes, must chiefly influence their appointments to the particular division of the corps of Light Artillery and Horse to which they belong; and

that the same principle should be acted on in directing the individuals to their respective batteries.

The Brigade of Light Artillery, and corps of Yeomanry Cavalry being filled up, and the persons to be attached to the several batteries along the coast appointed—these principal-objects of defence provided for—the remaining part of the inhabitants may be distributed into four regiments of infantry, of which one would likewise, in case of alarm, assemble at St. Ouen, one at Granville Bay, and one at St. Aubin's Bay and the town. The fourth, destined to the defence of the smaller accessible harbours,—Greve de Lecq, Bonuit, Boulay Bay, Roselle, and St. Catharine, and to re-inforce the detachments of regulars stationed at those posts, might, by companies, repair to the churches of St. Mary, St. John, Trinity, and St. Martin, to proceed from thence to their respective destination, or wherever their services may be required.

The same precautions should be taken to provide for the defence of St. Brelade's Bay, and the eastern coast of St. Clement, by directing thither detachments of the Granville, and St. Aubin regiments, or appointing those posts as *rendezvous* for one or two companies of those regiments.

That such an arrangement, though deemed fundamental, should undergo occasional alteration, and, that in the case of invasion, the several corps once assembled, should be liable to leave their stations to repair to the points attacked, need scarcely be observed; but this becomes the province of the General commanding, who, prepared against surprise, and knowing where his forces lie, will direct them where threatened, so as to act in mass against the assailant.

The distribution of the inhabitants into the foot regiments again, should be chiefly determined by their proximity to the assembling posts, without any attention being paid to the boundaries of the parishes, or in fact, any other consideration whatever, but that which promotes the defence of the island, the great, and indeed, the sole object, to which every other must give way.

It may not be altogether inappropriate here to say a few words respecting the movements to which the Militia of the Norman Isles might be trained, according to the view we have taken of the defence of the island; namely, to prevent the hostile troops, while landing, from forming, and to repel them from the shore. These movements we shall readily find to be the charge in line, and the charge of a line of central double columns, as practised by the Russians; the instruction of the Militia should accordingly be principally confined to the advance and charge in line, to the formation of the close column in rear of the right division, and that in front of the left company; and, while in mass, to marching to the front, to the rear, to either flank, and wheeling in all directions; and they should particularly be rendered familiar with the centre double column, which, formed by the companies of the right wing moving rapidly behind the right centre company, and companies of the left wing behind the left centre company, is immediately to be advanced to the charge, which is here effected on the front of a grand division. The instant preceding collision, a discharge of the two front ranks may be directed; and while rushing forward to the shock, the two companies in rear may file out, to act as

tirailleurs, or form in line on each flank. The latter are to pursue the flying enemy, while the double column, after its successful charge, halts, rapidly deploys into line, to fire by half battalions, or to give a volley as soon as extended.

The firings in which the militia-men are to be practised, might be reduced to the volley, the firing by half battalions, and that by alternate companies, in which two companies acting independently and together, the one fires as soon as the other is loaded.

In conclusion, we shall venture a few remarks respecting the roads, which, as they were established by General Don, as a means of defence, (by facilitating the rapid march of the troops, and conveying the artillery to the points of attack,) cannot well be left unnoticed. Without entering into tactical discussions respecting their military advantages, or balancing the benefits they procure by promoting the conveyance of troops to the threatened points, against the disadvantages they present, by favouring the advance of an enemy, after he has effected a landing; and admitting such roads to be of general utility to the island, it is impossible to forbear remarking how much the object of facilitating the progress of troops might have been promoted, had a more regular system been pursued in the cutting of the roads. For instance, had a main road been constructed in as straight a line as circumstances would permit, from St. Ouen's Bay to Granville Bay, it would have accelerated the removal of troops from one of the principal points of attack to the other; and this road, by dividing the island, would have admitted of several cross roads to the churches of St. Mary, St. John, Trinity, and St. Martin, and from thence continuing to the harbours of Greve de Lecq, Bonuit, Boulay, Roselle, and St. Catharine; as well as allowed on the southern side a cross road to St. Brelade, and two broader ones, the one to St. Aubin's Bay, the other to St. Helier: the latter would have joined the main road, about half a mile or a mile beyond St. Saviour's church. The road from St. Ouen's, round the island, and passing through St. Mary, St. John, Trinity, St. Martin, Granville, St. Clement, to town, might have been preserved, as well as the road along the shore from St. Helier's to St. Brelade.

On the roads leading to St. Helier's, from the main road, at about a mile or a mile and a half from town, slight works, capable of arresting the enemy for a while, might have been erected, and this might have been likewise repeated on the St. Brelade road leading to town. The advantages which would accrue from thus delaying the enemy, were it even but for half an hour, would be exceedingly great; as whatever might be the precautionary measures taken to put Fort Regent into a state of defence, the influx of troops and inhabitants pouring toward the town, must lead to some disorder, which the temporary retardment the assailant experiences in his progress, by the necessity of carrying these works, might afford time to repair.

LUPUS.

REMINISCENCES OF A SUBALTERN.

NO V.

WE occupied our old quarters at Nave-d'Aver, and were well received by the inhabitants, who preferred taking a quiet view of the combats of the 3rd and 5th to taking a part in both or either; their plan of operations was of a far different sort, and, although unattended with any danger to themselves, was fraught with the most disastrous consequences to their foes, which is, no matter what may be urged against it, the very essence of the art of war.

It may perhaps be asked what their method was? or why I, a mere subaltern, should take upon myself the censorship of the art of war? My answer to the former shall be plain and I hope conclusive. To the latter, that having served during part of the year 1809, the entire of 1810, 11, 12, and part of 13, in the third division (commonly designated the *fighting division*) of the Peninsular army—and the division never having, during the period alluded to, squibbed off as much as one cartridge without my being in my place—I had opportunities of gaining, and I think I did gain, a little insight into military tactics. If, however, the view I have taken of the subject upon which I am speaking, be an erroneous one, I fear my readers will come to the conclusion that I have lost some time which might have been better employed, or to speak more plainly, that I have mistaken my profession. Marshal Saxe used to say, that a mule which had made twenty campaigns under Cæsar would still be but a mule.

I have digressed thus far before touching on a subject that no doubt (although I have not seen any work of the kind) has been written upon, and upon which much diversity of opinion did exist at one time in England; whether it still exists or no I shall not pretend to say, not having been in the United Kingdom for some years; but certain it is that a very general opinion was prevalent that the war in the Peninsula was carried on, on the part of the peasantry, in a spirit bordering more on a crusade, than the ordinary exertions of a brave people struggling for liberty; and that those heroes fought more like a parcel of devils incarnate than mortal men. Indeed the engravings struck off at Lisbon in commemoration of those days, certainly represented them as a gigantic, ferocious people, while the few British, that were thrown into the back-ground, looked like so many dwarfs, who were afraid to come to close quarters with the French. I have ever combated this mistaken opinion, nor does the recollection of the hundreds of those heroes that I have seen marched to the different depôts, handcuffed like a parcel of criminals, weaken the view I have taken of the *voluntary* part the Peninsular People took in the contest. In a word, their plan was this.

The moment our troops had completely routed a parcel of the enemy's infantry, strewing the ground with dead and wounded, disorganized a park of artillery, or unhorsed some squadrons of dragoons, then, and then only would these *gallant fellows* sally forth from their lurking-places, and, first taking the precaution to put a stop to any sort of parley from their unfortunate victims by knocking them on the head, completely rife them of every thing they possessed. On the contrary,

if our troops met with any reverse, as in the case of Don Julian Sanchez and his ragged band, our allies would take advantage of every accident of ground, and make one of those rapid retrograde movements, sufficient to baffle the evolutions of the most redoubtable *legère* regiment in the French army. This, I say, is the true harassing system, and the one suited to the genius of the Peninsular nations. It weakens your enemy, and is attended with no risk to yourselves or your friends, which is the same thing; for in England many think that the Portuguese and Spaniards did as much, if not more, during the Peninsular contest, than the British army.

I remember once, upon my return home in the year 1813, getting myself closely cross-examined by an old lawyer, because I said I thought the Portuguese troops inferior to the French, still more to the British. "Inferior to the British, Sir! I have read Lord Wellington's last dispatch, and *he* says the Portuguese fought as well as the British, and I suppose you won't contradict *him*!" I saw it was vain to convince this pugnacious old man of the *necessity* for saying those complimentary things, and we parted mutually dissatisfied with each other; he taking me, no doubt, for a forward young ignorant puppy, and I looking upon him as a monstrous old bore.

After the affair of Pombal, Gen. Beresford was detached with the second division to the province of Alentejo. He passed the Tagus at Villa Velha, and reached Portalegre on the 20th of March. On the 24th he advanced to Campo-Mayor; this town was occupied by three thousand French troops, under the command of Gen. Latour Maubourg. On perceiving the advanced guard of Gen. Beresford's army, he quitted the town, and established his troops on the heights in its rear. The 13th regiment of light dragoons gallantly charged the cavalry of Latour Maubourg and overthrew them at the first onset, but the French infantry, which were posted behind their cavalry, formed into square, and not only protected their own horse, but drove back ours with considerable loss. The bravery of the infantry saved their cavalry from total defeat and disgrace, and gave them time to reform and advance again to the combat. The infantry, with that promptitude which characterizes French troops, took advantage of this change in their favour, and continued their march upon Badajoz, repeatedly performing this fine manœuvre, and at last succeeded in reaching the Guadiana unbroken, and unquestionably with the honours of the day on their side. They neither lost baggage or cannon, and not more than twenty prisoners fell into our hands. The conduct of the 13th Light Dragoons in this affair was particularly dashing.

Gen. Beresford quartered his army in the neighbourhood of Elvas, and made preparations to act on the left bank of the Guadiana. On the 4th of April he passed that river with little opposition. He reconnoitred Olivenza, and was informed by his spies that the garrison consisted of only five hundred infantry. This was doubtless an oversight on the part of the Duke of Dalmatia, because a town of such extent required a force of at least three thousand men. No time was lost in investing it; the first parallel was completed on the 12th of April; on the 15th the batteries opened, and on the same day Olivenza surrendered; but the power of the enemy was still unshaken; the surprise of a single garrison, though a distinguished evidence of what

might be done by our troops, was trivial in the scale of a war to be conducted against the whole power of France.

Matters remained thus in this quarter, and Lord Wellington, after the battle of Fuentes-de-Onore, and the retreat of the army of Portugal across the Agueda, employed himself in giving directions for the repairs of the injury inflicted by Brennier upon Almeida previous to his evacuation of that fortress.

The troops had recovered from their fatigues and were fresh again, and ready for any thing, when accounts reached us from the Alentejo that Gen. Beresford was carrying on the siege of Badajoz, in which operation he was likely to be disturbed by Marshal Soult, who was on his march from Seville. Our division broke up from its cantonments on the 16th of May, and Lord Wellington, who rode at a rapid pace, reached Elvas in three days. There he received the report of the battle of Albuera.

The weather was fine and we continued our route without any forced marches, taking the old beaten track through Castello Branco, Niza, and Portalegre. Our march was uninterrupted by any particular incident; we had no enemy near us, and were therefore left to ourselves. The soldiers were gay as was usual, full of that humour and anecdote which none but those who have served with an Irish regiment can estimate; and the dead Frenchman on the banks of the Duos Casas still afforded amusement to the women. "Well, yees may all be talking," said Mrs. Murphy of the grenadier company; "Yees may all say what yees like, but he was the boy after all; Och! 'twas he, when he was alive, (the Lord be merciful to his soul!) it was he that wouldn't be long coaxing a girl out of her sarvice." "Well, a'tanny rate, Mrs. Murphy," said Tim Muldoon, the tailor of the company, "he had a mighty ugly big head." "A big head! faith and every thing about him was big," rejoined she; "but what the devil are you but a *tailor*, and that's the ninth part of a man." A shout followed this *hit* of Mrs. Murphy's, and poor Muldoon was mum for the remainder of the day.

I pressed Bell, our staff-surgeon, to preserve the skeleton of this herculean figure, but he said it was too cumbrous, and that besides he had enough of *living* subjects to occupy him, without attending to *dead* ones. The Turk that assassinated Kleber at Cairo, and whose skeleton they show in the Museum at the Garden of Plants in Paris, was a large man, but he was a mere pigmy as compared with this fellow.

The French army have the character of being the best marchers in Europe, and I know from experience that no men, to use a phrase of the "Fancy," understand better than they do, how to "hit and get away;" nevertheless, I would say, that an army composed exclusively of Irishmen would outmarch any French army, as much as I know they would outfight them. The quality which carries a Frenchman through, and enables him to overcome obstacles truly formidable in themselves, is his gaiety, and his facility of accommodating not only his demeanour but his *stomach* also, to circumstances as they require it. An Irishman is to the full as gay as a Frenchman; if he does not possess his *piquant* wit,—and I don't say that he does not,—he has in a paramount degree the rich humour of his own country, which is no where else to be found. He can live on as little

nourishment as a Frenchman; give him his pipe of tobacco, and he will march for two days without food and without *grumbling*—give him, in addition, a little spirits and a biscuit, and he will work for a week. This will not be a task so easy of accomplishment to the English soldier; early habits have given him a relish for good eating, and plenty of it too: if he has not a regular allowance of solid food, it is certain he will not do his work well for any great length of time. But an Irish fellow has been accustomed all his life to be what an Englishman would consider half-starved; therefore quantity or quality is no great consideration with him; his stomach is like a corner cupboard—*you might throw any thing into it!* Neither do you find elsewhere the lively thought, the cheerful song, or pleasant story to be met *only* in an Irish regiment. We had a few Englishmen in my corps, and I do not remember ever to have heard one of them attempt a joke. But there are those who think an Irish regiment more difficult to manage than that of any other nation. Never was there a more erroneous idea. The English soldier is to the full as drunken as the Irish, and not half so pleasant in his liquor.

These opinions are, however, mere matter of fancy. Some of our best regiments were English, and one, to please me, decidedly the finest in the Peninsular army, the 43rd, was principally composed of Englishmen. Then there was that first-rate battle regiment, the 45th, a parcel of Nottingham weavers, whose sedentary habits would lead you to suppose they could not be prime marchers, but the contrary was the fact, and they marched to the full as well as my own corps, which were all Irish save three or four. But if it come to a hard tug, and that we had neither rations or shoes, then, indeed, the Connaught Rangers would be in their element, and outmarch almost any battalion in the service; and for this plain reason, that scarcely one of them wore many pair of shoes prior to the date of his enlistment, and as to the rations, (the most part of them at all events) a dozen times had been in all probability the *outside* of their acquaintance with such a delicacy.

But the grand secret, in a good marching, good fighting, or loyal regiment, one not given to a habit of deserting, is being *well commanded*; because the finest body of men may be ruined, the efforts of the bravest regiment paralyzed, and the best disposed corps become marauders and deserters, from having an inefficient man at their head.

At a period later than the one I am touching upon, my regiment was placed in a situation where the greatest facilities were afforded, and the strongest temptation made use of, to induce the men to desert. Several regiments lost from one to three hundred men each! but notwithstanding that we were stationed on the bank of a river, within a few hours' sail of the American territory—notwithstanding that the river was crowded with their trading vessels, and that more than one third of the battalion were allowed daily to work on board those ships, which were hourly arriving and departing,—and notwithstanding that we had no possible means of preventing the desertion of the entire regiment in a night if they chose it—*we never lost one man!*

This is a fact that I take the greatest pride in recording of my old comrades, and a point that in my opinion is worthy the attention of officers at the head of regiments. It may not be amiss to add that the

men, generally speaking, were in debt in consequence of the arrival of a detachment from Ireland; the company I paid owed about fifty pounds, and the other companies averaged the same amount. But by a good commanding officer, I do not mean one too fond of *quackery*—quite the contrary. Too much training is as bad as too little; we had no fuss with our men—no chocolate breakfast, and we had but few, as compared with others, on the sick list. We generally turned out half as strong again as other regiments; but ours was no rule to go by, because the soldiers were too hardy to be overcome by any ordinary fatigue, and too good-humoured, if they were, to let their officers know it. Poor Joe Kelly used to call us *the united Irishmen*.

Colonel Alexander Wallace, who commanded us for so many years, and under whom the regiment repeatedly covered itself with glory, was the very kind of man we wanted. Although a Scotsman himself, he was intimately acquainted with the sort of men he had under him, and he dealt with them, and addressed their feelings, in a way that was peculiar to himself, and suited to them. In action he was the same as on parade, and in either case he was as he should be. If we were placed (as we often were) in any critical situation, he would explain to the soldiers what he expected them to do; if in danger of being charged by cavalry, he would say, "Mind the square; you know I often told you that if ever you had to form it from line, in face of an enemy, you'd be in a d—d ugly way, and have plenty of noise about you; mind the tellings off, and don't give the *false touch* to your right or left hand man; for by G—d, if you are once broken, you'll be running here and there like a parcel of *frightened pullets!*" But Colonel Wallace was out of his place as a mere commander of a regiment; he was eminently calculated to head a division, because he not only possessed that intrepidity of mind which would brave any danger, but genius to discover the means of overcoming it. It was by his foresight that our brave companions, the 45th, were sustained in their unequal contest with Reigner's division at Busacco; and Lord Wellington who saw, and fully appreciated the manœuvre, rode up to the 88th Regiment, and seizing Colonel Wallace by the hand said—"Upon my honour, Wallace, I never witnessed a more gallant charge than that just now made by your battalions." The dead and wounded of the 2nd, 4th, 36th, and Irish brigade, (four French regiments which were opposed to the 88th singly,) lay thick on the face of the hill, and their numbers gave ample testimony that we deserved the praises bestowed upon us by our General. The 45th also came in for their share of praise, and no battalion ever merited it better than they did,—at one time they were engaged with nearly ten times their own numbers.

It was the fashion with some to think that the 88th were a parcel of wild, rattling rascals, ready for a row—but loosely officered. The direct contrary was the fact. Perhaps in the whole British army there was not one regiment so severely drilled. If a man coughed in the ranks, he was punished; if the sling of the firelock, for an instant, left the hollow of the shoulder when it should not, he was punished; and if he moved his knapsack when standing at *ease*, he was punished, more or less, of course, according to the offence. The consequence of this system, exclusively Colonel Wallace's, was that the men never had the

appearance of being fatigued upon a march, and when they halted, you did not see them thrusting their firelocks against their packs to support them. Poor Bob Hardiman of the 45th said, the reason the Connaught Rangers carried their packs better than any other regiment was, *that they never had any thing in them!* and, to speak candidly, we never had more than was necessary, and in truth it was very little that satisfied our fellows. A writer of celebrity so strongly bears me out in what I have been saying, that I shall take leave to quote a few lines of *his* opinion of my old corps.

“ Our division continued to march in pursuit of the enemy till near dark, when we took up our quarters in some villages and farm-houses. In one of these latter, where I was proceeding to quarter some of my company, I found a party of the light company of the 88th or Connaught Rangers, who after the pursuit of the enemy had brought up there for the night. They were all tolerably fresh, as may be supposed, and were seated round the fire cutting their jokes, as they contemplated with greedy looks the culinary process which was taking place in a large cauldron depending from the roof of a kitchen chimney. The first salutation I received on entering was, ‘ Plase your honour, you will be after taking some of our supper; we have got a couple of geese boiled in wine!’ This invitation, however my curiosity might have disposed me to taste of so novel a dish, I could not accept; but I left a party of my soldiers to assist them in discussing the banquet, which I have no doubt was highly palatable. This 88th, although from their name one would suppose them to be a rollicking set, was a very good regiment and in excellent order. They had always a soldier-like look, and they carried their packs well, which, trifling as the circumstance may appear, is a sure sign of a good service regiment.”*

At drill our manœuvres were chiefly confined to line marching, echelon movements and formation of the square in every possible way; and in all those we excelled. Colonel Wallace was very unlike an old Major, who having once got his battalion *into* square, totally forgot how to get it *out of it*. Having tried several ways, each time more effectually clubbing the sections, he thus addressed his officers and soldiers. “ Gentlemen! I can clearly discern that there is a *something wanting*, and I strongly recommend you, when you reach your barracks, to *peruse Dundas!*—Men, you may go home”—and he thus dismissed them.

I never remember our having as much as one adjutant’s drill; all was done by the commanding officer himself. Our adjutant was left ill at Lisbon, and he that acted, was more of a good pen-man (an essential point) than a drill. I forget now how the circumstance of our having been sent an adjutant from the Guards occurred; but one of their sergeant-majors did reach us in the capacity of adjutant: on his arrival at head-quarters he dined with the Colonel, who invited him to attend parade the next morning. We were under arms at ten, and never once ordered arms until two! not a man fell out of the ranks, not a man coughed, and not a man moved his pack. When the drill was over, “ Well,” said Colonel Wallace, “ what do you think of the state of the battalion?” “ Very steady indeed, Sir,” replied the guardsman. He left us that night, *and we never saw him afterwards!* no one knew where he went, but it was conjectured that he was unused to the mode of discipline he had just witnessed, and that he was un-

* Twelve Years’ Military Adventure, Vol. II. p. 330.

willing to embark in an undertaking that most unquestionably would be no sinecure. I was not sorry for this, because I always had, and have, an aversion to adjutants raised from the ranks. An adjutant is, properly speaking, the mouth-piece of his commanding officer, and should be a gentleman capable of writing a good official letter; and surely this cannot be expected or looked for in a man raised from the station of a private soldier.

I knew two persons of this description: one commenced an official letter, and concluded with stating that his wife and children were *quite hearty*. The other, one evening in a large company, hearing an argument carried on as to the different merits of Virgil and Homer, said, "They might be fine fellows for aught he either knew or cared, but that he would lay a bet neither of them ever *smelt powder*," and he would, without doubt, have won his wager.

On the 22nd of May, our division reached Niza. Any person who has ever had the misfortune to remain an hour in that filthy place, must, no doubt, remember the squalid appearance of its inhabitants; perhaps the world does not contain a more wretched race than those beings. The Portuguese nation are at best rather a dirty race, but Niza as compared with other towns, is like a filthy puddle, in comparison to a clear stream. It is one of those antiquated, fortified, and neglected towns, which, like Aronches, Portalegre, and Campo-Mayor, was once of some importance. At present, it is remarkable but for two things—the dirt of its inhabitants, and the number of storks that inhabit an old Moorish castle which stands in the centre of the town. Notwithstanding the countless number of those birds, and the voracious attacks which they make upon frogs, toads, serpents, and other reptiles, (I wish they would attack the people!) the ditches were filled with the latter. Several of the soldiers were stung by vipers and centipedes, and although I escaped both, I was frightfully bitten by fleas.

On marching out the following morning, we had not proceeded more than a league on the Portalegre road, when Mrs. Howley, the black cymbal-man's wife, ran up to our Assistant-Surgeon, who was walking with me, and accosted him thus: "Och! Doctor Jewel, what will become of me? a *great baste of a santepetre* (the woman meant a centipede!) has bit my poor infant in the ——" The screams of young Sambo effectually drowned the last word delivered by Mrs. Howley; but it was too evident, from appearances, that the part she alluded to was high up on the back of the thigh, where a large protuberance was visible. The colour of the skin was much altered; it could scarcely be said to be for the *worse*; but black as the little creature's hide was, it was manifest that Mrs. Howley, as well as her "infant," had ample cause for complaint.

On the 24th of May, we reached Campo-Mayor, and here I became acquainted with Maurice Quill. It would be quite idle in me to attempt giving any very detailed account of a character so well known; one, who whenever he opened his mouth was sure to raise a laugh, and often before he had time to speak; and he by whom I was introduced (Dr. O'Reily) was little, if any thing, inferior to Quill in either eccentricity or humour.

The first question Quill asked O'Reily was, if we all slept soundly

the night Brennier got away from Almeida. O'Reily replied, that some of *our* army certainly slept sounder than was desirable; but that in *their* affair at Albuera, they did seem to have had their eyes perfectly open, not only during the action, but after it;—at this moment, a couple of hundred of those troops that had been broken by the Polish horse, having escaped from the enemy, passed us.

During our conversation, O'Reily, as was customary with him, became quite abstracted, and apparently absorbed in his own reflections, and upon our turning round, we discovered him in one of Mendoza's attitudes! "What are you squaring at?" demanded Maurice. "My good friend Quill," replied O'Reily, "I have long felt the difficulty of coming to a satisfactory conclusion as to the probability of *science* being eventually able to overcome savage strength. There is much, Sir, to be said on *both* sides of the question, and I have great doubts concerning the battle about to be decided."—"What battle? why sure we are not going to fight another so soon?" said Quill. "The fight to which I allude, Sir," said O'Reily, with Quixote-like gravity,—for he paused between every word—"is the one pending between Crib and the black man Molineaux; it will be a contest of *science* against brute strength"—and he threw himself into one of the finest defensive attitudes I ever saw; "there," said he, "there is the true science for you; nevertheless, it might be overcome by savage strength, and there is the rub, Sir. I have devoted much time in endeavouring to come to a satisfactory conclusion on this point, but hitherto without effect; so I must await the issue of this fearful encounter; and my dear Quill, having said so much on the subject, allow me to wish you a very good morning." It was evident, that although Quill was no *novice*, O'Reily had taken a *rise out of him*, and it afforded us matter of amusement for many a day after.

We remained in Campo-Mayor until the 27th of May, (in order to allow the stores and battering-train from Elvas to arrive,) on which day we passed the Guadiana at a ford, distant from San Christoval about three cannon-shots: we received no interruption in our passage of the river, and the operation was performed without loss. The 28th, 29th, and 30th, were taken up in marking out our camp and constructing huts; and as the weather was beautiful, and our camp abundantly supplied by the peasantry, we passed a very agreeable time of it.

The river ran within a few yards of us; its marshy banks being thickly covered with plantations of olives, afforded a delightful shade to us when we either went to fish or bathe. Its breadth at this point might be about sixty toises, and it was well stocked with fine mullet. We had several expert fishermen amongst us, and they contrived not only to supply their own tables with fish, but also to increase the comforts of their friends.

(To be continued.)

SURVEY OF THE WEST COAST OF AFRICA IN 1825-6.*

HAVING accomplished the principal object of our coming into the river Congo, which was to procure wood, water, and such fresh provisions as could be met with, on the fourth day we weighed anchor, and continued our course to the northward; but as the wind was too light to admit of our making much progress, we sent the pinnace in shore to survey. The country from the Congo to Kabinda is particularly fertile, and has a most luxuriant appearance, with, I should imagine, a large population, as we observed numerous canoes fishing. In the evening of the second day from our leaving the Congo, we anchored off Kabinda, and on the following morning got into the bay with the sea-breeze. This is a small but very good harbour for moderate-sized vessels, being one mile and a half in length, with about five fathoms water in the deepest part. Situated at the head of the bay is a large town,† where the king resides. The huts here are well-built and capacious, and we found the natives very desirous of "making trade." The surrounding country, as seen from the anchorage, appeared in a high state of cultivation; but whether the soil is indebted to the inhabitants, or Nature, we could not determine. The latter is whimsically prolific on some parts of this coast, while at others her sterile frown withers every bud of vegetation as it shoots forth. We were here told many instances of treachery practised by the tribes upon the northern shore of the Congo. They were represented as watching every opportunity to attack the Portuguese boats, when, in case of their succeeding, they use their prisoners in the most inhuman manner, torturing the unfortunate whites, and ultimately burning them; while the blacks are preserved to be sold as slaves. We found five vessels at anchor in the harbour, and as the principal traffic of the place is in slaves, we had little doubt of their intentions, in spite of their vehement assertions that ivory was the sole object of their desires. In fact, had we believed one half the vows and protestations made by the various masters of traders upon this coast, we and the poor elephants would have had enough to do; for the vilest slaver that plods his blood-stained way‡

* Continued from page 42.

† When a town is spoken of in this journal as being large, the reader must not picture to his imagination a city of streets, squares, and palaces, but a few rudely-formed huts, projected by necessity, and constructed by instinct, unassisted by art; yet in a country where the most important is not larger than a European village, such a distinction serves in some measure as a guide to their relative sizes.

‡ This must not be considered a mere figure of speech, as an extraordinary sagacity in the shark renders it a horrible reality. These destructive animals appear to know the cargo which the vessel is freighted with, and are constantly in attendance during their course, looking out with the voracity so justly attributed to them for their daily meal; nay, I have heard many who were likely to be well acquainted in such matters state, that they had not a doubt but that frequently the same sharks have followed slave-ships the whole of their voyage from Africa to the Brazils, and as seldom many hours passed without a fresh bait to entice them, this is not at all improbable. Their meal is provided by the sufferings of human nature overcoming the fortitude of despair; when the miserable victim sinks beneath the accumulated load of woe and disease, to regain his liberty by the hand of death! The body is then thrown overboard to the expecting shark, who, as he greedily carries off his prey, leaves a slight eddy, tinged with blood, to mark his course. This is the tomb of many thousand slaves!—their only requiem the rolling billow and the howling wind,—their only sepulchre the monster's jaws!

along these seas, will swear to you by all the numerous saints and sinners the Catholic calendar can boast of, that he comes for ivory; and "because it is a pleasant cruise from the Brazils," as one fellow had the impudence to tell me, without stirring a muscle of his cut-throat, Portuguese-looking countenance. I feel confident, that if but one-third of the vessels got any supply who profess being in the ivory trade, not a tooth would be left in the head of any elephant or hippopotamus upon the coast!

Several canoes came alongside with stock, which met with a ready sale at moderate prices: for an old calico shirt or pocket-handkerchief we procured a pair of large fowls, and sweet potatoes enough for a week. The natives were very desirous of procuring tobacco, but as our crew were not overstocked, we did not barter much in that article. Parrots are very numerous here, enlivening the woods with the most shrill and discordant noises. The boats having surveyed the whole of this harbour in the course of a day, we proceeded along the coast, which continued to bear the most fertile appearance, terminated by high red cliffs seen in the distance. Just before making Loango Bay, we passed several small villages, and the country became very low and woody. Observing an English schooner at anchor up the bay, we hauled in for her, and sent a boat on board, which shortly returned with the master. She proved to be a vessel from Liverpool, had been on the coast fifteen months, *really* trading for ivory, and had succeeded in procuring ten tons. This bay is about two miles and a half in depth, and affords good anchorage, but we were led to believe very thinly inhabited, as not a single canoe came off with stock. We continued our course, surveying along shore, and coming to at night, until we made Point Matoote, which forms the southern extremity of Mayumba Bay. Just off this place there is a most dangerous ridge of rocks, partly visible above water, with a channel of three fathoms and a half between it and the Point; but it is advisable to avoid it entirely, if possible, by going outside. Mayumba was formerly a place of much trade, but is now in a wretched state of poverty and dilapidation. The probable cause of this is the anchorage not being good, as a heavy swell generally sets in when the wind blows on shore, in consequence of there being no shelter, unless by lying close in upon the southern side of the bay, which for many reasons is not advisable. We now came upon a very flat swampy coast, passing the Sette, a small river with a bar at its entrance and numerous small creeks covered on each side with thick jungle, which almost gave us the fever to look at, so humid and pestiferous did they appear. We next came to off Camina, a small bight, with a town of the same name, where several canoes came alongside with stock. These were the first we met with rowing oars instead of paddles; they introduced themselves, by asking if we came to traffic in slaves, and expressed much astonishment and dissatisfaction upon being informed that such was not our object. The following morning we again weighed, and passed a very low sandy country, with numerous small creeks, apparently forming woody islands in the interior. The next place we made was Cape Lopez, which we hauled round, and then came to, it being nearly dark. At daylight the following morning, sent boats away surveying, and to cut wood; they met with many large herds of buffaloes, but very wild and shy.

The Doctor contrived, however, to shoot one, which being high in perfection, proved a great acquisition to our fresh stock. Some of the party brought on board various specimens of beautiful shells, which had been picked up on the beach; fish and turtle were also found very abundant at this part of the bay. During the night we had a storm, accompanied with the most vivid and terrific thunder and lightning. In the morning we stood across the bay; when about five miles and a half from the Cape, we met with a very dangerous shoal, extending nearly two leagues seaward from Prince's Point, some parts of which can be distinguished by a ripple: between this and the Cape the water is very deep with a muddy bottom. When we hauled round this shoal, we observed a brig at anchor, and shortly afterwards a small schooner. As we continued beating up to the head of the bay against a strong tide, all the boats were dispatched to survey. I took the pinnace and went on the eastern coast, but a heavy rain prevented my making much progress. We passed several hippopotami, considerably larger than those we had generally seen. Finding the rain continue, I made the boat snug for the night, taking every precaution to keep out the torrent which came down with soaking violence, and succeeded so far, as only to find my nightcap quite wet upon awaking in the morning, my head having, it appeared, occupied the only spot through which a drop had penetrated. Having fortified the inward man, we commenced our work, and in the course of the day were enabled, with the assistance of a fresh breeze, to complete nearly thirteen miles of coast. This side of the bay is one continued mangrove, with the exception of about three quarters of a mile, consisting of a sandy beach. These mangroves bear the most feverish-looking aspect it is possible to conceive, and are the general boundary of all rivers upon this part of the coast. Their being composed entirely of mud, prevents the possibility of any landing being effected in the neighbourhood; they are the resort of every disgusting and venomous insect and reptile—

“ With all the infections that the sun sucks up
From bogs, fens, flats, ——!”

The effluvium from these pestilential marshes, when the burning sun has been upon them for a few hours, is of the most revolting nature, being an exhalation from all the filth which has accumulated for centuries in the river, and here undergoes the gradual process of decomposition. They are the dread of Europeans, and to us, who had frequently to sleep in boats for many nights together, surrounded by them on all sides, they proved very fatal; seldom were we fortunate enough to escape from fever, or other sad memento to remind us of their deadly influence. Towards sunset, I anchored for the night off the town, which is called Feteesh Town, situated just by the before-mentioned small sandy beach; while running down for this spot, we found a brig at anchor, and were informed that she was French, trading for ivory, (*doubtless black,*) and tortoiseshell. Upon coming to off the town, we observed several people waving handkerchiefs: this being an article of civilization not yet known amongst the natives, nay, not even the receptacle from which it receives its cognomen, I concluded the proprietors must be of European extraction. How strange that such a conclusion was inevitable! Is it not also strange, that Nature, when

she made noses, omitted to make pocket-handkerchiefs? She surely must have thought we could do without them, or she would at least have made pockets. The inference was about as flattering to our enlightened nasal organs, as that of the traveller who was delighted at seeing a man upon a gibbet, because it convinced him that he was in a civilized country: so we hailed the pocket-handkerchiefs as an emblem of civilization. But the most satisfactory conclusion we can come to is, that white, or cultivated noses, require more attention than the black, unsophisticated proboscis, of rude uncultivated nature!

These cogitations induced me to hoist an ensign, upon which a canoe came off with a Frenchman in her, who stated upon coming alongside, that he belonged to the brig before mentioned; and on getting into my boat, farther informed me, that the natives had insisted upon his coming off to discover our character and intentions, as they were greatly afraid we were pirates. Seeing a large boat well manned with white faces was certainly enough to raise their suspicions, however little we might feel it as a compliment. Many things combine in this country to deprive a man of his vanity, and make him almost wish to possess the perfections so much prized in the land he is. Some of our handsome fellows, in their own conceit, including myself, were much wonder-struck at finding that Nature had not one standard of beauty for all the world. I used to consider myself an uncommon *good-looking fellow!* and when walking down Bond-street upon half-pay, counted on numerous conquests *en passant*; but when we arrived on this tasteless coast, I could produce no effect upon the Venuses of Hottentot; their black hearts, hard as the forehead of Satan, resisted the light darts of a northern Cupid; each charm here lost its power: lips formed like the urchin's bow, and red as melting cherries, were eclipsed by the letter-box pouters of the native Adonises; the nose of sculptured beauty gave place to the bisected baking-pear; while the hair of glossy brightness lost every charm when put in competition with the roasted, wool-looking stuff, on the head of their beaux. *This* was another attack upon our vanity, because our faces were white, these discerning natives thought we *must* be thieves! To continue.

The Frenchman, having convinced himself of our honesty and peaceful intentions, went on shore and reported to that effect; this I afterwards learnt gave great satisfaction to the hearers. Having received an invitation from my visitor to come and see him, I went on shore in the evening, previously taking every precaution to guard against any attack, which the treacherous character of the natives upon this coast always rendered probable; for, with every appearance of friendship and good-will, they are sometimes watching a favourable opportunity to knock you on the head for the sake of your buttocks and scalp. Upon landing, and having sent the boat from the beach, several people came from the bush, who, I have no doubt, were stationed there in order to make observations upon our conduct. These fellows seeing only one man leave the boat besides myself, concluded we had not any hostile intentions, so came forward and joined us, shaking hands in the most cordial manner; they then led me to the house of my friend the Frenchman, which was a native hut provided for him by the king; and as most of these habitations were very well built, and

spacious, he was pretty comfortably lodged. Upon entering, I found four other Frenchmen belonging to the brig with my introducer, all of whom said they considered themselves as perfectly safe on shore, the natives being extremely docile and friendly. But I was led to imagine this civility only lasted so long as they could get any thing by their visitors; and I was farther convinced of this by the very familiar manner in which they helped themselves: any one of these polite vagabonds would walk in without the least ceremony, and pour himself out a tumbler of brandy, or whatever else happened to be upon the table; then leave the hut, without expressing a sound or sign of thanks for the honour which he did himself; and as the Frenchmen did not consider it politic to interfere, they had plenty of visitors. Some of the natives understand a little English, which they have acquired from an intercourse with our traders, many of whom make annual calls here to obtain *ivory* and *palm-oil*, (*say slaves*.) About ten o'clock I left the Frenchmen, and took a walk into the town, surrounded by an immense concourse of the inhabitants; some requesting me to sleep at their house, others to come and drink, many haggling for presents, and a few offering them. Amidst this turbulent crew, who became at last rather *hot-pressive*, I could not observe much, and in fact, soon considered it advisable to be off, therefore directed my steps as quickly as possible, towards the beach, which I had some difficulty in reaching. I found the boat lying a little way from the shore, waiting my arrival; upon her landing, all the natives stood some distance back, but immediately the oars were out, they came running to the water's edge, calling in numerous different keys, and modes of expression, to beg I would come on shore again; amongst this variety of sounds, one voice above the rest, said in good English, and rather a sepulchral tone—"If you don't come on shore in the morning, we will come off and murder you all!" This friendly notice did not cause me much uneasiness, such threats seldom being *made* when it is intended to execute them; I therefore considered it as merely intended to alarm us, and determined to make farther inquiry as to the author, it appearing quite evident that none but an English tongue could possibly have given so good a pronunciation. I accordingly went on shore the next day to breakfast: upon my landing, a vast number of the inhabitants were on the beach, waiting my arrival, many with fowls, tortoiseshell, sweet potatoes, &c. for sale, and others merely to gratify their curiosity, which feeling we found as prevalent in the wilds of Africa, as all know it to be amongst the enlightened sons and daughters of Europe. I purchased a pair of beautiful grey parrots, for a yard or two of coarse calico, and a couple of hippopotamus's teeth, for another fathom of the same stuff. After breakfast, I went with my friend the Frenchman to pay a visit to the king, who resides in a part of the town walled in for his seraglio and household. Having arrived at the *palace*, we had to mount a rudely constructed ladder, which required great care in handling to avoid a precipitate retreat; we were then ushered into a spacious levee-room, very neatly built of plank, the walls being partly covered with pieces of looking-glass, and numerous little pictures and prints, most of which were turned *upside down*! He also possessed several chairs of European manufacture: these costly articles were held in great estimation, and were the envy

of surrounding princes! they had been given to him as a kind of bonus, previous to commencing traffic, by the masters of slave and other traders, having in his royal will established it as a law, that no "captain of any vessel shall make trade, until he has paid an introductory or retaining fee!" After waiting in this room a few minutes, his majesty entered—without a flourish of trumpets! His royal niggership appeared verging on sixty, extremely stout, and suffering greatly from elephantiasis, each of his legs being the size of a moderate man's body. The whimsicality of his costume produced, I fear, an evident commotion in my risible faculties, which I was apprehensive might hurt the royal feelings: it was composed of a long coarse robe, or piece of cloth, which after the manner of the cobbler's stall, served him for jacket, for waistcoat, for trowsers and every thing. This garment of many occupations was wrapped loosely round his corpulent figure, with his bare arms hanging outside, having forced their way out by means of a couple of slits in the cloth; sleeves being too great an effort of ingenuity for the tailors of Feteesh Town. Through an occasional opening might be observed a sad lack of Irish, or if any existed, it was of the same texture and complexion as his face. The majestic head was partly covered by an old brown beaver-hat, with a portion of the rim hanging over one ear, and the front strangely distorted, the hat being squeezed on to a head about twice as large as it was originally intended for. His royal feet were destitute of any covering whatever, not having yet added a pair of shoes to his regalia; this was the whole of his gear, and most probably his wardrobe; the unnatural proportion of his limbs, having prevented him from dazzling our sight by the splendour of his crown jewels, we therefore saw him *à naturel*! It was highly ridiculous to see his efforts at dignity, which certainly terminated in a most ludicrous failure; and from this I am strongly led to suspect, that nature, at least black nature, is not dignified in her unadorned or primitive state. But to continue a description of our interview, his majesty very graciously shook me by the hand, and then conducted me to the head of the room, where seating himself, he desired an attendant to bring me a chair, which being done, a short pause ensued as usual, when he commenced by asking through an interpreter, "what news there was abroad?" This was uttered in a very mild, friendly tone, as if about entering upon a long conversation. I must confess this general question rather puzzled me at first, but feeling confident the inquirer did not know France from America, I answered in the first words that came, to the effect, that nothing new had transpired since the Dutch had taken Holland! He appeared much pleased with this answer, and, I have no doubt, thought I took him for a very well-informed erudite king, as he was evidently gratified at having asked a question that admitted of a reply, and like a wise general, he said no more lest he should lose the laurels he had gained. I now opened my business, by first requiring an explanation of the threat that had been held out on the previous evening, which his majesty expressed much surprise and anger at. The interpreter informed us that he had no doubt this observation was made, in order to alarm us, by a white boy, who had been living in the town for about seven years, and gave me to understand I might see him at the house of a Capt. Brandy. Having been satisfied upon this

point, I next stated my expectation of the ship's arrival in the afternoon, when most probably the captain would pay his most gracious majesty a visit. He observed in answer to this, that he should be very happy to see him, and would supply us with any thing he might require, and the place afforded; here our conference ended, and having again shaken hands we descended the ladder. This kingly personage is, it appears, a great *bon vivant*, and drinks brandy by tumblers full with as much satisfaction as any young lady sips her toast and water. He is also possessed of about three hundred wives, with nearly as many *etceteras*, some of whom, report said, were very fine women; but report here is *black*, and as thick lips and flat noses are the fashion in this part of the world, my curiosity was not sufficiently excited to induce me to risk my head, in order to obtain a peep at the dismal beauties of his harem. I had no other opportunity of judging, as only one antiquated nigger lady,—black, and shining as jet,—entered during my audience, who, I afterwards learnt, was the eldest of his *fair* stock of frail ones. The government of this despot is of the most arbitrary nature, and he takes off heads for the most trifling offences; nay, I was informed that, when in the humour, he is not very particular whether the unfortunate victim has committed any. He has one very striking peculiarity for majesty, which is, a great delight in performing with his own hand the part of executioner;* whether this arises from principles of economy, or a natural taste for such refined amusements, I am not able to determine; but this *kingly jack-ketch* frequently decapitates half a dozen of his *loving* subjects before breakfast. His sway extends over a very large territory, which produces a great quantity of ivory, tortoiseshell, and every description of tropical fruit. The town is situated on the right entrance of the river Nazareth, and contains about three hundred houses neatly built of cane; the inhabitants are all armed with either a spear or musket, which latter they obtain from the traders, and much value. Buffaloes are very numerous in the neighbourhood, together with elephants, lions, tigers, and other wild beasts, while the bay abounds with plenty of fish, and its shores with birds of beautiful plumage.

I had the white boy, mentioned by the interpreter, brought to me at the house of the Frenchman; he appeared about fourteen years of age, born of English parents. The account given by himself was, "That he had come out in a merchant ship, where he was very badly treated; this induced him to run away, and getting into the woods he remained there until the vessel left; he then came into the town and told his story to the king, who put him under the care of a Capt. Brandy, by whom, as well as the rest of the natives, he had been, and still was, treated with the greatest kindness. He spoke the native language, and had in fact assumed the dress and manners of the inhabitants in every particular, having like them no covering, but a small piece of cloth fastened round the loins. I tried to persuade him to come on board, and return to England in the ship, but without success, as

* This, in a country where the expenses of the state call for retrenchment, would be a great annual saving, worthy the attention of a certain calculating *Member of Vulgar Fractions*, whose eloquence and talents have found their level in an accurate knowledge of subtraction, and upon whom it is proposed to confer the rather humorous degree of *L. S. D.*!

nothing would induce him to leave these people who had treated him so kindly.

Having had my gun brought on shore, I walked into the woods, with dozens of the natives at my heels, to see if I could procure some *rara avis*, as an addendum to my humble boat fare; but having beat about for some hours without any success, I steered my course towards the boat. On my way—disappointment having, I suppose, made me pugnacious—I saw several monkeys, who all commenced chattering in the most provoking manner, as if in derision of my empty game-bag; I bore it for some time like a philosopher, but at length losing all patience, and having forgot my former resolutions about humanity, monkeys, &c. I raised my gun in order to pepper one young rascal, who, I fancied, was pursuing me with his impertinence; and in the malice of my heart, I had resolved to have the fellow hashed, and eat him out of revenge. Just as I was about to pull, one of the natives knocked down my arm, begging at the same time that I would not fire, saying, “No shoot, dat me God, dat me Feteesh!”—This saved master pug from mixing in the society of pickled walnuts, and me from partaking of hashed monkey. I afterwards learnt that these people worship this animal, as one of their principal Feteesh, and trust greatly to it in any matter relating to life or death; the consequence of this respect being paid them is, that they lose all fear, and never meeting with injury from mankind, are much more domesticated than those which are subject to their cruelties. Upon my return to the town, after shaking hands with about 200 of the natives, a work of some time, I contrived to reach my boat, and shortly afterwards perceived the Barracouta standing down; I therefore got under way, and in about three hours arrived on board.

The following morning Capt. Vidal went on shore, to visit the king; upon his return we made sail, and stood across the bay towards Cape Lopez; the wood is very thick near this Cape, but the trees mostly deciduous, on account of the swampy soil in which they grow: this induces me to think the country about here is very unhealthy, but the natives contradict it. We sent a party brooming, and another to cut wood, for which this place is particularly convenient. Various beautiful shells were picked up by several of the people employed on shore; and one of our young gentlemen observed a large alligator. The entomologist would find much at this place to attract his attention, but our short stay allowed no time for collecting. The principal object of our again visiting this Cape was to obtain some necessary observations; which having done, we again stood over towards the town, and anchored near the French brig, about four miles from the shore. We sent boats away to survey the river Nazareth, which runs through a very fertile country, and empties itself into this bay near Feteesh Town. A boat was also sent on shore to obtain stock; one of the crew produced a knife before the natives, that appeared to strike their fancy immediately. The man offered it for some fowls, upon which it was handed over for examination, when they commenced passing it from one to the other with rather suspicious quickness, and suddenly a fellow from the mob started into the bushes. Jack not seeing his knife, suspected instantly that he had carried it off, so without any hesitation gave chase, and after a short time returned leading the culprit by the ear,

which he called *collaring*, with the stolen property in his hand: first giving him a short lecture upon the impropriety of his conduct, which was like throwing pearls to swine, he next deprived him of the knife, and then commenced hammering his thick hide with a hearty good will, until he was tired, when he allowed him to depart apparently not much *blacker* than when first caught. This wholesome correction was a salutary lesson to the others, and was not the first occasion upon which we found a rogue amongst honest men: the following instance in particular came under my own observation. Whilst in Delagoa Bay, on the east coast, numbers of the natives would come on board daily and form a regular market, bringing all descriptions of stock, which they bartered with the crew, when we sometimes had above an hundred on board at the same time. Upon one occasion as a canoe was leaving us, crowded with natives going on shore, some of their countrymen were looking over the ship's side at them; one of these spectators, whilst speaking to a friend in the canoe, observed something bright in the tye* of another; he instantly descended to the boat, and very soon had a fellow handed on board, upon whom we found a part of the copper hinnacle lamp, which had been lying somewhere near the compass-box: the whole of the people from the canoe immediately returned, and about sixty of them fell upon the culprit with any thing that came to hand, and would very soon have dispatched him to the other world, or rendered him of no use in this, had not Capt. Owen humanely interfered to stop their desperate castigation.

H. B. R.

(To be continued.)

STAND FOR A MERCURIAL HORIZON.

I BEG to recommend for the consideration of persons in the habit of using the mercurial horizon, a contrivance that suggested itself, and was found from long experience and repeated trials to be most useful, it having been the means of procuring many observations that might otherwise from unavoidable obstacles have been lost.

It consists of a piece of lead nine inches long, by seven and a half wide, and half an inch in thickness, having three legs, each about an inch in length, to stand upon, and placed as per figure.

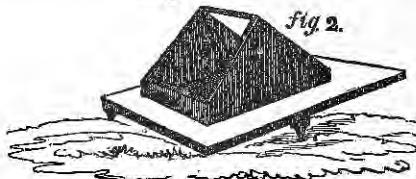
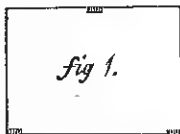

By which means, however uneven the ground, a place will immediately be found for placing it nearly on a level: in soft or sandy soil, also, it forms a firm bed; and the upper part being covered with chamois leather or cloth, entirely prevents any air from affecting the mercury, as well as any dew appearing on the glasses, from the effect of the sun's rays over a damp surface, as is too often the case when the cover is placed on the ground.

THOMAS GRAVES, Lieut. R. N.

* Tye, the piece of cloth worn round the waist is so called.

A RECENT VISIT TO SEVERAL OF THE
POLYNESIAN ISLANDS.

BY GEORGE BENNETT, MEMBER OF THE ROYAL COLLEGE OF SURGEONS
IN LONDON, &c. &c.

DURING a recent visit to several of the beautiful islands of Polynesia, I recorded all the information that I could collect respecting them, and my observations thereupon. The following sketches are an attempt to describe what I beheld of the scenery of these islands, together with the manners, customs, manufactures, &c. of the people. Formerly I had read much respecting the South-Sea Islands, and their scenery, productions and inhabitants, as described in the various works that I perused, captivated my imagination. I had previously visited several parts of India; I had witnessed many remarkable scenes, and the impressions that remained on my imagination were very vivid; the scenery, the inhabitants, oriental pomp and splendour are too captivating to be easily forgotten; but when my route extended to Polynesia, when I viewed its scenery, peculiar customs of the people, the ship crowded with natives, their arts, manufactures, &c. how different were these impressions!

The importance of these islands as respects their capability of producing those articles of commerce which are peculiar to tropical climates, has not sufficiently excited the attention of the mercantile community of Great Britain. As by our commerce we have attained that prosperity which ranks our country so high among European nations, every subject, which is connected with it, ought to be considered of importance; the commerce of the Sandwich Islands alone, by the industry and perseverance of the enterprising people of the United States of America, is calculated at a million and upwards of dollars annually, and may be considered to be gradually on the increase. This commerce, through our neglect, has for years been enjoyed solely by the American merchants; even now, excepting two or three mercantile speculators, but of trivial importance, who are British subjects, the trade is exclusively confined to the merchants of the United States, who have laudably permitted no opportunity to escape by which their commerce might be extended, and it is gradually now on the increase over the Polynesian Islands. Not only in a mercantile point of view are the Sandwich Islands of importance; their geographical situation renders them an acquisition when politically considered, more particularly since the South American States have gained their independence. The Americans view those islands with a jealous eye, and dread seeing them in the possession of a foreign power; they are well aware of their importance, and the visits of their ships of war for the purpose of keeping up a close intercourse with the king and native chiefs has become of late very frequent. The following account of the visit of the American ship of war *Vincennes*, with the accompanying document sent by the Government of the United States to the King of the Sandwich Islands, sufficiently demonstrates the interest taken by them in these islands.

“The ship of war *Vincennes*, Capt. Finch, arrived at Hilo Hawaii, on the 2nd, and at Honolulu, Oahu, on the 14th of October. (1829)

On the 15th Capt. Finch and his officers met the king and chiefs at the palace of *Kauikeoauli*, where they were gratified with a friendly reception.

The commander of the *Vincennes* then read a communication of his own to the king, and gave him both the original and a translation in the native language. He then read also the communication from the President of the United States to the King of the Sandwich Islands, which he had brought; the same being read also from a translation into the native language, was delivered into the hands of the king.

This being finished, Capt. Finch delivered the presents which the President had sent. A pair of globes, terrestrial and celestial, and a map of the United States, to the King. A silver vase to *Kaahumanu*, with her name and the American arms upon it. Two silver goblets to *Nahienaena*, with her name and the American arms. A map of the world to Governor *Boki*; and also a map of the world to Governor *Adams*.

The following are the above named communications which are now published by the request of the King and Chiefs, and with the consent of Capt. Finch.

KING TAMAAAMAHĀH :—The President has confided to my care a written communication for yourself, and such counsellors as you rely upon; accompanying it with various presents for each; in testimony of the good opinion he entertains for you individually, and to evince his desire for amity and confidence, in all intercourse that may subsist between your people and my countrymen.

That the genuineness of the letter may not be questioned, which might have been the case, if the transmission had been intrusted to casual conveyance; and to make it the more honourable to yourself, he has dispatched a ship of war for this and other purposes; and it is enjoined upon me as the commander, to deliver it in person into your keeping; to reiterate the expressions of good will which it contains; and to exhibit by my own deportment, the sincerity of the motives which has actuated him.

The friendly and kind reception afforded to one other national ship, the *Peacock*, has been most favourably represented by her commander, and doubtless has conducted greatly to the visit which I now make.

The improving state of your people has also been so interestingly described by one of your friends, Rev. Mr. Stewart, now beside me, as to awaken among my countrymen at large, great benevolence of feeling towards you; and it will be my duty, and I trust I shall be warranted on my return among them, to strengthen their prepossessions in your favour, and to confirm the accounts of the good traits of character of our new acquaintances the islanders, subject to your authority.

With your leave I will now acquit myself of the pleasing duty devolving upon me, by reading and handing the document adverted to, which illustrates the light in which the President wishes to hold your nation, and upon which you will, I hope, ponder often, deliberately and fully.

The presents I also ask permission to distribute amongst those of your faithful friends for whom they are intended, trusting that they will tend to enlargement of knowledge, invite to social and rational enjoyments; and farther, secure enduring recollections of the assurances which I give of the disinterested friendship of the President and Government of the United States, and of their inclination to perpetuate the peaceable condition, happiness, and well-doing, individually and collectively, of those who by your wisdom are supported; and whose support will increase by a sense of their necessities and your justice.

14th October, 1829.

W. B. FINCH.

TO TAMHAMEHA III. KING OF THE SANDWICH ISLANDS.

Navy Department of the United States, City of Washington,
20th January, A. D. 1829.

By the approbation and direction of the President of the United States, I address you this letter, and send it by the hands of Capt. William Bolton Finch, an officer in our Navy commanding the ship *Vincennes*.

Capt. Finch also bears to you from the President certain small tokens of regard, for yourself and the chiefs who are near to you, and is commanded to express to you in his name the anxious desire which he feels for your advancement in prosperity and in the arts of civilized life, and for the cultivation of harmony and good will between your Nation and the people of the United States. He has heard with

admiration and interest of the rapid progress which has been made by your people in acquiring a knowledge of letters and of the true religion—the religion of the Christian's Bible. These are the best and the only means by which the prosperity and happiness of nations can be advanced and continued, and the President and all men everywhere, who wish well to yourself and your people, earnestly hope you will continue to cultivate them, and to protect and encourage those by whom they are brought to you.

The President also anxiously hopes that peace, and kindness, and justice, will prevail between your people and those citizens of the United States who visit your islands, and that the regulations of your Government will be such as to enforce them upon all.

Our citizens who violate your laws, or interfere with your regulations, violate at the same time their duty to their own government and country, and merit censure and punishment. We have heard with pain that this has sometimes been the case, and we have sought to know and to punish those who are guilty. Capt. Finch is commanded diligently to inquire into the conduct of our citizens, whom he may find at the islands, and as far as he has the authority to ensure proper conduct and deportment from them.

The President hopes, however, that there are very few who so act as to deserve censure or punishment, and for all others he solicits the kindness and protection of your Government, that their interest may be promoted and every facility given to them in the transaction of their business. Among others he bespeaks your favour to those who have taken up their residence with you to promote the cause of religion and learning in your islands. He does not doubt that their motives are pure and their objects most friendly to the happiness of your people, and that they will so conduct themselves as to merit the protecting kindness of your Government. One of their number, the Rev. Charles Samuel Stewart, who resided for a long time with you, has received the favour of his Government in an appointment to an office of religion in our Navy, and will visit you in company with Capt. Finch.

The President salutes you with respect, and wishes you peace, happiness, and prosperity.

[L. S.]

SAMUEL L. SOUTHARD,
Secretary of the Navy.

The missionaries at the Sandwich Islands are now solely Americans, and all communication with the government being carried on through them as interpreters, all their acts must naturally tend to benefit that country alone of which they are citizens. Civilization and commerce will gradually advance, if the first undertakings in the latter are not commenced on too extensive and too expensive a system. The value now attached to coco-nut oil, since the late valuable discovery of its capability of being manufactured into candles, will render it an extensive article of commerce, and the tree is abundantly produced over nearly the whole of Polynesia; varieties of flax, Bêche de mer, tortoise-shell, &c. are now procured, and, by attention, sugar, cotton, and other tropical produce might be readily cultivated; the sugar manufactured by Mr. Bicknell and my friend Mr. S. P. Henry, at Tahiti, was of a superior kind and of a remarkably fine flavour, and affords an instance of what these islands are capable of producing.

A great benefit would be conferred on the navigators of the Southern Pacific, studded as it is with an infinite number of islands, reefs, &c. and the anxiety and danger would be diminished, if the British Government would send annually a small vessel of war from Sydney, for the purpose of surveying and ascertaining accurately the positions of the various islands, groups of islands and reefs. The number of new discoveries annually made by the English and American whalers are very numerous, but the situations as laid down by them, are seldom to be depended on. A vessel appointed for the

purpose of survey should touch at Oahu, Sandwich Islands, and Bay of Islands, New Zealand, those being the principal ports of resort for the whalers and other vessels frequenting this sea; every information respecting recent discoveries could be readily obtained at those places, and of which, during my visit to the former port in December 1829, there existed a long list, most of which were not to be found in the charts. A surveying vessel might also correct the latitude and longitude, which are generally very inaccurately laid down in the existing charts, of the various islands they might visit, and estimate the commercial advantages to be derived from an intercourse with them. It is for the "Ruler of the Ocean" to take the lead in enterprises of this description; it is for him to render that navigation safe where his flag predominates, and where commerce can be extended it ought to be ever found. It is therefore to be hoped, that the British Government will turn their attention to such a desirable object, and this dangerous sea be rendered safe to the navigator.

I commence with an account of Independence Island, followed with that of Rótuma, one, I believe, but little known, and of which no description, to my knowledge, has been hitherto published; these will be followed by others forming part of the New Hebrides Group, &c.

INDEPENDENCE ISLAND.

On the 19th of February 1830, this island was in sight about 10 A.M. bearing south-south-east, and at noon it bore south by east. It is small, but densely wooded, and one of those apparently risen from the labours of the industrious but minute tribe of Zoophytes. About 2 P.M. when but a few miles distant, a boat was lowered, and I accompanied the Commander for the purpose of landing and inspecting its productions. We were soon in with the south-west point, but found a landing there impracticable on account of the surf, which broke with tremendous fury over the coral rocks. We pulled round the island with the expectation of finding some opening by which the boat could enter and a landing be effected; no place, however, could be found; a heavy surf rolled over the rocks, by which the island seemed to be surrounded, and which had a reddish colour occasioned by the growth on them of a species of coralline. On the south side of the island, there seemed to be an opening between the rocks, by which a boat might enter when the surf was moderate, but at this time it raged with so much fury, as to render an attempt dangerous. After pulling round the island, and finding the impossibility of effecting a landing, we returned on board. The island is, I should suppose, about two or three miles in circumference, uninhabited excepting by a multitude of various kinds of oceanic birds, among which the magnificent man-of-war hawk, Pelicanus Aquila, and the Booby, Pelicanus Sula, were most numerous, the island affording them an excellent place of refuge for the purpose of incubation, seldom or never disturbed by man. The beach is bold and sandy, and the numerous trees impart a verdant and beautiful appearance to this otherwise insignificant coral reef; some of the trees being of lofty growth, causes the island at a distance to have a slightly elevated appearance, which it does not possess. Among the trees, I could only recognise the Pandanus. Turtle abounded in great quantity on the reefs, and if a landing were

effected, a quantity could no doubt be obtained, which would be valuable as a refreshment for the numerous whalers and other ships frequenting this sea. During the time the ship lay off and on, a bank of coral rocks was discovered by Mr. W. Warden, the chief officer, on which soundings were obtained of from twelve to seventeen fathoms, the centre of the island then bearing south-west, about four miles distant. This island was made by our observations in latitude $10^{\circ} 41'$ south, and longitude by chronometer $179^{\circ} 15'$ east. It is placed in the late charts in latitude $10^{\circ} 25'$ south, longitude $179^{\circ} 0'$ east. Our observations we consider correct, as on the day preceding, (Feb. 18th,) Mitchell's group was seen bearing from south by east to south-south-east, about seven or eight miles distant, and on the second day, (Feb. 21st,) we made the island of Rótuma. Independence Island was discovered a few years ago by an American ship, whose Commander so named it. When at Rótuma, I saw an American who had left a whaler and was residing there; he informed me that he had visited this island, and described its appearance accurately; he gave me also the following information respecting it. The ship to which he belonged having killed a whale off the island, and during the time that she lay-to for the purpose of "cutting in," as it is technically termed, one of the boats went to endeavour to land: the first attempt, from the surf raging with great fury, did not succeed; but on a second attempt, at high water, the surf being quite moderate, they succeeded in discovering a passage between the reef by which the boat could enter, and a landing was effected, (on which side of the island he did not recollect); there was at the time hardly any surf; they procured a quantity of turtle and sea birds' eggs.

THE ISLAND OF RÓTUMA.

This interesting and fertile island was discovered by the Pandora in the year 1791, and has been since occasionally visited by English and American whalers, and a few other ships, for the purpose of procuring water and a supply of vegetable productions, with which it abounds. It is situated in latitude $12^{\circ} 30'$ south, and longitude $177^{\circ} 0'$ east, and is distant about 260 miles from the nearest island of the Fidji group. It is of a moderate height, densely wooded, and abounding in cocoa-nut trees, and is about from thirty to thirty-five miles in circumference. Its general appearance is beautifully picturesque, verdant hills gradually rising from the sandy beach, giving it a highly fertile appearance. It is surrounded by extensive reefs, on which at low water the natives may be seen busily engaged in procuring shell and other fish, which are abundantly produced on them, and constitute one of their articles of daily food. At night, they fish by torch-light, lighting fires on the beach, by which the fish are attracted to the reefs. The torches are formed of the dried spathes or fronds of the cocoa-nut tree, and enable them to see the fish, which they take with hand-nets. It is by these lights that the fish are attracted, but not so in the opinion of the natives, who say, "they come to the reef at night to eat, then sleep, and leave again in the morning." The numerous lights flickering about have a beautiful effect during a dark night, and might resemble the illuminated halls of Pandemonium. On these reefs, an infinite variety of fish is pro-

cured, but generally of small size; a display of colours of the most vivid description, as well as extraordinary forms, also occur amongst them. We made this island on the 21st of February 1830; it bore west by south-half-south, about twenty-five miles distant; at 11 A.M. when close in, standing for the anchorage, we were boarded by several natives, who came off in their canoes, and surprised us by their acquaintance with the English language; this it seems they had acquired from their occasional intercourse with shipping, but principally from the European seamen, who had deserted from their ships and were residing on the island in savage luxury and indolence. One of the natives acting as pilot, we rounded the islets named Owa by the natives, and anchored in Onhaf Bay, (which is situated on the north-east side of the island,) in fifteen fathoms, sand and coral bottom, about two miles distant from the shore. When at anchor, the extremes of the land bore from east by north to west by compass. An island rather high, quoin shaped, and inhabited, situated at a short distance from the main land, (between which there is a passage for a large ship,) was at some distance from our present anchorage, and bore west-half-north by compass; it was named Ouer by the natives. Close to us were two rather high islands, or islets, of small extent, planted with coco-nut trees, and almost connected together by rocks, and to the main land by a reef; they shelter the bay from easterly winds. Their bearings are as follow:—the first centre bore east-half-north; the second centre bore east-half-south, extreme of the main land east-south-east by compass. One of the chiefs, on our anchoring, addressing the Commander made the following very humane observation, “If Rótuma man steal, to make hang up immediately.” Had this request been complied with, there would have been a great depopulation during our stay, and it is not improbable that a few chiefs might have felt its effects.

On a second visit to this island in March 1830, we anchored in a fine picturesque bay, situated on the west side of the island, named Thor, in fourteen fathoms, sand and coral bottom, about three miles distant from the centre; but I should strongly recommend ships not to anchor here during the months of February, March, April, and the early part of May, the prevailing winds blowing strong from west and north-west, which we had the misfortune to experience, being driven on shore during a gale on the 30th of March, an account of which will be given in the course of the narrative. Ships should prefer lying off and on at the lee-side of the island, where they will be able readily to procure their supplies. A reef extends out some distance from the beach at this bay, almost dry at low water, and with much surf at the entrance, from which cause the procuring of wood and water is attended with more difficulty than at Onhaf Bay. There is another place on the south side of the island named Fangwot, the residence of the king, or principal chief. It affords anchorage for shipping, but from its exposed situation, a ship should prefer lying off and on to anchoring; this is the best part of the island for procuring a large supply of provisions. About five or six miles distant from the main land to the south-west, are several small uninhabited islands, or islets, which are occasionally visited by the natives from the main, for the purpose of procuring from and in their vicinity, shell and other fish. These islets bear the native appellations of Ofiwa, Athana, Hotbahoi; and a rock

or rocks above water, on which the sea breaks, named Hoth-fakteringa. The first has a remarkable appearance, resembling a rock divided in two portions, excepting at one part, where they are joined by a portion of rock forming a natural bridge. The following diagram gives the appearance of the island, bearing west-south-west, about five miles distant; it has a verdant appearance, with several coco-nut trees growing on the summit.



The others have nothing remarkable in their appearance.

On landing, the beautiful appearance of the island was rather increased than diminished; vegetation appeared most luxuriant, and the trees and shrubs blooming with various tints, spread a gaiety around; the clean and neat native houses were intermingled with the waving plumes of the coco-nut, the broad spreading plantain, and other trees peculiar to tropical climes. That magnificent tree the *callophyllum inophyllum*, or *fifau* of the natives, was not less abundant, displaying its shining dark green foliage, contrasted by beautiful clusters of white flowers teeming with fragrance. This tree seemed a favourite with the natives, on account of its shade, fragrance and ornamental appearance of the flowers. When one was cut down by the carpenter of a ship, a young tree was brought and planted close to the place where the old one formerly displayed its wide spreading branches, thus showing a desire of securing for posterity a similar shade and fragrance to that afforded by the one which had fallen; an example well worthy of imitation in every country. When I extended my rambles more inland, through narrow and sometimes rugged pathways, the luxuriance of vegetation did not decrease, but the lofty trees, overshadowing the road, defended the pedestrian from the effects of a fervent sun, rendering the walk under their umbrageous covering cool and pleasant. The gay flowers of the *hibiscus tiliaceus*, as well as the splendid huth or *Barringtonia speciosa*, covered with its beautiful flowers, the petals of which are white, and the edges of the stamina delicately tinged with pink, give to the trees when in full bloom a magnificent appearance; the *hibiscus rosa-chinensis*, or *kowa* of the natives also grows in luxuriance and beauty. The elegant flowers of these trees, with others of more humble and less beautiful tints, everywhere meet the eye near the paths, occasionally varied by plantations of the *ahan* or taro, *arum esculentum*, which, from a deficiency of irrigation, is generally of the mountain variety. Of the sugar-cane they possess several varieties, and it is eaten in the raw state; a small variety of yam, more commonly known by the name of the *Rótuma* potato, the *ulé* of the natives, is very abundant; the *ulu* or bread-fruit, *pori* or plantain, and the *vi*, (*spondias dulcis*, Parkinson,) or Brazilian plum, with numerous other kinds, sufficiently testify the fertility of the island. Occasionally the

mournful toa or casuarina equisetifolia, planted in small clumps near the villages or surrounding the burial-places, added beauty to the landscape. A few days after my arrival I by chance visited a spot which formed a combination of the picturesque and beautiful. I had passed through a village named Shoulnan, and having ascended a hill overshadowed as usual by magnificent trees, I descended towards the beach, when a beautiful view appeared before me; it was a tranquil piece of water formed by the sea, on one side inclosed by a high island covered with coco-nut and other trees, and nearly joining the main land, leaving on each side small passages for canoes, one opening rather more extended than the other; the opposite banks were covered with native houses, intermingled with trees and various kinds of flowering shrubs: the placidity of the water, the tranquillity that reigned around, interrupted only occasionally by the chirping of birds, produced an effect approaching enchantment. After remaining for some time viewing with mingled admiration and delight this interesting spot, I left it with regret; it is situated on the south-east part of the island, and named Shaulcopé by the natives. I subsequently visited this tranquil piece of water in a native canoe; as we passed through the openings before mentioned, the natives commenced singing a monotonous but pleasing song, (consisting of a sentence frequently repeated,) keeping accurate time with the strokes of their paddles; the effect as the voices reverberated around, could be felt, but cannot be described.

The native houses are very neat; they are formed of poles and logs, the roof being covered with the leaves of a species of sagus palm, named hoat by the natives, and highly valued by them for that purpose on account of their durability; the sides are covered with the plaited sections of the coco-nut branches, which form excellent coverings. They have commonly two entrances, one before, the other behind; these entrances are very low, and have a door hung horizontally, which is raised and kept open by a prop during the day, but closed at night. The houses are kept very clean, the floors being covered either with the plaited branches of the coco-nut tree, or the common kind of mat, named ehap, most commonly the former. Near their houses they have generally some favourite trees planted; the tobacco plant also, recently introduced, flourishes luxuriantly, but as yet they have not learned the art of preparing it. The landing is easy, on a sandy beach. Fire-wood can readily be procured at a short distance from the beach; the water is of excellent quality, but from there being no running streams, (excepting a few of very trivial importance situated inland,) the supply is procured from wells.

The natives are a fine-looking and well-formed people, resembling much those of Tongatabu in their appearance; they are of good dispositions, but are much addicted to thieving, which seems indeed to be a national propensity; they are of a light copper colour, and the men wear the hair long and stained at the extremities of a reddish brown colour; sometimes they tie the hair in a knot behind, but the most prevailing custom is to permit it to hang over the shoulders. The females may be termed handsome, of fine forms, and although possessing a modest demeanour, flocked on board in numbers on the ship's arrival; their garrulity when there sufficiently prove that even in this remote part of the globe, there was no deficiency of volubility of the lingual organ, amongst the *fair* portion of the creation. The

women before marriage have the hair cut close and covered with the *shoroi*, which is burnt coral mixed with the gum of the bread-fruit tree; this is removed after marriage and their hair is permitted to grow long, but on the death of a chief or their parents it is cut close as a badge of mourning. Both sexes paint themselves with a mixture of the root of the turmeric plant (*curcuma longa*) and coco-nut oil, which frequently changed our clothes and persons of an icteroid hue, from our curiosity to mingle with them in the villages—*theirs* to come on board the ship. This paint, which is named *Rang* by the natives, and which is also the appellation of the turmeric plant, is prepared in the following manner:—The root of the turmeric, after having been well washed, is rasped into a bowl to which water is afterwards added, it is then strained, and the remaining liquor is left some time for the fecula to subside; the water is then poured off, and the remaining fecula is dried and kept in sections of the coco-nut shell or in balls; when required for use it is mixed with coco-nut oil, and when recently laid on has a bright red appearance, which I mistook at first for red-ochre.

(To be continued.)

ON THE EQUIPMENT OF THE BRITISH INFANTRY.

THE reputation of the British infantry stands high among the nations of the earth, and the ideas of excellence and perfection are so intimately connected, that we frequently hear it stated, that this infantry is susceptible of no farther improvement. To differ from public opinion must at all times subject the writer to considerable obloquy; and we find that the Newtonian theory was at first reckoned by many nothing less than the dream of a madman. Yet notwithstanding these difficulties, I shall now proceed to state what I conceive to be the imperfections of our system.

The first view in which the infantry soldier presents himself to our notice, is as that of a *beast of burthen*, loaded with more than his strength enables him to carry; or if he contrives to wag under it, his powers are so crippled in the day of action, as in a great measure to paralyse his efficiency. How many thousands sunk under their load in the Peninsular war? The Duke of Wellington, the Commander of the Forces, or any officer who served there, may answer the question. The fact I believe to be as clear as any axiom in Euclid, and therefore I take it for granted will not be disputed. The next question that naturally follows is, how is this to be remedied? As I conceive the object to be practicable, I shall now point out what appears to me to be the best means of attaining it.

The Musket.—There is no country where the manufacture of arms is so well understood as in England. The beauty and excellence of our arms for sporting are accordingly unparalleled. When a sportsman examines his arm, the first thing he does is to satisfy himself that the action of the lock is quick and easy; that the piece shoots with the necessary accuracy; that it comes cleverly up to sight; that the bend, length, and thickness of the stock suit him exactly; that the weight is precisely what he requires it to be, and that it is well poised in the

hand. If the arm is deficient in any of these particulars, he immediately rejects it as unserviceable. Let us now try the musket by this standard, and we shall find it deficient in every one of them. They may seem trifles to many, to me it appears that the fate of kingdoms depends much upon them; and that the most *extravagant economy* that has ever been thought of, is that of giving inferior arms to troops, even upon the score of profit and loss. A member of the Chamber of Deputies lately produced an English and a French musket, to show the superiority of the latter; and although it seems to have caused some surprise to see such a weapon in such a place, his conclusion was quite correct. But it is not enough that we should be equal to other nations in the arming of our troops, we ought to be decidedly superior to them, because we have the means of being so; and the British musket in its present state can be regarded in no other light than as a reflection upon the age in which we live.

Under these circumstances, as the principles upon which a soldier and sportsman act are precisely the same, I conceive that they should be armed as much alike as circumstances will permit. I would therefore give to the former a light percussion gun, thirty inches long in the barrel, and weighing from seven to eight pounds, which experience has proved to be the most handy for an ordinary-sized man. The calibre to be reduced to twenty-two balls to the pound, and loaded with a dram and a half of the best cylinder powder. The ramrod not to be turned in loading, but used as that of a rifle. Instead of a bayonet, I would recommend a very light rifle sword; for as soon as a bayonet is fixed, accuracy of fire is at an end. Also a light water-proof cover, to be drawn over the barrel, and tied round the small of the stock.

The advantages that would result from the proposed plan I conceive to be the following:—The fire of the soldier would be infinitely more accurate; he would fire three rounds instead of two; he would carry one hundred rounds of ammunition instead of sixty; and by using one and a half drams of good powder instead of six of bad, he would see distinctly what he was about, and not be enveloped in a dense cloud of smoke, so as to be under the necessity of firing at random. Both ranks might also load and fire kneeling, by which means they would be less exposed to an enemy's fire.

I am aware it will be immediately objected by many, that by shortening the musket, the efficiency of the bayonet, that irresistible weapon in the hands of an Englishman, is at once destroyed. In reply to this objection, I may at once frankly state, that I have no great faith in the bayonet. To trust to the bayonet, instead of fire, is to go back to an age prior to the invention of gunpowder. I believe that a superiority of fire will carry everything before it, and that a bayonet charge dare not be attempted against it. I believe also, that what is generally termed a charge, is nothing more than a simple advance of the line, after the effect has been produced by fire: and when a charge does take place, I am satisfied it is the countenance of the troops that produces the effect, and not the bayonet.

Another objection may, perhaps, also be stated to reducing the calibre of the musket. The ball now used of fourteen to the pound, will, no doubt, inflict a more severe wound than one of twenty-two. But we find from experience, that sixty rounds of ammunition is not

enough, and the soldier cannot carry more of that size. In skirmishing, it is fired away in an hour and a half; and at Waterloo some regiments had to stop their fire in the heat of the action: even when a supply is at hand, the difficulty of distributing it to troops in action is very great.

Cartouch-box.—The construction of this, also, appears to me to be very defective. The flap descends to the bottom of the box, and being placed behind the soldier in action, it is with great difficulty he can raise it, so as to get out his ammunition; and as he works in the dark, he frequently pulls out a number of cartridges together, and drops them without perceiving it. The sole use of the flap is to exclude the wet, so that if it descended an inch or so from the top, it would be quite sufficient for that purpose; and the cartouch-box itself ought to be brought in front of the soldier in action, so that he might see distinctly what he was doing.

Serjeants' Pikes.—Posterity will hardly believe, that four centuries after the invention of gunpowder, the non-commissioned officers in the British army were still armed with pikes. In an army of 80,000 men, we have thus a body of between 4 and 5,000, the most intelligent and the most expert in the use of arms, left totally without the means of defence. Considerable improvement might also be made, I conceive, in the clothing of the soldier, by reducing the weight of every article he has to carry as much as possible; as every ounce that can conveniently be taken from him adds so much to his efficiency. All superfluous buckles and belts ought, therefore, to be done away with, as also the grenadier cap, which is but little adapted for a bivouac. Experience has proved, that a blanket is absolutely necessary for a soldier in the field. But a blanket and great-coat are more than he can carry. The Duke of Wellington tried it the year that his army entered France, but it distressed the troops greatly. The latter ought, therefore, in that case to be left behind.

Knapsack.—The French knapsack* is decidedly the best, which opens at the top. One man can thus open it for another without the trouble of taking it off. It is also packed in much less time than ours, and the time required for troops to get under arms depends very much upon that. Every soldier ought to fire at least one hundred rounds at target-practice annually. It requires much practice to make him expert in the use of fire-arms, and still more so to make him sensible of the power of them. According to the Horse-guards' calculation, the efficiency of a regiment can only be increased by increasing its numbers. No computation was ever more erroneous.

The difference in the efficiency of a soldier who is expert in the use of fire-arms, and one who is not so, is so great, that no comparison can be instituted between them. In fine, I conceive that the load which an infantry soldier has to carry, may be reduced by eight or ten pounds, and his efficiency fairly doubled, by arming him in a superior manner. Even upon the score of profit and loss, shillings and pence, so many muskets for a man's life, the problem may perhaps in time be deemed worthy the solution of the government. MILITARIS.

* The Knapsack invented by Captain Heise, of which we gave a detailed account in a former Number, appears to us to obviate more of the defects generally complained of, and to combine more recommendations than any other with which we are acquainted.—Ed.

DISTRIBUTION OF LIGHT CAVALRY AND INFANTRY
IN THE FIELD.

BY VANGUARD.

I DERIVED much satisfaction from the perusal of an article in the United Service Journal for the month of May, by your correspondent W. in reply to some observations of mine on the comparative merits of the lance and fusée for light cavalry; on the necessity of organizing corps of *chasseurs à cheval*; and on certain alterations being made in the fire-arms of the light dragoon; by which I find that the system for which I have ever been so great a stickler has actually been adopted within the last two years; and that when again called into the field, our cavalry will meet their enemy on equal terms, as far as regards fire-arms and dismounting to act as light infantry, if required to do so.

Without taking great credit to myself, I will avow that my opinions on this subject have not been borrowed, but that experience has many a long year since convinced me, that in having neglected formerly to arm and organize our light dragoons in the manner recently introduced, they laboured under great disadvantages, and had not fair play at the out-posts, when removed at any distance from the support of the infantry; which, during the last war, was often unavoidable, and will be so again on very many occasions.

Your correspondent has judged rightly in conjecturing that I am an *Officer of Infantry*; and I will add, that I am an *old Light Division man*. Whether I wore the uniform of the 43rd, the 52nd, or of the 95th rifle corps, (the three British regiments which composed that division,) it is unnecessary for me to declare. This will, perhaps, at once account for my not having known, until so recently informed of it by your correspondent W., that the very inefficient carbine formerly used by our light dragoons has been set aside, and a much better description of fire-arm substituted for it; and, moreover, that the men are now instructed to dismount and to act as light infantry; a system which, however unpalatable it may be to cavalry soldiers, will give them a confidence in their own strength at the out-posts, when unsupported by infantry, which heretofore most assuredly they could not always have felt. Your correspondent has misunderstood me in one point, on which I am sure he will allow me to set him right.

In alluding to the kind of horse best adapted for *lancers*, I observed, if it was not intended to employ that description of cavalry at out-post duty, but to hold it in reserve for the purpose of acting in more compact bodies, my own humble opinion was, that their *charge* would be much more formidable if they were mounted on the same class of animals as those used by our heavy dragoons, instead of those of a *slighter sort*, such as a few years since were certainly much the fashion in our hussar and lancer regiments. I am happy to find that it is intended to give both hussars and lancers a stonter horse than that hitherto in use; and I will candidly confess, that I was not until now aware of its being in contemplation. We of the infantry, are either not informed of all the changes which take place in the rules and regulations for the cavalry, or we do not give them much attention, I fear, if we are made acquainted with them. The same observation equally applies with regard to the change of tactics in the infantry. Few cavalry offi-

cers, I fancy, give themselves much trouble on that score. All that can be said therefore on both sides is, *the more is the pity.*

Your correspondent W. is undoubtedly aware, that during the whole of the war in the Peninsula, the light division had a front seat in the play; and, that we were so frequently at the *elbows* of those inimitable regiments of light cavalry, the 1st German hussars, the 14th and 16th light dragoons, (more particularly with the two former) and so constantly intermixed with them on pickets, and a multiplicity of duties which fell to our lot as light troops, that a man with common observation could not shut his eyes to the glaring fact, that the fire-arms of the French *chasseur*, and his capability of acting on foot in cases of emergency, gave him vast advantages over our light dragoons at the out-posts. In this school, then, did I catch that smattering of the duties of cavalry in the field, for which your correspondent has been pleased to give me credit. It is satisfactory to me to find that the view which I have taken of the *lance*, from the first moment of its introduction in the British army, coincides not only with the opinion of many experienced officers in our own army, but moreover with that of the highest authorities in the French. I think it the duty of every soldier to communicate any plans which may suggest themselves to him as likely to prove beneficial to the service; although it must be confessed, that nineteen times in twenty it is a most thankless undertaking. Having premised thus much, I beg leave to offer a few hints, picked up here and there during a tolerably long apprenticeship in the army.

It was very generally the custom in the last war, although I am aware that there were exceptions to the contrary, to brigade the heavy cavalry together, and, in like manner, the light.

It has, however, frequently occurred to me, that brigades consisting each of two regiments of heavy dragoons and one of light, would be an arrangement worth the consideration of our cavalry chiefs, in the event of the British army again taking the field in sufficient numbers to admit of the formation of several separate brigades.

A brigade thus constituted, would, I conceive, be of the most efficient description, and be enabled to penetrate a difficult country when at a distance from the infantry of the army; the light dragoons forming the advance-guard, and clearing the front when an intersected tract of country presented itself, by dismounting a part of that force and using them as *tirailleurs*, if so opposed, whilst the heavy dragoons would be at hand to support them. In the French army it was likewise much the custom to form brigades of heavy cavalry, and also of hussars and *chasseurs*. Gen. Franceschi, for instance, commanded a division composed entirely of light cavalry in 1809, under Marshal Soult, in the north of Portugal, or I am greatly mistaken. Gen. Milhaud's division at Waterloo, on the other hand, consisted of cuirassiers and horse-grenadiers. I shall therefore most undoubtedly be accused of the height of presumption, if I question the policy of *invariably* keeping the light and heavy cavalry *separately brigaded*; more particularly as I have always served with the infantry. Franceschi's light cavalry were admirably suited to the description of warfare likely to be encountered in the rough and mountainous regions of the north of Portugal (if ALL his regiments had been *chasseurs*, the

more easily and effectually could they have been applied); and Gen. Milhaud's heavy cavalry again were much better adapted than any other for trampling down squares of infantry on the plains of Waterloo. Although it was a perfect failure with the latter force, in spite of the most determined and enthusiastic bravery of the French cuirassiers, who were slaughtered in heaps, in their reiterated attempts to annihilate the immoveable British squares of infantry; yet I cannot but think, that taking the whole year round, from the 1st of January to the 31st of December, and one description of country with another, the plan which I have suggested of giving one regiment of light dragoons or hussars to every brigade, may, by possibility, prove worthy of being taken into consideration.

I have a similar proposal relative to the formation of divisions and brigades of infantry, which, I beg leave to observe, is one borrowed from our French neighbours.

After the cessation of hostilities between the armies of the Duke of Wellington and Marshal Soult in 1814, near Toulouse, I made many excursions across the *Tara*, (that river being the line of demarkation between the two armies,) and had frequent communication with French officers. I attended their *company* and *regimental* parades; and I was present when a considerable part of Soult's army, and one or more divisions of Marshal Suchet's, passed in review before the Duke D'Angoulême at Montauban; and highly gratified I was at being enabled to make so minute an inspection of those veterans with whom we had been scuffling and fighting from the Guadiana to the Garonne. I ascertained that *every division*, and in many instances *each brigade of infantry*, had one light infantry battalion belonging to it, independent of the light companies of each battalion of the line; and that this was a rule from which Napoleon allowed no deviation, if it could be possibly avoided. The policy of this system must be so apparent to every military man who has served in the field, as to render any comment on it unnecessary.

Every division of our army in the Peninsula had *one or more* regiments of Portuguese light infantry, (Caçadores,) who soon became very respectable troops; so that they, together with the British light companies of each brigade, furnished a force of light infantry sufficiently numerous and efficient in most cases for the operations of their respective divisions. But it should not be forgotten, that if the British army is again called into the field, the chances are fifty to one against its divisions of infantry being mixed up and chequered with foreign troops in the same manner as was the case with its Portuguese Allies; and it must therefore necessarily rely on its own resources for a due proportion of light troops; which, the practical soldier will not deny, are of the first importance in every situation in which an army can possibly find itself placed.

As we ought not to be too proud to borrow the opinions of an enlightened and experienced antagonist, nor fail to oppose him with his own weapons if we find them formidable, I trust that our light infantry battalions will, in future campaigns, be equally distributed amongst the different brigades and divisions. Should this appear a strange doctrine to emanate from the pen of a light-division-man, let it be borne in mind, that during the six latter campaigns in the

Peninsula, no less than six British battalions of light infantry and rifle-men—viz. 43rd, 52nd, (at one period the 52nd had *two* battalions in Spain,) and the three battalions of the 95th rifle corps—were together; and, although particularly calculated, from their composition and organization, for the arduous duties of the out-posts, advance, and rear-guards, &c. &c. and however laudable the pride which men naturally felt at belonging to a division which, as a matter of course, always held a prominent station in the army; it may be questioned, whether to have given each of the eight divisions an equal proportion of British light troops would not have been desirable.

The Duke of Wellington has since said, or it has possibly been said for him, that in the event of another war on a large scale, he would not form a whole division of light troops, as he considered them too valuable to be kept together. If I am accused of trumpeting the fame of my old division, I flatly deny the charge; yet I will say, that its very name warms the blood, and recalls to mind a thousand scenes not likely to be forgotten. Your correspondent W. gives some useful hints as to the necessity of obliging *each troop* of cavalry to take its turn in performing the duty of skirmishing, instead of selecting a few smart fellows as *standing dishes*, who are invariably called on at *drills* and *field-days* to gallop furiously out to the front, to fire, and to resume their original positions in the line afterwards.

The same observation is applicable to the drill of infantry, where it is too common a custom to cover the *advance* of a battalion, or its *retreat*, invariably with one or other of the flank companies. This may do very well for battalions of the line, but it is a grievous mistake when adopted by light infantry, or rifle battalions, where each company is equally liable, when in front of the enemy, to be called on to perform that duty.

Having taken the liberty of giving an opinion on the comparative merits of the *arms* of light cavalry, I would offer, in conclusion, a remark or two on the weapons of our light infantry.

Some men have not hesitated to object to the rifle, to pronounce it an imperfect arm, and to propose that it should be *entirely abolished* in the British army; assigning as a reason, that it requires more time for the *rifleman* to load after firing, than the *light-infantry-man* with his smooth-bored musket. Admitting that a *very trifling time longer* is required for the rifleman to re-load than the light infantry soldier, still, in ninety-nine cases out of an hundred, *two* rifle shots shall cause more death and destruction than *three* or *four* discharges from a musket, allowing both the rifleman and light bob to be tolerably fair artists in their way. Perhaps the following fact, to which I was an eye-witness, may have a tendency to convince those who are sceptical on that point. A short time before the commencement of the war in the Peninsula, when stationed in Kent with some battalions of the 43rd, 52nd, and 95th rifle corps, notes were compared, and the targets of a rifle company and one of the light infantry were examined on their return to barracks from practice at the target.

The strength of the two companies was equal, being about eighty men each. *Six rounds* had been fired by every man of both parties; the rifle company having its target placed at *two hundred yards*, (the usual distance) and the light infantry company at between eighty and

ninety yards. The *contingent allowance* of the rifle captain suffered severely on that occasion, as the target was so riddled and cut to pieces, that it was with difficulty brought home; whilst the target of the light infantry was, comparatively, in a good state of repair. I have given *time* and place; and, if necessary, I could name the captains of the two companies.

In covering a retreat, I am of opinion that the rifleman should by no means attempt to keep up the same random, and too often, ineffectual fire, which I have often witnessed by light companies; but that if, on the contrary, he takes proper advantage of the weapon he bears, and expends few shots without either *actually hitting* or *going very near his pursuers*, nothing will so much tend to make them keep at a respectful distance, or to cool their ardour. I know of nothing that makes skirmishers mind their business more than being actually opposed to a scattered line of good marksmen.

Before the commencement of the Peninsular war, the commandant of one of the battalions of the 95th rifle corps had *moveable targets* constructed, at which the men practised when adepts at the standing mark. The idea was a capital one; but the ropes affixed to the targets, by which they were pulled and tugged along the sea-beach near Hythe barracks, were continually cut in two by the bullets. The whole corps shortly afterwards found itself in the Peninsula, where moveable targets of another description were found in great abundance, ready made to their hands, at which they had unremitting practice from 1808 to the close of the war in 1815 at Waterloo.

VANGUARD.

THE VETERAN TO HIS SWORD.

DEAR art thou still, my trusty sword,
 Though dimm'd is now thy shine;
 Thou art my soul's last cherish'd hoard,
 My deeds are blent with thine.
 There's rust upon thy gleaming blade;
 The stain will not depart;
 And I have felt the same dark shade:
 But mine is on my heart!

We've fought in many a goodly field
 Amid the combat's yell;
 And proud was I a blade to wield
 Which wrought its part so well.
 Now—thou art but a harmless thing,
 Which women dare to touch,
 And smile, amid their marvelling,
 That men are slain with such!

Back to thy sheath—the day may come,
 That I shall grasp thee yet
 To strike for my own hearth and home,
 Where armed hosts are met.
 What! though our brightest years are o'er,
 Let but the trumpet peal,
 We'll blithely to the fight once more,
 My old, my trusty steel!

P.

YEOMANRY CAVALRY.

WITH REMARKS ON THE REVISED CAVALRY MOVEMENTS.

THE importance of making this description of force thoroughly available and effective, must be evident to all persons, whether civil or military, who reflect that yeomanry are in fact almost the last resource of the magistracy, after all ordinary methods for restoring tranquillity in times of disturbance have failed and been found insufficient, and when, unless yeomanry are at hand, the awful responsibility must be incurred of calling out troops to act against their countrymen. In the U. S. Journal for April, there appeared a letter signed by a field officer of yeomanry, concerning the merits of the revised system of movement which has been on trial for the last two years in the regular cavalry, and expressing his fears lest that system should be adopted also in the yeomanry.

Now, if the experience of an old troop officer of a regiment which has invariably been remarked both abroad and at home for its steadiness and good instruction in the field, may be allowed to weigh in the scale against the twenty years' experience announced by the field officer of yeomanry, it will not be thought presumption to offer a few remarks in reply, particularly as he not only makes some unmeaning criticisms upon the revised system which has been practised for these two last years by the regulars, but also ventures some sneering comments on the efficiency of the commissioned officers of the cavalry, as compared with that of their serjeants and corporals, a subject upon which he is evidently as much in the dark as in his attempts as a field critic.

Whatever may be the decision of the Board, which is shortly expected to assemble and investigate the system alluded to, my brother officers of the cavalry of the line who have practised its principles, have, as far as I have been able to learn, but one voice on the subject. They have found the movements easy to acquire and easy to execute, every point of instruction being laid down in plain language, divested of tactical pedantry, and yet mathematically as well as practically correct, so that it is an officer's own fault if he ever finds himself at a loss at a field-day. Silence and order are of course the necessary consequences, and both young officers and recruits are fit for squadron in half the time they used to be. But to come to a few details, and to show how frivolous and ill-founded are the objections of our yeoman critic, I would in the first place inquire where he obtained his information, that "The officers of regular cavalry, when placed in front, have nothing to do but to dress themselves, and can have no influence upon the ranks behind them, who must be therefore dressed by the non-commissioned officers upon the flanks." Does he then forget, or is he altogether ignorant of the fact, that whether troop officers are in front or on the flank, still, according to all regulations, whether old or revised, the dressing of the squadron when ordered to advance has invariably been to its centre; and for an officer upon the flank of a squadron to call to the men to dress towards him, or by his direction, would be a flagrant violation of the principles of Dundas, who so frequently urges the necessity of all dressing proceeding from that point

to which the eyes of the men are turned, and which, in this case, is of course the centre. To dress the squadron from its two flanks at the same time, on the supposition that the squadron officer cannot see anything of his men, because his back is turned towards them, would have the effect of making him a complete cipher, and frequently of actually disjoining the squadron in its very centre, where of all places it ought to be most solid and compact. We are next informed, that from the circumstance of the yeomanry officers' horses being unsteady, and not well broke, those officers will be disadvantageously placed in front and out of the ranks; and ought, on the contrary, to be in the ranks, and on the flanks of their half squadrons; and then immediately follows the declaration that "the correctness of all movements in column depends on the flank leaders;" from which one arrives at the strange conclusion, that because yeomanry officers' horses are unsteady and unquiet, they will be best placed at those very points where steadiness and correctness are announced to be of such exceeding importance. From what part of his twenty years' experience the field officer of yeomanry has discovered "that the officers of regular cavalry are less efficient than their serjeants," it is not easy to guess; but, before he pays such compliments to the acquirements in the field of his brethren of the regulars, he had perhaps better make himself a little more conversant with their movements, and the principles upon which their execution is made to depend. When he has done this, he will perhaps find out that an officer in front of his men can control them if they rush irregularly forward, much more effectually in his own person than when placed upon the flank, to which the men are ordered *not to look*, and where he can only exert his influence and authority upon the few men immediately next to him; as if any good commanding officer would permit all the flank officers to be bawling to the men during an advance in line, when the utmost silence should be preserved, and no voice ought to be heard but his own and that of the squadron leaders.

The field-officer proceeds in his observations by saying, that a good yeomanry officer does not set his line a galloping till they are steady at their walk and trot. Does he really imagine that this is a discovery peculiar to himself, and that the officers of regular cavalry have not long ago considered this as an established and standard principle of the service to which they belong? He is very right in saying that some yeomanry corps have arrived at surprising perfection in movement; but it certainly admits of much question how far that style of movement to which he alludes is a useful exercise for yeomanry. To go through a number of complicated manœuvres, all written down in a particular routine and order, and prepared for a length of time beforehand for the purpose of accomplishing one brilliant review, performed in strict and pedantic mimicry of the regular cavalry, appears by no means a judicious employment of the short period available for their training. Many a troop of yeomanry has played its part with perfect success in these exhibitions, without a single man or officer knowing the object and intention of the manœuvres they were going through with such "*rapidity and precision*;" and when marching home in high spirits at the encomiums of the reviewing officer, has been grievously

puzzled, officers and all, by having to pass some such unavoidable defile as is caused by an overturned waggon in a confined road, where the common and really useful operation of diminishing their front in a regular and systematic way, and again increasing it after the obstacle was passed, would have obviated all difficulty. But the field-officer would probably disclaim any such simple exercises, and would look upon this and all the other details of what is usually called squadron drill as extremely tiresome, quite beneath the notice of a tactician, and by no means so well calculated for astonishing the minds of spectators at a review, as some grand movement, such as a "*formation of close column right in front facing to the rear at a canter,*" with all the half squadrons curling round in a countermarch like so many great caterpillars, and then scrambling off for their places in column, preceded by a whole flock of markers, led by the adjutant, riding as if his life depended upon it. Let us figure to ourselves the progress of the scene—we will suppose these markers, being even better acquainted with the manœuvre than he who commanded it, are all arrived in safety, and after a great deal of waving to and fro of swords, accompanied by not a few smothered imprecations, finally planted, according to the adjutant's intentions, as pivots of the column. The half-squadrons, meantime, begin to approach, and audible whispers are circulated among the officers of—"Which is my marker?" "When am I to lead?" "Am I to stop short, or go straight up to him?" "Do we go round him?" "Which way do we turn?" "Which is to be the front?" and a thousand other equally agitating questions. For one officer that is answered right by his neighbours, two are answered wrong, but under the protection of a cloud of dust, like the heroes in the Iliad, and being now within reach of their markers, who are generally old soldiers of the line, and on the look-out for the approach of their officers, like pilots off a harbour, the whole bundle into column, and settle down into something like order and regularity; the dust clears away, and there they stand glittering in their glory, while the bewildered spectators declare their unmixed admiration of the splendid manœuvre it has been their good-fortune to behold.

Now, that this picture of a yeomanry field-day of the old school is not overcharged, let any unprejudiced person who may have attended such reviews deny if he can. No ridicule is intended to be thrown upon the yeomanry, whose zeal, intelligence, and patriotic sacrifice of time and expence entitle them to every praise from their fellow-countrymen and brethren of the regulars; but it is merely wished to prove the absurdity of some of their chiefs and instructors in teaching them, as it were, to dance before they can walk, and in accustoming them, as certainly used to be the case, to mistake the performance by rote of a certain series of manœuvres selected from Dundas, and which never yet were, nor ever could be employed by cavalry on service, for that perfection in which the field-officer asserts that two very good yeomanry corps, the Cheshire and Lord Grantham's, were fully equal to the regiments of the line. The practice of the cavalry of the line during the last two years has shown, that among many advantages of placing officers in front of their half-squadrons, it is one of the principal that they have much better control over their men, and can more easily

restrain those who from the impetuosity of their horses, or their own eagerness, are disposed to break the regularity of the line by rushing too forward, a fault which was always too prevalent in the British cavalry, and which not only led to unsteady advances in line, but also to the line being frequently overshot by troops coming up successively in formations to the front, from echelon or open column, as well as in the important manœuvre of deploying. This advantage and the getting rid of a host of markers, which is a main result of having officers in front, have simplified the movements of the regular cavalry to a greater degree than can be at all appreciated by those who have never practised them; at the same time by not employing at field-days that number of detached markers who could not be so employed before the enemy, the evolutions of the cavalry are made more like what they ought to be, namely, a preparation for what is likely to be required of them on real service. Now, every one of these arguments for abolishing the use of detached markers, and for placing officers in a situation to control their men and preserve the lines from being broken and overshot by the unsteadiness of either man or horse, applies with double force to the yeomanry cavalry; not to mention that the officers are spared the difficulty and inconvenience of constantly shifting flanks, to do which at the proper instant, and without making mistakes, was always, even in the best-drilled regiments of the line, one of the most intricate points of the troop officer's field duty, as every one must well recollect who, before the late revision was introduced into practice, served as a subaltern in the cavalry, or who, in the situation of adjutant, has been conversant with the instruction of the young officers. The abbreviated words of command are the next subject of the animadversion of the field-officer, and he carefully explains that no word of command ought to be given to the yeomen with the meaning of which word they are unacquainted; as if it ever were intended or could be thought proper that *unintelligible* commands should be given to any cavalry in the world. The whole object of words of command is to convey a distinct and plain meaning, but is it by lengthy sentences that such meaning is best conveyed? Will not a high wind, or the slightest confusion, affect the circulation of long words of command? Will the squadron officers who repeat them, as easily catch and pass a long sentence as a short one? Are not short commands sooner made familiar to the ear, and such words as are lost in noise or wind more easily supplied by the officers most distant from the commanding officer? Above all, are not common and plain terms better understood by young soldiers than technical and scientific phrases, which seem intended for no other purpose than to make a mystery of an art whose chief merit must always be extreme simplicity? For instance, when a division or troop is to make a partial turn towards its right hand, is it not more in accordance with the ordinary expressions of our language to say "*right,*" followed by "*forward,*" when the division has wheeled as much as is intended by its officer, than to say "*left shoulders forward,*" followed by "*forward,*" in order to accomplish the very same thing? In the latter command, the term "*left*" seems really introduced merely to puzzle the cause. Suppose you lost your way in travelling, and were to ask the first man you met to direct you, would he desire

you to bring your *left shoulder forward* at the next cross road, or would he not plainly tell you to turn to your *right*? There is no need of twenty years' experience in the yeomanry service to solve such a question. Indeed, the field-officer answers it himself better than any one could answer it for him, by observing with much truth, "that it is of little importance how many syllables are uttered by a commanding officer; the only point worth considering is, by what means he gets his commands most efficiently executed."

The words of command in the revised movements lately practised by the cavalry, have certainly a few variations from Dundas, but it will hardly be denied, that such a word as *change front to the left on the second squadron*, is more simple than, "*The regiment will change position to the left, right brought forward, left thrown back, upon the left half squadron of the right centre squadron*"; and since the regiments have found no difficulty whatever, but on the contrary much advantage from the abbreviation of these long and puzzling sentences, and execute their purport quite as efficiently and correctly, there really seems no reason for preferring them to shorter and equally plain commands, especially when Dundas himself, speaking of commands, recommends that they should be—"short, clear, and expressive of what is to be done."

The field-officer concludes his remarks by saying, that "if the yeomanry are inferior to regulars in some things, there is the greater necessity for rendering them more perfect in other things"—and this remark, if properly applied, is an extremely just one, but for yeomanry to aim at this perfection by long and difficult words of command, and still more long and complicated manœuvres, is the very last means of arriving at excellence of any kind. Yeomanry are never wanted in great lines for any purposes except the empty ones of parade. It is in separate squadrons and smaller detachments that their real services are generally required, and if they can execute the simple formations of the troop and squadron readily, and without confusion, to either front, flank, or rear, and can also with equal readiness increase and diminish their front while upon the march at a moderate trot, they will find themselves much more efficient, as a military force in the hour of trial, than they can ever be made from imitating the parade movements and reviews of the regular cavalry, to which, in these matters, their want of habitual practice must always render them inferior, however plausibly they may perform a prepared field-day; while by adhering to those simple exercises above mentioned, they may not only rival the regulars in points which are of the first importance on service, but also will make themselves a truly effective and formidable force, able to render the most essential and valuable aid for the preservation of internal peace, and forming a patriotic and efficient safeguard for the liberties of themselves and their fellow-countrymen.

(Signed) A CAVALRY CAPTAIN.

THE SERVICES OF THE LATE
ADMIRAL SIR JOSEPH SYDNRY YORKE, K.C.B.

THE melancholy event which occurred on the 5th of May, and which deprived Sir Joseph S. Yorke of his life, has been the subject of universal regret, not only in the naval circles, but among all classes where he was known; for it cannot be denied that he possessed feelings actively alive in the cause of benevolence, and which he fully exercised whenever an object at all worthy of his interference solicited his assistance.

It seems that Sir Joseph Yorke had been with Capt. Mathew Barton Bradby, in the latter officer's vessel, of fourteen tons burthen, accompanied by Capt. Thomas Young, on board the *St. Vincent* at Spithead, which ship is fitted for the flag of Vice-Admiral Sir H. Hotham, who is about to proceed to the Mediterranean as Commander-in-chief. On their return, a sudden and violent gust of wind came on in Stokes Bay, which upset the vessel, and all on board perished.* The bodies of the unfortunate sufferers were found, and on the following day, the Coroner held an inquest, when a verdict of "accidental death" was recorded.†

The Admiral was born in London, 6th June 1768, and entered the Navy as Midshipman on board the *Duke*, (98,) Feb. 15th 1780, then commanded by Capt. Sir Charles Douglas, with whom he joined the *Formidable*, the flag ship of Admiral Lord Rodney, and was in the celebrated actions with the French fleet under Comte de Grasse, on the 9th and 12th of April 1782. The peace which was soon after concluded caused Mr. Yorke to return to England, and the *Formidable* being put out of commission, he after a short time joined the *Assistance*, Commodore Sir Charles Douglas, and then the *Salisbury*, Capt. Sir Erasmus Gower, as Master's Mate, and remained on the Newfoundland Station nearly three years.

June 16th 1789, Mr. Yorke was promoted to the rank of Lieutenant, and served with Admiral Sir Richard Hughes on board the *Adamant* of 50 guns. He subsequently served as Lieutenant of the *Thisbe*, and *Victory*, and in the latter during the armaments against Spain and Russia. In February 1791, he was promoted to Master and Commander, and to the *Rattlesnake* sloop cruising in the Channel, until the war with the French Republic commenced. Capt. Yorke was promoted to Post-rank Feb. 4th 1793, and to command the *Circe* frigate, under the orders of Admiral Earl Howe; he was actively em-

* Little doubt exists of the *Yacht* having been struck by lightning.

† Capt. Bradby, who thus lost his life, was the son of Rear-Admiral Bradby, who died on the *Superannuated List* of Admirals in 1809. Capt. Bradby was made a Lieutenant, July 1796, and a Commander, 29th of April 1802. He afterwards commanded the *Calyppo*, of 18 guns, in the North Sea, and was made Post-Captain, June 28th, 1810. He has left a widow, who was daughter of Vice-Admiral Billy Douglas.

Capt. Thomas Young, the other unfortunate sufferer, was made Lieutenant, October 8th 1801; promoted to Commander, November 5th 1806; and to Captain, January 1st 1817.

ployed in the Channel ; and close to Brest harbour, captured *L'Espiegle* corvette.

In August 1794, Capt. Yorke was appointed to the *Stag* frigate, employed in the Channel and North Sea ; and on the 22nd August, the next year, when in company with a small squadron under Capt. Alms' orders, chased two large ships and a cutter, the sternmost of which he brought to action. After an hour's engagement, the vessel struck, and proved to be the *Alliance*, Batavian frigate, of 36 guns and 240 men, several of whom were killed and wounded. The others, which escaped, were the *Argo* of the same force, and the *Nelly* Cutter, of 16 guns. In March 1800, Capt. Yorke was removed to the *Jason*, of 36 guns ; and in the following year to the *Canada*, 74, which he commanded until the peace.

On the recommencement of hostilities, Capt. Yorke received an appointment to the *Prince George*, from whence he was removed to the *Barfleur*, and then to the *Christian VII.* a large Danish ship with round quarters.

On the 21st of April 1805, His Majesty George III. was graciously pleased to confer on Capt. Yorke the honour of Knighthood. This was preparatory to the Installation of the Knights of the Garter, that took place in St. George's Chapel on the 23rd of the same month, and upon which occasion Sir Joseph Yorke went through the ceremonies as the representative of his brother the Earl of Hardwicke, at that time the Lord Lieutenant of Ireland, and therefore incapable of attending at that splendid ceremony.

Upon the appointment of Lord Mulgrave, as Master-General of the Ordnance, in 1810, the Right Hon. Charles Yorke became First Lord of the Admiralty, and Sir Joseph was nominated to a seat at the Admiralty Board, in the room of Capt. Robert Moorsom, and in consequence relinquished the command of the *Christian VII.*

Sir Joseph was promoted to the rank of Rear-Admiral of the Blue, July 31st 1810 ; and in January following hoisted his flag on board the *Vengeance*, 74, in which he proceeded to the Tagus with a large body of troops in transports, to re-inforce the army under Lord Wellington ; he afterwards sailed to the Western Isles, with three sail-of-the-line and two frigates under his orders, for the protection of an homeward-bound fleet from the East Indies.

In the promotion of Flag-officers, which took place 4th June 1814, Sir Joseph Yorke obtained the rank of Vice-Admiral. In April 1818 he resigned his seat at the Admiralty, and held no public situation afterwards.

On the organization of the Order of the Bath in 1815, Sir Joseph Yorke was nominated a Knight Commander. At the promotion which took place on the ascent of his present Majesty to the throne, Sir Joseph Yorke became an Admiral of the Blue, 22nd July 1830.

Sir Joseph Yorke commenced his Parliamentary career in 1790, when he was returned for Reygate, Surry, while he was Lieutenant of the *Victory*. This place he continued to represent until 1806, when he was returned for St. Germain's, in Cornwall, which he vacated in 1810 in favour of his brother.

At the general election in 1812, Sir Joseph Yorke was returned for

Sandwich, but again vacated his seat in 1818; in the same year he was returned for Reygate, which he continued to represent until the recent dissolution of Parliament, and had been re-elected for that place to serve in the New Parliament.

Sir Joseph Yorke married in April 1798, Elizabeth, daughter of James Rattray, of Atherston, North Britain, Esq. by which Lady, who died Jan. 20th, 1812, he had several children, one of whom, Charles Philip, is now Captain of the Alligator frigate in the Mediterranean, and served as Midshipman in the Queen Charlotte before Algiers. Sir Joseph Yorke married secondly, May 22nd, 1813, Urania, Dowager Marchioness of Clanricarde, daughter of George, the twelfth Marquess of Winchester, who survives him. By this marriage there is no issue.

Sir Joseph Yorke was the youngest son of the Right Hon. Charles Yorke, who filled the high office of Lord Chancellor in 1770, and was created a Peer of the Realm, by the title of Baron Morden; but dying before the patent had passed the Great Seal, the Peerage did not take place.

The present Earl of Hardwicke succeeded his uncle in the titles and estates. Both his Lordship's sons, Philip, Viscount Royston, who was lost on board the *Agatha*, merchantship, near Memel, April 7th, 1808, and Charles James, who then became Viscount Royston, and died May 1st, 1810, being the only male heirs, the Earldom devolves on the Right Hon. Charles Philip Yorke, his Lordship's brother, should he survive him, but if not, then it descends to the eldest male survivor of the Admiral's children.

Sir Joseph Yorke was chairman of the Waterloo Bridge Company, in the management of whose concerns he took a very active part.

The last public act of the lamented Admiral's life was the presiding at a meeting at the Thatched House Tavern, on the 29th April, for considering a plan for carrying into effect "A School for the Education of the Sons of Naval and Marine Officers, together with an Orphan Foundation, under the sanction of the King's Most Excellent Majesty," an institution that promises to be of essential service, and which is highly creditable to its projector, Commander Dickson.

The lengthened parliamentary career of Sir Joseph Yorke was distinguished by sound and constitutional views, unflinching zeal for the interests of his profession, and invincible and irresistible good humour. In the tumult of the most stormy debates, his voice was wont to appease the conflicting senate, and restore at least a momentary harmony by the quaint phraseology and shrewd observations he brought to bear upon the discussion. His loss is doubly to be deplored at the present crisis, when his attachment to the constitution, and unswerving honesty, would have rendered him a valuable ally to the cause of rational freedom, and the menaced institutions of his native land.

The remains of Sir Joseph Yorke were deposited in the family vault at Wimple, near Arrington, Cambridgeshire, not far from Wimple Hall, the seat of the Earl of Hardwicke.

THE SERVICES OF THE LATE VICE-ADMIRAL
THE RIGHT HON. SIR WILLIAM JOHNSTONE HOPE, G.C.B.

Few officers of either service have passed through their professional career less marked by the tongue of calumny than the late Sir William Johnstone Hope. This estimable and good man was supposed by many to have been a native of Scotland, which was not the fact, as he drew his first breath at Finchley, in the county of Middlesex, on the 16th August 1766. He is descended from John de Hope, who, it is said, came from France in the retinue of Magdalene, Queen to James V. in 1537. The father of Sir William, was John Hope, a merchant of London, who married Mary, daughter of Eliab Breton, of Enfield, Esq. and was their third son.

At the early age of ten years he entered the Navy, under the patronage of his uncle Capt. Charles Hope, (who was subsequently Commissioner of Chatham Dock-yard, and died September 16th, 1808,) on board the *Weazel* of 14 guns, and accompanied him into the *Hind*, *Crescent*, *Iphigenia*, and *Leocadia*, successively employed in the West Indies, coast of Guinea, North Sea, and Newfoundland. From the latter ship, Mr. Hope removed into the *Portland* of 50 guns, the flagship of Vice-Admiral Campbell, then at Newfoundland. In October 1782, he obtained the rank of Lieutenant, and was appointed to the *Dædalus*. After the peace in 1783, this frigate was paid off; but being again put into commission, Lieut. Hope was appointed to her, and proceeded to the coast of Scotland; but in the following year the ship was paid off at Chatham. After this, Lieut. Hope received an appointment as Flag-lieutenant to Admiral Milbanke, commanding at Plymouth. In April 1786, he joined the *Pegasus*, commanded by his present Majesty, (then His Royal Highness Prince William Henry,) and proceeded to Newfoundland, Halifax, and the West Indies, at which place he exchanged into the *Boreas* of 28 guns, commanded by the gallant Horatio Nelson, from which ship he was paid off at Sheerness in November 1787.

The *Victory* being fitted for the flag of Earl Howe, in consequence of the disturbances in Holland, which were speedily suppressed, Lieut. Hope received an appointment to that ship, but was soon afterwards paid off, and placed upon half-pay.

The *Adamant* of 50 guns being fitted for Sir Richard Hughes, Lieut. Hope was appointed to that ship, and sailed in June 1789 to Halifax, where the Admiral had been appointed Commander-in-chief.

In the following year, Lieut. Hope was promoted to the rank of Master and Commander, and to the command of the *Rattle*, sloop-of-war. In June of the same year, Capt. Knox of the *Adamant*, was compelled through illness to resign the command of that ship, and the Admiral (Sir Richard Hughes,) gave Capt. Hope an order to act in her. Soon after, Capt. Lindsay retired from the command of the *Penelope* through ill health, and Capt. Hope took the command, which appointment was not, however, confirmed by the Admiralty, and he returned home in the *Adamant*, and paid her off at Plymouth in 1792.

Capt. Hope's next appointment was to the *Incendiary* fire-ship, which he commissioned in January 1793, and from which he was on

January 9th, 1794, promoted to the rank of Post Captain, and to the command of the *Bellerophon* of 74 guns, the flag-ship of Rear-Admiral Sir Thomas Pasley, but who then had a broad pendant on board as Commodore, which ship was particularly distinguished in the several engagements with the French fleet on the 28th and 29th of May, and glorious 1st of June 1794. For Capt. Hope's services, he was presented with a gold medal, the same as the other Captains on that memorable occasion, by His Majesty George III.

In March 1795, Capt. Hope having quitted the *Bellerophon* in the January preceding, was appointed to the *Tremendous*, belonging to the Channel fleet; and in May following, at the request of Admiral Duncan, he joined the *Venerable*, the flag-ship of that gallant and heroic officer in the North Sea. In consequence of an accident on the head, Capt. Hope met with on board one of the Russian line-of-battle ships, at that time in company with the British fleet, he was reluctantly obliged to resign the command of the *Venerable*, and owing to that unfortunate circumstance was prevented sharing the glories of the action with the Dutch fleet, under Admiral De Winter, off Camperdown, the 11th of October, 1797. Capt. Hope's next commission was to the *Kent*, 74, in February 1798, a new ship, and fitting for the flag of Lord Duncan. In this ship, he assisted in the combined expedition against Holland, by this country and Russia, and was present at the capture of the Helder, and the surrender of the Dutch squadron under the orders of Rear-Admiral Storey. With this important intelligence, Capt. Hope arrived in London, for which he received the usual gratuity of 500*l.*; and was soon after presented by the Emperor of Russia with the riband and cross of the Knight of Malta.

Admiral Lord Duncan having resigned the command of the North Sea squadron, the *Kent* was sent to the Mediterranean in June 1800, to join the fleet under the orders of Admiral Lord Keith. In the same year, an attack was meditated upon Cadiz, and Capt. Hope was nominated to command a detachment of seamen to be so employed. A violent epidemic disease was, however, found to be raging in the place, and the enterprise was therefore abandoned, and the ships to have been employed returned to Gibraltar.

The expedition against the French, under Buonaparte in Egypt, having been determined upon, Lieut.-Gen. Sir Ralph Abercrombie, with his staff, embarked on board the *Kent*, at Gibraltar, and Capt. Hope had the honour of conveying the gallant hero to that country where his military career so nobly terminated. Capt. Hope remained on the Egyptian coast until the surrender of Cairo, when the service requiring that the *Kent* should be an Admiral's ship, Sir Richard Bickerton hoisted his flag accordingly, and Capt. Hope returned home, after the former had offered him the situation of Captain of the Fleet; and for his services on the coast of Egypt, he received by command of the Sultan, the Turkish order of the Crescent.

Capt. Hope remained unemployed until early in 1804, when he was appointed to the *Atlas* at Chatham, but was soon after, through ill health, compelled to relinquish the command, and which was the last he held as Captain.

In 1807, when Lord Mulgrave became First Lord of the Admiralty,

Capt. Hope, (who had previously assumed the name of Johnstone, in addition to that of Hope,) was appointed one of the commissioners of that Board, where he remained until 1809, when he resigned, and was succeeded by Capt. Robert Moorsom, then private secretary to Lord Mulgrave.

Capt. Hope was on the 1st of August 1811, appointed one of the Colonels of the Royal Marines; and on the 12th of August, the following year, promoted to the rank of Rear-Admiral of the Blue. In November 1813, he was appointed Commander-in-chief at Leith, and on the extension of the Order of the Bath to three classes in 1815, was nominated a Knight Commander. Rear-Admiral Sir W. J. Hope was a second time appointed to the command at Leith in 1816, and hoisted his flag accordingly.

August 12th, 1819, he was promoted to the rank of Vice-Admiral; and in January 1820, on the appointment of Sir Graham Moore to the Mediterranean command, he again became a Lord of the Admiralty; and when his present Majesty, then Duke of Clarence, was appointed Lord High Admiral, was named one of the Council to His Royal Highness.

In March 1828, Sir William J. Hope was appointed by the Lord High Admiral, on the death of Sir Thomas B. Thompson, Treasurer of the Royal Hospital, Greenwich, and resigned his seat at the Admiralty. Great frauds and neglect being discovered and committed by individuals employed in the office belonging to the Treasurer of the Hospital, an Act of Parliament was obtained for the better regulation of that noble establishment, and the whole placed under the direction of the Board of Admiralty. In consequence of this alteration, the office of Treasurer was abolished, and Sir William Johnstone Hope was appointed one of the five Commissioners for managing the affairs of that excellent institution.

On the death of Admiral Lord Radstock in 1825, Sir William Johnstone Hope, was, 4th of October of that year, created a Grand Cross of the Bath, and about five months since, by the command of his present Majesty, was sworn in one of the members of the Privy Council.

In 1800, while upon service, Capt. Hope was elected Member of Parliament for the Dumfries district of Burghs; and in 1804 Member for the County on the death of Gen. Sir Robert Lanrie, and which place he continued to represent until 1830, when, at the general election, he declined the honour of again doing so, and was succeeded by his eldest son John James Hope Johnstone, Esq.

Sir William Johnstone Hope married July the 8th, 1792, Lady Anne Johnstone Hope, the eldest daughter of James, third Earl of Hopetoun, who died at Raehill, near Moffatt, August 1818, and had issue four sons and two daughters, one of whom is maid of honour to her present Majesty. The eldest son is claimant for the disputed title of Marquis of Annandale, through his mother, and who with his brothers and sisters, place the name of Johnstone *after* that of Hope, while Sir William prefixed it *before* that of Hope the same as his wife. The three youngest sons of this marriage are all captains in the navy, one, William James Hope Johnstone, is now captain of the *Britannia*, the flag-ship of Sir Pulteney Malcolm in the Mediterranean, and the others both on half-pay.

Sir William Johnstone Hope, married secondly, October the 30th, 1821, Maria, daughter of Sir John Eden, and widow of Frederick William, seventh Earl of Athlone, who survives him.

Sir William Johnstone Hope had been for some months in a declining state of health, and upon the recommendation of the faculty proceeded to Bath for his recovery, at which place he died May the 2nd, 1831, sincerely regretted by all who knew his worth: his remains were interred on the 21st of May, in the family vault in Johnstone Church; Dumfries.

THE SERVICES OF THE LATE REAR-ADMIRAL
GEORGE SAYER, C.B.

REAR-ADMIRAL SAYER was a native of Deal, where he was born in 1773. At an early age he commenced his career as a midshipman on board the Phoenix frigate, Capt. G. A. Byron, in which he proceeded to the East Indies with the ships under the orders of Commodore the Hon. William Cornwallis, and was employed with a detachment of seamen and marines at the reduction of Tippoo Saib's forts, &c. on the coast of Malabar. Mr. Sayer returned home in the Phoenix in July 1793, and was promoted to the rank of Lieutenant, into the Carysfort, Capt. (now Admiral Sir Francis) Laforey, and was present at the capture of the Castor, on the 29th May 1794, formerly an English frigate, but which had been taken by a division of the French fleet on the 10th of the same month, while convoying a fleet of merchant ships to Newfoundland; the Castor being then commanded by Capt. Thomas Troubridge.

The action between the Carysfort and the Castor continued one hour and fifteen minutes, and many were killed and wounded on both sides. The latter ship was commanded by M. L'Huillier.

Lieut. Sayer subsequently served as first lieutenant, with Capt. Laforey, in the Beaulieu frigate, and the Ganges, 74, until his promotion from the latter to the rank of master and commander, in March 1796, by Admiral Sir John Laforey, and to command the Lacedæmonian sloop-of-war on the Leeward island station; and was present at the capture of St. Lucia. He then was appointed to the Albacore sloop, where he remained but a short time. His next command was to the Xenophon, on the North Sea station, and in 1799 he brought from Hamburgh to England in that vessel, Napper Tandy, the Irish rebel, and his companions, as state prisoners. Capt. Sayer was afterwards appointed to the Inspector, of 16 guns, from which he was removed, upon being promoted to the rank of post-captain, February 14th, 1801. Capt. Sayer remained upon half-pay until 1804, when he was appointed to the Proselyte of 28 guns, and sailed in the following year with a convoy under his orders to the West Indies, safely eluding a French squadron of five sail of the line and some frigates, which had sailed from Rochfort, to intercept him.

In July 1805, Capt. Sayer was appointed to command the Galatea frigate, and was present at the surrender of the Danish Islands of St. Thomas, St. John, and St. Croix, and several merchant vessels, in

December 1807; and the boats of the Galatea boarded and captured the French corvette *le Lynx*, of 18 guns, off the Coast of Caraccas, after having been twice repulsed in their attempt. The Galatea returned home in 1809, and upon examination was found so defective, and in want of such extensive repairs, as to cause her being put out of commission; and in November following, Capt. Sayer was appointed to the *Leda*, a new frigate of 42 guns. In the following year, the *Leda* conveyed some transports, with troops on board, to Cadiz, and returned from thence with Vice-Admiral Purvis, who had been relieved in the command by Admiral Sir Charles Cotton. The *Leda* subsequently convoyed a fleet of Indiamen to Bengal, and joined Vice-Admiral W. O'Brien Drury, at Madras, in January 1811; from whence he was sent with some ships, having troops on board, to pave the way for the reduction of Java; and the services rendered by Capt. Sayer at this place were of the utmost benefit. After its surrender, Capt. Sayer remained as senior officer of the ships employed there, and in June 1812 the Government of India forwarded to him their "particular acknowledgments" of the very high sense entertained of his services since the capture of the island.

Rear-Admiral Sir Samuel Hood having arrived in India, in January 1813, dispatched Capt. Sayer on an expedition to Borneo, and, in conjunction with some troops under the orders of Colonel James Watson, succeeded in subduing the whole province of Sambas. Sir Samuel Hood dying at Madras, December 24th, 1814, after a short illness, the command of the ships devolved on Capt. Sayer, and he hoisted his broad pendant as such on board the *Leda*. On the death of Sir Samuel Hood being known in England, Rear-Admiral Sir George Burlton was appointed to the command, and he arrived at Madras in June following, and dispatched the *Leda* to the straits of Sunda, and the China sea. On Capt. Sayer's return from the latter, he experienced a very severe Ty-foong, in which the *Leda* received great damage and was nearly lost, by which event he did not enter the Straits of Malacca until the 19th of November 1815, when he received the intelligence of the death of Sir George Burlton at Madras 21st of September, when he again hoisted a broad pendant, and became a *second* time commodore on that station.

In November 1816, Rear-Admiral Sir Richard King arrived at Madras as Commander-in-Chief, and Capt. Sayer relinquished the command and returned home in the *Leda*. For his services in India, Capt. Sayer was honoured with a gold medal, and was nominated a Companion of the Bath in 1815. At the promotion of flag-officers which took place 22nd of July 1830, on his present Majesty's accession to the throne, Capt. Sayer was promoted to the rank of Rear-Admiral of the Blue.

The extensive and arduous services Admiral Sayer had been employed on in the East and West Indies had made great inroads upon his health, and after an illness of a few weeks, he died in Craven-street, Strand, 29th of April 1831, aged 58 years. He was unmarried, and has left two brothers to lament his loss, as also an extensive circle of friends, to whom he had endeared himself by his amiable disposition.

LITHUANIA.

FORMING THE CENTRE OF THE REVOLUTIONARY DISTRICTS.

SAMOGITIA, called by the natives Szamais, and in the Polish language Smuids, is a duchy which has long formed part of Lithuania. It has been governed in common with that Grand Duchy, and has from time to time had its own Dukes. The country, although covered with forests, is remarkable for the fertility of its soil; is rich in corn, flax, hemp, and honey; affords game in abundance, and is noted for its fine breed of horses. Samogitia, which at present belongs to the Russian Government of Wilna, abounds in lakes and marshes, that render the communications extremely difficult. To the south is the Niemen, which separates it from Prussia, and into which fall the Willia, the Neweja, the Dubira, and the Joura. The northern part of the country is watered by the Moucha and the Weta, or Windau, the first of which, under the name of Aa, falls into the Dwina near Riga; whilst the latter runs into the sea, a little below Windau.

Samogitia is inhabited by two distinct races of men; the first of lofty stature, and descended from the Weudes, who in remote ages occupied the country; the latter, diminutive, but hardy and robust, like the Lettonians. The fertility of the soil might suffice to render the inhabitants rich, but for their inactivity, and their slavish subjection to ancient prejudices; many of the farmers, for instance, obstinately make use of a plough entirely composed of wood, under the idea that one furnished with the smallest particle of iron is unlucky; consequently it often happens, that the total failure of their harvest compels them to subsist on radishes and turnips, which in this country grow to an enormous size. Their sowing season seldom commences till about three weeks after Whitsuntide, but the excessive heat of their summers usually ripens the grain in six or seven weeks.

In point of civilization, the inhabitants of Samogitia, are, perhaps, less advanced than any other people of Europe. Though converted to Christianity in 1413, they still retain many of their ancient Pagan superstitions, believing implicitly in sorcerers, demons, and spirits. The village curates are their oracles, and possess incalculable influence over the lower classes of the populace.

When Samogitia was under the dominion of the Poles, the capital of the country was the little town of Rosienne, at present the capital of a district situate on the Dobisza, forty-three leagues north-west of Wilna. This town, which is now the residence of the Catholic bishops of Samogitia, is built of wood, and contains two churches and a college of Piarists. Keidamy, in the district of Rosienne, belongs to the Radziwill family, and is the capital of their immense possessions in Lithuania. It contains a Carmelite monastery, two Protestant churches, a Russian church, and a gymnasium.

Telch or Telcha, and Chawle, formerly two inconsiderable towns, are at present raised to the importance of capitals of districts. The latter was once a commandery of the knights of the Teutonic order, and was afterwards governed by the Grand Dukes of Lithuania. But Jourberg, or Georgenbourg, in the Polish dialect Jurbok, must now be considered the most important town of Samogitia. It is a bustling commercial town belonging to the district of Rosienne, and built on the Niemen; it possesses a good harbour, and a custom-house established by the Russians. The remainder of the Russian Government of Wilna is situate to the east and the south of Samogitia, extending to the south as far as the Niemen and the Meranganka. The soil, though marshy, is in general fertile, and is well adapted for the breeding of cattle, particularly sheep. The inhabitants devote themselves with much success to agriculture, and to the rearing of bees. Their commerce is carried on with Prussia, Riga, and Libau. The population of the place is composed of Lithuanians, (who form the majority,) of Russians, Poles, and Jews; also of 1300 Tartars who have forgotten their native dialect. The number of the inhabitants of the government of Wilna, Samogitia included, may be estimated at one million of souls.

Wilna, the capital, is built upon a number of little eminences at the con-

fluence of the Wilia and the Wilka. Its foundation is ascribed to Gedimin, Grand-Duke of Lithuania in 1305. Previously to its union with Russia, it was the capital of the Grand-Duchy, and gave name to a Palatinate. The ancient ducal chateau, which is now in a ruinous state, is remarkable for its arsenal, the hall of its former tribunal; and opposite, the handsome church built in 1386. In the latter, treasure to a large amount is deposited: it also contains the marble chapel of St. Casimir, whose shrine of solid silver is said to weigh upwards of 3300 pounds. In the town, which is extensive, and to which have been added two suburbs named Autokolla and Roudaiaszka, there are several convents, and more than forty buildings devoted to public worship, including a Lutheran, a Reformed, and a Greek church; a Tartar mosque, and a Jewish synagogue. The remaining churches are Polish. Wilna also contains some handsome squares, adorned with houses built of stone.

The Catholic bishoprick of Wilna was founded in 1387. The university founded by Bishop Valerien Szuskowski in 1570, and confirmed by King Stephen, holds its sittings in the ancient college of Jesuits. The Emperor Alexander conferred a new organization on this establishment, of which Prince Adam Czartoryski, now President of the National Government of Warsaw, was for many years the principal Director. Wilna also possesses a college of Piarists, a Greek school for speculative theology, a Catholic seminary, a gymnasium, and five printing establishments. It is celebrated as birth-place of the Polish bard Casimir Sarbiewski, whose poetry Hugo Grotius compared to that of Horace. The population of the town is estimated at 25,000 inhabitants; the number of houses at upwards of 3000.

Troki, founded in 1321 by Gedimin, is another town belonging to the government of Wilna, and situate five leagues to the west, on a lake named Bressale, which communicates by means of a canal with the Wilia. In 1390, it was consumed by fire, and having been rebuilt, was in 1655 destroyed by the Russians. It was formerly the residence of the Grand-Dukes of Lithuania, who subsequently removed their seat to Wilna. It is sometimes, for the sake of distinction, called New Troki, as at the distance of a short league is a village named Old Troki, in which may be seen a Benedictine abbey. In Troki there are two chateaux, one of which is built on an island of the lake Bressale. The town, all the houses of which are built of wood, is of considerable size, and has three parishes; in the largest is a miraculous image of the Virgin, to which a number of Pilgrims from all parts are accustomed to pay their devotions. In the district to which the town belongs, is a large glass manufactory, which supplies a considerable portion of Lithuania with bottles.

Amongst the rivers of European Russia, one of the most useful is the Niemen, called in German, the Memel. This river, the greater part of whose course is through Lithuania, takes its rise south of the Russian government of Minsk, whence it enters the districts of Wilna and Grodus, and afterwards, passing the Russian frontier, enters Prussia, and flows through several channels into the gulph of the Baltic called Curisch-Haff. It greatly facilitates the trade of Lithuania, and even of a part of Volhynia. By means of the canal of Oginsky, a communication is established between the Ukraine, Little Russia, the Black Sea, and the Baltic. This canal established between the rivers Chara and Yatsolda, for the purpose of uniting the Dniپر and the Niemen, was commenced by Count Oginsky, Marshal of Lithuania, and called after his name: the undertaking was afterwards interrupted, but was resumed under the Russian Government in 1798, and terminated in 1812. The utility of this channel of communication will be still further increased on the termination of another, which has recently been projected, and by which it has been proposed to unite the Niemen with the Dwina. More than six hundred barges annually descend the Niemen with the productions of Lithuania and Poland, and return laden with foreign merchandize. The navigation, however, is at times rendered dangerous by shoals, of which, during the reign of the last King of Poland, a fruitless attempt was made to clear the current of the river. Should a more favourable destiny await the hitherto ill-fated Poles, the undertaking, recommenced under happier auspices, may, it is hoped, be crowned with success.

FORMATION OF A NAVAL AND MILITARY MUSEUM.

WHILST other professions have establishments in which their members may prosecute the studies which their particular objects require, and find facilities for the acquisition of general knowledge and useful information, according to the actual state and progress of science, the improvements of art, and the changes or modifications which are continually taking place in the practice of all professions, the NAVAL AND MILITARY SERVICES, though affording peculiar facilities for the formation of such an establishment, and greatly susceptible of being benefited by it, have provided no institution in which their members, when not actively employed, may improve, through their own exertions, the special, elementary education which they may have originally received,

For want of such an Institution, the Officers of the Army and Navy have, in general, neglected to avail themselves of the opportunities which their services in every quarter of the world afford, for collecting and recording much valuable information; whilst others who, with great ability, skill, and industry, have improved those opportunities, find no means of rendering their researches, their collections, and their studies accessible to the Services at large, and consequently useful, in the most appropriate manner, to the nation.

To remedy this, it is proposed to establish, in London, a NAVAL AND MILITARY MUSEUM, for the use and benefit of the United Service, to contain Models, Plans, and Memoirs connected with the Naval and Military Services, interesting Trophies, the Arms and Armour of all ages and countries, specimens of Natural History from all quarters of the Globe, and whatever else may be instructive and curious, or in any way contribute to the improvement of the mind, furnish it with matter for rational pursuit in retirement, or augment professional resources when actively employed.

It is also intended to collect a LIBRARY of History, Science, Tactics, and especially of books of professional reference.* To this important branch of the Institution, there is no doubt that large donations will be made by the members, and that all works connected with Naval or Military matters will be cheerfully presented by their authors.

It will be a subject for future consideration, whether Officers may not be invited to give LECTURES on specific points of Naval and Military science, whereby much practical knowledge may be most beneficially preserved and communicated, and from which an identity of general views and principles may be happily diffused through both branches of His Majesty's Service.

The great aim of this Institution will be, to foster the desire of useful information, and to facilitate its acquisition; it is therefore proposed to admit Officers of all ranks belonging to the Army, Navy, and Marines, the Militia, regular and local, and Yeomanry, the East India Company's Land and Sea Forces, and the Civil Functionaries attached to these departments.

Since such an Institution was first suggested, its completion has been warmly urged by intelligent members of every department of the United Service, whilst the means of carrying it into effect with the best prospect of fulfilling its objects, have been unceasingly kept in view.

This important undertaking has received the gracious sanction of the King, who has condescended to become its PATRON. His Grace the Duke of Wellington has accepted the office of VICE-PATRON, and the Institution already enrolls amongst its Presidents and Vice-Presidents many of the most distinguished names in both arms of the United Service.

* Messrs. Colburn and Bentley have already offered copies of the Naval and Military Works of which they are the Publishers, to the intended Library.

PATRON.
THE KING.

VICE-PATRON.
THE DUKE OF WELLINGTON.

PRESIDENTS.

Right Hon. Sir James Graham, Bart. First Lord of the Admiralty.	General Lord Hill, G.C.B. and G.C.H. Commander of the Forces.
Admiral Sir J. Saumarez, Bart. G.C.B. Vice Admiral of Great Britain.	Lieut.-Gen. Sir J. Kempt, G.C.B. and G.C.H. Master General of the Ordnance.
Admiral Sir Sidney Smith, K.C.B. Ge- neral of Marines .	Marquis of Anglesey, K. G. K. S. P. G.C.B. and G.C.H.

VICE-PRESIDENTS.

Admiral Hon. Sir R. Stopford, K.C.B.	Gen. the Earl of Rosslyn, G.C.B.
Vice-Admiral Sir Thomas Byam Mar- tin, G.C.B.	Gen. Lord W. Bentinck, G.C.B. and G.C.H.
Vice-Admiral Right Hon. Sir George Cockburn, G.C.B.	Gen. Hon. Sir Edward Paget, G.C.B.
Vice Admiral Sir Henry W. Bayntun, K.C.B.	Gen. Lord Viscount Combermere, G.C.B. and G.C.H.
Vice-Admiral Sir Edward Griffith Col- poys, K.C.B.	Gen. Lord Viscount Beresford, G.C.B. and G.C.H.
Vice-Admiral Hon. Charles Elphinstone Fleming.	Gen. Hon. Sir A. Hope, G.C.B. M.P.
Vice-Admiral the Hon. Sir Henry Ho- tham, K.C.B.	Lieut.-Gen. Sir Rufane Shaw Donkin, K.C.B. and G.C.H.
Vice-Admiral Sir E. Codrington, G.C.B.	Lieut.-Gen. Sir George Murray, G.C.B. and G.C.H. M.P.
Vice-Admiral Sir Henry Blackwood, Bart. K.C.B.	Lieut.-Gen. Sir Herbert Taylor, G.C.H.
Rear-Admiral Sir Thomas Masterman Hardy, Bart. K.C.B.	Major-Gen. Sir Henry Hardinge, K.C.B. M.P.

At a meeting of the Provisional Committee, held on the 21st of May, Major-Gen. Sir Howard Douglas, Bart. in the chair, It was resolved, that a General Meeting of those eligible to become members, at which it is expected that an Officer of the highest rank will preside, do take place at the Thatched-House Tavern, St. James's Street, London, at two o'clock p.m. on the 25th of June, to adopt resolutions for the definitive establishment of the Institution, and to take into consideration the best mode of providing a BUILDING for the reception of several extensive collections which have been already presented; those by Capt. W. H. Smyth, and Commander Downes, and, through Colonel Freeth, that from the late Royal Staff Corps, containing upwards of one thousand specimens in various branches of natural history, are here particularly referred to.

Under such auspices, and with such favourable prospects, the Provisional Committee fully rely that this call on the United Service will be anxiously responded to by each department, and by every individual officer.

In considering the amount of subscription to this highly important object, the Provisional Committee propose that it should be at the lowest possible rate, so that the smallness of the amount might render it a matter of trifling import to the very junior officers of the Service, while the number of Subscribers should produce a revenue equal to the wants of the establishment; they therefore recommend that it shall be fixed at ten shillings annually for each member, or six sovereigns as a life subscription.

It becomes highly desirable that in the interval before the General Meeting on Saturday the 25th of June, all officers, at least all such as may be within the United Kingdom, should communicate to either of the Secretaries, Commander Henry Downes, R. N. and Lieut. Hall, H. P. Royal Irish, 4, Carlton Chambers, Regent-street, their intention of forwarding this design, and give general directions to their agents in London for the payment of the annual subscription, to Charles Downes, Esq. No. 8, Carlton Chambers, Regent-street, the Provisional Treasurer. Other facilities will hereafter be proposed to render communications more complete.

**ON THE DISTRIBUTION AND DUTIES OF THE UNATTACHED
MEDICAL STAFF OF THE ARMY AT HOME.**

BY A MEDICAL OFFICER.

The following TABLE presents an exact view of the Distribution of the unattached Medical Officers of the Army employed at present at Home, whilst in the OBSERVATIONS which succeed, the Duties these officers have to perform at their respective stations are indicated and occasionally commented upon.

In the column of stations in the Table will be found the name of every place in these kingdoms at which a Military Medical Officer is placed, and in the succeeding columns the title of every Rank now recognized in the Medical Department of the Army.*

The reader may thus embrace at one view the whole of our domestic establishments as above referred to, and compare together without trouble the staff at different stations both with respect to rank and numbers.

As the Officers are thus arranged in a double order, by rank and station, so are the Observations also; one following another in such a manner that easy reference may be made from the table to the observations, or the reverse.

With these explanatory remarks no difficulty can be found in tracing the connection which exists between the different parts of this communication, and therefore we shall add nothing further in the way of introduction.

TABLE OF DISTRIBUTION, † MADE UP TO APRIL 1831.

STATIONS.	Inspector	Deputy Inspector	Assist. Inspector.	Staff Surgeon.	Assist. Staff Surg.	Purveyor.	Deputy Purveyor.	Apothecary.	Totals.
	General.	General.							
Great Britain.									
London	2	—	1	1	1	—	—	1	6
Chatham	—	—	1	2	10	—	1	1	15
Bristol	—	—	—	1	—	—	—	—	1
Coventry	—	—	—	1	—	—	—	—	1
Edinburgh	—	—	—	1	—	—	—	—	1
Glasgow	—	—	—	1	—	—	—	—	1
Leeds	—	—	—	1	—	—	—	—	1
Liverpool	—	—	—	1	—	—	—	—	1
Maldstone	—	—	—	—	1	—	—	—	1
Portsmouth	—	—	—	1	—	—	—	—	1
Sandhurst	—	—	—	1	1	—	—	—	2
Ireland.									
Dublin	3	1	—	1	1	—	1	1	8
Cork	—	1	—	1	4	—	1	1	8
Newry	—	—	—	1	—	—	—	—	1
Total	5	2	2	14	18	—	3	4	48

* Amongst these the titles of *Director General*, *Principal Inspector General*, *Physician General*, and *Surgeon General* will not be met with, as belonging rather to individuals (under special appointments) than to the Department. The individuals at present distinguished by those titles are however included under the class of Inspector General, the highest Rank admitted by His Majesty's Warrant of the 29th July 1830.

† This Table has cost us some trouble, the information contained in the Army Lists with respect to the Medical Department being so arranged, as to render it rather difficult to ascertain the exact number employed, &c. We shall point out hereafter a mode of correcting this deficiency.

OBSERVATIONS.

LONDON—HEAD-QUARTERS.

Inspector General.—This being the highest rank now recognized in the Medical Department of the army, we have included under it, as already intimated, the Director-General Sir James M'Grigor, and the Principal Inspector-General Sir William Franklin, who hold their respective offices by special appointment.

With respect to the duties of these officers it will be sufficient to observe that they embrace every thing connected with the superintendance and patronage of the Department,* and that in the discharge of these duties the parties sometimes appear to act independently of each other, and sometimes in conjunction as a Board. Whether acting separately or in conjunction however, every thing seems in reality to be regulated by the Director-General, as indeed it ought to be; nor have we ever been able to discover that the Principal-Inspector has any duties to perform, which an officer of inferior rank might not discharge with equal propriety and advantage. We might perhaps go farther and say, with greater propriety to himself, and greater advantage to the service; for the Principal-Inspector-General approaches so nearly in rank to the Director-General that he can scarcely be called upon to discharge any subordinate duties, and must therefore be in a great measure unemployed, or voluntarily engaged in a manner not quite befitting his rank and station.

For these reasons it has sometimes occurred to us that it might perhaps be worth while on the part of those in authority to inquire, whether the business of the office in Berkeley Street might not be conducted in a more efficient manner if the services of a Staff-Surgeon were substituted for those of a Principal-Inspector-General there. A more due degree of subordination would thus be obtained amongst the members of the Board, to each of whom distinct and peculiar duties might be allotted, whilst the whole responsibility of regulating and conducting the business of the office would be thrown as it ought to be on the Head of the Department. Nor should it be forgotten in these times of economy and retrenchment that a considerable pecuniary saving might thus be effected for the public, an object always desirable when as in the present instance it can be attained without injury to the service. Thus the highest pay a Staff-Surgeon can claim will not with his allowances amount to more than about 500*l.* per annum, whilst a Principal-Inspector-General receives by special appointment an annual salary of 1200*l.* And if at some future period an officer with the rank and pay of Inspector-General be placed at the head of the Medical Department of the Army, a still greater saving may thus be effected for the public, without impairing in any degree the efficiency or the respectability of the office.†

* *Superintendance and Patronage.*—Between these two classes of duties no necessary connexion exists, except in the very highest department of the service. Any such connexion therefore in any other quarter must be defended if questioned on the grounds of expediency alone. Now we much doubt whether in the Medical Department such a defence could be successfully maintained under existing circumstances.

† The present Board (Medical Officers) costs the country about 3800*l.* per Ann. thus,—

Director-General, salary,	£2000.
Principal-Inspector, do,	1200.
Assistant-Inspector, pay, &c. say,	600.

A Board constituted as here proposed would not cost at the utmost more than £2100 per Ann. thus,—

Inspector-General, pay, &c. say,	£1200.
Assistant-Inspector, do,	600.
Staff-Surgeon, do,	500.

Before quitting this topic we cannot help adverting to another medical appointment, which though not strictly within our present limits is yet too closely connected with the object we have in view to escape notice altogether; we mean that of Director-General of the Ordnance Medical Department. It cannot however be necessary for us to enter into any details upon this subject here, it having been already announced in the most public and authentic manner that the whole department, as a distinct establishment, is to be broken up and its members incorporated with the general Medical-Staff of the Army, *on the first convenient opportunity.** Opportunities of this kind however seldom come unsought for, and are never long absent when anxiously desired.

Assistant-Inspector, 1.—This officer is called Professional-Assistant to the Board, of which he thus in a manner constitutes a part; of his duties it is not necessary to say anything further at present.

Staff-Surgeon, 1; Assistant-Surgeon, 1.—These officers constitute properly speaking the London Medical-Staff, for all the others located there belong to the army in general, rather than to the particular district in which they are placed. As London is a great Recruiting station, the seat of a General Hospital,† and the resort of sick officers and soldiers from all parts of the world, it may be easily imagined that the services of these two officers cannot well be dispensed with. We are indeed strongly inclined to believe the number ought rather to be augmented, and that a second Assistant-Surgeon might with great propriety and advantage be added to the Staff of London.

Purveyor.—There is no officer of this rank now employed in Great Britain, nor indeed on any station either at home or abroad. Nor is there in London even a Deputy-Purveyor, although we have here a small General Hospital already referred to, and although an officer of that rank is supposed to be necessary at Chatham, and at Dublin, and at Cork. The truth is, Purveyors and Deputy-Purveyors are not Medical Officers, and never should have been so classed; but are to all intents and purposes Commissaries, as every one acquainted with their respective duties must be perfectly aware.‡ With the Commissaries therefore they should be incorporated, and an officer from that Department of suitable rank might then be attached to each General Hospital or medical station where such aid was deemed necessary.

Apothecary, 1.§—This officer belongs, properly speaking, to the Medical Board, and should be so considered and enumerated, his duty being to retain in charge and issue under orders from the Director-General, the medicines and medical stores collected in London for the use of the army at large.

As the rank and title of *Apothecary* was abolished in the army by the Warrant of the 29th of July last, it is time we should think to discard the term altogether, and introduce that by which those officers are hereafter to be distinguished. Let them then at once be assimilated and identified with the Surgeons or Assistant-Surgeons of the army according to their claims and services, for to one or other of these two classes must the duties hitherto discharged by the Apothecary be ultimately transferred.

* *Vide* Speech of Sir H. Hardinge, then Secretary-at-War, in debate on Ordnance Estimates, Feb. 1829. The whole of the Ordnance Medical-Staff on full-pay at present amount only to thirty-eight, and of these, if incorporated, some probably might be spared.

† The York Hospital at Chelsea.

‡ The Purveyor has charge of and is responsible for the care, management and issue of all provisions and stores, medicines excepted, belonging to the Hospital; and for the due supply of the same by contract, purchase, or requisition.—Instructions for General Hospitals, p. 79.—Horse-Guards, June 1824.

§ *Apothecary.*—This being the title of a class and still continued in the Army Lists, we have been obliged to admit it into the Table, though it must now be considered as obsolete, and deservedly so.

CHATHAM.

Assistant-Inspector, 1.—Chatham may with great propriety be considered as the Head-Quarters of the Medical-Staff of England, the number of officers there being always greater than at any other station, and the establishment itself more complete and more extensive than any other of the kind in these kingdoms.* Under these circumstances one would expect to find at the head of this establishment an officer of higher rank than an Assistant-Inspector. And no doubt such would have been the case if the appointment and distribution of Medical Staff-Officers were regulated in our service by any fixed or general principles. For Dublin and Cork has each at this moment a Deputy-Inspector-General, to execute or to superintend the execution of duties much less onerous and much less important, than those confided at Chatham to an Assistant-Inspector. But sometimes, as it would appear, men are selected for stations, whilst at others stations are selected for men.

Staff Surgeons, 2.—One of these officers has generally charge of the Lunatic Asylum, the other of the surgical cases in the General Hospital. Two are necessary and perhaps sufficient for the duties of the place, but the number ought not to be too strictly limited, as one or two supernumeraries of this rank might occasionally be employed at Chatham with much advantage to themselves and to the service.

Assistant Surgeons, 10.—One half at least of these gentlemen may be considered as supernumeraries,† that is, persons whose presence is not absolutely necessary here for the purposes of duty, but who are retained at the place either as a reserve to meet contingencies or for the purposes of instructions, &c. It would indeed be very desirable that every Medical Officer on his first appointment to the service should be permitted or rather obliged to pass a few months at Chatham, for the purpose of receiving instruction and acquiring information with respect to those duties of which, as peculiar to the army, no knowledge can be obtained in the schools and colleges of civil life. We may even add that this object is one of the most important which an establishment like that at Chatham might be rendered subservient to, and that too without interfering in any manner with the treatment of the sick, or throwing upon the public any additional expense whatsoever. Nor should this routine of duty be confined to officers on their first appointment, for all Medical Officers should at one time or other be permitted to make themselves acquainted, as favourable opportunities offer, with the mode of conducting the business of a General Hospital, which differs in so many respects from that which necessity compels us to observe in Regiment Establishments.

Apothecary—Deputy Purveyor.—We have nothing to add to the observations already made with respect to those officers under the head of London.

BRISTOL, COVENTRY, EDINBURGH, GLASGOW, LEEDS, AND LIVERPOOL.

These are all Recruiting depôts, to each of which under the present system a Staff Surgeon is necessarily attached, for the purposes of inspection and attendance on the recruits and parties, &c.‡

Of these stations it is not now necessary to say any thing particular with the exception of Liverpool, of which we may mention that the duties of the

* In fact the Hospital at Chatham may be considered as the only specimen of a General Hospital in these kingdoms, and as such should be supported, were it only for the purposes alluded to in the text.

† Some officers of this rank must always be retained on full-pay as supernumeraries, were it only to take charge of transports proceeding with troops to foreign stations. But the number should be limited, and the duty at Chatham be taken in rotation through the whole class.

‡ There are four other Recruiting Depôts in these kingdoms besides those above mentioned, with each a Staff-Surgeon attached, viz. Londou, Dublin, Cork and Newry.

Surgeon there are much more heavy than at any of the others; so much so indeed as to render in our opinion the presence of an Assistant Surgeon very desirable. For Liverpool, be it remembered, is not only a Recruiting depôt for the King's army and for the East India Company's service also, but it is moreover the great place of *transit* for recruits and deserters and troops of all kinds to and from Ireland; so that it is never perhaps without some sick soldiers, and these often of the worst and most intractable description.

MAIDSTONE.

This is the Cavalry Depôt, on the staff of which a Veterinary Surgeon is also borne in addition to the Assistant Surgeon noticed in the Table.

PORTSMOUTH.

Whenever troops are about to embark on board of transports or other vessels in any port of the United Kingdom, the General or other officer commanding at such port is directed to cause the senior officer of the Medical Staff at or near the station, to repair on board each vessel, and make a most minute and particular inspection of the same, and report thereon to him previously to the embarkation of the troops. And similar visits, inspections, and reports are directed to be made whenever troops arrive in any port of these kingdoms for the purpose of disembarkation.

General Regulations, &c. 1822, pp. 309.

The preceding paragraph explains sufficiently the nature of the duties which the Staff Surgeon stationed at this place has to perform. After perusing it the professional reader, military or medical, will probably feel inclined to ask, by whom are those duties performed at Plymouth, where troops so frequently embark and disembark, but where, as may be seen by the Table, no Staff Medical Officer of any kind is at present stationed? To make amends for this, however, more than a double portion, both as to rank and numbers, is assigned to Cork, another station of the same kind.*

SANDHURST—ROYAL MILITARY COLLEGE.

The establishment at this station consists of a Surgeon and Assistant-Surgeon; and less we presume would not be sufficient for the duties of the place, as an attempt made in 1829 to do away with the latter appointment, was abandoned as being, no doubt, found inexpedient.

As the Royal Military College is thus supplied with Medical officers from the regular Staff of the Army, we should like to know why the other Military Establishments of the empire are not placed upon the same footing with respect to medical aid. We allude here to Chelsea Hospital, to the Military Asylums at Chelsea and at Southampton, and to the Military School in Dublin; the medical officers of which all seem to hold their respective appointments rather as civilians than as military men†—that is, these appointments seem to be considered by all parties as permanent ones, and the services of the individuals holding them do not seem to be available for any other duties.‡

* We have not thought it necessary to include in the Table the sinecure appointments of Physician and Surgeon to the Garrison of Portsmouth; the former of which, with a salary of 9s. 6d. per day, has been held for the last twenty years, (since June 1811,) by the present Director-General, Sir James M'Grigor.

† These officers are, at Chelsea Hospital, a Physician, Surgeon, and Assistant-Surgeon; at the Military Asylum, Chelsea, a Surgeon and Assistant-Surgeon; at the Military Asylum, Southampton, an Assistant-Surgeon; and at the Military School, Dublin, a Surgeon.

‡ The Medical Officers of our domestic Military Establishments should either be permanently attached to those institutions, in which case they can have no claim to increase of pay or to promotion in the army; or they should be drawn in rotation from the unattached Staff of the army, and appointed to those institutions for

Now if these things be so, the sooner they are corrected the better, for such anomalous distinctions are not only unjust in themselves but decidedly injurious to the public service—and the same may be said with truth of other medical appointments both at home and abroad, which though held by men under commissions purely military, are yet held by them for a long succession of years, to the exclusion of others equally entitled to share in their advantages.

IRELAND—DUBLIN.

Inspectors-General, or Officers of the highest rank, 3.*

Deputy-Inspector-General, 1.—Ireland has been emphatically called the land of jobs, and the Military Medical department, as we shall presently see, furnishes no exception to the general rule. For what but a system of jobbing could maintain in Dublin at this moment a medical establishment consisting of a Director-General, a Physician-General, a Surgeon-General, and a Deputy-Inspector-General; and all these appointments moreover (the *first* always excepted†) held by men whose time is and always has been devoted to private practice, and who have in reality no military duties of any kind to perform. It is true there is a General Hospital in Dublin which these dignitaries occasionally condescend to visit;‡ and now and then perhaps one or other is called upon to go through the ceremony of presiding at a Medical Board on some sick officer or soldier; or invited to meet some Regimental Surgeon of the Garrison in consultation on some doubtful or dangerous case of disease—but beyond this we assert these gentlemen have nothing to do with the Army, and if they had, their time is too much occupied with other matters to admit of their attending to it. Let the whole then be swept away, and let the Medical officers of the Army be no longer insulted by seeing men without claims and without duties exalted over their heads, and endowed with the possession of rank and emoluments, for which those who have grown old in the service might vainly aspire.§

Nor must the hand of reform be checked until all traces of a distinct and independent establishment are entirely done away with; and an efficient, uniform, and responsible system of medical government introduced, instead of the anomalous and unsatisfactory system which now prevails. Instead of a provincial Director-General then with undefined and in some respects unlimited authority, let us have an Inspector-General, or even a Deputy-Inspector-General, drawn from the ranks of the Army, and in all respects subordinate to the head of the Department in London. And instead of the Physician-General, the Surgeon-General, and the Deputy-Inspector-General, who have hitherto done so little for the public and for whom the public has already done so much, let us have one or two Staff Surgeons, to take charge of the Royal Hospital and attend upon the unattached Staff of the Garrison who may require their aid.

Staff-Surgeon, 1.—This officer is attached to the Recruiting Depot at this station, for the purposes already noticed under the head of Bristol.

limited periods, as officers now are, or ought to be, to other stations. Between these two there is no middle course, for no man belonging to one class can have any just claim to participate in advantages peculiar to the other.

* Viz. Director-General, Physician-General, and Surgeon-General.—*Vide* Introductory Remarks, and Observations under the head of London.

† Viz. the Director-General Doctor Renny; who has long been at the head of the Medical Department of Ireland, and whose zeal, ability and integrity as a public officer have never been impeached or suspected.

‡ General Hospital, viz. the Royal Military Hospital in the Phoenix-Park.

§ The Physician-General and Surgeon-General hold their offices by patents, the first of which was issued so early as 1660, and the last so late as 1820!!! The pay of each, originally ten shillings per day, is now about twenty; that is, about what a regimental Surgeon receives after twenty years of actual service.

Assistant-Surgeon, Deputy Purveyor, and Apothecary, 1.—These gentlemen are all employed at the Royal Hospital, where they no doubt enjoy very comfortable berths. It is time however the advantages they enjoy should be extended to others, and that they in turn should be permitted to see a little of the world elsewhere.

With respect to the offices of Purveyor and Apothecary we have nothing to add to the observations already made on these points under the head of London.

CORK.

Deputy-Inspector-General.—We have here another Medical officer, invested with high rank, in the receipt of full-pay, and at the same time quietly and permanently settled in private life as a resident inhabitant. Surely such examples as these should be sufficient to attract the attention of those in authority, and bring forth a peremptory order, for nothing else will do, that no medical appointment on the Staff shall be held by any one individual longer than for a given period, and that all officers on full-pay shall pass in rotation from one station to another, and each in turn be employed *abroad* as well as *at home*.

With respect to the medical duties to be discharged at Cork, we may confidently say there are none which require the presence of a Deputy-Inspector-General—a Staff-Surgeon being employed at Portsmouth for the very same purpose, namely the inspection of Troops and Transports on their arrival and departure, &c. It is true there is a subordinate Staff at Cork which Portsmouth has not, and an officer of superior rank, it may be alleged, is required there in consequence. But we doubt much the necessity of maintaining any such establishment as that here alluded to, and deny altogether that a Deputy-Inspector should be at the head of it, under existing circumstances, if it be maintained.—*Vide Chatham and Portsmouth.*

Staff-Surgeon.—This officer is attached to the Recruiting Depôt at this station, for the purposes already noticed under the head of Bristol.

Assistant-Surgeons, 4; Deputy-Purveyor, 1; Apothecary, 1.—We have already expressed our doubts as to the necessity of retaining all these gentlemen at Cork, there being no General Hospital there, nor any duties that we are aware of for them to discharge, except perhaps when troops are about to embark or sail thence for some foreign station. If this be true, Dublin perhaps would be a better place for the residence of any supernumerary Assistant Surgeons it may be deemed necessary to retain in Ireland, as their leisure hours might there be more usefully employed, and their services rendered more available for general purposes. With respect to the Purveyor and Apothecary we must refer to what has been already said on these points under the head of London; but may add that *two* such officers cannot well under any existing circumstances be deemed necessary at this station.

NEWRY.

This is our last station, a Recruiting Depôt with its Surgeon, and as usual in Ireland with the same Surgeon for a long period of time—Is not this too bad?

We must here bring to a conclusion for the present the observations we have to offer on our Medical Establishments. The subject however is by no means exhausted, nor have we any intention of abandoning it in its present state. On the contrary much still remains to be investigated and made known with respect to the Home Department, whilst the Foreign is as yet altogether untouched. To this last then we shall next direct the reader's attention, as the present communication would be in a manner imperfect if not accompanied, or followed, by a similar view of our foreign Medical Establishments.

London, May 1831.

M. M.

REVIEWS AND CRITICAL NOTICES.

ON A NEW ARMAMENT FOR SHIPS OF WAR—AND RAZEERING

THE science of Naval architecture is a study of paramount importance to the British nation; nor is the most suitable and effective equipment of our ships a question less important than their perfect construction. Upon these grounds, and especially at the present moment, the opinions of scientific men, deduced from experiment and applicable to practice, are entitled to impartial consideration.

Two Pamphlets* on the structure and armament of our ships of war, have been recently put forward by Mr. S. Read, of Chatham Dock-yard, avowedly with the double view of suggesting a more efficient artillery for frigates and ships of the line, and of showing cause against the system of *razeering*; the author proposing to obviate the latter by a modification of the former. This he would effect by diminishing the number of the guns, and increasing their range and weight of metal.

In the course of the American war, the lamentable effects of arming our ships with carronades and guns of small calibre were apparent; the enemy, by the superiority of their sailing, chose their own distance, and kept out of reach of our 32-pounder carronades until they had completely disabled our ships with their long 24-pounders, and then taking a position on the quarter, had an easy conquest; what must have been the mortification of our brave, but unfortunate seamen, to find they had been reduced to a perfect wreck, scarcely returning a shot, while their enemy remained in every respect uninjured? Sir James Yeo, in his letter to the Secretary of the Admiralty, dated 12th Sept. 1813, when on Lake Ontario, states that,

“The enemy’s fleet, consisting of eleven sail, having a partial wind, succeeded in getting within range of their long 24 and 32-pounders, and having obtained the wind of us, I found it impossible to bring them to close action. *We remained in this mortifying situation five hours, having only six guns in the fleet that would reach the enemy. Not a carronade was fired. At sunset, a breeze sprung up from the westward, when I manœuvred to oblige the enemy to meet us on equal terms. This, however, he carefully avoided.*”

In this gallant officer’s dispatch of the 15th of November following, he also mentions in strong terms “the deficiency of long guns in the Lake Erie squadron.”

Tupinier, in his memoir on the French Navy, frequently referred to by the Author, affords a clue to the rage for *razeering*; but his views would appear to have been misinterpreted by our Naval Administration; far from advocating the system, he pointedly condemns it; and after having obtained the “*Guerrière*” as a base for a construction *de novo*, proceeds in the following terms: “Renouncing henceforward the construction of 74-gun ships of the line, the best use to make of those which we possess already, whether afloat or on the stocks, will be to arm such as are in *good condition, &c.*” and then details a new armament for them, recommending “to convert into 36-pounder frigates, like the *Guerrière*, such as stand in need of a thorough repair;” well knowing that the 74-gun ships, with their present armament, would be overmatched by the 84 and 92-gun ships of the present day, and that it would be advisable to let them be worn out in the service; and not

* Memoir on a New Armament for the 42 and 46-gun Frigates. By S. Read, one of the Foremen of Chatham Dock-yard, and formerly of the School of Naval Architecture.

Observations illustrative of a Memoir on a New Armament for the 42 and 46-gun Frigates; also some Remarks on furnishing these, and other Ships, with a proportion of Bomb Cannon, in the shape of 68-pounder Carronades. By S. Read.

after the French system, to repair them as frigates. For Tupinier evidently acknowledges such a make-shift to be much inferior to frigates expressly constructed. In comparing French seventy-fours with English of the same dimensions, we should not lose sight of the inestimable advantage the former possess in having their hulls* 380 tons *lighter*.

Our Author, after detailing a new armament for our seventy-fours, goes on to say,

“But although according to the scale of building now adopted by our rivals, it would be the height of absurdity to *perpetuate* them as a *numerous* class of ships; yet, they may be still *worn* out as *effective* ships of the line. The ships of the British Navy should be remodelled, but not after the designs of foreigners; they should, on the contrary, take the *lead* in construction and equipment by a bold and scientific mode of proceeding founded on facts: never building more than *one* ship from a new design, before it has been ascertained how far the qualities of that ship have been found to *answer* the *written* estimates and expectations of its constructor, who should likewise be required to state his *reasons* for the same.”

The Author here informs us in a note, that he is prepared to put into the field of liberal and open competition a construction draft for a corvette, carrying long 32-pounders.

“The most exact account of such an experiment should be registered; for if we do not know upon what grounds our *future* proceedings ought to be founded, how can we expect to regulate *their* effects any more than the effects of our previous actions? Without *data*, Naval Construction, as well as every other department of science, notwithstanding general principles may be known, must be attended in its operations with an uncertainty as to the results of our proceedings highly to be deprecated. It is not in this way that a *steady*, or indeed, any progress can ever be reasonably expected to take place. It is not in this way that the illustrious Newton and his followers have *gradually* unfolded the mechanical laws of the universe. They have not achieved this splendid victory of mathematical science by the indulgence of baseless imaginations, but by the severe and patient study of *facts*, and by a constant reference to the motions and magnitudes of the heavenly bodies. In like manner, the *true* knowledge of the properties of ships can only be acquired by patiently collecting *facts*; bringing these facts under the dominion of mathematical analysis; and constantly referring the deductions made therefrom to the *actual* performance of these vast machines at sea.”

Whilst we see our great rivals, the French, concentrating the efforts of their naval engineers for the improvement of their marine, (among whom may be mentioned Barons Lainé, Dupin, Rolland, Pestel, Forfait, Tupinier, &c.) we have left ours to the sole direction of one man. With the data, however, furnished by Tupinier, there is less chance of failure, unless he get entangled in some fanciful theory, such as *fish-like* and *duck-like* forms for the bottoms of ships, fancies so fully exposed by Knowles.†

Our author goes on at some length to confute an objection that has been raised against his measure, that by the mixture of metal of the same calibre, but of different denominations, a mistake *might* arise in the cartridges; that one intended for a gun might be put into a carronade and *vice-versa*; but supposing such might be the case, the carronade has been repeatedly tried with a much larger quantity of powder, and is well able to bear the charge. A mixture of carronades and long guns has constantly existed in our service.

The comparative calculations on his proposed armament are shown in the following table.

* Brand's Quarterly Journal of Science, No. 12, last series.

† See that Gentleman's Lectures on Naval Architecture, delivered at the Royal Institution, May 1826, and published in Morgan and Creuze's Naval Papers.

DESCRIPTION OF SHIPS.	42 GUN FRIGATE.		46 GUN FRIGATE.		52 GUN FRIGATE.	36 GUN FRIGATE.
	Present Armament.	Proposed Armament.	Present Armament.	Proposed Armament.	Winchester.	Castor.
No. of Guns { Main Deck . { Qr. & Forecastle	26 long 18-Prs. 14 32-Pr. Car. 2 9-Prs.	{ 16 long 32-Prs. 10 32-Pr. Car. 6 long 32 Prs. 2 — 12 Prs.	28 long 18-Prs. 16 32-Pr. Car. 2 long 9-Prs.	{ 18 long 32-Prs. 12 32-Prs. Car. 6 long 32-Prs. 2 Congreve 24-P.	30 long 24-Prs. 2 Ditto. 20 42-Pr. Car.	22 long 32-Prs. 14 long 18-Prs.
Total .	42	34	46	38	52	36
Force of a Broadside with single-shotted long Guns, distant action	<i>Pounds.</i> 234	<i>Pounds.</i> 364	<i>Pounds.</i> 261	<i>Pounds.</i> 408	<i>Pounds.</i> 384	<i>Pounds.</i> 478
Force of a Broadside, with double-shotted long Guns, and single-shotted carronades, close action	716	888	778	1008	1188	956
Weight on Main Deck with present Armament	<i>Tons.</i> 59 · 28		<i>Tons.</i> 63 · 84			
Weight on Main Deck with proposed Armament	61 · 02		69 · 54			
Weight on Quarter Deck and Forecastle with present Armament	20 · 50		21 · 84			
Weight on Quarter Deck and Forecastle with proposed Armament	21 · 78		23 · 18			
Weight of Shot { Present Armat. { Proposed Do.	41 · 07 37 · 42		46 · 16 42 · 85			

The Memoir proceeds—

“As the expense of *trying* the author's principle must be very inconsiderable, compared with that of cutting down a frigate to a corvette, there can be no possible objection to prove, by an experiment, the truth of a proposition which, upon every rational view, will give *one hundred* 32-pounder frigates to the British navy, perfectly unconquerable by any 32-pounder corvette, at distant fighting; and possessing, in close action, half as much force again in ordnance; besides *having in all circumstances the inestimable advantage of the main-deck guns, amongst which are eight or nine long 32-pounders of a side, being secure from falling masts and yards, &c.* These frigates' hulls cannot have cost the nation less than *two and a half millions of money*, or about 25,000*l.* apiece; and therefore, *supposing* that the expense of cutting down be only 500*l.*, we have to add this to the original cost; hence every corvette obtained in this way will have cost the nation 25,500*l.*, whilst one of the same force might be built from an original construction for about 19,000*l.*, taking the quantity of materials that would be required as a standard of comparison. Thus an expensive corvette has been obtained (putting aside all consideration as to its sailing qualities), and a frigate lost to the navy, although capable of bearing from *twenty-two to twenty-four* long 32-pounder guns, and also from *ten to twelve* carronades of the same calibre.”

Thus, it would appear, we have obtained a corvette at a *waste of 6500*l.** every way inferior to an original construction. We have already diminished our line-of-battle by ten ships of seventy-four guns, and replaced them with ten frigates, incapable of outsailing those of the enemy; and are we as rapidly, and with the same result, to diminish our frigates, by converting them into corvettes?

Force is neutralised without velocity, as humiliating experience proved in the case of the *Majestic*, *razéed* 74, in the chase and capture of the American frigate *President* in 1815.

“No fairer field of trial can be imagined”—says our author, “four British ships in chase of an enemy, whose sailing was such as to render the utmost exertion necessary in each pursuing vessel, the American ship having the start by about five miles. The *Majestic* was at the outset the nearest ship, but was soon distanced, and was obliged to give up the pursuit to the *Endymion*, a *fac simile* of the French *Pomone* 24-pounder frigate. The American frigate, although out of trim at the time, and overloaded with stores, was brought to action by the *Endymion* with difficulty, and would most probably have ultimately escaped, had not the two other frigates of the British squadron come into action at the critical moment. As for the *razée*, not *one shot* from her ever reached the *President*, or had the remotest chance of doing so, throughout the whole affair, which lasted from 5 A.M. to midnight.* Lastly, the velocity of the *razéed* *Barham*, is but very trivial in excess over the same ship in its original state as a seventy-four; and compared with the *Blenheim*, a seventy-four built from the same draft, about *equal* in point of sailing. Now, if the 32-pounder frigate, obtained by *razéeing*, cannot outsail the 24 or 32-pounder frigates of original design,—and in the chase of the American *President*, we have ample proof that it cannot,—to what purpose have we diminished the line-of-battle by a ship of seventy-four guns, and gone to the additional expense of converting it?”

To what purpose indeed! we have obtained an expensive ship, of *less force*, and *not superior in velocity*.

Admiral Duperré after his sojourn in the Chesapeake in 1819, says,—

“The Americans calculate by the adoption of their system of building, on compelling the European navies to do away with their present ships of the line (at least those of seventy-four and eighty-four guns), and to construct new ones. In this case they will have the advantage of priority.”

Similar reflections are also found in Dupin's work on Great Britain.

The French and other nations will not believe that we are perpetuating

* See James' Naval History and Naval Occurrences.

the class of 46-gun frigates in our navy, whilst our enemies are building none but 60-gun frigates; they tell us, we only call them so in our Navy List, as a blind: verily they give us credit for more sagacity than we deserve.

“ That the French will *construct* corvettes carrying such a high calibre as their 30-pounder, is clear from M. Tupinier’s opinions. He does not, in the remotest way, hint at such a step as *cutting* the French 18-pounder frigates even into 24-pounder corvettes, although they are comparatively few; but endeavours to save them to the French marine, by giving them a more powerful armament. The 46 gun frigates of the British navy are built after the lines of these French vessels. Those known as the ‘*Hebé* class’ are constructed by Baron L’Ainé. Those built after the ‘*Presidentie*,’ such as the Seringapatam, Africaine, &c. are due either to M. Rolland, or M. Pestel, two other eminent French constructors. Tupinier pronounces them all to be very fine ships, and well adapted to fill up the interval between his 36-pounder frigate of 184 feet long, and the 24-pounder corvettes of the French navy.”

This being the case, what vessels shall we have in our service able to compete with them? our *raised* corvettes being inferior in velocity, will not be able to overtake them, and if indeed they should, unless the guns be mounted on Marshall’s carriages they will only be able to carry 24-pounders, consequently will be not of sufficient force. Would it not, therefore, be advisable to construct 32-pounder frigates carrying sixty guns, and 32-pounder corvettes carrying twenty-eight or thirty guns? these with the increased armament for the 42 and 46-gun frigates might be sufficient to regain our former superiority.

Our author plausibly exhibits the superiority of his armament by estimating the quantity of shot thrown at a broadside both in *close* and *distant* action; he increases the force of single-shotted guns in *distant action*, the 42-gun frigate 180 pounds, and the 46 by 147 pounds; and in *close action*, with double-shotted guns and single-shotted carronades, the former 172 and the latter 230 pounds; these being all 32-pounders, the devastating effect of the shot is much greater.

“ The diameter of the 32-pounder shot is 6.105 inches, whilst that of the 18-pounder shot is 5.04; hence the size of the hole made by the former will be to that made by the latter as 37.27 : 25.4, or nearly half as large again. It will only be necessary to indicate this circumstance to prove the devastating effects of the broadside of the new armament, to which the present could offer no adequate return; for example, in the 46-gun frigate only fourteen eighteen-pound shot could be opposed to twelve of thirty-two pounds, and one of twenty-four pounds, in distant action: and it is also well known how soon a ship’s masts are cut down by large shot. In close engagement, this disparity would be still more fearfully increased; for whilst the old armament could only bring eight thirty-two pound shot into her broadside, the new would discharge no less than *thirty* shot of the same nature.”

The destructive effect of one large shot compared with a number of smaller ones is amply proved by the experiments of Robins and Hutton; those of the latter are particularly valuable, having had the whole resources of the Ordnance department at his command, and been aided by several of our ablest artillery officers. After having established the fact that the *velocity* of the ball is totally *independent of the weight of the gun*, and that the *range and initial velocity* depend solely on the *length* (the charge of powder and weight of shot being equal in each case); how in the name of common sense could the Board of Ordnance, from the mere whim of a late Surveyor-general, having these facts before their eyes, and after having exploded the 42-pounder guns from the service, as being too heavy and cumbersome; how, we ask, could they have expended a large sum for the purpose of casting 32-pounder guns of the same weight as the late 42-pounders, viz. 65 cwt.? Possessing, moreover, no greater range and velocity than the nine and a half feet 32-pounder of 56 cwt. We have heard, but cannot vouch for the

fact, that after having expended some thousands, the Board have as suddenly relinquished their determination as they had hastily adopted it.

The Author, having supported by *practical data* his propositions for arming the 42 and 46-gun frigates, with long 32-pounders and 32-pounder carronades, proceeds to reform the armaments of our 74 and 84-gun ships, on the same principles; but he has not stopped here, and at a moment when it appears to be resolved to introduce bomb cannon into Naval warfare, by means of steam-vessels, and thereby place in jeopardy even the largest ships of the line, by the employment of such novel means of destruction, he proceeds to show that a simple modification of his principles will invest all our frigates and ships with a formidable number of bomb cannon, in the shape of 68-pounder carronades, which are capable of projecting 8-inch shells. This description of ordnance has been well proved in actual service, whether projecting solid 68-pounder-shot, or 8-inch shells. We are of opinion that any increase of size above the calibre of eight inches, however desirable and *practicable on land* will, *at sea*, be found to be an evil. In this view the Author, it would appear, remarks that the 8-inch shell "is not beyond the *ready* management of one man." A very intelligent and scientific officer of the Marine Artillery, Lieut. Stevens, has also pointed out the necessity of restricting these bomb cannon to the calibre of eight inches. Lieut. Stevens, in his "Remarks on arming Steam and Gun Boats," very judiciously says, "that to use a 12 or 10-inch gun effectively with shot, or to insure the bursting of its projectile as a shell, it must be made to strike the object without previously grazing; to effect this, such ordnance must be elevated from ten to twelve degrees," and consequently "the practice against a ship would be very uncertain."

Now, although the 68-pounder carronade ranges well, yet it cannot pretend to such long horizontal ranges as an 8-inch bomb-cannon; still as it is protected at the longest ranges with such a powerful calibre as the 32-pounder, the armament which Mr. Read has proposed for ships appears, to possess advantages deserving attention. By his plan each broadside, even of the 42-gun frigate, will have four carronades of 8-inch bore, and eleven long 32-pounder guns.

We must, however, refer our readers to the "Memoir" and "Observations" for a variety of facts and considerations, which our limits do not permit us to notice.

We close this article in the emphatic language of the Author.

"Let it be remembered, that the importance of the British Navy, is *infinite* in comparison with the Navies of other Powers: without its Naval preponderance, this vast empire becomes immediately contracted to an isolated spot on the surface of the globe; and sinks, not only into geographical insignificance, but, what is still worse, into political nothingness. If that gigantic arm which embraces both hemispheres, and by which alone the power of Napoleon was foiled, is once paralysed, through a mode of proceeding founded on mistaken views, who will pretend to say, that it can ever, in the present state of the maritime world, be restored to its necessary vigour? Let us beware then, and not be less ready than the French and other nations are to cherish genuine science, and follow its sound dictates; and, above all, let us inquire seriously, whether it be probable that there can be a royal road to the science of Naval Construction, so that those who travel it may, without study or labour, acquire that knowledge, whose attainment, to use the words of Chapman, the celebrated Swedish Naval Architect, 'seems almost to exceed the powers of human understanding.'"

STANDARD NOVELS.—We gave a passing notice in our last Number of the re-appearance of *THE PILOT*, as the precursor of a complete series of the most esteemed Novels in the English Language; and also intimated that this first-born of a very extensive progeny was immediately to be followed by Godwin's *CALEB WILLIAMS*, who has since made his welcome *entrée*. The third number, containing the whole of Cooper's *SPY*, has also appeared, and will be followed by Miss Porter's celebrated Novel, *THADDEUS OF WARSAW*, a work of peculiar interest at the passing period.

We cannot speak in terms of too high praise of this design, nor of the manner in which the spirited publishers are performing their part of it. The high price at which good novels are usually published, exclude them from a permanent place in most private libraries; yet we do not know more delightful companions to have constantly within call, to while away a vacant hour, or relieve the labours of severer study. Here then we have in three volumes the condensed (not abridged) matter of nine, most neatly printed with frontispiece and vignettes, of most convenient size, and also most conveniently cheap. We can add no stronger recommendation of the **STANDARD NOVELS**.

CABINET CYCLOPEDIA. VOLS. 17 and 18.—The Seventeenth Volume of this series consists of a Treatise on Hydrostatics and Pneumatics, by the Editor, Dr. Lardner. It is written with a familiar knowledge of the subject and in a popular style, abounding in practical illustrations of the abstruser operations of these important sciences.

Volume Eighteenth is the second of Sir James Mackintosh's *HISTORY OF ENGLAND*. Taking up the thread of his Narration at the Wars of the rival Roses, the learned Author brings down the History of these Realms to the Reformation and the Accession of Elizabeth. The style of this work is elaborate, but, we think, dry.

The Fourth Volume of *THE CABINET LIBRARY* completes *THE RETROSPECT OF PUBLIC AFFAIRS* for 1831. This useful Summary is composed with clearness, and on the whole with impartiality.

THE TWELVE NIGHTS.—The unpretending Volume bearing the above title consists of a Series of Twelve Tales, written with considerable talent. One—"My First Affair," will be re-

cognized as having already appeared in our pages. The author is evidently a military man, who, from an occasional asperity observable in his language, when speaking of his vocation and its votaries, has not, we fear, been fortunate in his career. There is, however, abundant evidence in these his lucubrations, that there was no lack, at least, of ability, to have commanded success. We shall probably make extracts upon a future occasion, and strongly recommend the *Twelve Nights* to the perusal of those who love a clever and dramatic Tale.

VIEWS IN THE BURMAN EMPIRE. By Capt. Kershaw, 13th Light Infantry.—We feel particular satisfaction in noticing these splendid views, both for their unquestionable merit and as the production of a Cadet and Student of the Royal Military College. Their conception and execution reflect infinite credit upon the source of Capt. Kershaw's instruction, as well as upon his own taste and ability.

Having served in the Burmese war, Capt. Kershaw availed himself of his opportunities to sketch the most striking scenes which presented themselves on the route and during the encampment of the army, attended, where practicable, by the Naval armament. The landscape is strikingly drawn and richly coloured, while figures and objects connected with both services are blended and introduced with the happiest effect. The plates are exquisitely engraved by Daniell, and no labour or expense appears to have been spared in giving to the intrinsic novelty and interest of the subject, the highest finish of accessory art. An explanatory Appendix accompanies the Views.

PANORAMA OF CONSTANTINOPLE. Leigh.—The most picturesque city in the world is here elaborately and strikingly represented. A single *coup-d'œil* embraces the whole various and thickly-studded expanse, fringing the sea of Marmora from the shores of the Bosphorus to the Strait of the Dardanelles. The scene is busy and beautiful, and is explained by a descriptive "Companion."

THE FAMILY CLASSICAL LIBRARY has reached its Seventeenth Volume, comprising since our last notice (No. 9) the works of Tacitus, Pindar, Anacreon, Theophrastus, and Horace. The Volume (Sixteenth) containing the characters of Theophrastus, illustrated by Physiognomical Sketches, is especially calculated to attain popularity.

HINTON'S UNITED STATES.—The Numbers of this work (up to the 9th) now before us, promise a valuable and complete History of the North American Provinces. We have seldom seen more beautifully executed Views than those by which these numbers are adorned. The edifices are in a style of art hardly to be looked for in so young a country as the United States. The historical portion of the work exhibits research and correctness.

THE HARMONICON.—This is the most instructive and entertaining publication of its class with which we are acquainted. In its pages the History and Study of Musical Science are agreeably elucidated by anecdote, precept, and examples.

CABINET ATLAS.—The Twelfth Part completes the **CABINET ATLAS**, one of the most exquisite Specimens of Modern Art. A Biblical Series, to correspond, is announced.

THE NEW SPORTING MAGAZINE—FIRST NUMBER.—We are fond of the manly Sports of our Country, and are fascinated by their details. We neither ride Races nor frequent Melton; yet has the cry of a hound or the rush of a racer a spell for our ear and eye. The New Sporting Magazine fall refreshingly upon our path: it is full of promise.

THE SCIENTIFIC GAZETTE, which was established at the close of last year, as a Weekly Record of Improvements and Discoveries in Science, embraces a useful principle, and, as far as we have seen of its numbers, is creditably conducted. We do not, however, agree, either as to cause or effect, with its assumption that the vices and misfortunes of Great Britain are owing to the Decline of Science within its realms. Science and Knowledge were never more generally cultivated amongst us. The mischiefs of "a little Learning" amongst the mass may, we admit, afford matter for just animadversion at the present moment.

THE EDINBURGH CABINET LIBRARY, VOL. III.—EGYPT.—This is amongst the best of its numerous Family—and is confined to Geographical and Topographical Subjects. The First Volume, which we formerly noticed, related to the Polar Regions; the Second we have not seen; the Third, now before us, contains a View of Antient and Modern Egypt, by Dr. Russell. Reserving Nubia, Abyssinia, and the vast countries

of the Upper Nile, for a future Volume, the compiler fulfils the object of the present in a very satisfactory manner. A Map and several well-executed Engravings illustrate the text.

Haverhill; or, MEMOIRS OF AN OFFICER IN THE ARMY OF WOLFE. By James Athearn Jones.—We recollect a Work by the same Author, entitled "Tales of an Indian Camp," which displayed much imagination and ability of a peculiar description. The present publication relates to matters of fact rather than fancy, and presents a lively and accurate picture of North-American life in its rude stages, and amidst the savage grandeur of luxuriant forests, the primeval tenants of the soil. The expedition of Wolfe, terminating in the death of that Hero, forms a large portion of the action of these volumes, and is related in a very spirited and characteristic manner. The Author, from his familiarity and perfect acquaintance with the scenes and habits of a country in which he had passed several years of his life, was more than usually qualified to fill up the general outline of such a story by the minor and local details necessary to its due keeping. For the same reasons, the practical commentary introduced by the Author on the subject of Negro Slavery, and the endless cant to which it gives rise, merits attention at a moment when the mischievous meddling of a maudlin and sanctified class threatens to plunge our West India possessions into the horrors of massacre and irretrievable anarchy. The political opinions of Mr. Jones, are marked by practical good sense, and are avowed with a manliness in striking contrast with the servility to mob-government so much in vogue for the passing season.

NOTICE.—Sir Howard Douglas is preparing a New Edition of his Essay on Military Bridges and the Passage of Rivers. Much new matter will be introduced, together with the valuable Notes given in the French Translation, by M. Vaillant, Chef de Battalion au Corps de Génie, relating to operations treated of in the text.

We have still many Reviews and Notices, unavoidably postponed; but as far as the immense mass of matter on our hands will permit, we hope to do justice to all in due season. Brooke's Travels, the Life of Sir Thomas Lawrence, and other productions of a teeming press have reached us.

GENERAL CORRESPONDENCE.

TO THE EDITOR OF THE UNITED SERVICE JOURNAL.

Experiments at Brest on Marshall's Gun Carriages.

MR. EDITOR,—Having lately made some stay at Brest, the principal naval station in France, I had the good fortune to be present at the very able trials which were made there of Capt. Marshall's gun-carriages. These experiments lasted several days; and as the public have, through your Journal, become acquainted with many interesting facts relative to these carriages, perhaps the following account of what has taken place in France will be acceptable to you.

In the beginning of 1830, the attention of the French Government was first drawn to this decided improvement in mounting ships' guns. A very able and scientific naval officer at Brest, Capt. Gicquel des Touches, translated Capt. Marshall's publication, and pointed out so forcibly the merits of this invention to the Minister of Marine, that he ordered a 36-pounder to be mounted forthwith, and directed a Commission to examine and report upon its capabilities. The report was so favourable, that it was expected some of the vessels fitting out for Algiers would have been armed with these carriages, but time did not admit of this being done.

In France, however, they do not do these things by halves: towards the latter end of the year the Government decided on having a more extensive trial of this invention, but circumstances delayed it till Feb. 1831, when a commission of nine naval, artillery, and engineer officers, during four days, put this carriage to the severest tests which they could devise, and it was completely successful in all points. In elevation and trainage it obtained double the angle which was got on the old carriage, and in depression, more than treble! It was fired double-shotted without breechings or tackles after being heated by several hours' firing; and, to wind up the whole, was fired several rounds double-shotted without any breast carriage at all, the gun merely running in and out on a batten nailed to the port-sill; in fact, its total superiority over the old carriage was established in every point in the most decided manner.

Of the very able report of Capt. Gicquel des Touches, the President of the Commission, occupying nearly twelve sheets of paper, I could only copy the conclusion, as follows:—

“ It results from these experiments made by the commission charged with examining the gun-carriage invented by Commander Marshall, that this carriage possesses a great number of advantages over the old, namely:—

“ 1st, It gives infinitely greater angles, which would always give a ship armed with these carriages an incontestable superiority over one which had only the old ones, whatever may be her position, to windward or to leeward, when the breeze is fresh and the ship much heeled over, in chasing or being chased; these results are of the highest importance, and are not to be compared with the trifling inconvenience which we found in moving the breech to the right or left.

“ 2nd, The great facility of getting the extreme angle of trainage of the guns.

“ 3rd, The incomparable advantage of being able gradually, and steadily, and without shaking the decks, to point the gun at any required object.

“ 4th, Its being always ready for loading, under whatever angle it may have been fired, and its never moving its bed or quoin, however it may have been heated in a long cannonade.

“ 5th, The gun cannot kick or recoil in any but a uniform and steady course, which does not, therefore, fatigue the decks like the old one, and would permit a more rapid fire to be kept up.

“ 6th, This carriage being in two parts distinct from one another, it may be much more readily mounted and dismounted than the old one, if injured in action.

" 7th, There are several methods proposed for securing it as a lower-deck gun, and all of them are preferable to the old carriage, as they permit the whole of the guns, when it is wished for the safety of the ship, to be secured a great deal nearer the deck than before.

" 8th, It is worked with less men, viz. one-fifth in guns of large calibre, and in a greater proportion for smaller guns, and still less if a little grease is put on the crutch.

" 9th, No attention whatever need be paid to the breechings or tackles in running the gun in or out.

" 10th, The great advantage of being able to fire the gun with its fore part running in and out on the sill of the port, presuming the breast-carriage is entirely shot away and cannot be replaced by a spare one.

" 11th, Spare ones, however, take up much less room on board than on the old plan, as the breast-carriage stows inside the breech-carriage.

" The Commission, viewing all these advantages, are fully satisfied with the experiments which have been made under their eyes, but before recommending the definitive adoption of this carriage, they think it should be tried at sea; in consequence, they conclude by unanimously recommending that a line-of-battle ship and two frigates be armed with half their guns on Marshall's carriages, and furnished with the spare articles recommended by the inventor; and above all, that the captains may be ordered to profit by all occasions of bad weather at sea to try them. But in lieu of placing one of the new carriages between two of the old, the Commission think it will be preferable to place three of each together, as affording a better opportunity of viewing their manœuvring; and they also think that, where so many advantageous circumstances present themselves as do in this system both for attack and defence, all possible activity should be used to make these last decisive experiments.

" They also think the breeching bolts should be the same as are used for the carronades on the non-recoil principle, as they are much stronger. That the port scuttles should be placed opposite the mouth of the guns when placed horizontally in their crutches. That the hand-spikes for 36-pounders should be from thirty-six to forty centimetres longer. That improvements may, perhaps, be made in fixing the breast-carriage to the side, which would render it still more unlikely to be shot away. That the breeching should be rove through a hole in the carriage instead of going round the breech of the gun, and that a preventive breeching will not be needed; this will be less expensive and more simple, and do away with any likelihood of the breeching chafing against the trunnion clamps or sides of the carriage.

" (Signed)

Gicquel des Touches, Capt. de Vaisseau, President.

De Rault La Hurie, Capt. de Vaisseau.

Kerdrain, Capt. de Vaisseau.

Lunean, Capt. de Vaisseau.

Andrea de Nerciat, Capt. de Vaisseau.

Le Gal de Kervin, Capt. de Fregat.

Tronde, Capt. de Fregat.

Laonenan, Lieut. de Vaisseau, Rapporteur.

Fabre d'Eglantine, Engineer of Naval Constructions.

Taillefer, Chef de Bataillon, Artillery of the Marine.

Conseil, Capt. Artillery of the Marine.

" Brest, March 1st, 1831."

No heavier gun than a 32-pounder had been before tried on these carriages; the one reported on above was about equal to an English 42-pounder, and during the whole of the four days it was put through all its facings most completely, in presence of a number of naval and military officers, and elicited the most marked approbation from all the scientific people present; eleven men were the crew, and fourteen worked a similar gun on the old carriage. When the crutch was greased, four men run Marshall's gun out, and three run it in. They were rather unhandy in training it; the French have no sailors. The crew of both this gun and the one on the old carriage which was worked against it, were raw conscripts belonging to the corps formerly called cannoniers.

Here, then, France has, after the first experiment on a proper scale, at once come up to what England has been four years arriving at, after having tried these carriages in all shapes and manners, at sea and in harbour, and their decided merits having been warranted to her by names enrolled for ever in the deathless pages of her history as the first of her naval heroes. Capt. Marshall details in his publication the experiments made under the orders of Sir Robert Monson, Sir Pulteney Malcolm, Sir Thomas Staines, Sir Thomas Hardy, &c. &c. and since that time, Sir Jahleel Brenton officially reported to the Admiralty of that day as follows.

“ I was prevented at first from making an application for them by objections which I had heard urged against them on several points, and which appeared to me well founded.” “ On reading the report made by Sir Pulteney Malcolm and Captains Campbell, Thomson, Maitland, and Bouverie, of a trial which took place in their presence of two 24-pounders on these carriages in H. M. S. Isis in the Mediterranean, I felt satisfied that it would be expedient to have some of the Donegal's guns fitted on these carriages with a view to farther experiments, and applied for them.” “ During the summer I have caused almost daily experiments to be made.”

Sir Jahleel then arranges the results alongside of the objections he had heard against them, fully disproving every one of them; and by this report alone, if there were no others, the entire success of these carriages would be for ever established.

Sir Jahleel then goes on to state with respect to securing them—

“ In order to remove every possible objection, I caused the gun to be lifted off its breast-carriage, and the muzzle to be laid on deck, where it was effectually secured, with the additional advantage of having the weight so much lower and brought into contact with the strongest part of the ship, not only diminishing the weight aloft, but affording so much more room for the hammocks. It was at first thought that guns secured in this manner would require too much time to replace them upon their breast-carriages, but this was done to a 24-pounder by its crew in the presence of Sir Henry Blackwood and Sir John Gore in *two minutes*.”

“ Having, as I conceive, disposed of the objections, I think it right to mention what appears to me the decided advantages of the new over the old carriages, viz. The power of giving a much greater angle of elevation, depression and trainage; the great dispatch in firing; the facility and accuracy of pointing; the ease with which the muzzle is placed for loading; their being worked with at least one fifth fewer men than the old; the facility of replacing a disabled carriage, and their never displacing their bed or quoin, a very material object in the night or in smoke. The difficulty in transporting them has entirely vanished by using the spare axletree as done by Sir Thomas Staines.

“(Signed) JAHLEEL BRENTON.”

What can the Government of any country want more than this? Here is a distinguished naval officer coming forward with all the characteristic candour of his profession, and stating to the Admiralty, first his prejudices, and then the incontrovertible facts which have, after totally removing them, caused him warmly to point out that there are no objections, and that the advantages are numerous and decisive. It is also a curious fact, that the President of the French Commission, Capt. Gicquel des Touches, also at first sight conceived a strong prejudice against these carriages, which was entirely removed from his mind by reading Capt. Marshall's book, detailing the invention. This distinguished French officer was in the battles of Algiers, and in the ship which engaged the present Admiral Sir E. Codrington, at Trafalgar, &c. and is, I think, as sound a practical sailor and scientific man as I ever had the pleasure of conversing with. Just at the conclusion of the trials at Brest, he was appointed to the Guerriere of sixty guns, and immediately applied for her to be fitted with these carriages.

Since Sir Jahleel's report, another Committee have been ordered, who state—

“ After having given them every investigation in our power, we are of opinion, that they are worked with greater facility, (with fewer men,) easier pointed and to a greater extent forward and aft, and give more elevation and depression than the carriages now in use. Twenty rounds were fired double-shotted, and they answered in all respects. We fired them double-shotted without either breechings or side tackles, so as to allow them to recoil off the crutch and fall on the deck, neither the carriage or deck were in the slightest degree injured; the 24-pounder was remounted in two minutes and a half by seven men, and the 32-pounder in one minute and a half by nine men. On the lower-deck, the method of housing them is preferable to the old, from their being placed lower on the deck, and allowing a greater circulation of air and room for the crew.” “ We beg leave to suggest that one line-of-battle-ship and two frigates on active service be fitted with the new carriages for half the guns on board, and placed alternately on the ship's decks, that the captains be directed to try them on every occasion of bad weather *at sea*; and that such ships be allowed a certain number of spare articles as proposed by the inventor.

“(Signed)

Ben Hallowel Carew, Admiral.
 J. P. Beresford, Vice-Admiral.
 John Gore, Vice-Admiral.
 T. M. Hardy, Rear-Admiral.
 Samuel Warren, Commodore.
 J. W. Dundas, Captain.
 William Cuppage, Lient.-Gen. Artillery.
 William Millar, Major-Gen. Artillery.
 J. S. Williamson, Colonel, Artillery.
 J. May, Colonel, Horse-Artillery.”

To arrive at the above point has taken England four years, and France a few months. I suppose, then, that France must win the laurel, and that England must wear it second-hand. Can this be true? Will she again be left in the back-ground? When one nation adopts these carriages, all the others must, unless they mean to give away their ships to the first enemy who can get alongside of them. The cradle of mechanical genius, how often does she leave other countries to father the best of her children, and is at last obliged to take them back and cherish them, although she is shorn of the honour of their adoption: we need only look to steam-boats, for one among the many proofs of this melancholy fact, yet she still heedlessly forgets that “ *Palmam qui meruit ferat,*” the motto which she gave to her greatest warrior, would wave as gracefully over the crown of a nation, as it would float round the coronet of a hero.

Let us hope, however, that we are falling upon other days; I cannot bear to think that any but the parent country should in this case earn the palm. Thus much at any rate is certain; that splendid frigate, the *Barham*, is ordered to be entirely fitted with Marshall's carriages, of course embracing all the inventor's latest improvements, drawn from the extensive experience which he has acquired during the numerous trials they have undergone for more than two years: report says, this is to be the omega; I trust so; among the many reforms of the day, this one at least will not be problematical.

A

Lord Camelford.

MR. EDITOR,—You have laid before us some able papers on Duelling,—pray could you prevail on J. M., or any of his friends, to favour your readers with a memoir of the eccentric but gallant Lord Camelford? It would be an excellent illustration.

X. Y. Z.

Suggestion for a Cipher to be employed on Service.

MR. EDITOR,—As in military and naval operations it is often of the utmost importance to possess a cipher which can be easily varied, so as to prevent all possibility of interpretation if despatches should fall into the hands of the enemy, I beg to suggest the following as one which will answer the purpose, hoping that some of your correspondents will employ some of their leisure hours either in improving it, or inventing others more useful. Let some word or sentence be agreed on between the parties themselves only, but not committed to writing. Take, for instance, Nelson; then let an alphabet be numbered as follows:—

13	14	15	16	17	18	19	20	21	22	23	24	25	26	1	2	3	4	5	6	7	8	9	10	11	12
14	15	16	17	18	19	20	21	22	23	24	25	26	1	2	3	4	5	6	7	8	9	10	11	12	13
1	2	3	4	5	6	7	8	9	10	11	12	13	14	15	16	17	18	19	20	21	22	23	24	25	26
A	B	C	D	E	F	G	H	I	J	K	L	M	N	O	P	Q	R	S	T	U	V	W	X	Y	Z
23	24	25	26	1	2	3	4	5	6	7	8	9	10	11	12	13	14	15	16	17	18	19	20	21	22
16	17	18	19	20	21	22	23	24	25	26	1	2	3	4	5	6	7	8	9	10	11	12	13	14	15
9	10	11	12	13	14	15	16	17	18	19	20	21	22	23	24	25	26	1	2	3	4	5	6	7	8
14	15	16	17	18	19	20	21	22	23	24	25	26	1	2	3	4	5	6	7	8	9	10	11	12	13

Then the first letter (N) is to be the key of the first despatch, or the first line of such despatch if preferred; the second letter (E) of the second, and so on. It will be seen that the letters of the Alphabet are first numbered according to their proper order, then N is taken as No 1, O 2, P 3, and so on up to 26. The same thing is done with each letter of the word, which is to be the key-word previously agreed upon. When any communication is to be made, it is only necessary to see what number the first letter would be in the natural order of the Alphabet, and then to see what number will correspond with it when the first letter of the key-word is taken as No. 1. Then substitute for the letter intended to be expressed, the letter corresponding to the last mentioned "number." For instance, "March to-morrow morn," is to be conveyed. Nelson the key-word. "M" is the thirteenth letter of the Alphabet, but "N" being the key letter, and taken as No. 1, "Z" will (by this arrangement) be the thirteenth letter, and consequently be substituted for "M," and so on with the rest. The key letter of the next line or next despatch, as the case may be, will be E, and so on. Thus, "March to-morrow morn," will be in cipher,
 ("N" being key) "Znepu gbzbeebj zbea."

Or, ("E" being key) "Qevgl xsqsvvsa qsvr."

I hope I have made this plain enough to be understood by the help of the numbered alphabet above. But to remove all difficulties, let us suppose a person receiving the first cipher communication znepu gbzbeebj zbea, N being key, he will thus proceed. Counting (see alphabet above) N as 1, he will find Z to be the thirteenth letter: the thirteenth letter of the common alphabet being M, he will read M for Z; counting N as 1, A being the first letter of the common alphabet, instead of N, he will read A, and so on. In order to render detection still more difficult, the letters may be written continuously without dividing the words, or even dividing the words wrong, so as to read when interpreted "marchtomorrowmorn," or "ma rehtom or rowm orn;" this would easily be read with a little practice.

It will be seen that this cipher may be greatly varied, but its chief advantage is that the key will always be a word, sentence, verse, &c. agreed upon previously, and which need never be written, so that its discovery will be impossible. I rather think Napoleon used with success whilst at Elba a cipher of this kind, but I never saw it, so cannot be certain. There will be no papers to be kept secret, as unless the key-word be betrayed, which may be different for every day in the year, it cannot be deciphered.

H.

Remuneration for Shipwreck, &c.

MR. EDITOR,—Can any of your numerous readers assign the reason why no remuneration is given to those who lose all, except their lives, by shipwreck? A military officer is very properly paid for any losses which he may sustain either on shore or on board; but a naval officer never receives one farthing, whether he loses his whole stock by shipwreck, or has the standing part of them destroyed by shot or shell, as has happened to me more than once, including valuable nautical instruments, and telescopes, perhaps of “100-horse power.”

Some people say, “They don’t give you anything when you are shipwrecked, because if they did, you would not mind losing a ship, in a comfortable way, every time you wanted a new set of rigging; and as to the shot holes, your prize-money will find you plugs enough for them.” With respect to the first part of the argument I should say, “No, messmate, just the reverse; those who like may care for the ship when she gets on shore, let me save my chest if you please; there are plenty more ships to be had for commissioning, but a new chest of traps, to my sorrow, must be paid for;” and as to the latter part of the reason, do not the hardest knocks generally accompany the smallest pickings? What prize-money do we get for engaging stone walls for instance? or does a hard-fought action against a superior force, line the pocket so well as one of your Yankee Bordeaux-men, who are to be had for the catching?

No, let the enemy’s men-of-war alone, say I; let them take all they can; my business is to re-capture them: the salvage of a recovered friend, is worth more than the whole hull of a foe, and is to be had without any unshipping of legs and wings. Many a good hammering have I had, without even the hopes of any blunt; and in one of my first cutting-out expeditions, I had a new pair of blue trousers done for (price thirteen dollars,) while my prize-money was three pistareens (two shillings and five-pence); I might have had them mended, to be sure, but I did not like to say much about it, because, like the old Polyphemus, I was shot in the ———.

If no better reasons than these can be given for such a mode of treatment, I hope among the other improvements of the day, that this matter will get a little overhauling. I should have lost more than I did, at Algiers in 1816, if I had not slud my chest three times during the action, to keep it end-on to the batteries; but one does not always have the chance of doing this. I tracked a four-and-twenty pounder afterwards, and found that if I had not taken the above precaution, my gentleman would just have astonished my remaining three clean shirts and two pair of white mustering trowsers; and somehow or other, I never knew one of these intruders enter a midshipman’s chest without breaking his blacking-bottle; dad may therefore think himself lucky if he gets off with a pound in hard cash for every pound weight of the shot.

What is harder than everything, although we seldom think much about it, is, that when we lose the number of our mess, as well as our kit, our heirs are never paid a single farthing for the latter loss, even when they are not entitled to any pension. I think when a man rigs his son decently out in the world, to be killed like a gentleman, the least which the country could do, would be to pay the old boy for the damages done to his departed brat’s stock in trade, after he has been at such an expense to enable him, as the boatswain says, to “extinguish” himself.”

Yours, &c.

L.

Means of Preserving the Health of Soldiers.

MR. EDITOR,—It is not perhaps generally known to the readers of the United Service Journal, that in the year 1763, Dr. Richard de Hauterscerk, Inspector of Hospitals in the French Army, represented to the Duc de Choi-

seul, Secretary of State for the War Department, that it would be of much advantage to the service if the medical officers attached to the hospitals were obliged to render a regular account of their practice, and to correspond with the Inspector respecting the health concerns of the troops under their medical charge. The Duke soon perceived the utility of the measures which had been suggested, and directed that it should be carried into effect. Dr. Richard was appointed to collect the various communications from the medical officers, with authority to publish those which he might deem of sufficient importance. In 1766, the Inspector published a quarto volume containing selections from the communications of the medical officers, entitled *Recueil d'Observations de Médecine des Hospitiaux Militaires*. This volume contains an excellent code of instructions to medical officers from the pen of Dr. Richard; he strongly recommended that they should devote much attention to the study of medical topography, and especially to make themselves intimately acquainted with the salubrity or insalubrity of garrison towns, barracks, prisons, and hospitals. He published also models for drawing up cases, describing epidemics, &c. and a few topographical essays. The second and last volume of this series, which appeared in 1772, contained four topographical memoirs, five memoirs upon epidemical diseases, and a number of valuable papers on the practice of medicine and surgery, with several communications on pathological anatomy.

Dr. Richard had thus the merit of drawing the attention of Government to the importance of the medical branch of the service, and of showing that the talents and usefulness of medical officers may be greatly improved by the publication of an account of their professional labours. The judicious exertions of the Inspector seem to have been duly appreciated by the King of France; he was made a Knight of the Order of St. Michel, and his estate of Hauterscerk was entered into a Barony. In 1781, Marechal de Seguin, Minister at War, directed that the publication of selections from the correspondence of the medical officers of the army should be recommended, and that the communication should appear in the form of a Journal, to be published every three months, under the following title, *Journal de Médecine, de Chirurgie et de Pharmacie Militaire*. This periodical was intended to be solely devoted to reports on the means of preserving the health of soldiers, and of treating them under disease. The first number appeared in 1782, and the last of the series was published in 1789. The collection consists of seven volumes in 8vo; many of the communications in this series are very valuable, more especially those that relate to the means of preserving the health of soldiers, and of rendering an army efficient. The publication of the communications from the medical officers was suspended until 1815, when the Minister at War decided that they should appear in a Journal to be published every two months. He addressed the medical officers by a circular letter, in which he assured them that their communications would be carefully examined, and that the merits of each should be impartially estimated. The avowed object of the Journal was,

1st. To promote the improvement of the art of healing in as far as regarded the treatment of soldiers, and to circulate useful information among physicians, surgeons, and apothecaries belonging to the army.

2ndly. To excite and preserve a spirit of emulation among medical officers by affording them an opportunity of displaying their talents and zeal.

The Journal was to contain the official communications which regarded the medical department, issued by the Minister at War, and a portion of each number was to be devoted to medical intelligence, such as short notices of new works, recent discoveries connected with military medicine, biographical sketches, &c. Two volumes of this series were published in the form of a Journal in 1815 and 1816, the succeeding volumes have been published entire, under the title of *Recueil des Mémoires de Médecine, de Chirurgie et de Pharmacie Militaire*. This series is still in progress. The last volume I have seen is the twentieth, which was published in 1826, so that about two volumes appear annually. The current series contains, a vast collection of

valuable information upon the various topics connected with the health concerns of an army. It is impossible to estimate too highly the contribution of Dr. Birou (*Secrétaire du Consul de Santé*). They comprehend an excellent code of instructions for preserving the health of soldiers, and for rendering an army efficient. It is greatly to be regretted that a similar plan for diffusing useful information among medical officers of the British army has never been adopted; and the object of the present communication is to excite attention to this subject. The advantages and practicability of the measure are so obvious, that it would be a work of supererogation, and no compliment to the understanding of your readers, were I to obtrude arguments in its favour: we are, it must be admitted, seventy years behind the French in this respect; now we ought to anticipate them. The medical officers of the British army are not individually inferior to the French in talents, professional acquirements, or zeal; all they require is a facility of communicating information; and a "new excitement to emulative exertion." "No man is independent of external stimulus, and the surest method of annihilating energy is to leave it to prey upon itself." From the varieties of countries occupied by the British army, and the different races of mankind which compose it, medical officers have a much more extended field of investigation than the French. There is not a military hospital in France which affords such excellent opportunities for the study of chronic diseases, as the general hospital at Chatham. Money is useful only when it becomes current, and its usefulness is in proportion to the extent of the circulation; the same may be said of intellectual wealth.

The East India Company deserves the thanks of the public for having printed three volumes upon the epidemic cholera, being an account of this disease as it appeared in the Bengal, Madras, and Bombay Presidencies; but why were these volumes not *published*? Was it intended that the information they contained should be limited to a few favourites, on whom they were bestowed as presents? This is not the plan adopted by the French Government under similar circumstances.

In 1828, an 8vo. volume was printed, containing "a series of tables exhibiting the results of disease in the different European regiments serving under the Madras Presidency and in the garrison hospitals of Madras and Poonamalie, from the commencement of the year 1820 to the end of the year 1826, with observations on the practice employed in fever hospitals and dysentery, extracted from the half yearly reports of medical officers in charge during the periods embraced by these tables respectively. The whole arranged by the medical board, and published under the authority of Government."

This volume was printed, but if my information be correct, it was not in the ordinary sense of the term *published*; for what reason its circulation was so limited I cannot conjecture. The following inscription I find on the fly leaf of a copy now lying before me, "*Presented by the sanction of Government to (name of the donor) by the Madras Medical Board,*" from which I infer that no individual is entitled to procure a copy without "the *sanction of Government.*" This is a novel mode of publication. In the "prefatory memorandum" to this volume, the Madras Medical Board professes to "have it in view to prepare for publication a series of tables, exhibiting the general results of disease in the European regiments serving under this Presidency from the year 1803 to the commencement of the period embraced by the present publication, accompanied with abstracts of such information from the cases and reports connected with these tables, as may be found calculated to illustrate the practice in use at the time in the principal diseases." I sincerely hope this projected series of tables will not only be printed but published, so as to enable the members of the medical profession in this quarter of the world to procure copies, although they may not have it in their power to obtain the "*sanction of Government*" for that purpose.

I remain, &c.

BLANK.

India Army—Tardy Promotion.

MR. EDITOR,—An extraordinary contrast exists between the promotion of the officers at St. Helena and those of the three Presidencies in India. St. Helena can, I regret to say, boast of the senior officers in the following grades:—

ST. HELENA.		BENGAL.	
Lieut.-Colonel, 8th June 1815		Lieut.-Colonel	1824
Major, 30th November 1811		Major	1825
Captain, 10th January 1808		Captain	1817
Lieutenant, 17th April 1814		Lieutenant	1818
MADRAS.		BOMBAY.	
Lieut.-Colonel	1824	Lieut.-Colonel	1824
Major	1824	Major	1825
Captain	1816	Captain	1818
Lieutenant	1817	Lieutenant	1818

Although in the three Presidencies of India the number of officers amounts to 4707, and at St. Helena to no more than 37; we are, I am grieved to say, nine years behindhand with the Lieut.-Colonel, thirteen with the Major, eight with the Captain, and three with the Lieutenant; and what is exceedingly humiliating, we are not allowed any Brevet Rank excepting that of Captain to Subalterns of fifteen years standing. The Brevet of 1830 included all Captains up to December 1812; but poor St. Helena is deprived of this advantage, though we have a Captain whose commission bears date January 1808, and who served the Honourable Company in a military capacity upwards of forty years in this island. Our limited enjoyments of Brevet Rank is certainly a severe case, as the Crown is willing to grant this boon without incurring any additional expense to our honourable employers. And farther, if the Captain above mentioned had been in the King's Service, he would have been a Brevet Major in July 1821, when Captains of 1808 received that rank; and in consequence of this benefit not extending to St. Helena, this old meritorious officer was superseded in the garrison by an officer *thirteen* years junior to him in the service. I think it also a singular circumstance, that although the officers of the Royal Artillery and of the Artillery in India receive greater pay than those of the line, yet at St. Helena there is no difference made between the salaries of the Artillery and the Infantry. Why is this?

St. Helena, 19th March 1831.

I am yours, &c.

MILES.

Uniform of the Unattached.

MR. EDITOR,—Having been repeatedly asked by foreigners, whether the "Unattached" was not an inferior branch of the service, from the circumstance of its being the only British uniform without lace, I beg to suggest, through the medium of your popular Journal, that it should be so far assimilated to the line, as to prevent the possibility of such a mistake in future, and also to leave no excuse for making *fancy additions* to it, which most officers are now in the habit of doing on going abroad. The expense of such an improvement would be too trifling to merit consideration, and if it should be thought that the *button* does not sufficiently distinguish the "Unattached" from their more fortunate brethren "in activity," the lace or embroidery might be put on *round* the collar and cuff, as it used to be on that much admired uniform the old undress of the Guards.

I am, Sir,

Your obedient Servant,

ONE OF THE UNATTACHED.

London, May 12th, 1831.

Deccan Prize-Money.

MR. EDITOR,—In your valuable Journal for March you did me the favour to insert a few lines respecting the *non-payment* of the Deccan prize-money. To whatever cause the delay is owing, it is justly due to the public that it should be explained. The most anxious expectation has been entertained for the last six months that the distribution would have been made, in pursuance of the order of the 20th of October last, and in accordance with the answer given by Mr Arbuthnot in the House of Commons.

I cannot doubt that if a proper representation was made on the subject, by those more immediately interested, to the Lords of the Treasury, it would be the means of producing an early performance of the order that has been issued, or the assignment of an adequate reason for the postponement. By throwing out this hint, you will confer a great obligation on every one concerned.

London, 15th May 1831.

Yours, &c.

AN OFFICER.

A Point of Etiquette.

DEAR MR. EDITOR,—I appeal to your sensibility and justice, to put the newspaper people right, in their reports of court-days; for this is the order in which these stupid men marshal the gentlemen officers.

1 Admirals.	5 Commanders.
2 Generals.	6 Captains.
3 Colonels.	7 Lieutenants.
4 Majors.	

Now, dear Sir, as they put all the Post-Captains on No. 6, pray how is Mrs Grundy to know the respective ranks of their ladies and the wives of ensigns of the militia, or volunteers? who you know, dear Sir, are all called

CAPTAINS.

Trafalgar-Place, Devonport.

A POST-CAPTAIN'S WIFE.

We have also observed that, of late, Naval and Military Officers have been hustled from their former station in the aforesaid lists, and placed below the mob of "Messieurs." Is this a sign of the Times?—Ed.

Remarks on the Proposition for a United Service Medical Society.

MR. EDITOR,—I was much gratified on perusing in your last Number, the proposals for the establishment of a *United Service Medical Society*, conceiving that were such an institution formed, great benefits would take place from the constant interchange of opinion that would necessarily arise in the discussions of the cause and treatment of various diseases, particularly those of foreign climates, respecting which, I am sorry to say, very few young medical officers on their leaving England have any acquaintance, and this defect of professional knowledge is only felt at the time it is required. Now, a great improvement in this respect would take place from their being able to obtain the advantages arising from the experience of their seniors, who have spent, in all probability, a long series of years in practically acquiring this information. But I would take the liberty of suggesting to the promoters of this measure, the propriety of admitting as members, the medical officers of merchant-vessels, for example, those of the East and West India Companies, South Sea Vessels, Hudson's Bay Company, the Greenland and Davis's Straits Vessels engaged in the Whale Fishery. Most of these gentlemen being employed for many months in the year, and several for three or four years in a single voyage, must be men of practical information, which, if but concentrated under the same roof, would speedily lead to the improvement of the healing art. By your inserting this in the next number of your valuable Journal, you will oblige,

Your obedient servant,

H. W. DUDHURST,

Surgeon, Lecturer on Human and Comparative Anatomy.

May 5th, 1831.

Addresses and Orders on the occasion of the 16th Regiment leaving Ceylon.

MR. EDITOR.—As all records of the good conduct and discipline of our regiments on foreign stations should possess an interest with the service generally, and be recorded to the credit of the particular corps, perhaps you will have the kindness to insert the following addresses to Colonel Ximenes, on the 16th Regiment's leaving the island of Ceylon, with his replies, and the accompanying General Order issued on the occasion, in an early number of your professional Journal; by doing which, you will much oblige

A FRIEND TO THE CORPS.

“ To Colonel Ximenes, Commanding H. M.'s 16th Regiment, and Commandant of Point de Galle.

“ SIR,—We, the undersigned Burgher inhabitants of Galle, respectfully beg leave to present this our humble address to you, on your approaching departure for Calcutta, expressing our heartfelt thanks for the kind protection we have gladly experienced since your arrival in this place as Commandant of the garrison, for a period upwards of two years, during which time we have, to our great satisfaction and comfort, lived in profound peace and harmony, without meeting with the most distant interruption from any one individual of the corps you have the honour to command; owing to the strict observance of discipline you have happily established in the regiment, which we heartily hope they will always continue to evince proofs of their exemplary conduct to your approbation.

“ We cannot conclude this our imperfect address without most sincerely assuring you that we unfeignedly regret your departure and that of the regiment, as we are perfectly aware that they cannot be easily equalled; and we beg that our warmest thanks be given to the officers and men of the regiment. Wishing you and Mrs. Ximenes and family health and prosperity for a series of years, and that your present voyage be attended with every happiness and a speedy passage to your destined port, is the earnest prayer of,

“ Sir, your most humble and very obliged servants.”
(Here follow forty signatures.)

“ To the Burgher Inhabitants of Point de Galle.

“ The address which you have been good enough to present to me, on the occasion of the approaching departure of the 16th regiment for Bengal, affords me the highest gratification.

“ I derive peculiar satisfaction from the encomium which you have bestowed on the regularity and good behaviour of the corps which I have the honour to command; a tribute of applause, the value of which is much enhanced in my estimation, by the great respectability of conduct and character which distinguishes the individuals from whom it proceeds.

“ The officers of the regiment unite with me and Mrs. Ximenes in returning our best thanks for your obliging address, and we bid you farewell, with the most sincere good wishes for your happiness and prosperity.

(Signed) “ D. XIMENES, Colonel and Commandant.
“ Point de Galle, Nov. 17th, 1828.”

“ The Address of the undersigned Dutch Inhabitants of Galle.

“ To, Colonel Ximenes, H. M.'s 16th Regiment, Commanding Galle.

“ SIR,—Allow us the liberty we take in expressing to you our deep regret at your approaching departure. The exemplary manner in which you have exercised the duties of your high station as commandant of this town, calls forth the universal acknowledgment of the community, and we, as a part of it, beg to assure you of the general satisfaction it has yielded; and we beg to add, that while we contemplate you in your private character, the whole tenour of it was such as to have left in our hearts indelible impressions of your worthiness, and has raised in our minds an esteem for your person, which it will be long ere it be effaced.

“ We avail ourselves of this opportunity to wish you and family health and

every happiness, and that you may speedily and safely reach your destined place, is the sincere prayer of those who have the honour of calling themselves,

“ Sir, your most obedient and very humble servants,
(Here follow thirty-six signatures.)

“ Galle, 14th Nov. 1828.”

REPLY.

“ The tribute of respect and esteem which I have just had the gratification of receiving from so large and respectable a portion of the Dutch community of Galle, has afforded me such pleasure as I find it difficult to express.

“ I feel truly happy, that my humble endeavours, in my situation as Commandant of this garrison, to ensure the peace and comfort of its inhabitants, have met with success; and I trust they will believe, that in whatever part of the world I may chance to be thrown in future, it will be a source of extreme satisfaction to me, to hear of the happiness and prosperity of themselves and families.

(Signed) “ D. XIMENES, Colonel and Commandant.
“ Point de Galle, Nov. 15th, 1828.”

GENERAL ORDERS.

“ Head-Quarters, Colombo, 22nd Nov. 1828.

“ No. 1. The Lieutenant-General cannot allow the 16th Regiment to leave the island, without an expression of his high approbation of their conduct and discipline during the period of nearly nine years that they have been stationed in it under its zealous and able Commanding-officer, Colonel Ximenes, aided and supported by so excellent a corps of officers, and with so much *esprit de corps* pervading all ranks. The Lieutenant-General feels confident that the 16th will continue to maintain the high reputation which it is so justly entitled to.

T. B. GASCOYNE,
D. C. C. G.

Query respecting the First Naval Engagement in the French War of 1744.

MR. EDITOR.—I have heard it stated, that the first sea engagement in the French war of 1744, was fought by Capt. John Emerton, in command of one of the Honourable South Sea Company's ships, and that, after an action of some hours' duration, the enemy was beat off with great loss; if you, or any of your naval correspondents, can give any information on the subject with respect to ships' names, number of guns, men, loss, or other particulars, it would afford much satisfaction to a member of the family, and confer a particular obligation on,

Mr. Editor,

Your humble servant,
INVESTIGATOR.

March 16th, 1831.

Murder of Captain Logan 57th Regiment, by the Natives of New South Wales.

MR. EDITOR.—The accompanying documents, relating to the melancholy death of Captain Logan, of the 57th Regiment, recently murdered by the Natives of New South Wales, having just reached this country, I beg to put them into your hands for insertion in the *United Service Journal*.

Your obedient servant,

27th May, 1831.

T. W.

Moreton Bay, 8th November, 1830.

SIR,—I have the honour to communicate to you the painful and distressing intelligence of the death of Captain Logan, who was surprised and killed by the Blacks, while on a journey of discovery, about three weeks since.

As the only remaining 57th Officer now at Moreton Bay, I thought it my duty to communicate to you at length the following melancholy particulars of the last days of a much-lamented friend and officer of the regiment.

Captain Logan's object on the late journey was, to lay down correctly on his chart the windings of the river between the Pine Ridge, Lockyer's Creek, and the Brisbane Mountain, and to ascertain more correctly the course and termination of a creek striking out of the main river at the foot of the Bris-

bane Mountain, in a North Easterly direction, and afterwards, (if he met with no obstacles,) to proceed to the Pumice Stone River, and the Glass-houses, and from thence back to the Settlement. On Saturday 9th of October, he left this place, and reached the Lime-stone station the same night, distant overland twenty-five miles. The next day (Sunday the 10th) they all set out upon their journey. The party consisted of Captain Logan, Private Collison, 57th regiment, his servant, five prisoners, (all good Bushmen) with two pack-bullocks. They travelled fourteen miles this day, in a North Westerly direction, and encamped on the Lime-stone side of the river. Two or three Blacks were seen near the camp place at night. On Monday, the 11th, at seven in the morning, the party left their encampment, which was near the river, but they had to proceed four miles further up before they could ford it. On approaching the river bank at the fording place, the Blacks assembled in great numbers, upwards of 200, and covered the hill close to where they had to pass, which was on the Lime-stone side of the river, and at this place they began to show a hostile feeling, by throwing and rolling down large stones on the party on passing, but no spears were thrown. At this time Captain Logan was in advance, and finding he could not proceed, on account of the Natives, he was obliged to fall back, and wait the coming up of the party. Collison, his servant, seeing what was going forward, fired a shot over their heads to frighten them: this for a time had the effect, and they kept more aloof, but while the party were in the act of fording the river, the Blacks closed on them again; he fired another shot while in the river, which again had the effect of keeping them off. The Natives appeared to know Captain Logan, for as soon as he had crossed, they repeatedly called out "Commidy Water," intimating thereby, it is supposed, he should go back over the water. They followed at a distance all this day, hiding themselves occasionally behind trees, and in the long grass. The party then proceeded on to the place where his own horse was lost, on the former journey, and encamped about ten miles to the Northward of Lockyer's Creek, about half-way between that and Mount Irwin; here the tent was pitched for three days and two nights. On the Tuesday and Wednesday, the 12th and 13th, no Blacks seen, and nothing of any consequence occurred during this time; the men were distributed in twos in search of the lost horse, and Captain Logan was alone exploring in a North-easterly direction from the Brishane Mountain. On the morning of Thursday the 14th the tent was struck, and all went on towards the Junction, and encamped about half a mile from it. No Blacks seen, and nothing particular occurred this day. The next day, (Friday,) was employed in traversing a newly-discovered Creek. On Saturday, the 16th, Captain Logan left the party early in the morning on horseback, to explore the new Creek; he was alone on this duty all the day, and in traversing the first, he discovered a second Creek; this perplexed and retarded him for a time, and it was late when he returned from the examination of both. On Sunday, the 17th, Captain Logan said he had accomplished all that he could accomplish at this time, and by his directions, about seven o'clock this morning, they all commenced their return-journey back to the Lime-stone station. At eight he left the party, and went away alone, after having previously told Collison to make the nearest way for the junction of the river, and that he should find the party somewhere about that spot. He fell in with them betwixt twelve and one o'clock, much sooner than was expected, and remained with them about two hours, travelling in company. No Blacks had then been seen; and on crossing the river a track was perceived, which resembled that of a bullock or horse: he then told Collison to go on and pitch the tent on the side of a creek, at a spot where they had encamped twelve months before. Captain Logan then, for the last time, parted with them to trace the horse or bullock track, which led him away in the direction of Mount Irwin; at which place he had been desirous of getting some basaltic formations. Collison and the party reached the tent-spot, and encamped about four o'clock this afternoon (Sunday,) on the ground previously pointed out by

Captain Logan : soon afterwards, the men thought they heard him "cooey;" they answered him, and then waited about half-an-hour, when they thought they heard him "cooey" again: he was again answered, and four or five shots were fired at intervals during the evening, and the men fancied they heard him "cooey" in reply two or three times between the shots, but he did not return. The next morning early, (Monday, the 18th,) two men were sent down the creek to search, because it was known he must cross the creek on returning home; the men saw the track of his horse in the direction of the Lime-stone. It was then taken for granted he had gone a-head, towards the above place, after missing the party. The tent was then struck, and all pursued their journey back. On this day, Monday, about twelve o'clock, fifty or sixty Blacks made their appearance with spears, shields, and waddies. They hovered about the party shouting, getting behind trees, and endeavouring to close upon the party undiscovered. No shots were fired: they continued their course, and, in an hour or two after the Blacks went off towards Mount Irwin, which was the direction Captain Logan had taken the preceding evening. Nothing more occurred this day; and the party reached safely the same fording-place they had crossed on the Monday before. The encampment this night was chosen on the Pine-ridge side of the river, thinking some signs of Captain Logan's track might be found on that side; but nothing was seen. The men then marked the trees, and made marks in the sand at the crossing place, to attract his notice (if he had not already passed,) that he might find and know the party had gone a-head. The men walked one by one after the bullocks, to make their track more distinct: this encampment was left on Tuesday morning, and nothing occurred between this place and the Lime-stone Station, which the party reached on Wednesday afternoon.

Not finding Captain Logan at the above station as was expected, Collison, four prisoners, and private Hardacre, 57th regiment, started the next morning on a second journey to search for him. The party had light baggage, and travelled between thirty and forty miles this day (Thursday 21st), and about five o'clock in the evening, they arrived at the camp, where Captain Logan's horse was lost on the former journey. The first thing seen on reaching the ground, was the saddle laying beside a tree, with the stirrup-leathers cut asunder, evidently by a stone tomahawk, and the stirrup-irons gone. The saddle was about thirty yards from the remains of a fire; and it appeared to have been taken there by the Blacks, for the purpose of cutting it on a fallen tree. A space had been eaten round where the horse had been tethered—and there were marks where Captain Logan had taken the horse to water. It also appeared that he had roasted some chesnuts at this fire: the remains of the roasted chesnuts lay about the stump of a tree that had been burning; and it was at this place the Blacks must have surprised him, for his foot-marks were very distinct, with long strides, where he had rushed from the fire to his horse. A further search was then made, to see if any signs of struggling or violence could be found; but nothing of the sort appearing, it was then evident he must have jumped on his horse bare-backed, and made his escape: the party then returned to the Lime-stone Station, without having seen a Black on the whole journey. Being disappointed a second time in not finding him there, another party went out, consisting of five soldiers of the 57th and twelve prisoners, to traverse the country all about the junction. The second day, (Tuesday,) after leaving the Limestone Station, they fell in with another traversing party under the direction of Doctor Cooper. Both parties united and travelled together. On Wednesday they reached the place where the saddle was found: Collison, two prisoners, and one soldier, then separated from the rest, and on searching about this part they found a place where the Blacks had resorted to, but there had been no camp: it was on this plain that the back part of Capt. Logan's waistcoat was found covered with blood: part of his compass was also found, as well as some leaves of his note-book. Nothing else being discovered at this spot, they returned back to the remainder of

the party. On the following morning, (Thursday,) Doctor Cooper, Collison, and five or six men, left the camp on another search, and after travelling about a mile, the Doctor smelled something very unpleasant; he made towards it, and on approaching a small creek with shallow water, he discovered the horse dead in the bottom, covered over with boughs; it appeared a leap had been attempted over the creek, and from the way the horse lay he could not have reached the other side. The Blacks must have pursued him to this place, and the marks were those of a horse in full gallop. One broken spear only was found in the opposite bank, and *at this spot* the Blacks must have certainly closed upon him. The party then went over the creek, and about seven or ten yards from the opposite bank, the body of poor Capt. Logan was found. The back of his head appeared to have been much beaten about by waddies. The Blacks made him a grave about two feet deep, and buried him with his face downwards. The body had been carefully covered over by them, but the native dogs had scratched away the earth from his feet, which were found quite exposed. No clothes, or any of his covering, was found, except his shoes, which were left near him: the grave appeared to have been made with some care, and long sticks were laid on each side of it. The body was then taken up, put into blankets, and by stages brought to the Lime-stone Station, and afterwards by water to the settlement.

His afflicted family return to Sydney by the "Governor Phillip."

To Lieut.-Col. Allan,
Commanding 57th Regiment,
Sydney.

I have the honour to be, &c.

Signed GEORGE EDWARDS,
Lieut. 57th Regiment.

GOVERNMENT ORDER.

Colonial Secretary's Office, Sydney,

Nov. 17, 1830.

SIR,

His Excellency the Governor publishes, with feelings of deep concern, the following copy of a letter from Capt. Clunie, 17th regiment conveying intelligence of the melancholy fate of Capt. Logan, 57th regiment, late Commandant at Moreton Bay, who was murdered by the natives when completing a survey which he had commenced last year.

It would be painful to dwell on the particulars of this distressing event. Every one who is capable of estimating Capt. Logan's character, his zeal, his chivalrous and undaunted spirit, will deplore it.

He had held for a period of four years the command at Moreton Bay, a situation, from the character of the Settlement, of the most troublesome and arduous description.

He did not, however, confine himself to the immediate duties of his command, but had on several occasions, at great personal risk, explored the country to a considerable extent. And on one of these discovered a river which, in compliment to his services, was named the "Logan," as will be seen by the Government order of the 16th July 1827. No. 27.

The circumstances of Capt. Logan's death prove the ardour of his character was not to be restrained by personal considerations. His life was devoted to the public service; professionally he possessed those qualities which distinguish the best officers, and in the conduct of an extensive public establishment, his services were highly important to the Colony.

The Governor, though he deeply regrets the occasion, is gratified in expressing his sentiments of Capt. Logan's character and services. He is assured that every feeling mind will sympathize with the afflicted widow, who, with her infant family, has, by an act of savage barbarity, sustained a loss which cannot be repaired.

As a tribute to the memory of this meritorious officer, His Excellency requests that the gentlemen of the Civil Service will join the military in attending the funeral, of which due notice will be given.

By His Excellency's command,

(Signed) ALEXANDER M'LEAY.

(A true Copy.)

J. ALLAN, Lieut.-Col.
Commanding 57th Regiment.

EDITOR'S PORTFOLIO;

OR

NAVAL AND MILITARY REGISTER.

AFFAIRS AT HOME AND ABROAD.
 — The Dissolution of Parliament has suspended the principle and beaten down the practice of Free Representation in these Realms. In a vast majority of the New Elections the Mob have been the Nominees, returning, at the point of the bludgeon, a herd of pliant Creatures, "bound hand and foot" to serve as the passive instruments, and syllable the will and wisdom, of their Liege Lords. The New Parliament will consequently resemble rather a Convention of Delegates representing a single and the lowest order, than a Deliberative Assembly constituted by the various classes of the nation. How far its decrees may be sanctioned by the great body of the British PEOPLE (in the true sense of that much abused term,) remains to be seen.

One singular result of the New Elections, contradictory in a signal manner of their avowed objects of "Reform," appears in the fact, that the existing system has proved in the late struggle sufficiently elastic for the utmost *elans* of the "Liberal" or Democratic principle. Here, at least, it has "worked well"—Reformee and Reformer at one and the same time! This is assuredly an unexpected property of a system so "rotten." But is there no rottenness in the puppets of the system? Where has lain the vaunted "virtue" of "The People" on former occasions? Dazzled as we are, forsooth, by its present blaze, how comes it that a light so pure should have been hitherto hidden

under a bushel? Is there no room for Reform amongst the immaculate Electors, and must the Constitution alone suffer for the vices of a Constituency betraying the most flagrant corruption in those ranks which are the most clamorous for the "Reform" of every thing—but themselves?

As an offset to the preponderance of mere unreasoning clamour, and the logic of physical force during the nomination of the New Parliament, the decided verdict of the three Universities—Oxford, Cambridge, and Dublin—each returning Constitutional Representatives, affords ground of congratulation. This honourable fact proves, that where the exercise of deliberate opinion was permitted, reason asserted its just predominance over transient passion.

It is especially painful to note the moral degeneracy and political Decline of a Great Nation; but we are bound to record that our Revolution has commenced amidst scenes of savage atrocity and sanctioned intimidation at Home: while Abroad it is hailed with complacent scoffs and malicious anticipations by our chuckling and no longer envious Rivals.

The state of Ireland generally is unsettled, that of certain districts is frightful. The fruits of eternal agitation are apparent in a state of excitement now beyond the power even of the Arch-Agitator to control. In Clare and the adjoining Counties the combined Peasantry have displaced the authority of the Law, and exercise a despotic and

almost undisputed control over the lives and properties of the respectable inhabitants of all persuasions. In other times, perhaps, this Rebellion would have been suppressed with a prompt and strong hand; but in the liberal spirit of the hour, indiscriminate murder and incendiarism exercised upon every obnoxious resident, the massacre of devoted soldiers and policemen, the suspension of business and labour, and, to crown all, pestilence and famine, produced by these very causes in combination, are looked upon with folded arms as harmless ebullitions or wholesome eruptions which purify the Body Politic! In this philosophic course shall we probably proceed till the Body Politic itself be dismembered, and the isolated Heart of the System, bereft of sound support and vital energy, be paralyzed and stagnate!

FRANCE. — Each revolution of the moon produces some new movement—some clash and culmination of the troubled waters of society in France. The squabbles of children for their brittle baubles are not more inept and restless than the caprices and conflicts of this crazy People. An Ordonnance of the King for regulating the Distribution of a certain Decoration, to be conferred upon the hole and corner Heroes of the "Three Days," and meant to produce a highly popular effect, was interpreted of course in a different spirit by the patriots aforesaid, who made the Revolution, as they frankly proclaim, by no means for King Philip, but for certain little projects of their own. Hence, another trooping of the Mob, and a counter-display of force and gasconade on the part of the Perrier Government. La Vendée is again in arms, and the French King has been making a Tour of Conciliation through the Northern Provinces.

The probability of a war be-

tween France and Austria appears to gain ground.

The Sceptre of BELGIUM remains still in the market, neither finally rejected nor accepted by Prince Leopold. In consequence of the restlessness of the Belgians with regard to the Duchy of Luxemburg, and their incessant aggressions on the Dutch frontiers, the Commissioners of the Mediating Powers have addressed a Paper to the Belgian Congress, couched in stronger and more explicit terms on those points. At Antwerp, some offensive works having been carried on towards the citadel, contrary to the spirit of the Armistice, General Chassé, with the decision which has stamped his command throughout, made a sortie from the citadel, and took possession of the Lunette of St. Laurent upon which those works were *appuyed*. That commander has farther threatened to repeat the bombardment of Antwerp, should farther provocation justify such a measure.

POLAND. — Circumstances have again retarded the decisive shock between the Russian and Polish armies—but the relative situation of each proves both that it cannot be far distant, and that the superiority rests with the former.

After the operations described in our last, Count Diebitsch, having made fresh arrangements, again advanced upon Warsaw, threatening, as we anticipated, the right flank of Skrzynecki, who retreated with deliberation before him. The Russian Commander, however, at the moment when his adversaries had summoned their best energies and last resources for a final struggle, and when the prize appeared at least in view, was compelled by the exhausted state of the country, and the prevalence of disease amongst his troops, suddenly to discontinue his forward movement, and again retire upon his convoys.

In the mean time, the corps of the enterprising Polish partisan, Dwernicki, who had been operating a successful diversion in Volhynia, was hard pressed by the Russian General Rudiger; and having been forced to retire within the Neutral Territory of Galicia, was constrained to lay down its arms, according to international law, and submit to the Austrian Authorities. Having placed his opponent *hors-de-combat*, Gen. Rudiger's corps is of course disposable for the general purposes of the campaign, while the loss of the former will necessarily be felt by the Polish main army.

It appears that Cholera is ravaging both armies, and naturally impedes their movements by diminishing their effective numbers. The Russian Emperor having, however, resolved on the conquest of Warsaw, and subjugation of the Poles, *coute qu'il coute*, Count Diebitsch is mustering his forces, greatly reinforced, for a renewed attempt; and, on the present occasion, threatens the left flank of his gallant opponent.

THE EARL OF MUNSTER.—We have great satisfaction in noticing the elevation of Colonel George FITZCLARENCE to the Peerage—by the titles of Baron Tewkesbury, Viscount Fitzclarence, and EARL OF MUNSTER—which dignities are also entailed in remainder upon his Lordship's three brothers, in default of male issue respectively.

As a soldier of service—brave, zealous, and sincere,—his comrades in general hail the becoming advancement of Lord Munster with the cordial feeling of brother-soldiers and fellow-campaigners: while those more intimately acquainted with the manly, ardent, and indefatigable character, and well-informed mind of the noble Peer, are enabled to estimate still more highly the propriety of his unenvied elevation.

ROYAL GEOGRAPHICAL SOCIETY—April 26th.—Lieut. Washington's paper on Morocco was concluded. Its inhabitants he divides into six classes—Moors, Arabs, Shellnhs, Berebbers, Jews, and Negroes, of each of which he gives a description. No government is more despotic than that of the Sultan of Morocco, and fortunately for the country, his judgment, which in the capital is always passed in person, is generally as correct as it is summary. They have no standing army but the Sultan's body guard; and when troops are required, they are called out from among the people, but receive no pay for their services. They carry a long musket, which they use with great dexterity, and are generally sure of their aim on horseback even at full speed. The pride of the Moor, as is well known, is his horse; and Lieut. Washington speaks in high terms of this useful animal. They never dock the tails of their horses, but sometimes shave them, which gives the animal a very absurd appearance. The manes are allowed to grow, and reach from two to two and a half feet in length; and the tails sweep the ground, when they have not been subjected to the above practice. The horses are never worked till they are four years old. The general price of a good horse is 100 dollars, about 20*l.*; but they are difficult to procure; and none can be exported from the country without the Emperor's permission. The Barbary horse starts on a journey unfed, and without water. Having performed it, he is piqueted and unbridled, but never unsaddled. He is then allowed as much water as he can drink, with barley and broken straw thrown on the ground before him. He rarely or never lies down, nor sleeps; but yet he is spirited, and seldom broken-winded. The people are subject to many diseases, and are periodically visited by the plague, against which they will never take any precautions.

A communication from Capt. King, on the subject of his late Scientific Expedition to Patagonia and Terra del Fuego, was commenced. May 8th. The communication from Capt. King was concluded. On this subject a series

of interesting papers has appeared in former numbers of our Journal. Capt. King gives a concise account of the various authorities from which the charts of the coast have hitherto been constructed, and considers those of Sir John Narborough and Cordova to be the most correct. Of the southern Coast of the archipelago of Tierra del Fuego, little was known except from the accounts of the Dutch Admiral Hermite, Capt. Cook, and Mr. Weddel. The celebrated voyage of Sarmiento, which was performed at a time when the whole western coast was quite unknown, is mentioned in terms of admiration by Capt. King, for its correct description. The perseverance through all difficulties which was displayed by Sarmiento in this dangerous coast, in the old-fashioned and clumsy ships of his time, with the mutinous crew he had to deal with, has certainly never been surpassed. The Cordillera of the Andes, which extends from the north-ern to nearly the southern extremity of the continent of South America, decreases in elevation as it reaches the higher southern latitudes. In the neighbourhood of Quito, the mountains Chimborazo and Pinchincha rise to a height of nearly 22,000 feet. Near St. Jago, in Chili, the Andes are not higher than 14,000 feet. At Conception, farther south, they are still lower, and at Chiloe they average about 6000 feet. Between Chiloe and the Strait of Magellan, the height is about 3000, with some mountains in one or two places between five and six thousand feet high. The Guaianeco Islands, which form the southern shore of the gulf of Penas, formed an interesting part for the investigation of Captain King, having been the place where the Wager, one of Lord Anson's squadron, was formerly wrecked. The precise situation of the wreck, Capt. King observes, had hitherto been very vaguely known: a careful perusal, however, of Byron's narrative, and Aguero's account of the missionary voyages in 1779, will be sufficient to point out the place within a few miles. Capt. King considers it to have been on the north side, and near the western end of the easternmost of the Guaianeco Islands, and which he consequently named Wager Island. At Port Santa Barba-

ra, seventeen miles to the south of this group, a very old worn-eaten beam of a vessel was found, which was supposed by him to have once belonged to that vessel. It was of English oak, and was thrown up above the high water-mark upon the rocks at the entrance of the port. The missionaries established there have frequently found broken glass bottles, and other evident traces of the wreck of the Wager. Among the principal discoveries made by Capt. King, are two spacious lakes, which extend to a considerable distance inland from the western shore of the continent. One, named the Ot-way Water, is a large inland sea of salt water, about fifty miles in length; this communicates by a narrow channel with another, named the Skyring Water, about thirty-four miles long and twenty wide. Another opening extended to the north-west from Skyring Water, which Capt. King had not time to explore. The tracks of horses were noticed in many places on the shores of these lakes, and the bones of Guanacoes were scattered about. The mountains near the middle of the Strait of Magellan are generally about 3000 feet high, although some attain the height of 4000 feet. The line of perpetual snow in the strait was found to be about 3500 to 4000 feet above the sea. Capt. King observed that those mountains whose height does not exceed 3000 feet, are frequently during the summer free from snow, excepting in their recesses, where a large quantity is accumulated by drifting, and being protected from the effects of the sun. Capt. King mentions a circumstance relative to the temperature of the climate, which is very remarkable. During the summer he has been employed at his observatory the greater part of the night, when the thermometer has been as low as the freezing point, both within and outside of it, and although not warmly clad, he felt no sort of inconvenience from the cold; and, in the winter-time also, the thermometer has been at 24, without any inconvenience being felt. He attributes this to the peculiar stillness of the atmosphere on the coast, although at a short distance at sea, in the offing, the wind was high. There are other peculiarities

in this climate which also attracted the attention of Capt. King. One is the extraordinary warmth of the sea near its surface compared with the state of the atmosphere. In the month of June, a difference of 30 degrees was found between the temperature of each; the consequence of which is, that the sea is covered with a cloud of steam, and may in some measure account for the prevalence of fogs. Another extraordinary circumstance relating to the climate is, that parrots and humming-birds, generally the inhabitants of warm regions, are numerous in the southern and western parts of the Strait; they were even observed on the wing during a snow shower, and after a constant succession of rain, snow, and sleet; the latter have been seen sipping the sweets of the Fuschia and other flowers while the thermometer was at the freezing-point.

A letter was next read from Lieut. Glennie, dated at Guanaxuato, giving the account of a visit to the Pyramids of Teotihuacan from Mexico. Lieut. Glennie makes this place in latitude $19^{\circ} 42' N.$ and longitude $98^{\circ} 51' E.$, the variation of the needle $9^{\circ} 49' E.$, and its elevation 7492 feet above the sea. The pyramids are distant about a mile and a half from the village, the largest of which was found to be 727 feet square at its base, and height 221 feet, with two of its sides parallel to the meridian. A rampart of about 30 feet in height surrounds this pyramid at the distance of 350 feet from its base, on the north side of which are the remains of a flight of steps, with a road leading from them in a northerly direction, covered with a white cement. The remains of steps were also found on the pyramids, which were also covered with the same sort of white cement, as well as broad terraces extending across the sides. The number of pyramids surrounding the large one were estimated by Mr. Glennie at above two hundred, varying in their dimensions. They are all constructed with volcanic stones and plaster from the adjacent soil. They are coated with white cement, and the ground between their bases seems formerly to have been occupied as streets, being also covered with the same sort of cement. A smaller pyramid than that

above described was covered with a kind of broken pottery, ornamented with various figures and devices, and in the neighbourhoods of these edifices abundance of small figures were found, such as heads, arms, legs, &c. moulded in clay, and hardened by being burnt. They are collected by the Indians, and sold to persons who visit the pyramids. The Mineral del Monte was visited by Mr. Glennie, after proceeding through the town of Zempoala, which is in ruins. The place, according to the observations of Capt. Vetch, is in lat. $20^{\circ} 8' N.$ and lon. $0^{\circ} 28' E.$ of Mexico. Its height above the sea is 9052 feet. Mr. Glennie thus describes a visit to one of the mines called El Lomo del Toro, near Zimapan. It belongs to the Conde de Regla, and is one of those which are worked by the Real del Monte Company for the purpose of procuring lead for smelting the silver ore obtained from a mine hard by. The situation of this mine is very extraordinary. It is on one of the perpendicular sides of a ravine about 400 yards deep, and so narrow, that at 200 yards above the river, which flows in the bottom of it, stones could easily be thrown against the opposite side. A succession of stairs, built against the side of the ravine, enabled the mules to descend about 200 yards, when they became too steep, and the rest were descended on foot.

On the conclusion of the above papers, an interesting discussion took place respecting the fact, stated by Capt. King, of the humming-bird's being found so far south as the Strait of Magellan. That these little delicate creatures should be sporting about where the snow is on the ground, and the thermometer nearly at the freezing-point, bespeaks something very extraordinary in the climate of that part. Capt. King presented the Vice-President, Mr. Greenought, with one of these birds, which he had preserved and stuffed. The subject of the pyramids also was discussed, and the circumstance of hieroglyphic characters being on the face of some of them, was considered as analogous to those of Egypt, and that, if they could be translated, they would afford a description of various particulars relating to their structure.

THE RIVER NIGER.—The great question respecting the course of the Niger, which has puzzled geography and literature for many centuries, appears at last to have been determined. The annexed letter from Mr. Fisher, surgeon of the Atholl, well known to the world for his own interesting voyages and travels, to the Editor of the *Literary Gazette*, we have considered of sufficient authenticity and importance to extract from that esteemed Periodical.

His Majesty's Ship Atholl, at Sea, Bight of Biafra, Feb. 2, 1831.

DEAR SIR,—I take the opportunity of writing you a few lines, by a vessel that we have just now met on her way to England. My object in writing in this hasty manner is to acquaint you, that the grand geographical problem respecting the termination of the Niger is at length solved.

The Landers, after having reached Youri, embarked in a canoe on the Niger, or, as it is called there, the Quarra, and came down the stream until they reached the sea, in the Bight of Biafra. The branch by which they came to the coast is called the Nun, or Brasse River, being the first river to the eastward of Cape Formosa. On their way down the river, they were attacked by the Hibboos, (a fierce nation that inhabits its banks,) and made prisoners or rather captives; but the King of Brasse happening to be in that country buying slaves, got them released, by giving the price of six slaves for each of them. In the scuffle that ensued at the time they were taken, one of them lost his journal.

Whilst at Youri they got the Prayer-book that belonged to Mr. Anderson, the brother-in-law and fellow-traveller of the celebrated Mungo Park. They were upwards of a month at Fernando Po, whence they embarked, about ten days ago, in an English merchant-vessel bound to Rio Janeiro, on their way to England. From their taking that circuitous route, I am in hopes that this will reach you before they arrive, by which you will probably have it in your power to give the first news of this important discovery.

I do not recollect any thing else to acquaint you with that is worthy of notice; and even if I did, I have no time to mention it, as the boat by

which I send this (to the vessel) is just this moment ordered away.

I must therefore bid you adieu for the present; and believe me, dear Sir, yours very sincerely,

ALEXANDER FISHER.

PRESENTATION OF SILVER KETTLE DRUMS TO THE 2ND LIFE GUARDS.—Soon after his present Majesty came to the throne, he expressed his desire of presenting the Household Brigade with some mark of his royal favour. When he understood that King George the Third had, on a former occasion, presented the Blues with a pair of silver kettle-drums, he determined to confer on each of the regiments of Life-Guards a similar honour. The drums were ordered of Mr. Key, last October; the pattern being decided on while his Majesty was at the Pavilion at Brighton.

The drums were no sooner manufactured, than his Majesty fixed an early day for presenting them; the ceremony took place accordingly on the 6th of May.

A guard of honour, composed of an equal number of the 1st Life-Guards and Blues, under the command of Captain Bouverie, marched from London to Windsor, on the 5th. On Friday morning, the 2nd Life-Guards and Coldstream-Guards marched to the little park, and formed line, facing the Eastern terrace.

The ground was kept by the 8th Lancers. The terrace being opened, was crowded with respectable spectators; of whom the Eton boys, who had a holiday given them on the occasion, formed a conspicuous part. At half-past eleven o'clock, the royal party arrived upon the ground, escorted by the guard of honour, in state uniforms. The royal *cortège* formed a brilliant spectacle: it consisted of six or seven open carriages-and-four, with outriders. His Majesty, His Royal Highness the Duke of Cumberland, His Royal Highness the Duke of Gloucester, Prince Leopold, the Princes, George of Cumberland and George of Cambridge, Lord Hill, and the Staff of the Army present, were all dressed in military uniform. After giving a royal salute, the troops formed into three sides of a square; the centre side being the Coldstream-Guards, two squadrons of the

2nd Life-Guards the two flanks, and the royal party facing the square formed the fourth side. The silver kettle-drums were carried to the ground by non-commissioned officers of the 2nd Life-Guards, and escorted by a detachment of the Coldstream-Guards. His Majesty, having called the officers of the 2nd Life-Guards to the front, made them an appropriate and elegant speech of considerable length; giving a history of the regiment, from its origin in the reign of King Charles II. to the present time; and that from their uniform good-conduct and excellent discipline in the Peninsula, where they served for two campaigns, although not called upon to take part in any general action, and also for their brilliant and heroic achievements on the ever-memorable field of Waterloo, he had great satisfaction in showing his approbation of the services of the regiment, by now presenting them with a pair of silver kettle-drums. The drums were then put on the horse, and "God save the King" was immediately played by the famous Russian chromatic trumpet-band of the 2nd Life-Guards, (the only one in England,) in which the drums performed their part with brilliant effect. The troops then marched past their Majesties, then passed by threes, and returned to their quarters. Her Majesty, and the ladies of her distinguished party, remained in their carriages during the presentation and the marching past. His Majesty and all the military officers were on foot. The day being fine, added greatly to the beauty and brilliancy of the scene. The massive and noble pile of building, the castle, the magnificent trees, now in full foliage, the extensive landscape, the military array of the troops, the dazzling brightness and reflection of the sun's rays on the cuirasses, helmets, bayonets, lances, &c. and the royal *cortège* with its escort, altogether presented a most brilliant spectacle. An eminent artist was on the ground, who will shortly bring out two or three views of the interesting and splendid scene. The officers of the 2nd Life-Guards had the distinguished honour of being invited to dine with his Majesty on that day. The Captain of the Guard of honour was promoted to a

Brevet Majority, in honour of the occasion. The dinner was laid out in St. George's Hall, and was truly magnificent. All the gold plate, plateaux, and *ormolu* chandeliers and ornaments were displayed. Between sixty and seventy sat down to dinner, among whom were the distinguished officers before-mentioned as having been present at the morning's ceremony, and also the field-officers of the Coldstream Guards, the Colonel of the 9th Lancers, and many other Officers of distinction. The effect of the dinner-table, loaded as it was by so great a display of plate, and the numerous military uniforms, orders, &c. composed a most brilliant coup-d'œil. On the chimney-piece were the silver kettle-drums, and the standards of the 2nd Life Guards; with branches of laurel. In one gallery at the head of St. George's Hall, was the band of the 2nd Life Guards: Her Majesty and the ladies of the Court appeared for sometime in the gallery at the opposite end of the hall. His Majesty made many excellent speeches in the course of the evening, and proposed the healths of the Dukes of Cumberland and Cambridge, Prince Leopold, Duke of Wellington, Lord Hill, Sir James Kempt, Earl Cathcart, Colonel of the 2nd Life Guards, the Earl of Rosslyn, Colonel of the 9th Lancers, also Lord Howe, and the Yeomanry of England. His Majesty generally ordered the tune after each toast, selecting that which he thought the most appropriate. The Duke of Cumberland proposed the health of the "Household Brigade." The party broke up, and retired to the Drawing Rooms, where Her Majesty and the Ladies-in-waiting were seated at their various works and amusements. About twelve o'clock the party broke up. His Majesty intends to have a similar ceremony at the presentation of the Kettle Drums to the 1st Life Guards. The drums cost about 1500*l.*, are very massive, of great size, exquisitely embossed and chased, and have an excellent tone. His Majesty was in good health and spirits, and seemed to enjoy the whole scene.

DREADFUL HURRICANE EXPERIENCED BY THE HON. EAST INDIA COMPANY'S SHIP RELIANCE. — The Hon. Company's Ship Reliance, on her

voyage from China, encountered a dreadful hurricane in lat 18° S. lon. 85° E. In our last number will be found a narrative of a similar misfortune which occurred to the Company's Ship Bridgewater nearly in the same latitude and longitude. The extraordinary circumstance of hurricanes occurring in two successive years in the heart of the south-east trade, has attracted the notice of nautical men, and we have been requested to give insertion to the following extracts from the log of the Reliance, as a warning to navigators in running from the north-eastward, through the southern tropic. The Reliance left Java Head on the 30th Dec. last, and got into the south-east trade in lat. 10° 30' S. lon. 101° 30' E., which blew steadily until the 10th of Jan. so as to enable the ship to run 790 miles in four days. The wind then became lighter, and veered to east and north-eastward, with fine weather; barometer 29° 90'; at noon, lat. 17° 14' S. lon. 86° 49' E. Jan. 11th, Tuesday at noon, wind north-east, and all possible sail set. The weather had a fair appearance, with some gathering clouds, but none to indicate other change than what we naturally expected—the trade-wind's return to its proper quarter of south-east, which a gradual decline of the barometer induced us to look for. At sun-set, took in the first reefs of the topsails: during the first watch, the breeze increasing, with passing clouds and quicksilver falling, all the smaller sails, top-gallant sails, and lower studding sails were taken in: towards midnight, weather more unsettled, with sudden increase of wind: the barometer falling to 29 deg. all hands were turned up to prepare for a gale. Royal yards, fore and mizen top-gallant yards, gaff and mizen top-gallant masts were got down, flying jib-boom being already in. The mainsail and mizen topsail were blunted, and attempts made to furl the fore and main topsails, but they were soon blown away: at two A. M. scudding under the fore-sail until three, when the gale being too violent, it blew to atoms in the act of hauling it up. The storm now raged with fury. Barometer down to 28° 70'. Hove to on the larboard tack; set the small pumps to work,

and rigged the chain ones. The sea had now risen to mountains, without regularity of motion. It blew a hurricane, and the many severe gales hitherto witnessed gave no idea how terrific this was; all the top-gallant masts were blown away, and the larboard quarter boat up to the mizen-top; the other to leeward soon vanished. The roaring of the wind was appalling, laying the ship on her beam-ends, and the lower yard-arms in the heavy sea, which overwhelmed and flowed over her, tearing away all her lee harricading, and nearly lifting the sheet anchor on board. Heavy volumes of water falling over us, inundated both decks (although every hatchway was well battened down), and the weight and pressure of it evidently opened the seams of the side, and water-ways, so that it found its way below. The well was narrowly watched, but no water of consequence accumulated in it, until the ship was completely water-logged; when it became necessary to work the chain-pumps, and for some hours the whole crew merely prevented its gaining upon us; then was their apprehension that a leak had sprung or butt-head started, it being too evident, by the deep colour of the water delivered, that damage had been done to the cargo; and as she lay long gunwale in the sea rolling over to leeward, left a weight too great to admit of her rising on it. But at times, when temporarily extricated from this overwhelming load, she rode comparatively easy, and without much straining; and it may be believed that the great strength of the ship, with her other good qualities as a sea-boat, added to the buoyancy of a tea cargo, saved her from imminent peril. It is surprising that either the top or lower masts stood; and, however distressing this loss would afterwards have proved, we could not but wish occasionally that the former might give way, as for some time it seemed the only means of the ship righting, when every gust blew harder, if possible, than the preceding one, and it appeared almost necessary to part with the masts to save the hull, which would have been inevitable if our fears of a dangerous leak had been verified. Willing and active as all the officers

and crew were, human efforts were vain, except in working the large pumps, and this fatiguing labour required every strength. After the day dawned, the wind changed its direction to the S. W. blowing with the same fury. The pumps merely kept the water in the well from increasing; for although, when it could be forced out, they delivered an immense quantity, great part returned back from the ship lying bodily on her side. Between 9 and 10 A.M. the severity of the hurricane abated, and the barometer indicated a favourable though small appearance of change: the ship became somewhat more upright, and was pumped out dry, which gave us the pleasing assurance that she was free from leak, and that the water that had been in her came from the excessive straining during the storm. The wind gradually drew round from noon to the N. W. with drizzling rain, and blew up again into a common gale: towards nightfall the barometer rose, the wind lessened, and the sea became more tranquil towards morning, and at daylight the quicksilver was up to $29^{\circ} 60'$, having been so low during the hurricane as $28^{\circ} 50'$. The extreme violence of the storm continued about twelve hours.

PRESENTATION OF COLOURS TO THE THIRTIETH REGIMENT.—This ceremony took place at Ashton-under-Line (the head-quarters of the regiment), on the 5th of April. The regiment being paraded, and the new colours brought to the ground, the consecration prayer was delivered in an impressive manner by the Rev. J. Handforth, the colours being held by two colour-serjeants, without being unfurled.

The colours were then handed to Lieut.-Colonel Powell, Ensigns advanced a few paces, and the Lieut.-Colonel, holding a colour in each hand, addressed them in nearly the following terms:—

“It was my intention that these colours should have been presented to you by one not more elevated in rank, but in other respects better qualified for the task, more particularly that of addressing you on such an occasion.

“Particular circumstances have pre-

vented the fulfilment of my wishes, and particular circumstances require that it should be no longer delayed. But however exalted in rank, or however talented that person might be, this I will venture to say, he could not have at heart the interest of his Majesty's service, or that of the 30th Regiment in particular, more than I have.

“An uninterrupted service of twenty-seven years in the 30th Regiment, naturally creates in me a strong and warm attachment for every thing that relates to the welfare and happiness of every individual connected with it. These, and these alone, are all I have to offer, and will, I trust, claim from you some share of honour in receiving your colours from the hands of so humble an individual.

“In presenting them to you, permit me to remind you of the very great and important trust committed to your care. Their safety should be as inviolably sacred to you as your life. They are the rallying point for every thing that is dear and honourable to a soldier. They stimulate all to a defence of their King and country, and as their loss would be attended with disgrace, so would their defence be honourable and glorious to you.

“Satisfied that in your hands they will remain unsullied (as those of the regiment ever have done), I therefore commit them to your charge, confident that you will, (as it is your duty to do,) under every danger and difficulty that may arise, protect them to the last drop of your blood. And may God Almighty assist and protect you in the discharge of so just, glorious, and honourable an undertaking!”

The Ensigns kneeling received the colours, and after they were thus confided to the regiment, and they had been taken to their proper place in the line, three rounds as *feu-de-joie* were fired—drums beating “a point of war,” between each, and at the conclusion, the band playing the first part of “God save the King.”

Line then formed three sides of a square, and Lieut.-Colonel Powell addressed the regiment in the following words:—

“Having now entrusted to your care your new colours, it is only necessary for me, in addition to what I have already said, to bring to your recollection the brilliant services, the honour and glory, heretofore achieved by the 30th Regiment, under their former banners; and I make no doubt, that when, or wherever your

King and country may call for your services, you will emulate your brother soldiers in their honourable and glorious career."

The scene was grand and impressive; a vast concourse of persons were present on the occasion. In the evening the officers gave a grand ball at the theatre, which was handsomely and most tastefully decorated for the occasion. It was very numerous and fashionably attended, and went off with great *éclat*.

ROYAL NAVAL SCHOOL.—A meeting was held on Friday, the 29th ult. at the Thatched-House Tavern, St. James's-street, London, preliminary to the establishment of a School for the education of the sons of Naval and Marine Officers. The late Admiral Sir J. S. Yorke took the chair, and a series of resolutions were passed in furtherance of this desirable object. The advantages and paramount necessity of this national undertaking were forcibly and eloquently urged by the noble and gallant individuals who moved and seconded the resolutions. Many gentlemen interested in the welfare of the navy, offered their influence in aid of the object of the meeting, which was finally adjourned to the 14th of June.

The following resolutions were unanimously agreed to.

"1st. Moved by Capt. the Right Hon. Lord Selsey, and seconded by the Right Hon. Lord Yarnborough,—That the establishment of a school, at which the sons of naval and marine officers might be educated in a manner befitting their present condition and future prospects in life, at a moderate expense, has long been felt to be highly desirable; and would be of great advantages to the navy and to the country; and that none be admitted into this proposed institution but the sons of officers holding not lower than ward-room rank on board His Majesty's ships.

"2nd. Moved by the Right Hon. Rear-Admiral Lord James O'Brien, and seconded by Rear-Admiral Tollemache,—That the whole expense for the board and education of each pupil, who will be admitted from the age of ten years, shall not exceed twenty-five pounds annually.

"3rd. Moved by Admiral Sir Thomas Williams, K.C.B. and seconded by Capt. Francis Beaufort, R.N.—That the education shall comprise all the elements of the

different branches of knowledge now taught to young people of the more respectable classes, combined with nautical instruction, and be under the superintendence of a head master, a graduate of one of the Universities, and that one of the masters of the Institution shall be a clergyman of the Church of England, to act as chaplain to the establishment.

"4th. Moved by Admiral Sotheron, and seconded by Capt. Skipsey, R.N.—That the bankers and navy agents be requested to open books to receive the names of those officers and other persons who are willing to aid this desirable object, and that the funds be raised by shares of twenty-five pounds donations, and annual subscriptions, and that such subscriptions commence on the first day of June instant.

"5th. Moved by Vice-Admiral Sir Edward Codrington, G.C.B. and seconded by Vice-Admiral Lambert,—That the King having been graciously pleased to signify his approval of the principle of this institution, and that it was deserving of the encouragement it had experienced, the First Lord of the Admiralty be respectfully requested to solicit His Majesty's most gracious patronage of the proposed institution, and that the chairman of this meeting take the earliest opportunity to communicate with Sir James Graham on the subject, and report at the next meeting his Majesty's reply.

"6th. Moved by Dr. Dobson, Surgeon of Greenwich Hospital, and seconded by Lieut. Westropp, Secretary to the Royal Humane Society,—That copies of these resolutions be printed, and inserted in the Portsmouth and Devonport Papers, and in the Times and Courier; and that the Lords Commissioners of the Admiralty and the Lords of His Majesty's Treasury be respectfully requested to forward the same to the Commanders-in-Chief on the foreign and home stations, and to the officers of the Coast Guard of the United Kingdom, and that the Chairman of this meeting communicate with these boards to this effect.

"7th. Moved by Sir Edward Codrington, and seconded by Vice-Admiral Lambert.—That the thanks of the service in general are due to Commander W. H. Dickson, for the unremitting and persevering exertions which he has used for the establishment of the proposed Institution.

"8th. Moved by Vice-Admiral Sir Charles Rowley, Bart. K.C.B. and seconded by Capt. John Tower.—That this meeting do now adjourn to the 14th day

of June next, at this place, when Commander Dickson will make a Report of the progress of the undertaking, and a Committee of Management will be appointed to further the objects of the proposed Establishment; and that Admiral Sir J. S. Yorke be requested to take the chair on the occasion, at one o'clock."

NEW TOWN OF LANDPORT, NEAR PORTSMOUTH.—The inhabitants of those suburbs of Portsmouth hitherto partially designated as Half-way Houses, having sustained much inconvenience and loss from the want of a more appropriate name, with the consent of several persons, though not resident, possessing property therein, have determined on calling that extensive district Landport, being, as they consider, more expressive of its locality than the name lately attempted to be given to it. This district will comprise all the ground on the London road from the water-works to the poor-house, leaving out Kingston Cross, Buckland, Fratton, and Southsea. The Flathouses will be included in the new town of Landport, but the hamlet near Byrley's mill will continue to be called Radmore.

RIVER GUAYAQUIL.—The tide in the river Guayaquil, in South America, runs sometimes at the rate of seven miles per hour; by which means the delusion of the apparent motion of fixed objects is very great. A vessel coming down the river with a fair wind, and under easy sail, will run at the rate of eight miles per hour, and in consequence of the narrowness of the channels in some parts of the river, is obliged to pass rather close to the shores; thus the trees on the banks appear to be flying past her at the rate of fifteen miles per hour. Notwithstanding this velocity, it is impossible to approach, within any short distance, the numerous alligators which lie basking in the mud on the banks, appearing like the trunks of dead trees. Their sense of the approach of strangers is so great, that they immediately dive into the river and are no more seen. It is seldom possible to get more than one shot at them with a musket. The ball bounds off their scaly sides as it strikes them, and they suddenly disappear in the muddy water of the river.

COMMANDERS ROYAL NAVY.—The Lords Commissioners of the Admiralty, by a memorandum dated May 1st, have directed that no officer holding the rank of Commander shall be appointed to serve as second Captain in any post-ship, unless he shall have already commanded one of His Majesty's sloops for the space of three years, or shall have served three years as first Lieutenant of one of His Majesty's sea-going ships of either of the six rated classes.

TURTLE CATCHERS ON THE COAST OF DARIEN.—At San Blas, on the Coast of Darien, a small settlement of Indians is established for the sole purpose of taking turtle. The settlement is situated among a group of kays, and has a small but very secure harbour, in which coasters may safely ride. It is under the management of three English, two American, and three Columbian traders, who make a vast profit from the shell. The quantity of tortoise-shell taken by them amounts on an average to 15,000 lbs. per year, the value of which is about 25,000*l.* The produce of their employment varies very much according to the nature of the season, as in some years they take as much as 32,000*l.* worth of shell; an enormous produce for one out of the many like establishments on this coast. It is a curious fact, that the handsomest shell, and consequently the most valuable, is stripped from the animal while living, the beauty of the shell always becoming less as the animal dies. The dreadful torture which the creature endures by the operation finds no consideration in the minds of the traders.

HUMANITY OF A BRITISH NAVAL OFFICER. While the *Confiance* steamer, Lieut. Belson, R.N. was on her passage out to the Mediterranean, with the mails, in the month of November last, off Cape Finisterre, in the middle of the night she fell in with a large ship partly dismasted. On coming within hail of the *Confiance*, her captain acquainted Lieut. Belson that she was the *Loire*, French transport, having five hundred troops on board, from the island of Guadaloupe, bound to Brest. That they were in the greatest possible distress, as, in addition to the loss of her mainmast, rigging, &c. the ship

was very leaky, and the crew nearly exhausted from fatigue at the pumps; and that unless the *Confiance* would afford them assistance, she must go down before they could reach any port. With the characteristic humanity of a British seaman, and notwithstanding his having the mails on board, Lieut. Belson determined to take her in tow: but as it was then blowing a gale of wind, with a heavy sea running, he lay by her till morning, when he succeeded in getting a hawser on board of her. The gale, however, increasing, and the ship's crew being much exhausted, and hut indifferent seamen, considerable fears were entertained of her running foul of the little bark, so that for the three following nights Lieut. Belson never quitted the deck. One hawser was carried away in towing, and he was subsequently obliged to make use of the ship's own cable, the getting of which on board in such tempestuous weather, with so small a number of men, was an undertaking of the greatest difficulty. After having kept her in tow for five days, he succeeded in carrying her into Lisbon. The French Consul at that port, gratefully sensible of the services Lieut. Belson had rendered, after returning him public thanks, reported the circumstance to his Government. The King of France, duly appreciating such an act of humanity, would have granted him the order of the Legion of Honour, but, having ascertained that he would not be permitted by his own Court to wear it, unless it had been obtained in action, ordered a handsome gold medal to be struck, and presented to him by the French Ambassador, Prince Talleyrand, through the Secretary of the English Board of Admiralty, accompanied by a suitable letter on the occasion. The inscription on the medal is as follows. On one side a likeness of the King of France; round it, "Louise-Philippe 1st. Roi des Français." On the reverse—"Ministere de la Marine." "Henri F. Belson, Lieutenant de la Marine Royale Anglaise." "Pour avoir secouru un hatiment Français dematé, et en danger de perir. 1831."

REVISED CAVALRY MOVEMENTS.—A Board of General Officers has been directed to assemble for the purpose of examining and deciding upon the Revised Cavalry Movements.

CHANGES IN THE STATIONS OF CORPS SINCE OUR LAST.—2nd Dragoon Guards from Manchester to Leeds; 5th Dragoon Guards from Dublin to Dundalk; 6th Dragoon Guards from Cork to Limerick; 3rd Light Dragoons from Leeds to Newcastle on Tyne; 10th Hussars from Prescott to Manchester; 4th Foot from Northampton to Chatham; 34th Foot Depôt from Limerick to Clare Castle; 35th Foot Depôt from Devonport to Plymouth; 47th Foot from Portsmouth to Edinburgh; 60th Foot Depôt from Clonmell to Naas; 69th Foot from Cork to Fermoy; 71st Foot Depôt from Edinburgh to Glasgow; 75th Foot Depôt from Sheerness to Chatham; 81st Foot Depôt from Chatham to Portsmouth; 89th Foot arrived from Madras; and to Canterbury; 91st Foot, first division arrived from Jamaica; and to Portsmouth; 94th Foot Depôt from Chatham to Sheerness.

ARRIVALS, SAILINGS, AND INCIDENTS IN THE FLEET.

Portsmouth.—April 17th. Arrived the Pike schooner, Lieut. Wigly, from Cork.

April 19th. Arrived the *Donegal*, 78, Capt. Dick, from the Downs.

April 20th. Arrived the *Blonde*, 46, Capt. Sir Thomas Pasley, (acting) from the Mediterranean Station; sailed the *St. Vincent*, 120, Capt. Senhouse, with the flag of the Hon. Sir Henry Hotham, for the Mediterranean.

April 21st. Arrived the *Linnet* cutter; sailed the *Pallas*, 42, Capt. M. S. Dixon, for Plymouth.

April 24th. Arrived the *Starling* cutter, from Guernsey.

April 25th. Sailed the *Meteor* steam-vessel, to Plymouth; the *St. Vincent*, 120, Capt. Senhouse, was towed out of harbour.

April 26th. Arrived the tenders *Raven* and *Highflyer*, from Newhaven, with stores.

April 27th. Sailed the *Amphitrite* transport, to the Eastward.

April 28th. Arrived the *Victor*, Commander R. Keane, from the West Indies; arrived the *Meteor* steam-vessel, from Plymouth; sailed the *Raven* and *Highflyer*, for Newhaven.

April 29th. Sailed the *Meteor* steam-vessel, for Plymouth.

April 30th. Sailed the *Snipe* cutter, on a cruise.

May 1st. Arrived the *Columbia* steam-

vessel, from Plymouth; sailed the Starling cutter, for Chatham.

May 3rd. Arrived the Raven and Highflyer cutters, from Newhaven, with stores and discharged seamen.

May 4th. Sailed the Industry transport, for Chatham and Deptford, with stores.

May 6th. Arrived the Galatea, 42, Capt. Napier, C. B. from the Havannah; sailed the Raven and Highflyer, for Newhaven.

May 8th. Arrived the Alban steam-vessel, from Cork.

May 10th. Arrived the Starling cutter, from a cruise; sailed the Columbia steam-vessel, for Newhaven.

May 12th. Arrived the Hyperion, 42, (late Sussex Coast Guard) Capt. Mingaye, from Newhaven, in tow of the Confidence and Columbia steam-vessels, to be paid off; sailed the Starling cutter, on a cruise, and the Diligence naval transport, from Deptford, with stores.

May 13th. Arrived the Raven and Highflyer, from Newhaven.

At Spithead — Donegal, Wellesley, Blonde, Pike.

In the Harbour—Asia, Royal George, Hyperion, Rattlesnake, Pearl, Victor, Brisk, Recruit, and Columbia steamer.

Plymouth. — April 18th. Sailed the Carron steamer, Lieut. Lapidge, for Lisbon.

April 25th. Arrived the Vigilant ketch, Lieut. Loney, from Lisbon, last from Falmouth.

April 30th. Arrived the Meteor steamer, Lieut. W. H. Symons, from Portsmouth; sailed the Columbia steamer, for Portsmouth.

May 2nd. Sailed the Meteor steamer, for Falmouth.

May 3rd. Sailed the Alban steamer, Lieut. Davis, for Cork.

May 5th. Arrived the Pylades, 18, Commander Hay, from Cork.

May 15th. Sailed the Druid, 46, Capt. Hamilton, for the South American station; the Orestes, 18, Commander Glascock, for North Shields.

Remaining in Hamoaze.—Foudroyant, Caledonia, Revenge, Dublin, Stag, Pylades, Royalist, and Echo steam-vessel.

Falmouth. — April 22nd. Sailed the Rinaldo, Lieut. Hill, for Rio Janeiro and Buenos Ayres.

April 24th. Arrived H. M. ketch Vigilant, Lieut. Loney, from Lisbon, and sailed for Plymouth.

April 25th. Arrived the Tyrian, Lieut. Dwyer, from Tampico.

April 26th. Arrived the Swallow, Lieut. Baldock, from St. Thomas's.

April 27th. Sailed the Emulous, Lieut. Croke, for St. Domingo, Jamaica, Mexico, and the Havannah; and the Zephyr, Lieut. Church, for the Leeward Islands.

April 28th. Arrived H. M. steamer

Echo, Lieut. Otway, from Corfu.

May 5th. Arrived the Reindeer, Lieut. Dicken, from Halifax, sailed 20th April, under jury foremast and bowsprit; sailed H. M. steamer Meteor, Lieut. Symons, for the Mediterranean.

May 6th. Arrived H. M. S. Chanticleer, Lieut. Horatio Thomas Austin, acting Commander, from Chagrés.

May 8th. Sailed the Tyrian, Lieut. Dwyer, for Halifax and Bermuda.

May 9th. Sailed the Cygnet, Lieut. Gooding, for Jamaica and Cartagena.

May 20th. Sailed H. M. ketch Vigilant, Lieut. Loney, with a mail, for Lisbon; and H. M. S. Chanticleer, for Plymouth.

Foreign.—H. M. S. Cochin, sailed from Madras for Trincomalee, 16th Dec. The Frolic arrived at Rio Janeiro from Falmouth 18th Feb. and Spey 27th Feb. The Zebra arrived at Madras from Penang Jan. 13th. The Eclipse has arrived at Vera Cruz from Falmouth. The Challenger sailed from Bombay for Malabar Sea Dec. 20th. The Alert arrived at Lima from Huanchaca Jan. 5th.

H. M. S. Dryad and Plumper arrived at Sierra Leone 3rd March. The Maidstone arrived at the Cape of Good Hope, from Mauritius, 6th Feb. The Kangaroo, arrived at Trinidad from Barbadoes 17th Feb.

The Favourite sloop of war was at Sierra Leone on the 9th March. She was to sail on the 12th for the Gambia, and the Dryad in about ten days on a cruise. The Black Joke, tender to the Dryad, captured a slaver with 300 slaves on board, on the 21st Feb. The Athol was in the Bight of Benin. The Medina was gone to Fernando Po; and the Conflict was to leeward.

The Blanche, 46, sailed from Jamaica the 14th March for Nassau, N. P. and the Grasshopper was to have sailed on the 16th for Porto Cabello, and thence to proceed to England. The Icarus had gone to Havannah; the Shannon was at Barbadoes; and the Mersey had proceeded to Vera Cruz, when she was to return to England.

The Kent and Ganges arrived at Gibraltar from Plymouth March 31st, and sailed 4th April for Malta.

The Opossum arrived at Halifax from Falmouth April 11th.

The Belvidera arrived at Cadiz from Portsmouth 19th April.

The Alligator, 28, was at Smyrna on the 2nd April.

The Pegasus, 46, has been taken to pieces on her slip in Sheerness Dock-yard, and a steam-vessel, of 800 tons, to be called the Salamander, has been begun on the same slip, the keel of the Pegasus remains, with an addition of sixteen feet for the steamer.

The Magicienne, 42, is ordered to be cut down to a corvette, similar to the Curacao.

The Admiralty has ordered that in future no pursers are to be attached to His Majesty's vessels commanded by Lieutenants, but the charge of victualling the men is to be under the direction of passed clerks.

The naval establishment at Haulbowline is ordered to be abolished, and the stores transferred to Plymouth.

Rear-Admiral William Parker, C. B. hoisted his flag on board His Majesty's ship Alfred, at Chatham, the 6th ult.

A squadron of Guard-ships, consisting of the Caledonia, 120, Prince Regent, 120, Asia, 84, Donegal, 78, Gloucester, 74, Alfred, 50, and Talavera, 74, are directed to assemble at Spithead. They are placed under the orders of Vice-Admiral Sir Edward Codrington, G. C. B. who will hoist his flag on board the Caledonia, and Rear-Admiral W. Parker, whose flag will be on board the Prince Regent. It is understood they will proceed to the Western Islands, and employ the principal part of the summer in cruising between those islands and Gibraltar, as well as the mouth of the Channel. It is expected they will put to sea in the course of the present month.

The present appointments of Lieutenants in the Navy to the Coast Guard Service, requires that officers shall be under forty years of age. The allowance to them is 4s. per day, and the appointment is for an indefinite period. It is placed entirely under the direction of the Custom-house, the appointments being in the gift of the Admiralty.

Major Graham, a brother of the First Lord of the Admiralty, is appointed Private Secretary to Sir James Graham.

Lieut. W. Meadows, R. N. is appointed Assistant to Mr. Fallows, the Astronomer at the Cape of Good Hope, which had lately become vacant by the resignation of Capt. Ronald.

Capt. Vidal has been appointed to the temporary command of H. M. Schooner Pike, for the purpose of aiding in the survey of the coast of Ireland, by carrying soundings from the land into deep water, which, with the nature of the bottom, will be of the utmost importance to vessels

coming from sea. Other important points are connected with this appointment, which it is expected will occupy Capt. Vidal during the whole of the present summer. Capt. Vidal will also pass over the ground to which he devoted so much care and attention last summer in his search for Aitkins' Rock, and will have an opportunity of verifying his former work. Too much pains cannot be taken to remove all doubts of the existence or non-existence of a danger of this nature, and although Capt. Vidal's tracks with the Onyx and Leveret passed over every position which had been assigned to it, still a corroboration of his accuracy cannot but be always desirable even at many years hence. He has been supplied with instruments and several excellent chronometers, which will enable him to ensure that accuracy which forms the character of this officer's operations in general.

COURTS-MARTIAL.

At a General Court-Martial held at Bangalore, on Thursday the 26th day of August 1830, Lieut. and Brevet-Capt. Waldron Kelly, of His Majesty's 26th (or Cameronian) Regiment of Foot, was arraigned on the following charge, viz.—

“For scandalous and infamous conduct, such as is unbecoming the character of an officer and a gentleman, in the following instances:—

“For having at Bangalore, on the 20th day of August 1830, wantonly, and without provocation, struck Ens. Wm. Hake, of the Hon. East India Company's Service, and attached to the 39th Regiment of Native Infantry, a violent blow in his face, with his clenched hand.

“For having at the same time and place, though informed by Ens. Wm. Hake that he was an officer, again violently struck him in the face with his clenched hand, at the same time making use of the most insulting language to him, the said Ensign Hake, by saying ‘You are not worth a damn, if you are worth a damn, you know where I live,’ or words to that effect.

“The above being in breach of the articles of war.”

Upon which charge the Court came to the following decision:—

“The Court having maturely weighed and considered the evidence for the prosecution, together with what the prisoner has urged in his defence, with the evidence thereon, is of opinion—

“ On the first charge, that he is guilty.
 “ On the second charge, that he is guilty.
 “ The Court having found the prisoner guilty as above stated, which being in breach of the Articles of War, does, by virtue thereof, sentence him, the said prisoner Waldron Kelly, a Brevet-Captain and Lieutenant of His Majesty’s 26th (or Cameronian) Regiment of Foot, to be cashiered.”

Approved and confirmed.

(Signed)

DALHOUSIE,
 Commander-in-Chief.

By order of the Commander-in-Chief,
 (Signed) R. TORRENS, Colonel,
 Adjt.-Gen. of His Majesty’s
 Forces in India.

GENERAL ORDERS, CIRCULARS,
 &c.

THE ARMY.

CIRCULAR.

Horse-Guards, April 6th.

MEMORANDUM.—The General Commanding-in-Chief has had occasion to observe, that in recording the minutes of the proceedings of Courts-Martial, the names of the members are frequently inserted, without the regiments being specified to which they respectively belong; an omission which might be attended with serious inconvenience.

Lord Hill therefore desires, that in the proceedings of Courts-Martial, whether general or district, to the name of each member, the regiment to which he belongs may be invariably annexed; or if he be on the staff, that his rank and situation may be distinctly stated.

The General Commanding-in-Chief has likewise observed, that the proceedings are sometimes very carelessly and inaccurately written, with erasures and interlineations, insomuch as even to render the perusal difficult. Lord Hill cannot but regret this mark of inattention, on the part of an officer employed on so important a duty; and his Lordship trusts that the present caution will have the effect of ensuring from those, to whom it may be entrusted, greater care and circumspection in the discharge of it.

By Command of the Right Honourable

GEN. LORD HILL,

Commanding-in-Chief,

JOHN MACDONALD, Adj.-Gen.

YEOMANRY CAVALRY.

(We are happy to be enabled to furnish our friends of the Yeomanry Cavalry with the following official regulations recently

promulgated for their guidance, and which may be considered the constitution of that useful and patriotic body.)

REGULATIONS AND ALLOWANCES FOR
 THE YEOMANRY CAVALRY, BY AUTHORITY.

Establishments.

1. No troop is to consist of less than forty, nor more than one hundred private men, including farriers.

To each troop will be allowed.	If under 70 Rank and File.	If 70 Rank and File or upwards.
Captain	1	1
Lieutenants . . .	1	2
Cornet	1	1
Quartermaster . .	1	1

2. A squadron to consist of two troops.
 3. A corps to consist of three or four troops.

4. A regiment to consist of from five to twelve troops.

5. A corps of three or four troops may have one major.

6. A regiment of from five to seven troops, both inclusive, may have one lieutenant-colonel and one major.

7. A regiment of from eight to twelve troops both inclusive, may have one lieutenant-colonel commandant, one lieutenant-colonel, and one major.

8. One serjeant, (including the drill-serjeant), and one corporal, will be allowed to every twenty private men.

9. One trumpeter to each troop.

Staff.

10. An adjutant, surgeon, and serjeant-major may be allowed on the establishment of corps of not less than three troops; but neither the said staff officers nor any other officers or men, will have any pay or allowance whatever, except in the cases hereinafter mentioned.

HIS MAJESTY’S SECRETARY OF STATE.

11. His Majesty’s Secretary of State for the Home Department is the authority to whom all matters for consideration, for which the existing regulations do not provide, and which are not connected with the immediate issue of allowances, should be referred, through the medium of His Majesty’s Lieutenant of the county.

12. Returns of the effectives, in the annexed form, signed by the commandant, are to be transmitted direct to His Majesty’s Secretary of State, at three stated periods within the year, viz. on the 1st April, 1st August, and 1st December.

Return of the number of persons now enrolled and serving in the
 corps of _____ in the county of _____ commanded by
 1st of _____ 183

	Lieut.-Colonel.	Major.	Captains.	Lieutenants.	Cornets.	Adjutant.	Surgeon.	Ass. Surgeon.	Vet. Surgeon.	Quart.-Masters.	Serjt. Major.	Serjeants.	Corporals.	Trumpeters.	Ferriers.	Privates.	Total.
Number serving																	
Wanting to complete																	
Establishment																	

I hereby certify this to be a correct return,

Commandant.

N. B.—This is the form of return to be used in future by commandants in making returns of their corps to the Secretary of State, at the periods prescribed by the Volunteer Act, viz. 1st of April, 1st of August, and 1st of December in each year.

The returns are to be addressed,

“To His Majesty’s Principal Secretary of State,

Home Department.”

13. When troops or corps are formed into regiments, the returns for His Majesty’s Secretary of State are to be made up for the regiment, and not for the incorporated troops individually.

HIS MAJESTY’S LIEUTENANTS OF COUNTIES.

14. His Majesty’s Lieutenant of the county is the channel through which all matters for the consideration of His Majesty’s Secretary of State for the Home Department, or the Board of Ordnance, respecting volunteer corps, should be conveyed.

15. It is indispensable that His Majesty’s Lieutenant should be addressed on the following heads:—*

Alteration in the title or establishment of the corps.

Constant pay for an adjutant.

Permission to exercise for any number of days not exceeding fourteen, under 44th Geo. 3, cap. 54.

Permission to be placed on permanent duty.

Supply or exchange of arms and accoutrements.

Officers’ commissions.

16. His Majesty’s Lieutenant of the county, (or in his absence the Vice-Lieutenant or Deputy-Lieutenants executing

* These applications are to be submitted by His Majesty’s Lieutenant, if he approves thereof, to His Majesty’s Secretary of State, with the exception of those for arms, &c. which are to be referred to the Board of Ordnance, with a return of the effective strength of the corps.

the office of His Majesty’s Lieutenant,) upon receiving the proposal from the commandant of a corps for permission to exercise under the provisions of the 44th Geo. 3, cap. 54, sect. 46, &c. is to submit the same for His Majesty’s approbation, and having received from the Secretary of State a notification thereof, is to transmit to the Secretary-at-War a return of such corps, specifying the date, and place of assembly, the number of men, and number of days, not exceeding fourteen.

17. Commissions are to be signed by His Majesty’s Lieutenants;—the fee to the clerk upon each commission is not to exceed five shillings, which is the whole expense of the commission, the stamp duty not being chargeable thereon.

18. In order that the names of officers may be inserted in the Gazette, it is necessary that a list thereof, stating the dates of the commissions, and that they have been signed by His Majesty’s Lieutenant, should be transmitted, by the Clerk of the Peace, to the Gazette writer; the list to be signed by His Majesty’s Lieutenant, or the Clerk of the Peace for the county.

19. It is particularly desirable that every officer, as soon as he receives his commission, should take the necessary steps for having his appointment inserted in the Gazette.

ORDNANCE DEPARTMENT.

The following Articles are supplied in kind by the Board of Ordnance.

20. Carbines, and steel rammers, 12 to a troop.

Pistols, sabres, sabre belts and knots.

Trumpets, trumpet strings, or bugles with strings.

21. Ammunition.—For practice, is supplied half-yearly, upon the application of the commandant to the Board of Ordnance; when such application is made, the following information is to be given upon the face of the application, viz:—

The number and description of arms in possession.

The number of effective men for whom ammunition is required.

The number of cartridges in possession of the corps, unexpended from any previous supply.

The number of cartridges required to complete the regulated proportion, which proportion is to be calculated,—

Spring practice and exercise, due 25th March. Six rounds of ball-cartridges, sixteen ditto blank, three flints, per man.

Autumn practice and exercise, due 29th September. Four rounds of ball-cartridges, eight ditto blank, two flints per man.

Head Quarters, ———

22. Ammunition.—For actual service, the application is to be made to the general officer commanding in the district.

23. Commandants may purchase clothing and appointments from the public stores, if they are desirous of so doing. Applications on the subject are to be addressed to the Board of Ordnance.

WAR OFFICE.

24. The pay and allowances of the yeomanry cavalry are issued under the authority of the Secretary at War, and the applications or correspondences relative thereto should be addressed to him.

25. Letters or packets intended for the War Office are to be transmitted under cover, as follows:—

To

*The Secretary at War,
War Office.*

LONDON.

Yeomanry }
Cavalry. }

26. In replying to any letter from the War Office, care is to be taken to quote the number and date thereof.

U. S. JOURNAL. No. 31. JUNE 1831.

TROOP RETURNS.

27. Commandants of corps of yeomanry cavalry are required to furnish the Secretary-at-War, annually, with returns showing the duty or exercise which has been performed by the corps under their command.

28. The returns are to be completed and transmitted within one month after the receipt of the forms from the War-Office, or the cause of the delay must be explained.

CONSTANT PAY AND ALLOWANCES.

Serjeant-Major.

29. To a corps consisting of not less than three troops of forty private men each, constant pay at 5s. 2d. per diem, including 2s. for forage, will be allowed for a serjeant-major, if qualified by former service; the pay is to commence from the first period of his doing duty after the acceptance of the corps. A certificate of the serjeant-major's services, signed by the commandant, is to be annexed to the first application in which his pay is charged, and also a certificate that the man has been duly attested to serve in the corps.

30. *Qualifications.*—Three years' service as a non-commissioned officer in the regulars, embodied militia, or fencible forces.

Adjutant.

31. To a corps consisting of 300 rank and file, or upwards, constant pay at 8s. per diem, including 2s. for forage, may be allowed for an adjutant instead of a serjeant-major.

32. Constant pay for an adjutant, where properly qualified by former service (which must be distinctly specified in the recommendation,) is only allowed upon the special application of the Lord Lieutenant to the Secretary of State. The adjutant's pay is to commence from the first period of his doing duty after the acceptance of the corps.

33. *Qualifications.*—Four years' service as a commissioned officer, or serjeant-major in the regulars, embodied militia, fencibles, or East India Company's forces.

Allowance in Lieu of Contingencies, including Pay for Drill Serjeants and Trumpeters.

34. For each effective non-commissioned officer, trumpeter, and private man, not exceeding the establishment of the corps, exclusive of the serjeant-major, 1l. 10s. per annum.

T

Allowance for providing the Corps with Clothing and Appointments.

35. For each effective non-commissioned officer, trumpeter, and private man, not exceeding the establishment of the corps, including the serjeant-major, 1*l.* 10*s.* per annum.

36. The pay of the adjutant or serjeant-major, and the contingent and clothing allowances, are issued half-yearly in advance, and the commandant is to make application for them upon the form that will be transmitted to him from the War-Office, for that purpose.

37. The contingent and clothing allowances are issued for three years at once to new corps, or to augmentations of old corps, if required by the commandants, for such men as are certified to have been actually enrolled and provided with clothing and appointments, within two months after the date of the acceptance of the service of such new corps or augmentations. The requisite form will be supplied by the War-Office, upon application from the commandant.

38. When separate troops or corps are formed into a regiment, the commandant will receive all balances of the contingent and clothing allowances in the hands of the commanding officers of the corps or troops forming the regiment, and will draw for all arrears.

ALLOWANCES FOR EXERCISE.

Under the Act of 44th Geo. 3, cap. 54, sect. 46, 47, and 48.

39. Two shillings a day for each man, and 1*s.* 4*s.* a day for each horse, (but no other allowance whatever,) will be issued for the effective men and horses present at exercise, for a number of days not exceeding fourteen within the year; such exercise having been performed either consecutively or at intervals.

40. Application for authority to perform this service is to be made by the commandant to His Majesty's Lieutenant of the county (enclosing a return, showing the proposed date and place of assembly, the number of men, and of days of exercise, not exceeding fourteen), who is to apply to His Majesty's Secretary of State for the Home Department, for permission that the corps may exercise accordingly; and upon receiving from the Secretary of State a notification of His Majesty's approbation, His Majesty's Lieutenant will certify the return abovementioned, and transmit the same to the Secretary at War, whereupon forms of estimate and account will be supplied from the War-Office.

41. In ten days after the duty shall have been performed, the commandant will transmit to the Secretary at War an account specifying the sum received and the amount paid. The commandant will then be furnished with a form of bill to draw for any balance which may be due from the public, or with instructions to remit to the Bank of England any balance which may remain in his hands.

42. Particular care must be taken to distinguish between the two services upon which the cavalry are employed, namely, permanent duty, and exercise under the 46th section of the volunteer act, as the pay and allowances for each service are different.

PERMANENT DUTY.

43. Corps of yeomanry cavalry may be allowed, under the regulations herein mentioned, to assemble on permanent pay and duty, for a period not exceeding six successive days in the year, exclusive of the days of marching to and from the place of assembly, in lieu of going out for training and exercise, under the provisions of the 44 Geo. 3, c. 54.

44. Previously to the actual assembling of any corps on permanent duty, the time and place proposed for its assembly are to be submitted by the commandant to the Lord Lieutenant of the county,* by whom the same will be notified to the Secretary of State for the Home Department, in order that His Majesty's pleasure may be taken thereupon, and signified by such Secretary of State to the Lord Lieutenant; and no corps is to be actually assembled until the commandant shall have received from the Lord Lieutenant of the county a notification in writing, that His Majesty has been pleased to approve of the time and place proposed for the assembly of his corps.

45. Corps assembled upon this duty, where there is a general of the district, are to be under his command; or if assembled in a garrison, are to be under the command of the governor, or commandant thereof, for the time being; and they are in all respects diligently to conform to the rules, regulations, and ordinances of His Majesty's military service; and the commanding officer of the corps, as soon as he shall have received from the Lord Lieutenant of the county a notification of His Majesty's permission for the assembling of the corps, will transmit to the

* The application should be made one month at least prior to the date on which it is proposed to assemble the corps.

Secretary at War an estimate of the sum required, for the pay and allowances of the officers, non-commissioned officers, trumpeters, and private men, expected to be assembled, proper forms for which are supplied by the War-Office, and is to follow such directions as shall be communicated to him by that department, with respect to the payment, subsistence, and economy of the men so assembled.

46. Accounts are to be rendered to the Secretary at War immediately on the expiration of the duty.

47. The commanding officer is to cause the Articles of War to be read to his corps, as soon after its first assembling as may be practicable, and to repeat the same from time to time, in the manner practised in the militia and regular forces.

48. A schedule of the rates of pay and allowances is annexed.

DUTY-IN AID OF THE CIVIL POWER.

49. Corps or detachments of yeomanry cavalry, when called out in aid of the civil power, are entitled, for the period of such duty, to the pay and allowances granted for permanent duty.

50. The order of the lieutenantancy or magistrate should state the circumstances which have rendered it necessary to call for the services of the corps, and the number of troops that have been required to assemble.

51. When a corps of yeomanry cavalry has been required to assemble, the commandant is immediately to transmit to the War-Office the order of the lieutenantancy or magistrates, and to request to be furnished with forms of estimate and account, which will be forwarded to him without delay.

52. When the account is transmitted, it is to be accompanied by a certificate to the following effect:—

We, the undersigned magistrates for the _____ of _____ troops do hereby certify, that _____ of the _____ corps of yeomanry cavalry were assembled in aid of the civil power on the _____ and that the said troops were actually and necessarily required by the civil authorities to remain on duty from that date until the _____

} Magistrates for the _____ of _____ residing at _____

POINTS TO BE OBSERVED IN DRAWING AND NEGOTIATING BILLS UPON THE PAYMASTER-GENERAL.

53. When an estimate or account is approved, a form of bill for the sum which

the Paymaster-General may be authorised to issue, will be transmitted from the War-Office, to the proper officer for negotiation.

54. No officer is allowed to draw any bill upon the Paymaster-General, but upon the very form which he shall have received from the War-Office, with the exact sum to be drawn by him already inserted therein.

55. No bill must, under any circumstances, be signed by any other person than the officer who shall have been expressly authorised by the War-Office to draw the bill.

56. The printed letter of advice annexed to the authority, must be carefully filled up, signed by the drawer of the bill, and transmitted to the War-Office, by the post of the day on which it was negotiated.

57. The letter of advice must exactly agree with the bill, in the particulars of its date, the amount, and the names of the parties to whom it is made payable.

58. In filling up the bill, the name of the party or firm to whom it is payable must be accurately spelt; the amount in the body of the bill must be distinctly stated in words at length, and must exactly agree with the amount stated in figures in the margin; these points deserve particular attention, as inaccuracies, especially where the name or firm in the body of the bill differs from the endorsement, will prevent the payment by the Bank of England, although the bill be duly accepted by the Paymaster-General.

59. When bills are returned unpaid by the Bank of England, on account of irregularity, after having received the Paymaster-General's acceptance, they must on no account be destroyed, but the irregularity must be corrected, and the bill again presented for payment; as the Paymaster-General, having once given his acceptance on behalf of the public, cannot give it a second time for the same sum.

60. In the event of a bill being accidentally defaced prior to acceptance, no other can be substituted by the accountant, but application must be made to the War-Office for a new form, and the bill so defaced must be returned to that department.

61. As by a proper attention to the regulations and the foregoing memoranda, no officer need ever be exposed to the inconvenience of having his bills returned; any expense which may arise in cases where irregularity occurs, must be borne by the drawers.

C. W. WILLIAMS WYNN.
War-Office, 1st Jan. 1831.

SCHEDULE OF THE PAY AND ALLOWANCES OF THE YEOMANRY CAVALRY WHILE DOING PERMANENT DUTY.

PAY.	Rates of Consolidated Pay and Allowances, per Diem.			
	£.	s.	d.	
An Allowance of 2s. 6d. a Day per Troop, is also made to the Colonel, or to the Officer having a Commission as Commandant . . .	Colonel	1	12	10
	Lieutenant-Colonel	1	3	0
	Major	0	19	3
	Captain (including his Allowance of 2s. 2d. per diem)	0	16	0
During a Vacancy in the command of a Troop, 2s. 2d. a Day will be allowed for the repair of Arms and other Expenses, to which the allowance to the Captain is applicable	Lieutenant	0	0	0
	Gornet	0	8	0
These Rates only to be allowed in the whole, whether the Officers hold other Commissions or not	Adjutant, (including constant Pay and Allowances)	0	10	0
	Surgeon	0	11	4
	Assistant Surgeon	0	8	0
	Quarter Master	0	5	6
In lieu of every other Charge whatsoever	Serjeant Major, (including constant Pay and Allowances)	0	7	0
	Serjeant	0	7	0
	Corporal	0	7	0
	Trumpeter	0	7	0
	Private	0	7	0
Including the Allowance for Fariery	Allowance in lieu of Forage for each effective Officer's Horse, not exceeding the proportions for each Rank*	0	1	6 ³ / ₄

CONTINGENT ALLOWANCES.

To defray the expense of postage and stationery, and other charges incidental to making up the accounts, viz :—

	s.	d.
For a corps { 1 troop . . . per diem	1	0
consist- { 2 troops	1	1
ing of { 3 or 4 troops	1	7
For a regiment consisting of 5, 6, } or 7 troops	1	10
For a regiment consisting of 8 } troops or upwards	2	1

Divine Service.—No allowance is granted unless a separate service is absolutely requisite. In such cases the clergyman is to apply to the War-Office for remuneration.

Ferries.—The actual expense incurred in passing ferries, supported by the proper vouchers, will be allowed.

Medicines furnished to the Sick.—The actual expense thereof will be allowed, provided the charge made be previously approved by the Director-General of the Army Medical Department, Berkeley Street, London.

Compensation for Horses.—The value of the horse, not exceeding thirty pounds, will be granted to the owner thereof, upon the application of the commandant of the corps, provided the Secretary at War shall be satisfied that the loss was entirely and inevitably occasioned by the act of duty in the performance of which the horse was injured.

The application is to be accompanied by a detailed statement of the circumstances of the case, certified by the commandant, and by a certificate of the value of the horse.

* Proportion of Horses for each Rank :—

Field Officer	not exceeding 4	Surgeon	not exceeding 2
Captain	3	Assistant-Surgeon	1
Subaltern	2	Quarter-Master	1
Adjutant	3		

PROMOTIONS & APPOINTMENTS.

NAVY.

PROMOTIONS.

CAPTAINS—Thomas Wren Carter; Philip Broke.

COMMANDERS—W. Kelly, R. Palk (retired); E. Reyner (retired); A. Capel, — Timms (retired); Horatio T. Austin.

LIEUTENANTS—John M'Clintock; — Clive; J. H. Windon; E. Foley; B. West; R. T. Eyre; A. S. Hamond; Owen Stanley; Lord Clarence Paget.

SURGEON—G. Symes.

APPOINTMENTS.

CAPTAINS—Lord James Townshend, to the Dublin, vice Henry Hope; J. Clavel, to the Ordinary at Plymouth, vice Pilfold; P. Blackwood, to L'Aigle.

COMMANDERS—W. Richardson (b), to the Preventive Service; E. Blankley, to the Pilades; Alex. Ellice, to the Victor; T. Talbot, to the Phocis; Hon. F. J. J. De Roos, to the Algerine.

LIEUTENANTS—A. F. Parr, Second-Lieut. of Haslar Hospital, vice Marshall, app. Warden of Portsmouth Dock Yard, vice Derby, dec.; Thomas O. Knox, to the Royal George Yacht; J. Noble, to the Pallas, vice Butterfield; G. Goldfinch and J. Heysham, to the Pearl; W. Sturgess, from the Ordinary at Sheerness, to the Ordinary at Portsmouth; G. Wilson (a), to the Ordinary at Chatham; R. Coates, from the Ordinary at Portsmouth, to the Ordinary at Plymouth; F. Crozier and Lord F. J. Russel, to the Stag; G. Byng, and J. G. Crosbie, to the Rattlesnake; S. Marshall, to be Warden of Portsmouth Yard, vice Derby, dec.; A. Parr, to Haslar Hospital, vice Marshall; P. Ambrose, to the superintendence of the Semaphore at Portsmouth; R. Parrey, and H. O. Nolloth, to the Gallatea; W. M. J. G. Pascoe, and R. S. Robinson, to the Dublin; W. J. Williams, to the Seringsapatam; E. Norcott, to the Druid; E. Foley, to the Brisk; G. V. Hart, to the Victor; H. Blair, to the Pallas; R. B. Crawford, from the Donegal, to command the Charybdis; H. Henderson, of the Barham, to the Dublin; C. Edmonds, of the Talavera, to the Barham; C. Birkett, to the Talavera; J. R. Wilson to the Telegraph at Putney Heath, vice Eldridge; H. J. Codrington, to be Flag Lieut. to Vice-Admiral Sir Edward Codrington; J. V. Fletcher, to be Flag-Lieut. to Rear-Admiral W. Parker, C.B.; R. Yorke, to the Donegal. The following have been appointed to the Preventive Service on the Coast of Kent:—G. Drew, W. Beckett (b), H. Lawless, J. Kiddle, C. A. Johnston, G. Humphreys, H. S. Laston, J. Stephen, E. Nicholl, J. M. Bate, T. S. Hall, W. Whitfield, G. A. Leary, T. Ross, G. S. Baker, W. G. Pearne, C. F. Blissett, W. Squire, A. S. Wright, Zach. Mudge, J. Jeaves, C. Pockett, T. P. Wheeler, H. Batt, J. Duffill, T. A. Butler, J. M. Langtry, G. Gahan, R. Hunter, H. E. Wingrove, J. R. Benson, V. P. Hunter—all from the Talavera—S. Wilkinson, E. Jull, W. H. Dickman, C. W. Poynter, W. Seaward, W. Curlewis (Hyperion), J. Edwin, R. Morgan (b), W. Henslow, J. Knight, R. Edvain, G. Campbell, R. Pace, and J. Baker.

SURGEONS—A. Lane, to the Pearl; P. Suther,

to the Stag; R. Marshall, to the Rattlesnake; G. Symes, to the Jascour.

ASSISTANT-SURGEONS—G. Munro, to the Pearl; R. M'Lean (Super.), to the Rattlesnake; Nautley, to the Brisk; F. Cottam, to the Asia; W. Glasgow, to the Orestes; H. Williams, to the Asia; W. Watt, of the Curaçoa, to the Prince Regent; J. M'Kittrick, of the Wellesey, to the Curaçoa; J. Lambert, of the Asia, to the Wellesey; — Mould, and — Anderson, to the Warspite.

PURSEES—F. Lean, to the Pearl; — Richards, to the Ordinary at Portsmouth; — Green, to the Rattlesnake; W. Drake, to the Pylades; — South, to the Victor.

CHAPELLAINS—Rev. N. Royle, to the Pallas; Rev. C. H. Lethbridge, to the Prince Regent.

ROYAL MARINES.

PROMOTIONS.

CAPTAIN—John Evan Jones.

FIRST-LIEUTENANT—T. Hurdle.

APPOINTMENTS.

LIEUTENANT-COLONEL—Wingrove, is appointed Aide-de-Camp to the King.

FIRST-LIEUTENANT—W. Pearce, from the Portsmouth Division, to the Rattlesnake.

SECOND-LIEUTENANT—J. J. Buckhouse, to the Chatham Division.

ARMY.

DOWNING-STREET, APRIL 27.

The King has been pleased to appoint Major-Gen. Richard Bourke to be Capt.-Gen. and Governor-in-Chief of the Colonies of New South Wales and Van Dieman's Land, and their respective dependencies.

WAR OFFICE, APRIL 29.

3rd Regt. of Dr. Gds.—Lieut.-Gen. Samuel Hawker, to be Colonel, vice Gen. Sir William Payne, Bart. dec.

47th Regt. Foot.—Brevet-Major Fade Headley, to be Major, without p. vice O'Donoghue, prom.

Garrison.—Major-Gen. John Waters, to be Capt. of Yarmouth Castle, vice Lieut.-Gen. Hawker, app. to the command 3rd Dr. Gds.

Memorandum.—His Majesty has been pleased to command that the 3rd Regt. of Foot Gds. be styled "The Scotch Fusilier Guards."

WAR OFFICE, MAY 3.

4th Regt. Dr. Gds.—Cornet Lionel Place, to be Lieut. by p. vice FitzRoy, who ret.; Arthur Bastard Easterbrooke Houldsworth, gent. to be Cor. by p. vice Place.

13th Regt. Light Drs.—To be Lieuts. by p.—Cornet Thomas Garde Durdin, vice Wetherall, prom.; Cornet Robert Hackett, vice Ogilvie, prom.

To be Cornet, by p.—James Edward Bradshaw, gent. vice Hackett.

1st or Gren. Regt. Foot Gds.—Capt. Lord Charles Welleley, from the Rifle Brig. to be Lieut. and Capt. vice Hulse, who exc.

11th Regt. Foot.—Ens. Bertram Charles Miford, to be Lieut. by p. vice Fyers, who ret.; Alexander Browne, gent. to be Ens. by p. vice Miford.

12th Foot.—Capt. James Paterson, from h. p. to be Capt. vice Edward Hugh Hunt, who exc. rec. the diff.

22nd Ditto.—Hardress Waller, gent. to be Ens. by p. vice Flanagan, app. to the 76th Foot.

33rd Ditto.—David FitzGerald Longworth, gent. to be Ens. by p. vice Graham, prom.

40th Ditto.—John Judkin Morris, gent. to be Ens. without p. vice Wood, app. to the 48th Foot.

44th Ditto.—Ens. John Pennington, to be Lieut. without p. vice Scott, prom.; Ens. William George White, from 48th Foot, to be Ens. vice Pennington; Lieut. Alured William Gray, to be Adj. vice Scott, prom.

46th Ditto.—John Gore Ferns, gent. to be Ens. without p. vice Campbell, prom.

48th Ditto.—Ens. John Stewart Wood, from 40th Ft. to be Ens. vice White, app. to the 44th Ft.

57th Ditto.—Gent. Cadet Frederick Henry Worsley, from Rl. Mil. Col. to be Ens. by p. vice Tranter, prom.

66th Ditto.—Capt. Robert Brookes, to be Major, by p. vice Johns, who ret.; Lieut. Edward Bolton, to be Capt. by p. vice Brookes; Ens. George James Bernard Hankey, to be Lieut. by p. vice Bolton.

76th Ditto.—Ens. George Frederick Cooper Scott, to be Lieut. by p. vice Hildebrand, who ret.; Ens. John B. Flanagan, from 22nd Foot, to be Ens. vice Scott; Lieut. Samuel Blow Ross, to be Adj. vice Hildebrand, who res.

81st Ditto.—Capt. Robert Logan, from h. p. to be Capt. vice John Ogilvy, who exc. rec. the diff.

93rd Ditto.—Edmund George Nicolay, gent. to be Ens. by p. vice Jephson, who ret.

Rifle Brigade.—Lieut. and Capt. Charles Hulse, from 1st or Gren. Regt. Foot Gds. to be Capt. vice Lord Charles Wellesley, who exc.

Ceylon Regt.—Sec. Lieut. Simpson Nelson Burris, to be First-Lieut. by p. vice Delancey, prom.; R. E. Wilmot Horton, gent. to be Sec. Lieut. by p. vice Burris.

Unattached.—To be Capts. of Inf. by p.—Lieut. John Wetherall, from 18th Light Drs.; Lieut. Oliver Delancey, from Ceylon Regt.; Lieut. John Gilbert Ogilvie, from 13th Light Drs.

Memorandum.—The undermentioned officers have been allowed to retire from the service, by the sale of unattached companies:—Capt. Thomas Jones, h. p. unat.; Capt. Richard Despard, b. p. Nova Scotia Fenc.; Capt. Edward Favel Davis, h. p. 8th Foot.

Lieut.-Gen. Sir William Houstoun, G.C.B. to be Lieut.-Governor of Gibraltar, vice Gen. Sir George Don.

OFFICE OF ORDNANCE, MAY 5.

Rl. Regt. of Art.—First-Lieut. Lynch Talbot, to be Sec. Capt. vice Pattullo, dec; Sec.-Lieut. Alfred Tylee, to be First-Lieut. vice Talbot; Sec.-Lieut. Charles James Dalton, to be First-Lieut. vice Pickard, ret. on h. p.

WAR OFFICE, MAY 10.

4th Regt. Light Drs.—Cornet George Charles Dalbiac, to be Lieut. without p. vice M'Caffery, dec.; Cornet Matthew M'Donough, from Cavalry Depôt at Maidstone, to be Cornet, vice Dalbiac.

9th Ditto.—Cornet William Hankey, to be Lieut. by p. vice Rind, who ret.; James Nixon Macartney, gent. to be Cornet, by p. vice Hankey.

10th Regt. Light Drs.—Brevet Major Arthur Kennedy, from h. p. 18th Light Drs. to be Capt. vice Macdonell, dec.

17th Ditto.—Troop Serj.-Major William Hall, to be Quar.-mast. vice Nicholson, dec.

1st or Gren. Regt. Foot Gds.—Lieut.-Colonel Fleming Thomas Roberts, from h. p. of Roll's Regt. to be Capt. and Lieut.-Colonel, vice Charles Parker Ellis, who exc.

17th Regt. Foot.—Ass.-Surg. James Smith, from h. p. 29th Foot, to be Ass.-Surg. vice Fraser, dec.

33rd Ditto.—Lieut. John Williamson, to be Adj. vice Paterson, who res. the Adjutancy only.

37th Ditto.—Lieut. Robert Honyman, from 62nd Foot, to be Lieut. vice O'Callaghan, app. to 41st Foot.

40th Ditto.—Staff-Surg. John Ramsay, M.D. from h. p. to be Surg. vice William Jones, who ret. upon h. p.

45th Ditto.—Lieut. Henry Wemyss Magee, from 30th Foot, to be Lieut. vice Craik, app. to 70th Foot.

70th Ditto.—Lieut. John Hamilton Craik, from 45th Foot, to be Lieut. vice Roeke, whose app. has not taken place.

90th Ditto.—Lieut. William J. Owen, to be Adj. vice Mackenzie, who res. the Adjutancy only.

95th Ditto.—John M'Donald, gent. to be Ens. by p. vice Hull, who ret.

Rifle Brigade.—Capt. James Kerr Ross, from h. p. unat. to be Capt. vice Charles Hulse, who exc. Hosp. Staff.—Apothecary William Thompson, to be Ass.-Surg.

Garrison.—Lieut.-Gen. Hon. James Ramsay, to be Gov. of Carlisle, vice Major-Gen. Sir George Adam Wood, dec.

The King has been pleased to appoint the undermentioned officers to be Extra Aides-de-Camp to His Majesty, with the rank of Colonel in the Army:—

Lieut.-Colonel Archibald Campbell, 46th Foot; Brevet Lieut.-Colonel John Bell, h. p. Permanent Ass.-Quar.-mast.-Gen.; Brevet Lieut.-Colonel Samuel Benjamin Auchmuty, h. p. 8th Gar. Bat.; Brevet Lieut.-Colonel Thomas Lightfoot, h. p. 45th Foot; Lieut.-Colonel Alured Dodsworth Faunce, 4th Foot; Lieut.-Colonel George Brown, Rifle Brig.; Lieut.-Colonel Frederick FitzClarence, 7th Foot; Lieut.-Colonel George Prescott Wingrove, Rl. Mar.

Brevet.—Capt. Everard William Bouverie, of Rl. Horse Gds. to be Major in the Army.

Memoranda.—The name of the Cornet app. to the 4th Dr. Gds. on the 3rd inst. is Roldsworth, and not Houldsworth.

The Christian names of Lieut. Ker, of the 37th Foot, are Richard Hall.

ST. JAMES'S PALACE, MAY 11.

The King was this day pleased to confer the honour of Knighthood on Joseph Whatley, Esq. Groom of His Majesty's Bedchamber, Knight Commander of the Royal Hanoverian Guelphic Order.

WHITEHALL, MAY 12.

The King has been pleased to direct letters patent to be passed under the Great Seal, granting the dignities of Baron, Viscount, and Earl of the United Kingdom of Great Britain and Ireland,

unto George FitzClarence, Esq. Colonel in the Army, and the heirs male of his body lawfully begotten, by the names, styles, and titles of Baron Tewkesbury, Viscount FitzClarence, and Earl of Munster.

WAR-OFFICE, MAY 17.

4th Regt. Light Drs.—Phillip Blundell Nesbitt, gent. to be Cornet, by p. vice Anstey, who ret.

13th Ditto.—Ens. John Hamilton Gray, from 15th Foot, to be Cornet, by p. vice Durdin, prom.

1st or Gren. Regt. Foot Gds.—Lieut. and Capt. William Henry Barnard, to be Capt. and Lieut.-Col. by p. vice Roberts, who ret.; Ens. and Lieut. John Adrian Hope, to be Lieut. and Capt. by p. vice Barnard.

2nd Regt. Foot.—Lieut. Peter Grehan, from 2nd West India Regt. to be Lieut. vice Edward Lynch Daniell, who ret. upon h. p. 7th West India Regt.

6th Ditto.—Lieut. Charles Stuart Barker, from h. p. to be Lieut. vice William Harrison Hill, who exc.

15th Ditto.—John Hope Wingfield, gent. to be Ens. by p. vice Gray, app. to 13th Light Drs.

28th Ditto.—Walter Carmichael Hailes, gent. to be Ens. by p. vice Trelawney, who ret.

41st Ditto.—Capt. John Wetherall, from h. p. to be Capt. vice Allan Henry Maclean, who exc. rec. the diff.

47th Ditto.—Capt. John Sandes, to be Capt. without p. vice Heatley, prom.; Ens. William Wise, to be Lieut. by p. vice Sandes; John Cailand Stuart Mangin, gent. to be Ens. by p. vice Wise.

48th Ditto.—Capt. William Johnson Campbell, from h. p. 82nd Foot, to be Capt. vice Agnew, prom.

57th Ditto.—Ens. Frederick James Taggart Hutcheson, from 74th Foot, to be Lieut. by p. vice Patnam, who ret.

68th Ditto.—Capt. Robert Gregan Craufurd, from h. p. to be Capt. vice Peter Bernard, who exc. rec. the diff.

72nd Ditto.—Lieut.-Col. Thomas Francis Wade, from h. p. to be Lieut.-Col. vice Arbuthnot, app. to 90th Foot.

74th Ditto.—Gent. Cadet George Thomas Evans, from Rl. Mil. Col. to be Ens. by p. vice Hutchison, prom. in 57th Foot.

90th Ditto.—Lieut.-Col. Charles George James Arbuthnot, from 72nd Foot, to be Lieut.-Col. vice Lord George William Russell, who ret. upon h. p.

92nd Ditto.—Capt. John Gilbert Ogilvie, from h. p. to be Capt. vice John Routledge Majendie, who exc. rec. the diff.; Ens. Archibald Neil Campbell, to be Lieut. without p. vice Lofe, dec.

94th Ditto.—Staff-Ass.-Surg. William Henry Burrell, M.D. to be Ass.-Surg. vice Bulfeel, who exc.

1st West India Regt.—Volunteer Edward Stanton, from Rl. African Colonial Corps, to be Ens. without p. vice Rawstorne, whose app. has not taken place.

2nd Ditto.—Lieut. William Somersall Eve, from h. p. 7th West India Regt. to be Lieut. vice Grehan, app. to 2nd Foot.

Unattached.—Brevet Major James Agnew, from 48th Foot, to be Major of Inf. without p.

Hosp. Staff.—Ass.-Surg. Edward Josias Bulfeel,

from 94th Foot, to be Ass.-Surg. to the Forces, vice Burrell, who exc.

Memoranda.—The Christian names of Capt. Cowell, h. p. 71st Foot, are James Gifford.

The rank of Cornet M'Donough, of the 4th Light Drs. has been made permanent from the period of his appointment as Riding-master and Acting Adjutant at the Cavalry Dépôt, 6th of March 1826, but he has not been allowed any additional pay.

The name of the gentleman appointed to an Ensigny in the 42nd Foot, on the 26th of April 1831, is Stewart, and not Steward, as formerly stated.

DOWNING-STREET, MAY 19.

The King has been pleased to nominate and appoint Admiral Sir Henry Trollope, Knight Commander of the Most Honourable Military Order of the Bath, to be a Knight Grand Cross of the said Most Honourable Military Order, vice Vice-Admiral Sir William Johnstone Hope, dec.

His Majesty has been further pleased to nominate and appoint the following officers to be Knights Commanders of the said Most Honourable Military Order, viz.:

Vice-Admiral Edward Griffith Colpoys and Vice-Admiral Edward James Foote.

WHITEHALL, MAY 24.

The King has been pleased to grant to Frederick FitzClarence, Esq. a Colonel in the army; to Adolphus FitzClarence, Esq. a Captain in the navy; and to the Rev. Augustus FitzClarence, respectively, the title and precedence of the younger son of a Marquis of the United Kingdom of Great Britain and Ireland; and also has been pleased to grant to Sophia, wife of Sir Philip Sidney; to Mary, wife of Charles Richard Fox, Esq. a Lieut.-Colonel in the army; and to Augusta, widow of the Hon. John Kennedy Erskine, respectively, the title and precedence of the daughter of a Marquis of the said United Kingdom.

And also to command, that the said grant be registered in His Majesty's College of Arms.

WAR-OFFICE, MAY 24.

1st Regt. Life Gds.—Cornet and Sub-Lieut. Thomas Bulkeley, to be Lieut. by p. vice Every, who ret.; Lord Thomas Charles Pelham Clinton, to be Cornet and Sub-Lieut. by p. vice Bulkeley.

1st Regt. Drs.—Cornet Hon. William Rollo, to be Lieut. by p. vice Desborough, who ret.; George King Adlerson Molyneux, gent. to be Cornet by p. vice Rollo.

4th Regt. Light Drs.—Lieut. Edgar Gibson, to be Capt. by p. vice Spooner, who ret.

Colds. Regt. Foot Gds.—Duncan Macdonell Chisholm, gent. to be Ens. and Lieut. by p. vice Hugh Forbes, prom.

39th Regt. Foot.—Arthur Charles Morris, gent. to be Ens. without p. vice Stewart, app. to 61st Foot.

48th Ditto.—Capt. James Robertson, from h. p. to be Capt. vice Campbell, who ret.

61st Ditto.—Ens. John Hamilton Stewart, from 39th Foot, to be Ens. vice Liston, dec.

92nd Ditto.—Lord Walter Butler, to be Ens. by p. vice Campbell, prom.

Unattached.—To be Capt. by p.—Ens. and Lieut. Hugh Forbes, from Colds. Regt. Foot Gds,

ANNALS OF THE BRITISH ARMY.

1805.* War with France, Holland, and Spain.	Principal Staff at Head-Quarters.	Principal Commanders-in-Chief, and Governors abroad.
	Secretary-at-War.— Right Hon. Wil- liam Dundas. Captain-General and Commander-in- Chief, Field-Marshal H. R. H. the Duke of York, K.G. Adjutant-General.—Major-Gen. Harry Calvert. Quarter-Master-General.—Major-Gen. Robert Brownrigg. Master-General of the Ordnance.— John Earl of Chatham, K.G. Lieut.-General of the Ordnance.—Gen. Sir Thomas Trigge, K.B.	East Indies.— { Lieut.-Gen. Gerard Lord Lake. Canada.— { Lieut.-Gen. P. Hunter, died 21st Aug. 1805. Nova Scotia.— { Lieut.-Gen. Harry Bow- yer to 24th Sept. Gen. Wm. Gardiner. Jamaica.— { Lieut.-Gen. George Nu- gent. Windward and { Lieut.-Gen. Sir Wil- Leeward Islands.— { liam Myers, Bart. Major-Gen. Beck- with † from Aug. Lieut.-Gen. Harry Bowyer, appoint- ed 22nd Oct. Newfoundland.—Major-Gen. Skerrett. Mediterranean.— { Lieut.-Gen. Sir James Craig. Gibraltar.— Gen. Hon. H. E. Fox. Ceylon.— { Major-Gen. D. D. Wemyss, (succeeded by) Major-Gen. the Right Hon. Thomas Maitland.

DISTRIBUTION OF THE ARMY.		Numbers.
Guards, Garrisons, &c		138,091 †
Plantations		46,952
East Indies (four regiments of Dragoons, and fifteen regiments of Foot)		20,144
Troops and Companies for recruiting ditto		400
Embodied Militia and Fencible Infantry		84,386
Foreign Corps		17,286 §
		<hr/>
Deduct the Troops in the East Indies		307,420
		20,145
		<hr/>
	Total	287,275
ARMY ESTIMATES.		
Army, Ordinary		14,320,000
Ditto Extraordinaries		3,600,000
Ditto to make good excess of Extraordinaries beyond Estimates of } the preceding year		600,000
		<hr/>
		£18,520,000
	Ordnance	£4,457,000
RECRUITS RAISED DURING THIS YEAR, EXCLUSIVE OF FOREIGN AND COLONIAL CORPS.		
	Ordinary Recruits.	Additional Force.
1st half year	6,736	4,187
2nd half year	4,941	4,101
		Total.
		10,923
		9,042

MILITARY ACHIEVEMENTS AND OCCURRENCES, AND CHRONOLOGICAL
EVENTS OF THE ARMY.

January. After the fall of Deeg, || in the East Indies, Lord Lake's army moved to the siege of Bhourpoor. It was invested early in this month, and the siege was protracted to the beginning of

* For the year 1804, see page 425 of last volume.

† In temporary command, owing to the death of Sir William Myers, and until the arrival of his successor, Lieut.-Gen. Harry Bowyer in March 1806. In June 1808, Gen. Bowyer retired from the command of the army in the West Indies, and in October following Major-Gen. Beckwith was appointed to succeed him.

‡ Of this number were stationed in Ireland, Cavalry 6336, Infantry 34,106; together 40,442.

§ Expenditure £851,350.

|| See Annals 1804.

March, during which interval it was stormed four times unsuccessfully,* and with very considerable loss to the besiegers. Aggregate of our loss in killed and wounded before Bhurtpoor; 1 Lieutenant-Colonel, 2 Majors, 20 Captains, 1 Captain-Lieutenant, 45 Lieutenants, 1 Adjutant, 1 Cornet, 2 Ensigns, 1 Quarter-Master, 173 Petty Officers, and 782 Private Europeans; 294 Native Officers, and 882 Sepoys, &c. in all 2205 men. In the General Orders by the Commander-in-Chief, after the failure of one of the attempts made to carry the place by storm, he observes, "Notwithstanding the distinguished and persevering gallantry displayed by the troops in the assault of yesterday, and that the colours of the second battalion 12th Native regiment, were three times planted on the top of the bastion, the obstacles were such as not to be surmounted."[†]

February 21. In the House of Commons, Mr. Windham † (formerly Secretary at War) moved for a Committee to review the several acts passed in the two last sessions, for the defence of the country. The motion was lost by a considerable majority.—22. Dominica attacked by a French armament of one three-decker, and four other line-of-battle-ships, three frigates, two brigs of war, and a schooner. The Governor of the Island, Brig. Gen. Prevost, immediately made the best dispositions for its defence, and opposed, with the small force under his command, the landing of the enemy inch by inch. At length the whole of the enemy's force, consisting of above 4000 men, having effected a landing, and made such a disposition as threatened to cut off the retreat of the Governor and his few remaining troops from the town and fort of Prince Rupert, and thereby reduce the whole island, the Brig-Gen. with great promptitude and presence of mind, directed the regular force, under Capt. O'Connell, to make a forced march across the island and join him at Prince Rupert's, which place, attended only by his staff, he reached in twenty-four hours, and the troops arrived there with their wounded after four days' continued march through a most difficult country. The fort was immediately placed in the best state of defence, and the French Commander, after having in vain summoned § the Brig-

* Notwithstanding these failures, arising from the great population of Bhurtpoor, the natural difficulties of that extensive fortress, but principally from the extreme deficiency of the means which the besieging army possessed, the Rajah foresaw that the place must be ultimately taken, and accordingly early in March he sued for peace, which was granted by Lord Lake, on terms highly honourable to the English Government. Such was the paucity of our means and materiel at Bhurtpoor, that there were not above three or four mortars of any useful calibre; nor of battering guns above eight or ten at the beginning. Several of these ran at the vent from the effect of incessant firing, so as latterly to leave but few of them fit for service, and the dire expedient was resorted to of getting some of the battering guns taken from Holkar, breeched at Muttra, to patch up the miserably crippled and defective means of persevering in a siege which was deemed indispensably necessary for bringing the war to a conclusion.

† On this occasion, when a retreat was ordered, it was with great difficulty the men could be prevailed upon to withdraw; they yielded at length to the reiterated orders of their officers, after having repeatedly exclaimed "We must take the place or die here." Too fully was their determination verified, for in several of the corps employed, more than half their number were either killed or wounded.

‡ In the course of his speech he illustrated the inadequacy of the mixed and varied forces of the military system of the period. He said, that the volunteers looked like an army was very true, but still they were not an army. Nothing was more like a man than his picture, but the picture was not a man. The number of men who had entered by the circuitous routes of the army of reserve, afforded no proof whatever of its efficacy. It was a kind of turnpike where soldiers did not pay, but were paid for passing through it. The Army of Reserve Bill he compared to a great boiler or digester, with innumerable capillary tubes, running into every parish in the kingdom. It could no more raise men by means of the parish officers, than it could make a horse drink by taking him to the river. It was like harlequin's horse, which had but one fault, and that was, that he was dead. As to the manner in which our present military system might be remedied, he considered the military life a trade, and government the trader; as such it was the business of the trader to hold out all the inducements in his power to make his trade flourish. Men were found to go down and work in damp and unhealthy mines in Cornwall and Derbyshire, by giving them proper encouragement. A soldier, indeed, was not sure of a very long life, but his occupation was healthier than most others, and had great attractions for the young, ardent, and high-spirited. As to the officers, he thought their ranks, honours, and distinctions, should be confined exclusively to themselves, instead of being indiscriminately given to Militia, Volunteers, &c. Military distinction was of intrinsic value, because it implied intrinsic merit in the person who possessed it. He also recommended enlistment for a limited time, and an improvement in the pay and condition of the inferior officers, &c. &c.

§ Brig-Gen. Prevost replied to the summons "that his duty to his King and Country was so superior to every other consideration, that he had only to thank him for the observations he had been pleased to make on the often inevitable consequences of war." That the highest rank and command do not avert the shafts of misfortune, is evinced in the case of this officer, (the late Lieut-Gen. Sir George Prevost, Bart. Captain-General and Commander-in-Chief in North America, and Colonel of the 16th Foot.) From 1770 till 1814, with a small exception, he passed through an active service in the West Indies with distinction: in that interval, 1806 to 1808, he enjoyed the honourable appointment of Lieutenant-Governor of Portsmouth. He had received the highest honour that can be conferred on a British officer, the thanks of his country through its Parliament. Sir George died early in 1815, having, it is believed, suffered from the censures incurred by an unfortunate retreat. His Majesty,

general to surrender, thought proper, after levying a contribution upon the inhabitants of Roseau, which town had been set on fire in the moment of attack, and had suffered severely by the conflagration, on the 27th to re-embark his whole force, and after hovering a day or two in the bay, and about the port of Prince Rupert, made sail for Guadaloupe. At one period 200 of the British were opposed to more than 2000 of the enemy, and under the command of Major Nunn, who received a mortal wound, and subsequently under Capt. O'Connell, succeeded in withstanding them for more than two hours, and then effected their retreat, after having made much slaughter of the invaders. "British troops are not to be hostilely approached with impunity, and had not the town of Roseau been accidentally destroyed by fire, we should have little to regret, and much in which to exult."*—DISPATCH. The enemy's force, as stated above, exceeded 4000 men, the half of which was composed of the 26th Demi-brigade, one of the best in the French service. The rest were dismounted hussars and Piedmontese troops; the latter mostly very young men. To oppose them we had numerically 705 men,† of whom scarcely four hundred were actually engaged. The enemy acknowledged the loss of 500 men in killed and wounded; ours was small in comparison, 60;‡ and about 250, including the artillery, which was the only part of the regulars that fell into the enemy's hands, laid down their arms.§—24. Bommanganne, (or Balmengaon) East Indies, captured by a detachment under Capt. Hutchinsson.—28. Kurrawal, (or Kurrair) with a garrison of 2000 men, taken by 310 men, the storming-party led on in the most able and gallant manner by Lieut. Thomas Grant.¶ The detachment next proceeded against Darrarah (or Deyuopa), this fort was so covered by the glacis, that the commanding officer was under the necessity of fixing the breaching battery within fifteen yards of the counterscarp of the ditch, and the loss in the British lines was consequently severe. The breach being completed, the storming-party moved out at noon, under Lieut. Nugent, but were repulsed, owing to the difficulty of getting into the ditch, and being exposed to a galling fire from the fort. The garrison was now seen rushing to the outer gate, and it was apprehended they meant to take advantage of this critical moment and make a sally; but Lieut. Grant having skillfully managed, with the assistance of some artillerymen and golondanze, to

George the Fourth, (who was most watchful of the conduct and services of his officers) however, in care of his fame, conferred his posthumous honours on his family.

* The Patriotic Fund Committee at Lloyds voted to Brig.-Gen. Prevost, and the officers and men under his command, as a tribute of their consideration for the gallant defence of Dominica, as follows:—To Brig.-Gen. Prevost, a sword value £100, and a piece of plate value £200; to Major Nunn, a sword value £50, and a piece of plate value £100; a sword and a piece of plate of the same value to Capt. O'Connell; the sum of £100 to Capt. Campbell; and the sum of £40 to each disabled man, or who lost a limb; £20 to each man severely wounded; and £10 to every man slightly wounded.

† His Majesty's 46th Regiment, under Capt. James	250
1st West India Regiment, Major Nunn and Capt. O'Connell	70
Royal Artillery, Capt. Waller	15
St. George's Regiment of Militia, Colonel Beech	260
Independent Company, Capt. Serrant	60
Sailors at the guns	30

705

The regular officers engaged were, Royal Artillery, Capt. Waller; 46th Regiment, Capt. James, C. Campbell, wounded slightly, A. Campbell, and M'Dougall; Lieuts. Schaw, Nairn, Whyte, Thompson; 1st West India Regiment, Major Nunn, mortally wounded, Capt. O'Connell, slightly, and Lieut. Isley.

‡ They could have easily reached Prince Rupert's had the General given positive orders they should attempt it, but it appeared that he was desirous of having none but effective men in that garrison, being afraid of the provisions falling in case of a long siege; he therefore left it to their own option, having sent word to Colonel Beech that he would be glad to see as many of them as volunteered to encounter the hardships of a siege. Two companies under Capt. Armatrading and Beech immediately marched off with three cheers, the rest returning with the Colonel to Roseau.

§ For a Journal of the operations at Dominica, see Military Chronicle, vol. iv. 201, et seq.

¶ On the second day, when the breach was nearly completed, a flag of truce came out, and requested three days to surrender the fort; the answer given by the commanding officer was, that he would allow three hours, as he required that time to cool the guns; and the batteries ceased firing for that period, giving the enemy a shot occasionally, when any one appeared at the breach, so as to prevent their repairing it. The truce was afraid to return to the Killeddar with such an answer, and asked for protection in the British camp, which was granted. At eight o'clock at night, the storming-party, consisting of 200 men, moved on to the breach. It was agreed at their starting that the howitzer battery should serve the fort with shells until the storming-party gave three cheers from the works, and upon this signal of their having ascended the breach, the howitzers were to cease firing, and the commanding officer was to follow the storming-party with the rest of the detachment. When they arrived near the ditch some of the shells, owing to unskillful management in the elevation of the howitzers, fell short of the fort, and close to the storming-party, which produced considerable confusion; but Lieut. Grant having ordered the party to lie down and wait the burning out of the fuses, not a man was hit, every splinter went over them; he then ascended the breach, and carried the fort in gallant style. This service was particularly noticed by the Commander-in-Chief, Lord Lake, and by Gen. (afterwards Sir Richard) Jones, commanding the Bombay division of the army.

get a howitzer out of the battery, he planted it within ten yards of the gateway, where he served them with shells and grape, until he had made a favourable opening; and the slaughter between the two gateways far exceeded the enemy's loss in every other part of the fort; the storming-party rallied at the same moment and ascended the breach, and the enemy being between two fires, the fort, defended by a chosen set of brave men, within an hour was taken.*

March 2. Major-Gen. Smyth, with the cavalry of the Bengal army, attacked the Mahratta Chief Meer Khan, at Afzul Ghur; the two brigades were formed in two lines, the first line, consisting of the brigade composed of H. M.'s 24th and 25th Light Dragoons and a regiment of Native cavalry, was repulsed; the second line, consisting of the brigade composed of His Majesty's 8th Light Dragoons, and 3rd and 5th Native cavalry, under Colonel Vandeleur's † command, passed through the first, and defeated the enemy with great loss, the squadron of the 8th Light Dragoons, commanded by Capt. Dean, retaking the artillery which was in possession of the enemy. The Major-General afterwards joined Lord Lake's army before Bhurtpoor.—21. In the House of Commons, Mr. Pitt, as Chancellor of the Exchequer, introduced his plan for a direct reduction of the militia of England and Scotland to its original establishment of 40,000 for England and 8000 for Scotland, by allowing the supernumeraries above to volunteer into the line.—29. Lord Lake, Commander-in-Chief in India, with a column of cavalry under his personal command, and a column of infantry under Lieut.-Colonel Don, marched at two o'clock in the morning to surprise the cavalry of Jeswunt Rao Holkar, which was encamped at the distance of a few coss from Bhurtpoor. The apprehension of being surprised had induced the enemy to encamp in several separate divisions, and the operations of the British troops were directed against two of his principal encampments. His Lordship, with the cavalry, took a circuitous direction to the right under the hills; whilst Lieut.-Colonel Don, with the infantry, proceeded to the left, by the direct road to the position of the enemy, who having received information from his hircarrats of the approach of the British, was prepared for flight when Lord Lake reached his camp. In his retreat the enemy, however, suffered some loss from the fire of the column of infantry; and notwithstanding the rapidity of his flight, a charge was effected by the British cavalry, in which about 200 of the enemy were destroyed, and much baggage captured. Lord Lake, after continuing the pursuit to a considerable distance, returned to camp at eleven o'clock on the same morning.

April 1. Lord Lake having received intelligence that Jeswunt Rao Holkar had retired to a great distance from the British army, and assembled the greater part of his troops and baggage at a position eight coss from Bhurtpoor, in the direction of Futteypoor, determined, in expectation that the vigilance of the enemy would be diminished in consequence of the distance to which he had removed, to attempt to surprise his camp. His Lordship accordingly marched at one o'clock on the morning of the 2nd, with the whole of the cavalry, the horse artillery, and the reserve of the army, and arrived in the neighbourhood of the enemy's camp before dawn. Holkar, however, had received intelligence of Lord Lake's approach about two hours before his Lordship had reached the vicinity of his camp, and had sent off a part of his baggage. The enemy was posted round a high village, with his front covered by cultivated fields, surrounded by high inclosures. It was still dark, but the fires of the enemy enabled Lord Lake to make his disposition for the attack without waiting for daylight. The cavalry formed in two lines, moved round to the right, whilst the reserve and the horse artillery, under Lieut.-Colonel Don, was ordered to gain the left of the village with as much expedition as possible. The cavalry advanced at a trot, and when arrived within a short distance of the enemy, the right squadrons of each regiment in the first line were ordered to charge, supported by the remaining squadrons and the second line. The enemy on seeing the advance of the British made every possible exertion to escape, but was charged with success in various directions and suffered great loss. The British cavalry continued the pursuit to a very considerable distance, and did not desist until the enemy were entirely dispersed with a loss of upwards of 1000 men. Upon the return of Lord Lake to camp, a body of infantry with colours was observed moving in the direction of the jungle surrounding the town of Bhurtpoor. It was immediately charged by a squadron of His Majesty's 8th Dragoons, under Colonel Vandeleur, and after a few of the enemy had been cut down, the remainder threw down their arms, and were made prisoners.—11. A Treaty of Concert concluded at St. Petersburg between Great Britain and Russia, in which the two Governments agreed to adopt the most efficacious means for forming a league of the states of Europe to be directed against the power of France. Austria and Sweden soon after became parties to the league.

May 16. Commissioners ‡ appointed to inquire into all the abuses existing in the Military Departments.

November. A corps of 14,000 men, under Lieut.-Gen. Don, sent to the Continent to effect the evacuation of His Majesty's German States, and to undertake their defence against the enemy.

December. Towards the close of this year, Lord Lake, the Commander-in-Chief in India, again moved in pursuit of Holkar, who, having rallied a force during the rainy season, penetrated by the Dehly frontier, and passed the Sndldje into the Punjaub. Thither he was speedily followed by Lord

* The effect of this storm of a fort, said to be the strongest in that part of the country, was, that none of the other forts held out against the British, and they were left in quiet possession of the country for considerable distance around them.

† Now Lieut.-Gen. Sir John Ormsby Vandeleur, K.C.B.

‡ The individuals selected for this commission were, for the military details, Sir Charles Stuart, Major-Gen. Oakes, and Colonel Beckwith, (see obituary); for the civil economy, Lieut. Colonel Drinkwater; for the legal part, Mr. Cox and Mr. Cumming; and the mercantile judgment, Mr. Peters and Mr. C. Bosanquet.

§ This force returned to England in February 1806.

Lake, and after a very pleasant march, and the enjoyment of a fine renovating country, the British army of India was encamped at Christmas on the banks of the Hyphasis, where Alexander formerly terminated his march towards India, and where a treaty of peace having been concluded with Holkar, under the dictates of political, not military necessity, the operations of the war finally terminated, and the troops returned to the dominions of the East India Company.

OBITUARY, 1805.

February. Major Nunn.*
 March 1st. At his house in Hill Street, Berkeley Square, aged 81, Gen. Pattison, Colonel Commanding Royal Artillery.
 March. General Lord George Henry Lennox, Colonel 25th Foot.
 July. At Taunton, Colonel Trollope,† Royal Marines.
 August. Lieut.-Gen. Sir William Myers, Commanding the Forces in the Windward and Leeward Islands.
 August 7th. At Landguard Fort, Capt. Law.‡
 August 21st. Lieut.-Gen. Peter Hunter, Commanding in Canada.
 August 25th. Field Marshal His Royal Highness the Duke of Gloucester,§ K.G. Colonel of the 1st Foot Guards.
 October 4th. General Rooke, Colonel of the 35th Foot.
 October 5th. The Marquis of Cornwallis,|| Governor General of India, aged 67.
 October 14th. Brig.-Gen. Beckwith, one of the Commissioners for Military Inquiry.
 October 25th. Sir James Malcolm, Bart. late Lieutenant-Governor of Sheerness.
 December 26th. Gen. Mathew, Colonel of the 82nd Foot, aged 78.
 General Marquis of Lansdown, K.G. General Sir Hector Munro, K.B. Colonel 42nd Foot.
 Lieut.-Gen. Duncan Drummond, Colonel-Commandant, Royal Artillery. Lieut.-Gen. A. D'Aubant, Colonel-Commandant, Royal Engineers.

* See Annals—Attack of Dominica.

† He was the brother of the gallant Sir Henry Trollope. The Colonel, at the time when the spirit of mutiny caused such a commotion in our fleets, behaved with most manly courage and admirable presence of mind. When the flame was about to burst out in the ship he was on board of, as commanding officer of the Marines, he went singly into the midst of the mutineers, seized the two ringleaders by the collar, and had them put in irons in presence of their companions.

‡ He was an old and distinguished officer; he had served under Generals Wolfe, Monckton, and Townshend, in America, and acted with reputation as assistant engineer at Belleisle and Martinique. At the memorable assault at Quebec, he headed the gallant party of volunteers which attacked and repulsed Gen. Montgomery; and in Gen. Carleton's dispatch he was particularly and honourably mentioned. His merit alone recommended him to Lord Cornwallis, who, in 1795, appointed him store-keeper at Landguard Fort.

§ His Royal Highness never appeared as a public character; he at all times avoided any interference in the intrigues of parties, or in the agitation of political topics.

|| It justly belongs to our annals to record here the inscription on the monument raised to the noble Marquis, particularly as it states generally his career.

"Sacred to the Memory of Charles Marquis Cornwallis,
 Knight of the Most Noble Order of the Garter,
 General in His Majesty's army,
 Governor-General and Commander-in-Chief in India, &c.
 His first Administration

commencing in Sept. 1786, and terminating in Oct. 1793, was not less distinguished by the successful operations of war, and by the forbearance and moderation with which he dictated the terms of peace, than by the just and liberal principles which marked his internal government.

"He regulated the remuneration of the servants of the state on a scale calculated to insure the purity of their conduct. He laid the foundation of a system of revenue, which, while it limited and defined the claims of government, was intended to confirm hereditary rights to the proprietors, and to give security to the cultivators of the soil.

"He framed a system of judication, which restrained within strict bounds the power of public functionaries, and extended to the population of India the effective protection of laws adapted to their usages, and promulgated in their own languages.

"Invited in Dec. 1804 to resume the important station, he did not hesitate, though in advanced age, to obey the call of his country. During the short term of his last administration, he was occupied in forming a plan for the pacification of India, which, having the sanction of his high authority, was carried into effect by his successor.

"He died near this spot,* where his remains are deposited, on the 5th day of October 1805, in the 67th year of his age.†

"This monument, erected by the British inhabitants of Calcutta, attests their sense of those virtues which will live in the remembrance of grateful millions, long after this memorial of them shall have mouldered into dust."

* Ghazepore, Benares District.

† Born December 31st, 1735.

BIRTHS, MARRIAGES, AND DEATHS.

BIRTHS.

At Gibraltar, the Lady of Major Crawford, R.A. of a daughter.

At Avranches, the Lady of Capt. R. Saumerz, R. N. of a son.

The Lady of Capt. Gilburn, R. M. of a son.

At Exeter, the Lady of Capt. Cardew, Royal Invalid Engineers, of a daughter.

April 22nd. At Anne's Grove, the Lady of Lieut.-Gen. the Hon. Arthur Grove Annesley, of a son.

April 25th. At Doonass House, County Limerick, the seat of her father, Sir Hugh Dillon Massy, Bart. the Lady of Capt. Felix V. Smith, 2nd Queen's Bays, of a daughter.

At Limerick, the Lady of the late Alfred Wilson Trevelyan, Esq. late of the 32nd Regiment, of a son and heir.

At Manchester, the Lady of Lieut. H. R. Addison, Queen's Bays, of a son.

At Limerick, the Lady of Major M^cQueen, 74th Regiment, of a son.

At Oaklands, the Lady of Capt. Richardson, (late of the 1st Life Guards,) of a daughter.

At Cheltenham, the Lady of Capt. Macan, of the 16th Lancers, of a son.

April 27th. At Limerick, the Lady of Lieut. Grey, 58th Regiment, of a son.

At Cottage, Cavan, the Lady of Lieut. R. J. Stotherd, of the Royal Engineers, of a daughter.

May 9th. At Portsmouth, the Lady of Capt. Travers, Barrack-Master of that Garrison, of a son.

May 10th. In Limerick, the Lady of Lieut. Thomas Lewis, late of the 14th Regiment, of a son.

May 13th. At Chatham, the Lady of Major Wolrige, R. M. of a son.

May 21st. The Lady of Capt. Thomas Moore, R. M. of a son.

MARRIED.

At Trinity Church, St. Marylebone, W. Millingham, Esq. late Captain in the 2nd Regiment of Life Guards, to Caroline, third daughter of Sir C. Des Vaux, Bart.

April 4th. At St. Pancras Church, New Road, by the Rev. E. P. Hannam, Lieut. J. W. Dunbar Moodie, H. P. 21st Fusiliers; son of the late James Moodie, Esq. of Melsetter, in Orkney, to Susanna, youngest daughter of the late Thomas Strickland, Esq. of Reydon, in the county of Suffolk.

April 23rd. At St. James's Church, Piccadilly, Lieut.-Colonel the Hon. Leicester Fitzgerald Stanhope, third son of the late Earl of Harrington, and brother to the present Peer, to Elizabeth Williams, only child and heiress of the late William Green, Esq. of Jamaica.

At St. Peter's Church, Dublin, by special licence, Capt. James Gordon, late of the 4th, or King's Own Regiment, son to the late Lieut.-Gen. Gordon, of Cuming Skene, Pitburg, and Park Hill, Aberdeenshire, to Jane Adelaide, daughter of Alderman Thomas M^cKenny, of Fitzwilliam-street.

April 28th. At Bathwick Church, Commander W. H. Baptist Proby, R. N. to Louisa Mary, only daughter of the late Rev. Samuel How, of Suckland, Dorset, and Southleigh, Devon.

April 28th. At Stoke Church, Thomas B. Shipard, Esq. Purser, R. N. to Eliza, eldest daughter of Thomas Jeely, Esq. of Stoke Terrace.

At Coventry, Lieut. John Netterville Barron, of the 69th Regiment, to Emma, second daughter of the late Charles Watkins, Esq. Banker.

At Learnington Priors, Lieut. William Tringham, R. N. to Eleanor, widow of Lieut.-Colonel Henry Tarleton, late of the 60th Regiment.

At Watlingbury, Kent, Major Maclean, of the 81st Regiment, eldest son of Lieut.-Gen. Sir Fitzroy Maclean, Bart. to Emily Eleanor, fourth daughter of the Hon. and Rev. Dr. Marsham.

May 18th. At Cork, Lieut. Frederick Adolphus Robinson, 5th Regiment, son of the late Colonel, and nephew to Lieut.-Gen. Sir F. P. Robinson, to Eliza, eldest daughter of the late William Johnson, Esq. of Kiltwhelan, in the county of Cork.

DEATHS.

Jan. 28th. 1831. At East Malling, Colonel Syms, h. p. 80th Foot.

CAPTAINS.

Edwards, 46th Foot.

June 11th, 1830. At Persia, Hart, h. p. 65th Foot.

Jan. 9th, 1831. At Cork, Hyde, h. p. 82nd Foot. Stone, h. p. York Hussars.

LIEUTENANTS.

August 2nd, 1830. At Fort William, Bengal, Dwyer, 16th Foot.

Nov. 11th. At Berhampore, Bengal, Sparks, R. T. 46th Foot.

Feb. 27th, 1831. At Baldock, Cooch, h. p. 17th Foot.

March. O'Halloran, h. p. 22nd Foot.

March 25th. At North Leith, M^cIntosh, late 3rd Royal Veteran Battalion.

March 28th. M^cCouchy, h. p. 98th Foot.

At Godmanchester, Mason, late 2nd Royal Veteran Battalion.

April 6th. At Cork, M^cCaffry, 4th Dragoons.

ENSIGNS.

May 27th, 1829. At Tewkesbury, Martin, late 1st Royal Veteran Battalion.

October 30th, 1830. Crompton, 2nd West India Regiment.

March 23rd, 1831. At Jersey, Conolly, late 6th Royal Veteran Battalion.

February 11th. At Corfu, Quarter-Master Stewart, 88th Foot.

SURGEONS.

Drumgold, h. p. 10th Royal Veteran Battalion. January 13th. At Celle, Ziermann, h. p. 8th Line Battalion, King's German Legion.

April 12th, 1821. At Edinburgh, Assistant Surgeon Fraser, 17th Foot.

February 24th, 1831. At Malta, Assistant-Commissary-General Cundell.

April 9th. At London, Deputy-Commissary-General Dance.

April 23rd. At Stirling, Barrack-Master Forbes.

Dec. 27th, 1830. At Cannonnore, East Indies, in the 23rd year of his age, Ensign Edward Wheatstone, 54th Regiment, second son of Major Wheatstone, late of the 53rd Regiment.

Jan. 10th, 1831. At sea, on board the *Lady Macnaughton*, while on the voyage from Madras to England, for the recovery of his health, Assistant-Surgeon Dr. Alexander Urquhart, 46th Regiment, aged 28 years.

Feb. 5th. - Commander Henry Foster, R.N. of H. M. S. *Chanticleer*. It is with no ordinary feelings of regret that we have to record the loss of this meritorious officer. The unfortunate accident by which the Naval service has been deprived of an efficient and valuable officer, science of a gifted and devoted follower, and the officers and crew of the *Chanticleer* of a highly esteemed commander, appears to have occurred in the following manner. Having ascended the river Chagres, on his way to Panama, in a canoe of the country, from its being better adapted for such navigation, and succeeded in obtaining the necessary observations at this place, he re-embarked at Cruces on his return to the *Chanticleer*. In passing down one of the rapids, the awning of the canoe to which he had incautiously trusted, for the purpose of seeing a-head of her, gave way, and precipitated him into the river. Being unable to swim, he immediately sunk to rise no more. An officer who was in the boat, and one of the crew, instantly plunged after him, but in vain: the rapidity of the stream had carried him away, and it was with difficulty that they regained the canoe. His corpse was discovered by some Indians a few days afterwards, and conveyed to his officers, by whom it was interred at Chagres.—Much as the friends of Capt. Foster must deplore his loss, the hopes and expectations of scientific men will be no less disappointed. The celebrity he had gained among them by his indefatigable labours in the Arctic voyages with Sir Edward Parry, was an early promise of those valuable services to his country which he had so auspiciously commenced in the *Chanticleer*. The establishment of meridians, or, in other words, the correct measurement of the difference of longitude between the various places he had visited, is perhaps the greatest benefit which can at present be bestowed on navigation. Having extended his observations across the Isthmus of Darien to the shores of the Pacific, he had formed a connecting link in the grand chain of those observations, from which it would have been comparatively easy to carry them round the world. This object, we believe, was contemplated when the present voyage was commenced; and although, unhappily, he has not lived to execute such a magnificent undertaking, we hope not to see it abandoned. Thus has one of the noblest efforts of Government for the promotion of science been, in some measure, defeated. For, although we are far from believing that sufficiently-talented officers could not be selected from the Navy List to conduct the operations with which Capt. Foster was entrusted, it is but justice to his merits to say, that none could do so with more efficiency, zeal, or perseverance. By that zeal and perseverance in scientific pursuits, he had attained a proud distinction in the naval service, and had risen to a station among men of science far beyond his years within a comparatively short period. It must ever be regretted that he had not been spared to follow up the bright career which he had so successfully begun, and that by one incau-

tions step, he should have fallen ere he had completed his task and reaped its full reward. In the Fort of St. Lorenzo, at Chagres, situated at the mouth of the river, a tablet has been placed, with the permission of the Governor, in which is inserted a copper-plate, with the following inscription engraved on it:—

“This Tablet is erected by the late Senior Lieutenant and Officers of H. B. M. sloop *Chanticleer*, to perpetuate the memory of their late Commander Henry Foster, F.R.S. who was drowned in the river Chagres, on the 6th of Feb. 1831, while measuring the difference of longitude between Panama and Chagres. This talented and distinguished officer was employed in Nautical and Astronomical Science; having nearly completed his mission of three years' duration. He fell at his post—ripe in honours, but young in years. *Ætat* 36.”

Feb. 17th. At Trinidad, Lieut. J. B. Gullifer, R.N.

March 8th. At St. Lucie, Major-Gen. George Mackie, C.B. Governor of that Colony. He entered the army in 1794, and served in the expedition to the West Indies under Sir Ralph Abercrombie, and was at the attack of the Vigie, St. Vincent's, 10th June 1796. He also served in Grenada the whole of the Brigand War. In 1802, he returned to England on account of ill health, and in 1805 again proceeded to the West Indies. In 1807 he again came to England, and the following year returned to the West Indies. He was at the siege and surrender of Fort Dessay, at the capture of Martinique, and in other important services. His regimental commissions were in the 60th Foot and West India Corps.

April 8th. Near Dublin, Commander William Cobbe, R.N. aged 40. (1814.)

April 22nd. Major-Gen. Sir George Adam Wood, of the Royal Artillery, Governor of Carlisle. In Wexford, Capt. Kelly, late of the 54th Regiment.

In London, Capt. T. C. Watson, late of the 3rd King's Own Light Dragoons.

April 24th. Lieut. W. H. Blount, R.N. aged 40, only son of Sir Charles Blount.

April 27th. At Hollybrook, near Killybegs, in the 40th year of his age, Lieut. Weiss, R.N. Inspecting-Commander of the Coast Guard for the last ten years. The life of this excellent and lamented officer fell a premature sacrifice to the harassing fatigues and anxieties undergone while searching out and defeating a deeply-organized plan of smuggling, which was in full operation along the north-west coast of Donegal when he was appointed to the district. Lieut. Weiss has left a wife and eight children to deplore his loss.

April 29th. In Craven street, Strand, Rear-Admiral George Sayer, C.B. a Memoir of whose services appears in our present Number.

April 29th. At the Royal Naval Hospital, Portsmouth, Commander J. K. Kinsman, R. N. (1813.)

April 30th. In Lower Connaught-place, in his 76th year, Brig. Gen. Sir Samuel Bentham, K.S.G. late Inspector of Naval Works, and Civil Architect and Engineer of the Navy.

May 1st. At Rivoli, on his way to Florence, Commander Thomas Bury, R.N.

May 2nd. At Bath, after a long illness, Vice-

Admiral the Right Hon. Sir William Johnstone Hope, G.C.B. A Memoir will be found in our present Number.

At Speenhamland, Berkshire, Lieut. R. Cruise, R.N. in the 44th year of his age.

May 4th. At her house in Harley-street, Viscountess Nelson, Duchess of Brontë, widow of the immortal Nelson. Her remains were removed from the above residence on the 9th, for interment in the family vault at Littleham, near Exmouth, followed by Lord Bridport, Gen. Egerton, and other relations and friends of the deceased. A long line of carriages also attended, including those of Lords Nelson and Vernon, and Sir Thomas Hardy.

May 5th. Drowned in consequence of the upsetting of a yacht in Stoke's Bay, near Portsmouth, Admiral Sir Joseph Yorke, K.C.B. for whose Biography, &c. see page 215 of our present Number. On the same occasion, Captain Mathew Barton Bradby, R.N. and Capt. Thomas Young, R.N. met with a similar fate.

May 13th. At Shannon bridge, in his 26th year, after a few hours illness, Lieut. Richard Fitzgerald, 68th Light Infantry.

May 15th. At Haslar Hospital, Mr. R. D. Mosbery, Purser, R.N.

At Malta, Capt. George Mathew Jones, R.N. This very able officer commenced his naval services under the late Sir Joseph Sydney Yorke, and distinguished himself under the command of his friend Sir William Hoste, during his brilliant services up the Mediterranean. At the peace, Capt. Jones travelled through Holland, Denmark, Prussia, Norway, Russia, Turkey and Italy, and he published the result of his labours in two large volumes, which evince indefatigable research, acute sagacity, and a fine tact in estimating every thing which his industry brought under his cognizance. Capt. Jones received the greatest attention from the late and the present Emperors of Russia, and the Empress Mother. Shortly after his travels, this enlightened gentleman and able officer was suddenly affected by a paralysis of the limbs, and was obliged to repair to the South of Europe for the recovery of his health. In a very debilitated state he had the misfortune to fall down one of the precipitous flights of stone-steps at Malta, and broke three of his ribs, and dislocated his shoulder. He expired on the third day, after enduring great suffering. By this accident, the naval service has lost a brave, skilful and zealous officer—a gentleman of enlightened mind, and whose kind and friendly nature, and honourable conduct, had endeared him to his brother officers, as well as to a very numerous circle of private friends. Capt. Jones was brother to Colonel J. T. Jones, of the Royal Engineers, the constructor of the lines of Torres Vedras, and the officer who led our troops at the attack upon Bergen-op-Zoom.

The late Lieut.-General Sir William Payne Galway, Bart. Colonel of the 3rd Dragoon Guards, was appointed Lieutenant in the 1st Dragoons the 14th of July 1777, and Captain in 1782. He served in Flanders, and was in the principal actions in which the British were engaged. In 1794

he obtained a Majority and a Lieut.-Colonelcy in his regiment, from which he was removed to the 3rd Dragoons in 1796, and from thence to the 10th Light Dragoons in 1805. In 1793 he obtained the rank of Colonel, and was employed in the Staff of Ireland, as Brigadier-General, for three years, and as Major-General (to which rank he was appointed in 1805) for one year. In 1807 he obtained the Colonelcy of the 23rd Light Dragoons, and in 1811 received the rank of Lieut.-General. He served in Spain and Portugal, and was present at the affairs of Albergaria Nova, and Grijon, on the advance of the British army to Oporto, the 9th and 10th of May 1809; at the capture of Oporto the 11th of May; at the affair of Salamonde the 15th of May, and the pursuit of the French into Galicia; at the battle of Talavera, and in several of the subsequent operations of the army in the Peninsula. In 1814 he was removed to the 10th Dragoons, in 1815 to the 12th Dragoons, and in 1825 to the 3rd Dragoon Guards.

The late Lieut.-Gen. Lord Walsingham, (whose demise was recorded in our last number, and who was burnt to death at his house in Harley Street, on the 26th April last) entered the army in the year 1794 as a Cornet in the 1st Dragoons, and obtained a Lieutenantcy in the same regiment. He received a troop in the 25th Light Dragoons on that corps being raised, and succeeded to a Majority. He was appointed Lieut.-Colonel in the 1st Dragoons the 6th of June 1799, and this appointment he held at the time of his most melancholy death. The 25th April 1808, he became Aide-de-Camp to his Majesty George the Third, with the rank of Colonel in the army; Major-General 4th June 1811; and Lieutenant-General the 19th July 1821. In 1796 (then Major the Hon. George De Grey) he accompanied the 25th Light Dragoons to India; was landed with it on the passage out at the Cape of Good Hope, and did duty there during the arrival and taking of the Dutch fleet in Saldana Bay. He afterwards proceeded to Madras, and remained on that station until his return to England in 1806. He served with the cavalry of Gen. (afterwards Lord) Harris's army during the campaign of 1799, which ended in the capture of Seringapatam. He was present with his regiment at the battle of Mallavally. On the breaking out of the war in 1803, he was appointed to the staff of the home district, as Assistant-Adjutant-General, and was employed in that situation till the beginning of 1805, when he returned to the command of the 1st Dragoons, and did duty with the regiment from 1806 to 1808 in Scotland and Ireland. He accompanied his corps to Lisbon in August 1809, and served with the cavalry in the Peninsula until the beginning of 1812, when he was compelled by ill-health to return to England. He had been appointed in the beginning of 1810 to the command of the brigade consisting of the 3rd Dragoon Guards and 4th Dragoons; he was present at the battle of Busaco, the battle of Albuera, and at the affair of Usagre. On his return home he was placed on the staff at Canterbury, where he continued till the peace in 1814. He succeeded to the peerage on the death of his father.

METEOROLOGICAL REGISTER,

KEPT AT THE OBSERVATORY OF CAPT. W. H. SMYTH, AT BEDFORD.

APR. 1831.	Six's Thermometer.		At 3 P. M.			Pluvia- meter Inches.	Evapora- tor Inches.	Winds at 3 P.M.	
	Maxim. Degrees.	Minim. Degrees.	Barom. Inches.	Thermo. Degrees.	Hygrom. Parts.				
Q	1	48.3	42.4	30.34	47.8	544	—	-100	N.W. to N.E. blowing hard.
h	2	47.8	41.4	30.05	46.5	600	-190	-076	N.N.E. still blowing fresh.
Q	3	49.3	42.1	29.92	47.5	587	—	-090	N.N.E. blowing hard, fine.
Q	4	50.8	43.6	29.92	48.6	603	—	-080	E.N.E. fresh breeze, cloudy.
Q	5	51.3	49.5	29.93	48.8	625	-040	-100	S.S.E. fresh winds, cloudy.
Q	6	53.3	43.8	29.50	49.7	593	—	-099	E.S.E. blowing hard squalls.
h	7	54.2	46.0	29.49	50.3	680	-040	-080	E. fresh breeze and squally.
Q	8	53.8	40.3	29.50	52.7	610	—	-090	E.S.E. fresh breeze.
Q	9	55.0	48.8	29.65	55.0	561	-127	-100	S. by E. sky clearing.
Q	10	56.5	49.3	29.72	56.2	575	—	-070	E.S.E. light breeze, cloudy.
Q	11	57.8	50.2	29.83	56.7	586	—	-070	E. by N. fresh breeze, hazy.
Q	12	59.7	52.0	29.89	56.3	594	—	-080	N.E. fresh breeze, fine day.
Q	13	60.2	53.3	29.83	58.1	629	-180	-053	N.N.W. squally, cloudy.
h	14	58.1	52.0	29.92	56.3	575	—	-070	N.W. blowing fresh.
Q	15	57.3	51.6	29.95	55.8	577	—	-060	N. by E. fresh breeze, damp.
Q	16	56.5	50.7	29.97	54.2	579	—	-060	N. by W. light airs, showers.
Q	17	55.1	50.0	30.00	53.9	580	-040	-080	N.N.E. fresh breeze.
Q	18	56.3	45.7	30.02	54.2	473	—	-090	N.E. fresh breeze and fine.
Q	19	55.8	47.0	29.93	55.8	542	—	-085	N.E. to N. fresh breeze.
Q	20	54.6	47.1	29.80	54.6	500	—	-125	N. fresh breeze, fine day.
h	21	54.8	47.6	29.50	53.4	638	-128	-080	N. to N.E. light wind, hazy.
Q	22	58.0	47.6	29.51	55.4	607	—	-070	N.E. fresh breeze & squally.
Q	23	58.9	50.4	29.53	58.7	694	—	-050	N.N.E. blowing hard.
Q	24	59.6	51.8	29.87	54.8	614	—	-085	N.N.W. light airs, cloudy.
Q	25	57.8	51.0	29.94	57.6	568	—	-100	S.W. light breeze, sunshine.
Q	26	57.7	51.3	29.78	57.7	515	—	-100	S. light airs, cloudy & hazy.
Q	27	58.6	51.3	29.56	54.2	625	-250	-070	S.E. light airs, fine rain.
h	28	56.4	51.0	29.35	55.9	606	-057	-060	S.E. by E. light, cloudy.
Q	29	57.0	51.3	29.26	57.0	595	-115	-080	S.S.E. fresh breeze, cloudy.
h	30	57.8	51.4	29.27	57.8	500	—	-079	S. light breeze, fine weather.

TO READERS AND CORRESPONDENTS.

BEING unable to return special answers to the very numerous communications of our Correspondents, a process which would engross the whole of our time,—we request the latter, in general, will accept such brief notices as we may, when necessary, offer in this corner. We farther request that they will at all times do us the justice to believe that their communications receive the attention to which they are entitled.

Will Captain "A—B—, R.M." be good enough to do as he proposes, and transmit to us the revised MS. of his paper which we shall insert, the first opportunity? "N. C." just in time to be too late. Next month. Meantime, there is an ample field for his lucubrations.

"D. D." will do. We shall write the moment our present task is done.

"Verax," "Medicus Senex," "An Old Talavera Man," "Miles Britannicus," "An Officer of the Line," &c. have reached us too late for the present month.

We shall attend to "Captain G—'s" memorandum.

We fear the subject of "An Admirer of a Gallant Man" would be deemed invidious.

To the query of "W. T." we beg to reply that the appointment of Major of Brigade is independent of the General Officer Commanding the Brigade, as far as not being liable to be changed or dispensed with at the pleasure of the latter. The Major of Brigade is appointed by Head Quarters, and is, strictly speaking, attached to the Brigade or Garrison, and not to the *personal* Staff of the General Officer.

A great number of communications are under consideration.

REFORM.

" Was zieht ihr die stirne finster und Krans ?
 Was starrt ihr wild in die nacht hinaus,
 Ihr freien, ihr männlichen Seelen ?
 Jezt heult der Sturm, jezt branst das meer,
 Jezt zittert das Erdreich um uns her,
 Wir wollen uns die noth nicht verhehlen."—KÖRNER.

WE are reformers: and most officers of fortune who have in every gazette seen young men of rank and family, who had not left school when the war closed, promoted over their heads, are as decided reformers as ourselves. But, anxious as we may be for the removal of practices that, owing to altered times and manners, have gradually grown into abuses, as well as for such an improvement in our institutions, as the increase of knowledge and the general advance of society seem naturally to call for; we cannot, without sorrow and apprehension, contemplate the progress of Lord John Russell's bill, because we think it a measure that, under the salutary name of reform, threatens the complete overthrow of the constitution—of that constitution too, be it always recollected, that has tended to make these comparatively poor and barren islands the most beautiful spots of this beautiful world; that has placed the men of Britain at the head of all the arts of war and peace, and made them the dread and wonder, as well as the envy, which is never unmingled with hatred, of all surrounding nations. From this high station, the proudest to which any nation ever attained, the reform bill, if passed into law, will be the first, but irrevocable step downwards. Our descent may not be instantly perceptible, but like a mass loosened from the highest pinnacle of the cliff that moves slowly at first, till gaining strength at every bound, it descends at last with a degree of fury that sets resistance at defiance, and carries every where ruin and devastation before it in its way; so must a people constituted and situated as the people of Britain are at this day, when once fairly detached from their old laws and institutions, rush down the steep of moral degradation till arrested by some of those great revolutions of empires, or convulsions of nature, that are far beyond the bounded reach of human speculation.

Anxiously as we always avoid politics, in order to devote our attention to the various branches of knowledge connected with the difficult duties of the professions to which this Journal is particularly dedicated, (and what branch of human knowledge is not more or less connected with the profession of arms?) we nevertheless cannot allow a measure so fraught with ruin, to pass unchallenged; and proceed, therefore, in the plain language of soldiers, who as such can belong to no party but that of their country, and must at all times be far above the influence of mere factions, distinctly to state the grounds of our belief in the pernicious tendency of the proposed bill.

In the early stages of regular governments, the great advantage of popular representation is, that it makes the executive acquainted with the wants and wishes of the people at large, and infuses some part of their feeling into the administrative power of the country. But, in exact proportion as public opinion gains strength, and obtains other means of influencing the acts of government, in the same proportion

must the popular or controlling branch of the legislature, amalgamate to a certain extent with the executive for its own preservation, acquire new powers from the strength of the power it represents, take upon itself the fulfilment of new duties, or fall to the ground as altogether useless. Because, being originally intended as the representative of public opinion only, its functions naturally cease as public opinion acquires sufficient strength to make its own way without the aid of such representatives. The representative branches of the legislature are the guardians of public opinion in its infancy, but as mere guardians their aid is no longer required when the ward has grown up to manhood. And exactly in proportion as popular opinion rose to its present gigantic height in England, so did the Commons, owing to the happy working of our constitution, acquire independent strength with the general progress of knowledge, till ceasing by degrees to be a mere controlling power, they gradually concentrated in themselves the whole power of government. Though, in some measure, dependent both on the crown and the people, they yet possess the power of arresting popular encroachments by the aid of the crown on one side, and of checking the crown itself by controlling the supplies on the other; the whole forming thus the most beautiful and perfect piece of government-machinery the world has ever beheld. To call this constitution that has grown with us from our infancy, has adapted itself with wonderful pliability to all the changes that centuries have produced in our strength and situation, as well as to that proud national character which it produced, the work of mere human hands, would be the very height of presumption; for what the present race of intellectual giants can achieve in such matters has been amply illustrated by the half hundred *perfect* constitutions manufactured in our own time; all of which, from those we ourselves bestowed upon Corsica, Sicily, and Portugal, down to the last French *charte*, fell to the ground amidst the universal scoffs of the very people for whose good government they had been devised.

The salutary balance, held, as above stated, between the crown and the people, must be entirely destroyed by Lord John Russell's bill, because, by surrendering to the lower orders the power of electing an overwhelming majority of that House of Commons which already possesses the whole power of the government, we in fact surrender the government into the hands of the democracy; for a House of Commons returned at the pleasure of the mob, must ultimately be as subservient to that mob as any other agent must be to the will of his employer. Unless, therefore, the other branches of the legislature are strengthened in proportion, and rendered capable of balancing a reformed House of Commons, for which no provision is made in this bill, the present government of King, Lords, and Commons, is at an end, and a pure democracy, the real object of the radical party who are strenuous supporters of the measure, must follow as a matter of course, under whatever name and form it may at first be disguised. The consequence will naturally be, that, in total disregard of the first principles of government, which show that it is only by following a steady and consistent course of enlightened policy, often even very much at variance with public opinion and momentary benefit, the country ruled by democracy will be ruled as democracies invariably are, by the impulse of the moment, by the wild theories of the designing speculators, over whose

plans some passing gleam of prosperity may have shed a false lustre, or by the ravings of infuriated demagogues, acting on the passions of the multitude during those periods of distress to which all commercial and manufacturing states must at times be liable. Some of the evils resulting from this constant fluctuation may be here briefly pointed out.

It has been the pride of this country, and one of the main causes of its prosperity, that no person holding any official situation, civil or military, has ever in modern times deviated, in the discharge of public duty, from the path of rectitude and honour. We have suffered, as well as our neighbours, from the occasional folly and incapacity of public functionaries: we have seen full blown folly in pretty high and conspicuous situations, but treachery and worthlessness no where. Men have often enough acted like fools, but to the extent of their capacity they could always be depended upon; they never acted like knaves. Will such a proud boast be maintained, and can consistent conduct be expected under a government that will not itself have the power of being consistent, but must change and sacrifice its measures as well as servants, according to every passing whim of despotic democracy? Will men be conscientious and zealous in carrying into effect the plans and orders of Ministers, who, together with their followers, may from day to day, *at the caprice of the mob, be denounced* as the enemies of the people; and who, like the generality of such ephemeral rulers, will not hesitate to sacrifice their subordinates whenever it may suit their own views or convenience? Will not public functionaries under such circumstances, make the most of their precarious situations, and trust to immediate peculation, instead of looking forward to honourable distinction as the reward of duties faithfully performed? will they not neglect the acts of grace from which they can derive no individual advantage, and turn measures of necessary severity into means of oppression for the mere gratification of selfish views? Such, at least, is generally the conduct of men holding office under weak and unstable governments; and for the faults of public men the people suffer. The Turks are, according to their laws, as free a people as any in Europe, but the government is, or was till lately, destitute of power; the country was rapidly going to ruin, because the public functionaries were shamefully venal in a country where even the poorest Moslem is proverbially honest. The laws and institutions of Portugal have been the admiration of all jurists; but there is neither law nor justice to be found in Portugal, because (leaving Don Miguel and his contemptible set entirely out of the question) the government, however well disposed, could never, even under the great Marquis of Pombal, depend on its orders being carried into effect, owing to the negligence, treachery, and venality of its public functionaries. Poland, before its dismemberment, was a Royal Republic, where, according to the fashionable theories of the day, men could hardly fail to be free, great, and happy, for no one possessed much legal power; but as might have been expected, the only freedom known in the country was that maintained by the sword, or purchased with gold. The natural consequence of such a state of things, was the almost unresisting fall of a brave and gallant people.

It may, perhaps, be urged, that democracy has not produced in America the effects we have ascribed to its sway. This is perfectly

true as to fact; but our cases are totally dissimilar: for not only are the people of America from character, circumstances, and situation hastening rapidly towards aristocracy, whilst we are taking an opposite direction, but we unfortunately want the millions of uncultivated acres that constitute as yet the safety-valve of the feeble institutions of the great Trans-Atlantic Republic. In that country, as soon as a hale and active man, (and such only can be troublesome,) finds work scarce, or his situation uncomfortable, he shoulders his axe, and instead of taking counsel and advice from modern philosophers, crosses the Alleghany and begins to hew down trees and to clear land. These healthy pursuits naturally scatter the population over an immense tract of country, and place them not only beyond the reach, but also beyond the influence of demagogues. A people so situated, and happily removed from all immediate contact with foreign states, hardly require any government beyond what is necessary for conducting their few and simple fiscal and police regulations. The very reverse, however, is the case in this country, where a dense population of artisans and manufacturers are, from their crowded situation, from unhealthy and soul-souring pursuits, as well as from their fluctuating means of subsistence, constantly exposed to the arts of agitators, incendiaries, and mob-flatterers, the vilest of all flatterers, because flattering the lowest of passions.

It is deeply to be deplored, that the excitement now existing on the subject of reform, renders any calm discussion of the merits of the Bill totally impracticable. The lower orders and all commercial men have unfortunately been led to believe, that some tangible benefit is immediately to accrue to them from this favourite measure; and as a great part of the press have aided, and are still aiding to spread this pernicious delusion, no one taking a different view of the question is likely to be listened to with patience or attention, though one single fact is sufficient to show the lamentable fallacy of the expectation. We have already a reforming ministry, composed, for they are English noblemen and gentlemen, of high-minded and honourable individuals, anxious to improve the condition of the people, and possessing all the powers that Government can *constitutionally* hold; yet they have honestly declared their inability to grant any immediate relief. To look, therefore, to reform for relief, which cannot be granted consistently with the present constitution, is to look for such relief from measures that we should now deem unconstitutional, to be carried into effect, therefore, only by an overthrow of the constitution. And before whom is this glorious fabric, raised by the wisdom of centuries, that has been the admiration of the wise, and has stood the war-shock of ages, now destined to fall? Not before the fleets and armies of the banded world—for anxious as our friends and Allies might be to make the attempt, they yet know us to be their superiors—nor are we to fall by the hand of some of those giants in intellect, occasionally sent into the world by Providence, in order to raise up the fallen, or to humble the mighty among the nations; for in vain do we look around for such a man; in public life there is but one iron-handed giant, and he wears a turban, and is already amply occupied: in the Christian world, such is the universal feebleness, that the general direction of affairs has everywhere been assumed by a poor set of party writers; men totally incapable of estimating the value of

political institutions, or of forming just theories for the guidance of governments, because, as every page of their writings shows, they are as ignorant of history, that is, of the manner in which men have acted, and may act again, in the different situations in which they may have been placed, as they are ignorant of the springs and passions that influence human actions. These men, destitute even of moderate talents for sophistry, and capable of making the worse appear the better part only by direct misrepresentation, have yet by boldly imposing on the ignorant, by overwhelming the enlightened with insults, by evading reason, and repelling inquiry, collected under the banner of radicalism and disaffection, a crew whose loud and incessant abuse of the institutions of their native land, now threatens the overthrow of all that is great amongst us, and can only, except in superior powers of mischief, be compared to the howlings of certain Negro sects, against that very sun whose rays warmed, fostered, and supported them.

“ Le Nil a vu sur ses rivages
 Les noirs habitans des déserts
 Insulter, par des cris sauvages,
 L'astre éclatant de l'univers.
 Crime impuissant ! fureurs bizarres !
 Tandis que ses monstres barbares
 Pousaient d'insolentes clameurs,
 Le Dieu, poursuivant sa carrière,
 Versait des torrens de lumière
 Sur ses obscurs blasphémateurs.”—LE FRANC.

It will perhaps be said, that so general a cry for reform could not, in an enlightened age, have been raised against the present state of the constitution, unless some strong grounds for change had been made out. We have already stated that we are reformers, and allow therefore that improvements may be made in the state of the representation; but those who think that the imaginations of men cannot be so far exalted, and their passions so far, and so univervally roused, as to lead them into the wildest extremes in pursuit of imaginary good, when, above all, as in the present case, personal advantages are expected to result from it, know deplorably little of men, and above all of Englishmen. For, as a people, we are naturally generous but unreflecting, easily led to believe in specious theories of universal happiness, totally incompatible with the present nature of imperfect man; and we are also, with all our faults, a sanguine and enterprising people in the cause of virtue, a fact amply proved by our many foolish payments and crusades in support of far-fetched schemes of liberty and philanthropy. It is also the natural tendency of that partial degree of instruction to which the mass of the people of this country has slowly attained, and beyond which the mere mass of the present description of men can but slowly proceed, to feel impatient at restraints, the necessity of which, for the good government of the whole, they cannot always perceive; as well as to be easily instigated to hate and envy the classes possessing superior advantages, which inferiors too often think equally due to their own merit and knowledge, the great mediocrity of which they are not so apt to discern. None know better than military men, for none have such opportunities of judging, that there is much, very much of high talent, worth, and virtue, to be found among the lower orders in this

country ; but, as in all ranks, the presumptuous are of course the most numerous. No laws of mere human instituting will ever, in this world, place all men according to their relative worth and merit, nor would they, if so placed, be satisfied ; for few are those indeed who justly estimate themselves ; were an agrarian law for the equal division of property passed to-morrow, the same principle would at the end of a month again call for its renewal. It is by flattering the good by calling forth and fostering the evil passions naturally resulting from such situation and character, far more than by advocating and proposing any great and intelligible plan for national improvement, that the radical press has attained its present dangerous influence. This is rendered sufficiently evident by the fact, that no two of the party agree as to the specific benefits that are to be derived from the bill : no, *give us the bill* is the only cry and then we shall do wonders, but what the wonders are none seem able or disposed to tell. We shall therefore try our hand at the task, though pretty well aware how all unflattered pictures of favourites, whether measures or mistresses, are received by their respective worshippers.

We shall begin with the frank avowal, that we do not believe England can now maintain her station or ultimate independence under a democratic government ; because the democracy of England is at present principally composed of men closely connected with, or altogether dependent upon, trade and manufactories. Mere commercial bodies will always be found inferior to others in moral strength and greatness, because it is wealth and not fame that forms the object of trade : and as the policy of a country must naturally soon fall in with the views and interests of its governors, every other source of national greatness and prosperity will by degrees, imperceptible at first perhaps, be sacrificed to the advancement of this one favourite pursuit ; though history, to whose melancholy but instructive pages we must constantly refer, amply shows that no merely trading nation ever was a great nation, or able to maintain for any time its dignity and independence. We are far from wishing to say, that any of the present merchants or manufacturers of England would knowingly sacrifice one iota of national honour to views of personal enrichment ; we think too well of our countrymen, of men brought up under the noble institutions whose approaching fall we are so deeply deploring, to entertain any such opinion ; we know, on the contrary, that, taken all in all, there exist not in the country a more high-minded set of men than the merchants of Britain ; but we do believe that the spirit of trade having once obtained supreme sway, will, as a matter of course, lead to all the evils that the base thirst of gold "is heir to."

"————— Quid non mortalia pectora cogis,
Auri sacra fames?"

Then we shall see Nature banished from the land, our beautiful country covered from end to end with rail-roads, pestiferous manufactories, and smoking steam-engines. The yeomanry of England, once the pride of her kind, will be transformed to sallow and emaciated manufacturers, reduced to the lowest state of human existence, in order to undersell the unhappy manufacturers of the Continent ; and the men who could yet, were justice done them, carry the majestic world before them in their way, will be forced, as competition increases,

to act the parts of begging pedlars and artisans to the rest of Europe, as the Italians are now its fiddlers and panders. Even the warlike and turbulent spirit of aggression, which, contrary to the assertion of the liberals, has so invariably distinguished democracies, will hurry on our fall; for the penurious spirit of commerce will dismantle fleets and disband armies, and the proud banners of England will be struck to the loud shouts of those enlightened economists, who think that armies, and not the evil passions of men, are the causes of war: and who seek for the universal happiness principle in a state of overstrained commercial exertion, totally incompatible with individual strength, health, and virtue; the only real foundations of human happiness. Then will arrive the halcyon days when wars of foreign intervention will be needless; for foreign states will fight their own battles as well as ours, at our expense, and if need be, on our own soil, just as the wars of Italy are fought at present. Deprived of the protection of fleets and armies, or defended only by armaments raised for the moment, and alike destitute, as such armaments always are, of professional skill, feeling, and honour, our colonies will, one after the other, pass over to our more powerful rivals. Russian fleets, issuing from the Bosphorus, will convey to India those armies that never could have found their way thither by land; the freemen of America will extend their protection to the slave-owners of Jamaica, in order to protect them from the scalping knives and cutlasses of black preachers and reformers. Atheistical France may also in time be prevailed upon to fraternize with Catholic Ireland, for the purpose of protecting that unhappy country from the double tyranny of England and of Rome.

“ ’Twere sad to tell, and long to trace,
Each step from glory to disgrace; ”

but as, in these times of manufacturing rivalry, commercial privileges must be purchased by concessions, the independence of the country will be yielded up step by step to obtain momentary relief in periods of distress, which must of course increase in frequency and pressure with the increasing dependence of the population on trade alone. So that in the end, we shall see Portsmouth, perfectly useless to a nation destitute of fleets, yielded on true utilitarian principles, to France for the temporary advantage of supplying her markets with cotton. And Edinburgh Castle, a mere burthen to a liberal people above national prejudices, surrendered to the Russians for permission to send broad cloth to the Baltic till the issuing of the next Imperial Ukase.

But what would this country be without trade?—will probably be asked by those of our adversaries who consider this unmeaning and everyday question a settler to all political speculations not having commercial supremacy for their leading object. It is easily answered:—No country, even in the earliest stages of civilization, can be altogether without trade; nor can any country in the present state of European civilization well be without foreign trade; though it is the striving of America, as well as of the continental states, particularly of liberal France and liberal America, to render themselves as independent as possible of all foreign, and above all, of British import-trade. But, besides the rude state of no trade, which is now of course entirely out of the question, and a profitable and honourable trade, there is also an overwrought trade, which can only be carried on at the ultimate ex-

pense of national wealth, worth, and morality: this trade, which soon destroys the healthy capital of a nation, is but a "gilded halo hovering round decay," and to this we think that a mere commercial and democratic supremacy would inevitably lead us. How far the mere spirit of trade will lead men independently even of the pressure of national want, is amply proved by the humiliations the Genoese and Venetians submitted to from the Turks, for the sake of the early Levant trade, as well as by the degradations by which the Dutch purchased the paltry advantage of sending an annual ship to Japan.

What this country and its people were in less commercial times, may also be mentioned for the information of the upholders of trade to the exclusion of every other interest. All the historians of the middle ages agree in stating, that the English were by far the most beautiful race of people in Europe; and it may be fairly doubted, whether great national beauty can be separated from national comfort and happiness: they were also confessedly the most active, athletic, and warlike people, that is, they possessed in the highest degree, all the virtues of those times, and they were further the conquerors of France, and their country was termed "merry England." In our commercial age, thanks to tacticians, liberal and political economists, the conquest of France was found no such easy matter, and the term of "merry England" is remembered only by the singular contrast it suggests to commercial England. That our people still retain many of their personal qualities is true, but no one can visit any of the great manufacturing towns or districts, without perceiving how much they are already on the decline. Commerce, "more unsteady than the southern gale," has brought us wealth, certainly; it also forwarded, as it always does, the early stages of our civilization; but it has also brought us many evils: whether it has brought us a counterbalancing quantity of virtue, is the question its upholders have to answer before they can demand further powers, certain of extending its already wide-spread influence.

There is a point of yet lingering national character, that renders any great change in this country exceedingly precarious. We are, of all the people of the earth, the most obedient to the laws to which we know that submission is due: but we acknowledge no superior but that law, and the moment any other is attempted, even with a good intent, John Bull at once assumes his pugilistic attitude, and becomes the "free-born Englishman," the most intractable and insubordinate of all God's creatures. This noble spirit of independence fits men for the conquest of the world, but makes them very dangerous tools for political experiments. They are submissive to the laws that have been handed down to them from their forefathers, because they know that universal obedience is due and paid to such laws. Once freed, however, from those moral bonds, who shall bring the giant, intoxicated with power, back within the bounds of social discipline? Who shall convince him of the necessity of a new order of things he may not like? And whence shall come the power of enforcing obedience? As a matter of abstract right, none will deny that all who pay taxes are entitled to be fairly represented—but as soon as representation becomes power, as in the case of electing the *governing* branch of the legislature, then the thing is widely altered: for the community have then a right to demand security from all who exercise such power and trust, and therefore insist on the security of property, till the better guarantee

of character is established. And exactly in proportion as the powers of the elected increase, and it now constitutes the supreme power of the country, so does the responsibility of the Elector also rise, and in the same increasing proportion should security be demanded of him for the exercise of that power. In private life, no man trusts his fate and fortune to an unknown individual without ample security; but in public life, when the fortunes of all are at stake, we are, it seems, to follow a different line of conduct. Many think, indeed, that the Bill cannot possess the democratic tendency we ascribe to it, because the able and upright men who brought it forward would be the very last to seal the doom of their order by such a measure. To say nothing here of the strange project of diminishing the number of English members and increasing those of the sister Isle, at the very time when Ireland was almost in a state of rebellion, and when the dignity of the House was suffering from the conduct of some of the Irish members within its walls; we need only point to the results brought out by common arithmetic, and fully verified by the late election. And those who trust to mere men in such matters, forget, or know not, the effects that years of strife and opposition will produce on the minds of the wisest and the best. Reform has been a party question during the whole of the political lives of its present supporters; loudly cheered by one party, and fiercely assailed by the other, they have grown grey in fighting its battles with zealous consistency, and it is the natural tendency of a contest so carried on to raise and fire the imagination, and to hurry ardent men far beyond the bounds that sober judgment would prescribe.

Before endangering, in these times of excitement, the very foundation of social order, in the idle hope of bettering the condition of the people, by what we are pleased to term a reformed system of government, let us first try what can be effected by self-reform, and give our ancient laws and institutions a just trial; for no political institutions, however perfect, can lead to beneficial results unless virtuously acted up to. Let us therefore cast liberalism, radicalism, exclusiveness, and tinsel-hunting to the dogs: let us in every sense of the word, return to our country, to British feelings, and if it must be, even to British prejudices. Let the name of a Briton be a passport to British sympathy instead of British *hauteur*: let us aid each other in sorrow and in suffering, and cheer each other in prosperity: and let all ranks take a pride in aiding to forward and uphold the honour and happiness of their native land. When this reform shall have been carried, a reform in our political institutions may be safely and easily undertaken; and it will then probably be found, that they require no such sweeping change as that proposed by Lord John Russell's Bill.

At the breaking out of the Irish rebellion, several fencible regiments, composed of the finest men, perhaps, that ever carried arms, were raised at the mere beck of the great proprietors of Sutherland, Caithness, and Ross. Those once populous districts are now "one sheep-walk waste and wide;" sheep have displaced the men, who have been forced to emigrate, or to seek employment in the sickly and demoralising manufactories of Glasgow, Paisley, &c. &c. A few landlords have been enriched, and political economists and empirics have boasted of the improvement of the country, at the very moment when they were laying the axe to the root of its prosperity. This system,

which began in England and swept over Scotland, is now proceeding in Ireland: that it tells more against the aristocracy than the democracy is true, and, therefore, is it here mentioned. We formerly stated,* that, "bating what is effected by fashion, the tendency of which is at present decidedly hostile to all manly and patriotic feeling, the aristocracy of England contain within themselves more of the elements of real greatness, than are to be found in any other class of equal numbers in any country in the world;" and though we still adhere to that opinion, we nevertheless think that their general conduct has greatly tended to bring about the present crisis. They, too, were influenced by the spirit of commercial times, bent the knee to mammon, set an example of subserviency to power and riches, that was so promptly imitated by all ranks, that no man could in the end stand upright in the presence of his superior in fortune, and the relative wealth of the community might almost have been ascertained by angular measurement. Instead of upholding national manners and feelings, they became Liberals, resided and spent vast sums in France and Italy; trained up their sons and daughters in the anti-British ideas, so carefully instilled into all youthful minds in the virtuous convents and seminaries of those moral countries. Not only affable, but often cringing abroad to the most despicable of foreigners, they were at home cold, haughty, and distant, to their countrymen, seeking in exclusiveness the most wretched of all distinctions, because the easiest to be attained, and never sought by those who have other means of attaining honest celebrity. The matrons of England too, whose fame once stood so high, that fifteen years of peace and slander have not been altogether able to shake it, might every night be seen at Roman conversazioni, associating on the most friendly terms with the married women of Italy, whose conduct is not attempted to be disguised: whilst the young ladies of England studied gallantry in those French and Italian coteries, in which the young and the unmarried native women are very properly never allowed to appear. As it is not given to all to grasp the full grandeur of British institutions, and to understand the manners naturally resulting from them, many of our travellers—for in all these matters the aristocracy of wealth were but the paltry imitators of the aristocracy of birth—captivated by the fripperies of foreign manners, as more congenial to little minds, tried to import and naturalise such exotics amongst us; and thus broke the last link that still connected them with the lower orders, who unwillingly granted even a constitutional power to those who no longer shared in the national feelings of the people for whom they attempted to legislate.

That for such conduct the aristocracy can make no better claim than the mercantile interest for an extra-constitutional share of power, is sufficiently evident; and if they have acquired any such power, beyond what the time-serving spirit of the age will always enable wealth to command, let restitution be demanded in a tone that shall ensure compliance; but let us not, on that account, overthrow the balance of the constitution; let us not rush into wild democracy in order to escape from aristocratic influence. Let us have reform, not founded, indeed, on the theories of Radicals, who would make us believe that kings,

* P. 302, No. 28, March 1831.

lords, and laws, are the only bars to the perfectibility of man, and the immediate arrival of the millennium, but a reform that shall leave us the constitution of King, Lords, and Commons, unimpaired. And a very slight alteration in the representation will be sufficient to effect this; for the last election has triumphantly proved that self-reform is, after all, the reform principally wanted. The opposition press even carried hollow every point it took up against the Wellington Administration, and some of those points were verily not of the wisest.

We have taken up this subject with regret, and in sorrow and with bitter forebodings do we close it; for, speaking from professional feelings, perhaps, we must say, that nothing has struck us as so sad a sign of these evil times, as the lamentable facility with which public men have been driven from the discharge of their duty by mob clamour and newspaper abuse.

Ἦ πείσους, τάχα δὴ τι κακὸν ποιήσετε μίσην
 Τῆδε μεθυσσύνῃ· ἀλλ' ἐν φρεσὶ Σίστη ἕκαστος
 Ἄδω καὶ νόμισιν· δὴ γὰρ μίγα νόμος ἔραρον.—*Iliad Lib. xiii.*

A conscientious change of opinions we can easily understand, but to retain opinions honestly formed, and yet to retire, brow-beaten, from a contest on which the fate of England depends, is to us a fearful and incomprehensible novelty in the character of Britons. In such a cause as the present, it is the duty of all who fight from conviction, to fight to the last,—for submission but emboldens the foe,—and to yield, because the battle seems hopeless, is a craven weakness that has lost many a fair field that firmness might have retrieved. It is the last fight for the proudest mental fabric that ever adorned the earth, or helped to enlighten mankind. The eyes of the world are on the combatants, and as the defenders of our time-honoured institutions neglect or perform their duty, so will the present and the future scorn or laud their names. There was no want of despondency in the army towards the evening of the battle-day of Waterloo. The Dutch and Belgians had been scattered “like chaff before the wind of heaven;” masses of hostile infantry, like dark and overcharged clouds, seemed ready to burst in thunder over the remnant of the British band, who, forced into squares by the overwhelming superiority of the French cavalry that everywhere swept the plain, presented almost infallible marks to the iron hail that hundreds of pieces of artillery were pouring in upon them: if in such extremity, when hope seemed none, and when death had for hours strode triumphantly through their thinned and bleeding ranks, not a single soldier, of the humblest name and station, left his post; shall it be said that the high and the noble of the land shrunk from their duty, when the constitution of their country was to be upheld; shall those who carried their heads so high on the mere strength of the physical courage displayed by sailors and soldiers, be in the hour of trial found totally wanting in the higher quality of moral courage? Perish the thought! and if we too must fall; if the constitution of these realms is to sink in the universal tempest that is now sweeping over Europe, let its sworn defenders behave at least in a manner worthy the cause confided to them, and go down with the flag of duty and of honour nailed to the mast-head.

LETTERS FROM CONSTANTINOPLE.

NO. I.

AMONG the recent improvements that have taken place in the Turkish Empire, there is none that marks so strongly the approximation of the people to European habits and feelings, as their entertaining an idea of establishing a Quarantine against the infection of plague. As this circumstance forms a momentous era in their history, and the subject seems peculiarly appropriate to the Naval Department of the United Service Journal, I shall confine myself in this communication to a description of the intended establishment, with the incidents which have led to its proposed adoption. It will, in all probability, be the first notice of it published in Europe.

The strong and extravagant notions of predestination entertained by the Turks, have hitherto been carried so far, that they deemed it an impiety to take any precaution against whatever Allah was pleased to send. Till very lately, they rejected vaccination on this principle; but a Frank physician having persuaded them that it was not a prophylactic, but a therapeutic, not intended to prevent a disease, but to heal one already existing in the human constitution, they were satisfied with the distinction, and when the Sultan had some of his children vaccinated, many others followed his example.

After the awful visitation of the plague in 1812, they could not be persuaded to take any measures of safety, though they saw that the Franks, who shut themselves up from contact or communication, generally escaped amidst the carnage that surrounded them, nor was it till 1000 persons a day were brought out of the top Kakousi gate to be buried, that they would suffer even prayers to be offered up in the Mosques that the plague might be stayed, deeming even *that* a murmuring and a want of due submission to the decrees of Providence. Some years after, however, the disease again appeared among the Pashaw's troops encamped at Buyukdéré, and the Turkish soldiers were for the first time observed washing the clothes of their deceased companions, and hanging them to dry outside their tents. Many a Frank was greatly alarmed, when passing by he incautiously came in contact with these infected articles, notwithstanding the depuration of air and water, which he could hardly believe the Turks would ever attempt.

But it was after the late Russian campaign, that they began seriously to consider the absurdity of their opinions. They saw the ravages the plague made in Wallachia, and the effectual precautions taken by their enemies, which, in many instances, arrested its progress and finally subdued it; and as they adopted their military discipline, they also thought of profiting by their example in other respects. An energetic Pasha seeing the plague break out in his district, drew a cordon round the village where it appeared, and suffered no one to pass either in or out on any pretext. After some time, every thing was silent, and on examination, it was found that the whole of the population was dead, but the disease never extended beyond the spot where this fearful

precautionary sacrifice was made. Some time after, the monks of a convent in Syria were infected, and the Pasha of Acre interdicted in a similar way any communication with them; some of the brethren died, but the distemper did not appear beyond the walls of the monastery.

These and similar occurrences induced the Turks to entertain serious notions of adopting the precautions of other nations, with a view to disarm the most dreadful and destructive enemy by which they have ever been attacked. A short time ago, application was made by the Turkish Government, to the British minister here, for a plan of a Lazaretto to be established at Constantinople on the European principle, with a view to prevent the introduction of the disease from abroad, and extinguish it at home. This application was forwarded to England, and orders were sent to Malta, that a plan of the Lazaretto of that place should be sent as a model. But the superintendent, Mr. Greig, having examined it, found that there were many objections to it. It had been erected by the Knights at a time when the island had no commerce, and there was no provision made for the depuration of suspected goods, besides it was an establishment formed when every thing of the kind was imperfectly understood, and it was necessary to make sundry alterations and additions to the original establishment; it was, therefore, decided to draw up a plan of an entirely new edifice, in which all the improvements made by time and experience in the old one should be embodied.

The direction of this was given to Capt. Schemloi, an active and intelligent native of Malta. He had been employed by the local government during the plague which visited the island in 1813, in directing and paying those who removed the infected bodies, and executed his hazardous duty so effectually, that he was requested to continue a Superintendent of the Quarantine, and was appointed Captain of the Marsa Musceit, or Lazaretto Harbour, which he had held ever since; and it was supposed that his experience, for nearly twenty years, would render him the most efficient person for such a duty.

On the 1st of May 1831, Capt. Schemloi arrived in Constantinople, with his plan for the approbation of the Turkish Government, the adoption of which will form a new and extraordinary era in the annals of Ishmaelism. The following are its principal features.

To form a Board of Health, consisting of a President, five native Members, two foreign Consuls, two European Merchants, one Physician, and the Captain of the Port, who will meet once a week at least, to regulate all matters connected with their department. Their first care will be to procure a firman from the Sultan, addressed to the population of Constantinople, and to every other part of the Turkish empire, apprising the public of the beneficial objects of the intended regulations as connected with the safety of the people at home, and their commerce with other nations. They will then fix on a convenient place for the erection of a Lazaretto, and a Quarantine office on the newest and most approved plan. They will take into consideration what places are liable to quarantine, and fix the period for vessels arriving with susceptible goods from such places according to the nature of their bills of health, which must be issued by the proper authorities at the places where they depart from and touched at during their

voyage. As most part of the vessels anchor at Cosple en Relache, going to or returning from the Black Sea, and are obliged often by calms or contrary winds to lie at different places in the channel, the Board of Health will appoint certain parts of the Bosphorus as quarantine grounds, where such vessels only will be allowed to anchor, in which will be a quarantine house, with proper officers to watch over their conduct. Three others of a similar kind will be established at the Dardanelles, at the Castle of Asia, and at Galipoli; and quarantine offices and lazarettoes in all the maritime towns of the coast, in order that all vessels arriving there shall be subject to regulations similar to those of the capital, and no vessel shall be allowed to communicate with the coast, if she shall not have previously performed her quarantine in the port whose jurisdiction such part of the coast is under. And, finally, the Board will keep up a frequent correspondence with the European Lazarettoes abroad; and at home apply to the Government to issue the necessary orders to all the Pashas of towns and chief villages within the Ottoman empire, to establish a proper sanitary police, and transmit to the Board faithful reports of the state of health of the respective inhabitants under their jurisdiction, and most particularly if any suspicion or accident of plague occur, in order that the necessary precautions may be immediately taken to prevent the progress of it in the district, or its importation to the capital.

These regulations combine two objects: to prevent the introduction of the disease, and then, if the precautions do not succeed, to attack and endeavour to extirpate it when or wherever it appears. To effect this latter purpose, the infected are to be separated from those who are sound, and those who are compromised removed to some place of surveillance; every article of furniture or apparel is either to be destroyed by fire, or purified by water if too valuable to destroy, and the houses are to be washed and whitewashed, and finally fumigated with a mixture of sulphur and bran.

The Lazaretto to be built will be a noble establishment; it will consist of an edifice 700 feet in length, and of a proportionate breadth, situated as near the port as possible. It will present a façade of two stories, and be entered by a side passage, with the Governor's apartments in the second story, so as to overlook both the front and the interior of the establishment. On one side of the entrance will be an office for regulating the affairs of the establishment, on the other a guard-room for a certain number of soldiers; passing this will be a covered shed, under which is the place where those in pratique converse with their friends who are in quarantine, separated from each other by bars and a railing eight or nine feet asunder. Behind this will be an open court-yard communicating with apartments on each side, neatly fitted up for the accommodation of persons detained; this court will communicate with a large space behind, extending the length of the breadth of the building, planted with trees and shrubs, as a place of recreation to walk and take exercise in. Fronting the entrance will be the stores for depurating goods, of an extent commensurate with the great and increasing trade of Constantinople, and a door in the rear for removing them when the necessary time is expired. In the centre of the court will be a large fountain, with a continued play of pure water,

and the fronts of the buildings which form its sides will be supported on pillars of Marmora marble, so as to form cool porticoes to promenade all round, sheltered from sun and rain. The first impression then of the building will be on entering, that of an elegant, cheerful, airy, edifice, calculated rather to inspire pleasing thoughts, than those gloomy and depressing reflections which other Lazarettoes cause, sinking the mind and predisposing it to any complaint.

The left wing will be dedicated to an infirmary and its melancholy appendages. It will be divided into an hospital, having two large wards, to which those actually infected will be immediately conveyed, and probationary apartments, where those who have been compromised with the sick will be placed. If any one or more of a family have been attacked, they will be removed to the hospital, and the rest who have been in constant communication with them, confined in this division of the Lazaretto, so as to have no communication with those in the other apartments who are not compromised; contiguous to the hospital will be the burying-ground, but sufficiently divided from it by a wide passage and walls. This receptacle of actual distemper and death will be properly placed in a compartment of the building which has no communication with the rest, and will be approached by separate entrances. The whole edifice will be surrounded with double walls, having a deep fosse interposed between them. This precaution is necessary to prevent any communication from the outside. It is a frequent practice with people in quarantine to throw their letters, &c. over the wall, and so circulate compromised or suspected articles abroad: any such attempt will be rendered abortive, as the thing attempted to be conveyed will fall into the ditch.

Such is the plan of this establishment which the Turks are now about for the first time to adopt; not only will it be a new era in their history, but as it will be the completest thing of the kind, it is not impossible that European nations may hereafter adopt it, and so take their plans for the prevention of the plague from those who for centuries would allow no precautions to be taken: many difficulties will no doubt occur at the commencement; the impossibility of preventing communications from the opposite sides of the narrow straits of the Bosphorus and Hellespont, when the plague rages in Asia or Europe; the natural indolence and apathy of the Turks; their long cherished principles of predestination, but above all, the expense of the establishment, will be great impediments to its speedy or effectual adoption. The cost of the Lazaretto will in the first instance be about 20,000*l.* and the general question here is, Where is the money to come from?

The present period is, however, favourable to the establishment of this quarantine. There is no plague known to exist, at least in any extent, to excite attention or alarm in any part of the empire; but abroad, in countries which hold with Turkey a constant intercourse, it prevails to some extent. In parts of Persia it rages at present, and much merchandize from the infected places proceeds to Trebisonde, from whence they are imported by the Black Sea to Constantinople. A quarantine and the depuration of suspected goods at that latter place, would be an effectual protection to the capital against the introduction of the disease from that quarter. Again, Egypt is compromised, and a

similar precaution should be taken at Alexandria. The great complaint is, that pestilence is imported from those places to the capital, and, on the contrary, from the capital to those places. The establishment of the regulations proposed would at least set this question at rest. The only objection of their immediate adoption arises from the war which has now broken out in Albania, and which occupies all the attention of the Turkish Government at this time. There is no man here who, like Cæsar, can attend to half-a-dozen things at once, and it is supposed that every thing will be suspended till this affair is set at rest. When that takes place, it is highly probable the proposed regulations will be established, particularly so as it is intended to have a tariff of expenses to be paid by persons and ships in quarantine, and the Turks will readily listen to any proposal, which not only will not cause to them any expense, but put money in their pockets.

Yours, &c. —

P. S. The annexed plan of the intended Establishment.

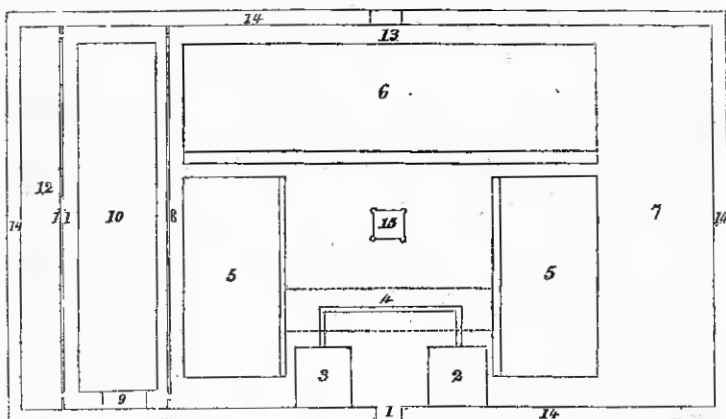

- | | |
|---|--|
| 1. Great gate. | 8. Wall which divides the Hospital department. |
| 2. Quarantine office. | 9. Place for fumigations of letters. |
| 3. Military guard. | 10. Plague Hospital. |
| 4. Shed for conversation. | 11. Wall dividing the burying-ground. |
| 5. Apartments. | 12. Burying-ground. |
| 6. Magazine for deparating merchandise. | 13. Gate for goods on pratique. |
| 7. Recreation-ground, planted with trees. | 14. Fosse surrounding the whole. |
| | 15. Fountain. |

THEORY OF THE UNIVERSE; COMPRISING STRICTURES ON
 .. COMMANDER WOODLEY'S "DIVINE SYSTEM."

"——Men, conceited lords of all,
 Walk proudly o'er this pendent ball,
 Fond of their little spot below,
 Nor greater beings care to know,
 But think those worlds which deck the skies,
 Were only form'd to please their eyes."

THE Theory of the Universe, together with the primary laws of Nature, comprehended under the general term of astronomy, constitutes the noblest achievement of human intellect. It is grounded on physics and mathematics,—the first treats of those laws of matter and motion which regulate the various phenomena of the creation, and the last, by investigating and determining the effects of those laws, raises new fabrics on a known basis; while the union of the two condenses the whole mass of facts and deductions into one common and useful series; opening to the contemplative philosopher, an intensely interesting glance into the means employed by Omnipotence for perpetuating the admirable structure. The leading quantities for the mathematical analysis of the heavens are simple in their conditions, for all the supposed deviations from a fixed order of recurrence, are but modifications of the governing principle which extends through the velocities, directions, and other motions of the celestial bodies, and are duly corrected by definite secular periods. These modifications, however, are numerous and vast; and without hard study, and a knowledge of algebra beyond simple equations, the doctrine of the reciprocal influences must remain a sealed truth. Though the same plan and government are readily evident to the tyro, still the abstract view of the principles of celestial mechanism is not to be gained by any *royal road*: human knowledge is generally slow in its progress, and especially that which is founded on the various applications of mathematics. The very language of the Calculus, through which alone the directing Providence is to be traced, is not acquired without a more intense assiduity, than many are able to devote to the attainment of analytical science. Light breaks in but progressively upon these arcana, and is long in reaching the minds of the mass of mankind: neither Hieroglyphics, Eleusinian rites, nor the mysteries of the Cabiri, were more beyond the reach of the uninitiated in ancient times, than is at the present hour, that pure and transcendental knowledge which reveals the unspeakable sublimity by which we are surrounded, and our own comparative insignificance.

With such exalted notions of the subject, we approach such discussions with becoming humility; nor indeed should we have now been drawn towards them, but for having had a volume put into our hands, entitled "*The Divine System of the Universe, wherein the Hypothesis of the Earth's motion is refuted, and the true Basis of Astronomy laid down according to our sight, sense, and demonstration.*" It appears the joint labour of W. Woodley, Esq. a Commander in the Royal Navy, and Brothers, the redoubtable modern prophet. Of these joint-stock philosophers, we are assured that the first is "a blunt sailor—a navi-

gator, practised and experienced;" the second, a maniac, who, confined in a madhouse, "wrote from his sepulchral abode, with the juice of liquorice from his mouth, on slips of paper conveyed to him by stealth." We are not surprised that the descendant of David should advocate, after his forefathers, the immobility of the earth; nor is there any thing absolutely new advanced. Both authors have evidently adopted, for the basis of their speculations, the long exploded system of Ptolemy; but they have omitted most of the philosophic detail which almost excused the artificial and complex doctrine of epicycles, eccentrics, and other ambages; and which rendered that distinguished astronomer's work of partial importance. Knowing that such a farrago must journey onwards to its oblivious and inevitable fate, we should not have deemed it worth a *coup de plume* to accelerate its course, had we not been meanwhile startled in a certain professional club-room, with the awful insinuation,—“Oh! but there must be something in it though, for none of the knowing chaps can answer it!” Whereupon, leaving the “knowing chaps” to pursue their more important duties, we, albeit not of that class, venture to make a few extracts from this specious theory: more especially as the gallant captain asserts it to be founded “on observation and calculation;” appending, moreover, a corresponding method of obtaining the longitude at sea.

Adhering only to the subject-matter, and not the man,—we may here dismiss the unhappy Israelite; together with the verses to the Bible Society, and the aphorisms, hymns, and eulogia of Mistress Johanna Southcott,—of whom passports to Heaven were lately purchased. Yet we cannot altogether quit the “sleeping partner,” without condemning the silly verbiage, mangled history, and prostituted divinity which defile his pages. “The Almighty God”—he raves, “has said to me that there is no earth but this we live on, no sun but the one we see plainly, and no people but ourselves: the earth is at rest, but the sun is in motion; the earth is larger than the sun, and the sun larger than the moon.” Fully convinced of the extravagance of Sir Isaac Newton's conceptions, he triumphantly demands,—“How could ships sail on the ocean if the globe had axical motion at the rate of 900 geographical miles an hour; or the half, or the twentieth part of it? The thing would be impossible; they would be whirled in the air, and perish for ever. No man could stand on his feet an instant; no house be built, or tree grow.” The author is not aware, in objecting to such axical motion, “like a rolling barrel,” of the incomparably greater centrifugal velocity which he assigns to the millions of splendid orbs which bespangle the heavens; and they are assuredly placed there for other purposes than to economise our lamp-oil, for we could not even see the greater part of them, except for the adventitious aid of telescopes. Hence, if man had not luckily struck upon this marvellous invention, what myriads of stars would have been made to no purpose! And is our “Divine Theorist” prepared to accuse Omniscience of creating any thing in vain?

He also remarks that if the Copernican system be true, “God would appear a designing liar, the first chapter of Genesis false, and the whole Scripture a contemptible imposition.”—“What interest has God in deceiving so grossly people that he has created to do him honour, to be just in their actions, and only inferior to himself in know-

ledge. If we do not believe God, whom are we to believe? Is it Pythagoras and Sir Isaac Newton? Their judgment was very weak, and their calculations are very false. My observations, and far superior experience to any they were able to pretend to, fully enable me to assert it."—Let it not be imagined that in extracting such ebullitions, it is our intention to turn sacred things into ridicule; it is by exposing those who profane them by imbecility and vanity, that we save religion itself from being carped at. If the declaimer had penetrated beyond the surface, and seized principles instead of words only, he could not have lost sight of the minute and never erring announcement of solar and lunar eclipses, of the beautiful accordance of Jupiter's satellites, and of the occultations of stars by the moon, all calculated on data yielded by the Newtonian "jugglery." But we pause—aberration of intellect claims commiseration,—therefore as to poor Brothers, *requiescat in pace*:

"No wild enthusiast ever yet could rest,
Till half mankind were, like himself, possess'd."

The worthy Commander sturdily advocates the prophet's "systema Naturæ," because it agrees with his own; for on making experiment with those data, he says, "it came out abundantly to my satisfaction." He commences by the trite observation that, as no "angle could be perceived as respecting the fixed stars," on a base of 190 millions of miles, therefore the earth must be stationary. In reply to this, their prodigious distance compared with the axis-major of the earth's annual orbit, is a sufficient answer. It is true, that Tycho thought it improbable they should be beyond Saturn, seven hundred times the distance of Saturn from the sun, without other stars intervening. But the distance cannot be less, since it is found that the annual parallax of none of the "fixed" stars amounts to two seconds of a degree. And as this is the angle under which the earth's orbit must consequently appear when viewed from them, it follows that the star and our orbit may be equal in magnitude! Had Tycho lived in these days, he would have learned that the planet Uranus, as well as many comets, move in orbits which extend beyond that of Saturn, into a part of that space which appeared to him so inconceivable. Many eminent astronomers have devoted their most skilful exertions to this subject, but the results, as yet, scarcely afford more than a mere approximation. The powerful aid of trigonometry, which has enabled us to determine the diameter and orbits of the planets of our own system, is insufficient for the remoteness of the "fixed" stars, and recourse has been had to measure their parallax by improved instruments, though hitherto without effect. Huygens attempted the investigation on the known principles of analogy, as considered in the proportion of light surfaces. Bradley, the prince of observers, thought that had the parallax of γ Draconis amounted to a single second, he must have detected it; and it seemed to him, that, as it does not amount to this small quantity, it is consequently four hundred thousand times further from us than the sun. The same research was followed up by observations on double stars; it being justly surmised that, if these two bodies were at rest, their apparent distance from each other would be slightly altered, according to the earth's position in its annual course; and this incidentally led to ascertaining the motion of

stars about their centres of gravity. Though the delicate assiduity required for the solving of this problem has hitherto retarded it, yet when we consider what wonders the diminutive enquirer, *Man*, has already effected in investigating the laws, constitution, and motions of the heavenly bodies, we are not without hopes of seeing their actual distances accurately established, ere long. Many particulars connected with the nature of the "fixed" stars, however, must remain in perplexing uncertainty; for they recede so nearly to infinity, that nothing short of inspiration can enable the human intellect fully to develop the sublime mysteries. The Commander boldly asserts, that they are lumps of ice, placed in the firmament merely to beautify the visible creation, and to exercise the judgment and ingenuity of man.* We happen to think very differently; and in the astonishing binary and ternary sidereal systems, we cannot but see additional stupendous proofs of the unlimited magnificence of Almighty creations.

Far from having to seek for arguments to contend with this Cosmogoner, we need only take his own words to show, that he has undertaken a burthen which must crush him. As early as the second page of the introduction, and duly repeated elsewhere we find, "That, as the great and little Bear constellations are, in twenty-four hours, whirled round the axle of the sky, an effect that could not be produced by a daily turning of the earth,—that, therefore I was assured the earth was stationary, and that the stars went round." Now, the very contrary of what the author here asserts, will be evident to those who can work out a few problems adapted to the purpose, on the two suppositions of the earth being at rest, and *vice versa*, so as to account for "the evidence of our senses," which the Commander seems to hold in supreme veneration; but which it is safer to hold subject to reason. When people first go on board a sailing vessel, they are apt to think the land is receding from them and not they from the land. The motion of the earth on its axis, would exactly produce the revolutions alluded to, and he should here have deserted Ptolemy, and adopted the Tyconic system, or rather mixture of systems, because the objections to the phenomena are rather derived from physical and mechanical considerations, than from the appearances themselves. But with the open daring of his profession, he attacks the position with other forces; Newton, the glory of England, and the instructor of sages, is taxed with deceit, in palming upon mankind, that "god of his creation," *Gravitation*, "an absurdity" contrary to every principle of mechanics.

No question admits of more convincing demonstration than that, in the case of the earth, as in that of other planets, the inclination of the axis of rotation to the orbit maintains the same absolute direction, and the same inclination to the plane of the orbit, at least with very small oscillations of very long periods. Yet St. Pierre, another aerial schemer, who gloated in assaulting the loftiest monument of human genius, readily settles this lemma. He assures the good people of France, that they have been imposed upon by the astronomers; that it is insulting to their senses to be told that the seasons are the effect

* This assertion is outdone by Mr. Charles Palmer. In his Treatise on the sublime science of Heliography, published in 1799, he asserts,—“our great orb of light, the SUN, to be absolutely no other than a body of ice.”

of the earth's rolling round the sun with the poles a little inclined. He affirms that the globe does not move; that its pole is twice a year perpendicular to the plane of the ecliptic, at which time *God comes in*, and destroys its equilibrium, by turning the North Pole a little towards the sun, which produces summer: meanwhile the South Pole, being turned from the sun, becomes surcharged with ice and snow, which again brings the pole into its perpendicular state, and produces equal day and night. He then makes God again *step in*, to turn the North Pole a little from the sun, to produce winter. The consequent fusion of the Polar ices, occasions tides to flow, and the freezings the ebb. These and other inane follies, have carried his jargon through numerous large editions! Such silliness really exonerates the prophane wit of King Alphonso. Indeed, the wretched jumble of religion and science so frequently attempted, cannot but be held reprehensible, as leading to a spirit of intolerance, which might consign a Newton to the dungeon. The morbid anxiety that points of science should be in perfect coincidence with the minutiae of religion, often betrays a narrow mind, however well-meaning it may be. "My opinion of astronomy," saith Paley, "has always been, that it is not the best medium through which to prove the agency of an intelligent Creator; but that this being proved, it shows beyond all other sciences, the magnificence of his operations."

Unacquainted, apparently, with the secular equations of Jupiter and Saturn, our philosophist triumphantly inquires for the derangement in the planetary system, as arising from gravitating power, and says that Newton, "who was unable to weigh the fire of a candle, has weighed the Sun:" here our author might have reasoned upon this "imposition" by the aid of another science, for chemistry would have taught him, that the result of combustion is exactly equal to the weight of the combustibles prior to that process. Though, as with electricity, (the *spiritus subtilissimus* of Newton,) magnetism, and galvanism, it is somewhat difficult to determine what the cause of gravity actually is, its power and effects admit of palpable demonstration. Thus the comparison of the actual figure of the earth, with that which is assigned to it by the theory of gravitation, is one of the most interesting subjects connected with physical astronomy. The usual attempts to acquire a knowledge of the resultant shape by local measurements of meridional arcs, and comparing by means of the second's pendulum, the intensity of the gravitating force at different points of the terrestrial spheroid, are tolerably well known. But many other methods, such as by occultations of fixed stars on small chords of the moon; the adaptation of the phenomena of precession and nutation; or, still more, that which consists of the computation of those inequalities of the moon's orbit, which depend on the non-sphericity of the earth, must remain sealed to all except those who are capable of exerting a deep application of the mental faculties. "Let us try" — says the Commander, "what is considered the principle of *gravity* by the test of the wisdom which is revealed to us." Who can preserve their *gravity* at such a precept; it would be about as appropriate, as trying Lord Russell's Reform Bill by the test of the Pole-star!

We must also reprove the lugging in various quotations from Scripture, to sustain hypotheses equally repugnant to mathematical know-

ledge and religious veneration. Nor can it be deemed a token of piety to condemn as absurd, that argument which is not understood; or to impute unworthy motives to men of known virtue: it were far better at once for the author to confess being out of his latitude, and a tow-rope might be thrown to rescue him from the breakers in which he is floundering. Severe application to better authorities than he appears to have been consulting, might convince him of his error; for science, equally inimical to fanatics and mystics, offers them a tangled skein; while to the true *Astrophiles* she presents a clue which faithfully guides them through the labyrinth. Water is not, however, easily extracted from pumices; and the many storm, by inspiration, all the elements—

“————— Multifarious,
Quite down from Aries to Aquarius.”

The insinuation against our great geometer's religion, and that “God is not to be metaphysically inquired after,” does not cover the baldness of the pretension to quote the *Principia*, any more than the frequent appeals to Holy Writ veil their palpable distortions. The Scriptures were never designed to instruct men in philosophy, or convey astronomical information, but as a guide in matters of religion and morality. We therefore condemn the arrogance of the passage which accuses Newton of militating against “the veracity of the Bible,”—because, “by his own rule, the earth turns round on its axis, therefore, as an effect, he says, that it is flattened at the poles; whilst, by his invented term of centrifugal force, it swells out at the equator; but how can this possibly be? For if the gravity, or attraction, that binds the earth, diminishes in proportion to the extension occasioned by the force that disturbs it, must not the centrifugal force overpower, separate, and scatter the terrestrial surface from the centre? Certainly it would; if he will have this great effect produced for making the earth turn round on its axis, why does he not allow some effect for the principal motion, of making it fly within the plane of its orbit? His system of motion shows the absurdity of his pretensions to mechanics, while it destroys his theory of gravity.” We may here remark that Sir Isaac was no less remarkable for his reverence for the Bible, than for his patient sagacity in the investigation of phenomena, his unbounded ingenuity, and his comprehensive views of the economy of nature. This great man has taught us, that the centrifugal force arising from the rotatory motion of the earth causes the particles situated at the equator to recede from the centre, thus producing an inflation there, and a flatness, or oblateness, at the poles. At the surface, the centrifugal force diminishes that of gravity by the product of the centrifugal force at the equator, by the square of the cosine of the latitude. Now, since it is necessary for the maintenance of the equilibrium, that the column, by its length, should compensate the diminution of its weight, it ought to surpass the polar column by one twentieth of its length, multiplied by the square of the above cosine. And observations, in general, bear out the truth of this “absurdity in mechanics.”

It would appear clear from the assertions before us, that Newton, notwithstanding his renown, was a mere charlatan who, having no

practical knowledge, and disbelieving the evidence of his senses, conjured up perturbations, and then ascribed them to his no less unfounded theory of gravity and attraction. "The Newtonian hypothesis, with its bulkiness and deformities, harasses, and is a torture to the mind, while it shocks, as it insults, the understanding." Here is mercy with a vengeance! "When Greek meets Greek," &c. we must not trust ourselves with the rest, but proceed to the treatise before us; only remarking by the way, that it would be imposing a hard task on Sir Isaac, to provide capacity as well as argument for every one who flatters himself with being capable of reading his works.

"The enlightened author," (meaning the poor Israelite) "upon the Divine system, observes, that *the least motion of the earth has always proved incompatible with human existence*. Instead of the earth then, the parts of which are weak, having three powers operating contrary ways upon it at the same time, one of which sends it 1133 miles a minute, so imperceptibly, as, for instance, that the wind does not blow, which in that case it would do, always one way; also, without the principal motion, which is perpetual, conquering, and bringing under the two lesser, a theory contrary to every principle of mechanics—it is at rest in the centre of the universe."

But the theory of gravitation simply teaches us that bodies are attracted as their masses; decreasing from the centre of any gravitating body, as the squares of the distance from that centre. This influence, as regards the earth, extends far beyond our atmosphere, reaching that point in space where it becomes equal to that of the sun; and at this point a body would not fall either to the earth or the sun. The same reasoning applies to the moon; and the other heavenly bodies. But the observer on this globe's surface gravitates towards its centre; so does the atmosphere which he breathes, and this so strongly, as not to be overcome by the rotatory motion; consequently the effect cannot be felt by him either. We are at a loss therefore to know how the incompatibility of the least terrestrial motion, has *always been proved*. To proceed—

"Independently of what is plainly shown to be contrary to mechanics, how could the earth fly at such a prodigious rate as it is said to do? For, if this globe, which a weighty stone is over, (say a mile,) is flying faster than the stone is dropping, (and that would be the case if the globe flew 1133 miles a minute, for cannon-balls don't fly ten miles a minute,) reason, observation, and mechanics, teach that it must be left behind. As to attraction under such circumstances, it is absurd;—we know that a bullet disconnected from a flying body will partake of the motion for a few seconds; but what analogy has that with the earth's carrying a balloon, birds, and clouds along with it? A cannon-shot dropped from a mile high will fall upon the spot it is immediately over; but philosophers would say that it has been carried on while it was falling at the precise rate that the earth is flying at—how extraordinary that it should be exactly!—Then, fire a cannon-ball perpendicular, if it be possible, into the air; still will it come down upon the spot it was fired from; notwithstanding, there must have been an additional attraction to subdue the force of the ball from the cannon. As then the earth's attraction can have no such discriminating power as this, and as a ball fired in the direction the earth is said to be going, will go no farther than a ball fired in the opposite direction, it is plain that philosophers have been dreaming of being carried along by the earth's attraction ever since Copernicus set it in motion. All experience teaches that a body flying, as a cannon-ball (and that is the only rational, and reasonable analogy, to a

flying earth,) must make a wind proportioned to its size and rate of going. What could exist then on the earth if it had the motions given to it?"

Tycho Brahé, who caused the sun and all the planets to revolve round the earth, in order to save our globe the trouble of a diurnal revolution, has already begged these questions. It is clearly established, on the contrary, that our atmosphere revolves in the same common motion, velocity, and direction with the earth; and that every thing in the world gyrates with it, and retains the same relative position. Thus, the "weighty stone" would follow the earth in its orbit, with an accelerated motion till it fell upon it; or, according to the position, magnitude, and impulse first given to it, would become a satellite to us. The motion of the cannon-ball is not analogous to the orbital motion, because its course is in a resisting medium. The Captain moralizes, and then proceeds:—

"As another proof that the earth is stationary, there are furious blowing streams, or currents of air, which the planets are carried in, (and which is the only rational, as it is the *natural cause* of their flying)—a region of excessive cold between the earth and the sun, which is evident by the tops of the mountains being perpetually covered with snow, by the poles being frozen, and by the cold that the aeronaut experiences three miles above the surface of the earth; and the sun's beams could not penetrate those intensely cold regions so as to impart warmth and produce vegetation, if the earth was not at rest, but on the contrary, flew 1133 miles a minute."

Well might we demand, "*dove diavolo avete pigliato tante coglionerie?*" It were better first to prove the existence of these Cartesian streams, and then tender them in evidence that the earth is stationary: not that the idea is at all original, it being a mere substitute for the *mung*, and the *hing* of infinite void, maintained by the Chinese followers of *Taou*. As to the reiterated exultations over the whirling rapidity of the orbital motions of planets, we beg to remind our author that *quick* and *slow* motions are mere comparative terms; and the circuit which occupies months or years may be called slow. The earth's absolute motion is only a diameter in eight minutes, and it is twenty-four hours making one revolution round its axis; it, therefore, has not the actual velocity which our measuring by miles would make us fancy. Thus the revenues of France appear enormous because reckoned in "francs," and so would the height of Etna were it merely computed in barley-corns.

We may now proceed to state that the COMPUTATIONS of the Commander, founded on the reveries of Mr. Brothers, determine the sun to be 900 miles in diameter, and 21,600 miles distant from us! This is a pretty exposition of the "Divine System," which would make the sun's parallax only the small quantity in arc of $9^{\circ} 28'$!! With his Hadley's quadrant, his chronometers must have been finely regulated on his own theory, by solar altitudes. The moon, it seems, is not of the magnitude so generally understood; by these new "computations," the diameter is *proved* to be 600 miles, and the distance 10,800; the parallax must consequently amount to no less than $18^{\circ} 26'$!! It is composed like the rest of the planets and stars, of a solid body of ice, formed from the division of the waters that ascended into the firmament on the second day of the creation! By the same optional rule,

the other bodies are disposed of, and it appears that no planet or star is more than 30' in diameter. On one of these masses he is severe:—

“Saturn being on the other side of the sun, from the peculiar construction of its crystalline mass of frozen water, presents, as it declines north and south of the equator, to the astronomer, who believes only through the telescope, and without a focus, magnifies what is indiscriminate, the appearance, as it certainly does, of a broad and thin ring; but which he calculates (though the planet in the course of its declination shows perfectly round for nine months together) to be detached from the body some two or three hundred thousand and *odd miles*, which is a wonderful distance through a telescope to have determined with accuracy; but as the observation has been taken with neither regard to ‘the logos,’ nor to the focus, it is about as true as—what if I should say as ‘*hocus pocus?*’”

We dislike to assert that even this sprightly ebullition has the crying defect of the rest of the book, viz. a want of originality; it is a palpable version of Serjeant Snuffle’s “*primus strokus sine jocus, absolutus est provokus.*”

The rotation of the earth is so repeatedly jeered, that the united authors would have figured well at the persecution of Galileo, who, however, was so unconquerably imbued with the truth which he had taught, that rising from his compulsory recantation, he fervently ejaculated, “*E gira nondimeno!*” But as a greater man than either Brothers or Woodley has refused assent to the Copernican system, we will demolish the dreams of the former by answering Tycho Brahé. In watching the diurnal progress of all the celestial bodies, it is obvious that there must be a general cause for the motion; and this cause may exist either in the immobility of the earth and the daily revolving of the heavens round it,—or they may be at rest, and we revolve round our axis every twenty-four hours. In either case, the rising and setting of the sun and stars will be presented to a certain degree in the same order; yet the revolution of the earth on its own axis is much more consonant with the comparison of appearances within our reach, and with the established laws of motion, than the revolution of the whole heavens. One of the strongest proofs of rotation is the figure of our globe, its polar diameter being considerably less than its equatorial one, a fact in which profound theory has been proved by actual measurement. In round numbers we may estimate the circumference of the earth at 25,000 miles; the space which every point of its equator must pass through, if the earth revolves on its axis, is about seventeen miles per minute. But this apparent velocity becomes absolutely insignificant compared with what the Commander’s crystalline bodies would have to fly at, on the other supposition: the sun would have to proceed twenty thousand times quicker than a cannon-ball, and the daily motion of Uranus must be twenty times greater than the sun’s, because it is about twenty times further distant from the earth than that luminary. These velocities are astounding, but they are snail-tracks in proportion to the rapidity with which the “fixed” stars must move to accomplish the same task: for if their distance be assumed at 200,000 times that of the sun from us, they must move over the space of 1,400,000,000 miles per second, in order to complete a revolution round the earth in twenty-four hours. Let us in addition to this consider the bulk of these different bodies, and a new question arises as to

the extraordinary powers necessary to retain them in their orbits, and counterbalance the amazing centrifugal force which they must possess. The observed rotatory motion of other planets, and various analogies support the conclusion, that the earth revolves daily upon its axis; while the annual motion is incontestably established by the exactness of the sidereal year, by the aberration of light, and by the periodical synodic aspects of the planetary spheres.

It would have been singular if our theorist had not treated us to a new system also of comets; but except in the poetical analogy of the smith's forge, his hammer has not struck out any luminous spark, nor are any of his assertions capable of proof. It must be admitted that in the present state of astronomy we are ignorant of the masses and amount of the forces by which these wanderers counteract the solar attraction, for we cannot observe them except during the time when they describe a very small portion of their orbits. But the gallant Commauder is utterly mistaken in supposing that the theory of their motions is not capable of unimpeachable demonstration; and in the instance of Encke, whom he has pointedly named, we not only differ from him, but fearlessly pronounce its discovery and orbit to be the proudest triumph of modern skill. This comet was first perceived by Miss Herschel, at Slough, in 1795, and though a mere misty blot, even to telescopic vision, is found to be amenable to the same laws of gravity which command dense bodies; and its course has been calculated with such exactness, by the illustrious Encke, that its periodical visits have proved the certainty of his theory. The comet of 1759 is remarkable on account of having been the first which was recognised as an attendant of the sun. Dr. Halley discovered the identity of the orbit it described in 1682, with those of two comets which had appeared in 1531 and 1607, and after making a vague estimate of the perturbations that it might sustain from the attraction of Jupiter and Saturn, hazarded the bold prediction that it would reappear in 1758, or the following year. The law of gravitation was not then universally admitted, and many astronomers continued to think that comets had no permanent connection with our solar system. Clairaut resolved to put the Newtonian theory to a decisive test by this erratic body, and after laborious inquiry, he announced that its passage through the perihelion of its orbit would take place about the middle of April, 1759. It appeared only about a month before the time predicted; and it is now known that if Clairaut had been possessed of more accurate data respecting the mass of Saturn, and had been aware of the existence of Uranus, the result of his prodigious computation would have been still nearer the truth. But our author shall speak for himself:—

“As to comets with a tail,—it is a tale indeed—100 millions of miles long. If my readers can imagine a small island floating round the earth in a stream or current of air, as do the sun, moon, and planets, having declination as they have, they may obtain a just notion of the great comet of 1811. As from a smith's forge—as from volcanos when the wind is high, so with the stream, before the body, blows the flame of a volcanic comet. Three years will about consume one, and as it becomes smaller by consumption, philosophers have conjectured that it is receding from the earth, whilst a

rapid declination makes them fancy that its orbit is eccentric. Neither Encke nor Halley ever calculated the return of one that came true—Encke is seven years out, and Halley, it is pretended, was one only, which is accounted for by the strong gravitation of Jupiter, and sometimes it is Saturn that leads us astray."

With respect to tides, our author is no less a despiser of Newton, than his brother officer, Capt. Forman, who rashly asserts the paragon of philosophers to be "continually committing the grossest blunders in consequence of neglecting the rules of geometry;" and that for his monstrous proposition on the gravity of a body resting on the earth's surface, he "richly deserves to be decorated with the cap and bells!" Commander Woodley flatly denies that the moon on one side, or centrifugal force on the other, have any thing to do with the circulation of the water any more than with the circulation of the blood. "The fact is," he adds, "the waters were made to circulate and to go to and fro as respecting the earth (which is stationary) from the beginning, that it should not become nauseous in time by stagnation, and for all the various purposes of life; for the fish to live in, and for man by industry to trade on." We are somewhat surprised that two navigators, of all others, should not have observed that the tides follow periodically the course of the sun and moon, especially as they must have heard old pilots, albeit unacquainted with theories, predict them with considerable truth, by the mere compass bearing of our satellite. It had long been suspected that the ebb and flow were produced by solar and lunar influences, but Kepler was the first who formed any conjectures respecting the true mode in which they act. What Kepler, however, only hinted "*extremis digitis*," has been completely developed and demonstrated by Sir Isaac Newton. His sublime mind, urged by an ardour at once inextinguishable and engrossing, not only supplied the principles for extending human knowledge, but also advanced far towards the solution of the most abstruse branches; still some were necessarily left more or less imperfect, till the multiplied and accurate observations of a long series of ages should complete the determinations. Thus has his incontrovertible theory of tides been assailed by jejune dabblers, who never suspect that were the globe entirely covered with water of uniform depth, its flux and reflux might be accurately computed and predicted. But when it is considered how greatly the attracting forces are modified by the rotation of the earth, and its irregularities of straits, continents, and islands, with other embarrassments, it is idle to expect that any general theory can assign all their precise effects. A clear practicable deduction is still easily available, in illustration, although it admits of various exceptions from local and other circumstances. The forces of the moon and sun's attraction are to each other as 51 to 10; the sum and difference of these numbers are 61 and 41; therefore the spring tides caused by the sun will be to the neap tides in the same proportion, or as 6 to 4; that is, the first are one third greater than the last; consequently, if the sun can raise the tide one foot eleven inches, the moon will raise it nine feet eleven inches, and both together, during the spring tides, about eleven feet and a half, but in neap tides only about seven feet and a half. It has been demonstrated that the tides increase as

the cube of the distances decrease, so that the moon at half her present distance would produce a tide eight times greater!

“ Attractive pow’r ! whose mighty sway
The ocean’s swelling waves obey,
And mounting upward, seemed to raise
A liquid altar to thy praise.”

The heterogeneous labours of the maritime speculator are crowned by a unique illustration of the sciences, in which, despite of the questionable qualifications held to be indispensable for so noted a discovery, he asserts his claim to having found the longitude. His method is on the principle of lunar distances, being a compound of the moon’s true place taken from the *Nautical Almanack*,—ay, the very ephemeris computed on the *erroneous* Newtonian theory,—and a rough estimate of her mean motion, from a given instant. Despising the investigations of those who have displayed the rare qualities of power of analysis, depth of judgment, and comprehensive knowledge,—he sets all minutiae at defiance, by omitting the correction for the effect of parallax and refraction, as well as the difference between the true and mean motion of the moon. Why did he not carry his theory of the planetary motions into practice; we should in this case have seen a lunar distance cleared of parallax, whose equatorial horizontal value, as we have shown according to their *reduced distance*, would be for the moon 18°, and for the sun 9°!

The reader will not be surprised, in this painful exposition, that the brilliant discoveries of aberration and nutation, the solar parallax as deduced from the transits of Venus,—and of the Moon and Mars from simultaneous observations in different latitudes, should be passed over without remark. In fact, the established truths on which the Newtonian theory of the celestial motions is founded, are either omitted or garbled for the promulgation of a system as mystified as the conundrums of Rabelais. Indeed, we have never met, in a similar number of pages, so many assertions without proofs, premises without conclusions, and conclusions without premises: and throughout is the leaden rule observed—

“ Decry all things, for to be wise
Is not to know, but to despise.”

We may now notice the mode in which the mighty Newton is elsewhere attacked, sometimes by men of high pretensions, and at others by smatterers, as is perceivable in running a scale from Godfrey Leibnitz down to Sir Richard Phillips. This pseudo-mathematical knight once called upon us, without any previous acquaintance, to discuss those errors of the philosopher which he “almost blushed to name;” and which were inserted in the *Principia* “to puzzle the vulgar.” He sneered with sovereign contempt at the “Trinity of gravitating force, projectile force, and void space;” and proved that, *all change of place is occasioned—by motion*,—“parturiunt montes!” did we need to be told this? He then exemplified the phenomena by placing some pieces of paper on a table, and slapping his hand down close to them, thus making them fly off, which he termed applying the momentum. All motion, he said, is in the direction of the forces; and atoms seek the

centre by a property which he calls "terrestrial-centripetation, and which causes universal pressure,"—but in what these differ from gravitation and attraction, "the deponent sayeth not." The majority of this phalanx have allowed speculation and conjecture to forestall observation and experiment: it being much easier to please the imagination than to satisfy reason,—to hatch theories than to ascertain results. This it was that decoyed Cardan and Albertus Magnus from the path of genuine science, and plunged them into unsubstantial labyrinths and fugitive mazes.

To the character of our matchless Prince of Geometers, these attacks are as the spots on the solar disc, to the glowing brilliance of the radiant orb of day. It is in looking back to the rude observations of the heliacal risings of stars in ancient times, and thence to the present astronomical system, that we are to estimate a portion of his powers. The geometry of the Greeks undoubtedly contributed to the discovery of the planetary laws by Kepler; and these, with the dynamic principles by Galileo, gave birth to Newton's sublime doctrine of attraction, which afforded demonstration to all others. By his supreme invention of the fluxionary calculus, he enabled a galaxy of profound mathematicians to pursue his physical researches, and develop the most abstract and abstruse effects of the simple cause which he had advanced. Amongst other labours, we may proudly quote the investigation of the planetary perturbations, or the refined doctrine of their reciprocal influences, by which every inequality of motion is ultimately redressed, and the permanence and stability of the solar system, incontestably established; a result which stamps the pre-eminence of modern science, and forms its *experimentum crucis*. Newton himself had not only discovered the cause and principle of the universe, but, by the balance of an exalted geometry, ascertained its law and intensity. His principle being then assumed by other philosophers, the calculated phenomena of nature were found to agree with observation, by which a conquest far above the circle of mere geometric truths was obtained. Still the retardation of planetary motions sorely perplexed the astronomical world; and the knowledge requisite for their developement was of tardy growth. But the veil is at last withdrawn, and the Newtonian theory of the mysterious influence of attraction, successfully carried to an extent beyond the warmest anticipation of its discoverer. "These inequalities,"—says La Place, the most gifted follower of Newton,— "seemed formerly inexplicable by the law of gravitation; but they are now one of its most convincing proofs. Such has been the fate of this brilliant discovery, that every difficulty which has arisen, has been for it the subject of a new triumph."

In whatever degree of national exultation we may indulge at having produced this father of Inductive Science, the world at large has united with us in venerating him; and in France especially, the noblest estimate of his merit has been made. Bailly, whose glowing portrait of the philosopher is stamped with skill and dignity, remarked, that "as the empire of Alexander was divided among his successors; so the sceptre of Newton passed into the hands of Clairaut, Euler, and D'Alembert;" and their labours, perfected by those of La Grange and La Place, have established the empire of their illustrious founder, and

reared an imperishable trophy to his fame. In thus abandoning the airy and hypothetical notions of Descartes, and perpetuating the immutable truths of one whom Halley considered a near approach to the divine intelligence, the names of the continental geometricians must for ever be associated with that of their great prototype, in the history of physical astronomy. Yet the services thus rendered to science by the disciples, eminent as they are, are not to be put into competition with those emanating from the vast genius of their master; whose mind, superior to common barriers, and equally distinguished for extent and accuracy of intellect, not only discovered the existence of a solid principle, but even created the calculus by which alone it could be demonstrated, and all its difficulties vanquished.

Without anticipating the share of renown which may be allotted to the joint authors of the "Divine System of the Universe," upon which we have somewhat unwillingly been led to expatiate longer than we intended, we may safely assert, that the name of Newton will be pronounced with rapturous enthusiasm, when the more fleeting glories of England may have faded, and her monuments of marble and of brass become crumbled in the dust.

THE SOLDIER'S BRIDE.

FROM THE "CHAPEL OF THE MIDNIGHT MASS," A GERMAN LEGEND.

BY MRS. LAWRENCE.

FROM war's far plains where roams my lover,
On sleep's soft wings his image flies;
And Adolph's form bends o'er my pillow,
And charms to rest my weary eyes.

Blest visions o'er my slumber stealing,
Gild with pale light the midnight's gloom;
To hope and fancy's view revealing,
More bliss than e'er in life may bloom.

His joy-winged step, his spurs' light ringing,
His sabre's clank I seem to hear,
And vows of love and rapture blending,
Breathe softly on my dreaming ear.

Soon the mild dawn of peace returning,
Shall bid our bridal morn arise,
And Adolph's radiant smile of gladness,
Shall light to bliss these tear-fraught eyes.

Beam! beam, blest stars! on that bright morrow,
Ere grief and care our fates divide;
Ere hope expire in doubt and sorrow,
And death, not love, have claimed the bride.

SURVEY OF THE WEST COAST OF AFRICA IN 1825-6.*

HAVING completed our survey of this harbour, (Port Lopez,) and made some necessary repairs, we proceeded to the northward. The coast for a considerable distance from the Cape is extremely fertile, but apparently has not many inhabitants, as we only observed two small villages along shore for many miles. As we approached Sandy Point, the country became very low and thickly wooded to the water's-edge, the interior rising gradually to rich fertile hills. Sandy Point or Corner forms the southern entrance to the river Gaboon, off which place the sea is constantly bubbling and agitated in consequence of the shoalness of the water and the bottom being very foul. Having rounded this corner, we made Cape Clara, which forms the northern point of the river, and shortly after came-to, when a boat of European structure came alongside, but the head man was so thoroughly drunk, we could obtain no information from him: it appeared, they were on their way to Cape Lopez, and that the boat had formerly belonged to a Portuguese vessel, whose crew had been murdered somewhere in this neighbourhood.

On the following day, we sent two boats away for the purpose of sounding the entrance to the river, while the ship stood across to the westward, but the sea breeze falling compelled us shortly to anchor, when we observed two Spanish brigs lying a little higher up on the southern shore. In the morning, some large canoes with natives came on board, who brought a very seasonable supply of poultry and vegetables. Upon the sea breeze setting in we got under way, and entering the river, observed the two brigs standing out under all sail: we afterwards heard they had been trading for slaves and quitted immediately upon our approach, fearing we might deprive them of their illicit cargo. As we were proceeding up the river to Parrot Island, we passed an English brig at anchor. Those who have never beheld our national colours floating proudly in the breeze, far from their native gales, cannot conceive the mingled feeling of pride and pleasure with which it fills the bosom: to see that flag—the envy and terror of the world—receiving homage and respect from every nation of the universe, is a sight that makes the Briton proud of his country, and boastful of her fame: even the savage African pays the respect of fear to that well-known emblem of the ocean's queen; he has learnt that honour, courage, and integrity, are always found beneath the staff which supports it. Let none, therefore, who were born under its protecting shade, forget what they owe the soil where it was first planted, for the shield of Britannia covers her sons wherever fate or inclination may lead them; and the best safeguard a man can possess in a foreign country, is the name of—*Englishman!*—But to return from this national digression.

On the morning of the following day, several canoes came on board to barter. These people were from a town situated on the north-side of the river, called King Glass Town; they appeared extremely docile and very desirous of making trade with the English, a character quite opposite to that which report had given them, or rather the jealousy of

* Continued from page 193.

their neighbours to the southward; in fact, many of them had certificates from different masters of vessels, both English and Portuguese, wherein they mentioned having left with them articles of barter to a very large amount, which on their return were faithfully given up or accounted for, and as they have great intercourse with our traders, many of them speak English with some fluency. We anchored near the brig which lay just off the town where the British colours were hoisted—having procured an ensign from some vessel, and not being particular—numerous canoes immediately came on board well stocked with fruit, fowls, &c. and through the master of the brig, who possessed some influence, we obtained a quantity of goats and vegetables, which are, otherwise, very difficult to procure in consequence of their scarcity. During the day, a man employed in the watering-party lost a shirt that he had been washing, and laid out to dry, and which he suspected to have been stolen by one of the natives. Upon the officer informing the king of this, he immediately had a consultation with his Fiteesh, and by its assistance, as he informed us, the man was shortly discovered with the stolen article in his possession: his majesty gave orders for him to be publicly whipped, after which the shirt was returned.

The ladies came on board in great numbers, never having seen "A man-of-war-ship," as they expressed it, before. These women are possessed of much natural grace and beauty (*noir*) with, in some instances, shapes that would make the Venus de Medicis blush at her own deformity: every facility was given to form a correct idea of their symmetry, as the everlasting fashion amongst the ladies of King Glass Town, has been founded upon the oft quoted passage that,

"————— Beauty
Needs not the foreign aid of ornament;
But is when unadorn'd, adorn'd the most!"

What a whimsical young gentleman that Love is! and how unfairly he is charged with directing his darts only at the heart of his victims: could we, as the Irishman says, but have *seen* these beauties in the *dark*, many of us would have been subdued by their tender blandishments, but the eye resisted the well-shot arrows of their sable cupid, and as that is at least the high road to the heart, he gave it up in despair. These women were the first we had met entirely free from a disease to which nearly all the female negroes are subject, and which they rather aptly call the *craw-craw*. But as a description of this complaint might offend the refinement of an English reader, I shall content myself by merely mentioning it as a fact connected with the inhabitants of this coast. Polygamy is here allowed at discretion, and his majesty is considered extremely moderate, as he only possesses *fifty* lawful wives. The king's name is Qna Ben, and he appears a very popular monarch, as all his subjects speak in very high terms of his justice and other royal virtues.

Whilst taking a stroll through the town with two or three hundred people at my heels, they led me to a large building which they called their prison. Here I saw a miserable-looking mortal stretched on his back upon the ground, with a small spar of wood extending his arms, and another his legs; this was done by fastening the wrists and insteps to the end of the stick at their utmost stretch, which placed the body

in exactly the position of a person crucified upon the cross of St. Andrew, and deprived him of the power to move in any direction. I was informed that he had been lying in this posture for many weeks, and as food was given him daily, life still remained; a mass of corruption, to be slowly destroyed by the animals of too disgusting a nature to mention, which were actually devouring the living flesh from his bones. Sense enough still remained to feel the constant torment of his active destroyers, and a hollow groan occasionally burst forth as his lacerated body writhed beneath the keen agony of their venomous bite—

“ It was as if the dead could feel
 The icy worm around them steal,
 And shudder, as the reptiles creep,
 To revel o'er their rotting sleep,
 Without the power to scare away
 The cold consumers of their clay !”

I shuddered with horror as I gazed on this victim of cruelty, and would gladly have discharged my pistol at his head, to end at once his lingering torments. I had frequently heard the effect produced on the mind by a spectacle of extreme human suffering, but never until that moment fully experienced it. No imagination less powerful than that which delineated the horrors of Frankenstein, could possibly describe the picture of this mortal *mouldering in life*. The soul appeared just clinging to the rotting body, until it became too pestiferous for the pure essence to dwell in; the eye seemed unwilling to contemplate the scene, and turned or fell from it, while a kind of giddiness overcame the sight, which gazed as we do upon objects in a dream: I felt also a kind of sickness or loathing, with an inclination to leave the spot without the power, and I should have remained there, had not the natives, perceiving, I suppose, the excitement under which I laboured, hurried, nay, almost carried me away. Is it not strange that these savages, debased and ignorant as they are, should have discovered a greater refinement upon torture than the more enlightened states of Europe? That prototype of hell, the Inquisition, could never boast of so sublime a one in the list of its numerous and ingenious devices, to extort confession from the racking body! Is it not still more strange, that man will inflict a punishment of greater suffering upon a fellow creature, than upon the brute which is subject to his will, for not one of these savages, who with unfeeling apathy, stood an unconcerned spectator of this human being's anguish, would have seen any other living thing in the same situation without at once ending its existence as an act of humanity! They told me that this victim of barbarity had committed an offence of great magnitude in that country. It is one of their customs, whenever a person of any note dies, to bury the whole or greater part of his property with him, under the impression that he may find it serviceable in the other world; this man had been discovered robbing one of these graves, acting doubtless upon a very natural and sensible principle, that what is good for the living is of no use to the dead; but it being considered a most atrocious crime amongst these people, the punishment is that which I have attempted to describe. Before our leaving, I was rejoiced to hear that he had been released by the hand of death, a more merciful one than that which kept him there.

The natives came off in great numbers upon hearing of our intended departure, bringing parrots, honey, plantains, bananas, and every description of provision, all of which were much in request, and a great deal of trading took place; when having completed a survey of the river, and recruited our stock of wood and water, we weighed and stood along shore to the northward. The next place we made was Cape Esteiras, which forms the southern entrance to Corisco Bay; we then came upon the two Islands of Corisco, where several canoes attempted to come on board, but having a fresh breeze, and not wanting them, they could not gain the vessel. These people are reported as being very unfriendly to white faces, but in all probability, like nearly all upon the coast, they are not so towards any benefit to be derived from them. This it is in Africa, as well as Europe, that procures politeness, and the savage has now sense enough not to eat you, if he can profit more by letting you remain unchewed; which may be considered at least one step towards civilization.

We anchored just off Corisco Bay, and shortly afterwards one man in a canoe, who I suppose thought himself a hero, came alongside from the town near Cape Esteiras. This fellow brought some plantains and fruit to dispose of for brandy or whatever else he could get: bringing his stock on board he commenced bargaining; but whilst in the middle of his dealings the boatswain piped to supper, upon which the Nigger became so much alarmed, that he immediately made a spring from the place where he stood, clear over the ship's side into his canoe, and commenced pulling with all his might ashore, having left his stores behind him, for the benefit of his customers.

Leaving the ship at anchor in the bay, on the following morning I was sent in a boat for the purpose of track surveying the southern shore, and accordingly stood in for the entrance to the river Moondah: about the middle of the day we anchored for dinner near one of its banks, beneath the shade of some friendly plantains; during our meal we observed the Barracouta under way, trying to make the mouth of the river. I continued my work round the southern point, coming to anchor at dark a quarter of a mile off the land. Numerous lights were visible during the night along the coast, which we could not help wishing had been a little nearer, or on a friendly shore, but the reported character of these people was so bad, that I considered it advisable not to trust them; they were described as very ferocious and treacherous, with all the uncultivation of their cannibal forefathers: we coveted the fires more, as the rain came down in torrents, setting at defiance all tarpaulines and blankets, while the thunder was playing a kind of double bass solo, to the fantastic gambols of the dancing lightning. Being wet through, we found it necessary to keep constantly mixing the intrusive element with divers portions of a more grateful and stimulating fluid. The morning brought the cheering sun with his genial rays, to absorb the superabundant moisture from our well-soaked bodies. Having demolished sundry etceteras, we continued along the coast to the westward with a favourable breeze, which enabled us to finish a considerable distance by noon, when we came to off a small village. Several canoes immediately came alongside with fowls, fish, yams, &c. for which they wanted in exchange tobacco, the only thing they would take or appeared to have the least value for. The

men in my boat had but little of this article to spare, so tried to persuade them to take biscuit, but they refused to give a single plantain for any quantity, and would not even eat it when offered them gratis; while they readily gave a couple of fowls and a large hunch of yams for an inch or two of pigtail. Finding we could do no business with them, they were about going away with their goods, when one of our men happened to take the tobacco from his mouth which had probably been there, performing all sorts of evolutions for the last *three hours*; immediately this was observed, one of the natives seized it with the utmost avidity, and stopped the sailor's exclamations by throwing a pair of fowls at him; he then jumped into his canoe, and we saw him bearing off the luscious morsel with the greatest delight: this ended the traffic, as they were apprehensive we should be offended at the good bargain which their liquorish countryman had made for himself, consequently they all escaped with the utmost dispatch, when we got under way towards Cape Esteiras. This cape is formed perfectly round at its head, with an extensive reef running some distance out; we came to near this place and went on shore, where we found plenty of good fresh water, and took advantage of it to fill our casks, which by this time began to exhibit symptoms of *flatulency*; we also procured a stock of wood, another very plentiful article at this place. Having completed these domestic arrangements, we went off to the boat, which I had pulled about a quarter of a mile from the shore, then anchored and set the watches.

In the morning at daylight, we observed the Barracouta under way eight or nine miles to the northward, so immediately made sail and arrived on board at noon. We continued working about the islands of Corisco during the greater part of the day, when we steered towards the Moondah, and at sunset came to just at the mouth. This river is about three miles broad at the entrance, but we found the water so shallow that we did not consider it worth while to continue our examination; the banks on each side appeared thickly wooded, and, as far as the eye could see, very low, with the exception of a few small hills to the right; neither could we observe the least appearance of inhabitants. We next proceeded along the north-east side of the Bay, keeping about two miles from the shore, until we came to off Musquito Islands; these are a couple of small islands, situated on the north side of the bay near the river Mooney or Danger; they are each about a mile and half in circumference, surrounded by very shoal water. We sent a boat to procure soundings at the entrance of the river, which they failed in doing with forty fathoms. The natives of the Mooney were reported as being very unfriendly, and particularly inimical to Europeans; and as the inhabitants of all the islands give them the same character, and will not even allow them to land, I suppose it is not without foundation. Whilst employed about these islands the natives were constantly coming on board, and we always found them very docile and passably honest; this was a fortunate occurrence, as they supplied us plentifully with every description of fresh stock and vegetables, which we stood greatly in need of at this time, as the scurvy had appeared in a slight degree amongst the crew.

Whilst the Barracouta remained in this Bay, I was dispatched with the pinnace and three days' provision, to track survey the coast to the

northward; the country during the first day was beautifully picturesque, presenting a most pleasing diversity of hill and vale. Towards evening, whilst running along shore, a canoe put off, having on board some bananas and other fruit; but in consequence of the unfavourable reports concerning these people, and my party being small, I was cautious of holding any correspondence with them; but this fellow being alone, I was induced to allow him to come along side with his fruit and then immediately sent him away. When it was observed from the shore that I allowed this one to approach, numbers instantly put off; but not wishing to be detained if their intention was friendly, or to fight if it was otherwise, I got the boat under way before they had come very near. Whether the natives interpreted this as an act of timidity I know not, but they immediately gave way after us in the most threatening manner, being joined by others from all sides, until they mustered nearly thirty, with five or six men in each, armed with spears and clubs; as they gained upon us rather quickly, we heard an occasional whoop, which left little doubt in the mind of any, but that their intention was hostile. I therefore allowed one which was far a-head of the main squadron, and very eager in the pursuit, to come rather close, when I stood up in the boat and fired a pistol over their heads: this stopped their progress for a moment, but soon recovering the surprise which it occasioned, they beckoned to the others and again commenced the chase. Having made every preparation for extremities, I next, as they were bearing down upon us with great rapidity, fired a musket quite close over them, the sound of which produced quite a magic effect. There is something unpleasant, as Byron and many other people say, in the whiz of a ball just by your ear; and these Africans appeared to think so without being indebted to him for the idea, for half of them immediately pulled ashore with as much or more expedition than they had just been pursuing us, and were very soon followed by the remainder: this was a very great relief to us, and I much applauded the cowardice of these savages, as it prevented the necessity of spilling their blood for our own preservation.

Having thus got rid of these dangerous visitors, we pulled on for some distance, and then anchored for the night about a quarter of a mile off shore. I invariably, when sent from the ship in command of a boat, was particularly cautious not to allow the natives to approach in any numbers: and also at night to lie at a convenient and safe distance from the land. These precautions I would strongly recommend to all young officers employed in this description of service, on a coast where the inhabitants cannot be depended upon. Precaution never is, nor will be mistaken for fear, but will serve rather to recommend an officer in the opinion of a discerning superior. What merit should we have obtained by a rencontre with these ignorant savages through a reckless carelessness, or defiance of their power to injure us? Had we under such circumstances succeeded by destroying one half of them, in compelling the other to retreat, little glory would have attended the exploit, and much blame, if by moderate caution it could have been avoided. But on the contrary, if their unsuspected or treacherous attack was successful, the same paper that told the melancholy tale, would pass a censure upon the memory of him whose imprudence had led to it. An officer in command has a great responsibility in this situation; he must not forget that it is not his own safety alone, but many valuable lives

are in his keeping: this reflection should deter him from any rashness or thoughtless contempt of the almost unarmed natives, for numbers will prevail against the most determined and heroic bravery, more especially when surprise is enlisted on the part of the assailants.

I am sorry to say this feeling of contempt was too frequently manifested by many of our young gentlemen, a melancholy instance of which I shall take this opportunity to relate, as it happened on the eastern coast during the early part of our expedition. Whilst off the south-west side of Madagascar, a boat was sent away for the purpose of surveying under the command of a Mr. Bowie, an old passed midshipman, with a youngster to assist him, named Parsons. Having done some work and the dinner hour being near, Mr. Bowie directed the men to pull for a small uninhabited island, about three or four miles from the main (Madagascar), which he thought would be a pleasant situation for that purpose; and accordingly, as the sea was quite calm, had the boat's nose run upon the beach. A spit of sand, extending from a point of this island, was noted for beautiful shells, which induced Mr. Bowie, as soon as the men had dined, to dispatch them all for the purpose of collecting, whilst he and his companion remained in the boat, with the intention, it is imagined, of improving their sketch of the forenoon's work, which was our usual practice. The men soon lost sight of the boat behind a foreland, and having arrived at their destination, commenced all sorts of pastimes, not, however, forgetting the intention of their journey, when having made a plentiful collection, and their time being nearly expired, they set out on their way back, but instead of retracing their steps, a kind of sailor's whim, without a reason, induced them to return by the other side of the island. When they came within sight of the boat, neither of their officers were visible; this did not, however, produce any alarm, as they concluded them to have rambled a short distance into the woods, but upon coming to the spot, their surmises were quickly changed into dreadful certainty. The first object presented to their sight was Mr. Bowie, lying at the stern, grasping a musket in his hand, and pierced by numerous spears that still remained in the bleeding wounds they had made: a pool of yet warm blood told at once the vital sources which had been opened, and left no hope of life. An exclamation of horror burst from all, and their rude mirth was suddenly changed into sounds of grief and lamentation: but they were called from the contemplation of this sad spectacle to another of an equally affecting nature, for a few yards from the boat was seen the body of poor Parsons just at the edge of the water, washing slowly on the shore, and then rolling gently back, with the receding surf. They instantly drew it on the beach, when the numerous wounds with which his slight frame was covered, gave out their crimson tide with redoubled violence:

“ And, like a withered lily, on the land
His slender frame and pallid aspect lay.”

The bloody work had been too well done;—they were both dead!

A consultation was held, whether to go in pursuit of the blood-thirsty savages, and take revenge upon them for their murdered officers, or return to the ship and report their melancholy fate? After a little time the latter course was resolved upon, when they laid the cold remains at the bottom of the boat, and rowed in mournful silence and with heavy hearts on board. When we saw the bleeding, lifeless

bodies of our poor messmates hoisted up the side, every bosom burned for vengeance, and a universal cry was raised to go on shore and annihilate every soul that could be met with for this inhuman act. But our worthy and prudent Captain checked in some measure this feeling for revenge, by representing how certain it was that we must destroy the innocent many with the guilty few; we were, therefore, only left the melancholy satisfaction of mourning over the memory of our friends, who were thus suddenly torn from us, and those to whom they were even *more* dear.

We were since informed that these murderers, after having destroyed the two officers, had gone in pursuit of the unarmed crew, with the intention of making them also victims to their cruelty, when they would have returned and plundered the boat; but as a kind Providence ordained it, the before-mentioned whim induced them to take a different route for their way back, and thus avoid the fate which awaited them. They gained, however, nothing but the blood of their victims, and they probably saw the boat which was to have been their reward, on her way to the ship; nay, it even appeared that ample revenge was taken upon the performers in this tragedy, for upon the case being reported to Radama, the King, who was very friendly to the English, he vowed that all in the neighbourhood should be put to death, which order we afterwards learned was most strictly obeyed, and as his reign is quite despotic, it is not at all incredible. The spot where this heart-rending occurrence took place has since been known as *Grave Island*, while the place from which the perpetrators came has received a name in accordance with their nature—*Murderers' Bay*; and they are thus called in our charts.

The length of this digression may, I fear, require some apology,—at least if there be any whose feelings are not interested by the detail. In extenuation, I must confess that Madagascar is not likely to be met with in a *Survey of the Western Coast of Africa*; but I trust that the kindness of my readers will indulge me in this opportunity to record the untimely death of two young and promising brother officers; they have

“————— No sculptured urns,
To mark the spot where earth to earth returns.”

neither do I know any that would be so immortal, as the pages of this highly interesting Journal. The sons of Britain will for ever refer to it, as a faithful and familiar memorial of their heroic forefathers; while the friends of our unfortunate companions may read their epitaph on the shelf which contains this volume in the library of the British Museum.

I now return to the islands of Corisco, from whence we took our last departure; they are situated at the entrance of the bay, and are very fertile in appearance, and productive in reality. The largest is called Great Corisco, being about three miles long by two and a half broad; at the south end is a populous town, with a very good anchorage a mile and a half from the shore, in seven fathoms water. There are, however, several patches of rock in the neighbourhood, which being slightly covered above, and surrounded by very deep water, renders them extremely dangerous, making it requisite for vessels to take every precaution when in their vicinity. The Bay of Corisco is of great ex-

tent, being thirty-five miles north and south from Cape St. John to Cape Esteiras, and fifteen from the island to the river Moondah. The surrounding shores of this magnificent harbour are so thickly wooded, that the eye can trace nothing but one continued mass of verdure, while the numerous islands with which it is studded, rise from the sea like emeralds, so rich is their green lustre down to the water's edge.

Whilst up the river Gaboon, we heard many reports concerning the treachery of these islanders, but as we did not witness it in a single instance, we were inclined to think more favourably of them. Power certainly is a great protection against violence, and our formidable appearance probably was a better safe-guard than the faith of the savages. We found many of these people speak English, and an instance was related to us of their kindness and humanity, which exalted them greatly in our estimation. They informed us, that a few months before our arrival, a Portuguese slaver, or pirate, was lying at anchor in the bay, when an English schooner arrived to trade for ivory, wax, &c. Europeans meeting in this out of the world sort of place, naturally led to inquiries; an occasional visit followed, which soon terminated in intimacy, when the Portuguese took an opportunity of inviting the master and mates of the English vessel to dinner. It is supposed, but no authenticated statement remains, that after plying their unsuspecting guests with wine until they became intoxicated, they basely murdered them in cold-blooded treachery. This done, they went under some pretext on board the schooner, and waiting for a favourable moment, attacked the unprepared crew, who having no means of defence, became an easy and almost unresisting prey to their well-armed and blood-thirsty destroyers. During the short but murderous struggle, one of the boys contrived to jump overboard, and whilst swimming for the shore, met the vessel's boat coming off with another boy in her; he succeeded after some time in attracting the attention of his shipmate, who instantly picked him up, by which his own life was saved, as, had he gone alongside, the work of butchery would most probably have been ended by taking the life of this poor boy! they instantly pulled with all the strength fear had left them for Great Corisco. The relater of these particulars showed us a description of the occurrence, which had been written by the master of a trader, who shortly afterwards arrived and took them home. They had both attached their names to this document, which contained many expressions of gratitude for the kindness they had received from the natives. After these Portuguese savages had destroyed the unarmed victims, whom their cowardice led them to fear, they plundered the vessel of every thing valuable, and run her on the rocks, where part of the wreck still remained in evidence of their guilt. Our cruisers were soon made acquainted with this act of atrocity; but it does not appear that they ever succeeded in taking vengeance upon the assassins; yet it is difficult to imagine that they will ultimately escape the fate which they deserve. That hand which punishes unseen will not allow such iniquity to pass, and although they may for a time escape the pursuit of justice, and even leave this world without the pangs of an upbraiding conscience, yet mercy will shun them in the next, and leave them to everlasting torments and despair.

H. B. R.

(To be continued.)

REMINISCENCES OF A SUBALTERN.

NO. VI.

BADAJOS was laid siege to for the second time on the 30th of May 1811; on that day, the investment of the town on the left bank of the Guadiana was completed, as was also that of the fort of San Christoval on the right bank; and the trenches before both were opened that night.

This was my first siege, and the novelty of the thing compensated me in some degree for the sleepless nights I used to pass at its commencement; but habit soon reconciled me, and I could sleep soundly in a battery for a couple of hours at a time. Nothing astonished me so much as the noise made by the engineers; I expected that their loud talking would bring the enemy's attention towards the sound of our pick-axes, and that all the cannon in the town would be turned against us, and in short I thought every moment would be my last. I scarcely ventured to breathe until we had completed a respectable first parallel, and when it was fairly finished, just as morning began to dawn, I felt inexpressibly relieved. The seventh division was equally fortunate before San Christoval.

As soon as the enemy had a distinct view of what we had been doing, he opened a battery or two against us with, however, but little effect, and I began to think a siege was not that tremendous thing I had been taught to expect; but at this moment a thirty-two pound shot passed through a mound of earth in front of that part of the parallel in which I was standing, (which was but imperfectly finished,) and taking two poor fellows of the 83rd (who were carrying a hand-barrow) across their bellies, cut them in two, and whirled their remnants through the air. I had never before so close a view of the execution a round shot was capable of performing, and it was of essential service to me during this and my other sieges. It was full a week afterwards before I held myself as upright as before.

On the 2nd of June, our batteries opened against the Castle and San Christoval; the communication between the latter and Badajoz was covered by a *tête du pont*, that protected the Roman bridge, which terminates at the Elvas gate. Our fire on the left bank commenced with a good deal of brilliancy, but the brass guns were inadequate to the task they had to perform, and after being a short time at work, became so hot as to be useless. The artillery men were occupied for several hours throwing buckets of water over their barrels, in order the sooner to render them fit for work. The cannon of the enemy were, it is true, of the same description, but their train was more numerous; and besides they could, without much trouble, disarm such of their batteries as were not opposed to ours, and thus, by a continual interchange of guns, overpower our fire, while we were obliged to work with the same set: this they did, and with considerable effect too, and our casualties increased in proportion.

The touch-holes of several of the cannon melted away, and became so large, that they were unserviceable; others were rendered useless by being plugged up with the enemy's shot; and by ten o'clock each morning, our line of batteries presented a very disorganised appearance; sand-bags, gabions, and fascines, knocked here and there; guns flung off their carriages, and carriages heaten down under their guns. The hoarded platforms of the batteries, damp with the blood of our

artillery-men, or the headless trunks of our devoted engineers, bore testimony to the murderous fire opposed to us, but nevertheless every thing went on with alacrity and spirit; the damage done to the embrasures was speedily repaired, and many a fine fellow lost his life endeavouring to vie with the men of the engineers in braving dangers, unknown to any but those who have been placed in a similar situation.

It was on a morning such as I am talking of, that Colonel Fletcher, chief officer of Engineers, came into the battery where I was employed; he wished to observe some work that had been thrown up by the enemy near the foot of the Castle the preceding night. The battery was more than usually full of workmen repairing the effects of the morning's fire, and the efforts of the enemy against this part of our works were excessively animated. A number of men had fallen and were falling, but Colonel Fletcher, apparently disregarding the circumstance, walked out to the right of the battery, and taking his stand upon the level ground, put his glass to his eye, and commenced his observations with much composure. Shot and shell flew thickly about him, and one of the former tore up the ground by his side and covered him with clay; but not in the least regarding this, he remained, steadily observing the enemy. When at length he had satisfied himself, he quietly put up his glass, and turning to a man of my party who was sitting on the *outside* of an embrasure, pegging in a fascine, said, "My fine fellow, you are too much exposed; get *inside* the embrasure, and you will do your work nearly as well." "I'm almost finished, Colonel," replied the soldier, "and it isn't worth while to move now; those fellows *can't* hit me, for they've been trying it these fifteen minutes." It was the last word he ever spoke! He had scarcely uttered the last syllable, when a round shot cut him in two, and knocked half of his body across the breech of the gun. The name of this soldier was Edmond Man; he was an Englishman, although he belonged to the 88th Regiment. When he fell, the French canuoniers, as was usual with them, set up a shout, denoting how well satisfied they were with their practice!!

On the right bank of the river, the operations against San Christoval proceeded more rapidly than those against the Castle, and the loss was proportionable to that sustained by the troops employed on the left of the Guadiana. Amongst the officers who fell, was Lieut. Hunt, of the Artillery; he was a young man of much promise, and had distinguished himself by his zeal in the batteries.

One evening while we were occupied in the usual way in the trenches, a number of us stood talking together; several shells fell in the works, and we were on the alert a good deal in order to escape from them. A shell on a fine night at a *distance* is a pretty sight enough, but I, for one, never liked too near a view of it. We were on this night kept tolerably busy in avoiding those that fell amongst us; one, however, took us by surprise, and before we could escape, fell in the middle of the trench; every one made the best of his way to the nearest *traverse*, and the confusion was much increased by some of the sappers passing at the moment with a parcel of gabions on their backs. Colonel Trench of the 74th, in getting away, ran against one of those men, and not only threw him down, but fell headlong over him, and sticking fast in one of the gabions, was unable to move. As soon as the shell exploded, we all sallied forth from our respective nooks, and

relieved Colonel Trench from his awkward position. "Well," said Colonel King, of the 5th, "I often saw a *gabion* in a *trench*, but this is the first time I ever saw a *Trench* in a *gabion*." Considering the time and place, the pun was not a bad one, and made us all laugh heartily, in which Colonel Trench good-humouredly joined.

Not long after this, a round shot carried away the arm of a soldier of the 94th. Doctor O'Reily, of my corps, happening to be the nearest medical man, was awoke out of a sound sleep by his orderly serjeant, and having examined the stump, amputated the fractured part. O'Reily was one of the most eccentric, and at the same time one of the pleasantest fellows in the world. He delighted in saying extraordinary things in extraordinary places, and it was amusing to those who knew him well, to see his countenance, after saying something out of the common way before a stranger. In the present instance, after having wrapt his boat-cloak about him, and settled himself in the same position he had been in before he performed the operation on the 94th man, he, with the most profound gravity of manner, asked the serjeant if he recollected the state in which he had found him? "Indeed, Sir," replied the orderly, with a broad grin, "your honour was fast asleep, *snoring* mighty loud." "Well then, Sir, if you return here in five minutes, in all human probability you will find me in precisely the same situation," and he immediately fell asleep, or feigned to do so.

On the evening of the 5th, I was sent in advance with a covering party of forty men; we were placed some distance in front of the works, and as usual received directions to beware of a surprise. Our batteries were all armed, and a sortie from the garrison was not improbable; the night was unusually dark, and except an occasional shell from our mortars, the striking of the clocks in the town, or the challenge of the French sentinels along the battlements of the castle, every thing was still.

A man of a fanciful disposition, or indeed of an ordinary way of thinking, is seldom placed in a situation more likely to cause him to give free scope to his imagination, than when lying before an enemy on a dark night; every sound, the very rustling of a leaf, gives him cause for speculation: figures will appear, or seem to appear in different shapes; sometimes the branch of a tree passes for a tremendous fellow with extended arms, and the waving of a bush is mistaken for a party crouching on their hands and knees.

The certainty that several batteries may be opened upon you at "sight" without "advice" being given of it, or that some hundreds of chosen troops may rush upon you with fixed bayonets, is an unpleasant idea, and the knowledge that those fellows are paid by the governor *according to the way they do their work*, tends but little to tranquillize you, or give you a turn for *sleep*. Expecting both, or either of those things, it is not to be wondered at, that a man should be a little on what the French call the *qui vive*, and I don't know why it was, but I could not divest myself of the idea that an attack upon our lines was meditated. I cast a look at my men as they lay on the ground, and saw that each held his firelock in his grasp, and was as he should be; half an hour passed away in this manner, but no sound gave warning that my suspicions were well founded. The noise of the workmen in the trenches lessened by degrees, and as the hour of midnight approached, there was, comparatively speaking, a death-like silence.

I went forward a short distance, but it was a short distance, for in truth—to say the least of it—I was a little “hipped.” I even wished the enemy would throw a shot or two against our works to give a fillip to my thoughts. Heavens! how I envied the soldiers, who slept like so many *tops*, and snored at least as loud as Dennis Balruddery, when he *awoke* the congregation of Parson Snufflebags.—I went forward again, but had not proceeded more than about one hundred paces when I heard voices whispering in my front, and upon observing more minutely in the direction from whence the sounds proceeded, I saw distinctly two men. The uniform of one was dark; the other wore a large cloak, and I could hear his sabre clanking by his side as he approached me.

At the instant, I do not know *what* sum I would have considered too great to have purchased my ransom, and placed me once more at the head of my men. I need scarcely say that I regretted the step I had taken, but it was too late. The figures continued to advance towards the spot where I was crouched, and were already within a few paces of me: I did not know what to do, I dreaded remaining stationary, and I was ashamed to run away,—there was not a moment to be lost, and I made up my mind to sell my life dearly. I sprang up with my drawn sabre in my hand, and called out as loud as I was able, (and it was but a so-so-effort,) “Who goes there?”—My delight was great to find in place of two Frenchmen, (the advance, as I expected of several hundred,) Capt. Patten, of the Engineers, attended by a serjeant of his corps; he held a dark lantern under his cloak, and told me he had been on his way to reconnoitre the breach in the castle-wall, but that he thought it as well to return to the first covering party he should meet with, in order to get a file of men which he proposed taking with him to within a short distance of the breach. I was just then in that frame of mind, from my own little adventure, to approve highly of his precaution, and I gave him a couple of what our fellows (the Connaught Rangers) used to call, lads *that wern't easy*, or, to speak without a metaphor, two fellows that would walk into the mouth of a cannon if they were hid to do it.

Previous to this I had passed an uneasy night, but I was now filled with much anxiety for the fate of Capt. Patten, and my own two men. They had left me about a quarter of an hour, when a few musket-shots from the bastion nearest the breach, announced that the *reconnoissance* had not been made unnoticed by the enemy; and shortly after, the return of my soldiers confirmed the fact.

It appeared, that upon arriving within pistol-shot of the wall, Capt. Patten motioned to the men to lie down, while he crept forward to the breach; he had succeeded in ascertaining its state, and was about to return to the soldiers, when some inequality in the ground caused him to stumble a little, and the noise attracted the notice of the nearest sentinel, whose fire gave the alarm to the others,—one of those shots struck Capt. Patten in the back, a little below the shoulder, and he survived its effects but a few hours. Thus fell a fine young man, an ornament to that branch of the service to which he belonged, and a branch, which in point of men of highly cultivated scientific information, as well as the most chivalrous bravery, may challenge the world to show its superior.

The fire against the castle was continued on the following day, the

6th, with much effect, and the batteries in front of San Christoval had not only overcome the fire of that outwork, but towards mid-day the breach was judged assailable. At nine o'clock at night, one hundred men of the 7th division, commanded by Major Macintosh, of the 85th regiment, advanced to the assault; the forlorn-hope, consisting of six volunteers, and led on by Ensign Joseph Dyas of the 51st regiment, who solicited this honour, headed the attack.

The troops advanced with much order, although opposed to a heavy fire. Arrived upon the *glacis* they speedily descended the ditch, and the forlorn-hope, accompanied by an officer of engineers, pressed on to the breach. They had scarcely arrived at its foot, when the officer of engineers was mortally wounded, and Ensign Dyas was in consequence the only person to direct the men at the breach; for the main body, including the commanding officer, attempted to mount what appeared to them to be the breach, but which was in reality nothing more than an embrasure which had been a good deal injured by the fire of our batteries. Some of the most foremost succeeded in planting ladders against its rugged face, but their efforts were baffled by the exertions of the French engineers, who, notwithstanding our fire of grape and musketry, contrived to clear away the rubbish from the base of the wall; and the ladders were in consequence not of a sufficient length to enable the men to make a lodgment. A quarter of an hour had now elapsed, during which time several fruitless attempts had been made to enter the fort; and Major Macintosh, with his few remaining men, succeeded with difficulty in reaching their own lines, which they had left but a short time before with feelings of a very different description. None of the party could give any account of Ensign Dyas—indeed, how could they? for the *storming* party had never seen the forlorn-hope, from the moment they descended the ditch! As is common in such cases, there were many who said they believed that he, individually, was the last living man in the ditch, and it was a generally received opinion that Dyas had fallen. Major Macintosh, in company with a few friends, was sitting in his tent talking over the failure of the attack, and regretting amongst others, the loss of this officer, when to his amazement he entered the tent, not only alive, but unhurt. This brave young man, after having lost the greater part of his men, and finding himself unsupported by the storming party, at length quitted the ditch, but not until he heard the enemy entering it by the sally-port.

Notwithstanding that we had occupation sufficient *within* our lines to employ men of ordinary minds, still our fellows—or, as they familiarly called themselves, “the boys,”—found leisure to stroll a little beyond the limits allowed to the soldiers for their recreation. Perhaps in the whole British army, or in the army of any other nation, there were not a set of “boys” who knew better than ours did, how to find out which way the *land lay*; to see what “*was going*,” or to take share of it, whether it was freely offered to them or attempted to be withheld; their name too, “The Rangers,” implied—or they took it in that sense, I believe—their right to make little excursions, which, perhaps, another corps would not think of; and as they never had a turn for desertion, they were not as closely watched as might be necessary with other men; and their officers were never uneasy about them, because they were aware *they knew how to take care of themselves*.

Under all those circumstances, it is not to be wondered at that the country about our camp became a spot of some interest to the "boys." Lord Wellington might, and no doubt did reconnoitre Badajoz well, but not one whit better than the aforesaid gentlemen did the neighbouring country.

Not far from the river's edge, and distant about half a league from our lines, stood a snug cottage, at the rear of which was a plantation of olives, and at one side, under the brow of a little hillock, might be seen ten or a dozen bee-hives. Our fellows having tasted some of the *bitters* of a siege, were resolved to have a trial of the *sweets*, and this congregation of hives, carried by a *coup-de-main*, appeared in their eyes a set-off against the slow process of an operation such as they were engaged in. An attack was immediately resolved on, and as immediately put into execution; one of a party of three, a *nate boy*, volunteered his services, not only to reconnoitre the cottage, but to take a hive off by way of sample, that is, if such was found to be practicable; the other two lay at hand, and were ready to act as circumstances might require. A fellow named Roger Gafney was the individual who distinguished himself on this occasion; he passed by the rear of the cottage, rendering the caution of the Spaniard of no avail by this flank movement; and taking up one of the hives, rammed it into a sack, which he had borrowed for the occasion from his captain's *bâtman*. Success had crowned his efforts thus far, and he was carrying off his prize, when upon turning round the clump of olive-trees, he encountered some officers in their undress, who were coursing. "Hallo! what have you in the sack?" said one of them. Roger, at a glance, saw the awkward situation in which he was placed, and that nothing but stratagem could save him. Not in the least abashed, he replied to the question with the same freedom it had been put; thinking, or seeming to think, that those by whom he was addressed, were, like himself, on the *look-out*. "What have I, is it?—a bee-hive!" "A bee-hive! where did you get it?" "You *mane* to say where did I *find* it; why then, *avick*, I found it where it wasn't lost, and if it's *honey* yees are after, don't be standing here talking to me, but make haste, or by my *soul* they'll not *lave* yees a taste, at all, at all." "Who? where?" were the rapid interrogatories put to Roger. "Why, over there *fore-nents** you," replied he, pointing to a grove of trees in the very *opposite* direction of the place where the hives stood. Away galloped the officers to detect the delinquents, and away scampered Roger, lightening himself of his load, which he was reluctantly obliged to leave behind him; and it is scarcely necessary to say, that on the return of the disappointed officers, they did not find Roger Gafney *waiting to receive them*. Upon his return to his companions, he was asked why he left the hive behind him, "Why then sure," said he, "I thought it better to lose the honey, and save *my bacon!*"

On the 7th, 8th, and 9th, the fire against San Christoval was continued with increased vigour, and on the latter day it was resolved that the attack of it should be a second time made that night. A superior number of troops to those which failed on the 6th, but still *inferior* to the garrison of the fort, were selected for the attack, and the command given to Major Mac Geechy, an English officer in the service of Portu-

* Opposite.

gal, who volunteered this duty,—Dyas again leading the forlorn-hope. As before, the troops advanced under the fire of every gun that could be brought to bear upon them, and with much spirit descended the ditch. A little disorder amongst the men who carried the ladders, caused some delay, but the detachment pressed on to the breach without waiting for the re-organization of the ladder-men. The soldiers posted on the *glacis*, by their determined fire, notwithstanding their exposed situation, forced the enemy to waver, and if ever there was a chance of success, it was at this moment. Dyas and his companions did as much as men could do, but in vain. Their efforts were heroic, though unavailing; the spot was strewed with the dead and dying—the breach was covered with Frenchmen, and the *glacis* and ditch covered with our dead and disabled soldiers. Major Mac Geechy fell, pierced with bullets, and almost all the party shared his fate. Ensign Dyas was struck by a pellet* in the forehead, and fell upon his face, but undismayed by this, he sprang up and rallied his few remaining followers, but in vain. This heroic intrepidity deserved a better fate, but his efforts were paralysed by the obstacles opposed to him, and Dyas was at length reluctantly obliged to abandon an enterprise, on the issue of which he had a second time chivalrously, though unsuccessfully staked his life. As before, he was the last to leave the ditch, and with much difficulty reached our lines: his mode of escape was as curious as it was novel. One of the ladders that could not be placed upright, still hung from the *glacis* on the pallisadoes; this he sprang up, and in an instant he was upon the *glacis*, where he flung himself upon his face. The Frenchmen upon the walls seeing him fall at the moment of their fire, shouted out, "*Il est tué, en voila le dernier!*"

Dyas, perfectly collected, saw that his only chance of escape was by remaining quiet for a short time, which he did, and then seizing a favourable moment when the garrison were thrown off their guard by the silence that prevailed, he jumped up, and reached our batteries in safety: he and *nineteen* privates were all that escaped out of *two hundred*, which was the original strength of the storming party and forlorn-hope.

The failure of these two attacks led to many remarks, not only in our own army, but also in that of the enemy. It was our first attempt in the Peninsula to storm a place, and its success or failure was, without doubt, a matter that in a great measure involved the character, not only of the soldiers engaged, but of the two armies generally,—it was in fact a national concern. Our fellows knew that if the thing was practicable, success was sure to follow; but the French thought differently, and notwithstanding the defeats they had sustained in the different affairs which preceded this unfortunate event, they considered themselves the same invincible heroes that had conquered on the fields of Marengo and Austerlitz; and this little affair set them quite at ease with themselves. This is a dangerous idea to let a Frenchman get hold of, for though naturally brave, they are, as a nation, or even individually, the most gasconading race on earth—the Yankees always excepted; I shall therefore enter a little into the causes of this reverse.

* A small bullet, larger than a swan drop: four of them were inclosed in a piece of wood, three inches long, and at the top was placed the musket-ball. Upon being discharged the wood burst, and this shrapnel in miniature did considerable execution.

The evening upon which the first assault was made, (the 6th of June,) the storming party consisted of but one hundred men, while the garrison of the fort amounted to one hundred and fifty! Dyas at the head of six chosen men, (and accompanied by an officer of engineers, whose name I forget, and who was mortally wounded while he was in conversation with Dyas,) led the advance. The situation of the fort; the bastions that had been disabled by our fire, as also the breach, were well known to both those officers; but the remainder of the party, including the Commanding-officer, (Major Macintosh,) it would appear were ignorant upon points of such vital importance. The consequence was fatal. The handful of men that formed the forlorn-hope, (led on by their brave young commander,) jumped into the ditch, and proceeded along the curtain to the breach, but unfortunately the remainder of the party allowed themselves to be occupied before a dismantled bastion, which they mistook for the real breach. The ladders were lowered into the ditch and raised against this part of the wall; and while the soldiers were endeavouring to place them upright, they were cut off almost to a man. Dyas finding himself unsupported, ran back from the breach, and having reached the spot where his companions had been so uselessly, yet fatally employed, found it occupied only by the dead and wounded.

Thus far it was evident that the attack had failed, but it was also proved that the failure was owing to the misconception which the troops had of the real breach, because that portion of the storming party that had the ladders stopped short at a place where they should not. Dyas, although little acquainted with engineering, or not even having had a trial of the ladders which were but twelve feet long, at once pronounced the breach impracticable. He was immediately ordered to the tent of Gen. Houston, who directed the operations on the right bank of the Guadiana, and there he was closely questioned in the presence of the chief engineer, (I believe it was Colonel Squires): in answer to a question put to him respecting the depth of the ditch, he said, that he conceived it to be twelve feet, and he, one of the most active men in the army, judged of its depth from the great shock he felt when he jumped down. He was not credited; and the Engineer smiling, said, "That certain allowances should be made for *young beginners*;" this was too much for Dyas, but the brave fellow modestly observed, that he considered the estimate he had made of the depth of the ditch to be tolerably correct—and from this moment he made up his mind to head the next attack.

When the breach was again deemed practicable on the 9th, three days after the first attack and failure, Ensign Dyas waited upon Gen. Houston, and requested his leave once more to lead the advance. The General said, "No, you have already done enough, and it would be unfair that you should again bear the brunt of this business." "Why, General," said Dyas, "there seem to be some *doubts* of the practicability of this business on the last night of our attack; and, although I myself don't think that the breach is *even now* practicable, I request you will allow me to lead the party." The General still refused, when Dyas thus addressed him, "Gen. Houston, I hope you will not refuse my request, because I am determined, if you order the fort to be stormed forty times, to lead the advance so long as I have life." The General, fully appreciating the earnestness of this brave and high-

mindful young man, at length acquiesced; and Major Mac Geechy having volunteered to command the storming party, he and Dyas made the necessary arrangements to reconnoitre the fort that evening.

They made a detour by the edge of the river, and succeeded in reaching unperceived to within a short distance of the fort. Under cover of some reeds, they carefully examined the breach, which, to Major Mac Geechy, appeared a practicable one, but Dyas, better informed from experience, combated all the arguments of his companion, and desired him to watch attentively the effect of the next *salvo* from our batteries; he did so, and appeared satisfied with the result, "Because the wall," he remarked to Dyas, "gave way very freely." "Yes," replied Dyas, "but did you observe how the stones *fell* instead of *rolling*; rely on it if there was any rubbish about the base or face of it, the stones would *roll* and not *fall*." The observation was not lost on Major Mac Geechy, but it having been decided that the attack was to be made that night, both the leader of the forlorn-hope and the commander of the storming party at once made up their minds for the trial.

At ten o'clock at night, 200 men moved forward to the assault, Dyas leading the advance. He made a circuit until he came exactly opposite to the breach instead of entering the ditch as before: a sheep-path, which he remembered in the evening while he and Major Mac Geechy made their observations, served to guide them to the part of the *glacis* in front of the breach. Arrived at this spot, the detachment descended the ditch, and found themselves at the foot of the breach; but here an unlooked-for event stopped their further progress, and would have been in itself sufficient to have caused the failure of the attack. The ladders were entrusted to a party composed of a foreign corps in our pay, called "*the Chasseurs Britanniques*:" these men, the moment they reached the *glacis*, glad to rid themselves of their load, flung the ladders into the ditch, instead of sliding them between the palisades; they fell across them, and so stuck fast, and being made of heavy green wood, it was next to impossible to *move*, much less place them upright against the breach, and almost all the storming party were massacred in the attempt.

Placed in a situation so frightful, it required a man of the most determined character to continue the attack. Every officer of the detachment had fallen, Major Mac Geechy one of the first; and at this moment, Dyas and about five-and-twenty men were all that remained of the 200. Undismayed by these circumstances, the soldiers persevered, and Dyas, although wounded and bleeding, succeeded in disentangling one ladder, and placing it against what was considered to be the breach, it was speedily mounted, but upon arriving at the top of the ladder, instead of the *breach*, it was found to be a *stone wall* that had been constructed in the night, and which completely cut off all communication between the ditch and the bastion, so that when the men reached the top of this wall, they were, in effect, as far from the breach as if they had been in their own batteries.

From this faithful detail it is evident that the soldiers did as much as possible to ensure success, and that the failure was owing to a combination of untoward circumstances over which the troops had no control. Nineteen men were all that escaped.

On the night of the 8th of June, (the one previous to the second assault,) Ensign Dyas being on duty in the trenches, an order arrived to send an officer and fifteen men to a hollow spot in front of our lines, between San Christoval and the *tête du pont*, close to the Roman bridge which communicated with the Elvas gate. I know not how it happened, but Dyas was selected for this arduous duty. The object of this movement was for the purpose of observing if any and what communication or reinforcement would be sent to the fort. The detachment was to be recalled before day.

The night was unusually still, and every sound was distinctly heard, but nothing could be ascertained except that one piece of ordnance (a howitzer, I believe,) had passed over to the fort. Day at last began to dawn, yet no order had been received for the withdrawal of the party so stationed; their situation was most critical—within point blank shot of the fort in their rear. Dyas ordered his men to lie flat on their faces, though he every moment expected his situation would be discovered, and a rush made at him; nevertheless, unintimidated by his perilous posture, he dispatched a trusty man to the trenches, with orders to make known to the officer commanding the information he had been enabled to collect, and to know *what* was to be the final duty of the party.

"Now, mind," said Dyas, "*if* we are to be recalled, do you raise your cap on your firelock above the battery No. 1; if we are to remain, you know *what your duty is*." "By J—, and *plase* your Honour, *I do*; and recall or no recall, I'll be back with you in five minutes dead or alive," replied the poor fellow, who, I need not add, (after his speech,) was an Hibernian. "Do as you are ordered, Sir," said Dyas, "we have not a moment to lose."

A few minutes (a long time under such circumstances) only elapsed before the signal agreed upon was made; and Dyas, addressing a few words to his men, told them their safety depended on their adhering strictly to his directions. He then started them *singly* to different parts of the lines, and singular as it may appear, although it was now clear daylight, not one man was hit. What a fine fellow at the head of a regiment would this Dyas be!

It may, perhaps, be asked by persons unacquainted with these details, what became of Ensign Dyas, and they no doubt will say what a lucky young man he was to gain promotion in so short a time; but such was not the case, although he was duly recommended by Lord Wellington. This was no doubt an oversight, as it afterwards appeared, but the consequences have been of material injury to Ensign, now Capt. Dyas. This officer, like most brave men, was too modest to press his claim, and after having served through the entire of the Peninsular war, and afterwards at the memorable battle of Waterloo, he, in the year 1820—*ten years after his gallant conduct*—was, by a *mere chance*, promoted to a company, in consequence of the representation of Colonel Gurwood (another, but more lucky, forlorn-hope man) to Sir Henry Torrens.

Colonel Gurwood was a perfect stranger (except by character) to Dyas, and was with his regiment, the 10th Hussars, at Hampton Court, where Sir Henry Torrens inspected the 51st Regiment. Colo-

nel Ponsonby and Lord Wiltshire, (*not one of whom Dyas had ever seen,*) also interested themselves in his behalf; and immediately on Sir Henry Torrens arriving in London, he overhauled the documents connected with the affair of San Christoval, and finding all that had been reported to him to be perfectly correct, he drew the attention of His Royal Highness the Duke of York to the claims of Lieut. Dyas.

His Royal Highness, with that consideration for which he was remarkable, immediately caused Lieut. Dyas to be Gazetted to a company in the 1st Ceylon regiment.

Capt. Dyas lost no time in waiting upon Sir Henry Torrens and His Royal Highness the Duke of York. The Duke received him with his accustomed affability, and after regretting that his promotion had been so long overlooked, asked him what leave of absence he would require before he joined his regiment. Capt. Dyas said, "Six months, if His Royal Highness did not think it too long." "Perhaps," replied the Duke, "you would prefer *two years.*" Capt. Dyas was overpowered by this considerate condescension on the part of the Duke, and after having thanked him, took a respectful leave; but the number of campaigns he had served in, had materially injured his health, and he was obliged to retire on the half-pay of his company.

(To be continued.)

SINGULAR ORDER OF GEN. PRESCOTT IN 1794.

MR. EDITOR,—The following unique order, which I met with lately among the papers of a deceased friend, I believe to be genuine. It is an amusing specimen of the want of harmony that used in the "olden time" to exist between the Services—often, it is to be feared, to the prejudice of the public good. The Services now pull heartily together, and we may both enjoy a laugh at the whimsical rebuke the gallant Admiral met with for his interference in matters "*out of his own element.*"

Yours,

AMERICUS.

"LIEUT.-GEN. PRESCOTT'S ORDERS.

"St. Pierres, 16th June 1794.

"Whereas, Vice-Admiral Sir John Jervis has given orders, I am told, frequently, here on shore, and particularly, by a note dated off Point Petre, June 11th, 1794, which must have arisen from great ignorance, or great presumption and arrogance.

"If from ignorance, poor man! he is to be pitied; but if from presumption and arrogance, he is to be checked.

"It is therefore Lieut.-Gen. Prescott's orders, that in future no attention whatever is to be given to such Notes, or Orders, and his signature to such, to be as little regarded, as that of John Oakes, or Peter Styles."

THE SERVICES OF THE LATE ADMIRAL
THE RIGHT HON. THE EARL OF NORTHESK, G.C.B. AND
REAR-ADMIRAL OF GREAT BRITAIN.

THE Earl of Northesk was descended from an ancient family which had been settled for several centuries in the county of Angus, North Britain. In the reign of Charles I. the first creation of John Carnegie took place by the title of Lord Inglismaldie, Lord Lour, and Earl of Ettrie, which two latter titles he afterwards exchanged for those of Earl of Northesk, and Lord Rosehill. As was to be expected, the family were greatly attached to the unfortunate Sovereign by whom the honour had been conferred, and in consequence, the hatred of the Protector became particularly directed against them. For their loyalty to Charles, Oliver Cromwell caused them to be fined 10,000*l*. They were afterwards staunch supporters of the Revolution, and conspicuous for their steady and unceasing loyalty to the House of Hanover. The family mansion was taken possession of by the Pretender in the rebellion of 1715, when the Countess of Northesk was forced to fly, and sought refuge in Edinburgh Castle, where her ladyship was delivered of a son, who was christened George, after his Majesty George I. who condescended to be one of the sponsors, and was represented by proxy. This son became the Earl of Northesk, and entered as midshipman in the Royal Navy, passed through the several gradations of rank, and was Admiral of the Blue in 1773; became Admiral of the White, and died January 21st, 1792, aged 77 years.

The gallant nobleman, whose services we are now recording, was the third son of the above-mentioned Admiral, by Lady Ann Leslie, eldest daughter of the fifth Earl of Leven and Melville; and was born in 1758. At the age of eleven, Mr. William Carnegie embarked in the Albion with Capt. the Hon. Samuel Barrington; and afterwards served in the Southampton frigate with Capt. Mackbride, at the time he conveyed the Queen of Denmark to Zell; and in the Squirrel with Capt. Stair Douglas. Having undergone the necessary examination, Mr. Carnegie obtained an acting appointment as lieutenant of the Nonsuch, and in 1777 was confirmed into the Apollo, by Lord Howe. He afterwards served under Sir John Lockhart Ross in the Royal George, at the capture of the Caracca Fleet off Cape Finisterre, of the Spanish squadron under Don Juan de Langara, and at the relief of Gibraltar; then in the West Indies with Lord Rodney, who promoted him from the Flag-ship after the action of the 17th April 1780, to be Commander of the Blast Fire-ship. He was subsequently removed into the St. Eustatia; and was present at the reduction of the island of that name, 3rd of February 1781.

On the 7th of April 1782, Captain Carnegie obtained his post rank, and came home in the Enterprize, which in consequence of the peace was paid off. In 1783 his eldest brother died, when he succeeded to the title of Lord Rosehill, and on the equipment of the fleet, in consequence of the dispute with Spain, relative to Nootka Sound, was appointed to command the Heroine frigate, but was soon after paid off.

On the death of his lordship's father, on the 29th of January 1792, he succeeded to the title of Earl of Northesk; and in January of the following year, proceeded to the West Indies in command of the

Beaulieu frigate, and returned from thence in the *Andromeda* in December, and was soon after placed upon half-pay.

Lord Northesk remained unemployed until 1796, when he was appointed to the *Monmouth*, 64, and joined the North Sea fleet under the command of Admiral Viscount Duncan.

In May 1797, the mutiny, which had commenced in the Channel fleet, extended to the ships employed in the North Sea, and the *Monmouth* was brought by her refractory crew to the *Nore*. Perhaps, at no period was an event more to be deplored than this insubordination of the seamen. The nation being involved in a war in which her naval force could only be employed, and that force in rebellion against those who had its direction, caused universal gloom through all classes of society. At length some symptoms of return to their duty began to appear, and the mutineers sent for Lord Northesk on board the *Sandwich*, (the ship where Parker, the ringleader, and his misguided associates daily assembled,) to endeavour to effect a reconciliation with Government. On the 6th of June, the two delegates of the *Monmouth* went on board that ship from the *Sandwich*, with a request that his lordship, who was confined to his cabin, would accompany them. On reaching the *Sandwich*, Lord Northesk was ushered into the cabin, where Richard Parker, as President, and about sixty seamen, acting as delegates, from the several ships, were sitting in close deliberation. Lord Northesk was accompanied by a gentleman, and before the commencement of business, Parker demanded to know who he was: upon being told he was "an officer of the *Monmouth*, who accompanied his lordship as secretary," he said, "Who knows him?—say, delegates of the *Monmouth*, what kind of man is he?" The delegates replied, he was "a worthy good man," and it was instantly voted that he might attend the conference. The president of these infatuated men then said to his Lordship—"That the committee, with one voice, had come to a declaration of the terms on which alone, without the smallest alteration, they would give up the ships; and they had sent for his Lordship as one who was known to be the "seaman's friend," to be charged with them to the King, and he must pledge his honour to return on board with a clear and positive answer within fifty-four hours." Parker then read the letter to his Majesty. Lord Northesk informed the delegates, that "he certainly would bear the letter as desired; but could not, from the unreasonableness of their demands, flatter them with any expectation of success." They persisted, that "the whole must be complied with, or they would immediately put the fleet to sea."

The following paper was then handed by Parker to his Lordship, and is a curious document of the methodical manner in which the rebels conducted their mischievous designs.

" TO CAPT. LORD NORTHESK.

" Sandwich, June 6th, 3 P.M.

" You are hereby authorised and ordered to wait upon the King, wherever he may be, with the resolutions of the Committee of Delegates, and are directed to return back with an answer within fifty-four hours from the date hereof.

(Signed) " R. PARKER, President."

Upon receiving these instructions his Lordship left the *Sandwich*, three cheers being given by the mutineers, and he was put on board the *Duke of York*, Margate packet, for London.

Lord Northesk lost no time in reaching the Admiralty, and soon after, attended by Earl Spencer, then First Lord, waited upon His Majesty. The insolent demands contained in the communication were instantly rejected; and Capt. Knight, (the late Admiral Sir John,*) who had obtained leave from Parker to come on shore from the Montagu, whose surgeon had been tarred and feathered and then rowed on shore, carried to the misguided and deluded men the refusal of the Board of Admiralty.

The submission of the fleet began on the 9th of June, in consequence of the extensive preparations which were ready to commence against the ships, and the Repulse and Leopard made their escape, the former up the river Thames; the latter unfortunately got aground, and was fired on by the Monmouth and Director, when Lieut. Delanoe lost his leg, and one seaman was wounded.

The seamen having returned to their duty, and Parker having been executed, Lord Northesk resigned the command of the Monmouth, and remained unemployed until 1800, when his Lordship was appointed to the Prince, 98 guns, in the Channel Fleet, under the command of his illustrious relative the Earl of St. Vincent, in which ship he continued till the peace in 1802, when he again returned from active service.

On the renewal of hostilities with the French Republic in 1803, his Lordship was amongst the foremost to offer his services, and was immediately appointed to the Britannia of 100 guns. In her he served in the Channel under the command of the Hon. Admiral Cornwallis till May 1804, when he was promoted to the rank of Rear-Admiral of the White. In the following month, he hoisted his flag in the same ship, and continued to serve in her on her former station in the arduous blockade of Brest during the trying and tempestuous winter of 1804; and till August in the following year, when he was detached with the squadron under the orders of Sir Robert Calder, to reinforce Vice-Admiral Collingwood, off Cadiz.

In the glorious and decisive battle of Trafalgar, on the ever memorable 21st of October, the Britannia bore his Lordship's flag; and took a distinguished share in achieving the victory. On that memorable day the Britannia, Capt. Charles Bullen, broke through the enemy's line, astern of the fourteenth ship, in the most gallant and masterly style; and soon after completely dismasted a French 80-gun ship, on board of which a white handkerchief was soon displayed in token of submission. The Britannia afterwards singly engaged and kept at bay three of the enemy's van ships. In this conflict the Britannia had 10 killed and 42 wounded.

During the continuance of this long and sanguinary engagement, Lord Northesk zealously emulated the example of his heroic Commander-in-Chief; and when the order was given for destroying such prizes as could not be secured from the heavy gale that followed the action, his Lordship would on no account allow L'Intrepide, the nearest to the Britannia, to be scuttled until his boats had rescued all the wounded men and the whole of the surviving crew.

Lord Northesk, for his brilliant services on this occasion, was created a Knight of the Bath on the 29th January 1806; receiving the thanks

* Admiral Sir John Knight, K.C.B. died on the 16th of June; his services will be recorded in the obituary of the present month.

of both Houses of Parliament; the freedom of the City of London, and of the Goldsmiths' Company, with a sword of the value of one hundred guineas from the City of London, an Admiral's medal from His Majesty to be worn round the neck, and a vase of the value of three hundred pounds from the Patriotic Fund at Lloyd's.

Lord Northesk, in consequence of ill health, resigned his command, and returned to England in the *Dreadnought*, accompanied by the *Britannia*, and three of the prizes, and reached Portsmouth 16th May 1806.

A promotion taking place 28th April 1808, Lord Northesk became a Vice-Admiral; and on the 4th June 1814, an Admiral.

In 1815 the Order of the Bath was remodelled and divided into three classes, when the Earl of Northesk was placed in the first, and became G.C.B.

In consequence of the death of Admiral Sir William Young, Admiral Sir James Saumarez was appointed Vice-Admiral of Great Britain; and at the same time, 21st Nov. 1821, the Earl of Northesk was appointed Rear-Admiral of Great Britain in the room of Sir James Saumarez.

In May 1827, Lord Northesk was appointed Commander-in-Chief at Plymouth, where his Lordship remained until 1830, when the period allowed for the command expired, and which was the last he held.

Lord Northesk had been for some years afflicted with asthma, but no serious apprehensions of his sudden dissolution were entertained. This event; by which the Navy has lost a bright ornament, the nation one of its brave defenders, and the family one of the best of parents,—took place on the 28th of May, at his Lordship's residence in Albemarle-street, after an illness of three days, which was considered so slight by his Lordship, that he had intended to have been present at the drawing-room of Her Majesty, to celebrate His Majesty's birthday on the morning of which he became a corpse.

The funeral of this brave and distinguished nobleman took place in St. Paul's Cathedral, 8th of June, in which sacred edifice repose the ashes of Nelson and Collingwood, who shared with Lord Northesk the laurels won at Trafalgar. The funeral was strictly private, and attended by the relatives and friends of his Lordship. In room of the pall which usually covers the coffin on similar occasions, was substituted the English flag supported, as pall-bearers, by Vice-Admiral Sir Richard King, Bart. K.C.B., Vice-Admiral Sir William Hotham, K.C.B., Rear-Admiral Walker, C.B., Rear-Admiral Rodd, C.B., Rear-Admiral Sir Thomas Masterman Hardy, Bart. K.C.B., and Rear-Admiral William Parker, C.B.

The late Earl of Northesk married 1789, Mary, daughter of William H. Ricketts, Esq. by Mary, sister of the late Earl, and mother of the present Viscount St. Vincent, by whom he had issue George Lord Rosehill, who was lost on board the *Blenheim*, where he was Midshipman, in 1807, when that ship foundered in the East Indies, having on board the flag of Rear-Admiral Sir Thomas Troubridge; and William Hopetoun, now the Earl of Northesk, and several other children, one of whom is Midshipman on board the *St. Vincent*, with Vice-Admiral Sir Henry Hotham, in the Mediterranean.

The late Earl of Northesk sat in several Parliaments as one of the Sixteen Representative Peers of Scotland, in which part of the United Kingdom is situated one of the family residences, *Ethie House*, Forfarshire; the other residence is *Rosehill House*, near Winchester.

REMARKS ON THE COMPARATIVE SERVICES AND REWARDS
OF THE SEVERAL BRANCHES OF THE ARMY.

If the maxim be a sound and a just one, (which I believe few will be found bold enough to deny) "that he who toils the hardest, and performs the most arduous work, should receive the highest wages," it may very reasonably be inquired, why the same principle should not apply equally to the military profession as elsewhere. I have served long enough in the field to know, that an army cannot be complete without a due portion of cavalry, infantry, artillery, engineers, sappers, and miners, ponton train, &c. and am fully aware therefore of the merits and utility of each respective branch; and I well know also that in most cases, they are so far dependant on each other, as to be literally helpless when separate. The infantry may, indeed, be in some measure excepted; for it is the only arm that can move, act, and fight on emergency ALONE, in every description of country, unaided and unsupported by the other branches. I am always happy to hear that any accession of good fortune has fallen to the lot of my fellow-soldiers, be they of the ordnance, infantry, or cavalry; and having said thus much, I trust I shall be acquitted of entertaining any thing like feelings of jealousy, if I confess that I have been puzzled and put to my wits' end to know, in the first place, *why* and *with what show of justice*, the pay of the *infantry* should be inferior to that of the cavalry, engineers, and artillery; and secondly, why both cavalry and infantry should not enjoy the same boon which has been granted to the two ordnance corps? I allude to the rank of *Major* having been discontinued. In short, when a captain either of cavalry or infantry is promoted, *why* he should not jump over the rank of *Major*, and become a Lieutenant-Colonel, as is the case in the engineers and artillery? It is almost needless to observe, that many a good and experienced old soldier *holds on* by the rank of *Major*, (in the infantry particularly) perhaps eight, ten, or a dozen years, from not having *funds* to purchase a Lieutenant Colonelcy, or not possessing interest sufficiently strong to push him forward to that rank. In the interim, many Captains of the two ordnance corps are promoted; and in ONE DAY they spring from the rank of Captain to that of Lieutenant Colonel, thereby *distancing* the Majors of cavalry and infantry by many years. I would ask, is this fair play? Now, as the infantry labour under the *first* and *second* of these disadvantages, and the cavalry under the *second*, I propose giving a sketch (and it shall be an impartial one) of the comparative services and employment of each branch in the colonies and in the field, whereby the candid and unprejudiced will be able to judge on whom most of the hard blows generally fall, and by whom the drudgery of the service is chiefly performed.

First then as to service in the colonies. It is not the fashion to send the artillery or engineers to our East India possessions; but, with that exception, they are liable, I presume, to serve in any part of the globe. West India service, happily for the cavalry, does not fall to *their* lot, nor indeed, except when an army takes the field in Europe, or a small force of dismounted dragoons accompanies an expedition to a distant

part of the world, (Egypt, or Buenos Ayres for instance,) are our cavalry regiments ever stationed out of the United Kingdom. Four regiments of light dragoons do duty in the East Indies; but, as I have already said, our cavalry know the West Indies, (that grave of myriads,) *only by name*, or by a glance of the eye at a map of those pestilential islands. The British infantry is dispersed over every part of the globe, being exempt from no one station whatever, good, bad, or indifferent; and it has so few reliefs at home, that a regiment which has been grilled and roasted upwards of twenty years in Madras, Bombay, or Bengal, must, as a matter of course, at the expiration of three or four years spent in Ireland, between recruiting and *still* hunting, prepare to cross the Atlantic, and either freeze for a dozen years in the inhospitable regions of Canada, or broil the remnant of their lives in some rascally, obscure, sugar island.

As far then as regards our colonies, it appears that the cavalry do not serve in the West Indies, nor the engineers and artillery in the East, and that the infantry are dispatched, *per* villainously bad and leaky transports, to every hole, creek and corner, where John Bull has possessions.

Let us now take the *field*, and see how the different arms are there employed. Perhaps the campaigns of 1808, 1809, 1810, 1811, 1812, 1813, and 1814 in the Peninsula and the South of France, and that of 1815 in the Netherlands, will be admitted as a tolerably fair criterion by which to judge of the duties that each separate branch of an army in the field is likely to be called on to perform.

Sieges shall first be considered. Here the engineer department comes particularly into play, and it has no sinecure either. From the very commencement of operations against a fortress until it is about to be stormed by the breaches or escaladed, the engineer has ample employment; he is much exposed to the enemy's fire, and has his full share of the constant fatigues and dangers inseparable from all sieges; and, to this may be added, a great responsibility and anxiety.

Until the *trenches* are tolerably well completed, and the period has arrived for constructing the batteries, and bringing up the battering train, the artillery (having no positive business in the trenches, that I am aware of,) is unmolested by the unceasing discharge of shot and shells from the besieged; of which the covering and working parties of infantry, and the engineers, have the exclusive benefit. But, from the moment the process of constructing batteries commences, and of bringing the heavy guns into the trenches, the artillery is especially pounded with shot and shells; inasmuch as the *besieged* rarely fail to concentrate as heavy a fire as they possibly can, on the *besiegers' batteries*. The walls once breached, and every thing ready for the assault, the labours of the artillery and engineers may be considered as nearly concluded; for it is unnecessary to observe that the work of penetrating the deadly breach is not allotted to them; except indeed that an officer of engineers sometimes accompanies the storming party to point out the breaches.

Next then, as to the duties and employment of cavalry in sieges. As they neither dig the trenches, assist to construct batteries, nor are employed in storming, they do not share in the labours, fatigues, and dangers attendant on such operations. A few squadrons, perhaps, re-

main encamped, out of reach of the fire from the walls, ready to succour the covering and working parties, in the event of their being pressed back by *sorties*, wherein the enemy's cavalry sometimes accompany their infantry. They post a few videttes, and patrol occasionally in different directions; but their proper and more usual post is with that part of the army which covers the besieging force; and, unless that covering army is attacked, the broken heads amongst the cavalry will necessarily be but few:—in such sieges at least as those in which I had the honour to serve, viz. Ciudad Rodrigo and Badajoz.

I may observe also that neither at Burgos nor San Sebastian did our cavalry sustain any loss worth mentioning. It is true, that in covering the retreat of the army from Burgos to Salamanca, the cavalry had no idle time of it; yet, that must not be confounded with the operations of the siege of Burgos. Infantry may be termed the *sheet anchor* in sieges. They break ground under the fire of the place, they dig the trenches, assist at constructing the batteries, and in carrying ammunition into them when completed, and they lend a hand at placing the heavy guns in battery.

On them devolves not only the various duties of working parties, but they furnish also numerous advanced parties in front of the trenches; ay, even to the foot of the walls, where, exposed hour after hour to an unremitting fire of musketry, grape, shells, &c. they are the first to grapple with *sorties*, which may constantly be reckoned on both by day and night. Lastly, when the walls are breached, to the infantry alone is confided the honourable but bloody duty of taking *the bull by the horns*, and of forcing an entrance into the works, through a murderous fire of musketry, grape, and hand-grenades.

During the campaigns of 1808, 1809, and 1810, in the Peninsula, the British army carried on no sieges; our first essay of the kind being against Badajoz in 1811. I state this, solely with the view of showing (as I set out by declaring I would endeavour to do with strict impartiality,) the *degree of hard work* which may be generally considered as likely to fall to the lot of each separate branch, taking one campaign with another. Impartial persons must admit, that, as previously to the *fourth campaign* in the Peninsula no siege was undertaken by us, the engineers were not, as a matter of course, called much into action. Their zeal and activity, and the ability displayed by them in directing the construction of those works in the lines of Torres Vedras, which our consummate chief first projected, are too well known to need any eulogy from so humble a pen as mine. Their perseverance, gallantry, and unremitting zeal, in all the sieges in Spain, have, moreover, been the theme of admiration.

Having compared notes between the duties and services of all parties, both in the colonies and at sieges, let us next see how they each fare when an army either advances or retreats, when the many harassing duties of the outposts are to be performed; and, finally, when the business is wound up with a general engagement. I commence with the cavalry.

Whenever the features of the country will admit of their acting, the most advanced posts are entrusted to them. They form the advance guards in forward movements, and rear guards in retrograde ones; and when at length the army is drawn out to give or accept battle, the

cavalry are usually held in reserve, to charge lines, columns, or squares of infantry, or bodies of cavalry, as opportunities for their acting may offer. It must be apparent enough to every man who has served in the field, that the cavalry, especially the hussars and light dragoons, are always on the *qui vive*, and that they are much harassed in guarding from surprise thousands of their comrades who repose in camp or bivouac, relying on the activity and alertness of those in their front. The duties of light infantry are much on a par with those of the light cavalry, the former being at hand, (although it often happens otherwise,) to support the latter, and generally intermixed with them in outpost duties of all kinds, advance and rear-guards, &c. &c. &c.

It would consequently be absurd to deny, that on the light cavalry and light infantry devolve the most arduous, active, and trying parts of campaigning, when two armies are put in motion, when they commence manœuvring, and when they approach each other with a view of giving battle. The particular nature of the duties allotted to the light troops, bringing on an infinity of skirmishes *that count for nothing in the Gazette*, but in which many a good fellow gets a broken head, and is never mentioned or thought of after, because *affairs of posts*, (as they are styled by those rearward,) do not come under the head of *general actions*. Let it not be forgotten that in general engagements also the light troops take a very prominent part; and those who fancy, (as I have known some theorists declare,) that as soon as an army has concentrated, taken up its position, and offered battle to its antagonist, the business of the light troops has principally ceased, betray a woeful ignorance of the actual state of affairs in such cases.

Infantry of the line on many occasions during a campaign, are obliged to take a proportion of outpost duty, and they must unavoidably do so when an army occupies an extended line of position, and when each division is pushed forward near its enemy, as was the case with most of ours in the Pyrenees in 1813. The same observation is applicable to heavy cavalry, which is very commonly necessitated also to take a share of outpost duty.

That by far the greater portion of *hammering, milling, and downright hard fighting*, has fallen on the shoulders of the *infantry* in every action fought by the British army for the last thirty years, the following battles will fully attest:—Alexandria, Maida, Roliça, Vimiera, Corunna, the passage of the Douro, Talavera, Gen. Crawford's action on the Coa in 1810, Busacco, the various actions during Massena's retreat out of Portugal, terminating with that at Sabugal, Barossa, Fuentes d'Onore, Albuera, the surprise of Gen. Gerard's division by Lord Hill, Salamanca, Vittoria, the various battles in the Pyrenees, the passage of the Bidassoa, and the storming of the entrenched position in the pass of Vera in October 1813, Nivelle, Nive, Orthes, Tarbes, Toulouse, Quatre Bras, and Waterloo.

I must not omit to mention the thousands of infantry that perished at the sieges of Rodrigo, of Badajoz, at the fortified convent in Salamanca, a short time previous to that memorable battle, at the assault of the forts of Almaraz, at the defence of Tarifa, at Burgos, at San Sebastian, and at the blockade *of* and sortie *from* Bayonne. If those are not conclusive, I have no farther proofs to adduce in support of my creed.

Let me not be misunderstood as wishing to insinuate that the cavalry, artillery, and engineers, did not take an extremely active part in many of those operations; but the best proof, perhaps, to those who may be disposed to doubt the accuracy of my statement, will be a reference to the returns of killed and wounded in all the above-mentioned engagements, and the numerical strength of each arm in the field at the time. The hardships, privations, and dangers of campaigning, must not be considered as consisting only in fighting one, two, or more battles in a year, but in the unceasing nightly watching, and the consequent want of rest, which falls so particularly on the cavalry and infantry; I repeat that those harassing duties devolve exclusively on them, because neither artillery nor engineer, strictly speaking, ever take any share of the *very advanced posts*. Indeed, from the nature of their service they cannot possibly be supposed to do so. At the conclusion of a march, the guns are parked, the horses picketed, and the gunners encamped for the night; the whole well guarded by posts of cavalry and infantry far advanced in their front.

I served many years with a part of the army to which a troop of horse artillery was attached, and had, therefore, innumerable opportunities of knowing, that even horse artillery belonging to an advanced corps, have *comparatively* an easy time of it. Sometimes a couple of guns are sent forward with a squadron or two of cavalry, or with some companies of infantry, when it is intended that the picquets should make a stand at a bridge, ford, or defile; but even in such cases, the guns are necessarily covered and protected by parties of cavalry or infantry in front, and the artillery man can, therefore, repose for the night, whilst the light troops keep a sharp look-out for their safety. If this is the case with *light artillery*, how much more so must it be with brigades of heavy guns in the rear!

Let me ask my old horse artillery friends with whom I served in the last war, if any of them are still in the land of the living, whether (independent of being exempt from the multiplicity of pickets and other outpost duties, and from the eternal skirmishing which, either in advancing or in retreat, occupied the time and attention of the cavalry and infantry from year's end to year's end,) they had not at all times and in every situation in which it was possible for the army to be placed, the advantage of transporting with them, *inside or outside* the carriages belonging to the guns, certain little comforts and conveniences for man and horse which the cavalry and infantry very frequently indeed wanted for days together, when the proximity of the hostile armies rendered it necessary to send away the baggage to the rear, whereby the officers, of infantry in particular, having nothing with them, except what they stood upright in, were, not unfrequently, prevented from having access to razor, comb, clean linen, &c. &c. for a week at a time; nor did they know the taste, during that period, of any thing but a short allowance of mouldy ship biscuit, or half rations of tough lean beef, grilled on the lid of a soldier's tin kettle?

I am not ignorant of the fact, that it is *contrary to the strict letter of the law to affix one iota of private baggage to the gun-carriages*; yet I am inclined to believe that many crimes and offences of a far more heinous nature go every day unpunished than that of transporting with the field-pieces a small portmanteau, a *bell-tent*, a few feeds of

corn for a horse, a loaf or two of bread, wine, spirits, cigars, a bullock's heart or the kidneys of the said animal, and other odds and ends, such as were occasionally to be picked up in a bivouac.

To the unsophisticated and inexperienced soldier, these may appear "trifles light as air;" but he may take my word for it, that in cold, dreary, wet, comfortless bivouacs, during a succession of severe campaigns, such "*trifles*" are of incredible value, and are the very best preventives against agues, fevers, and other devilmments of the kind. I believe the British artillery to be unrivalled; and, if I add, that no man holds it in higher admiration and respect than myself, I state my real, genuine and unfeigned sentiments. I have served with it in the Colonies, in the field, and at sieges, and I ought therefore to be able to appreciate its excellence.

Some apology is due, perhaps, to the members of that distinguished corps, in common with those of the engineers, cavalry and infantry, for the unceremonious manner in which I have discussed the particular nature of their respective services. As long as the present system of European warfare continues in fashion, I feel thoroughly convinced that the *drudgery* of all armies during campaigns, must inevitably fall on the cavalry and infantry; and more especially on the *latter*, inasmuch as they take a prominent part in sieges as well as in all other field operations. That the British infantry also has no sinecure in colonial duties, I think I have proved beyond a doubt. Like the artillery, the engineer department is exempt from pickets, guards, foraging parties, skirmishes, advance and rear-guards, and a hundred other trying and wearisome duties which fall on the cavalry and infantry. True it is, that in *sieges* the engineer has enough to do. If a pontoon bridge is to be established, if field-works are to be thrown up to strengthen a position, if bridges are to be broken down to secure the retreat of an army, or if they are to be repaired in pursuit of a beaten enemy, the engineer takes an active part. Let it nevertheless not be forgotten that *all* and *every part* of such duties *are actually carried into effect by the infantry*, under the fire of the enemy or not, as it may happen.

The officers of engineers are distributed to the different divisions of an army, and some of them remain at head-quarters. Whether attached to one or the other, even the engineer subaltern rides a good horse, he frequently partakes of the good cheer at the table of his division general, and, in nineteen cases out of twenty, he turns into some sort of habitation with a roof on it, and enjoys a good night's repose, at a time when the cavalry and infantry are employed far in front carefully watching an experienced and enterprising enemy.

Finally, in most cases, (sieges always excepted,) the engineer accompanies the staff of the army, on which department, the whole military world well knows, the loaves and fishes have always been poured forth in the greatest possible abundance.

I have endeavoured to compare with impartiality the general calling (if I may use the term) of all branches, from the first moment a youth leaves his mother's apron-strings, and becomes a soldier of cavalry, infantry, or of the two ordnance corps. I have ever been of opinion, that the infantry, which is the *main stay*, the *bulwark* of armies, should

at least enjoy the same advantages as their brother soldiers of the cavalry, artillery, and engineers; nor can I conceive that any unprejudiced person will think my notions on the subject outrageous, unreasonable, or unjust.

It has been argued, that the price of commissions in the cavalry is higher than that of the infantry; and that, therefore, the pay ought to be better. Be it so; but the knife will cut both ways. The officers of the two Ordnance corps obtain their commissions without paying a fraction for them; yet, their pay is likewise higher than the infantry. Perhaps we shall be told that being *scientific corps* is a sufficient reason for it. I should, nevertheless, be glad to know, whether the expense of educating cadets at Woolwich is defrayed from their own pockets? If not, the argument is futile.

Frederick the Great of Prussia, if certain authors have not belied him, not only paid his infantry quite as high as any other branch, but they, moreover, took precedence of all other arms. Now, I will confess, that old Frederick's opinion on such matters weighs quite as forcibly with me as that of any human being who ever commanded an army. I will now conclude, Mr. Editor, by assuring you and your readers, lest I should be accused of being actuated by self-interested motives, that whether the British infantry remains until doomsday on the same footing as at present, it cannot affect me directly or indirectly. I have passed the rank of major many, many long years; and, whether the pay of the infantry be increased or whether it remain in *statu quo*, my income will neither be diminished nor increased.

AN OLD SOLDIER.

UNITED SERVICE RECREATIONS AT PORTSMOUTH.

THE Naval and Military Officers stationed at Portsmouth, have commenced their cricket meetings with great spirit. We find that the ladies residing in that neighbourhood have subscribed for a bat to be presented to the Member of the Garrison Cricket Club who can make the greatest number of runs during the next three months; and many are the speculations as to who will be the successful candidate. The following epigram from the pen of Miss L. H. Sheridan, was made on the occasion.

BAT, OR BALL.

I'm told the Portsmouth "ladies fair" intend
 Their aid towards the cricket-club to lend:
 Who at this sport most notches can achieve,
 A *Bat* from these fair ladies shall receive.

As 'tis a game for gentlemen to play,
 A *Bat* may suit their fancies, I dare say;
 But were we ladies players, one and all,
 I can assure you, we'd prefer a *Ball*!

THOUGHTS ON THE SYSTEMATIC PRACTICE OF
NAVAL MANŒUVRES.

A warm feeling of interest for the welfare of the Navy, has led the writer to view with satisfaction the introduction of many changes tending to that end, but a long absence from active service, and a residence at a distance from the naval arsenals, has deprived him of that minute acquaintance with its actual state, with respect to some particulars, that is enjoyed by those who are placed in opposite circumstances: hence it would afford him gratification to learn that the assumption on which the following remarks are founded is erroneous.

It has occurred to him, that of the various branches of naval science that are likely to be neglected during a long peace, one of the most important is that which teaches the art of conducting and manœuvring fleets; and his fear that it does not at present receive proper notice, arises chiefly from recollecting, that it was not practised to the extent that in his humble opinion it ought to have been in the two fleets he served in during the last war, and they were principal ones. This averment affords fair grounds for the inference, that it is not now cultivated so much as the actual circumstances of the service will permit; thus forming an exception to the praiseworthy ardour with which most other kinds of nautical knowledge are pursued. Although it was mostly his good fortune to serve under captains who were not regardless of the instruction of the midshipmen, he does not remember a solitary instance of the attention of the latter having been particularly directed, either to the theory of manœuvring as contained in the now exploded Signal Book, (the only official authority of that period;) or to its practice, which never extended beyond the ordinary evolutions, that were required to preserve the bearing of Cape Sicie, north-west. Nevertheless, a practical knowledge of this art can be acquired only by service in fleets, and even there the chance of the young and too often thoughtless midshipmen being led to its study, has been shown to be extremely doubtful. To past neglect, therefore, of remedial measures, is to be attributed the fact, that it is not uncommon to hear officers of respectable professional attainments freely acknowledge their ignorance of this department of their calling. With reference to the probability of disasters arising therefrom, it were of small account perhaps, if this ignorance was confined to the junior grades of the service: as one proof, however, among several that could be cited, that this is not the case, the writer has been informed by an officer who was present upon the occasion, that within a few years, the subject having been incidentally started at a commander-in-chief's table, a captain of many years standing declared his ignorance of it; without, however, seeming to esteem it lightly, as a cloak for what he might, under other circumstances, have felt ashamed of, but rather in a tone of regret that he had never served in a fleet: the blunt candour which induced such a confession may be taken as a gage of its sincerity. Had the death of the Admiral devolved the command of the station upon this officer, there is ample reason to suppose that the honour of the flag would have been in safe keeping, so far as the defence and seamanlike handling of his ship were concerned, (main points, it is readily admitted); but

if a sudden declaration of war had sent an enemy's force to oppose him, commanded by a *Suffrein*, the writer cannot but imitate the candour he has lauded, by expressing his opinion that the above qualities, which would have shone with such lustre in relation to a single ship, might not *alone* have availed their possessor to lead a squadron or fleet to victory.

During the last war, frequent instances occurred of commanders being placed in the temporary command of ships of the line attached to fleets, and it is very probable that some of those officers had never before served in such ships. Pushing our surmises a reasonable degree farther, it might appear that some of them had never sailed in a fleet for a longer time than would suffice to exchange dispatches, and consequently, they could have no practical acquaintance with the duty of even a "*gib and stay-sail jack*.* Now the writer readily concedes, that frigates, sloops of war, &c. form the best school for the attainment of the essentials of seamanship, knowledge of foreign seas, and other useful matter; but he nevertheless considers the education of a naval officer incomplete whilst it lacks the branch of which he is treating. A collateral support of this opinion may be found in a memorial that was addressed to the Admiralty, by three highly distinguished Captains, (two of whom are Flag-officers,) who considered themselves aggrieved by the selection of a junior officer as Captain of the Fleet, upon the last Copenhagen expedition. Quoting from memory, one of the grounds of complaint was, that the officer in question had "*never commanded a ship in line of battle!*" Notwithstanding he was pre-eminent in the depth and variety of his nautical knowledge, yet his presumed inexperience in that branch upon which the above objection was founded, may have given rise to doubts of his competency to aid the Commander-in-chief in certain contingencies.† It would be useless to plead for the utility of the art, whether applied to purposes of attack or of defence, as this was most strikingly illustrated by Admiral Jervis, who, by a promptly-executed manœuvre, defeated a very superior force;—

* The converse of the above statement was injurious both to the service and to individuals. There are lieutenants, who from want of interest, or from the mistaken judgment of their friends, served their whole midshipman's time in three-deckers, that were chiefly stationed off Brest or Toulon, and never visited any other foreign ports than Gibraltar or Mahon. The *Queen*, 96, was actually out of port for twenty-two months, and for most of that time she was off Cadiz, probably a *unique* fact in maritime records. In such ships, some of the mids, from the force of habit, ceased to desire more active employment, and all of them must have remained practically ignorant of certain duties incident to their profession. A greater number served all this important period in two-deckers, which are certainly a preferable class of ships to the others. It may be questioned, however, if a longer term than three years can be served in a ship of any particular class, and produce corresponding advantages in the formation of professional character: unless the *élève* should have the good fortune to be placed with one of those ornaments of the profession, who combines the principles and manners of a gentleman, with the best qualities of an officer; let him abide in such tutelage as long as possible, for the happy union here described, although less rare than formerly, is not and never will be very common. In general, therefore, a change of both ships and captains, and between several classes of the former, appears most desirable. The peace custom of keeping ships in commission for the term of three years only, commonly effects this change; but a long war may lead to a recurrence of the evil deprecated, unless it should be officially prevented.

† See the Naval Chronicle of 1807 or 1808, for this memorial.

and by Admiral Cornwallis, who by an equally judicious disposition of his squadron of seven sail, foiled thirty sail of the enemy, and secured a place for his name in naval annals, which the gratitude of his country did little to emblazon: for no sea officer of this age, backed by such various, distinguished, and long services, ever received such a shallow meed of reward, and from a people too, whose liberality to their public servants is munificent. The assumed neglect which forms the subject of these observations, may be referred to the circumstance of the method of close quarters having been so successfully acted upon in the two last wars, and if they could always be resorted to at the will of either of the hostile parties, there would be little need of manœuvring; but as such meetings must principally depend upon a reciprocity of desire and of interest, which seldom exists, it becomes advisable to cultivate the means that will give the option of leading to such an end when wished for.

A cursory review of naval history seems to lead to a conclusion, that the modes of sea-fighting move in a kind of cycle: in the sea-fights of the 16th and 17th centuries, there was some very close work between ourselves and the Dutch: in some of the subsequent wars, distant cannonading had its day: still more recently, and in our own time, close quarters have been revived; and it is not difficult to imagine circumstances which may render the contrary practice the manifest policy of a fleet, and in such a case, to adopt it with effect, the commanders should be able to manœuvre skilfully. Suppose two fleets of considerable numerical inequality to meet, and that the inferior are greatly excelled in gunnery, this fleet would do well to engage its opponent distantly, for its success would thus be rendered more certain, and its loss in reaping it would be less than in the contrary case. On the other hand, it would be most advantageous to the other fleet to close, in order to make up for its deficient gunnery, as its chances of success would vary inversely with the distance at which it might engage: that is to say, at the nearest possible distance they would be greater than at any other. The former part of this theory has been practically controverted by Nelson and by others, nevertheless it seems accordant with reason, and among recent events derives support from the *tactics* practised by the enemy in the single actions of the American war. However, it may be observed, that there is not a strict analogy between the engagements of fleets, and those of single ships; because in the latter, the ship that is equal in force and sailing, and superior in gunnery to her adversary, will most likely subdue her: whereas, in the former case, it may be in the power of a very inferior fleet, possessing the latter advantage, in the contingencies of a shift of wind, or of a partial breeze, so to regulate its motions, as to attack a part of its disabled opponent's forces, with a decided advantage. An opinion unfavourable to manœuvring is partially entertained, arising from the decisive results that attended Nelson's battles; but in order to dispel this error, it is only necessary to consider the circumstances in which he found his adversaries,—these enabled him to dispense with the ample and matured resources connected with this subject, with which it is well known his mind was stored: in two instances the enemy were at anchor, and in the last and "crowning act" of his glorious career, confiding in their superior numbers, they showed no wish to retreat. The naval events of the two

last wars, therefore, do not depreciate the art, but those of previous ones afford abundant testimony, that an enemy who was skilful in manœuvring, has often postponed the commencement of, or avoided a battle altogether.

Reverting to the present period, it is hoped that the circumstance of the comparatively large peace establishment of ships of the line recently stationed in the Mediterranean, has afforded opportunities in reference to this matter, that have not passed unheeded: and in justification of the individuals who are alluded to in the former part of this paper, it may be urged, that from whatever cause, and to whatever extent the alleged ignorance may prevail, it is really less imputable to them as a fault, than to the absence of an initiatory system of instruction in periodical operation, and easily available to the wants of the service. The recent revival of the Rodney and Clerk controversy, having excited an unusual interest, renders the present an appropriate juncture for originating such a system. Through this medium, the principles and miniature practice of naval manœuvres might be imparted methodically to young officers, whose minds would thus become so deeply imbued with this kind of knowledge, as to place its (at least) partial retention in the memory beyond the oblivion to which half pay condemns so much useful professional acquirement. That some of the active-minded officers, whom the peace has placed in this vegetating position, would readily embrace the proposed means of instruction, may be inferred from the facts, that the prescribed number of pupils in the Senior Department of the Naval College continues complete; and also from similar alacrity having been shown with respect to the gunnery instruction on board the *Excellent*. It is suggested therefore, that at Portsmouth, Plymouth, and Sheerness, naval manœuvres should be taught at appointed periods of the year, by officers selected for their competency, and attached to the respective flag-ships at those ports. For this purpose, not fewer than twenty of the finest boats of the ships in port should be assembled under the above superintendance, and should proceed to practise the evolutions that are necessary for the guidance of and preservation of order in fleets,—these are few and simple. The French, who were the first people in modern history that reduced this art into a connected form, have swelled their books with a variety of manœuvres, some of which are more ingenious than useful, except as mental exercises, which tend to create a quick conception of resource in situations of difficulty. Every officer, of whatever rank, who had charge of a boat, should in his turn lead a line and direct the proceedings. As combined movements of this nature are simplified in their execution by uniformity of size, and of rate of motion in their elementary parts, it might be advantageous to employ the boats of the Ordinary for this purpose: as they are of the same size and rig, there is probably a greater equality in their sailing than in that of the boats of commissioned ships, and besides they work quicker and with greater certainty than the latter, which are various in both these particulars: being, however, for the most part lug-rigged, and consequently in tacking, unless their sails are dipped very smartly, they are more likely than any others to miss stays, and to gather sternway, an accident that in the exercises might create confusion, it would be a more advantageous employment for these boats, to appro-

appropriate for this use, solely to the half-pay officers, who should be directed to repair on board the depot ship to take charge of them. Officers who reside at the above ports, and keep sailing-boats, should be invited to join the exercises in them. Upon foreign stations the same end may be attained whenever a sufficient number of ships meet in port, and their other duties will permit. The expense of executing this project would be limited to the supply of a few copies of printed manœuvring instructions, diagrams, and signals: and some sets of boats, flags, and pendants, besides a little more wear and tear of the boats.

The harbours above mentioned, and the anchorages in their immediate vicinities, include such a variety of hydrographical features, as would enable the little fleets not only to practise every description of manœuvre, but also to repeat and elucidate all those that are celebrated in naval history. An interesting employment would thus be supplied for the young officers of guardships and others, that would usefully occupy some portion of the time that is now too often wasted, and a foundation might be thus laid for future individual distinction, resulting from the performance of eminent national services.

Since the foregoing observations were written, the guard-ships have been assembled, and report states, for the purpose of sailing upon a cruise of evolution: if this should prove correct, the measure seems to recognise the policy of giving the peace-formed officers some practice in that part of their duty; and the writer would finally remark, with a feeling of sincere respect for the officers who command the ships of the squadron, that the cruise may not prove valueless to them either, for a naval historian of Lord Howe's battle states, that "some of the captains, from having been long unemployed, showed an ignorance of manœuvring."

PROTEUS.

THE EFFECTS OF INEXPERIENCE IN NAVAL AFFAIRS ON
THE PART OF THE ARMY—WITH A REMEDY.

TO THE KING.

SIRE,—As an officer of long standing in your Majesty's service, and having observed frequently in my humble services during the late war, where I felt, and witnessed in others, the awkwardness of a total ignorance of naval affairs, with its consequent inconvenience and ill effects upon the army generally, I am induced to call the circumstance to your Majesty's notice, and at the same time most humbly to point out a remedy.

Here I beg leave to remark, that in giving army officers a knowledge of naval affairs, I do not mean that they should in any respect infringe upon, or usurp the naval officers' profession, which should, and must be, held whole and entire. I should qualify the expression "ignorance of naval affairs," and rather term it "a want of knowing how to act promptly with the navy." My object will better appear when I remind your Majesty of the helpless state of our battalions

during and after a disembarkation, and the danger of such a state of things in the vicinity of an enemy; all owing to the want of practical experience in the officers, not one of whom, perhaps, in fifty, ever served with a floating armament; even field officers, commanding regiments, not knowing how to place their own persons in a boat. This deficiency must be familiar to those who served on coast operations in America, more particularly at New Orleans, and in Holland, &c. &c. &c. I need not take any further pains to establish the truth of my position; the thing is notorious, and is acknowledged by all my military acquaintance.

When it is recollected that our military operations are almost always combined, is it not evident that the army officers, or a portion of them, should be so far acquainted with the sea and the ship, as to be enabled to attend to their men, to the interior economy, and the several important duties connected with the arrangement of their battalions, instead of being, as has been seen too frequently, solely occupied with their own persons and baggage, all owing to the helplessness we feel when embarked on a new element?

To obviate this dangerous inconvenience is the object by which I am induced to offer these remarks, and for which purpose I beg leave most humbly to state to your Majesty, that having lately visited Chatham, I there witnessed the combined duties of the troops of the line with those of the marines: there they take the duties of the garrison, and act together in brigade; and there it at once occurred to me how easy it would be to invest the one branch of your Majesty's service with the practical experience of the other, and that all this may be done without working any great change in long established systems, or of causing the least occasion of jealousy in the minds of the most tenacious for the honour of their several departments or branches of service, and without any other alterations than that of allowing an interchange of commissions between the army and marine officers, as at present exists between the officers of one regiment of the line and those of another. It is clear that this may be effected without any other change whatever in the systems at the Admiralty or Horse Guards. It requires no change of private men, no change of discipline, no giving up or change of authority in either department; and as to the patronage usual in the disposal or interchange of commissions, a satisfactory arrangement may be made without difficulty, to prevent any inconvenience on that head.

It may not be necessary or practicable that all officers should serve at sea, but when the field officer is called upon to consult with the naval commander, a twelve-month's previous service at sea would in many cases enlighten and render him more capable of giving his opinion. Did the present severe duties of the army permit, how desirable would it be that a portion of intelligent men were serving in your Majesty's ships, visiting other countries, and practising on a small scale measures so necessary to be acquainted with in time of war and armaments; such officers returning to the army, either by exchange or promotion, would carry to their messes a fund of useful information, which is at present confined to a branch of the service, whose members have no inducement or opportunity of imparting it. Sire, much, very much more might be urged in favour of this measure, and I firmly believe if

men would divest themselves of prejudice, no argument could be brought against it; but your Majesty, who shows an equal regard for all branches of your service, and who stands high above all prejudice, will best judge.

* I have the honour to be,
Your Majesty's most dutiful subject and servant,
R. Y.

* * There cannot be a question of the deficiency represented by "R. Y.," or of the propriety of remedying it. Without, however, pledging ourselves to the peculiar mode by which our correspondent proposes to obviate the alleged defect, we will add a suggestion it has been for some time our purpose to bring forward at more length—we mean the propriety of making the regular Works and Harbour of Portsmouth, uniting, as that place so eminently does, facilities of illustrating *by practice* the combined or hostile operations both of the sea and land forces, a SCHOOL OF INSTRUCTION for our Troops and Shipping.

Instead of the trite and mechanical details usually prosecuted, with little profit to the individual, in the barrack or upon the deck, why should not the corps, forming in succession the garrison of Portsmouth, be instructed, both officers and men, in the names, nature, and uses of the various Works which form the *enceinte* of that solitary British fortress, and in the qualities and classes of its Ordnance? The officers of Engineers and Artillery stationed there would, we should think, be too happy to be invested with so useful and honourable an occupation. How many officers and soldiers occupy and quit the Garrison of Portsmouth, without knowing the denominations and purposes of its elaborate fortifications, or bestowing a thought upon the acquisition of an elementary knowledge of the first importance to a soldier in the field!

The whole Army and Fleet in Commission might be successively passed through a course of practical instruction and manœuvres at this station,—each arm of the service gaining an insight into the movements and *materiel* of the other; while the details of professional knowledge might be fixed in their attention by sham sieges and fights, landings, repulses, and various manœuvres, in which the services might be combined or opposed; the effect of which would be to invest theory with the value and identity of experience,—to expand the views, profitably employ the time, and excite the emulation of the services,—results which would unquestionably tend to maintain our seamen and soldiers in a fitter state to meet the exigencies of sudden war.

The NAVAL AND MILITARY LIBRARY AND MUSEUM, the definitive establishment of which we have the pleasure to record in our present Number, will, we have no doubt, offer important and extensive facilities to the acquisition of that reciprocal knowledge indispensable to the concert and efficiency of the United Services. As a repository of all mechanical contrivances and details of construction, employed in their various and respective operations, of plans, improvements, and suggestions too numerous for actual adoption, but tending to the grand object of perfecting each system as it were by insensible links of practical ingenuity, this long-desired Institution, exclusive of other equally important advantages, will, we are convinced, prove of the highest utility.

We shall take another opportunity of recurring to this subject.—Ed.

ACTIONS OF THE BRITISH CAVALRY.

THESE appeared a few years ago in one of the Numbers of the Quarterly Review, a paper in which the merits of the British Cavalry were discussed, as compared with that of foreign nations, and the light dragoons were freely censured for inefficiency at the battle of Waterloo. Such sweeping criticisms, even in the pages of that able periodical, are seldom very correct, and their impression is not of a permanent character; but when in so admirable a professional work as that of Colonel Napier, the same sentiments are upheld, the case becomes different, and it is but fair that such a sentence as the following in the work alluded to, should be duly investigated and put to the sure test of positive evidence and correct detail of facts.

Colonel Napier in his Third Volume states,

“The result of one hundred battles and the united testimony of impartial writers of different nations, have given the first place among the European infantry to the British, but, in a comparison between the troops of France and England, it would be unjust not to admit that the cavalry of the former stands higher in the estimation of the world.”

No one will certainly dispute the justice of the first part of this sentence, but it remains to be seen by reference to facts, how far the latter part is correct. The cavalry of England have, it is true, had far fewer opportunities of distinction than the infantry, but it may be confidently asserted, that in nine cases out of ten, where opportunities have been afforded them, from the year 1793 to the battle of Waterloo, they have been successful. Let us proceed to the proof of this assertion by an inquiry into the results of most of the cavalry actions during the late war. To begin with the campaigns of Holland in 1793 and 4, what was the result of the attack of the French on the British camp at Cisoing? The Enniskillens and 16th light dragoons took so active and useful a part in the repulse of the enemy, that they were especially mentioned in the dispatch on that occasion, as having contributed greatly by the spirit of their attack to the success of the day.

A short time afterwards we find a squadron of the Bays under Major Crauford attacking a picket of 150 infantry, of whom they made prisoners 104, leaving the remainder dead upon the spot.

Again at Lanuoy, we hear of Lieut.-Colonel Churchill with two squadrons charging a large body of the enemy, and killing, wounding, or making prisoners 150 of their number.

At Villiers en Couchies, two squadrons of the 15th light dragoons in conjunction with two Austrian squadrons, overthrew more than double their force of French cavalry, and driving them back upon a line of infantry, also broke them, and pursued the whole to the gates of Cambrai, where they found refuge from their victors with a loss of 1200 men and three pieces of cannon: and, indeed, had it not been for a mistake by which the British supports were not sufficiently at hand, the success would have been even more signal and extraordinary.

Such were the principal cavalry affairs of these campaigns, but in several more partial encounters the success of the British was equally remarkable. The next occasion, on which the British cavalry were employed upon the Continent, was the expedition to the Helder, where the peculiar nature of that country prevented much use being made

of their services. One instance was, however, even there afforded them of displaying their superiority, when Lord Paget and Colonel Erskine, at the head of a detachment of the 15th light dragoons, recaptured two guns that had been seized by a much more numerous force of the French cavalry, which had advanced along the sea-side, and which they completely overthrew with considerable loss. We next come to the Peninsular war, and, in referring to the details of the various cavalry actions, it will be the fairest way of proceeding, to quote as frequently as possible from Colonel Napier himself, and placing him in the witness-box, prove from his own evidence, the injustice of the comparison he has so deliberately drawn between the French and British cavalry.

At the battle of Vimiero, Colonel Napier thus narrates the part taken by the small body of cavalry who were present at that victory. "Colonel Taylor with the very few horsemen he commanded, (a squadron of 20th light dragoons,) rode fiercely among the confused and retreating troops, and scattered them with great execution." To this just tribute to the memory of that gallant officer, may be added the testimony of all who beheld his attack, that nothing could be more well-timed and daring: unfortunately, however, the ground was ill-calculated for cavalry, and this small body, led away by the ardour of pursuit, became entangled in difficulties, and being under those trying circumstances, hemmed in and charged by a very superior force under Gen. Margaron, their gallant leader was killed, and the greater part of them destroyed, but not till they had produced an effect upon the enemy greater than could have been expected from twice their numbers.

In the campaign in the north of Spain under Sir J. Moore, the conduct of the cavalry whenever they were engaged, was marked by an energy and spirit which has deservedly obtained the praise of all writers who have recorded that period of the war. The brilliant successes at Sahagun, Mayorga, and Benevente, are too well known to require much comment. On each of those occasions, the light cavalry, under Lord Paget, eminently distinguished themselves by the overthrow of superior numbers of a cavalry which had hitherto in the continental wars been accustomed to a tide of unvaried success. After narrating the affair at Mayorga, Colonel Napier observes, "This was a bold and hardy action, but the English cavalry had been engaged more or less for twelve successive days, and with such fortune and bravery that above 500 prisoners had fallen into their hands, and their leaders being excellent, their confidence was unbounded."

We now proceed to those campaigns which took place under that great chief, who raised the fame of the British soldier to a point far beyond what it had ever attained in the proudest days of our military glory.

The first time in these campaigns that we find much notice of the cavalry is at the passage of the Douro, when Colonel Napier tells us, that—

"Gen. C. Stewart and Major Hervey, impatient of the inactivity of Gen. Murray, charged with two squadrons, and rode over the enemy's rear-guard, as it was pushing through a narrow road, to gain an open space beyond. Laborde was unhorsed, Foy badly wounded; and on the English side Major Hervey lost an arm; and his gallant horsemen, receiving no support from Murray, were obliged to fight their way back with loss."

At the battle of Talavera, the celebrated charge of the 23rd Light Dragoons, has been frequently quoted as an instance of the over impetuosity of the British cavalry; an impetuosity which no doubt led that regiment to almost total destruction; but, before we hastily condemn the charge of the 23rd, let us appeal to Colonel Napier's own account, and the explanatory letter of Sir F. Ponsonby, published in the appendix of the 3rd volume, for the effect upon the general features of the action produced by the rashness of the 23rd; and, if any farther proof be necessary, let us see what is said by Lord Wellington in his Dispatch. After stating that the enemy was collecting large masses for an attack upon the right, he mentions the charge of the 23rd, and observes—"Although the 23rd Light Dragoons suffered considerable loss, their charge had the effect of *preventing the execution of that part of the enemy's plan.*" Now, surely this is a plain and strong testimony; and it is but fair to weigh the advantage obtained, against the losses by which it was purchased. Had the enemy been allowed time for organizing his meditated advance, and had his attack been repulsed by the British infantry on the left, though with far greater loss than what was experienced by the 23rd Light Dragoons, it would still have been considered a successful and glorious result. The 23rd are, therefore, fairly entitled to some degree of praise, for having completely disconcerted this most important attack, upon which no small consequences were evidently dependent. It is perfectly true, that cavalry should as much as possible be husbanded on service, because of the great difficulty of keeping up its efficiency, but no feeling of this sort should ever prevent its being employed, when there are fair grounds for expecting consequences so influential as those which resulted from the charge of the 23rd at Talavera. The attack of formed bodies of infantry is a desperate and hazardous service, but to lay down as a general rule that cavalry should never make such attempts, would be any thing but advisable. The least disorder on the part of the infantry at once renders their array vulnerable, and whether produced by any moral circumstance, by the nature of the ground, or by the artillery belonging to their assailants, the advantage of the cavalry instantly predominates, and the timely blow is certain and decided in its effect.

In retiring upon Leiria, during the retreat upon the lines of Torres Vedras in 1810, the enemy having suddenly pushed on so as to create some confusion, their advanced troops were vigorously attacked by Capt. Cocks, who took very judicious advantage of the ground, and completely held them in check until Gen. Anson's brigade of cavalry, and Capt. Ball's troop of artillery, arrived to his support. Colonel Napier continues the relation of the affair thus—

"The French then forming three columns endeavoured to bear down the British with their centre, while the others turned their flanks. The ravines were, however, difficult to pass; Ball's artillery played well into the principal body, and Anson charging it, as it emerged from every defile, slew a great number; the British lost three officers and about fifty men, the enemy considerably more, and in five hours he did not gain as many yards of ground, although he had *thirty-six* squadrons opposed to *ten.*"

Surely, Colonel Napier's own evidence is, in this instance, very decisive against his comparisons of the French and British cavalry. A

large body of cavalry was engaged on both sides, though with a numerical superiority of more than three to one on the part of the French, not to mention the acknowledged advantage possessed by those who follow, over those who retreat before them. The next mention of the success of our cavalry, by Colonel Napier, relates to such a small force, that we merely allude to it in justice to the gallant but humble individual concerned. "Serjeant Baxter," Col. N. tells us, "at the head of five troopers of the 16th Light Dragoons, surprised and attacked fifty French infantry, making forty-two of them prisoners with the loss of only one of his own men."

A similar instance of courage and conduct at a later period of the war, may be cited in the capture of a field-officer and thirty dragoons of King Joseph's rear-guard, when he retreated from Madrid, by Corporal Hanley, of the 14th Light Dragoons, with a patrol of only eight men of the 14th and Germans. This man is now a serjeant-major in the 14th; and it was not the only feat of the sort that he performed during the war. But to return from this pardonable digression. The first time we find Colonel Napier making any direct reflections upon the cavalry, during the progress of his history, is in his admirable description of Massena's retreat from before the lines of Torres Vedras. He states, that "The cavalry and artillery had been launched against Regnier in his retreat from Belmonte, at daylight, on the morning of March the 30th;" but that Regnier recovered his communications with the loss of 300 prisoners, adding, that "much more might have been done, if the cavalry had been pushed forward with the celerity and vigour the occasion required." Here then, we find the cavalry incurring censure, not for their precipitate rashness, but for over caution. Possibly there may be some justice in the blame imputed to them; but to any man acquainted with the nature of the country in which these transactions took place, it must be evident that no little circumspection was necessary in attempting to push forward cavalry and guns, without the immediate support of their own infantry, into passes and defiles where that of the enemy might with little danger to themselves, have inflicted such severe losses upon their mounted pursuers. After all, the fact of 300 prisoners having been captured, proves the pursuit not to have been so extremely slack as is represented.

It is not very difficult *after* the occurrence to pronounce where boldness should have ended, or at what point it assumes the character of temerity, but at the moment of action, it requires no small judgment to form such decided opinions. Colonel Napier thus relates an instance at the combat of Sahugal, of unwarrantable rashness on the part of the enemy.

"A squadron of French cavalry surmounted the ascent, and with incredible desperation, riding up to a wall, behind which some of our infantry were posted, were in the act of firing their pistols over it, when a rolling volley laid nearly the whole of them lifeless on the ground."

A very similar instance of reckless audacity occurred at the battle of Orthez, where a French squadron, riding furiously up a lane, were exterminated to a man by the fire of our infantry posted upon an overhanging bank above them. Here are strong cases then, as regards the French cavalry, of the fatal effects of rash attacks; and it must further be observed, that, if we weigh these two cases in the proper scale, it will be found that the advantage would not have at all counter-

balanced the extreme hazard of their attempts, even if the French had in either case been successful.

The next cavalry engagement took place near Campo Mayor, about the end of March. Colonel Napier, after noticing the retreat from the town, of 1200 cavalry and 3 battalions of infantry, some horse artillery and 13 battering guns, the whole under Gen. Latour Maubourg, thus describes the action which took place during the pursuit of the Allied troops.

“ Colonel Colborne was on the right, at a considerable distance from the enemy, but Colonel Head, with the 13th Light Dragoons, was on the left close to them, and supported by Colonel Otway, with two squadrons of the 7th Portuguese; the heavy cavalry was in reserve; and while in this state, the French hussars, suddenly charging with a loose rein from behind their infantry, fell, some on the Portuguese and some on the 13th Light Dragoons. So fiercely did these last on both sides come together, that many men were dismounted by the shock, and both parties pierced clean through to the opposite side, then re-formed, and passed again in the same fearful manner to their own ground; but *Head's troopers rallied quicker than the French*, and riding a third time closely in upon them, overthrew horse and man, receiving, at the same time, the fire of the infantry squares. Nevertheless, they galloped in upon the battering train, hewed down the gunners, and drawing up beyond the French line of march, barred their way, in the expectation that the heavy cavalry would also fall on; but Beresford would not suffer the latter to charge, and the French infantry returned to their guns, and resumed their march, but the 13th and the Portuguese continued the pursuit in a rash and disorderly manner, even to the bridge of Badajoz, and being repulsed by the guns of the fortress, were followed by Mortier in person, and lost some prisoners. Of the Allies 100 men were killed or hurt, and about 70 taken. Of the enemy about 300 suffered, one howitzer was taken, and the French Colonel Chamorin was slain in single combat by a trooper of the 13th.”

After a few observations on Lord Beresford's conduct on the occasion, Colonel Napier adds—

“ The 13th were reprimanded, perhaps justly, for pursuing too rashly without orders, but *the unsparing admiration of the whole army consoled them.*”

Three weeks had not elapsed after this affair before we again find Colonel Napier making honourable and deserved mention of this same gallant regiment.

“ Two French regiments of cavalry advancing from Llerena to collect contributions, had reached Usagre, where meeting with the British cavalry, they were suddenly charged by the 13th Dragoons, and followed for six miles so vigorously, that 300 were killed or taken without the loss of a man on the part of the pursuers.”

In an affair which took place on the 16th, Colonel Napier seems to attach some blame to the cavalry, for having failed in cutting off a body of infantry who were escorting a convoy into Ciudad Rodrigo. It would be absurd, no doubt, to defend a want of proper enterprise on the part of cavalry, because enterprise is almost the soul of the service, and without it cavalry would be nearly an useless appendage to an army in the field. Great objects cannot be gained without sacrifice, and in the case under consideration, the question seems to be merely how far the possible result of the attack, if successful, would have repaid the heavy loss which must always attend the charges of cavalry

upon a perfectly well-formed and steady body of infantry, such as the escort of this convoy appears to have been. Some officers have strongly contended that a determined resolution on the part of cavalry, will ensure their success against the squares of infantry. It has been said by a writer in the *U. S. Journal*, for instance, that upon that occasion when Colonel Talbot, of the 14th Light Dragoons, lost his life in charging a body of French infantry, the cavalry gave up their attack just at the moment of success, when their horses were close to the bayonets; but surely this writer forgets that much more depends on the horse than on his rider, at such a moment; and that when once thoroughly confused and terrified, the animal becomes quite unmanageable, and no efforts on the part of his rider can force him forward, or indeed prevent his turning short round, breaking the ranks, and flying from the danger which is before him. It should also be recollected, that the fire of the infantry will inevitably produce some degree of confusion in the ranks of the cavalry, before they can possibly reach the point of conflict, and the fall of a very few men and horses, in an advance of this desperate nature, is liable to produce a disorder, which neither courage nor discipline can prevent or remedy.

In his observations upon the battle of Albuera, Colonel Napier, speaking of the cavalry, says General Lumley handled the "Allied squadrons with skill and courage, and drew all the advantage possible from his situation;" a just tribute to the admirable judgment with which that excellent officer, commanding a force greatly inferior in number, not only held Latour Maubourg in check, but at the worst crisis of that tremendous battle, when Colonel Colborne's brigade, by being too hastily brought into action by Gen. W. Stewart, were overwhelmed by the French cavalry, "perceived the mischief," as Colonel Napier tells us, "and sending four squadrons out upon the lancers, cut many of them off."

Here then is an instance not of mere courage for attack, but of that cool forethought and deliberate resolution so necessary for the preservation of order and steadiness, and without which the efforts of cavalry must always depend upon the luck and chances of the moment.

But a week had elapsed after the bloody battle of Albuera, when we again find Colonel Napier bearing testimony to the good service of Gen. Lumley and his cavalry.

"From Llerena a detachment was sent to drive away a Spanish partisan corps, which had cut off his (Soul's) communications, and at the same time Latour Maubourg was directed to scour the country beyond Usagre; this led to an action; for that town, built upon a hill, and covered towards Los Santos by a river, with steep and rugged banks, had only one outlet by the bridge on that side, and when Latour Maubourg approached, Lumley retired across the river. The French light cavalry then marched along the right bank, with the intention of crossing lower down, and thus covering the passage of their heavy cavalry; but, before they could effect this object, Gen. Bron rashly passed the river with his two regiments of dragoons, and formed them in line just beyond the bridge. Lumley was lying close behind a rising ground, and when the French had advanced a sufficient distance, the British artillery under Lefebre opened upon them, and the 3rd dragoon guards and 4th dragoons charged them in front, while Madden's Portuguese fell upon their flank. They were overthrown at the first shock, and fled towards the bridge, but that being choked by the rest of their cavalry advancing to their support, the fugitives turned to the right and left, endeavouring to save themselves among the gardens along the river side; there they were pur-

sued and sabred, till the French, on the opposite side, seeing their distress, opened a fire of artillery and carbines, that obliged the British to discontinue the attack. Forty killed, above 100 wounded, and eighty prisoners, were the fruits of this brilliant action of Gen. Lumley's."

No comment is needed upon this affair; the rashness and disorder of the French cavalry and their leaders were as conspicuous as the cool and steady manner in which they were received and discomfited by Gen. Lumley and his cavalry. A remark was made at the time by those who were engaged, which it may be well to notice. Only about one third of the French who were struck down by the sabre, were killed outright; while, on the part of the English, the proportion of killed was much greater than that of the wounded, a circumstance from which it was reasonably inferred that the French sabre was a more destructive weapon than that of our cavalry. The swords of the latter were bad enough for cutting with the edge, but for giving point they were almost quite useless, while those of the French were admirably adapted for pointing, and altogether a far superior weapon. A much better pattern than the old one has been lately approved, it is said, for the British cavalry, and there can be little doubt that although the Englishman is more inclined to strike or cut than to point at his adversary, yet there are many occasions when the soldier, if properly instructed in the advantages of so doing, as well as in the method, would use the point with as destructive effect as the soldier of any other nation.

This affair at Usagre is the last which Colonel Napier has noticed in his third volume, and we now take leave of him as an evidence, having, as it is hoped, redeemed our pledge of proving, by his own statements, the injustice of his comparative condemnation of the British cavalry, in the sweeping sentence of which they have such reason to complain. We shall next proceed to detail from the most authentic sources within our reach, farther actions reflecting credit upon their conduct and courage in the field during the remainder of the war.

(To be continued.)

THE SERVICES OF THE LATE ADMIRAL SIR JOHN KNIGHT, K.C.B.

MR. KNIGHT first commenced his career in the navy, on board the *Tartar*, frigate, under the command of his father, who was made a Captain, May 8th, 1756, and died a Rear-Admiral. On the 1st of June 1758, the *Tartar* left Portsmouth for the French coast, with an expedition under the orders of Commodore Howe, against Caucalle, Cherbourg, St. Maloes, &c. which destroyed several of the enemy's ships. Mr. Knight afterwards was in the squadron under the orders of Lord Anson, which convoyed Her Majesty Queen Charlotte to Harwich, in Sept. 1761. After the peace took place, Mr. Knight was employed in surveying the North American coast, and on the 25th of May 1770, was promoted to the rank of Lieutenant; and in 1775, was second of the *Falcon* sloop, Capt. John Linzee. The *Falcon* was one of the vessels that covered the attack on Bunker's Hill, after which Lieut. Knight was made prisoner of war in endeavouring to bring off an American vessel that had been driven on shore. An exchange of prisoners taking place the following year, Lieut. Knight joined Lord Howe, who, in February 1777, appointed him to command the *Haer-*

lem of 12 guns, in which he captured several of the enemy's small vessels. In 1778 the *Haerlem* narrowly escaped capture by the French fleet, under the command of Count d'Estaing. Lieut. Knight was soon after removed into the *Eagle*, the flag-ship of Lord Howe, in which he returned home in October.

Lieut. Knight's next appointment was to the *Barfleur*, the flag-ship of Rear-Admiral Sir Samuel Hood, (afterwards Viscount Hood,) on the Leeward Island station, by whom he was on the 21st Sept. 1781, promoted to Post-Captain, and to command the *Shrewsbury*, in the room of Capt. Mark Robinson. Capt. Knight continued under Sir Samuel Hood's orders, by whom he was appointed to command his flag-ship the *Barfleur*; and after the defeat of Count de Grasse, presented the sword of that commander to Sir Samuel Hood. A few months previous to the peace of 1783, His Royal Highness Prince William Henry (his present Majesty) did duty as Midshipman on board the *Barfleur*.

The *Barfleur* being paid off in consequence of the peace, Capt. Knight remained upon half-pay until his appointment to the *Victory*, fitting for the flag of Lord Hood, in consequence of the expected war with Spain in 1790.

Soon after the commencement of the war with France, Lord Hood was appointed Commander-in-Chief in the Mediterranean, and Capt. Knight was again appointed to the *Victory*, and was present at the several affairs of Toulon and at Corsica, and returned home in December 1794; when in May the following year, Lord Hood was ordered to strike his flag, which was the last time his Lordship held a command. Capt. Knight continued in the *Victory*, and in the action with the French fleet, 13th July 1795, Rear-Admiral Robert Mann had his flag on board. In December the same year, Admiral Sir John Jervis, (afterwards Earl St. Vincent,) hoisted his flag in the *Victory*, on which occasion Capt. Knight returned from the Mediterranean, and was soon after appointed to the *Montague*, attached to the North Sea fleet, under the orders of Admiral Duncan, which ship bore a conspicuous part in the disgraceful mutiny that subsequently took place. Happily for the country this mutiny was suppressed, and proper examples made of the ringleaders. The misguided men fully retrieved their character in the action which afterwards took place off Camperdown, 11th Oct. under the orders of Admiral Duncan, against the Dutch fleet under De Winter.

After this brilliant action, Capt. Knight had a command on the Irish coast; served in the Channel fleet, and in the Mediterranean; and in August 1779, commanded the advanced squadron before Brest, during which time several successful captures were made by the *Montague's* boats of the enemy's small vessels.

A promotion of Captains taking place 1st Jan. 1801, Capt. Knight became Rear-Admiral of the Blue. In April 1805, Admiral Knight hoisted his flag on board the *Lucca* for the Mediterranean, and succeeded Admiral Sir Richard Bickerton, in the command at Gibraltar, where his flag was hoisted on board the *Guerrier* guard-ship, which was the last command he held.

In the promotion that took place 9th Nov. 1805, after the action off Trafalgar, Admiral Knight was promoted to Vice-Admiral; and on the 4th Dec. 1813, to that of Admiral.

For his services in the action off Camperdown, Admiral Knight was honoured with a gold medal, and on the 2nd Jan. 1815, was created a Knight Commander of the Bath.

On the 16th June last, Sir John Knight expired, after a very short illness, at Woodend, Hampshire, aged 83 years.

THE SERVICES OF THE LATE VICE-ADMIRAL
VISCOUNT TORRINGTON.

THIS nobleman was the eldest son of John, the fifth Viscount Torrington, brother to Admiral Byng who was shot in pursuance of the sentence of a Court-Martial, 14th March 1757, on board the *Monarque*, 74, at Portsmouth.

Mr. George Byng was born in London, 5th January 1768, and entered the Naval service when scarcely more than ten years of age, as Midshipman on board the *Thunderer*, 74, Capt. the Hon. B. Walsingham, and was in the action between Admiral Keppel and the Count D'Orvilliers on the 27th July 1778. Mr. Byng subsequently served in the *Alarm*, with Capt. Sir Richard Pearson; and in the *Active*, Capt. T. Mackenzie. In the latter ship, Mr. Byng sailed for the East Indies, where he joined the *Superb*, the flag-ship of Vice-Admiral Sir Edward Hughes, and was in the actions with M. Soufferin. After the *Superb*, Mr. Byng served in the *Defence*, with Commodore Andrew Mitchell; and on arriving at Portsmouth in the end of 1785, passed his examination for a Lieutenant. He next joined the *Jupiter* of 50 guns, Commodore W. Parker, at the Leeward Islands, from whom he subsequently received a commission as Acting Lieutenant; and afterwards served in the *Trusty* with Rear-Admiral Sir John Laforey, who had assumed the command on that station, in the room of Commodore Parker. In September 1790, a commission was sent out, promoting Mr. Byng to the rank of Lieutenant, and he returned home in the *Shark* sloop-of-war.

In 1791, Lieut. Byng was appointed to the *Illustrious*, Capt. C. M. Pole, and afterwards removed into the *Druid* frigate. He was afterwards appointed to the *Impregnable*, but from ill health, was not in the action of the 1st of June, under the orders of Lord Howe.

In October 1794, Lieut. Byng was promoted to Master and Commander, and to the *Ferret* sloop-of-war; and during the absence of Sir Edmund Nagle, acted as Captain of the *Artois* frigate; and in June 1795, was further promoted to Post-Captain, and to the *Redoubt* of 20 guns. His next appointment was to the *Mercury* frigate, under the orders of Vice-Admiral Sir James Walmer, at Newfoundland; and was there when the French Admiral Richery appeared before the settlement with seven sail-of-the-line, and three frigates, having 2000 troops on board, who from the resistance they experienced by a force considerably inferior, abandoned their project. In 1797, Capt. Byng was appointed to the *Galatea* frigate, in which he captured a French corvette of 14 guns, and several armed vessels. In May 1802, Capt. Byng resigned, through ill health, the command of the *Galatea*; and on the renewal of the war with France was appointed to the *Texel*, and became commanding officer of the block ships stationed on the Kentish coast.

In August 1804, Capt. Byng was appointed to the *Malabar* of 50

guns; and in the following year to the *Belliqueux*, in which he was present at the surrender of the Cape of Good Hope to the forces under Capt. Sir Home Popham and Major-Gen. Sir David Baird; after which Capt. Byng convoyed the East India ships to Madras, and formed one of the squadron under the orders of Vice-Admiral Sir Edward Pellew, and was at the destruction of several vessels of war and merchant ships in Batavia Roads.

In 1809, an armament was fitted out at Bombay, for the purpose of taking possession of Roderiguez Island, on which occasion Capt. Byng hoisted a broad pendant. In this affair the military were commanded by Lieut.-Colonel Keating, and the object was eminently successful, and owing to this enterprise, the capture of the Mauritius and Bourbon took place.

The *Belliqueux* sailed from Macao Roads the 14th of February 1811, having seven of the East India Company's ships under convoy, and after experiencing very tempestuous weather, reached St. Helena the 15th of May, and on being joined by the *Chiffone* and *Menelaus* frigates, and several Indiamen and other ships, sailed for England, and safely arrived in the Downs the 8th of August. The *Belliqueux* being found unfit for service was paid off at Chatham, and Capt. Byng was soon after appointed to the *Warrior*, 74, and was subsequently employed in the North Sea. In December 1812, died Capt. Byng's uncle, George, the fourth Viscount Torrington, upon which the gallant Captain's father succeeded to the title, but who enjoyed it only fourteen days, when he also died, and Capt. Byng became Viscount Torrington. The Dutch soon after threw off the yoke which had been imposed upon them by Buonaparte, and declared for the Prince of Orange, when, on the 25th of November 1813, his Serene Highness embarked in the Downs, on board the *Warrior*, accompanied by the Earl of Clancarty, and landed at Schwelung the 30th following.

After this service, Lord Torrington convoyed a fleet of merchant vessels to the West Indies, during which time a promotion took place, and his Lordship in consequence became, June 4th 1814, a Rear-Admiral of the Blue, and relinquished the command of the *Warrior*, and 19th of July 1821, was made a Vice-Admiral.

The command of the Leeward Island station becoming vacant in 1819, was offered to Lord Torrington, but which his Lordship did not accept. His Lordship had been for a long time in an alarming state of health at his residence, Yotes Court, Kent, and after enduring very great and acute suffering, died there the 18th of June 1831.

The late Viscount Torrington succeeded his father 8th of January 1813. His Lordship married, first, February 8th 1793, Elizabeth, daughter of Philip Langmede, of Howgate House, Plymouth, Esq. and by her (who died August 21st 1810,) had issue, Lucy Elizabeth, born July 11th, 1794; and a son born May the 23rd, 1796, who died December 1st the same year. His Lordship married, secondly, October 1811, Frances Harriet, second daughter of Rear-Admiral Sir Robert Barlow, Knt. then Commissioner of His Majesty's Dock Yard at Chatham, and niece to Sir George Hillaro Barlow, Bart. and G.C.B. and had issue, George, the present Viscount, born September 9th 1812, and other children.

THE NIGER.

THE announcement of the arrival of the enterprising travellers in the interior of North Africa, the brothers, Lander, after a successful termination of their arduous task, must be highly gratifying to all the admirers of geographical discovery, and to the friends of humanity, after the sacrifice of so many valuable lives in the attainment of the truth respecting the outlet of the mysterious stream. From the brief account already transpired, it appears that the great river hitherto known to Europeans by the name of the Niger, debouches into the Bight of Benin, in the vicinity of Cape Formosa, thereby verifying the opinions of Mr. Reichard, the German, and the writer of an interesting letter from British Accrah, dated 7th Jan. 1824, from on board the brig *Castor*; the latter stating his belief that the Niger empties itself by a great Delta, of which, the Rio Formosa or Benin is the western, and the Rio del Rey, the eastern branch, with several rivers between them from the same source.

But I am inclined to believe that the Joliba, Quolla, Gulhi, (as it is severally called in its course,) or river which passes Jenné, Boussa, Nyfée, and Fundah, is not the ancient Niger mentioned by Leo; but that the Quolla, Quorra, Yeou, or river passing Sakatoo and Kano, and falling into the lake Tsad of Bornu, is the ancient stream of the African writer.

The lake Tsad, under a different name, has long been known; the historical dictionary* of France states Borno as "a city and kingdom in the Nigritia, with a desert and lake of the same name, the country of the ancient Garamantes. It is said these people live in common, and bring up as their own such children as resemble them. The Lake Borno (Tsad) is celebrated because it is *crossed by the Niger*;" this *Niger* is not that of Park, but that of Denham and Clapperton, *i. e.* the Yeou.

The statement of the Shary river flowing *out of* the lake Tsad, and falling into the Niger (of Park) at Fundah, appears to be incorrect, as Major Denham embarked on that river, and distinctly states that it *falls into* the lake (flowing from the south) by two branches, and ran at the rate of five miles an hour. Some other river must be meant, and is confounded with the Shary (of Denham) which name may probably in the Fellata language mean merely a river; if so, it is probable to be the stream mentioned by the Major as issuing from the south-east side of the lake and supposed to flow to the Nile, but which perhaps is a continuation of the Yeou, running first to the south-east, and then turning to the west, discharges into the Niger (of Park) at or near Fundah; the range of high land whence the Shary is said to take its rise, south, or west of the Tsad in the vicinity of Musfia, about the 9th or 10th degree of north latitude, may be no obstruction to the stream finding its way at the basis of those mountains to the westward; this is the only way we can reconcile the account obtained by Lander in his former and present travels, of the supposed Shary running *from* the lake of Bornu and falling *into* the Niger.

* Moreri Dict. Historique.

If we are correct in our inference, agreeable to the description given in Dict. Hist., the Yeou, like the Rhone through lake Lemana at Geneva, passes into lake Tsad at one angle, and out at another, continuing its course until it meets the Niger of Park; by which a very large portion of the interior of Africa becomes insulated: indeed, in the absence of any positive *proof* of the Yeou or Sakatoo river being distinct from the Joliba, or Niger of Park, we may conjecture with some probability that both, in the first instance, proceed from the same source, in lat. $8^{\circ} 20'$ N. and long. $9^{\circ} 20'$ W. in the Soliman country, and that at the lake Debée a separation takes place, one (the Niger of Park) flowing to the ESE., and the other (the Sakatoo river) to the E. and reunite again at Fundah, the latter passing through the Tsad. A Mahomedan Sheik, who had been a great traveller, informed Mr. Dupuis that the Joliba was a distinct river from the Quorra, both, however, issuing from lake Dehy or Zeby, but he does not mention their reunion. Another conjecture with equal probability is, that the Niger of Park may throw off a branch to the eastward, which may be identified with the Shary (the source of which is not known) and falling into the Tsad reconcile the account given by Lander. Horniman's son told Major Denham that the Quorra of Nyffée (a branch of it more probably) went off to the southward, (and eastward) ran between two ranges of mountains, passed Loggun, where it was called Shary, and fell into the lake Tsad. If either or both these should prove true, another extraordinary feature will be added to the character of the long-famed Niger.

X.

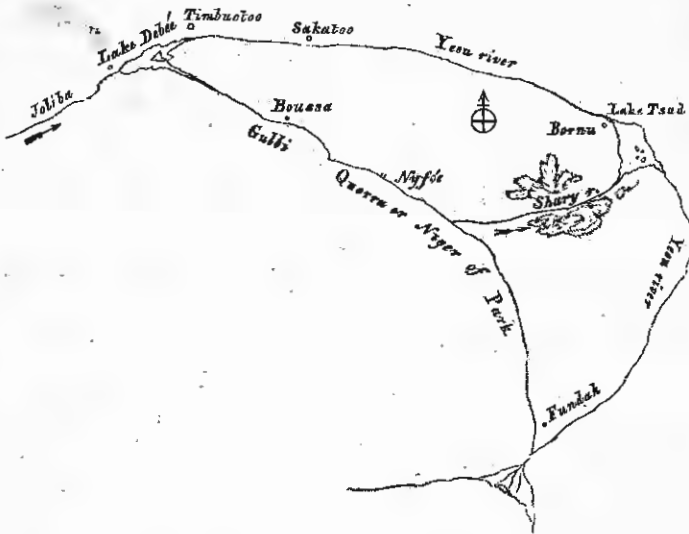

OBSERVATIONS ON NAVAL GUNNERY

THE term "*Point-blank*" so generally used, and yet so difficult to be defined, has been a great bar to improvement in the practice of Naval Gunnery. Even if such a distance as that which is termed "*point-blank range*" actually existed, the method of indicating it in our printed tables would still remain defective. We are there told, merely, that the *point-blank range* of a gun is so many yards, but we are not told for what height of the gun above the plane on which the distances are reckoned this range is adapted. Now it is evident that the higher the gun is placed, the farther it will range; the distance being reckoned on the horizontal plane beneath. Thus, the calculated ranges of a gun placed three, six, and twelve feet above the water, are found to be respectively about 170, 230, and 330 yards; the axis of the gun being horizontal.

A very slight consideration will also show that it is altogether erroneous to suppose, with these tables, that to hit a mark at or within the distance which is called "*point-blank range*," we should point directly at it (the gun being supposed disparted). The instant a shot quits the muzzle of the gun, it commences to leave the direction in which it was projected, being acted upon by the force of gravity; it is therefore plain that it cannot strike the object at the point at which aim was taken. That this difference does not exist merely in theory, will be made apparent by an examination of the following table, which shows the results of experiments made at Ferrol, by Admiral Churruca some years ago, and which has been extracted from M. Charpentier's translation of his work on Naval Gunnery.* Although these depressions are much greater than those observed at the present day, which is probably owing to the increased strength of gunpowder, yet even admitting that they are erroneous by one half, they serve to show that it is important to notice them in practice. We also learn from the table the ratio existing between the depressions of round and double-headed shot; this ratio appears to be very nearly as 2 : 3.

TABLE I.

Showing the depressions of round and double-headed shot observed by Churruca.

1st Station. Butt distant two Spanish cables = 440.5 English yards.					2nd Station. Butt distant three Spanish cables = 660.7 English yards.				
Round.		Double-headed.			Round.		Double-headed.		
Calibre Spanish.	Number of Trials.	Shot struck too low Mean.		Number of Trials.	Number of Trials.	Shot struck too low Mean.		Number of Trials.	Calibr Spanish.
36	10	21.42	31.55	20	15	51.08	75.83	11	36
24	10	19.93	32.06	15	20	47.57	71.48	15	24
18	10	20.70	31.49	15	16	48.04	72.22	15	18
12	10	19.71	30.41	12	30	47.54		0	12

* Instruction sur le Pointage de l'Artillerie, &c. traduite de l'Espagnol par M. Charpentier.

The first column indicates the nature of the gun used in the experiments; the second, the number of discharges from which were deduced the mean depressions of round-shot, which are given in the third; the fourth column shows the mean depression of double-headed shot, and the fifth the number of trials from which they were determined. At the second station the quantities are indicated in like manner.

The depressions are given in English feet. One Spanish foot=0.98 English. One Spanish pound=1.03 English.

In 1830, some experiments of a like nature were carried on at Portsmouth, by Captain the Hon. George Elliot, then commanding H. M. Ship Victory. From their results he came to the conclusion that it would be advisable, in order to counteract the effect of the depression of the shot, to fix what is called the point-blank sight, so that when pointing by it, the piece in reality should be at a certain elevation. He fixed the amount of this elevation at $0^{\circ} \cdot 20'$ for long guns; at $0^{\circ} \cdot 30'$ for carronades.

The following extract is taken from Capt. Elliot's letter to the Lords Commissioners of the Admiralty on the subject.

"The only guns I had an opportunity of using for these experiments, were a 32-pounder carronade, and a nine feet 18-pounder gun using common wads (not grommet.) The shot were unequal in size, but not more so than may be expected in actual practice, and the fall of the shot was taken from an average of about ten shot from each gun at each distance.

	Distances of target.	Shot struck too low.	Calculated depression being the tangent of $30'$ for carronade; of $20'$ for gun.		Error with sight as proposed.	Exact elevation required to hit the mark.	
			Ft.	In.			Ft.
32-Pounder carronade, single shot, full charge, one wad	Yards.						
	100	2	4	2	6	+ 0 2	0 28
	200	4	10	5	0	+ 0 2	0 29
	250	6	5	6	5	+ 0 0	0 30
300	10	6	7	6	- 3 0	0 31	
18-Pounder gun, single shot, full charge, one wad	100	1	8	1	8	+ 0 0	0 20
	200	3	4	3	4	+ 0 0	0 20
	250	4	4	4	2	- 0 2	0 21
	300	6	0	5	0	- 1 0	0 24

Thus I recommend point-blank distance to be 250 yards, and the sights to be set on carronades at $0^{\circ} \cdot 30'$ elevation; on long guns at $0^{\circ} \cdot 20'$ elevation for this nominal point-blank."

The advantages of this arrangement are very great, for although strictly speaking, a different elevation is required for each distance, even when within what is called point-blank range; yet it must be nearly impossible, when under a close heavy fire, to resort to any means for determining distances accurately, and even if that were done, it would interfere too much with the rapidity and precision of fire so necessary under those circumstances to be continually altering the sight. However, the superiority of a fixed sight for close quarters is generally acknowledged, and I wish now only to insist on the advantage of the adoption of Capt. Elliot's modification.

It may be remarked that the top-sight in general use in the navy, is raised above the axis of the piece somewhere about a foot, so that strictly speaking, the centre of the shot should strike a foot below the point aimed at. The sight might easily be adopted to correct this error by computing the angle subtended by one foot, (supposing that to be the space betwixt the gun's axis and the sight,) at various distances, but it may be safely neglected in practice. Indeed, for short distances, it is provided for, by the adoption of the alteration mentioned above.

In number II. III. of the "Annales Maritimes for 1831," M. Roche has investigated the subject of pointing naval ordnance, and founding his calculations on experiments made at Brest in 1824, with a French 30-pounder gun, (equivalent to about thirty-two and a half English,) has given various tables of ranges, which I shall transcribe.

The charges used were one-third and one-fourth of the weight of the shot, and M. Roche remarks, that the increase of range due to the larger charge, was about one-thirty-second part of the whole.

The initial velocity which M. Roche obtains is 1230 feet per second: now the usual velocity with which shot are discharged in our practice from long guns, is generally between 1500 or 1600 feet per second; consequently, the following ranges may be considered as erring in defect for the corresponding elevations.

I have, however, thought it better not to increase them, as in the first place the ratio of the range to the initial velocity is not correctly known; * and secondly, as I conceived it to be the safer side to err on, owing to the great probability of using in practice gunpowder which is deteriorated by keeping, or shot whose windage is increased from the same cause.

The French measures have been reduced to English, assuming the French foot to be equal to 1.0658 English. Table II. gives various angles of elevation and the corresponding ranges in yards.

TABLE II.

Showing angles of elevation and the corresponding ranges in yards; the gun being 4.25 yards above the horizontal plane on which the ranges are measured.

-1° 0'	-0° 40'	-0° 20'	0° 0'	0° 20'	0° 40'	1° 0'	1° 20'	1° 40'	2° 0'	2° 20'	2° 40'	3° 0'
176.1	215.6	268.3	338.8	425.3	525.3	633.4	746.0	859.3	971.1	1080.4	1186.6	1288.9
The negative sign indicates depression.												

Table III. is formed from Table II. by simple proportion, and gives the elevations corresponding to various distances.

TABLE III.

200	300	400	500	600	700	800	900	1000	1100	1200	1300
-0° 48'	-0° 11'	+0° 14'	0° 35'	0° 54'	1° 12'	1° 29'	1° 47'	2° 6'	2° 24'	2° 42'	3° 2'

Tables II. and III. are adapted to throw a shot to strike the enemy's

* Assuming the ranges to vary as the square roots of the initial velocities, those given in this paper should be increased by about their eighth part.

hull at the water-line, which is assumed to be nearly thirteen feet below the gun; the following table shows the requisite elevation when the point to be struck is in the same horizontal plane as the gun.

TABLE IV.

Showing the angles of elevation required to strike a mark situated in the same horizontal plane as the gun.

100	200	300	400	500	600	700	800	900	1000	1100	1200	1300
0° 11'	0° 23'	0° 35'	0° 47'	1° 1'	1° 15'	1° 30'	1° 46'	2° 2'	2° 18'	2° 34'	2° 52'	3° 9'

The three foregoing tables* can only be used when we possess some means of measuring the angle of elevation, such as a pendulum, or by our knowing the point in the enemy's hull, which is at the same height from the water as the gun, and pointing at it after having adjusted the sight to the proper angle.

To modify them so that they may be used when we possess no such means, we must calculate the angle subtended by the height of the gun at the given distance, and add it to the tabulated angle from Tables II. and III. then adjusting the sight to this newly obtained angle, aim must be taken directly at the water-line, when it is obvious that the axis of the piece will be at the proper elevation. These corrections are in the following table.

TABLE V.

Showing the corrections to be added to the angles from Table III.

200	300	400	500	600	700	800	900	1000	1100	1200	1300
1°13'	0°49'	0°36'	0°29'	0°24'	0°21'	0°18'	0°16'	0°15'	0°13'	0°12'	0°11'

Thus, for example, if it be wished to strike the water-line of a ship distant 800 yards, the gun being placed 4.25 yards above the water, we must seek in Table III. for the proper elevation which we find to be 1° 29'. In Table V. we find the corresponding correction to be 0° 18'. Their sum equalling 1° 47' is the angle which must be adjusted on the sight, to enable us to direct the gun properly by pointing at the water-line.

In the same manner, we find that to strike a point the same height as the gun, the distance being 800 yards, we must adjust the sight to 1° 46' + 0° 18' = 2° 4' and then take aim also at the water-line.

It will be seen that the angle from Table III. corrected is nearly identical with that from Table IV. whence we may conclude that the latter table will serve for the purpose of pointing to hit any object, situated thirteen feet below or above the gun; the error committed by using it being very far within the uncertainty of practice.

Should the guns be only fitted with a fixed sight, it will be useful, in-

* These tables are adapted for long guns. From some late practice with a 32-pounder carronade, charge one-twelfth the weight of the shot, its ranges reckoned on the same horizontal plane as the gun, appear to be nearly as follows:

100	300	500	700	900	yards.
0°..14'	0°..37'	1°..14'	2°..5'	3°..10'	elevation.

deed necessary, to calculate tables which are known by the rather uncouth name of "Tangent Practice Tables," similar to those given by Churruca,* and more lately by Sir Howard Douglas.† Putting e for the elevation from Table IV., e' for the fixed elevation of the "point-blank sight," d for the distance, and h for the height of the gun above the water, then the height above the enemy's water-line of the point to be aimed at $= x = d \cdot \tan. (e - e') + h$. Aiming, therefore, at a point in one of the masts (the dimensions of which may be estimated pretty accurately) which is x feet above the water-line, the shot should strike h feet above that line. Should it be wished to strike higher or lower than that point by a few feet, the aim must be altered by nearly the same quantity.

There is an additional advantage (already noticed by Sir Howard Douglas †) in aiming by the enemy's masts, because even if the shot strike above or below the intended aim, the chance of taking effect is of course increased.

Table VI. shows the values of x , in feet, the fixed sight being at an elevation of $0^\circ 20'$.

TABLE VI.

Showing the heights above the water-line to be aimed at, sight fixed at $0^\circ 20'$.

200	300	400	500	600	700	800	900	1000	1100	1200	1300
13.3	16.7	22.2	30.6	41.5	55.5	72.8	93.1	115.8	141.4	172.0	204.6

From Table I. we learnt that the ratio of the depressions of round to double-headed shot was as 2 : 3. Now, from the best published experiments, the range of the former to the latter is about as 3 : 2. Hence it appears the depressions are inversely as the ranges.

Following the same analogy, it is not improbable that the depression of grape-shot (by which is meant the depression of the centre of effect) is double that of round-shot, the ranges being nearly as 1 : 2. Increasing, therefore, the values of $x - h$ in these ratios, we may calculate the elevations for double-headed and grape-shot for various distances, by reversing the process given above. Therefore putting b equal to the increased value of $x - h$; $\tan. (e - e') = \frac{b}{d}$.

TABLE VII.

Showing the elevations for double-headed and grape.

	200	300	400	500	600	700	800	900
Double-headed	$0^\circ 24'$	$0^\circ 42'$	$1^\circ 1'$	$1^\circ 21'$	$1^\circ 43'$	$2^\circ 5'$	$2^\circ 29'$	$2^\circ 53'$
Grape	$0^\circ 26'$	$0^\circ 50'$	$1^\circ 14'$	$1^\circ 42'$	$2^\circ 10'$	$2^\circ 40'$	$3^\circ 12'$	$3^\circ 44'$

No use, however, can be made of these or any other tables of a like nature, unless we are provided with the means of measuring distances

* Instruction sur le Pointage de l'Artillerie, &c.

† Treatise on Naval Gunnery.

‡ Treatise on Naval Gunnery, First Edition, p. 231.

accurately at sea. If the dimensions are known of the masts of the vessel, whose distance is required, the process usually employed is simple. Measure the angle a subtended by any known height h , then

Distance = $\frac{h}{\tan. a}$. Many persons when measuring this angle bring

down the reflected image to the water-line, and not to that part of the vessel corresponding in height with their own eye; and although this error needs only mentioning to be acknowledged, the fact that it is not unfrequently committed may serve as an apology for noticing it.

It often happens that the dimensions of the distant vessel are unknown, and this inconvenience suggested the following method which is believed to be new.

Measure the angle subtended by the space betwixt the horizon and the water line of the distant vessel; calling this angle a and the dip of the horizon δ , it is plain that $a + \delta$ is the angle subtended at the distant vessel by the height of the observer's eye, which is known.

Calling it h , Distance = $\frac{h}{\tan. (a + \delta)}$. A small correction is due for the spherical form of the earth, which for this purpose may be safely disregarded.

It must be recollected that all the foregoing tables of ranges depend on the accuracy of the Brest experiments, and also, that as they were made with a different species of ordnance than is in use in the British service the results are not immediately applicable to our practice; the ranges too, although given for angles of elevations which are tabulated to minutes, have no pretensions to that degree of accuracy.

It is often remarked, when attempts are made to introduce improvements in Naval Gunnery, that it is quite useless refining too much, as the errors arising from the ship's motion are so great as to render all others trifling in comparison. To reply to this we should recollect that we can only reach perfection by distinguishing between unavoidable inaccuracies and the errors arising from imperfect knowledge of the subject.

In conclusion, I shall take leave to remark on the vast importance of the foregoing subject in a national point of view, and to venture to express a hope that before long, experiments may be instituted on a larger scale than heretofore, which may afford to naval officers some data on which they may regulate the practice of the various natures of guns with which men-of-war are armed. They themselves often have it in their power to make trials, which if recorded faithfully, with all the attendant circumstances (even those which may appear at the moment to have little or no connexion with the subject) might add materially to our stock of knowledge, the more so as these experiments would be made under circumstances similar to those in which their ships would be fought.

D.

REVIEWS AND CRITICAL NOTICES.

COLONEL NAPIER'S HISTORY OF THE WAR IN THE PENINSULA—
VOL. III.*

In the notices which we have been heretofore called upon to take of Colonel Napier's History of the Peninsular War, we have endeavoured, as far as possible, to divest ourselves of every thing like partiality, favour, or affection, and to speak of the performance in such terms as its merits alone seemed to require. Upon these grounds, and upon these grounds only, we have pronounced it to be by far the ablest and most eloquent account that has yet been given of any portion of the great contest. Clear in its details, animated in its descriptions, and abounding with marks of deep (we wish that we could add always of) sober thought, no person, however unaccustomed to unravel the intricacies of military history, can find himself at a loss in following its narrative; while the professional reader discovers at almost every page some great lesson recorded, from the study of which he rises, if not "a better," certainly "a wiser man." This is very high praise we are aware,—so high, indeed, that we could scarcely name a second work of the kind on which we should be disposed to bestow it,—yet it is fully and richly earned by Colonel Napier. We do not say that he is the best narrative-writer of his day—we do not profess to go along with him in all his arguments, nor even to assent to the whole of the postulates on which his reasoning is founded. We do not acquit him of faults either in style or arrangement,—for the former, though vigorous and clear, is not wholly devoid of affectation, nor is the latter always such as we imagine that it might have been,—but we repeat, that take it for all in all, the History of the War in the Peninsula stands, and deserves to stand, at the head of all similar productions which have yet appeared, either in England or elsewhere. No doubt other accounts of the Peninsular war will be given,—some of them, (one of them at least,) advance still loftier pretensions to public favour,—but we are greatly deceived if any other shall succeed in consigning Colonel Napier's elaborate volumes to the oblivion which must necessarily overtake the great mass of similar performances.

Entertaining an opinion so exalted of Colonel Napier's work, and as a necessary consequence of the genius and talents of its author, it is exceedingly painful to us that we are compelled to notice in the volume now under review, proofs more and more glaring of the baneful influence of party and political prejudice over minds the most honourable and the most cultivated. If there lives the man whom we could have expected to triumph over such feelings, that man is Colonel Napier. Unconnected, as far as we know, by family or personal ties with any political faction whatever, and educated in a school from which the curse of faction is for the most part shut out,—well read, moreover, in classic lore, and of course not unaccustomed to weigh the effects of party spirit both in public and in private, we cannot so much as divine a cause why he should descend from the proud eminence of impartiality, and surrender up a judgment naturally sound and clear, to the guidance of a principle for which we are at a loss to devise an appropriate name. It is to no purpose that Colonel Napier may assure us of his intention to advance no statement which shall not be fully borne out by facts. We do not doubt this—we are sure that he never wrote a line or uttered a sentence which he himself did not believe to be correct. We are convinced

* History of the War in the Peninsula and in the South of France, from the year 1807 to the year 1814. By W. F. P. Napier, C.B. Colonel H. P. 43rd regiment, and Member of the Royal Swedish Academy of Military Sciences.—Vol. iii.

that he is as far above the control of selfishness and envy, as any man living,—and that the most uncalled-for assertions which he has hazarded, all spring from a determination not to sacrifice truth on *any* altar. But we must still charge him with making assertions which he was not warranted to make. It were very idle,—to use no harsher term, in Colonel Napier, to set himself up in array against *all* the most illustrious statesmen whom England has produced. Who can suppress a smile when he reads in the pages of this military history, a sweeping condemnation of the public conduct of such men as Pitt, and Canning, and the late Lord Londonderry,—not, be it observed, with reference to isolated acts performed by one or all of them, but applied to the whole of their proceedings as members of the King's Cabinet? Nor are the Whigs treated with greater mildness by this, their advocate elsewhere. My Lord Grey comes in for a few hard knocks, well merited doubtless, but bestowed in a temper the reverse of bland. Now, with all due submission to Colonel Napier's superior talents, we must be permitted to say, that such things done as he has done them, exhibit proofs of a very defective taste. They remind us of a silly body of a Scotch divine, with whom we were in our youth acquainted, and who used to threaten to favour the world with a volume of sermons, because Hooker, Barrow, and Warburton, were superficial writers.

But it is not, we lament to say, while discussing political topics only, that Colonel Napier indulges a spirit which, for his own sake, we wish that he had stifled. His treatment of more than one brother soldier is unnecessarily harsh; his style of canvass when applied to the deeds of others is positively unjust. With Lord Beresford we have no more communication than Colonel Napier. We do not pretend to regard him as a rival to the Duke of Wellington, nor yet as a match in stratagem for Soult; but we must protest against the virulent tone which the historian of the Peninsular War has assumed while tracing his Lordship's career both in Portugal and Spain. With respect to the account which Colonel Napier has thought fit to give, of the causes to which Lord Beresford owed his advancement in the Portuguese army, we can only say, that it does not appear to be borne out by facts. Lord Beresford was not preferred, through the influence of his family connexions, to any officers possessed of stronger personal claims. He was not one of four rival applicants for the situation, nor did he know that the appointment lay within his reach till it had actually been pressed upon him; he was selected, as well in consequence of the reputation which he had previously acquired in arms, as on account of the knowledge which he was known to possess of the Portuguese language. In like manner, Colonel Napier's *exposé* of the proceedings of Marshal Beresford when in command of the Portuguese army, abounds with inaccuracies. He assumes data which he has no right to assume; reasons upon these data after a fashion peculiar to himself, and then jumps to a conclusion that Lord Beresford displayed neither talent nor decision, in any situation where an opportunity for such display was afforded. We could point out various passages both in the second and third volumes of his work, confirmative of these assertions, but it is unnecessary; for the author of a clever pamphlet, entitled "Strictures on certain Passages of Lieut.-Colonel Napier's History," has saved us the trouble. With respect, again, to the narrative of the operations which preceded the battle of Albuera, and the account of the battle itself, we can only say, that we deeply deplore the temper in which they are given. Not one movement was, according to our historian, made aright. There were delays, hesitation, ignorance, gross carelessness, all exhibited by the General-in-Chief; nay, the very officers commanding brigades and regiments, if they come not in for their own share of reprobation, obtain, at least, no renown from the chronicler of their deeds. God knows how it happened that the English were not annihilated, for if we may trust this account of the business, scarcely a man did his duty.

If we be asked whence this disposition to general censure arises, we must confess our inability to answer the question. We can understand why Lord Beresford should find little favour in Colonel Napier's eyes; but what the commanding officers of corps have done to offend the gallant historian we are ignorant. Nor is it only when discussing the *demerits* of the Albuera corps, that Colonel Napier is liberal of half praise. We are assured that neither Picton nor Craufurd were officers of a very high order,—that Colborne possessed merely a “natural aptitude for war;” and that others, of whom the world has hitherto been accustomed to think favourably, have scarcely earned its praise.

So far we have written under the influence of profound sorrow, not un-mixed with mortification; for it is truly distressing to contemplate the diligence with which an accomplished and able historian has laboured to detract from the high character of his work. Had Colonel Napier succeeded in mastering this single enemy to his own greatness,—had he overruled his prejudices, given somewhat more of kindness to his general tone, and where he could not praise, abated as far as possible his censure, he would not have lowered the station of his performance one iota, while he would have gained for it a far more extended approval than it ever can obtain, even among such as give implicit credit to its assertions. It is a great mistake to suppose, that the truth of history may not be preserved, yet contemporary feelings spared. There are many delicate ways of telling men that they are not heroes, besides the blunt statement delivered in its plainest terms; we wish for his own sake, not less than for that of others, that Colonel Napier had selected any one of them.

The portion of the war embraced within this third volume, extends from the autumn of 1809 up to the month of June 1811. Of the three books which compose it, the first (the IX.) and a part of the second, are occupied entirely with a detail of the operations in different provinces of Spain. The marches and skirmishes, the attacks and defence of posts in the Asturias, Galicia, Arragon, Catalonia, &c. are all described with characteristic force and perspicuity, while full justice is done, in more than one instance, to the gallantry and skill even of the Spaniards. We notice this part with the more pleasure, because Colonel Napier has been accused, (most unjustly as we know,) of underrating the exertions of the people of the Peninsula in their own cause; but we cannot pause to do more,—for the defence of Portugal calls for all our spare time and space.

The readers of Colonel Napier's History will recollect, that the second volume closed with a brilliant description of the battle of Talavera, and a summary of the retrograde movements consequent on that battle. By this proceeding, forced upon him by the imbecility and misconduct of his Allies, the British General separated himself entirely from the Spaniards; and after resting his overwrought columns for a space along the banks of the Guadiana, assumed more healthy cantonments in the north-eastern portion of Portugal. Here he employed himself during the winter months in arranging those gigantic plans, on the accomplishment or frustration of which the fate of Europe may be said to have depended. He demanded such reinforcements from home as should enable him to take the field with 30,000 British troops; he required that full authority over the military force of Portugal should be given to him; and he insisted that such orders as he should find it necessary from time to time to issue, should be obeyed both by soldiers and civilians. It was not without a great deal of difficulty, and after repeated exercise of that firmness which forms so marked a feature in his intellectual portrait, that Lord Wellington succeeded in obtaining a compliance with these requisitions. The British Cabinet, indeed, came forward to the extent of its disposable means, both with men and money,—though the unhappy expedition to Walcheren had reduced both to a low ebb; but Portugal, a prey to faction, and scarcely true to herself, endea-

voured to evade the wishes of her defender. In the end, however, the influence of Lord Wellington prevailed, and he was nominally endowed with full authority over both the army and the people.

It was high time that the British General should be placed in such a situation, as would leave him something like free scope for the exercise of his great military genius. Napoleon, victorious in Germany, was daily pouring into Spain fresh corps,—while the Spaniards, beaten at all points, presented nowhere a point of resistance, beyond that which a few detached partisan and Guerilla bands might be able to offer. Lord Wellington was not ignorant of all this. He saw the storm gathering, and though it was of course impossible to anticipate where it would first burst, he took the most effectual steps for opposing it, let it come whence it would. While his mixed army of British and Portuguese watched, in several divisions, along the border-line, he himself marked out, and set a multitude of people to work upon, the entrenchments at Torres Vedras, well aware that there was no position more in advance of Lisbon which could be long maintained against superior numbers, and equally satisfied that there, with the sea open to him, he could defy the whole power of France. At the same time, roads of communication were formed, bridges constructed, and every facility afforded for the simultaneous movements of the divisions, so soon as the enemy's dispositions should render such a measure necessary; and both Ciudad Rodrigo and Almeida being stored and prepared, it remained only to wait the issue of events in patience.

The tale of Massena's gathering, and of the attack and defence of Ciudad Rodrigo, has been too often told to require repetition here. Let it suffice to say, that Colonel Napier, by the vigour and originality of his descriptions, has continued to invest it with fresh interest, and that he has cleared up more than one point, which was heretofore involved in a good deal of mystery. But the following description of an affair which took place soon after the city fell, is a great deal too striking to be omitted. The reader will probably recollect, that while Rodrigo held out, Gen. Crawford, with the light division, was posted as far in advance as the further bank of the Azava. When Rodrigo fell, Crawford retired a couple of miles to the wood of Alamedas, from whence he shortly moved, after a delay of some days, skirmishing all the way, to another wood near Fort Conception. He had received positive orders not to hazard a battle, but to withdraw behind the Coa so soon as the enemy should threaten; but Crawford was an obstinate man. Having braved Massena hitherto, he could not brook the idea of flying before him, and here, with something less than 3000 men, he ventured an encounter with five times his own numbers. We give the description of that battle in our author's energetic language.

“COMBAT OF THE COA.”

“Crawford's whole force under arms consisted of four thousand infantry, eleven hundred cavalry, and six guns, and his position, one mile and a half in length, extended in an oblique line towards the Coa. The cavalry pickets were upon the plain in his front, his right on some broken ground, and his left resting on an unfinished tower, eight hundred yards from Almeida, was defended by the guns of that fortress; but his back was on the edge of the ravine forming the channel of the Coa, and the bridge was more than a mile distant, in the bottom of the chasm.

“A stormy night ushered in the 24th of July. The troops, drenched with rain, were under arms before day-light, expecting to retire, when a few pistol-shots in front, followed by an order for the cavalry reserves and the guns to advance, gave notice of the enemy's approach; and as the morning cleared, twenty-four thousand French infantry, five thousand cavalry, and thirty pieces of artillery were observed marching beyond the Turones. The British line was immediately contracted and brought under the edge of the ravine; but meanwhile Ney, who had observed Crawford's false disposition, came down with the stoop of an eagle. Four thousand

horsemen and a powerful artillery swept the plain. The allied cavalry gave back, and Loison's division coming up at a charging pace, made towards the centre and left of the position.

"While the French were thus pouring onward, several ill-judged changes were made on the English side; part of the troops were advanced, others drawn back, and the 43rd most unaccountably placed within an enclosure of solid masonry, at least ten feet high, situated on the left of the road, with but one narrow outlet about half-musket shot down the ravine. While thus imprisoned, the firing in front redoubled; the cavalry, the artillery, and the *çaçadores* successively passed by in retreat, and the sharp clang of the 95th rifle was heard along the edge of the plain above. A few moments later, and the 43rd would have been surrounded; but that here, as in every other part of this field, the quickness and knowledge of the battalion officers remedied the faults of the general. One minute sufficed to loosen some large stones, a powerful effort burst the enclosure, and the regiment, reformed in column of companies, was the next instant up with the riflemen; there was no room to array the line, no time for any thing but battle; every captain carried off his company as an independent body, and joining as he could with the 95th or 52nd, the whole presented a mass of skirmishers, acting in small parties and under no regular command; yet each confident in the courage and discipline of those on his right and left, and all regulating their movements by a common discretion, and keeping together with surprising vigour.

"It is unnecessary to describe the first burst of French soldiers. It is well known with what gallantry the officers lead, with what vehemence the troops follow, and with what a storm of fire they waste a field of battle. At this moment, with the advantage of ground and numbers, they were breaking over the edge of the ravine, their guns ranged along the summit, played hotly with grape, and their hussars, galloping over the *glacis* of Almeida, poured down the road, sabring every thing in their way. Ney, desirous that Montbrun should follow this movement with the whole of the French cavalry, and so cut off the troops from the bridge, sent five officers in succession to urge him on, and so mixed were friends and enemies at the moment, that only a few guns of the fortress durst open, and no courage could have availed against such overwhelming numbers. But Montbrun enjoyed an independent command, and, as the attack was made without Massena's knowledge, he would not stir. Then the British regiments, with singular intelligence and discipline, extricated themselves from their perilous situation. For falling back slowly, and yet stopping and fighting whenever opportunity offered, they made their way through a rugged country tangled with vineyards, in despite of their enemies, who were so fierce and eager, that even the horsemen rode in amongst the enclosures, striking at the soldiers as they mounted the walls or scrambled over the rocks.

"As the retreating troops approached the river, they came upon a more open space; but the left wing being harder pressed, and having the shortest distance, arrived while the bridge was still crowded and some of the right wing distant. Major M'Leod, of the 43rd, seeing this, rallied four companies on a hill just in front of the passage, and was immediately joined by a party of the 95th, and at the same time, two other companies were posted by Brigade-Major Rowan, on another hill flanking the road, these posts were thus maintained until the enemy, gathering in great numbers, made a second burst, when the companies fell back. At this moment the right wing of the 52nd was seen marching towards the bridge, which was still crowded with the passing troops; M'Leod, a very young man, but with a natural genius for war, immediately turned his horse round, called to the troops to follow, and, taking off his cap, rode with a shout towards the enemy. The suddenness of the thing, and the distinguished action of the man, produced the effect he designed; a mob of soldiers rushed after him, cheering and charging as if a whole army had been at their backs, and the enemy's skirmishers, astonished at this unexpected movement, stopped short. Before they could recover from their surprise, the 52nd crossed the river, and M'Leod, following at full speed, gained the other side also without a disaster.

"As the regiments passed the bridge, they planted themselves in loose order on the side of the mountain. The artillery drew up on the summit, and the cavalry were disposed in parties on the roads to the right, because two miles higher up the stream there were fords, and beyond them the bridge of Castello Bom, and it was to be apprehended that, while the 6th corps was in front, the reserves, and a divi-

sion of the 8th corps, then on the Agueda, might pass at those places and get between the division and Celarico. The river was, however, rising fast from the rains, and it was impossible to retreat farther.

"The French skirmishers, swarming on the right bank, opened a biting fire, which was returned as bitterly; the artillery on both sides played across the ravine, the sounds were repeated by numberless echoes, and the smoke, rising slowly, resolved itself into an immense arch, spanning the whole chasm, and sparkling with the whirling fuzes of the flying shells. The enemy gathered fast and thickly; his columns were discovered forming behind the high rocks, and a dragoon was seen to try the depth of the stream above, but two shots from the 52nd killed horse and man, and the carcasses, floating between the hostile bands, showed that the river was impassable. The monotonous tones of a French drum were then heard, and in another instant, the head of a noble column was at the long narrow bridge. A drummer and an officer in a splendid uniform, leaped forward together, and the whole rushed on with loud cries. The depth of the ravine at first deceived the soldiers' aim, and two-thirds of the passage was won ere an English shot had brought down an enemy; yet a few paces onwards the line of death was traced, and the whole of the leading French section fell as one man! Still the gallant column pressed forward, but no foot could pass that terrible line; the killed and wounded rolled together, until the heap rose nearly even with the parapet, and the living mass behind melted away rather than gave back.

"The shouts of the British now rose loudly, but they were confidently answered, and, in half an hour, a second column, more numerous than the first, again crowded the bridge. This time, however, the range was better judged, and ere half the distance was won, the multitude was again torn, shattered, dispersed, and slain; ten or twelve men only succeeded in crossing, and took shelter under the rocks at the brink of the river. The skirmishing was renewed, and a French surgeon coming down to the very foot of the bridge, waved his handkerchief and commenced dressing the wounded under the hottest fire; nor was his appeal unheeded: every musket turned from him, although his still undaunted countrymen were preparing for a third attempt. The impossibility of forcing the passage was, however, become too apparent, and this last effort, made with feebleness and less energy, failed almost as soon as it commenced."

Of the many and complicated movements which followed this action, it is of course impossible for us to give even a meagre outline. We must refer such as are curious (and who is not?) to the pages of Colonel Napier's work, where they will find the tale told with a degree of spirit and perspicuity never surpassed and rarely equalled. For ourselves we must be content to say, that the unfortunate capture of Almeida compelled Lord Wellington to commence his retreat towards the lines, much sooner than he either expected or desired; that the retreat was, however, conducted with the utmost regularity and order,—that Massena, deceived by the reports of his Portuguese partisans, took the only road in pursuit which could have hindered him from pressing the rear of the British while in march, and hence that Lord Wellington was enabled to take up the position of Busacco, at his leisure, after being joined by Hill, and the divisions which had hitherto kept ground on the opposite side of the Tagus. Not that the British General moved all this while upon a velvet carpet. On the contrary, the Government of Portugal no sooner heard of his retrogression, than they began as usual to clamour and cabal, while the country people, rendered desperate, only half obeyed the edicts, which, though stern at the moment, proved in the end the means of their country's deliverance. Many mills were thus left standing, much corn and other provisions escaped destruction, and the country was surrendered to the enemy only half a desert.

On the 23rd of Sept. the headmost corps of the Allied army began to enter the position of Busacco. On the 24th, the enemy appeared in force, and skirmished with the pickets in front of Mortagoa,—a movement which induced the light division to fall back a few miles; and on the 25th, Crawford had again well nigh renewed the scene of the Coa, by hazarding a separate battle. The cavalry skirmishers, indeed, were already exchanging

pistol-shots, when Lord Wellington suddenly came up, and taking the personal command of the division, ordered it to retreat. Nor was there a moment to lose; for the enemy, with incredible rapidity, brought up both infantry and guns, and fell on so briskly, that it required all the skill of the General, and all the steadiness of the 52nd and 95th Rifles, to hinder the division from being forced into a serious engagement. A series of rapid and beautiful movements, however, a sharp cannonade, and an hour's march, brought every thing in good order to the grand position; while almost at the same moment, the opposite ridge was crowned by the enemy's masses, and the batteries began to play into the English ranks as they ascended the height. Meanwhile Reynier, taking the left-hand route, along which a Portuguese battalion had retired, arrived at St. Antonio de Cantara, in front of the third division; and before three o'clock, 40,000 French infantry were embattled on the two points, and the sharp musketry of the skirmishers arose from the dark-wooded chasms beneath.

There were at this time not more than 25,000 of the Allies in line, and even of these large numbers were moving from place to place, with the haste which always accompanies the taking up of ground not previously examined. Large intervals, moreover, showed themselves between the divisions, and the nature of the position, a ridge—not a table-mountain,—gave proof that few reserves could be concealed. Ney, who marked all this, was eager to attack. He sent off a dispatch to Massena, who remained a long march in the rear, with strong representations of the state in which matters stood; but the Prince of Esling was not willing that any decisive step should be taken, till he was himself at hand to direct it. It was well for the Allies that Ney's wishes were not accomplished. Massena did not reach this point till noon on the 26th, by which time the whole British and Portuguese army was assembled, and then it was too late to hope for success in any offensive operations, except by dint of superior daring and prowess.

How the battle of Busacco was fought and won, it is not necessary to describe. It was a fierce and obstinate combat, but, from first to last, the enemy struggled against disadvantages, and hence their loss exceeded ours by a proportion of three to one. Nevertheless, the ridge thus gallantly maintained, was of no value. Massena, filing to his right, was enabled to turn it, and as a necessary consequence the retreat was renewed. It was a melancholy movement; for the army, as policy and real humanity required, swept back with them towards the lines every living and dead thing that was valuable, and hence the columns were preceded and followed by, and not unfrequently intermixed with, crowds of wretched country people and droves of domestic animals. Meanwhile several daring exploits were performed by the British corps, which Lord Wellington left to operate upon the flanks and rear of the enemy. Coimbra, after receiving 5000 French sent into its hospitals, was surprised by Colonel Trant, and all the invalids, with their guards and attendants, were made prisoners. Frequent skirmishes, moreover, took place, between the rear-guard of the English and the French advance; and once the light division narrowly escaped a heavy loss. But at last the lines, which had been so long and so carefully constructed, were entered; the army halted on the plain below, and there was a sort of lull like that which in the natural world follows, for the most part, the fury of the hurricane.

We have spoken freely of the style which Colonel Napier has deemed it expedient to select as most appropriate to the expression of his opinion touching the merits of Lord Liverpool's Cabinet. It is certainly not remarkable either for humility or candour, nevertheless we are as fully convinced as he, that nothing but the firmness of Lord Wellington saved Europe at this momentous crisis. Colonel Napier has, with more of generosity than judgment, endeavoured to set up a parallel between Lord Wellington and Sir John Moore. By all means. It is far, very far, from our wish to detract from the renown of the illustrious dead, whose memory we profoundly venerate—but since our author has forced the task upon us, we can

only entreat any thinking man—we do not say any soldier—to contrast the tone of Lord Wellington's correspondence from the lines, with that of Moore at any given period in his public career. With the latter there was but one consideration, which never ceased to engross attention, namely, how are the British troops to escape? It was the burthen of his song, that the cause was desperate, that no reinforcements ought to be sent out, but that the means of transport should be provided, and held in constant readiness. How different the language held by Wellington! No doubt he was too prudent to neglect any matter, or to leave out of his calculations any chance. He therefore provided amply for the worst, but in direct opposition to the opinions of the ablest of his staff, and almost in defiance of the Government at home, he insisted that the Peninsula might yet be defended. Would the heroic Moore have acted thus,—he who ordered back troops actually sent to him, and desponded even when the Cabinet was most sanguine? And here we cannot but lament that Colonel Napier should, by an imprudent comparison, force upon us and upon the country in general, a remembrance of the one weak point in his hero's character—his want of just confidence in himself.

Our limits will not permit us to attempt more than a reference to the work itself, in regard to the nature of the lines, and to the proceedings of the belligerents during the period in which they were occupied. Both are admirably described, but especially the operations in Andalusia, the circumstances attending the blockade of Cadiz, the battle of Barossa, the series of blunders, and shameful cowardice which threw Badajoz into the hands of Soult. For ourselves we cannot afford to turn our eyes one moment from the splendid picture which is given of the breaking up of Massena, at Santarem, and his subsequent evacuation of Portugal. Yet even here we must lay a violent restraint upon our own inclinations. Greatly as we could wish to follow the historian march by march, we hold it impracticable to do so; but we must gratify the reader by transcribing for him the following spirited account of the affair, or skirmish, at Sabugal. It was full of blunders from beginning to end, no doubt brought on needlessly, and absolutely defeating a well-laid plan of the General in Chief. Yet it merits the high encomium bestowed upon it by Lord Wellington, "that it was one of the most glorious actions that British troops were ever engaged in."

"COMBAT OF SABUGAL.

"The morning was so foggy, that the troops could not gain their respective posts of attack with that simultaneous regularity which is so essential to success; and in the light division no measures were taken by Sir William Erskine to put the columns in a right direction: the brigades were not even held together, and he carried off the cavalry and the 3rd caçadores without communicating with Colonel Beckwith. This officer, who commanded the first brigade, being without any instructions, halted at a ford to await farther orders, and at that moment a staff officer rode up, and somewhat hastily asked, why he did not attack? The thing appeared rash, but with an enemy in his front he could make no reply, and instantly passing the river, which was deep and rapid, mounted a very steep wooded hill on the other side. Four companies of the 95th led in skirmishing order, and were followed by the 43rd regiment; but the caçadores and the other brigade, being in movement to the true point, were already distant, and a dark heavy rain setting in rendered it impossible for some time to distinguish friends or foes. The attack was thus made too soon, for, owing to the obscurity, none of the divisions of the army had reached their respective posts. It was made also in a partial, disseminated, and dangerous manner, and on the wrong point; for Reynier's whole corps was directly in front, and Beckwith, having only one bayonet regiment and four companies of riflemen, was advancing against more than twelve thousand infantry, supported by cavalry and artillery.

"Scarcely had the riflemen reached the top of the hill, when a compact and strong body of French drove them back upon the 43rd; the weather cleared at that instant, and Beckwith at once saw and felt all his danger; but he met it with a heart that nothing could shake. Leading a fierce charge he beat back the enemy,

and the summit of the hill was attained, but at the same moment two French guns opened with grape at the distance of a hundred yards, a fresh body appeared in front, and considerable forces came on either flank of the regiment. Fortunately, Reynier, little expecting to be attacked, had for the convenience of water, placed his principal masses in the low ground behind the height on which the action commenced; his renewed attack was therefore up hill; yet the musketry, heavy from the beginning, now increased to a storm; the French sprung up the acclivity with great clamour, and it was evident that nothing but the most desperate fighting could save the regiment from destruction.

"Capt. Hopkins, commanding a flank company of the 43rd, immediately ran out to the right, and with admirable presence of mind seized a small eminence, close to the French guns and commanding the ascent up which the French troops turning the right flank were approaching. His first fire was so sharp, that the assailants were thrown into confusion; they rallied and were again disordered by the volleys of this company; a third time they endeavoured to form a head of attack; when Hopkins with a sudden charge increased the disorder, and at the same moment the two battalions of the 52nd regiment, which had been attracted by the fire, entered the line. Meanwhile, the centre and left of the 43rd were furiously engaged and wonderfully excited; for Beckwith wounded in the head, and with the blood streaming down his face, rode amongst the foremost of the skirmishers, directing all with ability, and praising the men, in a loud cheerful tone.

"The musket-bullets flew thicker and closer every instant, but the French fell fast, a second charge cleared the hill, a howitzer was taken, and the British skirmishers were even advanced a short way down the descent, when small bodies of French cavalry came galloping in from all parts, and obliged them to take refuge with the main body of the regiment. The English line was instantly formed behind a stone wall above; yet one squadron of dragoons surmounted the ascent, and, with incredible desperation, riding up to this wall, were in the act of firing over it with their pistols, when a rolling volley laid nearly the whole of them lifeless on the ground. By this time, however, a second and stronger column of infantry had rushed up the face of the hill, endeavouring to break in and retake the howitzer which was on the edge of the descent and only fifty yards from the wall; but no man could reach it and live, so deadly was the 43rd's fire. Meanwhile two English guns came into action, and the two battalions of the 52nd charging upon the flank of the assailants, vindicated the right of the division to the height. A squadron of French cavalry, which had followed the columns in their last attack, then fell in amongst the 52nd men, extended as they were from the circumstances of the action, and at first created considerable confusion, but it was finally repulsed.

"Reynier, convinced at last that he had acted unskillfully in sending up his troops piece-meal, put all his reserves, amounting to nearly six thousand infantry with artillery and cavalry, in motion, and outflanking the division on its left, appeared resolute to storm the contested height. But, at this critical period, the fifth division passed the bridge of Sabugal, the British cavalry appeared on the hills beyond the enemy's left, and Gen. Colville with the leading brigade of the third division issuing out of the woods on Reynier's right, opened a fire on that flank, which instantly decided the fate of the day. The French general hastily retreated upon Rendo, where the sixth corps, which had been put in march when the first shots were heard, met him, and together they fell back upon Alfayates, pursued by the English cavalry. The loss of the allies in this bloody encounter, which did not last quite an hour, was nearly two hundred killed and wounded, that of the enemy was enormous; three hundred dead bodies were heaped together on the hill, the greatest part round the captured howitzer, and more than twelve hundred were wounded; so unwisely had Reynier handled his masses, and so true and constant was the English fire. Although the principal causes of this disproportion undoubtedly was, first, the heavy rain which gave the French only a partial view of the British, and secondly, the thick wood which ended near the top of the hill, leaving an open and exposed space upon which the enemy mounted after the first attack; yet it was no exaggeration in Lord Wellington to say, "that this was one of the most glorious actions that British troops were ever engaged in."

The affair of Sabugal occurred on the 3rd of April 1811, and was the last skirmish of any importance in which Massena was involved, previous to the evacuation of Portugal. He was not followed beyond the position, but re-

tired into cantonments in and around Salamanca, having lost five-and-thirty thousand men since he quitted that city less than a year before.

Having thus effected that which "to others it appeared incredibly rash and vain to attempt," Lord Wellington lost no time in seeking to remedy the faults of others. As soon as the retreat of Massena was fully ascertained, he had dispatched Marshal Beresford with a strong corps to act on the banks of the Guadiana, and to recover, if possible, the fortresses of Campo Mayor and Badajos. We will not follow the Marshal in this movement, partly because we have already exceeded the space which we had allotted to ourselves, and partly because we are unwilling to repeat censures, which have not once been recorded without extreme pain to ourselves. It is sufficient for our purpose if we say, that Beresford, having surprised Montbrun, during the march of a convoy, and secured Campo Mayor, took quarters at Elvas, where the materials necessary for further operations were collected. The troops had, however, actually passed the Guadiana when Lord Wellington himself reached Elvas, and something like a plan of campaign was arranged with Castaños and Blake. But there was no leisure granted for maturing this plan. Massena was again in movement towards the Agueda, for the relief, as was generally understood, of Almeida, and Lord Wellington hurried back to observe him.

Perhaps there is no portion of this eloquent volume which the general reader will peruse with more intense interest than that which describes the movements of the two armies prior to the battle of Fuentes d'Onore, during the progress of that battle, and subsequent to it. We would not willingly take away from his delight by spoiling, in an endeavour to abridge, a narrative so beautiful; but we must, as a specimen of the remainder, transcribe our author's description of an affair not less brilliant than any throughout the war. Colonel Napier is speaking of a critical moment, when the enemy's superior horse had borne down our feeble cavalry, and the infantry and guns stood upon a plain, exposed to all their fury.

"Houston's people, being thus entirely exposed, were charged strongly, and Capt. Ramsay's horse-artillery was cut off and surrounded. The light division instantly threw itself into squares, but the main body of the French horsemen were upon the seventh division, ere a like formation could be effected: nevertheless the troops stood firm, and, although some were cut down, the Chasseurs Britanniques, taking advantage of a loose wall, received the attack with such a fire that the enemy recoiled. Immediately after this, a great commotion was observed amongst the French squadrons; men and officers closed in confusion towards one point where a thick dust was rising, and where loud cries and the sparkling of blades and flashing of pistols, indicated some extraordinary occurrence. Suddenly the multitude was violently agitated, an English shout arose, the mass was rent asunder, and Norman Ramsay burst forth at the head of his battery, his horses breathing fire and stretching like greyhounds along the plain, his guns bounding like things of no weight, and the mounted gunners in close and compact order protecting the rear. But while this brilliant action was passing in one part, the enemy were making progress in the wood, and the English divisions being separated and the right wing turned, it was abundantly evident that the battle would soon be lost, if the original position was not immediately regained."

With this extract we shall conclude our notice of a volume, than which we again declare, that we have met with none in any language more full of beauties, and very few, we grieve to add, so disfigured with faults. We break off thus abruptly, because were we to proceed further, we must necessarily touch upon the delicate ground of "Albuera's strife," a subject not only open to much and violent controversy, but not yet, as far as we know, fairly explained. That the battle cost dear, all parties are agreed; and that the victory was as much owing to the stubborn valour of the British troops, as to the skill displayed by their leaders in handling them, even the officer in command has never denied,—but how far Lord Beresford lies open to the violent charges brought against him by Colonel Napier, we are not prepared

to say. We are given to understand, however, that his Lordship is even now preparing a statement in reply to that of our author.

There is too much manliness in the character of Colonel Napier to permit us to doubt that he will interpret our observations in the spirit of justice and duty which prompts them. It may be even useful to him to know that we represent upon this subject the feelings and opinions of a large portion of his brother soldiers. It is, we need not say, infinitely more agreeable, as well as habitual to us, to swell his well-earned trophies, by adding our deep-felt tribute to his eminent merits as a writer—a soldier—and a man.

CAPTAIN HALL'S FRAGMENTS OF VOYAGES AND TRAVELS.*

THIS book is modestly recommended by the author to the use of *young persons chiefly*, but we believe that few persons of any age, however advanced, will peruse it without being conscious of a salutary spice of admonition silently penetrating to some distempered corner of their heart, and correcting a latent evil. It evinces throughout a delicate perception of the consequences of our conduct as it regards the feelings of others, which bears more particularly upon the duties of the higher stations of life.

To persons in power, its pages are a vehicle of important hints and judicious advice; while to the young and subordinate, instruction is conveyed through the fascinating medium of lively narrative and interesting adventure; thus insensibly implanting in youthful minds the seeds of good feeling to ripen with profit to their future career, by inculcating the maxim, that sound principle is the only true guide to honour; and that nine-tenths of our success depends upon ourselves. On this account we hope that no young gentleman will hereafter enter public life without having read these volumes; especially, if he be intended for a place of constituted authority. In the case of parents having so great an objection to their sons imbibing a taste for the sea, as to withhold the History of Robinson Crusoe from their perusal, we would recommend them to keep back this book also, as we fear it might, like that bewitching history, derange their plans, by giving the young gentlemen a relish for salt water.

Capt. Hall's refutation of the hackneyed assertion, that *school days are the happiest time of life*, will find a ready welcome in the heart of every school-boy; for schoolboys are seldom so well satisfied with the indispensable discipline of this stage of life, as not to sigh for their emancipation; and pant with eager hope for that delightful period when their minds, as well as limbs, shall be free as air, and the world with all its pleasures be spread out before them. To the fallacy of this old-fashioned notion we can speak from experience, and we can add our testimony that Capt. Hall is not the only thoughtful school-boy who has exclaimed, "If it is certain that my future life is to be more wretched than this, which is now so full of misery, what, alas! is existence worth?" and who has found himself agreeably disappointed in after life. For the benefit of our pensive young friends, we shall quote our author's sentiments on this subject.

"In this terrified frame of mind, I dived into various other works, but, to my sorrow, very seldom met with any thing of a more consolatory nature. Nor was it till many years' trial of the wear and tear of actual life, that I came to learn the fallacy of most of these assertions respecting the comparative happiness of school; and to feel assured, that the whole, or nearly the whole matter, lies essentially with

* Fragments of Voyages and Travels, including Anecdotes of a Naval Life; chiefly for the use of young persons. By Capt. Basil Hall, R.N.

ourselves, since, in any situation in life, the amount of our happiness will be found to bear, in the long run, a pretty exact ratio to the heartiness with which we perform our duty."

Fully concurring in the truth of these observations, we shall only add, that the first step towards that hearty performance of duty which will produce the desired result, is to get clear of the undue care for, and estimation of self, which is too apt to be fostered by the fondness of friends at home, and to learn to feel what is due to those about us.

Our author thinks that a great advantage to discipline is derived from an officer's being disposed to look at the bright side of every thing. His views on this subject are well stated, and are illustrated by an anecdote of Lord Nelson, which is new to us, and which gives a good exposition of the distinctive characters of that officer and of Lord St. Vincent.

"This desire of discovering that things are right, accompanied by a sincere wish to express that approbation, are habits which, in almost every situation in life, have the best possible effects in practice. They are vastly more agreeable, certainly, to the superior himself, whether he be the colonel of a regiment, the captain of a ship, or the head of a house; for the mere act of approving seldom fails to put a man's thoughts into that pleasant train which predisposes him to be habitually pleased, and this frame of mind alone essentially helps the propagation of a similar cheerfulness amongst all those who are about him. It requires, indeed, but a very little experience of soldiers or sailors, children or servants, or any other kind of dependants, or even of companions and superiors, to show, that this good-humour, on the part of those whom we wish to influence, is the best possible coadjutor to our schemes of management, whatever these may be. The approving system is, also, beyond all others, the most stimulating and agreeable for the inferior to work under. Instead of depressing and humiliating him, it has a constant tendency to make him think well of himself, so long as he is usefully employed; and as soon as this point is gained, but seldom before, he will be in a right frame of mind to think well of others, and to look with hearty zeal to the execution of his duty. All the burthens of labour are then lightened by the conviction that they are well-directed; and, instead of his severest tasks being distasteful, they may often, under the cheering eye of a superior, who shows himself anxious to command what is right, become the most substantial pleasures of his life.

"I need scarcely dwell longer on this subject, by showing that another material advantage of the approving practice consists in the greater certainty and better quality of the work done by willing hands, compared to that which is crushed out of people by force. No man understood this distinction better than Lord Nelson, who acted upon it uniformly,—with what wonderful success, we all know. Some one was discussing this question with him one day, and pointing out the eminent success which had attended the opposite plan, followed by another great officer, Lord St. Vincent.

'Very true,' said Lord Nelson, 'but in cases where he used a hatchet, I took a penknife.'

The following observations nearly connected with the foregoing, are just and valuable.

"It will readily be understood by any one who has attended much to the subject of discipline, and will be felt, I should think, more or less, by all persons who have been engaged personally in the management of a house, a regiment, a ship, a shop, or any other establishment in which distinctions of rank and subdivisions of labour prevail, that nothing ever does, or can go on well, unless, over and above the mere legal authority possessed by the head, he shall carry with him a certain amount of the good-will and confidence of those under him.

In ordinary times, it is true, the duty goes on pretty well in a ship of war, by the sheer momentum of an established routine.

But in times of danger, when doubts and difficulties beset an officer, or protracted labours fatigue his crew, and untried resources and exertions are called for every

moment, it is discovered that mere routine, (though even at such periods it does a great deal,) will not accomplish all that is required. The captain then finds out, often when it is too late, that unless motives of a more generous and stirring nature come into play to give fresh vigour to the formalities of his discipline, not only his own reputation, but some of the great ends of the public service, may be lost."

These quotations are sufficient to justify our opinion of the moral tendency of the book, as being peculiarly applicable to the duties of persons in the higher walks of professional life. We now come to our author's opinions about promotion, which involve a slight dash of politics. Our agreement with him upon this subject is not quite so unqualified, as upon that of his morals or discipline. In the first place we renounce the idea of mere seniority being a criterion for promotion, which is either just or conducive to the public service. Next, we agree, with every body, that merit ought to be that criterion; but those who have this common-place observation frequently on their tongue, forget that the judges of this merit, in whatever way constituted, must be men; and that they cannot, therefore, be divested of human partiality. The question thus turns upon, what is the best method of controlling that power by which promotion is effected? We shall find this controlling power referred to among the following quotations.

"Generally speaking, I think it is observable in the service, that officers who are the most certain of getting on, are also among the most earnest in their endeavours to justify, as far as depends upon themselves, those acts of distinction by which they have been, or are still to be, put before older men, perhaps no less worthy of promotion."

We can only admit this with the limitation used in the preceding paragraph, namely, that of the party being "a right-minded person," and not as a general rule. We make this limitation, more especially, because those who were most sure of getting on heretofore, did not necessarily belong to families of high rank and liberal education; but were sometimes promoted over other men who added that distinction to their being older and better officers.

Again,

"The opinion will hardly be controverted, that persons who are the most gentlemanlike in their habits of thought, in sentiment, and in manners, supposing their talents and opportunities alike,—generally speaking, make the best officers."

This serves to introduce us to Capt. Hall's general views on these subjects.

"I believe it will be found, that it is this, amongst many other reasons, which renders it of so much consequence to the well-being of the navy, and to the maintenance of its high tone of feeling and action, the qualities upon which, in the end, nearly all its value to the country will be found to rest—that we should encourage men of family to enter the navy. It is not the mere possession of rank which gives efficacy to the services of such persons; since quite as good blood, for the ordinary purposes of daily business, might be found in profusion in the other walks of society. But what is indispensably required in the naval profession above all others,—if its present lofty station is to be preserved,—is not alone great mental powers, or zeal, or industry, or experience, or even all these combined, to any conceivable amount; but the essential spirit, if I may so term it, of a gentleman. This quality in the character of an officer, must, by some means or other, be made to predominate, and, as it were, to exalt all the others. Without this, the navy would be nothing—or worse than nothing—it would, certainly, become ruinous and disgraceful to the country.

"In other professions having any claims to what is called liberality of object, the same spirit is, undoubtedly, more or less required; but in the navy it may well be said to be all in all. It would, perhaps, occupy too much space at present, to

say why this is necessarily the case; but one of the reasons seems to be, that many of the important duties of a naval officer are, and ever must be, performed without witnesses, and often beyond the reach of scrutiny."

And again,

"One of the duties of the aristocracy, and by no means their least important function, is to keep alive this sacred fire, this quality (gentlemanly spirit,) by which, after all, 'Earthly power doth show likest God's.' It is they, and they alone, who can give a right tone to manners, by setting the fashion in every thing which is true in principle, or practically wise in morals and in politics, and by encouraging science, letters, and the fine arts, or otherwise contributing to soften the asperities of vulgar life. This is the true intent and purpose of a powerful aristocracy, and if its obligations be duly fulfilled, its members execute a task not only of the highest possible utility to the country, but one which, for many reasons, no other class has the means even of attempting to perform.

"Let the scoffers at high rank and unequal wealth say what they please, there can be no doubt, that since these are the obligations which time has fixed, no matter how or when, upon the aristocracy of this country; so, in the main, the persons who compose that order, actually perform, and, indeed, must always continue to perform their duty, as long as the merciless searchings of our inquisitorial press, goaded on by the vigilance and insatiable curiosity of public opinion, shall place all its members, all their property, and all their proceedings in the fullest possible review before the world."

Here we have the controlling power which preserves, and which, we hope, may long preserve to us the valuable services of a high-minded aristocracy. We know what human nature is, and therefore know into what its privileged orders would relapse, if the watchful scrutiny of an intelligent, and we may add, a high-minded public, were withdrawn.

The same consideration of what human nature is, teaches us most fully to agree with Capt. Hall in estimating the value of an aristocracy thus prominently and honourably placed in a situation in which they are made to feel themselves called upon to stand forward as an example to their fellow-men. On this consideration we hail with pleasure the prospect of their being emancipated from the odium attached to the abuse of a power which could not constitutionally be called their own. In applying these opinions on the advantageous influence which a well-principled and public-spirited aristocracy has upon society, to their use in the navy, Capt. Hall proceeds:

"Precisely what the aristocracy does on the great scale for the community at large, in maintaining at a high level the pure standard of national manners; the introduction of a proportionate number of persons of good family into the navy, does for that service in particular."

With these opinions we feel generally disposed to concur, on the ground of the inferred benefit to the service at large, not with the abstract view of favouring a particular class; and upon the proviso that positive injustice to *any* party be not the price of favour to another. The British Navy will continue, we trust, as heretofore, to produce from its subordinate stations, men without other pretensions than the will and the capacity to achieve the highest posts and dignities; while it will still recognize, with no less pride, those aspirants for its honours, who ennoble hereditary rank by personal and professional deserts. At what follows we may be allowed, as old officers, to indulge a growl.

"But I have heard it said, why not put matters in this respect upon a fair and equitable footing? If this sprinkling of the aristocracy do good, as you say it does, to the spirit of the navy, why not let men of family enter the field on equal terms with the rest, and so take their chance with men of humble birth? The simplest answer to this appears to be, that as there is no method by which such persons can be impressed into the service, we must of necessity enter into some tacit kind of

compromise, and agree to take them on the best terms for which we can enlist them as volunteers."

To this we answer, that if such compromise be necessary, it is a necessary evil: the necessity, however, seems to be clearly made out; and we must say, that we would not forego the advantage of having the aristocracy of the land among us, to get clear of the evil; and, what is of more consequence than the feeling of growling old officers like ourselves, we believe that the country would lose by having recourse to such an alternative.

But, according to our recollection, officers were generally very liberal in regard to the promotion of their juniors who belonged to families of high rank. The truly sore subject was, the promotion of men of low and vulgar habits; sometimes, moreover, incapable of performing the duties of the station they had already attained. We can remember more than one instance of such persons even boasting of the borough interest by which they had received, or were about to receive their promotion. We have no disposition to grumble against former administrations; the wonder is, how they found means to promote so many officers who had no borough interest, hampered as they were by that overweening power, the undue and obnoxious exercise of which is, we trust, about to receive an effectual check, without a still more mischievous violation of the spirit and forms of the established constitution. So much for politics and promotion.

We now turn to the more agreeable task of considering the amusement to be derived from this book.

To us it brings back the days of our youth in all their freshness; and we cannot resist the feeling of being ourselves one of the mischievous party who stuck the tail of the tailor to the cable tier with handfuls of pitch, or tore their black handkerchiefs in pieces to put the Lieutenants' dogs in mourning for our poor friend "Shakings!"

If our partiality for those days does not blind us, we think that the scenes in these volumes cannot fail to absorb the mind of every reader, although unacquainted with the localities referred to. This seems to arise from that power of true painting, that faculty which we admire so much in Sir Walter Scott, by which our author brings before us the actors in those scenes, with all the force of real presence. We suspect that not a few of Capt. Hall's fair readers have laughed over the pranks of his midshipmen, and grieved when they reflected that "by far the greater number of these promising young men have found graves, some on land, some in the deep sea."

The same powers of description place before us, with wonderful truth, the characteristic invasion, by the French, of Corcubion—a Galician village lying in a secluded nook within the great Bay of Finisterre. Of this remote spot, in connection with the Peninsular contest, few of us have ever heard before; yet has the author constructed upon the scenes he witnessed there in the *Endymion*, an episode awakening powerful interest, and produced a stirring and faithful epitome of the general war on the Peninsula.

With equal fidelity, spirit, and, we may even add, originality, Capt. Hall traces his recollections of the battle of Corunna, at which he contrived to be present as a shoregoing interloper. This description, we have heard from an officer who was present and recollects to have noticed the Amateur Blue Jackets, conveys a striking impression of the general scene, and is peculiarly calculated to revive in the memories of its surviving actors, touching associations of its glory and its gloom.

Notwithstanding the superabundant details we already possess of this battle, we follow Capt. Hall with no common interest in his ramble among "the sleeping soldiers, piled muskets, and camp equipage," and readily recall to our minds similar instances of the heartless and spirit-worn appearance of the men while the enemy remained still, and the quick return to life and animation when his movement gave promise of a battle; "I saw these

men spring from the ground as if touched by a magic wand, all full of life and vigour."

In the details of the loss of His Majesty's ship *Atalante*, off the harbour of Halifax in Nov. 1813, an admirable lesson of discipline and the force of example is judiciously presented to the junior ranks of the service. The conduct of the commander, Capt. Frederick Hickey, like that of Sir Murray Maxwell under similar circumstances, does honour to the man, and exalts the character of his profession.

The adventure off "Rockall" is made the most of, and is expertly interposed between familiar professional details, which it pleasantly relieves. We observe that this chequering of his subjects is practised by the writer throughout these volumes, with much tact and effect. Thus, for instance, he winds up his desultory labours with a most animated sketch of the chase and capture of a French privateer by the *Endymion*, from which we can only afford the following extracts.

"By this time, of course, every man and boy in the ship was on deck, whether it was his watch or not, even the marine officer, the purser, and the doctor, left their beds—a rare phenomenon! Every one was giving his opinion to his neighbour; some said the shot went over her, some that they fell short, and the opinion that she was a witch, or the flying Dutchman, or some other phantom, was current amongst the sailors. Whilst the marines were clinking their flints, and preparing to give our little gentlemen a taste of the small arms, when within their reach. While things were in this anxious, but very pleasurable state, our foresail flapped slowly against the mast; a sure indication that the breeze was lulling. The quadruple rows of reef-points were next heard to rattle along the topsails, sounds too well known to every ear as symptoms of an approaching calm.

"Not a mortal on board the frigate ever expected to see the poor brig again. What, then, was our surprise, when the smoke blew swiftly past, to see the little cocky gliding away more merrily than before! As far as good discipline would allow, there was a general murmur of applause at the Frenchman's gallantry. In the next instant, however, this sound was converted into hearty laughter over the frigate's decks, when, in answer to our thundering broadside, a single gun, a six-pounder, was fired from the brig's stern, as if in contempt of his formidable antagonist's prowess."

We lament that our limits will not permit us to give the whole of this spirit-stirring chase; but we must leave room to give one more specimen of the generous and gentlemanly feeling which pervades the writings of Capt. Basil Hall;—he is describing another chase.

"During the chase, indeed, while our masts are bending over the sides, and we can scarcely walk the decks under the press of canvass: while we are banging off the bow-chaser guns at the flying enemy, at whose gaff-end we can see the golden flag of Spain, yellow, red, yellow, with a flaming crown in the centre, fluttering before us, and telling a tale of bullion in huge bars, or cochineal in bales, our whole thoughts and feelings are absorbed in the pursuit, and in the erection of castles in the air, out of the proceeds of the treasure close a-head, and all but grasped. By and by, the well-aimed six-pounder, fired from the fore-castle, cuts away the peak-halyards of the chase, and down comes his mainsail. In the next minute we are alongside of our prey.

The prize is hailed, with a query—'Where are you from?' 'La Vera Cruz.' This answer produces a loud expression of pleasure along the decks; but is instantly hushed to have the reply of the next question—'What is your cargo?' 'Plata senior.' Which is echoed by a hundred voices; and it is not saying too much to suppose that the pleasure of that moment far exceeds any that attends the subsequent distribution, or even spending of the money.

"The boat is soon lowered down, and the Spanish captain, with his papers, brought on board; upon which we learn that the ship and cargo are chiefly the property of an old Spanish merchant, who with his wife and family, are in the

vessel, on their return to Cadiz, after twenty long years of honest industry in the colonies. The next boat brings the white-headed old gentleman and the ladies on board, calm and dignified under their calamity, according to the noble spirit of their country, although totally and irretrievably ruined.

“ It might savour of affectation to declare, that I have seldom paid away a dollar of prize-money got in this way, without its summoning up the image of some of these wretched groups of captives, whose grief forms such a deep contrast to the joyous expression of the light-hearted winners.”

The views of Capt. Hall as regards the management, habits, and comforts of honest Jack are practical and benevolent. They may be read with advantage by his younger brother officers. We shall close our remarks by observing that the spirit of self-devotion to the public good, and consideration for others while performing our own duties, which we find inculcated in these volumes, are as applicable to the military as to the naval service, and as likely to be serviceable in a barrack as in a cock-pit.

Since the foregoing went to press, we find that the honorary degree of Doctor of Laws has been publicly conferred on Capt. Hall, by the University of Oxford. This distinction, as in the late instance of Sir Howard Douglas, may fairly, we think, be viewed and appreciated as a compliment to the United Service, thus honoured in the person of one of its eminent members. It shows that the bay on the brow of a sailor or soldier may imply a double trophy, denoting him alike distinguished *tam Marte quam Mercurio*.

When the late Capt. Foster (then a Lieutenant) received the Copley Medal from the Royal Society, that lamented officer went straight to the Admiralty, and mentioned the fact to their Lordships in the following terms, “ Here is the symbol of the highest honour the Royal Society can bestow: it has been given to me for works I have done in his Majesty’s Service—and I cannot but feel that the compliment is paid to the Navy at large:—I have merely been their instrument.” There was truth and elevation in the sentiment.

* * * The length of the foregoing Reviews compel us to defer the continuation of our Critical Notices for the present month.

QUERIES.

1. Should not the towers built for defence upon sea coasts be termed *Metella* towers, and not, as generally written, *Martella*, and *Martello*?
2. Which is the proper word—*shoal*—*school*—*scole*—or *shole*, as applied to a collection of fishes in the ocean, and differently written?
3. Which is the proper word for a mountain which ejects fire, &c. *Volcano* as is generally written, or *Vulcano*?
4. *Jetty*—*jettie*—or *jutty*—of those three words, which is the most proper?
5. The proper name, “ Tom Collins,” is of frequent use among the Mids and the sailors in a man-of-war. Who was this said Tom Collins?
6. What could have given rise among seamen to the strange idea of calling the ocean “ David Jones’s locker?” Who was this said David Jones?

The name is evidently Welsh; I may just add that from our Cam-

brian brethren not having any direct trade to the West India Isles, the Negroes were puzzled to class them among nations; these sable gentry remarked that Englishmen, Frenchmen, Spaniards, &c. &c. "hab ship, all hab ship but Welchman, he no hab ship—Khi! warra sort of somebody dis Welchman?—Cho! he mus lib in bush like Neger!

7. Tell that to the Marines." Whence this saying, and what is its import?

8. Why is the term "*messenger*" applied to the small cable used in heaving up the anchor? Would not "*aider*" have been more appropriate?

9. The origin of the expression among seamen, for transitory airs of wind—" *Cat's-paw*?"

10. The Anglo-Americans of the United States in their journals generally write, "*reeved*" the topsails, for "*reefed*" the topsails: Which is correct? and, would not "*refit*" the topsails, be more appropriate than either?

11. What gave rise to the term "*Cat-head*" being applied to the timber-piece employed in lifting the anchor to the bulwark; Was it originally given arbitrarily by some shipwright, who thought proper to ornament the butt with the representation of a cat's head?

12. What is meant by the (inelegant) expression used in old voyages, (such as James's Voyage of Discovery, 1631,) of "*stinking fog*?" Is the odour of any fog offensive to the olfactory nerves?

13. Spar-deck. Whence this term applied to a deck loosely *planked* with fir, bamboo, split, &c.? a *spar*, according to the genial acceptation of the term, being a *solid stick*, a tree shorn of its limbs, either rough, or otherwise shaped for use.

14. The origin of the term *caboose*, or *cubhouse*, in use for the portable kitchen on board merchant-vessels—is it a corruption of "*Cook's-house*?"

15. Why is the term "*companion*" used to the screen and covering at the cabin hatchway, in merchant-vessels?

16. Is not the space in frigate-built ships called the "*steerage*," misnamed?—as is also the "*gun-room*?" Why were these originally so named?

17. Which is the proper orthography—*grapnel*—*graplin*—or *grappling*? (a small anchor.)

18. The term "*sheet*" anchor, applied to the *reserve* anchor—why so called?

19. Gudgeon, or *googing*, the metal eye of the rudder—are either of these words correct? if not, what word is?

20. Imprest; the origin of this term used by our "*afectonate* friends," when a charge is made upon the wages or pay of a naval officer?

21. Kelson—Keelstone—are either of these the proper orthography for the upper part of a ship's keel? and whence the term "*keel*?"

QUÆRO.

GENERAL CORRESPONDENCE.

TO THE EDITOR OF THE UNITED SERVICE JOURNAL.

Yeomanry Cavalry.

MR. EDITOR,—In the observations which I took the liberty of addressing to you, and which appeared in your admirable Journal of May last, I regret that some expressions have given offence to one at least of your readers, who signs himself "A Cavalry Captain." I separated the subject under consideration into two parts; the one relating to the regular service, all interference with which I explicitly disclaimed; the other relating to yeomanry, to which alone I adverted: whether his remarks or mine most merit the character of "unmeaning criticisms," and "sneering comments," I leave others to decide.

The "Cavalry Captain" has mingled these two subjects together, for the purpose, as it would seem, of representing me as pronouncing a judgment upon matters of which I was an incompetent judge, and thereby exciting the *esprit de corps* of his brother regulars against a luckless wight of a yeoman, who should presume to hazard an opinion upon the sublime mysteries of "threes about," and "left shoulders forward." He has also, though I trust unintentionally, quoted my words as asserting that which I only put hypothetically. But now to the charges of this "Cavalry Captain."

The lines behind which I stand entrenched are—1st, That when yeomanry officers are placed in line with their backs to their men, any irregularities which arise must be corrected by the non-commissioned officers on their flanks, or not be corrected at all. 2nd, That in the yeomanry, non-commissioned officers are not so competent to correct such irregularities as the commissioned officers. 3rd, That the usual unsteadiness of the horses of yeomanry officers renders them unable to move with that accuracy which is indispensable to enable the men behind them to preserve an unbroken line.

The "Cavalry Captain" observes upon the first, "Does he then forget, or is he altogether ignorant of the fact, that whether troop officers are in front or on the flank, still according to all regulations, whether old or revised, the dressing of the squadron when ordered to advance has invariably been to its centre; and for an officer upon the flank of a squadron to call to the men to *dress toward him, or by his direction*, would be a flagrant violation of the principles of Dundas, who so frequently urges the necessity of all dressing proceeding from that point to which the eyes of the men are turned, and which in this case is of course the centre." Now, Sir, to adopt the courteous language of the "Cavalry Captain," you will perceive at once how "frivolous and ill-founded are the objections of our critic," by remarking that he confounds, or does not understand the difference between a direction, order, or caution, given to his men by an officer on their flank, and ordering them to *turn their eyes toward him*; he seems to think it impossible that an officer on a flank should be able to say "eyes centre," as easily as "eyes right." The essential difference consists not in the words he has to say, but in his being able to see when to say them. This he can do when he is on the flank; and this he cannot do when his back is turned towards his men.

The "Cavalry Captain" next says, "To dress the squadron *from its two flanks* at the same time, on the supposition that the squadron officer cannot see anything of his men, because his back is turned towards them, would have the effect of making him a complete cipher; and frequently of actually disjoining the squadron in its very centre, where of all places it ought to be most solid and compact." I said nothing about "dressing from two flanks at the same time;" but I assert an uncontrovertible fact, that for the purpose of correcting irregularities as they arise on the march, the commander, by having his back to his men, is "a complete cipher;" and of this ciphering I complain.

The "Cavalry Captain" endeavours to fix a charge of inconsistency upon the statement that the unsteadiness of the horses of yeomanry officers makes them less fit than those of the regular cavalry for being placed singly in front of the line, while at the same time I recommend, that agreeably to the regulations of Dundas, "the officers should be placed on the flanks, where steadiness and correctness are of such exceeding importance." Is it possible that "the experience of an old troop officer" should not have shown him that horses are generally more quiet in line, and abreast of other horses, than when sent out singly by themselves? But even let that be granted, which is contrary to fact, namely, that a horse unsteady in front of a line, would be equally unsteady abreast of a line; in the one case his unsteadiness disorders the whole squadron which is to follow him; and in the other case the unsteadiness of his horse does not in the least affect it.

The "Cavalry Captain" assures us, that some regiments of yeomanry do "go through a routine of complicated manœuvres on a field-day performed in pedantic mimicry of regular cavalry," who yet, when "marching home in high spirits at the encomiums of the reviewing officer, are grievously puzzled, officers and all, by having to pass an overturned waggon, where diminishing their front, and again increasing it after the obstacle was passed, would have obviated all the difficulty." I am as much opposed to the mimicry of the regular cavalry, and the fooleries of reviews, as the "Cavalry Captain;" and I am extremely surprised at hearing it stated on such authority, that a regiment can "go through complicated manœuvres," and yet be unable "to diminish and increase its front." It would seem as if the "Cavalry Captain" was ignorant of the fact, that all manœuvres whatever are nothing but increasing, diminishing, or altering the line of front. It is, no doubt, very presumptuous in a "yeoman critic" to give this lesson in tactics to an "old troop officer," but I, nevertheless, venture to assure him, that he has been doing nothing all his life of cornetcy, lieutenantcy, and captaincy, but extending and diminishing his front, or giving it a new direction; and this preparatory only to an advance, or a retreat. Perhaps, like the lady who on discovering that there were only two kinds of language, poetry and prose, found out that she had been speaking prose all her life without knowing it, the "Cavalry Captain" may only just have learned that forming column, is diminishing a front; and forming line, extending it.

The "Cavalry Captain" is pleased to give us a specimen of his wit, as well as of his powers of argument, by a "right merry and conceited description" of a field-day on which the captains of troops of yeomanry were unable to wheel their squadrons into line, from not knowing their markers. But the wit and the argument are alike misplaced, from the "Cavalry Captain" having failed to show the only point in discussion, namely, how these captains, who could not properly lead their squadrons when placed on the flanks, would have been better able to lead them when placed in front. If he finds any great source of mirth in seeing men spend time and labour to no purpose, he may rest assured that he will be much more gratified under the new regulations than under the old.

Leaving all farther general arguments, I will now state a few facts which have occurred since the date of my last communication to you. A troop of yeomanry has been lately raised in one of the districts that was harassed by mobs last winter. None of the officers had ever served before, and were selected for commissions, as is usual in such cases, on account of their property and influence. A captain of hussars who was badly wounded in the Peninsula, and has been ever since on half-pay, and a major of cavalry, who served to the end of the war, both of whom reside in the neighbourhood, kindly undertook to drill the troop. The officers fell in with the men; were placed on the flanks of divisions; and no yeomanry could perform better. As soon as the regiment was completed, and an adjutant fresh from the line appointed, the task of drilling devolved upon him; this he did according to the new system; and the officers were placed in front of the line.

I was lately present at one of their drills; the two officers who had previously drilled them, were on the ground also; no men could perform worse, to the great mortification of those who had previously witnessed their correctness.

The commanding officer of one of the largest yeomanry regiments that has yet been raised, and himself formerly in the hussars, and therefore prejudiced in favour of the method there adopted, has recently issued orders for the regiment to be drilled according to the instructions of Dundas.

The adjutant of a regiment of yeomanry who has just left the line, and who is very anxious to adopt the new method, acknowledged to me, that it will be impossible, unless he can get the horses of the officers as steady as those of the line.

This brings me to the really insurmountable part of the difficulty. There is no portion of the duties of cavalry, in which so great improvement has taken place in late years as the horsemanship; but whoever thinks that it will be possible for the yeomanry to approach in the smallest degree to the regulars in this department, knows nothing of scientific equitation himself, nor of the description of horses on which yeomen are mounted. If one of the regiments of Life Guards was mounted upon horses fresh from the yeomanry, can any cavalry officer be so ignorant as to suppose that that regiment could perform as it now does on field-days? Nay, farther; let the men be mounted upon 300 of the best hunters in Leicestershire, the result would be the same. It is notorious, that using the term *riding* in its scientific sense, there is no nation in Europe that *rides* so ill as the English; have their horses so badly set up; and so little in hand and at ready command. The difficulty of yeomanry in this respect is much increased by the absurd practice of having a pattern bit; a practice quite indefensible, unless a pattern mouth could be procured also. The evil effect of this is not felt so much in the regular cavalry, because the horses are always rode in the same bit, and may be habituated to it in time; but the yeomanry horses are never rode in it except on the days when they are out on duty, and when the horses are, especially, unquiet owing to the noise, glitter, and irritation of the accoutrements.

The necessary consequence of all this is, that yeomanry, not having their horses properly in command, will never preserve their line so perfectly as a regiment of the line; and I maintain, that an officer is in a better situation to correct irregularities as they arise in a place where he can see them, than in a place where he cannot. I am old enough to remember the time, although the "Cavalry Captain" may not be, when regiments were drilled according to the fancies of their several colonels. The Duke of York obliged them all to adopt the same system. The best parts of all their fancies were received after accurate consideration. Sir David Dundas took up nothing from caprice or idle imitation; his regulations were the result of experience, and grounded upon scientific principles: that the farther we depart from them is for the worse, and the closer we adhere to them is the better, is the increased conviction of,

Sir, your obedient servant,
A FIELD OFFICER OF YEOMANRY.

The reputation of the Turkish cavalry was entirely owing to their horsemanship, and not to their superior use of the sword. In the lines before Ishmael, the young Russian officers were very fond of going out in small parties, or singly, to challenge the Turks. Wherever the Russians were single, they were invariably killed by the Turk, who always contrived to gain the left flank of his adversary, and which we know a horseman cannot defend; while on the other hand, when there were four or five Russians who would keep together in one unbroken band, they were the victors.

The Twenty-third Light Dragoons at Talavera.

MR. EDITOR,—You are right in saying that Colonel Napier “has given short measure of praise to the 23rd Dragoons for their conduct at Talavera.” Victor Duke de Belluno was not so parsimonious of his praise, when he sent his aide-de-camp to the officers of the 23rd who were taken prisoners, and “told them that he wished to see the men that made so daring and successful a charge,” and after several compliments on their gallantry, sent his aide-de-camp to conduct them into good quarters at Castel Legos, with an intimation, that if they would write a letter to Sir A. Wellesley, requesting to be exchanged, it should be forwarded by a flag of truce: which was done. Gen. Villatte was equally complimentary, and so were a great portion of the French general officers, who came to see what sort of people the 23rd could be, who would dare to burst through the invincible column: they thought it must be the effects of *aguardente*. Victor’s Aide-de-camp (Capt. O. G.—m) told one of the 23rd officers, while conducting him to Castel Legos, that the General was never so much astonished as at the daring and desperate charge made by the 23rd; in fact, that the fighting on that day exceeded any thing he had ever seen before; that the English fought more like lions than men, and that their conduct throughout was above all praise, but that of the 23rd was never equalled. During the three days that the officers were at Castel Legos as prisoners of war, with a very slender guard, indeed almost nominal, they were treated by Gen. Villatte with the *utmost kindness*. He sent dinner to them from his own table, with abundance of wine. His Aide-de-camp and brother-in-law, Capt. Cholet, visited them twice each day, to see they wanted for nothing, and two and sometimes three surgeons visited them (by order) twice a day to dress their wounds; in fine, the greatest possible kindness and attention was shown to them, and when their escape on the night of the 31st of August was easily effected, if not connived at, as the French retired without insisting on the officers being taken away, although carts had been provided, they pleaded the badness of their wounds, which was taken as excuse sufficient to be left behind. A great portion of what is above stated can be vouched for by the three senior officers of the 23rd, who are still happily alive, and it would not, and could not, be denied by Victor, Villatte, and many other generals of the French army and their staff who are still alive, and are certainly more ready to admit merit in the English army than the English are themselves. The writer could furnish many anecdotes connected with the transaction, that would convince Gen. Victor and his staff that he knows all about it.

Any use you may choose to make of the above is at your service, and to put it into any form you may please; but never let it be denied that the 23rd charged *through* the French column—that still can be proved *beyond all doubt*.

AN OLD TALAVERA MAN.

Yacht Clubs and Regattas.

MR. EDITOR,—The writer of an article headed “Yacht Clubs and Regattas,” which appeared in the May Number of your excellent *Journal*, in enumerating those regattas which are, as he asserts, conducted “on a liberal and extensive scale,” altogether omits that of Cork Harbour, and would, I presume, lead your readers to believe that the regatta at Cove is conducted on less liberal principles, or is less extensive than those of Cowes, Dublin, Belfast, and Plymouth, which are honoured by his notice. This indirect reproach upon the oldest Yacht Club in the United Kingdom,* and upon a

* The Cork Yacht Club is of great antiquity, and there are no records extant to show the exact period of its foundation. We are in possession of a book containing the rules of the original establishment, called “The Cork Harbour Water Club,” which was printed in 1720; but the Club was no doubt founded previous to that period.

regatta, which, to say the least, is not inferior to any of those that have been enumerated, is so unjust, that I trust you will give a place in your pages to the following short statement of the principles upon which the Cork Harbour Regatta has been hitherto conducted, and of the prizes which have been offered by the club for the last two seasons.

I must first premise, that unlike the exclusive regatta at Cowes, where yachts belonging to the Royal Yacht Club only can contend for the prizes, (this was also the case at Portsmouth and Plymouth until last season,) the Cork Harbour regatta has always been open to gentlemen's yachts from any part of the United Kingdom. That no military precision is exercised with regard to the time of entrance or starting; so that a visitor, delayed by accidents or contrary winds until the day before the race, has no apprehension of being told that he is "too late to enter;" nor are yachts obliged to start until the stewards satisfy themselves that they are all equally well prepared. Our Club-house also is open to the members of the Royal and Northern Yacht Clubs during their sojourn in our harbour. So much for the liberality of principle on which the Cork Harbour Regattas are conducted; I shall now proceed to show their extent.

The prizes for the Season 1829, were

For Yachts not exceeding 100 tons	£60	
Ditto 45 ditto	40	
Ditto 30 ditto	30	
Ditto 20 ditto	20	
Ditto 15 ditto	15	
Ditto 10 ditto	10	
	—	£175
Hookers, or Fishing Boats not exceeding 30 tons	41	
Ditto 15 ditto	24	
Ditto 10 ditto	11	
	—	76
Whale Boats, 1st Class	17	
Ditto 2nd Class	17	
Six-oared Boats	10	
Ladies' Cup for Row Boats	20	
Gentlemen's ditto	20	
	—	84
		<u>£335</u>

Season 1830.

For Yachts exceeding 45 tons	£50	
Ditto not exceeding ditto	40	
Ditto 30 ditto	45	
Ditto 20 ditto	30	
Ditto 10 ditto	10	
	—	£175
Hookers, or Fishing Boats not exceeding 30 tons	35	
Ditto 15 ditto	20	
Ditto 10 ditto	11	
	—	66
Whale Boats, 1st Class	15	
Ditto 2nd Class	11	
Ditto 3rd Class	11	
Six-oared Boats	10	
Ladies' Cup	25	
	—	72
		<u>£313</u>

Trusting, Sir, that I shall be considered to have shown that in the list of

those regattas which are conducted "on a liberal and extensive scale," the Cork Harbour Regatta may fairly claim a place,

I remain, your constant reader,

A MEMBER OF THE ROYAL CORK YACHT CLUB.

Cove, June 1st, 1831.

United Service School—Naval and Military Museum.

MR. EDITOR,—I have read with interest in your Journal for the present month, the report of a meeting, at the Thatched House Tavern, St. James's-street, preliminary to the establishment of a school for the education of the sons of Naval and Marine officers. It has occurred to me, that the benefits proposed in the formation of this school, the chief of which appear to be, to provide a respectable general education at a moderate expenditure, and to ensure to the pupil a society more select than would result from the union of boys in a school, open to all, where the premium is fixed at a low rate, may be extended to the sons of officers of the *regular army*,* and that with increased advantage to the institution itself, and to the country generally. As it is proposed to combine nautical instruction with the ordinary education of young people of the more respectable classes, it may be observed, that such elementary knowledge is equally adapted to prepare a youth for the army. Mathematics is the foundation of the peculiar studies of each profession, and languages, fortification, and artillery, are equally useful to one and to the other. The jealousies which once existed between the naval and military service are no longer known. The United Service have long felt that the glory and honour of each branch is reciprocally reflected on the other. The United Service Clubs, and your own periodical, Mr. Editor, have in no small degree contributed to foster this desirable feeling. The Naval and Military Colleges, too, are based on the principle, that the sons of officers of either service shall be admitted with equal advantage to one establishment or the other. If, then, the Crown has set an example of cultivating this union of interests between the services, is it not to be regretted that the principle should be deviated from in the formation of any institution which promises to be of national importance? If it were desirable to create an exclusive and illiberal feeling in the young men to be educated at the proposed institution, no surer method could be adopted than that now proposed; but, Sir, if instead of being a Royal Naval School, it were an UNITED SERVICE SCHOOL, it would tend to strengthen and perpetuate that cordiality of feeling between the Services, which is not only calculated to promote the individual happiness of officers of both Navy and Army, but is essential to the best interests of our country, and not unfrequently to the success of great national undertakings.

Your Journal of this month, Mr. Editor, announces the establishment of a Naval and Military Museum, an institution worthy of the utmost commendation and support, and not the less so for being another *United Service Society*. Its extreme liberality is, perhaps, liable to objection, admission being extended to bodies of men not identified with the profession of arms; it might be sufficiently comprehensive, if in addition to the officers of the Navy, Marines, and regular Army, it included all Company officers, their attachés, and the commandants or, at furthest, the field-officers of Militia and Yeomanry. In an *United Service School*, it could not be imagined that any could be admitted but the sons of officers of the Navy, Marines, and *regular Army*. The extension of number in a well-regulated establishment, the funds being proportionate to its increase, would, so far from lessening its advantages, augment them; much might be said in favour of this position, but, Mr. Editor, to your advocacy it is committed, no man being more

* In our notice of the proposed Naval School, we recommended, and again strongly urge, that the Army should participate in its plan and benefits.—ED.

competent or better fitted to vindicate the cause of the *United Service* than you, whose labours are so consistently devoted to promote that union which is the life of both services; and it is conceived, the merits of the present question being apparent and its object important, you will not fail to lend to it your powerful and influential aid.

I have the honour to be,

Mr. Editor,

Your very devoted humble servant,
Σ.

June 8th, 1831.

Masters in the Navy.

MR. EDITOR,—It is very much feared that the rising generation of Masters, that is to say, those who have been brought up entirely in the navy, will not prove so good as the old stock who were grounded in the merchant service, in consequence, it is said, of their not having sufficient practical knowledge as Channel pilots. I have, therefore, to make a proposition, which, if found worthy a place in your Journal, may by that means meet the eye of some of the naval men connected with the Admiralty, viz. as the coast blockade is going to be done away, and as several cutters have lately been paid off, I have to suggest that eight or ten cutters should be employed in the Channel to prevent smuggling, &c. each of these cutters to be commanded by a master, and to be allowed four or five officers, either second-masters, master-assistants, or volunteers of the second class, and by that means these young men will have an opportunity of obtaining that practical knowledge of pilotage which is so necessary for a master.

I am, Sir,

YOUR CONSTANT READER AND SUBSCRIBER.

Mates in the Navy without Rank.

MR. EDITOR,—Your pages being always open to any suggestions for the improvement of either service, I trust you will give insertion to the following comparisons between Ensigns in the Army and Mates in the Royal Navy. It is well known to all acquainted with Naval affairs, that a Mate has no rank whatever, although he must have served six years before he can pass his examination, and very frequently has served ten, eleven, and twelve years after he has passed, which qualifies him for the rank of Lieutenant, (equal to that of a Captain in the Army); whereas an Ensign enters the Army frequently at the age of sixteen or seventeen, which is at least two years younger than a Midshipman can pass, and has rank at once without a day's service. Surely that difference might be altered, (very much to the benefit of the service, as tending to render it more respectable, and certainly very much to the satisfaction of the officers concerned for the same reason,) by giving Midshipmen rank corresponding to that of Ensigns or Lieutenants in the Army, and a commission as soon as they have passed. Again, an Ensign, should he by any chance be placed out of employment the very day after he receives his first commission, has a right to half-pay; whereas a Mate, let him even have served twenty years as such on the most arduous duties, the moment he gets out of employment, (which he necessarily does much oftener than an Ensign, by ships in time of peace being paid off every three years,) does not receive one farthing of half-pay, and if he has (as is often the case) nothing but the service to depend upon, must either become dependent on his friends, or have recourse to manual labour for his bare subsistence. Is this a fit state for an officer to be reduced to who has served his Country faithfully, and in many instances fought her battles? Surely in these times of reform and improvement, these points should not be overlooked, but something should be done for a class of officers who have been long

looked down upon with contempt even by their superiors in the same ship, from their having no rank, and borne down by poverty and distress on shore, from having no resource from the moment they are paid off, should they (as it is too often the case) be unable to get another ship.

Hoping these remarks will meet the eyes of those honourable and gallant officers now at the head of the Admiralty, and lead to improvement,

I remain, Sir,

Your obedient humble servant,

A MATE.

Medical Department.

MR. EDITOR,—The Army in general, and in an especial manner the Medical Department, owe you many obligations for opening your Journal to an exposure of the abuses which have existed, and continue to exist in that department,—abuses which have arisen from a system of partiality and maladministration, that has produced distress and dissatisfaction little known to the public.* To have been a meritorious officer in the department, without at the same time having the power of gratifying the hobbies, and adding to the *éclat* and personal advantage of its chiefs,† has been to some a misfortune and source of disappointment as far as professional views in the service are concerned, whilst others have had favours lavished on them in a manner unprecedented in the bestowing of public rewards.

As specimens of the manner in which the department is conducted, it is only necessary to adduce some of the promotions of 1829, and particularly the extensive one of July 1830, which was understood to have been originally intended to include all those who had been actively and conspicuously employed during the arduous and trying duties of the late war, and who had been removed from permanent to unattached appointments. But mark how it was given: in some instances to men who had declined unattached appointments, although held out as a *sine qua non* to further promotion, and preferred the comparative ease and permanent comforts of a regiment, and even to some of these, as if born and reared only for indulgence, was given a retirement greater than they had ever received as a full, efficient, and working pay. We shall say nothing of the ingratitude of one person in authority concerned in the recommendations, for whom the staff surgeons of the period alluded to did so much, and for whom he has done so little; but we shall say in some cases it was a most uncalled for promotion, and an unjustifiable expenditure of public money.

We trust, however, that a reform in the department is at no great distance, but in the mean time it is necessary the medical officers of the army should continue to make known the grievances they have so long laboured under. To M. M. in your last Number, the service is indebted for his judicious observations on the stations of the medical staff at home, and more especially for those in Ireland, which, as examples of gross injustice to the regular medical staff, are without parallel. We wish him success in his future investigations, and hope that they may be a stimulus to others to assist in exposing abuses which have excited so much complaint.

London, 13th June 1831.

M. S.

* Under the present system of management, so overloaded has the department become in all branches, that measures have been resorted to for its reduction which have been very severely felt by many, namely, the calling back into active service men who had been forced upon half-pay, and left for many years as practitioners in civil life, or compelling these men to receive a commutation in money at a very disadvantageous rate to the individual.

† Every medical officer knows that allusion is here made to the funds and subscriptions for widows and orphans, and museums and libraries (at Aberdeen even), and pieces of plate and portraits, and to addresses and agencies, &c. &c. &c.

Army Medical Department.

MR. EDITOR.—The discussions on the subject of the Army Medical Department in your excellent Journal, I opine, have been productive of no inconsiderable benefit; the late regulations appear to engross many of the points there referred to, but still there are omissions, and room for amendments, a temperate allusion to which in your pages may be attended with beneficial effects.

In the new warrant for regulating the grant of unattached pay, retired full pay and half-pay, the allowance to the medical officer placed upon half-pay is regulated by two different schedules; the first, if placed on half-pay by reduction of establishment, and the second, if placed on half-pay from any other cause. The distinction bears on its face every appearance of plausibility and justice, but fails in its operation, and that in a manner which presses so hard on staff and regimental surgeons, that I wonder it did not occur to the framers of these rates, and that it has not already been especially pointed out through the medium of your columns. Staff and regimental surgeons, after twenty years' service on full pay, were by former regulations entitled to ten shillings per diem, if obliged to retire on account of ill health; but according to the present, the state of their health on retiring is not taken into consideration, and by it, though retiring from ill health, they are only entitled to the inferior rate. Of this regulation I conceive medical officers who entered the service before its promulgation have just reason to complain; but the semblance of injustice would be less evident, if by the same warrant ill health did not expressly entitle other classes of officers on retiring to a superior rate of half-pay, an advantage which, by the by, former regulations did not give. This is turning the tables upon the poor medical officer with a vengeance. The standard by which his pittance on retiring from the service is henceforth to be meted is depreciated, whilst that of his brother officers is enhanced. Of what enormity has the medical department been guilty that they should be thus served out? surely amendment or explanation is here required.

By the late warrant regulating the appointments and pay of army medical officers, the different grade of ranks and commissions has been defined, but how does it operate in practice? The commissions of staff and regimental surgeons still clash. A number of staff surgeons have been appointed to regiments, and we find in the Army List, besides the date of their regimental appointment, that of "Forces" appended to their names. Now it might happen that one of these regimental staff surgeons was in garrison with a junior staff surgeon, in which case who would be principal medical officer? In analogous circumstances, officers with brevet rank are not allowed to serve in garrisons where their rank would interfere with that of the chief, or officer commanding. And again, if a staff surgeon serving with a regiment is to derive no advantage from his rank, a senior regimental surgeon would rank before him. These may appear trivial observations, but on such trifles the comfort and respectability of worthy individuals may hinge, and it becomes those who have the power, so to regulate the department, as to obviate, if possible, any jealous or unpleasant feelings which might arise from their occurrence.

All men naturally are desirous of distinction, and trifles often serve to elevate or debase us, not only in our own estimation, but in that of others. The staff surgeons employed in regiments, have in the Army List the date of their staff commission appended—why should not surgeons on the staff have the date of their regimental appointment as such also stated? It would distinguish old and meritorious surgeons, who have only lately accepted of the staff appointment, from their juniors in the service, who now figure as senior surgeons on the staff.

Regimental *assistant*-surgeons, when appointed to the staff, take precedence, according to the date of their regimental appointment, with staff

assistants. I cannot understand why regimental *surgeons*, when placed on the staff, should *not* possess the same advantage with regard to staff surgeons. Many of the staff surgeons now on the List, were only assistants when promoted to that rank, and according to the present discordant system, they are suffered to retain their station on the List, to the prejudice of those whose assistants they formerly were.

Hoping you will give insertion to these remarks, I remain,
Your constant reader,
UNUS QUORUM.

June 1831.

State of the Royal Marines.

MR. EDITOR,—On perusing your valuable Journal the other day, I observed a letter respecting the neglected state of the Royal Marines, which induced me to make inquiry as to the fact, and sorry am I to find that it is too true; yet it appears extraordinary it should be the case, when they have so repeatedly received the thanks of both Houses of Parliament, and it is well known that the nation appreciate their services: his present Majesty's *most gracious speech*, when Lord High Admiral, on presenting new colours to each division; his great kindness in recollecting them on his mounting the throne of his ancestors, by presenting to each division his picture; his public letter read to the corps on his relinquishing the Generalship of it, was and is most flattering and gratifying; but, Sir, when I tell you that its officers are the *worst paid* and the worst provided for in the way of promotion of all His Majesty's forces, you will without doubt think with them that they have been neglected by the Board under which they serve. In the first place, every Captain in the Line receives 11s. 7d. per diem, Captains of Marines only 10s. 6d. the Royal Artillery and the Royal Marine Artillery 20l. per annum non-effective, in lieu of 1s. 1d. per day. Why *this difference*? Have they not fought and bled for their country? Are they wanting in zeal and loyalty to their King and country? No, Sir; on these points they will yield to no corps whatever, and all they ask for is equal remuneration.

Would you suppose (the nation, I am confident, cannot be aware of it) that their senior captains entered the service in the year 1795; their lieutenants are twenty-six and their ensigns nineteen years in the corps, consequently many of them nearly worn out; yet they are, and ever were, *tout pour pret* to fulfil their regimental motto, '*Per Mare et Terram.*' Their proportion of field-officers to 10,000 men in four divisions, including 400 artillery, are one general, resident in London, four colonel-commandants, eight lieutenant-colonels, eight majors, and one major to the artillery—total twenty-two. This is a small proportion when compared with any other corps. No less than twenty-four companies have been added during the peace, but not one field-officer. A circumstance of this kind would have been deemed very extraordinary, if not cruel, in any other branch of His Majesty's service. The sinecures of the corps, and by them considered their *bane*, consist of no less than seven appointments,—three generals and four colonels, at 20l. per day, or at about 7300l. per annum. These appointments are given to officers of the Navy, who are well provided for in that most honourable service, and really have no more to do with the corps than you have. It is heart-breaking to its officers to observe the sweets of promotion going on in every other corps. The rank of major has been abolished of late in the Royal Artillery and Royal Staff Corps, without additional pay, until within the prescribed number of established lieutenant-colonels of their respective regiments. The Engineers have the same indulgence. Why not grant the same privilege to the Royal Marines, as these corps assimilate nearer than any other? that is, they rise progressively; and when it is considered that there are at present only eight majors, *one having already from length of*

service attained to the brevet of lieutenant-colonel, it certainly is not asking for too much. This would prevent the humiliating feeling of junior officers becoming seniors, as is now the case. The corps view with much regret the re-appointment of Brevet Lieutenant-Colonel Torrens from the reserved half-pay; that is, to his being placed on the list where he originally stood before he went on half-pay (*which he did*) to suit his own convenience, this being diametrically opposed to the constitution of the corps, to His Most Gracious Majesty's order of the 15th of August 1827, when Lord High Admiral, to the usage of the Army, and to every principle of justice. I find that this is not the first appointment of the kind. A lieutenant-colonel, three brevet majors, and one captain, were a short time previous to the re-appointment of this officer brought in from the half-pay, where they had been for many years (by their own request) and placed over the heads of officers who had been serving in all climates, and had faced the perils and dangers of war without shrinking from their posts. Not disputing the power of the Admiralty, the officers of the corps must, and no doubt do, feel the injustice of others being placed over their heads. Before this cruel mode was adopted, an officer flattered himself that if Nature had endowed him with strength of body, and a sufficient stock of that necessary ingredient *patience*, he would at last, in his old age, be able to retire as a field officer; and this idea alone, no doubt, induced many parents to place their sons in this hitherto respectable corps. Deprive them of this hope, and you destroy the *esprit de corps* of nine-tenths of its officers. Independent of the feelings of the officers thus treated and neglected, what will be the state of this corps in a few years hence? I heard it remarked by an Admiral the other day, that many of the subalterns were as old as himself—scarce any fit for foreign service. They will be worn down by age and disappointment, but will descend to their graves with this consolation, that, although neglected and forgotten, the Royal Marines ever did their duty. I have only to add, that in these times of economy, much may be done without burthening the country with any great additional expense, to renovate a corps, and reward men whose services were ever held in the highest estimation, and to a maritime nation like Great Britain, of some consideration. The sinecures alone, by being permitted to die off, would give them twenty field officers, the corps then would have only two-thirds of the army proportion to 10,000 men. Abolishing the rank of major would induce the old officers to dispose of their commissions, thus providing for their families, and making room for younger and more active men. Trusting that Government will take into its most serious consideration this meritorious body,

I remain, Mr. Editor,

A FRIEND TO MY COUNTRY AND TO THE
WOODEN WALLS OF OLD ENGLAND.

The Corps of Gentlemen Pensioners.

MR. EDITOR,—Feeling assured that you would not allow your pages to be the medium of misrepresentation, I shall offer no apology for presenting the following remarks in answer to a letter in your Number for April, on the subject of the Band of Gentlemen Pensioners.

Your correspondent observes, that “in these days of economy and retrenchment, it is really too bad that the country should be put to a heavy expense in paying a party of London Tradesmen for acting as *gardes du corps* to His Majesty,” and proposes as a remedy, that the vacancies should be filled up from veteran half-pay officers, who are to be of a certain height (!) and the corps to be officered by retired Generals.

With reference to the sneer at the rank in life of the gentlemen composing the Band, and who are, in another part of your correspondent's letter,

eloquently designated as "an awkward squad of London Tradesmen," I have to observe, that the corps are, in point of birth, education, and fortune, equal to the same number of officers in most regiments; several possess large fortune, all are of independent property, and very few are in any way connected with trade. But even admitting they were so engaged, let me ask your aristocratical correspondent from what class the army was principally officered during the war? As far as my experience goes, (which is from my childhood,) from the very class he so needlessly asperses. The corps has amongst its members, officers both naval and military, who have shared the honours of some of the greatest actions in which the country has been engaged; and the objection of your correspondent with regard to trade has already been anticipated, by a regulation which has been some time adopted for the exclusion of persons so engaged.

It may be as well to inform your correspondent that the appointments are only obtained by purchase, and that the income barely pays common interest for the money invested; while the monstrous plan he proposes, of a corps of veteran officers, all of a certain height (!) to be commanded by Generals, would entail a considerable expense on the country, and no doubt in time lead to great abuses. The fact is, several of the economists have tried the subject, and found they could make nothing of it: and when next your correspondent feels inclined to make an exhibition in print, (in which he has made a more ridiculous figure than that he ascribes to the appearance of the *Gardes du Corps*,) I beg to warn him against the egregious error of meddling with a subject with which he is totally unacquainted.

I have the honour to be, Sir,
Your obedient servant,

A MEMBER OF THE BAND.

May 28th, 1831.

Suggestions on Drill.

MR. EDITOR,—As I believe the present system of drill as established by regulation is about to undergo some change, I wish to mention to you an idea that has occurred to me for the formation of four deep. The flank march by threes is, I believe, to be done away with in deployments, &c. and file marching substituted. Every one will, I think, acknowledge that the formation of fours for the purpose of deployments, when it can be done, is most excellent; the objection to it, according to the present system, being the length of the word of command, and consequent loss of time:—right, form four deep—march. I would propose for trial the following formation, by which that evil would be obviated. On the word, form four deep—march, the front rank man of the left file shall place himself in front of the right file, and the rear rank man of the left file in rear of the right file. In forming fours to the right, the whole will face to the right, and the front and rear rank men of the left file will place themselves in the same places, but faced to the right. In forming fours to the left, the whole face as before, but the left file stands fast, and the front rank man of the right file moves on the right of the left file, while his rear rank man places himself on the left. The formation of fours to the rear is the same as the first, only facing to the right about. This formation appears to me to offer the double advantage of simplicity, as compared with the present, and of offering a much more rapid formation to the right or left, by the word of command, fours right or left. It is applicable to all formations from line into column, and to all deployments into line, except from close column; as there is not sufficient room for the formation of four deep between the companies, when at only one pace distance, which I understand is in future to be the close column distance, instead of two paces, as at present.

I am, Sir,

Your obedient servant,
W.

May 27th, 1831.

Commander Lawrence on Leather Storm Sails.

MR. EDITOR,—It being a subject of congratulation to unpatronised inventors, who have devoted their time with the most anxious and unremitting attention in effecting naval improvements, that from their publication in your valuable Journal, so generally read by officers of the highest rank and experience, such discoveries are in consequence not only duly appreciated, but honoured with support, according to their merits:—encouraged by this consideration, I beg to submit my plan of Leather Storm Sails, and that such a durable storm-sail will be deemed of the highest importance to ships in sudden violent storms and dangerous lee-shores, their safety at such perilous periods mainly depending thereon. On various trials on board, the superiority of such sails has been decidedly proved, “being the only sail that could be shown,” together with their unparalleled durability for years.

Having learned with great satisfaction of a Board of Naval Officers recently who witnessed the trial of several inventions, both on board H. M. ships Donegal and Actæon, I cannot but express my solicitude that the Leather Sails may also be honoured with a similar trial;—presuming that many calamitous wrecks have been caused by the loss of sails, and also ships foundering at sea, many unknown, leaving not a wreck to record their melancholy fate.

I remain, Sir, your obedient,

J. LAWRENCE, Commander.

Indian Army versus that of St. Helena.

MR. EDITOR,—In your last Number I have read the complaint of Miles, on the slowness of promotion at St. Helena. With a minuteness worthy of approbation, he not only gives us the aggregate numbers of the armies of India, 4707 officers, of St. Helena 37, not counting fractions, but he adds the date, month, and year, of the rank of each at St. Helena, while he only favours us with the year of each rank at the Presidencies of Bengal, Madras, and Bombay.

Permit me in reply to your correspondent to observe, that as the whole of the East India Company's service is by *gradation* and by *regimental rise*, no one branch, I humbly apprehend, can have any just ground of complaint, or of jealousy against the other. That such does exist, the letter of Miles proves, and we have often, but with as little reason, heard the same reclamations on the continent of India. That it is wholly impossible for any Government to remedy mere partial or local disparities, where all have started fair under the same rule, must be obvious to “the meanest capacity.” Troops are not raised or augmented for the convenience of the officers, but for the exigencies of the state.

But in the case of St. Helena, there is a further reason for the slowness of promotion of which your correspondent complains, but which he has wholly overlooked. The troops at St. Helena never see any service, know not the pleasures of a march of 1500 miles, the luxuries of a campaign in the hot winds, or the paradise of a Rangoon or Arracan *bivouac* in the rains for six or eight months, with one servant, and that servant sick, as was my case; not to speak of the dry blows and other little *hors d'œuvres* and *entremets* in an Indian campaign, which are quite matters of history to the placid life of a St. Helena officer.

I have merely mentioned these matters, Sir, to account for the superior rise of the army of India over that of St. Helena. The St. Helena forces can lose no officers before the enemy, for they never see one: they have no marches, for the sea is everywhere within three miles of them: all their migrations are from Sandy Bay to James's Valley, or to Plantation House, or to Longwood; and excepting the ravines, I know no intervening danger: their climate is a paradise.

Many an old Indian officer who has spent his best days and blood in toil-

For Ab' is evidently the secant of $\angle b \cdot AT$, to radius AT . And Ae' , the chord of the supplement of double that angle. $e'b'$ is the difference of these two quantities. And $e'd' = e'b'$.

Hence, $A'd'$, and any absciss, or ordinate, are easily determined.

Then, if $AT, = TB, = TC = d'g$, be denoted by a , Ag will $= a + \sqrt{2a^2}$ by the conditions.

And as, $A'd' : \text{Rad} :: a : \text{Line } 22^\circ 30'$

Or as, $a + \sqrt{2a^2} : \text{Rad} :: a : \text{Tangent } 22^\circ 30'$.

The area of the curve $BdFTB$, (Fig. 2) is equal to the square $ABCB$, (or, which is the same thing, to the square of Tg , in Fig. 1.)

For on TC , erect a square, and draw the diagonal $BC = AB$. Draw also, $Co = Cb = Cd$.

The triangles or semisquares BCh , and BCT , are equal and similar. $Co = Cb$, and Co is \perp to, and bisects bd . $\therefore \angle dCo = \angle oCb$.

The $\angle oCB = \angle BCb$, $\therefore \angle BCd = 3 \angle oCB$.

And as the like is true of all the infinitely numerous angles into which the angle BCh is divisible, it is evident that the curve BdF , is generated by the triplication of the semisquare BCh , which may be conceived to expand like a fan, until the side Ch coincides with CF . When the angle BCF becomes $= 3 \angle BCh$.

Therefore, as the sum of the differences of all these infinitely numerous angles, is tripled in the angle BCF , (while their common vertex C , and the values of their sides remain unaltered,) so likewise is the sum of all the infinitely small differences of their areas, tripled in the curvilinear area $BdFCB$.

Hence, the area $BdFTB$ is equal to the square $ABCB$. Or if the curve be completed, by carrying it round on the opposite side of the line AF , then the entire area $BdFBTB$, will be equal to the square of AC .

A very simple instrument for mechanically trisecting an angle, may be made by cutting a piece of card, wood, or ivory, in the shape of the curve; distinguishing the point C by an indentation, thus—

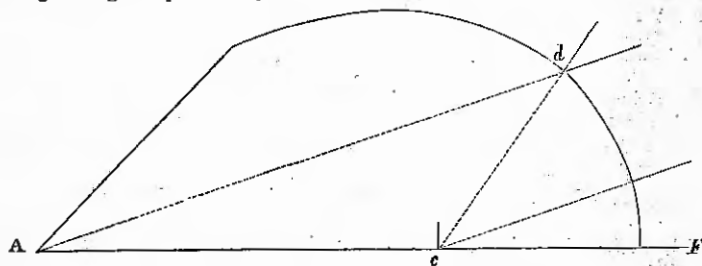

Then, if dCF , be any given angle, apply the base of the instrument to the side CF , and the mark at C to the vertex. Note the points A and d , and remove the instrument. Join $A'd$, and then a right line parallel therewith, and cutting C , will trisect the angle dCF .

EDITOR'S PORTFOLIO ;

OR

NAVAL AND MILITARY REGISTER.

AFFAIRS AT HOME AND ABROAD.

—The article on "Reform" at the commencement of our present Number, circumscribes our usual comments on passing events at home.

The Reform question was again introduced, in an unmitigated shape, by Lord John Russell, on Friday the 24th inst., His Majesty having opened the Parliament by a Speech from the Throne on the previous Tuesday. The Bill was brought in, and read on Saturday, and was ordered to be read a second time on Monday the 4th July. In its present form it will be warmly opposed.

Serious riots have occurred at Merthyr Tydfil, the centre of an extensive mining district in Wales, in which little, if any, distress is stated to exist. These daring excesses were suppressed, with some loss of life, by the steadiness and resolution of the few troops who could be brought to the spot. We give the details in another place.

Ireland continues disturbed by partial insurrection, while in other districts it is wasted by famine. A sanguinary affray recently took place at Newtownbarry between the country people, and the police supported by the yeomanry. The former had fire-arms, were apparently organised, and attacked the Yeomanry, who retaliated, as it would appear, in self-defence, after one of their number had been shot, and several wounded. What have not the ruthless Agitators of that unhappy country to answer for!

Extraordinary vicissitudes, though unattended with decisive results,

have marked the operations of the belligerents in POLAND, since the occurrences included in our last notice.

The Polish commander, suddenly breaking through the Russian line by one of those bold, though rash movements which have distinguished his active tactics, advanced rapidly to the north by the Narew, driving the feeble links of the Russian chain before him; and having occupied Lomza, a fortified post, and reached Tycozin, within a short distance of Bialystock on the Wilna Road, garrisoned by the Russian Guards, he succeeded in throwing the respective corps of Generals Chlapowski and Gielgud into Lithuania, to aid and stimulate the insurgents of that province. This was the ostensible object of his irruption.

The consequences of a movement so hazardous, in a military sense, did not, however, escape the vigilance of Count Diebitsch, who, rallying from the torpor and depression of baffled schemes and thwarted pretensions, made an effort, though without adequate promptitude and vigour, to cut off the main Polish army from Praga. Retiring at first from the Bug to concentrate a sufficient force, he made a flank attack on Skrzynecki, then in full retreat. The encounter took place at Ostrolenka, on the Narew, to the advantage of the Russians, though the gallant Pole cut his way through, and precipitately retreated on Praga. Here he remained for some time to refresh his troops and repair his losses. On the 14th June, the Po-

lish Commander again advanced, with the avowed determination of striking a decisive blow.

Meanwhile the several corps thrown into Lithuania are stated to have gained advantages in the field, and to have succeeded in rousing and sustaining the spirit of insurrection.

There has been a fatality throughout this war, favourable to the Poles. Amongst its signs we may enumerate—the frozen bridges of the Vistula gliding suddenly away—the cholera waging an exterminating war upon their ill-provided opponents—disunion and fatigue paralysing the hostile army—and, in fine, the “Balkan-passer” checked, distracted by difficulties, and undermined, at length succumbing to his altered destiny by taking refuge in—the grave. Count Diebitsch died, as variously stated, of apoplexy or cholera, at his head-quarters near Pultusk, on the 10th of June.

Count Paskewitsch Erivanski, his victorious co-operator by the line of the Caucasus in the war of Turkey, is expected to succeed him.

OF FRANCE there is little new to be recorded. The march of anarchy proceeds, denoted by those periodical outbreaks of popular licentiousness, which ever and anon convulse society, and shake to its foundation the flimsy fabric of government in that bankrupt and besotted country. Paris has been the scene of renewed disorders—the King has been insulted in the course of his tour through the Provinces of the Rhine—Russia, it is stated, has been equally uncivil, for which summary reprisals are threatened—a mighty expedition is destined to chastise the “insolence” of Don Miguel, at which Spain very naturally waxes wroth;—and, in truth, it will be a miracle if our Gallic neighbours do not find *some* outlet for their martial spirit and overgrown army.

The BELGIANS have formally

elected Prince Leopold as their King by a large majority of the Congress; but there being two parties to this election, it is not yet confirmed, although it is expected His Royal Highness will accept the proffered Crown, upon suitable conditions. The deputation sent to offer it has returned to Brussels with his ultimatum, which is supposed to be in the affirmative. Gen. Chassé has been compelled to restrain the Rabble of Antwerp by the only arguments of any weight with “*les Braves Belges.*”

A revolution has been enacted in the enlightened empire of BRAZIL. A revolt was got up at Rio by a handful of ignorant conspirators, which so disgusted Don Pedro, who deemed himself *par excellence* the Constitutional Emperor of either world, that he abdicated the sceptre of that magnificent country and its semi-savage population in favour of his son, an unhappy infant.

The Ex-Emperor has been rusticating, after the fashion of Dioclesian, on the soil of Liberal France, having come to Europe in H. M. Ship Volage, Lord Colchester. His Ex-Majesty has arrived in London.

IN TURKEY a serious insurrection of the Albanians, under the Pasha of Scutari, has been defeated by the Grand Vizier; by which success, the power of Sultan Mahmoud appears to be still further confirmed.

GREECE is the theatre of renewed convulsions, and appears as far removed as ever from the blessings of peace, or the security of life or property. Without established Institutions, or a Government entitled to respect, what does the nominal Freedom of these wayward Greeks avail them? It cannot even protect them from themselves.

In the VALAIS, there have been also disturbances. Who that knows that sterile Region of *Cretins* and Imbecility will ascribe this movement to the March of Intellect?

NAVAL AND MILITARY LIBRARY AND MUSEUM.

On Saturday the 25th of June, a general meeting of Naval and Military Officers took place at the Thatched House, St. James's-street, at two o'clock, to adopt resolutions for the definitive establishment of a NAVAL AND MILITARY LIBRARY AND MUSEUM: Major-Gen. Sir Howard Douglas, Bart. in the Chair.

The Chairman in opening the business of the meeting spoke as follows:— In attending the present meeting, I certainly did not expect to have been called upon to fill this honourable situation, and least of all should I expect to do so in the presence of so many distinguished and leading characters, far better qualified than I can pretend to be to discharge the duties of Chairman of this meeting; but since it seems to be the pleasure of the gentlemen now assembled that I should fill the chair, I readily acquiesce, deferring to their wishes, rather than yielding to any consciousness of my own fitness. The only consideration which would make it at all appropriate for me to preside on the present occasion, is, that I feel in my nature, my inclinations, my pursuits, and my affections, much in common with the two great professions, so many members of which I have now the honour to address. I have given much and close attention to the science and the practice of both professions, and I may, therefore, in some sort be considered amphibious. It accordingly affords me peculiar satisfaction to assist in bringing into existence a project which is likely to have the effect of associating in closer bonds of amity and union, the members of both branches of the service, and of affording to them in conjunction, increased facilities for acquiring precise and extensive information on professional subjects, and for augmenting their stock of general knowledge. It is, of course, known to all whom I have now the honour to address, that the particulars of the proposed institution have been for some time before the public, and that since the issue of the circulars, the Provisional Committee has been engaged in maturing a plan which will now be submitted to the meeting.

The regular course I conceive will be, in the first place, for the Secretary to read the Report of that Committee, and then every gentleman who has a resolution to propose or to second will be heard in due order.

The question was then put and agreed to, that the Report be read.

The Chairman—I have omitted to state, that Lord Rosslyn was expected to have taken the chair upon this occasion, but the sudden death of a near relative has unhappily deprived us of his presence and of his presidential assistance at this meeting. His Lordship has written the following letter apologising for absence.

“St. James's-square, June 23rd 1831.

“SIR,—I am extremely sorry to inform you, that the death of Lord Robert Spencer, a very near relation of mine, will make it impossible for me to have the honour of presiding at, or attending the meeting called on the 25th instant for the establishment of the United Service Museum.

“I must, therefore, beg you to make my excuse to the Committee, and to assure them that I shall have great pleasure in promoting the success of the object they have in view by every means in my power.

“I have the honour to be your most
“dutiful and obedient servant,
“ROSSLYN.

“Com. Downes, R.N.”

Commander Downes, R.N. one of the Secretaries, read the circular,* under which the meeting was convened.

Lieut. Hall, the other Secretary, then read the following Report of the Provisional Committee.

REPORT.

The Provisional Committee having completed the duty for which it was originally formed, beg to submit a brief notice of its proceedings, and to state the grounds upon which it has considered itself authorized to call this General Meeting. In consequence of a want of a suitable Establishment for promoting the objects detailed in the Circular which has just been read, a want long felt and strongly expressed by officers of both services, a meeting took place on the 16th of December

* A copy of the Article on this subject in our last Number.

1829, with a view to concert the necessary measures for founding such an Institution.

At that Meeting a Provisional Committee was formed for fulfilling this object, composed of—

Major-Gen. Sir Howard Douglas, Bart.
Chairman.

Lieut.-Gen. Sir Herbert Taylor.

Capt. Beaufort, R.N.

(The late) Gen. Sir Samuel Bentham.

Lieut.-Colonel D'Aguiar.

Capt. W. H. Smyth, R.N.

Lieut.-Colonel Grey.

Major Sir Robert Kerr Porter.

Major Garvoek.

Commander Downes, R.N.

Major T. H. S. Clerke.

Capt. Cooke.

Lieut. Hall.

Many incidental circumstances prevented a rapid progress in the preliminary measures requisite for its formation; but the Committee have the satisfaction to state that during the entire period of its existence, a strong feeling has been constantly manifested by the Members of the profession in favour of the design.

In the early part of the present year the Committee received a most gratifying communication from Sir Herbert Taylor, conveying the gracious intentions of his present Majesty to continue to the Institution that patronage, which, as Duke of Clarence, his Majesty had been pleased to bestow upon it: also that his Grace the Duke of Wellington had expressed himself favourably of the proposed Institution, and intimated his wishes to promote its establishment. His Grace has since accepted the office of Vice Patron.

Under such important and gratifying auspices, the Committee proceeded to adopt immediate and effective measures for its complete organization, and to this end, several of the most distinguished officers in the several branches of the service have been requested to take upon themselves the respective offices of Presidents and Vice Presidents; a list of whom will be submitted to this Meeting for its adoption.

The Committee finally proceeded to issue circulars explanatory of the design, accompanied by a form for the signature of officers, to every ship and regiment in his Majesty's service, and likewise circulars to individual officers residing in the metropolis. This measure has been attended with the anticipated result, for although not more than three weeks have elapsed since their issue, a period too short to receive back replies from any of our

foreign possessions, the Committee has the satisfaction to announce that the present number of Members amounts to 735, of whom fifty are Life Subscribers.

The Committee having proceeded thus far, this General Meeting of the United Service has been convened, to adopt Resolutions for its definitive organization; and on closing their labours, the officers composing it feel confident that such measures will issue from the Meeting, as at once to place the Institution on such a basis, that the objects contemplated by its formation will be fully attained, and that the Naval and Military Museum will prove useful and creditable to the United Services, as well as advantageous to the country.

Major-Gen. Sir Henry Hardinge.—

In the absence of Admiral Sir Henry Blackwood, I find myself called upon to move the first Resolution. In submitting this to the consideration of the meeting, I must begin by observing, that there is no officer at all acquainted with the character of his Majesty, who must not be fully aware that the Sovereign would be the very first person in the Empire inclined to patronise and support an Institution so well calculated to advance the interests and improve the character of the two professions, as that which we are now assembled for the purpose of establishing. Evidence of such sentiments we have in the fact, that his Majesty now, when Sovereign, is equally ready, as when Lord High Admiral, to advance this laudable and excellent undertaking. If we sought for illustrations of the value of our proposed institution, one at least would be suggested to us by the presence of my gallant friend now in the chair. It is probably known to many whom I have the honour to address, that my gallant friend has written an admirable Treatise upon the subject of Military Bridges; it is a treatise which has been translated into the German and French languages, and has become as it were a class-book amongst the members of our profession on the Continent. Now, there are principles in that book the most obvious and the most useful—obvious with the aid of a model, which are yet exceedingly difficult to be understood without the benefit of that assistance. Thus then do we propose to afford all writers upon similar sub-

jects, and all students of their works, those aids which drawings and models alone can supply. I might enforce this by a variety of reasonings, and almost every Naval or Military work would furnish me with the means of illustration. But as I have given one case from my own profession, I trust I may be allowed to give a second from the other department of the service. There is the case of carronade carriages. My late duties at the Ordnance Office brought it within my knowledge, that for fifteen or twenty years the subject of carronade-carriages was made matter of dispute; but had the profession generally a good supply of models and easy access to them—models displaying the views of every ingenious projector on the matter, how much more readily would just principles have been adopted, and how much fewer would have been the disputes; by how much less the uncertainty! I need scarcely point your attention to the vast advantages that would accrue to the profession from having a complete and extensive Museum, in which would be chronologically arranged models showing at a view the improvements, by means of which any thing now in use has been brought to its present state of perfection. As an example of the unequal state of the different departments of military science and art, and a proof how much an institution of the sort contemplated is now required—an institution which would prevent one part of the service from falling far behind the others,—I will mention a fact. The pontoons we had throughout all the campaigns on the Peninsula did not contain the slightest improvement upon those used in the time of Marlborough; they were quite as cumbersome and as difficult to be transported over land; they very readily received water, and when the water once came in, both bridge and boats were in imminent danger of being swept away. Since the war, no doubt, a far better species of pontoon has been invented, which can be transported with half the number of horses, and which in half an hour can be made available for transporting artillery across wide and rapid rivers. That was a vast improvement. There are various other improvements which

have been made, but for which we should not have had to wait so long, if the inventive genius of the profession possessed those facilities and advantages which we now propose to open. Here, I trust, we shall not only have treatises to read, but models and the drawings which illustrate those treatises, and render them more useful and practical. Having thus very briefly stated my views on this interesting and important undertaking, it is not my intention to trouble the meeting with any farther remarks. I shall merely content myself with reading the Resolution which has been put into my hands, and which is as follows:—

Resolved, 1st. His Majesty having graciously condescended to patronize the proposed Institution, that it be now formed and designated.—

“THE NAVAL AND MILITARY MUSEUM.”

Sir Henry continued.—Having read to you the Resolution in the precise terms in which it was put into my hands, I will now, with the permission of my gallant friend in the chair, take the liberty of suggesting, what I conceive would be an improvement in the wording of the Resolution, namely, that instead of our new establishment being called the “Naval and Military Museum,” it should be called, “THE NAVAL AND MILITARY LIBRARY AND MUSEUM.”

Capt. Beaufort, R.N. in seconding the foregoing Resolution said, All the Navy, I may say, are now intent upon having a Naval School; I hope they will succeed in that object; and all who feel an interest therein, must also desire to promote the object for which the present meeting is assembled; for the Library and Museum will be but following up that plan. In another point of view, I would most earnestly recommend it to the support and favour of those who feel an interest in the honour, and character, and happiness of the members of both professions, for I confess I am sanguine enough to hope, that our Library and Museum will detach many of our friends from the club-house and the billiard-table.

The Resolution (the word “Library” being inserted before Museum) was then put and agreed to.

Admiral Sir Robert Stopford.—The proposed establishment has my most cordial good wishes, and shall have my very warmest support. In my opinion it should—and I have no doubt it will—meet with the support of the heads of all the departments connected with the service, Army, Ordnance, and Navy. Those who have had a practical opportunity of knowing how the matter really stands, will bear me out in the assertion, that many excellent schemes have been lost to the state from the impossibility of competent judges being made acquainted with their merits, or of examining and reporting upon them. The Navy Board are inundated with schemes, many of them very ingenious; but there is neither leisure nor means for attending to them, and I am sure that in consequence there have been a great many good things thrown away. But when an association, such as we now propose to form, shall have been matured, every invention can be submitted almost to the whole profession, at least to such a number as will be sufficient to afford a satisfactory decision with respect to it. Thus the good will be separated from the bad—the grain from the chaff. So far as my assistance can go individually, I shall render it most cheerfully, and I have no doubt the public Boards connected with the service, will promote the establishment of a Naval and Military Library and Museum, for it is a plan calculated to relieve them from a load of trouble. I have now to move the second Resolution, which is as follows:—

Resolved, 2ndly. That all officers of the Army, Navy, and Marines, Militia (Regular and Local) Yeomanry, East India Company's Land and Sea Forces, and Civil Functionaries attached to those departments, be eligible to become Members.

Major Clerke.—I have much pleasure in seconding this Resolution. I fully concur in the object which we are met to promote—an object which I have elsewhere strenuously endeavoured to forward.

Lieut.-Gen. Sir Robert Wilson.—In moving the next Resolution, I shall, as concisely as possible, express my most hearty concurrence in the proposed plan—a plan, which when car-

ried into effect, will be not only advantageous to the professions, but suitable and ornamental to the Metropolis, and advantageous to the general interests of the country. The present moment, I consider, highly favourable for the formation of such an establishment, but there is no time to be lost; for there are many valuable collections which will, I trust, be presented to you, but which, if you do not step in, may be dispersed; and there are others now undergoing the process of destruction, which you may be the means of saving. Again, this Association will form another link between the members of the two professions, affording further reasons for good understanding, mutual esteem, and brotherly affection between the Army and Navy. To bring to maturity a project of this nature, will require many judicious regulations, but at present we are of course occupied with voting mere elementary propositions necessary for decreeing the existence of such an establishment—one which, I hope, will obtain general approbation, and conciliate the good will of all classes. The Resolution put into my hand, is as follows:—

“Resolved, 3rdly. That His Grace the Duke of Wellington be the Vice Patron.”

Commander Dickson, R.N.—I cannot help expressing much exultation at taking part in the proceedings for the formation of an institution which, I trust, will prove ornamental and beneficial to the country. It will contribute to connect more closely than before the two services, to promote the best interests of the state, and to defend and support the throne. I have much pleasure in seconding the Resolution, which has just been proposed.—The Resolution put and agreed to.

Lieut.-Gen. Sir Rufane Donkin.—After the various observations which you have heard recommending the proposed plan to your adoption, it is unnecessary that I should detain you with any remarks of mine; I have been anticipated, however, by my Gallant Friend opposite (Sir R. Wilson) in one observation I had intended to make, that as institutions of this nature always have the effect of bringing members of both professions more frequently together, they are calculated to in-

crease confidence, attachment, and friendship; and that those feelings may be ever perpetuated amongst us is my most earnest wish. The following is the resolution which I have the honour to move:—

“Resolved, 4thly. That the First Lord of the Admiralty, the Commander-in-Chief of the Forces, the Vice-Admiral of Great Britain, the Master General of the Ordnance, the Lord Lieutenant of Ireland, and the General of Marines, be the Presidents, and that the number be limited to six, and that the following distinguished officers be Vice Presidents.”

Admiral Hon. Sir R. Stopford, G.C.B.

Gen. the Earl of Rosslyn, G.C.B.

Admiral Sir Charles Hamilton, Bart.

Gen. Lord W. Bentinck, G.C.B. and G.C.H.

Vice-Admiral Sir Thomas Byam Martin, G.C.B.

Gen. Hon. Sir Edward Paget, G.C.B.

Vice-Admiral Right Hon. Sir George Cockburn, G.C.B.

Gen. Lord Viscount Combermere, G.C.B. and G.C.H.

Vice-Admiral Sir Henry W. Bayntun, K.C.B.

Gen. Lord Viscount Beresford, G.C.B. and G.C.H.

Vice-Admiral Sir Edward Griffith Colpoys, K.C.B.

Gen. Hon. Sir A. Hope, G.C.B. M.P.

Vice-Admiral Hon. Charles Elphinstone Fleeming.

Lieut.-Gen. Sir Rufane Shaw Donkin, K.C.B. and G.C.H.

Vice-Admiral the Hon. Sir Henry Hotham, K.C.B.

Lieut.-Gen. Sir George Murray, G.C.B. and G.C.H. M.P.

Vice-Admiral Sir Josias Rowley, Bart. K.C.B.

Lieut.-Gen. Sir Thomas M. Brisbane, G.C.B. and G.C.H.

Vice-Admiral Sir E. Codrington, G.C.B.

Lieut.-Gen. Sir Herbert Taylor, G.C.H.

Vice-Admiral Sir Henry Blackwood, Bart. K.C.B.

Lieut.-Gen. Sir R. Hussey Vivian, Bart. K.C.B. and G.C.H.

Vice-Admiral Sir John Poo Beresford, Bart. K.C.B.

Major-Gen. J. Macdonald, Adjutant-General.

Rear-Admiral Sir Thomas Masterman Hardy, Bart. K.C.B.

Major-Gen. Sir Alexander Brice, K.C.H.

Rear-Admiral Right Hon. Lord James O'Bryen.

Major-Gen. F. W. Mulcaster.

Major-Gen. Sir Henry Hardinge, K.C.B. M.P.

Director-General Sir James M'Grigor, Knt. M.D.

Major Garvoek seconded this resolution, which was put and agreed to.

Colonel Lord Frederick Fitz-Clarence moved the fifth resolution, which was in the following terms:—

“Resolved, 5thly. That the management of the Institution be vested in a Council, to consist of the Vice Patron, Presidents and Vice Presidents, and a Committee of thirty Members to be elected by the Society, and that seven shall form a quorum.”

Seconded by *Doctor Macann*, Medical Staff.

Lieut. Drummond, R. E. in reference to the good effects which such an institution would have in making the members of the profession early acquainted with the several useful discoveries applicable to their duties, observed that there had been recently a beautiful application of a new principle to correct the irregularities of the compass in high latitudes. It was first used in the late Northern expedition, and was one of those contrivances highly ingenious and eminently useful, of which no verbal description could convey an adequate notion, and which could never be clearly understood without the aid of a model. A paper had lately been read upon the subject by Mr. Barlow, the inventor, before the Royal Society, and there could be no doubt that the discovery was one of eminent utility to the naval service, for it had been found to correct an error of a mile and a half in a distance of ten miles, which, in a narrow channel, and on a dark night, might be productive of very fatal results, and often might be attributed to a current that had no existence. He apologised for having trespassed so long upon the attention of the meeting, but, having been educated under Professor Barlow, he hoped he might be excused for noticing an invention which, with the exception of Sir Humphrey Davy's safety-lamp, was the greatest benefit which Science had conferred upon Art.

The resolution was then put and agreed to.

"Resolved, 6thly. That the Council be impowered to fill up vacancies amongst the Presidents and Vice Presidents, as they may arise. That one third of the Members forming the Committee go out annually by rotation."

Colonel Salmon, in moving the next resolution, said he presumed it was put into his hands for no better reason than that he was an officer engaged in the service of the East India Company; he had much pleasure in moving the resolution.

It was seconded by *Capt. Lihou*, R.N. and, being put from the chair, was agreed to by the meeting. It was as follows:—

"Resolved, 7thly. That there be two Secretaries (one Naval the other Military,) and one Treasurer appointed by the Council. The two Secretaries to be extra Members of the Committee."

His Excellency Major-Gen. Nicolay moved the eighth resolution, which was seconded by *Lieut. Robe*, R.A., and agreed to.

"Resolved, 8thly. That the following Members compose the Committee for the first year, ending December 1831.—

Major-Gen. Sir Howard Douglas, Bart. Chairman.

Capt. Beaufort, R.N.

Capt. Francis Brace, R.N.

Capt. Norman Campbell, R.N.

Major T. H. S. Clerke.

Capt. Sir Francis Collier, C.B. R.N.

Major the Hon. W. L. F. De Roos.

Commander W. Dickson, R.N.

Colonel Sir Alexander Dickson, R.A., K.C.B., and K.C.H.

Lieut. Drummond, R.E.

Capt. the Hon. Henry Duncan, R.N.

Capt. Lord Adolphus Fitz Clarence, R.N.

Colonel Fox, Grenadier Guards

Major Garvoek, Assistant Adjutant General.

Capt. Basil Hall, R.N.

Lieut. Colonel Hanmer, R. H. Guards.

Colonel I. T. Jones, R.E.

Lieut.-Colonel Le Blanc.

Capt. Edward Lloyd, R.N.

Col. W. G. MacGregor.

Capt. Frederick Marryatt, R.N.

Colonel the Right Hon. the Earl of Munster.

Roderick Impey Murchison, Esq.

Capt. G. R. Sartorius, R.N.

Capt. W. H. Smyth, R.N.

Capt. Straith.

Colonel Walter Tremenheere, R.M.

Capt. Sir Thomas Trowbridge, Bart. R.N.

Colonel Sir Charles Brooke Vere, K.C.B.

Colonel Wood, Royal East Middlesex Militia.

Capt. Norton moved the ninth resolution, to the following effect:—

"Resolved, 9thly. That the thanks of this Meeting be given to the various individuals who have offered contributions, especially to the officers of the late Royal Staff Corps, to *Capt. W. H. Smyth*, R.N. to *Commander Downes*, R.N. and to *Messrs. Colburn and Bentley*."

which, being seconded by *Capt. Robe*, R.E., was likewise agreed to.

Lieut.-Col. Lord Brudenell—I have now to move a resolution, the purport of which I have no doubt will give as much satisfaction to the meeting as it affords to myself: it is that the thanks of this meeting be offered to our chairman for the able manner in which he has filled the chair this day. The ability and propriety with which he has discharged the duty of chairman must, I think, be evident to all present, and I am sure the vote of thanks to him will pass unanimously.

This having been seconded by *Capt. Blackhouse*, R.N. was carried by acclamation. The compliment was suitably acknowledged by the Chairman, who concluded the business by declaring that under the resolutions passed, THE NAVAL AND MILITARY LIBRARY AND MUSEUM was founded and constituted. Upon which the meeting dissolved.

CAVALRY BOARD.—The Board of General and Field Officers now sitting at the Office, 11 Duke-street, Westminster, to decide on a Revision of the Cavalry Movements, is composed of the following members:—

Gen. Lord Viscount Combermere, *President*;

Lieut.-Gen. Sir H. Fane,

Lieut.-Gen. Sir Colquhoun Grant,

Lieut.-Gen. Lord Edward Somerset,

Major-Gen. Kearney,

Lieut.-Colonel Thackwell, 15th Hussars

Lieut.-Colonel Stisted, 3rd Light Dragoons.

HALF YEARLY PUBLIC EXAMINATIONS AT THE ROYAL MILITARY COLLEGE.—The usual Half-yearly Public Examinations commenced at the Royal Military College at an early hour on Thursday, the 9th of June, and occupied the whole of that and the two following days. The Commissioners forming the Board of Examination, —besides General the Hon. Sir Edward Paget, the Governor, and Colonel Sir George Scovell, the Lieutenant Governor of the Institution, —were, Major-Gen. Sir Howard Douglas, Major-Gen. Macdonald, Adjutant-General, and Colonel the Earl of Munster. Among the officers of rank also present were, Gen. the Earl of Cavan, Lord Frederick FitzClarence and Colonel Fanshawe, of the Royal Engineers.

The examination of the officers studying at the Senior Department of the College, which was conducted principally by Sir Howard Douglas, with the ability for which he is distinguished, elicited very satisfactory proofs of the attainments of Lieutenants H. E. B. Hutchinson, 76th Regiment, and A. R. G. Thomas, 32nd Regiment, both of whom were presented with certificates of the highest class. A well executed military survey by these officers, of above thirty square miles of ground in Bedfordshire, was also exhibited; and the display of military drawings and sketches performed by the officers generally during the half-year, was extremely creditable to the department.

Two large and beautifully executed plans were also produced, showing the labours of the half-year in determining the trace and profiles, and in superintending the execution of the large Field Fort now in progress on the north side of the College, in a situation which seems, for the purposes of instruction, to have been judiciously chosen expressly to call forth all the resources of the engineer: another kind of practice consisted in tracing on the ground the parallels and approaches for a feigned attack on the works about the College, as military posts; the dimensions of these tracings being the same as for actual service, and the excavations on which had just been commenced by the detachment

of Royal Sappers and Miners employed at the Institution.

Of the Gentlemen Cadets, the following, who had completed their qualifications by the result of these examinations, were recommended in the order of their acquirements and comparative merits, to the General Commanding-in-Chief, to receive commissions in the line without purchase:—

James Gates, John G. Champion, Martin M. Dillon, Christopher M. Wilson, Richard D. Baker, Edward C. Munns, and John Heatley.

The following were the classes of Gentlemen Cadets brought forward for examination on the present occasion:

I. In Mathematics nineteen, including two (Gentlemen Cadets Dillon and Champion) who, besides the regular course of Studies, were examined in Conic Sections and Spherical Trigonometry.

II. In Fortification, including the Principles of its Permanent Constructions, the processes of their Attack and Defence, the operations of Mining, and the whole theory and practice of Field-engineering, twelve Gentlemen Cadets were examined: all of whom had been instructed on the ground during the half-year, by means of the usual detachment of the Royal Sappers and Miners, in throwing up intrenchments, sapping, and hand-grenade practice. The Field Works constructed were a continuation of the lines of intrenchment noticed on former occasions, for which all the profiles and defilements had been set up by the Gentlemen Cadets themselves, who also had been made to work with the Sappers in the excavation of the ditch and the building of the parapet. Many of the courses of sod work had been laid and shaped wholly by the class, with a precision and neatness which made it difficult to distinguish their work from that of the Sappers; and by those who are acquainted with the skill attained by that excellent corps, under the able direction of Colonel Pasley, higher praise cannot be given.

A sketch was also laid on the Board-Room table, of a breast-work and abattis to cover a small post; which had been constructed near one of the College woods in a single day, by the

joint manual labour of the class of Gentlemen Cadets and detachment of Sappers. It appeared by the Journal of the Field Work Practice laid before the Commissioners, that neither the Professor nor even the Serjeant of the Sappers was permitted to be present during any part of this work, of which the whole superintendence was committed to Gentlemen Cadets Gates and Wilson.

III. In Military Surveying and Sketching, fourteen Gentlemen Cadets had completed the required course of instruction in the field; and five others, who finished it in December last, had now executed several additional sketches. The usual exhibition was also made of a number of landscape sketches from Nature, taken since the Spring by Gentlemen Cadets under Mr. Delamotte, in a style equally creditable to the master and pupils.

IV. In German, five Gentlemen Cadets were examined: the book from which they constructed passages, chosen at hazard, being the Peter der Grosse of Pfäum.

V. In Latin, nine; in the College expurgate edition of Juvenal.

VI. In French, eight. In this examination, the lead was taken by Lord Munster, who proved the qualifications of the class, by selecting various passages for them to construe from French into English, and *vice versa*, in Voltaire's Life of Charles and Southey's Life of Nelson.

VII. In History, eight. This was, beyond question, the most distinguished examination in the whole series; and the instantaneous readiness with which the class obeyed a frequent call to change their narrative from one period to another, both in the Roman and Modern History, sometimes to an earlier epoch, and sometimes to a later, as well as the clearness and elegance of expression, with which, in these transitions, the thread of the narrative was caught up and pursued by each individual in his own language, excited the admiration of the numerous auditory by which the Board Room was crowded.

EAST INDIA COMPANY'S MILITARY SEMINARY.—The half-yearly examination of this institution took place at Addiscombe on Thursday the 9th of

June, in the presence of the Chairman of the Honourable Company, Robert Campbell, Esq., several Directors, and a number of visitors; amongst whom was the learned Brahmin Ram-Mohun-Row. This personage excited much attention, and appeared himself not a little struck with the splendid receptacle and admirable means of education provided for those youths, who were destined to protect and preside over the interests of his native land.

After the usual course of examination, the general results of which were not quite equal to those we have witnessed on other occasions, the following Gentlemen Cadets of the First Class were named for commissions, viz.

Engineers.—Thomas Keighly, Alexander Cunningham, John Sturt, Gore Munbee, John Skirrow, Charles Orr.

Artillery.—Robert Warburton, Joseph Phillips, John Pottinger, John Goad, Francis Voyle, Andrew Macintire.

With twenty others appointed to the Infantry.

The Chairman then proceeded to distribute the prizes, of which seven were conferred on Gentleman Cadet Keighly, whose talents and conduct merited this distinction. Gentleman Cadet Cunningham, son of the Poet, was almost equally successful. The proceedings closed with an address from the Chairman, who referred in a very impressive manner to some disorders which had detracted from the usual good conduct of the Cadets during the half-year, and concluded with an admonition which we have no doubt will have the desired effect.

RIOTS AT MERTHYR TIDVIL. 93RD REGIMENT.—A numerous and disorderly assemblage of miners and other lawless persons, having committed violent outrages and breaches of the peace at Merthyr Tidvil and its vicinity, a party of the dépôt of the 93rd Highlanders, under Major Falls, was called with pressing speed by the local Magistrates from their quarters at Brecon, to the unprotected scene of riot. On the arrival at Merthyr of this handful of troops, considerably under one hundred men, they took post in front of the Castle Inn, where the Magistrates were assembled, and were audaciously

attacked by the mob, who, closing round, rushed suddenly and savagely upon the unprepared party, with a view to disarming and destroying them. In the first of these objects, notwithstanding the surprise, they but partially succeeded, the soldiers, with characteristic steadiness, at first struggling hand to hand and successfully with the "physical force" of their assailants, and then pouring in a fire which told with its usual effect, dispersing the insurgents to the neighbouring hills. Major Falls and several of the soldiers were seriously injured.

Deeply as we lament an affray attended with such fatal results, we think that the lesson thus furnished to certain classes of this country on the new doctrine of the physical force-principle, may not be unattended with advantage to the community. It proves two things—both the disposition of the lower orders of our countrymen to *act* upon the incendiary recommendations so industriously held out to them—and the inadequacy of mere brute force when directed against organized bodies, however inferior in numbers, constituted as the British troops are, and sternly resolved to do their duty. We can trace both in this instance, and in the equally deplorable affair of Newtownbarry in Ireland, the spirit and the means by which Mobs are now taught that they must infallibly and easily attain their violent ends against regular troops—a fatal delusion, which we would again lift our voice to dispel, ere more serious evils have accrued from its blind indulgence.

As to the contemptible clamour, fruitlessly attempted to be excited against the troops for their soldier-like and patriotic conduct on this occasion, as it has not been shared by a rational being, so it merits not our notice, nor that of our gallant comrades in question. There is but one course for British soldiers in every similar case—a resolute adherence to their defined duties and immediate orders,—upon their firm and upright, yet temperate execution of which the peace of society at this moment mainly depends.

In justice to our brother soldiers we cannot refrain from bringing forward the opinions of competent judges of their conduct, living on the spot, and

bearing impartial testimony to their public services and general deportment. It is gratifying to add that on the return of the 93rd to Brecon, they were met by the inhabitants, who, with cordial acclamations, regaled and escorted them back to their old quarters.

The following judicious remarks are extracted from "The Monmouthshire Merlin," an honest and influential provincial Journal. On such an occasion it is far more agreeable to us to adopt the discriminating and unbiassed language of our fellow-subjects than to employ our own.

"It is very easy for a well-educated Cockney gentleman, sitting tranquilly in an elbow-chair over a bottle of old port, to work himself into an ecstasy of enthusiasm on the subject of constitutional liberty—to quell, with a flourish of his pen, the fury of an excited multitude to which he has never been exposed—and to descant in eloquent terms upon the sanguinary exercise of military power. On the day preceding the fatal affray in which so many lives were lost, the Magistrates were unable to prevent the spoliation of Mr. Coffin's house, and the other acts of outrage then committed. Under these circumstances they were compelled to send for the military. About eighty of the 93rd Highlanders arrive from Brecon on Friday morning, after a hasty march of eighteen miles—they proceed to the Castle Hotel, amidst the insults and vituperations of a mob, comprising at least 10,000 men, emboldened by the success of their first attempts against the public peace, and determined for further mischief. The Riot Act is read—the Magistrates, one after another, address the mob, and entreat them to disperse. What is the reply? An attack upon the soldiers in front of the inn—a seizure of their arms—and an *actual attempt, by the populace, in which they nearly succeeded, to take the place by storm.* At this moment, and not before, orders are given to fire. Could human forbearance go further? Were the soldiers to stand quietly at their posts, while their comrades were being murdered, until it should come to their turn to undergo the same fate? By the law they would have been justified in firing on

the refusal of the mob to disperse after the reading of the Riot Act. Surely self-defence—self-preservation, was an excuse which would be admitted before the judgment-seat of Heaven! The idea of two or three magistrates and half a dozen constables being able to apprehend such a hody of rioters, consisting of men at whose herculean exertions of strength in their daily labour the comparatively effeminate Londoner would gape with astonishment, is perfectly ridiculous.”

PRESENTATION OF COLOURS TO THE 70TH REGIMENT.—On the birthday of our most Gracious Sovereign, this distinguished corps, mustering 700 bayonets, assembled on parade at Richmond Barrack, Dublin, previously to being marched off to the grand review in the Phoenix Park. The solemn and impressive ceremony of presenting a stand of colours to the 70th, had been reserved for a grand and suitable occasion. The befitting season of the first anniversary of our Monarch's natal day since his accession, was selected as the most appropriate for this imposing spectacle. The colours to be presented were two—one bearing the emblem of the Union, the other the devices of the 70th, in rich and tasteful embroidery—at once the workmanship and gift, (as we were informed,) of the fair and accomplished daughter of the officer in command of the regiment.

CHOLERA MORBUS QUARANTINE.—On this, at the present moment, engrossing subject, the following Proclamation has been issued by the Lords of His Majesty's Most Honourable Privy Council.

Whereas by an Act passed in the sixth year of the reign of King George the Fourth, intituled “An Act to repeal the several laws relating to the performance of quarantine, and to make other provisions in lieu thereof,” it is amongst other things enacted, that it shall and may be lawful for the Lords and others of his Majesty's Privy Council, or any two or more of them, to make such order as they shall see necessary and expedient upon any unforeseen emergency, or in any particular case or cases, with respect to any vessel arriving and having any infectious disease or distemper on board, or

on board of which any infectious disease or distemper may have appeared in the course of the voyage, or arriving under any other alarming or suspicious circumstances as to infection, although such vessels should not have come from any place from which his Majesty, his heirs or successors, by and with advice of his Privy Council, may have adjudged and declared it probable that the plague, or any such infectious disease or distemper, may be brought, and also with respect to the persons, goods, wares, merchandizes, and other articles as aforesaid on board the same, and that all such orders so made by the Lords or others of the Privy Council, or any two or more of them as aforesaid, shall be as good, valid, and effectual to all intents and purposes (as well with respect to the Commander, Master, or other person having the charge of any vessel, and all other persons on board the same, as with respect to any other person having any intercourse or communication with them, and to the penalties, forfeitures, and punishments to which they may respectively become liable,) as any order or orders made by his Majesty, his heirs, or successors, by and with the advice of his or their Privy Council, concerning quarantine, notified by the Proclamation, or published in *The London Gazette*.

And whereas advices have been received that the Cholera Morbus has lately been making alarming progress in certain provinces of the Russian Empire, it is hereby ordered in Council, that all vessels coming from, or arriving at, any port or place in Russia, and bound to any port or place in the United Kingdom, or to the islands of Guernsey, Jersey, Alderney, Sark or Man, (having clean hills of health,) as well as all vessels, boats, and persons having had communication with such vessels, shall proceed to such of the under-mentioned ports as may be nearest and most convenient to their port of destination, viz. — Cromarty Bay, in the Murray Frith, to the anchorage in the Frith of Tay, near Dundee, in the Frith of Forth, between the North Queen's Ferry and Lord Elgin's Limekilns; White Booth roads, between Hull and Grimsby; Standgate creek; the Motherbank; at Ports-

mouth; Plymouth; Falmouth; Milford-Haven; Comboro-pool, (in the river Mersey,) near Liverpool, Holyloch, in the Frith of Clyde; and shall there perform quarantine, and be subject, with their crews, pilots, and all persons having communication with such vessels, to all the rules and regulations established by his late Majesty's Order in Council, of the 19th July 1825.

And the Lords Commissioners of his Majesty's Treasury, the Commissioners for executing the office of Lord High Admiral of Great Britain, the Lord Warden of the Cinque Ports, the Master General, and the rest of the Principal Officers of the Ordnance, his Majesty's Secretary-at-War, and the Governor and Commanders-in-Chief for the time being, of the said isles of Guernsey, Alderney, Sark and Man, are to give the necessary directions herein as to them respectively may appertain. W. BATHURST.

BOARD OF HEALTH.—Besides the rigorous observation of quarantine, Government has established a Board of Health to instruct and direct the public, should the cholera be unhappily introduced to this country. Government has likewise received a very ample and most intelligent report from Sir A. Creighton, giving an account of the progress and decline of the cholera in Russia. It does not, however, appear, that any mode of treatment has been discovered as a cure for this dreadful malady. The learned writer describes the pains attendant upon it to be excruciating in the extreme.

ROYAL NAVAL SCHOOL.—A second meeting of Naval Officers was held at the Thatched-house Tavern, St. James's Street, on the 14th of June, for the purpose of taking into consideration the best mode of carrying into execution the plan for erecting a Royal Naval School, for the education of the sons of Naval and Marine officers. Among the officers present were Sir H. Blackwood, Sir T. Williams, Sir C. Rowley, Admiral Sotheron, Admiral Tollemache, Captain Dickson, and various other officers.—Lord Yarborough and Lord Manners were also present.—Sir H. Blackwood having been called to the chair,

Capt. Dickson read the report which he had been ordered to present at the

last meeting. He (Capt. D.) then stated, that his Majesty had been graciously pleased to declare his willingness to become the patron of the institution, and his approbation of the design as "one deserving of every encouragement." The report, after lamenting the deplorable death of Sir Joseph Yorke, the Chairman of the late meeting, proceeded to state, that the resolutions which were then passed had been adopted with the same ardour in all the naval ports, and that shares for the admission of pupils had been subscribed for in London, in Portsmouth, in Plymouth, in Southampton, in Exeter, in Bath, and in various other places. The report then proceeded to state that the Dukes of Northumberland and Richmond had expressed the most friendly feelings to the Society; that Lord Yarborough had signified his intention to take twelve shares; that Lieut. Lord Viscount Bangor, R.N. had transmitted a donation of £50. from Ireland, and had also given his name as an annual subscriber of £10, and that various other officers had taken from two to four shares each. The report concluded by stating, that the project was to establish an intermediate School, which, whilst it would not be so expensive as the Naval College, would obviate the humiliation which naturally attended the youth through life who might be educated with the sons of common seamen and marines. On concluding the report, Capt. Dickson read a series of resolutions to the meeting, one of which contained the thanks of the meeting to his Most Gracious Majesty, for the patronage which he had announced his intention to bestow on this institution.

By general acclamation this last resolution was carried first.

When the names of the committee were read over, it was proposed, and, after a desultory discussion carried, that three flag officers and Capt. Dickson should be appointed to select a committee, and to report thereon on Friday next to the meeting. The flag officers appointed for this duty were Sir H. Blackwood, Sir C. Rowley, and Sir T. Williams.

Considerable discussion then took place as to the best mode of accomplishing the objects of the institution. Nothing was, however, settled, and the meeting broke up at four o'clock, after voting

their thanks to Sir H. Blackwood and Capt. Dickson. Subscription books were opened in the room, and a number of shares were immediately taken.

The estimated sum for the erection of the proposed building is £12,000.

In the course of the day, Sir G. Martin asked Capt. Dickson what sum of money he thought would be requisite to pay for the erection of the proposed building? Capt. Dickson: £12,000, Sir.—Sir J. Martin: What sum is already subscribed?—Capt. Dickson: 100 shares have been taken; that, at £25 a share, will give £2,500.—Another Officer: What is the amount of annual subscriptions paid in?—Capt. Dickson: Little or nothing is paid in; but gentlemen have sent in their names as annual subscribers to the amount of £140. or thereabouts. Besides, no accounts have yet been sent in from Plymouth, and many officers, I know, have held back till they know what is done at this meeting. An officer could not doubt but that £12,000 would soon be raised for so important a national subject. At the same time he should propose that three distinct sets of books should be opened, one for donations to the buildings, another for shares, and a third for annual subscriptions, which was agreed to.

In furtherance of this great national object, several donations and subscriptions have since been received.

ROYAL GEOGRAPHICAL SOCIETY.—*June 13.*—John Barrow, Esq. V. P., in the chair.—A paper on the province of Arracan was read. The principal harbour, named "Kyook Phyoo," takes its name from the quantity of white pebbles thrown on its beach during the S.W. monsoon—the name signifying white stones. The province extends from lat. 20° 46' N. to 16° N., and is separated from the Burman territory by the Yeomandong mountains. Cheduba and Ramree are the principal islands on its coast. They are partly fertile, producing rice, cotton, silk, and indigo, but these are not raised in sufficient quantities for exportation. The population of the whole province amounts to about 200,000, and since it was ceded to the East India Company, has been kept in subjection by one regiment of sepoys. A regular dāk is established between Calcutta

and Arracan, passing through Chittagong, and reaches Landoway in about ten days. The inhabitants are a hardy and inoffensive race. Their only wants are supplied from their own resources, which they command independent of the aid of strangers. Their houses are formed mostly of the bamboo, being raised from the ground, and generally built amidst the jungle, surrounded by plantations of cotton, indigo, tobacco, &c. Their principal food consists of fish and rice, although there is no scarcity of buffaloes, bullocks, and poultry. The buffaloes are esteemed much by them, on account of their docile habits, and utility in treading out rice; and their surprise is great on finding strangers anxious for them on account of their meat, as they imagine by their eating of it they will become calves. Rice and fish were both exported from this country to the Mauritius lately, at a very moderate rate.

There are few persons who cannot read and write among the natives of Arracan, their records being kept on the palm leaf. Their alphabet consists of thirty-six characters, written from left to right. Their schools are under the management of the priests, two or three of whom belong to every village. Celibacy is maintained by the priests, who also adopt the custom of shaving their heads. Their dress consists of dirty-yellow cotton. Should a young priest be dissatisfied with his calling on account of its restrictions, he is always at liberty to return to his former condition, and marry whenever he pleases. The priests are a well-disposed set of men, not interfering in the concerns of their neighbours, unless referred to, which is often the case in any dispute, when they settle the matter by arbitration. These people are by no means given to that servile hypocrisy of their western neighbours, and bear an excellent character as to probity in general. In their dealings of every kind their word may be relied on. They demand the price they consider an article to be worth, and no more; although it is much to be feared they will lose these good traits in their communication with the natives of Bengal. The women are not kept secluded, and are attired much in the

Chinese style. Their present trade is carried on by means of coasting vessels, which carry their produce to Calcutta, as well as up the Irawaddy to Ava, or Rangoon. They obtain in exchange the silks of the latter countries, which are superior to their own, and preferred to any others brought by Europeans.

A communication was next read on the Himalaya Mountains. Latitude is of little importance in the consideration of climate on this lofty range. The whole is distributed like strata, and in one day a range may be passed through from the heat of the tropics to the limits of the hardy birch. The highest cultivation on the southern face of the lofty chain, occurs at a level of 10,000 feet, the crops being thin and poor. The maximum temperature in June, is 72°, and the mean of the whole year 42°. Forests continue to a height of 11,500 feet, but the trees decrease in size beyond this height.—The route across the pass of the Himalaya was thus described: The Lutley river was crossed at Wangtoo, by a bridge of ropes. The route from hence was due north, and attained a height of 11,000 feet. Perpetual snow occupied the loftiest regions, and had accumulated in enormous bodies. Huge masses frequently break loose by the heat of the sun, and fall with a tremendous noise into the abyss beneath, carrying with them whole acres of rocks. At sunrise the ground is covered with frost, the thermometer 23. At the height of 15,000, respiration was affected, and great debility and sluggishness were experienced. On encamping at night in the pass, increased motion in the blood produced giddiness, with pains in the head, and intolerable heat in the face and eyes, accompanied with dreadful thirst: in the morning the thermometer was at 6. The sensations produced by the rarefaction of the air are beyond all description. There is an anxiety, and sense of suffocation quite intolerable; on the slightest motion the breathing is hurried, and it is impossible to get a full respiration: the elasticity of the surface of the body is reduced, and, there being no sufficient counterbalance to the circ-

lation, the blood is precipitated through the relaxed system, deranging the whole. The extreme height of the pass is 16,500 feet, and it is flanked by peaks rising to 18,500. The crest of the pass is less sharp than others, and declines very gradually. As the Chinese frontier is approached, the country and scenery change; trees shrink from the arid atmosphere, and become stunted and few. Vegetation is sapless and scanty, and the mountains themselves soften into bluff masses. In July and August the air is humid, and clouds hang about the peaks like mists, and according to the variations in the density of the atmosphere, they sometimes roll down and settle in the bottom of the valley. There they rest motionless, until some atmospheric change setting them in agitation, they move off, and rising until the air can carry them no further, they form a belt round the crests of the peaks, which shoot through their sides and appear like islets in the ocean. Such are the general features of the country, through which the route to Sadak lies. The traveller in his course finds himself environed by cliffs, which are perpetually breaking loose. His daily occupation is climbing to the tops of mountains, and descending again to their base; at one time shivering on the verge of congelation, and at another oppressed by heat. Precipices of a frightful depth are often skirted by rude staircases of frail construction, and torrents are crossed by cradle bridges of twigs swinging in the wind.

On the conclusion of the above paper, the President announced the return of the Landers from Africa, having succeeded in coming down the Niger to the sea from Youri. He observed that the river was found to run first to the southward, then to the eastward, the S.E. and S.W. into the sea;—that in consequence of the lateness at which the journals had been received, there was no time to draw up any statement of their discoveries, but that by the next meeting he hoped that one would be prepared for the Society.

THE COURSE OF THE NIGER.—The discovery of the termination of the course

of the Niger will be of the greatest importance to geography, to our political power, and to civilization.

With regard to geography, perhaps the contradiction which was afforded by the various sources whence we derived our knowledge of the character of the interior of Africa, and of the course of, next to the Nile, the most renowned, and, as was considered from the same accounts, the greatest river of that country, has in late times given unlimited zest to the pursuit of further information, and has not in the least detracted from the pleasure with which we find that we are indebted to our countrymen for the solution of this all-absorbing problem. It appears that among the ancients, many facts connected with the geography of the interior of Africa were well known, which have still been an object of discussion among the moderns; and of these we may enumerate the occurrence of a large lake or marsh (for it is either, at different seasons of the year), whose real existence, beyond the speculations of geographers, was very unsatisfactorily established, until the journey of Denham and Clapperton; and the fact of the occurrence of a great river in the west, emptying itself into the ocean, though many were of opinion that it lost itself in an inland marsh, or in the desert, while others supported the opinion of its identity with the Nile of the Egyptians. The researches of Ptolemy and the Arabian geographers on the Nile of the Negroes, and in later times the travels of Leo Africanus, who was a Moor of Grenada, demonstrated the absurdity of this opinion; and how extraordinary that, in the boasted perfection of human intellect, it should have been broached several centuries afterwards, and that the barometric levellings of Bruce should have been necessary to enforce conviction! It is not at all improbable that Hanno, the Carthaginian, as advanced by Macqueen, reached the Bight of Benin, or of Biafra; and certainly the geographical information obtained on these countries by Herodotus and Edrisi was more accurate than the speculations of many modern geographers.

Observations had demonstrated to the moderns that no large river emptied itself into the ocean on the north-west coast,

though it required a more accurate acquaintance with the Senegal and the Gambia before it was fully ascertained that they were not the outlets of this great stream. The progress of navigation along the south-eastern shores of Africa also showed that no large river emptied itself into the sea along that coast; while the settlements of the Portuguese on the coast to the south of Cape Lopez, led them, at an early period, to adopt the opinion afterwards supported by Mungo Park and Mr. Barrow, that one or more of the rivers in their vicinity were the outlets of the great river of the interior of Africa. Two celebrated geographers, D'Anville and Major Rennell, however, espoused the theory of the waters emptying themselves into the Wangara, or great marsh; which argument underwent various modifications in the hands of different geographers; and though the probability of its emptying itself into the Gulf of Guinea had been pointed out on the continent, and vigorously supported in this country, an expedition was fitted out to explore the Congo or Zaire, which, though unfortunate to the individuals concerned, was yet satisfactory in a geographical point of view, and demonstrated that the rivers south of Cape Lopez were not the outlets of the waters of the Niger, and gave origin to a speculation which partook of all the characters of a romance of the desert, beneath the sands of which its author buried the gigantic stream, loaded with the waters of the Wangara or Lake Tchad, to make it flow into the Mediterranean at the Syrtis of the ancients.

In the history of geography there are no examples of greater perseverance and courageous determination than in the efforts made to triumph over the difficulties presented in the solution of this important question. Since 1815, there has scarcely a year passed in which a new attempt has not been made; and of these, if we recede a little farther back, twenty-five were made by our countrymen, fourteen by Frenchmen, two by Americans, and one by a German; of which but a small number, since the days of Houghton, have not fallen victims to their heroic devotions.

Mungo Park first observed the direction of the stream which had become as much an object of discussion as its ter-

mination; and, strange to say, after the present discovery, it will, in some parts of its course, still remain so. The unfortunate traveller just alluded to, previous to his descent of the river, obtained some information from Moors and from negroes, on its course by Timbuctoo. The Jinnie of Park is synonymous with Jenné, Giné, Djenné, of other writers, as Jenné has again been confounded with Kano or Kanno. It may be a figurative term—for the Jinnie of Park was on an island, as was the Jenné of the Moorish reports, while the Jenné of some travellers is at a short distance from the river. This cannot be the case with regard to Timbuctoo, which is visited by caravans twice a year from Morocco; nor is the name met with any where, except the two first syllables in the town of Timbo, which cannot be mistaken for Timbuctoo.

Major Laing had discovered the source of the Niger to be in the mountains of Loma, in $9^{\circ} 15'$ west latitude, and had ascertained its course for a short distance from its source. We were also aware of the existence of one or two streams joining the great river, or branching from it near Timbuctoo. De Lisle had marked a river Gambarra, on his maps drawn up for Louis XV., and not without good authority. This is the river coming from Houssa; and the Joliba of modern travellers is a river, we could prove, from the concurring testimony of a variety of sources, coming from the north-west, and joining its waters with, that is to say flowing into, the Niger, in the immediate neighbourhood of Timbuctoo; still at that point the Kowarra, or Quorra of the Moors, or Quolla of the negroes, who always change the *r* for *l*; a name which, according to Laing, it has at its sources—according to Clapperton, it preserves beyond Timbuctoo, and is probably still the name of the same stream at its embouchure in the Bight of Biafra. The Quarrama is another tributary stream which passes by Saccatoo, and falls into the Quorra above Yonri, and above the point where Mungo Park was wrecked; and the line of country between this river and the Shashum, comprising the hills of Doochee, of Naroo, and of Dull, is the line of water-shed to the rivers joining the Quorra on the one hand, and

those emptying themselves into the Wangara on the other. The course given by Sultan Bello, and the information obtained by Major Denham, both pointed out a river coursing to the east, which is probably the branch followed by the Landers; for its termination in Lake Tchad had not even an air of probability; though it is not, on the other hand, at all improbable that other branches empty themselves into the Bight of Benin, by the rivers Formosa or Volta, according to information given to Captain Clapperton and Major Laing.

We had intended to embody some remarks upon the pretended journey of Caillié; but we find we have already occupied too much space in details necessary to make the geographical nature of the question well understood; and we shall content ourselves with remarking, that the discovery of the termination of the Quorra, or Niger, tends to throw a degree of improbability upon the narrative of that individual, which it will require much ingenuity to explain away. It is certain that the latitude given to Timbuctoo by the editor of those travels, and upon which sufficient ridicule has already been thrown in the Edinburgh Geographical Journal, may be considered as an error entirely of the editor's, who, by taking it upon himself, will relieve the burden of the mistake from the traveller, and thus lighten the weighty doubts which might in consequence bear upon the remainder of the details; for the situation of that city, as given by Jomard, is quite inconsistent with the situation it must be in, from the ascertained source, direction, and termination of the river. There can be no doubt but that a portion of the labours presented to the public as the travels of Caillié are founded upon valid documents, wherever obtained, and probably most of the errors are those of the editor. But though authorities can be found in support of the division of the Quorra into two branches; one of which, the Joliba, flows to the north-west, and the other in an almost opposite direction,—a fact which has no analogy in geography, and, what is better, no existence in nature; yet no authority can be found for placing Timbuctoo on a river flowing north from the Niger.

The details which will be given to us

by the results of this successful expedition will, then, not only be of assistance in allaying the existing condition of things with the knowledge of the ancients, but it will enable us to reduce to a few facts the many contradictory statements which have originated in the variety of the sources of information, and the individual and national rivalry which the interest of the question gave birth to among the geographers of the present day. It will also be of importance, as it was connected with a great question, as to the possibility of a large river traversing an extensive continent, or losing itself in a marsh or lake, or being buried in the extensive sands of the desert. By laying open the interior of Africa to us, it will increase our political strength and commercial advantages on those coasts;—it will enable us to put into practice an amelioration long contemplated by Mr. Barrow, in the choice of our settlements on those coasts;—it will place the greatest and most important vent of the barbarous and inhuman traffic of negroes in our possession; and it will enable us to diffuse the benefits of superior intelligence among an ignorant and suffering people.

Preparations are making for the publication of Messrs. Landers' interesting journey. It will be a perfect route; for John Lander's notes, happily preserved, supply the lacuna in his brother's journal, which was lost. In all the interior the travellers were treated with kindness, until they arrived within twelve or fifteen days of the coast; here the hostility they experienced from the natives, originated, no doubt, in their being all engaged in the slave-trade, and dreading the interference of Europeans for the prevention of that detestable traffic.

After penetrating overland to Boussa, from Badagry, they remained there some time, and then ascended the river, during the dry season, (for they left Boussa on the 23rd of June,) to Youri, which took them five days. Here they stayed about a month, and might readily have gone to Saccatoo and Timbuctoo, had their instructions permitted. But as their object was to ascertain the debouchement of the Niger into the sea, they only waited for its flow on the setting in of the rains, and again descended

to Youri in four days, and arrived, we believe, on the 2nd of August. The river, previously crowded, rather than studded, with islands, and with its channel so dried up that it might be crossed without a boat at several places, was now a wide sheet of current, uninterrupted by islands, ledges, or other obstacles, and admitting of free navigation. From Youri our countrymen embarked on their downward way in a boat and a canoe; hiring the inhabitants on the banks, as occasion required, to row them. They thus passed in safety to Kirree, a very considerable town, and, as it would seem, the centre mart of the slave-trade. Below this, it appears, there is no general government; every town has its own independent king; and the natives above Kirree were so well aware of the predatory and ferocious habits of these chieftains, that it was with some difficulty they could be prevailed upon to man the boats. Nor were their fears unfounded. John Lander had dropped down in the canoe, when he was assailed by a squadron of Eboe (not, as printed in our first accounts, Hibboo) boats, several of which ran against his small vessel, which the third shock sent to the bottom, with its stores, instruments, and journals. The native boats in these parts are large and powerful; some of them rowing forty or fifty oars. Richard Lander, following his brother, found him a prisoner to these savages, and was himself also taken, and both together carried back to Kirree. Fortunately for them, the King of Brassé, a territory lying almost at the mouth of the river, persuaded their captors to commit them to him, to be conveyed to the coast, and such price or ransom obtained for them as he could negotiate.

After the loss of their chronometers, &c. the observations were of necessity not so correct as before. We understand, however, that from Boussa to the sea the course of the river is almost due south. At Kirree, or Eboe, which is two days lower down, it was apparently six miles in breadth from bank to bank, within which it was hardly confined: the flood was higher than any year remembered by the natives. But it is an important fact, that the height of the waters during the ordinary wet season

would enable a steam-boat to ascend to Boussa! a prospect of prodigious consequence to the future commerce and civilization of Africa.

Funda, it seems, instead of being on the right bank of the river as you descend, and inland, as laid down in our maps, is on the left bank, and situated on the Shary, a considerable way above its junction with the Niger. The new map to be constructed on the Landers' observations has, we hear, been entrusted to the very able direction of Captain Becher, to whose talents and ability we naturally look for a great accession to our geographical knowledge in this respect.

The sides of the river are often clothed with thick jungle; other parts and the islands, when habitable, are rather populous. There can be little doubt that the streams which flow into the Bight of Benin, and also the old Calabar river, are portions of the delta formed by the Niger, as well as the branch to Biafra descended by our travellers. The tide flows up a good way. The *Brighton Herald* says, that Mr. Brewer, of the St. James's Street Library there, has an old map printed at Amsterdam, in which the Niger is distinctly laid down throughout its course to Biafra.

LOCAL ATTRACTION, &c.—THE LOSS OF H.M.S. THETIS.—In the notices that have appeared of the loss of the *Thetis*, it was conjectured to have arisen from an extraordinary current and dense fog. Mr. Barlow, however, as appears from a paper lately read before the Royal Society, is of a different opinion; and the facts urged by him are of such general interest, that we think it well to circulate them as extensively as possible.—He observes, that the errors arising from the deviation of the compass produced by the attraction of ships, were formerly much less considerable than at present, from the comparatively small quantity of iron existing in the vessel. The increase of this disturbing force in a modern ship of war is easily accounted for by the immense proportion of iron now employed in its construction; by the use of iron ballast and iron tanks, of iron knees, iron cables, and, above all, of iron capstans; besides various other articles made of the same material, forming altogether a very large and powerful magnetic mass. The di-

rection and intensity of the deflecting forces thus produced, vary in different latitudes, and on different sides of the equator. In H.M.S. *Gloucester*, which may be taken as an example, the deviation of the compass in the east and west points was found to be, in the British Channel, $9^{\circ} 30'$: so that, after running ten miles, the vessel would be more than a mile and a half to the southward of her reckoning; and so on, in proportion as the distances increased. Now, on leaving Rio Janeiro, the *Thetis* directed her course S.E.; but, the next day, thinking they were clear of land, they tacked, and were sailing at the rate of nine knots, when the first intimation they had of being near land, was the striking of the jib-boom against a high perpendicular cliff. Mr. Barlow is of opinion that the deviation of the compass arising from the attraction of the vessel, was exactly of the kind which was likely to occasion this great mistake in the ship's reckoning; for the distance run by the *Thetis* being about eighty miles, if the local attraction of the vessel had been equal to that of the *Gloucester*, she would have passed five miles nearer to Cape Frio than her reckoning—an error quite sufficient to account for the fatal catastrophe.

EXTRAORDINARY CASE OF SHIPWRECK.—We extract the following case and *cause* of shipwreck, as narrated by the Captain of the unfortunate vessel, from the *Journal of Voyages and Travels*, by the Rev. Daniel Tyerman and George Bennet, Esq.; compiled from Original Documents, and edited by James Montgomery.

“My first shipwreck was in open sea, on the 20th November 1820, near the equator, about 118° W. long. The vessel, a South Sea whaler, was called the *Essex*. On that day, as we were on the look-out for sperm whales, and had actually struck two, which the boats' crews were following to secure, I perceived a very large one—it might be eighty or ninety feet long—rushing with great swiftness through the water, right towards the ship. We hoped that she would turn aside, and dive under, when she perceived such a baulk in her way. But no! the animal came full force against our stern-port: had any quarter less firm been struck, the vessel must have been

burst; as it was, every plank and timber trembled throughout her whole bulk.

"The whale, as though hurt by a severe and unexpected concussion, shook its enormous head, and sheered off to so considerable a distance, that for some time we had lost sight of her from the starboard quarter; of which we were very glad, hoping that the worst was over. Nearly an hour afterwards, we saw the same fish—we had no doubt of this, from her size, and the direction in which she came—making again towards us. We were at once aware of our danger, but escape was impossible. She dashed her head this time against the ship's side, and so broke it in, that the vessel filled rapidly, and soon became water-logged. At the second shock, expecting her to go down, we lowered our three boats with the utmost expedition, and all hands, twenty in the whole, got into them—seven, and seven, and six. In a little while, as she did not sink, we ventured on board again, and, by scuttling the deck, were enabled to get out some biscuit, beef, water, rum, two sextants, a quadrant, and three compasses. These, together with some rigging, a few muskets, powder, &c. we brought away; and, dividing the stores among our three small crews, rigged the boats as well as we could; there being a compass for each, and a sextant for two, and a quadrant for one, but neither sextant nor quadrant for the third. Then, instead of pushing away for some port, so amazed and bewildered were we, that we continued sitting in our places gazing upon the ship, as though she had been an object of the tenderest affection. Our eyes could not leave her, till, at the end of many hours, she gave a slight reel, then down she sank. No words can tell our feelings. We looked at each other—we looked at the place where she had so lately been afloat—and we did not cease to look, till the terrible conviction of our abandoned and perilous situation roused us to exertion, if deliverance were yet possible.

"We now consulted about the course which it might be best to take—westward to India, eastward to South America, or south-westward to the Society Isles. We knew that we were at no great distance from Tahiti, but were so ignorant of the state and temper of the inhabitants, that we feared we should be de-

voured by cannibals, if we cast ourselves on their mercy. It was determined, therefore, to make for South America, which we computed to be more than two thousand miles distant. Accordingly we steered eastward, and, though for several days harassed with squalls, we contrived to keep together. It was not long before we found that one of the boats had started a plank, which was no wonder, for whale-boats are all clinker-built, and very slight, being made of half-inch plank only, before planing. To remove this alarming defect we all turned to, and, having emptied the damaged boat into the two others, we raised her side as well as we could, and succeeded in restoring the plank at the bottom. Through this accident, some of our biscuit had become injured by the salt-water. This was equally divided among the several boats' crews. Food and water, meanwhile, with our utmost economy, rapidly failed. Our strength was exhausted, not by abstinence only, but by the labours which we were obliged to employ to keep our little vessels afloat, amidst the storms which repeatedly assailed us. One night we were parted in rough weather; but though the next day we fell in with one of our companion-boats, we never saw or heard any more of the other, which probably perished at sea, being without either sextant or quadrant.

"When we were reduced to the last pinch, and out of every thing, having been more than three weeks abroad, we were cheered with the sight of a low, uninhabited island, which we reached in hope, but were bitterly disappointed. There were some barren bushes, and many rocks on this forlorn spot.* The only provisions that we could procure, were a few birds and their eggs; this supply was soon reduced: the sea-fowls appeared to have been frightened away, and their nests were left empty after we had once or twice plundered them.

* "Their sufferings from want of water were the most severe, their only supply being from what remained in holes among the rocks after the showers which fell at intervals; and sometimes they were five or six days without any; on these occasions they were compelled to suck the blood of the birds they caught.

What distressed us most, was the utter want of fresh water; we could not find a drop anywhere, till, at the extreme verge of ebb-tide, a small spring was discovered in the sand; but even that was too scanty to afford us sufficient to quench our thirst before it was covered by the waves at their turn.

"There being no prospect but that of starvation here, we determined to put to sea again. Three of our comrades, however, chose to remain, and we pledged ourselves to send a vessel to bring them off, if we ourselves should ever escape to a Christian port. With a very small morsel of biscuit for each, and a little water, we again ventured out on the wide ocean. In the course of a few days our provisions were consumed. Two men died; we had no other alternative than to live upon their remains. These we roasted to dryness by means of fires kindled on the ballast-sand at the bottom of the boats. When this supply was spent, what could we do? We looked at each other with horrid thoughts in our minds, but we held our tongues. I am sure that we loved one another as brothers all the time; and yet our looks told plainly what must be done. We cast lots, and the fatal one fell on my poor cabin-boy. I started forward instantly, and cried out, 'My lad, my lad, if you don't like your lot, I'll shoot the first man that touches you.' The poor emaciated boy hesitated a moment or two; then, quietly laying his head down upon the gunnel of the boat, he said, '*I like it as well as any other.*' He was soon dispatched, and nothing of him left. I think, then, another man died, and him, too, we ate. But I can tell you no more—my head is on fire at the recollection—I hardly know what I say. I forgot to say that we had parted company with the second boat before now. After some more days of horror and despair, when some were lying down at the bottom of the boat not able to rise, and scarcely one of us could move a limb, a vessel hove in sight. We were taken on board, and treated with extreme kindness. The second lost boat was also picked up at sea, and the survivors saved. A ship afterwards sailed in search of our companions on the desolate island, and brought them away."

"Captain Pollard closed his dreary

narrative with saying, in a tone of despondency never to be forgotten by him who heard it—"After a time I found my way to the United States, to which I belonged, and got another ship. That, too, I have lost by a second wreck off the Sandwich Islands, and I am utterly ruined. No owner will ever trust me with a whaler again, for all will say I am an *unlucky* man." ii. 24—29.

ARRIVALS, SAILINGS, AND INCIDENTS IN THE FLEET.

Portsmouth.—April 26th. Arrived the Cracker cutter from Jersey.

May 22nd. Arrived the *Savage*, 10, Lord Edward Russel, from *Lisbon*.

May 23rd. Arrived the *Caledonia*, 120, Capt. Curzon, from *Plymouth*, to join the squadron at *Spithead*.

May 25th. Arrived the *Prince Regent*, 120, Capt. J. W. D. Dundas, from the *Eastward*, to join the squadron at *Spithead*; sailed the *Savage*, 10, Lord Edward Russel, for *Cork*, and the *Starling* cutter for *Plymouth*.

May 27th. Arrived the *Alban* steam-vessel from *Cork*; sailed the *Pike* schooner, under the command of Capt. Vidall, for *Plymouth*; to proceed thence to survey the *Hebrides*, and the contiguous coast of *Scotland*.

May 28th. Arrived the *Samarang*, 28, Capt. W. F. Martin, from *Leith*.

May 29th. Arrived the *Emerald* cutter, from *Cork*, and the *Starling* tender, from a cruise.

May 31st. Arrived the *Sylvia* cutter, from *Jersey*.

June 3rd. Arrived the *Briton*, 46, Capt. J. Markland, C.B., and the *Childers*, 18, Commander Deans, from *Lisbon*.

June 4th. Arrived the *Columbia*, and *Confiance* steamers; the latter sailed for *Plymouth*.

June 5th. Arrived the *Revenge*, 76, Capt. J. Hillyar, C.B. from *Plymouth*.

June 6th. Arrived the *Alfred*, 50, Capt. Robert Maunsell, from *Chatham*.

June 9th. Arrived the *Barham*, 50, Capt. H. Pigot, from *Woolwich*.

June 12th. Arrived the *Wasp*, Commander Popham, from *Malta* and *Gibraltar*.

June 13th. Arrived the *Volage*, 28, Capt. the Right Hon. Lord Colchester, from *Cherbourg*.

June 14th. Sailed the *Starling* and

Linnet cutters to the eastward for seamen.

June 15th. Arrived the Winchester, 52, Capt. the Right Hon. Lord William Paget, from Bermuda; the Talavera, 74, Capt. Colby, from the eastward, to form part of the squadron under the command of Sir E. Codrington; the Cracker cutter from Jersey, and Snipe tender with volunteers for the Asia.

June 17th. Arrived the Vigilant ketch from Plymouth, and Sylvia cutter from Jersey.

June 20th. Arrived the Medina, 20, Commander Castles, (acting,) from the Coast of Africa.

June 21st. Sailed the Childers, 10, Commander Robert Deans, for South America.

June 23rd. Sailed the Medina, Commander Castles, for Chatham, to be paid off.

At Spithead—Caledonia, Prince Regent, Asia, Donegal, Wellesley, Talavera, Revenge, Alfred, Barham, Briton, Curacoa, Volage, Pearl, Brisk, Vigilant.

In the Harbour—Spartiate, Royal George, Winchester, Samarang, Rattlesnake, Tweed, Victor, Recruit, Charybdis, and Columba and Alban steamers.

Plymouth.—May 21st. Arrived the African steamer, Lieut. J. Harvey, from the Mediterranean, last from Falmouth. She left Corfu on the 29th of April, Malta the 4th of May, and Gibraltar the 14th of May. Sailed H. M. ship Caledonia, 120, Capt. Curzon, for Portsmouth.

May 22nd. Arrived the Harpy, 10, Commander J. P. D. Larcom, from the West Indies, having left Jamaica on the 4th of April, and the Havannah on the 18th.

May 24th. Arrived the Semiramis, Capt. Tucker, (acting,) from Cork, in tow of the Alban steamer, Lieut. Davis, to be paid off; also the Pallas, 42, Capt. Manly H. Dixon, from Portsmouth, on her way to Bermuda.

May 26th. Sailed the Alban and African, Government steamers, for Portsmouth and Woolwich.

May 27th. Arrived the Pike schooner, Lieut. Wigley, and Starling tender, from Portsmouth.

May 31st. Arrived the Viper, new schooner, from Milford yard. Sailed the Pallas, 42, Capt. M. Dixon, with supplies for the homeward bound merchantmen, detained in the chops of the Channel by the late prevailing easterly winds; also, the Pike schooner, 12, Capt. A. T. Vidal,

to survey the north-western coast of Ireland and the Hebrides.

June 1st. Arrived the Windsor Castle, 76, Capt. the Hon. D. P. Bouverie, from Lisbon.

June 2nd. Arrived the Carron steam-vessel, Lieut. Lapidge, in five days from Lisbon.

June 4th. Sailed the Revenge, 76, Capt. Hillyer, for Spithead.

June 5th. Arrived the Pallas, 42, Capt. M. H. Dixon, from her cruise to the westward, and the Constance and Alban steamers from Portsmouth; the latter proceeded to Cardiff on the 6th, with nearly the whole of the 98th depot, as a reinforcement to the military in that disturbed district.

June 7th. Arrived the Vigilant ketch, Lieut. Loney, from Lisbon.

Remaining in Hamoaze—Foudroyant, Dublin, Stag, Pylades, Royalist, Plover packet, Echo, Carron, and African steam-vessels, and Industry Naval transport.

In the Sound—Pallas, and Morley freighted ship, and Kyalm and Lionelle Russians.

Foreign.—H. M. ship Britannia, 120, Capt. W. J. H. Johnstone, with the flag of Sir Pulteney Malcolm; Ganges, 84, Capt. G. Burdett; Kent, 78, Capt. S. Pym; left Malta on the 2nd of May on a cruise. The Melville, 74, Capt. C. W. Nesham, was gone to Palermo. The rest of the squadron were distributed as follow on the 4th of May: In the Archipelago—Madagascar, 46, Capt. E. Lyons; Alligator, 28, Capt. Sir C. Yorke; Raleigh, 18, Commander A. Hawkins; Pelican, 18, Commander J. Gape; Ferret, 10, Commander E. Wodehouse; Mastiff, 6, Lieut.-Commander J. Wolfe; and Meteor, 8, Commander R. Copeland. At Tripoli—Scylla, 18, Commander J. Hindmarsh. At Corfu—Rainbow, Capt. Sir J. Franklin; and Procris, 10, Commander W. Griffiths (acting). At Constantinople—Hind cutter.

The Sapphire arrived at Madeira from Portsmouth the 17th of April, and sailed the 19th for Bermuda. The Acteon sailed on the 12th of May, from Gibraltar for Tangiers. The Wasp arrived at Gibraltar on the same day, from Malta; and the Meteor steamer from Falmouth on the 13th. The Scylla arrived at Malta on the 4th of May, from Tripoli. The Blanche arrived at Jamaica from Nassau 4th of April. Nightingale sailed from Jamaica for Honduras, and Winchester for Montego Bay, 5th of April. Falcon sailed from

Jamaica for St. Jago de Cuba 6th of April; and Cordelia for a cruise 8th of April. Reynard arrived at Rio Janeiro from Falmouth 11th of March, and sailed 14th for Buenos Ayres. Comet was at Sydney, New South Wales, 18th of December. Zebra sailed from Madras on a cruise 18th of January.

The Seringapatam was at Valparaiso 23rd of January. Barracouta arrived at Barbadoes from Falmouth 12th of April, and sailed for Jamaica. Columbine sailed from Barbadoes 15th of April. Success has been repaired at Freemantle, Western Australia, and sailed 15th of January for India.

The Ranger arrived at Bermuda from Jamaica 11th of April, Gannet from England 15th, and North Star from England 21st. Fusileer arrived at Mauritius from a cruise 28th of January. Speedwell arrived at Port au Prince 2nd of April. Clio sailed from Buenos Ayres for Monte Video and Valparaiso 17th of January. Briseis arrived at Halifax from Falmouth 10th of May. Frolic arrived at Monte Video from Falmouth and Rio 10th of March. Nightingale arrived at Honduras from Falmouth 11th of April. Hyacinth arrived at Jamaica from Carthagenia 11th of April; Rose, from Santa Martha 14th; Kangaroo, from a cruise 18th; and Falcon, from St. Jago de Cuba, 19th.

The Falcon, Commander Currie, sailed from Halifax on the 18th of May, to convey money to Bermuda; and on the 19th the Sapphire, Capt. Hon. W. Wellesey, sailed from Bermuda for Halifax, to protect the fisheries in the Bay of Fundy; and the same day the Ranger, Capt. W. Walpole, for Halifax, to protect the fisheries in the Gulf of St. Lawrence. The Gannet, Commander Sweeney, sailed from Bermuda on the 25th of May.

The Racehorse, 18, Commander Oldrey, sailed on the 22nd of April; and the Columbine, 18, Commander Gabriel, on the following day from Antigua, for Porto Rico, to cruise for pirates, some having been seen hovering about that coast.

The Ramillies, 74, Creole, 42, Iphigenia, 42, Dartmouth, 42, and Hussar, 46, are ordered to be fitted at Chatham as temporary lazarettes, in consequence of the recent quarantine order.

The Pylades, 18, has been paid off at Plymouth, and re-commissioned by Commander Blanckley.

The Samarang, Capt. W. F. Martin, has been paid off at Portsmouth, and re-commissioned.

The Hyperion, Capt. Mingaye, has been paid off, and laid up in ordinary at Portsmouth.

The Blonde, 46, Capt. Sir Thomas Pasley, Bart. has been paid off into ordinary at Portsmouth.

Orders have been issued, that ships directed to be paid off, and fit for re-commissioning, are not to be stripped, nor any thing removed, but to be kept in readiness to proceed to sea the day after being paid off, if required.

The Chanticleer, surveying vessel, Commander Fitzroy, at Woolwich, is expected to return to the southern part of South America, to complete the survey of the late Commander Foster.

The Windsor Castle, 74, was paid off into ordinary at Plymouth on the 20th of June.

The Royalist, 10, was commissioned on the 20th of June at Plymouth, by Lieut. Williams.

The Wasp, 18, Commander Popham, was paid off at Portsmouth on the 20th of June.

An order has been issued to assemble a Court Martial, on board the Caledonia, (bearing the flag of Vice-Admiral Sir Edward Codrington, G.C.B.) at Spithead, to try Capt. the Right Hon. Lord William Paget, for having ordered Capt. Ayscough, late Commissioner at Bermuda, to be excluded from the cabin allotted to him on board His Majesty's ship Winchester, by Vice-Admiral Colpoys, Commander-in-Chief on the Bermuda Station, and for disrespectful and unofficer-like behaviour, during the passage to England, in that ship.

PROMOTIONS & APPOINTMENTS.

NAVY.

PROMOTIONS.

CAPTAIN—Sir Thomas Pasley, Bart.

COMMANDERS—W. Shepherd, Frederick Rogers.

LIEUTENANTS—George Williams, Hintzel.

SURGEON—W. Bothwell, of the Harpy.

APPOINTMENTS.

CAPTAINS—Charles H. Paget, to the Samarang; the Right Hon. Lord W. Paget, from the North Star, to the Winchester; the Hon. G. R. W. Trefesis, to the North Star.

COMMANDERS—Jackson, from the Hya-

cinth to the Magnificent, vice Gill, invalided; — Oldrey, to the Hyacinth, vice Jackson; — Stewart, of the Winchester, to the Icarus, vice Corrie, to the Winchester; Allan Bertram, from the Revenge to the Tweed; Thomas Talbot, to the Procris; James Brasier (Supernumerary Commander) to the Wellesley; Osborne Foley, from the Asia to the Spartiate; R. Oliver (b), to the Asia; — Drury, — Hutchinson, and — Cole, to the Coast Guard Service; — Higgs, to the Revenge; — Webb, of the Medina, to the acting command of the Athol, vice Gordon, invalided; — Fitzroy, to the Chanticleer; Alfred Luckraft, to the Revenge.

LIEUTENANTS—R. Ratsey, to the Ordinary at Sheerness; G. Decourdoux, to the Ordinary at Portsmouth; E. C. Miller, to the Victor; Richard Robinson and James U. Baker, both re-appointed to the Pylades; Joseph Bird, to the Galatea; A. Buchanan, to command the Pluto steam-vessel; — Shortland, from the Kangaroo to the Skipjack, vice Roche, invalided; — Hookey, to the Kangaroo; — Allen, from the Ranger to the Falcon; — Hope, from the Falcon to the Hyacinth; — Bagot, from the Icarus to the Sparrowhawk; Thomas Lyell and G. Kennedy, to the Tweed; Horatio Blair, of the Savage, to the Pallas, vice Trevanion; — John Fletcher, Flag-Lieutenant to Rear-Admiral Parker; J. J. Sullivan, to command the Plumper gun-brig; R. Yorke, to the Donegal, vice Crawford; N. Dalway, C. Johnson, and J. Hains, late Supernumerary Lieutenant of the Talavera, to the Preventive Service; G. Green, to the Revenue cruiser Scout, vice Carter; I. Roberts, to the revenue cruiser Hornet, vice Beatty; W. B. McClintock, William Smyth, and J. C. Fullerton, to the Samarang; William Shepherd, to the Rattlesnake; J. Garrett, to the Racehorse, vice Reigner; J. Reigner, to the Mersey, vice Garrett; William Crooke, to the Ranger, vice Allen; J. J. Allen, to the Falcon, vice Crooke; N. Ratsey, of the Portsmouth Ordinary, and G. Decourdoux, of the Sheerness Ordinary, have been permitted to exchange duties; J. Gutzmer, from the Harpy to the Magnificent, vice Hookey; St. Ledger Aldworth, from the Ranger to the Mersey, vice Collins; J. A. Abbott, from the Blossom to the Ranger, vice Aldworth; T. Hope, from the Falcon, to the Hyacinth, vice Dawson; J. W. Aldridge, to the Rattlesnake; R. H. Elliot, to the Briton; Horatio James, to the Viper; R. N. Williams, to the Royalist; S. Jackson, R. Taylor, E. Wylde, J. Lester, W. Finch, J. Burnett, R. Poole, C. Antride, Chapman Wise, R. Kelly, R. L. Stephens, F. Purchas, A. Maan, W. Congdon, P. Ralfe, and W. Alfred, to the Coast Guard Service; Robert A. Elliot, to the Briton, vice Codrington, appointed Flag-Lieutenant to Sir E. Codrington; F. Gray, to the Ordinary at Chatham; — Castles, to the acting command of the Medina; — Servante, to the Athol; — Martin, to the Dryad; — Ramsey, to the Black Joke; J. Rainier, from the Mersey to the Hyacinth.

SURGEONS—J. West, to the Victor; — Price, to the Tweed; Launcelot Armstrong, to the Hospital at the Cape of Good Hope, vice

Swayne; Sir J. A. Anderson, M.D. from the Royal Sovereign Yacht to the Royal Charlotte Yacht; — Prior, from the Royal Charlotte Yacht to the Royal Sovereign Yacht; — Moxey, to the Samarang; H. Baillie, to the Astrea; John Greenish, to the Royal George Yacht; — Fisher, M.D. to the Medina.

ASSISTANT-SURGEONS—Henry Williams, of the Manly to the Asia; T. S. Taylor, to the Prince Regent; T. F. Cottram, to the Pike; John Rodgers, to the Charybdis; James Bankeer, to the Spartiate; — Wilkes, to the Samarang; W. B. Marshall, to the Victor; N. Robinson, to the Pluto Steam-Vessel; — Cunningham, to the Favorite; A. Wiseman, to the Plumper; T. Neilson, to the Conflict; J. Andrews, to the Tweed.

MASTER—J. B. Tucker, to the Tweed.

PURSERS—T. McKnight, to the Tweed; — Lord, to the Sparrowhawk, vice Beale, invalided; William Drake, to the Pylades; Francis Lean, to the Pearl; J. Melvin, to the Samarang; H. Louth, to the Victor.

CHAPLAINS—Rev. John Buchanan, to the Dryad; Rev. M. Beebee, to the Revenge, vice Hardy; Rev. W. Johnson, to the Stag; Rev. E. Pettman, to the Dublin.

ROYAL MARINES.

PROMOTIONS.

Brevet Lieut.-Col. Torrens, M.P. to be Major at Chatham, vice Snowe, dec.

Brevet Major Wilkinson, to be Captain at Plymouth, vice Torrens.

First-Lieut. Nicholas, to be Captain at Portsmouth, vice Wilkinson; First-Lieut. J. E. Jones, to be Capt. vice O'Neil, who retires on full pay.

Second-Lieut. Wright, R. M. A. to be First-Lieut.

Second-Lieut. J. Woods, to be First-Lieut.

Second-Lieut. E. W. Churchill, to be First-Lieut.

To be Second-Lieuts.:—Mr. Byng Payne; Mr. Maltby; Mr. Henry Crespin, R. M. A.; Mr. Alexander Stevenson, R. M. A. vice Wright, promoted; Mr. J. D. Lamont.

APPOINTMENTS.

Capt. Hughes, to the Winchester.

ARMY.

WAR OFFICE, MAY 31.

1st or Gren. Regt. Foot Gds.—James Walker Drummond, gent. to be Ens. and Lieut. by p. vice Hope, prom.

4th Regt. Foot.—Ens. William Brabazon Ponsonby, to be Lieut. by p. vice Alloway, who ret.; Robert Henry Monypenny, gent. to be Ens. by p. vice Ponsonby.

9th Foot.—Lieut.-Colonel Holman Custance, from h. p. to be Lieut.-Colonel, vice Jeremiah Taylor, who exc. rec. diff.

12th Ditto.—John Hyndman Cameron, gent. to be Ens. by p. vice Villebois, who rets.

40th Ditto.—Ens. Thomas Sidney Powell, to be

Lieut. by p. vice Low, who rets.; James Frederick Elton, gent. to be Ens. by p. vice Powell.

55th Ditto.—Ens. George Abercrombie Robertson, to be Lieut. without p. vice Trydell, dec.; Henry Bayly, gent. to be Ens. vice Robertson.

69th Ditto.—Serjeant-Major Newel, from 90th Foot, to be Adjt. with the rank of Ens. vice Bolton, prom.

90th Ditto.—Thomas Webb, gent. to be Ens. by p. vice Anson, who rets.

98th Ditto.—Ens. John Henry Armstrong, to be Lieut. by p. vice Freebairn, who ret.; Charles Stretton, gent. to be Ens. by p. vice Armstrong.

DOWNING-STREET, JUNE 6.

The King has been pleased to nominate and appoint Admiral the Hon. Sir Robert Stopford, Knight Commander of the Most Honourable Military Order of the Bath, to be a Knight Grand Cross of the said Most Honourable Military Order, vice Admiral the Earl of Northesk, deceased.

His Majesty has farther been pleased to nominate and appoint Admiral Sir Benjamin Hallowell Carew, Knight Commander of the Most Honourable Military Order of the Bath, to be a Knight Grand Cross of the said Most Honourable Military Order.

WAR OFFICE, JUNE 7.

1st Regt. of Life Gds.—John Richard Blagden Hale, gent. to be Cor. and Sub-Lieut. by p. vice Bayntun, prom.

6th Regt. Dr. Gds.—Cor. Edmund Lally, from h. p. 4th Dr. Gds. to be Cor. vice Banks, dec.

2nd Regt. Foot.—Lieut. George Dalhousie Jolliffe Raitt, to be Capt. by p. vice Graham, prom.; Ens. Thomas Gravatt, to be Lieut. by p. vice Raitt; Henry Robert Harrington Cary Elwes, gent. to be Ens. by p. vice Gravatt.

4th Foot.—Staff-Assist. Surg. James Henderson Rolland, to be Assist.-Surg.

30th Ditto.—Major Harry Smith Ormond, from 49th Foot, to be Major, vice Light, who rets.; Lieut. Harvey Vachell, from 46th Foot, to be Lieut. vice Magee, app. to 45th Foot.

49th Ditto.—Major Henry Crossdale, from h. p. unatt. to be Major, vice Ormond, app. to 30th Foot.

67th Ditto.—Lieut. John William Donelan, to be Capt. without p. vice Logan, dec.; Ens. Thomas Aubin, to be Lieut. vice Donelan; Henry Montagu Smyth, gent. to be Ens. vice Aubin.

58th Ditto.—Sec.-Lieut. R. E. Wilmot Horton, from Ceylon Regt. to be Ens. vice Mackenzie, app. to 68th Foot.

68th Ditto.—Ens. William Henry Gillman, to be Lieut. without p. vice Ring, dec.; Ens. Alexander Douglas Mackenzie, from 58th Foot, to be Ens. vice Gillman.

67th Ditto.—Lieut. John Du Vernet, from 14th Foot, to be Lieut. vice Charles Greaves, who ret. upon h. p. 14th Foot.

95th Ditto.—Capt. Henry Churchill Tathwell, from h. p. unatt. to be Capt. vice Robert Cumming Hamilton Gordon, who exc. rec. diff.

96th Ditto.—Lieut. Henry Nixon, from 35th Foot, to be Lieut. vice Dalgety, whose app. has not taken place.

Rifle Brigade.—Lieut. James Saumarez Came-

ron, to be Capt. by p. vice Ross, prom.; Sec.-Lieut. Richard Snowden Smith, to be First-Lieut. by p. vice Cameron; William Henry Frankland, gent. to be Sec.-Lieut. by p. vice Smith.

Unattached.—To be Majors of Infantry by p.—Capt. James Kerr Ross, from Rifle Brigade; Capt. George Graham, from 2nd Foot.

To be Lieut. by purchase.—Cor. Samuel Adam Bayntun, from 1st Life Guards.

Brevet.—Lieut.-Gen. Sir Edward Barnes, G.C.B. to have the rank of General in the East Indies only; Garrison Serjeant-Major H. J. Denny, Acting Adjt. and Riding-master to the Cavalry Depot at Maidstone, to have the rank of Cornet while so employed.

Hospital Staff.—Assist.-Surg. William Wallace, M. D. from 80th Foot, to be Staff-Assist.-Surg. vice Rolland, app. to 4th Foot.

Memorandum.—The undermentioned officers have been allowed to retire from the service, by the sale of unattached commissions:—Major George Ford, h. p. unatt.; Lieut. Charles Pratt Wyatt, h. p. 3rd West India Regt.

Memorandum.—The half-pay of the undermentioned officers has been cancelled from the 7th instant inclusive, upon their receiving a commutation for their commissions, viz.:—Surg. Robert Alexander Chermiside, h. p. Hospital Staff; Assist. Surg. Thomas Ward Jeston's h. p. 36th Foot; Ens. and Lieut. Richard Beamish, h. p. Coldstrm. Foot Gds.; Assist.-Surg. Thomas Charlton Speer, h. p. 56th Foot; Ens. John Vassall, h. p. 50th Foot; Lieut. Cornelius Hogan, h. p. 21st Light Drs.; Lieut. Patrick King Nolan, h. p. Canadian Fencible Inf.; Lieut. George Matcham Tarleton, h. p. 3rd Gar. Bat.; Ens. Duncan Macdonald, h. p. 14th Foot; Lieut. Edward Stephen George Marlay, ret. full p. 2nd European Gar. Comp.; Hospital-Assist. John Smith, h. p.

ST. JAMES'S PALACE, JUNE 8.

The King was this day pleased to confer the honour of Knighthood upon Colonel Stephen Remnant Chapman, of the Royal Engineers, Governor and Commander-in-Chief of the Bermudas.

WHITEHALL, JUNE 14.

The King has been pleased to direct letters patent to be passed under the Great Seal of the United Kingdom, granting unto Admiral Sir Thomas Foley, G.C.B. the offices or places of Rear-Admiral of the United Kingdom of Great Britain and Ireland, and of the Admiralty thereof, and also of Rear Admiral of the Navies and Seas of the said United Kingdom, in the room of the Earl of Northesk, dec.

WAR OFFICE, JUNE 14.

10th Regt. Light Dra.—Cornet Henry Frederick Bonham, to be Lieut. by p. vice Pyrke, who ret.; George Augustus Frederic Quentin, gent. to be Cornet, by p. vice Bonham.

1st or Gren. Regt. Foot Gds.—Ens. and Lieut. Charles William Ridley, to be Lieut. and Capt. by p. vice Jodrell, who ret.; Ens. Robert Blenkinsopp Coulson, from 98th Foot, to be Ens. and Lieut. by p. vice Ridley.

4th Regt. Foot.—Arthur Nicholson, gent. to be Ens. by p. vice Stanhope, who ret.

70th Ditto.—Henry Charles Whalley, gent. to be Ens. by p. vice Dyott, prom.

72nd Ditto.—Capt. John Watts, from h. p. unatt. to be Capt. vice Donald M'Lean, who exc. rec. the diff.

98th Ditto.—John Rainier, gent. to be Ens. by p. vice Coulson, app. to the 1st or Gren. Foot Gds.

Ceylon Rifle Regt.—Richard Newenham, gent. to be Sec. Lieut. by p. vice Horton, app. to 58th Foot.

Unattached.—Ens. Richard Dyott, from 70th Foot, to be Lieut. of Inf. by p.

Memorandum.—Lieut. William Sibbald, h. p. 1st Foot, has been allowed to retire from the service, by the sale of an unatt. com.

The h. p. of Lieut. Patrick King Nolan, of the Canadian Fenc. was cancelled from the 13th of May 1831, inclusive, and not from the 7th of June 1831, as stated in the Gazette of the latter date.

ST. JAMES'S-PALACE, JUNE 15.

The King was this day pleased to invest Vice-Admiral Sir Charles Ekins with the ensigns of a Knight Commander of the Most Honourable Military Order of the Bath.

By command of the Sovereign, Sir Charles Ekins was conducted, with the usual reverences, to His Majesty, preceded by Sir George Nayler (the officer of Arms attendant upon the Knights Commanders), bearing upon a crimson velvet cushion the star, riband, and badge of the second class of the Order.

The sword of state being thereupon delivered to His Majesty, the Vice-Admiral kneeling, was knighted therewith, after which he had the honour to kiss His Majesty's hand. Then Sir George Nayler, on his knee, presenting to the Sovereign the riband and badge of a Knight Commander, the King was pleased to invest Sir Charles Ekins with the same.

The Vice-Admiral having again had the honour to kiss the Sovereign's hand, and having received from His Majesty the star of a Knight Commander, retired.

DOWNING-STREET, JUNE 15.

The King has been pleased to appoint Major-Gen. William Nicolay to be Governor and Commander-in-Chief of St. Christopher, Nevis, and the Virgin Islands.

WAR OFFICE, JUNE 21.

4th Regt. Light Drs.—Cornet Bryan Higgins Blake, to be Lieut. by p. vice Gibson, prom.; Justinian Vernon, gent. to be Cornet, by p. vice Pearson, who ret.

9th Ditto.—Capt. Alfred Lord Harley, from h. p. to be Capt. vice William E. FitzMaurice, who exc. rec. the diff.

4th Regt. Foot.—Lieut. Charles Rumley, from h. p. of the 22nd Regt. to be Lieut. vice Ponsoby, app. to the 7th Regt.

7th Ditto.—Lieut. William Brabazon Ponsoby, from the 4th Regt. to be Lieut. vice Pitcairn, app. to 92nd Regt.

46th Ditto.—Capt. Thomas Thompson, to be Major, by p. vice Nairn, who ret.; Lieut. James Taylor, to be Capt. by p. vice Thompson; Ens. William Thomas Bremner, to be Lieut. by p. vice Taylor; Francis Lucas, gent. to be Ens. by p. vice Bremner.

47th Ditto.—Brevet Lieut.-Col. James Jenkin, from the h. p. to be Major, vice Fade Heatley, who exc.

53rd Ditto.—Lieut. Richard Dyott, from the h. p. to be Lieut. vice Edward Browne, who exc. rec. the diff.

69th Ditto.—Capt. Richard Wheeler Hooper, from the h. p. of the 3rd Dr. Gds. to be Capt. vice John O'Meara, who exc.; Gent. Cadet Charles James Coote, from the Rl. Ml. Col. to be Ens. by p. vice Hankey, prom.

72nd Ditto.—Lieut. William Henry Robinson, to be Capt. by p. vice Watts, who ret.; Ens. Charles William Meadows Payne, to be Lieut. by p. vice Robinson; Alfred Harris, gent. to be Ens. by p. vice Payne.

85th Ditto.—Lieut. Hon. Anthony Ashley Cooper, to be Capt. by p. vice Wilmot, prom.; Ens. Augustus Coryton, to be Lieut. by p. vice Cooper; Arthur Robert Rose, gent. to be Ens. by p. vice Coryton.

98th Ditto.—Charles Horatius Kennedy, gent. to be Ens. by p. vice Stretton, whose app. has not taken place.

Rifle Brigade.—Major-Gen. Sir George Ridout Bingham, K.C.B. to be Colonel Commandant of a Bat. vice Lieut.-Gen. Sir Thomas Sidney Beckwith, dec.; Lieut. William Sullivan, to be Capt. by p. vice Kincaid, who ret.; Sec.-Lieut. Edward Holt Glegg, to be First-Lieut. by p. vice Sullivan; Algernon William Billingham Greville, gent. to be Sec.-Lieut. by p. vice Glegg.

Unattached.—To be Major, without p.—Brevet-Major Haddon Smith, from the Ceylon Rifle Regt.

To be Major, by p.—Capt. Eardley Wilmot, from the 85th Regt.

Staff.—Major Andrew Leith Hay, on the h. p. of the 96th Regt. to be Dep.-Adjt.-Gen. to the Forces serving in the Windward and Leeward Islands (with the rank of Lieut.-Colonel in the army), vice Craig, who res.

Memoranda.—The Christian names of Lieut.-Colonel Barnard, of the 1st or Gren. Regt. Foot Gds. are Henry William, and not William Henry.

The Christian names of Ens. Monypenny, of the 4th Regt. are Robert Honeywood, and not Robert Henry.

Major John Spring Hamilton, h. p. unatt. has been allowed to retire from the service, by the sale of an unatt. com.

The h. p. of the under-mentioned officers has been cancelled from the 21st of June 1831, inclusive, upon their receiving a commuted allowance for their commissions:—

Lieut. David Frederick de Bachellé, h. p. 8th Line Bat. King's German Legion; Assist.-Surg. John Richard Elmore, h. p. 5th Dr. Gds.; Lieut. Henry Peyton, h. p. unatt.

STATIONS OF THE ARMY ON THE 1ST OF JULY, 1831.

AND REFERENCE TO THE FOREIGN SERVICE OF REGIMENTS.

Regiments and Corps.	Stations of Service Companies or Troops.	Stations of Reserve Companies.	Year of Going on Foreign Service.	Year of Returning from Foreign Service.	Whence Returned.	Agents.
1st Life-gds.	Hyde Park	.	.	1816	France	Collyer
2d do.	Windsor	.	.	1816	Ditto	Greenwood
Rl. Horse-gds.	Regent's Park	.	.	1816	Ditto	Greenwood
1st Drag.-gds.	Cahir	.	.	1816	Ditto	Armit
2d do	Leeds	.	.	1818	Ditto	Greenwood
3d do	Bristol	.	.	1814	Spain	Greenwood
4th do	Glasgow	.	.	1813	Portugal	Collyer
5th do	Dundalk	.	.	1814	Spain	Armit
6th do	Limerick	.	.	1808	Buen. Ayres	Cane
7th do	Canterbury	.	.	1799	Holland	Collyer
1st Dragoons	Norwich	.	.	1816	France	Hopkinson
2d do	Brighton	.	.	1816	France	Greenwood
3d do	New. on Tyme	.	.	1818	France	Hopkinson
4th do	Bombay	.	1822			Hopkinson
6th do	Dublin	.	.	1816	France	Armit
7th Hussars	Newbridge	.	.	1818	France	Armit
8th do	Longford	.	.	1823	Bengal	Armit
9th Lancers	Hounslow	.	.	1813	Portugal	Greenwood
10th Hussars	Manchester	.	.	1828	Portugal	Greenwood
11th Lt. Drag.	Bengal	.	1819			Collyer
12th Lancers	Dublin	.	.	1828	Portugal	Armit
13th Lt. Drag.	Madras	.	1819			Greenwood
14th do	Birmingham	.	.	1814	Spain	Greenwood
15th Hussars	Nottingham	.	.	1816	France	Greenwood
16th Lancers	Bengal	.	1822			Greenwood
17th do	Limerick	.	.	1823	Bombay	Cane
RL Wag. Train	Croydon	.	Detachments	various periods		Greenwood
Gr. Gds. 1st bat.	Westminster	.	.	1828	Portugal	
2d bat.	Upnor Castle	.	.	1818	France	
3d bat.	Knightsbridge	.	.	1818	France	
Coldst. } 1st bt.	Windsor	.	.	1814	France	
Gds. } 2d bt.	Portman Street	.	.	1818	France	Greenwood
Sc. Fu. } 1st bt.	Dublin	.	.	1814	France	
Gds. } 2d bt.	Tower	.	.	1828	Portugal	
1st Foot, 1st bat.	Trinidad	Glasgow	1826			
2d bat.	Chatham	.	.	1831	Madras	
2d do	Bombay	Chatham	1825			Ashley
3d do	Bengal	Ditto	1828			Greenwood
4th do	Chatham	.	.	1828	Portugal	Greenwood
5th do	Bultevant	.	.	1826	Dominica	Atkinson
6th do	Bombay	Chatham	1821			Greenwood
7th do	Malta	Hull	1825			Greenwood
8th do	Halifax N. S.	Blackburn	1830			Greenwood
9th do	Limerick	.	.	1827	Trinidad	Armit
10th do	Zante	Tralece	1826			Gr. & Ar.
11th do	Santa Maura	Gosport	1826			Hopkinson
12th do	Gibraltar	Mullingar	1823			Gr. & Ar.
13th do	Bengal	Chatham	1822			Greenwood
14th do	Chatham	.	.	1831	Bengal	Greenwood
15th Foot	Quebec	Newcas. on T.	1827			Greenwood
16th do	Bengal	Chatham	1819			Kirkland
17th do	N. S. Wales	Chatham	1830			Greenwood

Regiments and Corps.	Stations of Service Companies or Troops.	Stations of Reserve Companies.	Year of Going on Foreign Service.	Year of Returning from Foreign Service.	Whence Returned.	Agents.
18th do . . .	Vido . . .	Bolton . . .	1821			Greenwood
19th do . . .	Grenada . . .	Weedon . . .	1826			Fitter
20th do . . .	Bombay . . .	Chatham . . .	1819			Greenwood
21st do . . .	Kilkenny . . .			1827	St. Vincents.	Armit
22d do . . .	Jamaica . . .	Plymouth . . .	1826			Greenwood
23d do . . .	Gibraltar . . .	Drogheda . . .	1823			Greenwood
24th do . . .	Quebec . . .	Carlisle . . .	1829			Collyer
25th do . . .	Demerara . . .	Paisley . . .	1826			Collyer
26th do . . .	Bengal . . .	Chatham . . .	1828			
27th do . . .	Fernoy . . .			1831	Barbadoes	Greenwood
28th do . . .	Galway . . .			1830	Corfu	Armit
29th do . . .	Mauritius . . .	Dublin . . .	1826			Greenwood
30th do . . .	Dublin . . .			1829	Madras	Armit
31st do . . .	Bengal . . .	Chatham . . .	1825			Greenwood
32d do . . .	Quebec . . .	Boyle . . .	1830			Hop. & Ar.
33d do . . .	Jamaica . . .	Burnley . . .	1822			Greenwood
34th do . . .	Halifax, N. S. . .	Clare Castle . . .	1829			Gr. & Ca.
35th do . . .	Barbadoes . . .	Plymouth . . .	1820			Greenwood
36th do . . .	Barbadoes . . .	Spike Island . . .	1830			Price & Ar.
37th do . . .	Bermuda . . .	Waterford . . .	1830			Gr. & Ar.
38th do . . .	Bengal . . .	Chatham . . .	1818			Greenwood
39th do . . .	N. S. Wales . . .	Chatham . . .	1827			Greenwood
40th do . . .	Bombay . . .	Chatham . . .	1824			Lawrie
41st do . . .	Madras . . .	Chatham . . .	1822			Greenwood
42d do . . .	Gibraltar . . .	Stirling Castle . . .	1823			Greenwood
43d do . . .	Manchester . . .			1830	Gibraltar	Greenwood
44th do . . .	Bengal . . .	Chatham . . .	1822			Greenwood
45th do . . .	Madras . . .	Chatham . . .	1819			Greenwood
46th do . . .	Madras . . .	Chatham . . .	1813			Greenwood
47th do . . .	Edinburgh . . .			1829	Bengal	Greenwood
48th do . . .	Madras . . .	Chatham . . .	1817			Greenwood
49th do . . .	Bengal . . .	Chatham . . .	1822			Greenwood
50th do . . .	Templemore . . .			1827	Jamaica	Armit
51st do . . .	Corfu . . .	Stockport . . .	1821			Kirkland
52d do . . .	Halifax, N. S. . .	Weedon . . .	1823			Greenwood
53d do . . .	Gibraltar . . .	Chester . . .	1829			Greenwood
54th do . . .	Madras . . .	Chatham . . .	1819			Greenwood
55th do . . .	Madras . . .	Chatham . . .	1821			Greenwood
56th do . . .	Fernoy . . .			1826	Mauritius	Cane
57th do . . .	Madras . . .	Chatham . . .	1825			Greenwood
58th do . . .	Ceylon . . .	Londonderry . . .	1828			Gr. & Ca.
59th do . . .	Birr . . .			1829	Bengal	Armit
60th do 1st bat.	Gibraltar . . .	Dublin . . .	1830			Gr. & Ar.
2d bat.	Manchester . . .			1829	Berbice	Greenwood
61st do . . .	Ceylon . . .	Ballinrobe . . .	1828			Gr. & Ar.
62d do . . .	Madras . . .	Chatham . . .	1830			Greenwood
63d do . . .	N. S. Wales . . .	Chatham . . .	1829			Collyer
64th do . . .	Belfast . . .			1828	Gibraltar	Armit
65th do . . .	Berbice . . .	Kinsale . . .	1829			Gr. & Ar.
66th do . . .	Montreal . . .	Castlebar . . .	1827			Gr. & Atk
67th do . . .	Newry . . .			1826	Bombay	Armit
68th do . . .	Athlone . . .			1829	Up. Canada	Armit
69th Foot . . .	Fernoy . . .			1826	Madras	Cane
70th do . . .	Dublin . . .			1827	Canada	Armit
71st do . . .	York U. C. . .	Glasgow . . .	1824			Price
72d do . . .	Cape . . .	Fort George . . .	1828			Greenwood
73d do . . .	Malta . . .	Truro . . .	1827			Lawrie

BIRTHS, MARRIAGES, AND DEATHS.

BIRTHS.

May 23rd. The Lady of Capt. Howell, R. N. of a son.

May 26th. At Oakville, the Lady of Capt. M. H. Herbert, R. N. of a son.

May 29th. At East Looe, the Lady of Lieut. Gill, R. N. of a son.

May 30th. The Lady of J. Elliott, Esq. Purser R. N. of a daughter.

At Exeter, the Lady of Capt. Truscott, R. N. of a daughter.

The Lady of Colonel Freemantle, of the Coldstream Guards, of a daughter, still-born.

At Athlone, the Lady of Dr. Williams, 68th Regiment, of a son.

June 5th. At Bath, the Lady of Capt. Seton, of the 5th Dragoon Guards, of a son.

June 6th. At Overton House, near Bandon, the Lady of Lieut.-Colonel St. John Clerke, of a daughter.

In Cork, the Lady of Jonathan Croft, Esq. Medical Staff, of a son.

At Hounslow, the Lady of Lieut. Robert Cooke, of the 9th Lancers, of a son.

June 16th. At Long Hill Cottage, near Weymouth, the Lady of Capt. R. Douglas, R. N. Inspecting Commander, Coast Guard, of a son.

At Milford, the Lady of J. Williams, Esq. Purser R. N. of a son.

At Tivoli Gardens, Cork, the Lady of Lieut.-Colonel Day, of a daughter.

June 23rd. At Blackbrook Cottage, near Fareham, the Lady of G. T. M. Purvis, R. N. of a son.

MARRIED.

Jan. 1st. At Kundy, Ceylon, Lieut. M'Intyre, 78th Highlanders, to Eliza, daughter of James Hadden, Esq. of Persley, Lord Provost of Aberdeen.

May 7th. At Malta, Lieut. the Right Hon. the Earl of Rothes, of the Royal Fusiliers, of Rothes Castle, Elginshire, and Leslie Castle, Fifeshire, to Louisa, third daughter of Colonel Anderson Morshead, of Widey Court, in the county of Devon, commanding Royal Engineer at Malta.

May 19th. At Carlsruhe, Grand Duchy of Baden, Capt. Drummond, late of the 93rd Highlanders, heir presumptive to the Earldom of Melfort, in Scotland, (should his Majesty be pleased to restore that title,) to the Baroness Albertine de Rotberg-Kheinweiler, widow of the late Gen. Count Repp, Peer of France.

May 19th. At St. George's, Bloomsbury, Lieut. R. B. Cotgrave, R. N. to Emily Henrietta, youngest daughter of R. Ellis, Esq. of Torrington square.

May 24th. At Brighton, Lieut. George Burroughs, R. A. to Selina, eldest daughter of the late Colonel Childers, 11th Light Dragoons, and of Cantley, county of York.

June 1st. At St. Margaret's, Westminster, Lieut. G. Mason, R. N. to Ann, eldest daughter of W. Whitehead, Esq. of Teynham, Kent. The bride was given away by Lord Adolphus Fitz-Clarence.

June 2nd. At Hythe, Kent, Robert Marshall, Esq. M. D. Surgeon R. N. to Sarah, eldest daughter of D. Major, Esq. of that place.

At Brinny Church, County Cork, Capt. the Hon. William Smyth Bernard, half-pay, 1st Dragoon Guards, brother of the Earl of Bandon, to

Elizabeth, only daughter of Lieut.-Colonel Gillman, of Clancoola, late of the 81st Regiment.

At St. Mary's, Bryanstone-square, Capt. John Davidson, of the 2nd Life Guards, to Augusta Catherine, second daughter of Mr. and Lady Sarah Bayly.

At Anthony, Lieut. J. Kemp, R. N. to Susanah, daughter of J. Pryn, Esq. H. M. Customs, Fowey.

June 7th. At Daviot House, Invernesshire, Capt. Angus Macintyre, late of 41st Regiment, to Margaret, daughter of the Hon. Angus Mackintosh, of Mackintosh, Capt. of Clanchattan, &c. &c.

June 7th. At Laura Church, near Birr, Lieut. E. Evans, 38th Regiment, to Eliza, daughter of Thomas Antisell, Esq. Sraduff House.

June 7th. At Merstham, Surrey, John Hennen, Esq. M. D. of the Royal Military Asylum, to Miss Phillips, of Hill Lodge, near Winchester.

June 9th. At Bath, Capt. Ellis, of the 4th Light Dragoons, eldest son of the late Colonel Ellis, of the 25th Light Dragoons, to Eliza Georgiana, eldest daughter of Colonel J. L. Richardson, of the Bengal Service.

June 10th. At St. Mary's Church, Dublin, by the Rev. G. Kelly, Edward Josias Bulteel, Esq. Surgeon to his Majesty's Forces, to Sarah, eldest daughter of the late David Kelly, Esq. of Sligo.

June 14th. At Kilmallock Church, County Limerick, Capt. King, late 7th Hussars, nephew to Earl Kingston, to Miss Coote, daughter of Chidley Coote, of Mount-Coote, in that County, Esq.

At St. Mary's Church, Cheltenham, Capt. M. Carmichael Smyth, Madras Light Cavalry, to Marianne Henry, youngest daughter of the late Alderman Hutton, of Dublin.

June 16th. At St. Mary's Church, St. Mary-le-bone, Lieut. H. E. Beville, 5th Dragoon Guards, to Charlotte, eldest daughter of G. N. Thompson, Esq. of Chapel Street, Grosvenor Place.

June 18th. At St. George's Hanover Square, Robert Marsh Westmacott, Esq. Capt. in the 98th Regiment, and second son of Richard Westmacott, Esq. to Louisa Marlan, eldest daughter of the late Rev. George Plummer, Rector of North Hill, County of Cornwall.

June 21st. At Waterfall Church, Lieut. Charles Lee, 77th Regiment, to Emma, daughter of Thomas Austin, of Waterfall, Esq.

At Alton Church, Hants, Capt. S. B. Haines; Royal Navy, to Miss Mary Stanley, daughter of George Sauley, Esq. of Anstey, near Alton, Hants.

June 23rd. At Woodmancote, Sussex, R. Redmond Caton, Grenadier Guards, eldest son of the Rev. R. B. Caton, of York Street, Portman Square, and of Binbrook, Lincolnshire, to Anna Maria, only daughter of the Rev. John Bideout, Rector of Woodmancote, and grand-daughter of the late Sir Harry Goring, Bart.

DEATHS.

Colonel the Earl of Lisburne, late Sheffield Regiment.

LIEUTENANT-COLONELS.

April 27th, 1831. Lapalie, h. p. 30th Foot.

May 6th. At Bishops Stortford, Wilby, h. p. 31st Foot.

CAPTAINS.

Macdonell, 10th Dragoons.

Oct. 26th, 1830. At Moreton Bay, New South Wales, Logan, 57th Foot, killed by the Aborigines.

Feb. 8th, 1831. At Downie House, Argylshire, Clerk, h. p. 27th Foot.

March 31st. At Malta, Patullo, Royal Artillery.

April 26th. Affeck, h. p. Independents.

LIEUTENANTS.

Dec. 26th, 1830. Bradshaw, h. p. 104th Foot.

Feb. 7th, 1831. Milne, h. p. 42nd Foot.

April 23rd. Little, h. p. 40th Foot.

April 27th. At Nealing, Lincolnshire, Loft, 62nd Foot.

May 3rd. Gormon, h. p. 41st Foot.

May 13th. At Shannon-Bridge, Athlone, King, 68th Foot.

ENSIGNS.

April. Liston, 81st Foot. Lost on passage home from Bermuda, on board the brig Bulow.

May 4th. Moore, h. p. 71st Foot.

QUARTER-MASTERS.

Nicholson, 17th Dragoons.

March 15th. At Hounslow, Body, h. p. 11th Dragoons.

March 24th. Tennent, h. p. 19th Dragoons.

April 22nd. Sweeney, h. p. 6th Dragoon Guards.

April 23rd. King, h. p. 13th Dragoons.

Woods, late 7th Royal Veteran Battalion.

SURGEON.

Jan. 19th. At Hanover, Surg. Neumann, h. p. 6th Line German Legion.

ASSISTANT-SURGEONS.

Jan. 20th. At Sea, Urquhart, 46th Foot.

May 4th. Gamble, h. p. 34th Foot.

May 21st. Thomson, 13th Dragoons.

Jan. 2nd. Lieut.-Gen. Sir Gabriel Martindell, K.C.B. commanding the garrison at Buxar, East Indies.

Jan. 19th. At Mabableshwur Hills, his Excellency Lieut.-Gen. Sir Thomas Sydney Beckwith, K.C.B. Governor and Commander-in-Chief of the Presidency of Bombay. He was appointed a Lieutenant in the 71st Foot in 1791; Captain 4th August 1794; and Captain in Maningham's Corps of Riflemen, (afterwards the 95th Foot, and Rifle Brigade,) 29th August 1800; Major in 1802; Lieutenant-Colonel in 1803; Colonel in 1811; Major-General in 1814; and Colonel-Commandant in the Rifle Brigade 27th January 1827. He served with much distinction in Spain and Portugal. As Lieutenant-Colonel he served at the battles of Vimiera, Corunna, and Busaco. In 1810 he was appointed to the Staff of the army in Spain, first as a Deputy and next as an Assistant-Quarter-Master-General; and he afterwards served as Quarter-Master-General in Canada. For his services he was honoured with the Order of the Bath, and Tower and Sword of Portugal, as a Knight Commander.

At Bermuda, Lieut.-Colonel Lloyd, R.A. deeply regretted by his brother officers and a numerous acquaintance at Bermuda. He was buried with military honours at St. George's on the 27th May.

At the Isle of Wight, Commander E. Roberts, R.N. aged 55.

At Haslar Hospital, Mr. R. D. Mosherby, Purser R.N.

May 17th. At Malta, in the 28th year of his

age, Mr. Thomas Douglas Eabelby, Surgeon of His Majesty's Ship Scylla.

May 27th. At Coates, Sussex, Lieut. Thomas King, R.N. aged 22, youngest son of the late John King, Esq.

May 28th. After a short but severe illness, in the 74th year of his age, the Right Hon. William Earl of Northesk, Baron Roschill and Inglismaldie, G.C.B. and LL.D. Admiral of the Red, Rear Admiral of Great Britain. A memoir of this lamented officer will be found in our present number.

May 30th. At Chatham, Major W. H. Snowe, of the Royal Marines. The death of this officer was occasioned by a fall from his horse, which took fright and became restive, on the Saturday preceding, at the troops firing a feu de joie, at the review at Chatham, in celebration of his Majesty's birth day.

At Limerick, Commander A. C. Stanton, R.N. At Pilton, near Barnstaple, Capt. Richard Pellowe, R. N. He was First-Lieutenant of the Nymph, commanded by Capt. Pellew, now Lord Exmouth, in the action with and capture of the Cleopatra French frigate.

At Wiveliscombe, Capt. Henry Hodge, on the Retired List of the Royal Marines.

At Cork Barracks, in his 19th year, of dysentery, Cornet Thomas Holme Bankes, 6th Dragoon Guards.

In Dublin, Capt. Daniel Hull, in the 72nd year of his age, late of the 12th Royal Veteran Battalion; an officer who had served his King and country with honour and fidelity for 54 years.

At Donaghadee, Major Hull, formerly of His Majesty's 62nd Regiment.

At Cork, Henry Wrixon, Esq. of Blossomfield, late Captain 16th Light Dragoons.

June 5th. Lieut. J. A. Phillips, R. N. son of Capt. Phillips, of Torr House, Devon. He was seized with the cramp while bathing under the Hoe, and was drowned.

June 7th. At Widcombe House, near Bath, Capt. Matthew Wrench, R.N.

June 11th. At East Wickham, Kent, John Jones, Esq. formerly Lieutenant-Colonel 1st Foot Guards.

Lately, on the coast of Africa, Mr. Collins, Master of the Medina.

June 15th. At Plymouth, Capt. Thomas Innes, R.N.

June 16th. At Woodend, Hampshire, Admiral Sir John Knight, K.C.B. aged 83. A Memoir is given in our present Number.

June 18th. At his residence, Yates-Court, Kent, Vice-Admiral Viscount Torrington, aged 62. A Memoir is given in our present Number.

June 19th. After a short illness, Capt. Sir Murray Maxwell, C. B. R. N. We expect to be enabled to give a Memoir of the services of this distinguished officer in our next Number. He had recently been appointed to the Government of New Brunswick.

Lately, Capt. Charles Otter, R.N.

At Brambridge House, Twyford, Hants, Lieut. C. A. Antram, R.N.

June 23rd. At Titchfield, after a long illness, Capt. Edward Covey, Royal Engineers, aged 35 years.

June 24th. At Porchester, Major Mark, formerly of the 57th Regiment.

METEOROLOGICAL REGISTER,

KEPT AT THE OBSERVATORY OF CAPT. W. H. SMYTH, AT BEDFORD.

MAY. 1831.	Six's Thermometer.		At 3 P. M.			Fluvia- meter Inches.	Evapora- tor Inches.	Winds at 3 P.M.
	Maxim. Degrees.	Minim. Degrees.	Barom. Inches.	Thermo. Degrees.	Hygrom. Parts.			
☉ 1	53.9	51.3	29.47	53.9	545	—	.080	S.W. by W. light br. fine.
☉ 2	57.8	50.3	29.52	54.4	585	.120	.092	S.W. fresh br. and clear.
☉ 3	58.9	50.8	29.61	55.8	620	.240	.090	S.S.W. fr. breezes, squally.
☉ 4	56.0	50.7	29.53	52.9	620	.232	.070	W.N.W. fr. br. showers.
☉ 5	56.0	45.8	29.52	52.8	563	—	.150	W. by S. light br. clouds ria.
☉ 6	53.1	47.0	29.83	47.8	503	.070	.153	N.W. fr. breeze, fine day.
☉ 7	52.0	40.8	30.05	50.7	346	—	.100	N. to N.E. light br. fine mor.
☉ 8	52.2	44.0	30.23	51.1	492	—	.150	N.N.E. fr. br. cl. gathering.
☉ 9	57.2	44.8	30.20	50.7	459	—	.135	N.E. light breeze, fine day.
☉ 10	50.8	48.0	30.15	52.5	520	—	.100	N.E. fresh breezes, squally.
☉ 11	61.2	46.7	30.16	58.0	325	—	.200	N.N.E. fresh br. very fine.
☉ 12	62.1	46.8	30.03	59.0	302	—	.080	W. by N. light br. fine day.
☉ 13	60.8	52.0	30.02	55.6	476	—	.100	N. by E. fr. breezes, squally.
☉ 14	59.6	49.2	30.06	55.8	440	—	.120	N.N.E. light br. freshening.
☉ 15	60.0	45.9	30.09	56.0	385	—	.124	S. to S.W. light airs, and fine.
☉ 16	65.1	50.8	30.13	60.4	346	—	.133	N.N.E. light airs and calms.
☉ 17	67.8	50.7	30.13	63.3	362	—	.200	N.N.E. moderate br. fine.
☉ 18	67.6	55.8	30.04	65.8	336	—	.160	N.E. very fresh breeze, fine.
☉ 19	63.2	50.3	29.92	61.2	450	—	.200	N.W. bl. a gale, showery.
☉ 20	66.2	50.3	29.84	66.2	429	.170	.200	N.E. light airs and calms.
☉ 21	63.4	55.6	29.92	61.7	530	.378	.050	N.N.W. light breeze, cloudy.
☉ 22	61.8	56.2	30.00	60.2	689	—	.080	N. by E. light airs and calms.
☉ 23	66.8	67.0	29.92	68.9	535	—	.050	N.E. by N. light airs, fine.
☉ 24	70.6	60.9	29.87	68.2	639	—	.185	E. to N.E. fresh br. hazy.
☉ 25	70.7	50.2	29.80	67.2	465	—	.100	N.E. fresh breeze, fine.
☉ 26	70.8	58.8	29.86	61.3	553	—	.096	N.N.E. blowing fresh, sq.
☉ 27	61.0	56.2	29.84	59.3	559	—	.080	N.E. fresh breezes, cloudy.
☉ 28	62.0	54.8	29.94	62.0	541	—	.056	W. by N. light breezes, fine.
☉ 29	63.6	57.2	29.96	58.0	564	.185	.080	N.W. light airs and cloudy.
☉ 30	64.4	54.0	29.94	64.4	360	.158	.079	N. by W. light and calms, fine.
☉ 31	64.2	53.4	29.95	64.2	437	—	.100	N.N.E. fresh br. heavy fog.

TO READERS AND CORRESPONDENTS.

WE this month give an extra half-sheet, in order to introduce a detailed report of the meeting held to establish the NAVAL AND MILITARY LIBRARY AND MUSEUM, upon the auspicious foundation of which we are happy to be enabled to congratulate the United Service.

Will "Milo," who was evidently an eye-witness of what he describes, authenticate *confidentially* the details he has been so kind as to communicate, and which, by report, are already familiar to us? Our Correspondent will understand why we are scrupulous when dealing with such a subject.

We have done our best for "D.D."

We will readily receive "P.'s" proffered communications on "professional subjects."

We shall take up the subjects alluded to by "An Observer."

We regret having been compelled to defer the communications of "N. C.," "Nauticus," and others.

We are compelled to defer the continuation of Dr. Bennett's Narrative of his recent visit to several of the Polynesian Islands till our next.

A VOICE FROM THE ARMY.

Quæ Regio in Terris nostri non plena laboris?

SINCE the creation of the British Army, there has not occurred a period, at which full justice to the claims of its members has been more imperatively called for, or when circumstances more clearly pointed out its value to the state, and the mischiefs of well-founded discontent on the part of that important branch of the National Force. It is our province to set forth and advocate those claims in general, and in the particular case which now demands our notice, we shall simply appeal to that spirit of justice by which the existing Administration professes to be exclusively actuated.

From the earliest ages, Armed Bodies have been of necessity employed to cement or control the discordant elements of society—to protect their native hearths and altars—extend civilization, and speed the intercourse of man, and the interchange of his and Nature's productions, from Pole to Pole. Armies, and we use the term as implying any armed and organized Force, traversing sea and land, were, the founders and the bulwarks of States—

“Le premier qui fut Roi fut un Soldat heureux,”

and Valour and Virtue became convertible terms in the language of those who “came, saw, and conquered.”

Nor were the paramount influence and exercise of the Military principle confined to any *form* of Polity;—it pervaded all—whether Regal or Republican. Interwoven with every Public Institution and sustaining the Social Fabric, Military Service was the first and indispensable duty of every Citizen—Military Virtue his highest distinction—and Military Honours his loftiest aspiration. Such were more especially the spirit and the practice of those far-famed Nations who founded Freedom upon a popular basis; but who, overborne by the despotic tendency of democratic Institutions—the other and worst extreme of tyranny—abused and cast down that Idol it was their error to have worshipped under an incompatible form.

The standing Army of Great Britain, during the century and a half of its existence, has well supported the high pretensions of its immemorial calling. Brave—faithful—patient—and amenable to strict discipline, the troops of Great Britain have served the cause of their country with constant zeal and progressive improvement, from the days of Blenheim to those of Waterloo. How they bore their part in the great and protracted struggle for national freedom or submission to French tyranny, it were idle to repeat here;—they delivered their fatherland and Europe from the common foe, winning unfading glory and a popularity alike just and enduring. Notwithstanding the occasional buzzing of the political gad-flies who infest and worry the State, the Army and Navy are regarded with pride and respect by the British Nation, to whose substantial interests they minister, and over whose honour and security they watch. Injustice or ingratitude to these indispensable and efficient bodies are, we are confident, utterly repugnant to the great mass of the People, who are enabled by the vigilant and intrepid intervention of the Army and Navy, to apply

themselves, in full security, to their respective pursuits, and taste undisturbed the sweets of domestic enjoyment.

These observations are introduced, not in an idle spirit of vain-glory or recrimination, but to lead us to the position upon which we base our appeal—namely, that **FACTION** should in no case be permitted to prejudice the administration or lower the proud spirit and efficiency of the *United Services*—the twin pillars of the State.

In the following remarks we address ourselves more especially to the concerns of the Army, because a measure of injustice towards a class of its members, and through them to the whole, has been recently discussed in Parliament, and decided upon elsewhere;—we allude to the exclusion of military officers from the enjoyment of their professional emoluments when holding civil office, while that indulgence is invariably permitted to officers of the Sister Service.

It has ever occurred to us as passing strange, that “vested rights” which are held “sacred” as regards the non-combatant classes of this investing community, should be deemed non-existent in the Army—that its most important interests and prerogatives should be matters of caprice—while it is subjected to a double code of pains and penalties by distinct laws for its immediate Government.

While Europe still resounded with acclamations for the victory of Waterloo—while admiration and gratitude for the services of those who achieved it, and sympathy for the brave men who had fallen, were at their highest in England, his late Majesty, with characteristic benevolence, ordered, as a mark of his satisfaction with the conduct of the British Army, that pensions for wounds or disabilities contracted in the service, should increase with the progressive rank of the officers holding them.* This boon, unsolicited and unexpected, was hailed with twofold enthusiasm and cheering anticipations by the Army. Calculations and arrangements for the future were confidently made—responsibility was incurred—pledges given—and marriages contracted, upon the strength of a provision spontaneously conferred and solemnly guaranteed. Yet within two little years—ere yet the salt of most righteous tears had ceased to scald the cheek of the widow and the orphan—ere those ranks who most needed the boon had time to profit by its operation—the grant was suddenly and recklessly cut off,† and numbers of British officers, who dreamed not of broken faith with those whose stont arms propped the credit of the nation itself, were ruined!

We have been told that the sacrifice was demanded by the state of the national finances. While we admit the expediency of reduction at the period in question, we deny the justice of its application in the case we have stated. Why smother the bees that drones might batten on the honey? If economy was a duty, as no doubt it was, there were *other quarters* in which it might have been exercised with profit to the State, and without ruin or injustice to individuals. But no—the Army, by some perversion of justice and policy, has ever been made the scape-goat of every cuckoo cry for reduction. We will state anon why they should be the very last thus affected.

In 1818, the House of Commons, feeling the debt of gratitude which

* Dated 31st July 1815.

† Dated 30th June and 25th of August 1817.

was due to the Army for its eminent Services, and recommending at the same time a large reduction of its members on the return of the Army of Occupation from France, came to a resolution, almost unanimous, that officers reduced on half-pay should be eligible to Civil Office, which, prior to this period, they could not accept without forfeiting their military pay; and in consequence of this feeling, so expressed, the War Office Circular of the 23rd July 1819,* was issued.

As a question of common sense and equity, the half-pay of an officer is an annuity for value received, or admitted to be received—and as such becomes his indisputable property. At all events it is a remuneration for past military services, combined with an obligation on the part of the officer to return to his military duties when called upon, provided his health will allow him to do so. As a point of law, it was unequivocally decided in favour of the holders of half-pay, in the case of the late Duke of St. Alban's, as a half-pay Lieutenant of the Navy, who brought the matter to trial.

We do not discuss or question the propriety of so modifying the enjoyment of half-pay, that it shall be strictly a *quid pro quo* dependent upon not less than a fixed number of years' service, or other *prospective* conditions,†—but we maintain that under the then existing regulations and understanding, any restrictions upon officers on half-pay—especially such as have been obliged to retire, contrary to their wishes and interests, by reduction or disability,—are unjustifiable in any sense, as well as wholly unprofitable to the country.

We ask, upon what grounds of expediency, justice, or economy are half-pay officers precluded from a privilege common to all other classes of British subjects? The pensioned civilian is master of his own actions and pursuits. Half-pay, if granted for any public consideration at all, is clearly a remuneration for past service: if it have been indiscriminately bestowed alike upon the tyro and the veteran, still the general principle remains unaffected. What matters it to the nation whether a subaltern retains his fifty or sixty pounds a-year, while endeavouring to maintain himself above penury by a new pursuit? He is entitled to his half-pay, or he is not: if the former, he has a right to its usufruct under any circumstances while

* CIRCULAR 417.

War Office, July 23rd, 1819.

Any officer holding any place or emolument of profit under the crown, the net annual emoluments of which do not exceed three times the amount of the highest rate of half-pay, attached by regulation to the rank in virtue of which he is entitled to half-pay, may upon application to the Secretary-at-War, be permitted to receive a military allowance equal to, and instead of, his half-pay, upon making an affidavit in the following form, &c.

If the net annual emolument of the civil place or employment exceed three times, but fall short of four times the amount of such half-pay, they may upon application at the end of the year receive so much of their military allowances as together with those net annual emoluments, may be equal to four times the amount of such half-pay upon making affidavit in the following form, &c.

By Act 1, Geo. 4, Cap. ii.—Half-pay not receivable with emoluments from a civil situation under the crown to which an officer may be appointed after July 28th, 1828, (in consequence of a recommendation of the Finance Committee, 1828.)

† Effected by a late regulation, for the purpose of correcting certain abuses, by which individuals who had never joined a regiment became Military Annuitants for life.

he holds his commission; to deprive him of his "vested right" because he fills a vacancy in another calling without prejudice to his own, from which he is alienated by involuntary causes, and to which he is ready to return, if capable, when required, is a paltry subterfuge unworthy of the country. The prohibition, on public grounds, appears wholly inexpedient, and, as affecting a particular class, is illiberal and partial. To turn his leisure to useful and profitable account is not surely a derogation on the part of a British officer deserving so severe and exclusive a penalty; and, on every account, we hope the question may attract early consideration and revision in the proper quarters.

We shall now proceed to expose the corresponding deprivation with which General Officers are threatened.

In 1829, Sir Henry Hardinge stated in the House of Commons, in reply to a notice of Mr. R. Gordon, that the injustice done to officers on half-pay by the Finance Committee in 1828, was no reason why an *innovation* of a similar tendency as affecting General Officers holding regiments on full pay unattached, should be enforced by the advocates of retrenchment in the House,—quoting, at the same time, the case of the Duke of Marlborough as having held the offices of First Lord of the Treasury and Master-General of the Ordnance, with the Colonelcy of the 1st Regiment of Guards and the post of Constable of the Tower, (precisely the offices held by the Duke of Wellington,) without any curtailment of his military emoluments, because he also held civil appointments. The selection of such a subject for retrenchment, we are forced by circumstances to infer, was suggested rather by the spirit of party than of economy, originating, as it appears to have done, in a desire, on the part of Sir James Graham, to attack the emoluments of the Duke of Wellington and Sir George Murray, then Ministers of the Crown.

Of the appointments of the Duke of Wellington we cannot stoop to speak palliatingly. His services are as far beyond price, as his lofty character is above the appreciation of the little-minded of his countrymen. Sir George Murray, after forty years of brilliant and arduous service, enjoys about 1500*l.* per annum; and had, we venture to think, as strong claims to his Ministerial salary, as, *mutatis mutandis*, the present First Lord of the Admiralty, of whose previous public services there is no record. It is remarkable that office should have wrought so diametrical a change in the financial views of the First Lord, who, as Minister, supports in the case of the Naval Lords of the Admiralty, an "indulgence" which he condemned in that of His Majesty's Military Ministers, when himself in Opposition.

The following passage, taken from the Report of the Select Committee on Reduction of Salaries, establishes this contradiction.

"FOUR LORDS OF THE ADMIRALTY.—The salary of £1000 a-year existed in 1780, and remains unchanged to the present time, each Lord having also an official residence. It is not intended to propose any alteration. As a general principle, the Committee are of opinion that no Military or Naval officer should be allowed to receive any Military or Naval whole or half-pay during the period that he holds any civil office. They are induced, however, to recommend an exception in favour of any of the Lords of the Admiralty who may be in the Naval Service, from a consideration that without such indulgence their Salaries might not be a sufficient remuneration for their Services."—*Report*, p. 8.

We would ask why and in what degree is this indulgence less

desirable or applicable to the Military officer under parallel circumstances?

Since the reign of Queen Anne, there has been no improvement in the pay of officers of the British Army, their income being considered with reference both to its relative value and positive amount. In fact, the advantage is with the former period. The pay of the soldier has been doubled. The case of General Officers is peculiar. The prospect of receiving pay graduated and fixed to their ranks as General Officers, was as short-lived as the hopes of the candidates for increase of pensions for wounds. The warrant was annulled, the number to receive the unattached pay being limited, by gradual reduction, to 120, at 25s. a day (18th February 1818,) and that only under certain conditions as to regimental service. By this measure, the sum of 23,000*l.* annually, or a total to this date of nearly 300,000*l.* has been saved to the country, at the expense of the General Officers who served it with distinction during the war. A General Officer, promoted subsequently to the above date, receives, therefore, merely *the pay of his last regimental commission*, although he may have purchased the latter at the outlay of his whole private fortune. On the other hand, British Admirals, who cannot have purchased their commissions, receive at once the half-pay of their respective ranks as *Flag Officers*. The hardship involved in this disability of holding professional pay with civil emolument, though unjust to both services, will be found, therefore, to press most heavily on the Military. If it be pleaded that the civil salary is in itself an adequate remuneration to the party holding office, even at the sacrifice of his professional emoluments, we deny the assumption. On the contrary, we have good reason to believe that the Military Officers who had the honour to serve as Ministers before those now in office, were as decided losers in pocket, as they have been gainers in the respect and confidence of the country.

Nor is it alone with respect to officers considered *Civil*, like the Governments in India for instance, that this prohibition operates injuriously: it similarly affects posts of honour or courtesy, as those about the court and the person of the Sovereign, held by distinguished officers. Such as Sir Herbert Taylor, Sir Andrew Barnard, Sir Henry Blackwood, &c. from motives of personal attachment to or on the part of the *Royal Family*.

On a late occasion* when the salary of the President of the Board of Control came before the House, Sir Henry Hardinge, who vigilantly watches the interests of his profession, inquired of Lord Althorpe whether the Government had determined to adopt the recommendation of the Salaries' Committee as regarded General Officers—to which his Lordship replied, that "As there was no case of any military general officer holding civil office in the existing Government, he had not thought it necessary to come to a decision until the case should arise."

The general arguments we employed in the case of the half-pay will apply equally to that of the General Officers—and we have strong hopes that on a dispassionate view of the meditated deprivation affecting the latter, it will appear to his Majesty and the Government both inexpedient and impolitic to adopt the arbitrary and invidious recommenda-

* See the Parliamentary Proceedings in our Register.

tion of the Committee. Such a proceeding, coupled with the glaring injustice to the half-pay, would naturally create an impression that it was the object of the present Government to drive military officers from any participation in civil employment—to render them, as it were, an exclusive caste—instead of, with a wiser and more constitutional policy, throwing open to them the door of office, and thus neutralizing the alleged ambition of military adventurers and danger of standing armies, by associating them in the responsibility, honours, and concerns of the State. The barefaced assertion occasionally palmed upon the better sense and experience of Parliament, by certain stolid and case-hardened members of its body, namely, that the capacity of military men for civil office is inferior to that of the other classes, refutes itself. A glance at the most eminent public men at home, and at those who administer our colonies in every region of the globe, will suffice to expose the clap-trap fallacy.

In a late debate on the Army Estimates, Sir Henry Hardinge informed the Secretary-at-War, (Sir Henry Parnell,) that if the latter did not himself bring forward some resolution, in mitigation of the case of the half-pay, when the Appropriation Act came before the House, he (Sir Henry Hardinge,) would do so. We trust that upon such an occasion, the gallant officer will not fail to receive the zealous support and co-operation of his comrades, and of the independent members of the House. With a view to meet any imputation as to the motives of Sir Henry Hardinge and his late colleagues, it is proper to remark, that any exertions in favour of the army they may now see fit to make, must be more than usually unprejudiced by party, being the due result of an upright discharge of their public duty, when themselves in office. The scrutiny of the Finance Committee of 1828, so far from being encountered with evasion by the Secretary-at-War of 1829-30, (Sir Henry Hardinge,) was met in a corresponding spirit in every point where a fair objection had been taken. Proven abuses were sedulously and impartially corrected, many hundreds of disqualified individuals who had purchased commissions merely as an investment of money, were rooted out of the service upon a commutation—and a warrant was finally issued, regulating, with due proportion and precision, the fiscal transactions of the army. Having performed this duty, if not to perfection, at least with unquestionable zeal and integrity of purpose, Sir Henry Hardinge *then* declared, and has repeated his determination, in the event of the Government not doing so, to bring forward the case of military officers, especially those on half-pay, in order that justice might be as effectually done *for* as *against* them.

As a proof of the arbitrary manner in which the members of the Army are dispossessed or disfranchised by legislators, who appear to think retrenchment can reach no victim but a soldier, we adduce the fact that the Report of the Committee of 1828, already referred to, after lauding the Army for its exemplary and important services, proceeds to excommunicate its half-pay officers from participation in civil employments, without offering *the slightest evidence* in justification of so harsh a proceeding! Nor were any Military Officers consulted as to the expediency of the restriction. The Report simply gives a return of the number of officers so employed.

At the close of the War the officers on full and half-pay of the Line were as follows:—

On Full Pay.		Half-Pay.	Total.
1815	13,500	4,900	18,400
1830	6,178	8,732	14,910
			3,490

Add officers of Artillery and Marines who have, by the sale of their Commissions, been placed on the half-pay of the Line

600

4,090

Thus it is clear that the half-pay has been reduced since the Peace and up to 1830, by more than 4000 officers, although the number in 1830 is double what it was in 1815; because the half-pay is always in proportion to the number of officers reduced from full pay, and the real reduction accomplished is of course the difference between the whole of the numbers of officers on full and half pay, as they existed in 1815, and in 1830.

Out of an aggregate of 13,000 officers, of whom 7000 are on half-pay, it appears that there are scarcely ninety of the latter holding situations *purely civil*, and averaging about 150*l.* a year! In what, then, consists the economy of the exclusion, or how is its propriety justified? Other persons would hold these offices if the half-pay were restricted from accepting them. The rule of 1819, by which civil office might be held by forfeiture of a *portion* of the officer's pay, was less inexcusable, though still oppressive. Our legislators reverse the practice of the Romans, who suffered none to fill a civil office (the functions of religion excepted), *unless he had served ten years in the Army.** But the Romans were dark and dull dogs, familiar with triumphs and ovations, but innocent of the March of Intellect.

We cannot do better than quote here parts of the evidence of Sir Henry Hardinge, given before the Select Committee in March last, which bear, with characteristic force, upon the question we are treating:

“ I need make no comments to this Committee on what would be the feeling in the Military profession if, at the Board of Admiralty, Naval Lords were to be allowed to receive their naval pay with the salary of a civil office, whilst the Officers of the Army at the Board of Ordnance, for instance, were not to be allowed the same advantage. At that Board, the Surveyor General of the Ordnance must, *ex officio*, be a Military or a Naval Officer; it has been held by both. The Salary fixed for Surveyor General of the Ordnance is 1200*l.* a year; the pay and emoluments of a regiment held by a General Officer are 1000*l.* on an average. If the pay and emoluments were to be abated, being obliged to reside in London, and to be in Parliament, he would receive 200*l.* a year for performing the laborious duties of Surveyor General. If the pay were to be abated, and the emoluments granted, the Committee will see the position in which this Military officer would be placed. The emoluments of the regiment fluctuate, sometimes by the loss or damage of the clothing, going out to foreign stations, or by the failure of the agent; if you take away the Colonel's pay, and give him the emolument only, he would frequently be liable to great losses; for instance, for the first year after obtaining a regiment, the Colonel seldom has any emolument. I know instances in which, by the failure of agents, General officers have lost 1500*l.*

* Πολύτιμον δὲ λαβεῖν ἀρχὴν οὐκ ἔχουσι οὐδενὶ κερταίον, ἵνα μὴ δίκᾳ στρατίας ἰσχυροῦς ᾖ τιτιλιώδης.—Polyb. lib. vi. 17.

or 2000*l.* which I, as Secretary at War, have been obliged to levy on the Colonel, who by his responsibility secures the public from all loss. I do not see how, with any degree of justice, the Committee can recommend to take away the pay from the General Officer, the pay and the emoluments being so intimately connected: they form part of his reward as a General Officer. I have taken the last ten cases of General Officers who were appointed to be Colonels of regiments, and I find that in almost every instance the General Officers had purchased their commission, some having paid as high as 10,000*l.* in cavalry regiments, but on an average say 5000*l.* In these ten cases, the average service was thirty-nine years, and the average age fifty-five years, before they received this the chief reward of a military man's life, having forever sunk 5000*l.* of their private fortune in the purchase of their commissions. I therefore maintain, that if the Public Service requires the information of a Military Officer in a civil department, it would be, in my humble opinion very hard and unjust to take away from the most able and distinguished Officers of the Army the reward of their whole military lives, placing them on the same footing as you would the clerk of the Ordnance, or any other civil officer, who may not bring into the department any professional knowledge, who may not have done the public a week's service, who has not undergone any military hardships in our colonies, or in campaigning in the field, and other fluctuating services to which the military officer is liable. I maintain therefore in justice to the Army, that the profits of a regiment being the professional earnings of an officer's life, if he is selected to hold any civil office, his military pay ought not to abate. In the Law, in the case of the Attorney General, or the Judges, or the Lord High Chancellor, who has perhaps for thirty or forty years of his life been making a large fortune by his abilities in his profession, the salary of his civil office is not regulated by any consideration of what he has earned previously to his appointment to a Government office, which in addition frequently confers a large retiring pension. I beg to observe to the Committee, that no Military Officer on full pay, unless he be a General Officer, can receive civil office with his full pay; it is a mistake to suppose it to be so. While I was Secretary at War, and on half-pay, I did not receive my half-pay with my civil office, but I did not consider that as a hardship, because it was the rule of the Service; but it never has been the rule of the Service, from the Duke of Marlborough's time to the present, that when you have obtained the rank of General Officer, an officer should be deprived of his full pay because he holds civil office. There are at the present moment about 13,000 officers in the service on full and half-pay, of which there are only about 130 that can obtain this reward of a regiment, in value 1000*l.* a year, late in life, the officers so selected for the civil service being generally an officer of ability in his profession; to bring him down to the level of a junior officer, or any other person in a civil office, would, in my opinion, be a most harsh proceeding.

“As to half-pay officers?—In reply to the question that has been put to me, I have to state, that the law of 1820 was changed by the Finance Committee in 1828, and at present no officer can receive half-pay with his civil office. This change operates with much severity on individuals: I will mention a case, in which a Lieutenant, highly educated, but of a poor family, went to Spain; he became a cripple in his legs, not by wounds, but by exposure to wet, and sleeping out at night, and for several years has been obliged to be lifted when he moves. Not having been wounded in the field, he is not entitled to a pension, so that he has, after receiving the best education a gentleman can receive, about 6*s.* or 7*s.* a day to live upon for the remainder of his life, without any hope of improving his condition. He made application, being a very good draftsman, to be employed at the Tower under Colonel Colby, who would have employed him; but I was obliged to tell him, as Secretary at War, that he would not, under the Appropriation Act, receive half-pay, and the Government money from the Survey department. If it had been a private land-surveyor's office, there would have been no objection to his improving by his talents his scanty income. This individual is

entirely excluded from the hope of ever returning to his profession ; he never can serve in the army ; he is condemned, under the Appropriation Act, to continue to live in ill health upon 6*s.* or 7*s.* a day, though his qualification to serve under Government in a sedentary office is as good, and perhaps better, than many other individuals. Again, in Canada, where the population is thin and scattered, it is very desirable to have gentlemen to act as magistrates ; half-pay officers are there located on small farms. The rule was, after the year 1820, to give them forage for a horse, and travelling expenses when they came to the quarter sessions to act as magistrates. The stipend might be 30*l.* or 40*l.* a year, in addition to his half pay. Under existing circumstances, since the alteration of the Appropriation Act in 1820, Sir John Colborne, the Governor of the Upper Province, and Gen. Darling, in New South Wales and Van Diemen's Land, report that the prohibition is injurious. Any other individual can receive his horse allowance and travelling expenses, not being a military officer ; so that in these Colonies you exclude a number of military men from performing civil duties, because they cannot receive the very moderate stipend given to them in aid of their expenses. In the same manner, with regard to barrack-masters ; you cannot get a man of respectability to go out to the West Indies to live upon seven shillings a day ; at least not a person whom the public can safely trust. You can, however, get a captain or a lieutenant of the army to perform these duties, which are military and very useful, if he is allowed, in addition to his civil salary, his half-pay. This description of officer carries with him a reputation, and a commission to lose, which are guarantees that he will be honest in the public service, having stores under his charge. Mr. Huskisson, from being Colonial Secretary, knew the difficulties in which a number of individuals who held civil offices in the colonies were placed, and that it was very desirable to relax the law in that respect, and to allow half-pay officers in the colonies to receive their half-pay with their civil salary. It is clearly more economical and safe to open these offices to half-pay officers. In Ireland, half the officers of the constabulary are half-pay and militia officers. This force is armed, and perform military service to a certain degree ; they are drilled and under military discipline in parades, &c. In short, there are a number of civil situations, both at home and abroad, where the civil salary can be made very moderate and low, if it is allowed to half-pay officers to receive their half-pay with their civil salary. Out of 7,000 half-pay officers, there are about 300 employed in civil offices, or one twenty-third ; of these only eighty-three are employed in offices purely civil, on an average at 150*l.* a year ; the remainder are employed in military departments. The question therefore of expense to the public, is as nothing compared to the policy and good feeling which the relaxation of the law would diffuse throughout the army ; in fact, the employment of half-pay officers is the most economical arrangement.

“ You have also stated it as your opinion, that the Officers of the Army would consider themselves rather ill used if an exception were made in favour of Naval officers, and not in favour of Military officers ?—Certainly ; I consider the two Services completely on a par, as to merit and distinction of service ; though there is this stronger claim on the part of the Army, that the Navy do not purchase their commissions as in the Army. I might cite my own case ; I have served thirty years ; I have sunk nearly 5000*l.* on my commissions, being a younger son. I am in the receipt of military pay of 300*l.* a year. If as a General Officer I were to obtain a regiment, I should think my case an extremely hard one, if because I were acting as Secretary at War I should not be allowed to receive the reward of the past military services of thirty years ; I should consider it an unjust arrangement, being now, after thirty years' public service, barely in the receipt of the interest of the money I have expended. If because an officer has at length arrived at that goal which few can reach, he is to be told, although you have served long and zealously in the army, you, as a General Officer, shall have no military pay, but the same civil salary and no more, as any other individual who

has not served the public a month, I should think such a rule a great hardship.

“ You are aware that if a Military gentleman has been employed for many years of his life in diplomatic services, and receives a pension, if he is afterwards appointed to a civil office, that pension will abate?—Yes; but diplomatic services and military services are very different in their nature: a few facts will show the difference between diplomatic and military services; we are obliged to obey orders; to go, without a murmur or choice, to a colony, however unhealthy; we run great professional risks, exclusive of purchase money, which, if the officer is killed, is lost to his family. I went out to Portugal with fourteen officers of the same standing as myself; at the termination of the war five survived, and of these two had lost limbs, the remainder being killed in action. This is the sort of probation in which a Military man has to serve for thirty or forty years before he obtains a regiment, and which, when once obtained, is, as I maintain, the earnings of a dangerous professional life; and then, is it just to turn round upon him and say, because the diplomatic minister, after ten years’ residence in a foreign capital without exposure, is to have 2000*l.* or 1500*l.* a year, which is to abate if he resumes civil office, we put military officers, who have served thirty-nine years in all quarters of the globe, on the same footing? The two cases are not parallel, and you must (as in the profession of the law) consider a General Officer having a regiment as in possession of the fair earnings of his professional life, and not as the mere holder of a Government pension.

“ I am extremely anxious to urge the claims of half-pay Officers, to the best of my ability, upon the Committee, and, through the Committee, to the House, because in the course of the last year it was my duty to issue some regulations on the subject of the half-pay, by which half-pay for the future cannot be granted as heretofore. By the recent Regulations, no officer can receive half-pay unless he has served on full pay for three years; short of that period, he is to have temporary half-pay for the time he has served on full pay, and if he does not get back to full pay after he has been three years on temporary half-pay, he is to receive no farther half-pay. This regulation will of course prevent many officers from receiving half-pay, who would have done so under former regulations. Other parts of the half-pay regulations are equally severe; and having in the exercise of my public duty been the cause of enacting this strict regulation, I think it my duty, to the utmost of my power, to support their just claims to every kind of indulgence which the Committee can recommend, particularly in cases where they are usefully serving the public in civil offices. If the Committee consent, I should wish these Resolutions, framed in July last, to be inserted on their Minutes, for it is desirable that the half-pay Officers of the Army should know that their interests have been attended to.

[*The three following Resolutions were delivered in:*]

“ 1st. That in the Colonies, all civil offices, without any restriction, should be open to half-pay Officers of the Navy and Army, without any diminution of half-pay.

“ 2nd. That at home all civil offices, in Naval or Military departments, should be open to half-pay officers, without forfeiture of the old rate of half-pay.

“ 3rd. That at home, no half-pay officer should hold any other civil office without forfeiture of his half-pay, unless he should have served on full pay for ten years, in which case he may receive the old rate of half-pay.”

Upon this and other subjects connected with the good of the service, we have ample ground to expatiate; for the present, however, we must content ourselves with having called attention to this important point, and shall touch, ere we conclude, upon some others of a congenial nature, which present themselves.

Leaving out of view the services and sacrifices of British officers of either branch in activity, we must advert to the peculiar difficulties under which those on half-pay are doomed to struggle through their anomalous course. Their income, the source of so much unworthy clamour, is not, in most cases, more than equivalent to the wages of a journeyman of any handicraft trade, and, in the lowest ranks, barely exceeds those of a bricklayer's labourer! Thus, with the education, feelings, and habits of a gentleman, and encumbered, perhaps, with a family, the half-pay officer, in sustaining his position, suffers privations, and is driven to shifts wholly overlooked by the public. In this country, where the factitious prices of the war are still generally maintained by those who deal in the necessaries of life, and who chiefly profit by the remission of taxes, which they intercept and grasp from the consumer, an officer, upon such limited means, may *exist*, but no more. Hence the general emigration of that class to cheaper lands.

While demagogues declaim on the expense of our naval and military force, they forget, or keep out of sight, the incalculable wealth in treasure and territory—in "ships, colonies, and commerce"—acquired and preserved for the nation by their prowess and patient suffering. Trade must sink without the power that buoys and protects it; and the beneficial diffusion of its returns be contracted in proportion as a wise economy in the public expenditure should degenerate into a sterile parsimony, cramping the return by stinting the outlay, and refusing to the active guardians of the national peace and property, the due reward of their important services. The public money, fairly appropriated, usually returns in some shape to the public: for instance, in the case of naval or military stations,—where the most important benefits accrue to the inhabitants and the district, from the stimulating presence and prompt expenditure of the Blue Jackets or the Red.

Having shown the exaggerated value of military pay, when relatively considered, we turn to the prospects of the officer as to a final provision or retirement. Here again we find a strange anomaly. Although, in every respect, the most actively employed, and the most exposed to those agents which destroy or impair existence, the officer is the only class of public servant to whom no certain remuneration is held out through the far vista of years—no remote competence luring him on through arduous service to an easy and honourable retreat. For the veteran officer of the army or navy, there is no defined provision, graduated to length of service, as in the civil departments. Comparatively few can emerge from the subordinate ranks to the highest; in the army, the subaltern, the captain, the field-officer, may toil on for half a century, and then withdraw into some hole to die upon the half-pay of his rank! Should he be so fortunate as to become a general officer, he *may* catch a regiment or a Government; but this is an affair of chance—and even this chance, though his sole prospect of ultimate provision, is a questionable contingency in the eye of the economist. We fear that even the pension for wounds is grudged by the latter: yet by what fiscal valuation is the wounded man to be repaid—or the loss of a limb, hewn from the living body in its prime and promise, to be compensated?

Contrast the condition and prospects of a civil *employé*—a clerk, for instance, in a public office, who enjoys from the outset a salary never inferior to the pay of a subaltern officer—generally far superior—and

after a certain number of years passed in a comfortable occupation, without exposure or serious privation, retires in the prime of life upon a secure and ample income! Where is the relative justice in these cases?

Between the condition and services of the British and the Continental Armies there can exist no parallel. Resembling but slightly in their general constitution, they are distinct in the nature and extent of their services, those of the British Army embracing a field as wide as the globe, with its various climates; and demanding peculiar and proportionate sacrifices. The Army of England shares the independence and rate of living of its nation, and could not exist if not upon a footing of corresponding liberality; yet is it content with a remuneration rather below, as we have shown, the relative scale applicable to other classes; the officer faring, in proportion, worse than the private, whose pay of one shilling a day, though made the most of, and going farther in his case, still barely equals the depressed wages, the inadequacy of which was the pretext of the late rebellion amongst the agricultural labourers.

Of the exemplary conduct of the Army it is, we feel, unnecessary to speak. In the present season of delusion and convulsion, they have preserved Ireland, where the troops are compelled to maintain an attitude of activity, little short of the duties of an actual campaign. They have been rewarded by His Majesty's thanks, those of their immediate Commanders, and the gratitude of the Country. The British Army cannot be taxed with being "behind the age." Directed, in succession, by a late illustrious and lamented Prince, by Wellington, and by Hill, it has rather preceded the vulgar march in the spirit and application of practical improvement: but it has not mistaken alteration for amendment, or insubordination for independence. The defects which may be imputed to its Executive are not, we are convinced, wilful, but are fairly open to remedy. Representing every class of the State, from whose various grades its members are derived, and whose sympathies are hound up with its welfare and its glory, it excels all others in good order. Its officers in general, whose actions as a body are governed by a peculiar sense of honour and of duty, fostered by *Esprit de Corps*, and regulating those nicer springs of conduct which no laws can sway, yield to none at the present day in cultivation of mind and manners, and the laudable desire of improvement; while, upon means touching the *minimum* of decent subsistence in so artificial a state as this, they are enabled by union and good management to maintain in their respective corps an appearance and a board worthy of associated gentlemen.

We have been led into these details, familiar no doubt to our comrades and the public, under the impression that, judging from results, they may have escaped the attention of the Legislature. Need we appeal to every officer of the United Service who may have a seat in Parliament, to rally round his "Order" in its need,—to support its claims? which being founded in justice, recommended by policy, and guaranteed by good faith, there can be no disposition to slight, if fairly and fearlessly urged. To each, however differing upon unprofessional questions, we would emphatically repeat—be united on this—

TUA res agitur.

MILITARY ORGANIZATION OF SWITZERLAND.

THE peculiar geographical situation of Switzerland, placed as a barrier between France and the Italian possessions of the House of Austria, having drawn some of the public attention to the *arming and disarming* of its military force; it may, perhaps, interest the readers of the United Service Journal to become acquainted with the Military Organization of the *only* State in Europe which has no standing army, and yet, in case of need, can in a few days, (I should almost say, hours,) produce, in proportion to the general population, the largest body of men equipped, drilled, and trained to the tactics of war.

One of the first articles of the Constitution of every one of the Swiss Cantons is, that after exception of the clergy and the first functionaries of the State, every Swiss citizen is a soldier. "Tout Suisse est soldat." That liability begins in some of the Swiss States at the age of sixteen, until fifty-five. In some others it begins a few years later and ends at fifty. From the age of twenty to twenty-eight, the citizens are obliged to serve in the Contingents, and are liable to be called out at any moment. After those eight years, they are allowed to withdraw into the Reserve, or Landwehr.

The proportion of the number of armed men in Switzerland is on an average of one for every eight inhabitants, or about 250,000 men out of 2,000,000 souls.*

The above force is divided in three corps, or classes; namely, the two Contingents of regular troops, and the Reserve, or Landwehr.

The first Contingent is composed as much as possible of unmarried men, as above stated, of the age of twenty to twenty-eight.

The second, comprises men of the same age, married or single.

The Landwehr comprises all the citizens, who having served their eight years in the Contingents, claim their discharge from active service.

The basis of repartition amongst the several Cantons fixed in 1814, when the population of Switzerland was computed at about 1,700,000 souls, was two per cent. for each Contingent, making two armies of 33,758 men each, exclusive of the Swiss Federal Staff.

The first Contingent is composed of,		Men.
24	Companies of Artillery	1704
2	Do. Sappers, Miners	142
1	Do. Pontoneers	71
	Waggon-train Corps, (with 1828 horses)	1194
11½	Companies of Cavalry	736
20	Do. Riflemen	2000
	Staff of the Battalions	666
217	Companies, Infantry, (Grenadiers, Voltigeurs, and Centre)	27245
with seventy-two cannon or bowitzers of various calibre.		33758

The second Contingent consists of,		Men.
16	Companies of Artillery	1136
	Waggon-train Corps (with 1141 horses)	717
20	Companies of Riflemen	2000
	Staff of the Battalions	666
219	Companies of Infantry	29239
with forty-eight cannon as above.		33758

* In almost every habitation or cottage, you will find hung up near to the bed, muskets or rifles, according to the number of men capable of bearing arms in the family.

The Cantons which furnish the artillery are obliged to hold to the disposal of the Swiss Federal Council of war, besides the above stated, 120 cannon, thirty pieces and mortars of heavy artillery, twenty pieces of various calibre for replacement in case of accident, making altogether 170 pieces of cannon attached to the two Contingents.

The Landwehr is organized in battalions of infantry, and as most of the Cantons have in readiness more cavalry, artillery, and riflemen, than required by the above table,* any corps of Landwehr called out in case of need would be supported by as much *élite* troops, so as to render it similar to the first or second Contingent.

The Swiss Federal army, when called out by the Swiss Diet, is commanded by officers of the Federal Staff. This corps, to which officers of the cantons are promoted after a certain number of years of service, consists of a certain number of colonels, lieutenant-colonels, captains, lieutenants, &c. &c. of the Staff, belonging to the artillery, engineers, cavalry, and infantry, besides a proper number of commissaries for the administration of the army, and of superior medical officers. A grade in the Swiss Federal Staff ranks one grade higher in the Cantonal service. When the Swiss Diet deems it necessary to call to arms half or more of either of the Contingents, it proceeds to the election of a general-in-chief, a commander in second, and a quarter-master-general. These officers are chosen from the Federal colonels; and from that same Staff are afterwards taken those officers to each of whom is intrusted the command of a division of the army or of a brigade, and in short all the field-officers. That corps wears a peculiar uniform, and the Helvetic cockade, (white and red;) they receive their orders from the general-in-chief, who acts in immediate communication with the Diet or the Federal Directory.

Having already stated the way in which the men are raised, I shall briefly state the manner in which they are armed, equipped, and trained to military tactics.

When the Swiss citizen has attained the age at which he becomes liable to military duties, he becomes also obliged to provide himself with full accoutrements; in the poorer States of Switzerland, he only provides his uniform, and the State furnishes him with the musket, cartridge-box, knapsack, sabre, and capote. In the other cantons, it is a sort of individual tax, (and a heavy one it is,) and the parish is obliged to assist those who have not the means of equipping themselves at their own expense.

In the month of April each year, the captains of the Contingent recruit amongst the young men of the class of the year, a number of men equal to that of those who have finished their time, and gone into the reserve; the artillery has first the choice, after come the grenadier captains, the riflemen officers choose those young men known as good shots; finally, the *voltigeurs* and centre companies are placed in full complement by the remainder. The cavalry is chosen amongst those rich peasants who always have horses, and so is the waggon and artillery train; the proprietor of the horses receiving an indemnity when called in active service.

Various are the means of drilling the troops. In all cantons, there are a certain number of days of exercise in the spring and early part of the summer, besides inspections and reviews. At those exercises, which last from four to six hours each time, the contingents, the reserve, and Landwehr, are all drilled and trained from the first platoon exercises to the grand manoeuvres. The contingents are besides called into camps for three or six weeks, during which they are broken to all military duties, and subject to the most strict

* The Canton de Vaud, which in the Federal army is rated at 5800 for the two Contingents, has always in readiness about 9000 of *élite* troops.

discipline.* The Cadres of several cantons and thirty soldiers by company, are besides called together, under command of Federal officers of the staff, in camps where manoeuvres are performed on a larger scale. Finally, in the larger cantons there is always in the *chef lieu* one or more companies of the contingents doing duty, and relieving one another every six weeks, which time is entirely devoted to drilling and manoeuvring. The officers of the artillery are named and advanced, but after very severe and strict examinations in mathematics and every thing relative to their arm, are obliged every two or three years to go for two months to the Federal School of artillery at Thun, near Berne, where the Cadres of the staff, and of the cavalry and light troops, are also called to the study of theory.

In order to render the re-union of the Swiss army instantaneous, I may say, each company has its own officers in the same district; and its place of rendezvous in a central spot, where others join to form a battalion; a certain number of battalions form a brigade, which has its chief appointed, and a Federal colonel commands a certain number of brigades forming his division. Battalions of infantry, companies of artillery, cavalry, and riflemen, have their own officers of the same canton. Superior and field officers, as above stated, are taken from the Federal staff.

The dress of the troops is not exactly uniform throughout Switzerland. Each canton being an independent and sovereign state, has its cockade, its colours, as well as its own uniform. This latter part of the dress is dark blue throughout Switzerland, the facings varying only, being in some states red, in others light blue. The artillery throughout Switzerland is dark blue and red facings, the cavalry green and red, the riflemen green and black. The head-dress is the Schacko, about the same shape as the present English one. When called out in the Federal army, all officers and soldiers wear on the left arm a piece of scarlet cloth with a small white cross, and the colours, red and white, have a large white cross set transversely.

It is very much talked in Switzerland to have henceforth but one colour, one cockade, and one uniform. Old glorious recollections may render some of the cantons attached to their old colours, but the feeling for unity becoming very prevalent, I believe the time not far distant when such a plan will be adopted.

ONE OF THE FIRST CONTINGENT.

HINTS ON NAVAL AND MILITARY POLICY.

THERE cannot be a question that the disposition of commercial men, to regard taxation principally as a withdrawal of a portion of the capital or revenue of the country, from the support of the productive labour of the people to the unproductive and even wasting expenditure of Government, may be carried so far as to paralyse those energies upon which the safety of the British empire depends. It never can be too frequently or seriously impressed upon the minds of the English people, that neither their commerce, nor their empire,—neither the comfort and security of their homes, nor the extent of their foreign dominion or commerce, can exist longer than the decided and undoubted superiority of their Navy and Army, and the possession of those

* In every town and village there is very frequent firing at the target, with the musket, and chiefly with the rifle, the prizes being given by the governments and by clubs.

foreign citadels or depôts of warlike power, which are necessary to bring their arms to bear with sudden and decisive effect upon any offending power.

The superiority of their Navy must depend not only on that of its *matériel* and composition, of its bravery and science, but also of its numbers and distribution, and its power of appearing in dictatorial force there, wherever its dictation is wanted. That of their Army must consist rather in the perfection of its discipline, instruction, and institutions; its distribution and capability of sudden and efficient increase, rather than its numbers. Both services should be treated honourably and liberally, otherwise they, as well as all public services conducted on a system of meanness and parsimony, will only be more prejudicial than beneficial to the state. Better would it be to throw yourself on the mercies of your enemies, than to protect yourself by defenders who can pay themselves only by robbing and betraying you. The object of every truly patriotic English statesman should be, to ascertain not only how far reduction and economy may be carried in our warlike departments and expenditure, but where they should stop: not how far only, but how far safely, the pruning-knife may be applied to our institutions. Destroy the vitality of any of them, and you impair the vigour and safety of the whole. On these points, as regards the Army and Navy, and Military and Naval policy of the empire, none can be so good or such proper judges as experienced and scientific soldiers and sailors; and, indeed, the general science of war should be understood by every man who ventures to guide the destinies of a great nation.

Sir H. Parnell, in his work on Financial Reform, seems to think that our military establishments in some of our colonies might be put on a more reduced and less expensive footing, and that some of our colonies, we might, indeed, be even better without. Now this may possibly be the case, but to decide that it is so, it is not sufficient to consider merely their exports and their imports, and the expense of keeping them; it is not sufficient to look at them in a commercial point of view; it is also requisite to consider their warlike importance, whether in our hands, or those of an enemy, and to take care not to weaken our hold of those strategic points upon which, in case of war, our operations, either for offence or defence, should turn. In the same spirit he seems to seek the means of economising in our military and naval establishments at home; but in conducting this experimental economy, let him destroy nothing useful; let him not leave the warlike habits, and character, and instruction of our sailors or soldiers, to the accidental operation of supply and demand in what may be termed a blood market; but let him keep every institution upon which these depend, to maintain always defenders of British honour and interests, who are sure and worthy of being feared; let him concentrate, as far as he can beneficially, the scattered and ill connected branches of an administration, which has gradually grown up, perhaps, in rather wild luxuriance, without sufficient method and arrangement, as circumstances have called for them, but let him not, in doing so, impair their powers and diminish their efficiency.

MENTOR.

ON NAVAL TIMBER.

“ Hail, hallowed oaks!—Happy foresters,
 Ye, with your tough and intertisted roots,
 Grasp the firm rocks ye sprung from, and, erect
 In knotty hardihood, still proudly spread
 Your leafy banners 'gainst the tyrannous North,
 Who Roman-like assails you.”

ALTHOUGH the fervent liberalism of the age is making an “ old song ” of the *Mare Clausum*, which so long constituted the boast of these realms, we trust that it will yet be some time before the vital importance of our maritime interests is denied. The British Navy has such urgent claims upon the vigilance of every patriot, as the bulwark of his independence and happiness, that any effort for supporting and improving its strength, lustre, and dignity, must meet with unqualified attention. We, therefore, professing a warm regard for all its aiders and abettors, were well pleased on finding that a treatise on Naval Timber, by Patrick Matthew, of Gourdie Hill, had been launched in this teeming year of legislative innovations.

Mr. Matthew boldly acknowledges but a slight acquaintance with the reputed standard authors on this subject; at the same time he very fairly warns the critic tribe to beware of handling him roughly, lest they expose their own ignorance. This is a heart-of-oak sort of frankness which we highly value; and we relish moreover the characteristic manliness of his style, albeit in turning from analysis to synthesis, he dissects several well-known authorities with such keenness, that were their names suspended over our timber nurseries, they would act as beacons rather than decoys. The terseness of his language, from its fulness and patriotic bearing, needs no apology: “ Some technical or nautical terms,” says he, “ have unavoidably crept into this work; we shall not presume to think any explanation necessary. Britannia would blush *jusqu'au blanc des yeux*, to the tips of her fingers and toes, did she think it were doubted that any of her sons, not doomed to unceasing mechanical labour, were unacquainted with these.”

In thus testifying our hearty approbation of the author, it is strictly in his capacity of a forest-ranger, where he is original, bold, and evidently experienced in all the arcana of the parentage, birth, and education of trees. But we disclaim participation in his ruminations on the law of Nature, or on the outrages committed upon reason and justice by our burthens of hereditary nobility, entailed property, and insane enactments. We consider it a much easier undertaking to decry and pull down, than to replace an overthrown edifice; and, however short our Government may be of that theoretic optimism which can be attained only when mankind shall be perfect, we have long firmly thought, that it has produced more social happiness and freedom by the least objectionable means, than any other state or system, ancient or modern. We are not for permitting every one to legislate; for unlike the horde of newspaper politicians of the day, we hold legislation to require both study and talent, in a much larger proportion than many of our gallery-addressers of the Commons possess. While we readily admit that in substituting intellectual for physical strength, we verify the popular axiom, that “ knowledge is power,” yet we must never

overlook the truth of its semblance being anarchy and destruction. We will not here declare the grounds of our belief that laws make men, as well as men laws—because we hasten to agree with our author in anxiety to preserve the dominion of the seas; and to express our conviction that it, therefore, behoves us to cherish our warlike energies, in order to meet every future aspirant to the possession of the TRIDENT.

Mr. Matthew successively treats of the wood suitable for plank and for timber, and of the best modes of treating British forest-trees, so as to procure straight boards, bends, and crooks, with a decision evidently conferred by a practical knowledge of his subject. The whole of his advice on these heads will be thankfully received by those who properly estimate the value of durability in vessels destined to buffet the ocean; few can predict when the ingenious fabric may succumb, not only to the conflict of war, or to elemental strife, but to its intestine foes, both animal and vegetable. The sailing, the buoyancy, the capacity, are all of direct consequence; but considered both in immediate and remote points of view, durability may be placed above them. We respond with the Evangelist, "enough unto the day is the evil thereof;" and surely, enough unto seamen are the unavoidable dangers of their calling, without superadding that of a treacherous ship. This is a study which our zealous advocate thinks ought to be encouraged by a professor's chair. And this is not all the honour and consideration which he would award, in a country so peculiarly maritime. He holds it disgraceful, while every clodhopper who owns a miserable hovel is carried to the poll, "the brave seamen to whom the rest of the nation is indebted for all they have, and almost all they know," are passed over, and have not even one direct vote in the British Parliament. Nay, more,—he would insist on the heir-apparent being reared in the navy; and in case of the crown devolving on a female, would admit of a dispensation only on condition of her marrying a sailor!

In spite of its having been designated a mischievous and dangerous clamour, all the evidence which has been hitherto collected, goes directly to prove that an alarming diminution of naval timber has taken place, since the survey of the Royal Forests in 1608: and this, notwithstanding great part of the oak consumed in the late wars, was the produce of the plantations made on Evelyn's suggestions, at the restoration. From the same chain of testimony it is also shown that, notwithstanding the recent efforts of spirited individuals to repair the improvidence of their ancestors, there is as yet no prospect of a permanent source of supply. This failure is the most to be lamented in the inadequacy of our growth of oak, as compared with its destruction; for the vast consumption of this durable substance in implements, mills, and machinery,—in docks, vats, parks, mines, and collieries, has, under the recent augmentation of manufactories, more than counterbalanced what has been saved by the introduction of iron knees, tanks, bolts, and other substitutions for which it was largely cut up: nor must we omit on the saving side, the stoppage of the workmen's chips at the dock-yards,—one of the most important of modern reforms, and one for which the country is indebted to a sailor. The scarcity of any commercial material is usually attributed to increase of demand, or lessened

production; but in the present instance both of these causes operate, and the increased demand cannot so readily be followed up by supply, as generally occurs in matters of mere mechanical labour, for the growth of timber bears no proportion to the consumption of it.

To elucidate this position we may mention that the construction of a man-of-war of 74 guns swallows up more than 3000 loads of rough timber, or 2000 oak-trees, a quantity which could not be grown upon less than fifty acres of ground, of a quality fit for producing bread corn; for oak and wheat, the noblest of their tribes, succeed best in good clay soils; for those trees which obtain their nourishment rather from the air and water than from the earth, are commonly shaky and liable to rapid decay. Nor is it the Navy alone which occasions the enormous demand for timber of the largest metings: an East Indiaman of 1200 tons, and sometimes still greater are built, consumes nearly 2000 loads of timber, of one and a half ton each, requiring for her equipment 74 tons of cordage, and 21,000 yards of canvass. In fact, out of a supply of 400,000 loads annually consumed, only 70 or 80,000 are required for our navy.

It is true, that an immense quantity of trees has lately been put in progress for the future wants of the country, but we would still increase it a hundred fold. We strongly advocate a home supply, because the purchase and transit of foreign timber is a serious and continually renewed expense. Nor is expense our only objection: with the exception of the East India and Honduras woods, we have reason to think that so little attention is shown in seasoning, stacking, and exploiting the perishable oak and fir which we procure from abroad, that we are mainly indebted to our imported stock for wet-rot, and for several of the genera of parasitic fungi which infest our ships and occasion the destructive disease called dry-rot. The prevalence of this insidious enemy may also be attributed to the modern custom of felling trees when the sap, or resuscitating principle of vegetable life, is in circulation; a practice arising from the high value of British bark, and the greater facility of stripping it off at that season, for the purposes of tanning. Our English Sylvan-writers, Platt, Pepys, Evelyn, and Capt. Smith, all seem to have been aware of the advantages of winter felling; but the subject has not received that attention from Government which it demands. The French, however, profiting by their suggestions, made a series of experiments, and arrived at the conclusion that oak should be cut down after autumn in northerly winds, with the moon on the wane; thus renewing the injunctions of Cato, Pliny, and Vitruvius. Vegetius is nearly of the same opinion; only for some reason which is but obscurely stated, he says that ship-timber should be felled from the fifteenth to the twenty-third day of the moon. By a royal ordinance of 1669, the time for felling in France was fixed from the 1st of October to the 15th of April; but Napoleon, alarmed at the reports of the effect of the sap fermenting, abridged the season, by ordering that it should take place in the decrease of the moon, from the 1st of November to the 15th of March only.

The advocates for a foreign supply of timber dwell largely upon the excellence of the Malabar forests; and in this we, from experience, cordially join them. But owing to the turgid politics of India, and the

instability of all mundane affairs, we would advise looking at home, even while freely availing ourselves of that profuse resource. The *tectona grandis*, or teak-tree, though designated the "Indian Oak," is quite of a different family,—its immense height and large leaves give it more a majestic aspect, and its timber is even preferable for naval purposes. This is saying much; but as we have had opportunities of personally witnessing its durability under exposure to all varieties of climate, we feel confident in the truth of the assertion. This timber contains in itself an oily protection from putrefaction; and it is destitute of the gallic acid by which oak corrodes iron, and attracts worms,—nor does it nourish the vegetable abortions which create the dry-rot. The variety of it called *puon*, from its mild and straight grain, is very superior for masts, to Jablanaz, Riga, American, or, indeed, any other known wood; the weight is against it for topmasts, but we were in a ship where, on the suggestion of the well-known Jemsatjee Bomanjee, it was tried with success: "If you get it aloft," said he, "it will never go without the lower masts."

We remember seeing at Bombay, a fine country ship, of about 500 tons burthen, which was constructed of teak upwards of forty years before, and was then found to be in perfect condition, and without the slightest weakness or ailment. We ourselves sailed in a frigate built of this material, for four years, in various stations, and upon arduous service, which would have destroyed any of our contract ships, and yet we left her as sound as a new ship. In 1811, the *Dover*, a less substantial teak-ship than the one just alluded to, was driven on Madras beach, and stranded, during a furious gale of wind. So strong was this vessel, that she laid in the overwhelming surf several months, perfectly entire, and in a part where few European ships would have held together for a week; carpenters were then employed at a great expense to break her up, but the work proved so difficult, that they were at last obliged to blow her to pieces with gunpowder.

Amongst the various foreign timbers of which we may avail ourselves as the means of preserving, for future emergency, the valuable oak of our own soil, may be mentioned the mahogany of Honduras, and that vicinity. This tree in the stately majesty of its bearing, and the elegance of its tufts, may be termed the monarch of the forests; and its timber is too well known and appreciated to require further mention, for there is not a cottage in Great Britain but what can boast some article made of it. This unrivalled wood was first used by Sir Walter Raleigh in 1597, in the repair of his ships at Trinidad; but its hardness so teased the workmen, that it was some time before it was generally in request. The *Saul* of Calcutta, and *Sissoe* of Travancore, though inferior to teak, may be produced, for secondary purposes, in great quantity. The lofty cedar, which almost defies insects and time, is to be plentifully procured at Cuba, the Floridas, and the Bermudas; and various trees of compact texture, such as the red and yellow woods of the East, the ebonies of Madagascar, the beef oak of New Holland, &c. are scattered generally over the tropical regions. The *Ilex* of Italy and Dalmatia, the Pines of the Julian Alps, and the Plane-tree of Greece, whose beauty excuses the fatal admiration of Xerxes, afford a second-rate timber, which has been largely applied to our uses. But

it has been found, that in different climates, trees are of a different nature, and therefore not likely to endure so long out of, as in their native countries. Thus in cold regions, the timber is chiefly resinous, as a protection against frosts; in torrid climes, the wood is either protected by closeness of grain, or an oily nature; while those exposed to both extremes, abound with resin and turpentine, and are thus guarded against the transitions incident to their respective stations.

We trust that the time is approaching, when close observation will be drawn towards natural philosophy; and that the Naval and Military Museum may become the means of being practically beneficial to the nation. That periodical meetings for the purpose of discussing professional and scientific questions, or even those of a literary and general interest, are in a high degree favourable to the propagation of useful knowledge, is too accurate a position to admit of doubt. Intellectual enjoyments are the most lasting of those which we can possess; and it is an incontrovertible truth, that these must depend upon the amount of our acquirements. We therefore hail the establishment of this institution as a measure pregnant with happy results to all branches of His Majesty's Services; for while the study of Nature confers the highest gratification on the initiated, the less instructed class becomes unconsciously pleased with the mere externals. In the department of timber, the Museum may be destined to perform much useful service to the public, from the extensive means which it will afford of comparing specimens of the most useful woods of the globe. The experiments on the pressure, resilience, strength, and other properties of this most valuable material, have hitherto afforded such vague results, that the investigations bear more of theoretical plausibility, than of practical utility. Even Buffon's supposed demonstration that the strength of the ligneous fibre is nearly in proportion to the specific gravity, requires a repetition of experiment, because he omitted to ascertain the absolute strength of the timber employed. We would, therefore, call upon the respective officers to collect from the various forests which they may meet with. The specimens should be about a foot in length, and, where they can be obtained, both a longitudinal and transversal cut; with these, careful notes should be given as to whether they are from a branch, trunk, or root; dimensions of the tree; and observations on the cellular or medullary processes. Should the tree be cut, or felled, the age may also be noted, for each of the concentric rings, or layers of wood, is the silent record of a year's growth; where there is much sap, an estimate only will be obtained, but they are easily counted when the tree grows straight, and is in full heart.

Mr. Matthew gives much valuable instruction in rearing timber, as to "bending the tree in the way it should grow." To these directions we would call the attention of those who are planting, because excellent plank can be readily imported, but there are various reasons why futtocks, knees, and compass timbers should be more difficult and expensive. The innovations on ship-building, suggested by Sir Robert Seppings, to supersede the necessity of crooked timber, are not yet generally adopted; and it is more than probable, that the introduction of steam flotilla, in our future wars, will cause an increased demand for crooks. Ribs and bends have been shaped by machinery, and hot

liquids; but it is unlikely that the resilience of such should be equal to the natural bend; and though some dock-yard men will not allow it, we think that the combined heat and moisture must impair elasticity, and weaken that constituent principle of the timber upon which its strength and durability in a great measure depend. Curved timber being always in much greater demand than plank, it is our interest to make a greater proportion of our trees grow in the curves required, for no artificial means, whatever theorists may say, have yet superseded Nature in making them. In order to facilitate this process, close double rows of trees should be planted, with wide spaces between the rows, which will allow of alternate young trees being bent to the right and left, out of the row, either by planting them in a slanting direction, or gradually bending them by tying them down to stakes. And with regard to trees of a few years' more growth, it is recommended that two or four leaders should be left, and these gradually pushed asunder by props from the one to the other, so as to form knees. In short, it is made evident, that provided the forester be instructed in the required curves, he can greatly enhance the value of a forest. Another advantage of planting trees for this purpose in rows is, that the bole, influenced by the direction of the principal roots, will grow elliptical, (its axis major perpendicular to the row,) and thus much waste will be avoided in cutting the timbers, which generally require greater depth than thickness; that is, their greatest breadth must be in the plane of the curve. If the timbers were, moreover, cut into shape on the spot, and the fermenting sap wood cut away, great saving would accrue. It has long been recommended that plank should be sawn out of the round log, because previous squaring, though convenient for transport, reduces the width of the central boards. English plank of short lengths, cut out of young growing timber, is manifestly better than East-country stuff for laying the three strakes of a gun-deck next the sides, because it bears the alternate wet and dry exposure admirably. But for the long planks on the same deck, the foreign growth is preferable, from its admitting better scantlings.

As timber is one of the most important materials which man employs for the promotion of his comforts, its details, from semination to maturity, should be carefully studied. The modifications produced by differences of soil and climate in the same plant, is a difficult but important question; and besides its more tangible utility, an inquiry however slight, into the arcana of vegetable economy, has a beneficial effect upon the feelings and understanding. We shall therefore offer no excuse for here enumerating our most useful forest-trees.

That "father of ships," the British oak, is the first in consideration; and the temperate climate of our country, equally free from the intenser frosts of the north, and the burning heat of the torrid zone, appears to favour its utmost perfection. From this cause, and favourable soil, our "unwedgeable and gnarled" wood possesses the fine qualities of not splintering to shot, resisting strains, and supporting pressure, to a degree that makes it equal to any known timber; and but for the corrosive quality of its gallic acid upon iron, it would be superior to teak: indeed, till the new principles of the "black," or East India built ships, were known, we had held that there was nothing

superior to our "heart-of-oak." Foreign oak is of much quicker growth than English, and is susceptible of being felled, and yielding proper plank, while yet in a sound and vigorous state of vegetation; whereas ours does not arrive at similar dimensions till it has reached, or passed, the full of its strength. In fact, fifty years may suffice for raising a foreign tree to a magnitude which the British one will take nearly a century and a half to accomplish. Owing to this, a deleterious change has been perpetrated in the "timbered state" of the nation; for acorns from the north of Europe and America have been extensively sown by our landed proprietors, for producing trees of a rapid growth, and the spurious produce has been already used under the prevaricating denomination of English oak.

To counteract the evil effect of this "golden-egg" line of impolicy, and insure a never-failing supply, every patriot should devote close attention to the subject: the glory and safety of the country both demand that permanent prosperity in every respect should be secured to the Navy. This can only be effectually done by making it an object of interest for individuals to plant and preserve trees; and to turn away the fuel-cutters, game-keepers, and deer from our crown lands, in order to replace them with persons whose duty it should be to preserve woods, instead of destroying them. The proper choice of soil for planting, the draining of public forests, and the propagation of underwood, are not so widely looked to, as the health and growth of the oaks require; and all timber trees intended for use should be felled so soon as they have attained maturity; for when an oak, or any deciduous tree, is dead at its main-top, the centre of the trunk is sure to be in a state of either actual or incipient decay; and it is not safe, under this clear indication, to use any part of it for purposes where durability or strength are required. The full growth will be accomplished at different periods from semination, according to site and soil; after this period, the decay is in proportion to the time of arriving at perfection, agreeably to the laws of animal as well as vegetable life. Independent of fortuitous circumstances, the period of maturity for the British oak is gained in about a hundred and forty years. From the quality this tree has of striking its roots downwards, it seems to be particularly adapted for hedge rows, and in planting, the adage should be kept in mind,—

"Set them at All-hallow tide and command them to prosper:
Set them at Candlemas and intreat them to grow."

Agreeably to the theory of Sir Humphry Davy, which was obligingly confirmed to us in conversation by that eminent philosopher, the trees most abundant in charcoal and earthy matter, are the most permanent; and those that contain the largest portion of gaseous elements, the most destructible. According to this system, the chesnut and the oak among our own trees are pre-eminent as to durability; and the chesnut affords even rather more carbonaceous matter than the oak, yet the difference is so slight, that it is merely distinguishable in old specimens, in that the pores of the alburnum in the oak are easily discernible, but being more minute in the chesnut, glasses are required to see them. In consequence of the slow decay of the hearts of these

woods, they are supposed to attain an age, under favourable circumstances, little short of a thousand years; but the beech, the ash, and the sycamore,* probably, are limited to less than half that period. Peter Kalm, who visited the forests of North America upwards of eighty years ago, remarked—

“Some trees are more inclined to putrify than others. The tupelo-tree (*nyssa*), the tulip-tree (*liriodendron*), and the sweet gum-tree (*liquid amber*), became rotten in a short time. The hiccory did not take much time, and the black oak fell sooner to pieces than the white oak, but this was owing to circumstances. If the bark remained on the wood, it was for the greatest part rotten, and entirely eaten by worms within, in the space of six, eight, or ten years, so that nothing was to be found but a reddish brown dust. But if the bark was taken off, they would often lie twenty years before they were entirely rotten. The suddenness of a tree's growth, the bigness of its pores, and the frequent changes of heat and wet in summer, cause it to rot sooner. To this it must be added, that all sorts of insects make holes into the stems of the fallen trees, and by that means the moisture and the air get into the tree, which must of course forward putrefaction. Many of the trees here have deciduous or annual leaves. Many of them begin to rot whilst they are yet standing and blooming. This forms the hollow trees, in which many animals make their nests and places of refuge.”

Next to oak, the timber which we would fain see more largely cultivated is the chesnut. This noble and useful tree abounded formerly in the woods and chaces around London; and the roofs of Westminster Hall and King's Chapel at Cambridge, are sufficient proofs of its durability; indeed, the beams of the latter appear so new, that on making inquiry as to their age, we were surprised by the reply that they were cut in Essex, from the estates of the College, when the structure was erected. This timber should be grown in a suitable soil and climate, that the albumen vessels may not relinquish their office too soon, and render the wood shaky, by unequal sbrinking. This effect is known, by observing when the tree is cut down, what proportion the rings of sap-wood bear to those of heart. From the downward striking of the roots, this tree appears adapted for loamy soils; but it can also be reared on the sides of hills to advantage; and the opinion has been received through all ages, that though the low lands produce the state-liest trees, the strongest timber is grown in drier and more exposed situations. In the former, the increased growth is accompanied by an expansion of the vegetable fibre, by which the annual rings are softened, and become more permeable by air, water, and heat.

The mention of chesnut naturally reminds us of the walnut, as they may be planted together with benefit; and although the brittleness of its wood incapacitates it for “naval timber,” the service it is of, in its universal employment for fire-arms, calls forth our thanks for the numerous plantations which we observe are now replacing the heavy demands of the late wars.

* We are here merely citing a general rule: we have met with timber of much more advanced ages than any instanced to us by Sir Humphrey. In Egypt we procured boards of sycamore, in an apparently fresh state, which may have been cut more than 3000 years ago! And these were without the thick coating of painted plaster with which the wooden idols and mummy cases are covered.

The beech is a magnificent tree of rapid growth, and being of a hardy nature, is readily reared from its mast, in strong grounds, unfit for other cultivation. The yellow beech, being of a fine grain, and not apt to rend, is excellent for plank, if well managed after cutting down: but a few months in the ground may render a log of it in the bark useless. It therefore requires either to be speedily dried, or else kept altogether in water; nor is the sap-wood easily distinguished from the mature, being of the same colour.

There are several species of elm common to this country, but they may be chiefly divided into the *montana* or broad-leaved, and the *campestres* or narrow-leaved. The former being all heart, is best adapted for naval purposes, as keel pieces, floor timbers, and bottom plank, for which it is highly capable by its strength and toughness; but it quickly decays above water. The second is valuable for forming dead eyes, and block shells, for which its elasticity and indisposition to rend, especially suit it.

The ash braves the wintry winds better than the elm, when it enjoys a sufficient depth of soil; its timber is largely used, but in the navy principally for sweeps, oars, and handspikes.

The sycamore, or more properly the maple, grows to a large size, and its soft white wood is useful for turning; it grows in light dry soils, near the sea-shore, where it resists both the spray and the winds, and is easily propagated from its keys.

The alder is useful for piles, pumps, sluices, and all works intended to be constantly under water, as it has there the property of hardening.

The quick-heap, or service-tree, with several others, affords woods of a fine but soft grain, which are useful in detail.

The willow is a very numerous family in Great Britain, as may be seen by the magnificent work recently printed by the Duke of Bedford, in which is a botanical description of no less than 160 of the genus *Salix*; a tribe which the late Sir James Smith calls "vast, important, and most natural." The largest is the *Russelliana*, of which the one called Johnson's willow, near Lichfield, was thirteen feet in girth, and sixty in height, previous to its destruction in 1829. From its easy culture and rapid growth, it is a profitable tree, being largely used in various important handicrafts; it affords the best charcoal for making gunpowder: and the quantity of charcoal yielded by a wood, is held to be a tolerably accurate indication of its durability. The red willow is employed in the construction of mill water-wheels, and other purposes where tough, light, and durable boarding is required; or where there is exposure to blows and friction. Of its naval properties Mr. Matthew says,—

"The use of red willows, as timbers of vessels, has been of long standing in this part of Scotland, and has proved its long endurance and excellent adaptation. By reason of its lightness, pliancy, elasticity, and toughness, it is, we think, the best, without exception, for the formation of small, fast-sailing war-vessels. We are pretty certain that our Navy Board would not have cause to regret trial of it in a long, low, sharp schooner, of sufficient breadth to stand up under great press of sail, moulded as much as possible to combine great stability with small resistance from the water, and when in quick motion to be buoyant—especially not to dip forward—provided it

could be procured not too old, and free from rot, large knots, and cross grain; a very little attention in the cultivation would afford it of the finest bends, and clean and fresh. Our Navy Board have received some slight teaching from Transatlantic brethren, of the superior sailing of fir-constructed vessels, to those of oak, the result of their superior lightness, pliancy, and elasticity.

"The writer of this has also had experience of two vessels, one of oak and the other of larch, on the same voyages, at the same time, and has found the latter superior in sailing to the former, in a degree greater than the difference of build could account for. From the superior elasticity and lightness of the willow, even to larch, the lightest and most elastic of the fir tribe, we should expect that vessels of it would outstrip those of fir, at least of Scots or red pine, as much as the latter do those of oak; and that, from this greater elasticity and lightness, they would move through the water, yielding to the resistance and percussions of the waves, compared to those of oak, as a thing of life to a dead block. For vessel-timbers, this wood requires to be used alone; as, when mixed with other kinds less pliant or elastic, the latter have to withstand nearly all the impetus or strain, and are thence liable to be broken, or, from the vessel yielding more at one place than another, she is apt to strain and become leaky."

Of another tree, which seems scarcely to claim forest rank, the author says,—

"The laburnum (*Cytiscus*) is the most valuable timber this country produces. It is equally deep in colour, and takes as fine a polish as rosewood, having, also, something slightly pellucid in the polished surface. From its extreme hardness, it is much better adapted for use than mahogany, not being indented or injured by blows or rough treatment. We are acquainted with no other timber of home produce so little liable to decay. The large-leaved variety, in rich warm soils, acquires a diameter of a foot or a foot and a half, and grows rapidly till it fall into seed bearing. Its usual very stunted growth is partly owing to less valuable faster-growing trees overtopping it. Were it planted alone, and trained to proper curve, it might be profitably reared for the upper timbers (the part where decay commences) of small vessels: it has the thinnest covering of sap wood of any of our timber trees. The extreme beauty and richness of its clustered depending blossoms is a considerable injury to its growth, as it is often broken and despoiled of the branches on this account."

The utility and treatment of the whole tribe of pines are so duly appreciated, that we need scarcely dwell upon them, except to mention that the pitch pine, that gigantic lord of American wilds, affords the best known planking for ships' bottoms. To the adhesive quality of this timber, the safety of that fine ship the Gibraltar, of 80 guns, has been attributed: having struck upon a rock in the Mediterranean, she was found to have brought home a fragment of it, of about ten tons weight, sticking in her garboard strake.

Mr. Matthew treats the "genus pinus" at some length, and notices the endless varieties depending upon climate, soil, and exposure.

(To be concluded in our next Number.)

RECOLLECTIONS OF A VISIT TO WARSAW IN 1828.

BY A FIELD OFFICER.

SUCH universal interest is shown in the present day for the fate of that nation whose capital I visited in the year 1828, that I have thought a record of the various circumstances which came under my own immediate observation upon that occasion, may be acceptable to the readers of the United Service Journal.

I have seen the Notes on Warsaw by H. D. J. taken in 1823, and inserted in the April Number of this Journal, and I beg to assure H. D. J. that the same marked and condescending attention which he received from His Imperial Highness the Grand Duke Constantine at that time, was continued to myself and fellow-travellers in the same handsome and flattering manner on the occasion of our visit in 1828.

In the month of July of that year, myself and a party of officers after leaving Moscow, and travelling for the space of twelve days and nights, arrived at Warsaw. On the journey our carriages had been so much injured by the furious driving, which is often the case in that country, that at Smolensko we were detained a considerable time, in order to afford them the necessary repairs. Each carriage was drawn by four horses abreast, driven by a coachman in a somewhat singular costume, his dress being composed of a sheep-skin, the wool turned inwards, for a coat, with blue-striped or white cotton trowsers, his breast covered with a long and shaggy beard, and his hair cut very short behind, and generally clean shaved on the upper part of the back of the neck; a black hat, broad at the top, with broad band and large steel buckle, which he invariably takes off to every person he meets on the road. Thus equipped, he takes his place on the box of the carriage, and, generally speaking, drives well and with great velocity, more especially on descending or ascending a hill. The pace on descending is tolerably moderate at first, but about half-way down, the horses are pressed into a gallop, their pace increases, and they pass the Corduroy Bridge, which is generally over some little water-course, at the bottom, at their greatest speed; this velocity is continued up the hill in front as far as their strength will carry them, being urged on all the time by the cracking of the whip and the animated cheering of the driver. After resting a short time, the process is repeated. They do not consider their horses much: on one occasion we travelled in the night with the same horses a distance of fifty-one English miles, which was performed in little more than five hours and a half. There is something in the vigorous charge, if I may so call it, by four horses extremely exciting. The strained muscle, the swelled and throbbing vein, the eye of fire and flowing mane have a beautiful effect when thus abreast. The animating cheers of the driver are answered by the quick-drawn breath and increased exertion on the part of the noble animals, and when thus at full speed, with their distended nostrils and varied attitudes, they have a most classical and beautiful appearance, and, in fact, are an exquisite living model of the celebrated works of the ancients. The horses themselves are many of them of great beauty, of Arabian cast, and an eye of fire. The *near* and *off* horses are trained to have the head inclined outwards and drawn towards the ground, so that the varied action of the four, arising from their different positions, causes them always to be grouped in a very picturesque

style. The usual rate of travelling, with four horses, is from fourteen to sixteen versts per hour, for the small sum of not more than three-pence sterling per verst, which includes the usual fee given to the coachman; offer but an extra ruble to him, however, and he will drive you at any rate, even to the death of a horse, "with the harness on his back;" but such excessive speed is at times dangerous, and liable to be attended with inconvenience, as the postmaster at each station has the power of detaining you, or making you pay for a horse if he is in danger from over-driving.

We arrived at Warsaw about four o'clock in the afternoon, and drove to the Hotel de Vilna. The arrival, I believe, of all travellers, is immediately reported to the Governor and Grand Duke, and in the evening an aid-de-camp from His Imperial Highness waited upon us, with an invitation to attend a review the next morning at four o'clock, of the Russian and Polish troops, which were then encamped a few miles from the town. The invitation was accompanied by an offer of horses for the field, with an intimation that any style of dress would be suitable for the occasion. We all felt very much gratified by this early mark of attention, more particularly by the very polite and gentlemanly manner in which it was communicated to us by the aid-de-camp. The reader can well imagine, that after travelling for twelve days and nights in the months of July and August, we found ourselves greatly fatigued on our arrival, more especially as we found no beds on the road, except at Smolensko, with little to eat but what we took with us from Moscow, which consisted of some tea, dried tongues, and portable soup. In the villages, however, we found eggs, milk, and butter, but the black bread the horses themselves would scarcely touch.

In this state of bodily fatigue, a second invitation was very soon brought to us by the aid-de-camp of the Governor of Warsaw, requesting that he might be allowed to present us to His Imperial Highness at Belvidera Palace the next morning at three o'clock; at the same time accompanying the invitation by a request that we should take our seats in his carriage to convey us there, and also to the field afterwards. Under the circumstances of our journey, the idea of rising at two o'clock the next morning was not a very agreeable one, and I am sorry to say that two of the party failed in their endeavours to accomplish the undertaking, by which they lost the honour of the presentation, and as fine a review of 45,000 men as ever was witnessed by any military men. Some forty or fifty officers of rank in the Russian and Polish services attended the levee. On our arrival at Belvidera we passed through the hall of the palace up stairs, and in an adjoining room to the one we all assembled in, coffee was served to a few. Soon after we descended again into the hall, when I was directed to take my station immediately to the right of the door through which the Grand Duke was to enter. My travelling companion was placed next to me, and from our right the remainder of those present formed a circle round the hall to the door again. His Imperial Highness on entering commenced with myself, and in a very polite and condescending manner, made many inquiries as to where I had served, my regiments, where I had come from, and how I liked Russia? appearing pleased, when in answering him, I informed him that I had had the honour of serving under the "Great Captain" in the Peninsula. Questions much to the same effect were also addressed to my companion, when the Duke pro-

ceeded round the room, addressing every one in turn in the same agreeable and unaffected manner. There was a Major in the French service present, and I could not help remarking that his reception appeared not very cordial; indeed, I am not sure whether he had an invitation to the review, for I never saw him after. At the conclusion of the levee we drove to the camp, where we found horses ready provided and accoutred for us. I was informed by the Governor that the Grand Duke would like me to keep near him in the field during the review, and we both galloped up to the ground where His Highness then was. Orders were instantly given, and operations commenced with the whole *corps d'armée*, which consisted of 45,000 Russian and Polish infantry and foot artillery, — those very men who are now crossing their bayonets with each other. His Imperial Highness directed all the movements himself: the plan was an attack of the whole army on a supposed enemy, and the ground on which it took place, was that on which a great battle had formerly been fought between the Swedes and Poles; indeed, even now there are many traces of the old works remaining. At the conclusion, some of those works were carried by the troops at the point of the bayonet, and with the loud cheering of the soldiers the review finished. The officers on the Grand Duke's staff informed me that they were not made acquainted with any of the movements before they arrived in the field, and that this was invariably the case; from the extent of the lines the Staff on that day, I am sure, had no sinecure of it. The Grand Duke did me the honour to point out every thing worthy of notice during the whole review, and appeared very anxious to know what impression it made upon me, for in my conversations with others, he invariably made inquiry of them what I had been saying. On one occasion, in consequence of my having made some observation about the French mode of putting on a knapsack, he asked me if I had seen his, and immediately sent Gen. F—— to halt a Polish regiment of the Guards, then marching in line, one thousand strong, and said, "You shall see how soon my men can *undress*," alluding to the facility with which the men could pile their arms, take off and put on their knapsacks. I was requested to ride up and examine them, which I did, and dismounting, went through the ranks of a company or two; the officers of those companies attended me with Gen. F——, explaining and pointing out every thing for my notice.

I had an opportunity of seeing a great deal of this army both on this and the following days, not only their movements under arms, but their interior economy. 45,000 men together is at all times a magnificent sight, and I think on this occasion was as near perfection as it could be. I must say I have seldom seen finer men, or men move better under arms; they are also very well appointed. It was a sight, indeed, not to be surpassed in beauty with that number of men. The movements were chiefly in advance, with clouds of skirmishers; many very beautiful squares were formed of two battalions, in the same manner they are formed against the attacks of the Turkish cavalry! So formidable are the Turkish cavalry, that a square of 2000 thus formed, twelve deep, is not secure against them without a couple of field-pieces at the angles. This was particularly pointed out, and I was informed by a general officer, that in the former war with Turkey, he witnessed a square of 2000 men thus formed, but without the protection of the

guns, slaughtered to a man. And, if I recollect rightly, something of the same nature took place near Varna in the late war, and since I was at Warsaw.

The movements and manœuvring over, they marched past in close column. I was placed immediately on the right of the Grand Duke, who occasionally with his hand resting on my leg or the saddle, pointed out to my notice any particular regiment or officer that had been distinguished during the war. To many regiments in passing, he repeated the word *Ka-ra-shaw*, in a tone of satisfaction at what they had done, which was invariably replied to by the soldiers. I had the honour of taking off my hat to the colours of each regiment as they passed, and from the situation I was in, and the marked attention towards me by the Grand Duke, I fancied myself half a field-marshal before the day was over. The review altogether occupied about four hours and a half, and at the conclusion I was informed that directions had been given for everything to be shown us in Warsaw. We took our leave, and when we were about driving off in our carriage, a message was brought from the Grand Duke to say, that a review of his cavalry would take place two days after, accompanied by an invitation for us to attend it. I was afterwards informed, that this cavalry review was suddenly ordered, and on our account, for which I understood we got any thing but the "blessings" of the cavalry officers. It was not to have taken place until after the return of the Grand Duke from his tour of inspection along the Frontier, which would have been about six weeks from that time. I afterwards recollected having made some observations during the day about the French cavalry, which I saw at the review at St. Omer the year previous. The Grand Duke immediately asked me, if I had seen his, which I answered in the negative. It was this circumstance, I have no doubt, which caused the order to be issued.

Directions were given that we should be shown the interior of the cavalry barracks the following day, when we found them in no little bustle preparing for the review. The stables are excellent, much more lofty than our own, everything regular and in good order, but the men appeared a little crowded in their barracks, and the rooms were generally very small.

The review of 7000 cavalry and horse-artillery took place on the following day as ordered, and the Grand Duke again directed the whole in person as before. I was again mounted on my fine old charger, whose martial bearing the day before pleased me much. It was politely offered, in case I did not approve of him upon the former occasion, to provide me with another; but I had discovered that the sound of the trumpet and the roar of the cannon had been his music all his life; I therefore mounted him again upon this occasion with a great deal of pleasure. There was a rocket-brigade out, mounted on carriages, which at a little distance had all the appearance of being horse-artillery. The Grand Duke informed me, that he ordered them out because they were English, "Congreve, Congreve," meaning the rockets were of English invention. I had had an opportunity before of witnessing a trial of the Congreve rockets, not only in the field, but at St. Jean de Luz, before His Grace the Duke of Wellington; and although I had formed a very humble opinion of them, I still did not feel the compliment the less on the part of the Grand Duke. The cavalry horses are very good, and they manœuvred beautifully; the Polish lancers are mounted on horses near sixteen hands high; the

horse-artillery were also perfect, if it is possible to be so; their movements were rapid, and the horses very beautiful in figure with great strength, and every requisite for the service they are intended for: these horses I understood to be chiefly from Russia. The review was concluded by our taking up a particular position to witness a general charge of the whole of the cavalry in line. Now, the united physical force of 7000 men and their horses, acting together at the same moment, and upon one general impulse, is a sight which most men never see—few men see but once—but which all men should see; it is the velocity of lightning, united with the rush of a whirlwind, beautiful in sight and terrible in power. The whole of the line was preserved entire, with one exception, the flanks of a regiment of Polish lancers pressed too much before its centre, and forced it quite out of the line to the rear: the circumstance appeared not to please the Grand Duke. The regiments after this all passed in review, and being again placed on the right hand of the Grand Duke, he as before drew my attention to particular regiments and individuals in passing, as thus—"That officer is a Mahometan captain," "that is young Prince Lieven," "the regiment now passing distinguished itself on such an occasion." In his turn, a young man of a very good figure appeared; "that," observed the Grand Duke, "is an American Yankee Doodle," Yankee Doodle being added in a facetious tone. The observation not only made me smile, but also the American, Mr. Munro, and his men too, for it was said in so loud a tone of voice that they all heard it. This young man had the good fortune to be very much in favour with the Duke, generally dining at his table, and I believe has since been appointed to the situation of aid-de-camp. The Duke rode up to a very fine-looking cavalry non-commissioned officer, "hearing his honours thicken upon him," having several stars and orders on his breast; I think he was keeping the ground. He familiarly gave him a slap on the thigh, then took his ear and gave it a gentle pull, at the same time exclaiming, "brave soldat," &c. &c. It appears that this man had been particularly distinguished for his gallantry during the retreat of the French army from Moscow.

We were shown during our stay every thing that was worth seeing, both civil and military, and were in excellent hands, being consigned to the protection of no less a personage than Colonel the Baron —, Aid-de-camp to His Imperial Highness, and Chief of Police of Warsaw.

The military bathing establishment is well worthy of notice. An order was sent to prepare it for our visit, and a variety of evolutions were performed with boats, pontoons, &c. &c. The mode of teaching the young men to swim was shown and explained; it is excellent, and many of the performances were most expert; several of them turned two or three somersets before reaching the water, from a height of twenty or thirty feet.

All strangers are very closely watched both in Russia and Poland, as well as other parts of the Continent, and in Warsaw they have no hesitation at all in transmitting you your letters from the post office open. There was a gentleman in Warsaw, during the time of our visit, who received a letter from a young Oxonian friend. The University wag was aware that the letter would, as a matter of course, be opened, and on that account, by way of a joke, he couched it in true college slang. They would not have found much difficulty in deciphering Greek or Latin, but he compiled such a string of unintelligible,

untranslatable phrases, that the devil himself could not make head or tail of it. At the post office they were sadly puzzled, for they could not understand a word of it. I think it was the best composed thing of the sort I ever saw. I much fear our old friend the Baron is no more, as I think I saw his name amongst the list of those killed during the late insurrection in Warsaw. He spoke in high terms of both Paris and London, having accompanied the royal visitors to both at the conclusion of the war. He was one of the party at the Pulteney Hotel, and declared to me that they never knew what living was either before or since their visit to London.

I think that the Russians may have a little the advantage of the Poles in size, but the latter are by far the more intelligent men. This distinction is very remarkable in the countenance, which I particularly observed on one occasion, when riding down in front of two brigades, one of Russians and another of Poles next to them, both of the guard. I was present occasionally during the performance of the evening service at sun-set, and found it rather an imposing and interesting sight. The priest stands in front of each brigade, the soldiers in great coats and forage caps, occasionally bow the head and cross themselves, seemingly devoutly attentive to the ceremony.

The beautiful and amiable Princess Lowicz was universally praised for the excellence of her private character; at that time the Grand Duke and the Princess led a very retired life at the Palace of Belvidera; the Duke was generally much occupied with military affairs. Warsaw and Poland generally had much improved under his government, and all the institutions of the country were in the best possible state, and the cultivation in as good a state as could be desired. The peasantry appeared to me to be very happy, and to have every comfort consistent with their situation. The public roads were spacious and in the best possible order, more especially that from Brestleatowski to Warsaw and Breslaw, which is as fine a piece of macadamized road as can be seen. I only except that from Petersburg to Moscow.

In conclusion I must here observe, that in the private society of Warsaw, which consisted of course of a mixture of Russians and Poles, I found politeness, hospitality, and a considerable degree of beauty. The very marked attention shown me by His Imperial Highness the Grand Duke, and the scenes I had witnessed during my stay, had made such a forcible impression on my mind, that I have ever since recurred to the recollection of them with the most unfeigned pleasure; but, alas! what a change has come over that unhappy land since the time I speak of. The banner of defiance has been raised, and what farther horrors may be in store for her time alone can show. The profession of a soldier does not steel his heart against the common feelings of humanity; I may, therefore, be allowed to express my regret at the horrible state of anarchy and confusion which at present reigns to the destruction of every thing desirable in that beautiful country,—where the pestilential breath of disease withers up the athletic form of the warrior whom the sword spares; where the humble peasant, driven from his home by the ghastly and fierce visage of the demon of destruction, returns but to find his once peaceful cottage a mass of blackened ruins, a scene of desolation and despair, standing as a melancholy monument of his blighted hopes, and of the bloodstained progress of the furies of war.

H.

A RECENT VISIT TO SEVERAL OF THE
POLYNESIAN ISLANDS.

BY GEORGE BENNETT, MEMBER OF THE ROYAL COLLEGE OF SURGEONS
IN LONDON, &c. &c.

THE ISLAND OF RÔTUMA.*

ON visiting the king, who resided at the village of Fangwot, we found him a well-formed and handsome man, apparently about thirty years of age; the upper part of his body was thickly covered with the Rang, or paint of turmeric and oil, which had been recently laid on in honour of the visit from the strangers. There was somewhat of novelty, but little of "regal magnificence" in our reception. In the open air, under the wide-spreading branches of their favourite Fifau, (*Callophyllum Inophyllum*.) sat his Majesty squatted on the ground, and surrounded by a crowd of his subjects. The introduction was equally unostentatious; one of the natives who had accompanied us from the ship, pointing towards him, said, in tolerably pronounced English, "That the king." His Majesty not being himself acquainted with our language, one of his attendants, who spoke it with considerable fluency, acted as interpreter. After some common-place questions, such as where the ship came from, where bound to, what provisions we stood in need of, &c., we adjourned to the royal habitation, which differed in no respect from the other native houses. Yams, bread-fruit, and fish, wrapped in the plantain leaves in which they had been cooked, were here placed before us, with coco-nut water for our beverage; plantain leaves serving also as plates. But before we had time to do full justice to the regal repast, such a concourse of natives had surrounded and entered the dwelling, and occasioned such inconvenience from the heat, that we were glad to make good our retreat, and put an end to the interview.

The chiefs are elected kings in rotation, and the royal office is held for six months, but by the consent of the other chiefs, it may be retained by the same chief for two or three years. The royal title is Sho: the king to whom we had been introduced, as a chief, is named Mora. We had an interview also with the former king, named Riemko; he is a chief of high rank, and a very intelligent man: he spoke the English language with much correctness. Being naturally of an inquisitive disposition, and possessing an exceedingly retentive memory, he had acquired much information; this he displayed by detailing to us many facts connected with the histories of Napoleon Buonaparte, Wellington, &c., which had been related to him by various European visitors, and which he appeared to retain to the most minute particulars. He surprised us not a little by inquiring if we resided in "Russell-square, London?"

A stranger, on visiting this small island, scarcely known to Europeans, is quite astonished at hearing the English language spoken by so many of the natives, and to perceive them all so anxious to acquire a knowledge of it. I was frequently amused by hearing these naked savages attempt a conversation among themselves in my own language.

* Continued from page 202.

A blind lad, who came on board, "not to see the ship but to feel her," as he expressed himself, spoke English fluently. In conversation he asked me, "What the name of your ship's owner?" "Got many ships?" Then as a display of the knowledge he had acquired, either from the European seamen resident on the island or during his occasional visits to the shipping, he said, "You steer by a compass, and take the sun with a quadrant—and have charts—and that is the way you go to different places." He also repeated to me the days of the week, and months of the year with great accuracy. He had been blind from a child, but from what cause I could not ascertain.

There is a pleasing and innocent custom among the females of this, as well as of the other Polynesian islands I visited, of decorating themselves with flowers, by placing them either singly in the hair, and behind and in the lobes of the ears, or by forming them into elegant necklaces and head-wreaths; and in their arrangement they display admirable ingenuity and taste. Their favourites are the Fifau, Kowa, (*Hibiscus rosa chinensis*.) Pandanus odoratissimus, the Mouscoi,* (*Uvaria* sp.) and the Gardenia; but they use numerous other species, selected either for their beauty or fragrance. I never observed among them the Eastern custom of communicating their feelings or affection through the medium of a bouquet.

The dress of both males and females consists simply of an Apé or mat, worn round the waist, descending to the ankles, the upper part of the body being left exposed. The fishing, or common dresses of the latter, are made from strips of the plantain-leaf, or those of the Rang or turmeric plant, which are dried and bleached in the sun, and when worn in a bundle round the waist, descend a short distance below the knee. Their marriage ceremony is performed by the parties standing in the water by the sea-side up to the waist with mats around them, they are there smeared over with the rang or paint of turmeric and oil; † they then come out of the water, are arrayed in new mats, a feast is given, and thus the ceremony concludes. Polygamy is permitted here, as in most of the other Polynesian islands. Previous to marriage, there is no restriction placed on the female; her character does not suffer by a deviation from chastity, nor does it militate against her being subsequently married; but after having entered into this state, they are considered faithful—most probably from the effects of fear.

In the cleared spaces usually left in the centre of their villages, and which are swept every morning and evening, are either a clump of Toa-trees, (*Casuarina equisetifolia*.) (the wood of which is highly valued by them, and from its hardness and durability is named by Europeans iron-wood,) or their favourite fifau. Here the natives, resorting to enjoy "the gay and festive hour" in the cool of the evening, display their graceful movements in the slow dance, or cause the air to rever-

* The fragrance of the flowers of this shrub surpasses all the others; even when dried the odour is preserved for years, and some now in my possession have not in the slightest degree lost their fragrance, although they have been preserved upwards of twelve months in a dried state. The natives use them also for scenting their coco-nut oil. The shrub is found in hilly situations.

† This smearing of paint seems to be considered essential in all their forms and ceremonies; it is practised on the meeting and at the parting of friends, as well as in the marriage ceremony.

berate with their yells when the dance is that of war. The natives are cleanly both in their persons and habits; the custom of rubbing their bodies with scented coco-nut oil, as well as the aromatic smell of the turmeric, gives to them an agreeable odour. They are particularly cleanly in their meals, and expressed great disgust at the dirty habits of the Sandwich islanders, who touched there in the unfortunate brig *Temeamea*, under the command of Governor Boki.* As articles of trade, they are partial to beads of large size and showy colours; also axes, chisels, whales' teeth, fish-hooks, small looking-glasses, &c. The females are remarkably fond of beads, in the arrangement of which they display as much taste as in their necklaces of flowers. I was requested one morning to visit a chief of high rank, for the purpose of rendering him my professional assistance, as he had been long suffering from illness. I readily acceded to the request, and after a sultry walk arrived at his residence at a village named Shoar. This chief, who was named Moeta, had long been suffering from rheumatic affections of the joints; he pointed out to me the scars where the native remedy of burning had been resorted to, but no benefit had resulted from it. I prescribed for him, and he inquired of me what diet he should use, &c. He afterwards presented me with a fine mat of the island, and on my refusing the proffered gift, he seemed displeased, and said, "that it was the custom of the country;" I consequently took it: this was the only instance during my visit to any of the Polynesian Islands, that a gift was ever tendered to me for professional services. Dysentery is one of the most prevailing diseases among them, from which numbers annually perish, and from the benefit they have derived from European medicines, I had numerous applicants. That a medical practitioner would be highly esteemed by them, was exemplified by the *high offers made and inducements held out to me* by a chief named Ufangnot, of the district of Saffe, who thus expressed himself in tolerably good English, "You stay at Rótuma, make people well, as too many people die, and you have made some well, and know how to cure all people, you will have plenty wife, plenty yam and pig, plenty land, and be all the same as one king." Far superior in style was a wish expressed for my remaining at Eimeo, one of the Society Islands for a similar reason, by a chief named Mare, when I visited it in October 1829, of which the following is a literal translation from the beautifully figurative language employed by the Polynesian natives. "You, Curer of Diseases, stay on this land, that it may not be consumed by death, but that it may go with an upright head." On my asking him, what advantage I should derive from complying? He replied, "You shall have what the land produces; we can give you no more, nor that which we have not." Nature, among these people, is the chief physician. Burning and cutting are the remedies principally used for all their diseases. Ophthalmia is prevalent among those who reside in the vicinity of the beach; which may readily be attributed to the reflection from the sand.

* The *Temeamea*, Sandwich Island brig-of-war, with Boki and between two or three hundred natives of the Sandwich Islands, sailed from Oahu for Erromanga on the 5th of December 1829: they touched at the island of Rótuma, but had not afterwards been heard of. From portions of wreck having been picked up about the New Hebrides Group, it is suspected that she was either wrecked, or blown up by gunpowder, a quantity of which was placed between decks without any precaution.

I observed also the purulent ophthalmia common among the infants; but no inducement (from what reason I could never ascertain) could make the native women wash their children's eyes. The lotions which I frequently gave them for this purpose were seldom or never used, but all internal remedies they took readily and with confidence.

On a hill not far distant inland from the village of Shoar, I visited the burial-place of the kings, named by the natives Shishoul; the path leading to it was delightfully shaded by a variety of trees; this burial-place of the regal personages possessed nothing remarkable, either for beauty of scenery or of construction. It was simply a slightly elevated mound inclosed with stones; over the graves were placed large coral stones, marking the situations of each; some parts of the mound were planted with the variety of Chi, (*Dracæna terminalis*), named Chinilal by the natives, the leaves of which are highly ornamental, being of a beautiful dark crimson colour, and which it is considered the prerogative of the kings only to wear as a girdle around the waist. At a short distance, it was densely surrounded by bread-fruit and other trees. The ordinary places of burial are attached to the villages, and have no unapt resemblance to European churchyards; they are mounds, built round with stones, and the graves are covered by large coral stones, some laid flat over the graves, and others elevated similar to our tomb-stones.* The dead are simply wrapped in a mat when buried. The beautiful drooping Toa, (*Casuarina equisetifolia*), as corresponding with the situation, and other shrubs, are usually planted over and around these mounds. I observed also high mounds of stones, which must have required great labour in their erection; on each a hut was built, and on inquiry I was informed that these were the burial-places of particular chiefs.

Four kinds of mats are manufactured on the island. The first is named Ehap, and is the common sleeping mat; it is made from the older leaves of the Sahang, a species of Pandanus. The second is named Apé Sala. This is also manufactured from the leaves of the sahang, which are first bleached, by sprinkling with water and exposing them in the sun, renewing the sprinkling until they become white. This mat is of a fine quality. The third is the Apé Niau; this is again finer than the preceding, and is manufactured from the bark of the *Hibiscus Tiliaceus*, or Vinghou of the natives. The fourth is the Amea, and is the most valued; it is a fine strong mat, but is not manufactured of as large size as the other varieties. It is made from the bark of a species of *Urtica*,† called by the natives Amea, from which the mat also takes its name. Apé is the general term for a mat or anything that serves for similar purposes. The war mats are of the same texture as the Apé Sala, but of a smaller size; four of these are worn

* A Rótuma chief, who accompanied us to the Island of Erromanga, brought from that island, on our returning thither, a stone which he seemed very solicitous of preserving: on questioning him for what purpose he designed it, he replied, that it was to place over the grave of his child, who had died the day previous to his departure from Rótuma, adding that Rótuma people like to place stones brought from another land over the graves of their family or friends. For what reason he could not tell, farther than that it was their custom.

† The flax from the bark of this tree is also used for making their fishing lines and nets.

together, fastened round the waist, when going to meet their enemies; they are placed each over the other, and so arranged as to display two deep vandykes decorated with red feathers on the edge of each, except the upper one, which has two oblong strips ornamented in a similar manner. It is usual to employ their women in the manufacture of the mats, a process so tedious as to occupy six months or more in the completion of one. They also manufactured cloth of various degrees of fineness, from the bark of the Ulu or bread-fruit tree, and the Chal or paper-mulberry tree. This cloth they call Wor; it is stained of various colours procured from native plants. The bark is beaten by a wooden instrument named Ia, of a similar form to that employed in others of the Polynesian Islands. The method of manufacture is also the same, and has been so often and correctly described, that an account of it is here unnecessary.

Considerable similarity, as regards features and general habits, exists between the natives of Rótuma and those of Tongatabu, yet they differ widely from each other in strength and bulk of stature, the former being much less muscular than the latter, and less capable of enduring hardship or fatigue. Presuming that these people came originally from some of the Friendly Island group, it would appear that the natives of Rótuma have degenerated from their aboriginal stock. This opinion of their descent is strengthened by the fact, that about a year previous to our visit, a canoe had arrived there from Tongatabu; it contained many natives from thence, none of whom, however, remained among them. It has been long customary for a large canoe, containing a hundred or more persons of both sexes, to leave the Island of Tongatabu for the purpose of visiting the Fidji Islands, and it is not improbable that being driven by tempestuous weather out of the sight of land, they may have reached some island before unknown to them. An innate love of roaming seems to exist among these people; they set sail without any fixed purpose in one of their large canoes: few ever return, some probably perish, others drift on islands either uninhabited, or if inhabited, they mingle with the natives, and tend to produce those varieties of the human race which are so observable in the Polynesian Archipelago. I frequently asked those of Rótuma what object they had in leaving their fertile island to risk the perils of the deep? the reply invariably was, "Rótuma man want to see new land;" they thus run before the wind until they fall in with some island, or perish in a storm. Cook and others relate numerous instances of this kind.

The following circumstance, which came under my observation, still farther illustrates this opinion. In April 1830, on landing at the Island of Tucopia, which is situated in latitude 12° 13' South, longitude 169° 0' East, I observed among the people two natives of Rótuma; their presence did not at first occasion me much surprise, conceiving it probable that they had been left there by whalers. On inquiry, however, I found they came down before the trade wind from that island, and were unable to return; they said there were others of their countrymen there also, where they had resided ten years, and had been kindly treated by the inhabitants; they, however, appeared anxious to return to their "home;" they were both middle-aged men. A short time previous to our arrival at the Island of Rótuma, a canoe with strangers had arrived, but from what island could not be ascer-

tained. I saw one of them, a fine-looking man, of the Asiatic cast of countenance; he seemed very sullen and adverse to answering questions, that is, if he understood them, which very probably he did not. It is on facts, and numerous facts alone, we can depend to elucidate this highly interesting subject; hypotheses may be infinitely multiplied, and each may appear equally plausible, but facts collected from authentic sources can alone set at rest a question which has excited such general attention in the minds of those interested in the study of the varieties of the human race.

Of religion, they seem, as far as I could ascertain, to possess very indistinct ideas; they believe that the spirits of deceased persons visit them after death, to appease whom they often make offerings, and hang up in their houses bunches of a shrub named Tenten, and wear it about their persons, for the purpose of keeping away evil spirits, for which it is considered to possess the virtue. They appear to have no idea of a future state. "The white people," they observe, "tell us that there is a heaven for good and a hell for bad men, but Rótuma man not know." On asking one of them whether this man, pointing to a dying Rótuma native, was afraid to die? "No," was the answer, "why should he?" "Then where does he expect to go after death?" "Why, Sir, if man die on shore, go in the ground; if man die on board ship, go into the sea," was the reply. A shout similar to the war-cry was raised when the body of one who had died on board was consigned to the deep; the chief to whose tribe he belonged, informed us this was intended as a compliment, "because he was a quick man, go up tree, catch plenty coco-nuts, catch plenty grub." The reason assigned by the natives of Rótuma why many of their countrymen die at Erromauga (one of the New Hebrides) was, "That they killed the Erromanga people, and that their spirits haunted them to death." They have houses where the offerings are made, but have no idols, and on the death or illness of a chief, a joint of the little finger is taken off as an offering; they also cut themselves with hatchets on the death of a chief. I observed at this island, as at Tongatabu, the women with circular scars over their bodies, which had been caused by the application of fire: some had them only on the chest, others covering nearly the whole of the body. This was effected by rolling up a piece of Wor, or native cloth, in a circular form, setting it on fire, and then striking it on the skin; this is practised on the death of a chief, or of parents. If the loss be a mother, the chest and breast are the parts burned; if a father, the back only. It was among the females alone that I observed this custom to prevail, who may frequently be seen almost entirely covered with recent burns on which the vesicles remained, without uttering any expression of pain; such is the force of custom. I met with a middle-aged female who was covered with recent burns, still in a blistered state; she informed me that it was for the death of the chief Konau: these burns were on the back, but the poor creature must have seen much trouble in her lifetime, as she had the marks of former ones still visible covering her back, arms, breasts, &c. and many of the recent ones over places where others had been before. It is said not only here, but at other of the Polynesian Islands, that burning or cutting themselves has the effect of assuaging or dissipating grief, as the pain produced by the burns or cuts causes them to forget their

mental to attend to their bodily suffering. On entering a house, the hospitable inhabitants always place some refreshment of coco-nuts, yams, &c. before strangers. I once was induced to enter one to ascertain the cause of accents of distress which I heard issuing, and I found a poor old woman sitting solitary on the ground crying most piteously, tears abundantly flowing down her cheeks: it was for the death of her son, her only child, who, anxious "to see new land," had visited the Island of Erromanga in a vessel, and was one among a number of others who had fallen victims there of fever. Even in the midst of her grief, the poor old creature did not forget the rites of hospitality; she placed bread-fruit, bananas, &c. before me, of which, however, I did not partake, but gave her some beads before I departed, as some consolation in the midst of her troubles. The natives of this island use the Kava or Ava as a beverage, similar to other islands in this sea, and cultivate it for the purpose, but I did not observe that it was used to any excess. The Kava bowls are neatly manufactured from the wood of the fifau tree.

The dances at this island are peculiarly interesting, and take place by torch-light; they resemble those I had previously seen at Tongatabu; by the men they were performed with much action in both slow and quick movements, with the usual accompaniments of clapping of hands, keeping accurate time with a monotonous but pleasing song from the party who composed the orchestra. The spectators applauded and encouraged the dancers by frequent shouts of "Mariai, Mariai!" (well done.) The females executed their part with considerable grace, in a slow and regular movement, which, added to the tasteful manner in which they had decorated themselves with flowers for the occasion, produced a pleasing effect. One dance by the whole "*corps de ballet*" was peculiar; the women formed the first row, and the men two other rows; much grace was displayed by the females in the sinking of the body, forming the graceful curtesy of the European ladies; the song which accompanied this dance was agreeable, though plaintive; the slow movement was concluded by one of very quick and rapid action by the male dancers, the women merely singing, clapping the hands, and making a slight movement of the feet in perfect time with the dance. All the dances we witnessed here were totally devoid of the disgusting and indecent actions exhibited in the dances at Tahiti, New Zealand, and others of the Polynesian Islands. We were entertained one day by the war-dance and a mock combat; as the latter was intended to demonstrate to us their mode of conducting warfare, I shall give a short sketch of the engagement. The party consisted of upwards of one hundred men, armed with hoibéluongs (clubs), spears, and baskets of stones; the highest chief present, who in this instance was the king's brother, headed the party. The preparation for action commenced by deafening shouts and shrieks, and furious stamping, which was done to intimidate their adversaries; this was followed by a propitiatory song to the spirits for victory. A few warriors advance from the main body and engage in single combat, with spears and clubs, with the warriors of the adverse party; if they conquer, the whole adverse body fly. The stone-throwers are then dispatched to annoy the retreating party by their missiles, which, by the accuracy of aim, acquired by constant practice, they do with great effect. The death of some of the warriors generally decides the victory. The entire of the successful

party pursue the beaten one, and usually kill great numbers with their clubs. In this mock combat several fell as if dead, and if a chief, he was stripped of his fillet of shells* and club, which were taken as trophies by the victors. At the conclusion of the combat, the whole of the dead bodies of the enemy are dragged and presented, together with the trophies, to the highest chief of the victorious party, and then counted to ascertain the number of slain. It was a formidable sight to witness so many clubs brandished in the air, accompanied by deafening war shouts and yells. They use the club with great skill, and it a formidable weapon when wielded by persons accustomed to its use. The clubs as well as the spears, the latter being from fifteen to twenty feet in length, are formed from the wood of the Toa-tree (*Casuarina equisetifolia*). Even in this petty island, the desire of the human race to destroy their own species is manifested; their fury being also excited to a great degree by their emulating songs.

As an evidence of the great desire of the natives of both sexes to leave their native land, I may mention the offers which were made to the commander of the ship, of baskets of potatoes and hogs, as an inducement to be carried to the island of Erromanga, where our vessel was next bound to. Two hundred were taken on board for the purpose of cutting Sandal wood, but from the unhealthy state in which we found the island on our arrival, and the numerous deaths that had occurred among native gangs that had been brought by other vessels for a similar purpose, we returned to Rótuma and landed them all safely. The perfect apathy with which they leave parents and connexions, departing with strangers to a place respecting which they are in total ignorance, is quite surprising, placing an unbounded confidence in those differing in colour, language, and customs from themselves: the young timid female, to whom a ship was a novelty, those who had never before seen a ship, were all anxious to visit foreign climes,—even, they said, London.

On the 25th of March the jolly-boat, in returning to the ship (Sophia) with a load of firewood, the wind blowing fresh at the time, was upset in the surf; the Midshipman in charge of her (Mr. F. Lamb) and one seaman perished: boats were sent as soon as the accident was seen from the ship, which succeeded in saving the remainder of the crew. This accident proved only the precursor of one yet more serious. From the 25th the wind blew very strong from west-north-west, and north-north-west, with a heavy sea running into the bay, and prevented our departure. On the 27th, the gales increasing in violence, the other anchors were let go, the top-gallant and top-masts were struck, and the main and fore-yards lowered on the deck. From the violent pitching of the ship we dreaded the cables parting, while the heavy foaming breakers astern rendered our situation most perilous. The wind from the 27th to the 29th occasionally moderated; but from constantly blowing into the bay, all attempts at getting under way were unavailing. On the 30th March a heavy swell rolled into the bay; the weather, however, was now fine and clear, the gale had moderated, and we were anxiously

* All the chiefs were distinguished by fillets of white shells (*ovula ovum*) around the head, in the centre of which was the famed and beautiful *Cyprea aurora*, or Orange cowry. The same kind are also worn by the chiefs both of the Fidji and Friendly Islands.

looking for a favourable moment to put to sea. About eleven A.M. the sky became again overcast, with every appearance of a heavy squall coming on from the old quarter, the north-west. It soon commenced blowing furiously, accompanied by heavy rain; this squall was followed by a strong gale, the violence of which, with the heavy sea rolling into the bay, soon caused our hempen cables to part, and we perceived that we were gradually dragging our chain-cable and anchor, and drifting towards the shore. As the ship approached the breakers, she rolled and pitched tremendously; all hands were assembled on the poop, across which life ropes were thrown, and all remained in anxious expectation of the first shock. A number of the crew were desirous that the anchor should be cut away, and the ship drive broadside on, as a greater chance of saving our lives; fortunately the commander and officers concurred in letting the ship drag her anchor, as it kept her head to wind. When we first perceived that we were driving on shore, guns were fired to induce canoes to be in readiness to afford us assistance; the sea however was too high to render it practicable: crowds of natives were seen assembled on the beach. A rock was now seen close to our stern; we had driven far into the bay, and the striking was momentarily expected, but by putting the helm up, and with the assistance of the driver, we passed it without injury and drove farther in. About one P.M. she struck, but not so violently as was expected: the rudder was soon lost; she pitched heavily, but again floated, striking at intervals; she ground down the soft coral rocks and went farther in, until she appeared to us to have been brought up by her anchor, which probably held some rock. The outer rocks which we had passed now afforded a breakwater, and the sea broke furiously over them, which otherwise would have deluged the ship. The reef inside the surf was of some extent, and was nearly dry at low water; but the tremendous surf that raged, and offset consequent on it, rendered all attempts to land unavailable. The gale still continuing with great violence, with no appearance of an abatement, about four P.M. Mr. Jones, the second officer, and four seamen volunteered to venture in a boat astern of the ship, (which still rode head to wind, being kept by her anchor in that position,) and endeavour to land and convey a hawser from the ship to the reef; the boat fortunately reached the reef in safety after a hazardous passage. A kedge-anchor, which was taken in the boat, was fastened to the reef, but the hawser attached to it in communication with the ship getting entangled among the coral rocks was rendered useless. From the success of the jolly-boat, a whale-boat was lowered, and sent in a similar manner to the reef; it made two passages in safety, taking some sick New Zealanders that were on board. The surf increased still higher with the rising tide, and the jolly-boat returning from the reef was swamped and soon dashed to pieces against the rocks; the two men in her were saved with difficulty by ropes from the ship. After this accident, and as the surf was tremendous, it was not thought advisable to venture any more of the boats this evening. As the tide rose, the ship floated as if in a basin; the gale rather increased than diminished with the approaching darkness, and no very agreeable night was anticipated. The ship rode comparatively easy from six to eleven P.M., but after that period, and about midnight, as the tide ebbed, she struck violently, swinging about and receiving such severe shocks as to shake the whole fabric. The carpenter was almost constantly sounding, and reported

the agreeable intelligence that she made no water. After a sleepless night, at dawn of day on the 31st the weather had moderated, so as to enable us to employ the boats in removing stores, baggage, &c. from the ship to the shore. The weather continued squally and unsettled during the day, and the gale again increasing towards night, the crew were all safely landed. Only one accident occurred, which, fortunately, did not prove of any serious consequence—one of the boats under charge of Mr. Hays, the third officer, was upset in the surf; the stores, &c. in her were lost, but the crew were saved by another of the boats. We formed a tent at a part of the bay named Haho, where we landed the baggage, &c. The natives were very friendly, assisting us in erecting the tent, bringing provisions, &c. The weather continued very tempestuous until the 2nd of April, when moderating, the ship was got off and again anchored in the bay, without having made any water of consequence. By the aid of native divers we procured the lower part of our rudder, it was united to the upper portion which remained attached to the ship, and being shipped, we were enabled to leave this unfortunate bay on the 8th of April. There were several whalers who had just arrived at the lee-side of the island, and some of the natives reported our situation to them in the following exaggerated manner—"That the ship had broke into ten thousand pieces;" this having been repeated to another native, he said it was not so bad as that, but "a large hole had been knocked in her stern, which the carpenter was endeavouring to stop to keep the water out." We succeeded in removing our stores, &c. from the shore to the ship, without any material loss from the natives.

Much wonder was excited, when I exhibited to the natives of this island coloured engravings of flowers, birds, butterflies, &c.; they imagined them to be the original plant or butterfly attached to the paper—no mean compliment to the artist. The engravings in Charles Bell's *Anatomy of Expression* always excited much interest when shown to the Polynesians; the plate representing Laughter never failed of exciting sympathy. A caricature representation of one of the fashionable belles of 1828 puzzled them exceedingly; some thought it "a bird," others that it was a nondescript of some kind, but when they were told that it was a Haina London, or English lady, they laughed, and said Parora, "you are in joke," so incredible did it seem to their unsophisticated minds.

One species of snake is found on the island, which is innocuous; it is named Alet by the natives, is of a brown colour, and about two feet commonly in length. A specimen which I brought to England, preserved in spirits, is deposited in the Museum of the Royal College of Surgeons in London.

The natives also manufacture from the leaves of the Pandanus, small pockets, named Hatfara, some of which are very neatly ornamented; in them they keep their trifles, &c.

In concluding the account of this beautiful island, we may observe with Malte Brun, that—"A new Cythera emerges from the bosom of the enchanted wave. An amphitheatre of verdure rises to our view; tufted groves mingle their foliage with the brilliant enamel of the meadows; an eternal spring, combining with an eternal autumn, displays the opening blossom along with the ripened fruits."

(To be continued.)

THE LATE VOYAGE OF H. M. S. CHANTICLEER.

THE present is a favourable season for the pursuit of scientific objects abroad, and accordingly several naval expeditions of this nature are now employed under the auspices of Government, in the various parts of the world. In Canada, Com. Bayfield is proceeding with his survey of the St. Lawrence; in the West Indies, Com. R. Owen, commanding the *Blossom*, is actively employed surveying; in the Mediterranean, Com. Copeland is engaged with his survey of the Archipelago; and on the Western Coasts of Africa, Com. Belcher is completing those parts left unfinished by the late Com. Boteler.* At home, we have several naval officers surveying the coasts of England and Ireland, which completes the list of our present scientific operations connected with the naval service. In comparison with what yet remains to be done, if we turn for instance to the Indian Ocean, the above list appears small. But we must not complain. A spirit has been evinced by men in power since the war, to take advantage of peaceable times. The numerous but unfortunate expeditions to Africa—the valuable surveys of Capt. W. H. Smyth in the Mediterranean—the extensive voyage of Capt. W. Owen in the *Leven*—the expeditions of Sir John Franklin in North America—those of Sir Edward Parry to the Polar regions—that of Capt. King lately returned from surveying the shores of South America—and, finally, that of the *Chanticleer*, under the late Capt. Foster, all tend to prove that such matters have been held in due estimation.

If we wanted a proof of the progress of science in the present day, we should assuredly point to the voyage of the *Chanticleer*. The two chief objects, namely, pendulum experiments to obtain the true figure of the earth, and observations for difference of longitude, may, perhaps, be considered the principal desiderata in the present day both for the navigator and astronomer.

It has been justly observed, that chronometers have become the pride of modern navigators, and that scarcely a “well-found” British ship goes to sea without them. So great a step attained in our merchant service, demands a corresponding encouragement on the part of Government, and setting aside the value of it in other points of view, what can be more beneficial than affording them the means of turning these valuable machines to a still better account, by giving them well-fixed meridians to start afresh from, as they would from Greenwich, at each turn of their voyage? A still better knowledge would be thus acquired of chronometers, the longitude would be more easily ascertained by them, and from the various points thus established, others intermediate might be determined with facility, from which geography would eventually derive incalculable benefits. In addition to these considerations, a series of magnetic experiments were included among other objects of this voyage, which combined to render it one of the most interesting and useful expeditions that have sailed from our shores since the days of Capt. Cook. Planned by men of the first experience, both in science and nautical knowledge, it was matured and submitted to the Admiralty only to be approved, and ordered to be performed. Com. Foster† was

* Since this was written, Capt. Fitzroy has been appointed to his former vessel the *Beagle*, to complete the charts of South America.

† Com. Henry Foster entered the navy in the year 1812, and successively served with the present Admirals Bertie and Alexander in the North Sea and Channel Fleets. In 1817, he joined Capt. Hickey in the *Blossom*, with whom he served till the year 1819, in the capacity of Midshipman. At the time that this ship visited the Columbia River with the Commissioners to establish the boundary line between Great Britain and the United States, he commenced his scientific operations by surveying the mouth of that river. When in the *Creole*, afterwards, with Commodore Bowles, he made a survey of the north shore of the river La Plata,

appointed to conduct the voyage in *H. M. S. Chanticleer*, which vessel was fitted out at Portsmouth under his superintendence, and supplied with all the instruments necessary to such a service. After having made experiments with the pendulum in high southern latitudes, as well as near the Equator, and carried the chronometric observations across the Atlantic and Ethiopic oceans in various parts, it was intended on his return that he should proceed with the same purpose to the Pacific and Indian oceans, and thus encompass the whole globe by a series of such observations. Being fully equipped and prepared for the first voyage, the *Chanticleer* sailed from Falmouth in May 1826.

The first place which the *Chanticleer* touched at was the island of Madeira, the longitude of which was measured to an extraordinary degree of accuracy. From Madeira, the island of Teneriffe in the Canary group, and Saint Antonio, one of the Cape Verd islands, were successively visited; the latter forming a point of departure for outward-bound ships, it was desirable should be correctly laid down. From thence the *Chanticleer* proceeded to the island of Fernando Noronha, where she arrived on the 20th of June, and afterwards at Rio Janeiro in the middle of July.

Few days were employed at Rio Janeiro in the necessary observations and refitting the vessel, after which the *Chanticleer* sailed for the island of St. Catherine on the coast of Brazil, where she arrived on the third day. To a spectator entering the bay of St. Catherine, between the island of Arvoredo, and Point Rapa, the north point of St. Catherine's, the view is of the most magnificent kind. The island, as well as the main land, is covered with a profusion of foliage of the most beautiful description, on which the eye rests with delight. The lofty summits of Mounts Bahul and Cambarella, are seen towering above the clouds, which cover the tops of the adjacent mountains on the coast, while beyond them in the distance, those of the interior gradually blend their hue with the thin transparent atmosphere. Cedars, orange-groves, laurels, and a variety of other trees, among which the tufted palm is seen bending gracefully in the wind, cover the face of the whole country. The cabins of the peasantry overlook the bay, and enliven the scene by their white-washed walls, forming a pleasing contrast with the dark green foliage by which they are surrounded. The bay, which is formed by the island with the main, is capacious and safe, the high lands that surround it affording ample protection from all winds.

The general anchorage is between the islands of Santa Cruz and the northern Raton Island, abreast of the town of San Miguel, which, from the houses being built apart from each other in a straggling manner, assumes a

which was of material service in constructing the present chart of that river. But it was not until serving in the *Conway*, under the command of Capt. Basil Hall, that his scientific qualities were fully evinced. In addition to the employment of surveying, he was here intrusted with the use of a collection of astronomical instruments, which had been supplied to Capt. Hall by the Board of Longitude. With these he made some excellent observations, which with pendulum experiments, the first he ever undertook, obtained him admission into the Royal Society. His next appointment was to the *Griper*, Capt. Clavering, on her voyage with Capt. Sabine to the coasts of Greenland and Norway; and on the return of this ship, in 1824, he received his Lieutenant's rank. In the unsuccessful voyage of Capt. Sir Edward Parry, in which he lost the *Fury* in Prince Regent's Inlet, Lieut. Foster had accompanied him as astronomer to the expedition. Here he employed the leisure afforded by an arctic winter in making some exceedingly interesting observations on magnetism, refraction, and the velocity of sound, besides those connected with determining latitude and longitude. For these observations, which are printed in the Philosophical Transactions, on the return of the last expedition of Capt. Parry from Spitzbergen, whither he had accompanied him, Lieut. Foster received the Copley Medal of the Royal Society, and in half an hour after his Commander's rank. His appointment to the present voyage took place a few days afterwards.

respectable appearance at a distance. The delusion, however, vanishes on approaching it, and it turns out to be formed of a few insignificant buildings. The principal object which attracts the attention on nearing the town, is a large water-mill, which is turned by a stream of water conveyed from a neighbouring hill by an aqueduct. Ships generally water here in consequence of its being good, and easily procured, although this article abounds in almost every part of the bay.

The island of Saint Catherine is about thirty miles long, and from four to eight in width. The original name among the Portuguese was *Isla dos Patos*, probably from the Indians who first inhabited it. In 1654, it was granted to *Dias Velho*, a Portuguese, by John the Fourth of Portugal, for the purpose of colonization. This person is said to have been assassinated by some English pirates, whilst carrying his plans into execution. Although families of Portuguese from the Azores settled on it at different times, it was not till the year 1740 that the government formed it into the province to which it now belongs. The surface of the island is formed of a soil the most favourable to vegetation, and besides being well watered, is varied by mountain and dale. Rio Ratonos is the principal river, and falls into the bay on the western side of the island. Rio Vermelho, Tavares, and Ribeirão, which two latter fall also into the bay from the south part of the island, are less considerable. The climate is no less favourable to vegetation than the soil. Rose-trees, jessamines, myrtles, and others, flourish in the greatest profusion. Nor is there any deficiency of trees for building. Canoes are constructed from single pieces of timber of fifty feet in length, and varying from four to five feet in width. Large quantities of rice are also grown, and the melons are considered the finest of the country. The climate is equally favourable to health. A refreshing sea-breeze tempers the heat of the sun, and renders the air cool and pleasant. The north-east trade-winds prevail from September to March, and the south-west during the winter months, of which August and September are remarkable for rain.

The principal employments of the men appear to be fishing and husbandry. During the winter season many are occupied in the whale fishery, and they have establishments to the northward of the bay at which they prepare the oil. The occupation of the women consists in working up cotton for their families. There is but little communication between these people and the native Indians who inhabit the interior. The Bay is frequented by ships of the country from Rio Janeiro, Bahia, and the river La Plata, which export rice, flour, oil, and several species of pottery manufactured by the inhabitants.

After about a week's stay at St. Catherine's, the Chanticleer sailed for Monte Video, where the pendulum experiments were commenced. Much delay, as well as inconvenience, was occasioned by the war then raging between the Brazilians and Buenos Ayreans, and in October following Com. Foster sailed for the southward to prosecute the more difficult part of the voyage. From Monte Video the Chanticleer proceeded to Staten Island on the coast of Tierra del Fuego, where the pendulum was again employed. The time thus occupied was also devoted to a survey of the island. The plan made of it by Lieut. Kendall, who was then in the Chanticleer, is the only authentic one extant, and sufficiently illustrates its extraordinary nature.

The meridian distance between this island and Cape Horn was ascertained, after which the Chanticleer steered to the southward for New South Shetland. Ice islands were quickly met with after leaving Cape Horn, and at one time they were so numerous, that with a heavy sea and gales of wind, the Chanticleer was frequently in a perilous situation, from which it demanded all the skill and vigilance of her captain and officers to extricate her. The fogs and constant rain which were met with here, as well as the change to a cold climate from the heat of the Torrid Zone, contributed to render this the most unpleasant part of the voyage. It had been wisely planned that the Chanticleer should be delayed as little as possible near the Equator.

Among ice islands in a boisterous sea, attended with fogs, rain, and gales of wind, the little Chanticleer had no easy task to get to South Shetland. On the 10th of January 1829, the Island of Deception, one of the New South Shetland group, was discovered, and a safe anchorage in the *interior* of it was shortly found. This island is justly entitled to its appellation, and is one of the most extraordinary productions of Nature. Its formation is entirely volcanic, the principal part being composed of lava, ashes, and ice. The shores rise to an elevation of some hundred feet, particularly on the north side, which is considerably higher than the south, and being circular, of about seven miles in diameter, it appears from a distance to be one large mass from shore to shore. In searching for a harbour to receive the Chanticleer, an opening was discovered about two hundred feet wide on its south-east side, and on farther examination, it was soon found that a large circular basin of about five miles diameter, occupied nearly the whole *interior* of the island, the external shores forming a perfect barrier or wall, thereby affording the utmost security within. The depth in the centre of this basin was ninety-seven fathoms, rather too much for anchorage, but a small cove on its eastern side gave ample security to the Chanticleer.

The pendulum was employed here and the necessary observations performed, whilst the officers of the Chanticleer surveyed and explored this extraordinary island. Several small coves were found on the borders of the basin, and some stones placed on each other in a rude, clumsy manner, near one of them, were discovered to have been used by the crew of sealers for the purpose of boiling their oil. Nor were these the only traces of the sealing vessels, for in the exploring expeditions which were constantly going forward, another pile of stones on a neighbouring eminence was found, on examination, to contain the corpse of a man. He had evidently been a sailor belonging to one of these vessels, but of what country could not be discovered. There was nothing found near him to indicate how he had died, nor at what date. He was found lying on his side in a roughly-formed box, clothed in a red woollen shirt. The stones were carefully replaced, and a notice left on the spot that his remains might not again be disturbed.

The external, as well as the internal shores of this island, from the friable nature of its materials, present some very remarkable appearances. The eastern side is entirely faced with cliffs of ice, about three hundred feet in height, which the constant washing of the sea forms into singularly fantastic shapes. Similar cliffs are also found on the south and south-west sides, and their base is bounded by a beach of ashes and lava, which extend round the whole island at low water. The examination of the basin was attended with considerable difficulty, arising from the small ashes and dust which were carried into it by the wind from the island. Seals, and their companions, penguins and sea-leopards, were the only inhabitants found in this desolate island, which affords not the slightest verdure. Streams of water, at a temperature of 140° and 160° of Farenheit, were found issuing in some places from the sides of the hills, and running into the basin, the water of which was scarcely above the freezing point. It is generally supposed that this basin was formerly the crater of a volcano, and that the sea has found its way into it by washing out the narrow passage by which the Chanticleer entered. How long it has been resorted to by sealing vessels is unknown, but it is not unlikely, that known only to one or two, its situation may have been kept secret, in order to secure it from being visited by the numerous vessels in that employment.

The Chanticleer left the Island of Deception on the 8th of March 1829, and proceeded to Cape Horn, where the necessary observations detained her until the 25th of May. The passage which she experienced convinced Com. Foster that he had been quite long enough in these southern latitudes, and it was with no little satisfaction that he quitted this coast for the Cape of Good

Hope. A severe gale of wind drove the Chanticleer three hundred miles to the eastward of the latter place, and after finding shelter with some difficulty in Mossel Bay, she arrived at the Cape on the 16th of July. The time occupied here by the observations which were required, afforded ample opportunity to the officers and crew for the enjoyment of that relief from their fatigue which they so much needed. Her stay was accordingly prolonged by a variety of scientific objects, until the 13th of December, on which day she sailed for St. Helena, and arrived on the 26th of the same month. At this place the Hecla was found with her few surviving officers from the coast of Africa, to which ship Lieut. Kendall, one of the officers of the Chanticleer, was appointed.

The observations in Lemon Valley detained the Chanticleer till February, when she sailed for Ascension, and arrived there on the 14th. Much has been done in this small island by Government to secure the advantages that our naval force may obtain from it in any future war, and much credit is due to the Commandant, Capt. Bate of the Marines, for his judicious arrangements. Situated in the midst of the ocean, nearly half-way between the African and American continents, from which latter it is distant about twelve or thirteen hundred miles, it will afford a rendezvous, from which an expedition may proceed to any adjacent part of the world. But considering it in the light which is principally intended, that of furnishing our ships with supplies of vegetables and provisions, every establishment for such a purpose must be wished for, and this, from its geographical position, is rendered particularly desirable. The climate of the island is most healthy, and it has long been the resort of our African squadron for recovering from the pernicious effects of the coast.

Ascension is about twenty miles in circumference, being about five miles across from north to south, and seven from east to west. According to the observations of Capt. Sabine, who visited it lately, Fort Cockburn, at George Town, is in Latitude $7^{\circ} 56'$ S. and Longitude $14^{\circ} 24'$ W. Composed of volcanic remains, the principal requisites for vegetation, soil and water, are its greatest deficiencies, and these it is the part of British enterprise to supply. The former has been conducted there from England, and the latter by the judicious construction of tanks and arrangement of water-pipes, is obtained in abundance from the only high land in the island. The settlement, which is named George Town, is situated on the western or *lee* side of the island, composed of the Government buildings, so arranged as to form nearly a square, and is garrisoned by a strong party of Marines, at present under the command of Capt. Bate. The whole island is also under his authority, and has been improved very much by his judicious management. Cross Hill overlooks the town, being close to it, and about 900 feet high; but the principal high land is the Green Mountain, in the N.E. part of the island, which rises to a height of 2870 feet. Surrounded by plains of cinder-ashes, pumice-stones, and lava, the component parts of the whole island, this mountain presents the only signs of verdure, the cultivated land being about eighty acres. The crops it has yielded have been abundant, and the vines and fruit-trees which have been transplanted from Madeira, promise well. The arrangements by which a constant supply of water is now preserved, are of an extensive nature, and consist of four tanks, communicating with each other by a series of iron-pipes of about 2500 feet in length. The upper tank is called the mountain-tank, and will hold a hundred and thirty tons of water. Another at Dampier's Springs in the mountain, below the former, whose dimensions are eighty feet long by twenty wide, is calculated to hold 500 tons. The principal one, which is near the landing-place, and is 100 feet long by 50 in width, will contain 1200 tons, having been only of late completed. With these it is expected that a constant supply of water will always be preserved. Great improvements have also been made in the landing-place and the fortifications of the

island, and the whole appearance of George Town displays a neatness in order and arrangement which is sought for in vain among the villages of the Torrid Zone.

From Ascension the Chanticleer sailed in June 1830 for Fernando Noronha, to obtain the meridian distance between them, and thus confirm the former observations. In the passage to this island from the Cape Verds, the opportunity was taken of fixing the position of the Penado de San Pedro, or St. Paul's Rocks; and it is curious that they should have been very wrongly laid down in latitude on our charts, while the longitude happens to be within a mile of that determined by Com. Foster. The usual attendance in these latitudes of variable winds, calms, thunder and lightning, with heavy rains, were met with here in profusion, and a strong current was found in the vicinity of the rocks, which set the Chanticleer eighteen miles to the westward in the course of twenty-four hours. The Latitude of them determined by Com. Foster, is $0^{\circ} 58' N.$ and Longitude $29^{\circ} 16' 40'' W.$ differing three miles of latitude from its supposed position, and two minutes of longitude.

To follow the Chanticleer with the same detail to the remaining places that were visited by her, would lead us far beyond our limits, and we are content in leaving them in the hands of Mr. Webster, the Surgeon of the vessel, who, we understand, is preparing an account of the voyage for publication. The pendulum experiments had been successfully made at the various parts required in the South Atlantic Ocean, and the meridian distances ascertained. The next point of importance was to connect these latter observations with Panama, which place being on the shore of the Pacific Ocean, was of the utmost consequence, from its affording the means of connecting them by short runs between the islands of the Pacific and Indian Oceans with the Cape of Good Hope, and thus to complete the circuit of the Globe with a series of meridian distances. So magnificent a project, and one so worthy of that high character in maritime affairs which belongs to Great Britain, whose ships have penetrated every navigable part of the Globe, was not reserved for Com. Foster to execute.

From Fernando Noronha the Chanticleer successively visited Maranham, Para, Trinidad, and La Guayra, and shortly after arrived at Porto Bello. The events which occurred afterwards are so expressively related by Lieut. Austin,* the First-Lieutenant of the Chanticleer, in a letter to Capt. Beaufort, the Hydrographer to the Admiralty, that we gladly avail ourselves of permission to place so authentic a document on our records, and particularly so as the false report relating to his death which got abroad has not been yet eradicated.

“ H. M. Sloop Chanticleer, off Chagres, 9th Feb. 1831.

“ Sir,—The length of time that Capt. Foster and I have been personally acquainted, and more especially having been selected by him as his Senior-Lieutenant on this unfortunate voyage, will sufficiently account to you for the knowledge I possess of his sentiments. Such being the case, I consider it my duty on the present occasion to give you the earliest intimation of our ever-to-be-lamented loss.

“ On our arrival at Porto Bello on the 22nd of December, Capt. Foster immediately began the pendulum experiments, and dispatched me to Panama, to ascertain the practicability of measuring across the isthmus by rockets, in pursuance of his orders. The journey across being performed wholly on foot, I did not return to the ship until the 12th January, when I found Capt. Foster had finished his experiments, and was anxiously awaiting my arrival. Indeed, he was so solicitous to prosecute with all possible dispatch and fidelity the admeasurement of the isthmus, that he had determined on sailing for Navy Bay on the 13th, had I not arrived. In my report I represented to him the extreme difficulty and impracticability of measuring by chronometers, *via* Porto Bello. We accordingly sailed for Navy Bay on the 13th, and Capt. Foster left the ship in his gig for Chagres at daybreak

* Since promoted to the rank of Commander.

on the 4th inst. taking with him two chronometers and the requisite instruments. He intended to have proceeded up the river in his gig, but on his arrival at Chagres, he preferred taking one of the country canoes as far as Cruces, and thence to travel overland to Panama.

"To co-operate with him, and to ascertain positively whether the experiments could be performed agreeably to his instructions, the Second-Lieutenant,* with a strong party, was sent to Porto Bello in the launch, with orders to proceed to an elevated and central station, recommended by me as the most eligible for the purpose. The rockets were fired from this place at the appointed times, but were not seen either by Capt. Foster at Panama, or by the officer stationed on the hill contiguous to Porto Bello. Capt. Foster returned to the ship in Navy Bay on the 25th, in good health and spirits, as well as the whole of the rocket party from Porto Bello. The Captain remained but two days to get the error of his watch, and started again on the 28th, accompanied by the Second-Lieutenant, and a small party for firing rockets at Cruces, his object then being to measure the meridian distance between Panama and Chagres. Every thing had been done at Panama; the experiments were concluded, and the Captain embarked in a canoe at Cruces, on Saturday morning the 5th of February, to return down the river, exulting in the success of his observations. In the dusk of the evening, the canoe having passed down a rapid, some extraordinary sensation was excited in his mind, and he rose to see that all was right. He got out at the after part of the canoe, and was seating himself on the top of the thatched awning or covering, with his foot on the gunwale, when the awning gave way, and he was precipitated into the river. The awning was nothing more than a frail texture of dried reeds. At the same moment, an enterprising young officer, Mr. Fox, and the Captain's trusty coxswain, Peter Veitch, jumped overboard, and exerted themselves in the most noble manner, but in vain! Our unfortunate but highly talented chief was seen to their horror sinking in the water, and in a very few moments he disappeared, and was lost to us for ever! Those who jumped overboard so promptly were quickly obliged to regain the canoe; but they remained two hours on the spot searching unsuccessfully for the body. They proceeded to Chagres that night in great distress, and early on Sunday morning brought the melancholy account to the ship, which was under way off Chagres, waiting the arrival of Capt. Foster. Such was our dismay at the disastrous intelligence, that I have not words to express our feelings—for though but a humble admirer of science, my zeal and patriotism have often called forth prayers that our talented chief might be preserved to the completion of his mission.

I immediately dispatched the gig under the direction of the master, with five days' provisions, to search diligently for the body; and at the same time offered a reward of twenty dollars to any of the natives who should procure his remains, in order that they might be interred. And it is some gratification to be enabled to add that we were fortunate enough to obtain the body on the following Tuesday. Lieut. Williams, who had been left at Cruces to superintend the rockets, on becoming acquainted with the distressing accident, immediately came down in a canoe, and joined the party I had sent up in the gig. They found the body floating a few miles below the place where the accident had occurred. The dreadful state in which it was, made it impossible to bring it down the river; it was, therefore, deemed advisable to inter it on the spot. A grave four feet in depth was dug, and shrouded in the colours of our country, it was buried with every attention that circumstances would permit. The grave was banked, well staked, and decently wattled. A board was carved by Lieut. Williams with his name, the date, and manner of his death, and conspicuously affixed to a lofty tree immediately over the grave, so that it may be easily seen by any one passing the place."

Alas! poor Foster, to watch over thy silent, lonely grave! And soon will the mouldering hand of time, invidious of thy well-earned name, grudge thee even these poor relics—

"For deeds do die, however nobly done,
And thoughts of men do in themselves decay."

* Lieut. Williams.

But what wilt thou reckon, does the stranger pass the spot heedless of thy name?

To return to Lieut. Austin, he adds—

“ To Lieut. Williams’ exertions and kindness on the occasion, I cannot bear sufficient testimony, and it is a great loss to this gentleman, that I have not the pen of Capt. Foster to detail to you his able services and scientific attainments, for he was always associated with Capt. Foster in his labours and observations. With his assistance, I look forward to be enabled to give you satisfaction in the hydrographical department.

“ It is necessary to inform you, that Capt. Foster’s body had been plundered by some of the canoe-men of his valued private chronometer, together with his notebook, containing all his observations since leaving Porto Bello; but the Government watch was found in a breast pocket on the left side, and escaped detection—I presume from the unusual circumstance of a person carrying two watches.

“ Having obtained permission from the Governor to erect a tablet to his memory in any place I might think fit, I have accordingly done so in the fort of St. Lorenzo at Chagres. It is a large piece of very hard and durable wood, cut in the usual form of a grave-stone, bearing a copper plate, with the following inscription neatly engraved thereon.

“ This tablet is erected by the senior Lieutenant and officers of his Britannic Majesty’s sloop Chanticleer, to perpetuate the memory of their late Commander, Henry Foster, F.R.S. who was drowned in the river Chagres on the 5th February 1831, while measuring the difference of longitude between Panama and Chagres. This talented and distinguished officer was employed in nautical and astronomical science, having nearly completed his mission of three years’ duration. He fell at his post, ripe in honours, but young in years. *Ætat 36.*”

“ Afterwards was placed beneath the former,

“ His remains were found on Tuesday, the 8th, floating in the river a little below Palomatia, and buried on the spot.”

Lieut. Austin continues,—

* * * * *

“ I have forwarded by the same conveyance as this, an official statement of the event for the information of my Lords Commissioners of the Admiralty.

“ Thus I believe and hope that everything has been done with propriety, and that I have entered into all the detail that a letter admits of. Permit me to apologise for the length of the communication and the trouble I have given.

“ With every sentiment of respect,

“ I have the honour to be, Sir,

“ Your obedient humble servant,

(Signed) H. F. AUSTIN.”

Such intelligence was as unexpected at home as it was on board the Chanticleer, while she was under way off Chagres, and equally distressed his friends here, as it had his officers. But the event was past, his country had lost a most valuable and scientific officer, and his relatives, with their fondest, but early-blighted hopes, were left to mourn the loss.

The command of the Chanticleer, of course, devolved on Lieut. Austin, who, after having taken the steps mentioned in his letter, lost no time in executing to the best of his power the remaining part of Capt. Foster’s orders. As this consisted only of measuring the meridian distance between a few more points, namely, the east end of Jamaica, Cuha, St. Thomas’s, Bermuda, and the Azores, these were obtained on the way home, by which all the objects of the voyage were fully completed, excepting the longitude between Chagres and Panama, the notes of which were lost with Com. Foster. The Chanticleer returned to Falmouth, and on being paid off at Woolwich shortly after, Lieut. Austin and Mr. Williams received that promotion which they so justly merited.

EFFECTS OF INTEMPERANCE IN THE FLEET AND ARMY—
AND ITS REMEDY.

IN a work which has the welfare and happiness of the United Services for its express design, the honour of the British arms for its peculiar care, and the glory of the British empire as the object of its most anxious solicitude,—in such a work no apology seems necessary in calling the attention of its readers to the consideration of a subject of so vital importance to our happiness, honour, and glory, as that which forms the subject of the treatise* now before us on the extent and remedy of national intemperance. The author commences with an animated description of the nature and extent of inebriation in Scotland:—

“Those ruthless conquerors who, in their wasting career, have created numberless widows and orphans amid the havoc of kingdoms, and for a time overspread regions with amazement and despair; those mortal pestilences which in some brief but desolating month have subdued smiling districts to the aspect of the shadow of death, have severally been denominated scourges of the human race. But it may be confidently declared that no mischief in the sorrowful annals of inebriation—the dominion of intoxicating liquors; and none has achieved so effectually its deleterious empire over both the bodies and the souls of men.”

In tracing the history of this gigantic evil, our author goes back to remote antiquity, and concludes with the following powerful observations:—

“In more modern times, the tyrants of Scotland, during the religious persecutions, the Lauderdale and Middletons of the seventeenth century, amid heartless and mad carousals, took cruel counsel against the virtuous of the land, and issued those destructive orders, that on the hill side, in the innocence of their rural farms, and amid the tears and distraction of mothers and children, flamed over our fathers in the bitterness of death. And although in present times it has not been our lot to witness this sin outrageously exerting itself by violent and hasty revolution in the plunge of kingdoms, yet have we within half a century beheld its creeping sloth-like progress in our population, whom it has now lowered to such a state of degradation, as that we seem to stand in imminent danger of sinking to a depth of moral turpitude far below the tide-mark of continental nations, notwithstanding all the stability of our transcendent civil and religious privileges.”

From the parents, the vice seems at length to have descended to the children. Our author informs us—

“That we have the hopeless grief of hearing our very boys in the streets bragging of their feats and familiarity with the liquid poison.”

And again—

“From one official report on the subject, I am induced to believe that the balance of intoxication, as compared between the sexes, now preponderates on the female side.”

There is (says Mr. Hume) in human affairs an extreme point of

* On the Extent and Remedy of National Intemperance. Published by William Collins, Glasgow.

depression from which they naturally begin to ascend in an opposite direction. Some eighteen months ago Scotland appears to have arrived at this point, when the philanthropic author of the work before us at last succeeded in arousing his countrymen to a sense of their dangerous situation; from that happy period Temperance Associations, in despite of inveterate habit, prejudice, and self-interest, have been making a most rapid progress in the north, and those combinations of the wise and virtuous of the land promise at no distant period to blot out the darkest spot from the moral history of their country, and place her in that high station which she once occupied amid the nations of the earth.

In looking to the Temperance Record for May, we observe that there are now 203 Societies in Scotland, consisting of 40,529 members, and that for some time past the monthly increase has been about 4000 individuals. In discussing the remedy of this vast national evil, our author proves the advantages, which example, accompanied with combined exertion, has in this as in most other matters over precept, and appeals to the great public experiment which has already been made in the United States of America, from which the most salutary lessons may be obtained. It appears that the sin of intoxication was there, from whatever means, a more prevailing mischief among the upper classes at least than in our own country,—our consumption amounting to about thirty millions of gallons of spirits per annum, while theirs exceeded fifty millions of gallons in a much smaller population.

“The subject of intemperance (says our author) had been long mourned over by the wise and patriotic in that land; *much unconnected exertion* had been used, and many plans adopted to stop the growing evil and reduce the population within the bounds of moderate indulgence.

“But every exertion had hitherto failed, and the influence of intoxication predominated more than ever. An important discovery, however, has been made, which lies in the transcendent benefit to be reaped in the agitation of this matter from *combined exertion*. But above all, the happy results that have lately followed are, by our trans-atlantic friends, chiefly referred to the resolute and uncompromising principle of utter abstinence by a portion of the population; which is justly looked upon as the *sine quâ non* and basis of all successful effort on this question. The principle of the American Societies may, therefore, be shortly stated as utter, immediate, sudden, and complete abandonment, combined with associations to a certain extent in all ranks of society. This will undoubtedly appear to every man who begins the consideration of this most interesting subject as a startling difficulty; and the notion of obtaining, in this manner, a cure to the inveterate abuse of wine and spirits in this country will, without fail, be viewed at first sight more as the phantasm of a fanatical enthusiast than the sober conclusions of a rational citizen. We must not, however, permit our preconceived opinions to outweigh the testimony of authentic fact, for it is demonstrated from the records of the American Societies, that this principle adopted by a few, and aided in its progress by an associated chain of institutions, has nearly slain the gigantic evil that threatened to bury the whole nation in literal family and individual destruction.

In the present state of society in Scotland, therefore, it appeared necessary that a certain portion of the upper ranks should for a time relinquish the use of wine, at all events of ardent spirits; that they should form a voluntary association throughout the land, the basis of which should be abstinence, and on no account to introduce any element of force into the plan, which is contrary to the essential princi-

ples of solicitation and free-will. The results of this patriotic self-denial is becoming more and more observable, as we have shown from the Temperance Record of Scotland to which we have already called the attention of our readers. It may be asked why should moderate drinkers in the upper ranks practise abstinence? Why should they make a sacrifice, and what effect will self-denial on their part have on the drunkard of low degree? To this we answer, that the lower ranks derive all their views and feelings from the higher. Fashions are never known to press upwards; example, therefore, is the only means by which the upper ranks can with any prospect of success enforce temperance on the common people: fashion is every thing with us; what in fact has of late years produced the comparative sobriety among the better orders in Britain, but the fashion of imitating Continental temperance?

There is another, and we think a most important result, proceeding from the combined effort of the latter classes in reclaiming the slave of dissipation and in the repression of drunkenness. Let us consider that crime of all sorts is progressive, that the drunkard was once a sober man, that he then became what is called a moderate man, he afterwards began to exceed step by step; he sinks to the lowest extremes of brutal intemperance as he advances in this pernicious course, at every step he loses a portion of the good opinion which his respectable friends or neighbours had formerly entertained for him, and of course a portion of that manly self-respect which is due to himself, and without which no one can act a wise, a virtuous, or an honourable part in society: but after he has arrived at the lowest stage of intemperance, after, like the leper of old, he has been expelled from the camp, lost to his friends, his country and himself, even here, however he may endeavour to conceal the fact from himself and others, in his heart he cherishes a respect for the sober part of the community, from whom his own indiscretion and folly have shut him out, and the warmest aspiration of this poor wretch is once more to be admitted into that society. Here then is the advantage of the moderate portion of the community practising abstinence; they know that this poor man cannot come to them, they accordingly meet him half-way; they tell him that his salvation depends on his abstaining from spiritous liquors, yet they ask him not to submit to any privation to which they themselves do not submit; they ask him to relinquish that which is undermining his health, ruining his affairs, and bringing his family to present and eternal misery; they ask him, in short, to join in their association; and what is the consequence? the man is at once raised a step in society, he at once gains a portion of the respect that he owes to himself, and if he only has the firmness to persevere, (which we are happy to say is done in almost every case,) this association with sober men will lead him back to the paths of duty, and bring domestic peace and joy to his home, which is now the abode of squalid poverty and wretchedness.

Such, then, is the remedy that has been proposed for intemperance, and which has been found to produce the most beneficial effects in civil life. We are most happy to observe that the system has also been transferred, and is now acted upon by a portion of the military. In the last Temperance Record, we observe that the 4th Royal Irish Dragoons, and the 91st (Argyleshire) regiments have each adopted the plan of

Temperance Societies. How would this work in the Navy? We are all but too well acquainted with the baneful nature of intemperance in that service; we know from painful experience, that if all the crimes committed in the navy were divided into five equal parts, four out of the five, at the very least, would be found to proceed from drunkenness; all quarrels, all riots and tumults, all neglect of duty, insolence to superiors, mutinous or seditious language, and other enormities, have ever been the issues and product of excessive drinking; and how often does the drunken revel end in the cry of murder! how often does the hand of the inebriate, in one rash hour, perform a deed that haunts him to the grave! One third of the patients confined under insanity, have brought that terrible disease upon themselves by drunkenness—"Oh! that a man should put an enemy in his mouth to steal away his brain."

Almost every accident that happens on board of ship may be traced to the same prolific source of evil; when our men fall from aloft or are lost overboard, have their limbs fractured, or are upset in boats, in short, in almost every instance where they either give or receive injury, the remote or proximate cause of the harm is to be found in the intoxication of one or of all the parties concerned; and in the upper ranks, how many honourable and gallant young men have we seen lost to themselves and their country solely from dissipation! wretched in fortune and in fame, blighted in health, in hope, in happiness, in expectation, pursued by misery and wretchedness in this life, or brought unwept and unhonoured to an early grave.—"Oh! thou invisible spirit of wine, if thou hast no name to be known by, let us call thee, the ——— devil."

We have served during the war, and since the peace, in sixteen different ships of war, and we have taken passages at various times in about as many more; from our youth upwards, we have heard the subject of intemperance mourned over, we have seen many plans adopted, and much severe punishment inflicted for the purpose of putting a stop to the influence of intoxication, yet in all our experience we have never known the drunkard reclaimed by means of corporal punishment; we contend, therefore, that it is not to be flogged out of him; he may be scared for a time from terror of the infliction, but without some moral check the demon will most assuredly return doubly armed, aided rather than repressed by the moral degradation which repeated punishment must ever produce.

Wine and beer may be necessary as anti-scorbutic to sea-faring people; with ardent spirits it is quite otherwise; there is more virtue as an anti-scorbutic in one ounce of sugar with lime-juice than in a pint of spirits: would not the utter abandonment of ardent spirits be of the utmost consequence to the service? It might be done at once were the officers one and all to take advantage of the discovery which works so beneficially on shore, and which consists in the transcendent benefit of example and association; there are no class of beings on earth who follow the example of their officers for good or for evil with such sympathising good-will as sailors, and the readiness with which they relinquished a portion of the ardent spirits which formed a part of their allowance a few years ago, redounds to their immortal honour, and is another convincing proof of the fact that was formerly stated in this Journal—"That the progress of civilization may be traced in the advance of our military institutions more perfectly than in the laws

affecting civil life and property and morals." So far as regards the officers of the British navy, we humbly implore them to observe and satisfy themselves with the beneficial results of Temperance Societies on shore; that is all we require, well assured that we address ourselves to men ever anxious to exert themselves for the good of the service, and who, when once convinced of the absolute utility of a measure, will never suffer self-indulgence to interfere with public duty.

N. C.

** The following note appended to a notice of a Public Meeting held at Exeter Hall, London, on the 29th of June last, on this subject, will, in some degree, exemplify the extent to which this evil has extended generally.—Ed.

"The present habits and customs of Society are rearing up a generation of drunkards. The selling of spirits to children has of late become an important branch of trade. Four millions of gallons of ardent spirits were consumed in the United Kingdom in 1829, more than in 1828. Above twenty millions of pounds sterling was paid by the working classes alone last year for ardent spirits. Beggary and disease, crime, madness, and death, are the dreadful results of this awful intemperance. Temperance Societies have created a new era in America. They are working an amazing change in Scotland and Ireland, and it is only necessary for Englishmen to associate, and to declare their resolution to *abstain from Distilled Spirits and to discountenance the causes and practices of Intemperance*, in order to save their country from becoming a land of drunkards."

AN IMPROVED LOG-SHIP.

BY LIEUT. THOMAS GRAVES, R.N.

AMIDST the various propositions and alterations that have lately been made in the equipment of a ship, among which may be mentioned the improvements in both binnacle and azimuth compasses by Capt. Phillips, and the iron plates for counteracting the effects of local attraction by Professor Barlow, it appears rather extraordinary that the useful machine called the *Log-Ship*, so intimately connected with both of these, should seemingly have been quite neglected: whether it may have proceeded from its apparent unimportance, its simplicity, or its supposed efficiency, it is not pretended to decide, at all events it remains untouched and unthought of, and it is the object of the present communication to offer what appears an improvement.

To those who are not nautical men, a slight description of that at present in use may not be unacceptable, or uninteresting.

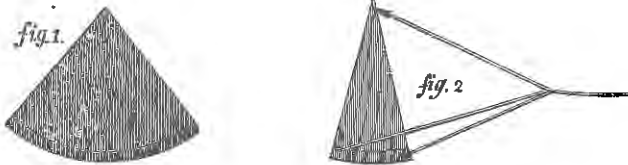

The common *Log-Ship* (Fig. 1.) is a flat piece of wood in the shape of a quadrant, loaded with a sufficient quantity of lead on its circular edge, to make it remain in a perpendicular position on, or near the surface of the water: to this is attached the log-line, (Fig. 2.) divided into spaces called knots, the distances between which bear the same proportion to a nautical mile, that twenty-eight seconds do to an hour, and

wound round a reel. This being held by one man, and the twenty-eight second glass by another, the *Log-Ship* is thrown over the ship's quarter to leeward, and swimming perpendicularly remains nearly stationary: when the first mark goes out, which is generally about eighteen or twenty fathoms from the *Log-Ship*, the glass is turned, and at the time the sand in the glass is run out, the line being stopped, shows, by the marks on it, the rate at which the ship is sailing per hour.

The *Log-Ship* now proposed, is a cone composed either of tin, or thin copper, (see figure) with the part *a, a, a*, made air-tight, which

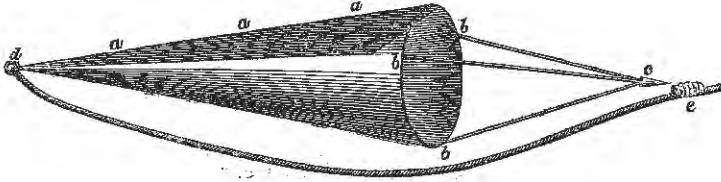

in light winds will prevent its sinking, and also preserve its horizontal position, when thrown overboard near the surface: it is slung at the points *b, b, b*, by lines much smaller than the standing part, uniting at (*c*), where a spicket or peg is attached; at the end of the cone (*d*) the line itself is secured, and on it at (*e*) is fixed a faucet that receives the peg; the *Log-Ship* is then ready for use.

The advantages it will have over the old construction are, that when the log-line is stopped, the increased weight of water in the cone causing the peg to come out easily, it instantly turns over, and may be hauled in without any resistance; that it will remain more stationary when thrown overboard; that a following sea, from its shape, will not have so much effect in propelling it after the vessel; that it will not carry away so many log-lines, (as in the event of the peg not coming out, one of the small lines to which it is attached must give way); that it will always catch properly, which the one at present in use scarcely ever does; and at the same time the expense will be no consideration; and on board any of His Majesty's vessels it may be made in as short a time as the old one, by which is obtained the ships' rate of sailing at all times with greater accuracy; and it will prove of essential service in making the land during foggy weather, while the other, from its numerous imperfections, can never be depended upon.

As its construction has been approved of by many naval officers, several of whom have had opportunities of using it; and from repeated trials of my own, it answered all the objects proposed, I feel less diffidence in presenting it to the public.

The valuable invention of Mr. Massey, at Liverpool, is on an entirely different principle; it cannot be too highly recommended, but its expense is a great obstacle to its general introduction; whereas the proposed one is recommended by its simplicity and cheapness.

The log-line, although liable to some error from contraction and expansion, in being alternately wet and dry, becomes tolerably well seasoned with salt water after a little use, so as to render it quite sufficient for the purpose intended; still there is much room for improvement, and perhaps one made from cotton would be less affected by the causes above-mentioned.

CHAIN MESSAGERS.

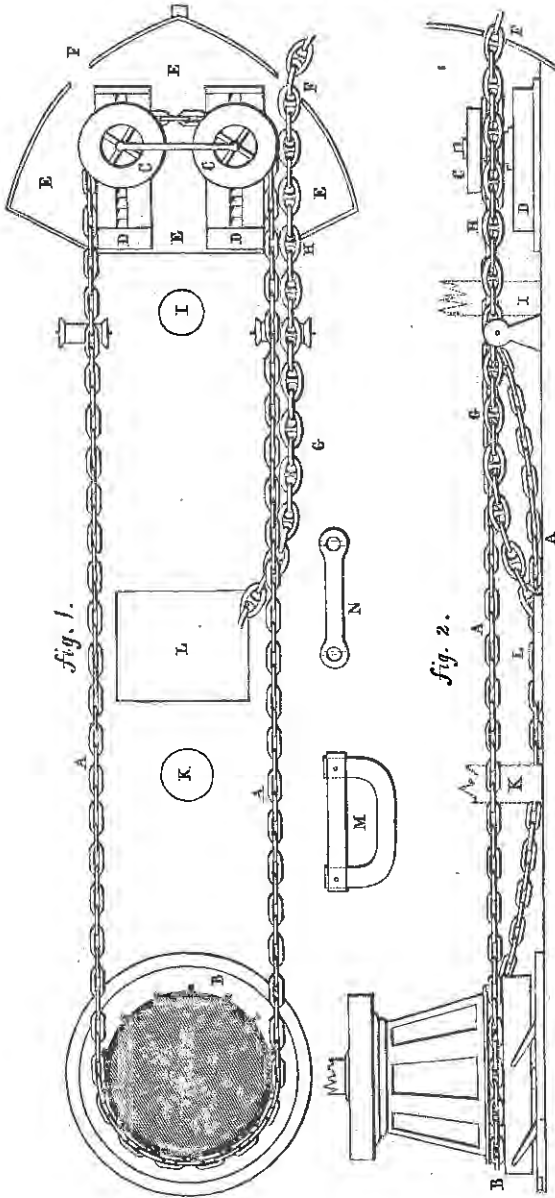

ON our preceding page is a drawing of a Chain Messenger, invented by Messrs. Gordon and Co. London, which has lately been tried with complete success in the Navy, East India Service, &c. The following short description will render the subject quite clear; we must refer to the inventors for detailed particulars.

At the lower part of the capstan, a wheel (B) is firmly fixed, the cogs of which take into each link of the chain messenger for about half the circumference of the wheel, thus having a very powerful hold; and while, by an ingenious method of shaping the links, the cogs come into action in the most advantageous manner, the chain messenger is at the same time prevented from twisting round.

Two rollers (C C) support the slack part of the messenger before the nippers, and upon these it is carried round the fore part of the deck: these rollers being moveable in a slide on the block (D), allow the messenger to be brought to the required degree of tension. It is unshackled after use in the same manner as chain cables.

E. Shows the manger on the new plan.

F. The hawse holes.

G. H. Shows the cable connected as usual to the Messenger.

I. The fore-mast.

K. The main-mast.

L. The main hatchway.

M. N. Shows the mode of shackling the messenger.

The advantages of this messenger consist in its convenience for stowage, both as it respects room and time; its keeping the cable tiers always clear for use; the rope messenger in ships-of-war being stowed in the heart of one bower tier, and the spare one in the heart of the other, both of which must, therefore, be hauled on deck before the cables are ready for running. It requires no shifting; after one anchor is hove up, the other may be immediately *brought to*. It requires no *holding-on*, or *lighting forward*, nor any *lighting round the manger*; thus placing forty or fifty men and boys in a 74 at disposal for other duties. This point will prove a great convenience to the East India Service, who have full work for all their crew. The troublesome and dangerous operation of *surging* every three or four minutes while heaving-in, is entirely avoided; in fact, the official reports invariably state that no stop takes place from first to last, if the capstan is sufficiently manned. In addition to this it is to be noted, that by hanging the veering cable, in unmooring, to the chain messenger, it *rouses* it up the hatchway, and carries it entirely along the deck; by which the labour of thirty more men is saved in a line-of-battle ship.

In *surging for catting*, the cable only is stoppered *before all*, and it is then *surged* through the turns of the stopper. When this messenger is applied to their improved patent capstan, this department of nautical mechanism seems complete.

Messrs. Gordon and Co. have given in a Pamphlet all the details, accompanied by Official Reports to the Admiralty, &c. These Messengers have been lately fitted to the Alfred, Barham, and Hebé.

A POPULAR VIEW OF FORTIFICATION AND GUNNERY.

NO. IX.

Retrenched Camps.—There are few fortresses capable of receiving within their walls 20,000 or 30,000 men; indeed, such places would require an enormous expense, both in their construction and in their repairs, stores and garrison.

Vauban proposed to make fortresses of a moderate capacity, fit to serve as a shelter for an army or some divisions of an army, to aid in the general arrangements of a campaign, by forming a retrenched camp under the guns of the place. An enemy would not hazard passing such a retrenched army as 20,000 or 30,000 men, that would be on the alert to cut off his communications; and a single corps of observation would not suffice to hold such a garrison in check. This kind of fortification, as being between permanent and field, has been called *mixed fortification*.

Fig. 70 is Vauban's idea of a retrenched camp.

Fig. 70.

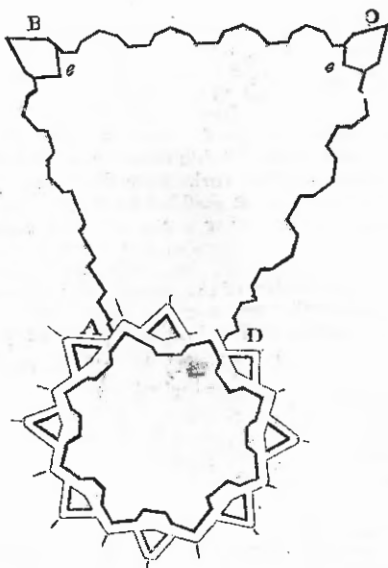

Its general outline ABCD forms as much as possible straight lines, in order that the salient points, which are most likely to be first attacked, may be reduced to the fewest possible in number. This tracing rests its base on the fortress; the profile should be bold; the parapets having at least nine feet and a half of height, and the ditches sixteen feet of depth, surrounded by a glacis, to cover part of the parapet and to heighten the counterscarp; every precaution usually taken to render

field-works secure from a *coup-de-main* should be adopted to strengthen these works.

The salient points B and C most subject to attack are strengthened by retrenchments *ee*; in these most exposed parts the bastion tracing is used as being the strongest; but a more simple trace will suffice under the guns of the place.

Frederick the Great shut himself up under the cannon of Seweidnitz with an army of 40,000 men, in a retrenched camp, constructed, not in a continued line of parapet, as in Fig. 72, but by lunettes at intervals; the angles of the general trace being defended by redoubts; so that he could freely move out when necessary to take the offensive. These lines were constructed in four or five days, and within them he defied the Allies triple his number.

Marshal Soult had an army of 35,000 men in 1814, which he most ably entrenched in a position around Toulouse. Colonel Jones says,

“This city presented many peculiar and great local advantages in furtherance of his labours, being surrounded by a defensible wall, three fourths of which are covered by the canal Royal du Midi, or by the Garonne, an impassable obstacle. Therefore to give that considerable portion of the circumference the strength of a moderate fortress, it was only necessary securely to cover the communications over the canal; and, being zealously aided by the labour of the inhabitants, he quickly effected this by fortifying various buildings and constructing field works of a stronger profile than usual. All direct approach to the remaining fourth of the enceinte not covered by the rivers, was interdicted by the state of the cross roads, being also flanked by a range of bold hills, the summit of which the French had strongly occupied by five redoubts, and had formed various lines of entrenchment in support of them, and to connect the flanks of the ground with the defences of the town. At the foot of the heights runs the river Ers, all the bridges over which out of the fire of the works were destroyed. Such was the advantageous position in which Soult decided to try the fate of arms. Yet it was carried by the Allied army under the Duke of Wellington on the 10th of April 1814. But as the operations of the day consisted entirely in the attack of formidable retrenchments, the loss of the victors was very considerable; probably exceeding that of the vanquished: above 4500 Portuguese and British having been killed and wounded, and more than half that number of Spaniards.”—See Jones's *War in Spain*, page 382, plate 4.

The same able Commander (Soult) has given us another instance of his opinion of the value of retrenched camps, in the works of this nature that he ordered to be constructed at Bayonne, from whence he was forced by the Duke of Wellington to retire to the position we have just mentioned at Toulouse. We still quote the words of our military historian Jones (vol. ii. of his *Sieges*): in speaking of Bayonne, he says—

“Soult had caused his troops to labour incessantly throughout the winter in strengthening and adding to the capacity of this frontier bulwark, and had formed an advanced line or entrenched camp nearly parallel to the ramparts, at 500 or 600 yards in their front. This advanced line of works being well supported by inundations and other natural obstacles, was of great strength, and covered sufficient space to enable the garrison to form unseen and unexpectedly attack with their whole force the works of the besieger, necessarily divided by the Nive, and may be considered to have given Bayonne on the left of the Adour, the strength of a first-rate fortress.”

Much has been said and written in favour of, and against, retrenched

camps; it is not a question for us to decide, whether a body of 20 or 30,000 men could be more usefully employed in active operation in the field than resting under the protection of the guns of a fortress, and occupying a strong position there; we speak only of *corps d'armée* driven to the necessity of such a measure by the circumstances of the campaign; when assuredly we may say with Napoleon, that although "There are military men who ask of what use are fortresses, retrenched camps, and the art of the engineer, we would ask in our turn, how is it possible to manœuvre with inferior, or even with equal forces, without the aid of positions, of fortifications and all the supplementary means of the art?"* Besides, should it be advisable to evacuate a retrenched camp, the original strength of the fortress is not at all diminished thereby. Even a grand army composed of the vast numbers that have taken the field in our last war, might benefit by the support of a fortress on which to rest one wing, as in Fig. 71,

Fig. 71.

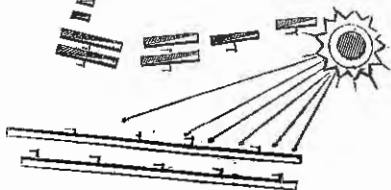

while the most efficient divisions of the army are placed on the other wing, advanced towards the side susceptible of attack. Had the confederate army that advanced from the Apennines in 1512, to relieve Ravenna along the right bank of the Ronco, adopted this self-evident proceeding, the result of that campaign might have been very different. Ravenna stands on the left bank of the Ronco, at three miles distance from the sea, on which side the French besieged it, while it was gallantly defended by a Spanish garrison. The confederates advanced by the right bank, and it might naturally be assumed that they would have passed by the besieging army on the opposite side of the river, entered the city, and supported by it, formed an entrenched camp in a formidable position; instead of which they halted short of Ravenna, on arriving within sight of the French army, covered their front by a trench, and resting their left flank on the Ronco, offered battle; which the French, in their desperate circumstances, eagerly accepted under their ardent young leader of twenty-two years of age, Gaston de Foix, and crossing the Ronco in presence of the confederates, attacked and defeated them.† In speaking of points of support in the environs of fortresses to favour the manœuvres of an army upon the defensive, and between which it can change front without danger to meet the enemy on whichever side he may present himself; Gen. Rogniat in his work entitled "Considerations on the Art of War," says—

"I see no better manner of fulfilling these conditions than that of esta-

* Conversations de Napoleon, par Montholon.

† See Colloquies with Folard, U. S. Journal for October 1830.

blishing four little forts around each place, forming a great square, in the centre of which is the fortress as in Fig. 72. Fig. 72.

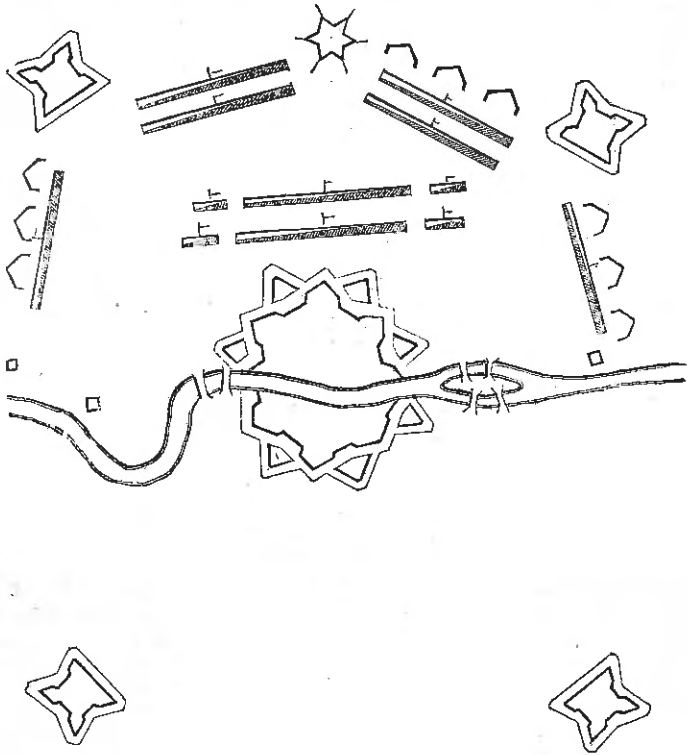

These forts should be established on the summits of the most advantageous heights, at about 2400 or 3000 yards from the works of the place, and about 6000 yards from each other; the space comprised between two forts would form a field of battle capable of receiving from 50,000 to 100,000 men, and might be looked upon as impregnable; the forts, armed with heavy guns, would perfectly support the wings, and the centre could be strengthened by field-works constructed at the moment of need. Thus, the four forts circumscribing each fortress, would form all around a vast retrenched camp, presenting four fronts or four different fields of battle, so that face could be made against the enemy on whatever side he presented himself. The ordinary guard of this retrenched camp could be reduced to that necessary for the four redoubts, which could not be more than 800 men; the fortress itself serving as a depôt for the subsistence and re-organization of the army. It is easy to vary the disposition of fortification according to the nature of the site of each fortress, to adapt it to the ground, and to profit by natural positions."

The good defence of Dantzic in 1813 by the French army under Gen. Rapp, shows the advantages arising from the foregoing dispositions; the following is an extract from an interesting relation of this siege by Capt. d'Artois.

"The mode of exterior defence presented many advantages. It secured

great resources in provision, in forage, in materials, in workmen furnished by the suburbs and villages that we occupied. The inhabitants themselves (whose rising we sometimes feared) formed a good opinion of an army that was not hid within the walls of the place, and hence put more confidence in it; or at least were kept more to their duty by the idea that they had of its power. Let us suppose that an enemy endeavours to reduce the siege to a species of blockade, or small partial sieges, the defenders, having the advantage of a knowledge of the ground, can secure all their positions by fortifying only some points. In this manner they keep the enemy at a great distance, and force him to make such an immense development as must render him weak.

"It is desirable that we should seek more than we ordinarily do, to prevent the establishments of lines of countervallation,* or at least to oblige the enemy to construct them at a great distance. The more ground that is occupied, the more easy it will be to have some point to beat the enemy in detail, or to revictual the place. Let us hope that the example given at Dantzic will not be sterile, and that it will serve to confirm the excellent principles expressed by Mons. Carnot in his work on the defence of fortresses, where he recommends that the suburbs should be preserved and fortified for defence, in place of being destroyed on the approach of an enemy, which is too often the case.

"Let us remark, that this is not in opposition to the adopted maxim *to raze all that obstructs the view within the range of cannon*; for after having held the suburbs, hamlets, isolated houses, &c. as long as possible, precautions can be taken to destroy such cover as may be favourable to the enemy, when necessary to abandon it: at least, when forced to take these painful steps, all that depends upon us has been done to avoid bringing such disasters on the inhabitants. This is what occurred at Dantzic, when we were obliged to abandon the suburbs of Ohra and Schidlitz, which were preserved whole as long as we could occupy them. By this distant defence we retarded the bombardment."

"It appears clear to us, that in every respect it is right to keep the enemy as long as possible at a distance from the ramparts: to effect which, all sacrifices should be made, in order to increase the *morale* of the garrison and of the inhabitants, resources of all kinds, the facility of sorties, and the valuable retarding of those incalculable evils that necessarily overwhelm a city exposed to the fire of batteries of all kinds."

How many even amongst military men have subscribed to the maxim expressed by Voltaire in his *History of Charles XII.* that—

"Troops attacked in their retrenchments are usually beaten, because those who attack have always an impetuosity that those who defend themselves cannot have; and waiting for their enemies in lines, is a confession of weakness and of an enemy's superiority."—

A reflection arising from the successful assault made by Charles XII. on the Danish retrenched camp before Copenhagen; but it may be presumed that Voltaire's mind was not uninfluenced by the event which he very soon afterwards relates of the attack made by Charles with only 8000 Swedes on three Russian lines, the first of 5000, the second of 20,000, and the third of a retrenched camp defended by 80,000 men and 150 guns, all three of which he completely overthrew. Yet a calm examination of the circumstances accounts for this extraordinary success, (as much as it is possible to account for some of the

* To invest a place means to surround it in such a manner as to prevent its holding any communication with the country: the attacking army sometimes secures its camp by forming it between two sets of fortified lines; the one called that of *circumvallation* facing the country; the other, that of *countervallation*, facing the place.

events of the military career of that extraordinary monarch): for such was the undisciplined and wretched state of the Russian army, that when they besieged Nerva in 1700 with 100,000 men and 150 pieces of artillery, and which was defended by Baron de Hoorn and only 1000 Swedish regular troops, the besieged resisted six weeks till relieved by Charles XII., whereas the little city of Nerva ought to have been reduced to cinders in one sixth of that time.

As soon as Charles had taugth his adversary, Peter the Great, the art of war, he was ruined in his attack upon the retrenched position of the Russians before Pultawa, in July 1709, although he then led 16,000 Swedes and 5000 Cossacks against the Russian lines defended by 70,000 men and 72 pieces of cannon; on which day Charles lost the fruit of nine years victory and of one hundred combats.

That there is much truth in the maxim just quoted from Voltaire, the page of military history fully proves; but it is not the whole truth, and no just maxim can be founded on partial truth. It would lead us away from our object, were we to follow the field that this subject opens to our view; but we beg to recommend the perusal of Colonel Jones's interesting and instructive memoranda relative to the lines of Torres Vedras, thrown up to cover Lisbon in 1810, as by far the most able work that has ever been written on the just use of field-works. If, as Napoleon said, "the principles of field fortification have need of being perfected, and this part of the art of war is susceptible of great improvement," there is no living engineer more qualified than Colonel Jones to point out the means to effect this improvement; at all events this little volume serves to show that the troops waiting in their lines at Torres Vedras was no proof of their weakness or of the enemy's superiority.

Detached Works.—It is evident that a single work so situated as to render all approach to it difficult and dangerous, must be of great value in covering the front or fronts adjoining it. But it is difficult to give any minute directions respecting such works, as their construction and value must solely depend on their inaccessibility, either from being situated on a rock or surrounded by an inundation or a marsh. If in low marshy ground, the principal faces of such a detached work should, if possible, be directed either on the main works or upon some obstacles, so as to prevent an enemy aligning himself with their prolongations to enfilade them; and while the guns of such a work should command all the approaches to it, the embrasures should not admit of enemy's batteries firing directly into them to dismount the guns. Detached works (usually) are necessarily small, consequently good bomb-proof cover is absolutely requisite to prevent their being readily reduced by bombardment; but, above all, it is of the utmost importance to be able to carry succour to the advanced work by a sure and covered communication.

We have examples of detached works open at the gorge, and enclosed all round; depending on their distance from the main works of the place. If open at the gorge, the whole of the interior should be exposed to the fire of the place: generally, however, detached works are redoubts or forts, that is, works enclosed all round. On a flat dry space in the middle of a marsh at Menin, there are two horn-works, the one placed beyond the other.

At Namur, the heights are occupied by strong redoubts within the range of each other's fire.

Fort Christoval occupies the summit of a rocky height at 500 yards distance from the fortress of Badajoz, from which it is separated by the river Guadiana, (it is an irregular square fort, see Jones's Sieges, plate I, vol i.) This fort offered a good and successful resistance when defended by the French against the Allied army under the Duke of Wellington: First, from the 8th to the 12th of May 1811, when the besieging army marched out to meet Marshal Soult, who approached with the intention of relieving Badajoz, and which brought on the sanguinary battle of Albuera on the 16th of May; secondly, on the return of the army to resume the siege of Badajoz on the 29th of May, when twenty-three pieces of artillery were placed in battery against Fort Christoval (its figure occupying only a square of 300 feet): it was partially breached and unsuccessfully assaulted on the night of the 6th of June. On the 9th of June, the Allies were again foiled in a gallant attempt to storm the breach; and on the following morning the siege was raised.

Here we see the importance of a well-situated detached work, difficult of access; for Christoval is constructed on such rocky ground as to afford little or no earth to cover the besiegers; its good defence greatly hampered the means of attack on the main-works of Badajoz.

The detached lunette of Picurina at Badajoz (see vol. i. plate 4, Jones's Sieges,) offered a good resistance by the same garrison in 1812, in the successful attack by the Duke of Wellington's army. The attack commenced on the 17th of March, and the Picurina was gallantly carried on the night of the 25th March. Picurina is a work shaped like a bastion, having two faces of 200 feet each, and two flanks of 70 feet each; also a covered-way and glacis, and closed at the gorge by a slight earthen breast-work well palisaded: it occupies a height about 400 yards from the main-work, from which it was then separated by a temporary inundation of the stream Rivillas.

It is of importance to dispute with an enemy every post capable of defence without the place; and even strong buildings often afford the means of doing so: for instance, the French garrison that defended St. Sebastian in 1813, occupied the convent of St. Bartolomeo at about 700 or 800 yards in advance of the works of the town, and on the isthmus, which they strengthened by a small redoubt: when besieged by the Allies under the Duke of Wellington, a period of six valuable days was occupied in reducing it, causing an expenditure of 2505 18-pound round shot, 19 18-pound grape, 331 8-inch shells, and 143 6-inch spherical shells.

Remarks.—It appears from the foregoing properties of *retrenched camps and detached works*, that an inferior army on the defensive can seldom fail to find a formidable position on which to defend a town or place of consequence: no doubt a fortified place will afford better support to such a position than an open town; but still it appears that much may be done by a zealous and intelligent co-operation of the civil and military authorities of a nation when united against an aggressor. So far has this opinion been carried, that it has been asserted that it is quite needless to expend such immense sums of money on the construction of the regular works we have described as constituting the

defences of a fortress; and that it will suffice to throw up strong forts around a place, (as shown in Fig. 72,) and connect them by lines of field-works in the day of need. Like most novelties, this has been pushed too far. To defend extensive positions covering large towns, great bodies of disposable troops and a national interest in the war, are requisite: and when such a position is forced at any one point, what impediment is there to the destruction, pillage, and ruin of the town it was intended to cover? History attests the value of good fortresses, which have been, in many cases, the salvation of a state.

In our insulated position, as a great maritime nation, it may be remarked, that our great dock-yards and arsenals being our most valuable depôts and positions, this mode of keeping an enemy at a distance from them is of vital importance. The range of shells thrown from mortars averages from one thousand yards to upwards of two miles. An enemy, therefore, who can establish a number of mortars within that distance of a dock-yard or arsenal, would very soon totally destroy it, without any other proceeding. Hence the absolute necessity of constructing strong posts within range of each other around depôts of a nature so easily destroyed; a system of defence that we see has been partially followed at our first great naval depôt and dock-yard.

THE THIRTY-FIFTH REGIMENT.

LETTER OF KING CHARLES OF SPAIN TO QUEEN ANNE.

MR. EDITOR,—I herewith send you the following interesting letter I have lately found, which was written by Charles King of Spain to Anne Queen of England, respecting the gallant behaviour of the 35th regiment of foot, and the death of its Colonel, Earl Donegal, in 1706. It appears that the 35th was raised at Belfast, in Ireland, in the year 1701, at the sole expense of the then Earl of Donegal; and made a present of to King William, (their facings are orange,) who appointed him Colonel of it, and sent the regiment out to Spain, to defend the rights of the House of Austria, and the Earl, with twelve of his grenadiers, was the first who set foot on shore. His Lordship was made Major-General of the Spanish forces in the year 1704. The regiment was for many years called the Belfast Regiment, and the ground in Belfast where they were first drawn up, is to this day called the Parade.

27th June 1831.

B.

(COPY.)

“Madam, my Sister,—It is always with the utmost satisfaction that I do justice to those worthy persons who signalized themselves by their conduct and valour in your Majesty’s service and mine. My Lord Donegal was remarkably so when alive, and his brave regiment the 35th of foot, and more particularly at the last siege of my city of Barcelona, both in his quickness in succouring it from Gerona, and the long valiant defence he and his brave regiment made in Fort Montjuic, where he lost his life in the assault; and it is in a great measure to his memory and gallant regiment, that I am indebted for the preservation of that capital, and it may be for all the possessions I now hold in Spain.

“I shall injure your Majesty’s usual generosity, by offering to recommend to your favour the family of so worthy a gentleman, and also the officers of his brave regiment; for I know your Majesty’s inclination to it; I will only add, I will place all the marks of favour and acknowledgment which your Majesty will please to bestow on the family and the regiment to my own account, as well as the remaining obligation.

“I am, with sincere gratitude and love,

“Your Brother,

“Madrid, April 15th, 1706.

“CHARLES.”

RIFLE CARTRIDGES,
WITH OBSERVATIONS ON RIFLE PRACTICE.

BY COLONEL MACERONE.

I PRESUME it will not be denied that the efficacy of light infantry, in skirmishing, mainly depends on the effect of each individual shot.

It has been sufficiently demonstrated, that a smooth barrel, such as the common musket, will not propel a bullet with any degree of accuracy even the short distance of fifty or sixty yards. Hence in most European armies, the light troops or skirmishers have been armed with rifles, which giving to the bullet a rapid rotation on the axis of its flight, its unequal friction in the barrel, and the unequal resistance of the air to its unavoidably imperfect sphericity, are continuously rectified during the whole course of its flight.

The only objection to the use of the rifle, as hitherto managed, and which has been held sufficient to exclude its use from the French armies during the whole of the late war, is the inconvenience and loss of time experienced in loading it—the powder and ball having to be introduced separately, and it being indispensable, that the latter should be enveloped in a piece of greased tissue, to facilitate its descent into the barrel with sufficient constriction to force its substance into the spiral grooves from which it receives its rotation.

After various experiments, I have found that with the cartridge I am about to describe, a rifle may be loaded with, at least, the same precision and efficacy as by the present inconvenient practice, but, at the same time, with very nearly the ease and rapidity of a common musket.

I also exhibit a method by which common carbine or musket cartridges, (provided they are of the proper caliber,) may be expeditiously converted into rifle cartridges.

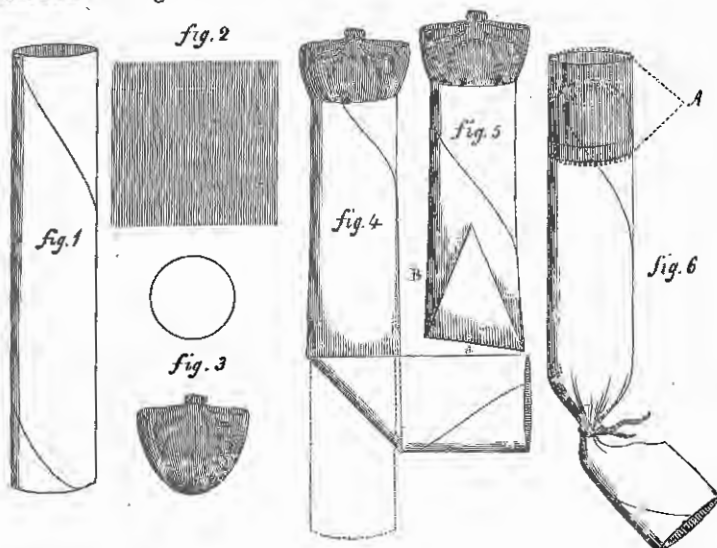

Fig. 1. Represents the common paper case, made on a mandrin,* which has its end well hollowed out. Upon the paper being rolled, turned down and touched with glue, the concavity is perfected by pressure upon a bullet.

Fig. 2. Is a bit of cotton tissue, of a thickness analogous to the more or less precise agreement of the calibers of the bullet and the barrel. It is a

* Mandrin is the French name of the stick upon which cartridges are made.

square of two diameters of the bullet, and can be expeditiously made in great numbers, by tearing the calico into strips of the requisite breadth; when a dozen strips placed one upon the other, may be cut simultaneously into squares with a chisel.

Fig. 3. The bullet enveloped in the square of calico; secured at the corners by a couple of stitches, or a touch of glue.

Fig. 4. The concave end of the paper case being touched with glue, the enveloped bullet is placed upon it. I find that it is better to glue the cotton on to the paper-case *previously* to stitching in the bullet.

Fig. 5. The above being dry, and the powder introduced, I would recommend the folding up represented at A, instead of the ligature at present used; for even without a touch of glue at the edge B, this fold forms a very secure closing, and is easier than the ligature to tear off with the teeth, by a gentle turn of the hand, without any jerk or loss of powder.

The rifle cartridge, to be completed, passes to another hand, who with a brush, or in any other convenient way, gives to the cotton cover of the bullet the necessary greasing.

It is superfluous to point out, that the resistance of the air to the open ears formed by the folds of the cotton, detaches it from the bullet, on the instant of its expulsion from the barrel.

Fig. 6. Represents an ordinary carbine hall cartridge, converted into a rifle one, by a bit of calico being slightly pasted or glued around the bullet end, and afterwards greased as above. Care must be taken not to apply so much glue, or paste, as will cause it to penetrate through to the exterior surface of the calico, which is to receive the greasing. The latter method is only recommended as a "makeshift," being very inferior to the other above described, the stiffness of the subjacent paper, preventing the bullet from entering the grooves of the barrel without an inconvenient application of force. This defect may, however, be partly obviated by tearing off the paper from around the bullet, with the exception of only one circumference, previously to applying the calico.

I have made many experiments and thought a good deal, by way of ascertaining the best caliber for answering the *particular* or *general* purposes to which the rifle may be applied. We all know that the resistance of the air is the chief obstacle which projected bodies have to encounter; it is so very great, that the range of projected spheres is more regulated by the degree of this resistance than by the velocity they receive from the powder; the increased velocity of the ball being met by a geometrically increased ratio of atmospheric resistance. The larger bullets, therefore, having less surface in proportion to their mass, are proportionately much less resisted; so that the flights of the larger exceed those of the lesser, in more than the proportion of their respective diameters. For instance, a 32lb. shot, whose diameter is about six inches, will, with even a less proportionate charge of powder, and at an equal elevation, range half as far again as a 9lb. whose diameter is four inches. The proportion which the surface of a sphere bears to its mass, increasing in a geometrical ratio to the decrease of its diameter,—the smaller the sphere, the greater is the proportionate resistance it meets with in its flight. At length we find that small particles of the heaviest metals, becoming, as it were, nearly all surface, will actually float in the atmosphere or remain suspended for a considerable time in the lightest fluids. Hence it is, that from the same piece, and with a similar charge of powder, we shall find that the range of an ounce of bird-shot will regularly extend with the increased size of the shot employed, until, in progression, we get to the ounce bullet itself, which fits the piece; and which, by the by, at an elevation, would not be impelled further if projected from a 24 lb. cannon.

The theory of the air's *regular* resistance to the onward progress of the bullet, must also be applied to the *irregular* action of the wind *across* the line of its flight; which action also increases in the ratio of the decrease of

the weight of the bullet. At the distance of 315 yards, I have found a strong cross wind to cause a rifle bullet of nineteen to the pound, to diverge from three to four feet. On the other hand, I have used a rifle carrying a bullet of eight to the pound, which, with the same wind, did not, at the same distance, diverge more than about *one* foot. In constructing a butt for rifle practice, regard should therefore be had to the more usual direction of the wind;* and as far as the locality will allow, the butt should be placed so as to have the wind more frequently in the line of the range either way, than across it.

For general, and especially for military purposes, such large rifles as the last mentioned would, coupled with the ammunition, be found too heavy. The rifles commonly used in the United States, carry, I am told, a bullet of thirty-two to the pound. The adoption of so small a caliber, I take to have been occasioned by the use of the rifle being, in that country, originally and generally confined to the interior of thick forests, wherein it seldom happens that an object is to be fired at beyond the distance of one hundred yards; and where, moreover, the wind is much less felt than in the open country.

Under the above circumstances, the half-ounce rifles are quite adequate to their purpose; but, in a more open, and especially in a mountainous country, the caliber of rifles should be considerably larger. In a hilly country, you are often in actual presence of the enemy, and capable of greatly annoying him, at distances at which, on a plain, the view is interrupted and confined by the least considerable of surrounding objects. In a hilly country, occasions are perpetually offering, wherein long rifle ranges would cause considerable mischief to your opponents. Such long ranges can never be obtained, or depended on, with the half-ounce rifles of the Americans and Tyrolese.

If the foregoing observations are founded on facts, it is easy to decide what sort of rifle should be applied to a *particular* purpose. With respect to *general* purposes, I am inclined to fix on the caliber of one ounce, or sixteen bullets to the pound. The English Government rifles are of nineteen or twenty to the pound, to which caliber there is little objection; especially as it is the same as that of the cavalry carbines and pistols. However, I could advance several reasons—I do not call them *very* important ones—for preferring the French regulation, according to which, all the fire-arms of all the different corps, both of cavalry and infantry, are of one and the same caliber, of sixteen bullets to the pound.

With respect to the rifle at least, I would most strenuously recommend the substitution of percussion for flint locks, over which the advantages of the former are as great, as the latter are superior to the huge wheel and pyrites locks of two centuries ago. In comparison to the percussion gun, the very best flint one absolutely hangs fire, and one out of nine is usually a *miss-fire*. A cap is put on much quicker than a flint-lock is primed; there is no time lost in changing flints, and if Mr. Joyce's percussion powder be used, there is no foulness or corrosion whatever; lastly the rifles at present in use might be converted into copper-caps, at a trifling expense,† and new

* Inmost parts of England, north-east and south-west winds endure for about seven-eighths of the year.

† I have invented a simple and efficacious method of rendering copper-caps perfectly water-proof. It consists in dipping the open rim, or base of the cap, into tallow and rosin, melted in a plate over a lamp. The melted composition must not be so deep as to spread into the cap up to the percussion powder at its extremity, but only so high as to form a slight lining of the tallow around its inner base. This will suffice to cause the cap to close hermetically over the nipple; so that, provided it be not cracked, and the gun have no lateral vent-hole, (which it ought not to have,) the loaded piece may be put over the lock into a pail of water, without affecting either the cap or the charge. For sporting purposes, it is sufficient to have a few such caps in store for wet weather. For military use, the whole of the caps might be so prepared at the laboratories.

copper-cap locks will cost less than flint ones. The only objection to the change, (and I own it is a very great one indeed,) is the *blind prejudice of custom*.

To render the use of the copper-cap piece still more eligible, especially for military purposes, there should be no lateral vent-hole in the breech, but, in lieu of it a broad convex-headed screw, which upon being withdrawn opens a passage into the chamber under the nipple of an eighth of an inch diameter. By this simple contrivance, which I have applied to all my own guns, rifles and pistols, should any obstruction occur, either from wet or dirt, which cannot be removed by merely probing the nipple, it will infallibly be cleared out by removing the screw, scooping out the passage into the chamber, putting a little powder therein, and firing it off, after having probed the nipple and replaced the screw. The aperture formed by the removal of the screw, greatly adds to the facility of washing the barrel.

Instead of the brush and brass wire-pricker required for the present flint-lock service, the use of percussion pieces would make it necessary to substitute a little instrument of steel resembling the figure †; one half of the horizontal part being a four, or, what is perhaps better, a three-sided pricker, or probe, of about one-twentieth of an inch diameter; the other half of the horizontal piece, forms a kind of little scoop, corresponding to the diameter of the lateral screw above mentioned; upon the removal of which it is to be employed. The centre piece, or foot of the †, is a turn-screw, surmounted by a little ring, to attach it to the jacket. As, however, the instrument will not be often wanted, perhaps it had better be kept in the trap of the rifle-stock, in the inside of which I attach it, by a thong, to a little screw staple.

Some persons recommend, that instead of the lateral screw above described, the nipple itself should be taken out, in case of obstruction, or for the purpose of washing the barrel. This is not only ineffective, but highly improper, as it requires the use of a particular-shaped key, or pincer, to unscrew the nipple—whereas such things as will turn a screw, or serve the purpose of a pricker, are to be found everywhere.

The percussion powder for the caps should by all means be composed of the nitrate of mercury, first brought into use by Mr. F. Joyce, of Old Compton Street. This, instead of having the slightest tendency to corrode the piece, would rather appear to possess an anti-oxidating property; for I have repeatedly found, that having fired upwards of twenty rounds with this percussion powder, and laid the piece by for a month without the least cleaning—it has been, at the expiration of that time, as perfectly free from the least speck of rust, as the day it came new from the maker's shop. This would certainly not be the case even with a common flint-lock; but as for the common percussion powder, composed of superoxygenated muriate of potash, it actually corrodes the parts of a gun as much as a drop of nitric acid itself; in fact, upon combustion, it evolves, and leaves a residuum of that active fluid upon the iron. The consequent rapid destruction of the parts is such as would, especially in military service, occasion great inconvenience.

I have often compared notes, and reflected upon the respective advantages belonging to the magazine and copper-cap locks, either for military or sporting purposes. Of magazine locks hitherto invented, the best and simplest is that by Forsyth, with the magazine sliding upon a plane, in which is the touch-hole, being connected with the cock by a bridle, which causes it to follow or precede its motions. For military use, this lock has the advantage over the copper-cap, inasmuch as it saves the time and attention required for priming; nothing else being required than to cock and pull the trigger. In rifle practice, the use of this lock will more than retrieve the small additional portion of time which it requires to push down even my rifle cartridge, above what it takes to drop a cartridge into a common musket, with all its windage. On horseback, the advantages of such magazine locks are still more evident and important; as every one knows what an awkward loss of

time and powder the operation of priming a flint lock occasions to a horse-man in motion; whereas, with the magazine, containing thirty or forty primings, and a swivel ramrod, a carbine or pistol may be loaded with the same speed and precision on horseback, at a trot or a gallop, as when sitting still in a chair. It is certainly easier to put on a copper-cap than to prime a flint-lock; but, with the magazine, there is no priming operation at all. With the common corrosive percussion powder above spoken of, the magazine-lock certainly becomes very unfit for military purposes; for after having fired a shot or two, without subsequent cleaning, the lock will be nearly immoveable the day after. However, in the late Spanish campaign of 1823, I had several magazine rifles and pistols, and no other than the corrosive percussion powder; but the officers and men to whom I entrusted them, were so proud and so careful of them, as to keep them always in the most perfect order. Any how it is evident, that for cavalry *officers* at least, the percussion *magazine* locks are undoubtedly to be preferred; and for both officers and men, I will observe *en passant*, that it is far better to have one double pistol, than two, or half a dozen single ones; and that, whether one or two pistols be used, they should, upon going into action, be secured by a thong to the sword-helt, so as, in case of need, to be instantly disposed of by being dropped over the left shoulder. By having only one pistol, one holster may be converted into a convenient pouch. It is essential, that in double pistols, carbines, or rifles, the axis of the barrels should be perfectly parallel from breech to muzzle. If this be strictly attended to, it is not of much consequence whether they be disposed as in a fowling-piece, or, as it is called, "under and over." One "under and over" pistol, eight inch barrels, (the upper one rifled,) nineteen bore—swivel ramrod,—with a moveable spring butt, to be kept in the other holster when not in use, is an excellent weapon for an officer. The moveable butt must also serve the purpose of a mallet in loading the rifle barrel. Three or four slight taps will send the ball home; for, particularly on horseback, a rifle-barrelled pistol cannot well be loaded by pushing with so small a ramrod. With the smooth barrel, the party may fire away, either with ball or my buck-shot cartridges, described in the next section and drawing, as fast as he pleases.

The copper-cap offers the advantage of somewhat greater simplicity, and consequent less liability to derangement; and above all, it is, with the application of tallow and rosin above described, *perfectly water-proof*. For the rifle military service, therefore, it might perhaps, in one point of view, be preferable to the magazine; and certainly it is so, in every respect, for fowling-pieces; in the use of which, protection from the rain is of much more importance than the gain of a few seconds in loading, and where none of the inconveniences of priming on horseback are experienced. Duelling pistols should decidedly be copper-caps. With such pistols there is no occasion whatever for a magazine; and I have found that a delicate trigger cannot be subjected to the slightest casual pull or strain of the magazine stirrup without great liability to accident.

A remarkable defect in all the rifle-shooting that I have ever seen is, the improper construction of the ramrod, which is much too light. From this it results, that, either the bullet is inserted with too little constriction to ensure its revolving on its axis to the end of an *extensive* flight; or upon a tighter fit being attempted, much time and awkward exertion are expended in driving it properly "home."

The friction to be overcome in forcing a bullet into a rifle is, in some respects, analogous to that of a wedge or a nail in entering a piece of wood. Nobody would think of driving a nail or a wedge by mere *pressure* or *pushing*, which would not effect the object with a thousand times the force that would suffice in the shape of percussion or impingement.* To load a rifle

* From experiments made in Portsmouth Dock-yard it results, that a man of medium strength, striking with a mallet weighing eighteen pounds, and the handle

with a mallet is out of the question, especially for military purposes; but I find that the very best effect is produced by having the ramrod of solid brass, considerably heavier than the iron ones of the government rifles. I have also a bit of hard wood, turned into the shape of a pestle, acutely convex at the thick end; and to qualify it for hasty use, I fasten it by a string to the button of my jacket. With this I give the ball a smart tap, which drives it below the centre of its circumference, into the grooves of the barrel. If the latter be perfectly clean, the bullet will go down all the way by mere *pushing*; but this will not be the case after a few shots have been fired, unless the bullet be smaller than it should be. Any how, the ramrod ought always to be *flung* down once or twice, in conclusion; as the particular *ring*, and *jar*, so produced, furnish the only true criterion of the bullet being really "home."

The ramrod being of the proper weight, and the end applied to the bullet being nearly equal to its caliber, and well countersunk, the bullet will be moved by it with a few easy percussions; and should the barrel be ever so foul towards the breech, one or two *flings*, with such a ramrod, will send the bullet "home" with the assured ring. Neither a wooden nor a light metal ramrod will produce this effect after a few shots.

The ramrods I have had constructed for my own use are of solid brass, of about half an inch diameter, except the end applied to the bullet; which for a couple of inches is so large as just to fit easily into the barrel. This large end is bored conically out, so as to contain between two and three drams of powder, which in leisure shooting serves to introduce the charge with the rifle reversed. The ball-drawer, when required, screws into the other end of the rod.

The government rifle ramrods might, for economy's sake, be made of iron; but they should be much heavier than they are. *It is absolutely necessary to good and quick rifle-shooting that the bullet should be driven into the mouth of the piece, by a stroke of some sort or other, previously to the use of the ramrod.* Should the little wooden pestle mentioned above be deemed inconvenient in military practice, which I opine it is not, a similar effect might be produced by a tap with the round button-like end of the present rifle ramrods; though for the sake of the barrel I would recommend that this button should be of soft copper. Were it made more convex, it would drive the bullet further in.

It is evident that for actual service the practice cannot be rendered too simple; so I only just mention, *en passant*, that in my own cartridge-pouch, twelve cartridges to be used first, are made with thicker cotton, which, for distinction's sake, is red or blue. So, as the barrel becomes foul, I get to the other cartridges, of somewhat easier introduction. I have found it very pleasant even to divide my cartridges into *three* different fits—red, blue, and white. A rifle, however, deteriorates in accuracy of shooting, in proportion to the number of shots fired without cleaning the barrel. For the foulness accumulating mostly towards the breech, forms there a certain degree of constriction and obliteration of the grooves, into which part the bullet being forced, no longer fits the other and greater portion of the barrel, so as to ensure its spinning upon its axis to the end of a long range. After twenty-five shots, without cleaning, at 315 yards, in very dry weather, I have found the bullets begin to deviate a little, as they no longer struck the target on the side which had come foremost from the barrel.

With respect to the rifleman's cartridge-pouch, it should certainly be placed in front, buckling round the waist with a broad strap. The great thickness or projection which is given to the English rifle pouches has many inconveniences, one of which is, that the weight being concentrated into one

of which was forty-four inches long, would start a large iron bolt, about one eighth of an inch every blow; but that it requires a *pressure* of one hundred and seven tons to press the same bolt down the same quantity; though a very small additional weight pressed it quite "home."

almost cubic mass, causes gréat fatigue and annoyance, and, perhaps, injury, to the bearer. So far from having any such shape, I have found that the pouch ought to be so flat as only to contain *one* row of tin tubes for cartridges, twenty-four of which occupy a space of about fourteen inches from hip to hip.* The tubes being about five inches long, open at each end, but divided in the middle by a diaphragm, contain two cartridges each. When the uppermost row is consumed, to get at the others it is only required to draw out the tubes, and reverse them in the pouch. If the cartridges are closed up, according to the method recommended, (Figs. 4 and 5,) they may, from the increased diameter of the folded end, be made to stick more or less firmly in the reversed half of the tubes when these are drawn out to be turned. The pouch covers up with a flap of flexible leather, saturated with linseed oil, and secured at pleasure with a round button and loop. At one or both ends of the pouch is a little leather bag, which may contain one or more packets of spare cartridges. I prefer, however, the method I have observed amongst the Calabrians and Corsicans, who, had they rifles, would be the most formidable skirmishers in the world. Their pouches go all round the body, though sometimes it is, as it were, a double pouch, with only small intervals at each hip, occupied by a bayonet on one side, and a middling-sized pistol on the other. From having only one row of tubes, these pouches are so little protuberant, as to be scarcely more perceptible, under or over the jacket, than a simple belt would be. When the cartridges are exhausted in front, the pouch is easily slipped round as much as required. Moreover the weight being so distributed all round the body, gives scarcely any incumbrance; and I have found it a further improvement to partially support it by hraces, worn under the jacket or waistcoat. Slips from the usual trowser suspenders will answer the purpose.

I must yet add a few words, by way of recommending some essential alterations in the method of exercising the troops to the use of that weapon, which will in most respects apply to the musket, carbine, and pistol.

In all the rifle or musket practice that I have ever seen or heard of, the men are made to fire at a target of about three feet diameter, *placed before a bank or mound of earth, which receives all the missing bullets!* Nothing can be more ineffectual in the way of instruction than this method! Every shot which misses the target might as well have been fired vertically in the air, for any instruction it can have afforded to the firer! Even those bullets which *do* strike the target, will furnish no precise criteria of experience, unless the actual mark of each be immediately pointed out to the man who fired it.

The butt, or rather wall, for teaching rifle or musket shooting, should be at least twelve feet square, or rather twelve feet broad and twenty high. It should be covered entirely with cast-iron plates, of about three-quarters of an inch thick. A convenient moveable butt may be composed of a rectangular frame of wood, traversed like a window-frame, by pieces of wood, at right angles or diagonally, having holes at the intersections for the admission of flat-headed bolts, by which the four corners of the cast-iron plates, corresponding to the size of the square divisions, will be secured to the frame, in close connexion with each other. Such a butt being set up endways, need only be connected, by a pulley at the top, to a couple of poles fixed in the earth, or to the top of a moveable triangle. Any inclination either forwards or backwards may be given to it by means of the pulley. If it be inclined backwards at an angle of eighty to eighty-five degrees, the bullets, at medium and short ranges, will be reflected upwards nearly perpendicularly in the air.

The ground, in front of the butt, should be well levelled to the distance of about thirty yards, and covered with sifted road-scrappings, in preference to turf, gravel, or sand.

* Supposing the rifle-bullet to be nineteen to the pound, and allowing to the cartridge two drams of powder, which, with a percussion rifle, of the proper weight, is enough for good shooting at *four hundred yards*.

As unnecessary waste should in all cases be avoided, there is no reason why the recovery of the bullets should not be attended to. The best way to ensure this, is to give to the surface of the butt an inclination forward of about ten degrees upon the horizontal line, which will cause the bullets to be reflected downwards upon the smooth ground in front. The recovered lead might be given as the perquisite of the "marker," or to the best shot at the drill.

A little on one side, and about five yards in advance of the butt, there should be a little screen or epaulement, behind which a man might safely stand to perform the office of "marker." This marker must be provided with a pot of lamp-black and water, with a brush affixed to a long stick, and a pot of whitewash. He must also have a bit of chalk, or box of various-coloured wafers, to mark the shots. To prepare the butt for shooting, it must be blackened all over. An object is then to be designated in the middle, either with whitewash, or with one or more sheets of white paper, according to the distance, and to the proficiency of the men who are to practise.

Instead of a circular object or target, I recommend for military practice, a perpendicular parallelogram of two, four, six, twelve, or more inches, broad, and one, two, three, or five feet high. If such a figure be made with whitening on the black butt, the bullets will make very distinct black marks upon it, while those which miss it, will leave white ones on the butt. If paper be used, care must be taken that it be not moved about by the wind. Pieces of thick sheet-iron, of the shape and dimensions last described, to suit the different distances, &c. whitened and hung up against the butt, form excellent targets, especially for distant shooting. A loud gong-like clang announces the stroke of a bullet, while the marker may pretty well indicate, with a white stick blackened at the end, its precise situation. He will also point out the site of those unresponsive shots which do not hit the mark. The presiding officer should use a telescope. This method will obviate the necessity of perpetually walking up to the target, which occasions much loss of time, confusion, and danger.

As I have always observed, that it gives most satisfaction to the firer when he sees the object fired at actually knocked down from its situation, this result might easily be obtained either with plates of plaster of Paris, or with metal ones. It may be also well to observe, that a bright red is undoubtedly the colour which can be seen at the greatest distance, and, consequently, the properest for a "bull's eye."

Every shot being marked, and pointed out to the man who fired it, he will always be able to form criteria, by which to regulate his next attempt. Men might as well be made to shoot at a bottle in the dark, as to practise without knowing where the bullet strikes, except when they may chance to hit the bull's eye! I will venture to assert, that five shots fired with care, comparison, and reflection, will produce more improvement than fifty expended in the usual irrational manner!

It is particularly requisite to attend to the *perpendicular* line; and that no shot be allowed to count, which strikes the butt at more than five feet from the ground. In service it is far better that the bullet should fall rather short, than that it should go over the adversary's head; as in the former case, if it be on tolerably level ground, and in the right *perpendicular* direction, there is a great probability of its hitting him by the ricochet.

Both in rifle and pistol-shooting an absurd custom prevails, of pointing the piece *upwards* and bringing it *down* to a level with the object to be fired at. Instead of this practice, to which there are many objections, the piece should previously to being cocked, be pointed *downwards*, at less than a yard from the foot of the firer. It is then to be steadily raised up in the line of the object, and when within a certain distance from the proposed level, the trigger (if not a detent) should be gradually pressed, according to the knowledge which the firer has of it, so that it may just go off, without any *pull*, at the desired moment. While the piece is in motion upwards,

the perpendicular line described will be true and steady, and the quicker the motion the truer the line. When the perpendicular motion ceases, the horizontal vacillation begins. The aim, therefore, should not be prolonged beyond the arrival of the sight at the intended level, but whenever it is so, the piece must be lowered below it, and brought up again.

After a certain period of practice, the men should be obliged to fire by signal, and with a limited aim. For example: the man, with his left foot foremost, erect, and looking steadfastly at the object, with the piece pointing to the ground, as above mentioned, the word is given to "cock." Then "one—two—three—four!" at the rate of a second's pendulum. The raising of the piece must commence at "one," and the shot be off at "four!" After some practice the numbers may be counted quicker, and only extended to "three!" By this method, the men will learn to shoot in the most efficacious manner; for the most accurate marksman will find his ability comparatively unavailing in real service, unless he can apply it in a quick and off-handed way. He will find that it is one thing to aim leisurely at a stationary iron target, and another to shoot at men in motion, who are briskly returning him the compliment!

By strict attention to the foregoing hints, any man endued with an average share of aptness and intelligence, ought, in favourable weather, after the proper progression of instruction for a month, to put, at least, three balls out of six into a target of two feet by five, at the distance of four hundred measured yards. He would, moreover, with my rifle cartridges, and the ramrod above described, load within less than twenty per cent. as fast as can be done with a common musket, which fired by the same hand at the same distance, would not hit a mark of twice the size one time in fifty!

Mr. Benjamin Robins, the celebrated author of "New Principles of Gunnery," concludes his tract on "Rifled-barrelled pieces," with the following remarks. "I shall therefore close this paper with predicting, that, whatever state shall thoroughly understand the nature and advantages of rifled-barrel pieces, and having facilitated and completed their construction, shall introduce into their armies their general use, with dexterity in the management of them; they will by this means acquire a superiority, which will almost equal any thing that has been done, at any time, by the particular excellence of any one kind of arms; and will, perhaps, fall but little short of the wonderful effects which histories relate to have been formerly produced by the first inventors of fire-arms."

N.B. If, when Mr. Robins wrote the above, he had known how to load the rifle with the same ease and rapidity as the common musket, by means of my rifle cartridges, and, moreover, to combine with it an auxiliary far more powerful and efficient than the bayonet, that is my infantry lance, he would have had far greater cause to anticipate the most important results.

Whenever the percussion principle shall be adopted in the army, as it certainly one day must, my plan of the lateral screw and prepared cap described above, is the only one that will perfectly answer. It is unavailing for the percussion powder in the cap to be water-proof, as the water, by reason of the attraction of surfaces, ascends between the cap and the nipple, and wets the powder in the latter. My preparation of tallow and rosin applied to the interior surface of the caps, entirely prevents this introduction of water, so that the gun will go off after being wet with rain for a week. According to the climate, more or less rosin must be added to the tallow. I find I can apply the composition to the caps with sufficient rapidity, by means of a little camel-hair pencil, or with a piece of hot iron wire a little less than the diameter of the caps. These water-tight caps must be larger than the unprepared ones, to allow for the space occupied by the composition. They must also be strong, so as not to open upon being pressed on to the nipple.

ACTIONS OF THE BRITISH CAVALRY.*

A SHORT time after the battle of Albuera, an affair occurred in which a squadron of the 3rd Dragoon Guards most gallantly charged, and drove out of the wood near that town, an infinitely superior force of the French cavalry. This squadron had been detached on duty along with some Spanish troops, who, on the commencement of the action, fled and deserted it after a feeble demonstration, rather tending to encourage, than intimidate the enemy. Captains Watts and Mannsell leading on their men with the utmost coolness and bravery, repulsed and overthrew their opponents with considerable loss. Capt. Watts himself was wounded, and a few men and a subaltern officer were killed. This partial combat was highly spoken of at the time by Sir Rowland Hill; but from some circumstances, connected, as was understood, with the misconduct and cowardly desertion of the Spaniards, no official notice was taken of it in any dispatch.

At the glorious and complete victory of Salamanca, it is well known how greatly the conduct of the cavalry contributed to the result. The Gazette account says, "Under Lieut.-Gen. Sir Stapleton Cotton, a most gallant charge was made against a body of the enemy's infantry, which they cut to pieces." But this is only a concise notice of the admirable manner in which that distinguished and able officer brought his troops into action, supporting Gen. Pakenham's corps until the impression had been made upon the French line, and then throwing his squadrons forward on the right, and outflanking and bearing down column after column of the infantry, as they vainly endeavoured to rally and recover their lost order. The 5th Dragoon Guards and 4th Dragoons were particularly distinguished upon this occasion, nor was any very heavy loss sustained by the victors, except in the death of Gen. Le Marchant, in whom the country was deprived of a "*noble officer*," to quote from the dispatch, in which a just tribute was paid to his merit by Lord Wellington. Salamanca, it may be observed, was one of the few occasions during the Peninsular War, where circumstances and opportunity allowed of any large united force of the British cavalry taking a prominent and conspicuous part in a general action; and both their leader and the troops under his command, acquitted themselves with no ordinary degree of credit and success, as has been fully allowed by the French officers, particularly by Marmont himself, who was never above praising an enemy, and who, however unfortunately his military career has terminated in the last revolution, must, both from science and experience, always stand high among the Marshals who earned their bloody laurels under Napoleon. After the retreat from Burgos, the first affair of cavalry was in 1813, at Morales, when Colonel (now Sir Colquhoun) Grant, at the head of the Hussar Brigade, himself leading the 10th, and followed and supported by the 15th and 18th Hussars, made a very judicious and well-timed attack on a considerable body of French cavalry, of the proximity of which he had received information, and had in consequence advanced in order to bring them to action. There could not be a more complete overthrow than the French cavalry received on this occasion from the British. They were driven back in utter disorder and confusion upon their infantry and

* Continued from page 363.

artillery, with the loss of a great number of killed and wounded, and above two hundred prisoners. At Vittoria, the nature of the ground did not admit of the cavalry being employed during the engagement, and until the battle of Orthez, there occurred no cavalry action of any consequence. In the official account of that battle, we find the following passage.

“The only opportunity which offered to charge was taken advantage of by Sir Stapleton Cotton with Lieut.-Gen. Lord E. Somerset's Brigade, in the neighbourhood of Sault de Navailles, where the enemy had been driven from the high road by Lieut.-Gen. Hill: the 7th Hussars distinguished themselves on this occasion, and made many prisoners.”

This attack of the 7th Hussars was, in its details, very deserving of the praise bestowed, for being made exactly at the opportune moment when the enemy had first been driven from their positions by the infantry, the confusion was increased to a degree only to be appreciated by those who have seen the extraordinary panic which falls upon broken infantry when the cavalry “*are among them,*” and the pursuers returned with almost double their number of prisoners, and with but little loss to themselves.

On the day before the battle of Thoulouse, the 18th Hussars in the advance fell in with and attacked two regiments of French cavalry, which affair was thus noticed in the Duke of Wellington's dispatch. “The 18th Hussars, under the immediate command of Colonel Vivian, had an opportunity of making a most gallant attack upon a superior body of the enemy's cavalry, which they drove through the village of Croix d'Orade and took about 100 prisoners, giving us possession of a most important bridge upon the river Ers, which it was necessary to pass in order to attack the enemy's position.” The details of this affair show beyond all question, that the success was not owing to mere courage and impetuosity, but that the steadiness and good order of the British cavalry were equally conspicuous. The leading squadron only of the 18th was the attacking force, the remainder of the regiment being withheld in reserve, at a considerable distance in the rear, so as to have allowed of the party which made the attack falling back and rallying behind the main body, had they been less successful, without any hazard of the latter being involved in the confusion. The disposition of the French, on the other hand, showed great want of caution and judgment, for they were formed in one united column upon the causeway beyond the bridge, so that the moment the charge of the leading squadron of the 18th had overthrown those immediately in front, the disorder spread to the rear of the whole column, which presently became an unmanageable and confused crowd, unable to effect any regular retreat, or make their escape on the flanks where they were confined and hemmed in by deep ditches, into which many of them were forced, with heavy loss to themselves and very little to the victors, of whom only a few private soldiers were killed, and Colonel Vivian and Capt. Croker wounded.

In the battle of Thoulouse there was little employment for the cavalry, and we proceed to close the account of their actions in the Peninsula, by noticing the inconsiderable but very gallant affair in which Major Bridger, with a squadron of the 12th Light Dragoons, having fallen in with a strong picket of French infantry, not only threw them into

complete disorder by his resolute charge, but contriving to prevent the escape of any of the detachment, marched the whole of them prisoners into the British lines.

Want of information has prevented the enumeration of many brilliant actions of the cavalry during the Peninsular war, a contest so full of great events, that in the dispatches no room could be afforded of recording any other than the principal features of what occurred. The record books of the 14th and other distinguished regiments, whenever their contents are investigated and published, will prove more than any assertions we could now make; but it is singular how very great difficulties the commanding officers have met with in the compilation of these records from the confused recollections of dates, the great changes which the lapse of years has caused in the ranks of the army, and the few officers and soldiers now in the cavalry who were actors in the glorious and bloody scenes of the Peninsula.

The battle of Waterloo, that memorable crisis which showed the astonished nations that Napoleon was not invincible, and that his great rival was destined at last to tear the laurels of a quarter of a century from his brow; that victory which in its results has had no parallel in history, and has raised the soldier of Great Britain, if any thing was wanting after the Peninsular war, to his proper station among the military of Europe, has been most invidiously quoted against our cavalry, but more especially the light dragoons, not from any general and fair inference, but principally on account of the reverse sustained on the 17th by the 7th Hussars. Every detail of that disaster of a regiment which had established a character of long standing in the army, must, if candidly examined, refute completely the unjust imputation under which they were condemned to suffer until the popular cry, or rather calumny, had subsided. The cavalry, it will be remembered, had on the 16th made a very long and fatiguing forced march from their cantonments to Quatre Bras, where they arrived very late, having many of them come above thirty-five miles since the morning. Early next day, 17th, the whole army commenced retreating upon the position of Waterloo, marching in two columns with the cavalry covering their rear. Those who retreated by the main road were severely pressed, and that squadron of the 7th Hussars which formed the actual rear-guard, was harassed by skirmishing and partial attacks during almost the whole of the day, without rest or intermission. The French cavalry in advance under Gen. Colbert, were admirably led by that distinguished officer, and pressed vigorously forward both in the street of Gemappe, and at the crossing of the bridge at the extremity of that village. This it is necessary to notice, because those who have served much against them, are well aware of the extraordinary effect produced on French troops, especially cavalry, by finding themselves in the situation of pursuers, no matter under what circumstances, or whether their opponents are retiring of their own accord, and for an ultimate object, or are reluctantly yielding the ground before them.

Soon after passing Gemappe, the infantry beginning to march into position, it became necessary to check the pursuit of the French cavalry, and the 7th Hussars were accordingly ordered to make front to their rear, and charge the head of Colbert's column. Confidence in his own distinguished regiment, of whose courage and conduct he had so frequently had every experience, unfortunately led Lord Anglesey to forget the discouraging and distressing duty on which the rear squadron

had been employed during the day, and not stopping to relieve them by fresher troops, he instantly commanded them to attack their pursuers. Now, he it observed, the scene of conflict was a deep road cut down through the rise of the hill, with very high and steep banks, and so utterly ruined and saturated with the rain which had fallen, that the horses were actually up to their knees in a wallow of mud, through which the fatigued and exhausted animals were driven to the attack, not of an ordinary column of cavalry but of a serried mass of lancers, so crowded upon from behind, that they knew they could not retreat, and instead of advancing to meet the 7th Hussars, contented themselves with stiffly setting their lances in the rest, as it were, and receiving the charge behind the formidable *chevaux-de-frise* they were thus enabled to present, and which might bid defiance to any but a most rapid as well as furious onset, such as the weary horses of the 7th were quite incapable of making through the sea of mud in which they were embarrassed. Major Hodge and Mr. Meyer, the adjutant, fell among the foremost in desperately attempting to break through the array of lances, and nearly half of the squadron met the same fate. The remainder, dispirited by the loss of their gallant leaders, and falling into irreparable confusion, were driven back, till the banks of the road becoming more accessible, as they retired, enabled them to rally and recover their order. Then it was that the first Life Guards, who had hitherto been unmolested in their march, fully conscious of their own valour and strength, and of the weight and power of their horses, having undergone no fatigue, and in eager spirits for combat with an enemy of whose vicinity they were made every moment more aware by the animating shouts behind them, which only stimulated their repressed ardour, received the long wished-for command to go threes about and charge the French column. Led by the brave Major Kelly, they went down, rear rank in front, upon their opponents, with a force and vigour which nothing could withstand. The lancers having lost their first array, in pursuit of the broken hussars, were no longer able to protect themselves as before, and that very solidity, arising from numbers crowded into small space, which had been of such advantage to them while they retained their formation, now only served to render them an easy prey to their almost gigantic adversaries, who rode over and forced them down the hill with overwhelming impetuosity. Three times they attempted to rally, and as often were they charged with equal success by the Life Guards, who thus effectually secured the retreat of the army into its position, and terminated the fighting for that day upon the main road. On the other road, the enemy brought some artillery more than once into action against the cavalry which formed the rear guard, but no serious interruption of the retreat on that line of march was attempted.

In the great battle of the 18th, the principal operations on the part of the cavalry may be divided into three periods.

The charges of the Household Troops and King's Dragoon Guards against the columns of cuirassiers who attacked the position on the right of the road.

The charge of Sir W. Ponsonby's brigade, the Royal Greys, and Enniskillens, upon Count Erlon's columns, with the attack of the column of infantry of Gen. Durutte, made with such success by Colonel Frederick Ponsonby at the head of the 12th Light Dragoons.

The movement of the two brigades of cavalry from the left of the

position towards the close of the day, and the charge of these troops upon the retreating columns of the French army.

Besides these marked features of the battle as regards the cavalry, there were constant charges and attacks on the right of the line, in which Sir C. Grant's brigade of light cavalry, comprising the remains of the 7th Hussars, obtained much well-merited distinction, not only by their boldness in advancing, but by their steadiness when exposed to an unceasing and most tremendous fire of musketry and artillery, than which no severer test can be applied to the order and bravery of the dragoon.

As regards the details of the three periods, or leading features, to which we have alluded, we may first observe that the desperate and furious attacks of the French cuirassiers, which were so steadily received by our infantry, and so effectually returned by the Household Brigade under Lord E. Somerset, were neither well judged nor well timed on their part, and only served to annihilate and destroy a magnificent corps, which deserved a better fate. So much was this felt even by their own leaders, that Gen. L'Heritier, a very distinguished officer, who commanded a brigade of these gallant cuirassiers, in reply to a question from an English officer after the peace, as to the cause of their charging so early in the day, and with so little regard to opportunity, gave it as the real reason, that they had been placed in a position so exposed, and had been so dreadfully galled by the fire of our infantry and guns, that the impetuosity of the French character would no longer be restrained within bounds, especially as the suddenness of their reorganization after Napoleon's return had of necessity somewhat deranged their discipline; and there arose such a dangerous clamour in the ranks, and such earnest demands to be led forward, and in their own words, to have "*vie pour vie*," that the officers were compelled to lay aside their better discretion, and at once bring them into action at all hazards. To have resisted successfully the onset of these desperate veterans reflects immortal glory on the British infantry, but to have overthrown and pursued the cuirassiers of France back into their own lines, is no less honourable to our Household Brigade. If any proof could be wanting of the extraordinary bravery of the cuirassiers, it may be found in the well-known fact, that in some parts of the line, where there were no disposable cavalry to pursue them when retiring from their attacks of our infantry, and where the artillery supplied this want by playing furiously upon them during their retreat, whole regiments actually went off at a deliberate walk, nor did the slaughter produced by the well-directed fire of the guns, induce them to quicken their pace or desist from this murderous bravado.

Certainly it could be no very ordinary cavalry who were able to make any impression upon such men as these, who had almost to a man seen many years of active service, and who were mounted upon that excellent description of heavy cavalry horse which is in use with the *gendarmerie*, who were just before dismounted by Napoleon's order, for the express purpose of giving good horses to the cuirassiers.

The second important occurrence in this battle, as regards the cavalry, was the attack of Sir William Ponsonby's brigade, made under the direction of Lord Anglesey. The Duke of Wellington's dispatch mentions this with due praise, but the public in general have been little aware how very great an effect it produced, or what important results arose from its success. From Napoleon himself there is not a

French military author who has spoken of Waterloo, that has not borne testimony to this fact. His exclamation on seeing the Greys among the French Reserves is well known, "*Voici encore ces terribles chevaux gris!*" a memorable tribute of honour to that distinguished regiment, which ought to be emblazoned on their standards, as the most brilliant motto which could ever be devised.

At the moment when Sir W. Ponsonby's brigade went into action, the French were advancing in three heavy columns of about 5000 men each; that on the left was severely handled, and eventually checked by the tremendous fire of Sir J. Kempt's brigade: the advance of the two other columns had been opposed by the light infantry of the remainder of Sir T. Picton's division, who, however, were falling back before them upon the main body of that division, which was stationed upon the crest of the position, awaiting the French columns. Scarcely had these last reached the hedge, which ran along the brow of the hill in front of the British line, when they were received by a destructive fire of musketry, and while shaken by its effects, the Royals, Greys, and Enniskillens, who had been concealed behind the infantry, advanced by threes from the flanks of squadrons, and passing through the openings made for them in Sir T. Picton's division, rapidly formed their line, and dashing through the hedge, rushed upon the head of the French columns. Their charge was too sudden, too unexpected, and too vigorous, to be withstood; a straggling fire was attempted by the leading companies, but confusion spread through their ranks; they were overborne by the cavalry, and in an instant the field was covered far and wide with dispersed and terrified fugitives.

Almost at the same moment, that admirable officer, Colonel F. Ponsonby, who was posted further to the left at the head of his fine regiment, the 12th Light Dragoons, perceiving an unsteadiness in the advance of Durutte's column of near 4000 men, seized the opportunity with that quickness of eye and ready judgment for which he was always remarkable, and by a desperate charge threw them into as great disorder as the others, and drove them back upon their reserves.

Such was the fate of the French attack; the whole of these columns being overthrown, with immense loss in killed and wounded, besides nearly a thousand prisoners. Unfortunately the ardour of pursuit led the victorious squadrons too far, and although they actually took one of the reserve batteries, cutting down the artillery men at their guns, yet from this very circumstance, they lost their own order, and the remainder of Sir J. Vandeleur's brigade being too much occupied by the demonstrations of the enemy to come forward in support, the French quickly assembled a heavy column of lancers and cuirassiers, and falling upon the flank of Sir W. Ponsonby's brigade before their officers could effect a rally, repulsed them, with the loss of their gallant leader, the 12th Light Dragoons also leaving their Colonel for dead upon the field. Certainly their success was dearly purchased, but if ever the attack of cavalry produced decisive effects upon the result of a general action, such was the case upon this occasion.

In the French official account we find this part of the battle thus noticed:—

"Le deuxième brigade (of Count Erlon's corps) fut chargé par un corps de cavalerie Anglaise qui lui occasiona de grandes pertes. Au même moment une *division* de cavalerie Anglaise charge la batterie du Comte Erlon par la droite, et lui désorganiza plusieurs pièces, mais enfin les cuirassiers de

Milhaud chargèrent cette division dont trois régimens furent rompus et sabrés."

Now these "*trois régimens*" were in reality like the two buckram men of Falstaff who became eleven, the whole of the cavalry in question, with the addition of the 12th Light Dragoons. The French account, it seems, could not deny the tremendous effect of the cavalry attack upon their columns, but attributed it, to save their credit, to about three or four times the actual force engaged upon this point of the position.

Gen. Müffling, with more candour, says—

"Sir W. Ponsonby and Gen. Vandeleur rushing forward, drove the enemy's cavalry over the adjacent hollow, sabred great numbers of their infantry, wounded many more, and took about 1000 prisoners."

The "*Victoires et Conquêtes*," a work in which the French have certainly not under-rated any of their military feats, narrates the same attack as follows:—

"Profitant du moment favorable la brigade de cavalerie (dragons Anglais) commandé par le General Sir W. Ponsonby, placée en reserve derrière cette partie de la ligne ennemie, entama une charge à fond sur la colonne Française, la rompit, lui enleva deux aigles, et lui désorganisa sept pièces de canon."

The "*Victoires et Conquêtes*" then proceeds to state with what destructive effect Gen. Travers, with a brigade of cuirassiers and the 4th Regiment of Lancers, avenged the ill fortune of their comrades of the infantry; but this does not in any degree weaken the admission already made in favour of this splendid attack of the British cavalry.

Gen. Gourgaud, speaking of the same crisis, tells us that the cavalry made a successful charge on one of the columns of the first corps, and on a battery of fifteen pieces of cannon, driving them all back upon the hollow road, but Milhaud sending a brigade of cuirassiers upon their flank, *the field was soon covered with slain*,—thus carefully evading to declare who were the victors in this general carnage.

We shall now advert to the third period in the battle, at which the services of the cavalry appear to have been of great effect. Those who felt the blow are probably the best evidences that can be adduced, and we accordingly again turn to the French official account—

"At the end of the day, a charge directed against the flank of four battalions of the *Moyenne Garde*, by several English squadrons, threw them into disorder; the fugitives recrossed the Ravine, cries were raised of '*Tout est perdu! la Garde est en déroute*,' &c. &c.

And then comes the description of the irremediable rout and defeat of the whole army of Napoleon.

The *Victoires et Conquêtes* take the same view of this part of the action—

"La nuit commençait; une charge de quelques escadrons ennemis les met en désordre (the guards); ils fuient, et entraînent avec eux d'autres régimens, qui, voyant reculer les troupes de la Garde, pensent que c'est la *Vieille Garde*, et s'ébranlent; le mouvement se communique aussitôt aux régimens voisins, '*Tout est perdu*,' s'écrite-t'on, la Garde est repoussée; sauve qui peut."

Gen. Gourgaud concurs with the above, but places the conduct of these brigades of cavalry in a still stronger light.

“ The sun had set, there was no reason for despair, when the two brigades of the enemy’s cavalry which had not yet been engaged, penetrated between la Haye Sainte, and Gen. Reille’s corps; they might have been stopped by the squares of the Guard, but perceiving the disorder, which prevailed on our right, they turned them. These *three thousand* fresh cavalry rendered all attempt at rallying impossible. The Emperor ordered his four squadrons *de service* to charge them, but these squadrons were not sufficiently numerous, the whole division of reserve cavalry of the Guard would have been necessary; the four squadrons were overwhelmed, and the confusion every moment increased.”

This charge of the *escadrons de service* fell upon the right of the 10th Hussars, and was not repulsed without severe loss by the right squadron of that regiment. Thus terminated the final effort of the French: and Gen. Müffling, after noticing this movement from the left by the two brigades of fresh cavalry, goes on to say,

“ The English army now advanced in lines as at a field-day, the cavalry attacks followed in rapid succession; the four battalions of the guard were like the rest dissolved, and the whole French army exhibited nothing but one great mass of all arms intermingled in the wildest confusion.”

In going through the principal actions of our cavalry, during the late war, at the conclusion of which we are now arrived, let it not be supposed that the subject has been treated with all the attention which it merited. We have been able to attempt nothing beyond a hasty sketch of the leading evidence upon which we feel fully able to refute Colonel Napier’s proposition, that the British cavalry are of a decidedly inferior class to that of the French. That the latter had brilliant successes when opposed to the half-disciplined armies of the Spaniards, far be it from us to deny; but were their successes equally decided and brilliant when opposed to the British? and if the latter were sometimes misled by their impetuosity, have we not convicted the French on more than one occasion of even greater want of discretion in their attacks? The nature of the Spanish war was such, that no instance occurred of great bodies of French and English cavalry coming into fair contact and being thus proved against each other; but whenever they did meet in small numbers, the advantage did not remain with the enemy. No cavalry, be it remembered, ever took the field with so little experience of service as ours at the commencement of the Peninsular campaigns, while, on the other hand, the French ranks were filled with veterans, who had served in all parts of the world, under experienced officers, in the constant habit of manœuvring and commanding cavalry in large masses, and with almost unvaried success.

Some advantage may also fairly be given to the French in the simplicity and practical merits of their system of forming and disciplining their cavalry, a simplicity of more consequence than can be imagined in the field, where confusion is always the principal danger of cavalry. An opinion is said to have been given by the greatest military man of this or perhaps any other age, that, although a single regiment of British cavalry would at any time overthrow a similar force of the French, yet that the latter possessed so much greater facility of manœuvre, combined with steadiness and order, that, should the experiment be tried with larger numbers, the French would have the superiority in proportion as the numerical force was increased on both sides. It has been said, by some bold men, that the celebrated person alluded to, is not well versed in the tactics of cavalry. It would be

about as reasonable to attempt proving to a carpenter, that he is no judge of the excellence or defects of the tools with which he performs his work. It is some elucidation of this subject to observe, that the Prussian cavalry for some years after the beginning of their war with France, were trained upon the system of Von Saldern, of which Dundas was merely the literal translation, but so convinced were the Prussians of the superiority of the French cavalry tactics, after being opposed to them during the few first campaigns, that not disdaining to profit by the enemy's lessons, they laid aside the complicated manœuvres of Von Saldern, and adopted a system grounded upon that of the French, but still farther simplified in its details. To obtain what are called *good fighting lines* quickly, and to advance and retire with steadiness, and without losing that compactness which is the chief essential of cavalry, must always be the main object. For the purpose of all formations, the less officers are shifting and moving from one flank to another, the less is the chance of error and confusion, a point overlooked in Dundas, or rather Saldern, who sacrificed practical advantage in this case to minute detail and useless preparation, so that not only was there a great deal of shifting about of officers and detaching of numerous markers before any formation could take place, but the time wasted in these operations and in preparatory movements was obliged to be regained by such rapidity and galloping in the actual execution, that the difficulty of preserving order, and accomplishing steady and correct formation of line, was very materially enhanced. The subject of the cavalry manœuvres has been above two years under consideration of the Authorities, and a Board is now sitting with a view to examine the subject. The President, an officer of excellent judgment and great experience in the field, has been deservedly raised to the highest honours for his services in the Peninsula. He is assisted by general officers of well-earned celebrity, and the inferior members have been distinguished at various times and in their respective ranks in many of the scenes we have endeavoured to record. The duty now imposed upon them is most important, and as it could not be entrusted to better hands, there is every likelihood of the cavalry obtaining the great advantage of a system of sound and practical movement, well adapted to the purposes of the field abroad.

But to conclude, let us beg to be understood that we do not pretend to arrogate for the cavalry the same absolute superiority over all the rest of Europe, which has been so justly claimed by Colonel Napier for the infantry of Great Britain. The infinitely greater experience which the French cavalry obtained during the wars of the Revolution, have certainly raised them to a greater celebrity than even their infantry. All we assert is the mere fact, that when the British and French cavalry have fairly met, the former have been generally found victorious in spite of many disadvantages, and that Colonel Napier's distinction is neither fair nor supported by evidence, when he so decidedly allots them the *second* place as regards the cavalry of France—"Non jam prima peto," but we cannot submit to a direct acknowledgment of inferiority. We have rested our arguments upon plain facts, and above all, upon the admissions of our rivals, and we leave it to the candid reader to judge whether we have redeemed our pledge.

VINDEX.

THE SERVICES OF THE LATE
CAPT. SIR MURRAY MAXWELL, KNT. AND C.B.

THE late Sir Murray Maxwell was of an ancient Scottish family. His father, James, who sent seven of his children into the Army and Navy, was son of Sir Alexander Maxwell, Bart. of Monreith, and of Lady Jane Montgomery, daughter of the Earl of Eglinton, and uncle to Jane, who married Alexander fourth Duke of Gordon.

Sir Murray first went to sea with his friend and patron Sir Samuel Hood, in the *Juno*, and was in that ship when Sir Samuel ran into Toulon in search of Lord Hood's fleet, and found himself aground, and surrounded by the revolutionary one, who endeavoured to take possession of him. The miraculous escape of the *Juno* is matter of history. Whilst belonging to this ship, he was employed in the batteries ashore, at the taking of Corsica, and reduction of Bastia. We now trace him acting Lieutenant in the *Nemesis*, when she was taken by a very superior French force in the Gulph of Smyrna; and afterwards second Lieutenant of the Hussar frigate, when she was wrecked on the coast of France, where he remained a considerable time prisoner of war.

Having been liberated by exchange, he was made a Lieutenant 10th October 1796; and in December 1802, was promoted to command the *Cyane* sloop, in which vessel he gave early proof of the promptitude and decision which so marked his after-life, by the detention, on his own responsibility, of two French transports filled with troops, destined to reinforce their West India possessions, and which had departed from France on the immediate breaking out of the war; the news of which had not reached the station he was on. Whilst cruising in the same ship, off Port Royal, he also engaged and beat off two French frigates, endeavouring to get into Martinique. In the following June, he was, with the *Cyane*, at the reduction of St. Lucia by the ships under the orders of his patron. After this affair he was removed into the *Centaur*, 74, on board of which ship Commodore Hood had his broad pendant; was present when Tobago, Demerara, and Essequibo, were taken in July and September 1803; and on the 4th August in the same year, his commission as Captain was confirmed, and he was subsequently at the blockade of Martinique, on which occasion his ability was displayed in fortifying the Diamond Rock, and placing on its summit two 18-pounders, hove up from the ship by means of hawsers; this feat was reckoned so extraordinary as to become the subject of a series of engravings at the time, which we have seen.

In April 1804, an expedition under the orders of Commodore Hood and Major-Gen. Sir Charles Green, was undertaken against Surinam. On the 25th April, the *Centaur*, the Commodore's ship, anchored about ten miles off the Surinam river, and on the following day a landing of a division of the army was effected. Capt. Maxwell and an aide-de-camp of the Major-General's, were sent with a summons to the Dutch Governor to surrender, which, on the 28th, he answered with a refusal. After many brilliant exploits, the Governor offered terms of capitulation, and on the 5th of May, the fort of New Amsterdam was taken possession of by an advanced corps under the orders of Brigadier Maitland. This important affair having thus terminated, Capt. Maxwell was sent home with the dispatches; and he afterwards returned

to the West Indies, and commanded the *Centaur* when the Commodore had struck his pendant. From this ship Capt. Maxwell removed into the *Galatea*, and was subsequently appointed to the *Alceste* of 46, formerly *L'Universe*.

In April 1808, Capt. Maxwell was cruising off Cadiz, with the *Mercury* and *Grasshopper* under his orders, when a fleet of Spanish vessels were discovered under the protection of twenty gun-boats and a train of flying artillery. Off Rota, Capt. Maxwell commenced a vigorous attack, when two of the gun-boats were destroyed, several of the merchant vessels driven on shore, and some captured by the boats of the frigates.

After this brilliant service, the *Alceste* was employed on the coast of Italy, where Capt. Maxwell assisted at the destruction of various armed vessels and Martello towers. On the 22nd May 1810, a party from Capt. Maxwell's ship stormed a battery near Frejus of two 24-pounders, spiked the guns, and blew up the magazine; and a few days afterwards her boats attacked a French convoy, captured four vessels, drove some on shore, and compelled the remainder to put back.

Towards the close of the year, Capt. Maxwell was attached to the in-shore squadron off Toulon; and in the following year was under the orders of the late Sir James Brisbane on the coast of Istria, where he assisted at the destruction of a French brig in the harbour of Parenza.

In November 1811, Capt. Maxwell, with the *Active* and *Unité* under his orders, fought a most gallant and brilliant action in the Adriatic, with three large French frigates. His little squadron was lying in the harbour of Lissa, (which island he had fortified,) when the enemy were signalized, and notwithstanding the difficulty occasioned by a strong gale blowing directly into the harbour, he succeeded in warping out the three vessels under his orders. After a warm conflict of two hours and twenty minutes, the *Unité* succeeded in capturing *la Persanne*, a French store-ship, of twenty-six 9-pounders and 190 men, and having in her hold 120 guns, and several pieces of brass ordnance. The *Alceste* commenced action with the other two, but unfortunately having the main-top-mast shot away, dropped astern, when the *Active* pushed up, and brought the sternmost to action within pistol-shot. The French Commodore, from the disabled state of Capt. Maxwell's ship, made off to the westward; the other having been totally dismasted surrendered, when it was found she had five feet water in the hold, and proved to be *La Pomone*, of 44 guns and 322 men. In this brilliant action the *Alceste* had twenty killed and wounded, and the *Active* thirty-five, her Captain (Gordon) having lost his leg. The Captain of the *Pomone* surrendered his sword to Capt. Maxwell as the Commodore, but the latter, with equal delicacy and magnanimity, immediately presented it to Capt. Gordon.

Capt. Maxwell's next appointment was to the *Dædalus*, which ship was unfortunately wrecked, 2nd July 1813, on a shoal near Ceylon, while conveying some Indiamen to Madras.

In 1815, an embassy to China was determined on, and Capt. Maxwell was appointed to the *Alceste*, which was to convey Lord Amherst.

The *Alceste* sailed from Spithead 9th February 1816. The details of the voyage to China, the visit to the Loo Choo Islands, with the aid afforded to science by her discoveries in the Yellow Sea and

coast of the Corea, the subsequent loss of the *Alceste* on the 18th February 1817, by striking on a sunken rock, about three miles from Pulo Leat, in the Straits of Gaspar; the sufferings of the Ambassador, officers, and crew, have been so fully detailed by Capt. Basil Hall, who commanded the *Lyra* sloop, the consort of the *Alceste*, and which that scientific and excellent officer dedicated to Capt. Maxwell, as to render a repetition unnecessary. Mr. M'Leod, the Surgeon of the *Alceste*, also published a most interesting narrative of the circumstances. The lustre of Capt. Maxwell's character received even an additional brilliancy from this misfortune; for, to adopt the language of the Court Martial by which he was subsequently tried, "his coolness, self-collectedness, and exertions were highly conspicuous, and everything was done by him and his officers within the power of man to execute."

The Chinese will never forget the chastisement they received when the *Alceste* forced through the *Bocca Tigris*, or Canton river, to receive Lord Amherst on his return from Pekin. The officers and crew were all animated with a similar feeling to that of their heroic Captain, and it is said that on one of the quarter-deck 32-pound shot, some of the young gentlemen had written in chalk, "Tribute from the King of England to the Chinese," and which was actually fired against their flotilla of eighteen war junks, after which their batteries were silenced by a broadside. Captain Maxwell fired the first gun, thus rendering himself personally amenable to the consequences of the attack, as it is well known that the Chinese attach responsibility to the individual whose hand was immediately employed in the discharge.

On the 12th April, the Ambassador, Capt. Maxwell, and the officers and crew of the late *Alceste*, sailed from Batavia Roads in the *Cæsar*, a ship hired for that purpose. At St. Helena, Capt. Maxwell had an interview with Buonaparte, who remembered he had commanded the *Alceste* at the time *La Pomone* was taken in the Adriatic, when he said to Capt. M. "*Vous êtes très méchant. Eh bien! Your Government must not blame you for the loss of the Alceste, for you have taken one of my frigates.*"

The superstition among seamen for particular days is well known. When the information of the loss of the *Alceste* was received at Portsmouth, very few expressed surprise, and they said, "We were sure it would happen, for she sailed from Spithead upon a Friday!"

In June 1815, the Order of the Bath was formed into three classes, and Capt. Maxwell was nominated a Companion of the same; and on the 27th May 1818, he was honoured with Knighthood.

A general election occurring this year (1818) Sir Murray Maxwell stood a candidate for Westminster, where, although polling above 4800 votes, he was unsuccessful. During the contest, which was of unexampled violence, he showed such temper, coolness, and good-humour, as greatly to disarm the fury of the mob, who sided with his opponent, until a ruffianly attack upon his life prevented his further appearance on the hustings. The pecuniary losses he sustained on this occasion were so great, that we regret to learn his affairs never subsequently recovered from them.

The East India Company, taking into consideration the services of Sir Murray Maxwell in the voyage to China, and the great losses he had sustained on that occasion, presented him, in May 1819, with 1500*l.*

Vice-Admiral Sir Benjamin Hallowell (now Carew) being nomi-

nated, in June 1821, Commander-in-Chief at the Nore, Sir Murray Maxwell was appointed Captain of the *Bulwark*, the flag-ship; and on the 28th November the following year, removed from thence to the *Briton* frigate, in which he sailed to South America, where he was present at the surrender of Callao, and was employed in the protection of the British interests at that and other places on the coast.

The following is a literal translation of an extract of a letter to Sir Murray Maxwell, by Gen. Rodil, who so gallantly defended the fortress of Callao on that occasion.

"I, with the individuals defenders of Callao, who owe to you, Sir, so many favours, and in short our existence, cordially salute you. We will relate the estimation which you merit from us, the benefits you conferred upon us in that unhappy country, and likewise during our voyage.

"We pray Heaven you may everywhere meet with friends equally sensible of those superior virtues and heroic proceeding displayed towards the unfortunate which reflect on you so much credit."

The period for which the *Briton* was attached to the ships on that station having expired, Sir Murray Maxwell returned home, and was paid off.

Soon after the accession of his present Majesty to the throne, he was pleased to nominate a certain number of officers to be his naval Aide-de-camps, and Sir Murray Maxwell had the honour to be selected as one of them; and during the present year was appointed Governor of Prince Edward's Island, but which he was destined never to assume. In June he left Scotland in a sailing-vessel for London, to make the necessary arrangements for his departure for America; during the passage he was seized with fever, with no means of bleeding him, and no surgical assistance to be procured till he arrived off Gravesend, forty-eight hours after the fatal attack, and shortly after arriving at Green's Hotel, Searle-street, Lincoln's Inn Fields, expired on the 19th of that month.

Of Sir Murray Maxwell's other brothers, Capt. Keith Maxwell, since dead, commanded the *Hound* sloop, at the commencement of the war, when by vigilance in overhauling vessels and boats of all denominations, as they passed Deptford, many valuable and efficient hands were procured for the naval service, and for which he obtained his Post Rank. He distinguished himself on the coast of France, whilst belonging to Com. Owen's squadron; he afterwards commanded the *Nymph* frigate in the North Sea, and formed one of the expedition to the Scheldt; but he had previously signalled himself by performing one of the most daring acts that grace our Naval Annals, by the cutting out of the *Cheverette* from Cameret Bay in July 1801. The details of this exploit are to be found in James's Naval History, page 214, vol. iii. Capt. John Maxwell died in May 1826, while commanding the *Aurora* frigate; Major Stuart Maxwell commanded a Brigade of Artillery during three campaigns under his Grace the Duke of Wellington in the Peninsula, and was presented with medals for Orthes, Nivelles, and Vittoria, and was also a Companion of the Bath. Lieut.-Colonel Archibald Montgomery Maxwell, unattached, from the Royal Artillery, is the only surviving brother.

Sir Murray Maxwell has left a widow and family, one of whom is a Commander in the Royal Navy.

PLAN OF ILLUMINATING THE SEMAPHORE TELEGRAPH.
BY LIEUT. ROBERT WALL, R.N.

To be enabled to communicate by Telegraph at night has long been considered a desideratum, and many plans have been suggested at various times for that purpose, but hitherto without effect.

The principal difficulty of signaling at night, with lanterns of any description, is caused by the general radiation of light from them, and at any distance the consequent confusion of appearance.

Having discovered a mode of illuminating the Semaphore wherein the foregoing objection was obviated, I wrote to my Lords Commissioners of the Admiralty in the year 1823, informing them of the circumstance, when their Lordships commanded me "to state the particulars of my plan," which, in their answer to my letter, their Lordships were pleased to term "*ingenious in theory.*"

The particulars of the plan are as follows:—There are three powerful lanterns, one of which is placed at the foot of the mast, and one opposite to each of the pivots on which the arms revolve; and they are so contrived, that the light from each is concentrated and thrown powerfully along each arm and the mast by their respective lanterns, but the lights are concealed, so the Telegraph is in fact illuminated by reflection; and the entire of the light from each lantern being strictly confined to its particular direction, the confusion of appearance attendant on general radiation is avoided. I will now show how all this is effected. The pivots on which the arms revolve are tubes, of about two inches in diameter, and being attached to the arm, of course are carried round with it in its vertical revolution. On the end of this tube, (which projects about two and a half feet from the mast,) is fitted a lantern, furnished with a powerful lens and a strong reflector: the two lamps for each arm, (it being necessary to illuminate the Semaphore at both sides,) are connected by means of a small tube, which is passed through the larger one that supports the arm, and each end of the small tube protruding through the side of the lantern, is retained in its place by the *up and down* turn-stays which are bolted to the mast. To understand this part, it will be necessary to consult the annexed drawing.

Fig. 1.

Fig. 2.

Fig. 3.

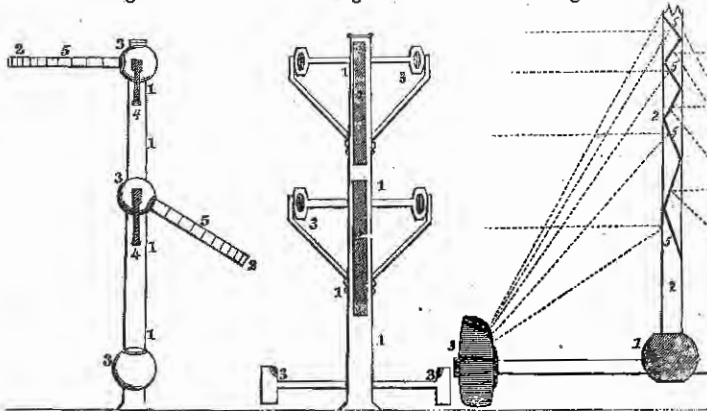

536 LIEUT. RAPER'S METHOD OF WORKING A DAY'S WORK.

Figure 1, Semaphore as seen by the observer; 1 1 1 1, mast; 2 2, arms; 3 3 3, lanterns; 4 4, stays for supporting the lamp; 5 5, reflectors.

Figure 2, shows the *side* of the Telegraph; 2 2, the arms; 3 3 3, the lanterns; 1 1 1 1, the mast. N.B. The reflectors at this view cannot be seen.

Figure 3, shows a *plan* of the mast, tube, lantern, arm, and reflectors—four times the size of the others.

In order that the *principal* rays of light shall be reflected to the observer, the surface of the arms and mast of the Semaphore is composed of small jalousie work, kept brightly whitewashed, which small reflectors are set at such angles *as shall reflect the rays of light incident to them, at right angles to the plane of the Telegraph*: so that in this plan we see that the arms, and the lanterns which are attached to them, revolve round the lamps which are stationary, but the light from thence is condensed, and thrown along the arms, in whatever position they may be in.

In the event of a war, to be enabled to hold Telegraphic communication at night would be just as necessary as in the day, manifestly, and in one sense of the word more so, at least in the winter; the high lands on which the Semaphores are placed being obscured by fog and mist, sometimes for a week together in the day, whereas the nights are for the most part clear and frosty, and therefore peculiarly well adapted to the observation of night signals.

Nor would it be at all difficult to fit a Semaphore to the top-gallant mast-head, which could be used either in the day or night. In short, I have a plan in process for that purpose, which will be shortly completed.

REMARKS ON LIEUT. RAPER'S METHOD OF WORKING A DAY'S WORK.

In the "United Service Journal" for January, a method is proposed by Lieut. Henry Raper, R.N. for working a day's work, by correcting the resulting course only, for variation, instead of each separate course.

As any method proposed by Lieut. Raper is likely to attract attention from his known attainments, and the operation itself is of importance from its frequent occurrence, the following brief observations may not be misplaced in the U. S. Journal.

Using the same figure, and making the same suppositions as Lieut. R., we have in the triangles CAB, *Cab*, the two sides CA, AB respectively equal to the two *Ca, ab*, and the angles contained by those sides equal; but since the curvature of CA is different from that of *Ca*, and the curvature of AB different from that of *ab*, it does not follow that the angle ACB is equal to *aCb*; the proof, therefore, which depends upon this circumstance, fails. The method, however, may be sufficiently accurate for practice, and seems to hold a like relation to the true method, that middle latitude does to Mercator's.

Portsmouth, July 20, 1831.

B.

REVIEWS AND CRITICAL NOTICES.

LIFE OF SIR THOMAS LAWRENCE.—Though unavoidably late in our notice of this work, we must still do justice, however briefly, to its interest and value. A more amiable or gifted individual than the subject of these volumes has not appeared upon the theatre of British art. Endowed with talents of the highest order, and recommended by the most engaging qualities of person and manner, Sir Thomas Lawrence represented the aristocracy of his beautiful art just as John Kemble portrayed that of the drama;—for even art and science have their contrasts and extremes of representation, allowing an equal sum of talent to the antagonist parties. Witness the familiar instances of John Kemble and of Kean, in the Drama—of Lawrence and of David, the Frenchman, in Painting—of Scott and of Crabbe, in Poetry.

The Biography of Sir Thomas Lawrence contains a great mass of original documents, and is creditable to the industry and ability of its compiler—Mr. D. E. Williams.

BROOKE'S TRAVELS IN SPAIN AND MOROCCO.—Spain, so familiar to British soldiers, is still a region of discovery to the British traveller; while the land of the Moors, the former Lords of the Alhambra, offers an excursion of congenial interest to him who visits the scenes of their triumphs and reverses on the opposite shore of the Straits.

The late Travels of Sir Arthur Brooke, of the date of which we have no other guide than inference, through these countries, are recorded in a remarkably agreeable and intelligent style;—undistinguished by any marked novelty, his descriptions are still replete with interest, lively, and characteristic, the language being that of an educated gentleman. A detailed description of Gibraltar and its celebrated siege, is included in these volumes, which are adorned by well-executed sketches.

LIFE AND ADVENTURES OF NATHANIEL PEARCE.—Nathaniel Pearce, a mixture of Giovanni, Finati, and Richard Lander, partly relates his own story, which is completed by means of other authentic documents, compiled and edited by Mr. T. J. Halls. The work is dedicated to the Earl of Mountnorris, who, as Lord Valentia, had accidentally fallen in with Pearce in his travels, and
U. S. JOURN. No. 33. AUGUST 1831.

had generously befriended that wild wayfarer.

Having eloped from home and gone to sea, Pearce passed through innumerable scenes and adventures, by sea and land, turning Mussulman at Mocha, rescued again from the wretched condition of a renegade by Lord Valentia, and finally accompanying Mr. Salt in his expedition to Abyssinia, where Pearce remained domesticated, at the departure of Mr. Salt, in accordance with his own wishes, as well as to further the objects of the mission.

The narrative abounds in adventure and descriptive details of Abyssinia and the various countries visited by Pearce. The latter, having returned in 1819 to Cairo, when he became confidential superintendent of Mr. Salt's household, closed his eventful career at Alexandria in June of the following year, at the moment of embarking to revisit his native country.

FLETCHER'S HISTORY OF POLAND.—This volume, hastily got up for the occasion, is nevertheless a seasonable compilation—as far as historical facts are valuable; though it is necessary in the sketch before us, as in many others of the day, to disencumber them of that load of declamatory clap-trap which invests certain characters, countries, and transactions, with preternatural purity, while it heaps upon others a sameness of obloquy equally undeserved. For many of the details respecting the Siege of Vienna and its deliverance by Sobieski, the compiler, we suspect, has been indebted to the interesting account published in this Journal, though his obligations are not acknowledged. The map, prefixed to the History, is a useful accessory to this volume, which is otherwise respectably executed.

CLASSICAL LIBRARY.—Volumes 18 and 19 of this useful series contain Translations of Horace and Phædrus—Juvenal and Persius respectively. The versions of the above authors are judiciously chosen, and the volumes are as well executed as their predecessors.

Numbers 2 and 3 of the **EPITOME OF ENGLISH LITERATURE**, containing the compressed works of Paley and Locke, are worthy of the same Editor—Mr. Valpy.

THE CABINET CYCLOPEDIA—AND LIBRARY.—A Treatise on OPTICS, forming the 19th Volume of the former series,
2 N

could not have proceeded from more competent hands than those of Dr. Brewster. The subject is, as might be expected, ably treated, and clearly illustrated.

The 20th volume comprises a HISTORY OF POLAND—a work of original research, ability, and impartiality. In consequence of its latter quality, it has, of course, been outrageously abused by the "Liberal" Press, the most despotic and partial of critics. That any writer should have had the audacity to ascribe other than the most monstrous attributes and motives to a Monarch and a Nation (the Russians) anathematized by its own Bulls, was an offence against the fourth estate not to be tolerated. A yell of liberal intimidation has, therefore, been opened by the whole pack upon the writer and editor of this devoted history, which, nevertheless, we venture to recommend as the most complete and faithful authority on the subject of which it treats, in our language. The explanatory Preface by the writer, penned evidently in deprecation of the anticipated storm, is sensible, candid, and convincing to all but—Liberals.

Of the Cabinet Library, vol. 5th con-

cludes the LIFE AND REIGN OF GEORGE THE FOURTH—a most useful compendium;—and vol. 6th forms the first of the MEMOIRS OF THE HOUSE OF BOURBON, of which work we shall be better able to form a judgment, when completed to our times.

THE SUNDAY LIBRARY, in Numbers 3 and 4, continues its series of select Sermons from the most eminent English Divines, with judgment and probable good effects. The collection is not to extend beyond six volumes.

THE SPORTING MAGAZINE, Numbers 2 and 3.—We were sportsmen in our "hot youth," and are so still at heart, spite of the gravity of our critical calling. Our recreations have fallen into the "sere and yellow leaf," and we greet the verdant cover of the Sporting Maga, as a type of our spring-time and its own hopefulness. We trust it may grow to an equally green old age.

Notices of many publications are unavoidably deferred,—amongst them are Sir Edward Seaward's Narrative, edited by Miss Porter—Memoirs of Sebastian Cabot—Marshall's Naval Operations in Ava, &c. &c.

GENERAL CORRESPONDENCE.

TO THE EDITOR OF THE UNITED SERVICE JOURNAL.

Suggestion for preventing accidents by Steamers.

MR. EDITOR,—You cannot but have observed in the papers, accounts of numerous accidents on the river, caused by steam-boats running over wharves, and you will not, perhaps, consider it unworthy of your Journal to give insertion to a suggestion on the subject, by a due attention to which many, if not all, of these accidents, might be avoided.

In America, in all the steam-boats the helmsman, instead of being placed abaft, close to the taffrail, in a low situation, from which he can see nothing, is raised on a high platform, within a few feet of the bows, from whence he commands a view, not only a-head and on both sides, but he can see the smallest boats, even when close to the vessel's cutwater.

The advantages of having the steersman in the situation described, are very considerable. In the first place, as I have already observed, he has a complete view of all objects in front of him, and this view cannot be intercepted by the passengers coming in his way. In the next place, it enables him to steer with much greater precision amongst the boats, ships, or buoys, which happen to lie in his course; and it is infinitely easier for him to avoid running over little boats, when he himself can distinctly see what those boats are about. As things are at present arranged, the captain, placed on the paddle-box, or on the bowsprit, calls out to the helmsman to alter the course, and the word has to be passed along from mouth to mouth in a most inconvenient manner.

In America, the captain or the pilot stands alongside the wheel, which is raised, as I have mentioned, on a platform, at the height of ten or twelve

feet above the deck, and far forwards. He there gives his directions quietly and distinctly to the helmsman at his elbow; or, if need be, he takes hold of the wheel himself. In any event, the wretched bawling and uproar which at present exist in our boats would be saved, and the passengers would be spared the eternal injunctions to keep out of the helmsman's way.

It may be added too, that under the circumstances above described, of steering in the bow instead of abaft, the rate of moving of the steam-boat may be greatly accelerated with perfect safety, and the reason is obvious. When the person who is guiding the movements of the boat sees his way distinctly, he can venture to run much faster than he now does, when he is virtually blindfolded.

At night, the advantages of steering a steam-boat in the bows are still more important. On the Mississippi it would be impossible, were the steam-boats not so fitted, to navigate amongst the floating logs, and the fixed snags, as the trees are called which lie with their roots in the mud, and their sharp tops pointed down the stream. But by having the pilot (who I may mention, always actually, with his own hands, steers the vessel in America,) in the bow, and well raised on a platform, all these obstacles can be avoided, even in very dark nights. I need not point out to you how eminently useful the same simple device would be in navigating the river Thames at night, or in foggy, rainy, or blowing weather.

I call the device a simple one, because it absolutely requires no change of principle, and is capable of being adopted in every boat at the expense of half an hour's work for a couple of seamen, and half a day's work for two or three carpenters.

All that is requisite is, to have a small platform or scaffold, eight feet square, raised about ten feet or twelve feet above the deck, at the distance of ten or twelve feet from the stem. On this let the wheel be placed, and let the tiller ropes, after passing round the barrel, be led through blocks in the deck beneath, and again through blocks or sheeve boles on the bulwark, low down. The ropes then stretch along outside, and are supported on fair leaders or rollers till they reach blocks above the counter, and being rove through these, they are made fast to the end of the tiller, which it is best to ship abaft the rudder, so as to keep the poop or quarterdeck quite clear for the passengers, and to prevent the possibility of anything coming in the way of the tiller.

It is well to have those parts of the tiller ropes which cross the fore part of the deck, enclosed in what is called a trunk, or wooden pipe, to prevent injury from the feet of persons passing to and fro, or interruption from things lying about the decks.

It might at first be supposed, that the great additional length of the tiller ropes, and the distance of the wheel from the rudder, might make it difficult to steer the vessel. Such, however, is not the fact, as I can testify from having myself steered many steam-boats in America, of from three to four hundred tons burthen, and with perfect ease.

Practically speaking, therefore, there is no objection to the adoption of this method of steering our river steam-boats, and the expense must be quite immaterial; and I venture to prophesy, that the instant the plan is adopted by any one vessel, the advantages will be found so great, it will be generally adopted by them all.

For sea-going steam-boats, this method of steering is not so necessary, nor would it be quite so easy of adoption. But all steam-boats which perform part of their voyage at sea and part on rivers, such as the Edinburgh and Leith vessels, might very readily be fitted with two wheels and two sets of tiller ropes; one abaft, as at present, to be used at sea; the other elevated on a platform to be brought into play on entering the river.

If you think this communication worthy of a place in your Journal, I shall be glad to send you, for your next month's Number, another plan for the further improvement of steam navigation in rivers;—not a fanciful scheme,

but one which has been for years in use on the Tay, with such great advantage, that I have often wondered why it was not universally adopted.

I remain your most obedient servant,
 BASIL HALL, Capt. R.N.

Judge Johnson's Military Law.

MR. EDITOR,—I observe that the opinion lately given by Judge Johnson, in answer to a question by Sir William Cox, one of the Grand Jury at the Wexford Assizes, "That in case an officer should give an illegal order to his men to fire on a mob, any soldier obeying the order would likewise be amenable for the offence," is questioned by "an Officer" in the Times newspaper of this day; but that the Editor of that very "Liberal and Patriotic Print" states the opinion to be "perfectly correct." Surely that highly-gifted gentleman is for *once* in error; and if I am not mistaken, you will take every means of counteracting the evils likely to arise from the propagation of an opinion so mischievous to the service.

In the Articles of War, under the head of "Crimes punishable with Death; Transportation," &c., I find (Clause 13) included, "Any officer or soldier who shall disobey the lawful command of his superior officer," but it never was intended, and it never will be recognised, that a soldier is to question the legality of the commands of his officer, or that he shall be punished for obeying them. I have at this moment some instructions lately issued from the Horse-Guards, and the maxim under the head of "Articles of War" is, "OBEDIENCE IS THE FIRST DUTY OF A SOLDIER." I do not think they have yet appeared in your Journal, and I therefore enclose an extract, the publication of which may be serviceable.

"ARTICLES OF WAR.

"OBEDIENCE IS THE FIRST DUTY OF A SOLDIER.

"For the following offences, the Articles of War inflict on the soldier the penalty of death, or such other punishment as a Court-Martial may award.

"Mutiny.—Desertion.—Cowardice.—Holding correspondence with the enemy.—Quitting his post in search of plunder.—Personal violence to a superior, or disobedience of his lawful commands.—Forcing a safe-guard.—Betraying the watchword.—Giving false alarms.—Casting away arms or ammunition.—Sleeping on, or quitting his post.

"For the following offences, a soldier is liable to be punished by transportation, or general service, or corporal punishment, and, in addition to any other punishment, by forfeiture of all claim to pension on discharge, and of all additional pay whilst serving.

"Using traitorous words against the King or Royal Family.—Persuading to desert, or harbouring a deserter.—Being drunk on duty.—Breaking arrest.—Giving a different watchword.—Spreading false reports in the field.—In action, or previous to action, using words tending to create alarm.—Quitting ranks without leave.—Being made prisoner by neglect.—Seizing supplies.—Disgraceful and vicious conduct.—Refusing assistance to, or impeding the Provost Marshal.—Embezzling or misapplying money or stores.

"For the following offences, a soldier is to be punished according to the nature and degree of the offence.

"Speaking to the hurt or dishonour of the general, or other commander-in-chief of the forces.—Neglect of orders on duty.—Hiring another person to do his duty without authority.—Absence from parade.—Giving false alarms at home by discharging fire-arms, &c.—Lying out of quarters.—Being found one mile from the camp, without leave.—Permitting baggage-waggons, or carriages, to be overloaded.—Selling, losing, or spoiling his arms, accoutrements, or necessaries.—Selling, losing, or ill-treating his horse.—Committing waste, or destroying property.—Non-commissioned officer striking or ill-treating a soldier.—Vexatious appeal from a regimental court martial.—Any non-commissioned officer, or soldier, convicted of embezzling or misapplying money intrusted to him, is to be put under stoppages until the money is made good.

"A soldier convicted of malingering, of feigning, or producing disease, of injuring

his health by vice or intemperance, of absenting himself from hospital whilst under medical treatment, or of a gross violation of the rules of the hospital, may be tried for disgraceful conduct, and shall be subjected to the pains and penalties attached to that offence; and a soldier convicted of disgraceful conduct, having been once previously convicted of an offence of a disgraceful character, or of offences which render him unworthy to be retained in the army, may, in addition to any other punishment, be discharged with ignominy, and will thereby forfeit all claim to pension, or allowance on discharge.

“ A soldier who shall become maimed or mutilated by the firing off of his musket, or by any other means, is to be tried by a court-martial, and if it be found by the Court that the maiming or mutilating was the effect of design, he shall not be discharged, but shall be employed on military work. If a soldier tamper with his eyes, or by vice, intemperance, or misconduct, shall cause the total or partial loss of his sight, he shall not be entitled to his discharge, or to a pension, but shall be detained in an eye infirmary.

“ A soldier convicted of having been four times drunk within twelve months, or twice drunk when for parade or duty, within twelve months, may be deprived of his additional pay, or of the allowance in lieu of beer, for a period not exceeding two years.

“ Any person having been discharged from the army, who shall re-enlist, and when questioned by the magistrate at the time of being attested, shall conceal or misrepresent the cause of his discharge, shall not reckon his past service, nor be allowed a pension, if again discharged for disability.

“ All crimes not capital, and all disorders and neglects which soldiers may be guilty of, to the prejudice of military discipline, though not specified in the Articles of War, are to be taken cognizance of by courts-martial, and punished according to the nature and degree of the offence.

“ COMPLAINTS.

“ When a soldier has any complaint to make, he should appeal to the Captain of his Company; his tone and manner should be temperate and respectful; and if he prefers to be accompanied by a non-commissioned officer, he should request a sergeant of the company to go with him. No soldier, on any account, is to presume to make a complaint to his officer for another soldier who conceives he is aggrieved; and not more than two soldiers should approach the officer, to make a complaint at one and the same time.”

25th July 1831.

ANTI-RADICAL.

“ * * * We believe there is but one opinion in the service, and amongst all sober-minded persons out of it, as to the misapplication and mischievous tendency of the dogma so unadvisedly propounded by the Irish Judge. The latter, and civilians in general, forget that the army is and must be governed by a separate code, which is annually sanctioned by the Legislature, under the title of the Mutiny Act. The extract we have given above, from the Articles of War, taken in its obvious spirit, will prove the sophistry, and, we trust, prevent the disorganizing effects of an opinion, which, in the case of the soldier, is equally irreconcilable with fact, expediency, and common sense.—ED.

Comments on “ *The Distribution and Duties of the Medical Staff of the Army.*”*

MR. EDITOR,—I have perused in your entertaining Journal for June 1831, certain observations, signed “ a Medical Officer,” “ on the Distribution and Duties of the *unattached* Medical Staff of the Army at home;” and to whom, *Irish like*, though UNATTACHED, he gives DUTIES and STATIONS to in a sort of tabular form, the compilation of which he declares gave him great trouble in coming at the truth. He also, with a continued trifle of the *bull* in him, tells you that the titles of Director-General, Principal Inspector-Ge-

* See our Number for June.

neral, Physician-General, and Surgeon-General, have now become obsolete under the present regulation, dated 29th of July 1830; yet in said tabular form our compiler includes *Assistant Inspectors* and *Assistant Staff Surgeons* as persons at present on full pay. Now, a word would tell him, that the Royal Warrant of George the Third, dated 22nd May 1804, ordered all *Assistant Inspectors* from thenceforth to be dubbed *Deputy Inspectors of Hospitals*; and that the Royal Warrant of our good King William the Fourth, dated 29th July 1830, made all *Deputy Inspectors* to be "*Deputy Inspectors General*;" and that all "*Assistant Staff Surgeons*" should be lopped in their honours, inasmuch as the word *STAFF* should be reduced, and the rank in future to be simply "*Assistant Surgeons*" to the Forces! And now, with great submission, let me say, that a moment's consideration will easily evince how far this tabular form of duties and distribution, "made up to April 1831," is, or is not, what it should be, if *actual* truth and fair observation were the breaches through which the general attack had been made.

I freely allow "the London Medical Board" consists of a senior and junior officer; the one, "Director General" at £2000 a-year, and the other, "Principal Inspector" at £1200 a-year; and the *compiler* is requested to say, who may be "the *Assistant Inspector*?" The Secretary of the London Medical Board, as per Monthly Army List, comes in rank immediately after the Director General and Principal Inspector; and "*the Professional Assistant*," (an extra rank most certainly of no class,) is ranked after the Secretary! Of course, all connexion with the Army Medical Board, London, means simply that he is an officer of the Board, of a particular character, and is in junior rank to the Secretary.

We may all admit that a "*Staff Surgeon*" is a very good, a very correct, and a very called for, medical officer in a town or in a city where a larger garrison than one or two regiments is usually stationed, to receive the orders of the Metropolitan Medical Board, and to superintend the medical and financial regulations of the several corps placed under his control, giving his professional advice and assistance where ordered, and where in consequence necessary, for the observance of the regimental medical officers. In many of the stations enumerated in the "*Tabular Distribution*," I must acquaint the compiler thereof, that the *Staff Surgeon* is attached to a "*Recruiting District*," and as such is merely the Medical Staff Officer annexed to a local duty, without reference to or interference with the surrounding district; and as an allusion is here made to "*Surgeons of Recruiting Districts*," who, at the commencement of the rank, were an isolated body of men, at ten shillings a-day pay, it may not be inappropriate to observe, that all the surgeons appointed thereto in Ireland, were named and gazetted under the immediate authority of the London Medical Board, although probably it may be found that the Dublin Medical Board was in active operation before the conflicting materials, of which the London Board was formed, could be brought into action.

The Pay Warrant of 1797 originated with the Dublin Medical Board; that of 1804 was the work of the London Medical Board; and the recent Pay Warrant of July 1830 emanated from "The War Department" solely.

Our worthy "*compiler*" will see, in reading over the foregoing passages, that a strange anomaly has been acted upon in Ireland for many years past, namely, the service of two Medical Staffs in that land of "Job"—the Irish Army Medical Staff, and the Staff forced into the country as the "*Recruiting District Staff*!" Not another word upon the subject is needful; but it may with great honesty be added, that the *original possessor* of the *Recruiting Depôts* was from time to time placed upon half-pay; and "*the Surgeon to the Forces*," nay "*the Deputy-Inspector-General of Hospitals*," are now doing duty in Ireland as "*District Surgeons*." Oh, that our "*compiler*" were acquainted with these and some other little facts! Let him look to Newry district!

The "*Assistant Staff Surgeons*," now so *very correctly* given in the "*Tabular Form of Distribution*," as doing duty at Chatham, may also be brought

forward for an observation or two. It is quite ridiculous to put them down for *duty* at that place. They are merely sent there to await the calls of service, and to give the *young medical recruit* an idea of duty, as well as to prevent his loitering his time in London for orders of eventual disposal.

To follow, however, the observations of our worthy "compiler" throughout the various grades of his disquisitions upon the English Army Medical Concerns, would answer no good purpose. It is to be much suspected, and it is really to be regretted, that the loaves and fishes seem to swim before his eyes; were he to come forward and attack *measures*, without noticing the men in employ, he *might*, and it *might* reasonably be expected that he would and must, do good to the service. For instance, take up the *dieting* of the sick soldier. Let him give his opinion how far *HALF A POUND* of *boiled potatoes* would appear a cheering accompaniment to a convalescent *Irish or Scots* soldier, when he gets his cut of boiled beef for dinner, and how the stomach of such a "*gourmand*" could stand the allowance of two tea spoonfuls of milk to his Congou at breakfast! Let our *compiler* come at a few of those *desiderata* for the recovery of the sick soldier, and his good intentions will tell. There are, to be sure, a list of mighty fine extras allowed; but the Regimental Surgeon in Ireland keeps those *kind exceptions* from the *knowledge* of the soldier. Were the soldier aware of them, he could, and certainly would, annoy the Regimental Medical Officer; and I may with great truth say, that if the soldier's *option* in *hospital diet* was attended to, "*agreeably to regulation*," a pound sterling a-day would not cover his hospital stoppage of tenpence! Let it be recollected that the service in *Ireland* is here solely alluded to *under* this head.

At this place it may not be very foreign to remark, that "our compiler," in observations upon "Head Quarters, London," says, it would be well if the members of the Army Medical Board had each respectively his defined office duties to perform. He knows not that under Mr. Keate, Sir Lucas Pepys, and Mr. Knight, this notable expedient was fully tried, weighed, and found deficient. The "*Surgeon-General*" could take his Assistant-Surgeons and Surgeons, and his higher officers, from the Hospital Mates, from the Assistant Surgeons, and from Surgeons of Regiments. The "*Physician-General*" had the appointing of Dispensers of Medicines, of Apothecaries, and of Physicians to the Forces; and the "*Inspector-General*" could appoint Hospital Mates, Purveyor's Clerks, Deputy Purveyors, and Purveyors of Hospitals. The first collision took place between Mr. Keate and Mr. Knight—the latter had the appointment of the *Hospital Mates*, and Mr. Keate was obliged to take his *Assistant-Surgeons* from the *Hospital Mates*, or appoint *Assistant Surgeons* direct to regiments who never had been *Hospital Mates*. This frequently occurred, and the *Regimental Surgeon* himself has been appointed when he never had been either *Hospital Mate* or *Assistant-Surgeon*!

So much for *London Jobbing* and *immaculate* conduct in office regulation. The fate attending such prosperous doings was easily anticipated; and the change brought forward old Mr. Weir to the head of affairs, and after him succeeded the present dynasty in Berkeley Street.

And now to come to *Jobbing Ireland*. It is to be stated, that the Army Medical Department in Dublin acknowledges but one chief, and that is the present Director-General of Hospitals, Doctor George Renny, on whom it is with pleasure confessed, that *our compiler* has passed an eulogium, but which eulogium is no more than what truth and fair reasoning would entitle that truly honest man to receive. This gentleman serves as "Chief of the Army Medical Department in Ireland" since June 1795, and his salary is 866*l.* 17*s.* 6*d.* a year. He has not more than four clerks in his office, and controls the entire of the General and Regimental Military Hospitals in Ireland, upwards of sixty in number, by monthly accounts, comprising a sum of upwards of 26,000*l.* yearly, to be checked and regularly audited, and reported upon to head-quarters.

He has one "Deputy-Inspector-General of Hospitals," as his first Staff

medical officer, and with vast submission to *our compiler*, it must be recollected, that the person who now fills that situation was appointed a "*Staff-Surgeon*" in the year 1795, was promoted to the rank of "*Assistant-Inspector*" in 1803, and no doubt would have remained at said rank ever since, had it not been that our deceased gracious Sovereign George the Third did by his Royal Warrant, dated at St. James's the 22nd of May 1804, enjoin and order that the rank of "*Assistant-Inspector*" should cease, and that all officers of that rank should thenceforward be called and approved "*Deputy-Inspectors of Hospitals*." And at this latter rank he remained, until our present beloved King, William the Fourth, by his Royal Warrant of July 1830, made all the *Deputy-Inspectors* to have the additional title of "*GENERAL*."

The Staff medical duty at Dublin is peculiar to itself, and can only be known to those employed on the station. And our *compiler's* remarks about "*Sick Certificates*" and "*Medical Boards*," contain more *venom* in the way of the "*loaves and fishes*," than almost at any other part of his lucubrations breaks forth!

In answer to our *compiler's* remarks, as to the Physician-General and Surgeon-General in Ireland, it is simply necessary to observe, that on the reduction of the Army Medical Board in Dublin, in the year 1816, which consisted of the *Physician-General*, *Surgeon-General*, and *Director-General of Hospitals*, the *Physician-General* and *Surgeon-General* were reduced as members of said Board, and the entire of the duties, both medical and financial, were placed under the sole and absolute control of the *Director-General of Hospitals*. And the duties of the *Physician-General* and *Surgeon-General* retrograded, or went back to the medical and surgical services they had to perform before the Establishment of the *Medical Board* in 1795; namely—their professional attendance on the *General Military Hospitals* in Dublin, oftentimes, and for years together, *two* and even *three* in number, besides the present *General Military Hospital* in the *Phoenix Park*. In a word, to prove the assertion beyond yea or nay, it may be as well to name them—they are not so many years broken up, but that two of these additional *Hospitals* must be in instant recollection.

1st. The upper wards of "*Steevens's Hospital*" were hired for the accommodation of sick soldiers, holding generally 200 patients.

2nd. The "*Convalescent General Military Hospital*," on *Arbor Hill*, containing seldom under seventy-five patients.

The *Medical General* at *Cork* has the same good fortune to thank for his promotion as our *Dublin General* had, and no doubt *our worthy compiler* looks upon him with equal love and kindness for his removal to a better staff! But enough has been said to prove, that if reform is wanting in the *Army Medical Department* of his Majesty's service, it is not at the *individuals* employed the *pecking* should be first made—but at measures. The officer in command of a regiment is now *bona fide* the *Surgeon*! and too often interposes his opinions on remedial measures, as well as in other matters it were quite as well to be silent about. . . But so it is well known!

And now a few words upon our friendly *compiler's* hints at economy, and Mr. Editor I shall bid you good night. Suppose, as Ireland seems in his opinion the *genuine land of jobbing*, the economy system commenced here, and the *present incumbents* were sent to the *left about* and put upon half-pay, or rather, it would be whole pay from their length of service. Surely the *fresh feeders* on the *public purse* must be paid. The men in office are old, but they are yet able to work; and if this single point be once admitted, and surely to every unbiassed character it must, where can the saving be of putting by the *old* before *worn out*, and using the *new*? A due consideration of the "*DEAD WEIGHT*" will answer all farther questions.

I am yours, &c.

SENEX.

P. S. It may be well to add, that there is no "*Staff-Surgeon*" serving

on the Irish Medical Staff. Those of that rank on service in Ireland are attached to "Recruiting Districts," and were appointed thereto, as before said, by the English Army Medical Department.

Comforts of Midshipmen Afloat.

MR. EDITOR,—In these days of reform, I hope a few remarks on the present state of the Mids in His Majesty's service may not be considered too trifling for a place in your valuable Journal.

The Lords Commissioners of the Admiralty have, in the most praiseworthy manner, turned their attention to the amelioration of the condition of that class of officers, and no doubt their care and attention has tended greatly to an improved state of society and respectability in our noble profession; and there is, I hope and trust, a heartfelt pride glowing within the breasts of these rising Nelsons; but do not let our old officers imagine from this I would impugn them in the slightest degree. No one can revere the reapers of our last war's glorious harvest more than myself; but I doubt not they will themselves acknowledge that an improvement has taken place in our service generally, and I feel persuaded they will see no cause to be offended at the remark.

The point to which I am now coming will at first appear trifling, but conviction satisfies me of its importance. I allude to the respectable appearance of the Mids in His Majesty's service, which, if not essentially requisite, is unquestionably very desirable. With a view to this end, it is of course necessary they should be allowed a chest to contain their clothes and washing apparatus. Now, although the custom of the service has for many years past, and does still sanction their possessing such an article, it has never been officially granted them, and their chests are therefore at the disposal, I may say, of their Captain, who alters their size, or even destroys them, at his pleasure.

First. With regard to altering their size, suppose a Midshipman having a chest full of clothes which he has been allowed in his last ship should remove to another, on a foreign station particularly, and the Captain should order his chest to be razéed, he must in consequence lose, spoil, or sell a portion of his kit, which is a loss many in our service are unable to afford.

Secondly. Suppose his chest broken up and a bag substituted, with the addition, perhaps, of a small drawer to contain his washing traps, how is it possible he can appear on the quarter-deck like an officer or a gentleman; and besides, the chances are a kit that cost from 60*l.* to 100*l.* is totally ruined in three weeks.

The first of these cases has continually taken place, and is still of common occurrence, and chiefly for the sake of uniformity and regularity of appearance. The second, I believe, (and for the credit of our service I hope,) is of *very rare* occurrence, although I am most credibly informed of its having taken place within the last three years.

The proposal I would therefore make is, that the Admiralty do appoint a size of chest to be *allowed* throughout the service, by doing which they would obviate the difficulty, and I may almost say injustice of the former, and effectually crush the tyranny of the latter.

Captains, Lieutenants, and Warrant Officers are allowed cabins for their clothes and comfort, and I think the Mids may with justice claim a chest. I can only add, that the above remarks may be useful, or tend eventually to the comfort of the Mids in His Majesty's service, is the sincere wish of your constant reader and admirer,

HAM.

Charge of the 23rd Light Dragoons at Talavera.

MR. EDITOR,—In your United Service Journal for July, I observe a letter from a "Talavera Man," relative to the charge made by the late 23rd Dragoons at the battle of Talavera. Will you permit me to mention what

I observed on that occasion? In this battle, I was a Subaltern of the Light Company of the left regiment of Hill's division, and was in consequence in a very good situation to view the charge in question, being placed on the left of the hill, well known by the name of "Hill's hill."

On this part of the British line the French had made some most determined attacks on the morning of the 28th, as well as the previous night and afternoon, and it was with considerable fear for the safety of our hill, that I observed, towards evening, some heavy columns of French preparing to renew their attacks on our division, already very much reduced in numbers, and those that remained, not over well fed during the previous twenty-four hours. We had scarcely stood up from the ground to receive the attack of those columns, (one of which was in the act of deploying,) when a heavy body of British cavalry came into the valley on the left of my company, and had not been long there before a charge was ordered; being at the time a very young soldier, and not before having the good fortune to see cavalry preparing for this sort of work, the sight had an impression on me which I shall never forget, but which, I suppose, every soldier has occasionally. The 23rd, which was in front, advanced in the most splendid order, but before they went far, we had the unhappiness to perceive them entirely broken, by what afterwards appeared to be *the dry bed* of a rivulet, and which each man crossed over as well as he could. After such an event, it was not possible *even for the 23rd* to make an impression on a column of French veterans, and which by this time was in square. I am, therefore, very sorry to differ with your Talavera Correspondent, but must assert that *I did not see the 23rd Dragoons charge through* this column.

I am fully persuaded that if any Light Dragoons, or, indeed, Dragoons of any description, could have broken that fine body of French infantry, formed as they then were, the 23rd would have done it; however, from the moment they came in contact with the bed of the rivulet before mentioned, this corps did not appear to me to be in a state to attack the most inexperienced infantry; and although many went on after this unfortunate occurrence in the most gallant manner, yet, I fear, it was merely a useless sacrifice of life, as I did not see them touch a single man *in column*. Still, although by this unforeseen misfortune, the 23rd did not succeed in their charge, yet the General-in-Chief fully succeeded in his object, as the spirit which this corps had shown certainly deterred the enemy from repeating their attacks on our hill.

I am, yours, &c.

A LIEUTENANT-COLONEL (Unattached).

J. U. Service Club, 18th July, 1831.

Suggestion for a United Service Retreat.

MR. EDITOR,—Your valuable and ably conducted Journal has proved both an honour and a benefit to the "United Service." It has shown that Science is a twin sister with Valour, and that Learning can march hand in hand with Loyalty; while at the same time I think you must have convinced even the "reading public," that there is knowledge in the camp as well as in the schools. Some of the most able and useful papers that were ever written have appeared in the pages of your Journal,* and written, too, by officers of the "United Service." Let us always be thus *united*, and those who envy England her greatness and her glory, whether they come in the shape of a MINERVA or a MARS, will ever find us with our "lamps burning."

* While we confess that our modesty is a little ruffled by the strength of these compliments, we are, of course, the last who should be insensible to their faithful application. In justice to ourselves, therefore, and to the acuteness of our correspondent, we give, as we are bound to do, his complimentary opinions without retrenchment; we aspire to no more legitimate reward than "*laudari à laudato*."
—Ed.

It is not, however, for the purpose of adding my very feeble note of praise to that which the united nations, as well as the services of the empire, have so justly awarded you, but simply to submit to your readers a plan, (which I have long considered, and which I think practicable,) for establishing at a short distance from London, "Au Asylum," to be called "The United Service Retreat;" where those officers and men of His Majesty's Army and Navy, (whom the contingencies of the service, wounds, or accidents, have reduced to a *helpless or hopeless state of insanity*,) may be received and treated with all that kindness which humanity can suggest, and all the attention and care their disease requires; and where they may enjoy to their fullest extent, the improvements that have been discovered by science and experience in the treatment of those diseases that affect the regular or reasonable manifestations of the human mind.

With such an Asylum I think the Museum and other scientific establishments might be advantageously connected; and instead of the gloomy prison which our legislators and magistrates will still persist in building and providing for the security and *comfort*, as they suppose, of the insane in civil life, we should have a cheerful establishment, endowed with all the comforts, many of the superior embellishments, and all the inducements, that can lead the mind back to happiness and tranquillity, lessen the horror of a necessary seclusion, or alleviate sufferings, whether real or imaginary.

To such an establishment I conceive we might not only have apartments attached for a Museum and Library, but also a Zoological and Botanical Garden; all of which could be kept in order and superintended by the patients of this Asylum; ay, and ably too, under the management and direction of one or two able professors and a very few assistants.

Most of your readers are no doubt aware, that there is a mad-house for the Military at Fort Clarence, near Chatham, and a Naval asylum connected with Haslar Hospital. Yes, Sir, much credit is due to Sir William Burnett and Sir James M'Grigor, for the exertions they have made to rescue the officers and men of His Majesty's service from the fangs of those merciless contractors for the prolongation of human misery, the private mad-house keepers in and near the metropolis; and though the one could only get *the dungeons of a military fort*, and the other the outskirts of a naval hospital, they have contrived to render both establishments as respectable as the circumstances in each case would admit of. They have made them in some respects "comfortable asylums," though as yet they are not, and, indeed, they never can be, *hospitals for the cure of disease*.

Now, "the United Service Retreat" which I propose to establish, will have all the advantages of a college, "a miniature *Jardin des Plantes*," where instruction will be given and received,—of an hospital where the disease can be practically studied, and the nature and attributes of man and of animals inquired into and developed, without those disgusting accompaniments of mummery and mystery, that are so disgraceful and unworthy of this enlightened age in which we live.

This establishment, Sir, might be raised at a very trifling expense, and should be open to all officers and men of both services while in a state of derangement—their wives and children. And, believe me, when once completed, it will in a great measure maintain itself; that is, the fees of pupils, the charge for showing the Zoological and Botanical Gardens and the Museum, will greatly diminish the sums to be paid by the patients; and the great advantage of such an hospital will soon cause applications to be made from wealthy patients, whose payments will abundantly provide for many destitute widows and orphans of officers, that otherwise could not have had the advantages of such a place.

I shall not intrude farther upon your pages for the present, but if you approve of my suggestion, I shall next enter fully into the details of the measure.

I have the honour to be, Sir,

Your constant reader and admirer,

MILLO.

The British Cavalry.

“The result of a hundred battles, and the testimony of impartial writers of different nations, have given the first place amongst the European infantry to the British; but in a comparison between the troops of France and England, it would be unjust not to admit, that the cavalry of the former stands higher in the estimation of the world.”—*Vide Napier's Peninsular War, vol. 3, page 272.*

MR. EDITOR,—In reading the third volume of Colonel Napier's valuable work, I was struck with the passage quoted above, and as it is to be feared the mere publication of such a statement by an author of his celebrity, may tend to strengthen a very unfounded prejudice, I venture to call your attention to the subject, in the hope that you will collect and publish from time to time, *authentic and detailed* accounts of the conduct of the British cavalry during the war in the Peninsula and the South of France, and by this means place its character in a truer light. It might have been expected that Colonel Napier, (who must have had frequent opportunities of witnessing the conduct of our cavalry in the field,) would not have rested satisfied with giving currency to such an opinion by barely stating it, but that he would have attempted, at least, to expose its falsity, and restore the cavalry of his country to the station it is entitled to occupy in the estimation of the world. As he has not adopted this natural and becoming course, I may be permitted to offer a few remarks on the relative merits of the cavalry of the two nations. The British may be considered inferior to their rivals in an acquaintance with certain points of the duty of the outposts; but this is to be taken with much limitation, and is perhaps chiefly, if not entirely, to be ascribed to a want of equal opportunities of acquiring experience on actual service. The men are also more apt to be carried away by their eagerness in pursuit, after a successful charge; and this impetuosity has sometimes exposed them to suffer severe loss from a beaten enemy. The habit of campaigning would soon correct this fault, which is shared with them by our infantry. The French are notorious for bad horsemanship and neglect of their horses; the British the reverse. In every other respect, I believe, our cavalry to be superior, not only to the French, but to that of every other nation. I am confident, that when well commanded, no cavalry can withstand their charge; and Colonel Napier's own book affords ample proof of the opinion here advanced, as far as it regards the French; for in nine cases out of ten which he has recorded, where the cavalry of the two nations are opposed to each other, the advantage is with the British, although, in general, far inferior in numbers.

If our cavalry did not act so prominent a part in the decision of general battles, and the destruction of beaten armies, as might have been expected from these premises, this failure must be ascribed to other causes than inferiority in the troops. It is sufficient to refer to the actions of that cavalry, when led by a Paget, a Stewart, or a Ponsonby, to be convinced that it was capable of any achievement. But the Duke of Wellington was averse to risk his cavalry (never sufficiently numerous), on account of the difficulty of replacing any serious loss in that description of force; and under some officers, who were most unaccountably entrusted with commands, it would have been worse than folly to expect vigour or enterprise.

I am, Sir, Your obedient servant,

A. G.

Case of John Shipp, late 87th Regiment.

MR. EDITOR,—I do believe that where bravery exists benevolence is sure to be found: from this conviction I proceed to state my case, reposing in the confidence that this appeal to your humanity will not be made in vain. There are no people who can appreciate the life of a soldier, but those who have followed the profession through all its chequered wanderings. That

mine has been a career of peculiar trial and privation, all must acknowledge. The sad wind-up is as extraordinary and distressing as its commencement. The incidents of my life I published in the year 1829, and it met a ready sale; but its profits were swallowed up in the enormous expense of publication. Another edition was called for: I published an enlarged one, adding to it my humble "Advice to Young Officers entering on their Military Career," with many other useful hints.

Six hundred and fifty copies, incumbered with a great portion of the expenses of its publication, are still on hand; and, in all probability, the life dedicated to my country for the long period of thirty-three years—during which time I led four forlorn-hopes, and received six ball-wounds*—will be consumed in a prison, if gentlemen do not become purchasers of my works, viz. "My own Life" and the "Military Bijou:" the former was published in three volumes at thirty shillings, and the latter in two volumes at fifteen shillings. I now require no profit on them; the liquidation of the debt incurred in the publication being my principal aim, and the desire of terminating my days in peace, my highest hope. Both works may be had of me at the reduced price of one pound, or, separately, the *Life* at fifteen shillings, and the *Military Bijou* at seven shillings, in boards. All orders addressed to me, by post, will be gratefully received and instantly attended to.

I remain, Mr. Editor,

Your obedient humble servant,

JOHN SHIPP,

Late Lieutenant 87th Regiment.

Ealing, Middlesex, June 1831.

*** We trust that our insertion of the above may serve the interests of the writer.—Ed.

Badge of Merit.

MR. EDITOR, —Having just read the remarks of your intelligent Correspondent L. L. L. in the *United Service Journal* for January last, relative to a Badge of Merit, I beg to offer a few observations upon the subject for the consideration of those who have already taken so lively an interest in this most desirable object.

What is everybody's business is no one's business, and unless His Majesty, or those to whom it may be referred, clearly see their way, and some simple plan is pointed out without putting the public to any expense in these times of great pressure of business and economy, there is reason to fear, that although there might not be any possible objection to the principle of the thing, it might never be accomplished, particularly if it was found to occupy too much of the valuable time of those in official situations—it therefore appears to me, that a Committee should be formed of Navy and Army officers of either of the Club-houses, to fix upon the design for a Badge, and draft of a Memorial, to be submitted to His Majesty. The only difference I would propose in the Badge is, that in place of the lion, a crown and anchor might be more appropriate for the Navy; and the King's arms, or usual military trophies for the Army. It sometimes happens that an officer having served in both Navy and Army has been engaged in some celebrated naval action, and distinguished himself in storming forts, upon satisfactory proof of which he should be allowed to wear both the naval and military badge. And such officers on half-pay in the Navy, Army, and East India service, as have the privilege of attending His Majesty's Levees, and are permitted to wear a badge for distinguished services, should be allowed, upon those or any other public occasions, to wear an appropriate blue coat (like the cavalry dress,) with a suitable gilt button, for it does not look well to see medals upon any sort of coat, and it will give those on half-pay, who invariably appear in plain clothes, an opportunity of wearing their badges on particular

* These wounds having been received when I was a non-commissioned officer, I am unable to claim the bounty to which a commissioned officer would be entitled.

occasions, many of whom will otherwise never put them on, from a notion, that it is not becoming to wear them with plain clothes, which I confess accords with my own ideas, as I have a medal for services performed about thirty years ago, but have not worn it ever since the peace, being on half-pay, and having no regimentals.

Should His Majesty be graciously pleased to comply with the request of the United Services, and signify his pleasure in the Gazette, to whom each officer's statement of services should be forwarded, I would submit that it may be done in the following form, which is simple, and yet, no doubt, will contain all the information that may be deemed necessary to satisfy His Majesty of the merits of the applicant to the honour he solicits.

Name and Rank of Officer when the Service was performed.	To what Ship or Regiment he belonged.	Date and Nature of Service.	Under whose Command.	Remarks: here state the best proof the Officer has to propose of his Services, by Certificates, Letters, or Extracts from Orders, &c.	Officer's present Address.

The form of badge being approved by His Majesty, the next step would be for the Committee to ascertain from some skilful and eminent Die-sinker, (Wyon, for instance,) the expense of the badge in gold, silver, and copper, which information might be communicated to the Service generally through your valuable Journal, with the address of the person who proposed to provide them, when any officer who may be desirous of wearing the badge, and having His Majesty's authority to do so, could signify to the contractor by letter, post free, the description of badge he was desirous of having, whether gold, silver, or copper, and give a reference to some friend or agent in town, who would receive and pay for the same, provided the badge was produced by the contractor within a stated time—as there are instances of persons making a convenience of such contracts, and are years in performing what might be done in a few months. By this arrangement, all parties will see their way most clearly, and the chief trouble, and all the expense, will fall upon those who are willing to bear it. I am, Sir,

9th July, 1831.

Your obedient servant,

A SUBSCRIBER.

Abstract of Officers who served in the Army on the Peninsula and at Waterloo.

MR. EDITOR,—I have lately seen some notice taken in the daily papers of the number of General and Field Officers remaining in the Army who were at the Battle of Waterloo, and subsequently one or two complaints of the junior ranks omitted in such notice.

With this you will receive Abstracts of the officers who served in the Peninsula and at the Battle of Waterloo, which you may be disposed to print in the United Service Journal.

It may perhaps be requisite that I should explain, that the officers of the late German Legion are included in each Abstract, and also that, many individuals being included in both Abstracts, the real number of officers who served in the Peninsula and at Waterloo, and of those remaining in service, is less than the totals of both the statements.

I am, Sir,

Your most humble servant,

16th July 1831.

T. B.

The "Micee" of Hindostan.

MR. EDITOR,—As a sound set of teeth is amongst the requisites most to be desired, either in the field or on a long voyage, by a man who would crack his hiscuit comfortably, the following hint, if you can find room for it, may possibly interest some one who can make it available.

Mr. Johnstone, in his "Indian Field Sports," tells us that the females of Hindostan,

"After they attain a certain age, or get married, use an application to stain their teeth black; this I also believe was and is used to destroy the tartar, and preserve the teeth and gums, which it certainly does. The time of life at which they first begin to use it, is when tartar collects most; and were it used solely for ornament, the young would all have their teeth black, which none of them ever have. This application is called *micee*; and what it is composed of I cannot say. Whatever it is, it destroys the tartar, hardens the gums, and makes the teeth of a jet black, without destroying the enamel."

Now, Sir, was this same "*micee*" submitted to the test of chemical analysis, if a mineral preparation, its component parts could be easily ascertained; if a vegetable one, some of your readers resident in India, may, perhaps, be enabled to obtain possession of the secret, thereby benefiting many of our brethren of "both arms," whose teeth may happen to hang rather loosely in their sockets; and I think it is very probable that its beneficial qualities may be found to exist entirely independent of the colouring matter, (for I fear few of my brother officers will be found willing to exchange even rotten teeth for the most sound and beautifully polished black ones ever exhibited,) and, if it is so, as I suspect, society in England may be materially benefited by the "*micee*" of Hindostan.

Plymouth, July 16th, 1831.

Yours truly,
NAUTICUS.

Military Punishments.

MR. EDITOR,—It has frequently been observed by myself and other military men, that the system of flogging in the army appears to have drawn upon itself the violent disapprobation and detestation of that most useful class of society, viz. newspaper editors.

Through the means of your valuable publication, I take the liberty of informing these bulwarks of public freedom, that their ignorance on the above mentioned subject is great in the extreme; and that their humane conjectures on the barbarity, causes, and effects, are totally groundless, and tend to show that however well versed they may be on other subjects; their inclinations have never led them to make any investigation from good authority into military affairs. Possibly they may be prompted by humanity; but it appears to me, that by this violent rating and animadversion of an evil—which punishment is in any shape, although a necessary one—an attempt is made to obtain favour in the eyes of cockneys and languishing damsels; however this may be, they would find it of infinite service to themselves and papers, were they to consider things in their proper light, and not thus expose their impotency by pelting sand at the figure of military justice.

MILES.

June 12th, 1831.

* * * It is not by the responsible editors of newspapers that these tales respecting military punishments are trumped up, though they are hound to be more vigilant in excluding such trumpery from their columns: they are the fabrication of the "gentlemen" of the Penny-a-line Press, who live upon their wits, and sell poison without labels to the public, for which they are manifestly indictable. It is unnecessary to add that the piquant paragraphs upon this stock topic, cooked up from time to time by these ingenious authors, are utterly at variance with the facts.—Ed.

EDITOR'S PORTFOLIO ;
OR
NAVAL AND MILITARY REGISTER.

AFFAIRS AT HOME AND ABROAD.

—The Second Reading of the Reform Bill has been carried, as expected, in the House of Commons, by a considerable majority. The Bill has since gone into Committee, where its progress, having been precipitated so far, from the inconsistency of its details, and the close scrutiny of its opponents, is but snail-paced. Were it not for the check its introduction has caused to the public and private transactions and trade of the country, we are persuaded that the first impatience and overcharged expectations regarding the success and benefits of this measure, would have subsided in comparative indifference and disappointment amongst those classes by whom its principle has been honestly advocated. To a certain extent, such has been the result of delay ; but the stagnation of business, and the unhealthy excitement of personal and public feeling consequent on its agitation, render it desirable that a question so fraught with present evil, and so doubtful as to future good, should be disposed of.

In FRANCE, the usual popular disturbances have taken place during the past month. The King has opened the newly-elected Parliament with a "strong" Speech—the most remarkable features of which are the announcement that the Belgian Fortresses constructed to menace France were to be dismantled, and that the Tri-colour Flag waved under the walls of Lisbon ! These declarations have naturally created much interest and discussion in

England. The Duke of Wellington, under whose direction the frontier Fortresses in question had been put into a state of defence, to provide against the probable aggressions of France, at an expense of 2,000,000*l.* sterling to this country, spoke warmly, in the House of Lords, on the impolicy and injustice of dismantling those safeguards, not only of Belgium, but of Northern Europe, against the restless ambition of France. His Grace also commented indignantly upon our abandonment of Portugal to the attacks of the same over-bearing power—attacks made upon grounds so frivolous and far-strained.

A couple of Frenchmen, resident in Lisbon, having offended against the laws of Portugal, were tried and sentenced by those laws ;—upon which a French squadron is dispatched to the Tagus, which, after committing various acts of petty piracy upon the Portuguese shipping in the offing—enters the Tagus with a flourish of the Tri-coloured Flag, and kidnaps the half-dozen ill-equipped craft—called the Portuguese Fleet, receiving, thereupon, the submission of our prostrate Ally.

Prince Leopold of Saxe-Cobourg has been formally inaugurated at Brussels as King of BELGIUM—by the title of Leopold I. His accession has been greeted with present acclamation. The demonstrations, however, on the part of Holland évince dissatisfaction, and threaten war.

POLAND.—Since the death of Count Diebitsch, and the assump-

tion of the command of the Russian army by Count Paskewitsch, nothing decisive has occurred between the main armies. The Polish Commander having marched upon Siedlec and Lublin, to annihilate Gen. Rudiger, critically posted on the Wieperz, failed, and was compelled to retreat, owing, as it was stated, to the treachery of a Polish general, who declined to co-operate—and a general cry of treason for some time pervaded and disturbed the army and Warsaw.

Gens. Gielgud and Chlapowski, who had been thrown into Lithuania with a considerable force, which, it was stated, had been subsequently augmented by the accession of insurgents to 40,000 men, were driven into Prussia, with a diminished force rated only at 2000 men, and twelve guns; this body is said to have been disarmed by the Prussian authorities. Gen. Gielgud had been assassinated by one of his own officers, who then fled. Prussia, it is farther stated, has openly declared itself as not neutral, but, from circumstances, merely inactive in this war.

The main Russian army, 80,000 strong, under the Field Marshal Count Paskewitsch, has concentrated at Plock and Vieszawy, where it is stated to have thrown bridges over the Vistula, and to have crossed in force to the other bank, with a view of attacking Warsaw from that side. The Generalissimo Skrzynecki has warned the capital of its critical situation, and having assembled a strong though inferior force near Modlin, observes the Russians. The drama appears drawing to its close.

LIEUTENANCY OF THE TOWER.—The Earl of Munster, at the nomination of His Grace the Duke of Wellington, Constable of the Tower, has been appointed by His Majesty, Lieutenant of that fortress, in the room of the late Gen. Loftus.

NAVAL AND MILITARY LIBRARY AND MUSEUM.—In our last Number we gave a full detail of the proceedings which took place at the General Meeting, convened for the purpose of organizing this desirable Institution. The Committee, then appointed, have met frequently during the past month, and are now on the eve of publishing, for general distribution, an Address to the Navy and Army, on the eminent advantages which will accrue from it to the United Service, together with a list of its present Members, (already amounting to nearly one thousand,) and Presentations to the Library, Museum and Model Rooms, which, considering the limited space of time that has elapsed since the issue of the first Circular, are considerable; among others, we may mention the munificent donation of Messrs. Colburn and Bentley, of 270 volumes. We have also reason to hope, that the Committee will at the same time be enabled to announce their having obtained the loan of a building for the temporary deposit of contributions. We may, therefore, now fairly congratulate the Services on the certainty of their shortly possessing a *Professional* Institution in the metropolis of their country, a desideratum of long standing.

ROYAL NAVAL SCHOOL.—We had prepared a full detail of the proceedings at the third General Meeting of officers of the Royal Navy and Marines, which took place on the 11th ult. to consider the best means of promoting the Establishment of the Royal Naval School. Want of space, however, precludes their insertion, and we must content ourselves by stating, that although a little difference of opinion has been manifested in some of its minor arrangements, the Institution progresses favourably. The splendid donation from the Rev. Dr. Bell of 10,000*l.* 3 per cent. Bank annuities, has been accepted subject to the terms specified by the donor. At the suggestion of Vice-Admiral Lambert, an addition of fifteen members has been made to the Council of Administration; Lieut. Charles Brand, R.N. has been appointed Secretary; and in consequence of a difficulty having arisen with the bankers to receive small subscriptions, all the Navy and Marine

Agents in London have undertaken to receive from their clients and others, any sums they may please to subscribe, and will from time to time account for the same to the Secretary.

PRESENTATION OF SILVER KETTLE DRUMS TO THE 1ST LIFE GUARDS — In our June Number, we gave a detailed account of the presentation of a pair of silver kettle-drums to the 2nd Life Guards, and adverted to His Majesty's gracious intention of conferring a similar honour on the 1st Life Guards; this ceremony accordingly took place at Windsor on the 23rd ult. The drums were in every respect similar to those presented on the previous occasion. The ceremony took place in the Little Park, which, with the New Terrace, was crowded with spectators of the first rank and respectability. A guard of honour formed of a troop of the Royal Horse Guards Blue, and of the 1st Regiment of Life Guards, escorted His Majesty to the ground. The King wore a field-marshal's uniform, and was accompanied in his carriage by the Duke of Cumberland, the Princes of Cambridge and Cumberland, and the Prince of Saxe Weimar, each in military uniform. The next carriage which followed His Majesty's, contained the Queen, the Princess Augusta, the Duchess of Gloucester, and the Duchess of Hesse Homberg, and the third contained the Duchess of Cumberland, and Princess Augusta of Cambridge, the Duchess of Saxe Weimar and two little Princes; five others followed, containing the remainder of the royal suite. As the King descended from his carriage, a royal salute was given, and the regiments formed a square, enclosing the royal *cortège*. His Majesty, on presenting the drums to Colonel Lygon, the commanding officer, addressed the Regiment in a very flattering and eloquent speech, of which the following is a summary.

"I need not state to you the occasion upon which we are assembled, which is for the purpose of presenting your regiment with these silver drums. The Royal Horse Guards Blue received a like testimony of regard from the hands of George the Third, and I am aware it was his wish and intention

to have presented similar tokens of respect to both Regiments of Life Guards; but surrounded as he was at that period with the multiplicity of State affairs, and engaged as he was with a sanguinary war, it was deferred, and ultimately forgotten. Circumstances probably of a similar nature were the cause of its escaping George the Fourth.

"I have lately presented the 2nd Regiment of Life Guards a similar pair of kettle-drums to those about to be presented to you, and I feel confident it is equally gratifying to the officers of this highly distinguished corps, to receive this token of their Monarch's approbation, as it is for me to bestow it. At all periods, I believe, the Kings of England had Guards round their persons, although the history of the distant ages are almost silent on the subject; nor have we any certain information respecting this subject till the James's. But to bring it nearer to our own times, we are aware that George the Second had regular mounted Guards for the protection of his person, and it is presumed that those Guards were with him in the field at the battle of Dettingen, gained in favour of the Queen of Hungary; but even of this circumstance very little mention is made in the history of those wars. But we remember what has taken place immediately under our own observation, and proud am I to say, that in every place where you have had an opportunity of showing your courage in the field, it has been with honour and glory to your King and Country.

"To you, Lord Combermere, I most particularly address myself, as commanding this honourable and distinguished regiment. I say they are commanded by an officer of the most distinguished merit in your Lordship's person, one who has served his King and country most successfully and gloriously in every quarter of the world, excepting North America, and but lately returned from an honourable and successful command in the East Indies. I have now but little more to add, confident as I am that should circumstances again render it necessary for this country to be engaged in a foreign war, the same steady

loyalty, courage, and military discipline will be shown again as resplendent as that which in our late wars so dazzled the eyes of all Europe."

Both regiments afterwards re-formed into line, and passed by in slow and quick time; after which their Majesties retired in the same order they came. The ground was kept by a party of the 9th Lancers. The troops were under the immediate command of Lord Edward Somerset. There were a great number of general and other officers on the ground, among whom were Lord Hill, Lord Combermere, Sir James Kempt, Lord Fitz-Roy Somerset, Sir Herbert Taylor, Sir Andrew Barnard, Major-General Wheatley, Colonel Clement Hill, Lords Frederick and Adolphus Fitz-Clarence, &c.

In the evening His Majesty entertained the officers of the regiment in St. George's Hall; upwards of sixty sat down to dinner, which chiefly consisted of the officers who were at the presentation.

COVE NAVAL ESTABLISHMENT.—The Removal of the Naval Establishment from Cove, has called forth a very strong remonstrance from the citizens of Cork. The dissatisfaction which this measure has created there, will be seen by the following Resolutions, adopted at a numerous and highly respectable Meeting lately held in that City, pursuant to Requisition,

His Worship the Mayor in the Chair.

"Resolved—That the removal of the Naval Station from the Cove of Cork, is highly unjust and impolitic towards Ireland.

"Resolved—That in order to counteract in some measure the injurious effects of Absenteeism, justice and sound policy require that a fair proportion of the Public Expenditure should take place in Ireland.

"Resolved—That while we admit, to the fullest extent, the necessity of retrenchment and economy, we cannot but deplore the palpable injustice and neglect which have been shown to Ireland, by the total removal of that part of the Naval Establishment of the United Empire, which has heretofore existed in this country—the more especially, as this injurious measure cannot, in any view of it, contribute either to retrenchment or economy.

"Resolved—That an Absentee Landed

Proprietary, and that a Non-resident Legislature are evils of undoubted magnitude.—That Ireland has suffered, and shall continue to suffer, from them; and that unless remedied, or counteracted by a just and generous course of policy towards Ireland, the inhabitants of this country must demand a revision of the Act of Union.

"Resolved—That a Petition founded on the foregoing Resolutions be prepared and presented to Parliament, and that our Representatives be instructed to present, and support the prayer of the same.

"Resolved—That a Committee of Seven be appointed to prepare the said Petition, consisting of the following gentlemen:—Mr. J. Moore Travers; Mr. Gerard Callaghan, Mr. William Crawford, Mr. William Fagan, Mr. Bartholomew Verling, Mr. Horace Townsend, and Mr. Richard Dowden.

(Signed)

"JOSEPH GARDE, Mayor, Chairman."

The following just and judicious animadversions on this subject, are extracted from the Cork Constitution.

"The impolitic removal of the Flag and Naval Arsenal from Cove, amounts to a virtual exclusion of the sons of the Irish gentry from his Majesty's Navy. The post of a midshipman can only be obtained, according to the existing rules of the naval service, by the recommendation of a captain in command of a vessel of war, or by the recommendation of the Board of Admiralty—and the rule in this respect is so arranged, that the proportion of midshipmen under each of these is specifically settled. If this rule had obtained twenty years ago, and there had been no flag or squadron on the Irish station, there would scarcely be an Irish gentleman in the navy by this time, at least belonging to the South of Ireland. All those opportunities of acquaintanceship, friendship, or other connection, would be wanted, which were so freely afforded by a constant intercourse with the admirals and captains employed on this coast, and by means of which, so many of the Irish youth had an easy and favourable introduction into this important branch of the King's service. If such would have been the case, in the circumstances just mentioned, such is very likely to come to pass hereafter—as all those opportunities have been withdrawn. Where there are no vessels of

war employed, there will be no friendly captain to place a young gentleman on his quarter deck;—and as to a recommendation from the Admiralty,—as far as that may avail,—it can only be procured for the son of an Irish gentleman, through the influence of a Member of Parliament, under the revolutionary reform, notwithstanding all its refinings and purifications. In a little time the relish for the sea service, which has given so many brave and intelligent officers to the navy, will decline altogether—parents will be deprived of this great resource for their children, and this too, when it is even already become a matter of touching anxiety to thousands of fathers, to discover how they may place their sons in a way to earn for themselves honourable bread. For our parts we protest, that we cannot find a shadow of apology for the unfortunate procedure which has produced so great a degree of discontent throughout the province of Munster especially. It is the destruction, idly and absurdly, of one of those ligaments, which strengthened the union of the kingdoms—and which come home to men's minds with infinitely a greater influence, than any inscription whatever upon the rolls of parliament. The Naval Establishment at Cove was always felt to be one of those generous acts, by means of which England showed her cordial desire to let Ireland into a partnership in her renown as well as in her power. There was kindness and there was confidence in it—and there was a common advantage, as well as a common and identified glory in its consequences; for what squadron merely, swept the seas of the finest frigates which cruised against British trade during the last war, with such triumphant effects as the Irish squadron? A harsh and unmeaning procedure like this, which has pulled up by a sudden effort from the very roots the whole of the Naval Establishment, after a prodigious outlay of money upon it, is in the nature of an offence to the feelings of the country—admits of a variety of unfriendly and injurious constructions—inferences of distrust—suppositions of being discarded from the liberal regards of the government—surmises of the want of all affectionate or parental policy, such as would throw hundreds

of artisans upon the world, in a time of great public need and emergency—or close with jealous forecast the avenues and accesses to ambition and renown, which should be open to all generous spirits. The Whigs pique themselves upon their obstinacy; and seem to make no distinction between graciousness in policy, and weakness;—we would exhort them to endeavour to reform themselves in this respect—before they advance farther in a political reform full of perils, and over the future operations of which they will have as little control, as the anxious wishes and desires of hundreds of thousands have over them, and their headlong proceeding in removing the Naval Station from Cove."

ON MEPHITIC AIR IN SHIPS.—*Extract from a letter dated H. M. S. Alfred, 26th May 1831*—"It being necessary to air the magazine before getting in the powder, we placed two stoves in it, which were kept burning for a whole day, then removed, and the magazine shut up. About three days after, upon its being re-opened, and a party of men sent down to work, in a short space of time, three of them were hauled up in a state of insensibility; two wind sails were now put down, and after they had remained some time, the gunner went down with two men, but soon one of them was hauled up senseless, and the gunner himself just reached the upper-deck, when he fell down in the same state. There was some difficulty as to the next proceeding, for we could not try to purify by fire, several cases of rockets being already there; when one of the officers luckily thought of "Fisher's watering-engine"—the suction hose of which was pointed out of the bow-port, and the other into the magazine, nor had it been worked above four hours, when the air was found perfectly pure. The use of this engine, which can be easily worked by two men, is highly serviceable for ventilating ships in any cases where wind-sails cannot be had recourse to with advantage, for instance, when batted down in a gale of wind."

SARDINIA.—The revenue of this island is computed at 2,729,150 francs, (113,720*l.*) of which 38,190*l.* are derived from direct, 71,820*l.* from indirect taxation, and 3710*l.* from crown

lands and the monopoly of salt and tobacco. The clergy levy one-tenth not only upon corn and vineyards, but even on the flocks, throughout the island: this contribution amounts to 40,000*l*. In 1775, the population amounted to 426,375: in 1824, to 412,357; and at the present moment it is estimated at 460,000: though some have carried it as high as 510,000. The nobility amount to 6290, and the clergy and monks to 2892! Cagliari contains 24,000 souls; Sassari 20,000; Tempio 10,000; Iglesias 9000; and Ozieri 8000. Its chief mineral product is lead, the natural store of which is deemed inexhaustible, and the quality of its iron is excellent, though this latter metal is so much neglected, that the island imports to the value of 12,000*l*. annually for its own consumption. Few sardinias or anchovies are now found upon its coast. It contains 346 feudal estates, which are in the hands of forty-two proprietors; and these are independent of thirty-two crown fiefs. Of its soil not more than one-fourth part is cultivated. In the year 1824, its exports amounted to 178,630*l*. and its imports to 202,046*l*. National schools have been established in every parish, and have produced very beneficial effects on the character of the lower classes. They were first set on foot in 1823. In former times the island contained twenty-three episcopal sees; but in the present day, the number is reduced to three archbishopricks and eight bishopricks.

CHANGES IN THE STATIONS OF CORPS SINCE OUR LAST.—1st Life Guards from Hyde Park to Windsor; 2nd Life Guards from Windsor to Regent's Park; Royal Horse Guards from Regent's Park to Hyde Park; 1st Dragoon Guards from Cahir to Dublin; 3rd Dragoon Guards from Bristol to Coleford and to Dorchester; 4th Dragoon Guards from Glasgow to Edinburgh; 6th Dragoon Guards from Limerick to Cahir; 6th Dragoons from Dublin to Longford; 7th Hussars from Newbridge to Birmingham; 8th Hussars from Longford to Manchester; 10th Hussars from Manchester to Dublin; 12th Lancers from Dublin to Newbridge; 14th Light Dragoons from Birmingham to Gloucester; 17th Lancers from Limerick to Cork; Grenadier Guards, 2nd Battalion, King's

Mews; 10th Foot, Reserve Companies, from Tralee to Castlebar; 11th Foot, Reserve Companies, from Gosport to Cowbridge, Merthyr Tidvil; 15th Foot from Quebec to Montreal; 19th Foot from Grenada to St. Vincent; 32nd Foot, Reserve Companies, from Boyle to Tralee; 34th Foot, Reserve Companies, from Clare Castle to Ballinrobe; 43rd Foot from Manchester to Hoydock Lodge (Newton); 60th Foot, 1st Battalion, from Gibraltar to Dublin; 61st Foot, Reserve Companies, from Ballinrobe to Boyle; 66th Foot from Montreal to Kingston; 66th Foot, Reserve Companies, from Castlebar to Clare Castle; 71st Foot, Reserve Companies, from Glasgow to Perth; 73rd Foot, Reserve Companies, from Truro to Devonport; 75th Foot, Reserve Companies, from Chatham to Devonport; 78th Foot, Reserve Companies from Perth to Berwick upon Tweed; 79th Foot from Kingston to York, Upper Canada; 80th Foot from Portsmouth to Macclesfield and to Ashton under Line; 81st Foot, Reserve Companies, from Portsmouth to Gosport; 90th Foot from Gosport to Portsmouth; 93rd Foot, Reserve Companies, from Brecon to Glasgow; 98th Foot, Reserve Companies, from Devonport to Merthyr Tidvil and Brecon.

STAFF CHANGES AND ALTERATIONS—1830.

WINDWARD AND LEEWARD ISLANDS.

Major E. H. Bridgeman, Aide-de-Camp, resigned 24th of June 1830, and succeeded by Lieut. Travers, 19th Foot.

Lieut. T. R. Travers, Assistant-Military-Secretary, and Capt. Crutenden, Brigade-Major; their appointments discontinued from 24th of June 1830.

Capt. Mullen, Fort-Adjutant, appointment ceased on 14th of April, and succeeded by Lieut. Wilson, 93rd Foot.

Charles Hoyland, Apothecary, died 16th November 1830, at Barbadoes.

WESTERN COAST OF AFRICA.

Barrack-Master Christopher Lynch, died of a fever 11th of November 1830.

NEW SOUTH WALES.

Deputy-Inspector of Hospitals, Do-

nald Macleod, embarked for India 15th January 1830.

MALTA.

Edmund Starkel, Apothecary to the Forces, removed from the Staff in March 1830.

JAMAICA.

Henry Barnard Burman, Apothecary to the Forces, died 25th February 1830, having fractured his skull by falling from a gig.

IONIAN ISLANDS.

Capt. T. A. Trant, Sub-Inspector of Ionian Militia, exchanged with Capt. Colthurst 28th Foot, 29th of October 1829.

Lieut.-Colonel George Raitt, struck off the Staff 29th of June 1830.

Lieut.-Colonel Lord Charles Fitzroy, Inspector of Militia, struck off the Staff 24th of June 1830.

Capt. C. F. Firmucane, Sub-Inspector of Militia, struck off the Staff 24th of June 1830.

Capt. H. R. Colthurst, Sub-Inspector of Militia, struck off the Staff 24th of June 1830.

Capt. H. J. French, Deputy-Assist.-Quarter-Master-General, struck off the Staff 24th of June 1830.

Joseph Trigance, Assistant-Staff-Surgeon, embarked for Gibraltar 16th July 1830.

Lieut.-Colonel James Russell, Deputy-Judge-Advocate, resigned 1st of September 1830.

Dr. Thomas Wahab, Assistant-Surgeon to the Forces, promoted to be Surgeon of the 37th Foot, 19th of November 1830.

HONDURAS.

Brigade-Major Charles Schaw, appointment reduced 24th of June 1830.

CEYLON.

John Murtagh, Hospital-Assistant, promoted to Assistant-Surgeon 6th Foot, 29th of August 1830.

John Leethead, Hospital-Assistant, embarked for England 27th of April 1830.

Duncan M'Dearmod, Staff-Surgeon, proceeded to England in March 1830.

GREAT BRITAIN AND IRELAND.

Lieut.-Colonel John Rolt, half-pay, unattached, Connaught District, resigned 16th December 1830.

Assist.-Commis.-Gen. James Gold-

risk, Western District, discontinued on the Staff 24th of March 1830.

Assist.-Commis.-Gen. Thomas Gollston Smith, Western District, discontinued on the Staff 24th of March 1830.

Lieut.-Colonel H. G. Broke, (Munster District,) appointed Dep.-Quar.-Master-General in Nova Scotia.

Brevet Lieut.-Colonel W. Beresford, from the Staff in Nova Scotia, to be Permanent-Assistant-Quarter-Master-General in Ireland, vice Lieut.-Colonel H. G. Broke.

Assist.-Commis.-Gen. Denzal Ibbetson, and Assistant-Storekeeper A. G. Bowdler, Southern District, appointments discontinued 24th of March 1830.

Major-Gen. John Gardiner, appointed Deputy-Adjutant-General to the Forces, 13th December 1830.

Major-Gen. William Thornton, C.B. removed from the Staff of Ireland to that of Great Britain, 18th of August 1830.

Assist.-Quar.-Mast.-Gen. Sir Guy Campbell, appointed Deputy-Quarter-Master-General to the Forces in Ireland, 4th of August 1830.

Assist.-Adjt.-Gen. William George Moore, removed from the Staff of Ireland to that of the Mediterranean, 18th of August 1830.

Lord Wallscourt, Aide-de-Camp, removed from the Staff of Ulster District, by the appointment of Major-Gen. Thornton to the Staff of Great Britain, 18th of August 1830.

Major-Gen. J. C. Dalbiac, and bis Aide-de-Camp Arthur Sullivan, removed from the Staff of Ireland to that of England, 14th August 1830.

Brigade-Major J. C. Smith, Eastern District, Ireland, appointment reduced 24th March 1830.

Assist. Commis. William Cumming, Eastern District, Ireland, appointment reduced 24th March 1830.

Surgeon to the Forces (North Britain) William Munro, removed from the North British District, 5th October 1830.

Lieut.-Gen. the Hon. Sir R. W. O'Callaghan, K. C. B. commanding the Forces, North Britain, succeeded by Major-Gen. Hon. P. Stuart, Sept. 1830.

Lieut. Hon. A. F. Cathcart, Aide-de-Camp to Major-Gen. Hon. P.

Stuart, succeeded by Major P. Edwards.

Brigade-Major, Major John Scott Lindsay, (North Britain) appointment discontinued March 1830.

Staff Surgeon Samuel Hill, M.D. South West District (England) died 31st October 1830.

Lieut.-Colonel T. N. Harris, Major of Brigade, South West District (England) appointed Deputy Adjutant General in Canada, 22nd July 1830.

July 16th. Sailed the Donegal, having effected her repairs, to rejoin the Squadron.

July 21st. Arrived the Alfred, 50, Capt. Robert Mansell, from the squadron under Sir E. Codrington, which she left off the Lizard, to repair her defective rudder-head.

Remain in Hamoaze — Foudroyant, Dublin, Pylades, Arschnee, Beagle, Royalist, Viper, Plover packet, and Echo steamer.

In the Sound — Strathfieldsay convict ship.

In Barn Pool — Alfred.

At the Island — Diligence revenue cutter.

ARRIVALS, SAILINGS, AND INCIDENTS IN THE FLEET.

Portsmouth. — June 30th. Sailed the Briton, 42, Capt. Markland, C.B. for Lisbon.

July 7th. Sailed from Spithead, the fleet under the command of Sir Edward Codrington, consisting of the Caledonia, 120, Capt. E. Curzon (with the flag of the Vice Admiral); Prince Regent, 120, Capt. Deans Dundas (with the flag of Rear-Admiral Parker); Asia, 84, Capt. Hyde Parker; Talavera, 74, Capt. Colby; Donegal, 78, Capt. Dick; Revenge, 78, Capt. Hillyar, C.B.; Wellesley, 74, Capt. Rowley; Alfred, 50, Capt. Maunsell; Barham, 50, Capt. Hugh Pigot; Curaçoa, 26, Capt. Dunn; and Pearl, 20, Commander Broughton; the Volage, Capt. Lord Colchester, sailed on the same day for South America.

July 16th. Sailed the Charybdis, gun-brig, to join the squadron.

July 16th. Arrived the Mersey, 28, Capt. Courtenay, in forty-four days from Tampico, and twenty-seven days from the Havannah.

July 23rd. Arrived the Harpy, cutter, having left the fleet under the command of Sir Edward Codrington the day previous.

At Spithead — Samarang.

In Harbour — Spartiate, Royal George, Winchester, Rattlesnake, Imogene, Mersey, Tweed, Victor, Lightning.

Plymouth. — June 30th, sailed the Pallas, 42, Capt. Manly Dixon, for the West India Station.

July 9th. Sailed the Stag, Capt. Sir Thomas Troubridge, Bart. to join the squadron, from Spithead.

July 12th. The Donegal, 78, Capt. John Dick, came into the Sound to repair her capstan, which had given way.

July 16th. Sailed the Ocean, 80, for the Medway, to be stationed as a Lazaretto.

Foreign. — The Favorite, 18, Commander Harrison, arrived at Sierra Leone on the 25th of April, from the Gambia. The Southampton arrived at Madras from Trincomalee, the 8th of February, and sailed the 12th for the same place. The Success and Crocodile sailed from Madras on a cruise the 21st of February. The Algerine arrived at Buenos Ayres from Rio and Monte Video the 12th of March, and Renard from Falmouth the 30th of March. The Ranger, Rose, and Falcon, sailed from Halifax on a cruise, and Tyrrian for Bermuda, the 5th of June. The Cordelia from Halifax, and Gannet from Bermuda, arrived at Newfoundland, the 6th of June. The Eden arrived at Rio Janeiro from Coquimbo the 17th of April. The Calypso sailed from Rio for Buenos Ayres the 16th of April, and Undaunted for Cape of Good Hope the 17th of April.

The St. Vincent, 120, Capt. Senhouse, with the flag of Vice-Admiral Hon. Sir H. Hotham, arrived at Gibraltar, from Spithead, on the 4th of June. The Belvidera sailed from Malta, on the 23rd of May, for Constantinople.

PRIZE MONEY.

PRIZES ADVERTISED FOR PAYMENT IN THE LONDON GAZETTES, AS REPORTED TO THE TREASURER OF THE NAVY, DOWN TO THE 18TH OF JUNE 1831.

Cambrian, for a Greek Piratical Vessel, capt. 27th June 1827. — Pay 7th April 1831. — Agts. Maude and Co. 14, Great George-street, Westminster.

Ditto, for Quattro Fratelli, capt. 18th March 1824. — Pay 7th July 1831. — Agts. Thomas Stilwell and Sons, 22, Arundel-street, Strand.

Clinker, for Emelia, capt. 31st Oct. 1829. — Pay 25th April 1831. — Agt. William Holmes, 3, Lyon's-inn, Strand.

Ditto, for Altamira, capt. 27th March 1830. — Pay 25th April 1831. — Agt. ditto.

Caroline, for Cheribon, capt. 4th Sept. 1807.—Pay 21st June 1831.—Agt. John Chippendale, 10, John-street, Adelphi.

Freija, for French Privateer, (name unknown,) capt. 18th January 1810.—Pay 21st May 1831.—Agt. Matthew King, 37, Essex-street, Strand.

Hyperion, for Seizures, capt. between 1st Jan. and 31st Dec. 1830.—Pay 24th May 1831.—Agt. Charles Clementson, 8, Adelphi Terrace.

Naiad, for Quattro Fratelli, capt. 18th March, 1824.—Pay 7th July 1831.—Agts. Thomas Stilwell and Sons, 22, Arundel-street, Strand.

Naiad, for Muni, capt. 23rd Feb 1825.—Pay 7th July 1831.—Agts. Thomas Stilwell and Sons, 22, Arundel-street, Strand.

Primrose, for Zepherina, capt. 14th Sept. 1828.—Pay 28th April 1831.—Agts. ditto.

Ditto, for Maria de la Concepcion, capt. 24th March 1830.—Pay 28th April 1831.—Agts. ditto.

Ditto, for Veloz Passagera, capt. 7th Sept. 1830.—Pay 7th July 1831.—Agts. ditto.

Plumper, for Loreto, alias Corunero, capt. 12th May 1830.—Pay 1st June 1831.—Agt. J. Woodhead, 1, James-street, Adelphi.

Ditto, for Minerva de Conceicao, capt. 17th Oct. 1828.—Pay 17th June 1831.—Agts. Evans and Eyton, 7, Northumberland-street, Strand.

Revenge, for Muni, capt. 23rd Feb. 1825.—Pay 7th July 1831.—Agts. T. Stilwell and Sons, 22, Arundel-street, Strand.

Victor, for Emelio, capt. 11th June 1830.—Pay 28th April 1831.—Agt. W. H. B. Barwis, 1, New Boswell-court.

Ditto, for Las Damas Argentinas, capt. 6th Sept. 1828.—Pay 12th July 1831.—Agt. Frederick Goode, 15, Surrey-street, Strand.

The several estimates were then put and agreed to *seriatim*.

Mr. Hume inquired whether the regulation with respect to the filling up of vacancies in the Ordnance Office, by appointing half-pay officers, had been adhered to.

Mr. Tennyson said the regulation was rigidly adhered to.

Navy Estimates. — Sir J. Graham moved that 32,000 men be employed in the sea service of His Majesty for the next thirteen lunar months.

Sir G. Clerk remarked, that though the number of seamen was nominally the same, there was practically a great increase in the naval force of the country this year. Up to February last the Naval Department was charged with the care of the Revenue in the counties of Kent and Sussex, and 2,700 men were employed in that service; but since that time all that duty had been transferred to the Board of Customs.

Sir J. Graham said, that since he had come into office, he had borne off nearly 1000 men more than his predecessors. The *Britannia*, which was a first-rate, and a 74-gun ship, were now on their return from the Mediterranean, and as soon as they arrived at Spithead, their crews would be paid off.

Mr. Leader complained that though so much of the money devoted to naval purposes was raised from Ireland, there was not a single naval station in that country, nor a single farthing expended in it for naval purposes. He knew that the next grant was a million of money for the 20,000 soldiers which were maintained in Ireland. He likewise knew that since the countries had been united, 93,000,000*l.* had been expended on the military service in that country. He wished, however, that the maritime connection between England and Ireland should be greater than it was at present, and he hoped that Government would take that point into consideration before the next time these estimates were submitted to Parliament.

The grant was then agreed to.

On the vote of 49,299*l.* 2*s.* 7*d.* for the contingent expenses of the Navy-office,

Mr. Hume asked the Chancellor of the Exchequer whether he was proceeding on the plan which had been proposed to him for consolidating the Navy-office and the Navy-pay office;

The Chancellor of the Exchequer said that Government was doing all it could to effect that object, but it required time.

The vote was then agreed to.

ABSTRACT OF PARLIAMENTARY PROCEEDINGS CONNECTED WITH THE NAVY AND ARMY.

HOUSE OF COMMONS, JUNE 27.

Ordnance Estimates. — Mr. Tennyson said that he expected no opposition to the grants, they being in fact merely the complement of the year, which had not been provided for, owing to the late dissolution of Parliament.

On the resolution for a grant of 310,000*l.* to defray the charge of timber for the year 1831.

Mr. Hume observed that this was an immense sum for such materials, especially at a time when we were stopping the building of ships. He was aware that it would be defended on the necessity of laying in a good stock of timber; but then it ought not to be forgotten that a store of timber was a perishable store. He would take that opportunity to put a question to his right honourable friend opposite. It had been stated that the fleet which was now assembled at Spithead for nautical evolutions, was likely to be detained there on account of a court-martial. Now he thought that there must be a sufficient number of pendants in the harbour to make a court-martial without taking the officers of this fleet; or if not, he thought that the court-martial might as well wait till the return of that fleet.

Sir J. Graham assured his honourable friend that the fleet was not detained at Spithead for the court-martial, but for other reasons, one of which was, that the fleet was not sufficiently manned.

Mr. Hume asked why should there be any difficulty in manning His Majesty's fleet with able seamen at a time when so many of them were starving at our different ports? He would give his right honourable friend the reason why. The men were adverse to the system of arbitrary punishments without courts-martial, to which they were subjected in His Majesty's fleet. There was no check over the arbitrary spirit of some of our naval commanders, save that of a report of the punishment, which they were ordered to make to the Admiralty. If this system were not altered, we should not be able to man the fleet even in time of peace, without having recourse to impressment, which he would always condemn as an un-English practice.

Sir J. Graham should be sorry to have to discuss so important a subject as the propriety of corporal punishments in the navy on an occasion like the present. There was nothing more incumbent on the Government than to make the King's service as agreeable to the seamen of the country as possible; and he could assure the committee that no effort had been wanting on the part of himself and his colleagues—and, indeed, he was bound in justice to add, on the part of his predecessors in office—to effect that object. The step which the late Lords of the Ad-

miralty took on the last evening which they spent in office was the issuing of a regulation which went to place a more vigilant control over the corporal punishments inflicted by the captains of His Majesty's vessels. It was a regulation well digested and carefully drawn up, and it required that every captain should, in his report of punishments, not only state the punishment inflicted, but also the evidence taken to prove the offence for which it was inflicted. He had carried that regulation one step farther; for he had established a board of six persons at the Admiralty, who reviewed these reports every fortnight. The effect of it was, that every officer felt his responsibility increased, when he knew that his judgment on his men must undergo an instant revision at the Admiralty. The regulations adopted by the Admiralty, he trusted, would have the effect of rendering it unnecessary to resort to impressments, and would also prevent the abuse of the power of inflicting corporal punishments.

Sir G. Clerk expressed his satisfaction at hearing that the First Lord of the Admiralty recognized the principle of impressment, which those who were now at the head of His Majesty's Government had heretofore disputed.

Mr. Hume hoped that Ministers would carefully look to the distribution of seamen as well as to the amount. If the House was to be now called upon to sanction a vote for 20,000 seamen, it was to be expected that they would be kept through during the year, and not dismissed at the expiration of two or three months, just when Government had incurred the expense and been at the trouble of training them for the service.

Mr. Croker entirely dissented from the principle on which the estimates now presented were founded, in so far as they differed from the system adopted hitherto. A worse mode of proceeding than that at present acted on could hardly have been suggested; and he anticipated that many of the right honourable Baronet's arrangements would prove a total failure before the expiration of a single year. There was one circumstance, however, to which he should think it necessary to advert—he alluded to an order issued last year from the Admiralty, setting forth that certain naval officers should not be received at His Majesty's Court. He could not undertake to affirm that this order had occasioned an unpleasant feeling amongst the parties so contemplated, but

he had no doubt that the House at all times would view with considerable jealousy any proceeding which could even by implication have the effect of casting a reflection on the naval service, or any portion of it. The obnoxious order, moreover, had been issued by a military authority, the Secretary to the Lord High Admiral, who had no right whatever to arrogate to himself any such power as that which he professed to exercise.

Sir J. Graham replied, that with respect to the order of the Board of Admiralty, he conceived that the right honourable gentleman had himself answered his own objection, by stating that it was a military order only, and if such, it was of course binding on full pay officers alone, over whom the authority thus exercised clearly existed.

Mr. Croker wished to know whether the right honourable Baronet meant to contend that it was fair to forbid an officer on full-pay from attending at Court, while those on half-pay were to be permitted, even although the Admiralty might have taken cognizance of ill-conduct on the part of officers so excepted. No officer could attend a Levee without permission from the Board of Admiralty conveyed through his commanding officer. Now, the sense of the Board might have been expressed as usual to officers on full-pay through their commanding officer, whereas in the present instance the medium of communication was the Navy List, which was equally addressed to the half-pay in common with the rest of the navy service.

Sir J. Graham said, that the error noticed by the right honourable gentleman, if one at all, which he would not admit, merely related to a point of order, but he was prepared to defend the propriety of the regulation. It had been generally observed, but of course could only bind those over whom the Board had control.

Mr. Croker observed, that the principle at issue was of importance, and he should probably feel it his duty to make a motion on the question, whether the Board of Admiralty had power over half-pay officers; but would be happy first to hear from the right honourable Baronet, whether he was prepared to contend that it had.

Sir J. Graham said, he should state his sentiments on the subject when the right honourable gentleman brought forward his motion. (Laughter.)

Mr. Croker assured the right honourable Baronet, that that escape would not serve, and repeated his question, whether

he would venture to assert that the Admiralty Board had power over half-pay officers.

The vote was then agreed to amidst much laughter.

On the vote for "88,500*l.* to defray the expense of passing convicts to New South Wales for the year 1831,"

Mr. Hume hoped that Government contemplated some arrangement which would diminish the expense of transporting convicts, and also animadverted on the extravagance of supporting a squadron on the coast of Africa, for the purpose of putting down the slave trade, when it was notorious, that at no former period had its operation been more pernicious than at this very moment. It was evident, therefore, that this squadron was inefficacious for the object to which it was destined; but he rather recommended the appointment of a Committee of Inquiry into the Slave-Trade than recommended its withdrawal.

Colonel Sibthorp considered the expense for transporting convicts unwarrantably great, looking to the system hitherto in operation, together with the slender financial resources of the country.

Mr. Croker observed, that the efficiency of our squadron on the coast of Africa was in itself a cause of cruelty to the slaves, inasmuch as difficulties being thrown in the way of the contraband trade, those who carried it on did so with less regard to the comfortable conveyance of the slaves than formerly. He was satisfied, that unless all the maritime powers were to unite for the suppression of the Slave Trade, and allow a right of mutual search, it would be infinitely better for the interests of humanity, were we to withdraw our interference.

Sir J. Graham admitted, that the expense of the establishment for the suppression of the slave trade was enormous, and, still worse, unavailing; for, so far from the trade being checked, he believed it was increasing. He concurred with the right honourable gentleman in saying, that without a mutual right of search, every effort to suppress the slave trade must be unsuccessful. The trade was chiefly carried on under the flag of France: negotiations were now pending with that power on the subject, and he trusted that she would throw no difficulty in the way of the adoption of such a plan as might tend to the effectual suppression of the Slave Trade.

Vote agreed to.

On the vote of "157,576*l.* for half-pay and pensions of medical officers," &c.

Mr. Hume expressed his opinion, that the time was come for putting a stop to promotions in the navy. For a year at least, we ought not to promote a single naval officer, except under peculiar circumstances.

Sir James Graham said, if the plan of one promotion in three vacancies had been adopted at the close of the war, it would have been productive of good effects. Government would strictly adhere to the plan, but it must be admitted that it was necessary not to put a stop to promotion altogether.

Mr. Croker observed, that the great number of officers now in the navy was the result of a protracted war, and twenty years' unparalleled naval exertion. If the system of one promotion in three vacancies had any fault, it was on the side of economy, and sure he was that if we fixed the scale of promotion within narrower limits, the day would come when England would have to rue such shortsighted economy. Promotion was necessary to keep up a proper spirit of emulation in the service.

The other votes passed without any material discussion.

Army Estimates.—Sir H. Parnell laid the Army Estimates on the table, observing, that as the present estimate was (with a single exception) the same as that which had been agreed to by the late House of Commons, it was unnecessary for him to take up any of the time of the committee by entering into its details.

Several votes for pay, &c. of officers and men were agreed to.

Colonel Evans said, if he had a seat in Parliament on the next occasion when those estimates should be discussed, he would object to the expense of the Military Asylum, which he thought excessive.

Mr. O'Connell objected to the materials of which the Yeomanry Corps of Ireland were composed, and declared that they had been originally kept on foot for party purposes. He did not wish to allude to a late melancholy affray, in which the yeomanry were engaged. He repeated, however, that the Irish yeomanry was a party force. An idea existed that the yeomanry force was necessary to put down agitation in Ireland. Never was there a greater mistake, for it was invariably found, that where a yeomanry force was kept up, it was also necessary to keep up a considerable force of the King's regular troops, to keep down the effects of that excitement which the yeomanry corps never failed to produce. If it was necessary to have a military force in any par-

ticular district, let it be of the regular troops, for they did their duty, and nothing more. Indeed, it was a matter of surprise that men of the rank in life of the private soldiers should be found to conduct themselves with so much prudence, discretion, and forbearance, as the regular troops were found to do in Ireland, often under the most trying circumstances. This praise belonged to the regular troops, from the highest to the lowest rank. (Hear, hear.) This was the general feeling in Ireland with respect to them; but a feeling the very reverse prevailed with respect to the yeomanry force. He would move an amendment that the vote be reduced by the sum of 19,000*l.* the amount for the Irish yeomanry force.

Mr. Stanley contended, that under the circumstances in which the yeomanry were called out last Christmas, and as that was a force on which the Government might rely for its general disposition to uphold the laws, whatever might be said of its discretion, it would be most injudicious and unwise economy to get rid of them now, by withdrawing the usual vote. He was, therefore, ready to take the sense of the Committee on the vote.

Mr. O'Connell said he had no wish to embarrass the Government, and if an expectation were held out that this force would not be continued after a time, he would withdraw his amendment.

The Chancellor of the Exchequer admitted that the question was one of great difficulty, as he knew no subject connected with the force in Ireland which had excited more discussion. At the same time, after the services which the yeomanry had rendered when called out last Christmas, when Ireland was in a condition which called for the aid of such a force, he did not see how the usual vote should now be refused. The honourable gentleman had called for a pledge to have the force given up, (Mr. O'Connell said that "an expectation held out was all he required.") He considered that on the part of a Government very like a pledge, and he was not disposed to give it, though he saw no probability of the force being increased. The use of such a force was, he admitted, only a choice of evils; but it was an alternative forced on Government by the circumstances of the country.

Mr. Strickland thought the yeomanry were a necessary force for Ireland, and would support the vote. He hoped that the honourable and learned member would not persevere with his amendment, and he promised to give the honourable and

learned member his support on another occasion, in any motion he might bring forward for the suppression of the yeomanry corps.

Colonel Perceval bore testimony to the tranquil state of the county of Sligo, which he said was in part owing to the establishment of the yeomanry.

Colonel Evans thought that Ireland was not in a state to allow of any part of the police force being withdrawn. He was of opinion that it would be found the best economy to add to the regular forces, and gradually diminish the yeomanry.

Mr. Conolly spoke in praise of the efficiency of the yeomanry and police forces. On several occasions, the mere intimation that the yeomanry were to be called out had the effect of quelling excitement.

After a few more words, Mr. O'Connell withdrew his amendment.

Mr. Hume said, that the House had been occupied with the consideration of the Irish Yeomanry; and he now begged to enter his protest against the continuance of the English Yeomanry. He considered the yeomanry an inefficient and ill-disciplined force; and he thought that England would be in a much better condition if there were embodied in every village a Burgher Guard. He would rather have a body of volunteers, serving without pay, than these gentlemen yeomanry, who must have 170,000*l.* for their services.

The Marquis of Chandos declared, that the services of the yeomanry, which was one of the most constitutional and efficient forces, were given free of expense. (Hear.) The country would not have been in a tranquil state at the present moment, had it not been for the exertions of the yeomanry in the disturbed districts of the country last August. The honourable member for Middlesex had stated that 170,000*l.* was paid to the yeomanry. He knew not where that money went. All he knew was, that the corps which he had the honour to command performed their duty gratuitously.

Mr. Hume said, that when he last called for returns, he found that some of the money went to the noble Marquis and his corps.

Mr. Hunt could not agree with the noble Marquis in thinking that the yeomanry was an efficient and constitutional body. How had it proved its efficiency during the late disturbances in Wales? The House, perhaps, would remember that a body of yeomanry was surrounded by the populace, and that half of them surrendered their arms, and the other half ran away. Nor was this an uncommon

occurrence, for he had seen many similar instances when he was in the yeomanry himself. He thought it was exceedingly impolitic to employ yeomanry to quell disturbances which had broken out in the agricultural districts. If the yeomanry were employed to put down any riots, their property would immediately be marked out for destruction. But it was a mistake to suppose that gentlemen alone constituted the yeomanry. It was composed of butchers, grocers, and apprentices. Apothecaries and surgeons, who required two or three horses for their business, let them out to butcher boys, who served in the yeomanry; and thus escaped the duty. ("No, no.") Honourable gentlemen might cry out "No, no," but his assertions were founded in fact; and he knew a surgeon at Taunton who managed in that way.

The Chancellor of the Exchequer, though he was not in the yeomanry at present, knew the honourable member for Preston's description of the class of persons composing that body to be very incorrect. (Hear.) It was, he was sure, chiefly composed of substantial farmers.

Mr. R. Gordon said, that in looking back to the military debates which had taken place in that House for the last fifty years, it was curious to observe, that the patriots of those days had always argued against a standing army, and in favour of the yeomanry force. It was now, however, discovered that the yeomanry was an unconstitutional body. He expressed his regret that the honourable member for Preston should give circulation to statements which were calculated to prove most mischievous.

Mr. Hunt said he had not made that statement without authority.

Mr. Trevor said that the yeomanry corps were a most efficient force, and were formed of persons who had a stake in the country, and not of apprentices and butchers' boys, as an honourable member insinuated. He thought that the yeomanry had been unjustly libelled by the honourable members for Preston and Middlesex.

Mr. Alderman Thompson said that the privates of the Welsh yeomanry corps, to which the honourable member for Preston had alluded, had certainly not conducted themselves as well as could be desired; but the officers had acted with the greatest courage and intrepidity.

Mr. Lamb protested against the injustice of estimating the character of a whole body of troops from the conduct of a single corps. In Dorsetshire and Wiltshire

the yeomanry had acted with much spirit, and great benefit had resulted from their exertions. He had the most perfect confidence in the yeomanry of England, in case any necessity should arise for their services.

Sir M. W. Ridley protested against the unjustifiable language which some members of that House had directed against the yeomanry corps. Those honourable members might find in their own conduct the justification of Government for raising that force to put down tumults, which arose from the bad advice given by those who, unfortunately, had too much the ear of the poor. (Hear, hear.) He knew that the yeomanry had done good service in the north of England.

Major Petre spoke highly of the good conduct of the yeomanry in Yorkshire.

Mr. Hunt said that, as the honourable member for Newcastle looked at him whilst he spoke, he supposed he meant to say that he (Mr. Hunt) had given the people bad advice. The honourable member should have stated what the advice was. He never gave the people any advice which he was not prepared to justify.

The amendment was then withdrawn, and the original motion was agreed to.

On the question "that 697,000*l.* be granted for the half-pay and military allowance of retired officers,"

Sir H. Hardinge hoped that the Right Hon. Secretary opposite would bring forward some plan for ameliorating the condition of Half-Pay Officers, before the Appropriation Act should be introduced. He would suggest to the Right Hon. Secretary the propriety of allowing these officers to hold Civil Appointments, which, on the recommendation of the Finance Committee, they were now prevented from doing.

Mr. Hume said, that military men, after long service, were inadequate to perform the duties of civil offices. (No.) They could be allowed to hold sinecure situations, and receive the salary as well as any other men in the country. He wished to ask what was the rule as to promotion in the army. He was not aware that there was any other rule but the will of the person who had the patronage.

Sir H. Parnell said there was no fixed rule.

Sir H. Hardinge observed, that there was an extreme difficulty in establishing any rule in the army as to promotion.

Colonel Evans did not apprehend that there would be any difficulty. He thought that the half-pay officers of the army were

not so much attended to as they ought to be. The resolution was then agreed to.

On the vote of 1,335,986*l.* for Chelsea and Kilmainham Hospitals, for the pensioners of the hospitals,

Sir H. Hardinge said he wished to bring to the notice of the Right Hon. Baronet the Secretary at War, the subject of Commutations of Pensions. A practice had been introduced by himself of commuting pensions of soldiers who wished to emigrate to Canada and Van Diemen's Land, and numbers of them had taken advantage of the permission. But he had heard that a number of pensioners who had received their three or four years' pensions on this pretext, had spent the money, and would eventually come on their parishes, so that the object of the plan would be defeated. There were, he also heard, 700 or 800 old soldiers in Ireland, who had been allowed to commute their pensions, and his remark applied peculiarly to them, for they had no parochial relief to fall upon. The Secretary at War should stand between the Government and the old soldier, and take care that no bargain was made prejudicial to the latter, and at the same time take precaution against the abuse of these commutations. Persons of forty-five years of age should not be allowed to commute their pensions. The Right Hon. gentleman observed, that the Pension List had been very large, but from the measures which had been adopted whilst he was in office, in twenty years the list would have been reduced 200,000*l.*

Sir H. Parnell said, that he had followed the principles and regulations adopted by his predecessor, in respect to commutation of pensions. New regulations were, however, in preparation, which would obviate the evil alluded to.

This and the remaining resolutions were also agreed to.

JULY 18.

Brevet.—Mr. Hume (in debate on the expenses of the Coronation), said it was usual, unfortunately for the country, at the celebration of such ceremonies, to issue a considerable brevet commission, which cost not less than 10,000*l.* increase of pay, independent of the various other expenses it had been thought so convenient an opportunity to introduce.* He trusted, how-

* In the same debate we find Mr. Hume's name with Ministers in the majority opposed to the amendment reducing the vote for pensions. How is this reconcilable? is this gentleman's love for economy confined to the Finances of the Red and the Blue?—ED.

ever, that we now lived in better times, and that promotions, with increase of pay, as well as every other idle extravagance heretofore put in practice, would be dispensed with.

The Chancellor of the Exchequer replied, that the subject had been under the consideration of His Majesty's Government.

GENERAL ORDERS, CIRCULARS,
&c.

THE ARMY.

GENERAL ORDERS.

Adjutant-General's Office, Dublin,
30th June 1831.

No. 1.—His Majesty has been pleased to appoint Lieut.-Gen. Sir Richard Hussey Vivian, Bart. and K.C.B. to serve as Lieutenant-General upon the staff of the army in Ireland, from the first of July, for the purpose of succeeding Lieut.-Gen. Sir John Byng in the command of the troops.

No. 2.—In relinquishing the command of the troops in Ireland, Lieut.-Gen. Sir John Byng performs a grateful office to himself, in acknowledging the valuable co-operation and support which he has uniformly received from the general officers, heads of departments, and staff, in the discharge of the duties attached to their respective situations.

He desires, at the same time, to express his sense of the zeal and successful exertions of the commanding officers of corps in the maintenance of discipline, and to add to this his unqualified approbation of the attention and vigilance of officers of all ranks, as well as of the general good conduct of the non-commissioned officers and men.

The Lieutenant-General cannot forget that the troops, more especially at the out-stations, have been frequently called to exercise those qualities on which subordination and good order mainly depend, under circumstances of peculiar difficulty and excitement, and he wishes to mark in the strongest manner, by this public acknowledgment, to Major-Generals Sir George Bingham and Sir Thomas Arbuthnot, his sense, not only of the individual services of those officers, but of the forbearance and exemplary conduct which have characterized the behaviour of all under their orders.

In recording this opinion of the merit

of the troops, the Lieutenant-General feels assured that he is only adding his own to the concurrent approbation of the community at large.

The corps which have been quartered at Dublin having come more immediately under his personal observation, Sir John Byng cannot omit bearing testimony to the very soldierlike and accurate manner in which the duties have been performed, as well as to the order, regularity, and discipline, which have been maintained on every occasion—and he feels himself called on to express particularly to Major-Gen. Sir Edward Blakeney, the high sense he entertains of the unremitting attention and ability which have been the means of ensuring those important objects, and of conferring a character of the highest military efficiency upon the garrison under his charge.

Neither can Sir John Byng refrain in this place to observe, how justly he appreciates the services of the Major-General during his command on a late occasion, at a period of great political irritation, and when the utmost temper and judgment were required for the preservation of the public peace.

If no specific duties under the Lieutenant-General's more immediate cognizance call for any particular remark on the conduct of Major-Gen. Smyth, of the Royal Artillery, and Major-Gen. Pilkington, of the Royal Engineers, in their respective commands—it is no less due to those distinguished officers, as well as to Major-Gen. Macdonnell, commanding in the Ulster district, to say, that every part of their duty has been conducted to the Lieutenant-General's entire satisfaction, and with a zeal and ability equally creditable to themselves and advantageous to the service.

Lieut.-Gen. Sir John Byng takes leave of the troops in Ireland, with his best wishes for their prosperity and honour.

By order, GEORGE D'ASQUILAR,
Deputy-Adjutant-General.

GENERAL AFTER ORDER.

Adjutant-General's Office, Dublin,
30th June 1831.

Since issuing the general order of this day, Lieut.-Gen. Sir John Byng has been honoured with a letter from the General Commanding-in-Chief, desiring him to receive and to communicate to the general officers, officers, and troops, and particularly to those general officers whose exertions have been more immediately re-

quired in the disturbed districts, the expression of his Majesty's gracious approbation.

If any thing could enhance the value of this honour, it will be the knowledge that the Lieutenant-General and the troops in Ireland are indebted for it to a representation made by his Excellency the Lord-Lieutenant, of their high state of discipline, and meritorious services upon every occasion.

By order, **GEORGE D'AGUILAR,**
Deputy-Adjutant-General.

GENERAL ORDER.

Adjutant-General's Office, Dublin,
July 11th.

The admirable state of discipline of the army serving in Ireland, renders any appeal to the principles which govern it wholly unnecessary, but in order to make known his own feelings, Lieut.-Gen Sir Hussey Vivian takes this means of expressing his earnest hope that the forbearance, temper, and discretion, which have uniformly distinguished the conduct of the troops, will continue to be observed by them.

The Lieutenant-General has every reason to hope that no recurrence of those disturbances, which by the active measures of the Government, aided by the zeal and talent of the general officers commanding districts, have hitherto been repressed, will render further interference necessary; but should it unfortunately happen that the troops are at any time called upon to assist the civil power and preserve the peace, the Lieutenant-General confidently expects that they will on no account act, except under the express orders of a magistrate, or in absolute self-defence, or for the protection of persons or property directly endangered. And even under these circumstances, should it unhappily occur, that after every rational means of prevention, force is had recourse to, the Lieutenant-General relies, that while the officers and men faithfully and vigorously discharge their duty to their King and country, they will ever bear in mind the elevated principle inculcated in the orders of that illustrious Prince, under whose command the army obtained its highest honours and perfections, viz.—that "Humanity is the brightest gem in the character of a British soldier."

By command of the Lieutenant-General commanding,
GEORGE D'AGUILAR,
Deputy-Adjutant-General.

COURT-MARTIAL.

A Court-Martial was held on board His Majesty's ship *Caledonia*, at Spithead, on Wednesday the 29th June, for the trial of the Right Hon. Lord William Paget, Captain of His Majesty's ship *Winchester*, on charges preferred against him by John Ayscough, Esq. Captain in His Majesty's Navy, and late Commissioner at Bermuda, viz. for having forcibly excluded him from the cabin on board the *Winchester*, allotted to him by Vice-Admiral Colpoys, Commander-in-Chief on the West India and North American Stations, to accommodate a lady and her child, to whom Lord William Paget had given a passage, and also for disrespectful and unofficer-like conduct to him during the passage to England.

The Court opened about ten o'clock, and was composed of the following Officers:—Vice-Admiral Sir Edward Codrington, G.C.B. President; Rear-Admiral Parker, C.B.; Captains John Dick, David Colby, Samuel Campbell Rowley, William Curry Hillier, C.B. Hugh Pigot, Hyde Parker, John Whitley Deans Dundas, Robert Maunsell, David Dunn, Edward Roper Curzon, C.B. Right Hon. Lord Colchester. Mr. Minchin was engaged for the prisoner, and Mr. Hoskins for the prosecutor.

President—Is there any objection to Sir Charles Paget assisting his nephew? I am sure there cannot be.—None being raised, Sir Charles took his station by the side of Lord William.

The names of the witnesses were then called over, the order for holding the Court-Martial read, and the members of the Court sworn, when the prosecutor delivered the following address:—

Mr. President and Gentlemen of this Honourable Court,—My legal adviser having examined the witnesses on whose testimony I relied, and having intimated to me that there is not sufficient evidence to support the charges against Capt. Lord William Paget, I feel myself bound, as a man of honour, to make a declaration of that fact as early as possible, and to state that I shall not take up the time of this Honourable Court unnecessarily by calling witnesses, nor put his Lordship to the trouble of entering upon his defence. I should not have troubled this Honourable Court to assemble, had I been aware of the circumstance of a material witness not being able to prove a fact on which the whole case rests, and which, on account of his absence, I have only been able to ascertain since I came on board

the Caledonia this morning. This explanation will, I trust, be satisfactory to this Honourable Court."

The Court was then cleared, and on being opened, the Judge Advocate put the following questions to Commissioner Ayscough.

Q.—In your address read to the Court, you say, "I should not have troubled this Honourable Court to assemble, had I been aware of the circumstance of a material witness not being able to prove a fact on which the whole case rests, and which, on account of his absence, I have only been able to ascertain since I came on board the Caledonia this morning." Be pleased to state the name of such witness, and whether he is now on board the Caledonia? A.—Sir William Burnaby, and he is now on board.

Q.—Do you, by your address, mean to abandon the whole of the charges made? A.—Yes.

The President then inquired of Lord William Paget, whether he wished to make any observations upon the address which had been submitted to the Court?

Lord Paget—I wish to make some observations respecting the charges made against me by Commissioner Ayscough, and to adduce such evidence as I might be advised.

President—I cannot see how you can be possibly allowed to call witnesses, there being no prosecution. In coming to a decision, the Court are bound to take into their consideration the peculiar situation in which you are placed.

Upon this the Court was cleared, and agreed that they could not permit any observations to be made, as the charges had been totally abandoned by Commissioner Ayscough. The Court was again opened, and Lord William Paget was informed of the resolution of the Court.

The Court was again cleared, and after nearly an hour's deliberation, re-opened, when the Judge Advocate read the following sentence:—That the charges have not been proved against the Right Hon. Lord William Paget, and the Court do adjudge him to be fully acquitted of all the charges, and every part thereof; and the Court deems it necessary to express their regret, that an officer of Capt. Ayscough's rank and standing in the service should have brought forward charges of a nature so seriously affecting the character of an officer in His Majesty's service, without having, according to his own statement, any evidence to prove the facts.

The President, on delivering Lord William Paget his sword, addressed him as

follows:—"Lord William Paget, I have great pleasure in returning you this sword, and I am authorised by the Court to say, it is their opinion, as it is my own, that your character remains unsullied by the charges which have been brought against you on this occasion; and I may also say, that no man living has a right to attach any blame to you for whatever may have taken place relative to these proceedings."

PROMOTIONS & APPOINTMENTS.

NAVY.

ADMIRALTY-OFFICE, JUNE 30.

His Majesty has been graciously pleased to appoint Capt. Sir Edward Thomas Troubridge, Bart. of the Royal Navy, to be one of His Majesty's Naval Aides-de-Camp, in the room of Capt. Sir Murray Maxwell, Knight, C. B. dec.

PROMOTIONS.

CAPTAINS—Samuel Price, J. N. Gabriel.

COMMANDERS—J. Williams (ret.), H. West, J. Conant (ret.), J. Watson (ret.), J. Mavor (ret.), N. Belden (ret.), K. Fitzgerald (ret.), E. Conant (ret.).

LIEUTENANTS—E. S. Pearce, J. B. West, S. Jones, C. H. Hamilton, James Abbott.

SUBRON—E. B. Rowley.

APPOINTMENTS.

George Tierney, Esq. to be Commissioner of Greenwich Hospital, in the room of the late Sir W. Hope.

CAPTAIN—Price Blackwood to the Imogens.

COMMANDERS—Robert Fitzroy, to the Beagle; H. O. Love, to the Columbine, vice Gabriel, prom.; Thomas Saunders, to the Ordinary at Plymouth, vice Yule, whose term of service has expired; W. G. Agar, to the Arachne; R. Morgan (acting), to the Alligator.

LIEUTENANTS—W. H. Jervis (Flag), to the Prince Regent; W. Griffin, to the Talavera; S. Mercer, to the Blossom; — Servante, to the Athol; — Martyn, to the Dryad; — Ramsey, to the Black Joke; S. Stewart, V. Pickey, H. Lyster, and — Eldridge, to the Imogene; J. C. Wickham and B. J. Sullivan, to the Beagle; G. Beanfoy and J. V. Fletcher, to the Caracœa; J. M. Airy, to the Philomel; A. Reed, to the Kent; J. E. Love, to the Swan; T. Hodges, to the Recruit; A. Smith (h), to the Winchester; J. F. Stirling (Flag), to the St. Vincent; R. Nelsh to the Hyacinth; P. Holman, to the Revenue Cruiser Sprightly, vice Byne, deceased; H. Shomberg, to the Rapid; J. B. Woodthorpe and A. G. Bulman, to the Arachne; S. Barrett, to the Badger; E. C. Erle, to the Stork; B. Shephard, to the Sylvia; W. Lowry, to the Hawke; N. Leworthy, to the Lion; — Roberts, to the

Scout; G. Green, to the Hornet Revenue vessel; R. Cox, William Shallah, C. H. Kempthorne, T. Thompson, W. Wichelo, to the Coast Guard Service.

MASTERS—John Peone, to the Recruit; A. Rea, to the Imogene; — Bailey, to the Viper.

SURGEONS—J. Smyth, to the Imogene; J. Houston, to the Arachne; — Petrie, to the Tweed.

ASSISTANT-SURGEONS—William Pattison, to the Pluto; J. Bankier, M.D. to the Spartiate; S. Browne, to the Prince Regent; T. S. Taylor, to the Conflict; W. Kent, to the Pylades; H. D. R. Henning, to the Asia; J. G. Lyell, to the Imogene; J. Miller, to the Recruit; W. Martin, to the Winchester; A. Coats, to the Arachne; — M'Gowan, to the Royalist; A. Knox, to the Plumper; J. Hamilton, to the Dryad.

PURSERS—T. Shears, to the Imogene; J. Warwick, to the Arachne; W. Rowlett, to the Bangle; J. Sparshott, to the Southampton; G. Smithson, to the Crocodile.

ROYAL MARINES.

PROMOTIONS.

FIRST-LIEUTENANT—W. H. Sturgeon.

SECOND-LIEUTENANT—Mr. Douglas Adam Drrret.

APPOINTMENTS.

SECOND-LIEUTENANT— Appleton, to the Briton.

ARMY.

OFFICE OF ORDNANCE, JUNE 30.

Corps of Rl. Engineers.—First-Lieut. Henry Briscoe, to be Sec.-Capt. vice Covey, dec.; Sec.-Lieut. Edward T. Lloyd, to be First-Lieut. vice Briscoe, prom.

WAR OFFICE, JULY 5.

1st Regt. of Life Gds.—Lieut. Samuel Adlam Baynton, from h. p. unatt. to be Lieut. vice Charles Bethel Codrington, who exc.

6th Regt. Dr. Gds.—Cornet Charles Joseph Trueman, from 9th Light Dra. to be Cornet, vice Lally, who ret.

9th Regt. Light Drs.—Lieut. Arthur Charles Williams, to be Capt. by p. vice Lord Harley, who ret.; Cor. Henry Willoughby Legard, to be Lieut. by p. vice Williams; Cor. D. Lyon Campbell, from 16th Light Dra. to be Cor. vice Trueman, app. to 6th Dr. Gds.; Frederick Gerard, gent. to be Cor. by p. vice Legard.

10th Light Drs.—Lieut. Christopher Hampden Nicholson, to be Capt. by p. vice Kennedy, prom.; Sec.-Lieut. Hon. Henry Alexander Saville, from Rifle Brigade, to be Lieut. by p. vice Nicholson.

18th Light Drs.—Staff-Ass.-Surg. John Clark, M.D. to be Ass.-Surg. vice Thomson, dec.

16th Light Drs.—George William Key, gent. to be Cor. by p. vice Campbell, app. to 9th Light Drs.

1st Regt. Foot.—Staff-Ass.-Surg. Robert Torrie, to be Ass.-Surg. vice Steele, dec.

5th Foot.—Ens. Thomas Connor, to be Lieut. by p. vice May, prom.; Richard Andrew Hyacinth Kirwan, gent. to be Ens. by p. vice Connor.

10th Ditto.—Capt. Robert Ellis, from 46th Foot, to be Capt. vice Bentley, dec.

46th Ditto.—Capt. Phileman Coulman, from h. p. to be Capt. vice Ellis, app. to 16th Foot; Ass. Surg. William Smith, from 41st Foot, to be Ass.-Surg. vice Urquhart, dec.

47th Ditto.—Alexander Mitchell, gent. to be Ens. by p. vice Wyatt, who ret.

51st Ditto.—Lieut.-Col. Charles Syngce, from h. p. unatt. to be Lieut.-Col. vice Samuel Rice, who exc.

57th Ditto.—Lieut. Thomas Frederick Richardson, from h. p. 95th Foot, to be Lieut. vice Samuel Robbins, who exc.

67th Ditto.—Capt. Edward Basil Brooke, to be Major, by p. vice Snow, who ret.; Lieut. Isaac Elton, to be Capt. by p. vice Brooke; Ens. Charles Christopher Davie, to be Lieut. by p. vice Elton; Sydenham Snow, gent. to be Ens. by p. vice Davie.

Rifle Brigade.—Robert Duncan Fergusson, gent. to be Sec.-Lieut. by p. vice Saville, prom. in the 10th Light Dra.

Unattached.—Brev.-Col. Edward Darley, from 58th Foot, to be Lieut.-Col. of Inf. without p.; Brev.-Major Arthur Kennedy, from 10th Light Dra. to be Major of Inf. by p.; Lieut. Charles May, from 5th Foot, to be Capt. of Inf. by p.

Memorandum.—The under-mentioned officers have been allowed to retire from the service. by the sale of unatt. commissions:—

Major Andrew Long, h. p. Permanent Ass.-Qr.-Mas.-Gen.; Capt. Thomas Moses, ret. full pay 9th Rl. Vet. Bat.

JULY 8.

Memorandum.—The h. p. of the under-mentioned Officers has been cancelled from this date inclusive, upon their receiving a commuted allowance for their commissions, viz.—

Lieut. Andrew Counts Cnchrane, h. p. 20th Foot; Ens. Robert Hall Manley, h. p. unatt.; Lieut. John Brockman, h. p. Rifle Brigade; Lieut. George Dawson Flintor, h. p. 7th West India Regt.; Qr.-Mas. William Maillene, h. p. Princess of Wales's, or Durham Fencible Cav.; Lieut. Francis M'Farlane, ret. full pay, late 8th Rl. Vet. Bat.; Ens. Ezekiel Tyd Abbott, h. p. unatt.; Ens. Richard Ponsoby Wehbe, h. p. 88th Foot; Lieut. Meredith Jones, h. p. Rl. Wag. Train; Lieut. William Grattan, h. p. 88th Foot; Surgeon Robert Leaver, h. p. 53rd Foot; Ens. John Ward, h. p. 97th Foot; Lieut. Philip Richardson Peck, h. p. 4th Foot; Capt. Richard Williams, h. p. 36th Foot (temporary rank).

Rl. African Colonial Corps.—Ens. William Smellie, to be Lieut. without p. vice Robert Erskine, placed upon h. p.; Volunteer — Fiodley, to be Ens. vice Smellie.

JULY 12.

3rd Regt. Dr. Gds.—Cornet John Edwards Dyson, to be Lieut. by p. vice Sheppard, who rets. Eyre Evans, gent. to be Ens. by p. vice Dyson;

3rd Regt. Foot Gds.—Capt. Henry Bathurst, from 2nd Foot, to be Lieut. and Capt. vice Douglas, who exc.

9th Regt. Foot.—Lieut. and Capt. Charles Douglas, from 3rd Foot Guards, to be Capt. vice Bathurst, who exc.

14th Foot.—Lieut.-Col. Matthias Everard, from h. p. unatt. to be Lieut.-Col. vice Thornhill, who rets.

20th Ditto.—Lieut. John Maclean, to be Capt. without p. vice Story, dec.; Ens. Edmund Dalgety, to be Lieut. vice Maclean; Ens. William Frith, to be Lieut. by p. vice Waddell, who rets.; Gent. Cadet James Gates, from Rl. Mil. Coll. to be Ens. vice Dalgety; Henry Windham, gent. to be Ens. by p. vice Frith.

27th Ditto.—Ens. Edward O'Grady, to be Lieut. by p. vice Hay, prom.; Henry D. Cholmeley, gent. to be Ens. by p. vice O'Grady.

38th Ditto.—Ens. William Samuel Edwards, to be Lieut. by p. vice Willes, who rets.

44th Ditto.—Staff Assist.-Surg. Arch. M'Isaac, from h. p. to be Assist.-Surg. vice Browne, app. to 3rd Foot.

51st Ditto.—Major James Campbell, to be Lieut.-Col. by p. vice Synge, who rets.; Capt. William Henry Elliott, to be Major, by p. vice Campbell.

60th Ditto.—Capt. Thomas Richard Plumbé Tempest, vice Grey, prom.; Capt. James Badham Thornhill, from 66th Foot, vice Chichester, prom. to be Major, by p.; Lieut. David Fitzgerald, vice Tempest, to be Capt. by p.; Sec.-Lieut. Robert Atkins, vice Fitzgerald, to be Lieut. by p.; Gent. Cadet John Morris, from Rl. Mil. Coll. vice Atkins, to be Sec.-Lieut. by p.

65th Ditto.—Capt. John Hawson Stepney, from h. p. to be Capt. vice Thornton, prom. in 60th Foot.

69th Ditto.—Robert Sutton, gent. to be Ens. by p. vice Kinchant, prom.

73rd Ditto.—Capt. Robert Anstruther, to be Major, by p. vice Drewe, prom.; Lieut. Richard Watkins Bamford, to be Capt. by p. vice Anstruther.

98th Ditto.—Robert Pamplin Wallis, gent. to be Ens. by p. vice Bayntun, who rets.

Unattached.—To be Lieut.-Colonels of Inf. by p.—Major Richard Drewe, from 73rd Foot, Major Charles Chichester, from 60th Foot, Major Hon. Charles Grey, from 60th Foot.

To be Capt. of Inf. without p.—Lieut. Dickens Mark Haslewood, from 14th Foot, Lieut. Henry Mansell, from 14th Foot.

To be Capt. of Inf. by p.—Lieut. Lewis James Hay, from 27th Foot.

To be Lieut. of Inf. by p.—Ens. Richard Henry Kinchant, from 60th Foot.

Memoranda.—Cornet Johnson's commission, in the 7th Dragoon Guards, has been antedated to 26th Feb. 1830, that being the period he was appointed Riding-master to that corps.

Cornet Henry Phillips' commission, in the 7th Light Dragoons, has been antedated to 25th March 1829, that being the period he was app. Riding-master to that regiment.

The date of Lieut. Arch. Neil Campbell's promotion, in the 92nd Foot, has been antedated to 8th April 1831.

The undermentioned officers have been allowed to retire from the service, by the sale of unattached commissions, viz.—

Lieut. Col. John William O'Donoghue, h. p. unatt.; Major-Gen. James Patrick Murray; Lieut. Thomas Wright, h. p. 14th Foot.

JULY 19.

2nd Regt. Life Gds.—Alex. Champion Street field, Gent. to be Cornet and Sub-Lieut. by p. vice Martyn, prom.

10th Regt. Light Dra.—Cornet John Rowley, to be Lieut. by p. vice Heneage, who ret.; Edward David Crosier Hilliard, Gent. to be Cornet by p. vice Rowley.

11th Ditto.—John Rose Holden Rose, Gent. to be Cornet by p. vice Oakley, who ret.

1st or Gren. Regt. Foot Gds.—Fred. Wm. Hamilton, Esq. (Page of Honour to the King), to be Ens. and Lieut. without p.; John Parkinson, Gent. to be Solicitor, vice Humphries, dec.

4th Regt. Foot.—Lieut. Wm. Hundy Campbell, to be Capt. by p. vice Lardy, prom.; Ens. Wm. O'Grady Haley, to be Lieut. by p. vice Campbell; John Darcus Territt, Gent. to be Ens. by p. vice Haley.

31st Ditto.—Lieut. Hon. Robert Preston, from the h. p. 6th Regt. to be Lieut. vice Valentine, whose app. has not taken place.

35th Ditto.—Staff Assist.-Surg. Andrew Halliday Hall, to be Assist.-Surg. vice Humfrey, app. to the 95th Regt.

38th Ditto.—John Dwyer, Gent. to be Ens. by p. vice Edwards, prom.

41st Ditto.—Assist.-Surg. Wm. Dowell Fry, from the h. p. 47th Regt. to be Assist.-Surg. vice Smith, app. to the 46th Regt.

73rd Ditto.—Ens. James Skene, to be Lieut. by p. vice Bamford, prom.; Maurice Charles O'Connell, Gent. to be Ens. by p. vice Skene.

79th Ditto.—Ens. John Stewart Smyth, to be Lieut. by p. vice Inham, whose prom. has not taken place.

98th Ditto.—Charles Granet, Gent. to be Ens. by p. vice Mackenzie, prom.

Rifle Brigade.—Capt. John Alex. Henderson, from the h. p. to be Capt. vice John Allen Ridgway, who exc. rec. the dif.

Unattached.—To be Major of Inf. by p. Capt. Christian Fred. Lardy, from the 4th Regt.; to be Lieut. of Inf. by p. Ens. Roderick Mackenzie, from the 98th Regt.

Hospital Staff.—Assist.-Surg. Alex. Callander, from the 91st Regt. to be Assist.-Staff-Surg. vice Hall, app. to the 35th Regt.

Memoranda.—The undermentioned officers have been allowed to retire from the service, by the sale of unattached commissions, viz.—

Major Haddon Smith, h. p. unatt.; Lieut. Geo. Taylor Latham, h. p. 27th Foot.

ANNALS OF THE BRITISH FLEET.

1806.* War with France, Holland, Spain, and Prussia.†	Lords Commissioners of the Admiralty.	Principal Commanders-in-Chief.
	First Lord—Lord Howick‡ (late Mr. Grey, and now Earl Grey.) Right Hon. Thomas Grenville, Lord Barham. James Gambler. Sir Philip Stephens, Bart. Philip Patton. William Dickinson, Jun. Sir Evan Nepean. Lord Garlies. John Markham, from 11th Jan. Sir Charles Maurice Pole, Bart. from 11th Jan. vice Patton. Sir Harry Burrard Neale, Bart. from 11th Jan. vice Sir E. Nepean. Lord William Russell, from 11th Jan. vice Dickinson. Lord Kenington, from 11th Jan. vice Lord Garlies. Thomas Freemantle, vice Sir Phillip Stephens,§ Bart. William Frankland, vice Sir C. M. Pole, Bart.	Channel.—Admiral Earl St. Vin- cent. Portsmouth.—Adm. Montagu. Plymouth.—Vice-Admiral Young. Cork.—Adm. Lord Gardner. North Sea and } Adm. Lord Keith. Downs. } Cape of Good } Rear-Admiral Sir Hope. } Thos. Troubridge. Halifax.—Vice Admiral Hon. George Berkeley. East Indies.—{ Rear-Admiral Sir E. Pellew, and Rear-Admiral Sir Thos. Troubridge. Jamaica.—Vice-Admiral Dacres. Mediterranean.—{ Vice-Admiral Lord Colling- wood.

DISTRIBUTION OF THE BRITISH NAVAL FORCE IN EACH MONTH OF 1806.¶

Stations.	Number of Ships.											
	January.	February.	March.	April.	May.	June.	July.	August.	September.	October.	November.	December.
In Port and fitting	No. 169	No. 193	No. 165	No. 150	No. 121	No. 157	No. 144	No. 160	No. 155	No. 141	No. 174	No. 176
In the English and Irish Channels	118	99	124	128	147	143	142	134	141	160	130	141
In the Downs and North Sea	167	139	127	132	136	143	141	146	150	137	148	154
West Indies and on the passage	49	47	47	65	53	60	57	52	44	47	43	45
On the Jamaica station	41	37	38	42	48	41	41	47	43	32	37	35
In America and at Newfoundland	20	19	18	16	25	25	28	28	30	33	27	29
At the Cape of Good Hope	—	—	—	9	12	12	10	9	12	11	23	18
East Indies, and on the passage	41	30	39	42	43	39	40	42	30	38	35	39
Coast of Africa	5	4	4	4	2	3	3	3	3	2	4	3
Spain, Portugal, and Gibraltar	47	36	44	36	30	33	33	34	30	41	38	34
Mediterranean and on the passage	32	25	30	33	33	30	30	33	33	30	32	34
Hospital and Prison Ships	19	—	—	—	—	—	—	—	—	—	—	—
With Sealed Orders	7	7	7	—	—	—	—	—	—	—	—	—
In pursuit of a French squadron	—	7	30	17	25	16	24	30	29	21	11	—
Harbour Ships, &c. in Commission	—	22	20	22	21	20	22	22	23	26	27	29
Intended for Foreign Service	—	26	9	5	3	—	—	—	—	—	—	—
In return from ditto	—	6	4	4	4	6	2	—	—	4	2	—
Guard Ships	12	14	15	15	14	13	13	16	12	13	9	13
Total Ships in Commission	727	719	721	720	723	742	780	753	745	736	747	773
Receiving Ships	10	17	17	19	15	16	17	17	21	16	11	15
Serviceable and repairing for Service	22	17	51	52	54	50	50	47	40	53	59	59
In Ordinary	105	79	96	93	99	96	96	93	96	96	100	110
Building	75	86	83	86	101	88	82	93	84	116	128	132
Grand Total	943	958	968	972	992	992	975	1003	997	1017	1051	1079

* For the year 1805, see p. 131 of this volume.

† Hostilities with Prussia ceased in October, after the battle of Auerstadt.

‡ Appointed on the death of Mr. Fox to the Foreign Office, and succeeded at the Admiralty by Mr. Grenville.

§ Resigned at the age of 83, after being sixty-one years in the Navy and Admiralty Offices. He received a pension of £1500 per annum, and was the first instance of a Lord of the Admiralty being allowed a pension upon retiring from office.

¶ Exclusive of the hired armed vessels chiefly employed in protecting the coasting trade.

STATE OF THE ROYAL NAVY IN JANUARY 1896.

Rates or Classes.	Number of guns in each ship, viz.		* Establishment of 1792, see p. 32 † of Admiralty Orders of Nov. 19th 1794, including carronades on the quarter deck, poop, and forecaste.	Number of Ships in			Grand Total, viz.			Burthen of the ships in				
				Commission.	Ordinary.	Building or ordered to be built.	British and Foreign built ships.	Foreign built ships.	British built ships.	Commission.	Ordinary.	Building or ordered to be built.	Total.	
														No.
Three Deckers.	1st	120	116	12 & 18 pound.	1	—	2	3	—	3	2,508	—	5,233	7,741
		112	108	ditto	3	—	3	3	2	7	7,206	—	—	7,206
		100	106	ditto	2	2	3	7	—	7	4,266	4,448	6,593	15,307
	2nd	98	106	ditto	14	1	1	16	—	16	27,988	21	2,278	32,387
		80	88	24 pounder.	7	4	—	11	9	2	14,995	8,764	—	23,759
		74	82	18 pound. large	11	—	3	14	3	11	20,991	—	5,749	26,740
	3rd	74	82	18 pound. middl.	15	5	2	22	9	13	28,121	9,293	3,741	41,055
		74	82	small	13	5	14	32	5	27	22,633	8,694	24,213	55,530
		74	82	flush	27	16	1	44	3	41	44,011	25,895	1,674	71,580
	4th	64	72	common or quarter-decked.	28	8	—	36	12	24	38,679	11,103	—	49,782
		60	60	flush	—	—	2	2	1	1	—	—	—	2,511
		56	62	flush	1	1	—	2	—	2	1,256	1,426	—	2,682
Two Deckers.	5th	44	52	flush	9	0	—	18	3	15	9,414	9,520	—	18,934
		44	52	Frigate	1	1	—	2	—	2	882	892	—	1,774
		44	40	18 & 24 pound.	5	1	—	6	2	4	6,947	1,357	—	8,304
	6th	38	46	large	4	—	—	4	—	4	4,751	—	—	4,751
		38	46	small	17	5	8	30	15	15	18,578	5,475	8,705	32,758
		36	44	18 pound. large	16	3	1	20	4	16	15,934	8,024	991	19,949
	6th	36	44	small	8	3	—	11	8	3	8,285	3,039	—	11,324
		36	36	12 pounder	15	3	6	24	—	24	13,789	2,742	5,577	22,108
		32	38	18 pound. large	11	8	—	19	18	1	10,138	7,448	—	17,586
	6th	32	38	small	5	—	3	8	—	8	4,542	—	2,749	7,291
		32	38	12 pound. large	6	—	—	6	—	6	4,733	—	—	4,733
		32	38	small	8	3	—	0	6	3	4,013	2,340	—	7,253
6th	28	32	Gun-boat ship	23	13	—	33	1	32	15,051	6,019	—	22,632	
	28	32	flush	11	2	—	13	2	11	6,799	1,192	—	7,991	
	24	32	Quarter-decked	6	1	—	7	3	4	3,245	528	—	3,773	
6th	20	28	flush	2	—	12	14	2	12	1,130	—	6,412	7,542	
	20	28	flush	5	2	—	7	3	4	2,232	940	—	3,172	
	20	28	flush	4	3	—	7	7	—	2,194	1,598	—	3,732	
Sloops from 14 to 18 guns . . .				130	18	52	200	32	168	45,886	6,035	20,462	72,383	
Bombs of 8 guns and 2 mortars . . .				15	3	—	18	—	18	5,231	1,057	—	6,288	
Fire-ships of 14 guns each . . .				1	1	—	2	—	2	425	243	—	668	
Gun Brigs from 10 to 14 guns . . .				101	1	3	105	0	0	18,184	169	540	18,893	
Cutters from 4 to 14 guns . . .				59	1	18	78	26	52	6,933	152	1,355	8,440	
Troop ships, store ships, &c. . .				52	34	1	87	21	66	34,806	33,895	199	68,900	
Grand total, viz.				634	154	131	920	206	714	459,105	161,324	97,033	717,462	
Ships of the line from 60 to 120 guns . . .				121	43	26	190	44	146	211,398	72,819	49,381	333,598	
Ships of 56 guns and under . . .				513	111	105	730	162	562	247,707	88,505	47,652	383,864	

ESTIMATES OF THE ROYAL NAVY.

120,000 men including 20,000 Marines

Wages	£2,886,000	0	0
Victualling	2,064,000	0	0
Wear and tear of ships	4,680,000	0	0
Ordinance for sea service	390,000	0	0
Carried forward	£10,920,000	0	0

Brought forward	£10,920,000	0	0
Additional pay	193,158	2	4
For such measures as the exigency of affairs may require for Great Britain	2,400,000	0	0
For like purposes for Ireland	600,000	0	0
Ordinary, including half-pay to sea and marine officers	1,045,353	12	11
Building and repairing ships of war	1,980,830	0	0
Line of transports	1,250,000	0	0
For defraying the charge of prisoners of war in health	400,000	0	0
Ditto of sick prisoners of war	45,000	0	0
For hospitals for seamen	30,000	0	0
Total	£18,864,341	15	3

ACTIONS, AND OCCURENCES, AND CHRONOLOGICAL EVENTS OF THE
BRITISH NAVY.

January 2. The boats of the Malabar, 50, R. Hall, and Wolfe sloop, 18, G. C. McKenzie, covered by the fire of the latter, brought out from Port Azarardes in Cuba, two privateer schooners, the Regulateur and Napoleon; the former mounting 5 guns with 80 men, the latter 3 guns with 66 men. The British had two killed and four wounded. The enemy's loss could not be ascertained, as they escaped on shore in their boats. The Regulateur sunk soon after being taken possession of. Manly, gun-brig, Lieut. M. White, 12, B. 1804, ran on shore near Rysum on the Ems, in East Friesland, and there seized by the enemy, in violation of the neutrality of that river, her commander being previously captured.—3. The Cape of Good Hope* retaken from the Dutch by Gen. Baird and Sir Home Popham.—6. Favorite, sloop, John Davie, 18, B. 1794, taken by a French squadron off Cape de Verd Islands.—7. Two Spanish national brigs, one of 20 guns and 180 men, the other of 12 guns and 75 men, and a schooner of 8 guns, being in Campeachy Bay, Capt. C. Dashwood, of the Franchise, 38, sent three boats to attempt to cut them out, under the orders of Lieut. J. Fleming, assisted by Lieut. P. J. Douglas, Lieut. Mends of the marines, and Messrs. Daly, Lamb, Chalmers, and Hamilton, midshipmen. The moon rising, gave the enemy warning of their approach, and they, with seven gun-boats, slipped their cables, and opened a heavy fire on the boats. Lieut. Fleming immediately laid the nearest brig, the Raposo, on board, and was so quickly supported by the other two boats, that they carried her in ten minutes. The remainder of the flotilla followed at some distance; but their fire was so smartly returned from the brig and boats, that they soon retired to their former position. The Dutch had seven wounded.—9. The public funeral of the gallant Admiral Lord Nelson.—9. Bato (Dutch) 68, burned in Table Bay by the Dutch, to the water's edge.—14. Capt. G. Youngbusband, || Henreux 24, (Leeward Island Station) captured the Spanish letter of marque, Amelia, 8 guns and 40 men, having on board a valuable cargo.—15. Lieut. Baker, of the Grenada brig, had a smart action with the Princess Murat, French letter of marque, of 8 guns, several swivels, and 52 men. It lasted four hours and thirty minutes, when having three men killed and seven wounded, she surrendered. Papillon sloop, (F.) W. Woolesey, 10, taken 1803; foundered on passage from Jamaica station with all the crew. Berbice, schooner, Lieut. J. G. Gooding, 6, B. 1804; sunk at Demerara, crew saved.—25. The Magicienne, 32, A Mackenzie, in company with the Penguin sloop, after a chase of twelve hours, captured in the Mona passage, El Carmen, Spanish packet, pierced for 14 guns, but only two

* See Military Annals. Major-Gen. Baird, in his dispatch, highly eulogised the cordial, able, and zealous co-operation of Sir Home Popham and his officers, and the gallantry of the British seamen. Such of the ships as could be spared coasted the enemy's shore, throwing shot among his troops and people, and contributing to keep him ignorant of the actual place of disembarkation. A very spirited effort was made by the marines of the fleet, commanded by Capt. G. Byng, and a party of seamen from the Diadem, under the Commodore's immediate command, to occupy a position in Reit Valley, and to co-operate with the army. The ships which assisted in the reduction of this settlement were, the Diadem, 64, Commander Sir H. Popham, Capt. Downman; Belliqueux, 64, G. Byng; Raisable, 64, J. Rowley; Leda, 38, R. Honeyman; sloops, brigs, &c.

† See Note to 28th June, capture of Buenos Ayres.

‡ The Raposo was pierced for 16, but had only 12 guns mounted, exclusive of coborns, swivels, and small arms, with 75 men, five of whom were killed, and the commanding officer and 25 men wounded.

§ The following inscription was on the coffin:—"Depositum.—The most noble Lord Horatio Nelson, Viscount and Baron Nelson of the Nile, and of Burnham Thorpe in the county of Norfolk, Baron Nelson of the Nile and of Hilborough in the said county; Knight of the most honourable Order of the Bath; Vice-Admiral of the White Squadron of the Fleet, and Commander-in-Chief of His Majesty's ships and vessels in the Mediterranean; also Duke of Bronte in Sicily; Knight Grand Cross of the Sicilian Order of St. Ferdinand and of Merit; Member of the Ottoman Order of the Crescent; and Knight Grand Commander of the Crescent; and Knight Grand Commander of the Order of St. Joachim. Born Sept. 29th 1758; after a series of transcendent and heroic services, this gallant Admiral fell gloriously in the moment of a brilliant and decisive victory over the combined fleets of France and Spain off Cape Trafalgar on the 21st of October 1805."

|| See also Feb. 16th and 17th, March 8th and 29th.

mounted, and 13 men. El Bengador, Spanish, 1 gun, 28 men, taken by the Pomone, 38, W. G. Lobb, off Lisbon.—28. Le Voltigeur, French lugger, 14 guns, 66 men, taken by the Growler brig, 14, Lieut. T. Nesbitt, off Brest. Le Sorcier, French lugger, 14 guns, 60 men, taken by the Attack brig, 14, Lieut. T. Swaine, off Brest.—29. L'Impromptu, French lugger, 15 guns, 50 men, taken by the Bruiser brig, 14, Lieut. T. Smyth, off Falkstone.—31. Petite Fonfranc, French, 1 gun, taken by the Wolverine brig, 18, J. Smyth, off Barbadoes.

February 2. Seaforth, Lieut. George Steele, (2) 16, B. 1805, upset in a squall on the Leeward Island Station, two of the crew saved. Two Spanish gun-boats, each 2, taken by the Felicity privateer, 12, M. Novella (Mediterranean). Prince Murat, French ship, 18 guns, 127 men, taken by the Druid, 32, P. V. E. Broke.—5. Battledore, Spanish, 6 guns, 47 men, taken by the Curieux sloop, 16, J. Johnstone, off Lisbon.—6. Vice-Admiral Sir J. T. Duckworth discovered a French squadron of five sail of the line, two frigates, and one corvette, at anchor in the bay of St. Domingo, which, with the squadron under his command, consisting of seven sail of the line, two frigates, and two sloops, he immediately attacked. The action commenced a little after ten, by the Superb closing upon the bow of the Alexandre, the leading French ship, who, receiving three broadsides, sheered off. The signal was then made for closer action, when the Admiral was attacked in the Imperial, of 120 guns (formerly Le Vengeur), the fire of which had been heavy on the Northumberland, bearing the Hon. Rear-Admiral Cochrane's flag. By this time the movement of the Alexandre (formerly L'Indivisible) had thrown her among the lee division, which Rear-Admiral Louis happily availed himself of. The action became general, and continued with great severity till half-past eleven, when the French Admiral, much shattered and completely beaten, hauled direct for the land, and not being a mile off, at twenty minutes before noon ran on shore, his foremast then only standing, which fell directly on her striking, at which time the Superb being only in seventeen fathoms water, was forced to haul off to avoid the same fate; but not long after, the Diomedé, of 84 guns, pushed on shore near his admiral, when all his masts went. About fifty minutes after eleven the firing ceased, leaving in possession of the British, Le Brave, 74, bearing a Commodore's pendant, L'Alexandre, 84, and Le Jopetre, 74.—“I think it a duty I owe to character and my country to add, from the information of Sir Edward Berry, after she had struck, and the Agamemnon desisted from firing into her, from the captain taking off his hat, and making every token of surrender; and Capt. Dunn assures me both ensign and pendant were down; to comment on which I leave to the world.”—DISPATCH. Public thanks were given to the officers and seamen for their conduct in this decisive action.* The British squadron consisted of the Superb, 74, Vice-Admiral Sir J. T. Duckworth, Capt. Keats, 6 killed, 56 wounded; Northumberland, 74, Rear-Admiral Hon. A. Cochrane, Capt. J. Morrison, 21 killed, 79 wounded; Spencer, 74, Hon. R. Stopford, 18 killed, 50 wounded; Canopus, 80, Rear-Admiral Louis, 8 killed, 22 wounded; Donegal, 74, P. Malcolm, 12 killed, 33 wounded; Atlas, 74, Samuel Pym, 8 killed, 11 wounded; Agamemnon, 64, Sir E. Berry, 1 killed, 13 wounded; Acasta, 40, R. D. Dunn; Magicienne, 32, A. McKenzie; Kingfisher (sloop), and Epervier (sloop).†—7. Racine, French, 4 guns, taken by the Forward gun brig, 14, Lieut. Daniel Shiels, in the Channel.—11. Pecullo, No. 4, Spanish gun-brig, 5, taken by the Envy privateer, off Cape de Gatt.—15. Princess Murat, French schooner, letter of marque, 3 guns, 82 men, taken by the Grenada brig, 10 guns, John Barker, off Barbadoes.—16. Capt. G. Youngusband, Heureux, 24, (Leeward Island Station) captured La Bellone, French privateer, 14 guns, and 117 men. She had on board 8000 dollars, being her owners share of a prize they had carried into Cazenne.—17. The same ship captured, after eight hours' chase, La Bocune, French privateer schooner, 3 guns, and 60 men.—21. Rollo, French brig, taken at the Cape of Good Hope, by the squadron under Sir Home Popham.—23. Unique, schooner, Lieut. G. R. Brand, 8, taken on the Leeward Island Station by a French privateer of double her force, after a resistance characteristic of the energy of British seamen.—27. Capt. G. Mundy, Hydra, 38, in chasing four frigates and a brig that had escaped from Cadiz, succeeded in cutting off and capturing the brig Le Furet, 18 guns, after firing one broadside at the Hydra.

March 1. Josephia, French, 3 guns, 37 men, taken by the private ship Felicity, M. Novella.—4. Voltaire, 46, French, surrendered, without firing a shot, to the Diadem, 64, Sir Home Popham, Capt. W. King, after having been chased into Table Bay, Cape of Good Hope, by Capt. R. Donelly, commander of the Narcissus, 32, and Capt. J. Rowley, of the Reasonable, 74.—4. Rollo, French, 16 guns, taken by Sir Home Popham's squadron. Agnes, lugger, 8, (hired) lost off the Texel. Fate of the crew unknown.—8. Capt. Handfield, volunteer on board the Egyptienne, 40, Capt. Paget, as first Lieutenant, during her cruise, not having received an official communication of his promotion previous to her sailing, was sent with the boats of the Egyptienne to cut out a French privateer L'Alcide,‡ in the harbour of Muros, which he accomplished in a very gallant manner, being ably supported by Lieuts. Collyer and Garthwaite and crew, though she was moored close to the beach, and under the

* For this victory Admiral Duckworth received the thanks of Parliament, and of the Corporation of London, with the freedom of the city, and a sword valued at 200 guineas. The Patriotic Fund at Lloyd's presented him with a vase valued at £400.

† From this statement it will be seen that the British squadron consisted of eleven ships, of which seven of the line, with 514 guns, had 74 killed and 264 wounded; and that the French squadron was composed of eight ships, of which five of the line had 436 guns; the three captured ships had 760 killed and wounded, and it is supposed the two which escaped, and were wrecked and burnt, suffered in proportion to the others; the two frigates and corvette escaped.

‡ A frigate-built ship, pierced for 34 guns, and had when lost at sea 240 men.

protection of two batteries, which kept up an incessant fire, till she was towed clear out of their range. The *Heureux*, 24, G. Younghusband, (Leeward Island Station) captured the French privateer *Le Huron*, 18 guns, and 130 men. Upon the *Heureux* getting alongside *Le Huron*, she opened a smart fire but was soon silenced; her Captain, second Lieutenant, and two men were killed, and seven wounded.—12. *San Cristo del Paldn*, Spanish, 14 guns, 67 men, taken by the *Thunderer*, 74, John Stockham, off Cadix.—12. Capt. F. A. Collier, of the *Wolverine* brig, 18, (Leeward Island Station), captured the French national schooner *La Tremouse*, 3 guns, and 53 men.—13. The squadron under the command of Vice-Admiral Sir J. B. Warren, Capt. J. C. White, of the *Poudroyant*, 80, after an action commenced by the *London*, 98, Sir H. B. Neale, and supported by the *Amazon*, 38, W. Parker, captured the *Marengo*, 80, Admiral Lincoln, and 750 men; and the *Belle Poule* frigate, 40, and 320 men. The British had 14 killed and 30 wounded, and the French 65 killed and 80 wounded.*—17. *Santa Clara*, Spanish schooner, 1 gun, 28 men, taken by the *Pique*, 36, C. H. B. Ross,† Jamaica Station.—24. *La Lutine*, French corvette, 16, since *Hawke*, taken by the *Carysfort*, 28, K. M'Kenzie, and *Agamemnon*, 64, Sir E. Berry, by the former of whom she was chased for 36 hours, and surrendered two hours after the junction of the *Agamemnon* (Leeward Island Station).—26. Capt. Ross, of the *Pique*, 40, between St. Domingo and Curaçoa, fell in with two French men-of-war-brigs, the *Phæton* and *Voltigeur*, 16 guns, and 120 men each, when, after a most destructive fire, continued for about twenty minutes, the *Pique* being placed across the hawse of the *Commodore*, she was directly boarded by Lieuts. Ward and Baker, and Mr. Thompson, and every inch of her decks was most obstinately defended, and the slaughter on both sides dreadful; but in about four minutes the colours were hauled down. The other brig struck after a few more broadsides. It was impossible for two vessels to be more obstinately defended, every thing being cut to pieces, and nearly one half of their crews killed or wounded. The *Pique* had 9 killed and 14 wounded.—28. The *Niche*, J. W. Loring, at ten a.m. chased three French frigates and a brig, standing out of L'Orient, and at ten p.m. came up with and took possession of the sternmost, the national corvette *Le Nèarque*, of 16 guns, and 97 men.—29. The *Heureux*, 24, G. Younghusband, (Leeward Island Station) in company with the *Agamemnon*, 64, Sir E. Berry, captured the *Dame Ernoux*, French privateer, of 16 long-sixes, (which she threw overboard in the chase) and one 12-pounder, with 115 men.—29. *La Princesse Caroline de Grànville*, French, 6 guns, 33 men, taken by the *Greyhound* revenue cutter, R. Wilkinson, in the Channel. *Diligente*, French brig, 16 guns, 125 men, taken by the *Resard* sloop, 18, J. Coghlan.

April 4. The *Renoonnée*, 38, T. Livingstone, captured from under Fort Gallertes, the Spanish national brig *Vigilante* (since *Spider*), 18 guns, and 109 men.—6. War declared between Great Britain and Prussia.—6. The *Pallas*, 32, Lord Cochrane, having anchored close to the shoal of Cordovan on the evening of the 5th, the boats were dispatched into the Garonne, under the command of the First-Lieut. Haswell, accompanied by Sutherland, the master, Messrs. Perkyns, Crawford, and Thompson, together with the quarter-masters, and such of the seamen, the serjeant, and marines, as were fortunate enough to find place in the boats. About 3 A.M. they boarded, carried, and cut out, about twenty miles above the shoals, within two heavy batteries, the national corvette *La Trapageuse*, of 14 guns and 95 men, which had the guard. At daylight, the tide of flood running strong, they made sail: a general alarm was given; a sloop-of-war followed, and an action continued, often within hail, till, by the same bravery by which the *Trapageuse* was carried, the sloop-of-war, after an hour's firing, was obliged to sheer off, much damaged. While the *Pallas* was waiting at anchor for the return of the boats, three ships appeared in sight, bearing down upon her, and making many signals, which were soon perceived to be enemies. The anchor was instantly weighed, and with the remainder of the crew, his Lordship chased, drove on shore, and wrecked, one national 24-gun ship, one of 22 guns, and *La Malicieuse*, a corvette of 18 guns: their masts went by the board, and they were involved in a sheet of spray. The warrant officers supplied the place of those commissioned, who were absent in the boats. Three seamen were wounded.—8. *L'Isle de France* (French) brig, 8 guns, 72 men, taken by the *Duncan*, 38, Lord G. Stuart, in the East Indies.—9. *Vengador*, Spanish, schooner, 14 guns, 82 men, taken by the *Verginie*, C. Brace, Cork Station.—12. *Argonaute*, Spanish, 12, taken by the *Hydra*, 38, G. Mundy, on the coast of Spain. *Le Brava*, Edmond Boger, French, 74, taken on 6th Feb. 1806, foundered off the Western Islands, on passage from Jamaica; crew saved excepting 3.—16. *L'Intrepide*, French, 14 guns, taken by the *Hind*, Revenue cutter, T. M. Allan, in the Channel.—17. The *Sirius*, 36, Capt. Prowse, had an encounter with a formidable flotilla off the Tiber, consisting of one ship of 18 guns and 189 men, one brig of 20 guns and 160 men, two brigs (corvettes) of 12 guns each, and five heavy gun vessels. On closing with them just after sunset, they formed in compact order of battle. At seven a vigorous firing commenced from both sides, and continued at close quarters for two hours, when the *Commodore* in the ship hailed "He had surrendered." His gallant and determined resistance, together with the dangers of the shore, and the crippled condition of the *Sirius*,—(the smoothness of the water admitting the enemy to use their guns with the greatest effect,)—prevented the remainder of the flotilla being pursued. The captured ship was *La Bergere*, 18 guns and 169 men. The British had 1 officer, (the nephew of Capt. Prowse,) and 8 men killed, and 17 wounded.—19. The boats of the *Pompée*, under Lieut. Beacroft, brought out a merchant-vessel from *Scalvitra*, although protected by a heavy fire of musketry.—21. The *Reindeer*, sloop, 16, S. Fyffe, captured the French schooner privateer *La Creole*, pierced for 14 guns, but had only 6 mounted, besides swivels, and 59 men. Rear-Admiral Sir W. S. Smith, according to orders from Vice-Admiral Collingwood, assumed the command of the squadron off Palermo, composed

* These ships were the remainder of the French squadron which had committed great depredation upon the British commerce in the Eastern world.

† See 26th March.

of the *Pompée*, 80, his flag-ship, Capt. R. Dacres; *Excellent*, 74, F. Sotheron; *Athenienne*, 64, J. Giffard; *Intrepid*, 64, Hon. R. Wodehouse; *Eagle*, 74, Charles Rowley; and *Juno*, 32, H. Richardson. The French, then in possession of Naples, were besieging the strong fortress of Gaeta, which had a long time been preserved by the intrepidity and example of the Prince of Hesse, the Governor. After throwing into this fortress necessary supplies, and confiding to Capt. Richardson the execution of the naval part of sorties* to be made, in co-operation with a part of the garrison, against the enemy, Sir S. Smith proceeded off Naples, in order to draw off some of the attacking force to its defence, in which he succeeded.† Sir Sidney then proceeded to dislodge the French from the Island of Capri, which, from its situation, protecting the coasting communication southward, was a great object for the enemy to keep, and consequently one to be wrested from him. Capt. Rowley, of the *Eagle*, was directed to cover the landing of Marines and boats' crews. That officer placed his ship judiciously; nor did he open his fire till she was secured, and his distance marked by the effect of musketry on his quarter-deck, where the First-Lieutenant, James Crawley, fell wounded, and a seaman was killed. An hour's firing from both decks of the *Eagle*, with that of two Neapolitan mortar-boats, under Lieut. Rivera, drove the enemy from the vineyards within their walls. The Marines were landed, and led by Capt. Bunce; the seamen, under Lieut. Morrell, of the *Eagle*, and Lieut. Redding of the *Pompée*, mounted the steps, for such was their road nearest to the narrow pass, by which alone they could ascend. Capt. Stanmus, commanding the Athenienne's Marines, pressing forward, gained the heights, and the French commandant fell by his hand. A capitulation followed, and the garrison were allowed to march out and pass over to Naples, with every honour of war, after the interment of their brave commander with due respect.—22. *Princess of Peace*, Spanish, 14 guns, 23 men, taken by the *Loire*, 40, F. L. Maitland, at sea.—23. Sir S. Smith obtaining intelligence that the enemy had two 36-pounders in a small vessel on the beach at Scalea, sent the *Pompée's* boats in for them; but the French troops were too well posted in the houses of the town for them to succeed, without the cover of the *Pompée*, which accordingly stood in. A message was sent to the inhabitants to withdraw, which being done, a few of the *Pompée's* lower deck guns cleared the town and neighbouring hills, while the launch, commanded by Lieut. Mouraylian, drove the French from the guns, and took possession of them and the castle, the former of which, through extreme exertion, were conveyed to the *Pompée*, with twenty-two barrels of powder.—25. Lord Howick moved for an increase‡ of pay to the Navy. Two Dutch gun-boats taken by the *Archer* gun-brig, W. Price, off

* The projected sorties from Gaeta took place on May 13th and 15th in the morning, in a manner to reflect the highest credit on the part of the garrison and naval force employed. The covering fire from the fleet was judiciously directed by Capts. Richardson and Viengna. Two batteries were taken, and the guns spiked, with very little loss. The killed in taking Capri, and in the sorties of Gaeta, were six men.

† The city was at the time illuminated on Joseph Buonaparte's proclaiming himself King of the Two Sicilies. It was in the power of the English Admiral to have disturbed their festivity, but as the sufferers must have been the inhabitants of Naples and not the French troops, he humanely forbore, and made for the Isle of Capri.

‡ Estimate of the increased expense arising from the additional pay allowed to the officers and seamen of His Majesty's Fleet, between the 1st May and the 31st Dec. 1806.

	Per	£.	s.	d.	£.	s.	d.
To the Admirals of the Fleet	Day	0	10	0			
To Admirals	Day	0	7	6	1,831	1	8
To Vice-Admirals	Day	0	5	0			
To Rear-Admirals	Day	0	3	0			
To Captains in the command of ships of the 1, 2, 3, 4, and 5th rates	Day	0	3	0			
To Captains ditto of the 6th rates, Fireships, and Sloops of war	Day	0	4	0	16,996	16	3
To Lieutenants of all rates	Day	0	1	0	18,894	16	3
To Chaplains who perform the duty of Schoolmaster, where no Schoolmaster is borne	Year	20	0	0			
To Boatswains, Gunners, Carpenters, and Pursers, while in actual Commission	Month	0	6	0	4,680	0	0
To Master's Mates, Midshipmen, Sailmakers, Caulkers, Rope-makers, Masters-at-Arms, Clerks, Schoolmasters, Armourers, Carpenter's Mates, Gunner's Mates, Boatswain's Mates, Yeoman of the Powder Room, Quarter-Masters, Yeoman of the Sheets, Coxswains, Quarter-Master's Mates, Quarter Gunners, Carpenter's crew, Trumpeters, Gunsmiths, Sailmaker's Mates, Sailmaker's crew, Ship's Corporals, Caulker's Mates, Armourer's Mates, Stewards, and Cooks, in all rates	Month	0	5	0	53,328	3	4
To Captains of the Forecastle, Captains of the Tops, Captains of after Guard, and Captains of the Mast	Month	0	9	0	18,603	0	0
To able Seamen	Month	0	4	0	52,549	9	4
To Ordinary Seamen	Month	0	2	0	26,274	14	8
Total					193,168	2	4

Two

Cape Grisez.—20. La Sorciere, French, 10 guns, 46 men, taken by the Rebuff (G. V.) 12, C. Shackleton, Guernsey Road. Finisterre, French, lugger, 16 guns, 52 men, taken by the Minerva, 36, G. R. Collier, off Cape Finisterre.—27. Les Amis, French, letter of marque, 4 guns, 20 men, taken by the Actæon, 38, R. H. Mowbray, at sea.—28. The Hydra, 38, G. Mundy, after a chase of 230 miles, in Lat. 34 deg. 9 min. N. and Long. 9 deg. 20 min. W. captured the Spanish national schooner Argonauta, destined for Buenos Ayres with dispatches.—29. The trial of Lord Melville, impeached by the House of Commons, commenced* in Westminster Hall.

May 1. Le Pandour, French corvette, 18, taken by Rear-Admiral Sterling's squadron, N. Lat. 47 deg. 17 min. Long. 7 deg. 10 min. W. Irish Station.—2. Capt. J. Hellyar, Niger, captured the Spanish national schooner El Virgin del Connen from Algeiras, bound to La Guira with dispatches.—4. The boats of the Renouée, Capt. Sir T. Livingstone, and Nautilus, 18, under the direction of Lieut. Sir W. Parker† of the former vessel, gallantly boarded, carried, and brought out, from under the fire of the guns of the town and tower of Vieja, and also that of more than 100 musketeers, the Spanish national schooner Giganta, 9 guns and 38 men; 7 men were wounded.—5. La Cubrao, Spanish, row boat, 1 swivel, 14 men, taken by the Elk, doop, 18, W. F. Wise, Jamaica station.—6. Nostra Senora de los Dolores, or La Reparadora, Spanish, ship, 30 guns, 315 men, taken by the Adamant, 50, J. Stiles, off the Cape of Good Hope.—10. The French trade having been kept late in port, in a great measure by their knowledge of the exact situation of the British cruisers, constantly announced at the signal-posts, Capt. Lord Cochrane, of the Pallas, 32, endeavoured to stop this practice, by causing to be demolished the two posts at La Pointe de la Roche, and that of Caliola, and two in L'Ance de Repos, one of which Lieut. Haswell and Mr. Hillier, gunner, took in a neat style from upwards of one hundred militia. The flags were brought off, and the houses built by the Government burnt to the ground. On the 9th, Lieut. Norton of the Frisk cutter, and Lieut. Gregory of the Contest gun-brig, 14, volunteered to flank the battery on Point d'Equillon, while an attack was made upon it by land in the rear; but it was carried at once, and one man of the fifty who were stationed to the 36-pounders was made prisoner; the rest escaped. The battery was laid in ruins, guns spiked, carriages burnt, barrack and magazine blown up, and all the shells thrown into the sea. The signal post of L'Equillon, together with the house, shared the fate of the gun-carriages. A convoy got into the river beyond reach. Three of the British were slightly wounded.—14. Mr. Jeffrey brought forward charges in the House of Commons against Earl St. Vincent: he proposed twenty-four resolutions, which he moved to refer to a Committee of the whole House; twenty-two of the resolutions contained the statements and allegations from which the charges in the two last were deduced; and these were, that "during the time Lord St. Vincent presided at the Admiralty, the Royal Navy was not maintained in a complete and efficient state," and that "he was guilty of great negligence, misconduct, and dereliction of duty, in the office of First Lord of the Admiralty." This motion being negatived, Mr. Fox moved "That it appears to the House that the conduct of the Earl of St. Vincent in his late naval administration, has added an additional lustre to his exalted character, and is entitled to the approbation of the House;" and this resolution was carried without a division. General reprisals were ordered by the British Government against the ships, goods, and subjects of the King of Prussia, in consequence of the hostile measures adopted by him. Capt. Lord Cochrane, being close to the L'Isle d'Aix, reconnoitring the French squadron, discovered a frigate, and three brigs, getting under sail. The Pallas remained under topsails by the wind to await them: at half-past eleven a smart firing commenced. The main-topsail-yard of one of the brigs was cut through, and the frigate lost her aftersails. The batteries on L'Isle d'Aix opened on the Pallas, and a cannonade continued, interrupted on her part only by the necessity she was under to make various tacks to avoid the shoals, till one o'clock, when her endeavour to gain the wind of the enemy, and get between him and the batteries, proved successful. "An effectual distance was now chosen; a few broadsides were poured in; the enemy's fire slackened. I ordered ours to cease, and directed Mr. Sutherland, the master, to run the frigate on board, with the intention effectually to prevent her retreat by boarding. The enemy's side thrust our guns back into the ports; the whole were then discharged; the effect and crash were dreadful. The decks were deserted. Three pistol shots were the unequal return. With confidence I say that the frigate was lost in France, had not the unequal collision tore away our fore-top-mast, jib-boom, fore and main-sail, top-sail yards, spritsail yard, bumpkin, cathead, chain plates, fore-rigging, fore-sail, and bower anchor, with which last I intended to hook on, but all proved insufficient. She was yet lost to France, had not the French Admiral seeing his frigate's fore-yard gone, her rigging ruined, and the danger she was in, sent two others to her assistance. The Pallas being a wreck, we came out with what little sail could be set; and the Kingfisher sloop afterwards took us in tow."—DISPATCH. The Pallas lost 1 killed and 2 wounded.—15. La Aimable Theresa, Spanish, 2 guns, 18 men, taken by the Cerberus, 32, W. Selby, Jamaica station.—16. Government declared the coast, rivers, and ports from the Elbe to the port of Brest, both inclusive, to be in a state of blockade.‡ The Morne Fortunée brig, 10 guns, Lieut. J. Rorie, captured the French privateer La

Two Acts of Parliament were afterwards passed, in pursuance of a recommendation from the King, to empower the Governors of Greenwich Hospital, and the Directors of the Chest at Greenwich, to increase the allowance to out-pensioners of Greenwich Hospital, and to grant pensions to old, infirm, and disabled officers not provided for in that Hospital, in addition to their half pay.

* On the sixteenth day of the trial sentence was pronounced. See 12th of June.

† See October 21st and 22nd.

‡ This was to counteract the new and extraordinary means resorted to by the enemy for the purpose of distressing British commerce.

Lini, 2 guns and 47 men.—18. The Reynard, sloop, 18, J. Coghlan, after a chase of 64 hours, captured in Lat. 20 deg. 30 min. N., Long. 68 deg. W. the French national brig Diligente, (since Wolf,) of 16 guns and 125 men, with dispatches from France, which were thrown overboard. Grand Juge Bertolo, French, 7 guns, 120 men, taken by the Fortunée, 36, H. Vansittart, Jamaica station.—24. The French national schooner L'Imperiale, 3 guns, small arms, and 65 men, after a partial action with the Duke of Montrose packet, surrendered to the Cygnet, sloop, R. B. Campbell, Lecward Island station. At the same time, the Wasp, sloop, 18, B. S. Blunett, captured the Napoleon, privateer, (late His Majesty's cutter Dominica,) Lieut. Peter, 14, carried into Guadaloupe by the crew, who mutinied in absence of their commander. Afterwards sent on a cruise, and retaken by Wasp, sloop, B. S. Blunett.

June 3. The Morne Fortunée (See 16th May) Grove on shore, and destroyed, near Cape Enganna, the Spanish letter of marque schooner L'Almable Jenette, 2 guns and 20 men.—5. The boats of the Apollo, 38, E. Fellowes, Mediterranean station, succeeded in bringing out from under the batteries, where she had run on shore, a French brig, laden with 6 brass 24-pounder guns, carriages, and shot. Le Prospero, French, lugger, 14 guns, 46 men, taken by the Vestal, 23, S. T. Digby, in the Channel.—9. L'Observateur, French, 18, taken by the Tartar, 32, E. Hawker, West Indies.—12. The Lord Chancellor informed Lord Melville, "That the Lords had fully considered of his case, and had found him not guilty of high crimes and misdemeanours charged on him by the impeachment of the House of Commons."—13. La Henriette, French, ship, 20 guns, 124 men, taken by the Powerful, 74, R. Pamplen, East Indies.—18. The Morne Fortunée, 10, Lieut. Brown, Lecward Islands station, captured the French schooner privateer Hope, 4 guns and 44 men.—23. Lieut. Mulcaster, of the Minerva, 36, Capt. G. R. Collier, was dispatched with two boats belonging to that ship to scour Finisterre Bay. They returned with five Spanish luggers and a chasse-marée, mostly laden with wine. But as these vessels were under a fort, mounting eight guns, it was necessary to carry that fort, which was done in a most gallant manner by the bayonet and pike, before the guard had either time to raise the drawbridge or discharge a gun.—25. St. Joseph, Spanish, 2 guns, 30 men, taken by the Port Mahon, 18, Samuel Chambers, Jamaica station.—26. The boats of the Port Mahon, brig, 18, S. Chambers, cut out from the heavy fire of a battery to which she was moored in the Port of Banes, the Spanish letter of marque St. Joseph, armed with 7 guns, swivels, and musketry, and 30 men.—28. Buenos Ayres surrendered* to the land and sea forces under Major-Gen. Beresford and Commodore Sir Home Popham.† The Commodore, after surmounting all the difficulties in his progress up the river, arising from the shoalness of the water, adverse winds and currents, continual fogs, and great inaccuracies of the charts, anchored in the afternoon of the 25th, off Point Quelmev à Potichin, about twelve miles from Buenos Ayres. The army was landed without opposition, consisting of a detachment of troops from the Cape and from St. Helena, with a battalion, under Capt. King, of the Diadem, 64, composed of the Marines of the squadron, augmented with the addition of some scamen, and three companies of the Royal Blues. The operations were few and decisive. The British army amounted to 1634 officers and men, and the loss was very trifling. Prize money to the amount of 1,291,323 dollars was taken, 1,086,208 of which was embarked on board the Narcissus for England; the remainder being reserved for the exigencies of the service. The merchandise in the King's and Philippine Company's stores, with the little that was retained of floating property, was valued at between 2 and 3,000,000 dollars. The coasting vessels in the river, 100 in number, supposed with their cargoes to amount to 100,500,000 dollars, were restored to the proprietors. The squadron employed was the Diadem, 64, Commander Sir H. Popham, Capt. W. King; Narcissus, 32, Ross Donally; Reasonable, 64, J. Rowley; Diomedé, 50, Hugh Douman; Encounter (gun-brig) 14.

* Buenos Ayres was recaptured Aug. 12th following, and Major-Gen. Beresford, with the forces under his command, after a gallant defence, made prisoners of war.—See Military Annals of this year.

† Sir Home was originally appointed to the Diadem, in Dec. 1804, for the purpose of co-operating with Gen. Meranda to the extent of taking advantage of any of his proceedings which may not tend to our attaining a position on the continent of South America favourable to the trade of this country; but he had been afterwards given distinctly to understand, that from deference to Russia, all projects of that nature had been for the present abandoned; and when sent to reduce the Cape, no instruction, direct or implied, public or confidential, had been given him, which could authorise his leaving that colony, and employing the force under his command in any service unconnected with its conquest or preservation. Certain information, however, which he received soon after the capture of the Cape, determined him to carry off the whole of the naval force at the Cape, and attempt with it some exploit in the Rio Plata; and having persuaded Sir D. Baird to allow him a small body of troops under Major-Gen. Beresford, to co-operate in any enterprise he should attempt; he sailed from the Cape about the middle of April, leaving that settlement without an armed vessel to protect it from insult. He first proceeded to St. Helena, where he had the address to procure from the Governor a small reinforcement to his little army, and thence steered for the Rio Plata. When intelligence reached Government of his unauthorised departure from the Cape and meditated invasion of South America, orders were instantly dispatched to recall him home, and put a stop to his expedition. These orders were too late to prevent his enterprise; and when the news of his success arrived, the strong objections to his plan were drowned in the universal joy at the fortunate result of his operations.

BIRTHS, MARRIAGES, AND DEATHS.

BIRTHS.

June 23rd. At Ryde, the Lady of Capt. C. Lock, R.N. of a son.

June 30th. The Lady of Commander Alexander M'Konochie, R.N. of a son.

In Dublin, the Lady of Capt. Poyntz, 30th Regiment, of a son.

July 4th. At Southsea, the Lady of Commander Allen F. Gardiner, R.N. of a daughter.

At Lymington, the Lady of Capt. C. Rooke, R.N. of a daughter.

July 5th. At Bath, the Lady of Capt. Percival Lewis, H. P. 20th Foot, of a son.

At Pentuan, near St. Austell, the Lady of Lieut. F. Price, R.N. of a daughter.

At Falmouth, the Lady of Lieut. Church, of the Zephyr packet, of a son.

At Truro, the Lady of Lieut. Carne, R.N. of a son.

July 8th. In London, the Lady of Assistant-Surgeon John Bowling, Scots Fusileer Guards, of a son.

July 10th. In London, the Lady of Capt. White, R.N. of a daughter.

July 10th. At Cheltenham, the Lady of Major Roberts, Bombay Army, of a daughter.

The Lady of Lieut. Sidley, R.N. of a son.

July 14th. At Shortgrove Hall, the seat of Sir John St. Aubin, Bart. the Lady of Lieut-Colonel Knollys, of the Scotch Fusileer Guards, of a son, which survived its birth but a few hours.

July 16th. The Lady of the Hon. Capt. Bridgeman, R.N. of a son.

July 20th. At Portsmouth, the Lady of Capt. Harrison, R. M. A. of a daughter.

MARRIED.

June 9th. At Kennington Church, Alfred Tomlins, Esq. H.C.S. to Sophia, eldest daughter of Lieut. Hiram Frazer, R.N.

At Paris, by special licence, at the hotel of his Excellency the British Ambassador, Lieut. E. H. Finney, of the 62nd Regiment, to Eliza, daughter of the Rev. Professor Lee, Prebend of Bristol, Vicar of Barwell, and Chaplain to the Right Hon. the Earl of Munster.

June 30th. At Juniper Bank, near Thurso, Lieut. George Paton, H. P. late Cape Regiment, to Miss Sibella M'Iver, eldest daughter of Roderick M'Iver, Esq. Collector of Customs, Thurso.

June 30th. At Stonehouse Chapel, Lieut. J. Cornish, R.N. to Emily, youngest daughter of the late A. Uxborne, Esq. Purser R.N.

At Lymington, Lieut.-Colonel Hughes, of the Bombay Army, and nephew of the late Gen. Hughes, R. M. to Eliza Luther, youngest daughter of John Taylor, Esq. M.D. late Physician to His present Majesty.

July 2nd. At St. Andrew's Church, Plymouth, Major Henry Semple, of the 35th Foot, to Amelia Emma, daughter of Capt. T. Searle, R.N. C.B.

July 2nd. At Nuns Cross Church, Lieut. William Johnston, half-pay 51st Light Infantry, eldest son of the Rev. H. Johnston, of Malherry, county of Dublin, to Sarah Jane, youngest daughter of the late William Mills, Esq. of Cordoxtown,

county Kildare, and grand-daughter of Sir John Dillon, Bart.

July 5th. At Christ Church, Cork, Capt. Duncan M'Pherson, Esq. 27th Regiment of Foot, to Jessie, daughter of Capt. Maclean, of the same Regiment.

At Uphill, Major William Godley, Hon. E. I. Company's service, to Mary Anne, eldest daughter of Henry Hope, Esq. of Wells.

At Campbeltown, Lieut. R. Stuart, 28th Regiment, to Harriet, daughter of the late Capt. John Campbell, of H. M. Revenue cruiser, Prince of Wales.

July 7th. In Edinburgh, Capt. William Osborne, of the 71st Light Infantry, to Helen Stuart, eldest daughter of John Hamilton Colt, of Gartskerrie, Esq.

July 14th. At St. Pancras New Church, Lieut. C. K. Scott, R.N. to Frances Alsop, daughter of R. Scent, Esq. of Mill Hill, Hendon.

July 20th. At St. Mary's, Bryanstone-square, Capt. Bathurst, of the Scotch Fusileer Guards, to Emily, youngest daughter of H. Villebois, Esq. of Gloucester-place, and Marham House, Norfolk.

At Jersey, Capt. C. Franklyn, of the 84th Regiment, to Emily H. Torrens, youngest daughter of the late Lieut.-Colonel Popham.

At Kiltromer Church, Capt. Richard Manus, of the 54th Foot, to Letitia, daughter of Abraham Sandys, Esq. of Chesterfield, county Galway.

July 20th. At George's Church, Dublin, Commander Samuel Price, R.N. eldest son of Harrington Price, Esq. of West House, Brighton, and nephew to the Earl of Strathmore, to Dorothea Grace, eldest daughter of Hugh Kennedy, Esq. of Caltea, in the county of Down.

July 23rd. At Kingston Church, by the Rev. J. V. Stewart, Lieut. J. A. W. Hill, R.N. to Mrs. Heslop, widow of the late Capt. Heslop, 60th Regiment, and daughter of Jacob Owen, Esq. Landport.

DEATHS.

June 6th. At Newbury, Berks. Lieut.-Gen. Cockell.

LIEUTENANT-COLONELS.

Dec. 13th, 1830. At Keitah, Bengal, Maxwell, East India Company's Service.

June 15th, 1831. At Paris, O'Hara, h. p. Clan-alpine Pencibles.

MAJORS.

Sept. 15th, 1830. At Ramrad, Fort George, Mungo Campbell, East India Company's Service.

May 31st, 1831. At Chatham, Bentley, 16th Foot.

CAPTAINS.

Feb. 18th, 1830. D. Gordon, 7th Royal Veterinary Battalions.

Feb. 28th, 1831. Pemble, late Royal Invincibles.

May 17th. Stevenson, late Royal Invincibles.

May 24th. At Camplehay, Tavistock, Kelly, h. p. 51st Foot.

LIEUTENANTS.

Trydell, 55th Foot.

Sept. 28th, 1830. St. Hippolyte, h. p. 27th Foot.

Jan. 15th, 1831. J. Cameron, late 6th Royal Veteran Battalion.

Jan. Luby, h. p. Provisional Battalion Militia.

April 10th. At Chelsea, Nicholls, late 6th Royal Veteran Battalion.

April 20th. Thompson, h. p. 1st Foot.

May 16th. Schmidt's, h. p. 8th line German Legion.

May 18th. Hanna, h. p. 50th Foot.

June 2nd. E. Cameron, h. p. 92nd Foot.

June 11th. McCullough, late 1st Royal Veteran Battalion.

June 31st. At St. Clears, Scott, h. p. 103rd Foot.

CORNETS AND ENSIGNS.

Sept. 1828. Rose, h. p. 15th Foot.

March 9th, 1831. Lawson, late Royal Invincibles.

April 30th. Heyland, h. p. 10th Foot.

May 1st. Norman, late 2nd Royal Veteran Battalion.

May 2nd. Crozier, h. p. 89th Foot, Grenmalig, near Caledon.

May 10th. Bullock, h. p. Royal Waggon Train.

May 20th. At Bruff, Ireland, Sutherland, 69th Foot, killed by a fall from his horse.

June 7th. Quarter-Master Mountford, h. p. 22nd Dragoons.

MEDICAL DEPARTMENT.

Dec. 27th, 1830. At Mauritius, Deputy Purveyor White, h. p.

In the East Indies, Stephen Fisher, Esq. Purser of H. M. S. Southampton.

March 19th, 1831. On his passage from Bombay to the Cape of Good Hope, whither he was going for the benefit of his health, Major John Hawkins, F.R.S. Hon. East India Company's Engineers.

June 27th. At Newport, Isle of Wight, Lieut.-Colonel Robert Anwyl, late of the 4th Foot. He was appointed Ensign in that regiment in 1798, and accompanied it to Holland with the army under the Duke of York in 1799, when he was slightly wounded on the attack on the enemy's right at Zuyder Zee. He afterwards served with the 4th at Walcheren in 1809; at Gibraltar and Ceuta in 1810; at Torres Vedras and the affair at Barba del Puerco in 1811; at the storming of Badajoz, (where he was severely wounded;) at the battle of Salamanca, at the siege of the Castle of Burgos, and in the affair at Villa Mariel in 1812; in the battle of Vittoria, the storming of St. Sebastian, the passage of the Bidassou, and the action at Bidart in 1813; and at the investment of Bayonne in 1814, where he acted as Assistant-Adjutant-General to the left wing of the army under Gen. Colville. He then accompanied Major-Gen. Robinson to Canada as Brigade-Major, and commanded the light troops of his brigade on the movement against Plattsburg, on which occasion he drove in the American pickets with great gallantry. He rejoined the 4th in France, and was there during the three years' occupation, and afterwards followed it to the West Indies, where he remained till its return in 1826, when he purchased an unattached Lieutenant Colonelcy. He was appointed in 1827 to the command of the 95th, which he joined at Malta, but the climate of the West Indies had so materially

impaired his health as to compel him to resign it in 1830 and return to England. He was honoured with a medal for his distinguished conduct at St. Sebastian. His frank and obliging disposition, joined with his urbanity of manners and convivial qualities, will long endear his memory to his numerous friends. He has left a widow and two children.

June 30th. At Camden Town, Retired Commander John Warrall, R.N. aged 60.

At his seat Merton Abbey, Surrey, Rear-Admiral Isaac Smith, in the 79th year of his age. He entered the service in 1760, and was for some time on board the Grenville, a brig commanded by the celebrated Capt. Cook, then employed as Marine Surveyor of Newfoundland. He afterwards accompanied him in the Endeavour on a voyage to the South Sea. He was posted 1st of Dec. 1787, and subsequently commanded the Perseverance, 36, in which he served for several years on the East India Station, to which he had proceeded with Commodore Cornwallis in 1789. He obtained the superannuation of Rear-Admiral at the promotion of Flag-officers in 1807.

In London, Capt. Cummins, Retired Royal Marines.

July 9th. At Prospect, near Salisbury, Retired Commander A. Hupsman, R.N.

July 9th. Capt. George Argles, R.N.

July 12th. At Cheltenham, aged 83, General Sir Charles Green, Bart. Colonel of the 37th Regiment. He was appointed Gentleman Cadet in the Royal Regiment of Artillery in May 1760; and Ensign in the 31st Regiment, 10th of August 1765—he joined his regiment at Pensacola, in West Florida, in 1766; and was employed in 1768, by Brig.-Gen. Hallimand, on a particular service to New Orleans and the Natches on the Mississippi. In 1796 he removed with the regiment to Saint Augustine in East Florida, and in the same year obtained his Lieutenantcy. He was employed as an Engineer under Brig.-Gen. Haldimand, and detached with his company to New Providence in the Bahama Islands, in 1771; rejoined the 31st in the latter end of 1772, at the Island of St. Vincent, and served in the campaign against the revolted Charibs: that service being completed, he returned with the regiment to England in May 1773; was appointed Adjutant 31st of July following, purchased the Captain-Lieutenancy in November 1774; and succeeded to a company in February 1775. He embarked with his regiment in February 1776 for Canada, was present at the action of Trois Rivieres on the 8th of June 1776; and crossed Lake Champlain to Crown Point with the army, in October of that year. On the opening of the campaign of 1777, he was appointed Aide-de-Camp to Major-Gen. Phillips, second in command of the expedition under the orders of Gen. Burgoyne; and was present at the reduction of Monnt Independence and Ticonderoga, and at the action of Freeman's Farm on the 19th of September 1777, was wounded while delivering a message from Major-Gen. Phillips to Lieut.-Gen. Burgoyne. On the termination of that campaign, being included in the conveyance of Saratoga, he attended Major-Gen. Phillips to Cambridge, near Boston, where he remained until March 1778, and was then exchanged and went to England. Appointed Aide-de-Camp to Lieut.-Gen. Sir Adolphus Oughton,

Commander-in-Chief in North Britain; that General dying in 1780, Capt. Green rejoined the 51st Regiment in Canada, and was appointed Major of Brigade to the Montreal division in May 1761. On the conclusion of the war, he was included in the Brevet of Majors, dated 19th of March 1783; and purchased the Majority of the 61st in February 1788. On the breaking out of the war in 1793, he being then nearly at the head of the list of Majors of the Army, was appointed Lieut.-Colonel of one of the battalions formed from the Independent Companies; from which he exchanged in 1794 to the 30th Regiment, and proceeded in command of the corps to Corsica in May of that year. Towards the close of 1794, he was appointed Inspector-General of the Corsican corps, raised for the British service, but on the 30th Regiment being ordered to England in 1796, he resigned his office in Corsica. In 1796 he was appointed Civil Governor of Grenada; in 1797 he was promoted to the rank of Colonel, and in 1798 appointed Brig.-General. In 1801, his sight being much injured by the climate, he received permission to return to England for the benefit of advice. On the commencement of the war in 1803, he was appointed Brig.-General on the Staff in Ireland, and commanded in the Counties of Tipperary and Kilkenny; he was promoted to Major-General in 1803, removed to the Staff in England, and appointed to command at Dover and Deal. In January 1804, he was appointed Colonel of the Irish Light Infantry Volunteers; and ordered to Barbadoes to take the voluntary command of the troops on the Leeward Islands, in consequence of the death of Gen. Griffin; he arrived at Barbadoes in March, and in conformity to instructions received previous to his leaving England, sailed in April in command of an expedition against the Dutch Settlement of Surinam. The Dutch Governor having refused to capitulate, active operations were commenced, and with such success, that on the 4th of May the Colony surrendered to His Majesty's arms. Major-Gen. Green assumed the Civil Government of Surinam, and the command of the troops on the Coast of Guiana, and continued in it till May 1805, when, on account of ill-health, he returned to Europe; soon after his arrival he was created a Baronet. In May 1807, he was ordered to take the command of the garrison of Malta, where he remained till May 1808, when, on account of impaired health, he was allowed to resign the command. In August of the latter year he was removed to the 16th Foot; promoted to Lieut.-General in 1809; placed on the Staff, and appointed to the command of the Northern District in 1812; he was removed to the London District in the following year; in 1814 appointed Colonel of the 37th Regiment; and in 1819 promoted to the rank of General.

July 12th. At St. Helier, Jersey, Colonel Alexander Mackenzie. He was appointed Ensign in the 73rd, now 71st Foot, in 1779; served at Gibraltar during the whole of the siege, and is honourably mentioned in "Drinkwater's Gibraltar." After the reduction of the 2nd battalion, he joined the 1st in the East Indies. In 1787 he was appointed Lieutenant in the 36th Regiment, and in 1797 Captain. He served eleven years in the East Indies, and returned with the corps to

Europe, and accompanied it to the Coast of France, Mediterranean, &c. During seven years he commanded the grenadiers, and was constantly present with his company. In 1804 a second battalion being added to the regiment, Capt. Mackenzie was promoted to a Majority; in a few months the battalion was completed to its establishment, when the whole of the men were transferred to fill up the ranks of the 1st battalion. By the exertions of the officers, the 2nd battalion was again completed, and in 1807 proceeded to Jersey, from whence a draught of 300 men were ordered to join the 1st battalion under orders for embarkation at Cork. On this occasion, Major Mackenzie offered his services, to supply the place of Colonel Darrock, Major of the 1st battalion, then on the Staff in Scotland. On the arrival of Colonel Darrock in Portugal, Major Mackenzie was obliged to return to his duty with the 2nd battalion, Colonel Darrock being soon after appointed Assist.-Quartermaster-Gen. in Portugal, Major Mackenzie lost no time in again soliciting another employ, and obtained permission to do duty with the 1st battalion; he accompanied it to Walcheren, where he was dangerously wounded. In December 1810, he was appointed Lieut.-Colonel in the York Light Infantry Volunteers; and in 1811 proceeded to the West Indies, where he continued to serve till 1817, when the regiment was ordered home and disbanded. He received the brevet of Colonel 12th of August 1819. In the course of his services, Colonel Mackenzie was dangerously wounded, and experienced the loss of vision of an eye.

July 2nd. At Windsor, Colonel James M'Dermott, late of the Royal Military College, Sandhurst. In the year 1775, this meritorious officer joined the 29th Regiment, and with them was present through the whole of the American Campaign, from the relief of Quebec, until their return to England in 1787. During this period he was ever one of those most actively employed, and his conduct on each occasion was such as to gain him the applause and esteem of all his superior officers. On his return from America, at the request of Lord Easton, now Duke of Grafton, he disciplined the West Suffolk Regiment of Militia, then "raising," in such a manner as to draw forth the highest praise from His Grace and all who witnessed their manœuvring. In Ninety-four he was appointed by His Royal Highness the Prince of Wales, Adjutant to the 10th Light Dragoons, very soon after Cornet and Pay-Master; in 1795, Lieutenant, and in 1797, he purchased his troop. His conduct was such, that on his quitting the regiment and the Staff, on which during nearly the whole of this time he had been serving with most of the Cavalry Generals of the day, His Royal Highness was graciously pleased to express himself to this effect—"That nothing but the services of Capt. M'Dermott being required at the Infant Establishment of the Royal Military College, should have induced him to part with them, finding them as he did so valuable to himself." In proof of his regard, he presented Capt. M'Dermott with an elegant sword, the superscription on which stated His Royal Highness's high esteem and approbation of his conduct. He joined the Royal Military College at Marlow in 1803, and in 1807, was appointed Major and Superintendent of that Institution. In 1813, he

was promoted to the rank of Lieut.-Colonel, and in 1831 to that of Colonel. He retired from the College in 1829. During the protracted period of his service at that Establishment, the upright, zealous, and amiable character of Colonel M'Dermott acquired for him universal respect and regard. By his immediate friends, as well as by the numerous succession of Cadets who passed through the College, many of whom now hold high rank in the service, his worth will be held in affectionate remembrance. He was followed to the grave by his old associates at that Institution.

At Bath, Dr. M. Felix, Surgeon, R.N. aged 77.
 July 13th. At Blatchington, near Seaford, after a few days illness, James Walker, Esq. Rear-Admiral of the Red, a Companion of the Order of the Bath, and a Knight Commander of the Portuguese Order of the Tower and Sword. Admiral Walker was a most brave and distinguished officer, and had borne a part in a great number of those actions which, during the last half century, have so highly exalted the fame of the British navy. He was present on the celebrated 12th of April 1782, in the action between Lord Rodney and the Count de Grasse. He was present, also, in Lord Howe's victory on the 1st of June 1794. In Lord Duncan's action off Camperdown, on the 11th of October 1797, he commanded the Monmouth, and was engaged for an hour and a half with two Dutch ships of the line, both of which were compelled to surrender. In command of the Isis, on the 2nd of April 1801, he shared with the immortal Nelson in the dangers and the glories of the battle of Copenhagen; and in the Vanguard, in 1803, he distinguished himself during the blockade of St. Domingo, as much by his prudence and humanity, as on the former occasions he had done by his bravery. In the Bedford, 74, he had the honour of escorting the Royal family of Portugal from Lisbon to Rio Janeiro, on which occasion the Order of the Tower and Sword was revived, and conferred upon him by the late Emperor of Brazil. The Admiral was on a visit to an affectionate son, who, as a Lieutenant in the navy, has the command of the Coast-Guard Station at Blatchington, and in his arms, and those of his afflicted lady, he expired, in the 67th year of his age.

July 15th. In Wimpole-street, in his 80th year, Gen. Loftus, Colonel of the 2nd Dragoon Guards, and Lieut. of the Tower. A Memoir of Services in our next Number.

At World's End Passage, Chelsea, Mr. Patrick Gibson, at the advanced age of 111, formerly Purser in the Royal Navy. He entered the Navy in the year 1757, and in that year assisted in bearing Gen. Wolfe off the field at Quebec; continued in the service afloat up to his 90th year; had been in twenty-six general engagements, and continued to within a very short period of his decease in the full enjoyment of his mental and most of his physical faculties.

At Petersfield, Lieut. Robert Cross, R.N.

July 16th. At High Beach, Essex, Thomas Sotheby, Esq. Admiral of the White, aged 72. Mr. Sotheby entered the naval service at an

early age, and having passed through the various ranks of Midshipman, Lieutenant, and Master and Commander in quick succession, obtained the rank of Captain June 11th, 1783, when about 25 years of age. At the commencement of the war with the French Republic, he commanded the Daphne frigate, from which he was removed to the Andromeda, on the North Sea station. In June 1795, he was appointed to the Bombay Castle, 74, which ship was wrecked at the mouth of the Tagns the end of the following year. In 1798, he was appointed to the Namar, a second rate, and afterwards to the Marlborough, 74, which ship on the 4th of November 1800, struck on a ledge of rocks near Isle Glouat, where she hung for several hours, and was at last a perfect wreck, and soon after sunk at her anchors. The officers and crew were saved by the Captain, 74, and a Danish ship in company. On the 2nd of January, 1801, a Court-Martial was held for the loss of his ship, who decided "that no blame was attributable to Capt. Sotheby, his officers or ship's company for their conduct on that occasion." Capt. Sotheby was afterwards appointed to the Courageux, which he commanded until the termination of the war. On the 9th of November 1805, he was promoted to the rank of Rear-Admiral, and hoisted his flag on board the Dreadnought in 1806, in the Channel fleet, and remained there during the following year. Another promotion taking place 31st of July 1810, he was made a Vice-Admiral; and on the 19th of July 1821, further advanced to Admiral of the Blue.

July. Colonel Sir Ralph Hamilton, Knt. purchased a Cornetcy in the 17th Light Dragoons, 31st of March 1783, from whence he removed to the King's Dragoon Guards. In 1789, he entered the 3rd Foot Guards; and in 1793, at the breaking out of the revolutionary war, accompanied the first brigade to the Netherlands; he served throughout that campaign, and was present in all the principal actions which occurred, commencing with the attack of the wood of St. Arnaud on the 8th of May, and ending with the affair of Lannoi on the 29th of October; including the six weeks siege of Valenciennes, and the affair of Lincelles on the 18th of August. He made afterwards the campaign of 1799 in North Holland, as Aide-de-Camp to the Duke of Gloucester, then Prince William Frederick. From the 3rd Foot Guards, he exchanged into the 38th Foot, and subsequently became Major of the 71st. In 1809, he received the brevet of Lieut.-Colonel, and in 1819 that of Colonel.

July 18th. At Woolwich, Capt. Arthur Carter, R.A. aged 39.

July 19th. At Croydon, Lieut. S. Drewry, R.N. in his 38th year.

July 22nd. At Greenwich, Capt. Browell, Lieutenant-Governor of the Royal Hospital Greenwich.

At Falmouth, Lieut. Frederick Anson, R.N. late of the Racehorse sloop-of-war. He had returned to England in the Nymph packet, in consequence of ill-health.

METEOROLOGICAL REGISTER,

KEPT AT THE OBSERVATORY OF CAPT. W. H. SMYTH, AT BEDFORD.

JUNE 1831.	Six's Thermometer.		At 3 P. M.			Pluvia- meter Inches.	Evapora- tor Inches.	Winds at 3 P. M.
	Maxim. Degrees.	Minim. Degrees.	Barom. Inches.	Thermo. Degrees.	Hygrom. Parts.			
☾ 1	64.5	55.4	30.04	62.9	436	—	.152	N.N.E. light breeze.
☾ 2	68.8	50.0	30.10	67.0	367	—	.200	N. light airs, beautiful day.
☾ 3	69.8	57.2	30.13	68.0	410	—	.150	N.N.E. light breezes, fine.
☾ 4	68.3	60.0	30.17	68.3	428	—	.230	N.N.E. breezes, cloudy.
☾ 5	68.4	58.2	30.08	60.5	447	.075	.250	N.E. variable to N.W.
☾ 6	68.2	55.5	30.06	60.3	446	—	.115	N.N.E. squally, showers.
☾ 7	66.4	55.6	29.92	57.4	440	.020	.100	W. by S. light winds.
☾ 8	66.2	54.3	29.86	60.6	473	—	.180	W.N.W. light airs, fine day.
☾ 9	65.9	54.7	29.85	64.0	441	—	.185	S.W. fresh breezes, squally.
☾ 10	66.0	56.8	29.73	63.7	446	.134	.190	S.W. to W. fresh breezes.
☾ 11	65.8	59.0	29.74	64.0	440	—	.170	S.W. a gale, squally.
☾ 12	68.8	61.0	29.82	68.8	460	.234	.160	S.W. light steady breeze.
☾ 13	68.8	62.2	29.94	67.7	500	.280	.150	N.W. and W. light winds.
☾ 14	69.0	61.2	30.07	68.3	470	.024	.136	S.S.W. light airs.
☾ 15	68.1	60.8	29.83	64.0	405	—	.160	S. to S.W. light winds.
☾ 16	66.1	60.7	29.83	64.4	450	.083	.150	S.W. light winds, fine day.
☾ 17	65.5	58.0	29.92	65.7	449	.200	.170	S.S.W. fresh breezes.
☾ 18	66.7	60.0	29.94	66.3	500	—	.163	S.S.E. fresh breezes.
☾ 19	68.2	58.0	30.02	67.6	488	.232	.200	S.S.W. light breezes.
☾ 20	68.3	57.9	30.15	67.0	424	—	.175	S.W. light breeze, fine day.
☾ 21	70.5	60.8	30.14	70.0	451	—	.200	S.S.W. light airs, fine day.
☾ 22	70.3	60.6	30.10	70.7	395	—	.100	W. by S. fresh breeze.
☾ 23	72.1	60.8	30.12	71.0	383	.100	.091	N.E. light airs, cloudy.
☾ 24	72.2	60.7	29.86	64.0	423	.156	.100	N.W. light breeze.
☾ 25	63.9	58.8	29.72	60.7	475	.066	.120	S.W. light airs, cloudy.
☾ 26	61.0	56.8	29.74	60.8	500	.070	.098	N. by W. fresh breezes.
☾ 27	66.2	55.3	29.80	61.4	513	.160	.100	W.S.W. fresh breezes.
☾ 28	67.1	56.0	29.97	60.2	520	.060	.150	S.W. light breezes, cloudy.
☾ 29	61.2	57.5	29.98	61.2	532	.186	.080	W. by N. light airs.
☾ 30	60.3	56.8	29.98	60.3	539	—	.050	N. by E. light airs, cloudy.

On the 1st of June, the beautiful phenomenon of an occultation of Jupiter by the Moon, occurred. I observed it with my large achromatic telescope, under very favourable circumstances, and can therefore assert that it took place without any distortion, discolouration, or loss of light, whatever. The night was cloudless, and the weather exceedingly fine. I used a power of 118, and during the emersion, which was preceded by a few scintillating rays, I could perceive the segment of the lunar limb over Jupiter, cutting its belts with a fine black line. The following are the times, corrected for error, by the sidereal clock.

			h.	m.	s.	
Immersion of	☾'s second limb	17 45 29.30	—	—	—	Indifferent, the ☾ being low.
	Ditto	III Satellite	17 52 38.76	—	—	Sluggish at contact.
Emersion of	IV Satellite	18 29 37.26	—	—	—	Indifferent observation.
	Ditto	II Satellite	18 46 50.36	—	—	Good, but not instantaneous.
	Ditto	☾'s first limb	18 50 30.26	—	—	Seen through a light haze.
	Ditto	☾'s second limb	18 52 12.16	—	—	Tolerable.
	Ditto	I Satellite	18 54 58.46	—	—	Excellent observation.
	Ditto	III Satellite	19 00 23.26	—	—	Excellent.

The month, though rather anti-astronomical, presented a few fine nights, and on the 21st there was an occultation, the immersion of which was observed so favourably, that I here give it, for the sake of comparison, in case any of your correspondents were on the look out. Sidereal clock corrected.

		h.	m.	s.	
☽ Librae	Immersion	15 06 50.00	—	—	Very excellently seen.
	Emersion	16 10 35.00	—	—	Uncertain to several seconds.

The emersion was doubtful, from an accidental disturbance, at the moment. The power used was 63. The immersion was in the dark limb.

Crescent, Bedford,
July 1st, 1831.

W. H. SMYTH.

* * * The usual place of our Notices to Correspondents being pre-occupied, must plead as a general apology.

INDEX

TO THE

SECOND PART OF 1831.

- Actions and Occurrences, 132, 260, 574
 ——— of the British Cavalry, 357, 524
 Addiscombe, examination at, 418
 Affairs at Home and Abroad, 113, 257, 409, 553
 Africa, survey of west coast of, 36, 185, 319
 Albuera, battle of, 376
 Alexander, Capt. his account of a skirmish in Persia, 463
 Almeida, action fought near, 14
 Ambriz, town of, 37
 Amelia Island, 162
 America, democracy in, 291
 American war, recollections of the, 162
 Angle, trisection of, 406
 Anglesey, Lord, 525, 527
 Angola, account of the town of, 36
 Annals of the British Army, 280
 ——— Fleet, 131, 572
 Anne, Queen, letter of King Charles of Spain to, 512
 Anwyl, Lieut.-Col. Robert, death of, 581
 Appointments and Promotions, 126, 127, 277, 431, 432
 Architects, naval, case of, 103
 Architecture naval, importance of, 234
 Aristocracy, a duty of, 388
 Army, British, efficient state of, 43; remarks on the comparative services and rewards of the several branches of, 348; effects of its inexperience in naval affairs, 354; military punishment, 552
 Army, stations of, 1st of July 1831, 435
 ——— medical department, pay of, &c. 107; distribution and duties of, 227, 541; abuses in, 400, 401
 ——— a Voice from the, 441
 ——— Estimates, 564
 ——— Russian, strength and organization of, 118
 Arracan, account of the province of, 422
 Arrivals, Sailings, &c. 122, 268, 429, 560
 Artillery, British, 43; on the organization of, 47; state of, 106
 Ascension, island of, described, 493
 Atlas mountains described, 116
 Attraction, local, 427
 Austin, Lieut. letter to Capt. Beaufort, 494
 Badajoz, siege of, 328
 Badge of merit, observations on, 549
 Banks, Sir Joseph, and Capt. Cook, 102
 Barometer, portable, 115
 Barrington, Vice-Adm. spirited conduct, 148
 Battles, naval, 145
 U. S. JOURN. No. 33. AUGUST, 1831.
 Bayonet, on the use of, 9
 Beaufort, Capt. 413; letter to, 494
 Beckwith, Colonel, wounded, 383
 ——— Lieut.-Gen. his death, 439
 Belgium, affairs of, 113, 258, 410
 ——— Prince Leopold elected King, 553
 Belson, Lieut. humanity of, 267
 Bennett, George, his account of a recent visit to the Polynesian Islands, 194, 473
 Beresford, Marsbal, wounded, 55; his career, 376
 Bermuda, appearance of, 170
 Biden, Christopher, review of his work on Naval Discipline, 24; mutinous conduct of three of his crew, 33
 Biographical Memoirs—the late Admiral Sir Joseph Sydney Yorke, 215; the late Vice-Admiral the Right Hon. Sir William Johnstone Hope, 218; the late Rear-Admiral Sir George Sayer, 221; the late Admiral the Earl of Northesk, 339; the late Admiral Sir John Knight, 363; the late Vice-Admiral Viscount Torrington, 365; the late Sir Murray Maxwell, 531
 Birou, Dr. contribution of, 249
 Births, 142, 285, 438, 580
 Bismark, Count, 12
 Bissell, Capt. fate of, 24
 Blane, Sir Gilbert, 146
 Bornu, city of, 367
 Boteler, Lieut. attack on, 41
 Bourrienne's Life of Napoleon, reviewed, 94
 Bowie, Mr. murdered, 325
 Bradey, opinion of, 307
 Brandy, Capt. 190, 191
 Brazil, revolution in, 410
 Brenton, Sir Jahleel, report of, 244
 Brest, experiments on Marshall's gun-carriages at, 242
 Bridgewater, disastrous voyage of, 49, 264
 British infantry, on the equipment of, 202
 Brothers the prophet, 305, 312
 Brooke's Travels in Spain and Morocco, 537
 Brudenell, Lieut.-Colonel, 416
 Burke, Mr. maxim of, 89
 Burman Empire, views in, 240
 Burning, curious custom of, 478
 Burton, Capt. his trisection of an angle, 406
 Busacco, battle of, 381
 Bushen's Memorabilia, extract from, 7
 Byng, Sir John, general orders on relinquishing his command in Ireland, 556
 Byron, Admiral, letter of, 147
 Cabinet Atlas, completed, 241

- Cabinet Cyclopædia, noticed, 240, 537
 ——— Library, 240, 537
 Cadets, education of, 46
 Caillié's Travels to Timbuctoo, 425
 Camelford, Lord, memoir of, 245
 Camps, retrenched, 505
 Caravanserai, described, 484
 Carbines, construction of, 69
 Cartouch-box, its defective construction, 204
 Cavalry Board, 416
 ——— British, on the Peninsula, 59; fire-arms of, 69; actions of, 357, 522
 ——— British, merits of, 548
 ——— French, their conduct at Waterloo, 13, 524
 ——— light, distribution of, 205
 ——— movements, revised, 268
 ——— on the employment of, 344
 Ceylon, addresses and orders on the occasion of the 16th Regiment leaving, 252
 Chain-Messengers, 503; described, 504
 Chanticleer, late voyage of, 489
 Charles, King of Spain, his letter to Queen Anne, 512
 Charpentier, M. work translated by, 369
 Chesapeake, action of, 149
 Chesnut, on the growth of, 464
 Choiseul, Duke de, 248
 Cholera, epidemic, 249, 259, 410; quarantine for, 420
 Christoval Fort, 511
 Chronometers, knowledge of, 489
 Churruca, Admiral, experiments of, 369
 Cigar-smoking, practice of, 91
 Cipher to be employed on service, 246
 Clerk, Mr. statements of, 145, 146
 Coa, combat of, 378
 Cockburn, Rear-Admiral, 170
 Colbert, Gen. 524
 Colonies, service in, 343
 Colours presented to the 30th Regiment, 265; to the 70th Regiment, 420
 Combat, sham one described, 479
 Comets, calculation respecting, 314
 Commanders in the Navy, 267
 Compass, irregularities of, 415
 Congo, river, 185
 Congreve rockets, trial of, 470
 Constantinople, panorama of, 240; letters from, 300
 Contagion and Malaria, in fever, 109
 Cook, Capt. and Sir Joseph Banks, 102
 Copper caps, to render them water-proof, 515
 Corisco Bay, natives of, 322, 326
 Cork Yacht Club, 396
 Corps, changes in stations of, 121, 268, 558
 Cotton, Lieut.-Gen. Sir Stapleton, 522
 Couchman, singular costume of, 467
 Courts-Martial, on the constitution and practice of, 94; order respecting, 271
 ——— on Commander Williams, 123;
 ——— on Capt. Kelly, 270; on Lord W. Paget, 568
 Cove, Naval establishment, removal of, 556
 Cowes, regatta at, 397
 Crawford, Gen. 378
 Creagh, Mr. James, 167, 168
 Cuirassiers, French, bravery of, 526
 Dances of Rotuma, 479
 Darien, turtle-catching on the coast of, 267
 Deaths, 142, 285, 438, 580
 Deccan prize-money, non-payment of, 251
 Deception, island of, particulars of, 492
 Delagoa Bay, natives addicted to theft, 193
 Democracy, power of, 290
 Dickson, Commander, 414
 Diebitsch, Count, memoir of, 81; particulars respecting, 114; movements of, 258, 409; his death, 410
 Dining out, an adventure in Portugal, 92
 Dixon, Commander, pamphlet by, 96
 Dolling, Capt. club established by, 68
 Dominica, attacked by the French, 281
 Don, Gen. 178
 Donkin, Lieut.-Gen. Sir Rufane, 414
 Douglas, Sir Howard, 160, 161; new edition of his Essay on Military Bridges announced, 241; on naval gunnery, 373; his speech on the establishment of a Naval and Military Museum, 411
 Drill, suggestions on, 404
 Driver, Capt. 29
 Drummond Light, for light-houses, 77
 ——— Lieut. on correcting the compass in high latitudes, 413
 Dubitz, affair of, 7
 Dublin Bay Regatta, 118
 Dudhurst, H. W. on the proposition for a United Service Medical Society, 251
 Duelling, remarks on, 100
 Dundas, instructions of, 395
 Dyas, Ensign, bravery, 332, 334, 335, 337
 Ecliptic, obliquity of, 114
 Edinburgh Cabinet Library, noticed, 241, 537
 Editor's Portfolio; or Naval and Military Register, 113, 257, 409, 553
 Education of the sons of officers, 96
 Edwards, Lieut. his letter detailing the death of Capt. Logan, 253
 Ekins, Rear-Admiral, statements of, 145, 147, 148, 149
 Elliot, Capt. Hon. G. experiments by, 370
 Encke, calculations of, 314
 England, trade of, 295
 Epitaph on the late Colour-Serjeant Robinson, 487
 Epitome of English literature, 537
 Erromanga, island of, 479, 480
 Esteiras, Cape, 322, 323
 Etiquette, a point of, 251
 Family Classical Library, noticed, 240, 537
 Fernando Naronha, island of, 494
 Fever, contagion and malaria in, 109
 Finch, Capt. visit to Sandwich Islands, 194
 Fisher, Mr. on the course of the Niger, 262
 Fitz-Clarence, Col. created Earl of Munster, 259
 Fleet, British, annals of, 131, 572

- Fleet, on condemning smugglers to serve in it, 57
 — effects of intemperance in, 497
 Fleets, on conducting and manœuvring, 350
 Fletcher's History of Poland, noticed, 537
 Forman, Capt. assertion of, 315
 Fortification, &c. popular view of, 505
 Foster, Commander Henry, his death, 286 ; particulars respecting, 489, 495
 Fragments of Voyages and Travels reviewed, 385
 France, affairs of, 113, 258, 410, 553
 Fuentes d'Onore, battle of, 384
- Gafney, Roger, anecdote of, 333
 General Correspondence, 98, 242, 393, 538
 — Orders, Circulars, &c. 271, 567
 Gentlemen Pensioners, band of, 110 ; vindicated, 403
 Glennie, Lieut. his visit to the pyramids of Teotihuacan, 261
 Gordon and Co. Messrs. their Chain-Messengers, 504
 Gourgaud, Gen. 528
 Grasse, Count de, operations of, 150, 151, 153, 157, 158
 Graves, Admiral, 149
 — Thomas, his stand for a mercurial horizon, 193
 — Lieut. his improved Log-ship, 501
 Gravitation, theory of, 311
 Great Britain, affairs in, 113, 257, 409, 553
 Greece, affairs of, 410
 Green, Gen. Sir Charles, death of, 581
 Greig, Mr. 301
 Guaianeco Islands, 260
 Guayaquil, river, 267
 Guard-ships, squadron of, 270
 Gunnery, &c. popular view of, 505
 — naval, observations on, 369
- Halkett, Major.-Gen. Sir Colin, 174
 Hall, Capt. B. his letter on the Drummond light, 79 ; his Fragments of Voyages and Travels, reviewed, 385 ; suggestions against accidents by steamers, 538
 Hamilton, Colonel Sir Ralph, death of, 583
 Hardinge, Major.-Gen. 412
 Harmonicon, noticed, 241
 Harris's Lightning-conductors, 121
 Hauterseerk, Dr. Richard, 247
 Haverhill, noticed, 241
 Hayes, Sir John, letter of, 53
 Health, Board of, 421
 Herschel, Miss, comet discovered by, 314
 Heussinger, a German officer, 15
 Himalaya Mountains, described, 423
 Hinton's United States, noticed, 241
 Hood, Sir Samuel, his conduct vindicated, 149, 150, 151, 155
 Hope, Sir Wm. Johnstone, memoir of, 218
 Horizon, mercurial, stand for, 193
 Horse, adapted for Lancers, 205
 Hottentot beauties, 188
 Houston, Gen. 335
- Humming-bird, fact respecting, 261
 Hunt, Lieut. killed, 329
 Hurricane, dreadful, 264
- Ice islands, numerous, 491
 Independence Island, account of, 197
 India Army, 250
 Indian Army, *versus* that of St. Helena, 405
 Infantry, British, on the equipment of, 202 ; distribution of, 205
 Intemperance, effects of, in the fleet and army, and its remedy, 497
 Ireland, affairs in, 113, 257, 409
 — survey of the coast of, 270
 Irish, character of, 179
 Irwin, Mount, 254
- Jersey, on the defence of, 173
 Johnson's (Judge) Military Law, 540
 Jones, Capt. George, his death, 287
 — Col. work by, 64
 — Mr. statement of, 108
 — Mr. new barometer invented by, 115
 Jones's War in Spain, 506
- Kalm, Peter, remark of, 464
 Kelly, Capt. court-martial on, 270
 Kepler, conjectures of, 315, 317
 Kershaw, Capt. his Views in the Burman Empire, 240
 Kettle-drums, presented to the Life Guards, 262, 555
 King, African, visit to, 189
 — Capt. communication from, 259
 — Glass Town, ladies of, 320
 Knapsack, construction of, 204
 Knight, Admiral Sir John, services, 363
- Lake, Lord, defeats Jeswunt Rao Holkar, 283
 Lance, on the use of, 61, 76
 Lancers and Light Dragoons, 69
 Lander, Richard, his discovery of the course of the Niger, 262, 367, 423 ; account of the journey, 426
 Landport, new town of, 267
 Lawrence, Commander, on leather storm sails, 405
 — Mrs. lines by, 318
 — Sir Thomas, Life of, noticed, 537
 Lazaretto, formed at Constantinople, 301
 Leipsic, song of a peasant girl after the battle of, 23
 Leopold, Prince, elected King of Belgium, 410
 Letters from Constantinople, 300
 Life Guards, silver kettle-drums presented to, 262, 555
 Lieutenancy of the Tower, 554
 L'Heritier, Gen. 526
 Light cavalry and infantry, distribution of in the field, 205
 Light-houses, the Drummond light for, 77
 Lightning-conductors, 121
 Lithuania, forming the centre of the revolutionary districts, 223
 Loango Bay, 186

- Logan, Capt. killed, 253
 Log-ship, improved, 501
 Loire, French transport, 267
 Londonderry, Lord, his History of the Pen-
 insular War, 14
 Lopez, Cape, 186, 192
 Lowicz, Princess, 472
 Lumley, Gen. bravery of, 362
- Macerone, Col. on Rifle Cartridges, 513
 Mac Geechly, Major, killed, 334, 336
 Macintosh, Major, 332
 Mackie, Major-Gen. his death, 286
 Mackenzie, Colonel Alexander, death of, 582
 M^cDermott, Colonel James, death of, 582
 M^cLeay, Alex. letter of, 256
 M^cLeod, Capt. his death, 143
 ——— Major, gallantry of, 379
 ——— Major-Gen. drowned, 143
 Man, Edward, killed, 329
 Manderson, Capt. 50
 Mangroves, fatal influence of, 187
 Manœuvres, naval, systematic practice of, 350
 Marine, mercantile, on the discipline of, 24
 Marriages, 142, 285, 438, 580
 Marshall's gun-carriages, experiments on, 242
 Massey, Mr. invention of, 502
 Masters in the Navy, 399
 Mates in the Navy, grievance of, 107
 ——— compared with Ensigns
 in the Army, 399
 Mats, different, 476
 Matthew, Patrick, his Treatise on Naval
 Timber, 457
 Maxwell, Sir Murray, sketch of services, 531
 Mayumba Bay, 186
 Medical department, pay, &c. of, 107 ;
 abuses in, 400, 401
 Medical Staff of the Army at Home, dis-
 tribution &c. of, 227 ; comments on, 541
 Mephitic air in ships expelled, 557
 Mercurial horizon, stand for, 193
 Merthyr Tidvil, riots at, 409, 418
 Meteorological Register, 144, 288, 440, 584
 Micees of Hindostan, 552
 Midshipmen afloat, comforts of, 545
 Military achievements and occurrences, 288
 ——— punishments, 552
 Monkeys, sagacity of, 40 ; worshipped, 192
 Moondah river, 322, 323
 Morgan, Lieut. 167
 Morocco, account of, 116, 259
 Muffling, Gen. 528, 529
 Mulgrave, Earl of, his death, 143
 Murray, Brigadier-Gen. 62
 Museum, Naval and Military, formed, 225
 Musket, manufacture of, 202
 Mosquito Islands, 323
 Mutiny, observations on, 26
- Napier, Colonel, his work on the Peninsular
 War, 62, 63, 64 ; statements of, 357,
 358, 359 ; review of the third volume of
 his History of the War, 375
- National Library, notice of, 95
 Naval affairs, effects of inexperience in, on
 the part of the army, 354
 ——— and Military Museum, establishment
 of, 225, 356, 398 ; general meeting re-
 specting, 411 ; allusions to, 461, 554
 ——— and Military Policy, hints on, 455
 ——— and Military Register, 113, 257, 409,
 553
 ——— Battles, 145
 ——— Estimates, 561
 ——— Gunnery, observations on, 369
 ——— Manœuvres, thoughts on the syste-
 matic practice of, 350
 ——— Reminiscences, No. VIII. Dining
 Out ; an Adventure in Portugal, 92
 ——— Timber, observations on, 457
 Navy, masters in, 399
 ——— mates in, without rank, 399
 Nelson, Viscountess, her death, 287
 New Sporting Magazine, noticed, 241
 Newton, accusation against, 310 ; renown
 of, 318
 Newtownbarry, affray at, 409
 Niemen, river, some account of, 224
 Niger, discovery of the course of, 262, 367,
 423
 Niza, filthy state of, 183
 Northesk, Admiral the Earl of, memoir of his
 services, 339
 Norton's Rifle Shell, experiments with, 120
 Nugent, Colonel, address of, 117
- Oak, British, on the growth of, 462
 Officer, naval, requisite for, 387
 Officers, plan for educating their sons, 96
 ——— who served on the Peninsula and at
 Waterloo, 550
 Olivenza, surrender of, 178
 Ordnance Department, 272
 ——— Estimates, 125, 560
 O'Reilly, Dr. anecdote of, 330
- Padron, Cape, natives of, 38
 Paget, Lord Wm. court-martial on, 568
 Palmeiro, Cape, natives of, 41
 Parker, Capt. Sir Peter, killed, 172
 Parliament, dissolved, 113, 257
 Parliamentary proceedings, abstract of, 125,
 560
 Patagonia and Terra del Fuego, Scientific
 Expedition to, 259
 Patten, Capt. killed, 331
 Payne, Lieut.-Gen. Sir W. account of, 287
 Pearce, Commander Robert, 169
 ——— Nathaniel, Life, &c. of, 537
 Peasant Girl, song of one, 23
 Pedro, Don, arrives in London, 410
 Pendulum, experiments, 491
 Peninsula, conduct of the British cavalry on,
 59 ; history of the War in, 375
 Persia, Skirmish in, 483
 Phillimore, John, on condemning smug-
 glers to serve in the Fleet, 57

- Phillips, Sir Richard, opinion of, 316
 Plague, quarantine against the infection of, in Turkey, 300
 Poetry—Song of a Peasant Girl after the battle of Leipsic, 23; the Veteran to his Sword, 209; the Soldier's Bride, 318; United Service Recreations at Portsmouth, 349
 Point-blank, definition of the term, 369
 Poland, state of affairs in, 113, 258, 409, 553
 ——— Histories of, noticed, 537, 538
 Polynesian Islands, account of a recent visit to, 194, 473
 Ponsonby, Sir W. 525, 527
 Portugal, laws and institutions of, 291
 Powell, Lieut.-Colonel, his address to the 30th Regiment, 265
 Prescott, Lieut.-Gen. singular order of, 338
 President, American frigate, 171
 Privateer, French, captured, 390
 Prize-money, distribution of, 124
 Prizes advertised for payment, 560
 Promotion, tardy, 250
 Promotions and Appointments, military, 127, 277, 432, 570
 ——— naval, 126, 277, 431, 569
 Publications, new, critical notices and reviews of, 234, 375, 537
 Punishments, African, 321
 Quarantine in Turkey, 300
 ——— against the Cholera Morbus, 420
 Queries, 391
 Radical and the Foot Guards, 108
 Raper, Lieut. remarks on his method of Working a Day's Work, 536
 Read, Mr. S. on a new armament for ships-of-war, 234
 Recollections of the late American war, 162
 ——— of a visit to Warsaw, 467
 Recruits, standard of, 118
 Reform bill, 409
 ——— observations on, 289
 Regattas, utility of, 67, 396
 Reliance, hurricane experienced by, 263
 Reminiscences of a Subaltern, 177, 328
 Retreat, suggestions for, 546
 Reviews and Critical Notices—On the Constitution and Practice of Courts-Martial, 94; Bourrienne's Life of Napoleon, 95; Commander Dixon's Pamphlet, 96; On a New Armament for Ships-of-war and Razeing, 234; Colonel Napier's History of the War in the Peninsula, vol. iii. 375; Capt. Hall's Fragments of Voyages and Travels, 385; Life of Sir Thomas Lawrence, 537; Brooke's Travels in Spain and Morocco, 537; Life of Nathaniel Pearce, 537; Fletcher's History of Poland, 537; History of Poland, 538
 Rifle Cartridges, observations on, 513
 Robins and Hutton, experiments of, 238
 Robins, Benjamin, remarks of, 521
 Robinson, epitaph on Colour-Serjeant, 487
 Rogniat, Gen. work by, 61, 507
 Rooche, Mr. on pointing naval ordnance, 371
 Rosetta, attack on, 9
 Rotuma, island of, described, 198, 473
 Royal Astronomical Society, proceedings, 114
 ——— Geographical Society, meetings of, 115, 259, 422
 ——— Marines, state of, 492
 ——— Military College, examinations at, 417
 ——— Naval Schools, establishment of, 266, 421, 554
 Rudiger, Gen. 259
 Russell, Lord John, bill introduced by, 289
 Russian army, strength and organization, 118
 Russians, their system of war, 6
 Sabine, Capt. observations of, 493
 Sabugal, combat of, 382
 Sailors, their activity and energy, 15; character of, 30
 Sails, leather, 405
 St. Catherine, account of the island of, 490
 St. Helena, on promotion at, 250, 405
 St. Mary's, town of, 164
 St. Paul's Rocks, position of, 494
 St. Pierre, opinions of, 308
 St. Vincent, Lord, 386
 Salamanca, incident at the battle of, 54
 Samogitia, account of the duchy of, 223
 San Christoval, operations against, 328, 329
 Sardinia, statistics of, 557
 Sarmiento, voyage of, 260
 Saxe, Marshal, opinions of, 61
 Sayer, Rear-Admiral Sir G. memoir of, 221
 Schemloi, Capt. his plan for a lazaretto, 301
 Scientific Gazette, noticed, 241
 Scotland, extent of inebriation in, 497
 Sea-fighting, modes of, 352
 Semaphore Telegraph, illumination of, 535
 Serjeants' Pikes, 204
 Service, extraordinary length of, 120
 Seymour, Colonel, killed, 63
 Shark, its extraordinary sagacity, 185
 Shary, river, conjecture respecting, 367
 Ships-of-war, new armament for, 234
 ——— mephitic air expelled from, 557
 Shipwreck, remuneration for, 247; extraordinary case of, 427
 Shipp, John, 87th regiment, case of, 548
 Simmons, Capt. review of his work on the Constitution, &c. of Courts-Martial, 94
 Skirmish in Persia, 483
 Slaves, fate of, 185
 Slave-trade at Angola, 37
 Smugglers, on condemning them to serve in the fleet, 57
 Smith, Rear-Admiral, death of, 581
 Smyth, Capt. W. H. Meteorological Register kept by him, 144, 288, 440, 584
 Soldiers, means for preserving health, 247
 Soldier's Bride, 318
 Sotheby, Admiral, death of, 583

- Southard, S. L. letters of, 196
 Sporting Magazine, 538
 Staff, changes and alterations, 558
 Standard Novels, noticed, 240
 Steam Ships-of-war, on the mode of arming and fighting, 89
 Steamers, suggestions against accidents, 538
 Sterns, circular, 117
 Stevens, Lieut. remarks of, 239
 Stopford, Admiral Sir Robert, 414
 Subaltern, reminiscences of, 177, 328
 Superannuation, military, 98
 Survey of the West Coast of Africa, 36, 185, 319
 Sunday Library, 538
 Switzerland, military organization of, 453
 Sword, on the use of, 61

 Tactics, with reference to impending war, 1
 Talavera, conduct of the 23rd Light Dragoons at, 396, 545
 Talbot, Colonel, killed, 362
 Tamhameha III. King of the Sandwich Islands, letter to, 195
 Target Practice, 488
 Tarragona, siege of, 15
 Taylor, Colonel, his bravery, 358
Tectona grandis, or teak-tree, 460
 Teeth, hint for preserving, 552
 Temeamea, brig, lost, 475
 Teotihuacan, Pyramids of, 261
 Thetis, loss of, 427
 Timber, naval, remarks on, 457
 Tongatabu, island of, 477
 Torrington, Viscount, sketch of services, 365
 Trafalgar, battle of, disposition of the combined fleets at, 138
 Trench, Colonel, pun respecting, 330
 Trisection of an angle, 406
 Troki, town of, 224
 Tuckey, Capt. expedition of, 40
 Tucopia, island of, 477
 Tupinier, memoir on the French navy, 234
 Turkey, improvements in, 306; insurrection in, 410
 Turtle Catchers on the Coast of Darien, 367
 Twelve Nights, noticed, 240
 Tyerman, Rev. Daniel, voyage of, 427

 Uniform of the Unattached, 250
 United Service Medical Society, proposed establishment of, 111; remarks on, 251
 Recreations at Portsmouth, 349
 School, 398

 Universe, theory of, with Strictures on Commander Woodley's "divine system," 305
 Usagre, affair at, 363

 Valais, disturbances in, 410
 Vauban's notions of retrenched camps, 505
 Veteran to his Sword, 209
 Victor, Gen. 396
 Vidal, Capt. 192; appointment of, 270
 Villatte, Gen. 396
 Vincennes, visit to the Sandwich Islands, 194
 Vittoria, battle of, 17
 Vivian, Colonel, gallant affair of, 523
 Voice from the Army, 441
 Voltaire, maxim of, 509
 Von Saldern, system of, 630

 Wager, wrecked, 260
 Walker, Rear-Admiral, death of, 583
 Wall, Lieut. his plan for illuminating the Semaphore Telegraph, 535
 Wallace, Colonel Alexander, character, 181
 Walsingham, Lord, account of, 287
 War, on the system of, 1
 Warsaw, recollections of a visit to, 467
 Washington, Lieut. account of his visit to Morocco, 116, 259
 Waterloo, conduct of the French and British cavalry at, 13, 524
 Webster, Mr. 494
 Weiss, Lieut. his death, 286
 Whale, causes a shipwreck, 427
 White, Capt. his Naval Researches, 145
 Widows' Fund, suggestions respecting, 98
 Williams, Commander, court-martial on, 123
 Williams, Lieut. 495
 Wills, an American, anecdote of, 172
 Willow-tree, its naval properties, 466
 Wilna, town of, 223
 Windham, Mr. motion of, 281
 Woodley, Commander, strictures on, 305
 Works, detached, 510

 Ximenes, Colonel, addresses to, 252, 263

 Yacht Clubs and Regattas, 66, 396
 Yellow fever, ravages of, 109, 110
 Yeo, Sir James, extract of a letter from, 234
 Yeomanry cavalry, instructions for, 105; efficiency of, 210, 271; pay and allowances of, 273; manoeuvres of, 393
 Yorke, Admiral Sir J. memoir of, 215, 287
 Yeou, or Sakatoo river, 367, 368

 Zélé, French man-of-war, 158, 160

END OF THE SECOND PART OF 1831.