

REPAIR REQUEST LIST

1000 Central Boulevard
11/12/2018 12:45 pm

Please repair items noted and confirm credit requested.

3.1.2 - Roof: Coverings

SLIPPED SHINGLE(S)

Repair requested.

 Action Recommendations

Repair needed.

Recommendation

Contact a qualified roofing professional.



Over garage

3.3.1 - Roof: Flashings

DAMAGED FLASHING

Repair requested.

 Action Recommendations

Repair needed.

Recommendation

Contact a qualified roofing professional.



East side upper roof

4.1.1 - Building Exterior & Immediate Grounds: Siding, Flashing & Trim

DECAY

Repair requested.

➔ Action Recommendations

Decay was noted. Recommend having contractor thoroughly check all wood components for less visible decay when repairs are made.

Recommendation

Contact a qualified handyman.



Lower level kitchen door

4.2.1 - Building Exterior & Immediate Grounds: Exterior Doors

FAILED WINDOW SEAL

\$200 credit requested

➔ Action Recommendations

Replacement of affected panes needed.

Recommendation

Contact a qualified professional.



Deck french doors

6.1.2 - Heating: Equipment

NEEDS SERVICING/CLEANING

Have serviced and technician report on overall condition.

➔ Action Recommendations

Debris / dust buildup was noted and does not appear to have received regular servicing. Furnace should be cleaned and serviced annually. Recommend a qualified HVAC contractor clean, service and verify furnace functioning.

[Here is a resource](#) on the importance of furnace maintenance.

Recommendation

Contact a qualified HVAC professional.

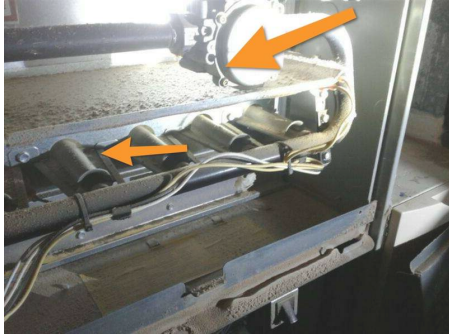

Right side basement unit

8.6.1 - Plumbing: Fuel Storage & Distribution Systems

CSST PIPE THROUGH WALL

Repair requested.



Safety Item Notes

Corrugated Stainless Steel Tubing was run through wall without protection. This is not generally permitted since this type of piping is easily damaged and may leak natural gas. Recommend this be reworked to avoid unintended damage.

Recommendation

Contact a qualified plumbing contractor.

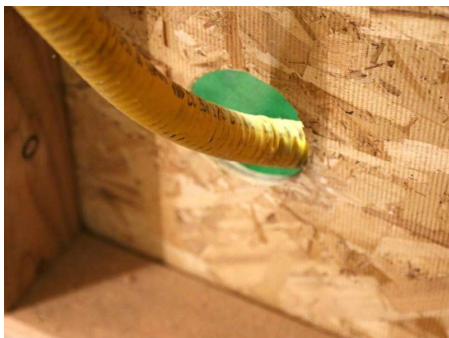

Behind basement furnace

9.3.1 - Electrical: Branch Wiring Circuits, Breakers & Fuses

MISSING JUNCTION BOX COVER

Repair requested.



Action Recommendations

Recommend all junction boxes be covered for safety and to meet current standards.

Recommendation

Contact a qualified handyman.



Attic over northwest BR

9.5.1 - Electrical: GFCI & AFCI

DID NOT TRIP

 Safety Item Notes

No shock protection provided. Replacement needed

Recommendation

Contact a qualified handyman.

Repair requested.

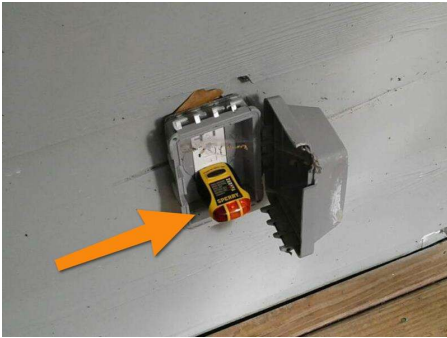

Pool pump house

10.3.1 - Attic, Insulation & Ventilation: Ventilation

INSULATION BAFFLES MISSING

 Action Recommendations

Recommend installing between insulation and roof sheathing. Insulation Baffles allow for proper air flow to reduce heat buildup in attic, which can shorten the lifespan of the roof covering materials.

Recommendation

Contact a qualified handyman.

\$500 credit requested



Various locations

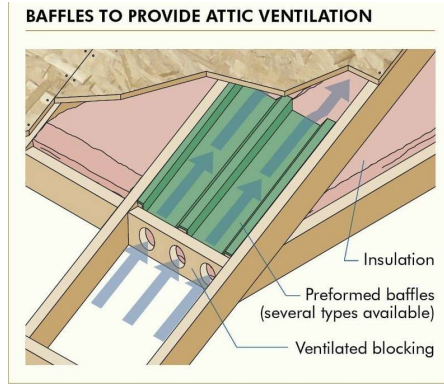

11.4.1 - Doors, Windows & Interior: Walls

STAIN(S) - TESTED DRY

Verify leak repaired.

Action Recommendations

There is a stain in need of repair / paint. Tested dry. Recommend consulting owner to verify the leak has been repaired.

Recommendation
Recommend monitoring.



2nd floor NE bedroom closet

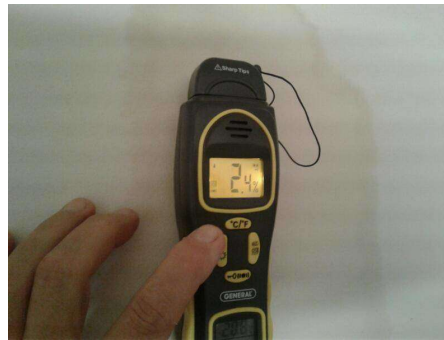

11.5.1 - Doors, Windows & Interior: Ceilings

STAIN(S) - TESTED DRY

Verify leak repaired.

Action Recommendations

There is a stain in need of repair / paint. Tested dry. Recommend consulting owner to verify the leak has been repaired.

Recommendation
Recommend monitoring.



1st floor laundry



12.3.1 - Appliances: Dishwasher

MISSING HIGH DRAIN LOOP

Repair requested.

 Safety Item Notes

The backflow of wastewater into the dishwasher is possible with this configuration, and can result in the contamination of dishes during the rinse cycle.

Position drain line as close to the underside of the counter as possible to create a high loop and ensuring the highest point of the drain line is above the entry point of the drain entrance.

Recommendation

Contact a qualified handyman.



1st floor kitchen

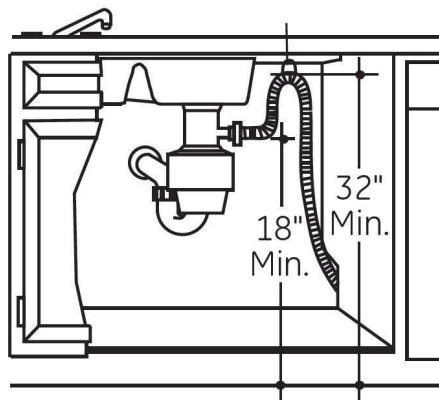

13.7.1 - Pool: Plumbing

LEAK NOTED

Repair requested.

 Action Recommendations

Repair needed.

Recommendation

Contact a qualified professional.



TOTAL CREDIT REQUESTED

\$700