A hand-drawn illustration of a workshop. On the left, there is a workbench with various tools and objects, including a drill, a screwdriver, and some cylindrical components. In the center, a large, 3D, blocky object is shown, resembling a stylized letter 'R' or a similar shape. The background is a solid orange color.

WHAT IF YOU WERE HAPPY
FOR JUST ONE SECOND:
INSTRUCTIONAL DIAGRAMS

JESSY RANDALL
DANIEL M SHAPIRO

**WHAT IF YOU WERE HAPPY
FOR JUST ONE SECOND:
INSTRUCTIONAL DIAGRAMS**

Jessy Randall & Daniel M. Shapiro



BOAAT PRESS

Amherst, MA USA

Copyright © 2014 Jessy Randall & Daniel M. Shapiro

BOAAT Logo by Florence Shearer

Portable Document Format

Text set in Georgia

www.boatpress.com

ACKNOWLEDGEMENTS

The authors gratefully acknowledge the literary journals in which some of these diagrams first appeared, sometimes in slightly different form: *Kugelmass*, *Menacing Hedge*, *Painted Bride Quarterly*, *Palooka*, *Red Lightbulbs*, *Scud*, *Seneca Review*, *Toad the Journal*, and *Vector*.

All drawings are originally from Raymond Bruman's *Exploratorium Cookbook: A Construction Manual for Exploratorium Exhibits* (San Francisco: The Exploratorium, 1976), adapted with permission, (c) Exploratorium, www.exploratorium.edu.

TABLE OF CONTENTS

WHAT IF YOU WERE HAPPY	1
REMAIN FASTENED	2
ALL MINE	3
PERFECTION	4
IT USED TO BE LIKE THIS	5
INTERRUPTIONS	6
INQUIRE WITHIN	7
REVERSIBLE SHADOWS	8
PLEASE HOLD	9
REMEMBER FORGET	10
PROVEN EFFECTIVE	11
POST	12
IBID.	13
MAZE FOR ONE	14
LISTEN FOR TONE	15
SOMEONE ELSE'S PAGES	16
SHE NEVER LISTENS	17
SOMETIMES	18
TAKE A DEEP BREATH	19
THINKING TOO HARD	20
VERY UNIQUE	21
TWO BENCHES	22
TRY NOT TO PICTURE IT	23
WE'RE NOT THERE YET	24
WAVE TABLE	25
FORGET IT	26
GROOVE	27
CRITICAL ANGLE	28
HOT SPOT	29
DO NOT HESITATE	30
RESTART	31
BIOGRAPHIES	32

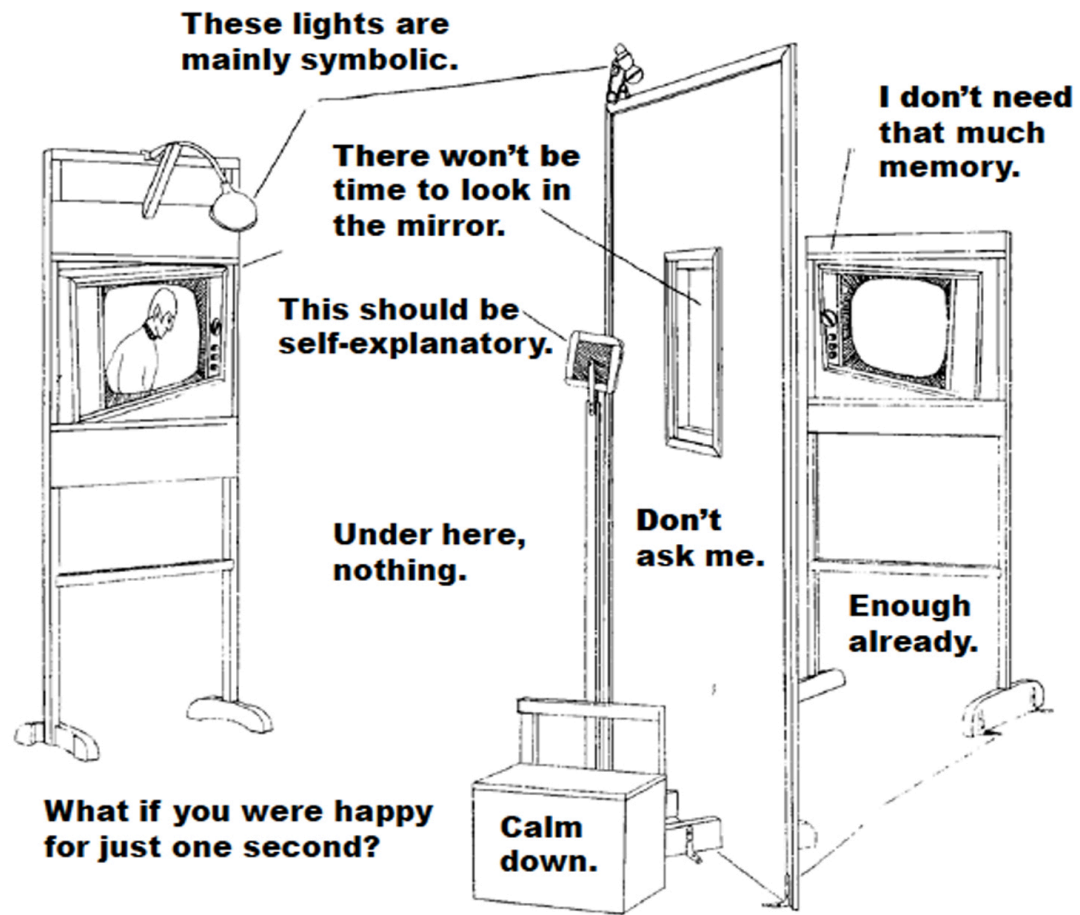

Remain fastened

Stay in perfect order

Do not go into holes

Stand up straight

Make eye contact

Ignore the wall

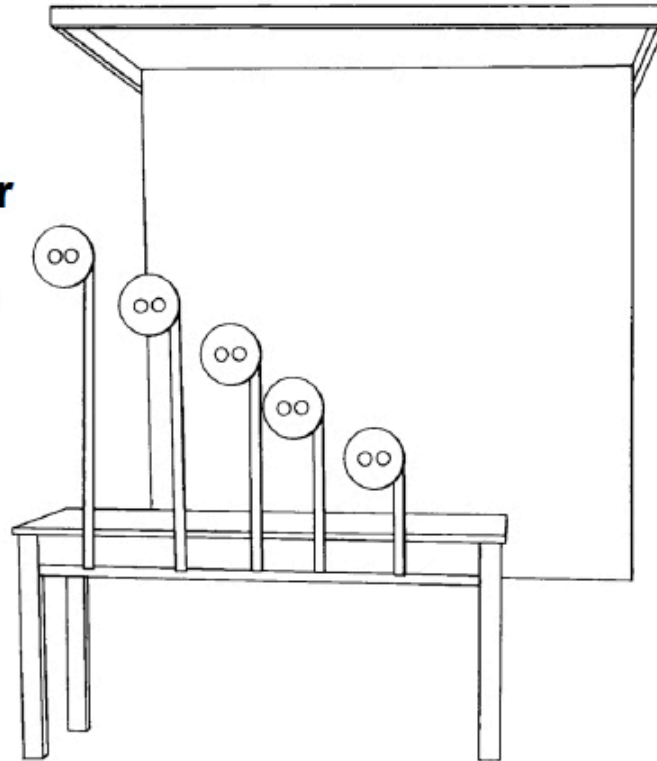

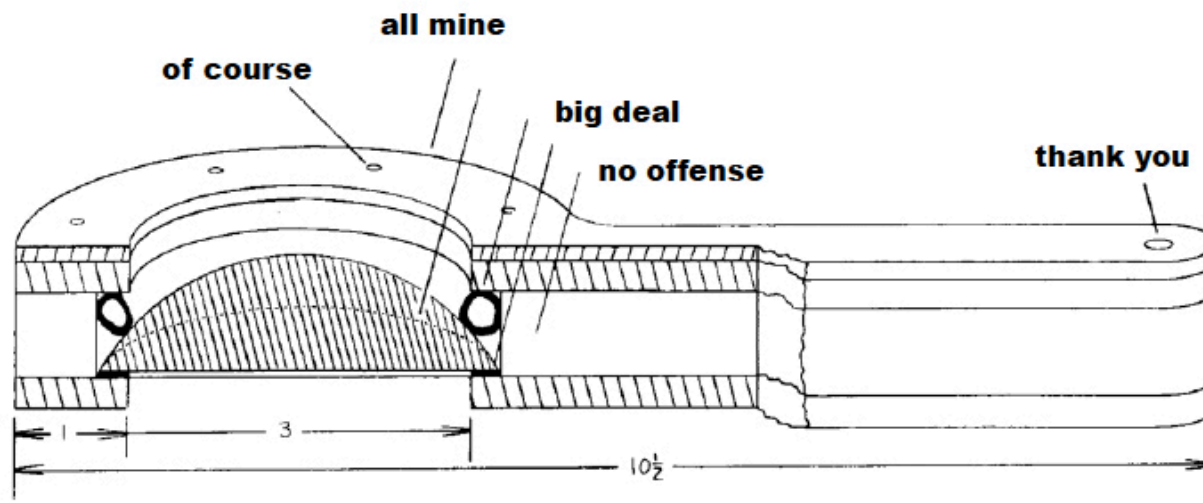

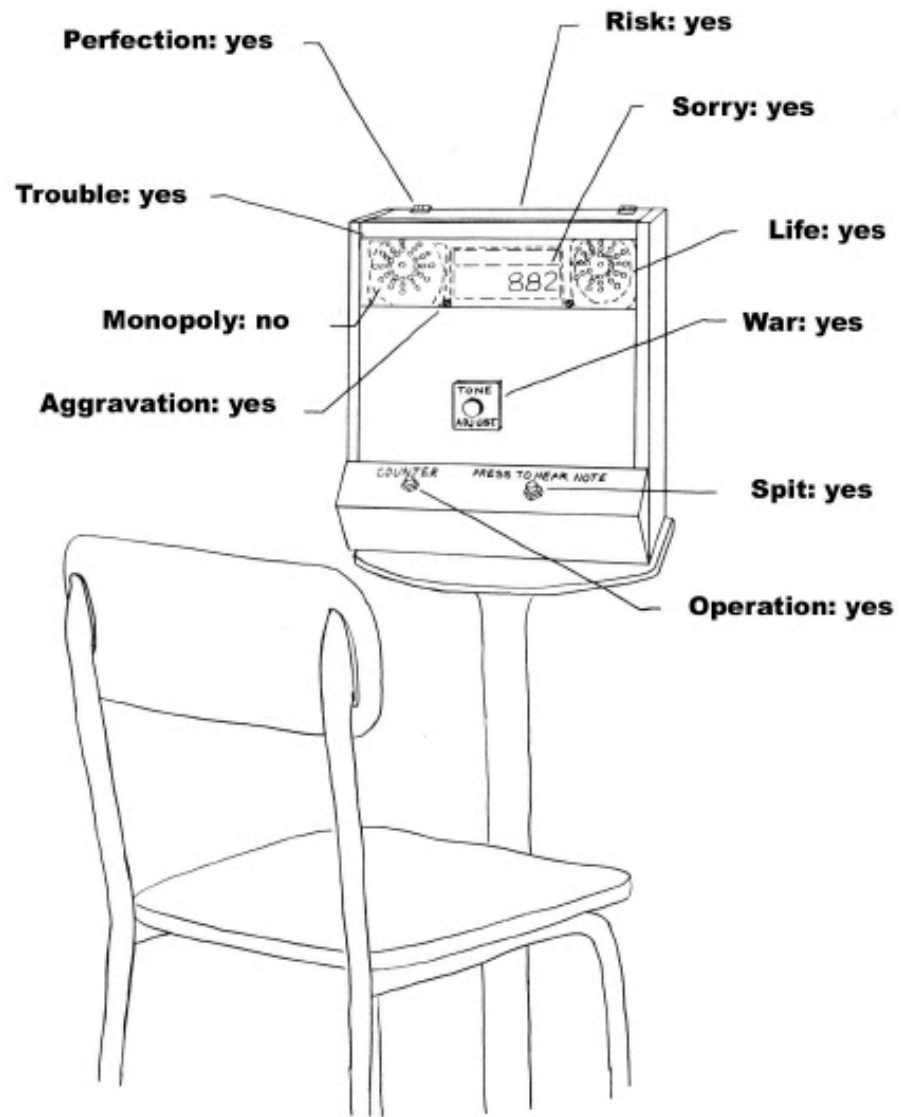

**It used to be like this,
but now it's like this.**

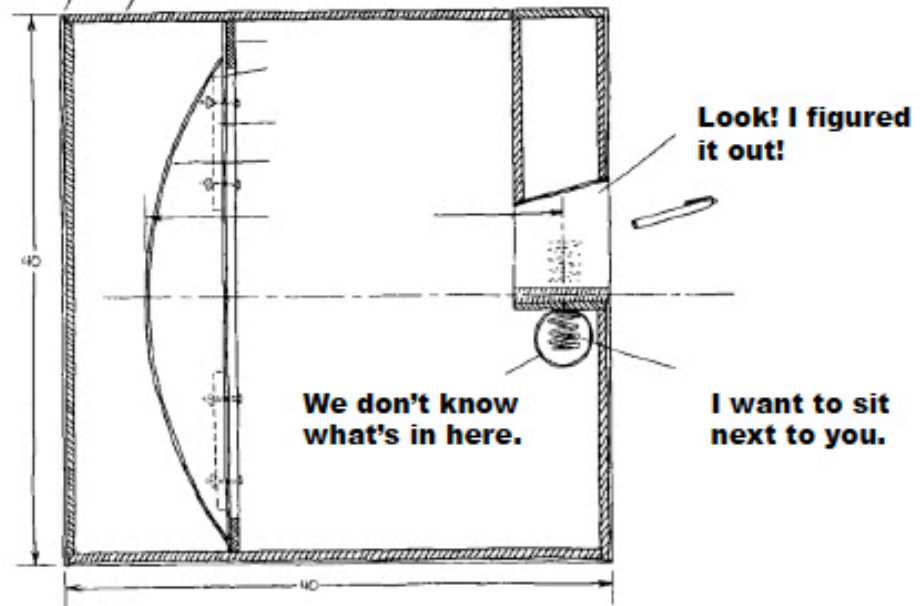

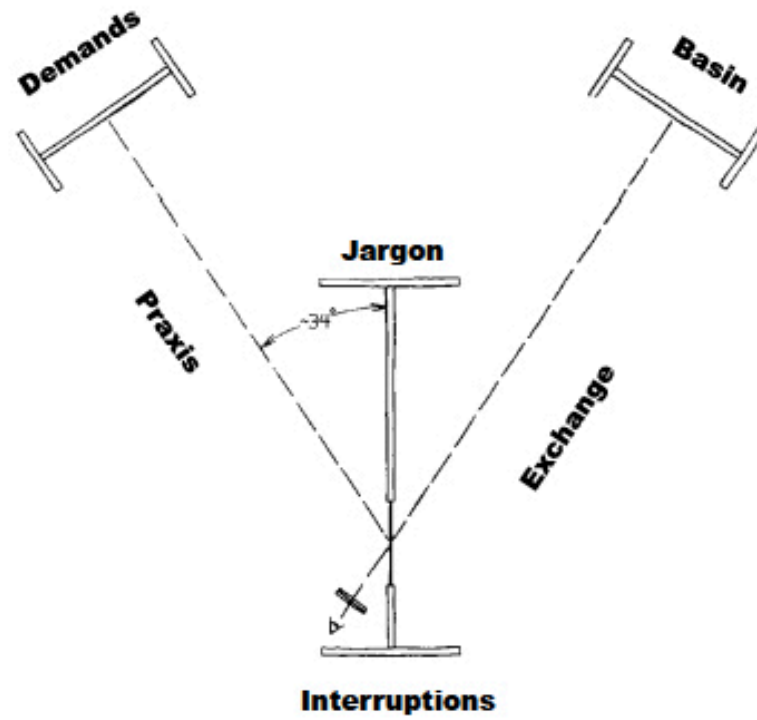

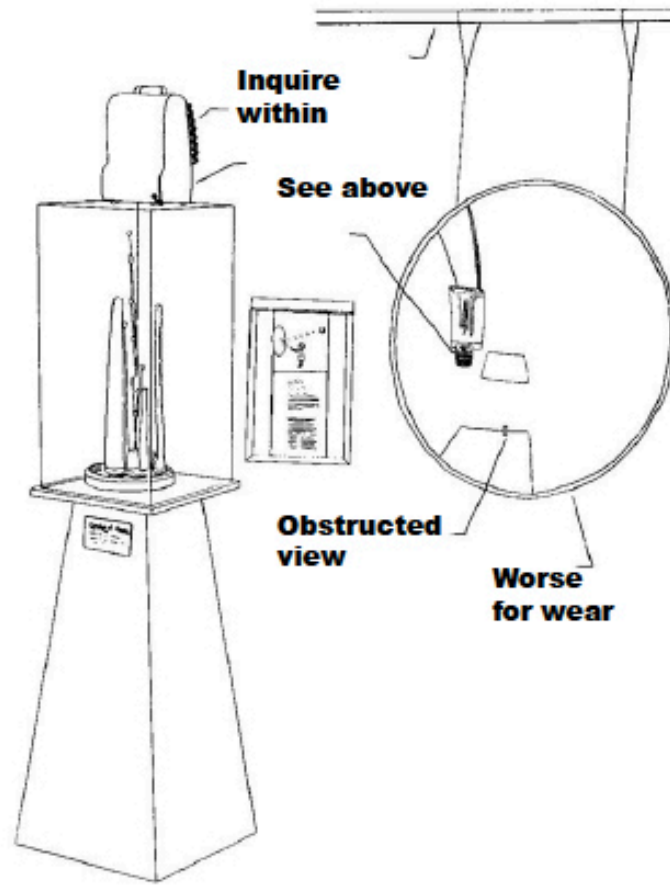

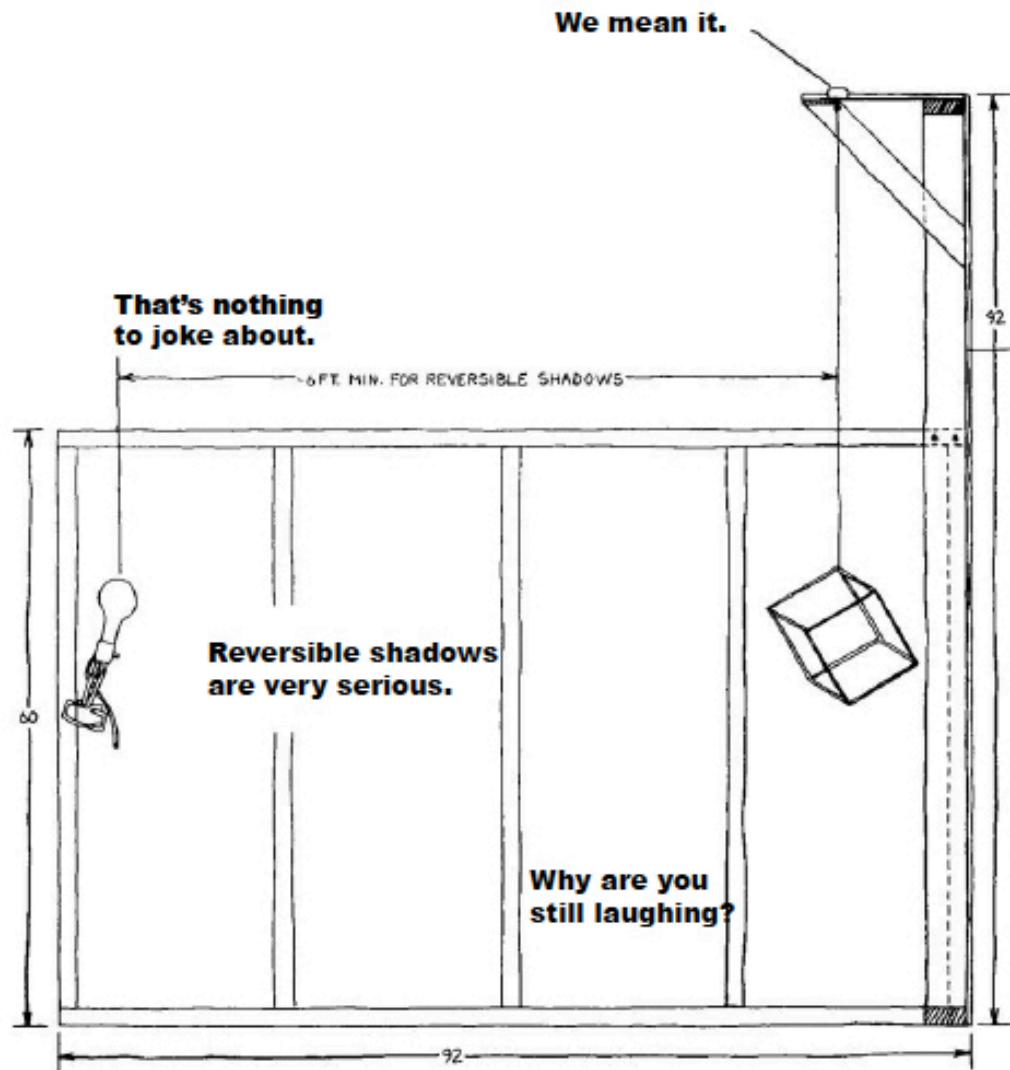

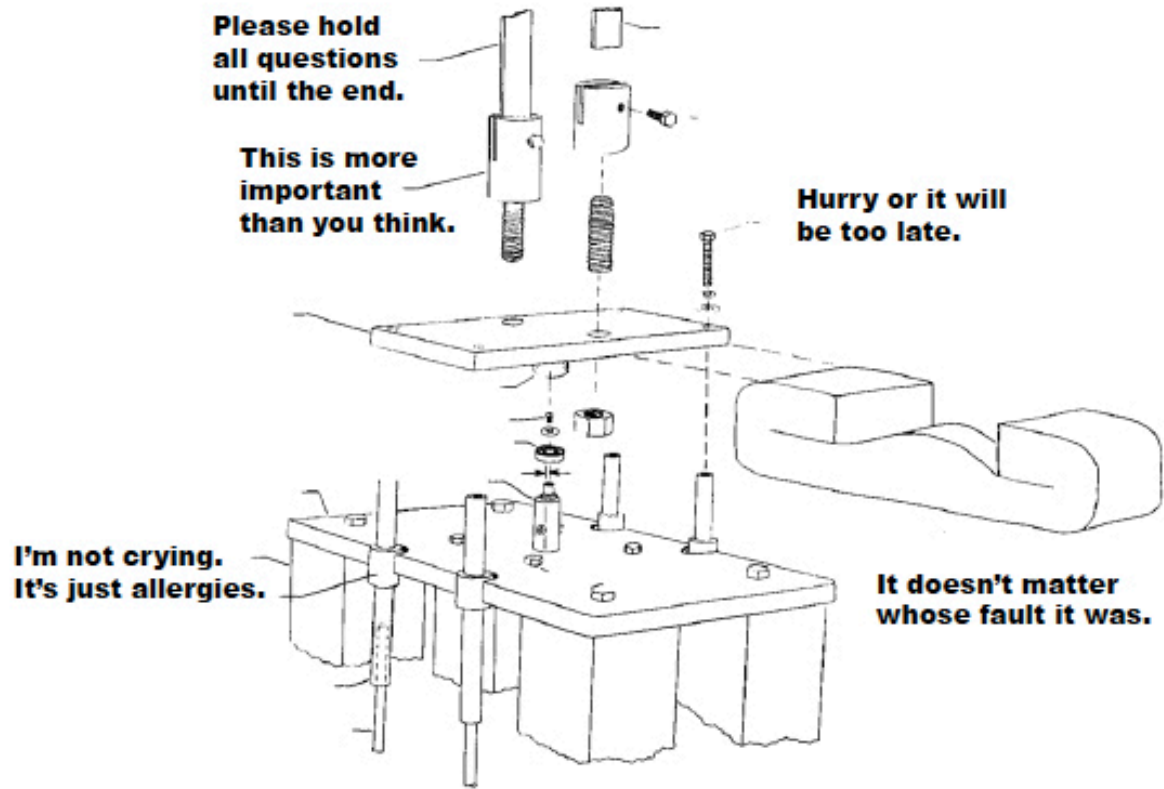

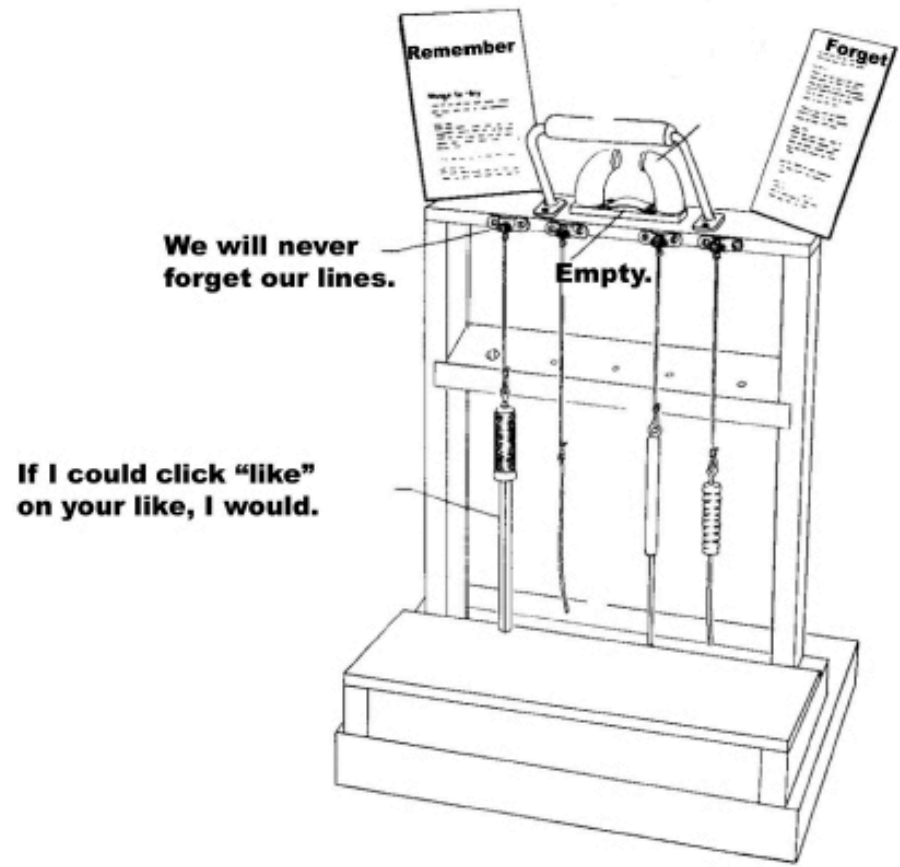

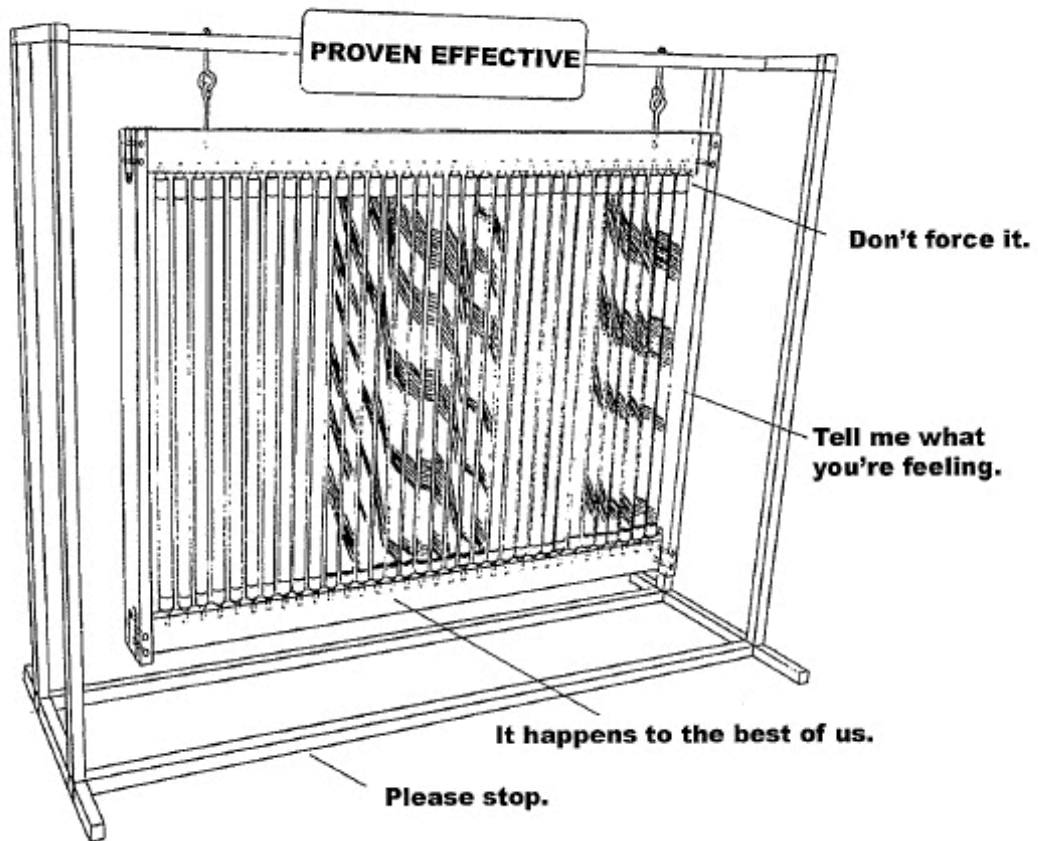

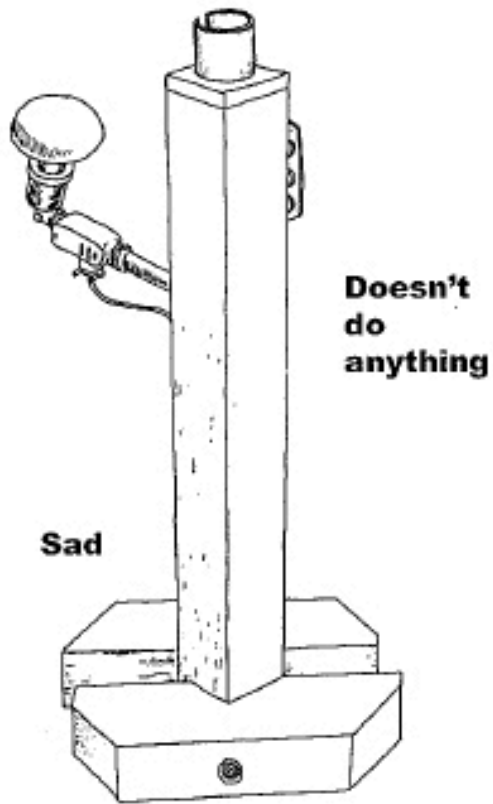

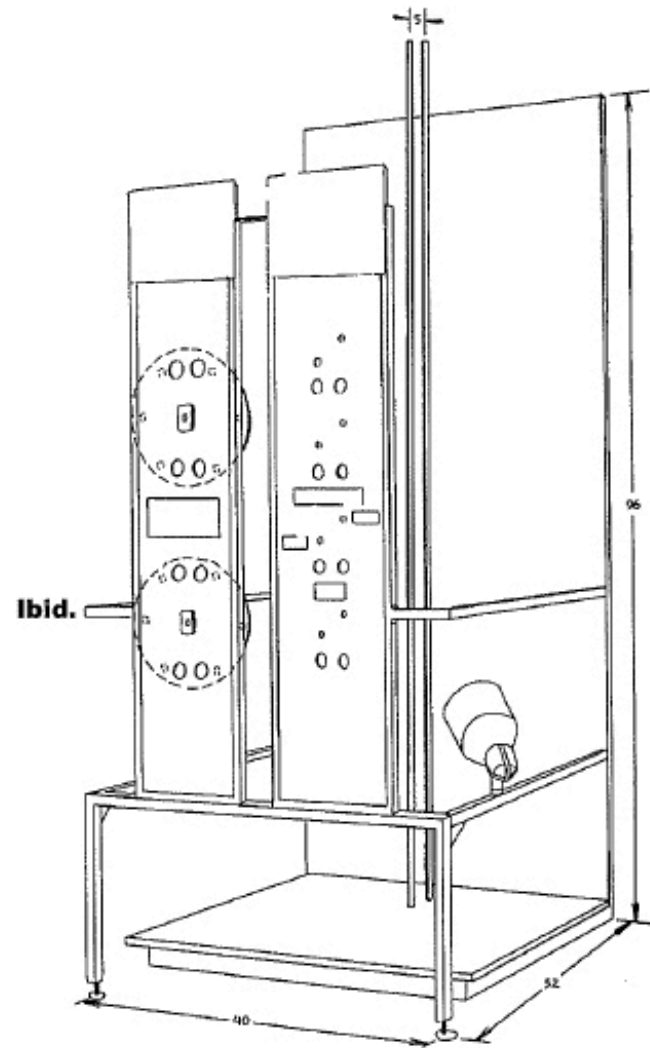

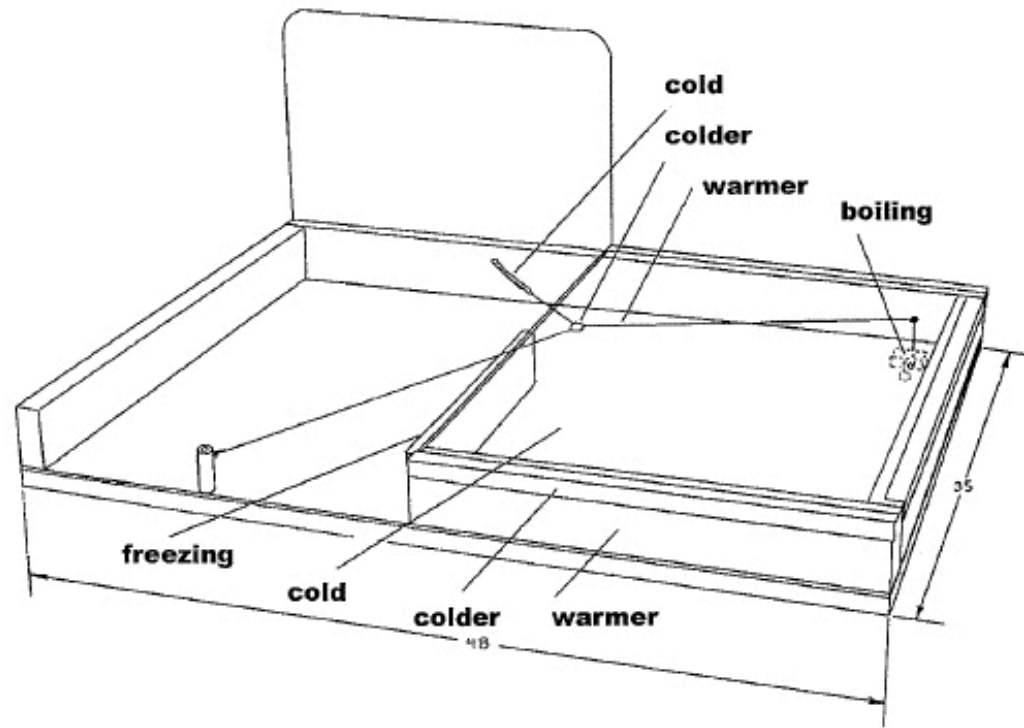

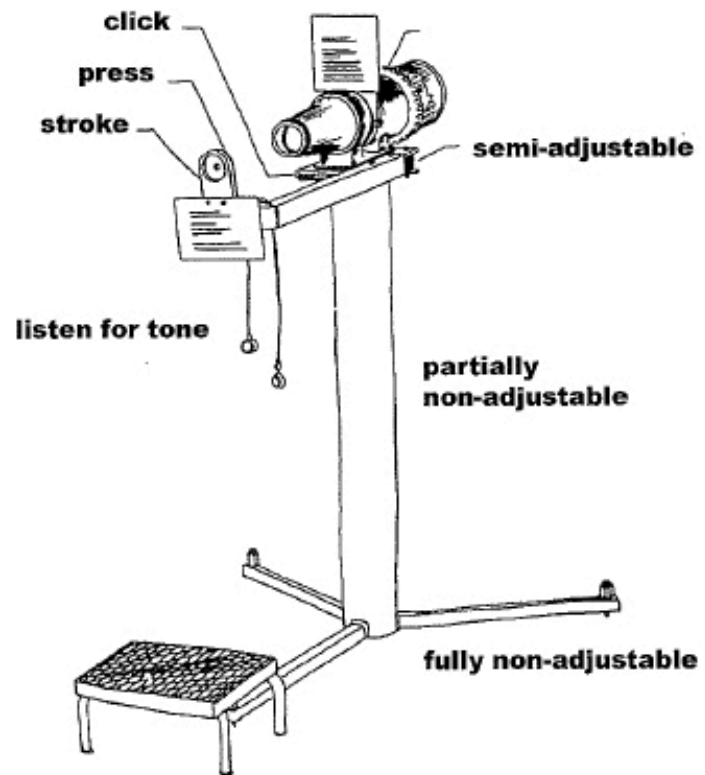

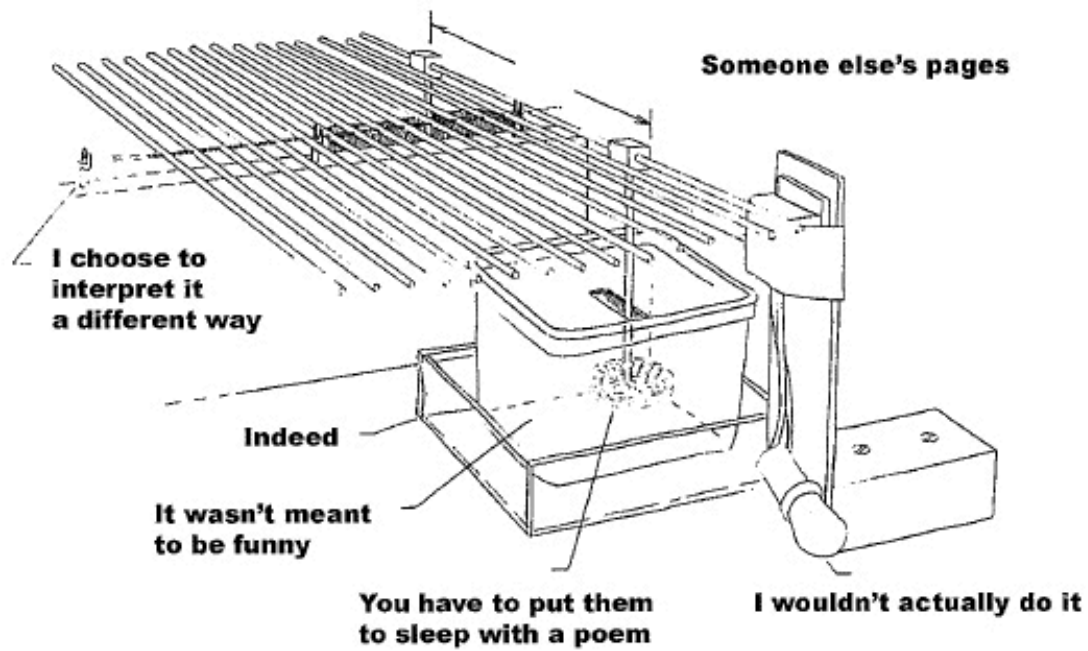

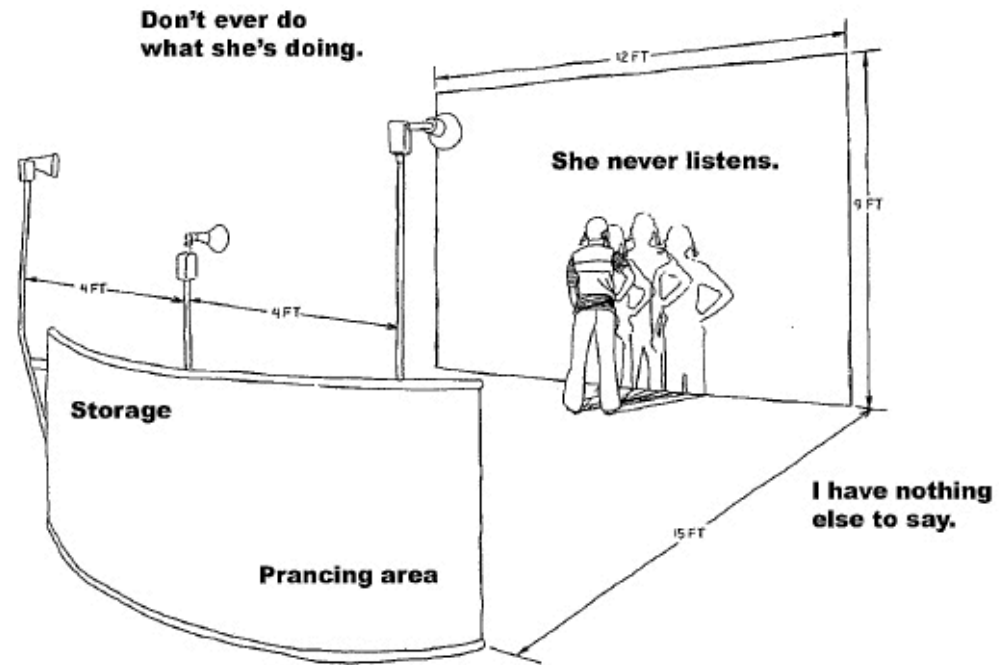

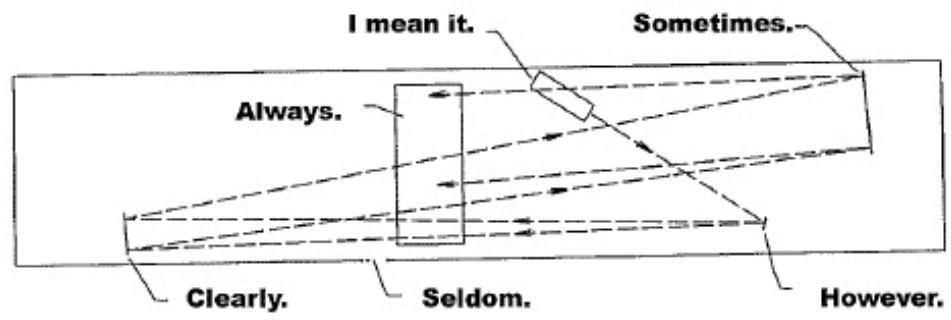

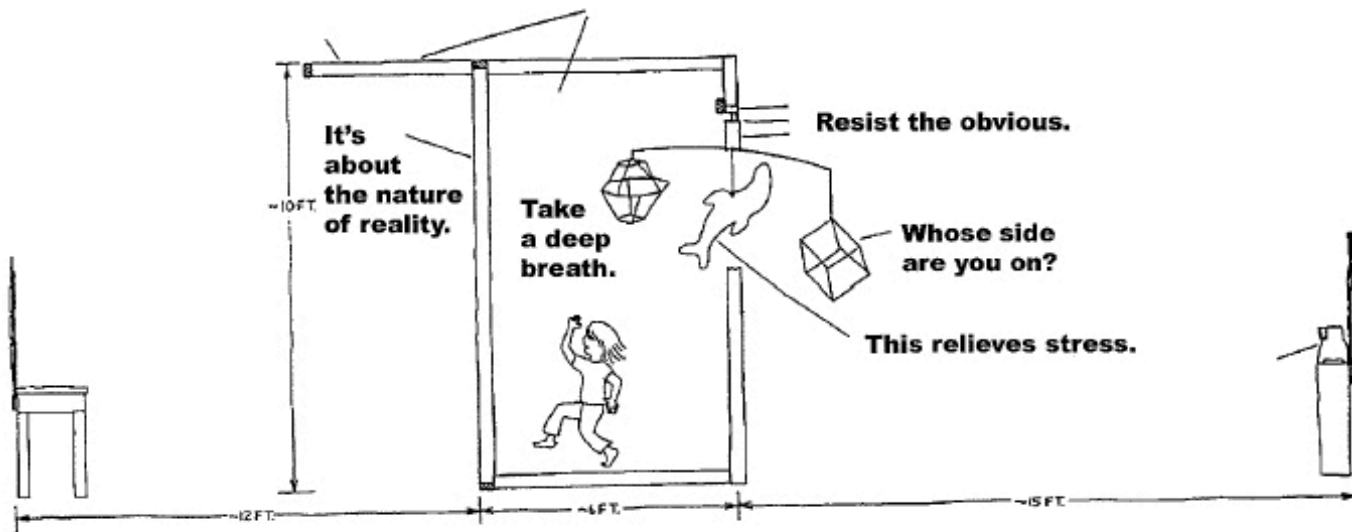

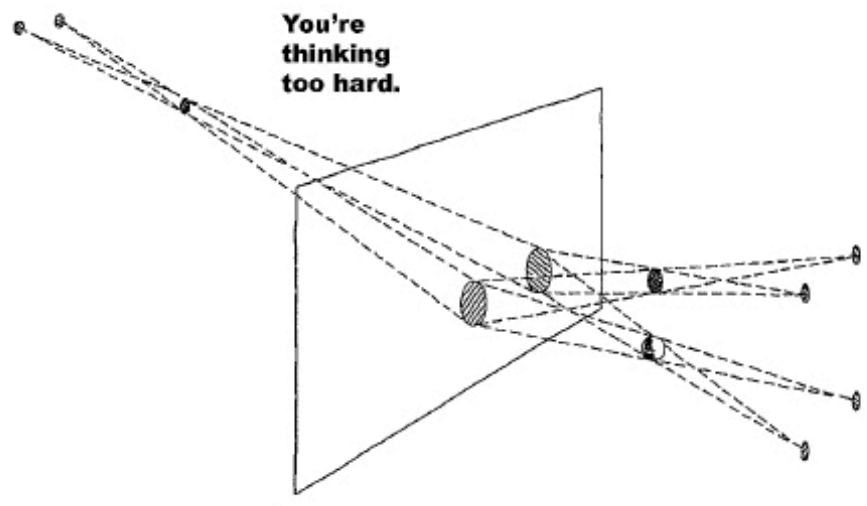

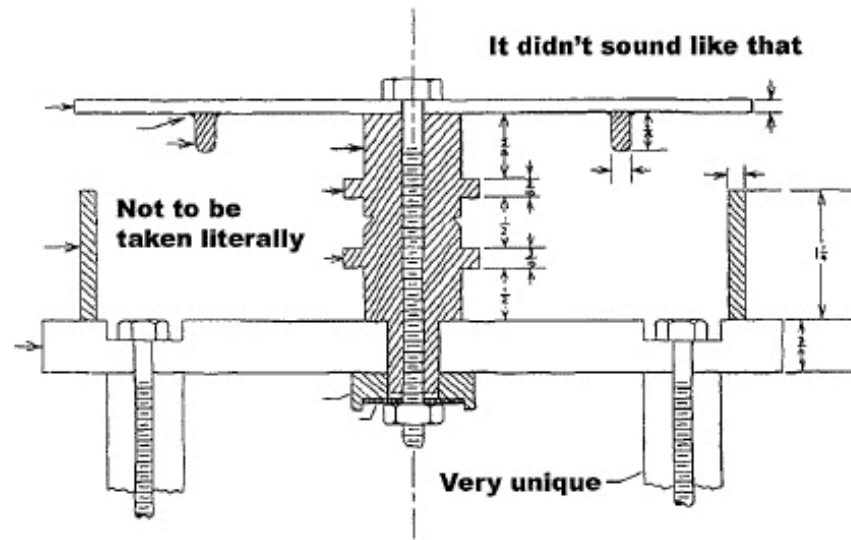

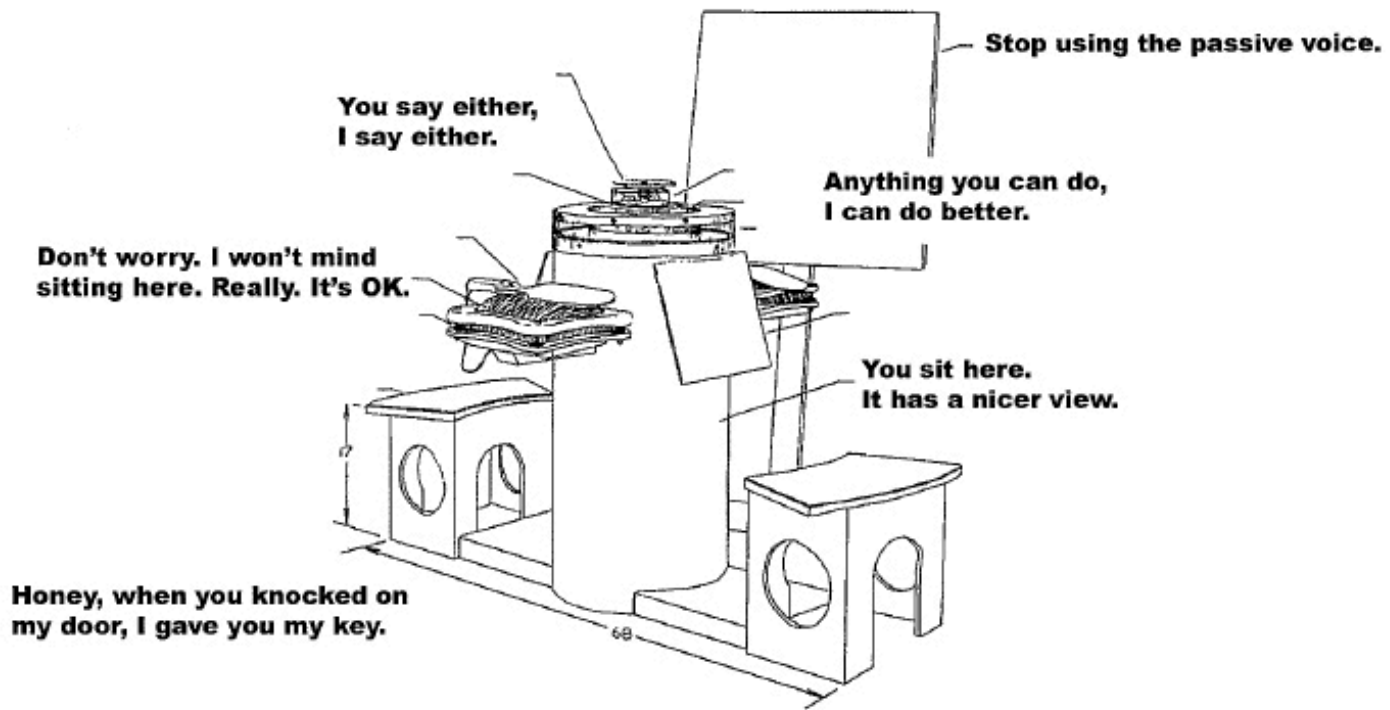

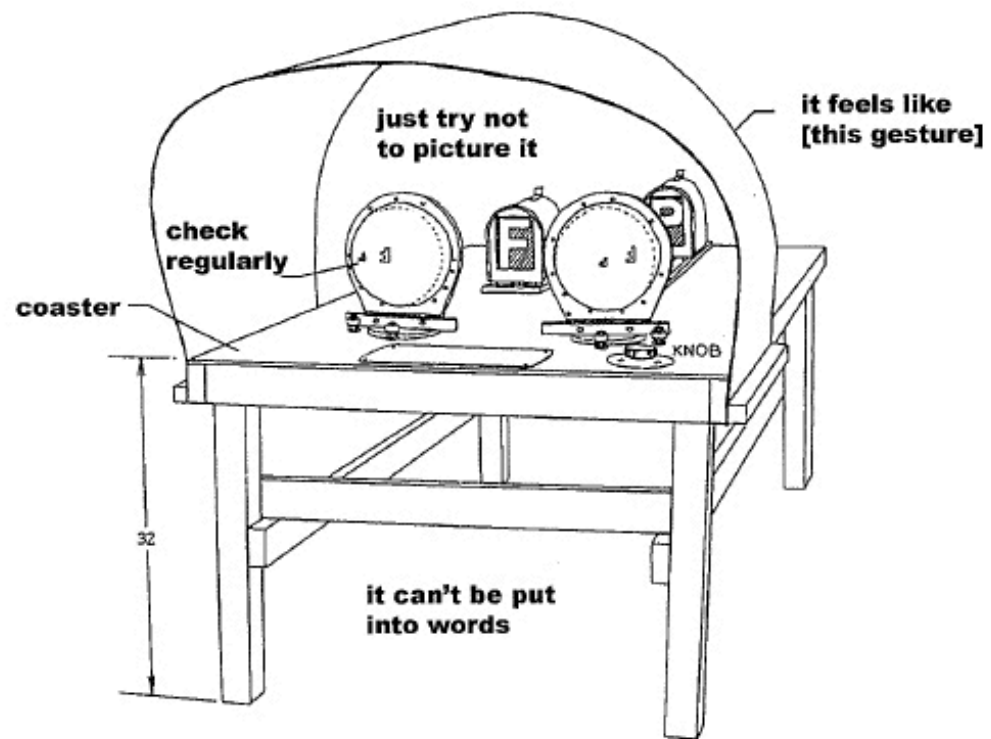

1. If by land
2. If by sea
3. Faster
4. We're not there yet

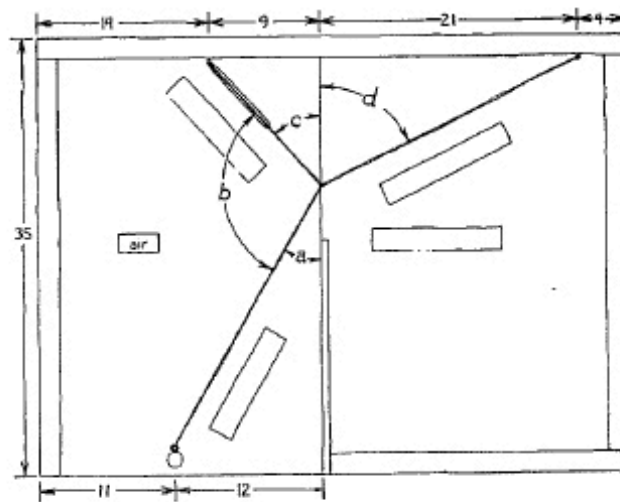

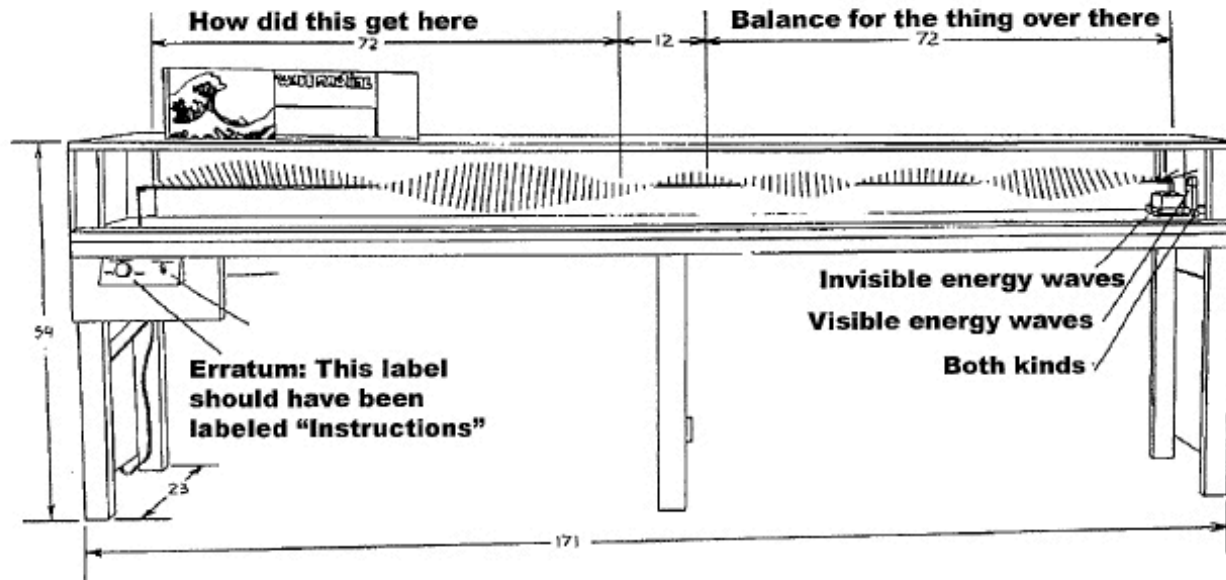

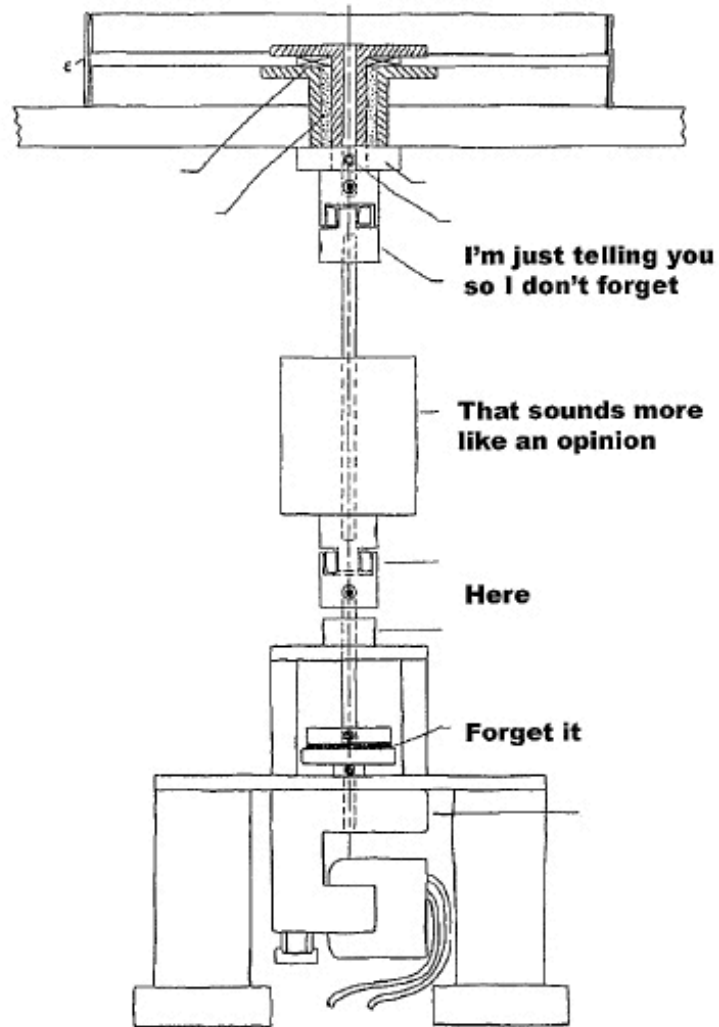

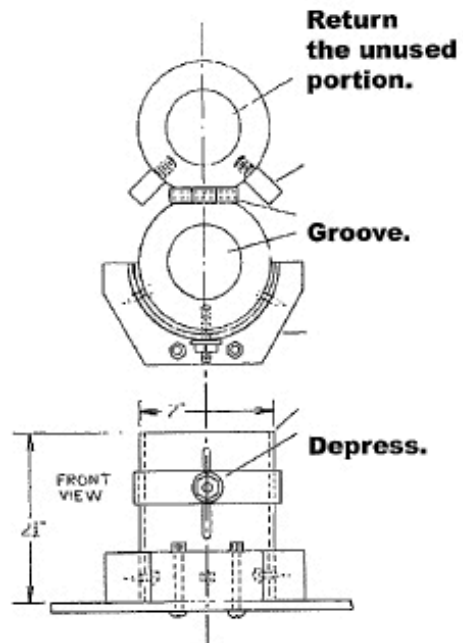

I wonder what will happen next.

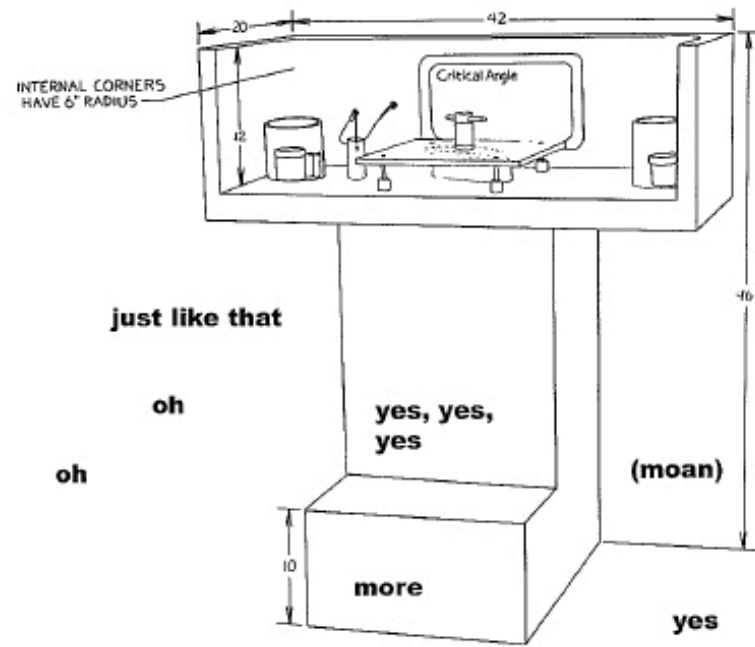

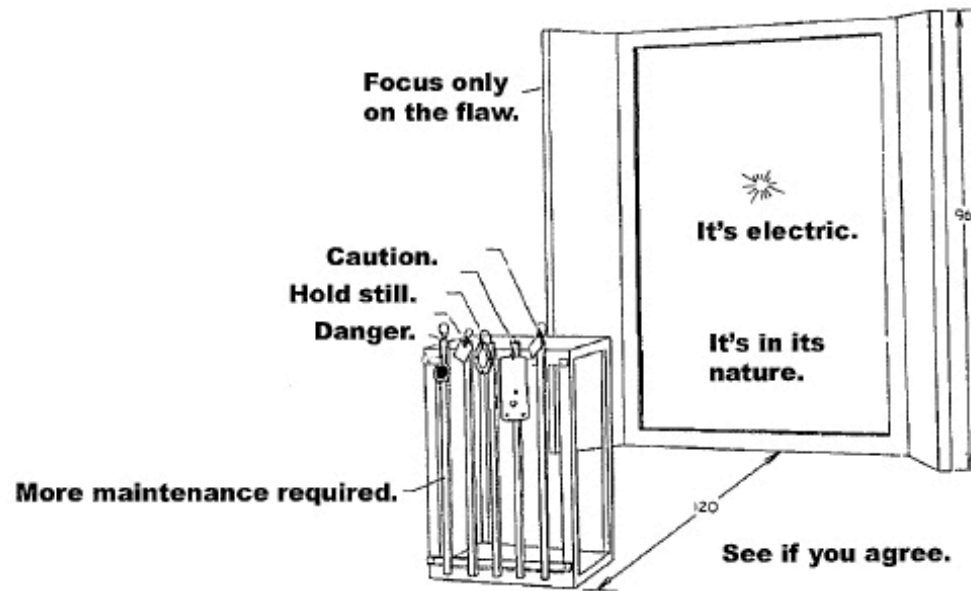

Do not hesitate.

**Keep work area
free of clutter.**

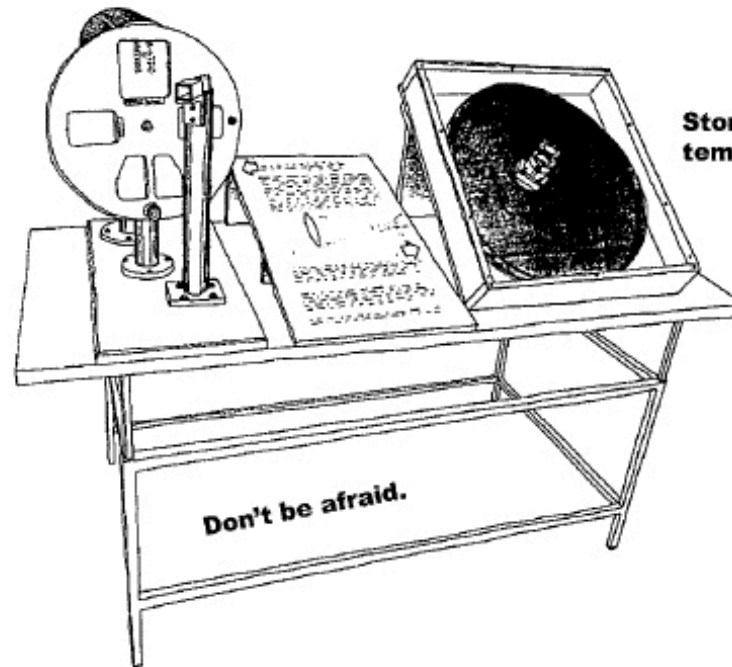

**Store at room
temperature.**

Don't be afraid.

**It takes time
to get to know.**

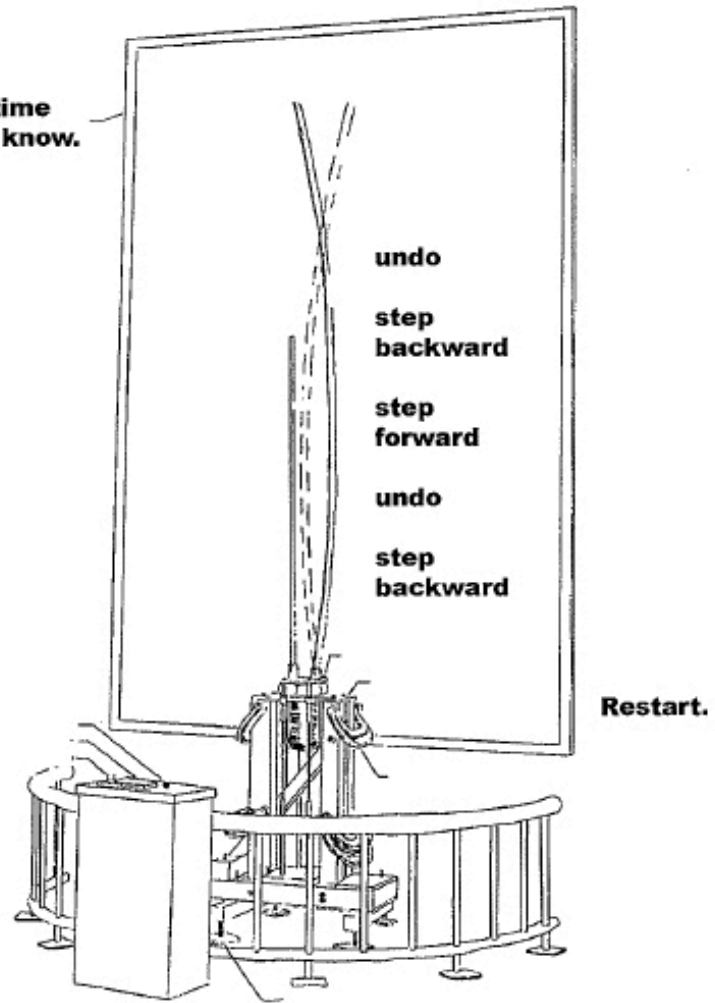

BIOGRAPHIES

Jessy Randall and Daniel M. Shapiro are the co-authors of *Interruptions: Collaborative Poems* (Pecan Grove, 2011). Jessy is a librarian at Colorado College and her website is <http://personalwebs.coloradocollege.edu/~jrandall/>. Dan is a teacher in Pittsburgh and his website is <http://littlemyths-dms.blogspot.com/>.