

Orton[®]



Kiln Safety Manual

Safety, Loading & Firing Practices

TABLE OF CONTENTS

| | |
|---------------------------------|----|
| Kiln Safety..... | 1 |
| Temperatures During Firing..... | 1 |
| Kiln Set Up..... | 4 |
| Loading The Kiln..... | 7 |
| Before Firing..... | 10 |
| Venting..... | 11 |
| Controllers..... | 13 |
| Other Precautions..... | 14 |
| After The Firing..... | 15 |
| Housekeeping..... | 16 |
| Making Kiln Repairs..... | 19 |
| Other Safety Tips..... | 23 |
| Review..... | 24 |

KILN SAFETY

Safety in the use and maintenance of your kiln is important for long kiln life and successful firings. Basic safety guidelines include:

1. Know your equipment. Read instruction manuals.
2. Before using, check your equipment for:
 - electrical connections
 - safety and control devices
 - kiln accessories
3. Make repairs when needed.
4. Follow proper safety instructions including:
 - wear gloves and glasses
 - unplug kiln when working on it
5. When in doubt, get help.

This booklet covers basic areas of kiln operation including:

- Temperatures in kiln during firing
- Setting up the kiln
- Loading the kiln
- Venting
- Monitoring the firing
- After the firing
- Housekeeping
- Making kiln repairs
- General safety tips

TEMPERATURES DURING FIRING

We all know the outside surface of a kiln gets hot during firing, but just how hot does it get? We did some tests to determine:

- how hot does the kiln lid handle get during firing?
- how hot does the kiln jacket (outer skin) get during firing?
- is there enough heat on the kiln lid to cause something placed on it to burn?
- how much heat comes out of the peephole when we open it to check a firing?

We also wanted to determine how the surrounding conditions affect the temperatures measured. So, we repeated the tests in a small enclosed area which approximated the closet - type space where some ceramists might store and fire their kilns. In a confined area there is less air to dilute the heat so we expected to see higher temperature readings.

Setting Up the Tests

We used a small, 22 1/2 inch diameter, 8-sided, 6400-watt hobby ceramic kiln capable of firing to cone 10. This was located in our production lab area - a large room. One shelf was placed in the center of the kiln containing Self-Supporting Cones numbers 7, 8, 9 and 10 visible through the peephole. Thermocouples were located in 9 different places in, on, or near the kiln (see illustrations for kiln set-up and thermocouple placement).

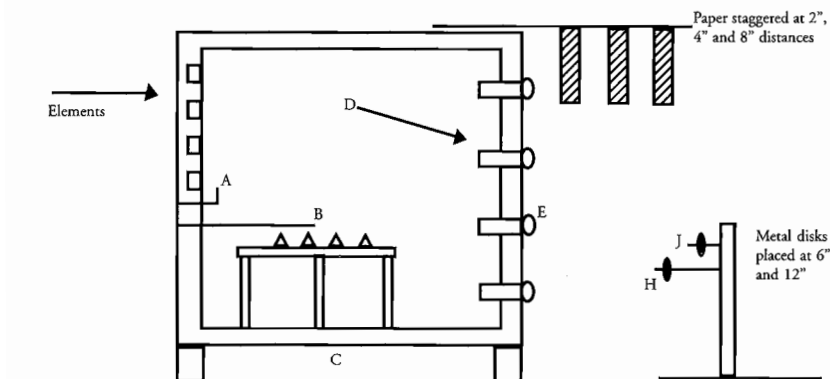

Test Results

Temperatures recorded during the tests are shown below. We identified the tests made in our production lab as "large room," and the tests made in the confined area as "small room."

| <u>Thermocouple Reference</u> | <u>Thermocouple Center Location</u> | <u>Temperature Reading</u> | |
|-------------------------------|-------------------------------------|----------------------------|---------------------|
| | | <u>Large Room</u> | <u>Small Room</u> |
| A | 1" from element | 2372 ^o F | 2365 ^o F |
| B | center of kiln | 2370 ^o F | 2365 ^o F |
| C | surface of kiln lid | 432 ^o F | 534 ^o F |
| D | surface of peephole | 644 ^o F | 705 ^o F |
| E | surface of peephole plug | 145 ^o F | 205 ^o F |
| F | kiln lid handle | 286 ^o F | 354 ^o F |
| G | exterior surface of kiln | 595 ^o F | 651 ^o F |
| H | 6" from peephole | 203 ^o F | 311 ^o F |
| J | 12" from peephole | 156 ^o F | 252 ^o F |

For comparison, some common temperatures are listed on the next page.

| | |
|------------------------------|-----------------|
| average room temperature | 68 - 70°F |
| normal body temperature | 98.6°F |
| water from hot water heater | 120°F (or less) |
| boiling point of water | 212°F |
| burning temperature of paper | 451°F |

We fired the kiln until cone 10 deformed to the six o'clock position. Then we took readings from each thermocouple location. For readings at locations H and J (steel disks), the peephole plug was removed for four minutes before the measurements were made.

Testing in a Confined Area

Tests were repeated in a small room, 7 1/2' high with 12" clearance between each of the four walls and the kiln. A small door permitted entrance to open peepholes, lift the lid, etc. For visual observation, we had a viewing port. The monitoring equipment was outside of the room and the temperature readings at points A-G were taken prior to opening the door to remove the peephole plugs and take readings H and J.

Practical Demonstrations

We placed strips of newspaper on the kiln lid along with plastic picnic forks. Strips of newsprint also were suspended from thin ceramic tubes at staggered intervals of 2", 4" and 8" from the kiln. The appearances of these items were monitored and any changes noted along with the temperatures at which the changes occurred.

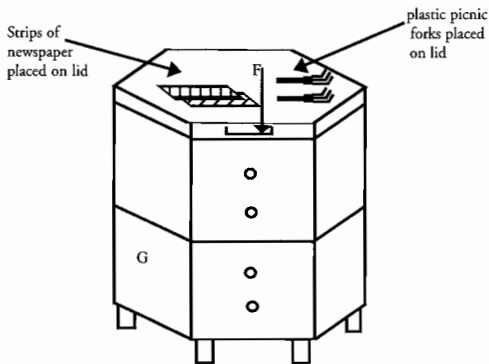

The difference in temperature between the two firings at each exterior thermocouple location was up to 108°F higher in the small room. Firing in the confined area caused the room temperature to increase from 75°F to 156°F at top temperature. This was sufficient to warp the door of the small room.

Testing also provided a visual demonstration of the high temperatures reached. Plastic picnic forks placed on the lid of the kiln at top temperature deformed severely within 90 seconds. Strips of newspaper placed on the lid of the kiln at top temperature charred. Strips of paper hung at distances of 2", 4" and 6" from the kiln became discolored from the heat, but did not burn or ignite.

Conclusions

Very high temperatures are reached in, on, and around a kiln during firings. These temperatures are high enough to do considerable damage to items placed on the kiln. The temperatures were hot enough to burn a person and highlight the importance of following proper safety precautions whenever a kiln is involved.

KILN SETUP

The Instruction Manual

After purchasing your kiln, read the kiln instruction manual thoroughly before doing any set-up or installation. If your kiln is equipped with a control system, Kiln-Sitter®, pyrometer or other device, you should carefully review these Instructions.

If you currently own a kiln and haven't looked at your kiln manual for a while, we suggest you periodically review it.

Kiln Location

Your kiln should be located in a well-ventilated, covered and protected area. A garage, basement, utility room or specially designed hobby ceramic room is the ideal location. A kiln placed in an unheated or uncooled building such as a storage shed may heat more rapidly and cool more slowly in the summer, and operate conversely in the winter, especially if cold air blows across the kiln surface.

No kiln should be located where it is directly exposed to precipitation. Water can condense on the electrical contacts causing corrosion. Eventually, this can lead to overheating, power failure or an electrical hazard. In addition, the metal surface of the kiln will rust with prolonged exposure to moisture.

Never place the kiln under a hanging obstruction like a shelf, drapes, curtains or plastic, or in a room where flammable or combustible Liquids or sprays are stored or used. These are potential fire hazards.

The kiln should be positioned on a level surface that will not be damaged by heat. A masonry or concrete floor is recommended, but other protective material may be used. Avoid placing the kiln directly on rubber tile, linoleum, wood, or any surface that might tend to mar or discolor when heated.

Our tests showed the temperature of a small object 6" from the kiln can reach over 300 F at Cone 10. For your safety, most kiln manufacturers recommend a minimum 12" of clearance be provided between the kiln and the closest wall. Be sure to allow adequate space to get in and around the kiln for loading, unloading and housekeeping. Kilns with vent systems should be treated no differently than kilns without them.

Assembling the Kiln

When moving the kiln, use the handles and have enough help to do the job to avoid strain or injury. If the kiln room floor is not level, place shims under the kiln stand feet. Do not place the shims between the kiln and the stand as this can make the kiln unstable (See illustration). Only substitute the kiln stand with one approved by the kiln manufacturer.

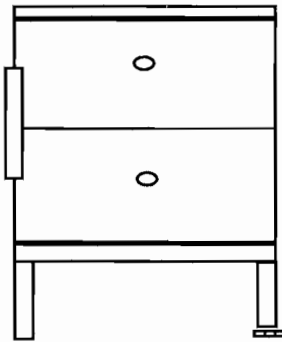

to level the kiln, place shims under kiln stand

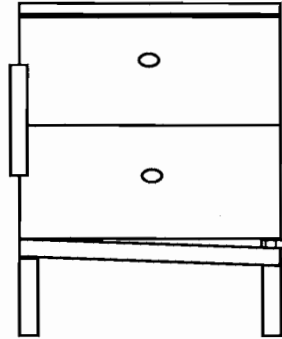

do not place shims between kiln and kiln stand

Electrical Installation

Have a qualified, licensed electrician check your electrical outlet to make sure it supplies enough power with the correct voltage. The electrician can perform any required wiring and make sure the kiln is properly grounded. The electrician should not make any alterations to the kiln without first checking with the kiln manufacturer. Unauthorized changes to the kiln or its parts could void the kiln warranty and UL or CSA ratings.

Before plugging in the kiln, turn off all switches. Make sure the wall receptacle is not corroded or damaged. Check the kiln's power supply cord and plug to make sure they are unaltered and in good condition. A damaged plug, receptacle or cord may cause arcing and is a potential fire hazard.

NEVER use an extension cord to run your kiln. If the kiln cord is not long enough, relocate the kiln or the electrical outlet.

Avoid running the kiln's power supply cord close to the side of the kiln. If necessary, loop or hang the power cord securely overhead and out of the way. Our tests showed the outer jacket of the kiln can reach temperatures over 650 F at cone 10. This is hot enough to eventually melt or burn away the protective covering on the cord exposing the live wires inside. To avoid overloading the outlet make sure the kiln is on its own circuit.

The Importance of Test Firing

Most kiln manufacturers recommend an initial test firing prior to using the kiln. This firing properly seats the kiln elements, determines its performance characteristics, and familiarizes you with how your kiln fires.

During the test firing, observe good ventilation practices so excess moisture is removed from the kiln and kiln elements are properly oxidized. Make sure the electrical connections remain cool and operate properly. Generally, a test firing is done to a cone number recommended by the manufacturer. Check the kiln manual for complete instructions.

Some manufacturers suggest a second firing to cone 06-05 with the kiln furniture in place to prevent future shelf cracking. Again, follow the kiln manual instructions.

LOADING THE KILN

Before Loading

To prevent accidentally powering up the kiln and attached devices during loading, all kiln switches and attached device switches, including automatic venting systems and control systems, should be turned off. If you have an attached lid, lock the lid support into place before loading the kiln.

Be sure to vacuum inside the kiln before each use. Flaked pieces from elements and dust may contaminate your ware. Visualize how you will load the kiln before you start to prevent rearranging pieces later on. For better heat distribution, place larger pieces near the center and smaller pieces at the outer edge of the kiln shelves.

The Kiln-Sitter®

Before loading the Kiln-Sitter®, test the sensing rod according to the instructions in the Kiln-Sitter® manual for free centered motion. Apply a thin coat of kiln wash to the cone supports and sensing rod, but do not place kiln wash or any other foreign substance on the cone or bar. When using kiln wash, do not allow it to build up on metallic parts - if necessary, clean or scrape off the old kiln wash before applying a new coat.

Before placing shelves and ware in the kiln, load the Kiln-Sitter® with your firing cone or bar. Once the kiln is loaded, you may not be able to reach the Kiln-Sitter® without unloading. Be careful not to disturb the Kiln-Sitter® or dislodge the cone or bar during loading. Do not depress the Kiln-Sitter® plunger until all loading is complete and you are ready to begin the firing.

Shelves and Supports

Select only clean shelves in good condition. Do not use cracked shelves as they may break during firing. Be sure the shelf bottoms are clean to prevent dust or dirt falling onto the ware below.

Apply kiln wash to the tops of kiln shelves to prevent your ware from sticking. Use the proper kiln wash rating - high fire or regular - for your kiln and the ware you are firing. Never apply kiln wash to the undersides or edges of shelves as it may drop onto the ware below. Kiln wash should not be applied to kiln walls or come into contact with kiln elements.

All kiln shelves and ware should be at least 1" away from the Kiln-Sitter® cone supports and sensing rod, and at least 1" from the top and bottom of the Kiln-Sitter® refractory tube. Both shelves and ware will expand when heated and shelves may shift slightly. Ware or shelves placed too close to the Kiln-Sitter®, may interfere with its proper operation and produce an overfiring.

To permit air circulation and even heating, use posts under each shelf. The bottom shelf should be placed on 1" posts above the kiln floor. Using three posts at the desired height will provide the most stable support. Set posts to form a triangle about 2" in from the shelf's outer edge making sure the shelf is level, balanced and sturdy. Position the posts over one another on each level to evenly transfer load weight down through the posts.

Avoid using posts taller than 10"; they may be unstable. If necessary, place tall objects on the top shelf. Posts may be stacked, but are less stable than a single post of equivalent height. To allow ware to expand, make sure all posts are at least 1" taller than the tallest ware on the shelf.

When positioning shelves, stack them so there is at least one row of elements between any two shelves to insure heat reaches the ware and the underside of each shelf. Be careful during loading to avoid knocking against the firebrick walls with shelves, posts, ware or other objects. This may cause chipping or dusting from the walls.

Stilts

If you stilt earthenware pieces, be sure to select stilts with adequate support for the ware during firing. If you are firing porcelain or stone-ware greenware, dry foot the ware instead of using stilts. Stilts will embed in the ware during firing.

Loading the Ware

Make sure all ware is kept at least 1" from the element coils to prevent ware from becoming warped or distorted. Since kiln shelves are cooler than ware during firing, it is important to minimize direct contact between the shelf and ware. Large flat pieces may warp because the top may be hotter than the bottom, which is in direct contact with the cooler shelf.

To prevent greenware from exploding during heat up, be sure it is dry before making your bisque firing. Many modern kilns with controllers make it possible to use the kiln for drying. When doing this, set a very slow heating rate on the controller or turn your kiln switch to a low setting and be sure to vent properly .

For proper oxidation, make sure air can circulate around the greenware. Avoid stacking pieces if possible. If you must stack ware, do not place heavy pieces on smaller ones or the small ones may warp, crack or break under the weight.

When firing glazed pieces, allow at least 1/2" between other pieces, kiln walls, and kiln shelves. Lusters should be spaced 1" apart to avoid contamination.

Witness Cones

Place Large or Self-Supporting Cones on each shelf with the ware as you are loading. Position the cones so they can be viewed from the peepholes, but away from any peephole draft. If you are using homemade cone pats for the Large Cones, make sure the pats are dry before placing them in the kiln or they may explode during firing.

Be careful to set cones in homemade pats at 8° from the vertical and 1-3/4" high above the pat base (large cones). Mounting angle and height will affect cone bending if not done uniformly each time. Self-Supporting Cones have a built-in base and can be used as is.

Thermocouples

When using instrumentation, insert the thermocouple carefully into the kiln making sure the thermocouple tip is not damaged. If the bead on the tip of the thermocouple is broken or damaged, the instrument may not function or may give incorrect readings.

Take care in the selection and use of thermocouples used with electronic controllers and pyrometers. Thermocouple wires are welded (or twisted) together at one end.

As the bead heats, an electronic signal measures temperature. The best thermocouples are platinum and platinum alloys (usually Type S). However, Type K is the most common thermocouple used. It may be provided as an 8-gauge (thick) wire or a 14-gauge (thinner) wire. Sometimes the thermocouple is inside a metal or ceramic tube. Type K thermocouples oxidize when heated and form a protective coating on the metal, lowering thermocouple output. Higher temperatures lead to faster wire oxidation. In one test, 8-gauge wire was oxidized nearly through when heated at 2200°F for 300 hours. The maximum recommended operating temperature for a 14-gauge wire is 2000°F (cone 02) and for 8-gauge is 2300°F (cone 9).

BEFORE FIRING

Once the kiln is loaded, carefully lower the lid. If the kiln is jarred as you close the lid, open the kiln and check to make sure nothing moved or fell over. If necessary, unload and reload the kiln.

For manual kilns, set switches according to the kiln manual instructions. Start with switches on low settings. A slow heat-up time allows organics in your ware to bum out. It also helps to equalize heat distribution within the kiln.

Kiln ventilation is very important for good firing results. If you are not using a downdraft vent, prop the lid approximately 2" and remove all peephole plugs. If you have an automatic kiln venting system, follow the manufacturer instructions.

Make sure nothing will obstruct the Kiln-Sitter® weight falling freely at shut-off. Set any timing devices for 15-30 minutes longer than the expected firing time. Depress the plunger to activate the Kiln-Sitter®. Start any automatic control device according to manufacturer instructions. If you have any doubts - DO NOT FIRE.

Kiln Loading Reminders

1. Stack shelves so at least one row of elements is between any two shelves.
2. Keep shelves 1" from element coils and at least 1" from kiln Sitter®.
3. Avoid using posts taller than 10"
4. The bottom shelf should be on posts at least 1" from the kiln bottom
5. Using 3 posts positioned over one another on each shelf provides the most support.
6. Place sets of cones on each shelf in kiln positioned to be viewed through the peephole.

VENTING

Kiln venting is important for proper firing and for your health and safety. Kiln manufacturers always recommend firing with adequate ventilation, especially during early stages of firing.

Venting provides oxygen the ware needs during most product firings. Oxygen helps develop color, texture and a variety of other properties. Most ceramic and glass products are specifically formulated to be fired in an air atmosphere.

Additionally, venting removes fumes developed during firing. Fumes can pose a health hazard when released into the kiln room. Additionally, a downdraft ventilation system can improve temperature uniformity within the kiln and assist in post-firing cool down.

Methods of Venting

Natural Venting Most kiln manufacturers suggest propping the kiln lid for the first two hours of firing and leaving the top peephole open throughout the firing.

This method has several drawbacks:

- sufficient air may not enter kiln
- fumes and odors are released into the kiln room
- temperature distribution decreases as cold air enters the kiln

Room Ventilation Through-the-wall exhaust fans help draw fumes and odors outside, but they do not improve internal kiln conditions. They do not provide air for the kiln, nor do they help temperature uniformity. Also:

- lots of make-up air is required
- fumes are released into the kiln room

Above The Kiln Ventilation

As fumes rise, they are pulled into the hood vent above the kiln. Problems with these systems include:

- some fumes will usually enter the kiln room
- firing conditions are not improved
- lots of make-up air may be required
- installation and use may be awkward

Orton's Downdraft Ventilation

Downdraft ventilation, like the Orton patented system, draws a small amount of air into and down through the kiln, collecting fumes and *odors*, while improving firing conditions in the kiln. Downdraft vents will:

- even out top to bottom temperature
- provide air/oxygen needed
- virtually eliminate odors
- reduce heating elements/Kiln-Sitter® maintenance
- shorten cool down time
- eliminate gases escaping through peepholes or kiln lid

Orton downdraft systems are easy to install and fit most electric kilns.

How it Works

1. small holes in kiln lid permit air entry
2. air is drawn into kiln and distributed throughout kiln
3. fumes and odors leave the kiln through holes in the bottom of the kiln
4. collected fumes and odors are mixed with room air and pulled through vent chamber by blower
5. air and fumes are expelled through flexible aluminum ducting
6. air can be vented outdoors through residential dryer ducting

No gases escape through the peepholes or kiln lid - fumes never enter kiln room!

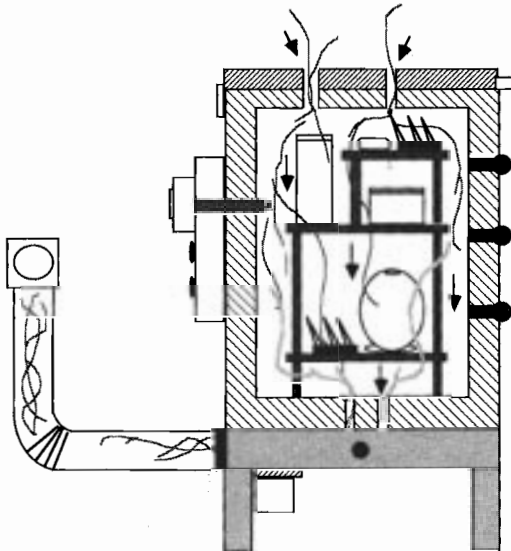

MONITORING THE FIRING

Kiln Safety For Controllers

Most new kilns are purchased with an electronic controller instead of a Kiln-Sitter® and switches. Controllers can provide for consistent heat-up and cool-down of the kiln. When used with downdraft venting, the kiln firing requires very little attention. Controllers can be programmed to turn on the kiln at a convenient time and allow the kiln to be soaked at a specific temperature, which is important for some of the new lead-free products used today. They also allow you to control the proper firing and cooling of crystalline glazes.

Most controllers include the same basic features, but there are often differences in how well the controller works. A controller can't make the kiln do something the kiln is not capable of doing, such as firing faster or cooling more quickly. However, controllers, such as Orton's UniTemp, will fire the kiln more uniformly. This is done by controlling the power to individual heating elements and using intelligent software in the controller. Most controllers sold today have preset programs that allow you to fire to a cone number using a patented method developed by Orton to compensate for changes in firing conditions.

What Affects Controller Performance

Controllers depend on a signal from the thermocouple. As described earlier, if this sensor changes over time (such as occurs with Type K thermocouples) then the controller will not heat the kiln to the desired temperature. If the thermocouple bead is placed next to a heating element or in a draft, it may provide an incorrect signal. If the thermocouple is thicker, the temperature at the controller may be incorrect because it takes longer to heat up and the thick wire draws heat away from the measuring bead.

Is My Controller Working Correctly?

Check the kiln by using witness cones located on the shelf near the ware. Cones will give you a consistent measurement of whether the kiln is firing to the correct temperature. If not, then change the thermocouple or adjust the firing temperature to add more or less heat to the kiln. Usually, when Type K thermocouples drift, less heat is needed in the kiln. Some controllers allow you to make a permanent adjustment when firing to a cone number.

Why Ventilate

Poor ventilation creates an unhealthy working environment. It also can cause a variety of finished ware defects. The most common defects are in the texture, surface appearance, and particularly in glaze color, luster or decal.

With the Orton downdraft vent, you can fire red, green, yellow and blue glazes together and obtain true colors. Dullness in decals is eliminated. With lusters, odors do not enter the room.

If sufficient air is not provided when earthenware is bisque fired, a grayish inner area is frequently observed, where carbon has not burned out. Residual carbon can produce pinholes, pits, craters or blisters once the piece is glazed and refired. Porcelain ware also may blister or bloat.

Sulfur containing gases from the clay can cause dull or scummy finishes as well as gray-looking reds and cloudy golds and platinums.

Additionally, glaze migration can occur when metals volatilize off one glazed surface and redeposit on another. A small amount of air flow can eliminate this problem.

OTHER PRECAUTIONS

Kilns should be checked periodically during firing to make sure everything is working as expected. Never leave a kiln unattended while firing. It takes only minutes for a dangerous situation to develop. Keep a properly rated fire extinguisher in the kiln room in case of emergency and keep children out of the kiln room or make sure they are closely supervised.

Do not use the kiln for other than its intended purpose. It is not an oven or a clothes dryer. It is not meant to warm your lunch or dry wet mittens. Do not use the kiln for salt or reduction firings unless it has specifically been designed for this use.

Consider how time affects objects subjected to even a low temperature. An article by John M. Watts in the June 1987 issue of Studio Potter magazine explains that wood, which has a normal ignition Temperature of 400 – 500°F, has been found to ignite when subjected to a heat source of 228°F for four days. Even though you are firing to a low temperature, a hazardous situation may develop over time.

Objects with a low melting point, such as plastic bags, rubber bands or plastic wrap also should be kept off of the kiln lid. They may not catch on fire, but they can create a mess on your kiln lid if they melt and stick.

Electrical

During the firing, gingerly check the kiln plug and cord to see if they are hot. If they feel warm, terminate the firing and have an electrician come and check your wiring.

Be on the lookout for sparks. Sparks can occur if kiln elements are not tightly connected. Sparks also may occur at the switch box. If you see any sparks, cease firing immediately and have your kiln and wiring checked before firing again.

AFTER THE FIRING

As soon as the Kiln-Sitter® or your electronic controller turns off the kiln, manually turn the switches to the off position to cut power to the kiln. Do not open the kiln lid until the kiln has cooled. A good rule of thumb is cooling will usually take twice as long as the firing. Be sure to lock the lid support into place before unloading.

When removing ware from the kiln, be careful of sharp edges which have resulted from stilting. These stilt marks should be carefully ground down to prevent cuts before pieces are used or returned to their owners. Save fired cone sets for comparison against previously fired sets and be sure to record your results. Good records are important for consistent results.

HOUSEKEEPING

Routine housekeeping tasks are important to keep your kiln running safely and efficiently. Most preventive maintenance chores are fairly simple to perform, and can help you catch and correct problems and avoid serious mishaps during firing.

Before doing any work on your kiln, turn all switches to off and unplug the power cord from the wall. If you will be working inside the kiln, lock the lid support into place.

Inside the Kiln

Vacuum inside the kiln before each firing to remove loose bits of firebrick dust, flakes off the elements and any other material which has accumulated. During firing there is considerable air movement inside a kiln. Dust and dirt which settles on your ware can ruin it . If you have ever seen black spots on your red glazed ware, a dirty kiln may have been the culprit.

Use a soft attachment when vacuuming inside the kiln to prevent damage to the firebrick. Be sure not to touch the cold kiln elements with the vacuum nozzle. Cold elements are *very* brittle and break easily.

Before each firing, check the kiln walls and floor for glaze spots. If you find any, use a heavy spatula or flat-bladed screwdriver to remove them. Glaze spots that are not removed may re-melt when you next fire and drip onto the kiln elements or your ware. Be careful not to damage the wall or floor when cleaning up these drips and splatters.

Look over all the elements to make sure they are tightly coiled inside the element grooves and in good condition. Note any problems you see so they can be attended to before your next firing.

Kiln Furniture

Vacuum both the top and bottom surfaces of your shelves to remove accumulated kiln wash and dust. Carefully examine the shelves for glaze drips or spatters which might re-melt and damage your kiln or ware when you next fire.

Small drips can be removed using a hammer and chisel or a hand grinder. Observe all safety precautions during the cleaning process due to the danger of flying glaze chips.

For large spots, or where glaze is actually fused to the kiln shelf, it may not be possible to remove the glaze safely. This is most likely to occur if you have a serious overfiring, if a pot falls over in the kiln, when dry footing is done improperly or if kiln wash is not used. When this happens, it is best to simply discard the shelf.

When cleaning off small drips, use a protective face shield to guard against injury to your face and eyes. Place the chisel at about a 30° angle and gently tap on the end of it with the hammer to chip away at the glaze spot. Do not use a screwdriver as a chisel. If you are using a hand grinder, follow the instructions for safe and proper operation provided with the equipment.

After cleaning off the glaze drips, vacuum the shelves again and examine them for cracks. Set aside cracked or broken shelves for disposal. Recoat cleaned shelves with a thin layer of kiln wash in preparation for their next use.

The Kiln-Sitter®

Before each firing, check the Kiln-Sitter® sensing rod for free and centered travel. The rod also should be checked periodically to make sure it has not deteriorated and is not bent. Cone supports also should be checked. If any damage is noted, both the cone supports and the sensing rod should be replaced. Damage of this type is most likely to occur when firing stoneware or porcelain because of the high temperatures reached.

Every 20 firings (or every month if you fire less), the Kiln-Sitter® should be tested and adjusted. The force of the weight dropping down and the effects of corrosion and heat can change the adjustment of the claw-trigger assembly and affect when the kiln shuts off. Routine checks are important to insure the heat treatment and results you want. Tests and checks will help prevent a disastrous overfiring.

Follow the instructions in the Kiln-Sitter® manual and use the firing gauge (See illustration following page). included with the kiln to make your tests and adjustments.

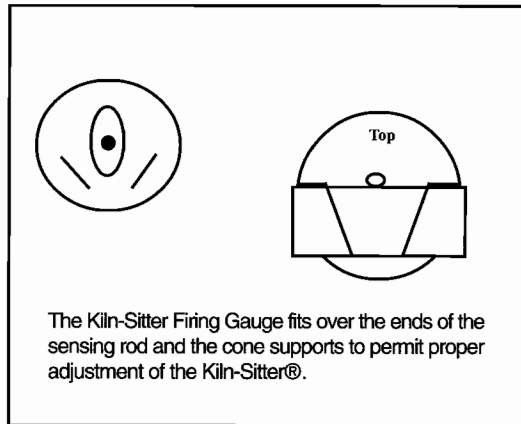

Never use lubricants of any kind on the Kiln-Sitter®. If you have problems adjusting the kiln- sitter® or with its operation, have the unit serviced by a qualified kiln repair person.

Outside the Kiln

Keep the outside of the kiln clean to prevent pitting, rust or other damage to the kiln jacket. Clean the surface with glass cleaner to keep it shiny. To remove discoloration, use a stainless steel cleaner. Be careful not to spray cleaner on the electrical switch box or the Kiln-Sitter® box, Avoid spraying cleaner inside the kiln.

Plugs and Cords

Carefully examine the kiln plug and cord to make sure they are in good condition. Look for fraying, tears or cuts in the cord covering and be sure the plug is well-attached to the cord. Minor surface cuts in the insulation can be repaired with electrical tape, but if severe cuts, frays or damage to the wires are found, the plug and cord set should be replaced by a qualified electrician or kiln repair person using only an exact manufacturer's replacement. NEVER pull a plug from the wall by yanking on the cord. Remember, damaged or improperly maintained electrical equipment can result in electrical shock or fire hazards.

MAKING KILN REPAIRS SAFELY

Before beginning any work on your kiln, be sure to turn the kiln off and unplug it from the wall. Read all instructions in your kiln manual on performing the required service work. If you are not mechanically inclined, it is best to consult an authorized kiln repair person to make the needed repairs.

If you choose to make the necessary repairs yourself, you may still have a qualified service person check your work, especially electrical maintenance. Incorrect wiring can create a life threatening situation and may invalidate your kiln warranty. A licensed electrician or small appliance repair person should be able to correctly perform the work. Be sure to provide your kiln owner's manual to the service provider.

The Troubleshooting and Maintenance sections of your kiln manual may help you determine a problem with your kiln. You may find your problem is easily remedied (for instance, a timer which was not set on the Kiln-Sitter®, or a kiln that needs plugged in) and you do not need professional assistance.

Transporting the Kiln

If you have to transport your kiln for service, carefully move your kiln using the handles. This may require an assistant.

Place the kiln on a flat, stable surface in the transport vehicle. Use blankets or some other protective material to cushion the kiln. Be sure the kiln is immobilized during transport.

When replacing the kiln on the stand after maintenance work or service, be sure the kiln is level and stable and any shims are properly reset.

Floor Repairs

The kiln floor can be patched using a commercially available ceramic cement or a stiff putty made of high-fire kiln wash and water. Undercut the edges of the area to be filled and tamp the putty or cement into place. Scrape the patch so it is smooth and level with the surface of the kiln floor. Let the patch dry thoroughly before firing.

If the floor condition gets too bad, check your kiln manual to see if your kiln floor can be inverted and the bottom side used.

Lid Repairs

Hairline cracks in the kiln lid are a normal occurrence. They naturally result from the expansion and contraction of the lid during firing and cooling and generally do not require repair. In the case of a hole or gouge, smooth the interior with sandpaper to prevent further deterioration. It is not necessary to fill the hole. If the lid condition gets too bad, you may be able to flip it over and use the other side. Consult your kiln manual for information and instructions on how to do this.

Repairing Kiln Walls

Patching kiln walls is a job most ceramists do themselves. While you do not have to be concerned with normal hairline cracks in the walls, holes should be patched with repair cement to prevent them from getting larger. After the spots have dried, smooth them with sandpaper and vacuum your kiln to remove any dust which resulted from the repairs. When filling in holes, be careful not to contaminate the kiln elements or they may break or burn out when you next fire.

Replacing Insulating Brick

Replacing insulating bricks is considered a last resort operation. It should only be done if the hole is too big to repair or if it causes your kiln elements to become loose or unsecured.

If you attempt to replace the insulating brick yourself, be sure to carefully follow the kiln manufacturer's instructions for handling and working around the kiln elements. Cold elements are brittle and can be damaged easily.

Replacing terminal bricks (located where the element ends go into the switch box) involves cutting and and resecuring the elements. If possible, these bricks should not be replaced until the elements are replaced.

Kiln Case Repairs

On some kilns, the case or kiln jacket clamps may need periodic tightening. Refer to your kiln manual for specific instructions on how to tighten the "worm" screws on the back of the kiln case.

After repeated firings, it also may be necessary to tighten the lid band due to expansion and contraction of the lid brick. The lid handle also may come loose and need repositioning and tightening.

Kiln Elements

New kiln elements have a metallic look and are very flexible. In fact, they look like a very long, tightly wound spring. However, once they are fired, the elements take on a duller, dark look and may appear coated and flakey. Elements also become very brittle and will break if they are bent or handled when they are cold.

After repeated firings, elements may have a tendency to lose their “coil memory” and get longer. If they are unsupported due to missing element pins or chipped element grooves, the elements will sag and eventually start to stretch or unwind. Proper maintenance is important to prevent this problem.

Straightening Kiln Elements

Straightening sagging elements is not a difficult task. However, because it is potentially very dangerous, we recommend you do not perform this repair yourself. You could be severely burned or electrocuted during this repair.

Our tests show kiln elements must reach a temperature of 1500 - 1600 °F before they are pliable enough to straighten. That is 1300 ° hotter than the boiling point of water!

Where elements can be pinned into place without being heated, you should be able to follow the kiln manufacturer's instructions and do this yourself. Just be sure not to staple or fasten elements in kilns used above cone 05. This will create a hot spot at the point of contact between the elements and the fastener and will reduce element life.

Replacing Kiln Elements

If one section of the kiln does not get hot, or as hot as expected, or if your firing seems to take excessive time, you may have a burned out or broken kiln element. In addition, badly uncoiled elements should be replaced if they cannot be straightened and replaced into the element grooves.

While most kiln elements are not difficult to replace, you do need electrical connector tools and a good working knowledge of wiring and electricity to do the job properly. If you are unsure of the correct tools to use, or exactly how to do the job yourself, it is best to have the work done by a professional service person.

If you decide to replace the kiln elements yourself, turn the kiln off and unplug it before you start. Carefully follow the instructions provided by the kiln manufacturer. Be sure to use only factory approved parts. (Factory approved parts should be used whenever replacement parts are needed such as for kiln stands, peephole plugs, switch knobs, etc.).

Some kilns use different elements for different sections of the kiln, so you may need to consult your kiln distributor or manufacturer to be sure get the correct part(s). For some kilns, it is best to replace all the elements since new elements will heat to higher temperatures than older ones. This will affect the heating uniformity of your kiln. Check your kiln manual to see if your kiln's manufacturer recommends replacing one or all of the elements.

If you have any questions or doubts after making the repair, have a kiln service person check your work before you turn on the kiln. You should also refer to your kiln manual for instructions on breaking in the new elements prior to firing a load of ware.

For emergencies, you may wish to keep an extra set of elements on hand to reduce your down time if an element does burn out or break. You may also wish to keep other spare parts around such as a Kiln-Sitter® sensing rod and cone supports, or an extra thermocouple.

Electrical Repairs

Short circuits in the kiln, blown fuses and repeated overloading of circuit breakers signal serious electrical problems. These should be handled by a qualified electrician, kiln repair person or small appliance repair person to insure work is done correctly and to code.

Other problems requiring professional service include kiln switch box or switch box connection problems, a defective or hot wall receptacle or kiln plug, or a wall receptacle which does not match the kiln plug. Never cut the plug off of the kiln cord and replace it with another as you risk electrical shorts or a fire.

Kiln-Sitter Repairs

The Kiln-Sitter® is an electrical and a mechanical piece of equipment. Generally, mechanical problems can be fixed by using a testing gauge to adjust the trigger and claw assembly, or by replacing a bent or corroded sensing rod and cone supports.

However, if something electrical goes wrong with the Kiln-Sitter®, if the mechanical problem is not remedied by your repairs, or if you are unsure of the cause of your Kiln-Sitter® problems, it is best to have a kiln service person take a look at the device. The Kiln-Sitter® plays a vital role in kiln shut-off and you cannot afford to take chances on improper or incomplete repairs.

Whenever you have Kiln-Sitter® problems, be sure to use witness cones on the kiln shelf and fire visually until the cause of your problems is located and resolved. This way you can avoid potential overfirings, loss of ware and damage to your kiln.

Many professionals use at least one witness cone at all times to act as a back-up should the firing take too long. Because this cone is located on the shelf along with the ware, it also tells the ceramist the actual heat treatment the ware received.

OTHER SAFETY TIPS

In addition to required maintenance, periodic service checks and routine housekeeping chores should be performed on the kiln to catch potential problems and insure the kiln continues to operate safely and correctly. Because a kiln reaches very high temperatures during firing, there is always a risk of personal injury or fires.

To insure your safety, you should equip the kiln room with a smoke alarm, be alert and periodically check the kiln and the cones throughout the entire firing. Firing the kiln unattended, such as firing overnight, is not recommended. Always be sure all shut off devices have operated properly and after the firing is terminated, manually turn all switches to off.

A REVIEW

To help control and stop preventable accidents, it is vital to incorporate the safety precautions discussed in this booklet into your regular firing routine. Here is a review of the most important steps you should follow:

- 1. Know your equipment**
 - read all installation and operating instructions and refer to them frequently.
- 2. Check your equipment before each use**
 - carefully examine electrical connections, safety and control devices, shut-off devices, lid props etc, to make sure they are serviceable.
- 3. Maintain your equipment in good working order**
 - make any repairs as needed
 - don't wait until "next time".
- 4. Have service checks and repairs performed regularly by an authorized service person**
 - check your kiln instruction manual for manufacturer's recommendations.
- 5. Be aware of proper safety precautions and follow them**
 - use safety devices such as goggles and gloves.
- 6. Firing any kiln unattended or unsupervised is not recommended.**
- 7. Be sure any personnel who operate the kiln have read and understand the instruction manual**
 - operators should be fully trained in the kiln's safe operation and know how to react should an accident or emergency occur.
- 8. When in doubt, do not fire**

Notes

The Edward Orton Jr. Ceramic Foundation's roots go back to the establishment of the Standard Pyrometric Cone Company in 1896 by General Edward Orton Jr. Today the Orton Ceramic Foundation is dedicated to providing products to industries involved with heat processing and the measurement of material properties and to the pursuit of advancing the knowledge and know-how for heat processing.

6991 Old 3C Highway - Westerville, OH 43082 - 614/895-2663
website: www.ortonceramic.com