

ARMOGEAR

NESSTOY
Imported by
KIDZLANE LLC

8+
AGE

LASER BATTLE

INFRARED LASER TAG GAMING SET
WITH BUILT IN NIGHT VISION LED

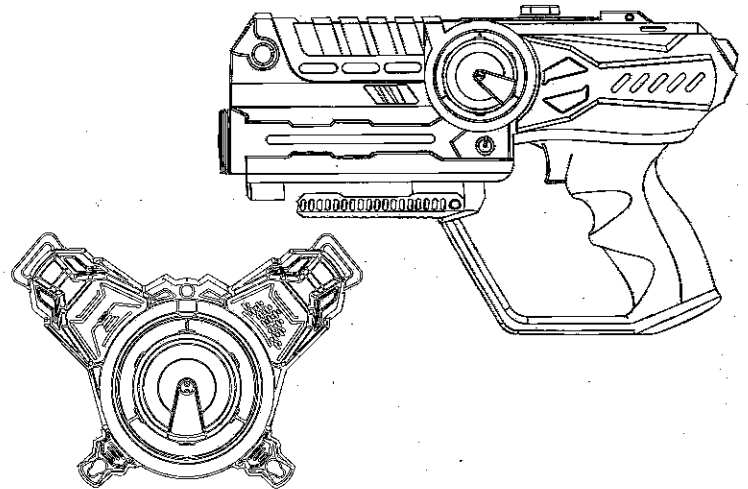

OWNER'S MANUAL

Item #2904

Thank you for purchasing the ArmoGear Laser Battle System!
Get ready to have a blast with this riveting action game. You'll
learn to aim, shoot and win like a true marksman!



WARNING:
CHOKING HAZARD - Small parts.
Not suitable for children under 3 years.



CONTENTS

- 4 Laser Battle Guns
- 4 Laser Battle Vests

BEFORE YOU BEGIN

- Locate the battery compartments on the back surface of the guns and vests.
- Unscrew each compartment door using a Phillips screwdriver.
- Insert 3 AAA batteries with the + and - signs pointing as indicated on unit.
- Close the covers and tighten the screws.

Caution: Batteries are to be inserted with the correct polarity. The supply terminals are not to be short-circuited.

WEARING THE VEST

- Position the vest in the center of your chest and pull the elastic strap over your head ①.
- Pull the other strap from the side around your back to the other side ②. Lock into place by pushing the plastic pin into the hole as shown ③. Then, pull pin into the notch with force until a click is heard ④. This will lock the pin in place and keep your vest securely on.



USING THE GUN (See illustration on opposite page)

- Press the ON/OFF button ① to power the laser gun on or off.
- Press the TEAM button ② consecutively to switch between RED, ORANGE, GREEN, and BLUE team.

Note: Team color does not correspond to the color of your gun. Press the WEAPON button ③ consecutively to switch between SHOTGUN, MACHINE GUN, ROCKET, and PISTOL mode. Each weapon mode includes a different amount of pre-loaded shots, and a different amount of lives taken per shot on target:

	Pistol	Shot Gun	Machine Gun	Rockets
Preloaded Shots	12	5	9	1
Lives Taken Per Shot	1	2	2	3

Note: When MACHINE GUN mode is activated you may press and hold the trigger to release a steady stream of bullets. This will last a few seconds until you need to reload.

- Press the trigger ④ to shoot.
 - Move the LIGHT switch ⑤ to ON/OFF to turn the built in flashlight on or off.
 - Move the RECEIVER switch ⑥ to ON/OFF to turn your gun's receiver on or off.
- When receiver mode is on, your gun can be used as a target by opponents. When it is turned off, only your vest can be used as a target.

- Press the RELOAD button ⑦ to reload your gun with ammunition.
- Press and hold the RELOAD button ⑦ to activate INVISIBLE mode for 15 seconds. This will turn the lights off and make your gun invisible in the dark. To achieve invisibility for your gun and vest, press and hold the RELOAD button while holding gun and vest closely together.

Note: Activating the INVISIBLE mode on your gun may also cause your other team players to become invisible.

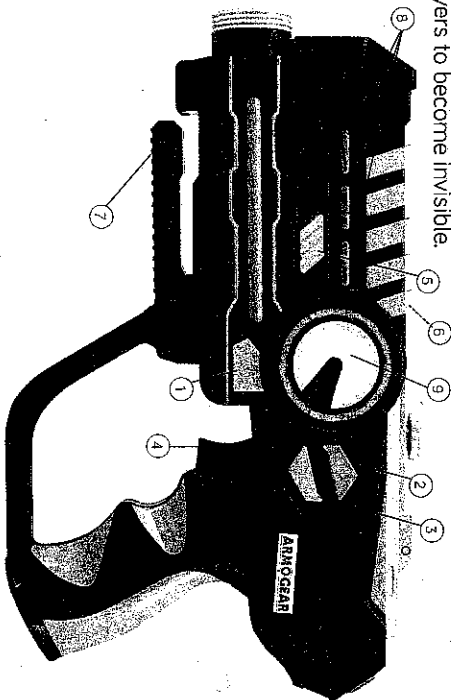

USING THE VEST (illustration)

- Press the ON/OFF button ⑩ to power the laser vest on or off.
- Press the TEAM button ⑪ consecutively to switch between RED, ORANGE, GREEN, and BLUE team ⑫.

Note: Team color does not correspond to the color of your vest.

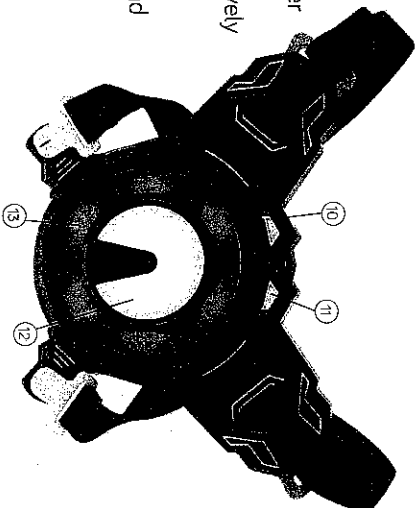

PLAYING LASER BATTLE

Objective:

Wipe the enemy out by shooting on target, taking their lives, and sending them off the playing field - while trying to avoid getting yourself hit! Last team to remain in the game wins!

Instructions:

1. Turn your gun on ① and choose your team color ② and weapon mode ③ using the instructions above. Weapon mode may be switched during the game.

Note: When switching weapon mode during gameplay, make sure to load ⑦ your weapon before shooting.

2. Turn your vest on ⑩ and select your team color ⑪, making sure to coordinate with the color selected on your gun ⑨. Then put it on according to the instructions above.
3. Wait until all players have made their selections and are ready to play.
4. One player counts till 10 while all players scatter. Try to stake out a good shooting spot.
5. Ready, set, go! It's time to wipe the enemy out!
6. Take aim and shoot the opposing team on target to take their lives, while trying to defend yourself from being hit.
7. Make sure to reload ⑦ your weapon as needed.
8. You have 9 lives per game. The LIVES INDICATOR light ⑬ on your vest will display how many lives are remaining.
9. When all 9 lives are taken, you are out of the game and must step off the playing field.
10. The team that stays on the field last wins!

Optional: You may play the game without the vests, by using guns only, as the target. Ensure your RECEIVER switch ⑥ is turned to ON.

The LIVES INDICATOR light ⑧ on your gun will activate and display the number of lives remaining.

Note: Shooting at your own team members will not cause them to get hit. You may not cover/hide your vest or gun, or wrestle other players.

VOLUME CONTROL

To adjust the volume on your Armogear Gun, press and hold the TEAM button ② and for the Armogear Vest, press and hold the TEAM button ⑪

Safety Information

- Young children in play are unaware of potential dangers and hazards, therefore responsible adult supervision is essential.
- Warning: Please do not alter product in any way.
- Colors and contents may vary from illustrations shown.
- Adult supervision is recommended.
- Do not mix old and new batteries.
- Do not mix alkaline, standard carbon-zinc or rechargeable nickel-cadmium batteries.
- Non-rechargeable batteries are not to be recharged.
- Rechargeable batteries are to be removed from the toy before being charged.
- Rechargeable batteries are only to be charged under adult supervision.
- Exhausted batteries are to be removed from the toy.
- Long cord/strap, strangulation hazard.
- This product does not use laser. Uses Infrared technology with 941.6nm wavelength. Beam is not visible.
- Conforms to the toy safety regulations of ASTM F963, CPSIA, EN71-123, EN60825-1, and ROHS.

Warning! Remove all packaging clips, staples, ties and similar attachments before giving this toy to a child. Please retain all information relating to this product for future reference.

Manufactured and
Imported by:

ARMOGEAR

801 Barton Springs Rd.
TX 78704 Austin

support@kidzlane.zendesk.com