

# **VEVOR<sup>®</sup>**

**TOUGH TOOLS, HALF PRICE**

Technical Support and E-Warranty Certificate [www.vevor.com/support](http://www.vevor.com/support)

## **BUTTON MAKER MACHINE INSTRUCTION MANUAL**

We continue to be committed to provide you tools with competitive price. "Save Half", "Half Price" or any other similar expressions used by us only represents an estimate of savings you might benefit from buying certain tools with us compared to the major top brands and does not necessarily mean to cover all categories of tools offered by us. You are kindly reminded to verify carefully when you are placing an order with us if you are actually saving half in comparison with the top major brands.

## SAFETY REMINDER

1. This badge machine is only applied for the intended purpose. Don't apply in other applications which exceed safety considerations.
2. Children cannot operate this product unless accompanied by an adult.
3. Pay attention to safety during operation, and avoid crushing fingers.

## COMPONENTS

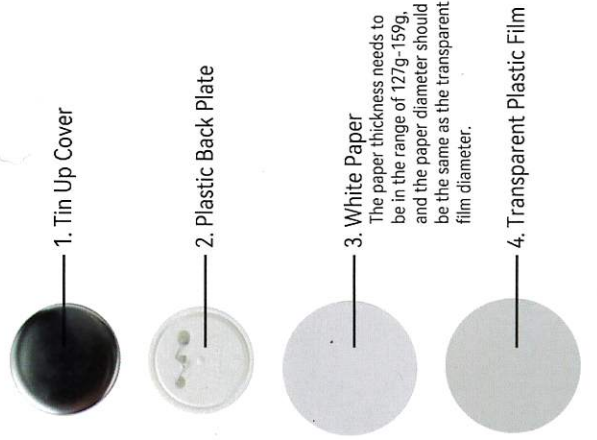
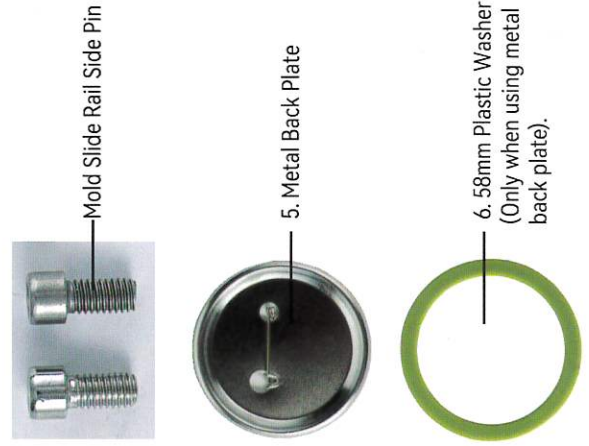
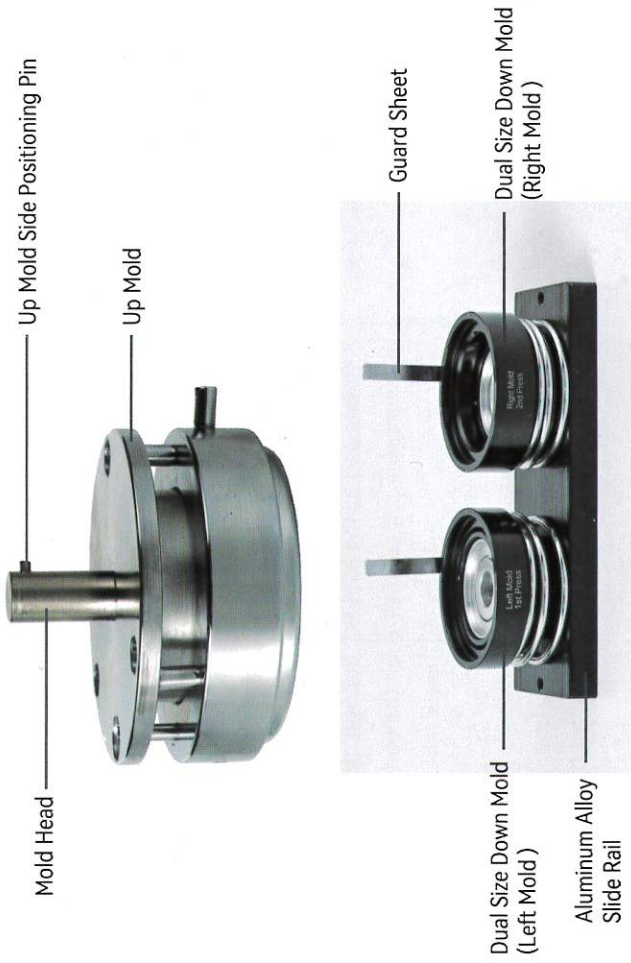
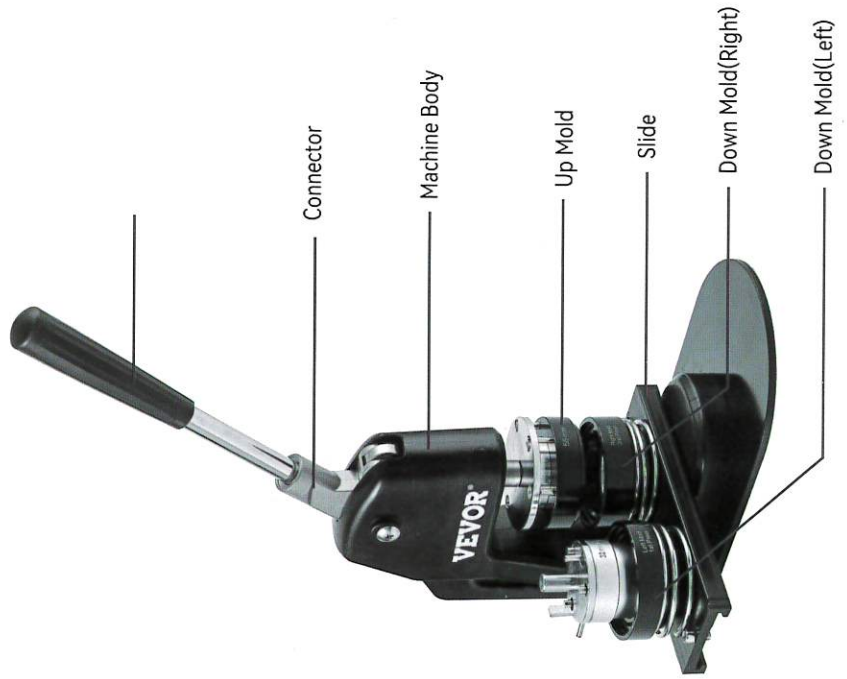







## INSTALLATION STEPS





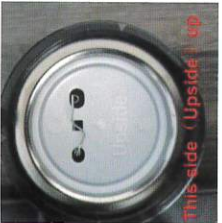

	<p>1. Bolt the fuselage to the base and tighten with a wrench.</p>		<p>2. Rotate and fix the handle to the machine.</p>		<p>3. Align the pins on the upper mold with the slots on the body and push the upper mold upward to complete the assembly of the upper mold.</p>
	<p>4. Align pins and holes in the upper mold to lift it. Align the lower mold with the slide slot and push it to the center.</p>		<p>5. Place the pins in the holes on both sides of the slide rail.</p>		<p>6. Assembly is complete.</p>

## How to Replace Molds

	<p>1. When you want to replace the mold, remove the pins on both sides of the lower mold.</p>		<p>2. Align pins and holes in the upper mold to lift it. Remove the lower mold.</p>		<p>3. Remove the upper mold with force.</p>
	<p>4. Align the pins on the upper mold with the slots on the body and push the upper mold upward to complete the assembly of the upper mold.</p>		<p>5. Align pins and holes in the upper mold to lift it. Align the lower mold with the slide slot and push it to the center.</p>		<p>6. Place the pins in the holes on both sides of the slide rail.</p>
	<p>7. Assembly is complete.</p>				

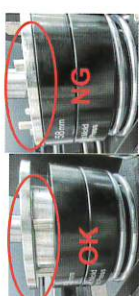
# How to make a badge

	<p>9. Hold the Armrest with one hand and with the other hand hold the Handle, then press down until the bottom.</p>  <p>NOTE: It is OK that the PINS go through the up plate of the Upper Model.</p>	
	<p>8. Push the Right mold under the Upper mold. NOTE: the upper and lower molds must be on the same vertical line.</p>	
	<p>7. Put the Plastic Back Plate in the Right mold.</p>   <p>NOTE: If use the Metal Back Plate (Size: 58mm ) that you need to put the Plastic Washer first.</p>	 <p>10. Take out the badge and the operation complete.</p>

	<p>3. Put White Paper in the Left mold, Note: If you want to make a badge with a pattern, the white paper needs to be replaced with a patterned paper.</p>	 <p>6. Hold the Armrest with one hand and with the other hand hold the Handle, then press down until the bottom.</p>  <p>NOTE: It is OK that the PINS don't go through the up plate of the Up Model.</p>
	<p>2. Put Tin Up Cover in the Left mold.</p>	 <p>5. Push the Left mold under the Upper mold. NOTE: the upper and lower molds must be on the same vertical line.</p>
	<p>1. Prepare required materials.</p>	 <p>4. Put Transparent Plastics Film in the Left mold.</p>

## FAILURE AND TROUBLESHOOTING

You can scan the following QR code to get the operation video.

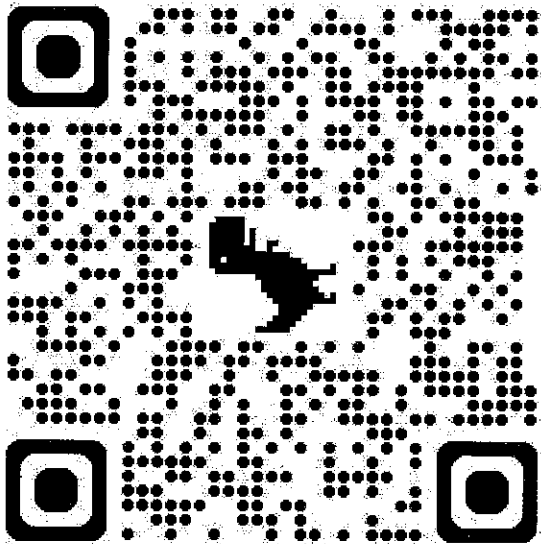

Failure Appearance	Possible Reasons	Troubleshooting
After following step 6, the Tin up cover is not attached to the upper mold.	<ol style="list-style-type: none"> <li>Unsuitable operating method.</li> <li>Too much lubricating oil in the up mold.</li> </ol>	<ol style="list-style-type: none"> <li>When working under step 6 PINS go through the up plate of the Upper Model.</li> <li>The up and down mold must be on the same vertical line when closing.</li> <li>If you find too much lubricant on the upper mold, wipe it off completely with a clean cloth or paper towel.</li> </ol>
Badge incomplete after following step 9	<ol style="list-style-type: none"> <li>Unsuitable operating method</li> </ol>	<ol style="list-style-type: none"> <li>When following step 8, the upper and lower molds must be on the same vertical line.</li> </ol>

	<ol style="list-style-type: none"> <li>Unsuitable paper thickness</li> <li>Up mold screws loosen</li> </ol>	<ol style="list-style-type: none"> <li>Use the stipulated thickness paper.</li> <li>Place the up mold on the machine body, use the complimentary Allen key to fix the screws in the up mold internal hole center.</li> </ol>
	<ol style="list-style-type: none"> <li>The downward press is not in place, not press to the bottom.</li> <li>Paper is thinner</li> <li>( 58mm ) Configured metal back consumables do not place the washer</li> </ol>	<ol style="list-style-type: none"> <li>Need press to the bottom when downward pressing.</li> <li>Change to use a slightly thicker paper.</li> <li>Right side mold place 2mm thickness washer when using the metal back consumables.</li> </ol>
Not tightly press the badge, pressed in but not firm		Use a sharp tool (such as a straight screwdriver) to align to middle merge position clearance which is between up and down mold, and pry open with the object like a hammer (Attention: Just tap it, generally, it will not be too tightened).
Up mold unable to lift up after pressing manufacture, blocked	<ol style="list-style-type: none"> <li>Up and down mold position deviated</li> <li>The paper is incorrectly cut round or blocked by a foreign object.</li> </ol>	

# MODEL AND PARAMETER

Model	BJS-25/58-BK-001	BJS-32/58-BK-001
Manufactured Badge Specification	φ25&58	φ32&58
Color	Black	Black
Paper Requirements	127-157g Copper Plate Paper	127-157g Copper Plate Paper
Accessories With Machine	1.58 Iron Bottom Back Plate * 100 Pieces 58 Plastic Bottom Back Plate * 100 Pieces 2.58 Iron Bottom Cover * 200 Pieces 3.32 Iron Bottom Back Plate * 150 Pieces 32 Plastic Bottom Back Plate * 150 Pieces 4.32 Iron Bottom Cover * 300 Pieces 5.32 Blank Round Paper * 50 Pieces 6.58 Blank Round Paper * 20 Pieces 7.58 Transparent Film * 200 Pieces 8.32 Transparent Film * 300 Pieces 9.58 Round Cutter * 1 Piece 10.32 Round Cutter * 1 Piece 11.Allen Key * 2 Pieces 12.Magic Book * 1 Set 13.58 Washer * 2 Pieces 14.Instruction * 1 Set	1.58 Iron Bottom Back Plate * 100 Pieces 58 Plastic Bottom Back Plate * 100 Pieces 2.58 Iron Bottom Cover * 200 Pieces 3.32 Iron Bottom Back Plate * 150 Pieces 32 Plastic Bottom Back Plate * 150 Pieces 4.32 Iron Bottom Cover * 300 Pieces 5.32 Blank Round Paper * 50 Pieces 6.58 Blank Round Paper * 20 Pieces 7.58 Transparent Film * 200 Pieces 8.32 Transparent Film * 300 Pieces 9.58 Round Cutter * 1 Piece 10.32 Round Cutter * 1 Piece 11.Allen Key * 2 Pieces 12.Magic Book * 1 Set 13.58 Washer * 2 Pieces 14.Instruction * 1 Set

Manufacturer: Shanghaimuxinmuyeyouxiangongsi

Address: Shuangchenglu 803nong11hao1602A-1609shi, baoshanqu, shanghai 200000 CN.

EC REP: E-CrossStu GmbH.

Mainzer Landstr.69, 60329 Frankfurt am Main.

UK REP: YH CONSULTING LIMITED.

C/O YH Consulting Limited Office 147, Centurion House, London Road,

Staines-upon-Thames, Surrey, TW18 4AX

Imported to AUS: SIHAO PTY LTD.

1 ROKEVA STREETEASTWOOD NSW 2122 Australia

Imported to USA: Sanven Technology Ltd.

Suite 250, 9166 Anaheim Place, Rancho Cucamonga, CA 91730

58mm

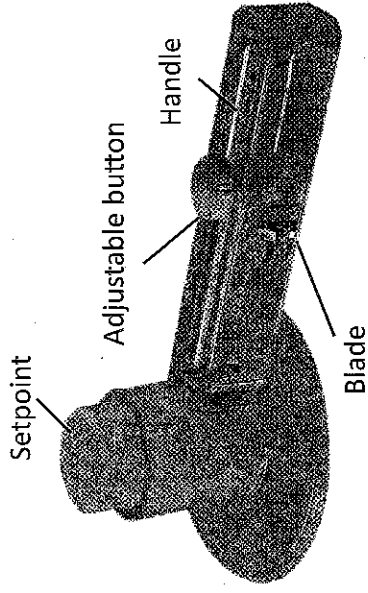

## INSTRUCTIONS

1. Loosen the adjustable button, and move the blade to the edge of setpoint, then tighten the adjustable button.
2. Place the specified picture on a flat surface, and put the setpoint upon the picture, make sure the picture is in the centre.
3. Hold still the setpoint and rotate the handle to cut the picture off.

32mm

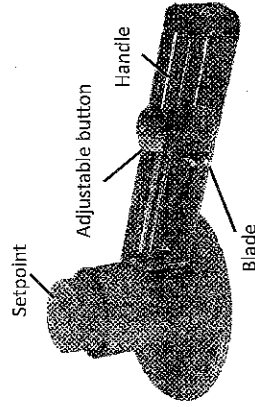

## INSTRUCTIONS

1. Loosen the adjustable button, and move the blade to the edge of setpoint, then tighten the adjustable button.
2. Place the specified picture on a flat surface, and put the setpoint upon the picture, make sure the picture is in the centre.
3. Hold still the setpoint and rotate the handle to cut the picture off.