

HSFTOOLS



**Handheld Thermal Camera
User Manual**



First-time Use

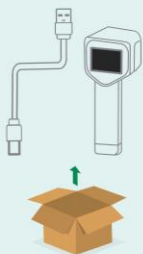

Third-party
5V/2A

Charge for 3h with
supplied cable



Long Time Unused



Charge for ≥ 30 mins with
supplied cable while
device is off



Use supplied cable for data
transfer and screen casting

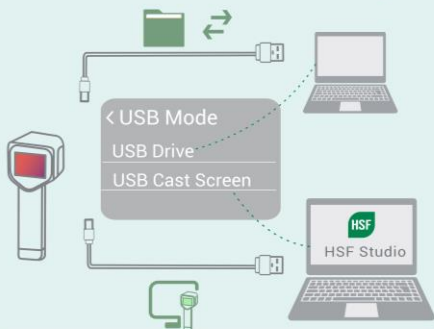

Third-party



CONTENTS

1 Introduction	1
1.1 Introduction of Our Product.....	1
1.2 Main Function	1
2 Appearance	1
2.1 Components	1
3 Preparation	4
3.1 Charge Device.....	4
3.2 Power On/Off	4
3.2.1 Set Auto Power-off Duration	4
3.2.2 Set Auto Sleep.....	4
3.3 Live View	5
4 Start With Scene Mode.....	5
4.1 Select a Scene Mode	5
4.2 (Optional) Set Scene Mode Parameters	7
5 Precise Temperature Measurement.....	8
5.1 Set Temperature Measurement Parameters.....	8
5.1.1 Adjust Distance	8
5.1.2 Adjust Emissivity.....	8
5.1.3 (Optional) Adjust Other Parameters	9
5.2 Set Measurement Tools.....	9
5.3 Set Thermometer Mode (If Applicable)	9
6 Set Alarms.....	10
7 Display Settings	10
7.1 Set Super Resolution	10
7.2 Set Image Mode	11
7.3 Set Color Distribution	11
7.4 Set Palettes.....	11
7.5 Set Level & Span.....	11
7.6 Display OSD Info	12
8 Snapshots and Videos	12
8.1 Capture Snapshots	12
8.2 Record Video	12
8.3 View Snapshots and Videos	13
8.3.1 View Snapshots	13
8.3.2 View Videos.....	13
8.4 Export Snapshots	13
9 Cast Screen.....	13

10 Maintenance	14
10.1 View Device Information	14
10.2 Set Language.....	14
10.3 Save Operation Logs	14
10.4 Format Storage.....	14
10.5 Upgrade	14
10.6 Restore Device	14
11 Frequently Asked Questions (FAQ)	15

1 Introduction

1.1 Introduction of Our Product

The handheld thermal camera is a camera with thermal and optical images. The built-in high-sensitivity IR detector and high-performance sensor detect the temperature change and measure the real-time temperature.

The handheld thermal camera is based on the thermal technology, specially designed for the needs of temperature measuring applications. People can quickly troubleshoot faults on-site.

1.2 Main Function

Scene (If Applicable)

The camera supports multiple scene modes for different detection targets and scenarios. Some scene modes support IntellFault, an intelligent function. It can assist in anomaly detection and give prompts on top of the live view interface.

Temperature measurement

Device detects the real-time temperature, and display it on the screen.



Super Resolution

The device adopts super resolution technology in live streaming, making live image clearer and with more details. Go to **Settings > Super Resolution** to enable the function.



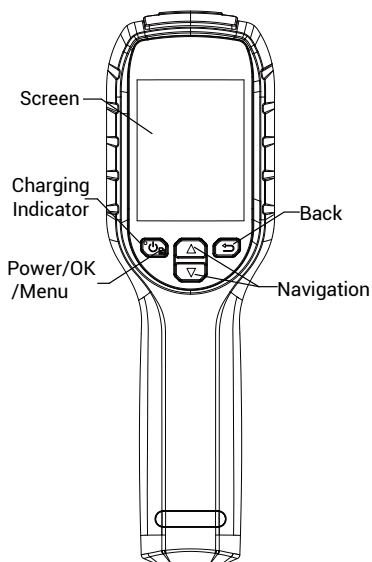

2 Appearance

2.1 Components



Button	Function
	Hold: Power On/Off Press: Display menu or confirm operation
	Exit the menu or return to previous menu.



In menu mode: Press  and  to select parameters.
In live view mode: Press  to switch image modes (only supported by certain models). Press  to switch palettes.

Appearance 1

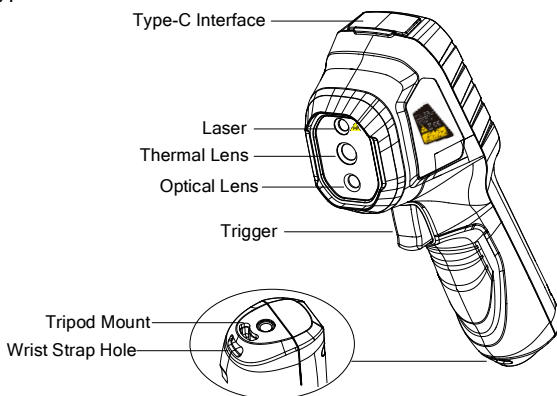

Appearance 2

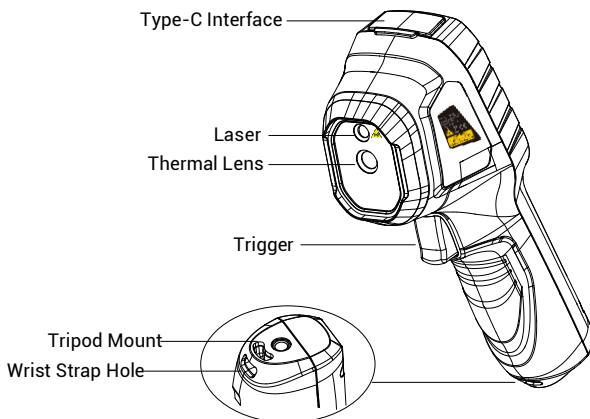

Appearance 3

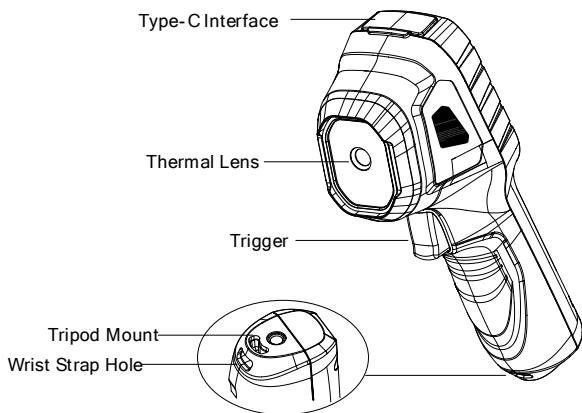

Component	Function
Screen	Views live view.
Charging Indicator	<ul style="list-style-type: none"> • Solid Red: Charging. • Solid Green: Fully charged.
Type-C Interface	Charge the battery or export snapshots.
Laser	Locates the target with laser light (only supported by certain models).
Thermal Lens	Generates thermal images.
Optical Lens	Generates optical images (only supported by certain models).
Trigger	<p>In live view:</p> <ul style="list-style-type: none"> • Press: Capture snapshots. • Hold: <ol style="list-style-type: none"> 1) Locate the target with laser light (for the models with laser light), and release to capture snapshots. 2) Record videos (if the laser is on, turn on the Record switch before recording). <p>In menu mode, press the trigger to go back to live view.</p>
Wrist Strap Hole	Mounts the wrist strap.
Tripod Mount	Connect to UNC 1/4"-20 tripod.

 **NOTE**

- The appearance and button functions vary according to different models.
- The optical lens is only supported by certain models. Please refer to the actual device or datasheet.
- The warning sign is beside the laser and on the left side of the device.



Warning:

The laser radiation emitted from the device can cause eye injuries, burning of skin or inflammable substances. Prevent eyes from direct laser. Before enabling the Light Supplement function, make sure no human or inflammable substances are in front of the laser lens. The wave length is 650 nm, and the power is less than 1 mW. The divergence angle is $0.05^\circ \pm 0.01^\circ$. The laser meets the IEC 60825-1:2014 standard. Protective eyewear can protect persons against laser sources. The operating wavelength of the eyewear should be longer than the laser peak wavelength, and the optical density should be higher than OD5+.

3 Preparation

3.1 Charge Device

1. Lift the type-C interface cover.
2. Connect the device to power supply using the type-C cable to charge the device.

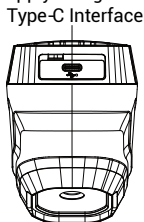

 NOTE

- The power delivered by the charger must be between min 6.7 Watts required by the radio equipment, and max 10 Watts in order to achieve the maximum charging speed.
- The device is equipped with the built-in battery. For the first charge, charge the device for more than 3 hours when the device is turned on. **Do not use the USB-C to USB-C cable from other manufacturers.**

3.2 Power On/Off

Power On

Hold  for over six seconds to turn on the device. You can observe the target when the interface of the device is stable.

Power Off

When the device is on, hold  for six seconds to power off the device.

3.2.1 Set Auto Power-off Duration

In the live view interface, press  and go to **More Settings > Auto Power-off** to set the automatic shutdown time for device as required.

3.2.2 Set Auto Sleep

In live view interface, press  and go to **More Settings > Auto Sleep** to set the waiting time before auto sleep. When there is no button pressing on the device for more than the set waiting time, the device enters sleep mode automatically. Press a button to wake the device up.

3.3 Live View

The live view interface of different models may vary. Take the actual product for reference.

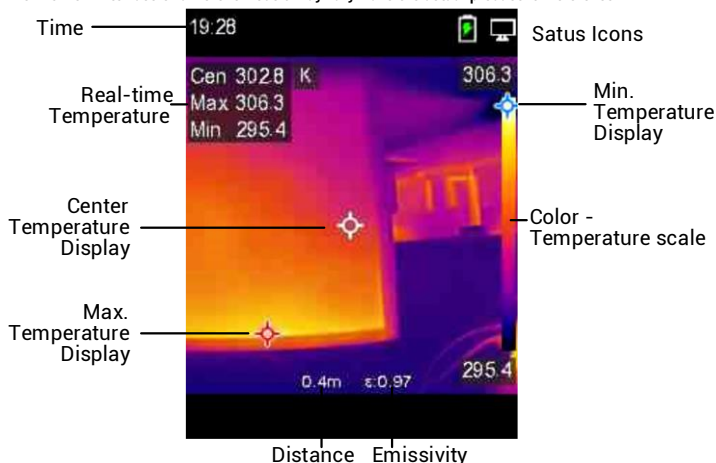

NOTE

- Because this manual is updated on a regular basis, the live view might be slightly different from the version of your particular camera model. Please refer to the actual camera.
- If the temperature value is preceded by a "~", it indicates that the temperature measurement function has not reached a precise state. This symbol usually appears during the device startup phase and disappears once the temperature measurement function is fully operational.



4 Start With Scene Mode

To conduct fast anomaly detection, several preset templates are included in Scene mode for various detection scenarios. Users can choose an appropriate scene or customize a scene as per targets, and set high temperature alarm as needed. Scene mode is ONLY supported by some models in the series. Please refer to your actual device and its software version.

1. Select an appropriate scene mode. See 4.1 *Select a Scene Mode* for details.
2. (Optional) Fine-tune scene mode parameters as needed. See 4.2 *(Optional) Set Scene Mode Parameters* for details.
3. (Optional) Set alarms as needed. See 6 *Set Alarms* for details.
4. Observe detection results in live view interface.

4.1 Select a Scene Mode

Choose a scene mode according to the faults or anomalies you want to locate in a specific detection scene. It is ONLY supported by some models in the series.

1. In the live view interface, press  and go to **Scene > Scene**.
2. Press  to select an appropriate scene mode.

NOTE

Default value of parameters work for most cases. If users want to fine-tune the related parameters as needed, see 4.2 (Optional) Set Scene Mode Parameters.

Water Leak

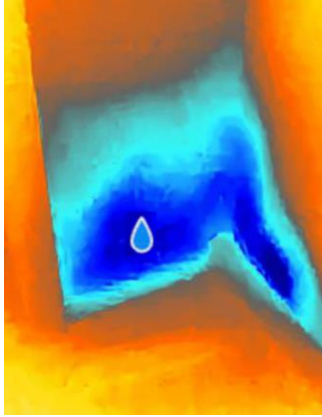

To inspect the water leak of building ceilings, walls and floors indoors.

IntellFault technology can assist in fast recognition for anomalies during water leak detection. When **IntellFault** is enabled and water leak anomalies are detected, **Suspect** will be displayed on top of live view.

NOTE

- False positives and false negatives emerge when temperature difference of the areas with leak anomalies is too subtle to be recognized, or the thermal imaging features are not obvious.
- It is recommended to give a second diagnosis based on IntellFault function. The algorithm of IntellFault function is being updated.

Insulation



To detect indoor insulation deficiency of building walls, ceilings, common users can apply this scene.

IntellFault technology can assist in fast recognition for anomalies during insulation detection. When **IntellFault** is enabled and insulation anomalies are detected, **Suspect** will be displayed on top of live view.

 **NOTE**

- False positives and false negatives emerge when temperature difference of the areas with leak anomalies is too subtle to be recognized, or the thermal imaging features are not obvious.
- It is recommended to give a second diagnosis based on IntellFault function. The algorithm of IntellFault function is being updated.

Floor Heating

To detect and observe the faults of floor heating system.

Electrical Faults

To detect and observe the faults of wires, circuits, and electrical components, terminators, etc.

Solar Panel



To detect and observe the faults of solar panels.

Custom

Users can customize a mode to save desired temperature measurement parameters for future use. See 4.2 (Optional) Set Scene Mode Parameters.

4.2 (Optional) Set Scene Mode Parameters

To obtain a more precise detection results, users can fine-tune the related parameters.

1. In Scene mode, choose an appropriate scene and then press  to set parameters.
2. Adjust the parameters according to the table.
3. Press  to save and exit.

 **NOTE**

Parameters vary from the different scenes.

Parameters	Description
Emissivity	Set the emissivity according to your target.
Palettes	Thermal images are created by temperature difference. Users can switch different palettes as preferred.
Level & Span	Temperature scale on right side supports browsing color-temperature relationship in the image. Set the level & span parameters to get better image contrast. See 7.5 Set Level & Span.
Temperature Range	Select the temperature measurement range. The device can detect the temperature and switch temperature measurement range automatically in Auto Switch mode.
Alarm	When the temperature of targets triggers the set alarm rule, users can be notified in the set ways. See 6 Set Alarms.
Color Distribution	Linear and Histogram modes are selectable for different application scenes, so as to display more details.

- **Linear:** Detect small high temperature targets in low temperature background to enhance and display more details of high temperature targets, such as cable connectors.
- **Histogram:** Detect small low temperature targets in high temperature areas to enhance temperature difference and remain details of low temperature objects, such as cracks.

5 Precise Temperature Measurement

To get more precise and real-time temperature of the target, user can set spot tools and alarm as needed.



1. For models with scene modes, select a proper scene to speed up the measurement settings. See 4 *Start With Scene Mode*.
2. Verify temperature values in the top-left corner of live view. If they are not precise enough, fine-tune temperature measurement parameters. See 5.1.3 *(Optional) Adjust Other Parameters*.
3. (Optional) Users set spot tools to get the real-time temperature of the highest/lowest/center temperature spot. See 5.2 *Set Measurement Tools*.
4. (Optional) Set the alarm. The target whose temperature value is above or below the set threshold value can trigger the alarm. See 6 *Set Alarms*.

5.1 Set Temperature Measurement Parameters

You should set temperature measurement parameters before measuring temperature.

5.1.1 Adjust Distance



The distance between the camera and the observation target affects the accuracy of the temperature results. Before temperature measurement, users should set the distance first.

1. In the live view interface, press  to show the menu.
2. Press  to select Distance, and then set parameters.
3. Press  to save and exit.

5.1.2 Adjust Emissivity



Emissivity directly affects the measurement accuracy and it is necessary to be re-adjusted according to the characteristics of the target material.

For models with scene mode:

1. In Scene mode, choose an appropriate scene and then press  to set parameters.
2. Adjust the parameters.
3. Press  to save and exit.

For models without scene mode:

1. In the live view interface, press  to show the menu.

2. Press  to select **Emissivity**, and then set parameters.
3. Press  to save and exit.





5.1.3 (Optional) Adjust Other Parameters

To improve the accuracy of temperature measurement, fine-tune temperature measurement parameters.

- **Temperature Range:** Go to **Settings > Temperature Range**, and select the temperature measurement range. The device can detect the temperature and switch temperature measurement range automatically in Auto Switch mode.
- **Unit:** Go to Display **Settings > Unit**, and press  to set the temperature unit.

5.2 Set Measurement Tools



Device measures the temperature of the whole scene and can be managed to display the center, hot, and cold spot in the scene.

1. In the live view interface, press  to show the menu.
2. Press  to select **Display Settings**.
3. Select the desired spots to show their temperatures, and press  to enable them.
Hot: Display the hot spot in the scene and show the max. temperature.
Cold: Display the cold spot in the scene and show the min. temperature.
Center: Display the center spot in the scene and show the center temperature.
4. Press  to save and exit. The device shows the real-time temperature on the upper left side of live view interface.

 **NOTE** If there is serious inaccuracy in temperature results, turn off **IntellAccu** button by **Settings > IntellAccu**. IntellAccu function is **ONLY** supported by some models.

5.3 Set Thermometer Mode (If Applicable)

The **Thermometer Mode** utilizes a laser pointer to help users quickly locate temperature measurement points. When enabled, the laser pointer indicates the target in the scene, allowing users to visualize its temperature in real time. Devices without laser do not support this mode.

1. In the live view, press  to show the menu, then press  to enable Thermometer Mode. Press  to save and exit.
2. In the live view, hold the trigger. The device will emit laser to aim at the target. A red laser indicator dot will appear at the center of the screen, accompanied by the temperature value of the target (consistent with the center point temperature).
3. Release the trigger.
 - If video recording is enabled (see 8.2 *Record Video*), the device will continue recording, and the laser dot will disappear.
 - If video recording is not enabled, the device will automatically capture an image of the current scene and save the temperature data.



 **NOTE**

- In Thermometer Mode, the laser pointer cannot be turned off. To turn off the laser, disable this mode first.
- In Thermometer Mode, the maximum, minimum, and center temperature values are not displayed in the top-left corner of the observation interface.





6 Set Alarms

Set the alarm rules and the device will alarm when the temperature triggers the rule.



For models with scene mode:

1. In Scene mode, choose an appropriate scene and then press  to set parameters.
2. Press  and turn on **Alarm**.

 **NOTE** ONLY some scenes support Alarm. Please refer to your actual device.

3. Select **Measurement** to set the alarm rule. Select **Alarm Threshold** to set the threshold temperature. When the target's temperature is higher or lower than the threshold value, the device will output alarm.
4. Press  to save and exit.
5. Press  and press  to enable the **Alarm Linkage** function.
Alarm Mode Palettes: When the target's temperature is higher than the set value, the target will become red; when the target's temperature is lower than the set value, the target will become blue (only supported by certain models).
6. Press  to save and exit.

For models without scene mode:

1. In the live view interface, press  to show the menu.
2. Press  and select **Alarm** and turn it on.
3. Press  to enable the **Alarm Linkage** function.
Alarm Mode Palettes: When the target's temperature is higher than the set value, the target will become red; when the target's temperature is lower than the set value, the target will become blue (only supported by certain models).

 **NOTE** The flash light will turn off automatically after enabling flashing alarm.

4. Select **Measurement** to set the alarm rule. Select **Alarm Threshold** to set the threshold temperature. When the target's temperature is higher or lower than the threshold value, the device will output alarm and other alarm linkage.
5. Press  to save and exit.

7 Display Settings

7.1 Set Super Resolution

The device supports **Super Resolution** on live view (for some models) and on snapshots. Turn on **Super Resolution** to enhance the object outlines for better image display. The actual effect is subject to the actual product.

Go to **Settings > Super Resolution**, and press  to turn it on/off.

- On live view: For some models, the object outlines can be enhanced in live view when super resolution is on.
- On captured images: The object outlines in the image are enhanced after super resolution is on.

7.2 Set Image Mode

You can set image modes of the device. **Image Mode** is only supported by certain models. Please refer to the actual device or the datasheet.



1. Select an image mode by the following ways:
 - Go to **Settings > Image Settings > Image Mode**, and select a preferred image mode.
 - Press  in live view to switch image modes.

Image Mode	Description
Thermal	Display the thermal image only.
Fusion	Fuse the optical image with the thermal image. The fused image with clear edge is displayed in this mode.
Visual	Visual object image only. This function is only supported by the models with visual lens.

2. Press  to save and exit.



 **NOTE** Your camera will periodically perform a self-calibration to optimize image quality and measurement accuracy. In this process the image will pause briefly and you will hear a "click" as a shutter moves in front of the detector. The self-calibration will be more frequent during the startup or in very cold or hot environments. This is a normal part of operation to ensure optimum performance for your camera.

7.3 Set Color Distribution

Color distribution allows you to adjust image effects. You can select histogram or linear pattern. Histogram is suitable for scenarios with large temperature difference, and linear pattern is suitable for scenarios with small temperature difference. You can go to **Settings > Image Settings > Color Distribution** to select histogram or linear pattern.







7.4 Set Palettes

The palettes allow you to select the desired colors. You can switch palettes by the following ways:

- Go to **Settings > Palettes** to select a preferred palette, and press  to save and exit.
- Press  in live view to switch palettes.

7.5 Set Level & Span

Set a display temperature range and palette only works for targets within the temperature range. You can get better image contrast by adjusting the level & span parameters.

1. In the live view interface, press  to show the menu.
2. Press , and select Level & Span.
3. Select Setting Mode, and press  to switch auto and manual adjustment.
 - In **Auto** mode, the device adjusts display temperature range automatically.
 - In **Manual** mode, select **Parameters** to enter the setting interface. Press  to lock or unlock the max. temperature and min. temperature, and press  to adjust unlocked value. Or, unlock the max. temperature and min. temperature, and press  to increase or decrease the individual values while remaining the same temperature range.

4. Press  to save and exit.

7.6 Display OSD Info

Go to **Settings > Display Settings** to enable the on-screen display information.

Parameters

Temperature measurement parameters, e.g. emissivity.

Unit

Set the temperature unit displayed on the live view interface.

Time and Date

Set the time and date displayed on the live view interface.

8 Snapshots and Videos

8.1 Capture Snapshots

You can capture snapshots in live view, and a thumbnail of the snapshot is displayed in live view. The snapshot will be automatically saved in the albums.

Press and release the trigger in live view to capture snapshots.

<input checked="" type="checkbox"/> NOTE	<ul style="list-style-type: none">● For models with laser, go to More Settings > Laser to turn on/off laser light.● Capturing snapshots is unavailable when the device is connected to PC.
------------------------------------------	-----------------------------------------------------------------------------------------------------------------------------------------------------------------------------------------------------------------------------



You can also set the following parameters in **Settings > Capture Mode** before capturing snapshots.

Parameters	Description
Capture Mode	<ul style="list-style-type: none">● Capture One Image: Press the trigger once to capture one image.● Scheduled Capture: Set Interval (the time interval of each snapshot to be taken) and Number (the number of snapshots to be taken in a roll, ranging from 1 to 10,000) for scheduled capture. Press the trigger in live view, and the device captures the set number of images according to the set interval. Press the trigger again to stop capturing.
File Naming	The files can be named after Time Stamp or Numbering (filename header + sequence number).
Save Visual Image	If a visual image is needed to be saved separately, you can enable Save Visual Image (only supported by the models with visual lens).

<input checked="" type="checkbox"/> NOTE	For Scheduled Capture, a counter displays in live view showing the completed amounts of capturing.
------------------------------------------	----------------------------------------------------------------------------------------------------

8.2 Record Video









<input checked="" type="checkbox"/> NOTE	Video recording and the laser share the same trigger button: <ul style="list-style-type: none">● For devices without laser, follow step 2 and 3 for recording.● For devices with laser, follow step 1 to 3 for recording.
------------------------------------------	--------------------------------------------------------------------------------------------------------------------------------------------------------------------------------------------------------------------------------------------------

1. Optional: In the live view interface, press  and go to **Settings > Capture Mode**. Press  and enable **Record**. Press  to save and back to the live view.









2. Hold the trigger in live view. When the recording icon and time display in the interface, recording begins, and you can release the trigger.
3. Press the trigger completes the recording. The device will display a pop-up notification saying "Recording Succeeded". The recording video will be saved.

8.3 View Snapshots and Videos

8.3.1 View Snapshots

1. In the live view interface, press  to show the menu.
2. Press  to select Albums, and press  to enter the album.
3. Press  to select the picture, and press  to view it.
4. Optional: Press  to delete picture in picture view interface. Press  to switch the picture.
5. Press  to exit.

8.3.2 View Videos

1. In the live view interface, press  to show the menu.
2. Press  to select Albums, and press  to enter the album.
3. Press  to select the video, and press  to view it.
4. Optional: Press  to delete video in view interface. Press  to switch the picture.
5. Press  to exit.

8.4 Export Snapshots

Purpose:

Connect the device to your PC with supplied cable, and then you can export the captured snapshots.

Steps:

1. Lift the Type-C interface cover.
2. Connect the camera to your PC with supplied cable, and open the detected disk.
3. Copy and paste the snapshots to PC and view the files.
4. Disconnect the device from your PC.

NOTE

- For the first connection, the driver will be installed automatically.
- DO NOT disconnect the supplied cable from PC during drive installation, or it may cause damage to the device.

9 Cast Screen

The device supports casting screen to PC by UVC protocol-based client software or player. You can connect the device to your PC via the supplied cable, and cast the real-time live view of the device to your PC.

1. Download UVC protocol-based client software from our website:
https://www.hsftools.com/Downloads/HSFTools_Studio_Windows_Software
2. Connect the device to your PC via the supplied cable, and select USB Cast Screen in the prompt on the device as the USB mode. Exporting files via USB connection is not allowed when you are casting the screen.
3. Open the software or player on your PC.

10 Maintenance

10.1 View Device Information

In the live view interface, press  and go to **More Settings > About** to view the device information.



10.2 Set Language

In the live view interface, press  and go to **More Settings > Language** to set the menu language.

10.3 Save Operation Logs

The device can collect its operation logs and save in the storage only for troubleshooting. You can turn on/off this function in **More Settings > Save Logs**. You can connect the camera to PC using the supplied cable, and select **USB Drive** as the USB mode on camera to export the operation logs in the root directory of the camera, if necessary.

10.4 Format Storage

1. In the live view interface, press  and go to **More Settings > Format Storage**.
2. Press  and select OK to start formatting storage.

 **NOTE** Format storage before first use.

10.5 Upgrade

Before You Start:

Download the upgrade file from the official website (www.hsftools.com) first.

Steps:

1. Connect the device to your PC with supplied cable, and open the detected disk.
2. Copy the upgrade file and replace it to the root directory of the device.
3. Disconnect the device from your PC.
4. Reboot the device and then it will upgrade automatically. The upgrading process will be displayed in the main interface.

 **NOTE** After the upgrade, the device automatically reboots. You can view the current version in **More Settings > About**.

10.6 Restore Device

In the live view interface, press  and go to **More Settings > Restore Device** to initialize the device and restore default settings.

11 Frequently Asked Questions (FAQ)

Q: The charge indicator flashes red.

A: Examine the items below.

1. Examine whether the device is charged with the standard power adapter.
2. Make sure the environment temperature is above 0°C (32°F).

R: Capturing fails.

A: Examine the items below:

1. Whether the device is connected to your PC and the capture function is unavailable.
2. Whether the storage space is full.
3. Whether the device is low-battery.

Q: The PC cannot identify the camera.

A: Examine whether the device is connected to your PC with standard cable.

Q: The camera cannot be operated or no responding.

A: Hold  to reboot the camera.

Legal Information

Read all information and instructions in this document carefully before using the device and keep it for further reference.

For more device information and instructions, please visit the manufacturer website. You can also refer to other documents (if any) accompanying the device or scan the QR code (if any) on the packaging to get more information.

About this Manual

The Manual includes instructions for using and managing the Product. Pictures, charts, images and all other information hereinafter are for description and explanation only. The information contained in the Manual is subject to change, without notice, due to firmware updates or other reasons. Please find the latest version of this Manual at the company website

Please use this Manual with the guidance and assistance of professionals trained in supporting the Product.

Trademarks

Trademarks and logos mentioned are the properties of their respective owners.

LEGAL DISCLAIMER

TO THE MAXIMUM EXTENT PERMITTED BY APPLICABLE LAW, THIS MANUAL AND THE PRODUCT DESCRIBED, WITH ITS HARDWARE, SOFTWARE AND FIRMWARE, ARE PROVIDED "AS IS" AND "WITH ALL FAULTS AND ERRORS". OUR COMPANY MAKES NO WARRANTIES, EXPRESS OR IMPLIED, INCLUDING WITHOUT LIMITATION, MERCHANTABILITY, SATISFACTORY QUALITY, OR FITNESS FOR A PARTICULAR PURPOSE. THE USE OF THE PRODUCT BY YOU IS AT YOUR OWN RISK. IN NO EVENT WILL OUR COMPANY BE LIABLE TO YOU FOR ANY SPECIAL, CONSEQUENTIAL, INCIDENTAL, OR INDIRECT DAMAGES, INCLUDING, AMONG OTHERS, DAMAGES FOR LOSS OF BUSINESS PROFITS, BUSINESS INTERRUPTION, OR LOSS OF DATA, CORRUPTION OF SYSTEMS, OR LOSS OF DOCUMENTATION, WHETHER BASED ON BREACH OF CONTRACT, TORT (INCLUDING NEGLIGENCE), PRODUCT LIABILITY, OR OTHERWISE, IN CONNECTION WITH THE USE OF THE PRODUCT, EVEN IF OUR COMPANY HAS BEEN ADVISED OF THE POSSIBILITY OF SUCH DAMAGES OR LOSS. YOU ACKNOWLEDGE THAT THE NATURE OF THE INTERNET PROVIDES FOR INHERENT SECURITY RISKS, AND OUR COMPANY SHALL NOT TAKE ANY RESPONSIBILITIES FOR ABNORMAL OPERATION, PRIVACY LEAKAGE OR OTHER DAMAGES RESULTING FROM CYBER-ATTACK, HACKER ATTACK, VIRUS INFECTION, OR OTHER INTERNET SECURITY RISKS; HOWEVER, OUR COMPANY WILL PROVIDE TIMELY TECHNICAL SUPPORT IF REQUIRED.

YOU AGREE TO USE THIS PRODUCT IN COMPLIANCE WITH ALL APPLICABLE LAWS, AND YOU ARE SOLELY RESPONSIBLE FOR ENSURING THAT YOUR USE CONFORMS TO THE APPLICABLE LAW. ESPECIALLY, YOU ARE RESPONSIBLE, FOR USING THIS PRODUCT IN A MANNER THAT DOES NOT INFRINGE ON THE RIGHTS OF THIRD PARTIES, INCLUDING WITHOUT LIMITATION, RIGHTS OF PUBLICITY, INTELLECTUAL PROPERTY RIGHTS, OR DATA PROTECTION AND OTHER PRIVACY RIGHTS. YOU SHALL NOT USE THIS PRODUCT FOR ANY PROHIBITED END-USES, INCLUDING THE DEVELOPMENT OR PRODUCTION OF WEAPONS OF MASS DESTRUCTION, THE DEVELOPMENT OR PRODUCTION OF CHEMICAL OR BIOLOGICAL WEAPONS, ANY ACTIVITIES IN THE CONTEXT RELATED TO ANY NUCLEAR EXPLOSIVE OR UNSAFE NUCLEAR FUEL-CYCLE, OR IN SUPPORT OF HUMAN RIGHTS ABUSES. IN THE EVENT OF ANY CONFLICTS BETWEEN THIS MANUAL AND THE APPLICABLE LAW, THE LATER PREVAILS.

REGULATORY INFORMATION

These clauses apply only to the products bearing the corresponding mark or information.

FCC Compliance Statement

Note: This product has been tested and found to comply with the limits for a Class B digital device, pursuant to part 15 of the FCC Rules. These limits are designed to provide reasonable protection against harmful interference in a residential installation. This product generates, uses, and can radiate radio frequency energy and, if not installed and used in accordance with the instructions, may cause harmful interference to radio communications. However, there is no guarantee that interference will not occur in a particular installation. If this product does cause harmful interference to radio or television reception, which can be determined by turning the equipment off and on, the user is encouraged to try to correct the interference by one or more of the following measures:

- Reorient or relocate the receiving antenna.
- Increase the separation between the equipment and receiver.
- Connect the equipment into an outlet on a circuit different from that to which the receiver is connected.
- Consult the dealer or an experienced radio/TV technician for help.



Please take attention that changes or modification not expressly approved by the party responsible for compliance could void the user's authority to operate the equipment.

This device complies with part 15 of the FCC Rules. Operation is subject to the following two conditions:

- (1) this device may not cause harmful interference, and
- (2) this device must accept any interference received, including interference that may cause undesired operation.

Safety Instruction

The symbols that may be found in this document are defined as follows.

Symbol	Description
 Danger	Indicates a hazardous situation which, if not avoided, will or could result in death or serious injury.
 Caution	Indicates a potentially hazardous situation which, if not avoided, could result in equipment damage, data loss, performance degradation, or unexpected results.
 NOTE	Provides additional information to emphasize or supplement important points of the main text.

These instructions are intended to ensure that user can use the product correctly to avoid danger or property loss.

Laws and Regulations

Use of the product must be in strict compliance with the local electrical safety regulations.

Transportation

- Keep the device in original or similar packaging while transporting it.
- Keep all wrappers after unpacking them for future use. In case of any failure occurred, you need to return the device to the factory with the original wrapper. Transportation without the original wrapper may result in damage on the device and the company shall not take any responsibilities.
- Do not drop the product or subject it to physical shock. Keep the device away from

magnetic interference.

Power Supply

- Input voltage should meet the Limited Power Source. Please refer to technical specifications or device label for detailed information.
- Make sure the plug is properly connected to the power socket.
- DO NOT connect multiple devices to one power adapter, to avoid over-heating or fire hazards caused by overload.
- Use the power adapter provided by a qualified manufacturer. Refer to the product specification for detailed power requirements.

Battery

- The built-in battery cannot be dismantled. Please contact the manufacture for repair if necessary.
- CAUTION: Risk of explosion if the battery is replaced by an incorrect type.
- Improper replacement of the battery with an incorrect type may defeat a safeguard (for example, in the case of some lithium battery types).
- Do not dispose of the battery into fire or a hot oven, or mechanically crush or cut the battery, which may result in an explosion.
- Do not leave the battery in an extremely high temperature surrounding environment, which may result in an explosion or the leakage of flammable liquid or gas.
- Do not subject the battery to extremely low air pressure, which may result in an explosion or the leakage of flammable liquid or gas.
- Dispose of used batteries according to the instructions.
- For long-term storage of the battery, make sure it is fully charged every 3 months to ensure the battery quality. Otherwise, damage may occur.
- Make sure the plug is properly connected to the power socket.
- When the device is powered off and the battery is full, the time settings can be kept for 60 days.
- The standard adapter power supply is 5 V.
- The battery is certified by UL2054.

Maintenance

- If the product does not work properly, please contact your dealer or the nearest service center. We shall not assume any responsibility for problems caused by unauthorized repair or maintenance.
- Wipe the device gently with a clean cloth and a small quantity of ethanol, if necessary.
- If the equipment is used in a manner not specified by the manufacturer, the protection provided by the device may be impaired.
- Your camera will periodically perform a self-calibration to optimize image quality and measurement accuracy. In this process the image will pause briefly and you will hear a "click" as a shutter moves in front of the detector. The self-calibration will be more frequent during the startup or in very cold or hot environments. This is a normal part of operation to ensure optimum performance for your camera.

Using Environment

- Make sure the running environment meets the requirement of the device. The operating temperature shall be -10 °C to 50 °C (14 °F to 122 °F), humidity shall be 95% or less.
- Place the device in a dry and well-ventilated environment.
- DO NOT expose the device to high electromagnetic radiation or dusty environments.
- DO NOT aim the lens at the sun or any other bright light.
- When any laser equipment is in use, make sure that the device lens is not exposed to the laser beam, or it may burn out.
- The device is suitable for indoor and outdoor uses, but do not expose it in wet conditions.
- The level of protection is IP 54.
- The pollution degree is 2.

Emergency

If smoke, odor, or noise arises from the device, immediately turn off the power, unplug the power cable, and contact the service center.

Laser Light Supplement Warning



Warning: The laser radiation emitted from the device can cause eye injuries, burning of skin or inflammable substances. Prevent eyes from direct laser. Before enabling the Light Supplement function, make sure no human or inflammable substances are in front of the laser lens. The wave length is 650 nm, and the power is less than 1 mW. The divergence angle is $0.05^\circ \pm 0.01^\circ$.

The laser meets the IEC 60825-1:2014 standard. Protective eyewear can protect persons against laser sources. The operating wavelength of the eyewear should be longer than the laser peak wavelength, and the optical density should be higher than OD5+.

Laser maintenance: It is not necessary to maintain the laser regularly. If the laser does not work, the laser assembly needs to be replaced in the factory under warranty. Keep the device power off when replacing laser assembly. Caution-Use of controls or adjustments or performance of procedures other than those specified herein may result in hazardous radiation exposure.

Manufacture Address

No.5, VSIP II, Street 7, Vietnam-Singapore Industrial Park II Binh Duong, Hoa Phu ward, TDM Town, Binh Duong Province
CARVE VIET NAM TECHNOLOGY COMPANY LIMITED

COMPLIANCE NOTICE: The thermal series products might be subject to export controls in various countries or regions, including without limitation, the United States, European Union, United Kingdom and/or other member countries of the Wassenaar Arrangement. Please consult your professional legal or compliance expert or local government authorities for any necessary export license requirements if you intend to transfer, export, re-export the thermal series products between different countries.

HSFTOOLS