

SINGER
281-30

SINGER*

Service Manual

(TEMPORARY)

281-30 Machines

~~281-5, 281-6, 281-20, 281-22,~~

~~281-23 and 281-24~~

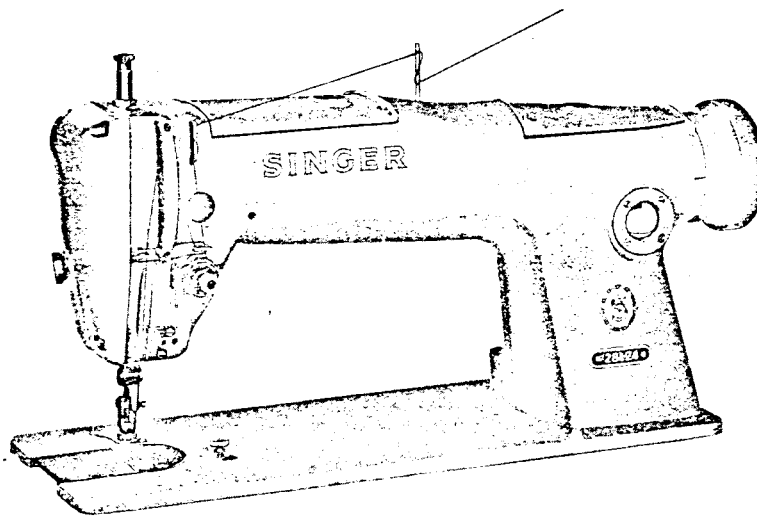

Regulation View - Machine 281-24

THE SINGER COMPANY

Copyright © 1964 by The Singer Company
Copyright Under International Copyright Union
All Rights Reserved under Inter-American Copyright Union

DESCRIPTION OF MACHINES

Machines of Class 281- are high speed, single needle, lockstitch machines designed for sewing materials ranging from light weight to heavy weight.

Among the varieties covered in this manual are puller-feed and needle-feed machines, top-gripper machines and machines that perform simultaneous trimming and stitching.

All of these machines produce outstanding straight line stitching in a wide range of wash-and-wear, synthetic and natural fabrics.

General Features

Federal stitch type 301.

Balanced, air cooled, rotating hook. Horizontal axis.

Lint wiper keeps lint and abrasive matter from accumulating on hook.

Drop feed consists of pendant link feed with feed leveling hinge pin.

Pendant link feed mechanism maintains longer feeding cycle.

Three plain superfinished bearings support the arm shaft.

Fully automatic lubricating system with oil flow window in direct view of operator.

Knee lifter mechanism integral with machine base and oil reservoir.

Independent light fixture mount.

Improved needle thread guard and other thread handling parts. Disc tension.

Machine pulley 147139 for 3/8 inch V-belt.

Space at right of needle, 11 inches.

Machine Varieties

Machine 281-5, Vertical Trimmer

Medium weight and heavy weight fabrics.

Needle bar stroke, 1-13/64 inches

Presser bar lift, 5/16 inch.

Knife bar stroke, 5/16 inch.

Maximum stitch length, with regular fittings, 5-1/2 stitches per inch.

Needle, Catalog 1515 (16x95).

Bed-raising plate sets flush with top of throat plate.

Regularly fitted to trim 1/8 inch from line of stitching. Extra cutting bar and presser foot supplied for 3/16 inch.

When specified on order, machines can be fitted for 1/16, 3/32, 5/32, 3/16 or 1/4 inch trim margin.

Extra cutting bar and presser foot furnished in each instance will be next size larger than that ordered.

When 1/4 inch (widest trim margin) is requested, two sets of this size will be supplied with machine.

Speed, 5000 stitches per minute.

Machine 281-6, Top Gripper

Collar and cuff operations on light weight to medium weight fabrics.

Top driven gripper feed. Top feed intermittently driven by linkage actuated through countershaft.

Countershaft driven by eccentric on arm shaft. Eccentric adjustable to obtain optimum relationship between top and bottom feed.

Top feed designed to grip fabric at same moment that bottom feed rises to make contact and to travel with bottom feed during its entire front to rear feeding motion.

Top feed then returns (in raised position above material) to beginning of next grip-feeding movement.

Needle bar stroke, 1-3/16 inches.

Presser bar lift, 3/16 inch.

Maximum stitch length, with regular fittings, 5-1/2 stitches per inch.

Needle, Catalog 1955

Speed, 5000 stitches per minute.

DESCRIPTION (continued)

281-30

Machine 281-29, Close-coupled Puller Feed

Light weight to medium weight fabrics.
Needle bar stroke, 1-13/64 inches.
Presser bar lift, 5/16 inch.
Maximum stitch length, with regular fittings, 5-1/2
stitch per inch.
Needle, Catalog 1955.
Close-coupled puller feed 1-9/16 inches behind
needle. Feed roll intermittently actuated from
an eccentric on the arm shaft
through a countershaft and linkage
to a combination one way clutch and
double bearing unit in the Feed
Roller. Eccentric is independently
adjustable to bring motion of the
feed roller in unison with motion
of feed dog. Lower roller is an
idler follower with a self-lubricated
core.
Speed: 5000 stitches per inch.

Machine 281-22, Needle Feed

Light weight to medium-heavy weight fabrics.
Needle bar stroke, 1-13/64 inches.
Presser bar lift, 5/16 inch.
Maximum stitch length, with regular fittings, 10
stitches per inch.
Needle, Catalog 1955.
Compound feed mechanism, consisting of needle
feed and drop feed, insures positive feeding of two
or more plies of material.
Improved stitch regulating mechanism. Needle feed
regulator can be locked to permit simultaneous ad-
justment of needle feed and drop feed.
Speed, 5000 stitches per minute.

Machine 281-23, Side-wheel Puller Feed

Light to medium weight fabrics.
Needle bar stroke, 1-13/64 inches.
Presser bar lift, 5/16 inch.
Maximum stitch length, with regular fittings, 5-1/2
stitches per inch.
Needle, Catalog 1955.
Side wheel feed roll independently adjustable to
bring motion of feed roll in unison with motion of
feed dog.
Speed, 5000 stitches per minute.

Machine 281-24 Needle Feed

Light to medium weight fabrics.
Needle bar stroke, 1-9/64 inches.
Presser bar lift, 9/32 inch.
Maximum stitch length, with regular fittings 10
stitches per inch.
Needle, Catalog 1361 (88x9)
Compound feed mechanism, consisting of needle
feed and drop feed, insures positive feeding of
two or more plies of material.
Improved stitch regulating mechanism. Needle feed
regulator can be locked to permit simultaneous
adjustment of needle feed and drop feed.
Speed, 5500 stitches per minute.

INSTALLATION

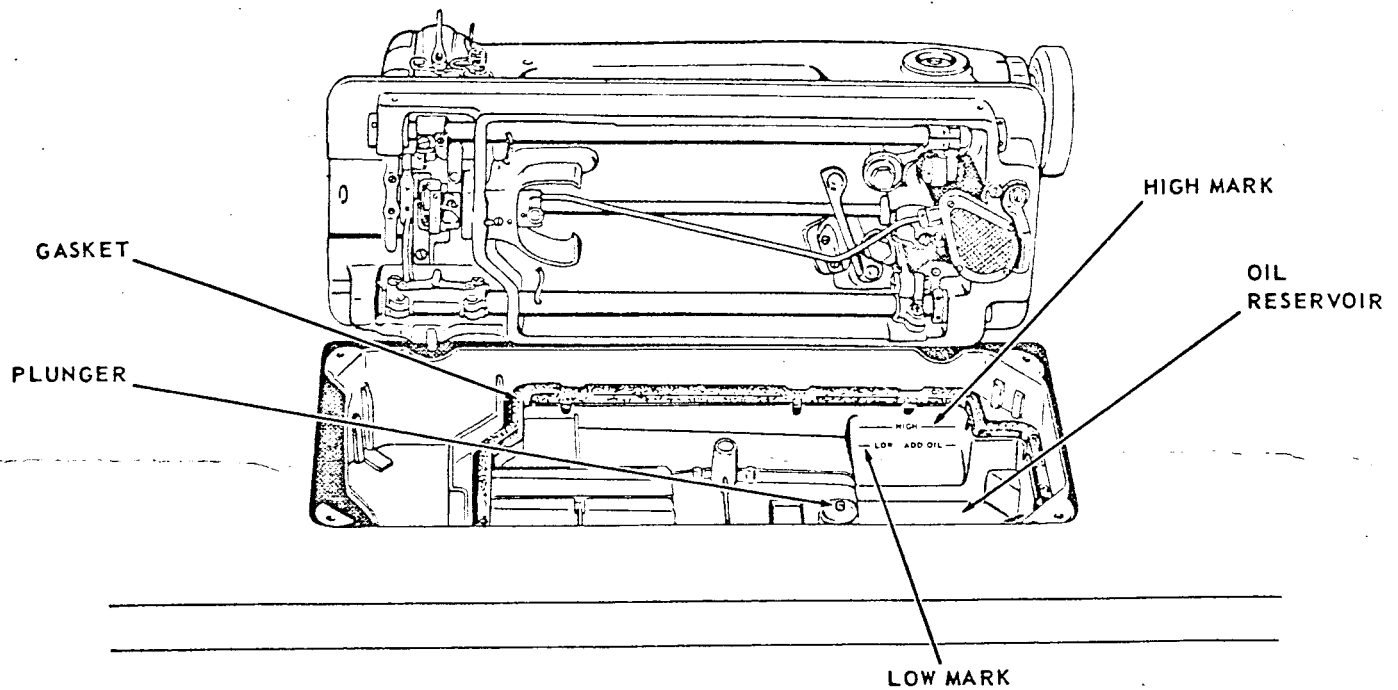

Fig. 2. Machine Base and Oil Reservoir

See that plunger is in place, as shown in Fig. 2, before placing machine on base.

Machine base and oil reservoir fits into standard table cut-out and rests on four corners without bolting. Rasp edges of cut-out, shown in Fig. 2, if necessary, so that machine does not touch table when placed on base.

Use shims on corners, when required to insure that base is level, so that oil level will be accurately indicated by marks on base.

Machine head is not fastened but should rest on cork gasket in base. Machine hinge pins must not support the head except when machine is tilted back.

THE KNEE LIFTER

Knee lifter is shipped assembled to the base except for the knee plate and lifter lever.

Loosen the two clamp screws shown in Fig. 3 and slide the rock shaft forward to position shown. Attach lifter lever.

Set the stop screw, Fig. 3, so that there is only a little play in the lever before it starts to lift the presser bar. Then tighten lock nut on stop screw.

Set the rear stop dog to allow the presser bar to be raised to its limit and tighten the two clamp screws.

CAUTION: Do not operate machine until it has been thoroughly lubricated in accordance with the following instructions.

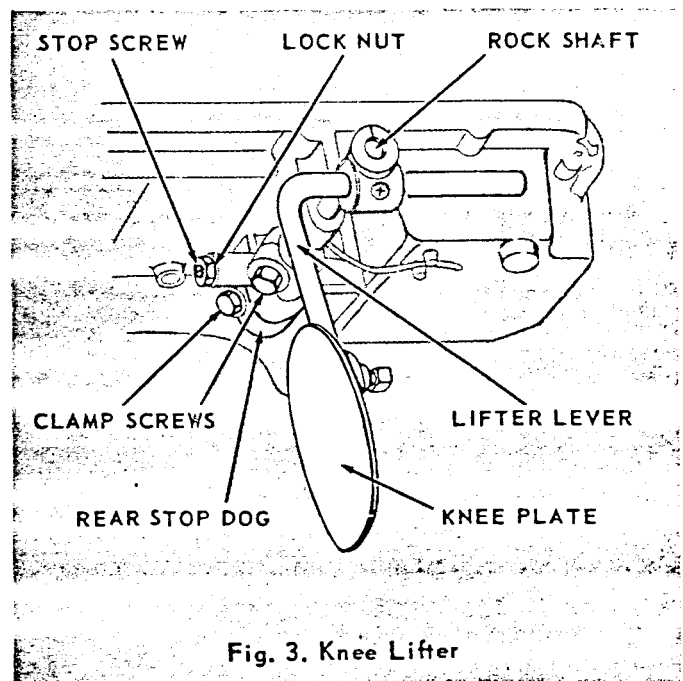

Fig. 3. Knee Lifter

LUBRICATION

Before starting machine, the oil reservoir must be filled to **HIGH MARK** shown in Fig. 2

Use SINGER OIL "TYPE A" or "TYPE C". Use "TYPE C" OIL when an oil is desired which will produce a minimum of stain on fabrics even after a long period of storage.

Do not use additives in sewing machine oil, as they may cause a reduction in normal oil flow that can result in damage to machine.

Should the oil flow, passing through the oil flow window as shown in Fig. 4, stop or become erratic, **STOP MACHINE AND DO NOT RUN AGAIN** until the cause has been eliminated.

Check oil level often to keep it from going below low mark.

The Oil Flow Regulator

Lubrication of the sewing hook is automatically controlled by the oil flow regulator shown in Fig. 5.

Regulator is set at the factory for lubrication under average sewing conditions.

To determine whether oil is properly flowing to the hook, run machine for approximately one minute to establish a uniform rate of flow. Then open the bed slide, hold a piece of paper under the hook and run the machine for about ten seconds. There should be a distinct line of oil on paper, beneath the hook bearing, with a fine spray on each side of this line.

If there is no trace of oil or an excess of oil on the paper, turn oil flow regulator to right or left to increase or decrease the flow of oil, as shown in Fig. 5.

Machine must run at least one minute between adjustments to insure uniform oil flow.

If the proper rate of flow cannot be obtained by turning the regulator, inspect the oil flow mechanism as follows:

Remove needle, bobbin and bobbin case from machine.

Remove bracket screw and position finger shown in Fig. 5.

Loosen two hook body screws and turn machine pulley until feed bar reaches its highest point.

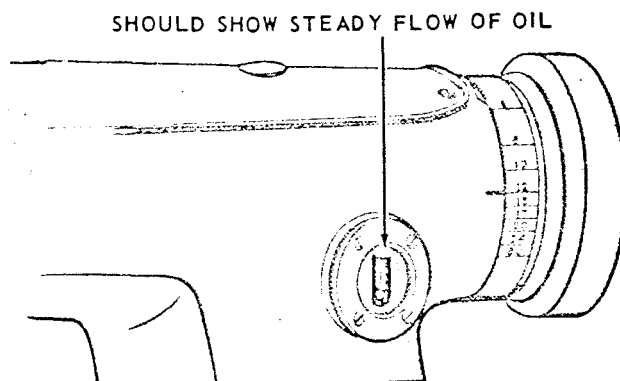

Fig. 4. Oil Flow Window

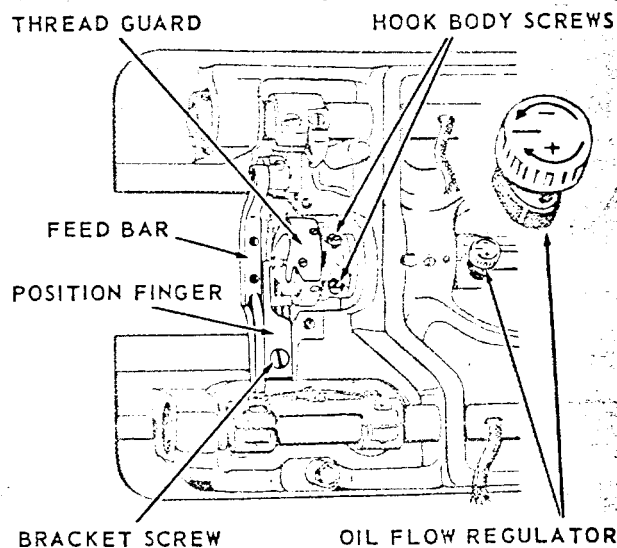

Fig. 5. Oil Flow Regulator

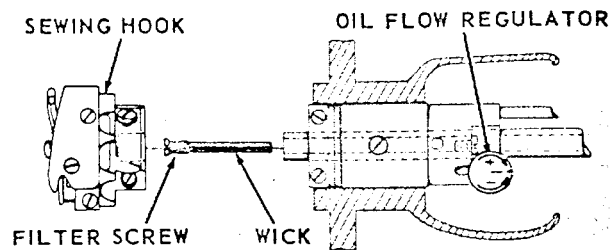

Fig. 6. Sewing Hook Filter Screw and Wick

Turn the sewing hook until thread guard is at the bottom as shown in Fig. 5 and slide hook from shaft. Loosen filter screw shown in Fig. 6 and check to see if wick has become detached or clogged.

Inspect all passages for dirt and lint accumulation. Replace wick if necessary.

Assemble sewing hook and position finger to machine.

Re-check oil flow as previously instructed.

CLEANING

Using a short bristle brush (not point of scissors or other sharp instrument), remove lint and other waste from around sewing hook, from between feed rows and underside of throat plate and from all other operating points.

Tilt machine back on hinges. Wrap clean rag around magnet, shown in Fig. 7, on oil pump body and pull accumulated foreign particles from magnet.

Wipe exterior of machine dry with a soft cloth.

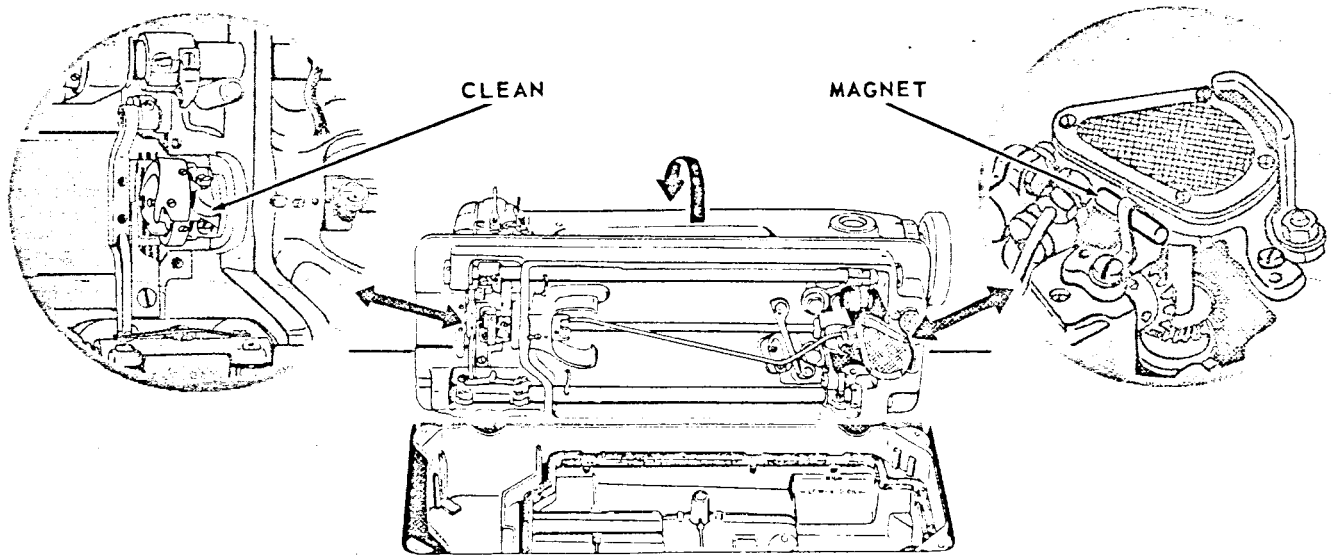

Fig. 7. Magnet on Oil Pump Body

SPEED

~~281-20~~
281-30

Maximum speed for Machines 281-5, 281-6, ~~281-20~~, 281-22 and 281-23 is 5000 stitches per minute.

Maximum speed for Machine 281-24 is 5500 stitches per minute.

It is advisable to operate new machines at a speed 500 stitches less than maximum for the first 100 hours of operation.

THREAD

Left twist thread should be used in needle.

Either right or left twist thread may be used in bobbin.

Thread twist is determined by holding thread as shown in Fig. 8 and twirling thread over toward you. If left twist, strands will wind tighter. If right twist, strands will unwind or separate.

Rough or uneven thread, or thread which passes through needle eye with difficulty, will interfere with successful operation of the machine.

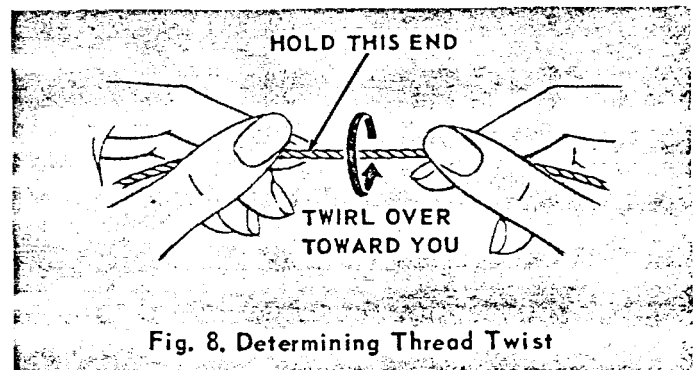

Fig. 8. Determining Thread Twist

NEEDLES

Machine 281-5

Use SINGER* Needle, Catalog 1515 (16x95), in sizes ranging from 11 to 22.

281-30

Machines 281-6, ~~281-20~~, 281-22 and 281-23

Use SINGER* Needle, Catalog 1955, in sizes ranging from 8 to 22.

Machine 281-24

Use SINGER* Needle, Catalog 1361, in sizes ranging from 8 to 22.

Size of needle to be used should be determined by weight of thread and type of material being sewn.

Orders for needles should specify quantity required, size number and catalog number.

For example:

100 No. 16, Catalog 1361 Needles

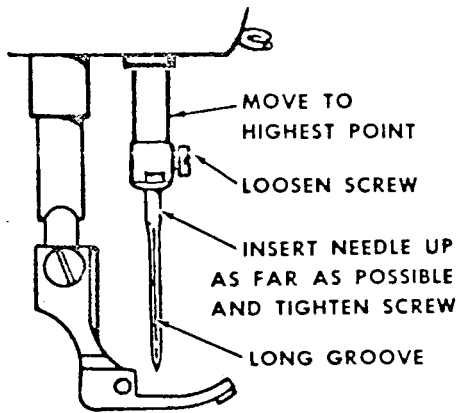

Fig. 9. Machine 281-5

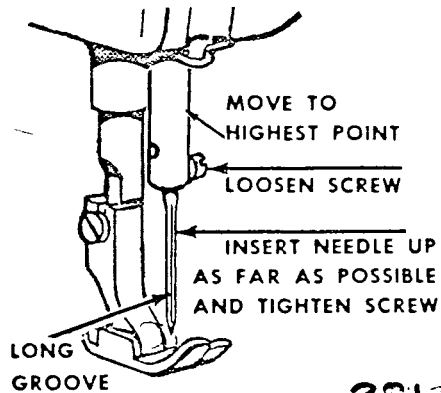

Fig. 10. Machines 281-6 and ~~281-20~~

281-30

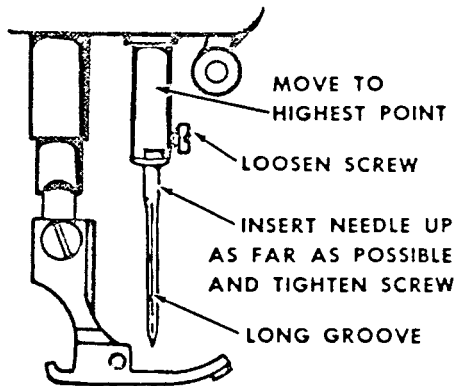

Fig. 11. Machines 281-22 and 281-24

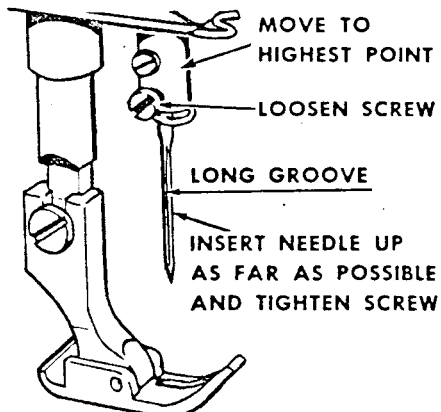

Fig. 12. Machine 281-23

SETTING THE NEEDLE

Turn machine pulley over toward operator until needle bar reaches highest point as shown in Figs. 9 to 12.

Loosen needle clamping screw. Insert needle into needle bar as far as it will go, with long groove of needle to the left and eye of needle directly in line with arm of machine. Then tighten the clamping screw.

UPPER THREADING

Turn machine pulley over toward operator until needle bar is at highest point.

Pass thread through threading points indicated in Figs. 13 to 18, page 9. Draw approximately two inches of thread through needle eye with which to start sewing.

UPPER THREADING

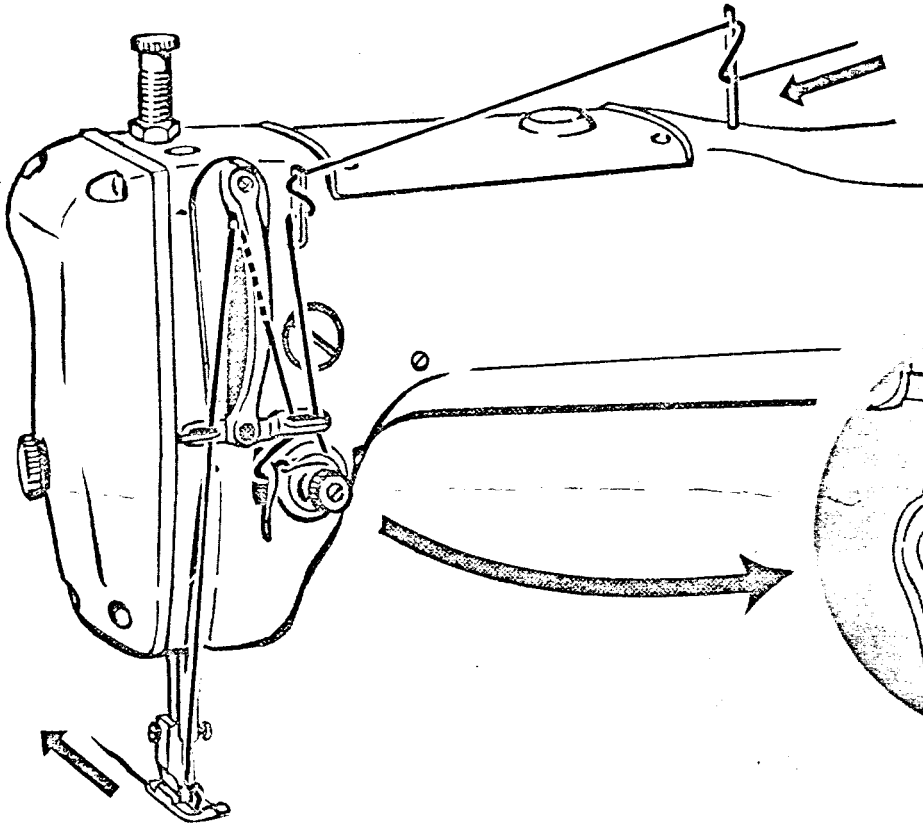

Fig. 13.

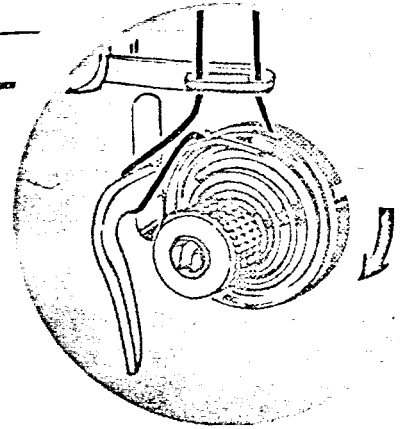

Fig. 14.

THREADING THE NEEDLE

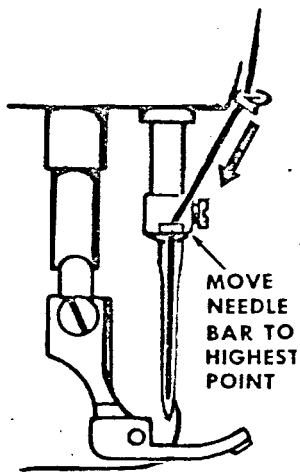

Fig. 15. Machine 281-5

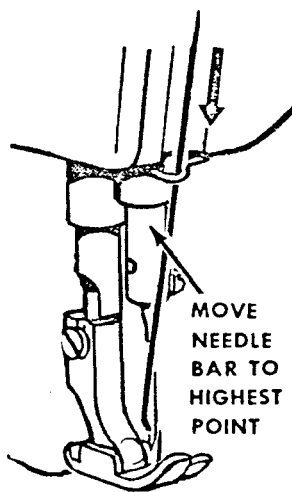

Fig. 16. Machines 281-6
and ~~281-20~~
281-30

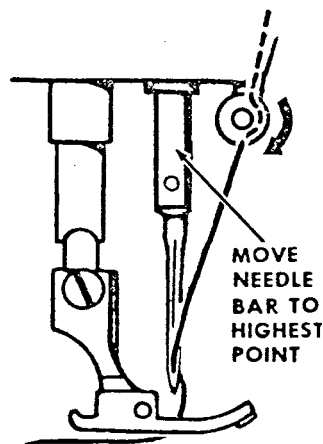

Fig. 17. Machines 281-22
and 281-24

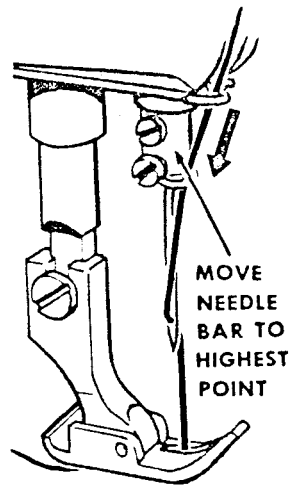

Fig. 18. Machine 281-23

LOWER THREADING

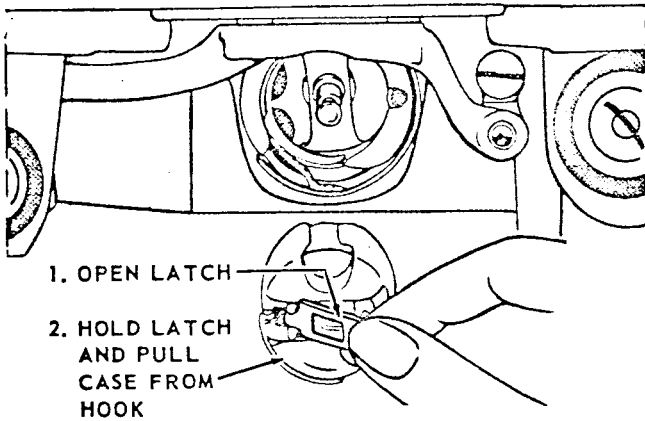

Fig. 19. Removing Bobbin Case

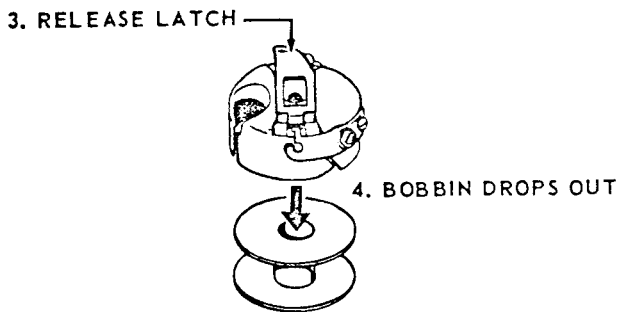

Fig. 20. Removing Bobbin

Bobbin Removal

Turn machine pulley over toward operator until needle bar is at highest point.

Reach beneath bed of machine with left hand and remove bobbin case from machine as shown in Fig. 19.

Release latch and bobbin will drop out of case, as shown in Fig. 20.

Threading Bobbin Case

Hold bobbin so that thread will unwind in the direction shown in Fig. 21. Hold bobbin case as shown and place bobbin into it.

Pull thread into slot and under tension spring, shown in Fig. 22, so that thread enters delivery eye at end of spring.

Bobbin Case Replacement

Place bobbin case on center stud of bobbin case holder and release latch. Place bobbin case back until latch catches near end of stud as shown in Fig. 23. Draw about two inches of thread from bobbin to start the sewing.

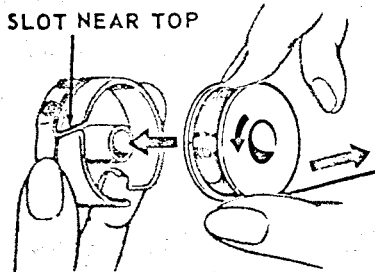

Fig. 21. Replacing Wound Bobbin

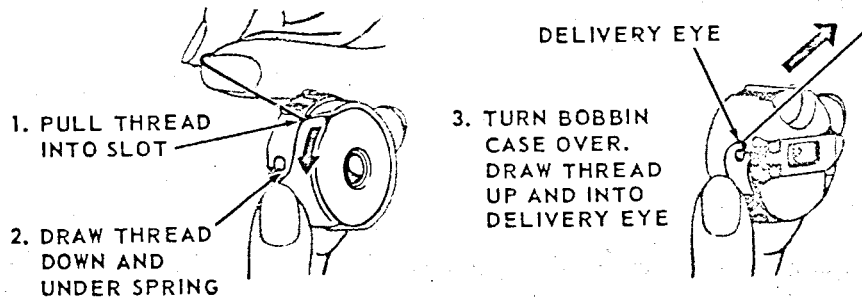

Fig. 22. Threading Bobbin Case

1. HOLDING LATCH, REPLACE BOBBIN CASE ON STUD.

2. RELEASE LATCH.

3. PRESS BACK, UNTIL LATCH CATCHES GROOVE IN STUD.

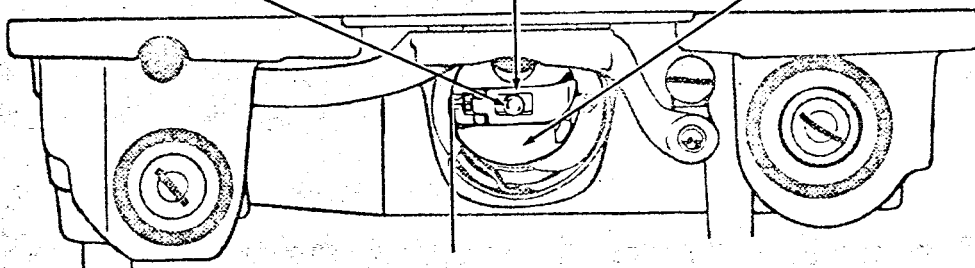

Fig. 23. Replacing Bobbin Case

ADJUSTING THE TENSION

Tension on thread should be as light as possible while still sufficient to set stitches correctly in material.

Regulate needle thread tension, as instructed in Fig. 24. Make certain presser foot is **DOWN** during tension adjustment.

Tighten lock nut to maintain tension adjustment.

Regulate bobbin thread tension as instructed in Fig. 25.

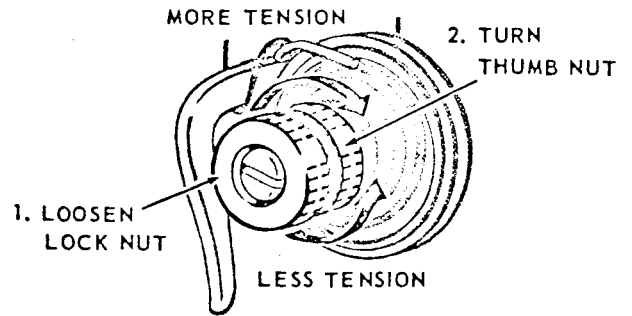

Fig. 24. Needle Thread Tension

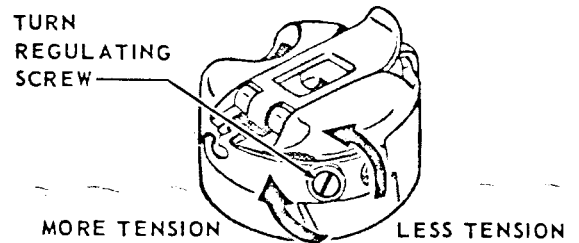

Fig. 25 Bobbin Thread Tension

ADJUSTING THE PRESSER FOOT PRESSURE

Correct presser foot pressure helps insure proper feeding of material.

Pressure should be as light as possible while still sufficient to insure correct feeding of material.

Regulate as instructed in Fig. 26, with presser foot down.

On all Machines, except Machine 281-5: Pressure regulating thumb screw is fitted with lock nut. Loosen this lock nut before adjusting pressure.

When correct pressure is obtained, tighten lock nut to maintain adjustment.

Machine 281-5: To adjust pressure, turn regulating screw (with screwdriver) upward for less pressure, or downward for more pressure, as required.

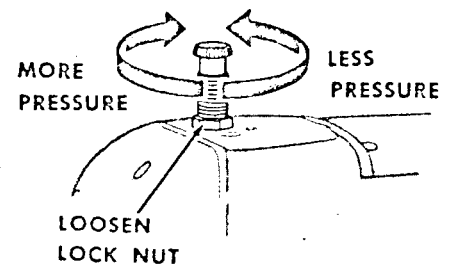

Fig. 26. Presser Foot Pressure

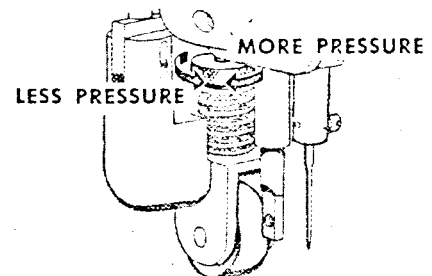

Fig. 27. Regulating Pressure of ~~281-20~~ **281-30** Roller Presser on Machine ~~281-20~~

ADJUSTING THE PRESSURE OF THE ROLLER PRESSERS (MACHINES ~~281-20~~ AND 281-23)

281-30

Pressure of the roller pressers on these machines should be as light as possible, while still sufficient to insure correct feeding.

Regulate as instructed in Figs. 27 and 28.

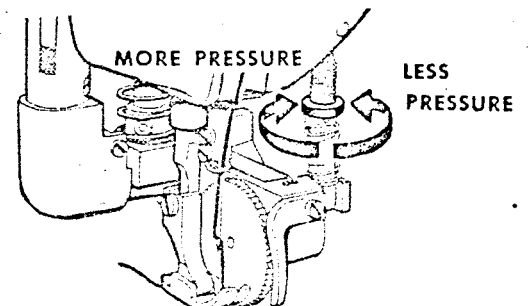

Fig. 28. Regulating Pressure of Roller Presser on Machine 281-23

REGULATING THE STITCH LENGTH

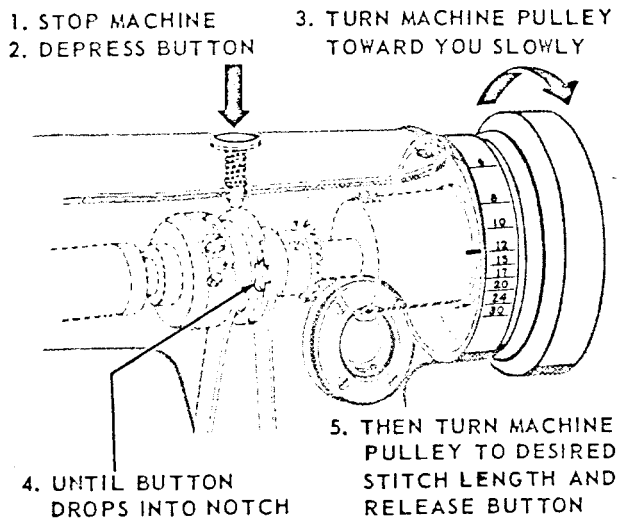

Fig. 29. Machine 281-5

Changes in stitch length should never be attempted while the machine is running.

See pages 3 and 4 for information on maximum stitch length for your machine.

CAUTION: Stitch length setting should never exceed capacity of fittings in use.

Machine 281-5

Regulate the stitch length, as instructed in Fig. 29.

Button mentioned in Step 4, Fig. 29, drops into notch with an audible click.

Machine 281-6

1. Remove needle from machine.
2. Depress feed dog stitch length button, shown in Fig. 30.
3. Turn machine pulley over toward-you until button drops (audible click).
4. Turn machine pulley to desired stitch length and release button.
5. Depress top-gripper stitch length button.
6. Turn machine pulley toward you slowly-until button drops.
7. Turn machine pulley to same stitch length as feed dog is set.

Never depress either button while machine is running. Make certain both buttons are disengaged before starting machine.

281-30

Machines ~~281-20~~ and 281-23

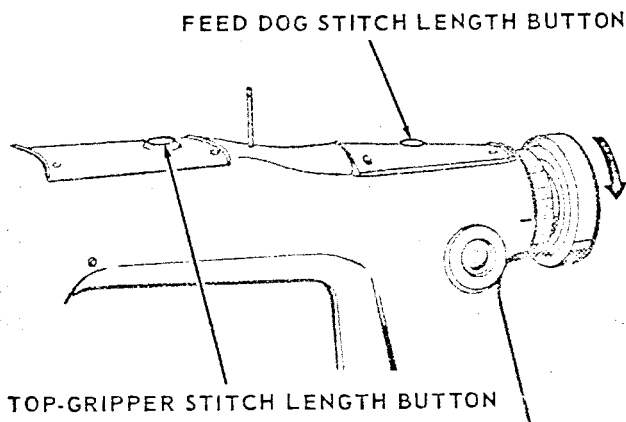
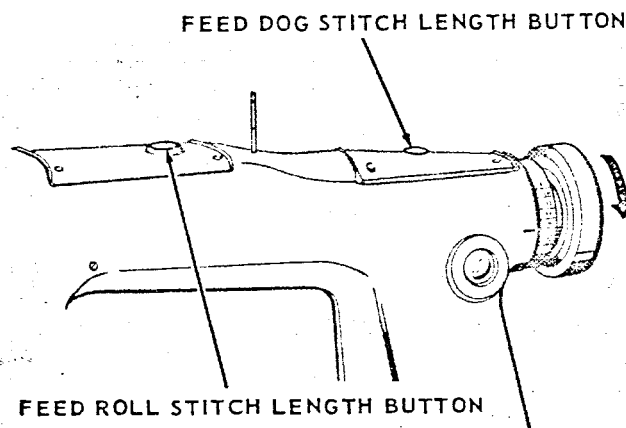

Fig. 30. Machine 281-6



281-30
Fig. 31. Machines ~~281-20~~ and 281-23

1. Stop machine.
2. Depress feed dog stitch length button, shown in Fig. 31.
3. Turn machine pulley over toward you slowly-until button drops (audible click).
4. Turn machine pulley to desired stitch length and release button.
5. Depress feed roll stitch length button.
6. Turn machine pulley toward you slowly-until button drops.
7. Turn machine pulley to desired stitch length and release button.

Never depress either button while machine is running. Make certain both buttons are disengaged before starting machine.

REGULATING THE STITCH LENGTH (continued)

Machines 281-22 and 281-24

1. Remove needle from machine.
2. Depress plunger, shown in Fig. 32, on top of arm. Continue to hold plunger down - - -
3. Turn machine pulley over toward you - - - until plunger drops (entering notch in arm shaft eccentric).
4. Turn plunger, toward right or left, 1/4 turn, to lock position.
5. Depress stitch length button, shown in Fig. 32.
6. Turn machine pulley over toward you - - - until button drops.
7. Turn machine pulley to desired stitch length and release button.
8. Turn plunger toward right or left until it releases, springing upward.

TO PREVENT JAMMING OF MACHINE: PLUNGER MUST ALWAYS BE DISENGAGED BEFORE STARTING MACHINE.

Never depress either button or plunger while machine is running.

Never turn machine pulley with plunger in locked position unless stitch length button is depressed also.

PREVENTING UNAUTHORIZED CHANGES IN STITCH LENGTH

Stitch regulator button may be removed by loosening the arm top cover screws and removing arm top cover, as shown in Fig. 33.

Remove retaining ring near tip of button allowing button to be withdrawn.

Hole in top cover should then be filled by inserting plug screw 140607 which may be obtained at additional charge.

Replace arm top cover.

TO OPERATE THE TRIMMER (MACHINE 281-5)

To engage the vertical trimmer, push **DOWN** on lever, shown in Fig. 34.

To raise the knife out of the way, push **IN** button on face, as shown.

FROM THIS POINT ON, INSPECT AND ADJUST THE MACHINE, WHEN IT IS REQUIRED, IN THE ORDER GIVEN.

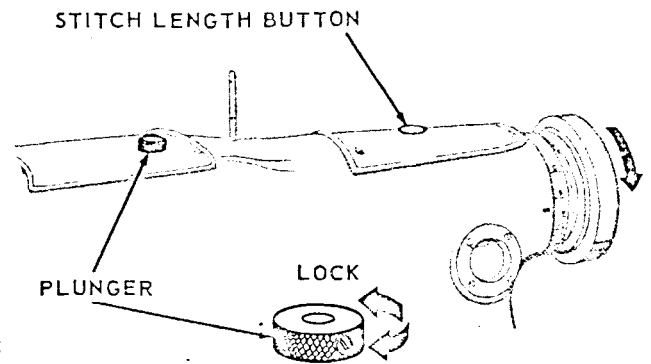

Fig. 32. Regulating the Needle Feed and Drop Feed, Machines 281-22 and 281-24

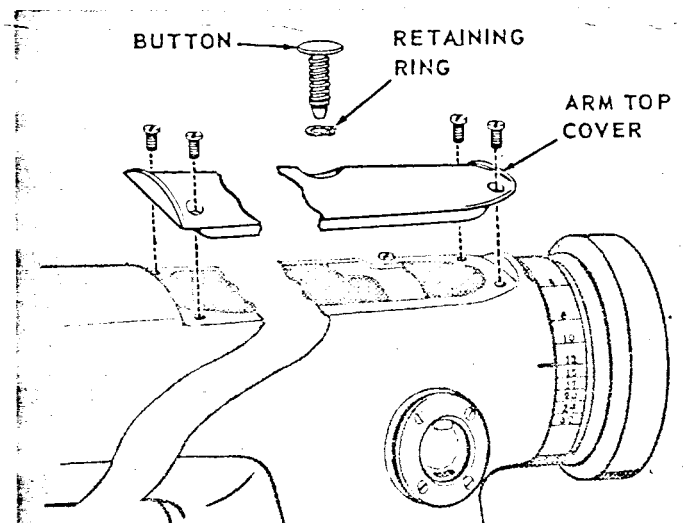

Fig. 33. Removing Stitch Length Regulator Button

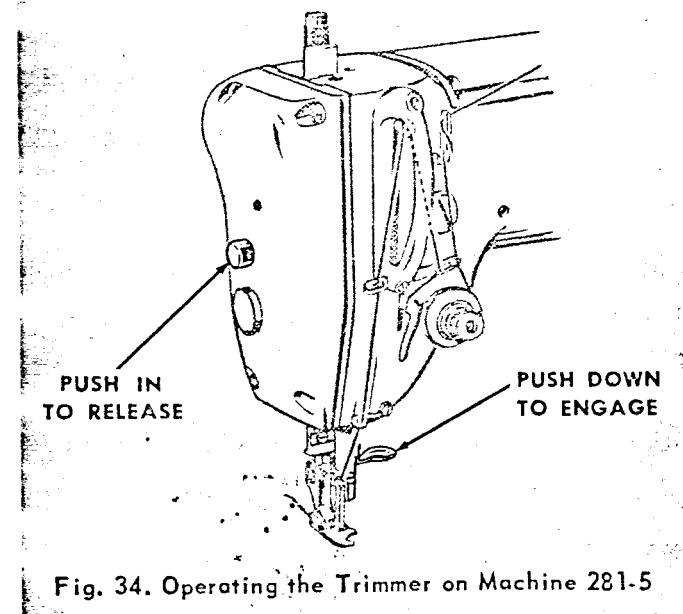

Fig. 34. Operating the Trimmer on Machine 281-5

THE FACE PLATE (MACHINE 281-5)

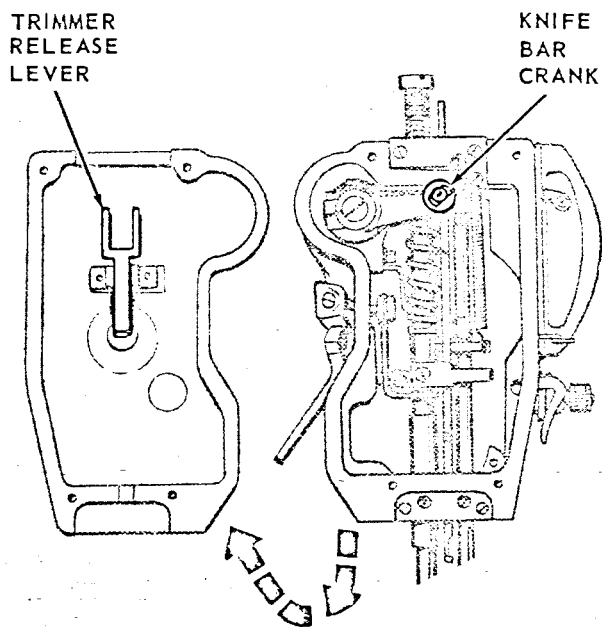

Fig. 35. Removing the Face Plate
(Machine 281-5)

The specialized face plate on machine 281-5 requires a small amount of manipulation to be safely removed and replaced. When correctly placed the trimmer release lever is hooked under the knife bar crank shown in Fig. 35.

Face plate may be removed by loosening its four screws and gently pulling face plate outward to separate gasket from casting. Then draw face plate downward to disengage release lever from knife bar crank shown in Fig. 35.

Replace face plate with an upward motion so that release lever is engaged beneath knife bar crank. Make certain that screw holes in gasket align with their respective screw holes in face plate. Securely tighten the four face plate screws.

POSITIONING NEEDLE CORRECTLY IN NEEDLE HOLE OF THROAT PLATE CUTTING BAR (MACHINE 281-5)

Turn machine pulley until needle point rises just above needle hole in throat plate cutting bar.

Loosen the two screws B, Fig. 36 and locate throat plate so that needle will rise and fall in center of needle hole in throat plate cutting bar.

Tighten the two screws B.

SETTING THE TRIMMING MARGIN (MACHINE 281-5)

The distance from the trimmed edge to the line of stitching is determined by the throat plate cutting bar used. Each throat plate cutting bar is designed for but one trimming margin. (See "DESCRIPTION" on page 3.)

The trimming margin is measured from the center of the needle hole to the cutting edge of the throat plate cutting bar.

To change trimming margin: Loosen slide screw and move throat plate slide, shown in Fig. 36, toward the right. Remove two screws A, Fig. 36 and presser foot screw. Change throat plate cutting bar and presser foot as required, fastening cutting bar with two screws A. Return throat plate slide to its normal position (toward the left against cutting bar) and tighten slide screw.

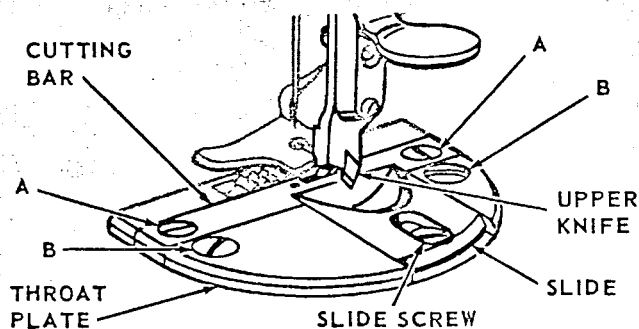

Fig. 36. Needle Location in Throat Plate
Cutting Bar (Machine 281-5)

After changing trimmer parts, always check knife adjustment, as instructed on page 15.

SETTING UPPER KNIFE IN RELATION TO THE THROAT PLATE CUTTING BAR (MACHINE 281-5)

Press down on lever shown in Fig. 37, lowering knife.

Turn machine pulley until upper knife is at its lowest position.

Loosen the two lock nuts behind screws shown in Fig. 37, above upper knife. Move knife holder to bring upper knife as close as possible to cutting bar, as shown. Securely tighten two screws and lock nuts, previously loosened.

Loosen two screws B, Fig. 37. Using a screwdriver as shown, press throat plate cutting bar firmly against upper knife, setting cutting bar parallel to blade of knife, as shown in Fig. 37. Securely tighten two screws B.

Check to make certain upper knife releases readily when button on face plate is pushed IN.

Recheck needle location in cutting bar needle hole and re-set, if necessary as instructed at bottom of page 14. Then check and re-set upper knife as instructed above.

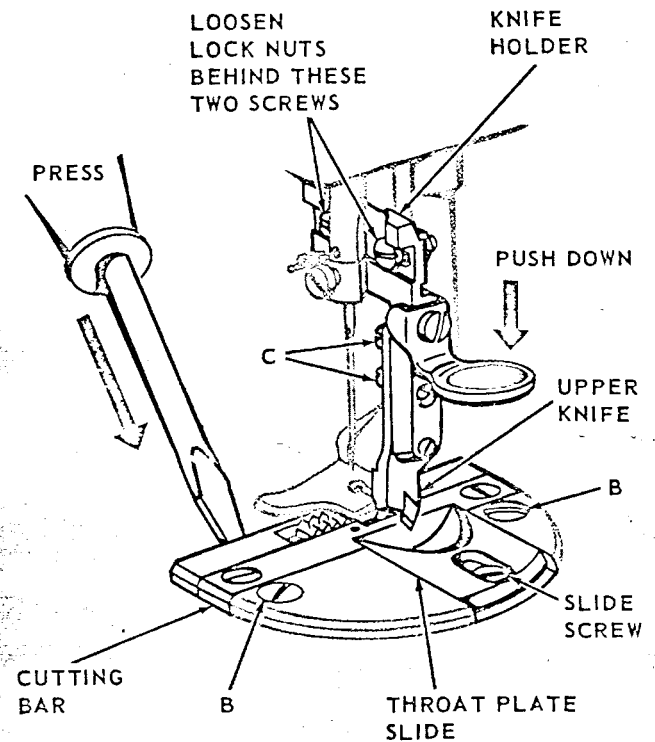

Fig. 37. Setting Knife in Relation to Cutting Bar on Machine 281-5

TO ADJUST HEIGHT OF KNIFE (MACHINE 281-5)

Turn machine pulley over toward you until upper knife is at its lowest position. Loosen two screws C, Fig. 37. Raise or lower the upper knife as required to bring highest point of cutting edge approximately 1/64 inch below top surface of throat plate cutting bar. Securely tighten two screws C.

CAUTION: Make certain that upper knife does not strike throat plate slide. Loosen slide screw and move slide, as required. Slide should be closed without coming in contact with knife.

Care must be taken to keep both knives sharp.

SHARPENING THE UPPER KNIFE (MACHINE 281-5)

When sharpening the upper knife, make certain that 10° bevel shown in Fig. 38 is maintained, to insure correct engagement of upper and lower knives.

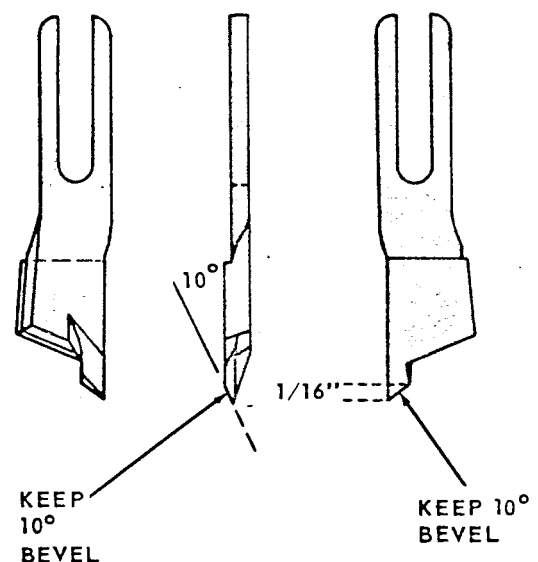

Fig. 38. Sharpening Knife on Machine 281-5

POSITIONING NEEDLE IN RELATION TO THROAT PLATE
AND FEED DOG (MACHINES 281-22 AND 281-24)

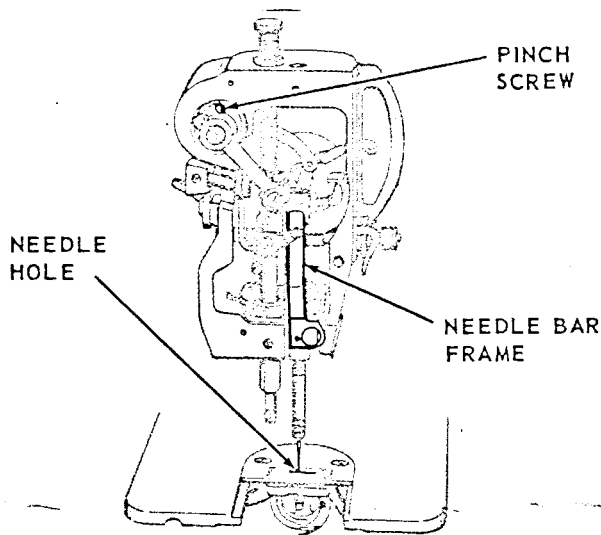

Fig. 39. Positioning the Needle (front to rear) on Machines 281-22 and 281-24

Needle should not contact surfaces of throat plate or feed dog.

Needle, needle bar and needle bar frame may be positioned forward or backward, after loosening pinch screw, shown in Fig. 39.

To adjust, set feed eccentrics for longest stitch, as instructed on page 13. Insert needle correctly in needle bar. Remove face plate and slide plate.

Loosen pinch screw and move needle bar frame, as required. Securely tighten pinch screw and replace all parts previously removed.

SETTING THE LOWER NEEDLE BAR BUSHING

ON COMPOUND FEED MACHINES 281-22 AND 281-24: The lower needle bar bushing is integral with the needle bar frame and does not require separate setting.

ON ALL OTHER MACHINES: Gauge distance from throat plate seat to bottom of lower needle bar bushing is 2.599 inches.

Raise or lower needle bar bushing, as required to obtain correct height setting, after loosening bushing set screw shown in Fig. 40.

SETTING THE NEEDLE BAR HEIGHT
(without using timing mark)

Machine 281-5: Remove bed raising plate.

All Machines: Remove face plate, slide plate and throat plate.

When needle bar is at its lowest point (during rotation of machine pulley), the gauge distance from throat plate seat to needle stop in needle bar, as shown in Fig. 41, is - - -

- 0.866 inch for Machine 281-24
- 1.031 inches for all other Machines.

To set needle bar height, loosen the needle bar clamping screw shown in Fig. 41. Raise or lower needle bar as may be required. Securely tighten clamping screw. Replace all parts previously removed.

When replacing face plate, make certain that screw holes in gasket align with screw holes in face plate, to avoid injury to gasket and subsequent oil leakage.

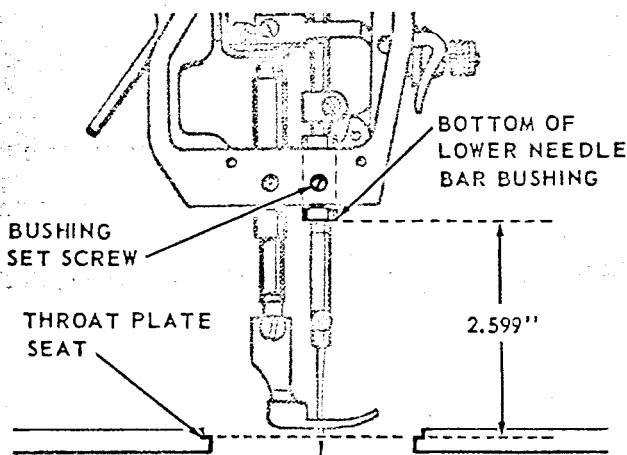

Fig. 40. Correct Setting: Needle Bar Bushing

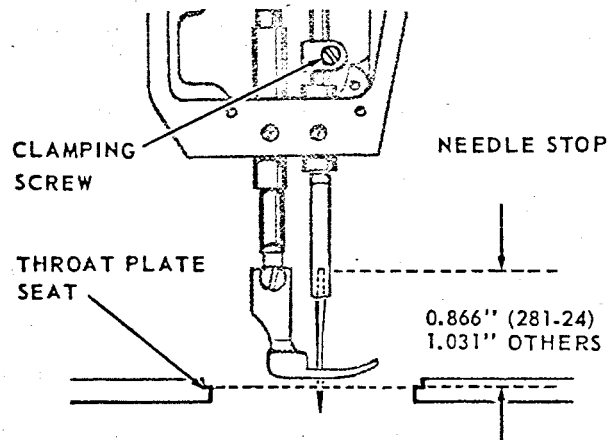

Fig. 41. Setting Needle Bar at Correct Height (Using Gauge Distance)

SETTING THE TIMING-INDICATOR PIN (MACHINES 281-22 AND 281-24)

Set needle bar at correct height, as instructed on page 16.

When needle bar is at its lowest point (during rotation of machine pulley) the point of timing indicator pin should be level with UPPER TIMING MARK on needle bar, as shown in Fig. 42.

To adjust indicator pin, loosen set screw, shown in Fig. 42, in needle bar frame and raise or lower pin, as required. Securely tighten set screw.

SETTING THE NEEDLE BAR HEIGHT (Using Upper Timing Mark)

When lower needle bar bushing (or timing-indicator pin on Machines 281-22 and 281-24) is correctly set as previously instructed, the timing marks on the needle bar may be used for setting and timing the machine. If needle bar height is subsequently disturbed, needle bar may be quickly restored to its correct height as follows - - -

MACHINES 281-22 AND 281-24: Turn machine pulley slowly until needle bar is at its lowest point. Loosen needle bar clamping screw shown in Fig. 42, and raise or lower needle bar, as required, to bring UPPER TIMING MARK level with pointer on timing-indicator pin, as shown in Fig. 42. Securely tighten clamping screw.

ALL OTHER MACHINES: Turn machine pulley slowly until needle bar is at its lowest point. Loosen needle bar clamping screw, shown in Fig. 43, and raise or lower needle bar, as required, to bring UPPER TIMING MARK level with bottom of lower needle bar bushing, as shown in Fig. 43. Securely tighten clamping screw.

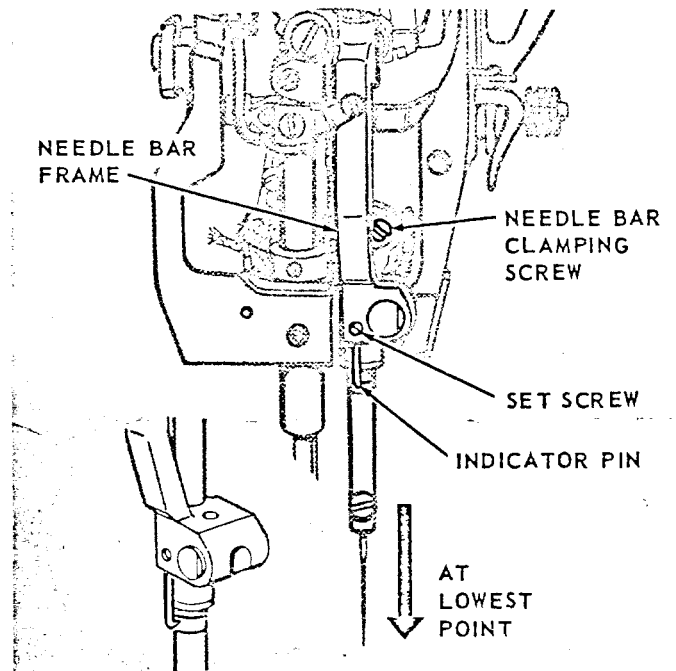

Fig. 42. Setting Needle at Correct Height on Machines 281-22 and 281-24

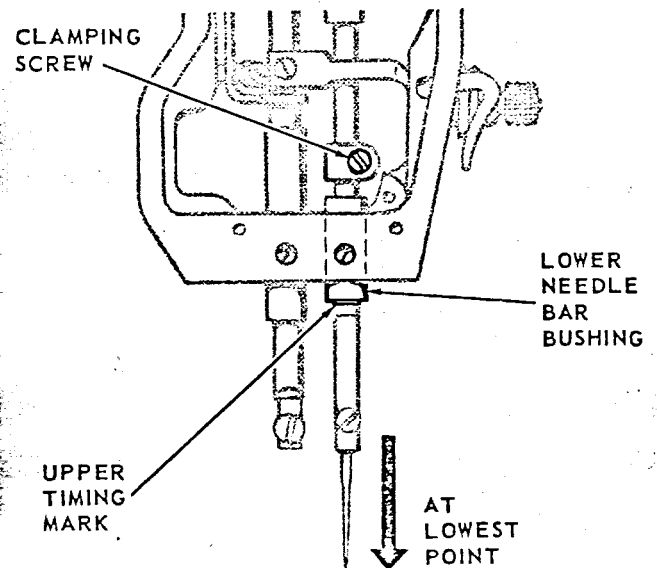

Fig. 43. Setting Needle Bar at Correct Height on all Machines, except 281-22 and 281-24

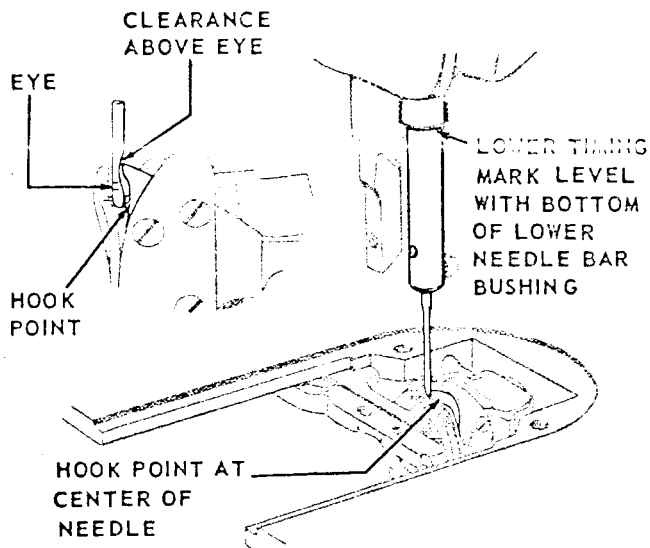

Fig. 44. Hook Point at Center of Needle

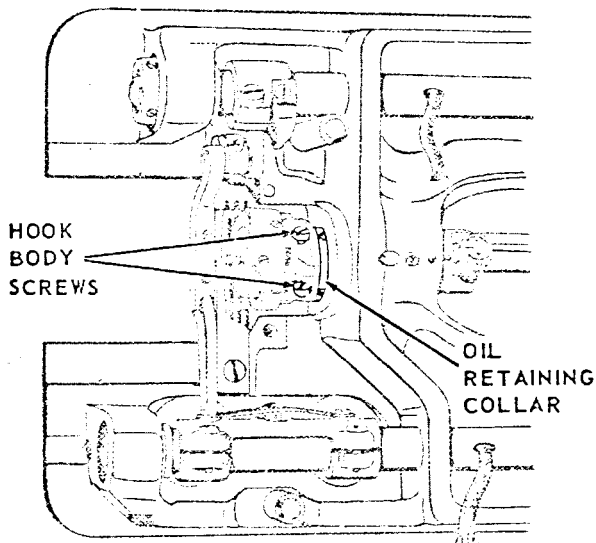

Fig. 45. Hook Body Screws

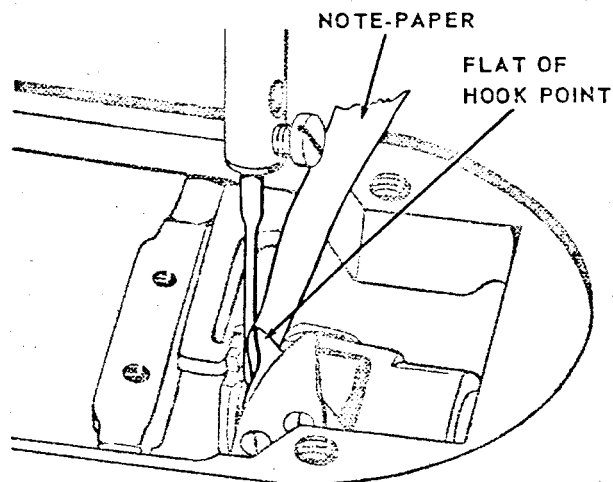

Fig. 46. Clearance Between Needle and Hook

TIMING THE MACHINE

Timing the machine consists of first adjusting the radial position of sewing hook with relation to movement of needle bar and needle thread take-up lever, to make certain that loop of thread formed by needle will be correctly taken by point of hook at proper time.

The check spring and feed are then timed to synchronize their motions with needle and hook movement.

TIMING THE SEWING HOOK

MACHINE 281-5: Remove bed-raising plate.

MACHINES 281-22 AND 281-24: Make certain that timing-indicator pin is correctly set in needle bar frame, as instructed on page 17.

ALL MACHINES: Remove slide plate, throat plate, presser foot and feed dog.

Turn machine pulley over toward operator until needle bar reaches its lowest point and rises to position where **LOWER TIMING MARK** on needle bar is level with bottom of lower needle bar bushing, as shown in Fig. 44. (On Machines 281-22 and 281-24, **LOWER TIMING MARK** should be level with timing-indicator pin shown in Fig. 42, page 17).

At this position, point of sewing hook should be at center of needle, as shown in inset, Fig. 44.

Loosen two hook body screws shown and turn hook on shaft as required to bring point of hook to center of needle. See Fig. 45.

Make certain that hub of hook is against oil retaining collar and tighten hook body screws.

Check clearance between needle and hook point, in accordance with the following instructions.

SETTING THE CLEARANCE BETWEEN NEEDLE AND HOOK POINT

MACHINE 281-5: Remove bed-raising plate.

ALL MACHINES: Remove slide plate, throat plate and bobbin case.

Check to see that needle is properly seated in needle bar and time sewing hook as previously instructed.

Point of sewing hook should pass needle as closely as possible without striking or deflecting needle. A clearance of about the thickness of a piece of note paper (approximately .005 inch), as shown in Fig. 46, is sufficient.

SETTING THE CLEARANCE BETWEEN NEEDLE AND HOOK POINT (Continued)

To move hook point toward or away from needle, loosen the two bevel gear screws shown in Fig. 47 and loosen bushing set screw shown in Fig. 48.

MAKE CERTAIN THAT BEVEL GEARS ARE KEPT IN MESH CONSTANTLY UNTIL THEIR SCREWS ARE SECURELY RETIGHTENED.

Using a light mallet and a 1/4 inch brass drift pin, move hook assembly toward or away from needle as required. Figs. 48 and 49 show correct placement of drift pin. **TAP VERY LIGHTLY** to avoid damaging hook assembly.

Securely tighten bushing set screw.

Remove all end play from hook shaft by moving hook assembly firmly against front hook shaft bushing and, at the same time, moving hook shaft bevel gear toward sewing hook end of shaft.

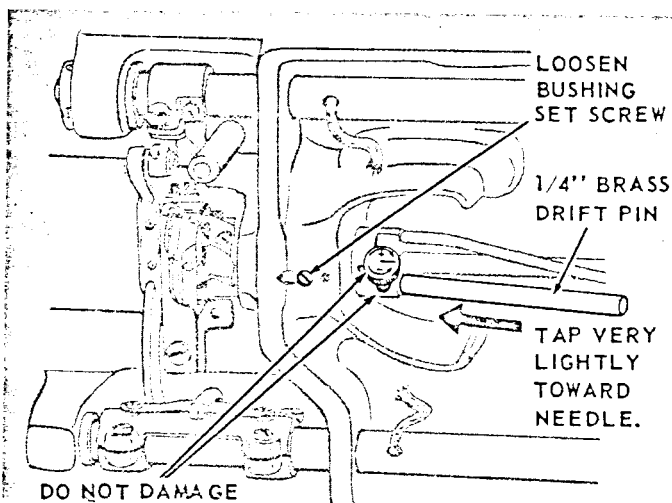

Fig. 48. Position of Drift Pin when Moving Hook Toward Needle

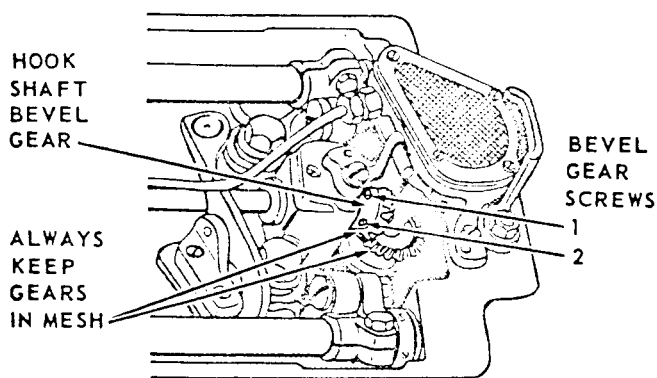

Fig. 47. Bevel Gear Screws

Tighten screw 1, Fig. 47 on bevel gear. Securely tighten bevel gear screw 2, Fig. 47.

Replace all parts previously removed.

Check thread clearance between position finger and bobbin case, as instructed next.

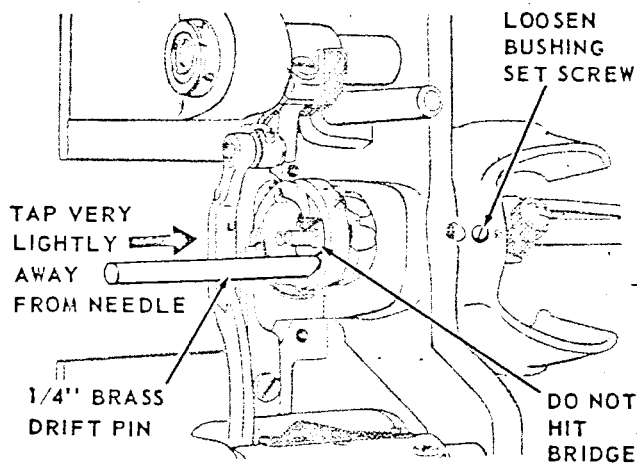

Fig. 49. Position of Drift Pin when Moving Hook Away from Needle

SETTING THE POSITION FINGER

Clearance between position finger and bobbin case holder should be just sufficient to allow thread to pass through easily. Normally an .018 to .022 inch clearance, as shown in Fig. 50, is required. If necessary, bend position finger **CAREFULLY** to achieve this setting.

Top surface of the position finger must be kept level with the top surface of the bobbin case holder.

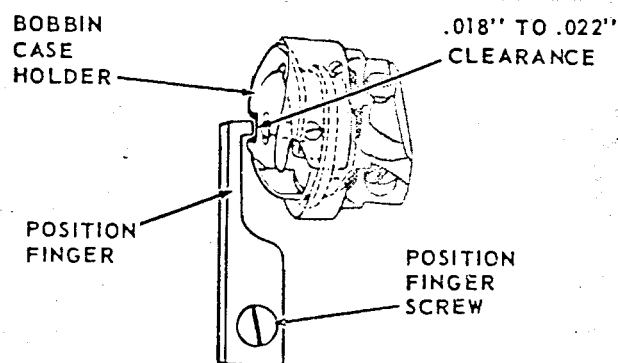

Fig. 50. Position Finger

STRINGING THE NEEDLE GUARD

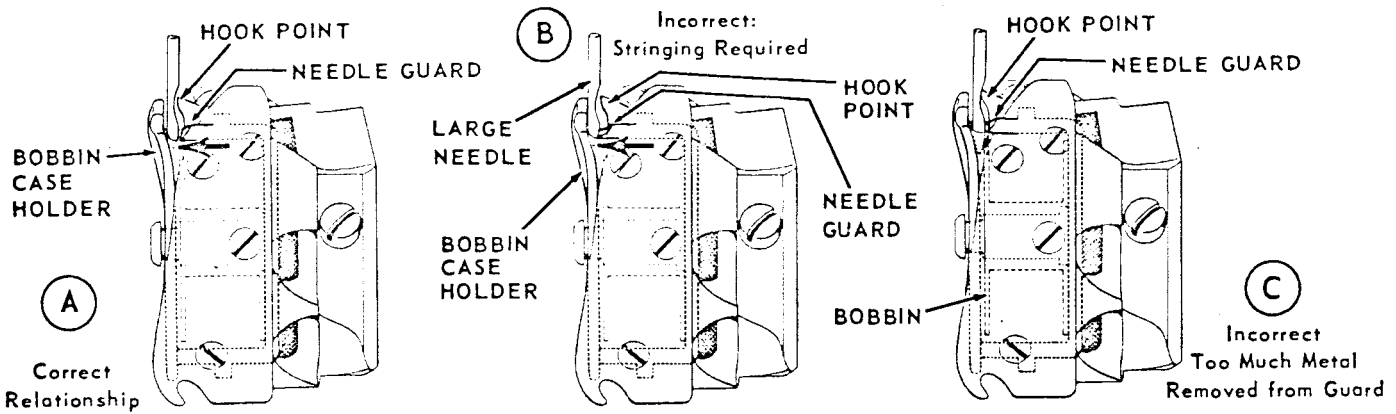

Fig. 51. Needle Guard at Loop-Taking Time

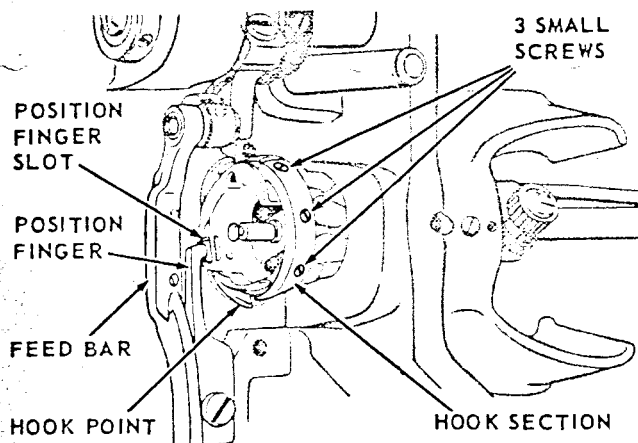

Fig. 52. Hook Section

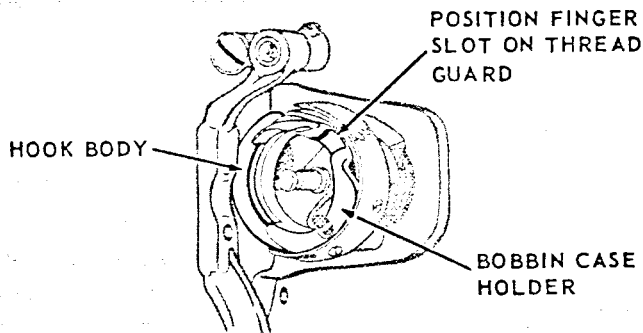

Fig. 53. Bobbin Case Holder

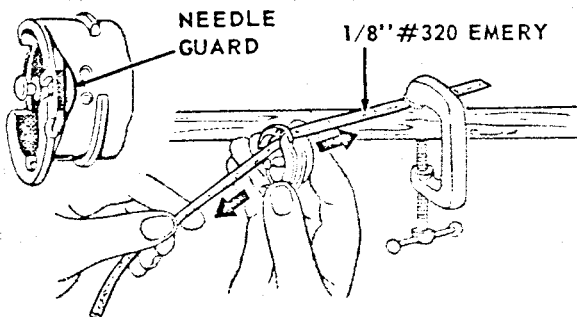

Fig. 54. Stringing Needle Guard

The needle guard on the bobbin case holder, shown in Figs. 51 and 54, should prevent needle from contacting hook or bobbin case at any time. See Fig. 51 (A) for correct relationship. When large needles (size 20 or larger) are used, needle guard may deflect needle too far toward left resulting in damage to needle. See Fig. 51 (B). To avoid this, it may be necessary to string the needle guard in accordance with the following instructions.

MACHINE 281-5: Remove bed-raising plate.

ALL MACHINES: Remove needle, slide plate, throat plate and bobbin case from machine

Turn machine pulley until feed bar, Fig. 52, is at its highest point.

Remove position finger shown in Fig. 52.

Turn hook body to position shown in Fig. 52 and remove three small screws and hook section shown.

Turn bobbin case holder until position finger slot on thread guard is at location shown in Fig. 53. Slip bobbin case holder out of hook body.

Remove a slight amount of metal from needle guard by rubbing needle guard along a 1/8 inch strip of very fine emery cloth, as shown in Fig. 54.

EXTREME CARE should be taken to avoid removal of too much metal as this may permit needle to strike hook. See Fig. 51 (C). Bobbin case holder will then need replacement.

Clean bobbin case holder thoroughly before replacing it in hook body.

Replace all parts in reverse order instructed for removal.

SETTING THE CHECK SPRING HEIGHT

Thread the machine. Turn machine pulley over slowly toward operator, observing check spring shown in Fig. 55.

When take-up lever begins to rise, check spring should make a slight dip and return to its higher position.

As take-up lever approaches top of its stroke, setting the stitch, check spring should be drawn all the way down.

As take-up lever descends, check spring should return to rest.

To increase or decrease height of check spring (which respectively increases or decreases its movement), loosen stud set screw shown in Fig. 55. Turn stud, along with entire check spring assembly, to set check spring height as required. Securely tighten set screw.

NOTE: Height setting should be checked each time a different presser foot is used with machine.

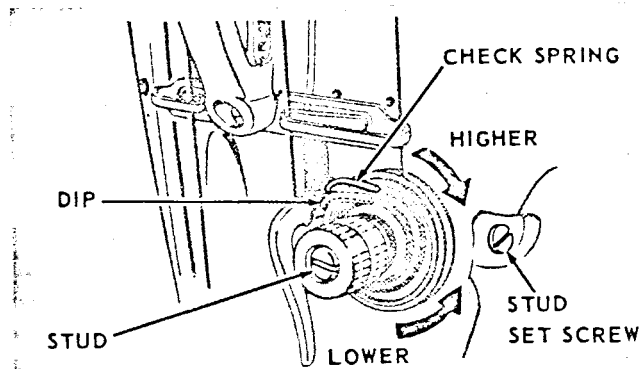

Fig. 55. Check Spring

SETTING THE CHECK SPRING TENSION

Tension on check spring should be sufficient to insure action at top speed but light enough to allow check spring to be drawn all the way down.

To adjust, first make certain that stud set screw shown in Fig. 55 is securely tightened. Then, using a screwdriver in slot of stud, turn stud alone toward left to decrease tension, or toward right to increase tension.

CENTRALIZING THE FEED DOG

Feed dog should never contact edges of throat plate but should move midway between sides of throat plate slots and maintain its movement equidistant from front and rear edges of throat plate slots.

Sidewise Setting

To move feed dog toward left or right, loosen the two clamp screws on feed bar carrier and the clamp screw on feed bar crank, shown in Fig. 56.

Move feed bar as required to position feed dog midway between sides of throat plate slots.

Make certain that feed dog height is correct as instructed on page 22.

Securely tighten all three clamp screws.

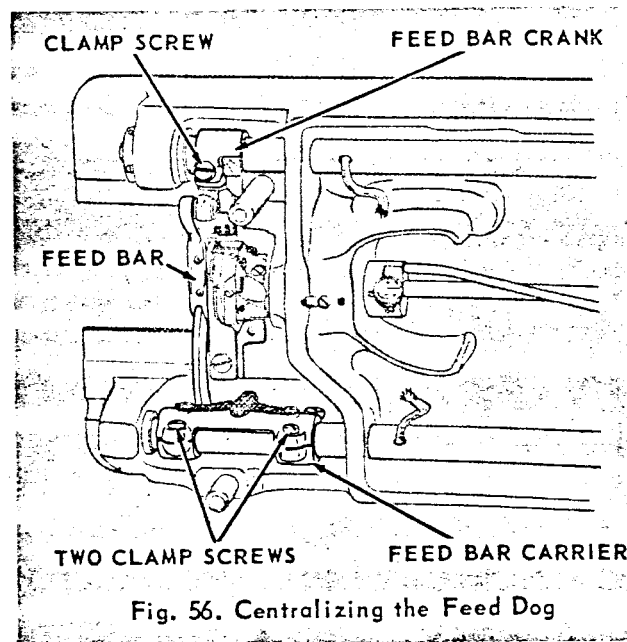

Fig. 56. Centralizing the Feed Dog

CENTRALIZING THE FEED DOG (Continued)

Lengthwise Setting

Set machine for longest stitch and loosen hex-head screw, shown in Fig. 57, on rock shaft.

Move feed bar carrier and rock shaft so that movement of feed dog is equidistant from front and rear

edges of throat plate slots.

Securely tighten hex-head screw.

Check linkage for freedom of movement to reduce wear and insure maximum efficiency.

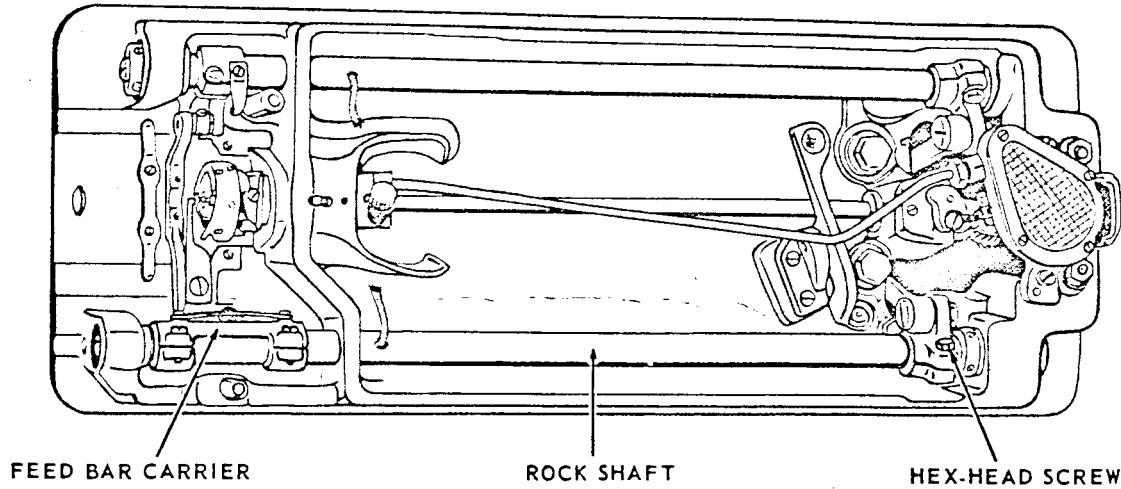

Fig. 57. Feed Bar Linkage

SETTING THE FEED DOG HEIGHT

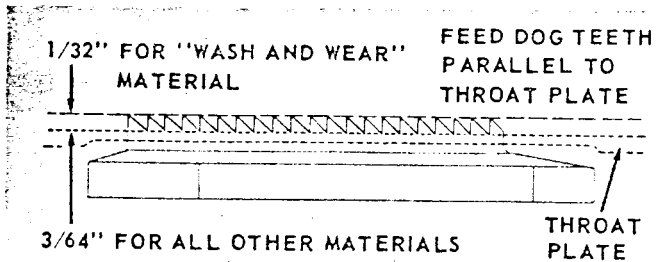

Fig. 58. Correct Height of Feed Dog

Feed dog height should be adjusted with machine set for longest stitch, ALL the teeth of the feed dog should rise equally high above the throat plate, as shown in Fig. 58.

The correct height of feed dog for wash and wear fabrics is 1/32 inch above throat plate.

For all other fabrics the correct height is 3/64 inch above throat plate.

To set feed dog at correct height, loosen the two hex-head screws shown in Fig. 60.

To obtain a height of 3/64 inch above throat plate, turn hinge pin eccentric, Fig. 59, until flat on slotted end is at top as shown.

To obtain a height of 1/32 inch above throat plate, turn hinge pin eccentric until flat is at bottom.

To raise or lower REAR END of feed dog, turn hinge pin eccentric out of its set position, as required.

If desired height cannot be obtained as previously stated, loosen clamp screw on crank shown in Fig. 60. Raise or lower feed bar as required to obtain desired height. Securely tighten clamp screw.

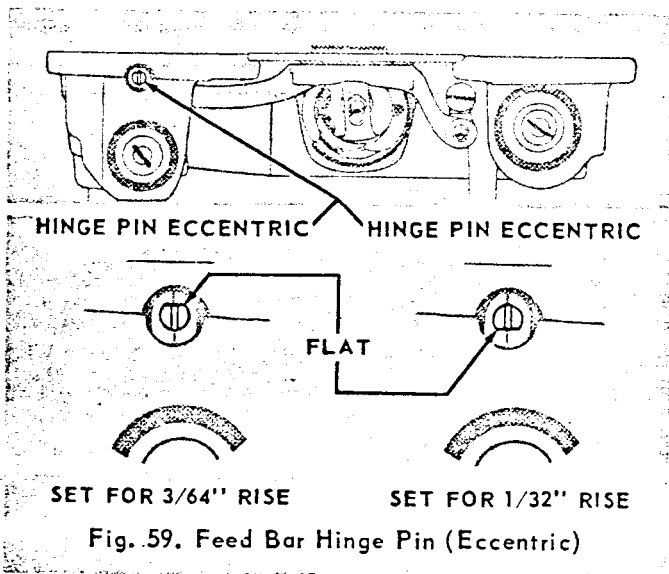

SETTING THE FEED DOG HEIGHT (Continued)

Level the feed dog by means of hinge pin eccentric as previously instructed. Securely tighten the two hex-head screws shown in Fig. 60.

NOTE: Variations in feed dog height may sometimes be necessary to balance height in relation to presser foot pressure.

AVAILABLE FEED ECCENTRIC STOP SCREWS

Machine is prevented from making longer stitches than a predetermined maximum by a stop screw shown in Fig. 61, in the feed eccentric.

The following stop screws are available for these machines:

- 5½ stitches per inch, stop screw 140257
- 7 stitches per inch, stop screw 140256
- 8 stitches per inch, stop screw 140568
- 10 stitches per inch, stop screw 141151
- 14 stitches per inch, stop screw 140258

Stitch length setting should NEVER EXCEED capacity of fittings in use.

SETTING THE PRESSER BAR HEIGHT

When presser foot rests firmly on throat plate, with feed dog below throat plate, there should be a slight clearance between guide and lifting bracket, shown in Fig. 62.

When presser foot is raised to highest point and needle bar is at bottom of its stroke, top of presser foot should not contact needle bar.

To adjust for clearance between guide bracket and lifting bracket, remove large plug from face plate and loosen clamp screw thus made accessible.

This clamp screw is shown in Fig. 62. Face plate is removed in this illustration only to show entire presser bar assembly.

Raise or lower guide bracket as required.

Make certain that presser bar is correctly turned, with needle centered in needle slot (or between the toes) of presser foot, then securely tighten clamp screw.

CAUTION: Whenever guide bracket has been moved on presser bar, inspect the check spring for correct setting as previously instructed.

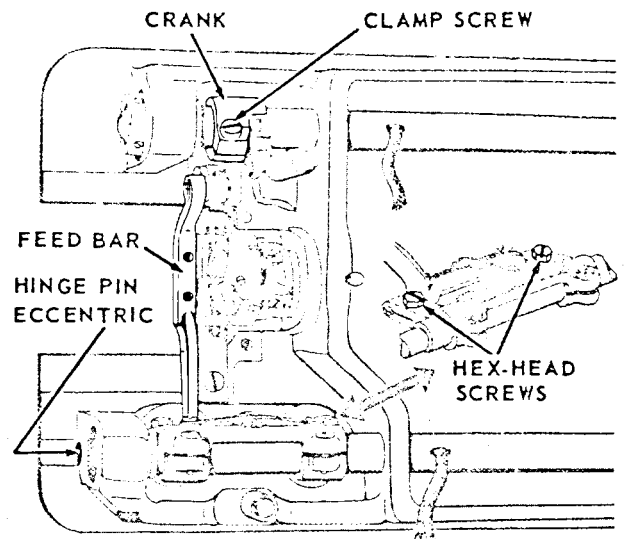

Fig. 60. Feed Bar and Crank

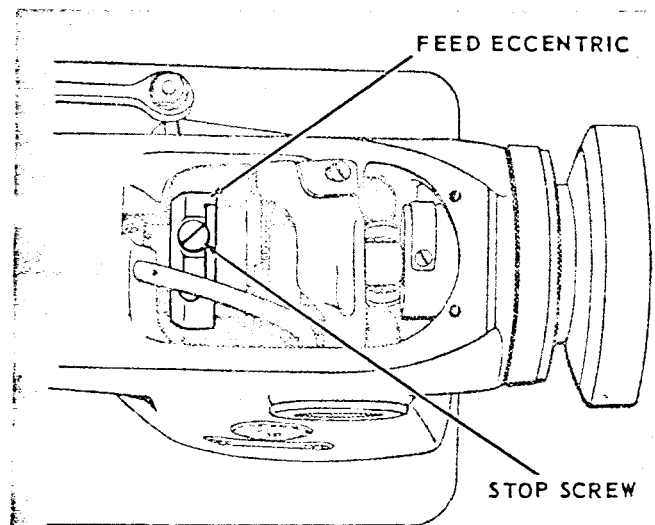

Fig. 61. Feed Eccentric Stop Screw

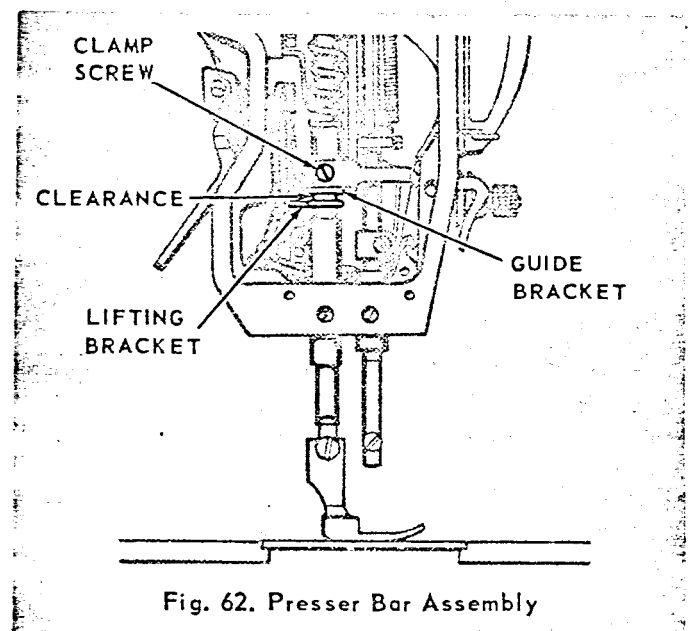

Fig. 62. Presser Bar Assembly

ADJUSTING NEEDLE THREAD TENSION RELEASER

(MACHINES ~~281-20~~ AND 281-23)

281-30

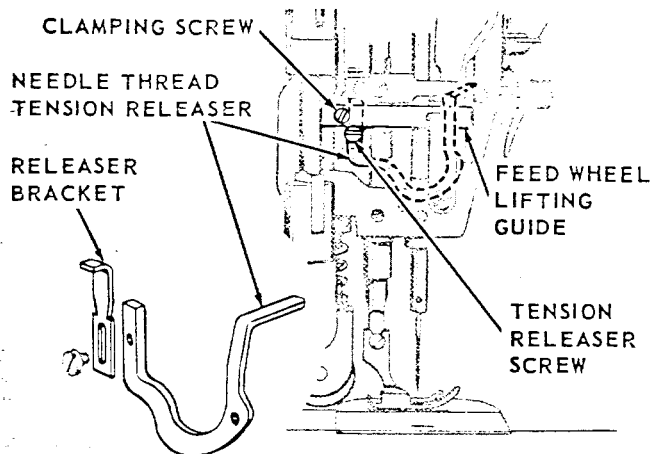

Fig. 63. Adjusting Tension Releaser on Machines ~~281-20~~ and 281-24

281-30

Needle thread tension releaser should release tension whenever presser foot is raised to its highest position.

If tension is not FULLY released when presser foot is raised or is partially released when presser foot is down: - - - Loosen clamping screw on lifting guide shown in Fig. 63, and raise guide high enough to obtain access to tension releaser screw. Loosen tension releaser screw and RAISE, releaser bracket to release tension LATER, or LOWER releaser bracket to release tension SOONER. Securely tighten tension releaser screw.

Make certain that feed wheel is aligned with feed dog as shown in Fig. 64 and that there is no bind in upper feed assembly. Then, securely tighten lifting guide clamping screw.

TO CHANGE FEED WHEEL (MACHINE 281-23)

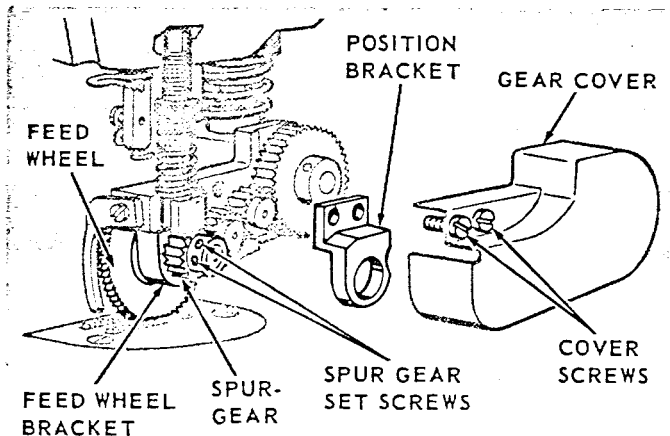

Fig. 64. Changing the Feed Wheel on Machine 281-23

Remove the two cover screws and gear cover, shown in Fig. 64.

Loosen two spur-gear set screws and remove spur-gear.

Withdraw feed wheel with its shaft from feed wheel bracket.

Place required feed wheel on bracket. Replace spur-gear, so that its screws will bear on "flats" on shaft.

Feed wheel may be moved slightly toward or away from needle to suit sewing conditions. Then securely tighten spur-gear set screws and replace position bracket and gear, fastening them to feed wheel bracket with two screws, as shown in Fig. 64.

TO CHANGE UPPER FEED ROLLER (MACHINE 281-30)

(see temporary parts list)

Remove face plate.
Remove Retaining Ring 13288 on upper Connecting Stud 149280.
Slide out upper Connecting Stud 149280.
Remove Retaining Ring 149286 on Feed Roller Shaft 149293.
Remove Feed Roller Shaft and Connecting Link 149279.
Feed Roller will drop from bracket.

Place required Feed Roller in upper Roller Bracket.

Lettering on Feed Roller Clutch must be on the operator's left side for proper feeding direction.

Install Feed Roller Shaft 149293 and Connecting Link 149279.

Replace upper Connecting Stud 149280.
Replace Retaining Ring 13288 on Stud.
Replace Retaining Ring 149286 on Feed Roller Shaft.

Replace Face Plate.

Check setting of upper Feed Roller at correct height (see Page 25).

Adjust if necessary.

SETTING FEED ROLLER AT CORRECT HEIGHT
(MACHINE 281-20)

281-30

(See temporary parts list.)

When presser foot rests firmly upon the throat plate, the upper feed roller should clear the lower feed roller .003" to .005" (equal to about the thickness of one sheet of newspaper).

The upper feed roller bracket, 149290, is held up by a lip on the upper feed roll bracket guide, 149274.

To adjust height, loosen two (2) screws, 140306, lift upper feed roller bracket, 149290, with lip of feed roller guide, 149274, until piece of paper slides between roller. Securely tighten two (2) screws, 140306. Check clearance by rotating rollers; readjust if necessary.

*The timing screw for the 281-30 is the screw closest to the flat on eccentric body.

TO SYNCHRONIZE THE FEED
(MACHINES 281-6, 281-20 AND 281-23)

281-30

Top-feed must be synchronized with bottom-feed so that both move from front to rear simultaneously, feeding the material smoothly and firmly.

BOTTOM-FEED: Before machine leaves factory, feed-lifting-eccentric-and-bevel-gear and feed-eccentric are timed for average sewing conditions; having timing screw in each eccentric enter groove provided for it in arm shaft.

TOP-FEED (See Fig. 67): To synchronize top-feed with bottom feed motion, remove arm top cover, as shown in Fig. 67, and loosen the TIMING SCREW and the other two screws in the top feed eccentric.

Reset eccentric by rotating it slightly TOWARD operator to start top-feed movement SOONER, or AWAY FROM operator to start top-feed movement LATER.

Tighten the three screws in the eccentric.

Replace arm top cover, fastening it with four screws.

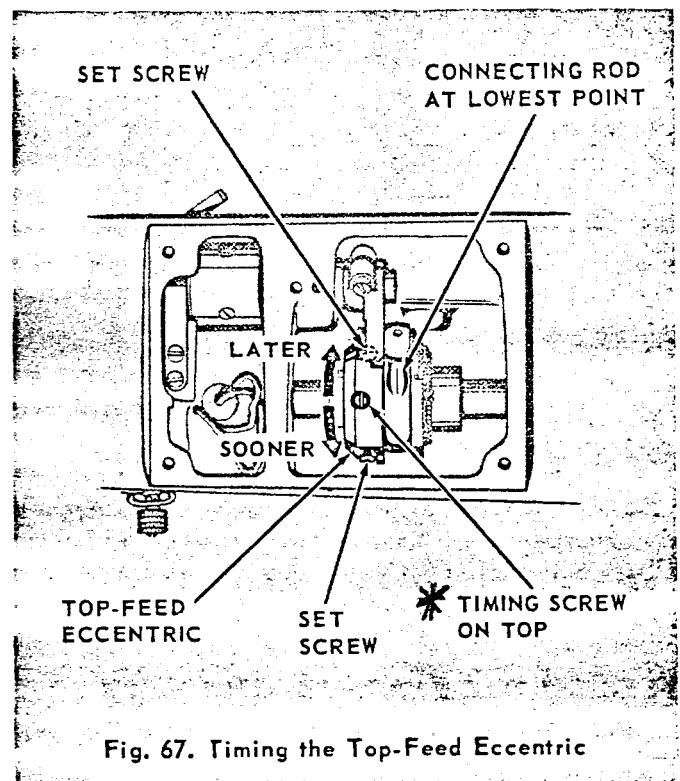

Fig. 67. Timing the Top-Feed Eccentric

TO CHANGE LOWER ROLLER
(MACHINE 281-30)

(See temporary parts list.)

Remove Position Finger as shown on Page 19.

Loosen Set Screw 350656.

Slide out lower Roller Shaft 149266.

Roller will drop from its assembly.

Place required lower feed roller into bracket. Slide in lower Roller Shaft 149266 (CAUTION: There should be at least 1/16" clearance between end of shaft and feed bar.) Line up undercut on shaft with set screw.

Securely tighten Set Screw 350656.

Replace position finger as shown on Page 19.

TO ADJUST UPPER FEED ROLLER BRAKE
(MACHINE 281-30)

The Upper Feed Roller Bracket 149290 is fitted with a one-way indexing clutch. The feed roller should index only in the direction of feed. If the roller oscillates, the pressure applied to the brake should be checked by carefully tightening Screw 233.

CAUTION: All regular single needle lockstitch fittings can be used on the 281-30 Machine. However, a clearance for the lower feed roller must be ground in all throat plates.