

SERVICE MANUAL

AND PARTS LIST

FOR

SINGER™

FOUR-THREAD

DUAL STITCH

OVEREDGING MACHINES

246k50 and 246k51

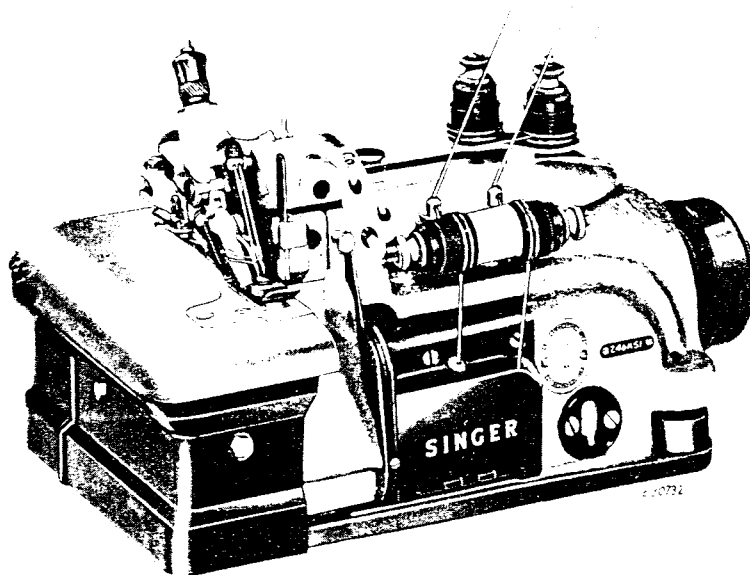

Machine 246K51

CAUTION—See that machine reservoir is filled with oil, as instructed on page 5 before using machine.

THE SINGER MANUFACTURING COMPANY

Copyright Under International Copyright Union

CONTENTS

	Page		Page
DESCRIPTION	2	PARTS COMPLETE FOR 246K50	29
SETTING UP	4	PARTS SPECIAL TO 246K51	39
LUBRICATION	5	FITTINGS	40
INFORMATION FOR OPERATOR.....	5-10	ACCESSORIES	46
ADJUSTMENTS	11-23	NUMERICAL LIST OF PARTS	49
PARTS LIST	25		

INDEX

	Page		Page
Accessories to Machines	4	Needle Clamp, Setting	14
Bight Adjustment	21, 22	Needle Curvature Gauge 164588	6
Cleaning	5, 12	Needle Guard	22
Clearance between Loper Carrier Connection and Guide Bar Bracket	16	Needles	6, 7
Contact Point of Knives	20	Needle Setting	7
Curvature of Needle Blade	6	Needles and Thread	6
Description of Oil	Inside Front Cover	Needle Thread Controller, Setting	18
Differential Feed	12	Preparation for Threading	7
Feed Controls	12	Pressure of Presser Foot	10
Feed Dogs, Setting	13	Right Loper, Installing	17
Feed Dogs, Tilting	13	Right Loper, Setting	16, 17
Feed Eccentric Extractor 164203	11	Running-in Machine	5
Feed Eccentrics, Changing	11	Sharpening Knives	23
Feed Eccentrics, Sizes Recommended	11	Speed	6
Foot Lifter	4	Stationary Knife	20-23
Formation of Stitch	3, 8	Stitch Formation	3, 8
Four-Thread Dual Stitch	3, 8-10	Stitch Length, Regulating	11
Gathering	12	Stretching	12
Gauge 164883	13-17	Stripper	19
Knife Grinder 701-9	23	Suggestions for Efficient Operation	12
Knife Sharpening	23	Take-up Adjustments	19
Knives, Removal and Replacement	20	Threading	8-10
Left Loper, Setting	15	Threading Wire 164196	4, 9
Length of Stitch	11	Thread Tensions, Regulating	10
Looper Thread Eyelet, Setting	19	Tools	4
Looper Thread Stripper	19	Trimmer, Adjustments	21, 22
Looper Thread Take-up Adjustments	19	Unwinder	4, 10
Machine Pulley	3, 4, 12	Width of Bight	21, 22
Movable Knife	20-23	X-Ray View of Machine	3

DESCRIPTION

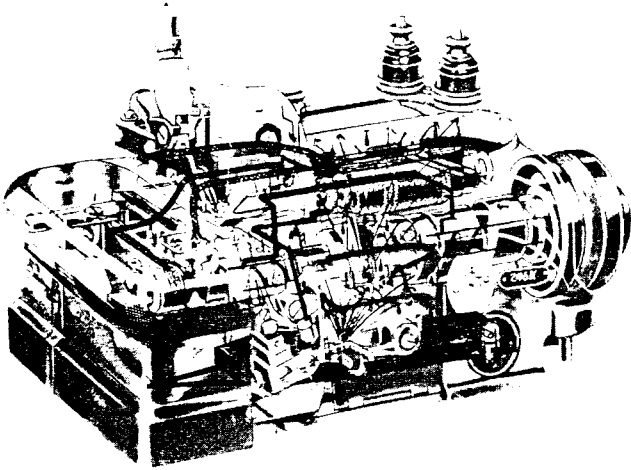

Fig. 2. X-ray View of Class 246K Machine
(Lubricating System Shown in Solid Black)

Machines 246K50 and 246K51 produce high speed reinforced overedging and simultaneous trimming on sweaters, sport clothes, bathing suits, house dresses, foundation garments and similar articles.

Available for continuous gathering and cuffing, intermittent gathering, ruffling, seaming, stretching, inserting, ornamental edging and welting, these powerful but compact machines produce **Stitch Type #507**. (See page 8 for description and illustration of this stitch.)

GENERAL CHARACTERISTICS

Curved needles:

Catalogue #1265 (151 × 7) when
needle gauge is .109 inch

Catalogue #1266 (151 × 9) when
needle gauge is 1/16 inch

Two needles, two loopers.

Loopers independently driven, permitting variations in their adjustment in relation to each other and to the needle, to suit the work required.

Differential feed permits gathering, stretching or uniform feed, as desired.

Either left or right twist thread may be used in needles and in loopers.

Adjustable trimmer cuts cleanly; operating in advance of needles. Trimmings guided into chip chute to avoid interference with work and with mechanism. Trimmer adjustable to cut **3/32 inch to 7/32 inch** from right hand needle.

Bight limit, 3/32 inch to 5/32 inch.

Presser foot can be swung toward left to facilitate threading or replacement of needle.

Tubular operation is accommodated by a small "horn" extension of the throat plate support.

Cloth plate can be swung to the left for convenience, when stitching tubular pieces or when making machine adjustments.

Splash lubricating system, shown in Fig. 2, automatically and continuously oils principal bearings during operation.

Oil cooling reservoir in rear of machine.

Oil level indicator gauge in direct view of operator.

Oils recommended, see inside front cover.

Machine pulley 164231 for 3/8 inch V-belt; also used for 5/16 inch round belt.

Machine pulley should always turn over away from operator when machine is in motion.

SPECIAL FEATURES

Machine 246K50

... adapted for **light and medium weight** fabrics.

... **needle gauges**. Distance between needles may be set at **.109 (7/64) inch** or at **1/16 inch**. Unless otherwise ordered, needles will be set **.109 inch** apart.

... **high looper stroke, high feed lift and high knife stroke.**

... **trimmer adjustable** to cut **3/32 inch to 1/4 inch** from right hand needle.

... **bight limit, 3/32 inch to 7/32 inch.**

... **two feed eccentrics 164915, bronze**, regularly supplied. When distance between needles is **.109 (7/64) inch**, two feed eccentrics making approximately **10 stitches to the inch** are supplied. When distance between needles is **1/16 inch** two feed eccentrics making approximately **14 stitches to the inch** are supplied. (See page 11.)

... **maximum speed, 5500 stitches to the minute.**

Machine 246K51

Similar to Machine 246K50, except—

... adapted for **medium and medium-heavy-weight** fabrics.

... **straight movable knife.**

... **needle gauge**: Distance between needles is **fixed at .109 inch.**

... **more looper stroke and higher knife stroke.**

... **trimmer adjustable** to cut **3/32 inch to 9/32 inch** from right hand needle.

... **bight limit, 3/32 inch to 9/32 inch.**

... **two feed eccentrics 164915, bronze**, making **10 stitches to the inch**, are regularly supplied (see page 11).

... **maximum speed, 5500 stitches to the minute.**

INSTALLATION

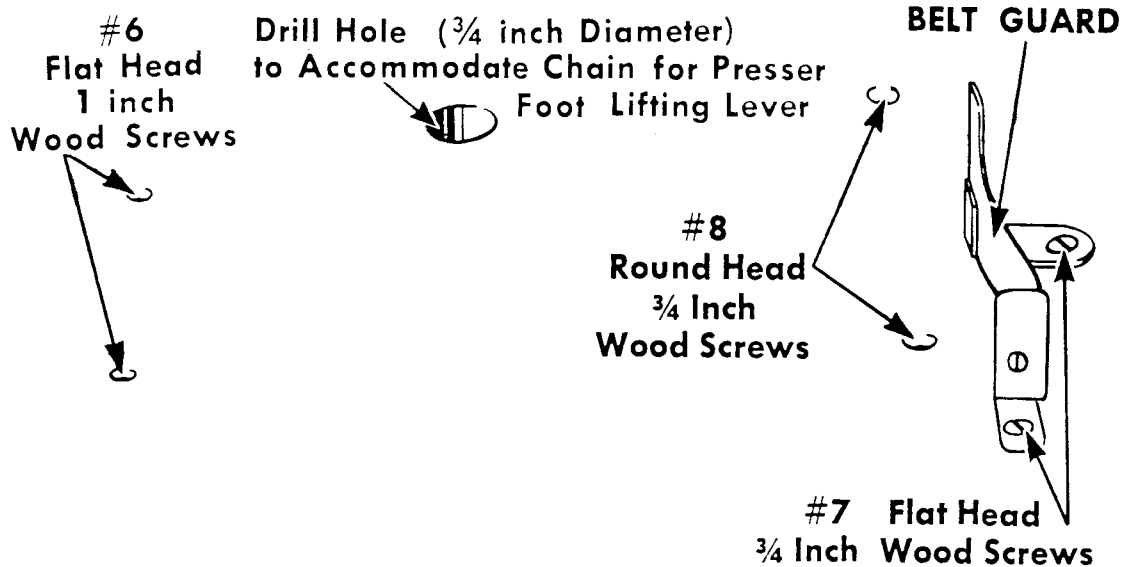

Fig. 3. Machine Base on Table, Showing Position and Drill Sizes of Holes Required for Installation

INSTALLATION OF MACHINE AND BASE ON TABLE

Place machine and base on table top with belt groove of machine pulley in line with belt groove of driving pulley.

Spot position of hole behind machine base, directly below chain slot on presser foot lifting lever.

Remove machine from base. Draw outline of machine base in position on top of table.

Drill hole spotted earlier, 3/4 inch in diameter, to accommodate chain.

Using base and belt guard as template, spot and drill six holes in table for wood screws, as shown in **Fig. 3**.

Fasten machine base and belt guard to table with the six wood screws, described in **Fig. 3**.

Set machine on rubber cushions at four corners of base.

FOOT LIFTER:

As the stand recommended for **Class 246K Machines** with foot lifter includes a suitable foot lifter treadle, foot lifter chain **6439**, without the treadle, will be sent with the machine. If, however, the machine is fitted to a stand or other equipment which does not have a suitable treadle, orders should state that foot lifter treadle **4885** is required and it will also be supplied, without extra charge.

ACCESSORIES AND TOOLS

Foot lifter. Knee lifter supplied instead, when specified on order.

Threading wire 164196.

Tweezers 164204.

Socket wrench 164197 (for needle clamping nut).

Flat, open-end wrench 8908 (for feed eccentric nut)

Screwdriver 85318.

Wrench 164831 (for right looper carrier guide bar oil plug screw nut).

Thread unwinder 151163.

CAUTION:

All of the oil is drained from the machine before it is shipped from the factory.

DO NOT START THE MACHINE UNTIL IT HAS BEEN THOROUGHLY LUBRICATED AS INSTRUCTED ON PAGE 5.

LUBRICATION

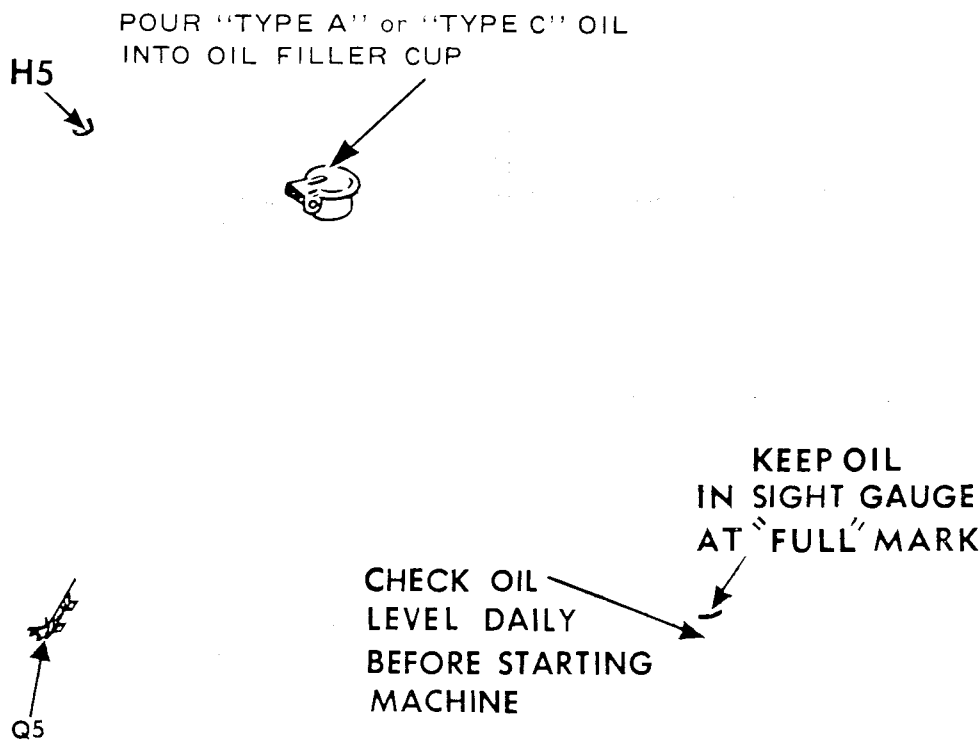

Fig. 4. Filling Oil Reservoir

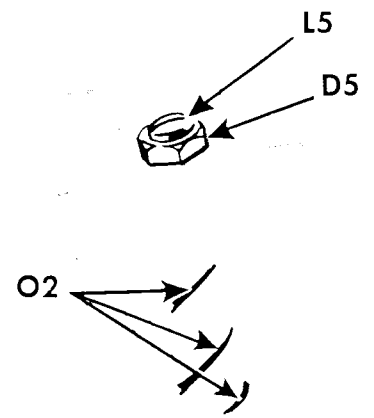

Fig. 5. Oil Flow Adjustment

Use "TYPE A" or "TYPE C" OIL, sold by Singer Sewing Machine Company.

Apply this oil to oil filler cup on top of machine, pouring oil into reservoir until oil in the sight gauge is at "FULL" mark, as indicated in Fig. 4.

Check oil sight gauge daily before starting machine and oil machine, when necessary, as instructed in Fig. 4 above.

WHEN A MACHINE HAS BEEN IDLE FOR A CONSIDERABLE TIME (OR AFTER A MAJOR INSTALLATION OF PARTS): Clean machine thoroughly. Then apply a few drops of oil to oil grooves of feed bar connections Q5 (see inset at bottom left of Fig. 4) and to looper carrier connection guide bar at O2, Fig. 5 behind upper knife carrier and chip guard. Apply a drop of oil to presser bar at H5, Fig. 4. Check oil level in reservoir, as instructed in Fig. 4.

AFTER MACHINE IS INSTALLED AND BEFORE STARTING MACHINE:

Remove the chip guard from the front of the machine.

Check the oil flow on right hand looper carrier connection guide bar at O2, Fig. 5.

To adjust amount of oil flow on guide bar at O2, loosen lock nut D5 and turn adjusting screw L5, Fig. 5 clockwise as far as possible. Oil flow is now shut off, completely.

Back off screw L5 (turning screw anti-clockwise) 1/2 turn. Check lubrication again.

To increase oil flow, turn screw L5 anti-clockwise a small amount and recheck lubrication.

If oil flow is too great, turn screw L5 clockwise about 1/4 turn and recheck.

Never operate machine when oil flow is SHUT OFF at L5.

When correct oil flow is obtained, lock the nut D5, Fig. 5. Replace the chip guard.

Remove belt and check freeness of machine by turning machine pulley by hand. Replace belt.

Finally, "run-in" the machine for approximately 15 minutes at a moderate speed.

SPEED

Maximum speed recommended for these machines is **5500 stitches to the minute**. **5000 stitches to the minute** is recommended for **long runs** or while sewing **long stitches**.

Maximum **efficient** speed is dependent upon the nature of the operation, the ability of the operator and the type of material being sewn.

It is advisable to operate these machines at more moderate speeds the first few days, after which they can be run at top speed.

When the machine is in operation, top of **machine pulley** must **always turn over away from operator**.

NEEDLES AND THREAD

Needles are of curved blade.

When distance between needles is .109 (approximately $7/64$) inch, use needles of Catalogue #1265 (151 × 7) in Sizes 9 to 12, 14, 16, 18, 19 and 21.

When distance between needles is $1/16$ inch, use needles of Catalogue #1266 (151 × 9) in Sizes 9, 11, 12, 14, 16, 18, 19, 21 and 22.

Selection of needles can make a great difference in the ease and quality of the work. It is important that each needle be just right for machine, thread and work being done.

Choose your needle carefully. The correct size will permit thread to pass freely through needle eye; avoiding strain and breakage of thread.

Either right twist or left twist thread may be used.

If trouble occurs during sewing:

Inspect needle point. A hook or burr may cause poor stitching or some materials may be cut when short stitches are used.

Check curvature of each needle, as instructed below. Unless needle has the correct curvature, it may cause skipping of stitches.

Orders for needles must specify the quantity required, the Size number and the Catalogue number.

For example

"100 Size 9, Catalogue #1265 (151 × 7) Needles."

The best stitching results will be obtained when using needles sold by Singer Sewing Machine Company.

CURVATURE OF NEEDLE BLADE

(Gauge 164588 for Needles of Sizes 9 to 16 only)

Before making any stitching adjustments, the curvature of each needle blade should be checked in the following manner:

Using gauge **164588**, shown in **Fig. 6**, insert shank of needle, with its **flat side up**, in the groove **A**. Push the needle along the groove as far as it will go against stop **B**. Tighten clamping screw **C**.

Swing the indicator **D**, slowly to and fro, along the curve of the needle blade, observing the distance between the needle blade and the tip of the indicator.

The tip of the indicator should just make contact at the needle eye and should clear needle blade, at upper end of curve, by approximately .005 to .006 inch. Use feeler gauge.

Reject any needle that cannot pass this test.

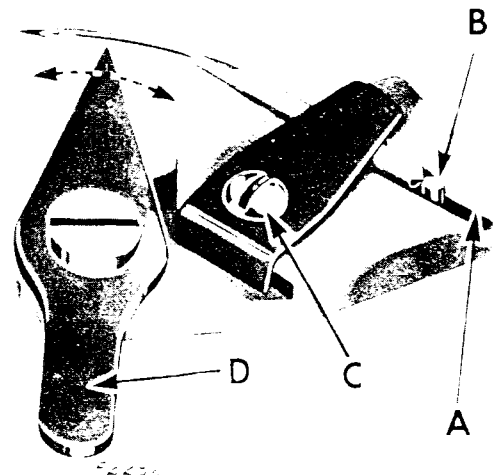

Fig. 6. Checking Needle Curvature

SETTING THE NEEDLES

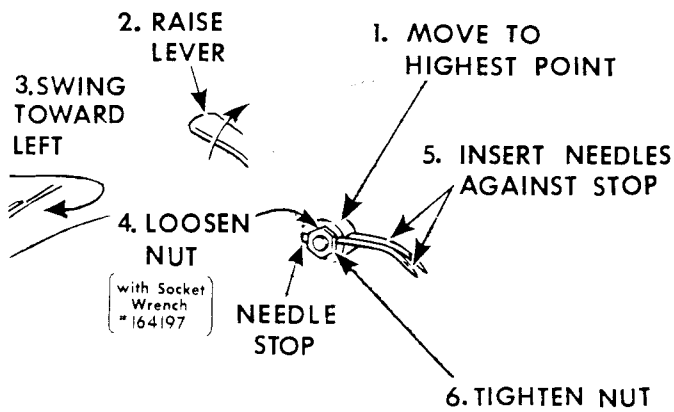

Fig. 7. Needle Correctly Set in Needle Clamp

Move needle clamp up to its **highest** position. Insert needles as instructed in **Steps 1 to 5** in Fig. 7.

When needles are correctly inserted in needle clamp, securely tighten needle clamping nut. (See **Step 6, Fig. 7.**)

PREPARATION FOR THREADING

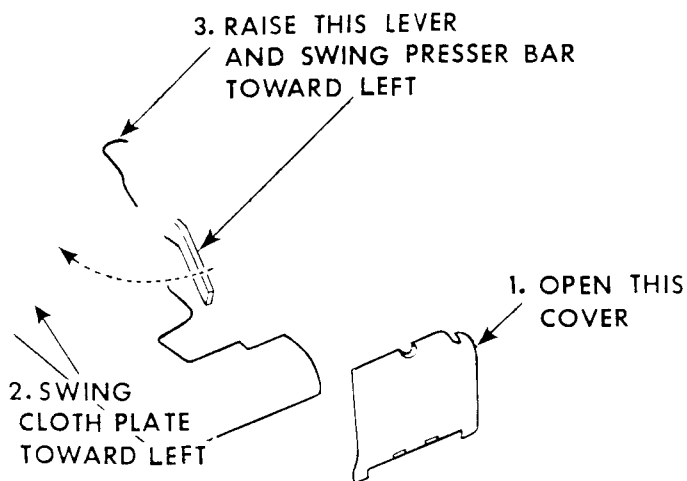

Fig. 8. Preparation for Threading

For convenience in threading . . .

- . . . On machines installed with bench stand, raise bench stand flap.
- . . . Open front cover plate, as instructed in **Step 1, Fig. 8.**
- . . . Swing cloth plate toward left. (See **Step 2.**)
- . . . Release presser bar as instructed in **Step 3,** and swing presser bar toward left.

STITCH FORMATION

The **four-thread dual chain stitch (Stitch Type #507)** is shown in **Fig. 9**. An exceptionally strong overedge stitch and a single line of reinforced stitching run parallel and close to one another on the upper side of the material. The overedge stitch is formed with thread from the right needle and two looper threads. Threads carried by left looper and left needle form the reinforcing stitch which is interwoven with the overedge stitch on the underside of the fabric. See **pages 9 and 10** for instructions on threading the machine for this stitch.

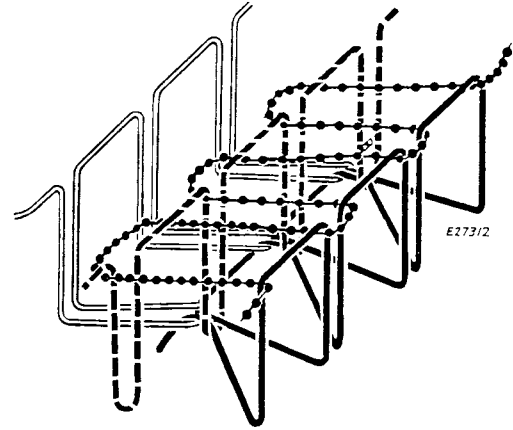

Fig. 9. Stitch Formation (Stitch Type #507)

TO THREAD UNWINDER

IMPORTANT

Thread the **right needle thread (dash line)** completely, **first**. (See **Figs. 10 to 14**.)

Thread the **left needle thread (double line)** completely, **second**. (See **Figs. 10 to 14**.)

Thread the **right looper thread (dotted line)** completely, **next**. (See **Figs. 10, 11, 15 and 16**.)

Thread the **left looper thread (Solid line)** completely, **last**. (See **Figs. 10, 11 and 16**.)

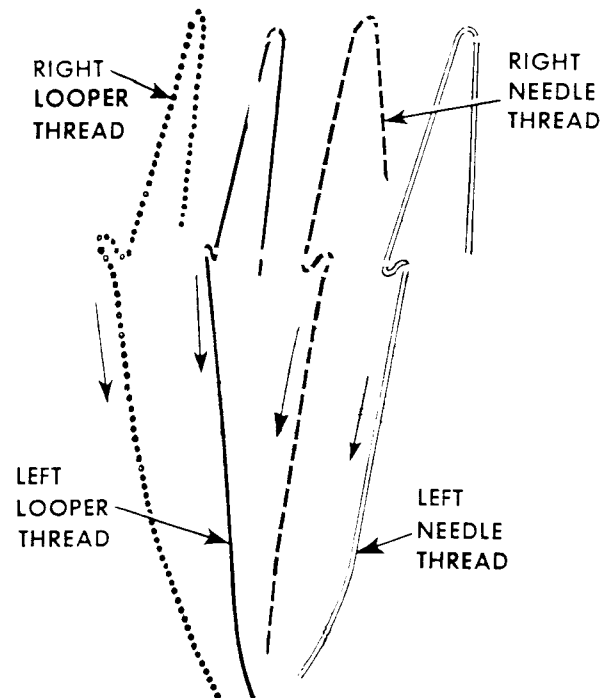

Fig. 10. Unwinder 151163 Threaded for Four-Thread Dual Stitch

TO THREAD THE MACHINE

For Four-Thread Dual Stitch
(Stitch Type #507)

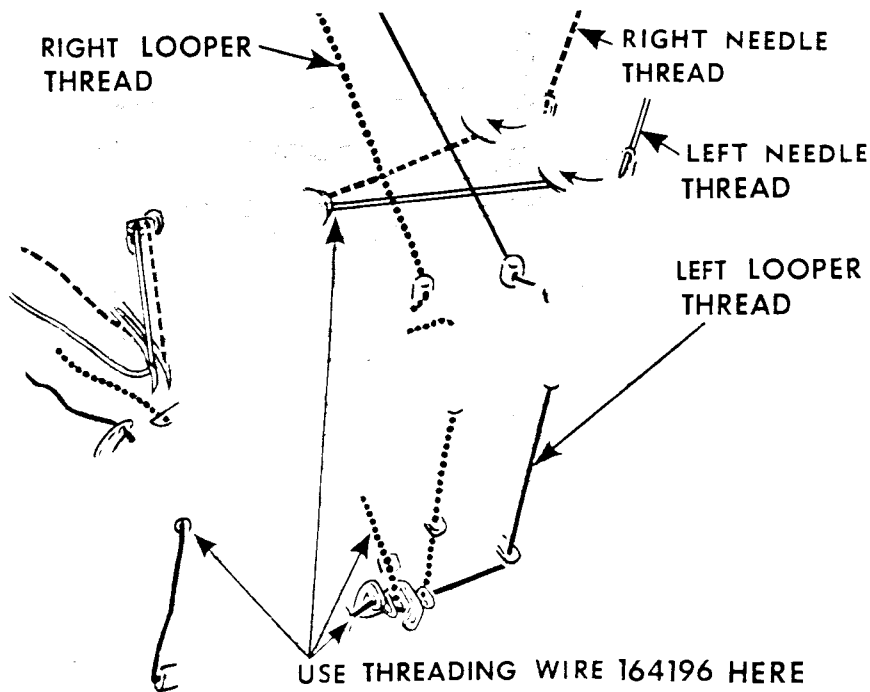

Fig. 11. Threading the Machine
(Four-thread Dual Stitch)

Fig. 12. Threading Wire 164196

Pass each thread through threading points, as shown in **Figs. 11, 12, 14 and 16.**

Use threading wire **164196**, shown in **Fig. 12**, to pass threads through threading tubes, at points indicated in **Figs. 11, 14 and 16.** Draw four or more inches of thread through eyelet in threading wire and pass threading wire through required threading tube.

THREADING NEEDLE THREADS:

Before passing needle threads through threading tubes, turn machine pulley over away from



Fig. 13. Threading Needle Thread Eyelet (Dual)

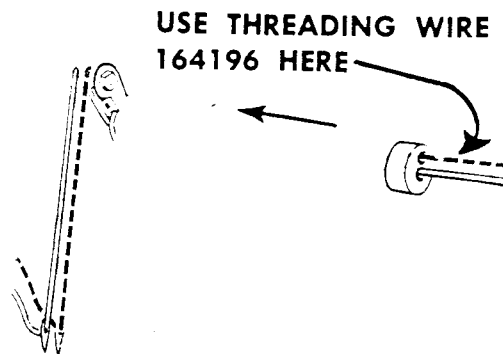

Fig. 14. Threading the Needles

operator until needles are at their **lowest position.**

The **needle thread eyelet** must be positioned and threaded as shown in **Figs. 11 and 14.**

After threading **needle thread eyelet**, raise needles to **highest** position and pass each needle thread from **front to rear** through the eye of its respective needle. When threading each needle, double back the end of the thread and twist it; making thread stiff enough to thread the needle eye easily.

TO THREAD THE MACHINE (continued)

LOOPER THREADS:

Before threading left looper, turn machine pulley over from you until eye of left looper is directly in line with threading tube underneath throat plate.

When threading right looper (see Fig. 15) be sure that there is no loose loop of thread on end of looper to cause thread breakage.

Pass each looper thread through its threading points, as shown in Figs. 12 and 16.

Draw about two inches of each needle thread through its needle eye and draw two inches of each looper thread through its looper eye, with which to start sewing.

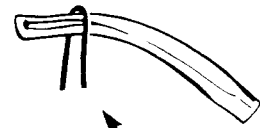

Remove this Thread Before Threading

Fig. 15. Right Looper

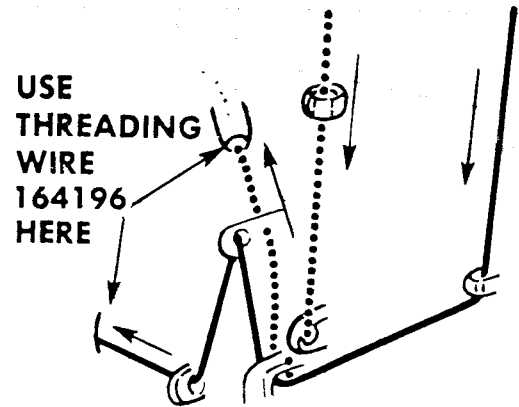

Fig. 16. Threading Looper Take-up

REGULATION

THREAD TENSIONS

Tension on needle threads should be just sufficient to set stitch correctly. (See Fig. 9, page 8 for correct stitch formation.)

For average sewing, tension on looper threads should be very light.

Regulate thread tensions as instructed in Fig. 17.

PRESSURE OF PRESSER FOOT ON MATERIAL

Correct pressure of presser foot helps feed the work properly.

Always use lightest pressure possible.

Regulate the pressure of the presser foot on the material as instructed in Fig. 17.

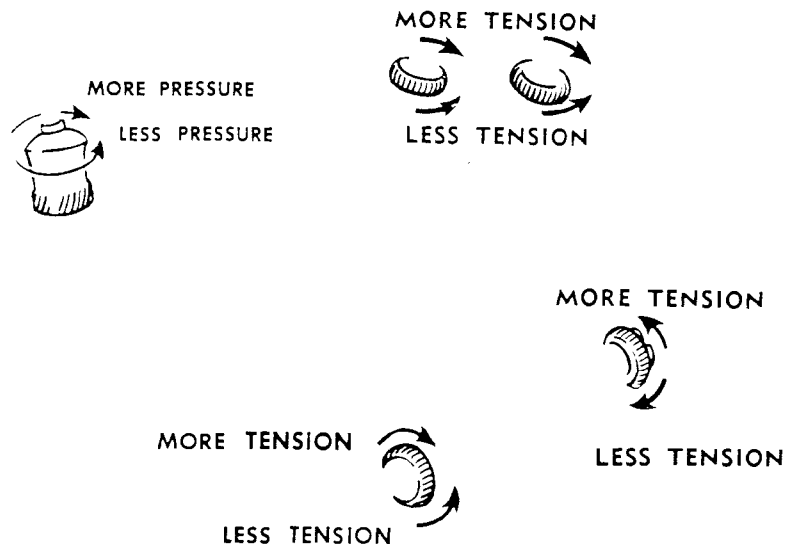

Fig. 17. Regulating Tension of Threads and Pressure of Presser Foot on Material

TO CONTROL LENGTH OF STITCH



Fig. 18. Feed Eccentric Extractor 164203 and Eccentric 164915, bronze

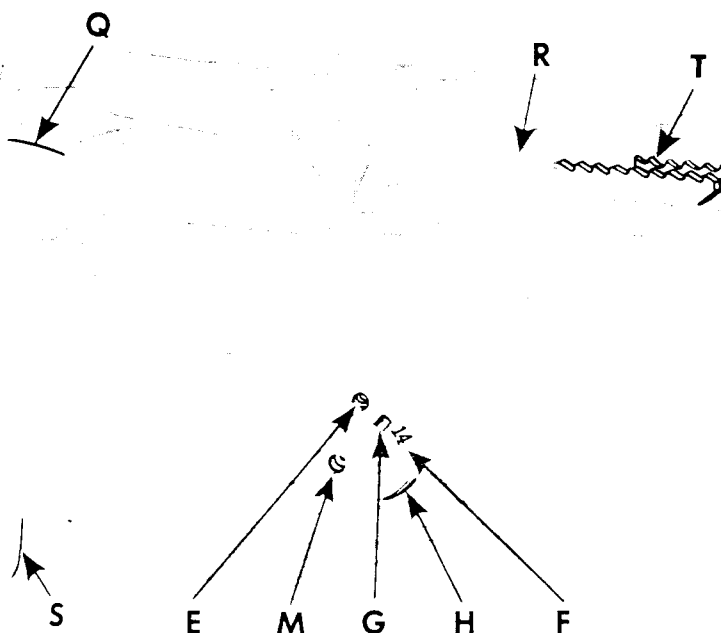

Fig. 19. Changing Length of Stitch

FEED ECCENTRIC CHART:

MACHINE	ECCENTRICS REGULARLY SUPPLIED		Type of Feed
	Quantity	Stitches to the inch	
246K50 and 246K51 with distance between needles fixed at .109 inch	two	10	Differential
246K50 only with distance between needles fixed at 1/16 inch	two	14	Differential

The length of stitch is determined by the feed eccentrics in use.

Each feed eccentric is marked with the number of stitches it makes, as shown at F, Figs. 18 and 19.

Feed Eccentric 164915, bronze, can be supplied to make 4 to 16, 18, 20, 22, 24, 28, 32, 36, 40, 45, 50, 60, 70, 80 and 100 stitches to the inch.

Unless otherwise ordered, feed eccentrics will be supplied according to chart shown above.

REMOVING FEED ECCENTRICS:

Swing cloth plate Q, presser bar and feed eccentric cover S, Fig. 19 out to the left.

Using Wrench 8908, remove the hexagon-head nut and washer from the shaft M, Fig. 19.

Screw feed eccentric extractor J, Fig. 18 into threaded hole E of outer eccentric. Pull gently with extractor J to remove outer eccentric. Inner eccentric can then be removed, in the same manner.

INSTALLING FEED ECCENTRICS:

When replacing each feed eccentric, be sure that the stamped number is on outside face of eccentric, as shown at F, in Fig. 19.

The keyway on the eccentric should fit over key at G on shaft M. Line up front and rear feed bars and install eccentrics. When both feed eccentrics are in position, replace washer and hexagon head nut and screw hexagon head nut securely on the shaft M.

FEED CONTROLS

THE DIFFERENTIAL FEED consists of **two** feed dogs **R** and **T**, Fig. 20, independently actuated by **two** feed eccentrics at **F**, Fig. 20. The **inner** feed eccentric (which is placed on the shaft **first**) controls the movement of the **front** feed dog **T**. The **outer** feed eccentric at **F** (which is placed on the shaft **last**) controls the movement of the **rear** feed dog **R**.

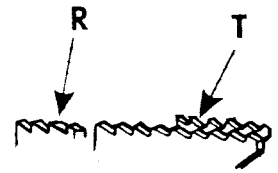

To feed the work evenly use two feed eccentrics marked for the same stitch length.

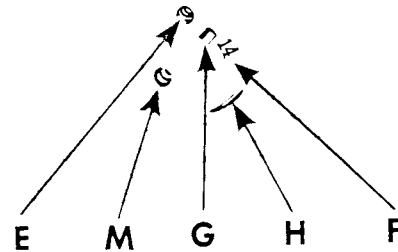

Fig. 20. Differential Feed

To gather . . . for front feed dog use feed eccentric that is marked for **longer** stitch length than that used for rear feed dog. Place eccentric marked for **longer** stitch length on shaft **first**.

To stretch the material while sewing . . . for front feed dog use feed eccentric that is marked for a **shorter** stitch length than that used for rear feed dog. Place eccentric marked for **shorter** stitch length on shaft **first**.

SUGGESTIONS FOR EFFICIENT OPERATION

Always turn machine pulley over away from you.

Never allow oil level in oil reservoir to drop below the "FULL" mark on the oil sight gauge.

Clean out any lint around the loopers and between the feed rows of the feed dog.

Frequently inspect area beneath presser bar housing and behind upper knife lever cover and remove accumulation of lint.

Always use lightest tensions and lightest pressure possible on material.

Don't forget to remove loop of thread from right looper before threading.

NOTE: The instructions on the following pages are for Service Representatives.

To insure proper timing and avoid unnecessary repetition, these instructions should be followed in the order given.

TO SET THE FEED DOGS AT THE CORRECT HEIGHT

Using Gauge 164883
(See Fig. 21)

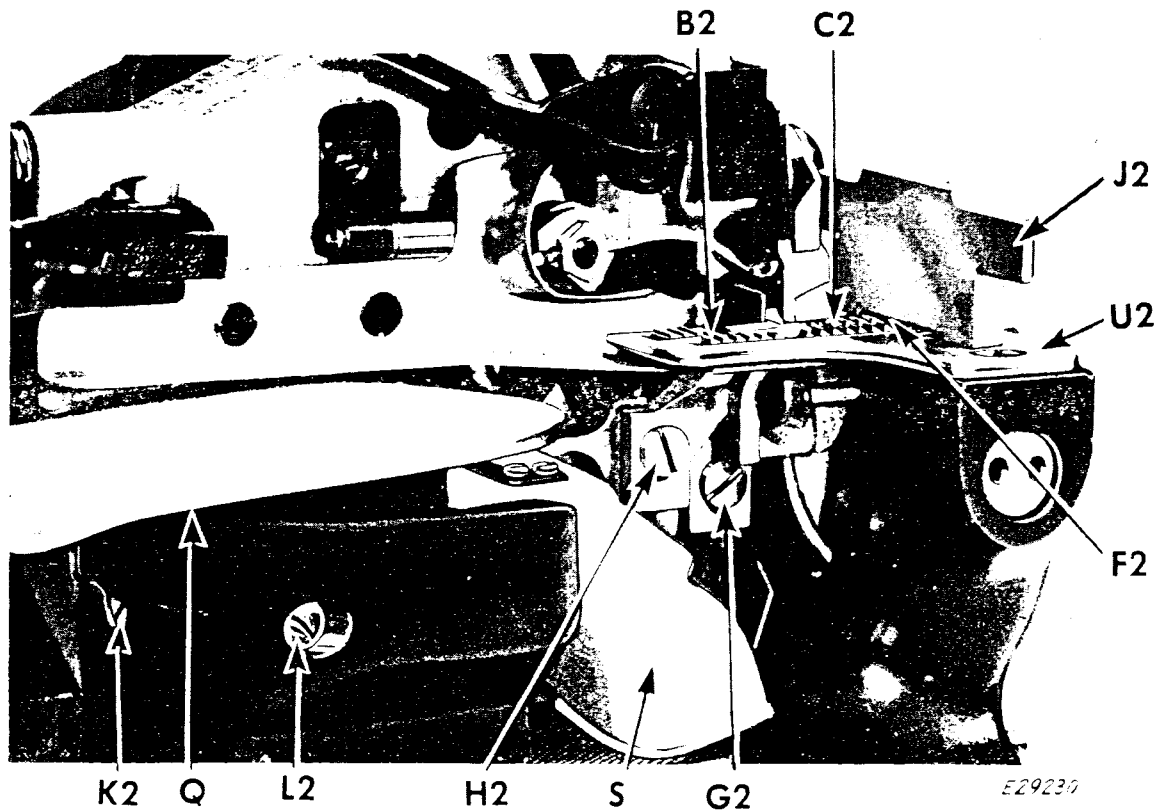

Fig. 21. Setting the Feed Dog

CHECKING HEIGHT OF FEED DOGS:

Swing the presser foot out to the left, and turn the machine pulley over from you until the feed dogs are at their highest position.

Place the gauge **J2**, over the front feed dog, as shown in **Fig. 21**. Gauge **J2** must rest firmly upon the throat plate **U2**. At this setting, front feed dog should just touch the bottom face **F2** of the gauge.

Set rear feed dog at same height as front feed dog.

ADJUSTMENT:

Swing the cloth plate **Q** and the feed eccentric cover **S** out to the left.

Loosen the adjusting screw **G2** and raise or lower the front feed dog **C2**, as required. Then tighten screw **G2**.

Loosen the adjusting screw **H2** and raise or lower the rear feed dog **B2**, as required. Then tighten screw **H2**.

TO TILT THE FEED

See Fig. 21

When it is desired to tilt the feed, first set it at the correct height as described above.

Loosen the hinge pin set screw **K2**, **Fig. 21** at the rear of the machine **just 1/2 turn**.

To tilt the feed **up in the rear** and **down in the front** of the needle, slowly turn the hinge pin **L2** **over toward the rear** of the machine, until the desired amount of tilt is obtained.

To tilt the feed **down in the rear** and **up in the front** of the needle, slowly turn the hinge pin **L2** **over toward the front** of the machine, until the desired amount of tilt is obtained. Then tighten the screw **K2**.

TO SET THE NEEDLE CLAMP AT THE CORRECT HEIGHT

Using Gauge 164883
(See Figs. 22 and 23)

CHECKING HEIGHT OF NEEDLE CLAMP:

Turn the machine pulley over from you until the needle clamp **R2** reaches its **highest** position.

Swing the presser foot and cloth plate out to the left.

Remove the needle and the throat plate.

Turn the machine pulley over from you until the needle clamp **R2** reaches its **lowest** position.

Slip the "LOW" end of the gauge **J2** between the needle clamp and the throat plate seat **V2**, as shown in Fig. 22.

At this setting, the needle clamp **R2** should **just touch** the top surface **Q2** on the "LOW" end of the gauge **J2**.

ALTERNATE CHECK: In the absence of a gauge, the distance between bottom of needle clamp at its lowest position and top surface of throat plate seat should be set at

.3925 inch when needle gauge is .109 inch

.406 inch when needle gauge is 1 16 inch.

ADJUSTMENT:

Remove the top frame cover and loosen the clamping screw **T2** and the two screws **P2** and **Y**, Fig. 23.

Raise or lower the needle clamp **R2** as required.

To secure the needle clamp in the correct position, first securely tighten the screw **T2**, then tighten the two screws **P2** and **Y**.

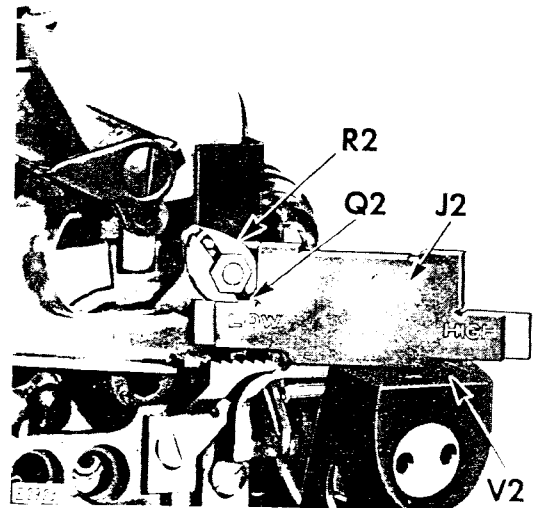

Fig. 22. Checking the Needle Clamp Height

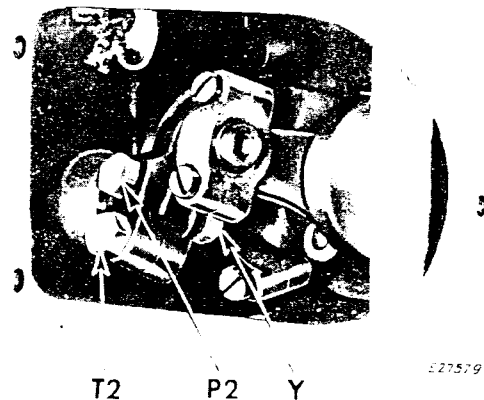

Fig. 23. Adjusting the Needle Clamp

TO SET THE LEFT LOOPER IN RELATION TO THE NEEDLES

Using Gauge 164883
(See Figs. 24 and 25)

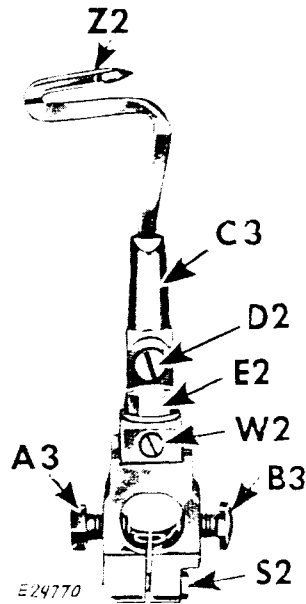

Fig. 24 Left Looper Assembly



Fig. 25. Setting

PREPARATION:

Check the needle with needle gauge 164588, as instructed on page 6.

Set the needle in the machine as instructed on page 7.

Remove throat plate and chip guard.

Loosen set screw D2, Fig. 25 in left looper holder C3.

Set left looper Z2 all the way down into its holder.

Securely tighten set screw D2.

CHECKING LEFT TO RIGHT POSITION:

Place gauge J2 on throat plate seat V2, as shown in Fig. 25.

Turn machine pulley over away from you until needle clamp R2 reaches its lowest position and then rises sufficiently to permit "HIGH" end of gauge J2 (.422 inch) to pass between needle clamp R2 and throat plate seat, as shown in Fig. 25.

When needle clamp R2 just contacts top surface U4 of gauge, the tip of left looper Z2 should be between centre and left side of right needle.

SETTING LEFT TO RIGHT POSITION:

Loosen screw S2, Fig. 24.

To move left looper Z2 toward left, loosen screw A3 and tighten B3 an equal amount, as required.

To move left looper Z2, toward right, loosen screw B3 and tighten screw A3 an equal amount, as required.

Recheck setting. When correct setting is obtained, securely tighten clamping screw S2.

CHECKING FRONT TO REAR POSITION:

Turn machine pulley so that loopers move through one complete sewing cycle. Observe looper movement.

The left looper must rub lightly on each needle as it passes behind the needles in its movement toward the right.

SETTING FRONT TO REAR POSITION:

Turn machine pulley over away from you until point of looper Z2 just reaches the right needle.

Loosen screw E2 just enough to allow movement of looper holder C3. Loosen set screw W2.

Move looper holder C3 toward rear of machine. Turn set screw W2 inward until proper relation between needles and left looper is obtained. Securely tighten screw E2.

Replace throat plate and chip guard.

TO SET THE RIGHT LOOPER IN RELATION TO THE NEEDLES

Using Gauge 164883
(See Figs. 26 and 27)

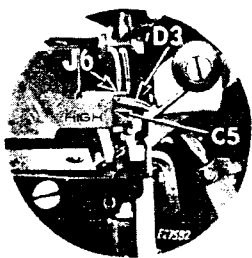

Fig. 26. Right Looper

PREPARATION:

Check the curvature of the needles with needle gauge 164588 as instructed on page 6.

Set the needles in the machine as instructed on page 7.

Swing presser foot and cloth plate to the left.

Remove chip guard and looper thread plate, complete.

CHECKING CLEARANCE BETWEEN LOOPER CARRIER CONNECTION AND GUIDE BAR BRACKET:

Turn machine pulley until right looper **D3** is at its extreme left position.

Check distance **E3** between looper carrier connection **W3** and guide bar bracket **X2**, Fig. 27 with

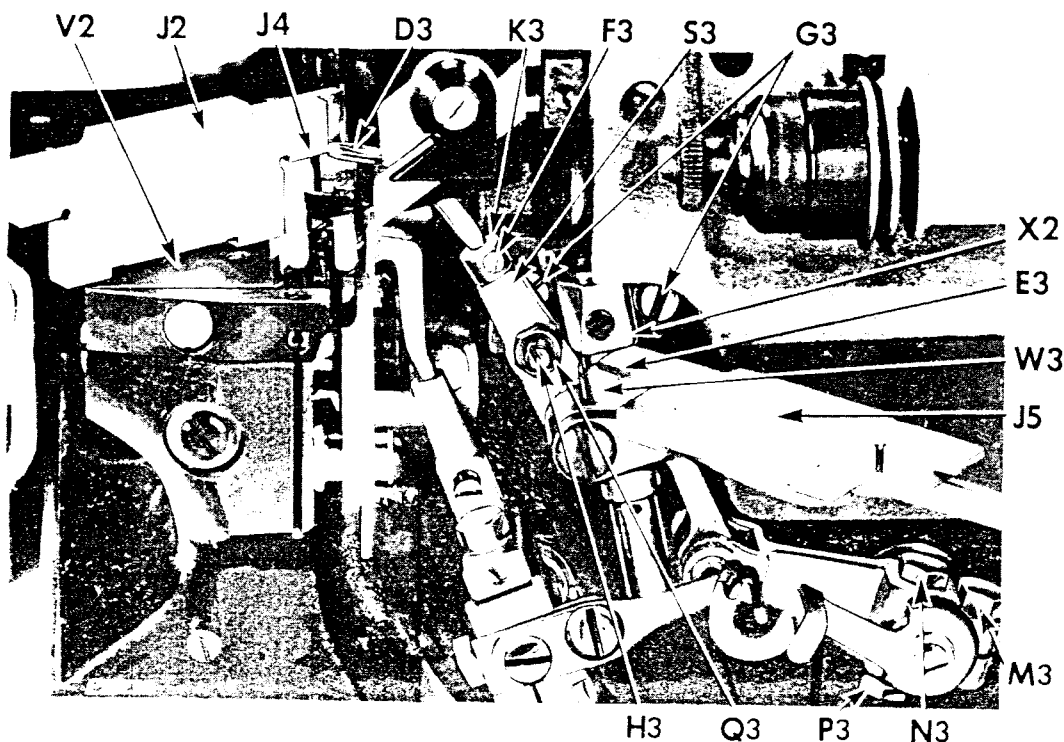

Fig. 27. Adjustments

gauge, as shown at **J5**, Fig. 27. Check this distance with "HIGH" and "LOW" ends of gauge.

CLEARANCE ADJUSTMENT:

Loosen clamping screw **M3** and screws **N3** and **P3**.

Raise or lower right hand looper carrier connection **W3**, as required.

Securely tighten clamping screw **M3**.

Tighten screws **N3** and **P3**.

TO SET THE RIGHT LOOPER (continued)

CHECKING RIGHT TO LEFT POSITION:

Hold gauge so that end marked "HIGH" on gauge **just touches** left side of right needle, as shown at **J6** in **Fig. 26**.

When right looper **D3** is at its extreme left position it should **just touch** surface **C5** on gauge, as shown in **Fig. 26**.

At this setting bracket **X2**, **Fig. 27** should be approximately at **midpoint** of its extreme left to right positions on casting.

ADJUSTMENT OF RIGHT TO LEFT POSITION:

Loosen the two screws **G3** and move bracket **X2**, as required, to bring right looper **D3** in correct contact with gauge surface **C5**.

Securely tighten two screws **G3**.

CHECKING HEIGHT:

Place gauge **J2** firmly upon throat plate seat **V2** with end marked "LOW" toward needle, as shown in **Fig. 27**.

When right looper **D3** is at its extreme left position its **highest point** should **just touch** undersurface **J4** on gauge, as shown.

ADJUSTMENT FOR HEIGHT:

When installing a right looper, loosen nut **Q3**, **Fig. 27**, and turn screw **H3** anti-clockwise to align the screwdriver slot in head of screw **H3** with centre-line of looper carrier **S3**, as shown in **Fig. 27**. Then loosen screw **F3**. Place collar **K3** on looper shank and insert right looper in looper holder **G3**, as shown in **Fig. 27**.

Adjust the height of the right looper in the following manner—

Loosen screw **F3** and nut **Q3**, **Fig. 27**.

Raise or lower right looper **D3** in carrier as required.

Press collar **K3** firmly against top of carrier **S3**.

Securely tighten screw **F3** and nut **Q3**.

CHECKING FRONT TO REAR POSITION:

Turn machine pulley over away from operator through one full revolution. Observe position of right looper in relation to needles during this full movement.

Right looper **D3** should pass behind left looper head and in front of needles; brushing lightly on needles.

ADJUSTMENT OF FRONT TO REAR POSITION:

Loosen nut **Q3**, **Fig. 27**.

Turn right looper **D3** in carrier **S3** as required.

Securely tighten nut **Q3**.

Recheck each setting and securely fasten all parts loosened earlier.

TO SET NEEDLE THREAD CONTROLLER

(See Figs. 28 and 29)

FUNCTION:

The needle thread controller **J3** should aid in the **setting of the stitch** by taking up the slack of needle threads as the needles finish their downward stroke; thus setting the stitch as the needle thread loops are shed from the loopers.

When needles are at their highest position, needle threads should run **under clearance U3** of needle thread controller **J3**, shown in **Figs. 28** or in fork **U3** of controller **J3**, shown in **Fig. 29**.

VARIATIONS: The desired setting for needle thread controller may vary with changes in thread, special fittings or materials in use.

ADJUSTMENT:

Swing presser bar **A2**, **Fig. 29** and cloth plate **Q2** out to the left.

Remove screws **X5** and oil splash guard **Z5**.

Turn machine pulley over away from operator until needle is at its **highest** position.

Loosen the two screws **V3** and move needle thread controller **J3** **toward the front to tighten the stitch** or **toward the rear to loosen the stitch**, as required. Then tighten the two screws **V3** and recheck the stitch setting.

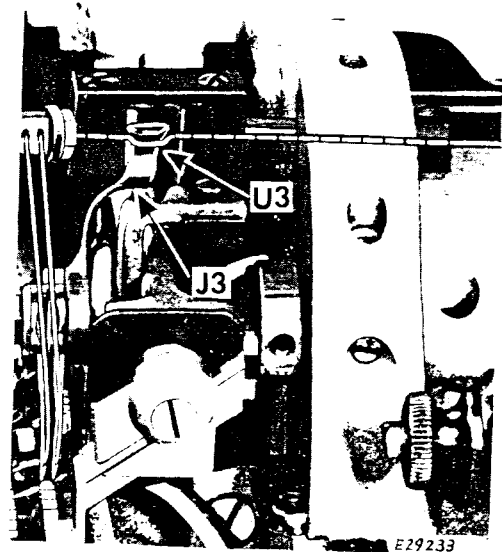

Fig. 28. Needle Thread Controller in Correct Relation to Needle Thread

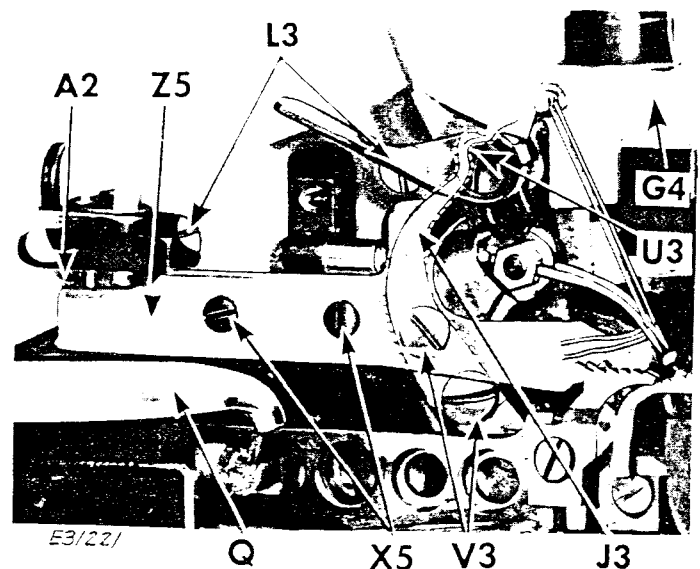

Fig. 29. Adjustments to Needle Thread Controller

Figs. 28 and **29** show the correct position of the needle threads as they pass the needle controller **J3**. To check this condition, remove two screws **L3** and presser bar housing **G4**.

After making certain that the needle threads are in the correct position, replace presser bar housing **G4** and fasten with two screws **L3**.

Replace splash guard **Z5** with two screws **X5**.

TO ADJUST THE LOOPER THREAD TAKE-UP

(See Fig. 30)

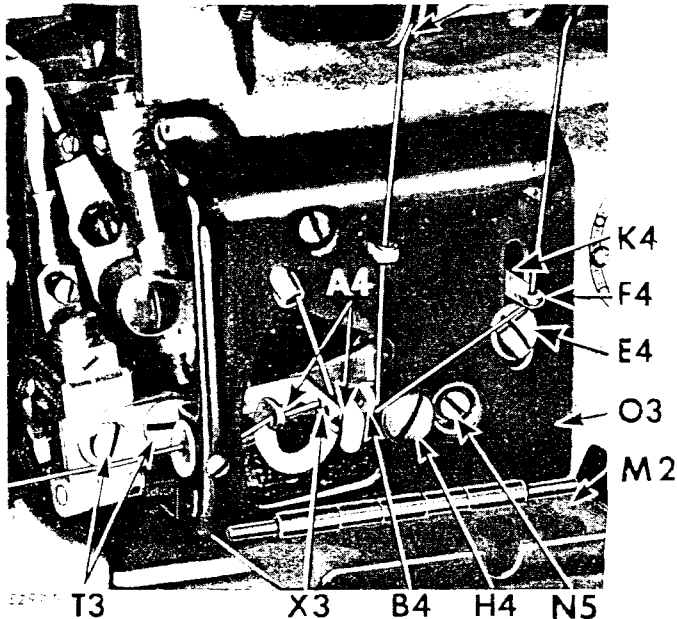

Fig. 30. Looper Thread Take-up Adjustments

ADJUSTING LOOPER THREAD TAKE-UP (LEFT) X3 FOR MORE OR LESS THREAD:

Remove the chip guard **W**, Fig. 31, page 20 and open the front cover plate **M2**. Loosen the two screws **T3**, Fig. 30 and raise or lower the right end of the left take-up **X3**, as required.

Securely tighten the screws **T3** and replace the chip guard.

SETTING LOOPER THREAD EYELET (LEFT):

The looper thread eyelet **F4** should be normally at the midpoint of the slot **K4**, as shown in Fig. 30.

To adjust the looper thread eyelet, loosen the screw **E4** and lower the eyelet **F4** to the proper location. Then securely tighten the screw **E4**.

SETTING LOOPER THREAD TAKE-UP (RIGHT):

To set the right take-up **A4**, open the front cover plate and loosen the screw **N5**, Fig. 30. Raise or lower the right take-up **A4**, as required. **Do not permit** take-up **A4** to interfere with other moving parts nor to hit cover **M2**. Then securely tighten the screw **N5** and close the cover plate **M2**.

SETTING LOOPER THREAD STRIPPER:

The looper thread stripper **B4** should normally be at the midpoint of the top and bottom extremes of its adjustment, as shown in Fig. 30.

To set the looper thread stripper, open the front cover plate **M2** and loosen the screw **H4**. Raise or lower the stripper **B4**, as required. Then securely tighten the screw **H4** and close the cover plate **M2**.

Make certain that none of the above adjustments cause take-up components to strike one another or the cover **M2**.

TO REMOVE AND REPLACE THE KNIVES

MACHINE 246K50 (See Fig. 31)

REMOVING STATIONARY KNIFE L4:

Loosen screw V4, Fig. 34, page 21 and draw the knife L4, Fig. 31 upward and out.

REPLACING STATIONARY KNIFE L4:

Push knife L4 downward in knife holder S4, until cutting edge of knife L4 is flush with top surface of throat plate U2. Securely tighten screw V4.

REMOVING MOVABLE KNIFE D4:

Remove clamp screw Q4, Fig. 32, the chip ejector O4, knife guard C4 and knife clamp Z3. Lift knife D4 from knife holder P4.

REPLACING MOVABLE KNIFE D4:

Slip knife in knife holder P4, replace knife clamp Z3, knife guard C4, the chip ejector O4, and clamp screw Q4. Press movable knife D4 downward against stationary knife L4 and securely tighten clamp screw Q4.

Adjust contact point of knives as instructed below.

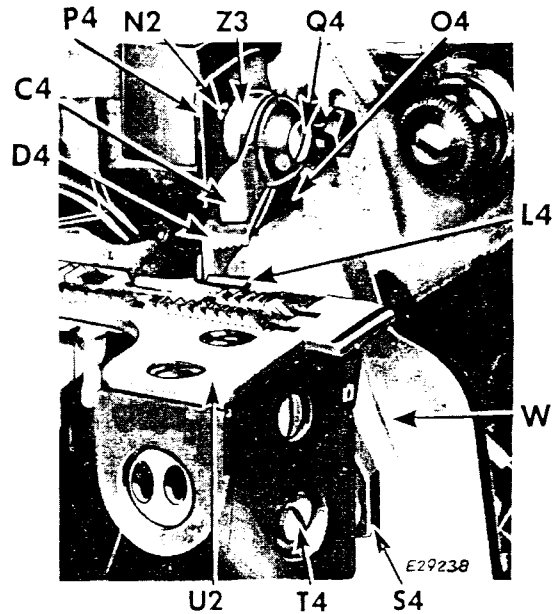

Fig. 31. Trimmer on Machine 246K50

MACHINE 246K51 (See Fig. 32)

REMOVING STATIONARY KNIFE L4:

Loosen screw V4 and draw knife L4 upward and out.

REPLACING STATIONARY KNIFE L4:

Push knife L4 downward in knife holder S4, until cutting edge of knife L4 is flush with top surface of throat plate U2. Securely tighten screw V4.

REMOVING MOVABLE KNIFE D4:

Remove clamping screw N2 and knife holder P4. Loosen screw Q4 and draw knife D4 down and out of knife holder P4.

REPLACING MOVABLE KNIFE D4:

Slip knife D4 up into holder P4 and tighten screw Q4. Fasten knife holder P4 to machine with clamping screw N2, as shown in Fig. 32.

Adjust contact point of knives as instructed below.

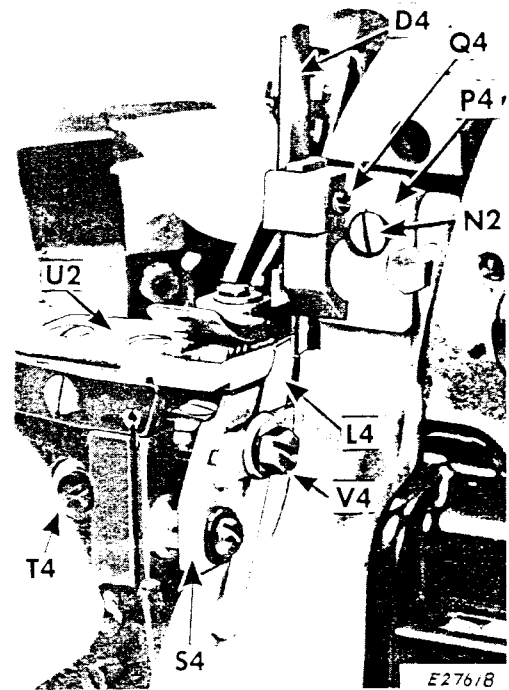
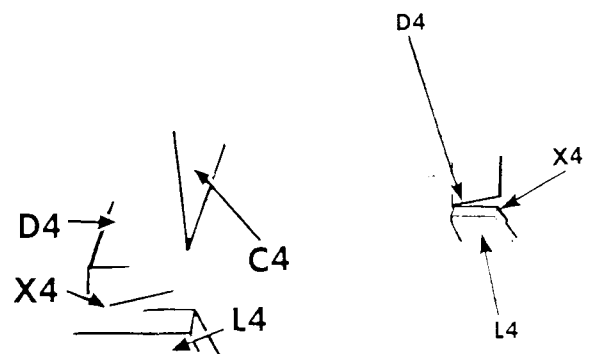

Fig. 32. Trimmer on Machine 246K51

ALL MACHINES (See Fig. 33)

SETTING KNIVES AT POINT OF CONTACT:

Turn the machine pulley over from you, until the lowest point X4, Fig. 33, of the cutting edge of the movable knife D4, just reaches the cutting edge of the stationary knife L4, as shown in Fig. 33. Loosen the set screw T4, Figs. 31 and 32, sufficiently to release the spring behind the stationary knife L4, permitting the stationary knife to make a tight spring contact with the movable knife D4. Then securely tighten the set screw T4.



Machine 246K50

Machine 246K51

Fig. 33. Contact Point of Knives

TO ADJUST THE TRIMMER ON MACHINE 246K50

(See Fig. 34)

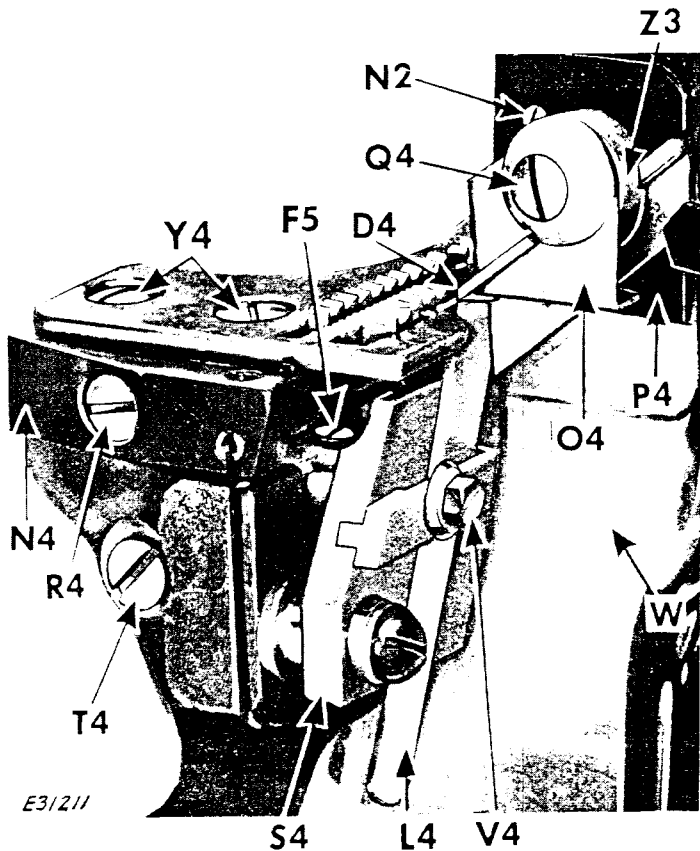

Fig. 34. Adjusting Trimmer

SETTING HEIGHT OF STATIONARY KNIFE:

Loosen screw **V4**, Fig. 34.

Raise or lower stationary knife **L4**, Fig. 34 in the knife holder **S4**, until the cutting edge of the knife is at the same level as top surface of throat plate **U2**.

Then securely tighten the screw **V4**.

WIDTH OF BIGHT:

The position of the stationary knife blade **L4**, Fig. 34 in relation to the needle determines the width of bight.

For some types of work, the width of bight must conform to the width of the chaining-off finger.

Before setting stationary knife **L4** for width of bight, loosen screw **Q4**, Fig. 34 and slide movable knife **D4** up into its holder out of possible contact with stationary knife. Tighten screw **Q4**.

SETTING STATIONARY KNIFE FOR WIDTH OF BIGHT:

To change the width of bight, loosen the screw **T4** and move the stationary knife holder **S4** toward the left or right, as required. Securely tighten the screw **T4**. Return movable knife **D4** to its correct position; setting it in relation to the stationary knife as described below.

SETTING MOVABLE KNIFE IN RELATION TO STATIONARY KNIFE POSITION:

Remove the clamp screw **Q4**, Fig. 34, the chip ejector **O4** and the knife clamp **Z3**. Loosen the screw **N2** and move the knife holder assembly **P4** toward the right or left as required to bring the cutting edge of the movable knife **D4**, at its lowest position, slightly below the cutting edge of the stationary knife **L4**, as shown in Fig. 34. Securely tighten the screw **N2**. Then replace the knife clamp **Z3**, the knife guard **C4**, the chip ejector **O4** and the clamp screw **Q4**. Then lightly press the movable knife **D4** downward against the stationary knife **L4** and tighten the screw **Q4**.

Loosen the screw **T4** sufficiently to release the spring behind the stationary knife **L4** permitting the stationary knife to make a tight spring contact with the movable knife **D4**. Then securely tighten the screw **T4**.

When knives require sharpening they may be removed and replaced as instructed on page 20 and sharpened as instructed on page 23.

See instructions on page 22 for **ANGULAR ADJUSTMENT** of stationary knife.

TO ADJUST THE TRIMMER ON MACHINE 246K51

(See Figs. 35 to 37)

SETTING HEIGHT OF STATIONARY KNIFE:

Loosen screw **V4**, Fig. 35.

Raise or lower knife **L4**, Fig. 36 in knife holder **S4**, until cutting edge of knife is at same level as top surface of throat plate.

Then securely tighten clamping screw **V4**.

WIDTH OF BIGHT:

The position of the stationary knife blade **L4**, Fig. 36 in relation to the needle determines the width of bight.

SETTING STATIONARY KNIFE FOR WIDTH OF BIGHT:

To change the width of bight, loosen the screw **T4**, Fig. 35 and move the stationary knife holder **S4**, Fig. 36 toward the left or right, as required. Securely tighten the screw **T4**.

SETTING MOVABLE KNIFE IN RELATION TO STATIONARY KNIFE SETTING:

Loosen set screw **N2** and set screw **Q4**, Fig. 36.

Raise or lower knife **D4** while moving knife holder assembly **P4**, Fig. 36 toward right or left, as required to bring cutting edge of movable knife **D4**, at its lowest position, in contact with and slightly below cutting edge **X4** of stationary knife **L4**, as shown in Fig. 36.

Securely tighten screw **Q4**.

While lightly pressing movable knife **D4** toward left against stationary knife **L4**, Fig. 36, tighten screw **N2**.

When knives require sharpening they may be removed and replaced as instructed on page 20.

See statement on page 23 concerning sharpening of knives.

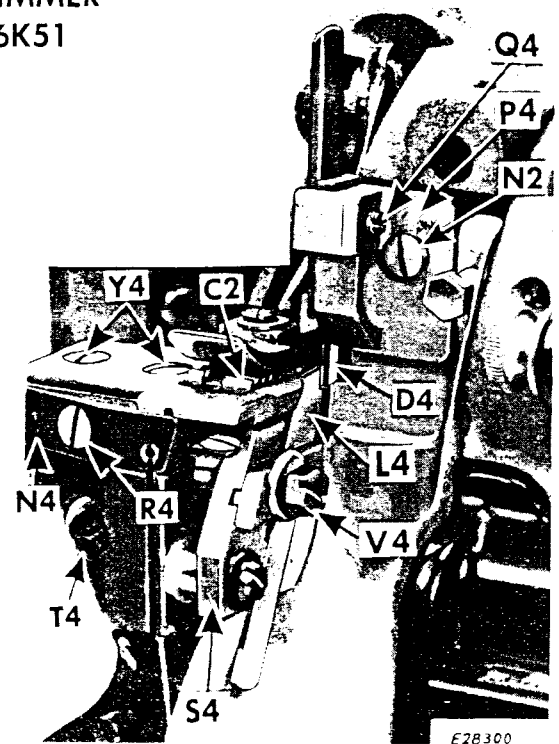

Fig. 35. Adjusting Width of Bight

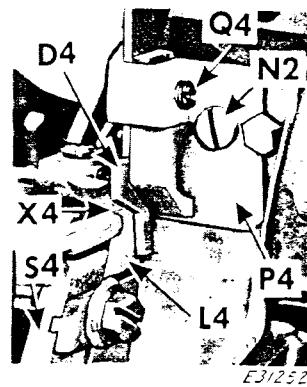

Fig. 36. Setting
Movable Knife in
Relation to
Stationary Knife

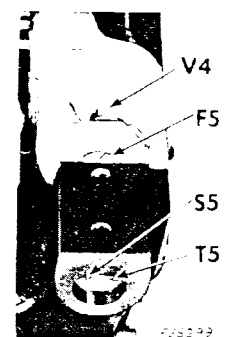

Fig. 37. Angular
Adjustment

ANGULAR ADJUSTMENT (All Machines):

To trim efficiently, knives must **contact each other at all points** along cutting edges.

To adjust, remove two screws **Y4**, Fig. 35 and remove throat plate; remove screw **R4** and guide **N4**, Fig. 35.

NOTE: On machines equipped with a needle guard, this guard must also be removed. When replacing needle guard, set it so that needle will just brush guard, as needle descends.

Remove feed dog **C2**, Fig. 35, and loosen screws **F5**, **S5** and **T5**, Fig. 37.

Align lower knife **L4** with upper knife **D4**, Fig. 36 and securely tighten screw **F5**, Fig. 37.

Tighten screws **S5** and **T5**, Fig. 37.

TO SHARPEN THE TRIMMER KNIVES ON MACHINES 246K50

(See Figs. 38 and 39)

Knives on **Machine 246K51** should be returned to your **SINGER Service Representative** or to a **SINGER** factory, when they require sharpening.

Knife Grinding Machine 701-9 (belt driven), is necessary for sharpening the knives used on **Machine 246K50**. The use of this grinder insures the correct bevel of the cutting edge of each knife.

If this Knife Grinder is not available, knives that require a new edge should be returned to your **SINGER Service Representative** or to a **SINGER** factory for sharpening.

Do not attempt to sharpen these knives by hand.

SHARPENING MOVABLE KNIFE D4:

Insert knife **D4**, **Fig. 38** in knife holder **B5**, **Fig. 38** on front of lever arm **A5**, **Fig. 38**. Allow approximately $1/16$ inch of the knife to extend beyond holder, for grinding. Then tighten thumb screw **Z4**, **Fig. 38**.

Turn thumb nut **E5**, **Fig. 38** over from you until the knife **D4** clears the grinding face **G5**, **Fig. 38**. While moving lever arm **A5** alternately back and forth, turn thumb nut **E5** as required, to bring the cutting edge of the knife **lightly** against the grinding face of the wheel.

Continue the back and forth motion of the lever arm, grinding off **only** enough to sharpen the cutting edge.

The movable knife is thus ground to a shearing edge, requiring no special setting in the machine to shear.

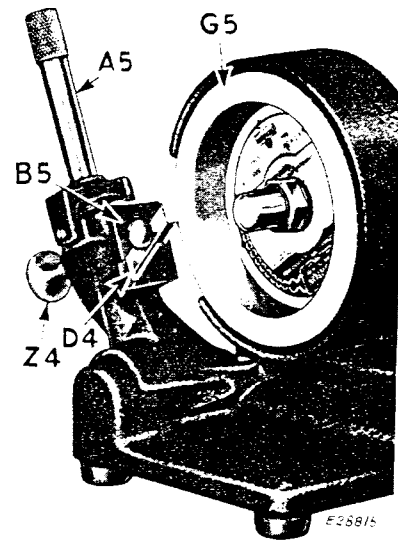

Fig. 38. Sharpening the Movable Knife

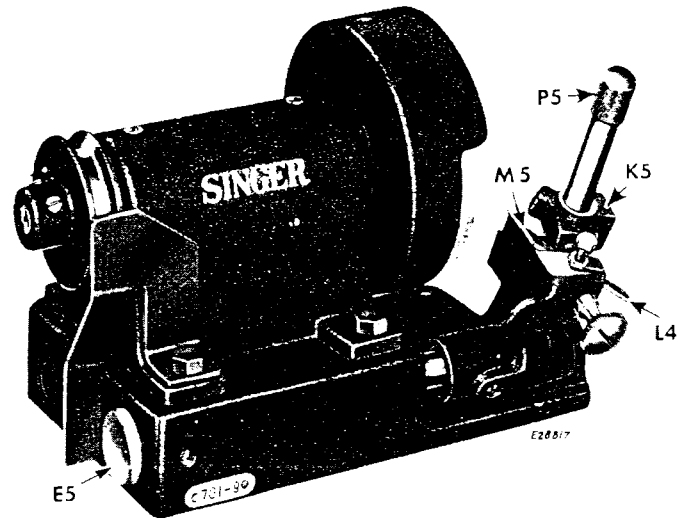

Fig. 39. Sharpening the Stationary Knife

SHARPENING STATIONARY KNIFE L4:

Insert knife **L4**, **Fig. 39** in knife holder **K5**, on rear of lever arm, so that its bevel **M5** is parallel with grinding face **G5** of grinding wheel. Allow approximately $1/16$ inch of the knife to extend beyond holder, for grinding. Then by turning knurled end **P5**, **Fig. 39** of lever arm, screw lever arm into knife holder **K5**, securing the knife. Sharpen the stationary knife as instructed above.



PARTS LIST

FOR

SINGER*

FOUR-THREAD

DUAL STITCH

OVEREDGING MACHINES

246k50 and 246k51



INSTRUCTIONS FOR ORDERING

In ordering from this List, the part number **MUST BE** quoted exactly as shown in the first column.
 A number always indicates the same part in whatever List it may appear, or for whatever machine.
 The code numbers (where shown) indicate the style of finish, as follows:—

Code No.	Description
801	Hardened, Polished, Nickel Plated and Buffed.
802	Polished, Nickel Plated and Buffed.
803	Hardened only.
804	Polished only.
805	Soft, not Polished.
806	Hardened and Polished.
807	Bright Rumbled and Nickel Plated.
808	Blued.
809	Nickel Plated only.
810	Hardened and Nickel Plated.
811	Brass Plated.
812	Oxidized.
813	Phosphate Coating Formed on Surface of Iron or Steel.
814	Cadmium Plated.
815	Copper Plated.
816	Zinc Plated.
817	Silver Plated.
818	Polished and Nickel Plated.
819	Black Oxide for Iron and Steel.
820	Black Nickel Plated only.
821	Chromium Plated.
822	Buffed and Chromium Plated.
823	Hardened, Polished, Buffed and Chromium Plated.
824	Hardened, Bright Rumbled and Nickel Plated.
825	Hardened, Bright Rumbled, Nickel Plated, Bright Rumbled and Chromium Plated.
826	Alumilite (Plain).
827	
828	Polished, Nickel Plated and Chromium Plated.
829	Hardened, Polished, Nickel Plated and Chromium Plated.
830	Heat Treated for Toughness.
831	Heat Treated for Toughness and Polished.
832	Heat Treated for Toughness and Nickel Plated.
833	Heat Treated for Toughness and Black Oxide.
834	Heat Treated for Toughness, Polished, Nickel Plated, Buffed and Chromium Plated.
835	
836	
837	
838	
839	Chrome Nickel, Satin Finish.
840	Hardened and Chrome Nickel, Satin Finish.
841	Hardened and Phosphate Coating Formed on Surface of Steel.
842	Hardened and Zinc Plated.
843	Hardened, Polished and Nickel Plated.
844	Hardened, Polished, Copper and Nickel Plated and Buffed.
845	Copper and Nickel Plated and Polished.
846	Copper and Nickel Plated only.
847	Hardened, Copper and Nickel Plated.
848	Copper and Brass Plated.
849	Copper Plated and Oxidized.
850	Hardened and Black Oxide for Iron and Steel.
851	Hardened, Polished, Nickel Plated, Buffed and Chromium Plated.
852	Polished, Nickel Plated, Buffed and Chromium Plated.
853	Hardened and Chromium Plated.
854	Polished and Chromium Plated.
855	Bright Rumbled, Nickel Plated, Bright Rumbled and Chromium Plated.

Continued on 28

INSTRUCTIONS FOR ORDERING—Continued.

New Code		Description	
856	Nickel and Chromium Plated.		
857	Copper and Chromium Plated.		
858	Heat Treated for Toughness, Nickel and Chromium Plated.		
859	Heat Treated for Toughness, Copper Plated and Oxidized.		
860	Nickel Plated and Buffed only.		
861	Alumilite (dyed)—Black.		
862	" (")—Light Almond Green.		
863	" (")—Dark Brown.		
864	" (")—Russet Brown.		
865	" (")—Dark Green.		
866	" (")—Medium Gold.		
867	Nickel-Satin Finish.		
868	Hardened and Nickel-Satin Finish.		
869	Commercial Finish for Allen Type Screws.		
870	Hard Coating on Aluminium.		
871	Brass Plated and Clear Lacquered.		

Code No.	Paint Colours	Code No.	Paint Colours
701	Gloss Black.	734	Pale Red.
702	Dull Black.	735	Emerald Green.
703	Brown.	736	Green Metallic.
704	Grey Wrinkle.	737	Light Beige Satin Matte.
705	Beige Wrinkle.	738	Copper Tan.
706	Black Wrinkle.	739	Buff.
707	Light Green.	740	White.
708	Dark Green.	741	Dark Fawn.
709	Dark Beige.	742	Plum.
710	Light Beige.	743	Birch Brown.
711	Oyster White.	744	Satin Black.
712		745	Gold-Buff.
713	Bright Cherry Red.	746	Blue-Grey.
714	Light Ivory.	747	Medium Gold.
715	Peacock Blue.	748	Sand.
716	Bright Yellow.	749	Khaki.
717	Slate Grey.	750	Flame Red.
718	Deep Brown.	751	Brite Green.
719		752	Sage Green.
720	Dark Brown.	753	Mist Green.
721	Aluminium.	754	Ice Green Metallic.
722	Dark Grey.	755	Dark Beige Metallic.
723	Light Grey Beige.	756	Shell Pink.
724	Rosewood Brown.	757	Surf Green.
725	Light Bisque.	758	Colonial Rose.
726	Light Fawn.	759	Cream.
727		760	Oak Brown.
728	Grey Metallic.	761	Deep Fawn.
729	Russet Brown.	762	Medium Green.
730	Pale Green.	763	Light Green Metallic.
731	Light Almond Green.	764	Light Gold.
732	Dusty Bisque.	765	Persimmon.
733	Chocolate Brown.	766	Mahogany Brown.

PARTS MARKED THUS (⊕) ARE FURNISHED ONLY WHEN THE REPAIRS ARE
MADE AT FACTORY.

Parts Complete for Machine No. 246K50

FOR TRIMMING AND OVEREDGING BATHING SUITS, HOUSE DRESSES AND SIMILAR ARTICLES. TWO NEEDLES, TWO LOOPERS. MAKES A FOUR-THREAD DUAL-STITCH TYPE 507. DISTANCE BETWEEN NEEDLES IS FIXED AT .109 INCHES. BIGHT ADJUSTABLE FROM 3/32" TO 7/32". MATERIAL UP TO 1/4" CAN BE STITCHED. SPEED UP TO 5,500 S.P.M. DEPENDING ON MATERIALS USED AND OPERATION PERFORMED.

Part No.	Plate	Description
164864	24881	Chain Cutter Chain Retainer (spring)
665-809	24881	" " " " (") Screw
164865	24881	Chain Cutter with Chain Retainer, complete. Nos. 164861, 164863, 164864 and two 665-809
164863	24881	Chain Cutter Holder
164861	24881	" " Knife
665-809	24881	" " " Screw
164648	—	" " (only supplied when specified on order)
164001	24878	Chip Guard
1209-809	24878	" " Screw (lower)
140509-809	24878	" " (upper)
164613	24878	Cloth Plate
164002-701	24878	" " Extension
51408-809	24878	" " " Screw
1700-809	24878	" " " " Nut
931084	24878	" " " " Lock Washer
164205	24878	" " Lock Spring
1700-809	24878	" " " " Nut
931084	24878	" " " " Lock Washer
1250-830	24878	" " " " Screw Stud
164104	24878	" " Plunger
164105	24878	" " " Spring
624-830	24878	" " " Set Screw
164106	24878	" " Position Collar with two 624-830
624-830	24878	" " " " Set Screw
164614	24878	Cloth Plate with Extension, complete. Nos. 164002-701, 164205, 164613, two each 1700-809, 51408-809 and 931084
164003	3074	Feed Bar Hinge Pin (eccentric)
1389-830	3074	" " " " Set Screw
164004	3074	" " Slide Block (back)
1628-803	3074	" " " " (") Nut
17022	3074	" " " " (") " Washer
164366	3074	" " " " (front)
164687	3074	" (back) Bar with 164010
164017	3074	" (") " Connection
164008	3074	" (") " " Bearing
164009	3074	" (") " " Hinge Screw Stud
1671-803	3074	" (") " " " " Nut
164010	3074	" (") " " " " Position Pin
164615	3072	" (") Dog Section (left)
164616	3072	" (") " " (right)
1100-830	3072	" (") " " (") Screw
164617	3072	Feed (back) Dog, complete. Nos. 1100-830, 164615 and 164616

PARTS FOR MACHINE No. 246K50

Part No.	Plate	Description
1454-806	3072	Feed (back) Dog Screw
164915	3074	" (") Eccentric
NOTE.—Feed (back) Eccentric No. 164915 is furnished in 4 to 16, 18, 20, 22, 24, 28, 32, 36, 40, 45, 50, 60, 70, 80 and 100 stitches to the inch. Unless otherwise stated No. 164915 (10 stitches to the inch) is supplied regularly.		
164006	3074	Feed (front) Bar with 164010
164007	3074	" (") " Connection
164018	3074	" (") " " Bearing
164009	3074	" (") " " Hinge Screw Stud
1671-803	3074	" (") " " " " " Nut
164010	3074	" (") " " " " " Position Pin
164370	—	Feed (back) and (front) Bars, complete, Nos. 164006 to 164008, 164017, 164018, 164366, 164687, two each 1671-803, 164004 and 164009
165108	3072	Feed (front) Dog
1454-806	3072	" (") " Screw
164915	3074	" (") Eccentric
NOTE.—Feed (front) Eccentric No. 164915 is furnished in 4 to 16, 18, 20, 22, 24, 28, 32, 36, 40, 45, 50, 60, 70, 80 and 100 stitches to the inch. Unless otherwise stated No. 164915 (10 stitches to the inch) is supplied regularly.		
164520	3074	Feed Eccentric Cover
164704	3074	" " " Bracket
164705	—	" " " " 164704 with 164023
157-803	3074	" " " " Screw
629-810	3074	" " " Hinge Screw
164401	3074	" " " Latch Spring
227-809	3074	" " " " " Screw
164023	3074	" " Oil Wick
164706	3074	" " Cover, complete, for use with eccentrics of 4 stitches and above, Nos. 629-810, 164401, 164520, 164705 and two 227-809
164966	3076	Feed Lifting and Knife (movable) Eccentric
164455	24881	Finger Guard (for 246K50 Machine only)
164456	24881	" " Adaptor (for 246K50 Machine only)
1259-830	2870	" " " Screw (for 246K50 Machine only)
1423-809	24881	" " " Screw (for 246K50 Machine only)
164556	3073	Knife (movable, serrated) (2) (1 in machine, 1 sent as spare)
164027	3073	" (") Clamp
140050-803	3073	" (") " Screw
164028	3073	" (") Guard (lower)
164458	3073	" (") " (upper)
164029	3073	" (") Holder
198-809	3073	" (") " Screw
164030	3073	" (") " " Bearing
164950	3073	" (") Lever with 620-830
164951	—	" (") " 164950 with 132583, 164035, 164136 and 164963
164032	3073	" (") " Bearing
447-830	3073	" (") " " Set Screw (long)
624-830	3073	" (") " " " (short)

PARTS FOR MACHINE No. 246K50

Part No.	Plate	Description
164373-728	2870	Knife (movable) Lever Cover and Presser Bar (upright) Housing with 1259-830
50073-809	2870	" (") " " " Presser Bar (upright) Housing Screw (2)
164885	—	Knife (movable) Lever Cover and Presser Bar (upright) Housing, complete, Nos. 50060-810, 164137, 164139, 164142 to 164144, 164194, 164373-728 and 164884
164180	24881	Knife (movable) Lever Guide
164181	24881	" (") " " " Holder with two 140239-830
164824	24881	" (") " " " " 164181 with 197-809, 164180, 164823 and 164827
140239-830	24881	Knife (movable) Lever Guide Holder Set Screw
164823	24881	" (") " " " " Thread Tube
447-830	24881	" (") " " " " " Set Screw
197-809	24881	" (") " " " " Screw
132583	3073	" (") " " " " Hinge Pin with 132584
132584	3073	" (") " " " " Oil Wick
620-830	3073	" (") " " " " Set Screw
164034	3073	" (") " " " " Stud
164035	—	" (") " " " " 164034 with 164036 and 164269
164036	3073	" (") " " " " Oil Wick (long)
164269	—	" (") " " " " " " (short)
447-830	3073	" (") " " " " " Set Screw (back)
1143-830	3073	" (") " " " " " " (top)
164728	3073	" (stationary) wide (2) (1 in machine, 1 sent as spare)
164744	3073	" (") Clamping Gib
140788-803	3073	" (") " " " " Screw
3146	3073	" (") " " " " " Washer
164746	3073	" (") Holder
164747	—	Knife (stationary) Holder (adjustable), complete, Nos. 742-806, 164745 and 164746
164748	3073	Knife (stationary) Holder (adjustable) with Gib, complete, Nos. 3146, 140788-803, 164744 and 164747
164590	3073	Knife (stationary) Holder Adjusting Stud
190-805	3073	" (") " " " " " Cap Screw
39541	3073	" (") " " " " " " Washer
164745	3073	" (") " " " " " Body with two 50611-803
50611-803	3073	" (") " " " " " Position Screw
742-806	3073	" (") " " " " " Screw
164042	3073	" (") " " " " " Sleeve
140088-805	3073	" (") " " " " " Screw
175032	3073	" (") " " " " " Washer
164043	3073	" (") " " " " " Spring
164525	3073	" (") " " " " " Stud
164619	3075	Looper (left hand)
164046	3075	" (") Carrier with 460-830, 50379-806 and 164202
164660	3075	" (") " " " Holder with 1083-803, 140393-830 and 140596-830
164661	—	" (") " " " " 164660 with 1324-803, 59456 and 164046

PARTS FOR MACHINE No. 246K50

Part No.	Plate	Description
1083-803	3075	Looper (left hand) Carrier Holder Clamping Screw
140596-830	3075	" (" ") " " Set Screw (left)
140393-830	3075	" (" ") " " " " (right)
1324-803	3075	" (" ") " Screw
460-830	3075	" (" ") " " Set Screw
59456	3075	" (" ") " " Washer
164048	3075	" (" ") Driving Shaft
164049	3075	" (" ") " " Bushing (back)
140394-805	3075	" (" ") " " " (") Cap Screw
164293	3075	" (" ") " " " (") " "
		Washer (fibre)
164737	3075	" (" ") " " " (front)
164051	3075	" (" ") " " Crank with 1083-803
1083-803	3075	" (" ") " " Clamping Screw
164052	3076	" (" ") " " Connection with two
		each 171-830 and 140159-830
164215	—	" (" ") " Shaft Crank 164051 with 164052
171-830	3076	" (" ") " " Connection Cap
		(lower) Screw
140159-830	3076	" (" ") " " Connection Cap
		(upper) Screw
164067	3075	" (" ") " " Key
1324-803	3075	" (" ") " " " Screw
45057	3075	" (" ") " " " Washer
164053	3075	" (" ") " " Thrust Bearing
164739	3075	" (" ") " " Oil Ring (rubber)
164740	3075	" (" ") " " " Spacer
50379-806	3075	" (" ") Set Screw
164202	3075	" (" ") Stop Pin
165055	3072	" (" ") Thread Tube
853-830	3072	" (" ") " " Set Screw
164375	3075	" (right hand)
164056	3075	" (" ") Carrier with 50370-830
164828	3075	" (" ") Connection
164829	—	" (" ") " " Guide Bar, Nos.
		1700-809, 50420-830, 164785, 164786 and 164828
164952	3075	Looper (right hand) Carrier Connection Guide Bar Bracket
		with two 462-830 and 51369-803
51369-803	3075	Looper (right hand) Carrier Connection Guide Bar Bracket
		Clamping Screw
914-803	3075	" (" ") " " " Bar Bracket
		Screw (left)
1057-830	3075	" (" ") " " " Bar Bracket
		Screw (right)
462-830	3075	" (" ") " " Guide Bar Set Screw
		(for 246K50 Machine only)
164785	3075	Looper (right hand) Carrier Connection Guide Bar Oil Con-
		trolling Screw Seat (brass)
50420-830	3075	" (" ") " Connection Guide Bar Oil Plug
		Screw
1700-809	3075	" (" ") " " " Oil Plug
		Screw Nut
164786	3075	" (" ") " " Guide Bar Oil Wick
164061	3075	" (" ") " " Hinge Stud with
		1019-830

PARTS FOR MACHINE No. 246K50

Part No.	Plate	Description
1443-809	3075	Looper (right hand) Carrier Connection Hinge Stud Cap Screw
164397	3075	" (" ") " " " " Adjusting Pin
1019-830	—	" (" ") " " " " Adjusting Pin Set Screw
132565	3075	" (" ") " Hinge Pin
165000	—	" (" ") " " Oil Pad (felt)
50370-830	3075	" (" ") " " Set Screw
164062	3075	" (" ") Driving Lever with 1083-803 and two 140596-830
164953	—	" (" ") " " 164062 with 1443-809, 1700-809, 132565, 164056, 164061, 164068, 164397, 164829 and 164952
1083-803	3075	Looper (right hand) Driving Lever Clamping Screw
140596-830	3075	" (" ") " " Set Screw
164063	3075	" (" ") " Shaft
164049	3075	" (" ") " Bushing (back)
140394-805	3075	" (" ") " " (") Cap Screw
164293	3075	" (" ") " " (") " Washer (fibre)
164738	3075	" (" ") " " (front)
164066	3075	" (" ") " Crank with 1083-803
164216	—	" (" ") " " 164066 with 164052
1083-803	3075	" (" ") " Clamping Screw
164052	3076	" (" ") " " Connection with two each 171-830 and 140159-830
171-830	3076	" (" ") " Shaft Crank Connection Cap (lower) Screw
140159-830	3076	" (" ") " " Connection Cap (upper) Screw
164067	3075	" (" ") " " Key
1324-803	3075	" (" ") " " Screw
45057	3075	" (" ") " " Washer
164053	3075	" (" ") " Thrust Bearing
164739	3075	" (" ") " Oil Ring (rubber)
164740	3075	" (" ") " " Spacer
164068	3075	" (" ") Locking Screw Stud
1700-809	3075	" (" ") " " Nut
164219	3075	" (" ") Position Collar with 904-830
904-830	3075	" (" ") " Set Screw
+164954-728	—	Machine Frame
+164955	—	Machine Frame, complete, Nos. 140396-805, 164077, 164954-728, 165057 and three 140395-805
164074	24813	Machine Frame Bottom Cover
164075	24813	" " " " Gasket
914-803	24813	" " " " Screw (13)
+165056-701	—	Bracket
+165057	—	" " " " 165056-701 with 164207 and two 187-805
164207	3053	" " " " Key
187-805	3053	" " " " Screw
140396-805	3053	" " " " Screw (large)
164077	3053	" " " " (") Washer (fibre)
164229	3053	" " " " (") " (felt)
140395-805	3053	" " " " (small)

PARTS FOR MACHINE No. 246K50

Part No.	Plate	Description
51369-809	24885	Machine Frame Top Cover Screw (3)
164231	3076	" Pulley (round and "V" belt) with two 448-830
164071-701	3076	" " Cap
140416-819	3076	" " " Screw
448-830	3076	" " Set Screw
Catalogue 1265	—	Needles, two size 18 (151×7) NOTE.—Needles Catalogue 1265 (151×7) are supplied unless machine is ordered for 1/16" gauge when Needles, Catalogue 1266 size 9 (151×9) are fitted.
164621	2870	Needle Clamp
51768-803	2870	" Clamping Nut
175032-803	2870	" " " Washer
164622	2870	" Driving Shaft with 164625
164684	—	" " " 164622 with 51768-803, 164621, 164685 and 1750-803
164111	2870	" " " Bushing
164112	2870	" " " " Cap
164113	2870	" " " " Oil Lead
452-830	2870	" " " " " Hole Plug Screw
164114	2870	" " " " Crank with 1083-803 and two 140596-830
164115	2870	" " " " Ball
1083-803	2870	" " " " Clamping Screw
164217	3076	" " " " Connection with 164115, two each 157-830 and 171-830
157-830	3076	" " " " " Cap (lower) Screw
171-830	3076	" " " " " (upper) Screw
140596-830	2870	" " " " Set Screw
165060	—	" Guard (for .109 inch space between needles) (supplied with machine unless otherwise specified on order)
165061	—	Needle Guard (for 1/16 inch space between needles) (supplied only when specified on order) (for 246K50 Machine only)
165059	—	Needle Guard Holder
1083-805	—	" " " " Screw
50225-809	—	" " " " Screw
164685	2870	" Holder
164625	2870	" Stop Pin
164119	3076	Oil Agitator
164120-701	3053	" Cooler with two 164125
164121	3053	" " " Cover
164123	3053	" " " " 164121 with 164135
164122	3053	" " " " Gasket
145-809	3053	" " " " Screw
164124	3053	" " " " Gasket
164125	3053	" " " " Oil Pipe
164126	3053	" " " " Tube with 138269 and 164128
164736	—	" " " " " 164126 with 51630 and 164127
164127	3053	" " " " " Coupling
51630	3053	" " " " " Lock Nut
+138269	—	" " " " " Sleeve
164128	—	" " " " " Wick
51139-809	3053	" " " " " Screw (long) (2)
1324-809	3053	" " " " " (short)

PARTS FOR MACHINE No. 246K50

Part No.	Plate	Description
164135	3053	Oil Cup for filling machine
164607	3073	" Deflector
164131	3053	" Sight Gauge Background Disc
164132	3053	" " " " " Gasket
164133	3053	" " " Window
164132	3053	" " " " Gasket
164134	3053	" " " " Retainer
164132	3053	" " " " " Gasket
1485-809	3053	" " " " " Screw (2)
164136	3073	Presser Bar Bracket
164137	2870	" " Lifting Bracket with 462-830, 624-830 and 51846
51846	2870	" " " " Roller and Stud
624-830	2870	" " " " Set Screw (long)
462-830	2870	" " " " " " (short)
164884	2870	" " " Lever
164139	2870	" " " " Spring
140228-803	24813	" " " " Stop Screw
1637-810	24813	" " " " " " Nut
164640	24881	" " (swing-out)
164141	24881	" " (") Lifting Screw Stud
1700-809	24881	" " (") " " " Nut
164142	2870	" " (") Opening Lever
50060-810	2870	" " (") " " Hinge Screw
140510-803	24881	" " (") Pivot Screw
164351	24881	" " (") " " Locking Plate
51362-830	24881	" " (") " " " " Screw
164143	2870	" " (upright)
164144	2870	" " (") Spring
164626	3072	" Foot Body
164146	3072	" " Chaining-off Finger
164147	3072	" " Clamping Plate
50225-809	3072	" " " " Screw
164360	3072	" " Guide (for 246K50 Machine only)
50169-809	3072	" " " " Screw (for 246K50 Machine only)
164627	3072	Presser Foot with Chain Cutter, complete, Nos. 50169-809, 50225-809, 164146, 164147, 164360 and 164626
164194	2870	Pressure Regulating Thumb Screw
2102	24885	Tension (heavy) Disc
164155	24885	" (") Regulating Thumb Nut
50133-803	24885	" (") Screw Stud
1700-809	24885	" (") " " Nut
164156	—	" (") " " 50133-803 with 164155
164161	24885	" (") Spring
59537	24885	" (") " Bushing
164158	24885	" (") " Cover
164162	24885	Tension (heavy) complete, Nos. 59537, 164156, 164158, 164161 and two 2102 (3)
2102	24885	Tension (light) Disc
164155	24885	" (") Regulating Thumb Nut
50133-803	24885	" (") Screw Stud
164156	—	" (") " " 50133-803 with 164155
164157	24885	" (") Spring
59537	24885	" (") " Bushing
164158	24885	" (") " Cover

PARTS FOR MACHINE No. 246K50

Part No.	Plate	Description
164160	24885	Tension (light) complete, Nos. 59537, 164156 to 164158 and two 2102
164285	24885	Tension (looper thread) Thread Guide (left)
164286	24885	" (" ") " " (right)
164418	24885	" Thread Eyelet
164628	24885	" " Guide (double)
1353-830	24885	" " " Screw
164629	24885	" " " Spacing Block
164630	24885	Tension (double) complete, Nos. 164628, two each 1700-809 and 164162
164825	24881	Thread Eyelet (needle thread)
164826	24881	" " (" ") Holder
164827	—	" " (" ") " 164826 with 1607-809 and 164825
1607-809	24881	" " (" ") Nut
140239-830	24881	" " (" ") Set Screw
164091	3075	" (looper, right hand) Stripper and Take-up with 164555
164163	24761	" (" " ") " " " Eyelet (adjustable)
1443-809	24761	" (" " ") " " " Eyelet (adjustable) Screw
164555	—	" (" " ") " " Take-up Guide Wire
187-805	3075	" (" " ") " " " Screw
17022	3075	" (" " ") " " " Washer
164164	24761	" (" " ") Thread Eyelet (movable)
1423-809	24761	" (" " ") " " Screw
164165	24761	" (" " ") " " (stationary)
1607-809	24761	" (" " ") " " (") Nut
164166	24761	" (" " ") Tube
624-830	24761	" (" " ") " Set Screw
164167-701	24761	" (") Plate with 624-830
164168	24761	" (") " Cover
164206	—	" (") " " 164168 with 164169 and 164170
164169	24761	" (") " " Hinge
164170	24761	" (") " " " Pin
164171	24761	" (") " " Spring
332-809	24761	" (") " " " Screw
896-830	24761	" (") " " Screw (2)
164173	24761	" (") " Thread Bushing
50318-818	24761	" (") " " " Screw
164174	—	Thread (looper) Plate, complete, Nos. 1423-809, 1443-809, 1607-809, 50318-818, 164163 to 164167, 164173, 164206, two each 332-809 and 164171
164175	3075	Thread (looper) Take-up
164176	3075	" (") " " Plate
190-805	3075	" (") " " Screw (lower)
1443-809	3075	" (") " " " (upper)
164151	3073	" (needle) Controller
164963	3073	" (") " " Lever
1443-809	3073	" (") " " Screw (2)
164632	3072	Throat Plate
164805	3072	" " Guide with 853-830

PARTS FOR MACHINE No. 246K50

Part No.	Plate	Description
1454-805	3072	Throat Plate Guide Screw
1094-806	3072	" " Screw (2)

Parts Special to Machine No. 246K51

FOR TRIMMING AND OVEREDGING BATHING SUITS, HOUSE DRESSES AND SIMILAR ARTICLES. TWO NEEDLES, TWO LOOPERS. MAKES A FOUR-THREAD DUAL-STITCH TYPE 507. DISTANCE BETWEEN NEEDLES IS FIXED AT .109 INCHES. BIGHT ADJUSTABLE FROM 3/32" TO 9/32". MATERIALS UP TO 1/4" CAN BE STITCHED. SPEED UP TO 5,500 S.P.M. DEPENDING ON MATERIALS USED AND OPERATION PERFORMED.

Part No.	Plate	Description
165109	3077	Feed (front) Dog
164966	3076	" Lifting and Thread Needle Controller Lever Eccentric
164809	3077	Knife (movable) (2) (1 in machine, 1 sent as spare)
164810	3077	" (") Holder with 1147-830
164811	3077	" (") " Gib
1147-830	3077	" (") " " Screw
176-809	3077	" (") " " Screw
164812	—	Knife (movable) Lever Cover and Presser Bar (upright) Housing, complete, Nos. 50060-810, 164137, 164139, 164142, 164143, 164194, 164373-728, 164814, 164815 and 164884
164813	3077	Knife (stationary) (2) (1 in machine, 1 sent as spare)
164781	3077	Looper (right hand) Carrier with 50370-830
164782	3077	" (") " Connection
164783	—	" (") " and Guide Bar 164782 with 1700-809, 50420-830, 164785 and 164786
164784	3077	Looper (right hand) Carrier Connection Guide Bar Bracket with 51369-803
164787	—	" (") Driving Lever 164062 with 1443-809, 1700-809, 132565, 164061, 164068, 164397, 164781, 164783 and 164784
164969	3076	Machine Frame Rotary Shaft
164970	—	" " " " 164969 with 164097, 164215 to 164217, two each 164093 and 164232
164814	2870	Presser Bar (upright) Spring
164815	2870	" (") " Spacing Collar
164816	3054	" Foot Body
164817	3054	Presser Foot, complete, Nos. 50225-809, 164146, 164147 and 164816
140180-809	3054	Presser Foot Screw
164801-701	—	Thread (looper) Plate with 624-830
164802	—	Thread (looper) Plate, complete, Nos. 1423-809, 1443-809, 1607-809, 50318-818, 164163 to 164166, 164173, 164206, 164801-701, two each 332-809 and 164171
164818	3054	Throat Plate

THESE MACHINES CAN ALSO BE FURNISHED WITH A
GATHERING DEVICE AT AN ADDITIONAL CHARGE
IF SPECIFIED ON ORDER.

Fittings

FOR 246K50 AND 246K51 MACHINES

FOR GATHERING.

Part No.	Plate	Description
164686	3078	Feed Bar Hinge Pin Collar with 735-830
735-830	3078	" " " " " " Set Screw
164687	3078	" (back) Bar with 164010
164690	3078	" (front) Dog Controlling Lever
164691	3056	" (") " " " " Ball Joint
164692	3056	" (") " " " " " " " Position Plate (back)
164693	3056	" (") " " " " " " " " Plate (front)
190-819	3056	" (") " " " " " " " " Screw
164694	3078	" (") " " " " " " " " Connection
164664	3078	" (") " " " " " " " " Bearing
164665	3078	" (") " " " " " " " " Hinge Screw Stud
164695	3078	" (") " " " " " " " " Stud
1700-819	3078	" (") " " " " " " " " " Nut
164696	3078	" (") " " " " " " " " Segment
164697	—	" (") " " " " " " " " 164696 with 164700 and two 50388-830
164698	—	Feed (front) Dog Controlling Lever Segment 164697 with 1454-806 and 164701 to 164703
164699	3078	Feed (front) Dog Controlling Lever Segment Bracket
164700	—	" (") " " " " " " " " 164699 with 1700-819 and 164695
164701	3078	Feed (front) Dog Controlling Lever Segment Guide
164702	3078	" (") " " " " " " " " " Adjusting Cam
164703	3078	" (") " " " " " " " " " " Cam Roller
1454-806	3078	" (") " " " " " " " " " Guide Adjusting Cam Roller Screw
50388-830	3078	" (") " " " " " " " " Segment Screw
164704	3074	" Eccentric Cover Bracket
164705	—	" " " " " " " " " 164704 with 164023
164023	3074	" " " " " " " " " Oil Wick
164707	3056	Gathering Device Indicator Plate
140077-819	3056	" " " " " " " " " Screw
164708	3056	" " " " " " " " " Lever and Indicator
164856	—	" " " " " " " " " 164708 with 164691 to 164693 and two 190-819
103-819	3056	" " " " " " " " " Chain Screw
164709	3056	" " " " " " " " " Extension
50117-830	3056	" " " " " " " " " " Screw

FITTINGS FOR 246K50 AND 246K51 MACHINES—Continued.

Part No.	Plate	Description
164710	3056	Gathering Device Lever and Indicator Guide Plate
140764-819	3056	" " " " " " " " Screw
140185-819	3056	" " " " " " " " Hinge Screw
164711	3056	" " " " " " " " Spring
50101-819	3056	" " " " " " " " " Screw
164712	3056	" " " " " " " " Stop (lower)
1209-819	3056	" " " " " " " " " (") Screw
1547-819	3056	" " " " " " " " " (") " Nut
164713	3056	" " " " " " " " " (upper)
1209-819	3056	" " " " " " " " " (") Screw
1547-819	3056	" " " " " " " " " (") " Nut
164717	3056	Machine Frame Cover (back)
164718	—	" " " " (") 164717 with 1637-810 and 140228-803
164719	—	" " " " (") 164718 with 103-819, 50101-819, 50117-819, 140185-809, 164709 to 164713, 164856, two each 1209-819, 1547-819 and 140764-819
164723	3079	Presser Bar Lifting Lever
140228	3056	" " " " " " " " Stop Screw
1637-819	3056	" " " " " " " " " Nut
164889	—	Conversion Kit, Nos. 164664, 164665, 164686, 164687, 164690, 164694, 164698, 164705, 164707, 164719, 164723 and four 140077-819

THE FOLLOWING FITTINGS AND RELATED PARTS ARE USED WITH BUT NOT INCLUDED IN CONVERSION KIT 164889.

For .109 inch space between needles.

PRESSER FOOT WITH GATHERING BLADE ATTACHED.

164896	—	Feed (back) Dog Section (left)
164616	—	" (") " " (right)
1100-830	—	" (") " " (") Screw
164897	—	Feed (back) Dog, complete, Nos. 1100-830, 164616 and 164896
164898	—	Feed (front) Dog
164901	—	Presser Foot Body
164147	—	" " Clamping Plate
50225-809	—	" " " " Screw
164725	—	" " Gathering Plate
662-809	—	" " " " Screw

FITTINGS AND RELATED PARTS—Continued.

Part No.	Plate	Description
164902	—	Presser Foot with Gathering Blade, complete, Nos. 50225-809, 164147, 164725, 164901 and two 662-809
164632	3079	Throat Plate 5/32" bight
164899	3079	" " 3/32" bight
164900	3079	" " 1/8" bight
164805	—	" " Guide

SWING-UP ATTACHMENT AND FITTINGS

164903	3079	Feed (back) Dog Section (left)
164616	3079	" (") " " (right)
1100-830	3079	" (") " " (") Screw
164904	3079	Feed (back) Dog, complete, Nos. 1100-830, 164616 and 164903
164905	—	Feed (front) Dog
164871	3054	Gathering Plate (swing-up)
164872	3054	" " (") Holder
164873	3054	" " (") " Housing with 50292-803
1517-809	3054	" " (") " " Nut
442-830	3054	" " (") " " Stop Screw
1628-809	3054	" " (") " " " Nut
164874	3054	" " (") " " Support
50409-803	3054	" " (") " " Hinge Screw
49204	3054	" " (") " " Support Hinge Screw Friction Washer
1655-809	3054	" " (") " " Housing Support Hinge Screw Nut
164875	3054	" " (") " " Support Joint
1259-830	2870	" " (") " " " Set Screw
1264-803	3054	" " (") " " Stop Screw
164876	3054	" " (") Lifter
50318-809	3054	" " (") " Adjusting Screw
1772-809	3054	" " (") " " " Nut
164886	3054	" " (") " Lever (adjustable) with 1772-809 and 50318-809
140180-809	3054	" " (") Lifter Lever Screw
50169-803	3054	" " (") " Screw
165034	3054	" " (") Lifting Lever with 853-830
853-830	3054	" " (") " " Set Screw
217-809	3054	" " (") Screw
164877	—	" " (") Tension Spring
164878	3054	" " (") " " Pressure Adjust- ing Head (hexagon)
50292-803	3054	" " (") " Spring Pressure Adjust- ing Head Set Screw
164880	3054	Gathering Plate (swing-up) with Holder, Holder Housing and Housing Support, Nos. 217-809, 442-830, 1264-803, 1517-809, 1628-809, 1655-809, 49204, 50409-803, 140180-809, 164871 to 164878, 165034 and two 50169-803

SWING-UP ATTACHMENT AND FITTINGS—Continued.

Part No.	Plate	Description
164906	3079	Presser Foot Body
164146	3079	" " Chaining-off Finger
164147	3079	" " Clamping Plate
50225-809	3079	" " " " Screw
164907	3079	Presser Foot (hinged), complete, Nos. 50225-809, 164146, 164147 and 164906
164632	3079	Throat Plate 5/32" bight
164899	3079	" " 3/32" bight
164900	3079	" " 1/8" bight
164805	—	" " Guide

FITTINGS FOR 246K50 MACHINE

FOR INTERMITTENT GATHERING

FOR KNEE OR MANUAL CONTROL

FOR NINON, ORGANDY, TAFFETA AND COTTON MATERIALS

For .109 inch space between needles

164671	3051	Feed (back) Dog Section (left)
164672	3051	" (") " (right)
164673	3051	Feed (back) Dog, complete, Nos. 1100-830, 164671 and 164672
164674	3051	" (front) Dog
164566	3051	Gathering Plate (swing-out, pivoted)
164569	—	Gathering Plate (swing-out, pivoted), complete, Nos. 164566 to 164568
164649	3051	Gathering Plate (swing-out, pivoted) Arm
1425-809	3051	" " (" ") " Hinge Screw
42436	3051	" " (" ") " Washer
164573	3051	" " (" ") " Holder
164582	—	Gathering Plate (swing-out, pivoted) Arm Holder (adjustable), complete, Nos. 164573, 164581 and two 190-809
50267-813	3051	Gathering Plate (swing-out, pivoted) Arm Holder Screw (2)
164581	3051	" " (" ") " Seat
190-809	3051	" " (" ") " Screw
164567	3051	" " (" ") Holder
164570	3051	" " (" ") Bracket
50004-809	3051	" " (" ") " Screw
1550-809	3051	" " (" ") " Nut
934-802	3051	" " (" ") " Screw
164568	3051	" " (" ") Pin
164576	3051	" " (" ") Pull
1143-830	3051	" " (" ") Stop Screw
1700-803	3051	" " (" ") " Nut

FITTINGS FOR 246K50 MACHINE—Continued.

Part No.	Plate	Description
164650	—	Gathering Plate (swing-out, pivoted) with Arm and Holder, complete, Nos. 1143-830, 1425-809, 1700-803, 164569, 164570, 164576, 164582, 164649, two each 934-802, 1550-809, 50004-809 and three 42436
164655	3051	Gathering Plate (swing-out, solid)
164656	3051	Gathering Plate (swing-out, solid) with Arm and Holder, complete, Nos. 1143-830, 1425-809, 1700-803, 164576, 164582, 164649, 164655, two each 1550-809, 50004-809 and three 42436
NOTE.—No. 164656 will be furnished as regular with these Fittings unless otherwise specified.		
164651	3051	Gathering Plate Presser Lever
140210-803	3051	" " " " Hinge Screw
1521-819	3051	" " " " " " Nut
1377-803	3051	" " " " " " Screw Stud (eccentric)
1698-819	3051	" " " " " " (") Nut
24210	3051	" " " " " " (") "
		Washer
164652	3051	" " " " Pressure Bracket
164234	3051	" " " " " " Adjusting Slide
		(cylindrical)
140657-810	3051	" " " " " " Slide Screw
140457-803	3051	" " " " " " " "
		Locking Screw
164653	3051	" " " " " " Pressure Spring
51939	3051	" " " " " " Roller
51940	—	Gathering Plate Pressure Bracket Roller, complete, Nos. 51939 with 140658-806
140658-806	3051	Gathering Plate Pressure Bracket Roller Screw Stud
1700-809	3051	" " " " " " " " Nut
164578	3051	" " " " " " " " Support
164654	3051	Gathering Plate Pressure Bracket and Support, complete, Nos. 1377-803, 1521-819, 1698-819, 1700-809, 24210, 51940, 140210-803, 140457-803, 140657-810, 164234, 164578 and 164651 to 164653
164308	—	Knife (movable)
164819	3051	Presser Bar (swing-out)
164675	3051	" " " " " " Foot
164564	3051	" " " " " " Cord Guide (spring)
240-809	3051	" " " " " " " " Screw
164676	3051	Presser Foot, complete, Nos. 240-809, 164564 and 164675
140180-809	3051	" " " " " " " " Screw
164580	3051	Tension Extension Plate
140596-830	3051	" " " " " " " " Screw
1700-809	3051	" " " " " " " " Screw Stud Nut

FOR 246K50 MACHINE

For Producing 1/16 inch Space Between Needles

Part No.	Plate	Description
164633	3077	Feed (back) Dog Section (left)
164634	3077	" (") " " (right)
1100-830	3077	" (") " " (") Screw
164635	3077	Feed (back) Dog, complete, Nos. 1100-830, 164633 and 164634
164636	3077	" (front) Dog
Catalogue		
1266	—	Needles (2), Size 11 (151×9)
164637	3077	Needle Clamp
51720-803	3077	" Clamping Nut
164622	3077	" Driving Shaft with 164625
164638	—	" " " " 164622 with 51720-803, 164637 and 164639
164639	3077	" Holder
164625	3077	" Stop Pin
164626	3077	Presser Foot Body
164641	3077	" " Chaining-off Finger
164147	3077	" " Clamping Plate
164360	3077	" " Guide
50169-809	3077	" " " Screw
50225-809	3077	" " " Screw
164642	3077	Presser Foot, complete, Nos. 50169-809, 50225-809, 164147, 164360, 164626 and 164641
164682	3077	Throat Plate (1/8 inch bight) with 164683 (for needle 151×9, size 9 or under)
164643	—	Throat Plate (1/8 inch bight) (for needle 151×9, size 10 and above)
164683	—	Throat Plate Thread Finger

Accessories

Part No.	Plate	Description
164203	3080	Feed Eccentric Extractor NOTE.—(Only supplied when specified on order and at an extra charge).
164883	3080	Gauge NOTE.—(Only supplied when specified on order and at an extra charge).
Catalogue 1265	—	Needles, twelve, size 18 (151 × 7)
Catalogue 1265	—	Needles, twelve, size 9 (151 × 7) (supplied with 246K50 Machine when fitted for 1/16 inch gauge)
120342	3080	Oiler
164198	3080	Presser Bar Lifting Chain Spring (under table)
85318	3080	Screw Driver
164196	3080	Threader (6)
—	—	Tin of Oil (1 pint)
164204	3080	Tweezers
8908	3080	Wrench
164197	3080	(socket)
164831	3080	"

BELT GUARD (ADJUSTABLE)

(Supplied with machine)

164183	3049	Belt Guard
164199	3049	" Bracket (back)
164200	3049	" (front)
51326-809	3049	" Screw
164201	3049	Belt Guard (adjustable) complete, Nos. 164183, 164199, 164200, two each 51326-809 and wood screws 3/4 inch No. 7 F.H.

CHIP CHUTE

(Supplied only when specified on order at no extra charge)

168198	3049	Chip Chute with four wood screws 3/8 inch No. 6 F.H. Blacked
--------	------	--

FOOT LIFTER PARTS

The stands recommended for machines of Class 246K include a suitable treadle. If machine is fitted on a stand or other equipment which does not include a foot lifter treadle, orders should state that No. 4885 is to be supplied and it will be furnished without extra charge.

6439	3049	Chain 36" to 45" with 56864 and 56865 NOTE.—When ordering No. 6439 give length required.
4879	3049	Chain Connecting Link
56864	3049	" Hook (large)
56865	3049	" (small)
4881	3049	Treadle
4882	3049	" Shaft
4883	—	" Spring
4884	3049	" Stand
4885	3049	Treadle, complete, Nos. 4879, 4881 to 4884 and two wood screws 1" No. 16 F.H.

KNEE LIFTER PARTS

(Will be supplied in place of Foot Lifter if specified on order)

Part No.	Plate	Description
59324	3059	Chain (8" long) with 56865
56865	3059	" Hook (small)
2763	3059	Rock Shaft
12242	3059	" " Hanger with two wood screws 1" No. 10
143283	3059	" " Knee Arm
143284	3059	" " " " Hub with 356-803 and 140351-830
140351-830	3059	" " " " " Clamping Screw
356-803	3059	" " " " " Set Screw
143285	—	Rock Shaft Knee Arm, complete, Nos. 2767, 143283 and 143284
2767	3059	" " " " Plate with 356-803
356-803	3059	" " " " " Set Screw
6337	3059	" " " " Lifting Bracket with two 356-803
164729	3059	" " " " " Hook
356-803	3059	" " " " " Set Screw
356-803	3059	" " " " " Set Screw
2770	3059	" " " " Stop Dog with 356-803
356-803	3059	" " " " " Set Screw
164727	3059	Knee Lifter, complete, Nos. 2763, 6337, 59324, 143285, 164729, two each 2770 and 12242

MACHINE BASE

164184	3049	Machine Base with two each wood screws 3/4" No. 8 R.H. and 1 1/4" No. 6 F.H.
164188	3049	Machine Cushion (large) (2)
164189	3049	" (small) (2)
140418-805	3076	" Screw Stud (back)
657-805	3076	" " " (front)

THREAD UNWINDER No. 151163

FOR FOUR SPOOLS

(Supplied with machine)

228692	3060	Spool Pin
201528	—	" " Nut
82538	—	" " Washer
151023	3060	Spool Rest with 858-830, three each 82538, 201528-819 and 228692 (three spools)
225259	3060	Spool Rest with 82538, 201018-803, 201528-819 and 228692 (one spool)
150203	3060	" " Cushion (felt)
858-830	3060	" " Hub Set Screw
151024	3060	" " Rod
1122-803	3060	" " " Set Screw
201018-803	3060	" " Set Screw
151025	3060	" " Stand with two 1122-803 and three wood screws 1" No. 12 F.H.

THREAD UNWINDER No. 151163—Continued

Part No.	Plate	Description
151026	3060	Thread Guide (lower)
50311-803	3060	" " (") Holder Set Screw
151027	3060	" " (") Support with 50311-803
151028	3060	" " (upper, hollow)
151162	3060	" " (upper, solid)
151029	3060	" " (") Holder with four 453-830
151030	3060	" " Rod
453-830	3060	" " " Set Screw
453-830	3060	" " " Set Screw
151163	3060	Thread Unwinder, complete, Nos. 151023 to 151027, 151029, 151030, 151162, 225259, two 151028 and four 150203

Numerical List of Parts

Part No.	Page No.	Part No.	Page No.	Part No.	Page No.
103	40	1057	32	4882	46
145	35	1083	32, 33, 35	4883	46
157	30, 35	1094	38	4884	46
171	32, 33, 35	1100	29, 41, 42, 45	4885	46
176	39	1122	47	6337	47
187	33, 37	1143	31, 43	6439	46
190	31, 37, 40, 43	1147	39	8908	46
197	31	1209	29, 41	12242	47
198	30	1250	29	17022	29, 37
206	34	1259	30, 42	24210	44
217	42	1264	42	39541	31
227	30	1324	32, 33, 35	42436	43
240	44	1353	37	45057	32, 33
330	34	1377	44	49204	42
332	37	1389	29	50004	43
356	47	1423	30, 37	50060	36
442	42	1425	43	50073	31
447	30, 31, 34	1443	33, 37	50101	41
448	35	1454	30, 38, 40	50117	40
452	35	1485	36	50133	36
453	48	1517	42	50169	36, 42, 45
460	32	1521	44	50225	35, 36, 41, 43, 45
462	32, 36	1547	41	50267	43
620	31	1550	43	50292	42
624	29, 30, 36, 37	1607	37	50311	48
629	30	1628	29, 42	50318	37, 42
657	47	1637	36, 41	50370	33
662	41	1655	42	50379	32
665	29	1671	29, 30	50388	40
735	40	1698	34, 44	50409	42
742	31	1700	29, 32, 33, 36, 40, 43, 44	50420	32
853	32, 42	1772	42	50571	34
858	47	2102	36	50611	31
896	37	2763	47	51023	34
904	33	2767	47	51139	35
914	32, 33, 34	2770	47	51326	46
934	43	3146	31	51332	34
1019	33	4879	46	51362	36
1036	34	4881	46	51369	32, 34, 35

NUMERICAL LIST OF PARTS

Part No.	Page No.	Part No.	Page No.	Part No.	Page No.
51408	29	140457	44	164034	31
51630	35	140509	29	164035	31
51649	34	140510	36	164036	31
51720	45	140596	32, 33, 35, 44	164042	31
51768	35	140657	44	164043	31
51846	36	140658	44	164046	31
51939	44	140764	41	164048	32
51940	44	140788	31	164049	32, 33
56864	46	143283	47	164051	32
56865	46, 47	143284	47	164052	32, 33
59324	47	143285	47	164053	32, 33
59456	32	150203	47	164056	32
59537	36	151023	47	164061	32
82538	47	151024	47	164062	33
85318	46	151025	47	164063	33
120342	46	151026	48	164066	33
131056	34	151027	48	164067	32, 33
132565	33	151028	48	164068	33
132583	31	151029	48	164071	35
132584	31	151030	48	164074	33
138269	35	151162	48	164075	33
139026	34	151163	48	164077	33
140050	30	164001	29	164081	34
140077	40	164002	29	164082	34
140088	31, 34	164003	29	164083	34
140159	32, 33	164004	29	164086	34
140180	39, 42, 44	164006	30	164087	34
140185	41	164007	30	164091	37
140210	44	164008	29	164092	34
140228	36, 41	164009	29, 30	164093	34
140239	31, 37	164010	29, 30	164096	34
140346	34	164017	29	164097	34
140351	47	164018	30	164098	34
140393	32	164023	30, 40	164099	34
140394	32, 33	164027	30	164100	34
140395	33	164028	30	164101	34
140396	33	164029	30	164102	34
140416	35	164030	30	164103	34
140418	47	164032	30	164104	29

NUMERICAL LIST OF PARTS

Part No.	Page No.	Part No.	Page No.	Part No.	Page No.
164105	29	164163	37	164232	34
164106	29	164164	37	164234	44
164111	35	164165	37	164269	31
164112	35	164166	37	164285	37
164113	35	164167	37	164286	37
164114	35	164168	37	164293	32, 33
164115	35	164169	37	164308	44
164119	35	164170	37	164351	36
164120	35	164171	37	164360	36, 45
164121	35	164173	37	164366	29
164122	35	164174	37	164370	30
164123	35	164175	37	164373	31
164124	35	164176	37	164375	32
164125	35	164180	31	164397	33
164126	35	164181	31	164401	30
164127	35	164183	46	164418	37
164128	35	164184	47	164455	30
164131	36	164188	47	164456	30
164132	36	164189	47	164458	30
164133	36	164194	36	164515	34
164134	36	164196	46	164516	34
164135	36	164197	46	164520	30
164136	36	164198	46	164525	31
164137	36	164199	46	164555	37
164139	36	164200	46	164556	30
164141	36	164201	46	164564	44
164142	36	164202	32	164566	43
164143	36	164203	46	164567	43
164144	36	164204	46	164568	43
164146	36, 43	164205	29	164569	43
164147	36, 41, 43, 45	164206	37	164570	43
164151	37	164207	33	164573	43
164155	36	164214	34	164576	43
164156	36	164215	32	164578	44
164157	36	164216	33	164580	44
164158	36	164217	35	164581	43
164160	37	164219	33	164582	43
164161	36	164229	33	164590	31
164162	36	164231	35	164605	34

NUMERICAL LIST OF PARTS

Part No.	Page No.	Part No.	Page No.	Part No.	Page No.
164606	34	164656	44	164712	41
164607	36	164660	31	164713	41
164608	34	164661	31	164717	41
164609	34	164664	40	164718	41
164613	29	164665	40	164719	41
164614	29	164671	43	164723	41
164615	29	164672	43	164725	41
164616	29, 41, 42	164673	43	164727	47
164617	29	164674	43	164728	31
164619	31	164675	44	164729	47
164620	34	164676	44	164736	35
164621	35	164682	45	164737	32
164622	35, 45	164683	45	164738	33
164625	35, 45	164684	35	164739	32, 33
164626	36, 45	164685	35	164740	32, 33
164627	36	164686	40	164744	31
164628	37	164687	29, 40	164745	31
164629	37	164690	40	164746	31
164630	37	164691	40	164747	31
164632	37, 42, 43	164692	40	164748	31
164633	45	164693	40	164781	39
164634	45	164694	40	164782	39
164635	45	164695	40	164783	39
164636	45	164696	40	164784	39
164637	45	164697	40	164785	32
164638	45	164698	40	164786	32
164639	45	164699	40	164787	39
164640	36	164700	40	164801	39
164641	45	164701	40	164802	39
164642	45	164702	40	164805	37, 42, 43
164643	45	164703	40	164809	39
164648	29	164704	30, 40	164810	39
164649	43	164705	30, 40	164811	39
164650	44	164706	30	164812	39
164651	44	164707	40	164813	39
164652	44	164708	40	164814	39
164653	44	164709	40	164815	39
164654	44	164710	41	164816	39
164655	44	164711	41	164817	39

NUMERICAL LIST OF PARTS

Part No.	Page No.	Part No.	Page No.	Part No.	Page No.
164818	39	164906	43		
164819	44	164907	43		
164823	31	164915	30		
164824	31	164950	30		
164825	37	164951	30		
164826	37	164952	32		
164827	37	164953	33		
164828	32	164954	33		
164829	32	164955	33		
164831	46	164958	34		
164856	40	164959	34		
164861	29	164960	34		
164863	29	164961	34		
164864	29	164963	37		
164865	29	164966	30, 39		
164871	42	164967	34		
164872	42	164968	34		
164873	42	164969	39		
164874	42	164970	39		
164875	42	165000	33		
164876	42	165034	42		
164877	42	165055	32		
164878	42	165056	33		
164880	42	165057	33		
164883	46	165059	35		
164884	36	165060	35		
164885	31	165061	35		
164886	42	165108	30		
164889	41	165109	39		
164896	41	168198	46		
164897	41	175032	31, 35		
164898	41	201018	47		
164899	42, 43	201528	47		
164900	42, 43	225259	47		
164901	41	228692	47		
164902	42	931084	29		
164903	42				
164904	42				
164905	42				

ILLUSTRATIONS

2870 - 1/2

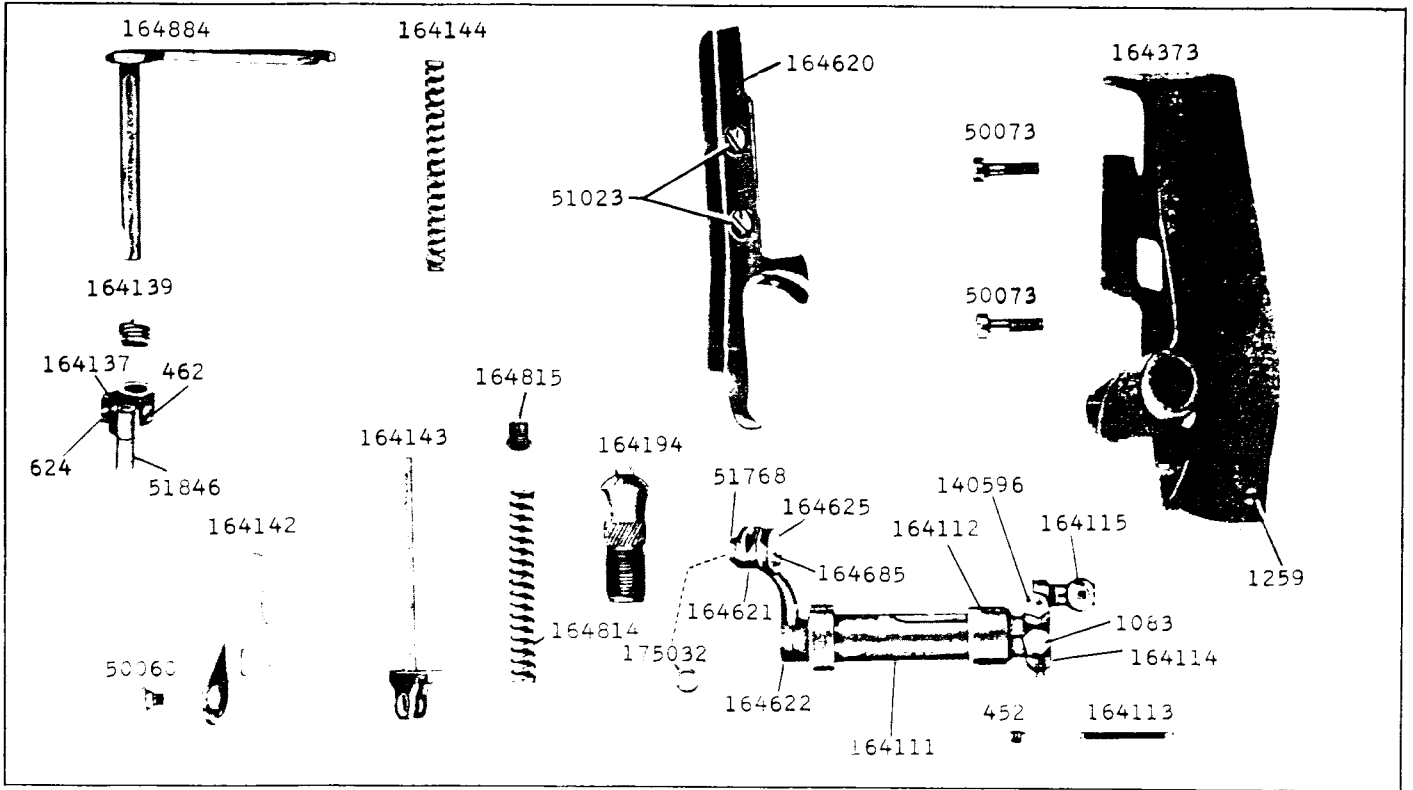

3049 - 1/4

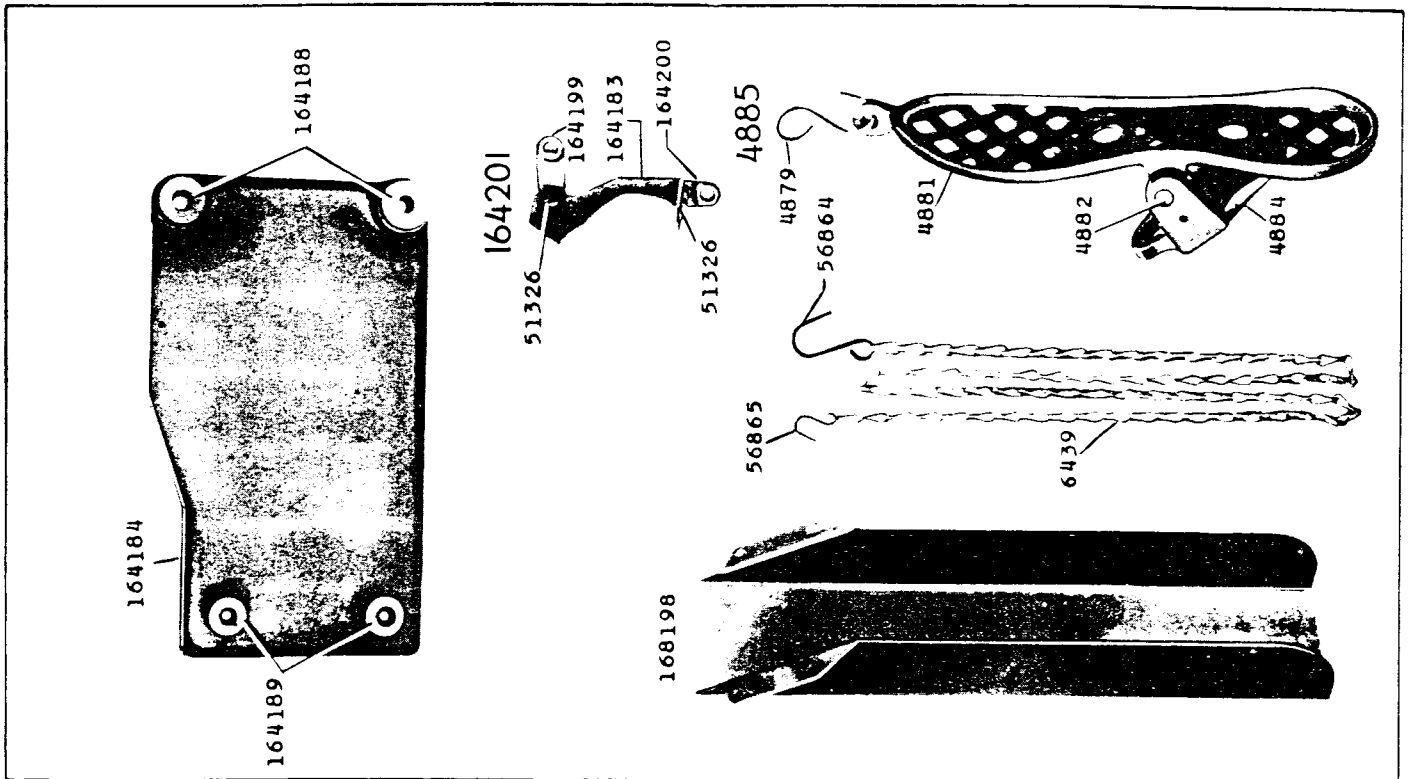

ILLUSTRATIONS

3051 - 1/2

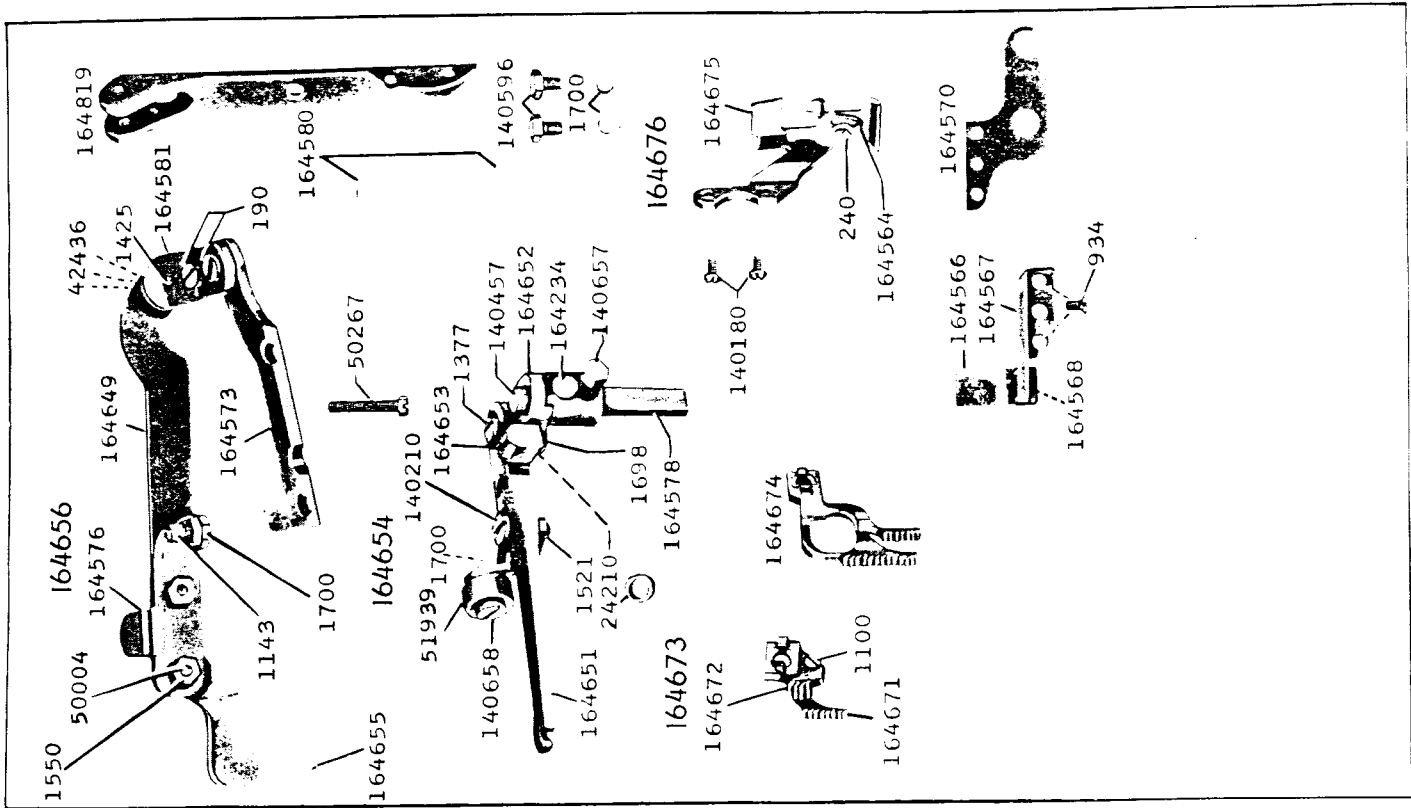

3053 - 1/3

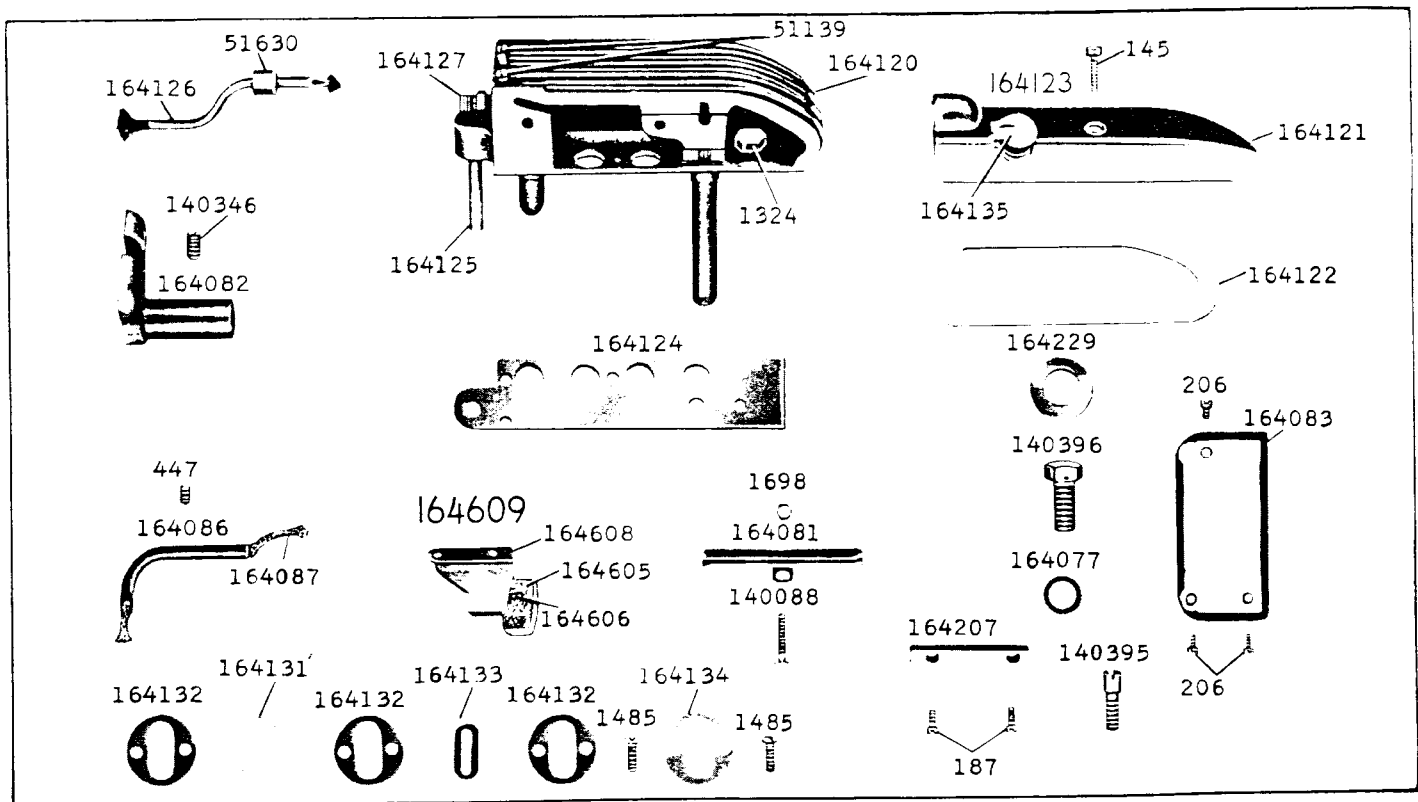

ILLUSTRATIONS

3054 - 2/3

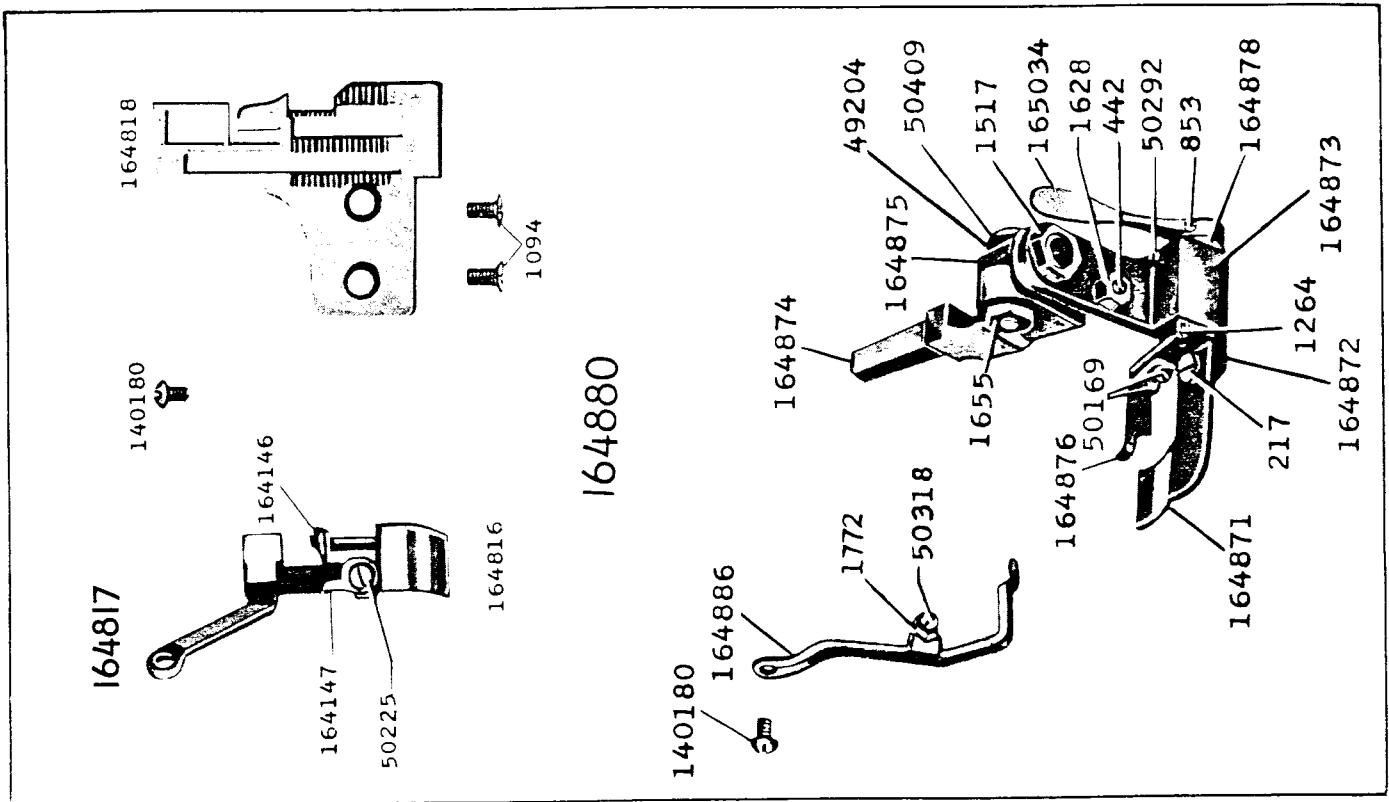

3056 - 1/3

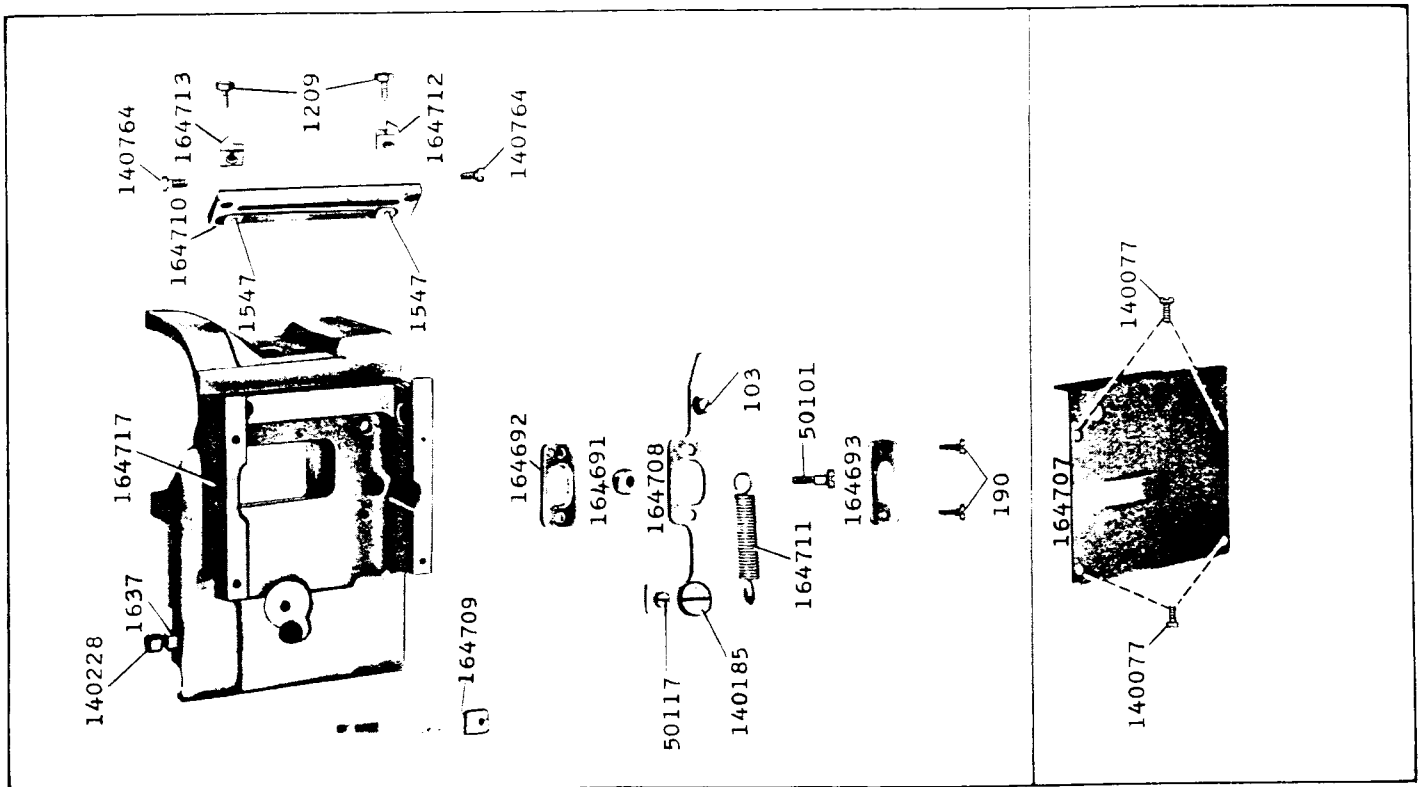

ILLUSTRATIONS

3059 - 1/3

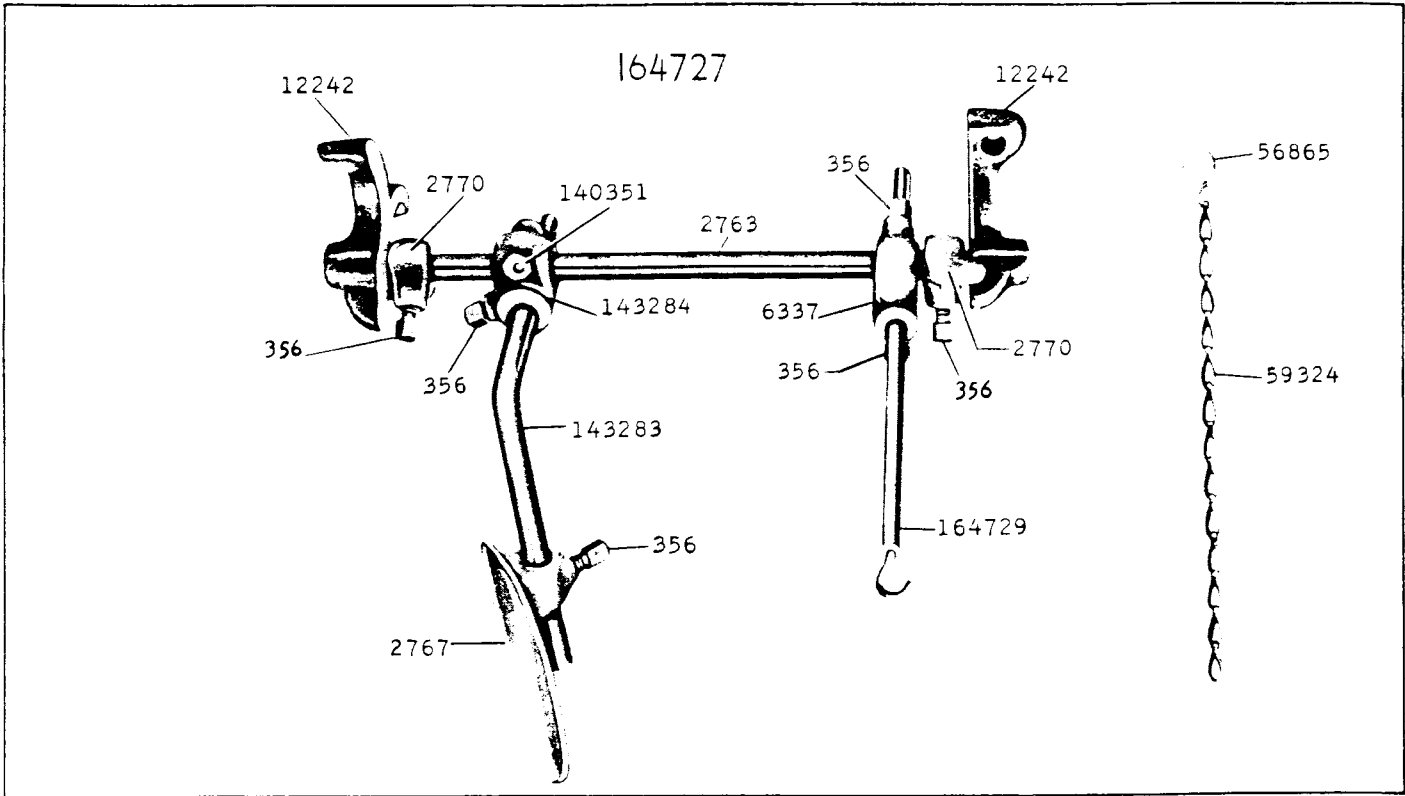

3060 - 1/6

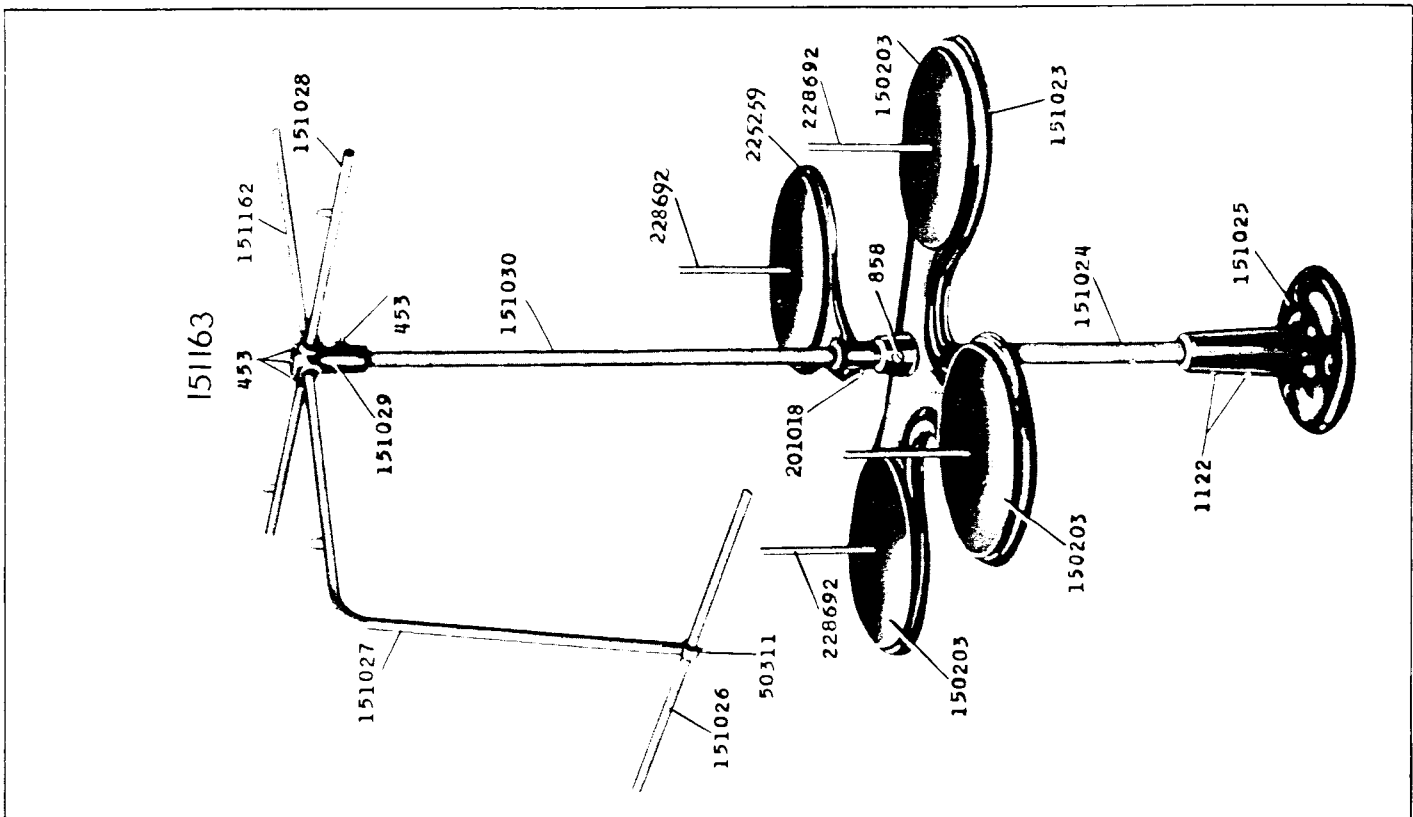

ILLUSTRATIONS

3072 - 2/3

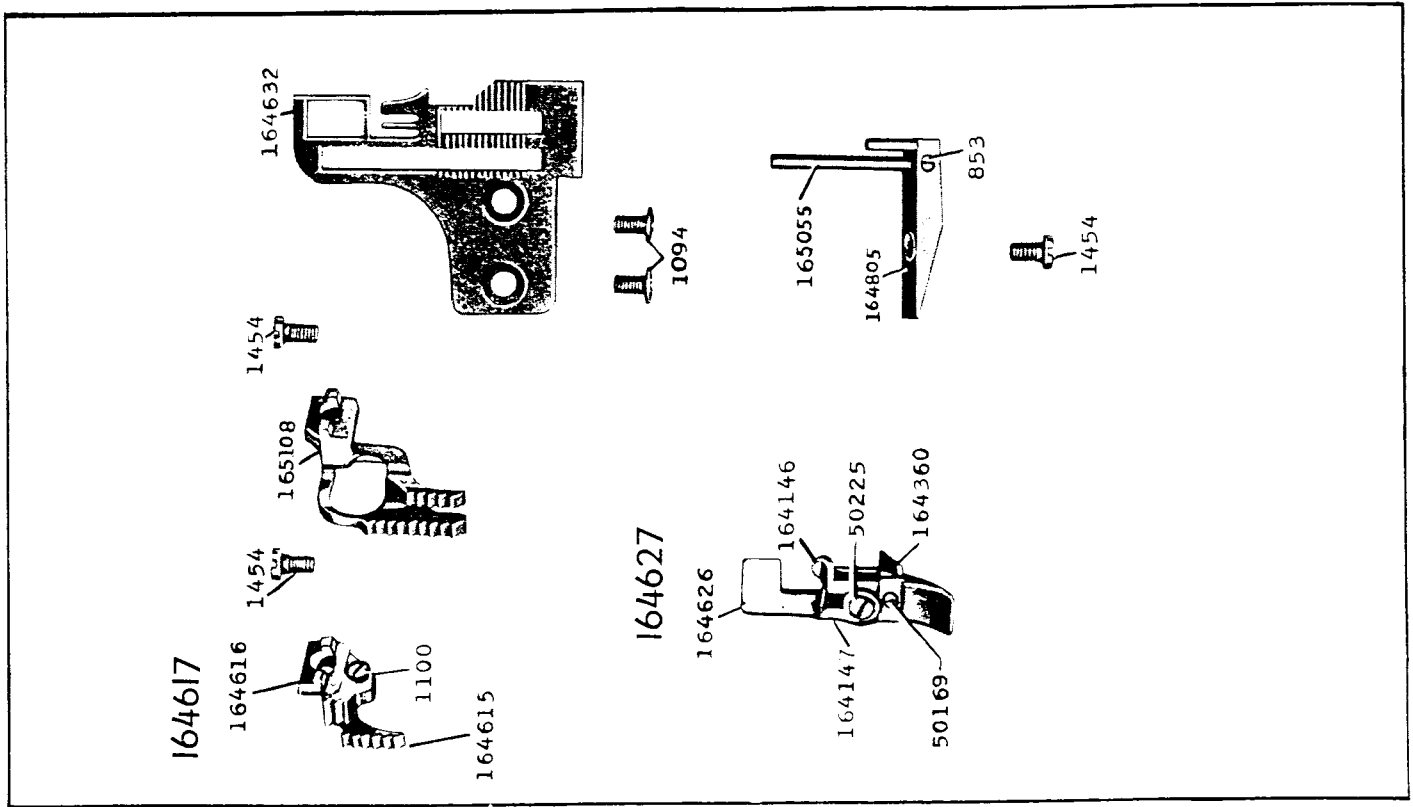

3073 - 1/2

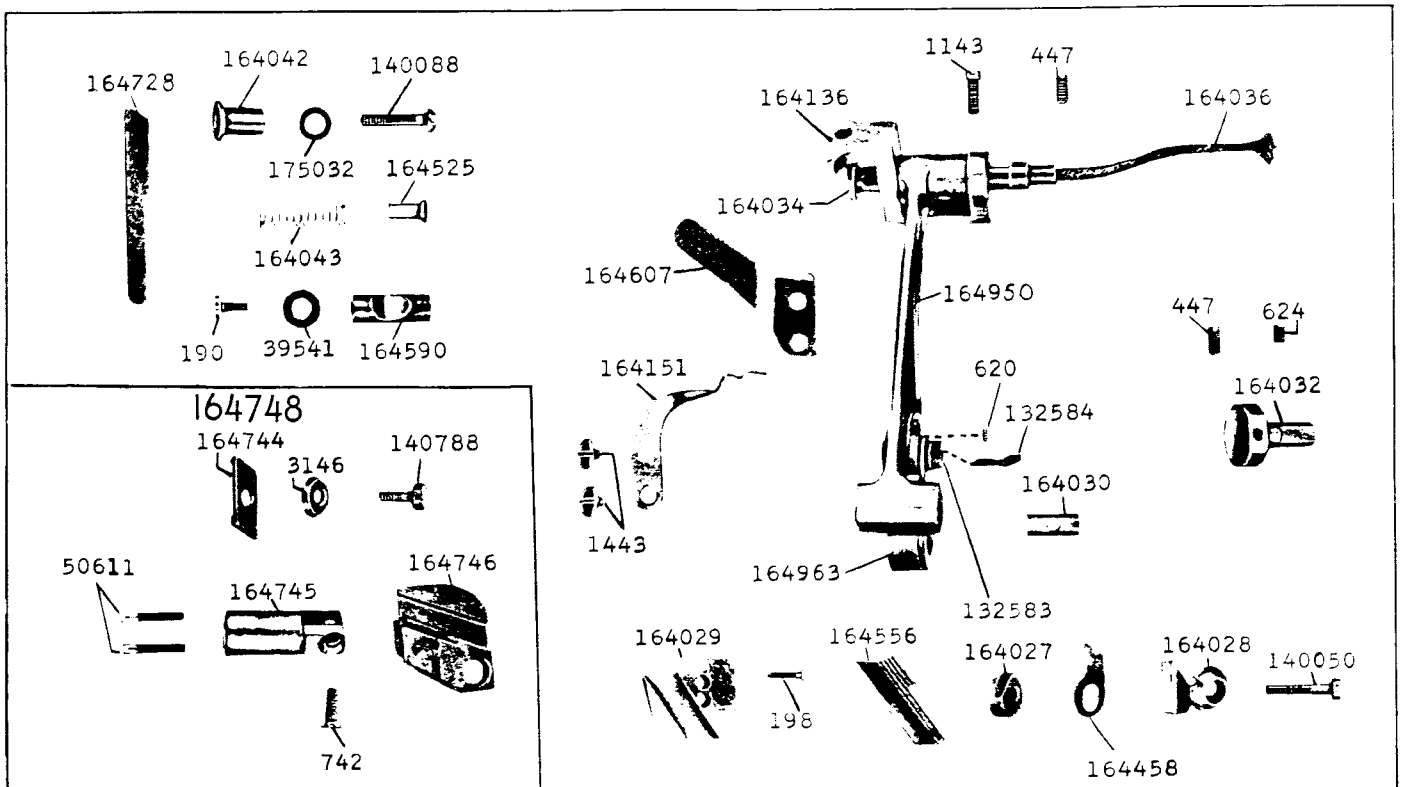

ILLUSTRATIONS

3074 - 1/2

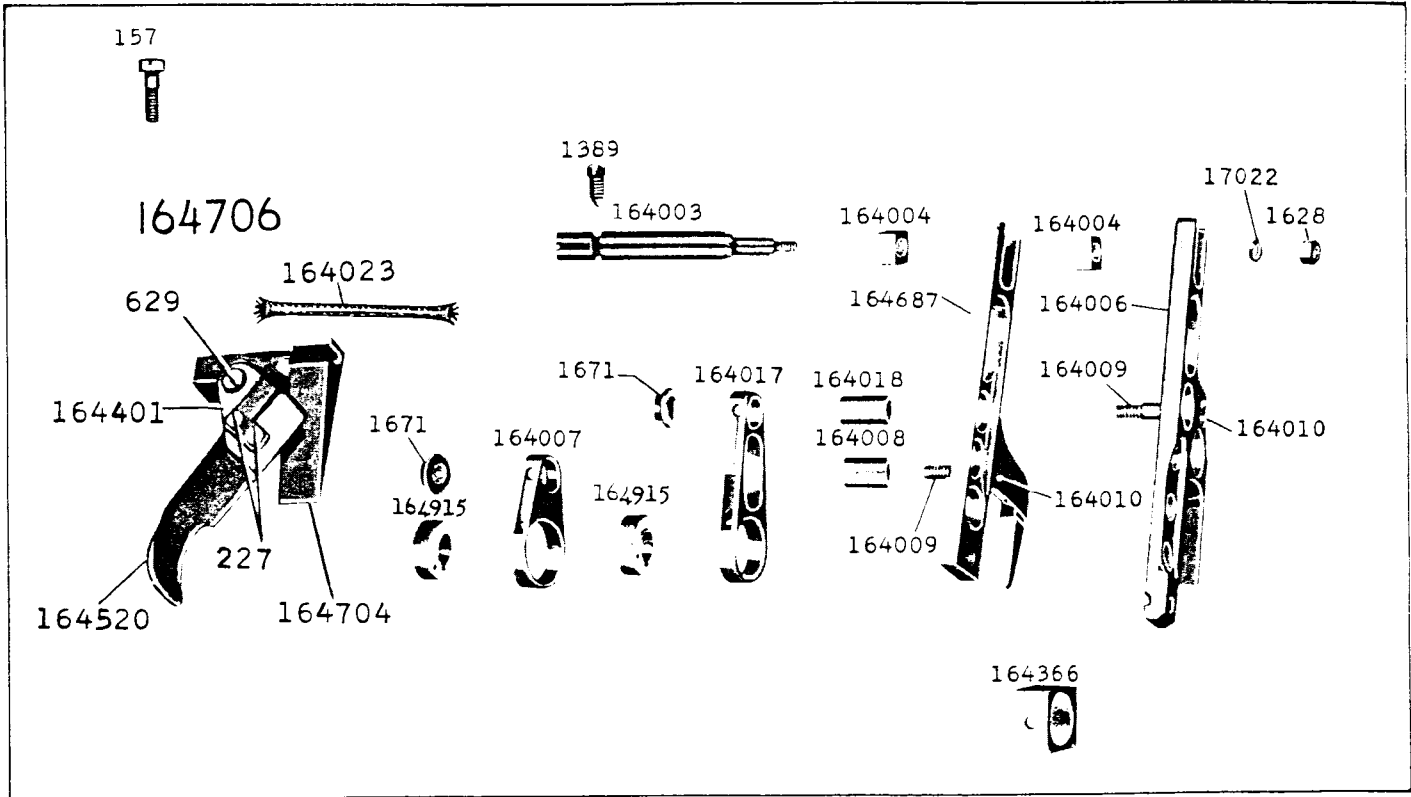

3075 - 1/2

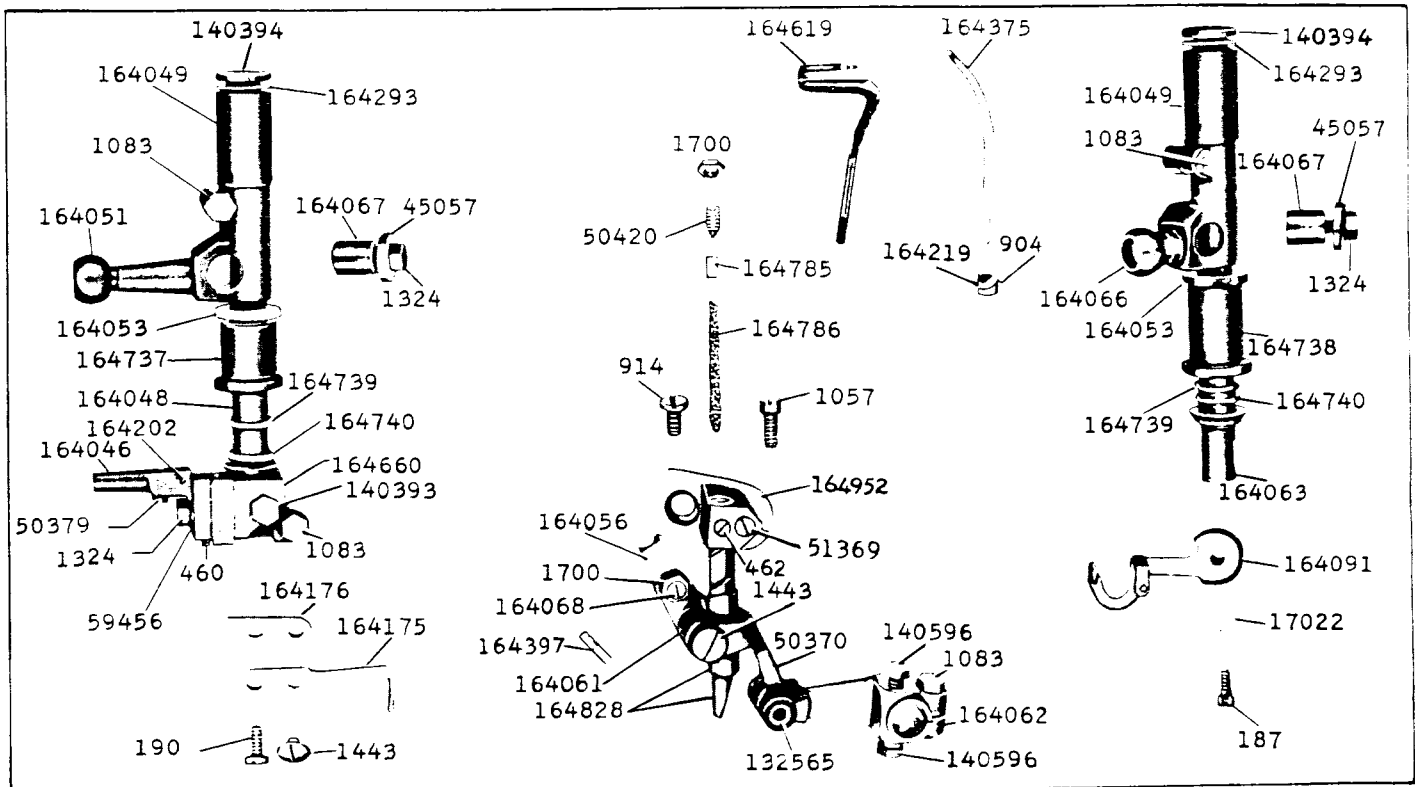

ILLUSTRATIONS

3076 - 1/3

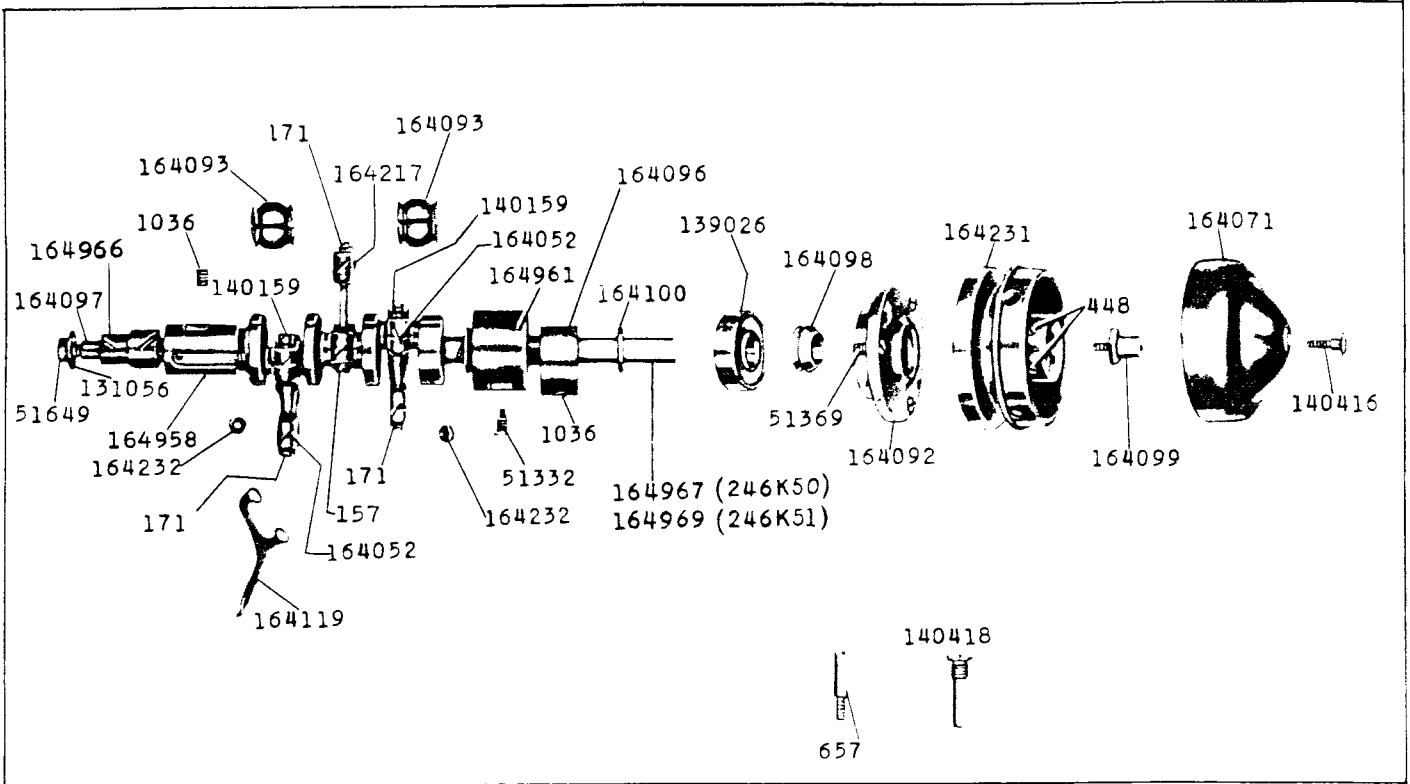

3077 - 1/2

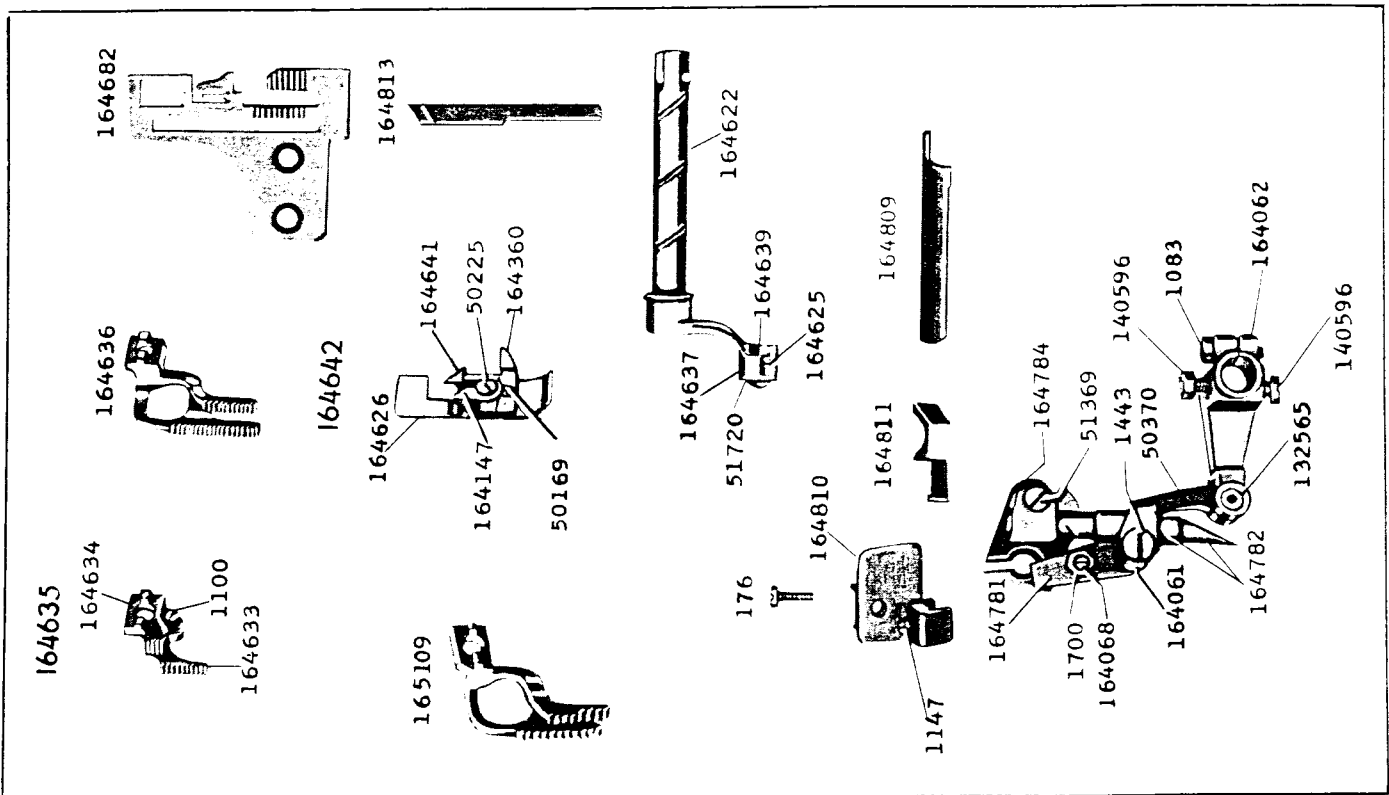

ILLUSTRATIONS

3078 - 1/2

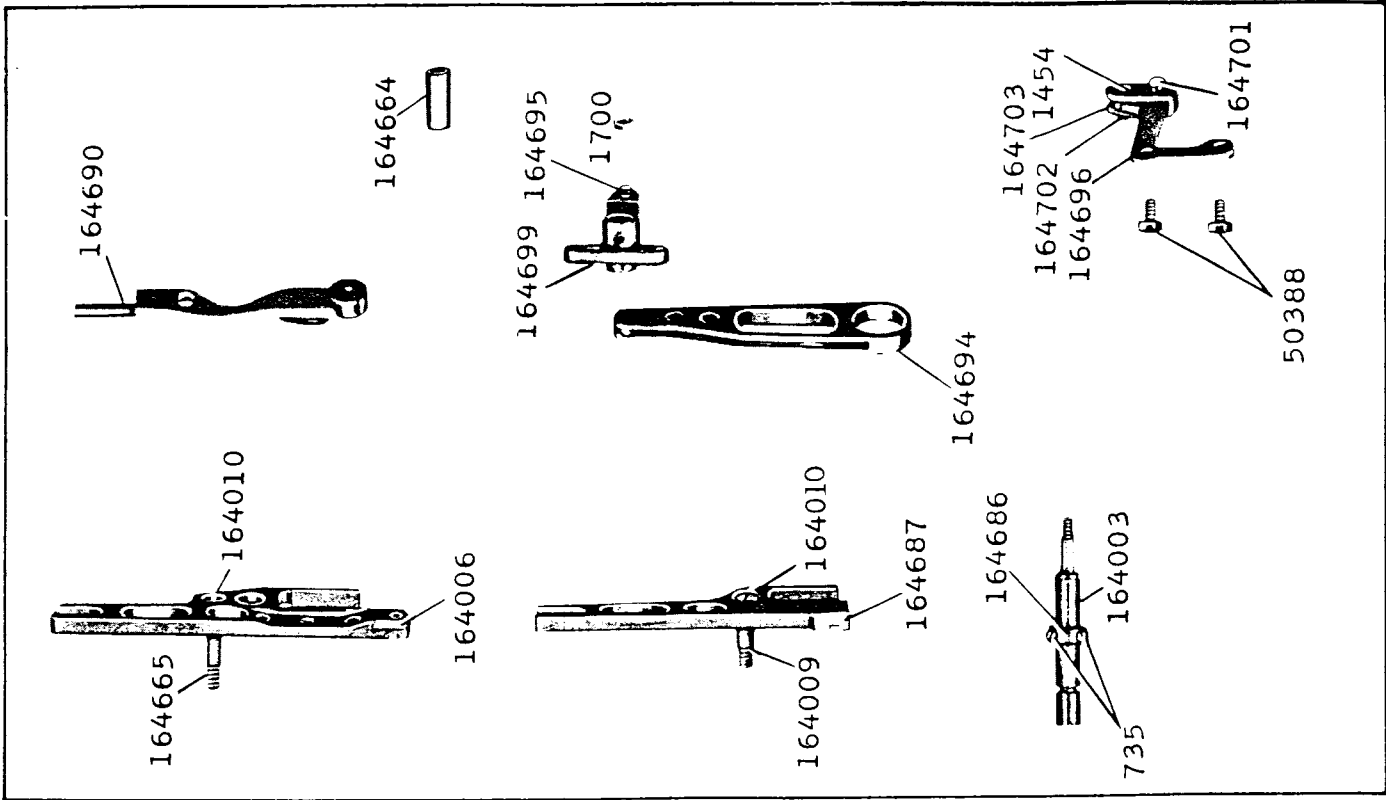

3079

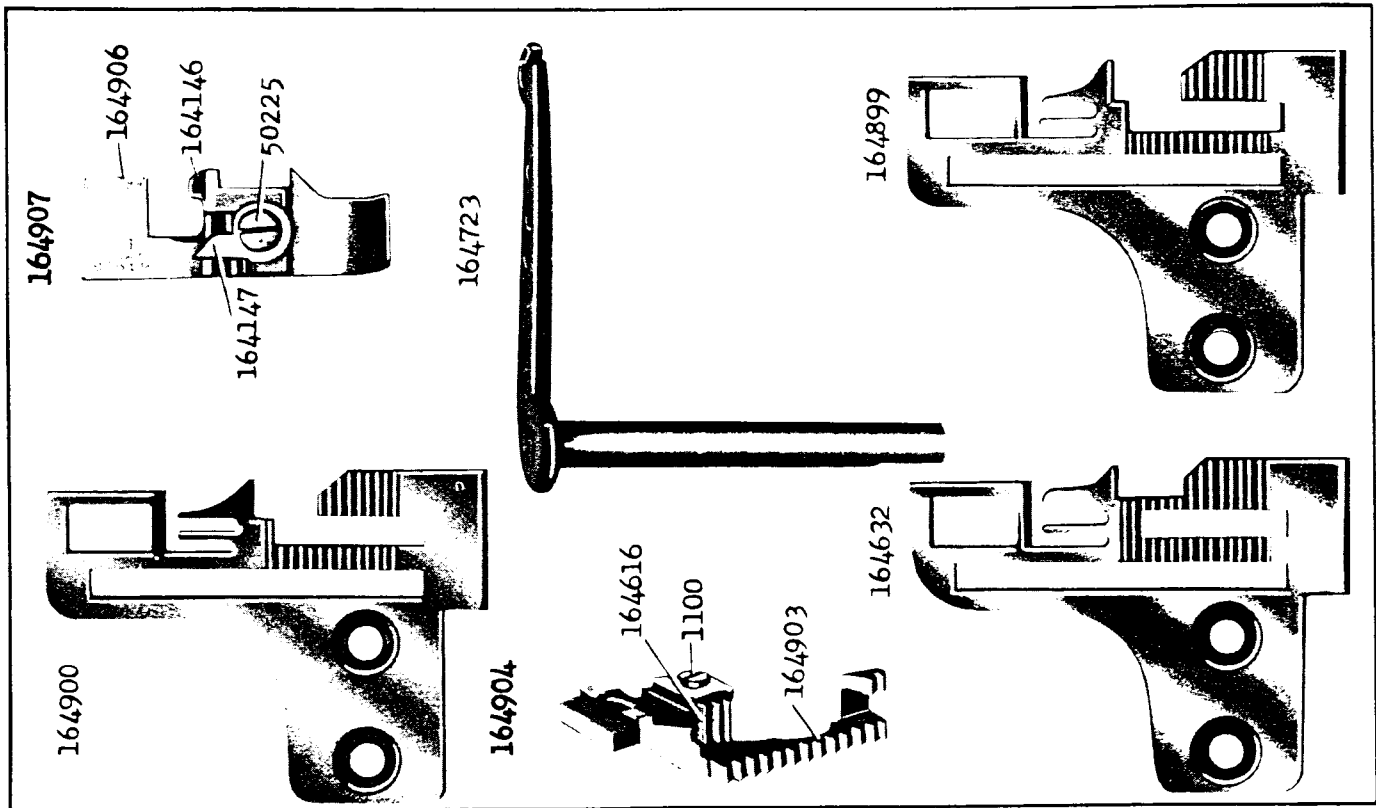

ILLUSTRATIONS

24813 - 1/3

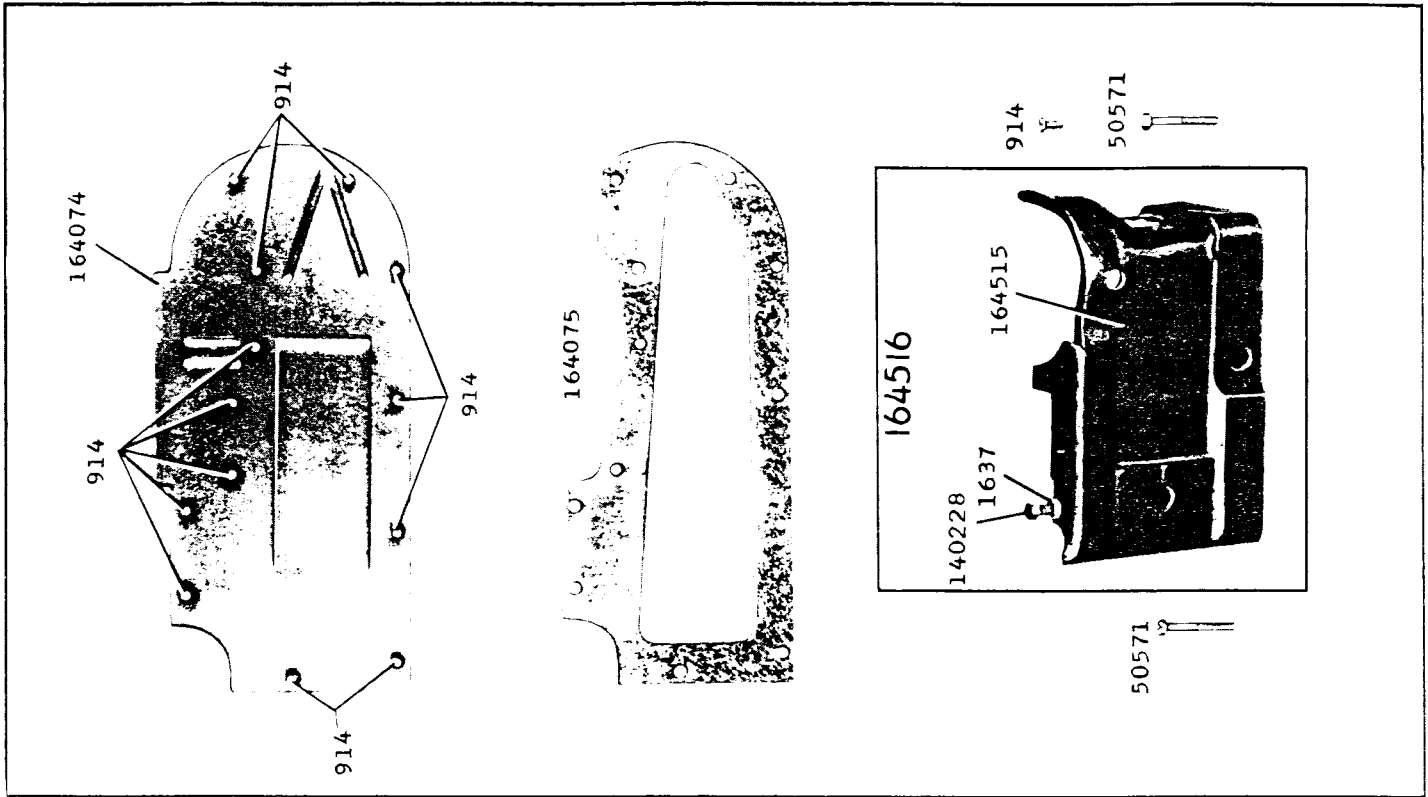

24878 - 1/2

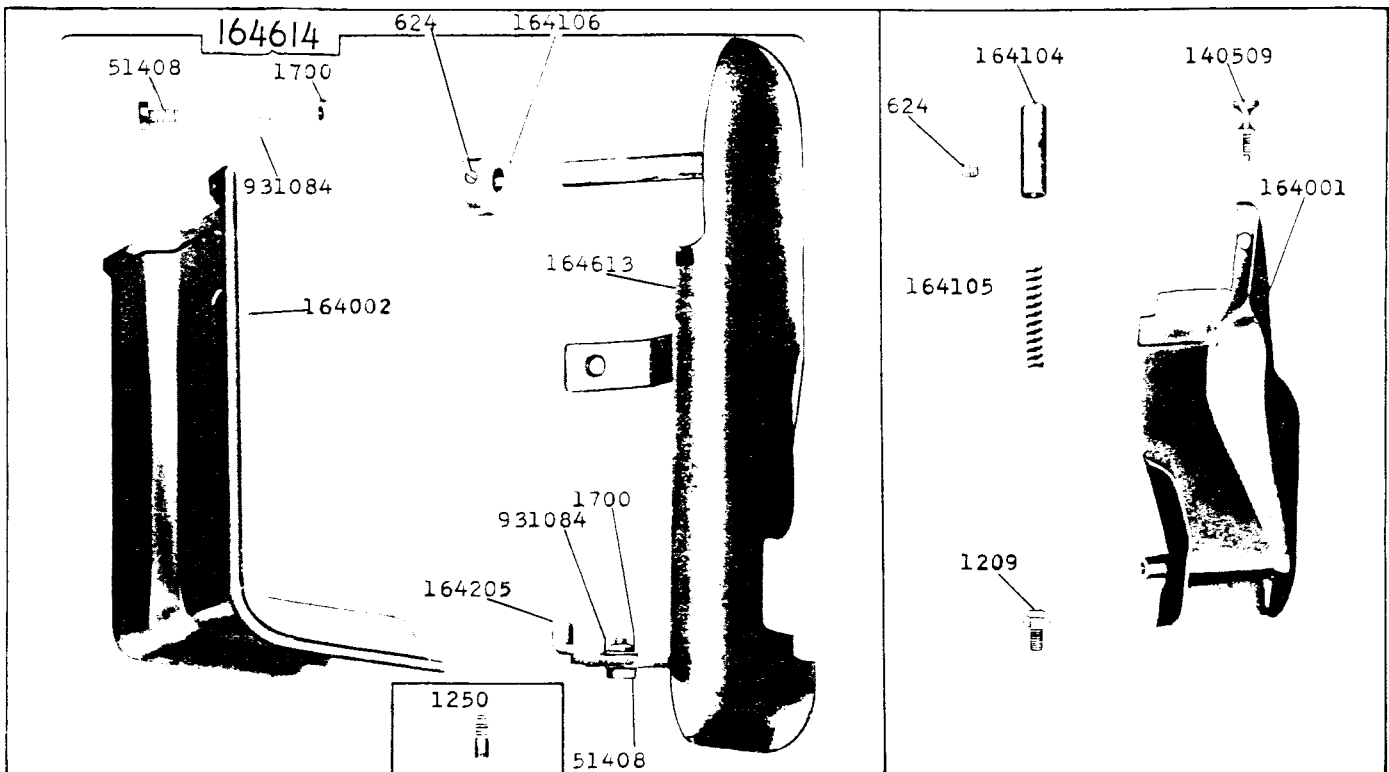

ILLUSTRATIONS

24881 - 2/3

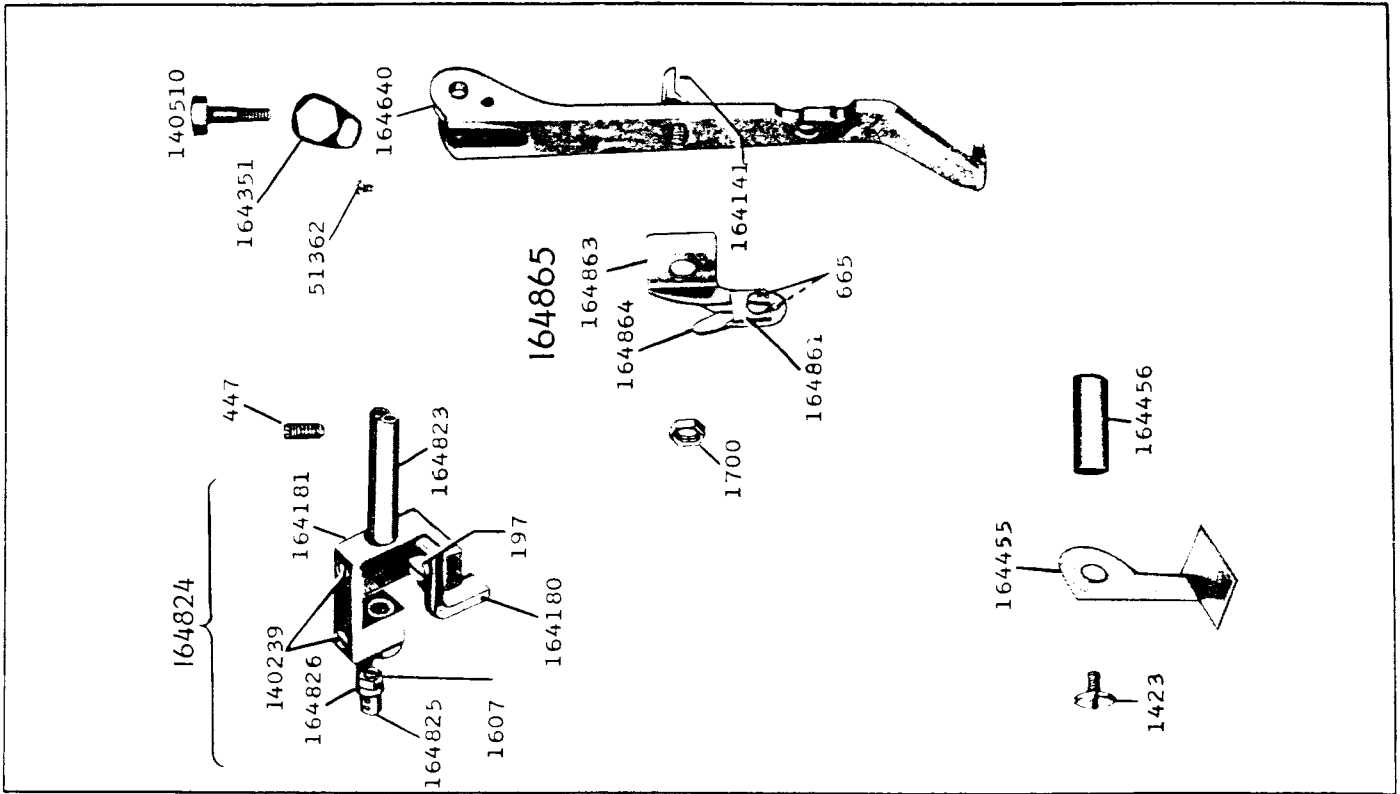

24885 - 1/3

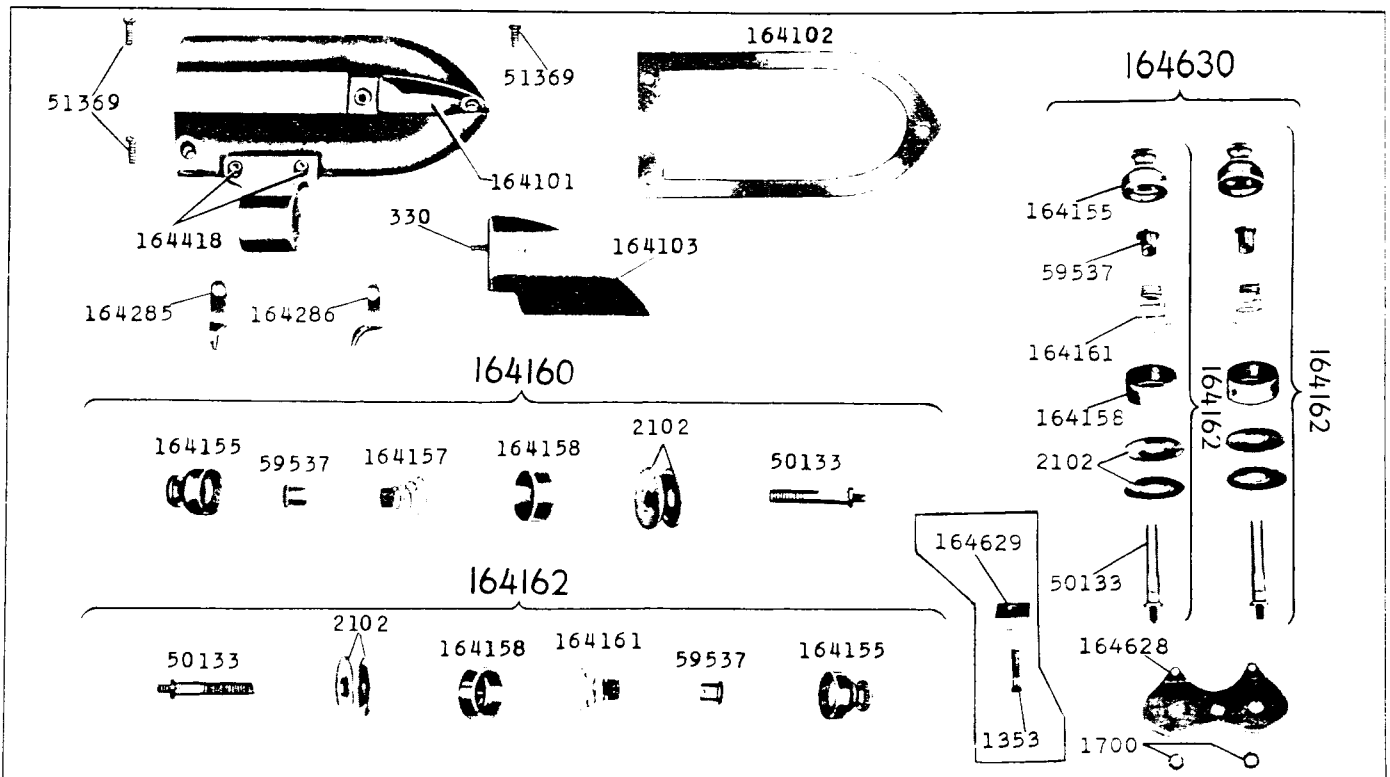

ILLUSTRATIONS

3080 - 1/2

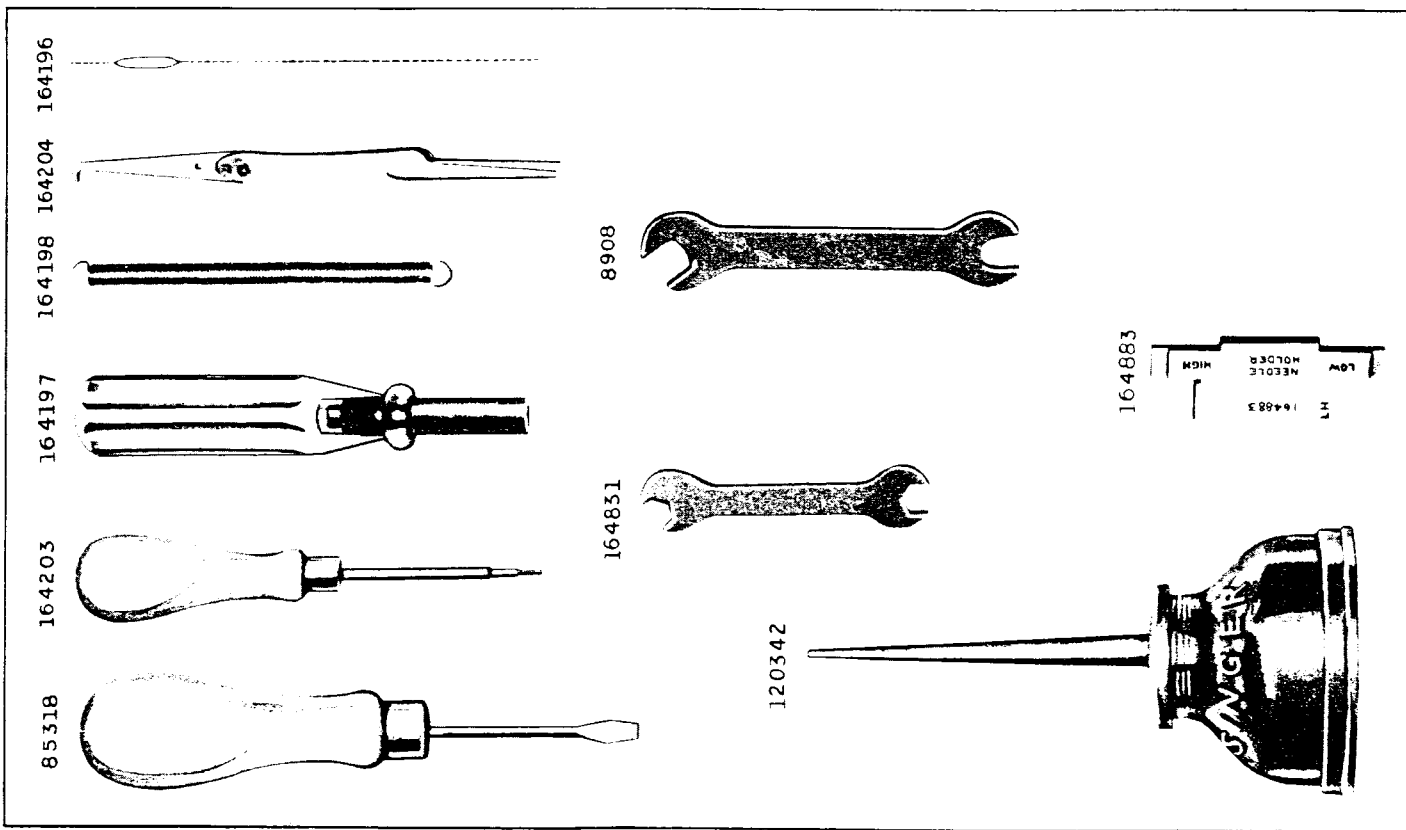

24761 - 2/3

