

SINGER
121D,121C



SERVICE MANUAL

SINGER^{*}

Sewing Machine

121D CLASS

121C CLASS

Copyright © 1976 The Singer Company
All Rights Reserved Throughout the World
*A Trademark of THE SINGER COMPANY

Form 21624 (Rev. 977)

Printed in U.S.A.

LUBRICATION

Moving parts have either permanently sealed pre-lubricated ball or needle bearings or oil impregnated bushings which require no manual lubrication. The following exceptions are:

HOOK

An oil reservoir supplies oil to the sewing hook race and is filled through the oil cup as shown, with Singer Type "C" oil, until the word "MAX" is seen in the indicator window.

Check oil level at indicator window daily before starting machine. As oil level decreases, red arrow will appear (Fig. A).

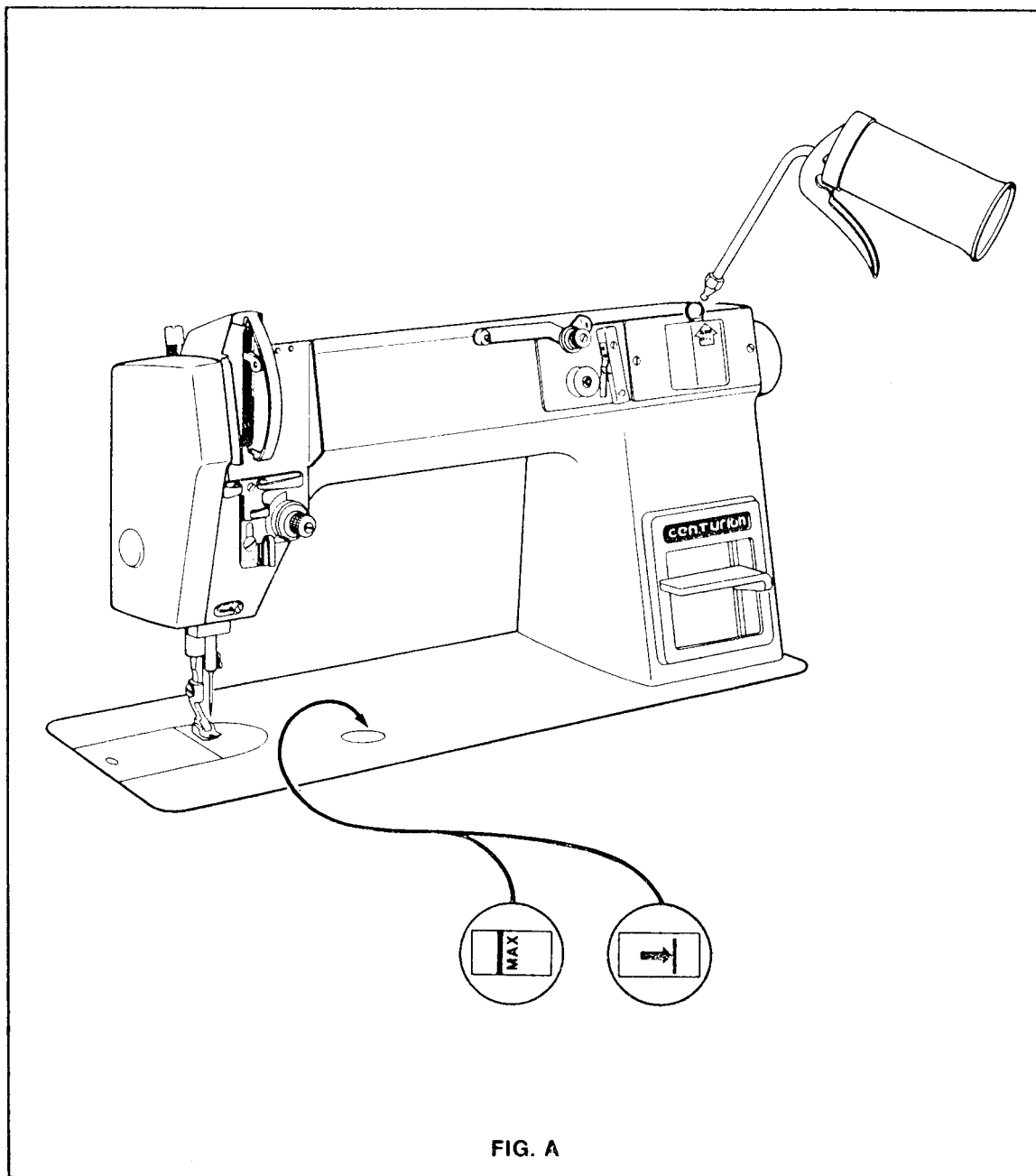
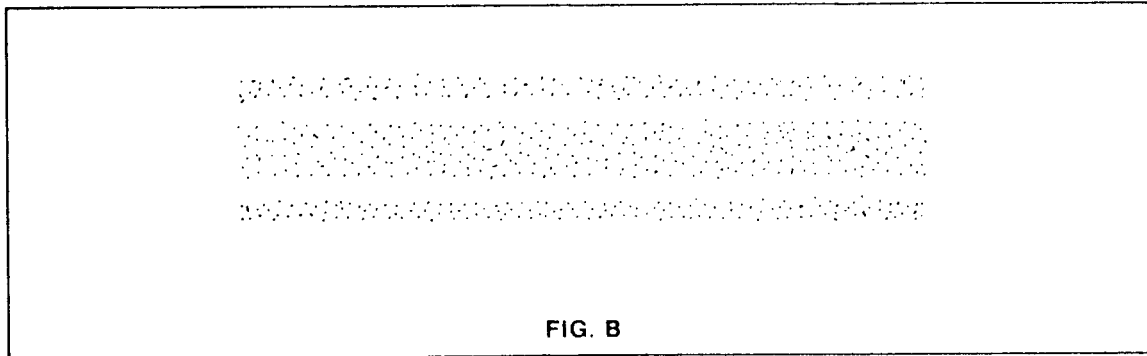

FIG. A

TO TEST HOOK LUBRICATION

Thread machine and sew 3 yards of scrap material. Pay no attention to stitch quality or amount of oil at this time. Remove material and bed slide. Run machine approximately one minute to establish a uniform oil flow. Without stopping machine, hold a piece of paper in place under hook for 10 seconds. Remove paper and compare oil pattern with Fig. B for proper oil flow.



If there is no trace of oil or an excess, adjustment should be made with the oil metering screw. In order to gain access to oil metering screw, the hook should be in position as shown in Fig. C. Turn oil metering screw clockwise for more oil and counterclockwise for less (Fig. D). Normal setting is made by turning the metering screw all the way in and then backing the screw 3 or 4 turns out. More or less turns may be required depending on the operation being performed.

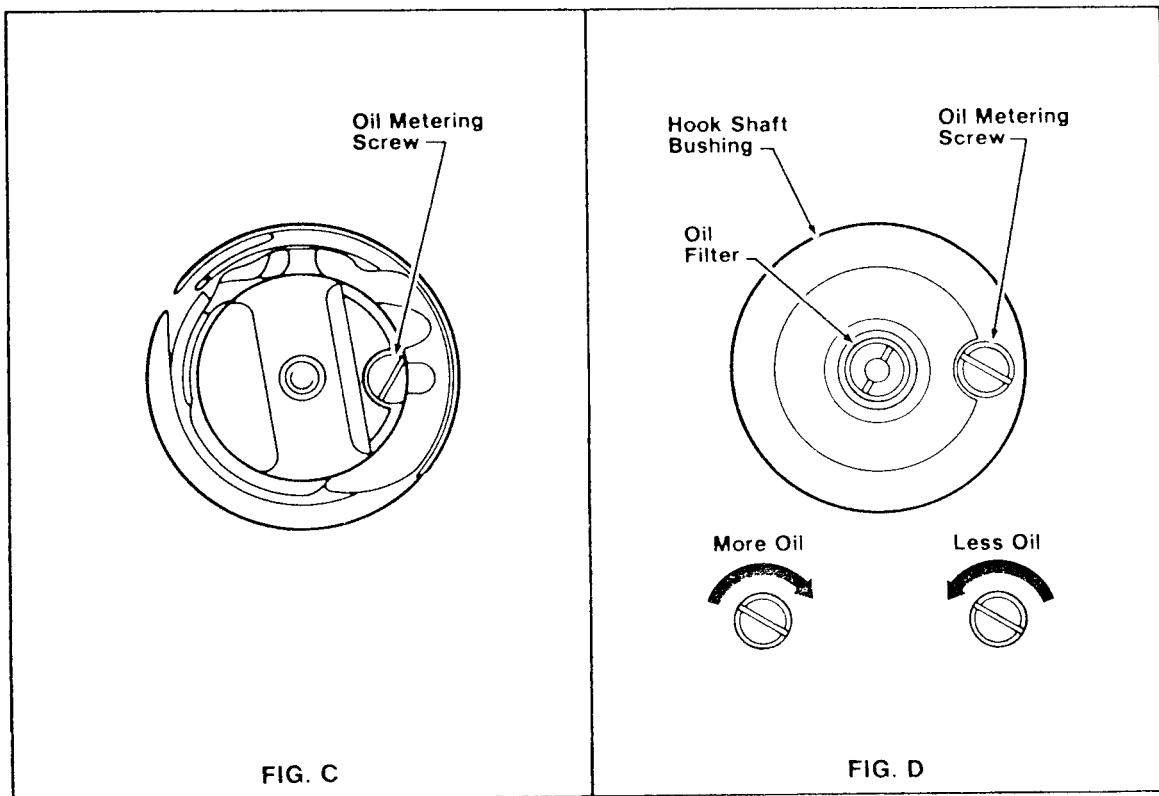

If oil flow is not satisfactory, remove hook assembly and oil filter. Check filter. Oil wick should be replaced whenever it has become clogged with lint or dirt. An excess of oil sometimes indicates that the filter wick has become detached from the screw or the screw is not securely tightened. Inspect all oil passages to see they have not become clogged.

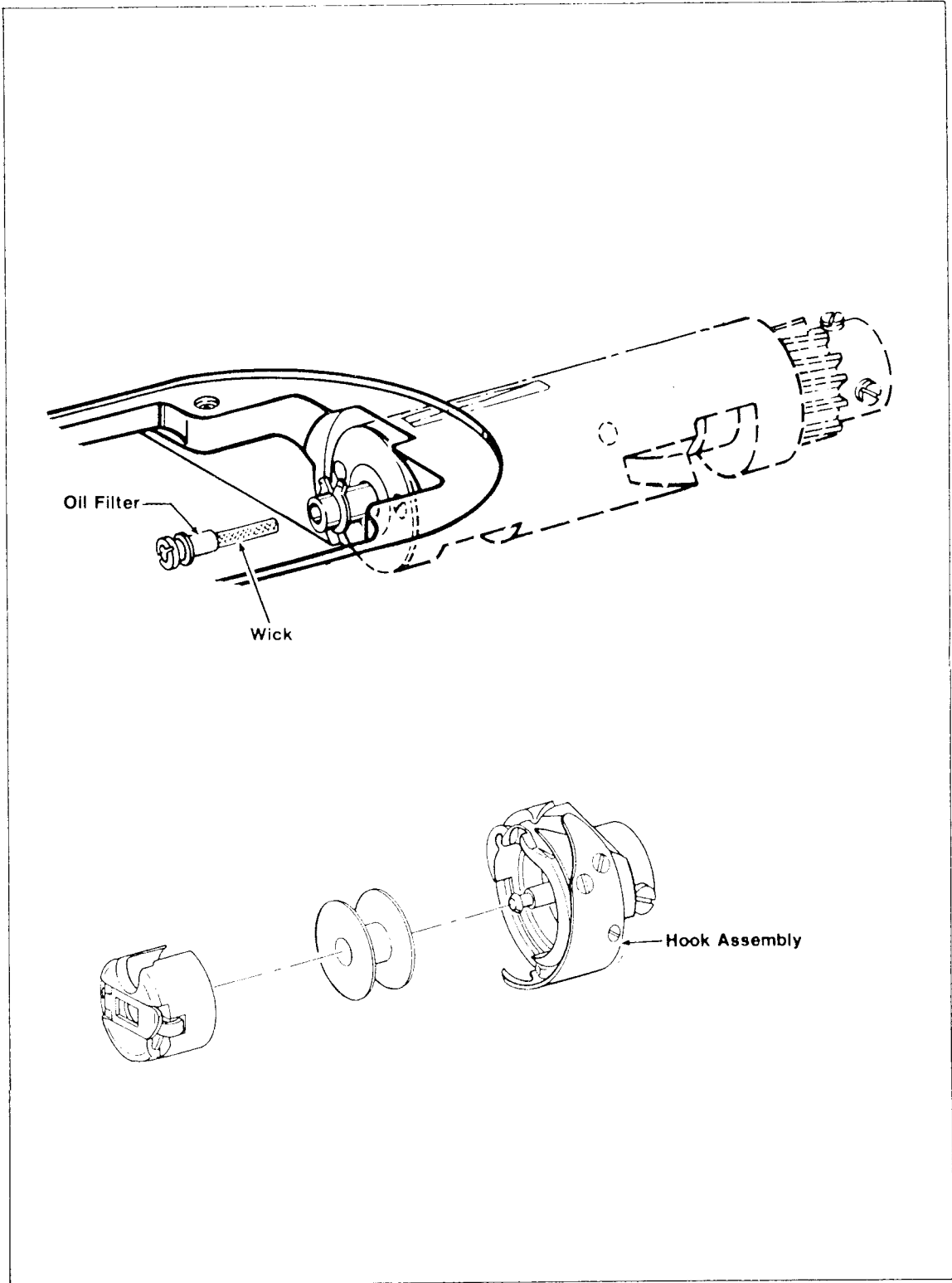

MACHINE THREADING

1. Move take-up eyelet to its highest point.
2. Lead thread from thread stand through thread post atop machine arm
3. Through 3 eyelets of thread guard
4. Units with U.T.T., through pretensioner
5. Down through thread retainer
6. Into and around tension assembly
7. Over check spring and under slack thread regulator
8. Up to and through thread retainer and take-up eyelet
9. Down through thread retainers (2)
10. Through needle bar thread guide
11. Through needle eye from left to right

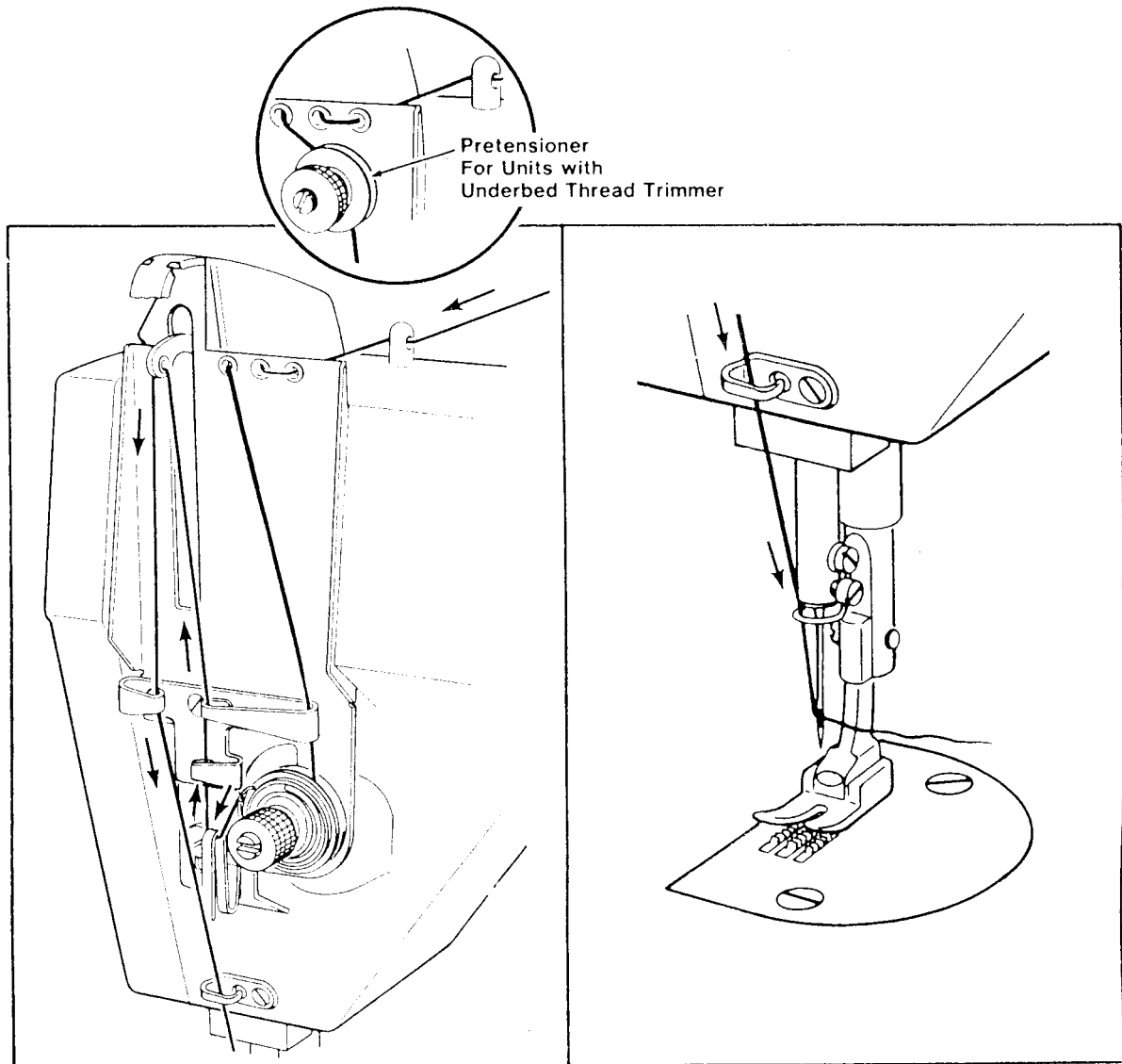

STITCH LENGTH

The stitch length can be regulated while the machine is in operation. To obtain the desired stitch length in forward feed, turn regulating thumb screw on oil pan "in" (counterclockwise) for less stitches per inch, and "out" (clockwise) for more (Fig. A).

To adjust the stitch length for reverse feed, it is necessary that the reverse stopping block be properly positioned. This is done by loosening the lock screw in the stopping block and sliding the slide block up or down to the desired stitch length. The locking screw must then be retightened (Fig. B).

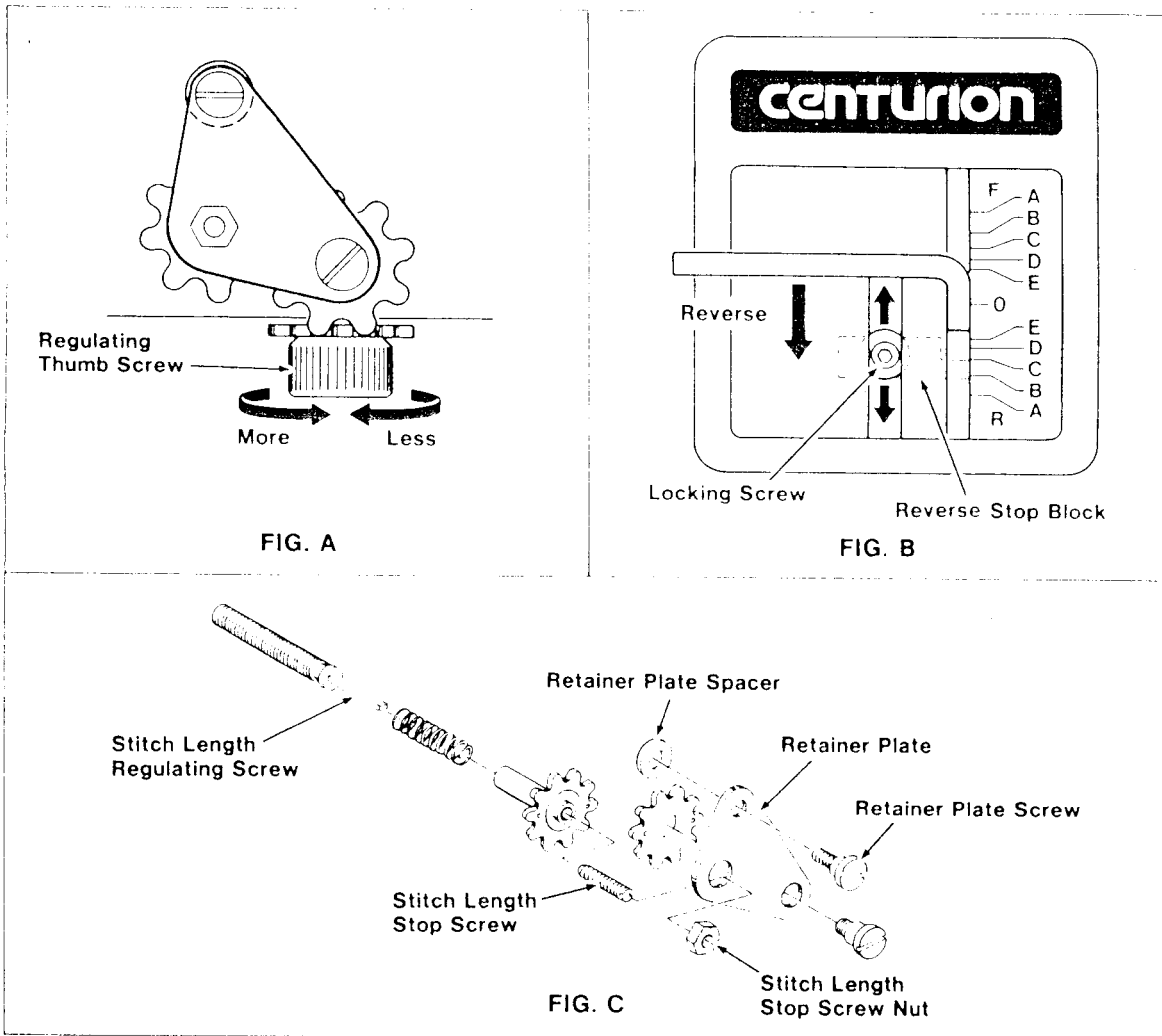

PREVENTING UNAUTHORIZED CHANGES IN STITCH LENGTH

To prevent unauthorized changes in stitch length remove the retainer plate screw and take out the retainer plate spacer.

Replace and tighten the retainer plate screw (without spacer) which will lock the retainer plate against the stitch regulating gears (Fig. C).

ADJUSTABLE STITCH LENGTH STOP

An adjustable stitch length stop is provided to prevent the machine from making stitches longer than pre-determined maximum. To adjust the stop, set the machine to desired stitch length as previously instructed and turn stop screw until it bottoms against the stitch length regulating screw. Lock stop screw in place with stop screw nut (Fig. C).

Stitch length setting should NEVER EXCEED capacity of fittings in use.

PRESSER FOOT PRESSURE

The pressure on the material should be as light as possible while still sufficient to ensure correct feeding. There are two regulating screws that control the presser foot pressure. One atop the arm and one at the rear of the machine. The one atop the arm is the major control, normally adjusted prior to long production runs or new applications. For day-by-day casual adjustments, the regulating screw at the rear is used, screwing in for less pressure and unscrewing for more pressure. When this rear screw is unscrewed all the way out, it disengages; only then can the top screw be applied, and it serves as the sole control until the rear screw is again turned inward (Fig. A).

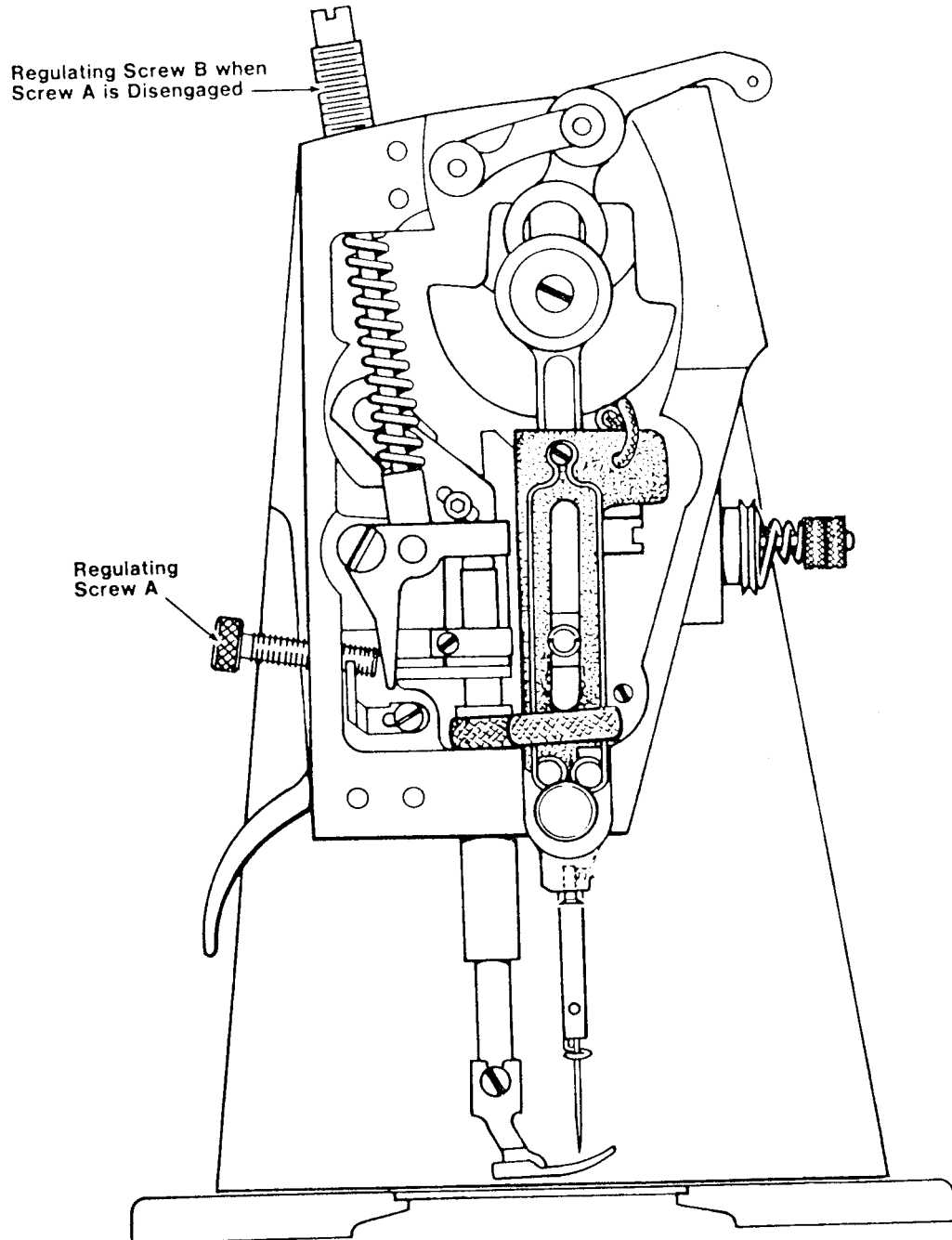
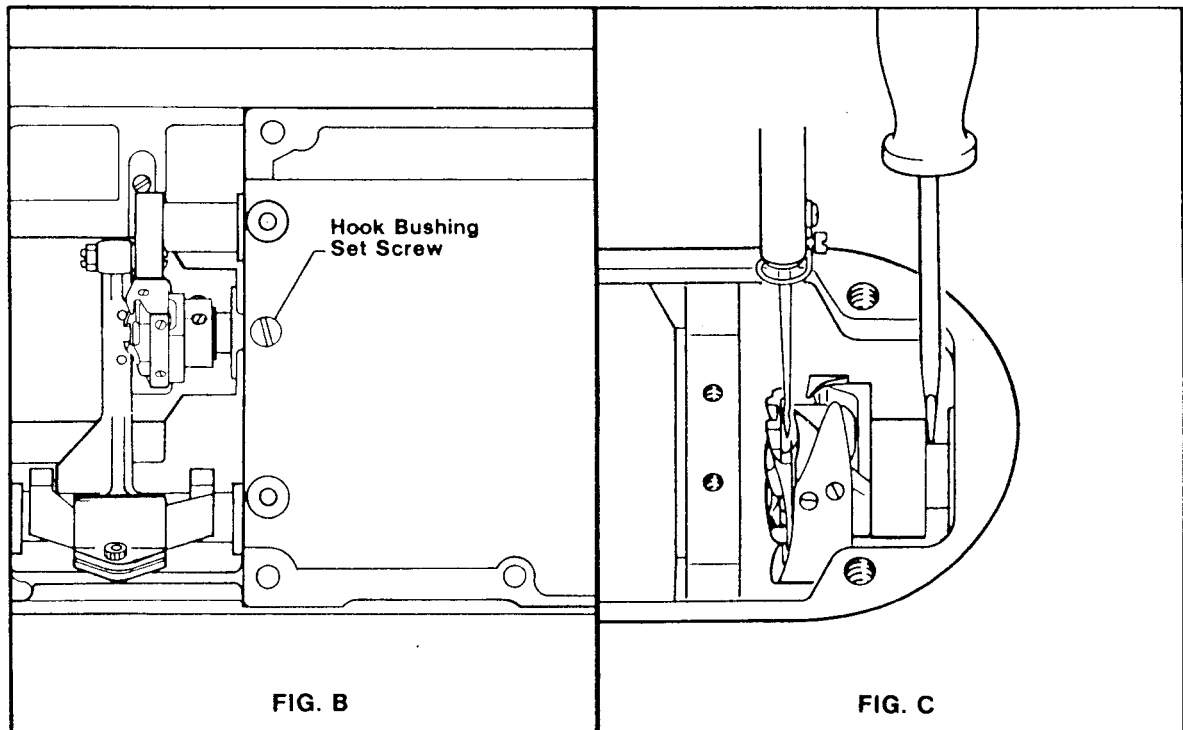
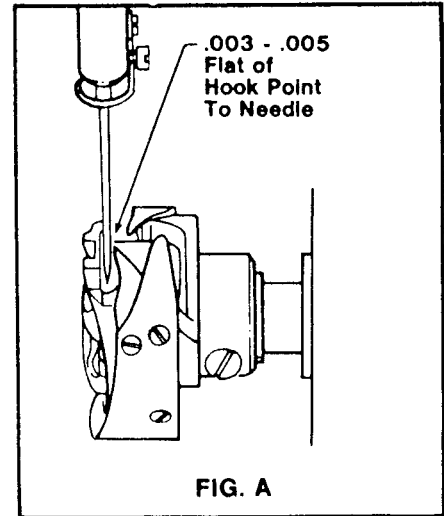

FIG. A

HOOK TIMING

Proper clearance between needle and hook point, requires that the point of the hook should pass the needle as closely as possible without striking or deflecting it. There should be .003" - .005" clearance between the two (Fig. A).

To adjust clearance, loosen bushing set screw (Fig. B). With screwdriver placed as shown move entire hook and bushing (Fig. C). Tighten bushing set screw.



Insure that the needle guard prevents the needle from contacting the hook point at any time. If large needles are to be used it may be necessary to string the needle guard back to allow hook point closer to needle (Fig. D).

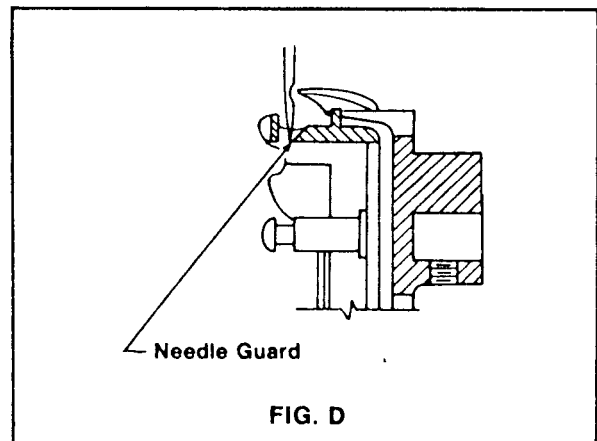

HOOK TIMING CONT'D

Reset position finger so there is .018" - .022" thread clearance between finger and basket (Fig. E).

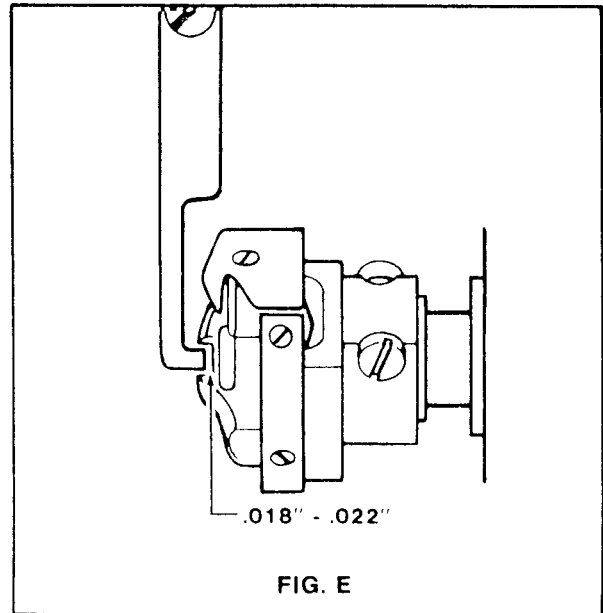

For 200 Variety Machines (.085" Loop Rise)

Loosen hook set screws. Turn hand wheel in direction of rotation until needle bar is on the rise stroke and the lowest mark is aligned with the needle bar height indicator. Set hook point to the centerline of the needle (Fig. F). Tighten hook set screws.

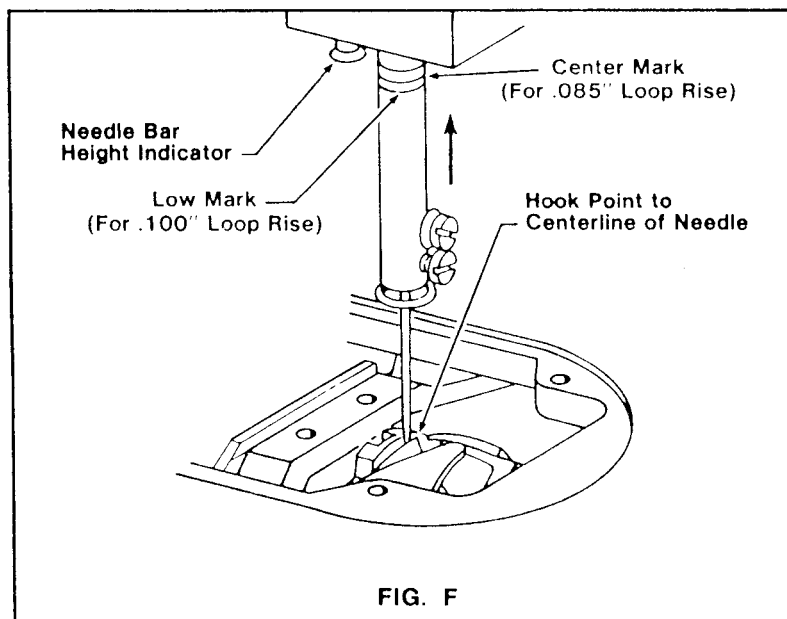

For 300 Variety Machines (.100" Loop Rise)

Loosen hook set screws. Turn hand wheel in direction of rotation until needle bar is on the rise stroke and the center mark is aligned with the needle bar height indicator. Set hook point to the centerline of the needle (Fig. F). Tighten hook set screws.

TIMING FEED LIFTING SHAFT TO ARM SHAFT

Manually rotate arm shaft until timing mark on counterbalance aligns with timing mark on take-up stud connecting link (Fig. A).

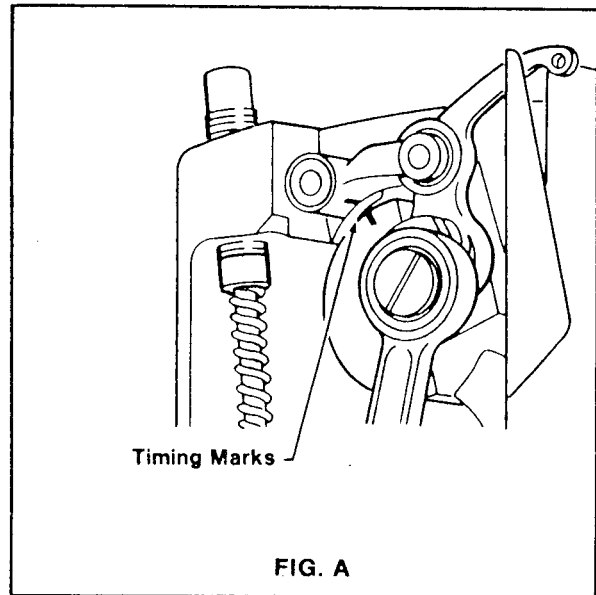

Loosen bed shaft timing belt pulley set screws (Fig. B). Hold pulley stationary and rotate bed shaft until timing line at feed bar end of shaft aligns with timing mark on casting (Fig. C). Timing marks alignment in Fig. A and Fig. C must occur simultaneously. Tighten pulley set screws.

NOTE: There are two timing marks on the bed shaft. The long timing mark is for drop feed machines and the short timing mark is for compound feed machines.

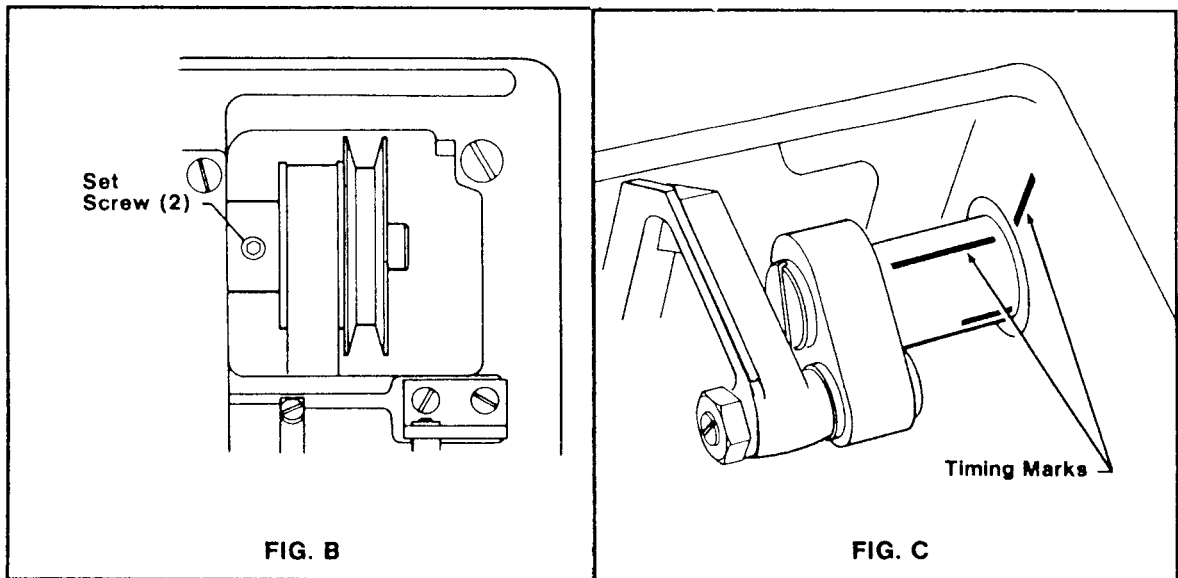

FEED DOG SETTING

Centrally locate feed dog in throat plate slots. Feed dog must not make contact with throat plate, as noted. Align by loosening feed dog screws. Then retighten screws Fig. A.

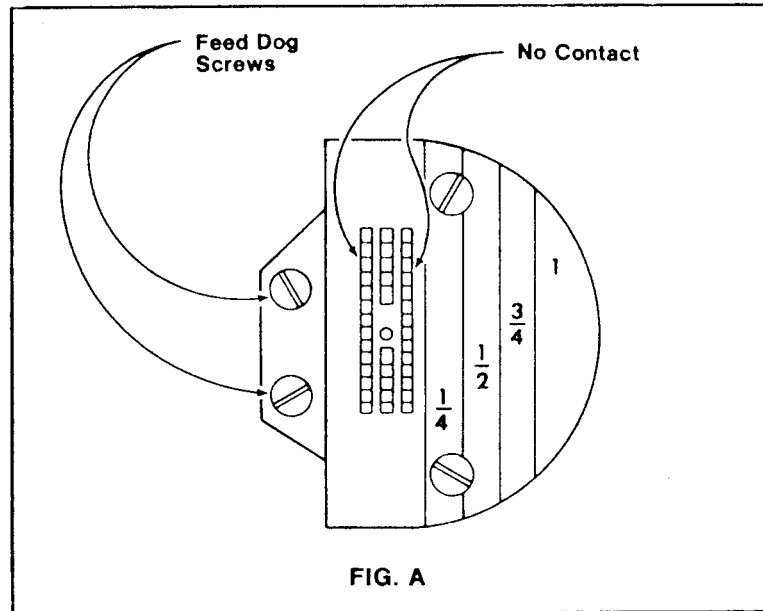

LATERAL SETTING: Loosen feed bar carrier pinch screw (Fig. B). Shift feed bar as required to locate feed dog in throat plate slots as shown above. Ensure that feed bar does not contact position finger (not shown). Tighten pinch screw and check axial play at pendant link. Adjust feed lifting shaft left or right to minimize play.

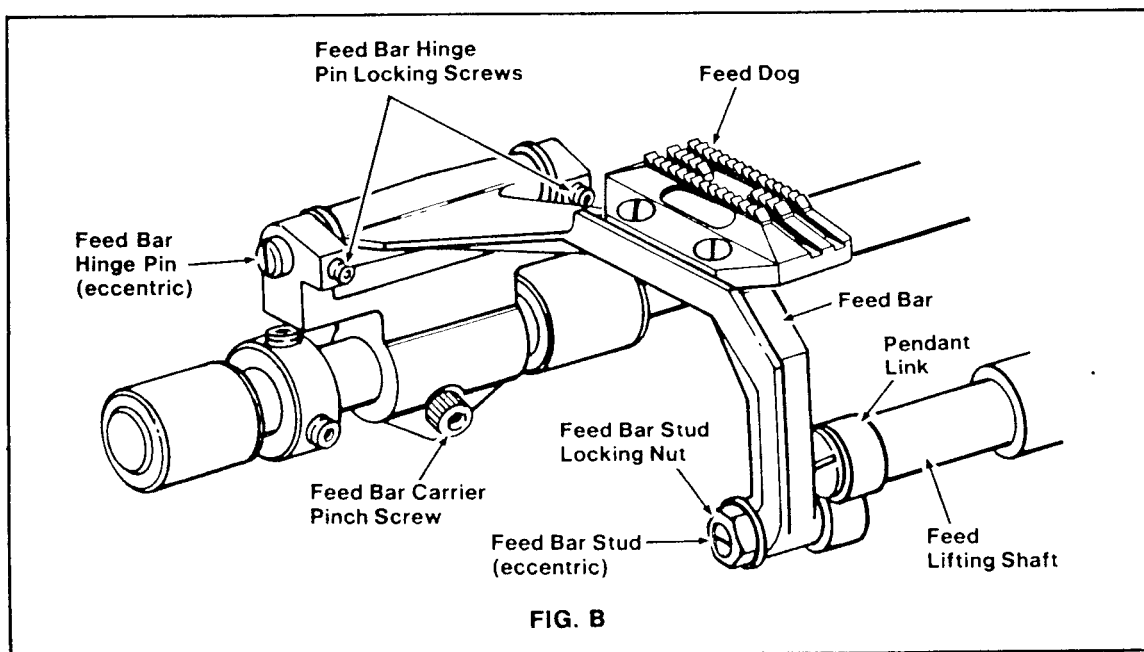

LENGTHWISE SETTING: Adjust stitch length to longest stitch and loosen feed bar carrier pinch screw. Position so that feed dog does not contact either end of slots in throat plate.

HEIGHT SETTING: Loosen feed bar hinge pin locking screws (Fig. B), and turn eccentric feed bar hinge pin. Visually adjust to bring feed dog at maximum height above throat plate and tighten both hinge pin locking screws. This will locate the slot shown in a vertical position (Fig. 1).

Loosen feed bar stud locking nut (Fig. B), and turn eccentric stud several times. You will note that the feed bar will rock back and forth. Visually position feed bar rock motion towards the operator with slot in vertical position (Fig. 1), and tighten locking nut.

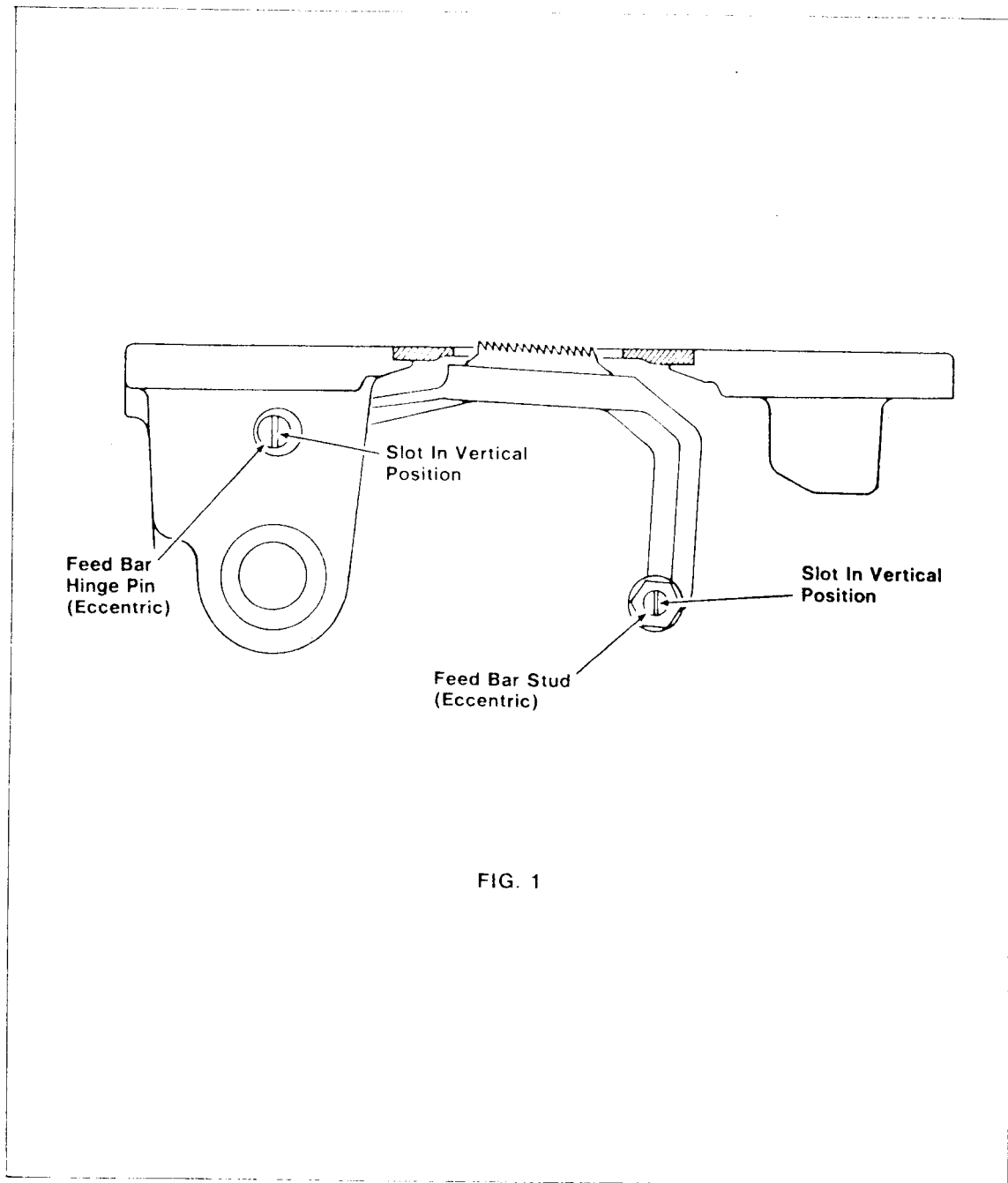

FIG. 1

**TO ADJUST FEED DOG HEIGHT AT .043 INCH
(FOR SEWING ALL TYPES OF MATERIAL
EXCEPT "WASH AND WEAR")**

1. Set machine for sewing approximately 14 stitches per inch.
2. Loosen screws "A" and "B" of feed bar carrier (Fig. 1).
3. Insert screwdriver into hole of bed (Fig. 1), and turn eccentric hinge pin "C" to bring feed dog at maximum height above throat plate with slot positioned vertically.
4. Tighten screws "A" and "B".
5. Loosen nut "D" (Fig. 1).
6. Turn eccentric stud "E" several times. Please note that the feed bar will rock back and forth. Visually position feed bar rock motion towards the operator with slot in vertical position (Fig. 1). Again turn eccentric stud "E", slightly, until feed dog is .043 inch above throat plate as shown in Fig. 2.
7. Tighten nut "D".
8. Always make certain the feed dog does not strike the throat plate.

**TO ADJUST FEED DOG HEIGHT AT .032 INCH
(FOR SEWING "WASH AND WEAR" MATERIALS)**

1. Follow procedure 1 through 8 as noted above except for item 6. Set feed dog .032 inch above throat plate as shown in Fig. 2.

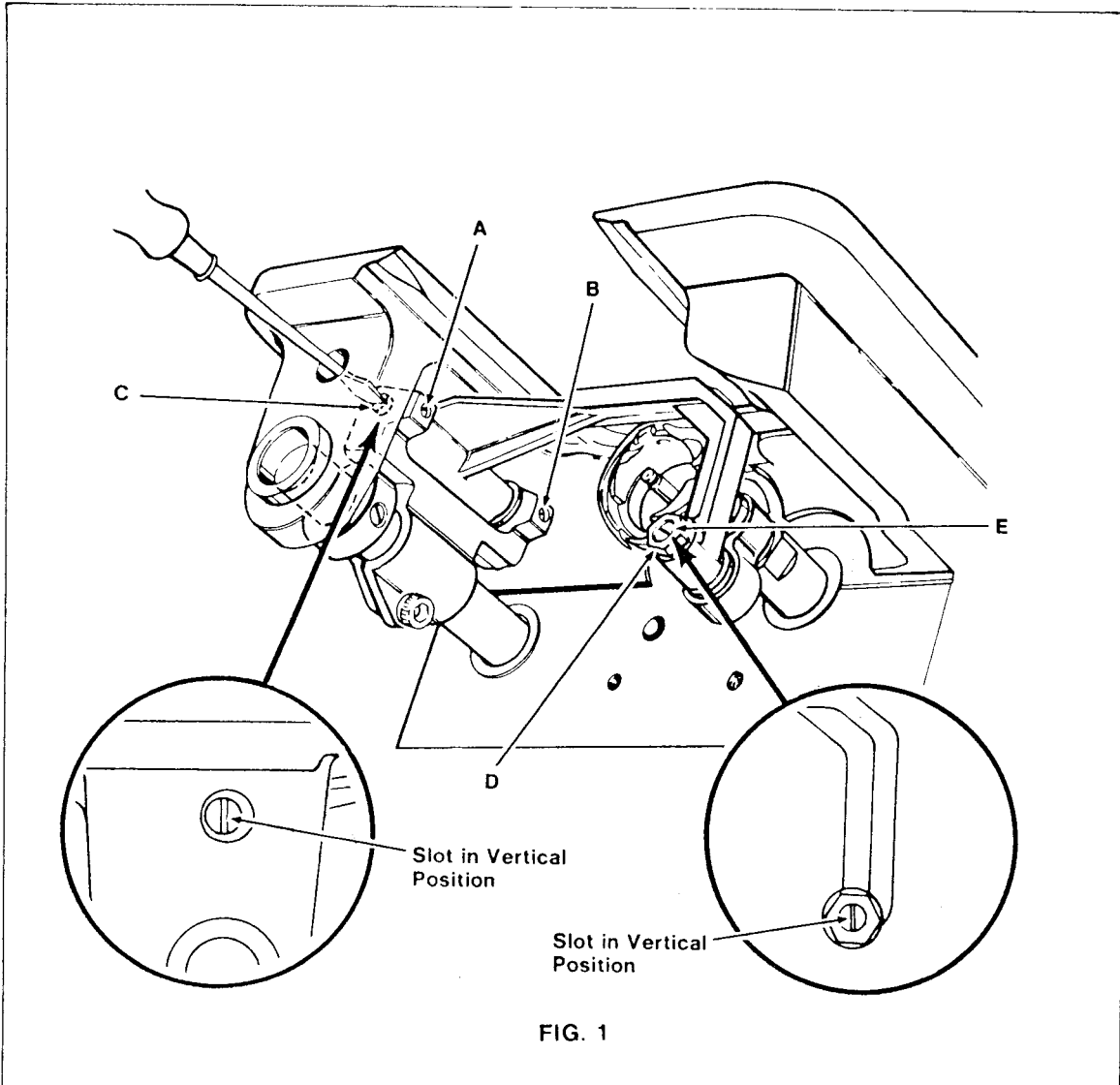

FIG. 1

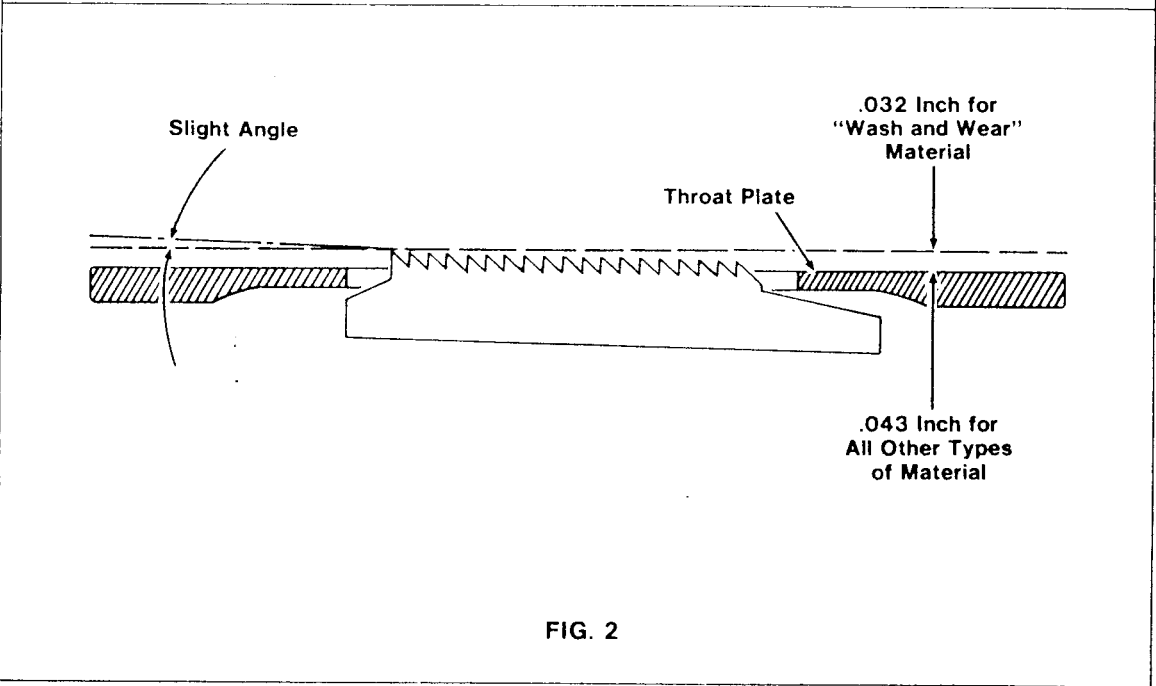
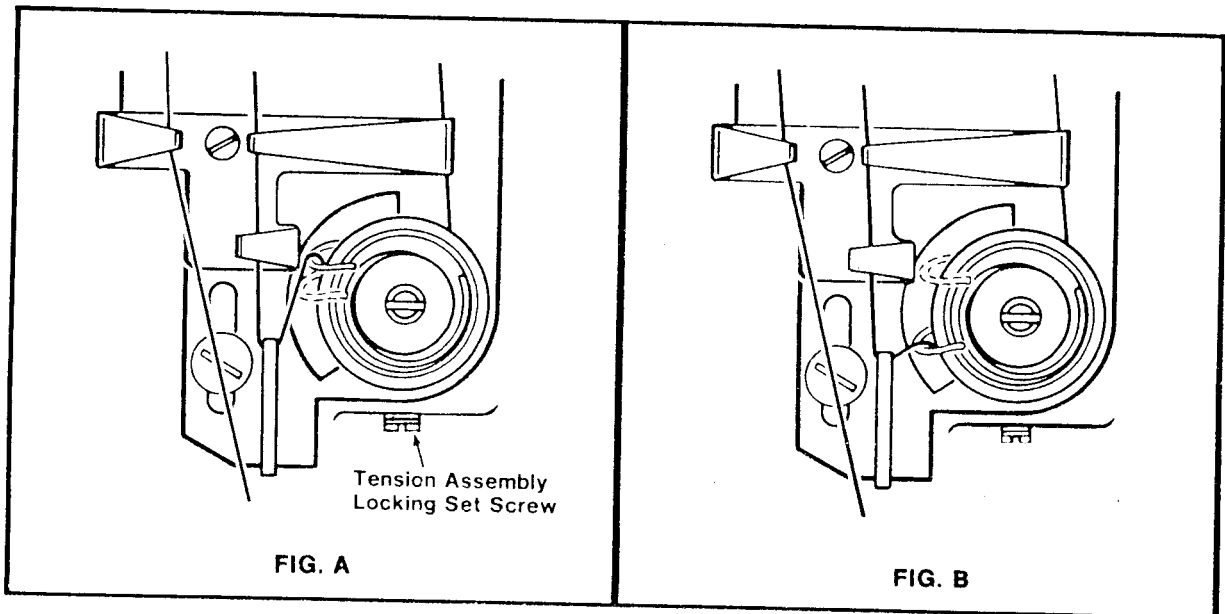

FIG. 2

CHECK SPRING SETTING

HEIGHT - With machine threaded, turn handwheel in direction of machine rotation. As take-up lever begins to rise, the check spring should dip slightly, then return to its original position (Fig. A). When the thread take-up lever approaches the top of its stroke the check spring should be drawn all the way down (Fig. B). As take-up descends the check spring should return to its original position.

To adjust height, loosen locking set screw. Rotate entire tension assembly as required, and retighten set screw.



TENSION

Tension on the check spring should be sufficient to ensure action at top speed, but still light enough to allow spring to be drawn all the way down before any thread is drawn through the tension assembly.

To adjust, securely tighten set screw (Fig. A). Hold thumb nut stationary (Fig. C). Using screwdriver, turn tension stud clockwise to increase tension and counterclockwise to decrease.

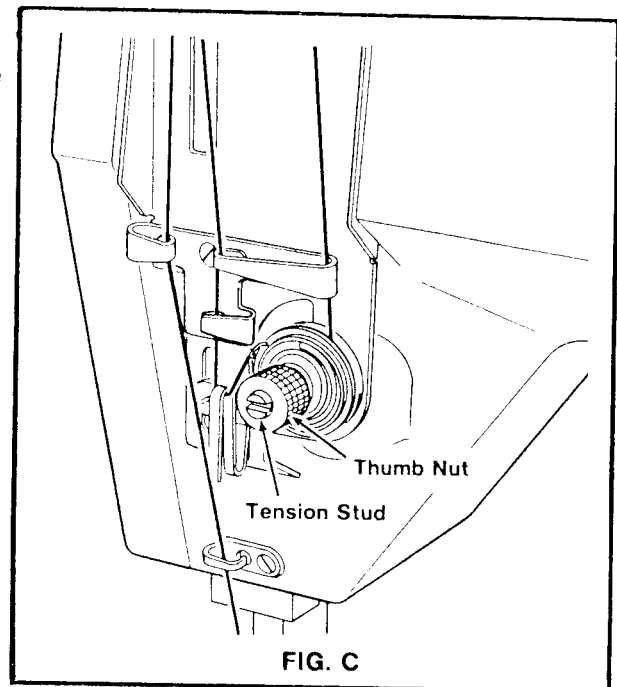

TENSION RELEASE

The tension releasing mechanism should be adjusted so that when the presser foot is raised, using the knee lifter, the tension assembly opens as the presser foot approaches maximum lift.

To adjust, loosen allen cap screw (Fig. A). Move cap screw and block toward **front** of machine to open tension **sooner**, and towards **rear** of machine to open **later**. After desired adjustment, retighten allen screw.

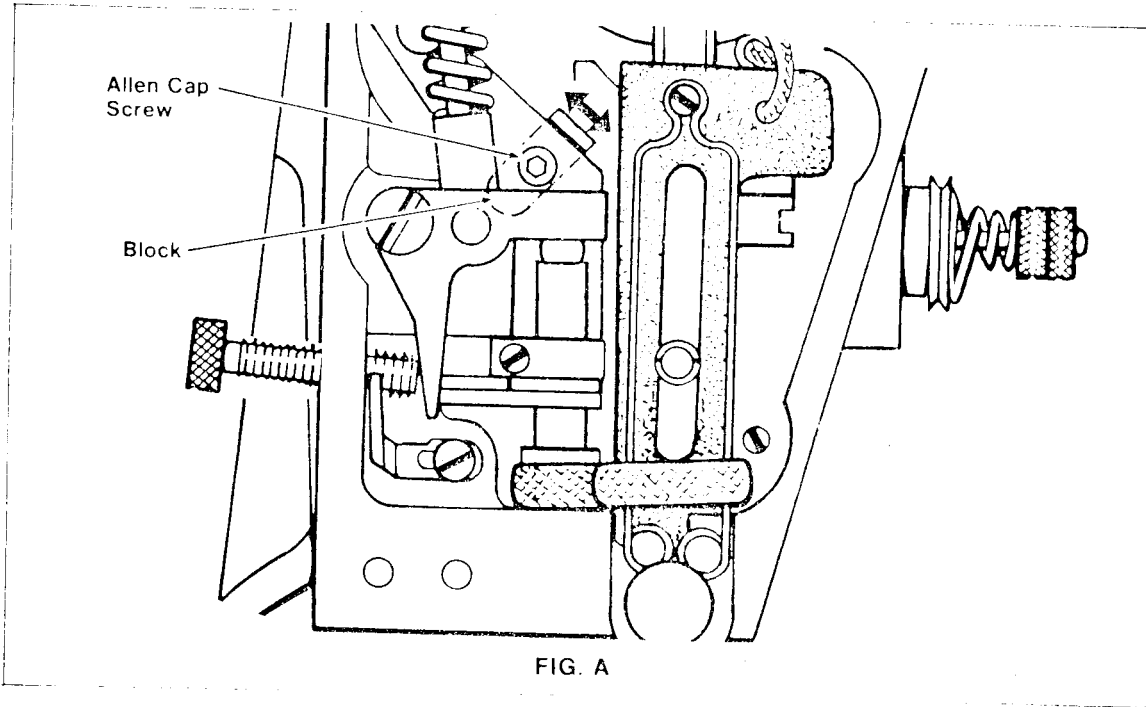

PRESSER BAR AND FOOT SETTING

With feed dog positioned below the throat plate surface, the presser foot must rest firmly on the throat plate and must be located so the needle is centralized between its toes. To adjust, loosen guide bracket clamping screw (Fig. B) and raise or lower bracket as required. A minimum clearance of .015" is required. Turn presser bar to centralize needle. Tighten clamping screw.

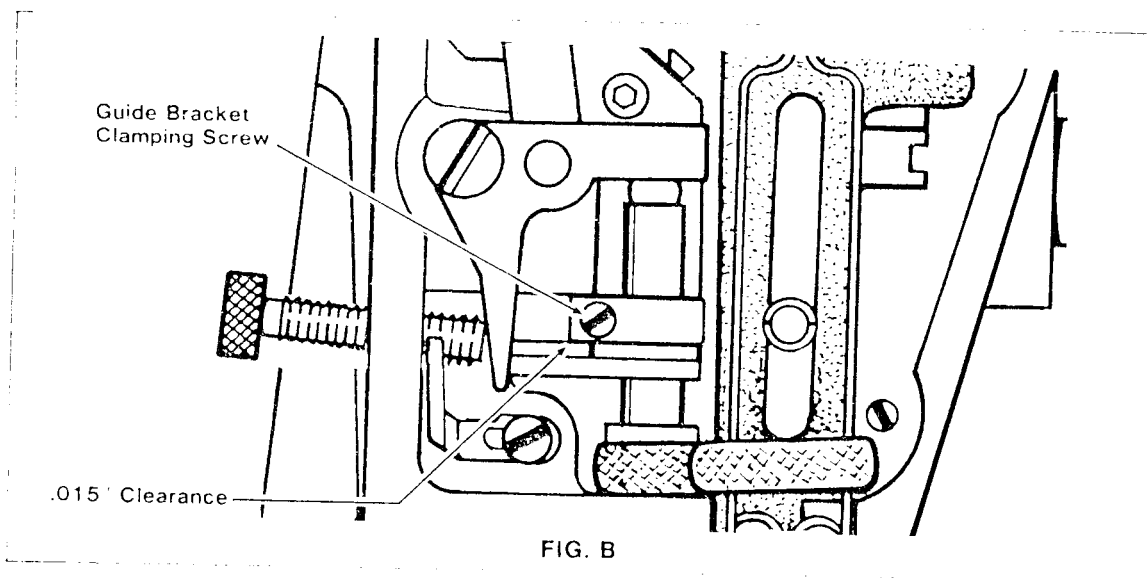

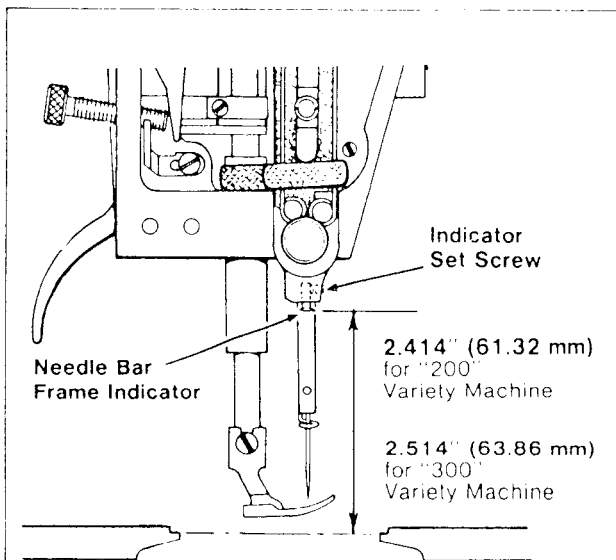

FIG. A

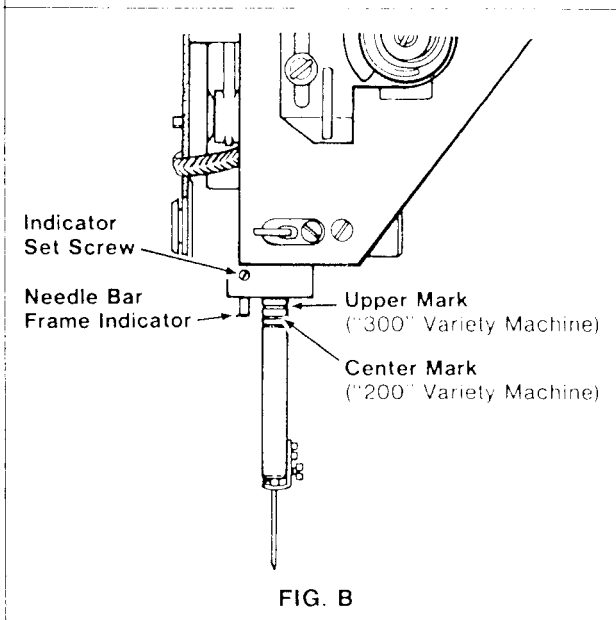

FIG. B

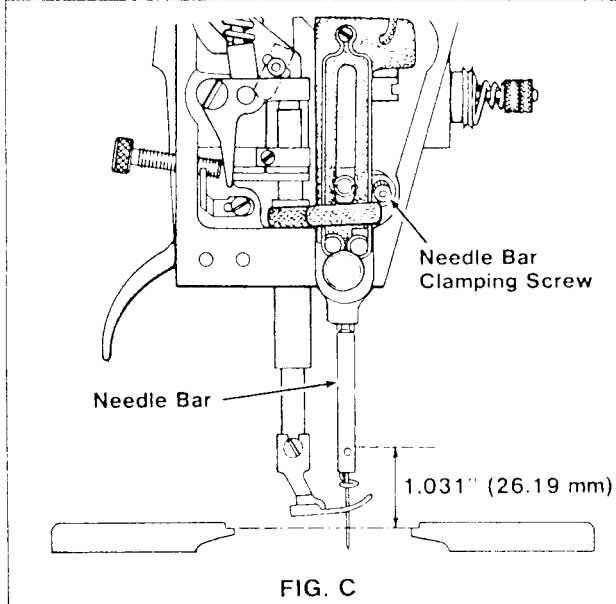

FIG. C

SETTING NEEDLE BAR FRAME TIMING INDICATOR

Gauge distance from throat plate seat to bottom of needle bar frame timing indicator is 2.414 inches (61.32 mm) for "200" variety machines and 2.514 inches (63.86 mm) for "300" variety machines.

Raise or lower needle bar frame indicator as required to obtain correct height setting after loosening indicator set screw shown in Fig. A.

SETTING NEEDLE BAR HEIGHT (using timing marks)

"200" VARIETY MACHINES

Turn machine pulley slowly until needle bar is at its lowest point. Loosen needle bar clamping screw shown in Fig. C and raise or lower needle bar UNTIL THE CENTER MARK IS LEVEL WITH THE INDICATOR as shown in Fig. B.

"300" VARIETY MACHINES

Turn machine pulley slowly until needle bar is at its lowest point. Loosen needle bar clamping screw shown in Fig. C and raise or lower needle bar UNTIL THE UPPER MARK IS LEVEL WITH THE INDICATOR as shown in Fig. B.

SETTING NEEDLE BAR HEIGHT (without using timing mark)

Remove face plate, slide plate and throat plate.

When needle bar is at its lowest point (during rotation of machine pulley), the gauge distance from throat plate seat to needle stop in needle bar is 1.031 inches (26.19 mm) (Fig. C).

To set needle bar height, loosen the needle bar clamping screw shown in Fig. C. Raise or lower needle bar as may be required. Securely tighten clamping screw. Replace all parts previously removed.

BOBBIN WINDER DRIVE WHEEL ADJUSTMENT

1. Remove rear arm cover plate and loosen drive wheel set screws.
2. Mount bobbin winder assembly to arm casting. Do not tighten holding screws.
3. With engaging lever in engaged position, slide bobbin winder assembly to the left (toward the sewing head end of the machine) as far as the holding screw slots will allow. Tighten holding screws.
4. Move drive wheel on arm shaft until it touches driven wheel. Tighten set screws.

BOBBIN WINDER DRIVEN WHEEL ADJUSTMENT

5. Loosen bobbin winder holding screws 1 to 2 turns.
6. Using a push or pull scale, exert 2 to 3 pounds of pressure on the assembly and tighten holding screws while pressure is being exerted.

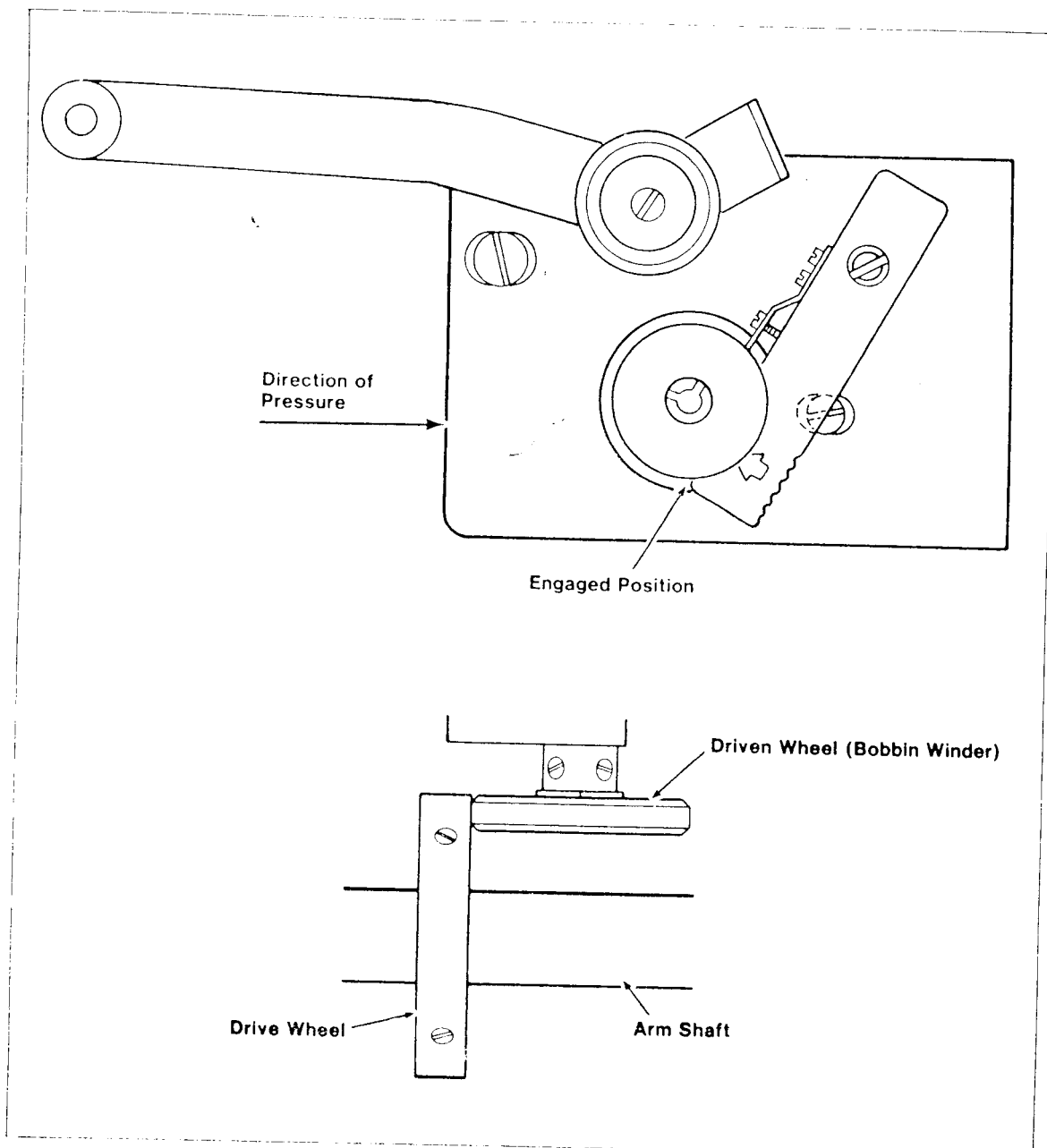

TO ADJUST BOBBIN WINDER

1. Loosen set screw at top end of engaging lever. With screw driver in slot hold shaft stationary and move lever as required to obtain desired amount of thread on bobbin. Move to right for more thread and left for less. Retighten set screw.
2. Loosen set screw in collar of thread guide. Move guide in or out to obtain even wind on bobbin. Retighten set screw.
3. Adjust tension as required: in (clockwise) for more and out (counterclockwise) for less.
4. Use fine adjustment lever for filling bobbin to an exact amount.

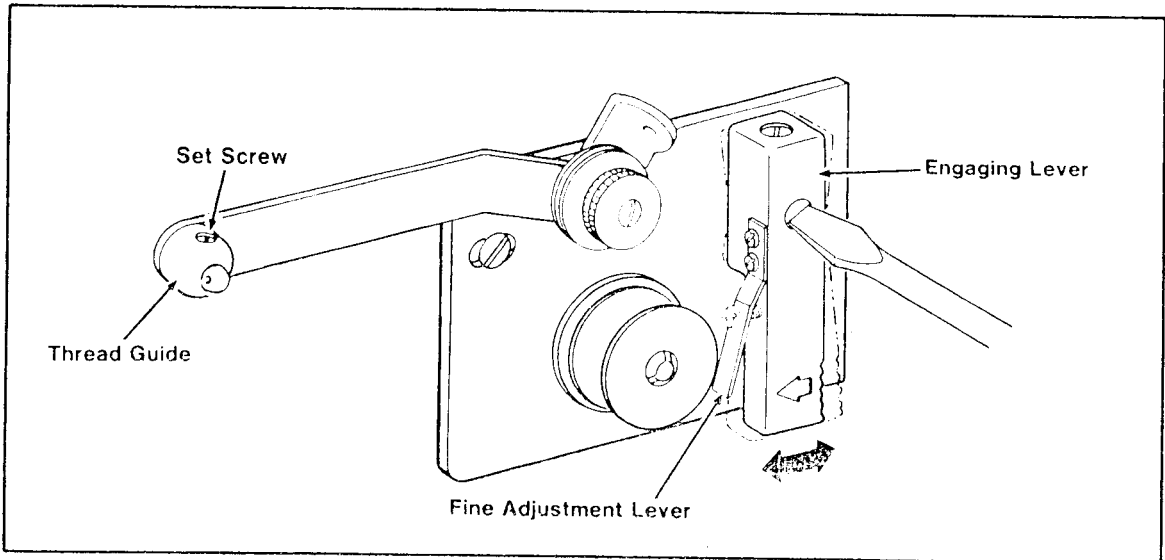

To thread bobbin winder, lead thread from thread stand through thread retainer, wrap a complete turn around tension stud of tension mechanism, thread guide, to bobbin. Wrap bobbin clockwise.

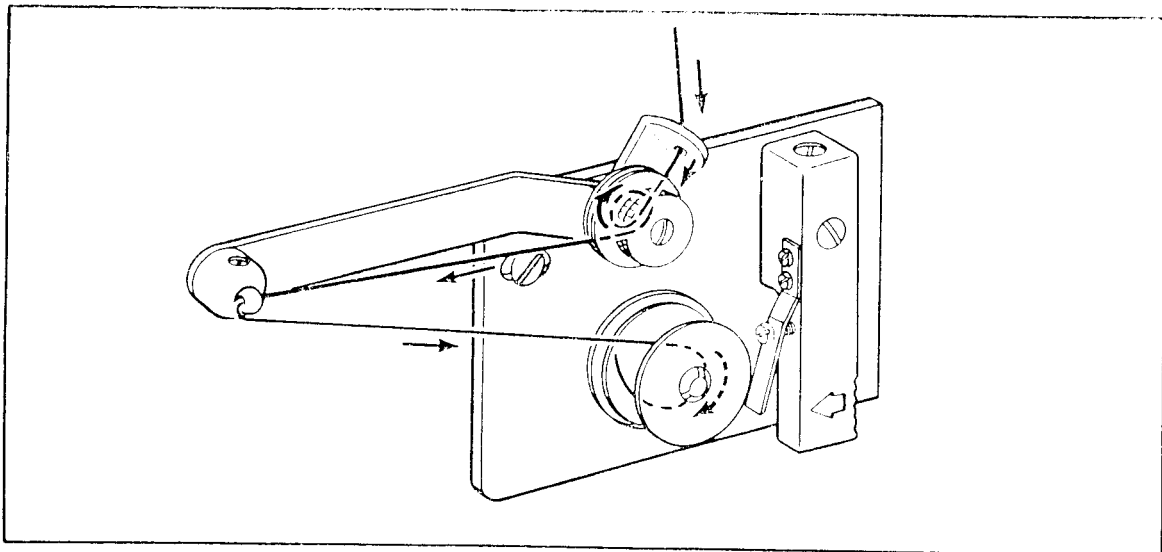

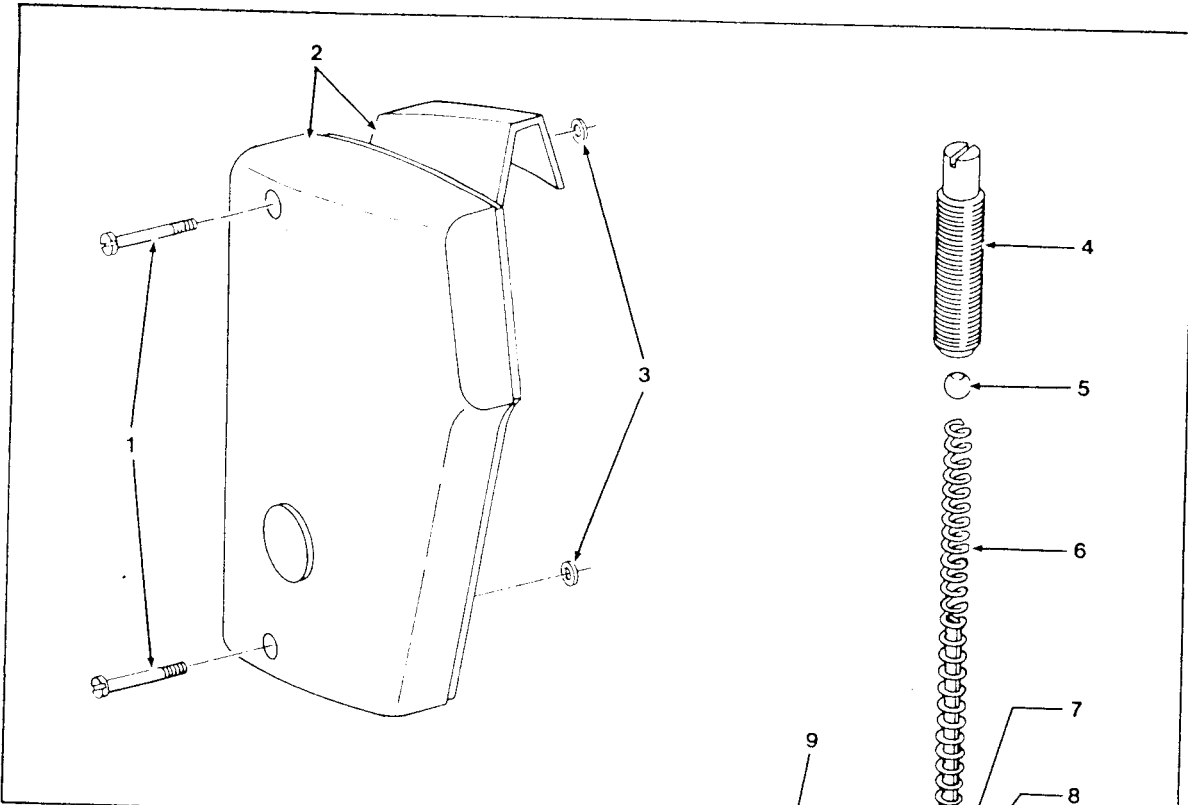

DISASSEMBLY SEQUENCE

PRESSER BAR

1. Remove face plate mounting screws.
2. Remove face plate and thread take-up lever guard complete.
3. Remove face plate washers.
4. 5, 6, 7, & 8. Unscrew and remove regulating screw, steel ball, spring, washer and rod complete.
- 9, & 10. Unscrew and remove pressure lever mounting screw and lever complete.
11. Unscrew and remove presser bar pressure lever adjusting screw.
- 12, & 13. Remove lower spring and guide complete.
14. Remove presser foot screw.
15. Remove presser foot.
16. & 17. Loosen bracket clamping screw and remove bracket.
18. Remove delrin spacer.
19. Rotate hand wheel until take-up mechanism is out of presser bar removal path. Lift presser bar up and out.

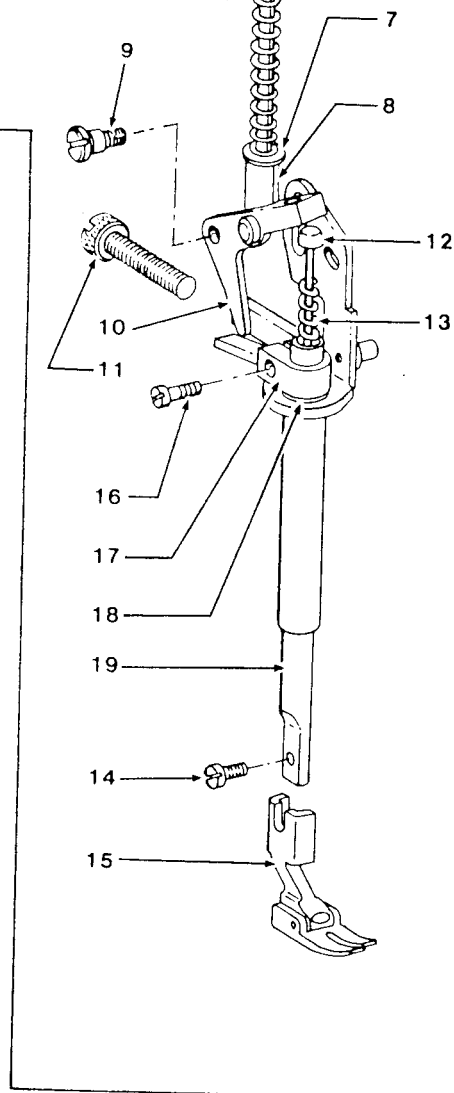

DISASSEMBLY SEQUENCE

NEEDLE BAR FRAME AND TAKE-UP MECHANISM

1. Remove 5 rear arm cover mounting screws.
2. Remove rear arm cover and gasket.
3. Loosen needle holding screw and remove needle.
4. Remove oil wick from take-up hinge stud and tab felt pad of the needle bar frame.
5. Remove sucker wick from needle bar frame.

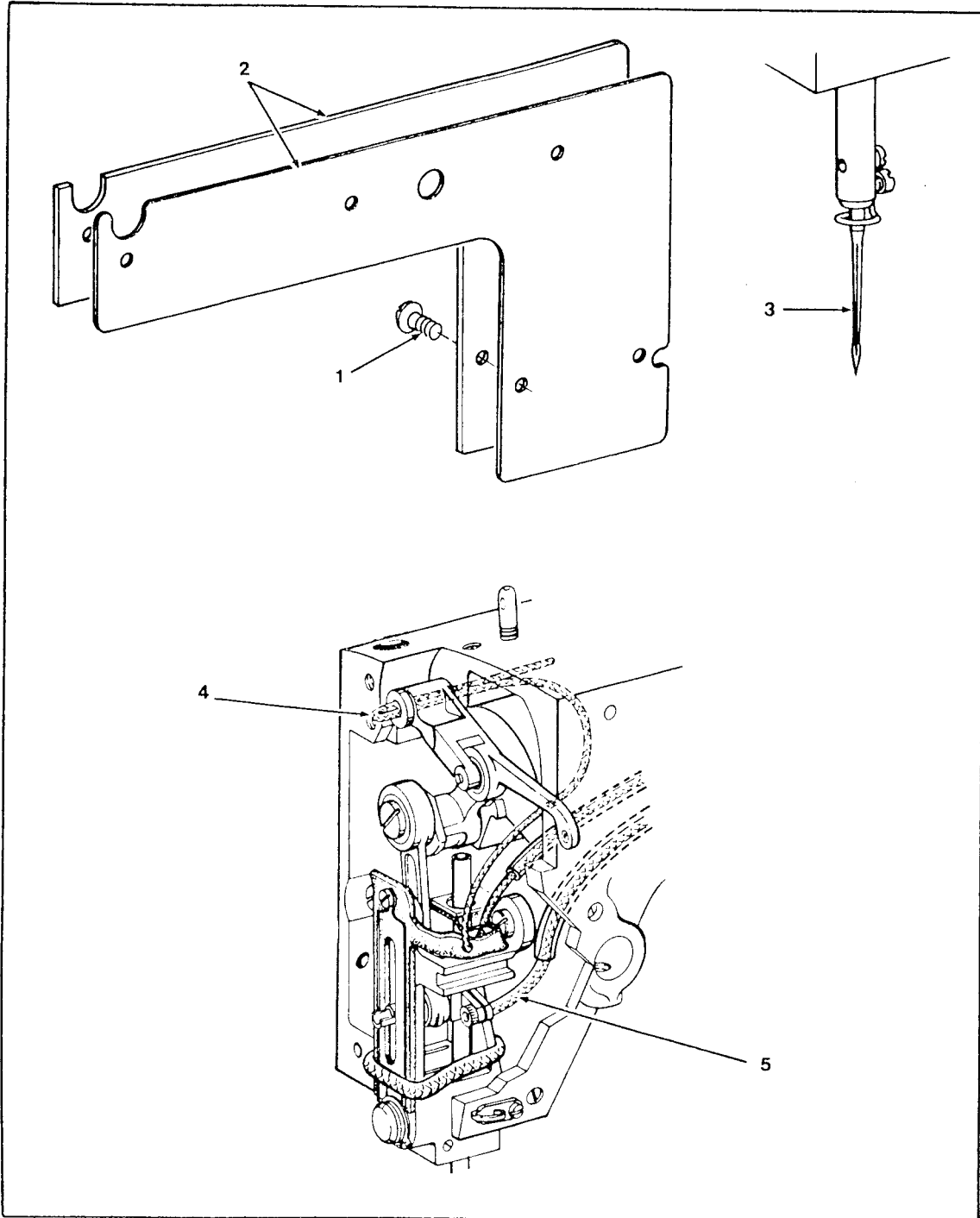

DISASSEMBLY SEQUENCE

NEEDLE BAR FRAME AND TAKE-UP MECHANISM (Cont'd)

6. Remove thread guide.
7. Loosen take-up hinge stud mounting set screws.
8. Loosen needle bar crank set screw and clamping screw.
9. Loosen needle bar frame mounting screw (upper).
10. Loosen needle bar frame mounting screw (lower).
11. Remove take-up hinge stud.
12. Remove needle bar frame and take-up mechanism as a complete assembly.
13. Remove needle bar crank spacing washer.

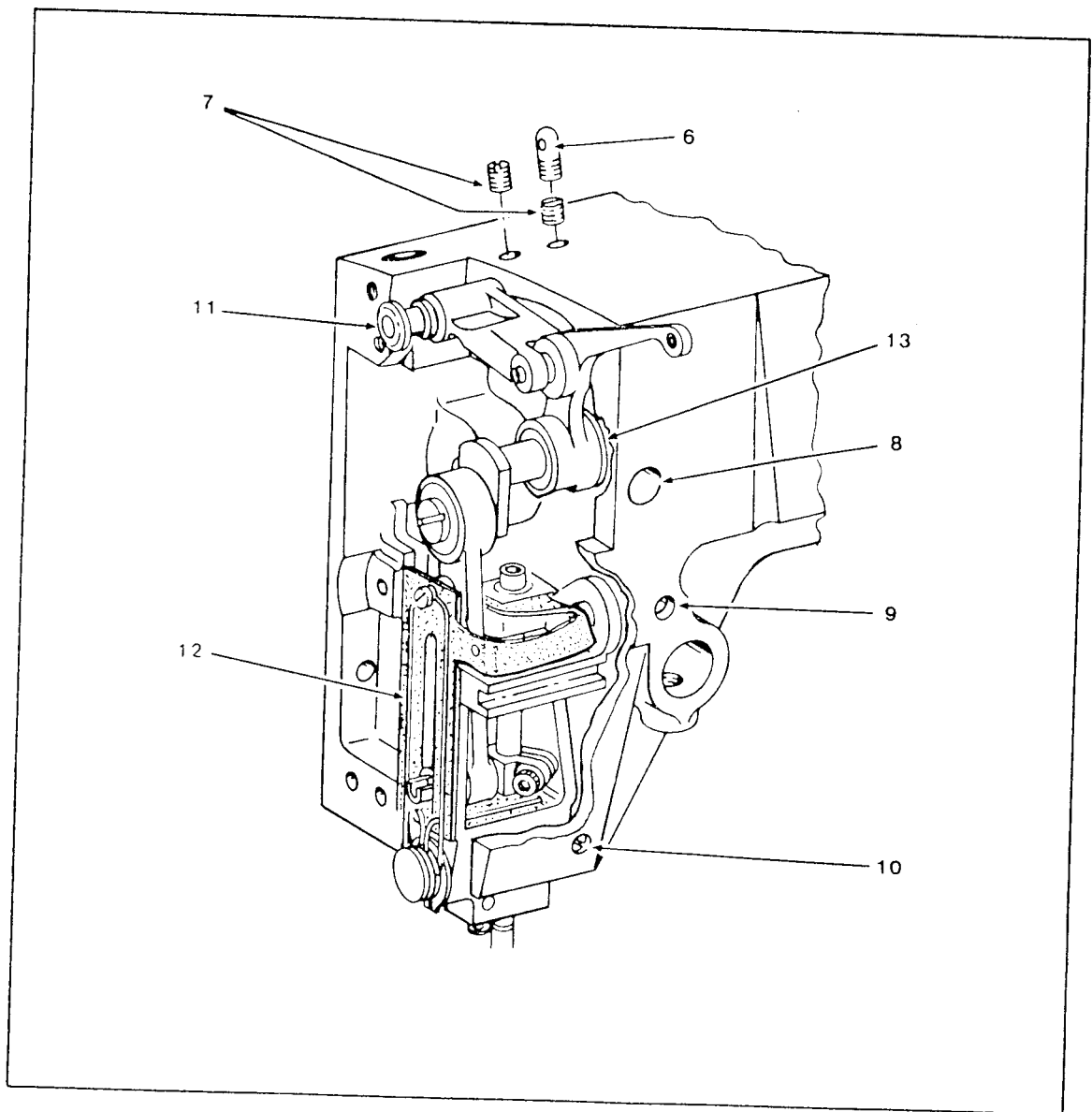

DISASSEMBLY SEQUENCE

TENSION RELEASE MECHANISM

1. Remove lifting link screw and link.
2. Remove presser bar pressure lever adjusting screw tension clip and screw.
3. Remove tension releasing lever mounting screw, lever and spring.
4. Remove hand lifting lever mounting screw and lever.
5. Remove tension releasing pin.

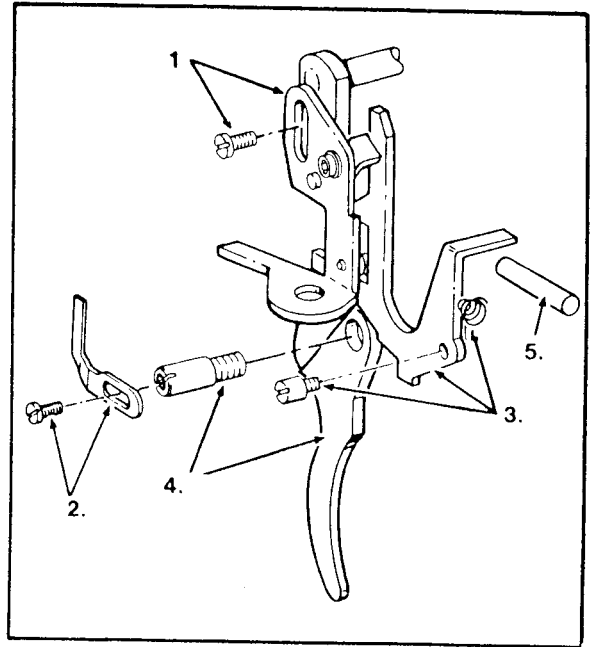

ARM SHAFT

1. Loosen set screws (2 ea.) in each of the components named in the illustration below. The handwheel should then be removed, exposing the right end of the shaft.
2. With a soft-faced mallet, lightly tap arm shaft from right to left until front arm shaft bearing is free of casting. Pull arm shaft from machine, right to left.

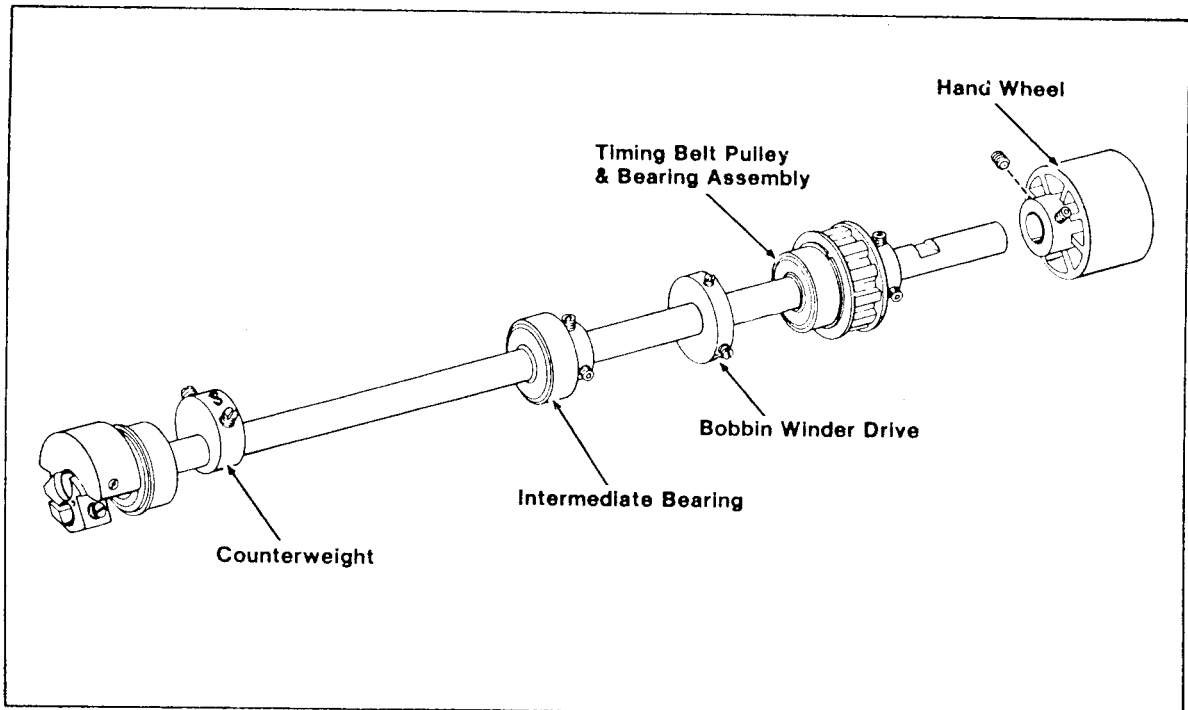

DISASSEMBLY SEQUENCE

FEED LIFTING SHAFT

1. Remove bed cover plate, drain oil from reservoir, and remove oil reservoir cover.
2. Remove height eccentric locking nut.
3. Loosen feed bar carrier pinch screw.
4. Slide carrier assembly left to clear feed bar from height eccentric stud. This will give access to feed lifting link screw.
5. Loosen set screws (2 each) in the following components: drive pulley, timing belt pulley, feed eccentric, collar and gear as shown in illustration.
6. Remove drive pulley and flange.
7. Unhook oil pump spring.
8. Remove feed lifting link screw (left hand thread).
9. Remove shaft from left to right.

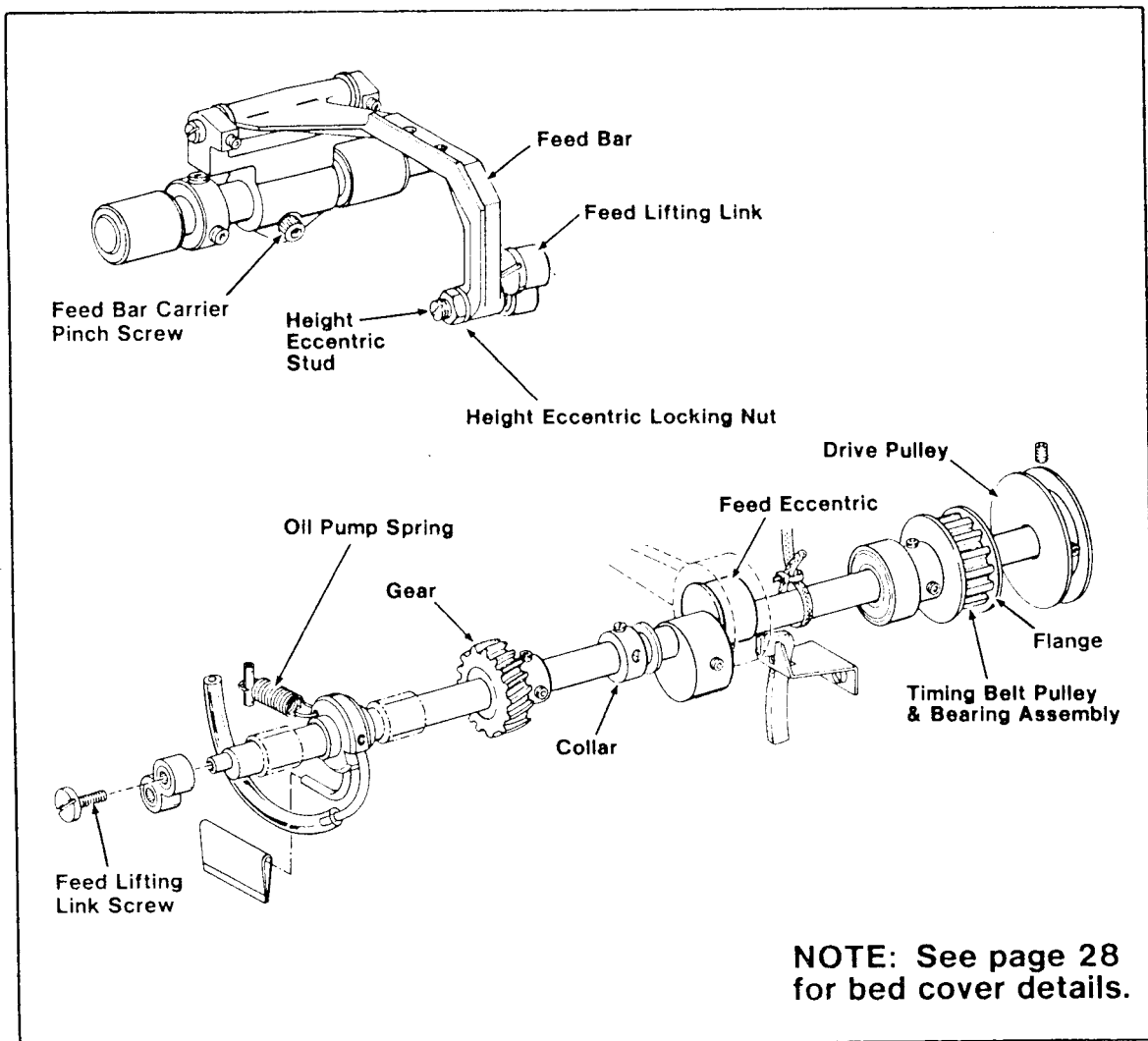

DISASSEMBLY SEQUENCE

FEED ROCK SHAFT

1. Loosen set screws (2 ea.) in collars.
2. Loosen clamping screw in feed reversing crank.
3. Loosen clamping screw in feed bar carrier.
4. Remove shaft from right to left.

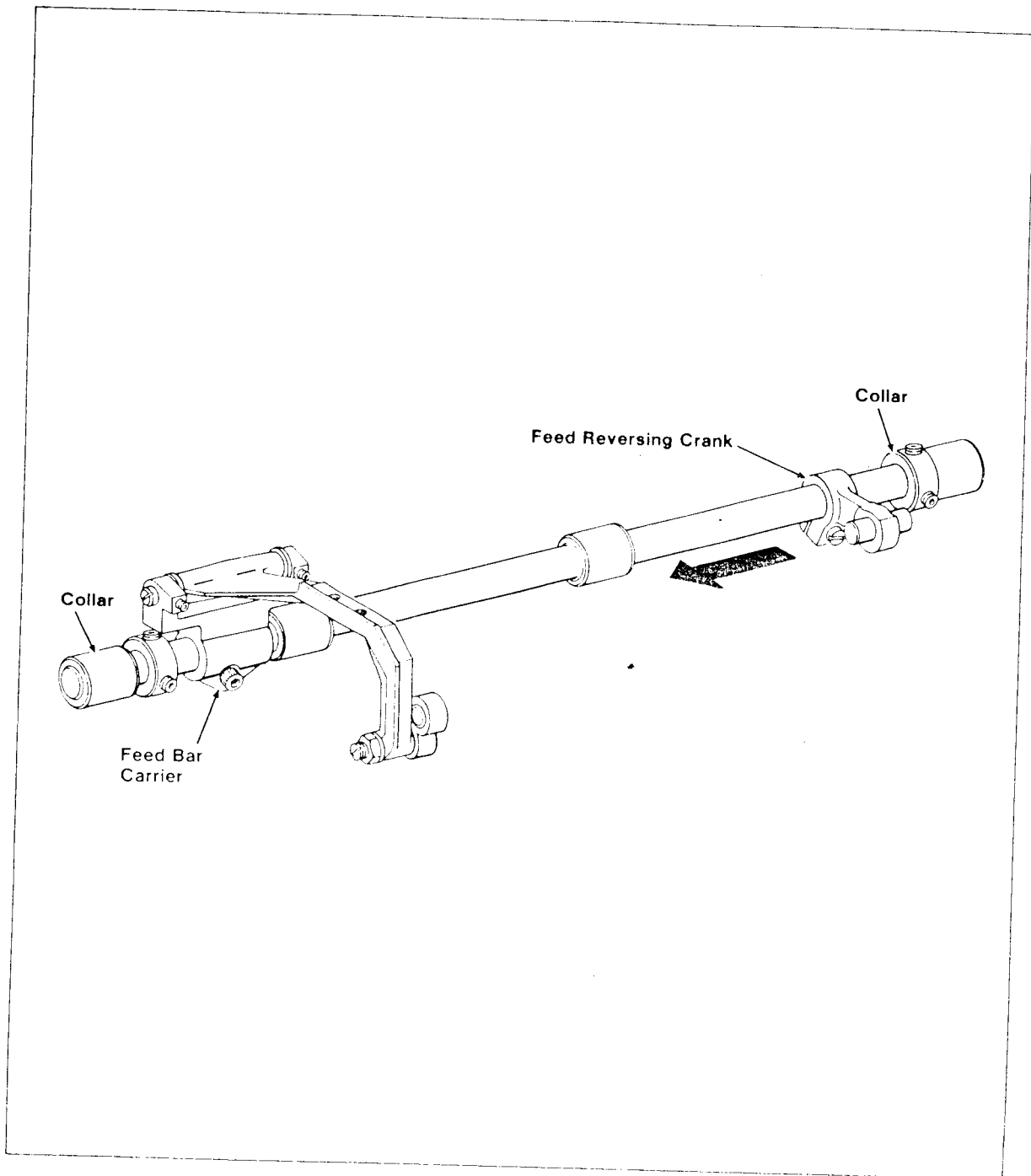

DISASSEMBLY SEQUENCE

FEED REVERSING MECHANISM

1. Remove screw from vertical link
2. Loosen set screws in drive assembly
3. Loosen set screws in collar (2 ea.)
4. Loosen set screws in dynamic damper (2 ea.)
5. Slip short shaft from left to right and long shaft from right to left, remove drive assembly. Remove shafts, collar and dynamic damper.

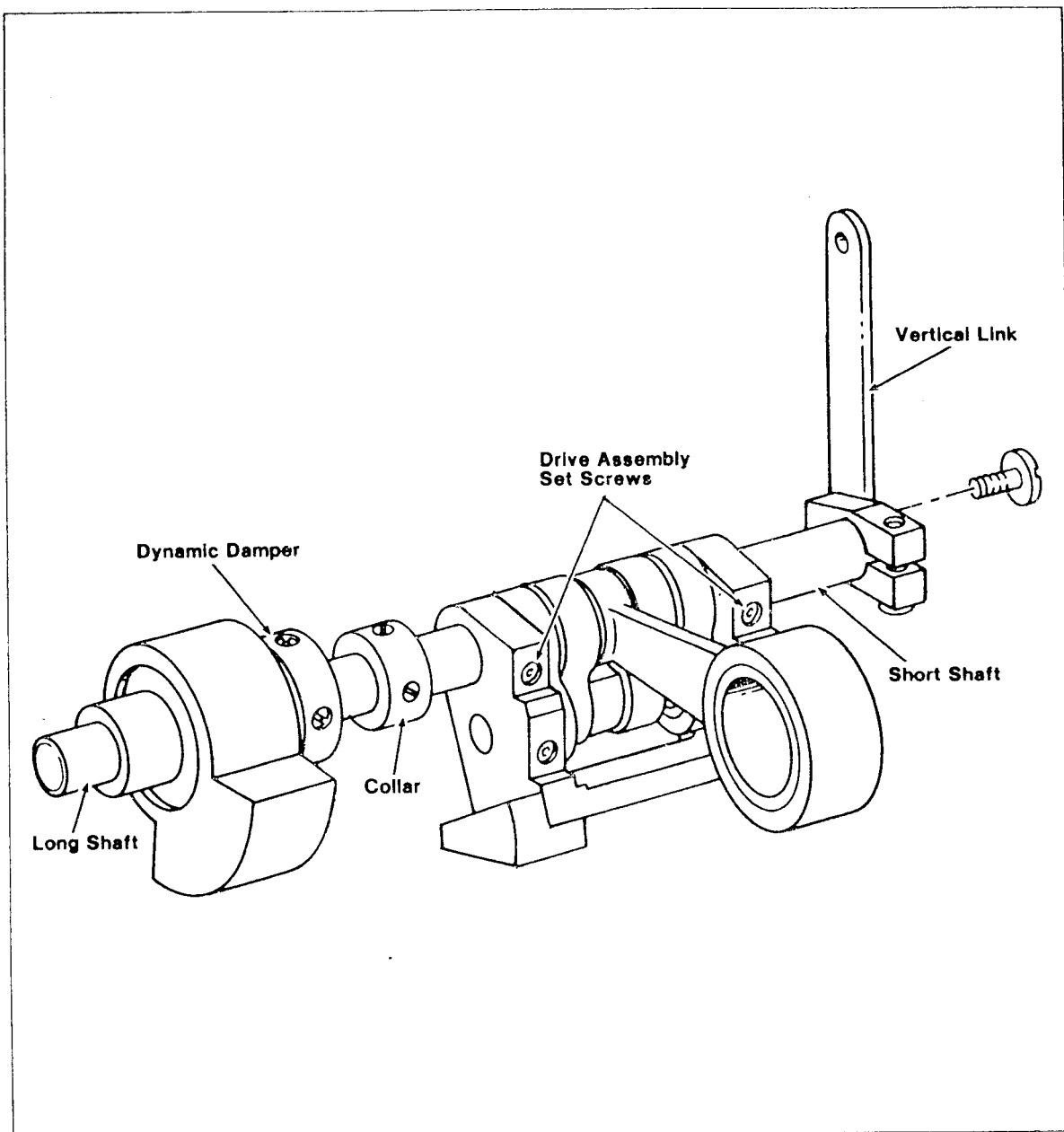

DISASSEMBLY SEQUENCE

FEED REVERSING LEVER MECHANISM

1. Remove variety plate with thin screwdriver as shown. Insert screwdriver between variety plate and cover plate and twist.
2. Remove stitch indicator cover plate unit and light box.
3. Loosen reversing lever shaft set screw (in arm casting).
4. Loosen set screws in collars (2 each).
5. Slip shaft out from right to left (as viewed from rear of machine).
6. Remove collars and spring.
7. Remove reversing lever and vertical link as one assembly.

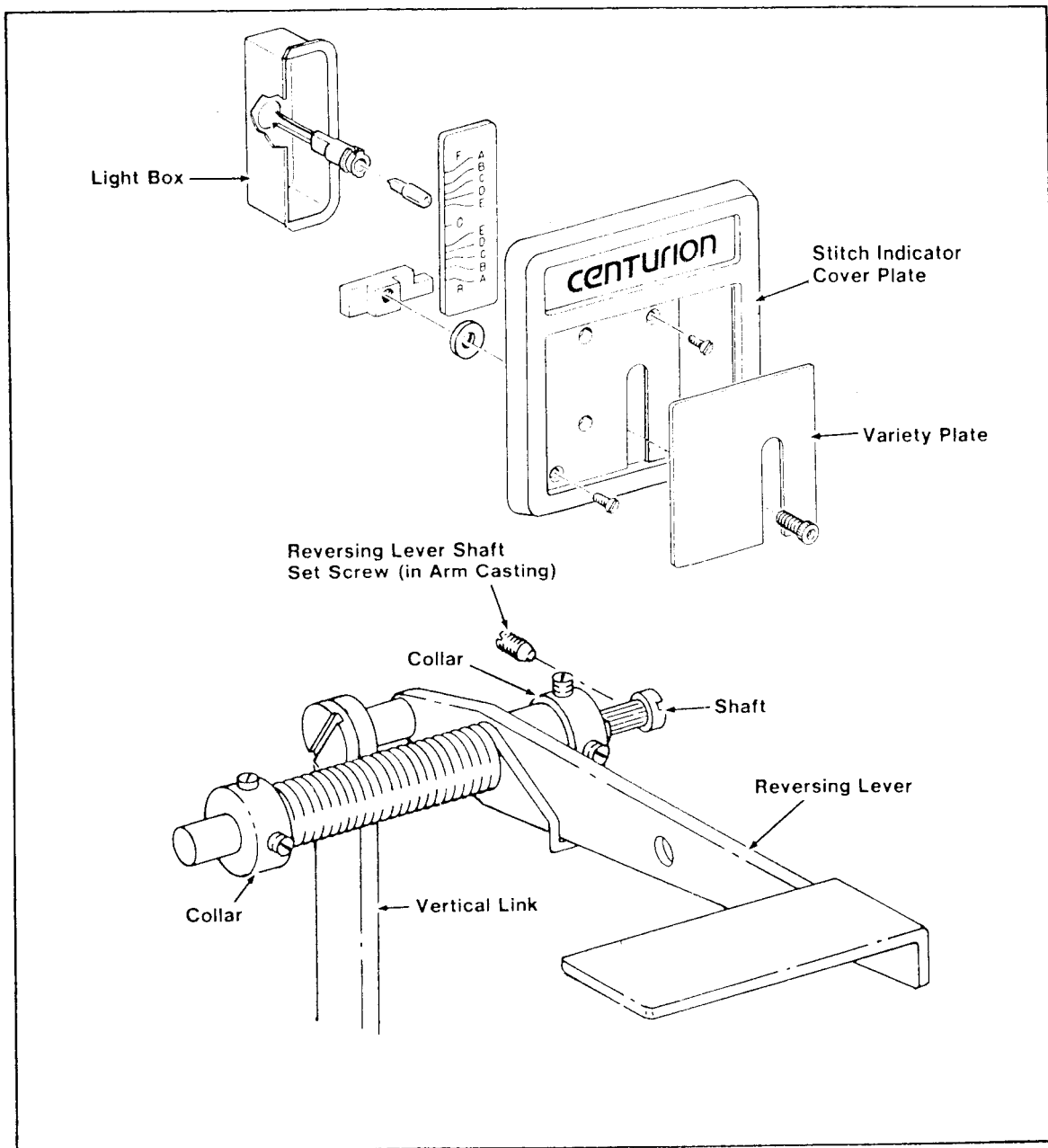
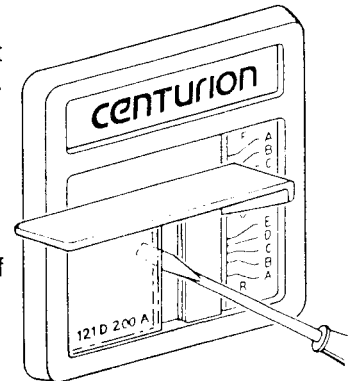

DISASSEMBLY SEQUENCE

KNEE LIFT MECHANISM

1. Remove knee lift extension bar assembly.
2. Remove screw, washer and spring clip from bed casting.
3. Remove hex nut, washer and eccentric cam stud from bed casting.
4. Remove hex nut and washer.
5. Remove screw.
6. Pull stud out.
7. Loosen sleeve set screw from bed casting.
8. Remove "E" ring and link from bell crank, unscrew link from pivot pin and remove with oil seal.
9. Loosen set screws in stop arm, collar and crank.
10. Remove shaft from rear to front, collar, sleeve, stop arm with spring, drum assembly and rock shaft crank with pivot pin.
11. Remove "E" rings and vertical link from bell crank and presser bar lifting crank.
12. Remove screws and bell crank assembly with bracket.
13. Loosen set screws in collar and crank.
14. Remove shaft, thrust washer, collar and crank.

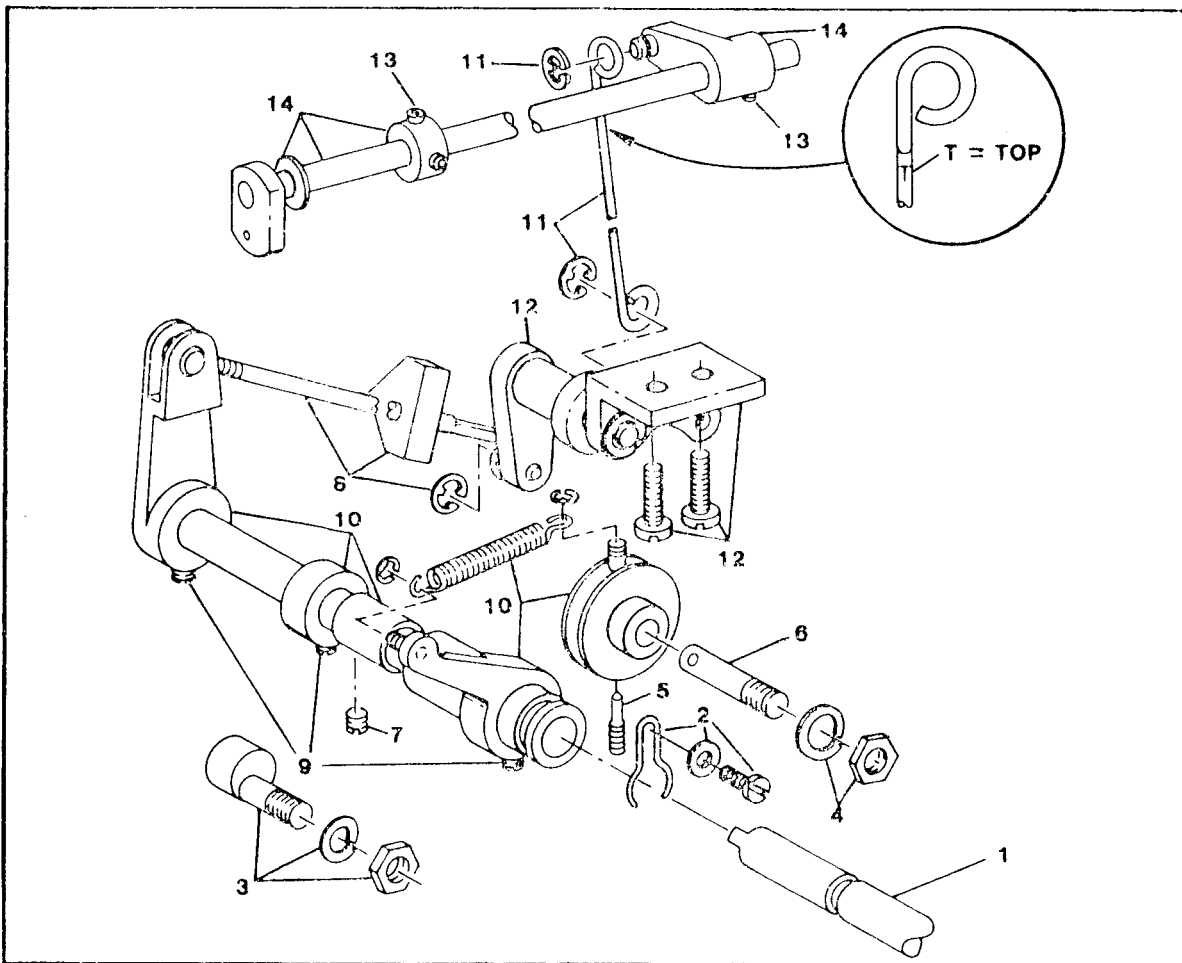

DISASSEMBLY SEQUENCE

HOOK SHAFT & BUSHING

1. Remove throat plate, feed dog, position finger and hook assembly.
2. Remove bed cover pan cover and bed cover pan.
3. Remove feed rock shaft (as per prior instructions).
4. Move feed bar to allow clearance for bushing removal.
5. Drain oil and remove oil reservoir cover.
6. Remove oil line & fitting from bushing.
7. Loosen hook shaft bushing set screw.
8. Remove hook shaft & bushing as a complete assembly.

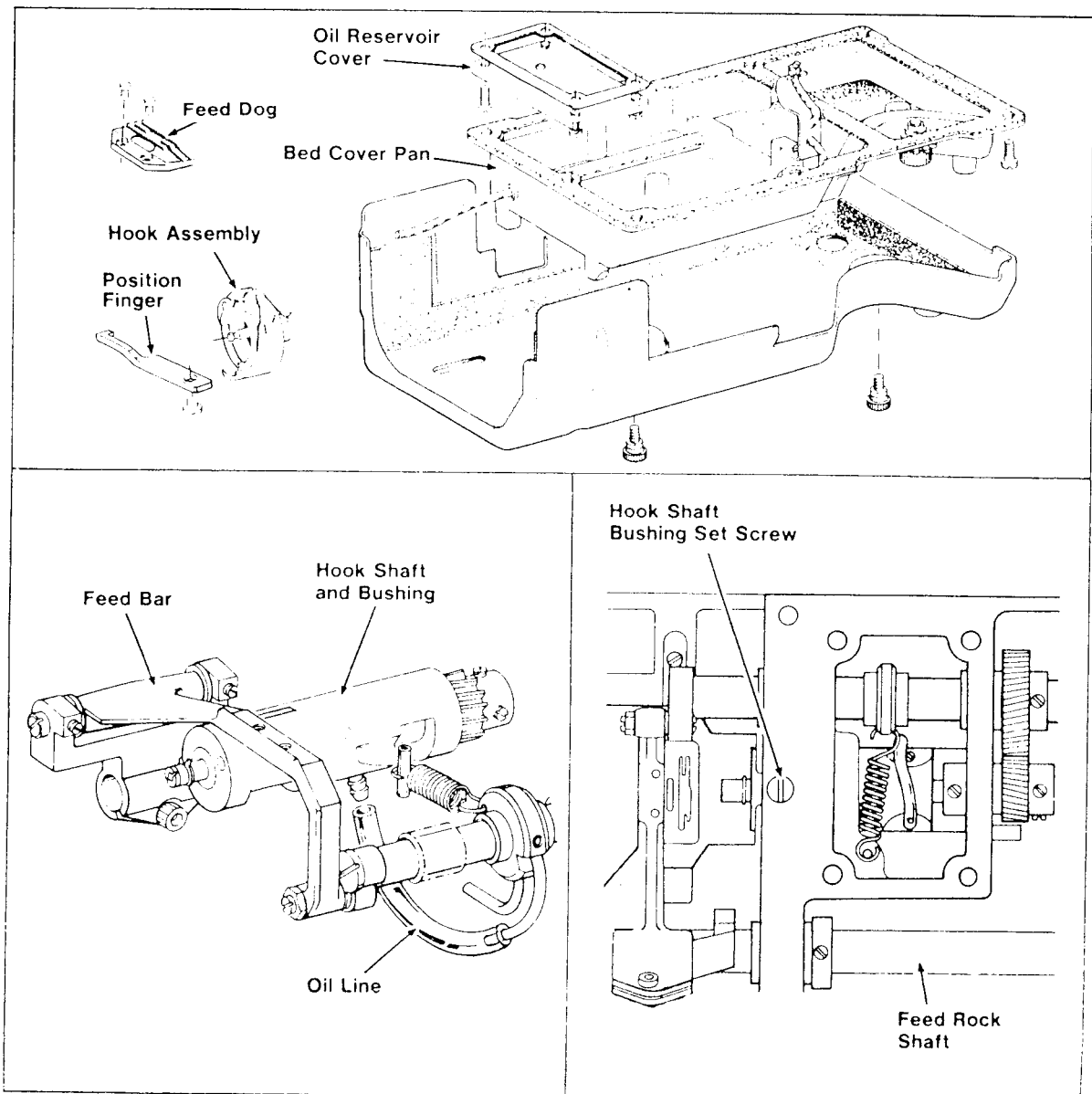

ASSEMBLY SEQUENCE

FEED REVERSING LEVER MECHANISM

1. Position feed reversing lever and vertical link as one assembly, inside arm standard as shown.
2. Insert shaft through arm standard with two collars, spring and reverse lever mounted to it as shown.
3. Assemble stitch indicator cover plate, light box, reverse lever stopping block and the stitch indicator cover plate unit.
4. Centralize shaft in arm standard axially with left collar up against casting wall. Tighten set screws.
5. Insert left end of spring into collar (hole provided).
6. Hook right end of spring under reversing lever.
7. Centralize reversing lever in slot of stitch indicator cover plate. Set right collar up against hub of reversing lever and tighten set screws.

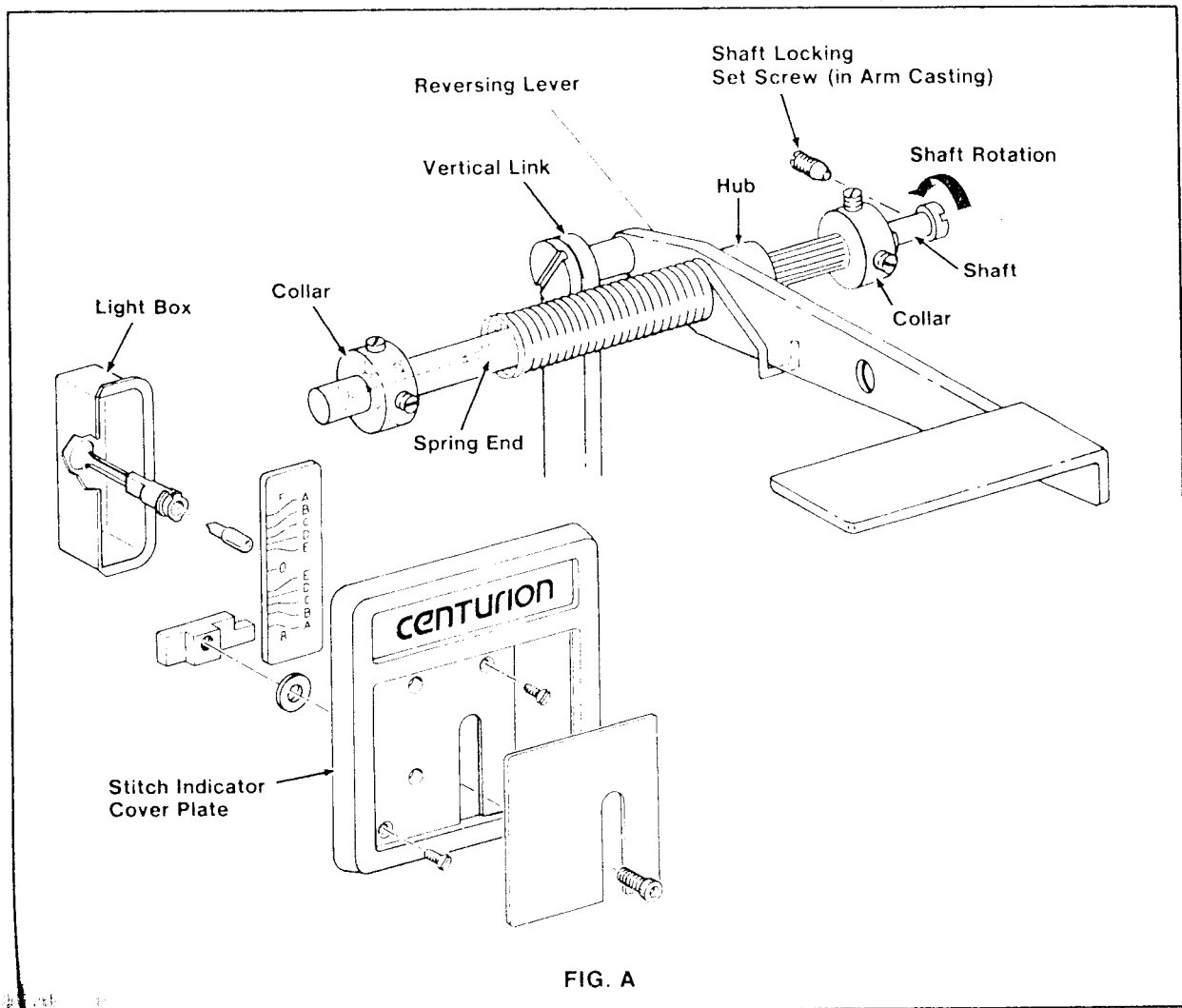

ASSEMBLY SEQUENCE

FEED REVERSE DRIVE ASSEMBLY

1. Insert long shaft, from right to left, through casting, collar and dynamic damper assembly.
2. Insert feed reversing drive assembly onto long shaft end, fitting the flattened surface.
3. From right to left insert short shaft through casting into drive assembly.
4. Tighten set screws in drive assembly.
5. Tighten set screws of dynamic damper onto flats of shaft.
6. Move entire assembly to left until touching casting. Move collar to right until touching casting. Eliminating any end play, tighten set screws in collar.
7. Install crank and attach vertical link to crank.
8. Rotate feed reversing lever shaft until sufficient spring pressure is attained to hold reversing lever in upward position. Tighten shaft locking set screw (Fig. A, page 29).

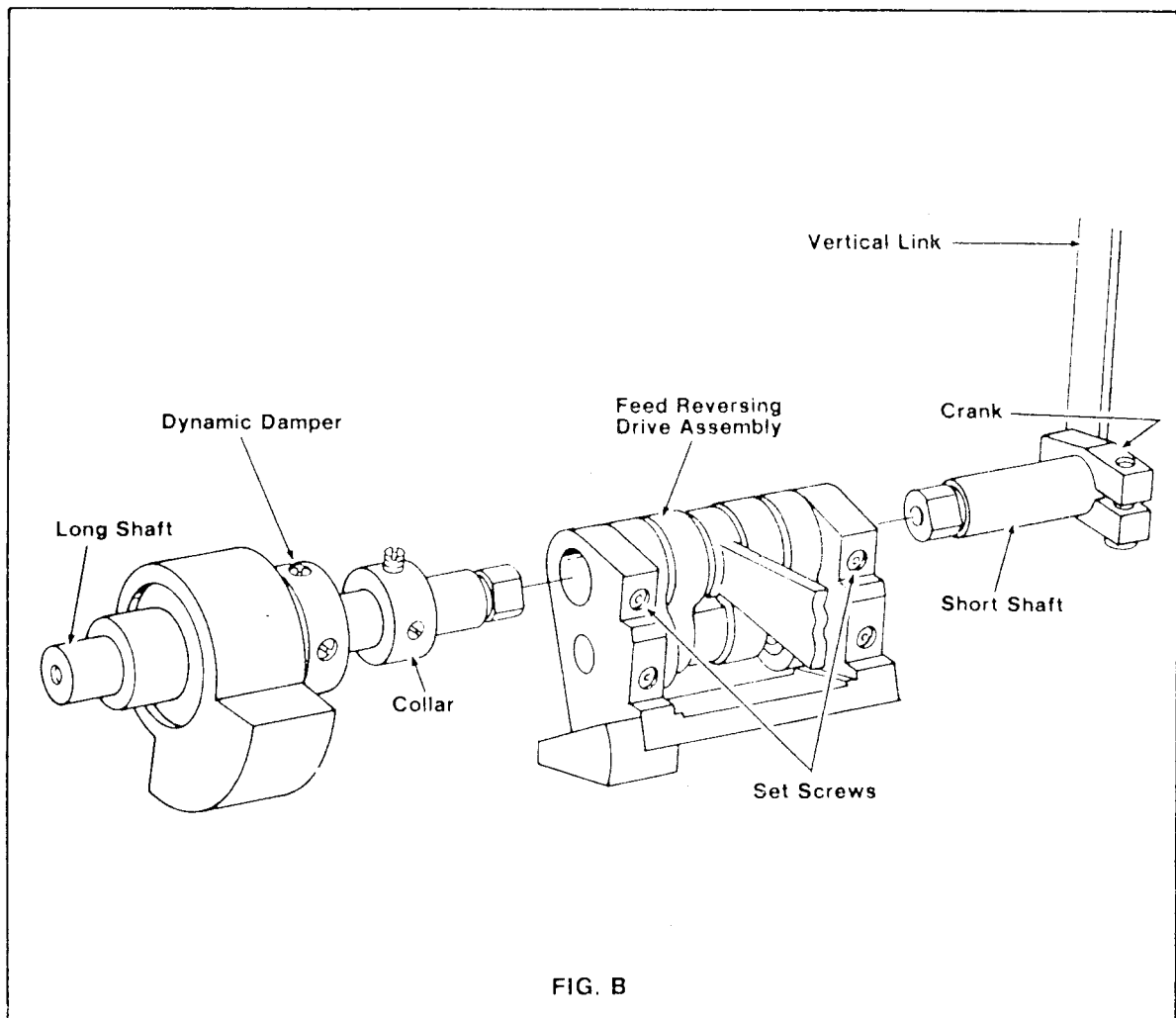

ASSEMBLY SEQUENCE

FEED ROCK SHAFT

1. Insert shaft from left to right through collar, feed bar carrier, feed reversing crank, and collar. Set shaft flush with left bearing face. Move left collar to left until touching bearing face. Tighten set screws. Move right collar to right eliminating end play (max. .001"). Tighten set screws.
2. Set feed reversing lever and drive assembly at neutral position (no feed). Tighten feed reversing crank pinch screw.

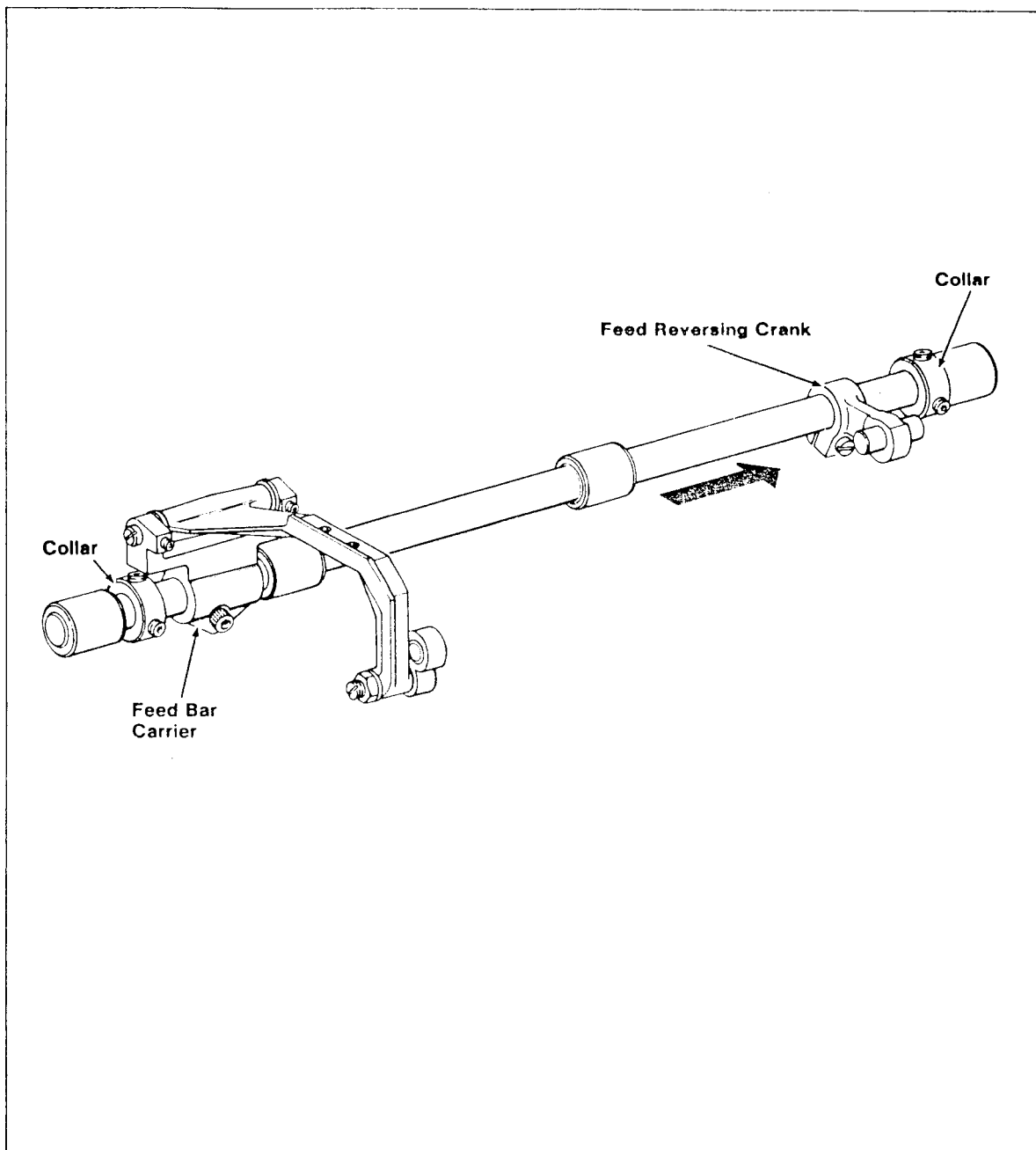

ASSEMBLY SEQUENCE

FEED LIFTING SHAFT

1. Insert shaft from right to left through loop in wicking, feed eccentric, thrust washer, collar, gear, oil pump and into feed bar lifting crank. Replace screw.
2. Rotate shaft to expose flats.
3. Replace flange and drive pulley. Tighten first set screw in direction of machine rotation onto flats of shaft in the gear, feed eccentric, and drive pulley.
4. Move collar to right eliminating end play (max. .001"). Tighten set screws. Tighten balance of set screws.

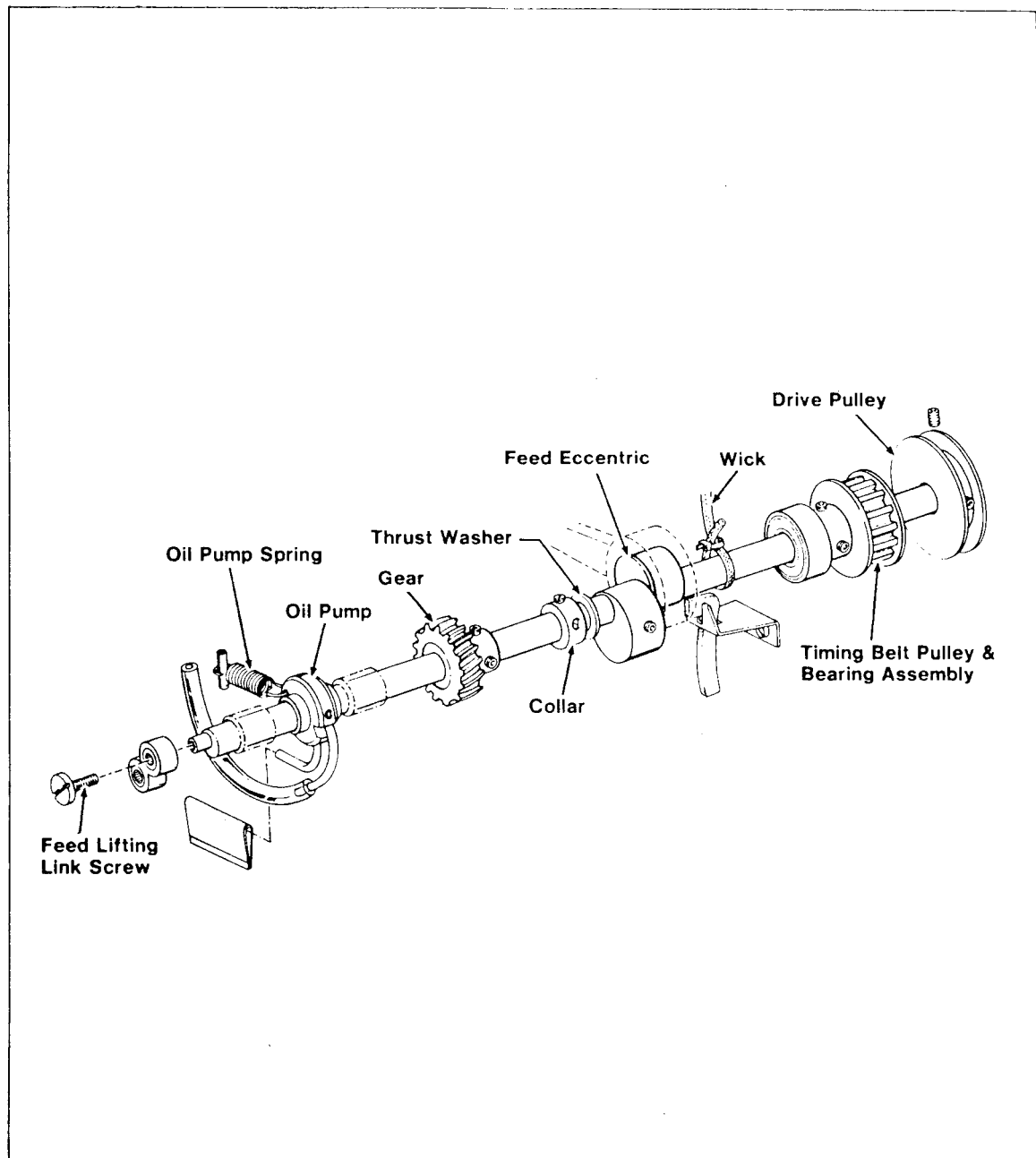

ASSEMBLY SEQUENCE

HOOK SHAFT AND HOOK SHAFT BUSHING

1. Insert hook shaft through bushing with collar **A** inside bushing until shaft position groove aligns with bearing face **C**. Tighten collar **A** set screws.
2. Replace gear, eliminate end play and tighten set screws onto flats.
3. Replace complete assembly into machine ensuring set screws aligns with flat on bushing. Replace plastic tube.

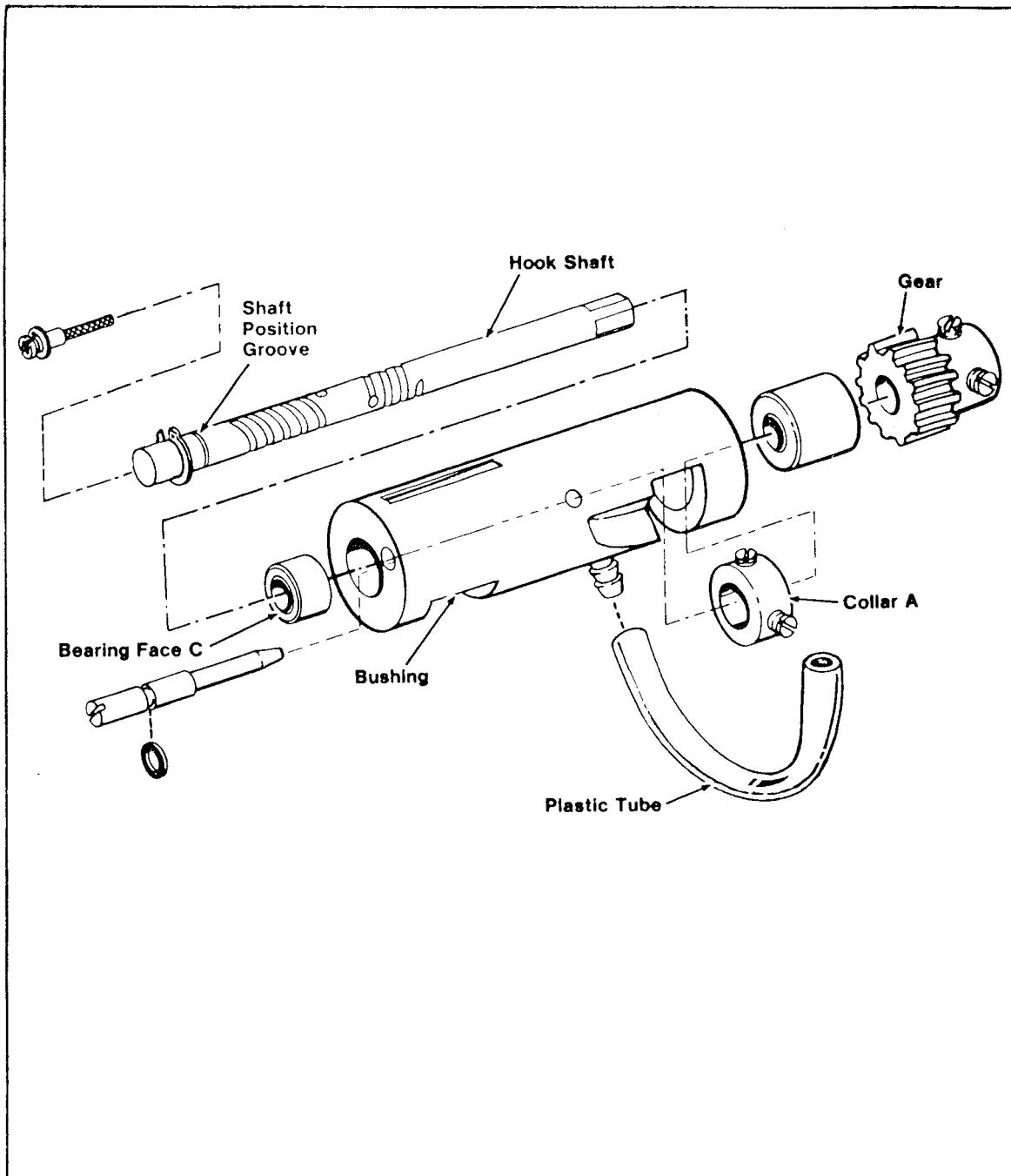

ASSEMBLY SEQUENCE

KNEE LIFT MECHANISM

1. Position horizontal shaft, thrust washer, collar and vertical link connecting arm inside arm casting as shown. Locate collar and connecting arm against inside walls of arm casting to retain shaft axially except for .005" - .015" end play.
2. Assemble vertical link to connecting arm with "E" ring. Note the letter "T" at one end of the link. This is the end to be connected.
3. Locate arm and pivot pin inside bed casting.
4. Insert horizontal link through two clearance holes in bed casting (with rubber seal) and screw into pivot pin. Insert rubber seal into first clearance hole.
5. Mount bell crank and bracket assembly to bed casting with two screws. Connect both horizontal and vertical links to bell crank assembly with "E" rings.
6. Mount knee lifter stop arm, spring and drum assembly to bed casting with threaded stud, long point set screw, washer and hex nut.
7. Insert knee lifter rock shaft (having two oil seals) into bed casting with horizontal link connecting arm, collar, sleeve and stop arm mounted to it as shown. Slide sleeve toward front end of rock shaft and lock in place with collar.
8. Mount spring clip to bed casting with washer and screw. Position spring clip in groove of extension bar. Rock shaft is adjustable axially to do this.
9. Insert knee lift extension bar assembly into rock shaft.
10. Lock rock shaft in place with set screw located in bed casting. Position stop arm and horizontal link connecting arm properly and lock in place.
11. Assemble eccentric cam stud to bed casting and fasten with washer and hex nut.

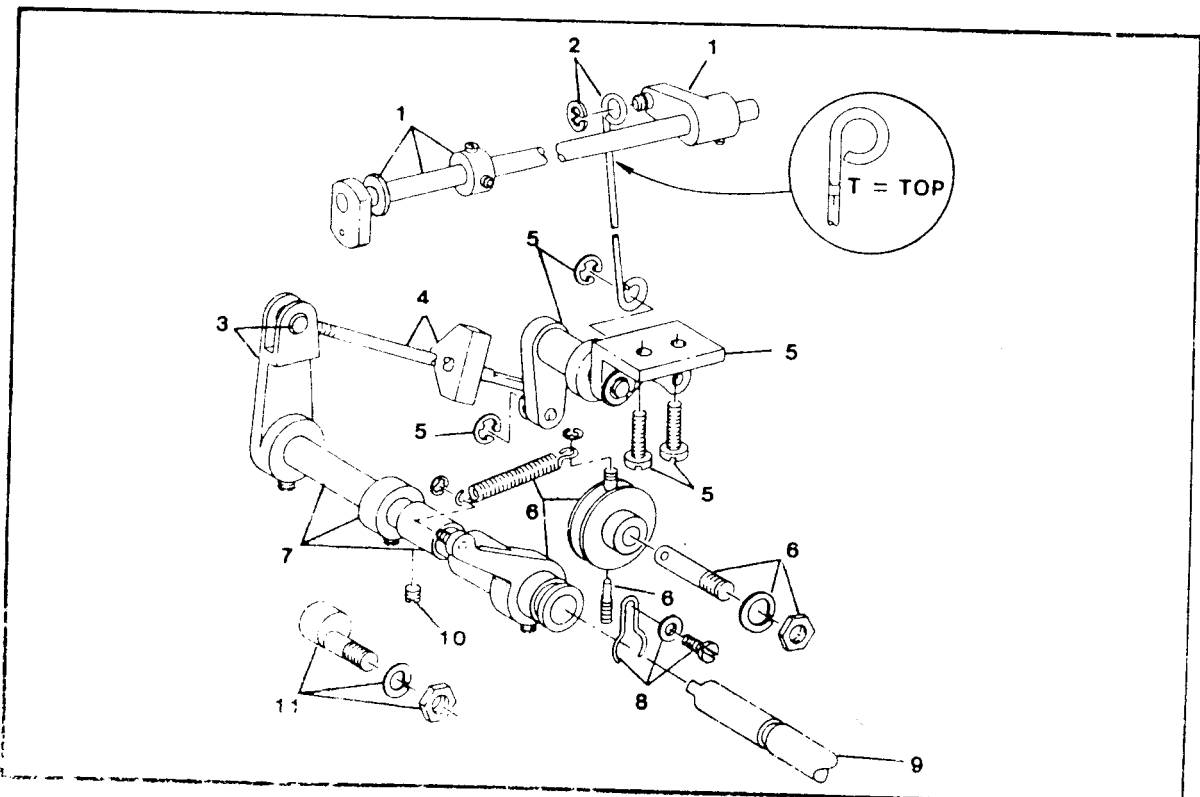

ASSEMBLY SEQUENCE

ARM SHAFT

1. Insert arm shaft from left to right into arm casting with counterweight, intermediate bearing assembly, bobbin winder drive wheel and timing belt pulley mounted to it as shown. Make sure arrow on counterweight is in direction of normal rotation.
2. With soft-faced mallet, lightly tap arm shaft from left to right until front arm shaft bearing is properly seated in casting.
3. Tighten set screws in intermediate bearing.
4. Rotate shaft to expose flats and position counterweight with set screw marked (S) over flat. Tighten set screw and tighten other set screw.
5. Align first set screw in direction of normal machine rotation and timing belt pulley over flat. Tighten same. Tighten other set screw.
6. Position bobbin winder drive wheel and tighten set screws.
7. Assemble timing belt and hand wheel. Tighten all remaining set screws.

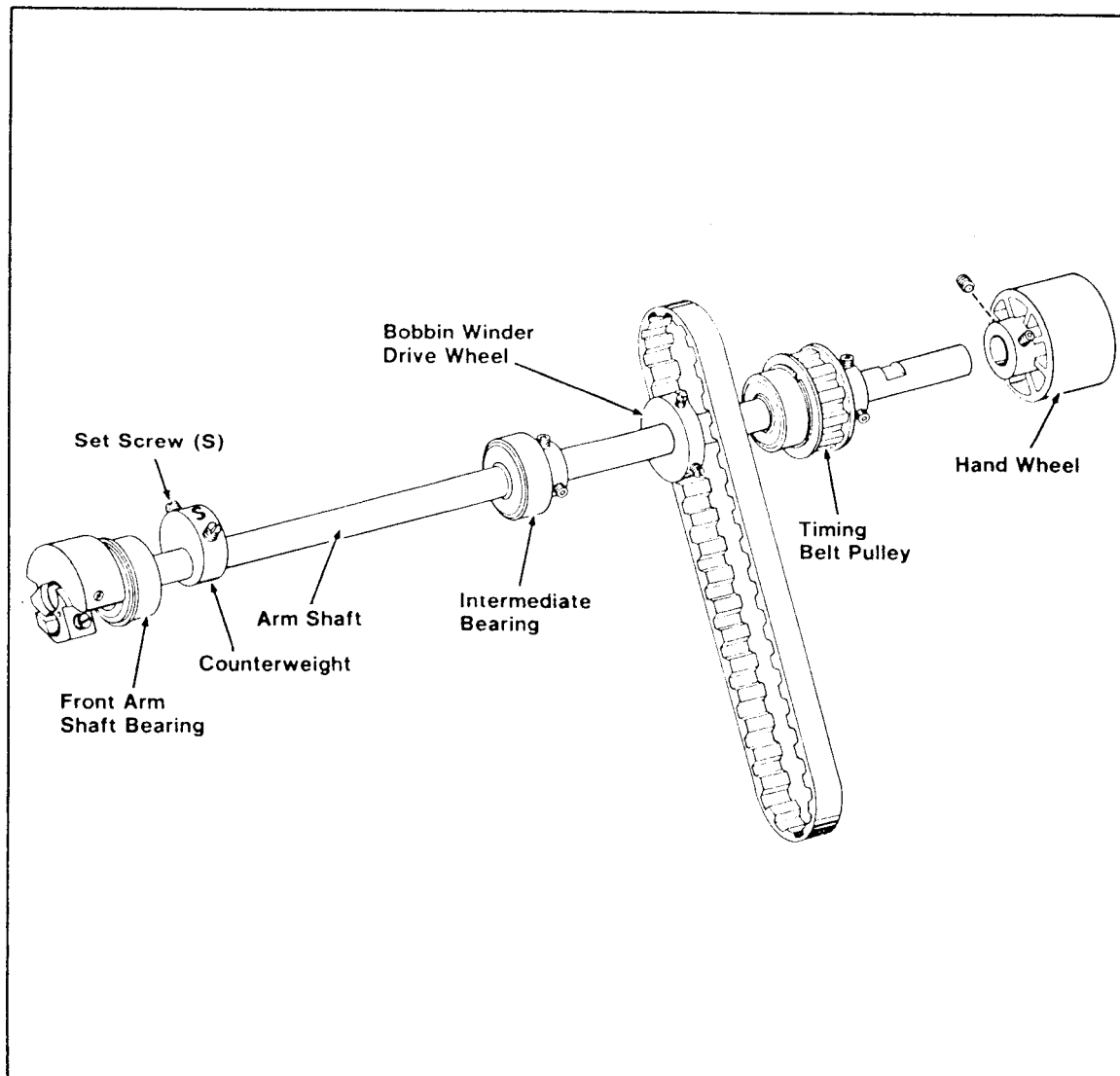

ASSEMBLY SEQUENCE

TENSION RELEASE MECHANISM

1. Insert tension releasing pin.
2. Replace hand lifting lever and mounting screw.
3. Replace tension releasing lever with spring in place.
4. Insert mounting screw and tighten.
5. Replace presser bar pressure lever adjusting screw tension clip and screw.
6. Replace lifting link and screw.

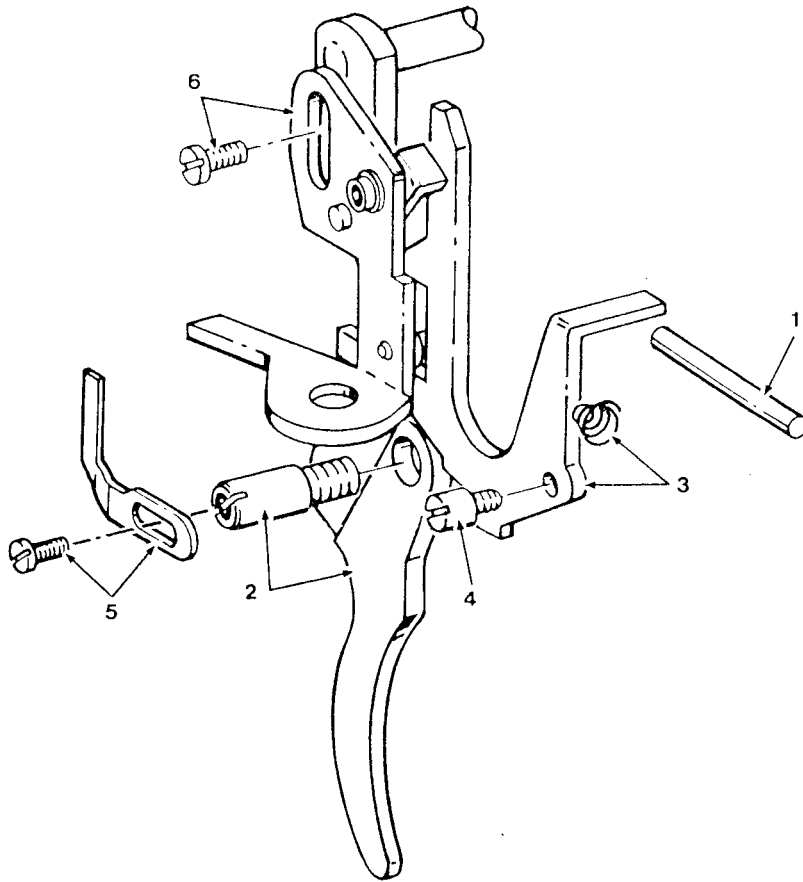

ASSEMBLY SEQUENCE

NEEDLE BAR FRAME AND THREAD TAKE-UP MECHANISM

1. Mount and fasten throat plate to bed casting.
2. Take complete unit, as shown in Fig. A, and insert into arm casting with studs No. 1, 2 and 3 entering simultaneously. Make certain that the slotted portion of the needle bar crank spacer, on stud No. 3, aligns with pin in counterbalance. Flats on all studs must be positioned relative to its locking set screws.
3. Locate frame and take-up unit so as to have the sewing needle positioned dead center into the throat plate needle hole. Lock studs No. 1 and 2 in place with set screws provided.
4. Insert thread take-up hinge stud, with flats facing upward, through take-up mechanism into arm casting and lock in place with both set screws. Replace thread guide.
5. Snug needle bar crank set screw on flat and snug needle bar crank pinch screw. Loosen set screw. Tighten pinch screw and set screw in that order.
6. Insert oiling wick through hole in casting, through felt pad, back through hole in casting into take-up stud. See FIG. B.
7. Wrap sucker wick around presser bar bushing, behind needle bar frame, around front of frame and between presser bar bushing and side of needle bar frame. See FIG. B.

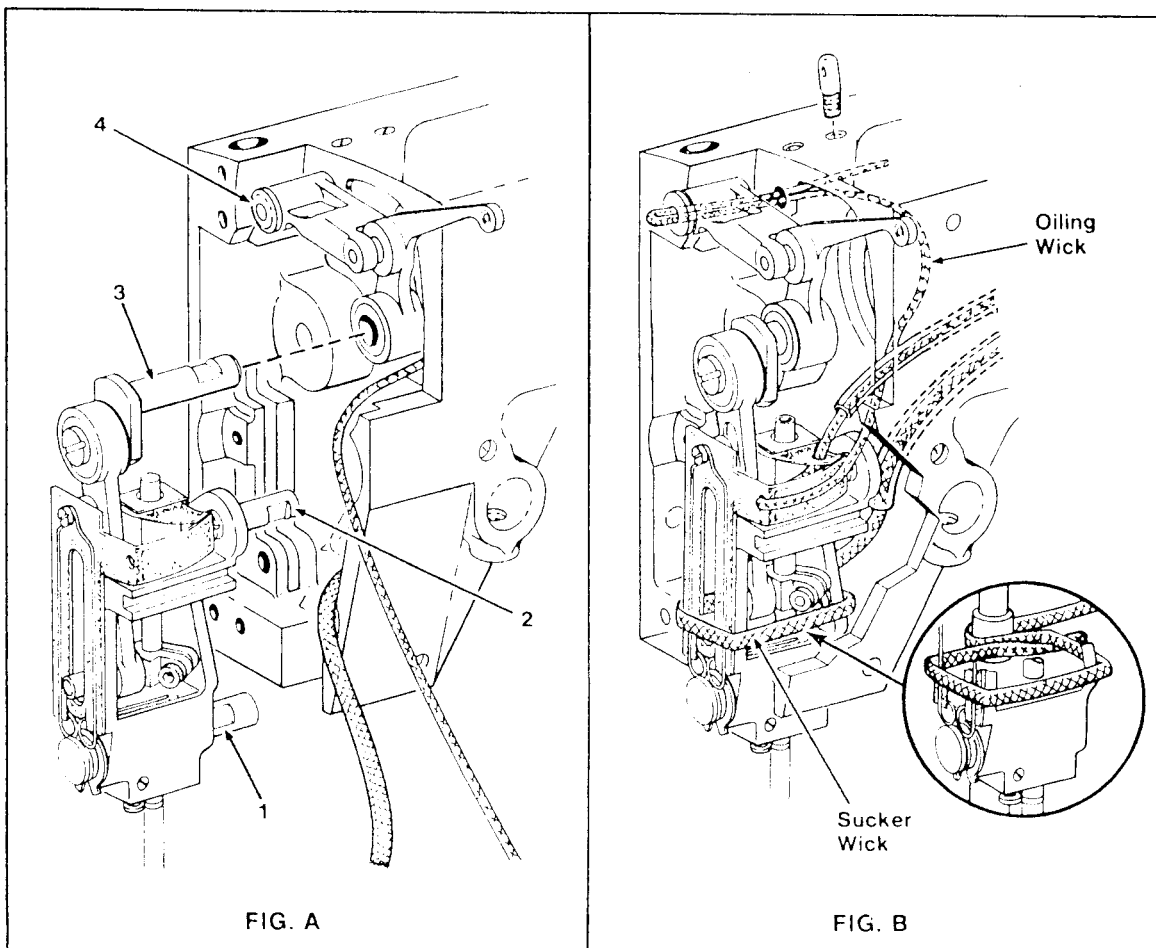

ASSEMBLY SEQUENCE

PRESSER BAR ASSEMBLY

1. Rotate hand wheel until take-up mechanism is out of presser bar removal path. Insert presser bar into presser bar bushing from top.
2. Assemble presser foot with screw shown.
3. Slide delrin spacer over presser bar.
4. Mount guide bracket and screw, (see page 15 for setting).
5. Mount spring and guide.
6. Assemble presser bar pressure lever adjusting screw.
7. Mount pressure lever with shoulder screw.
8. Assemble rod, washer, spring, steel ball and regulating screw.
9. Assemble face plate washers.
10. Assemble face plate and thread take-up lever guard complete.
11. Insert and tighten face plate mounting screws.

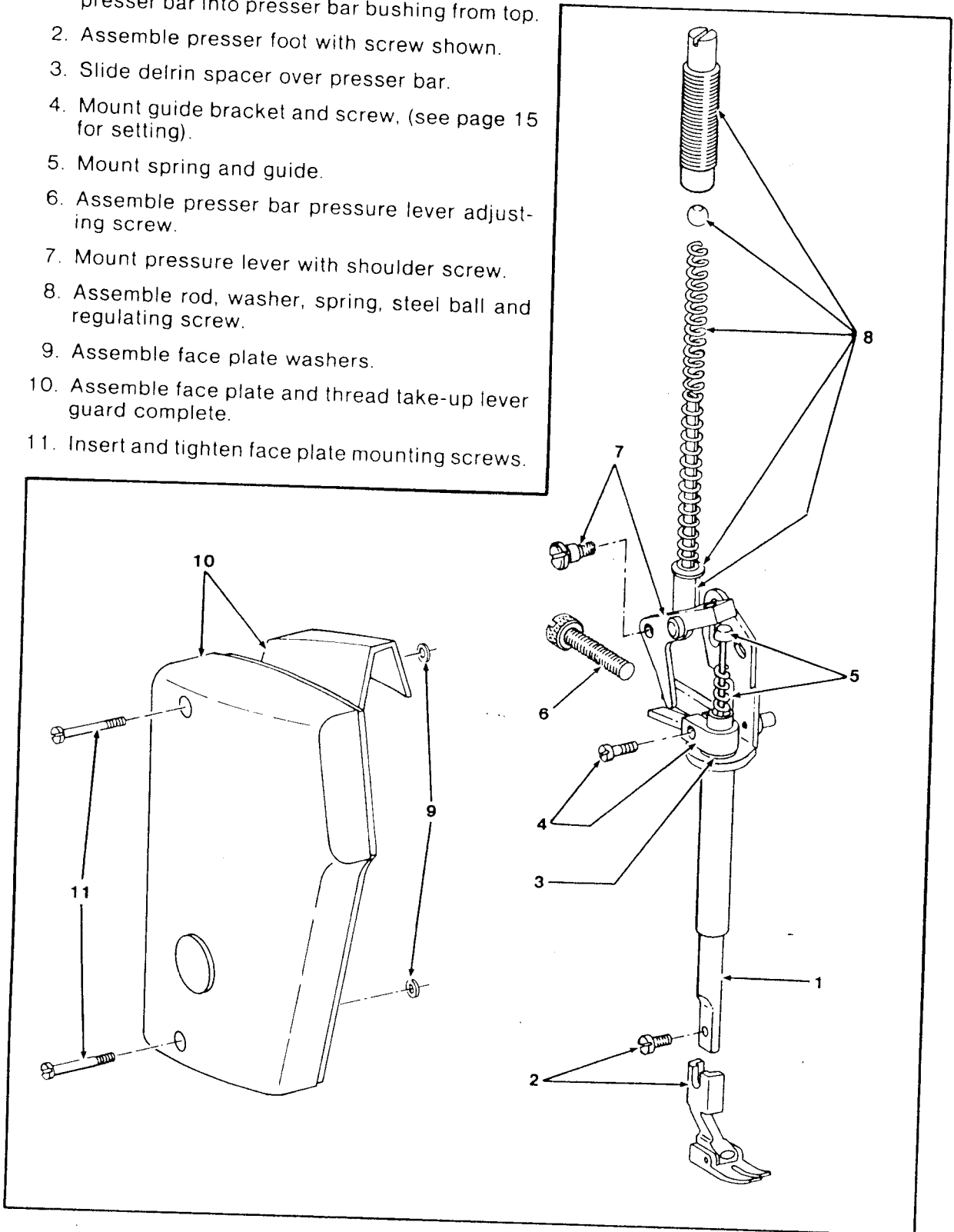



**SERVICE INSTRUCTIONS
FOR COMPOUND FEED SYSTEM**

121C CLASS

Servicing instructions for 121D Class machines also apply to the 121C Class with the exception of the following special instructions.

NEEDLE BAR FRAME DRIVING LINKAGE ADJUSTMENTS

1. Loosen pinch screws A, B and C.
2. Set connecting rod slide block to $3/32$ inch dimension, Fig. 1, and tighten pinch screw "A".
3. Set stitch length to zero stitches per inch in forward feed direction as shown on page 5.
4. Position connecting rod slide block stud perpendicular, (90°), to machined surface of arm casting, Fig. 1, and tighten pinch screw "C".

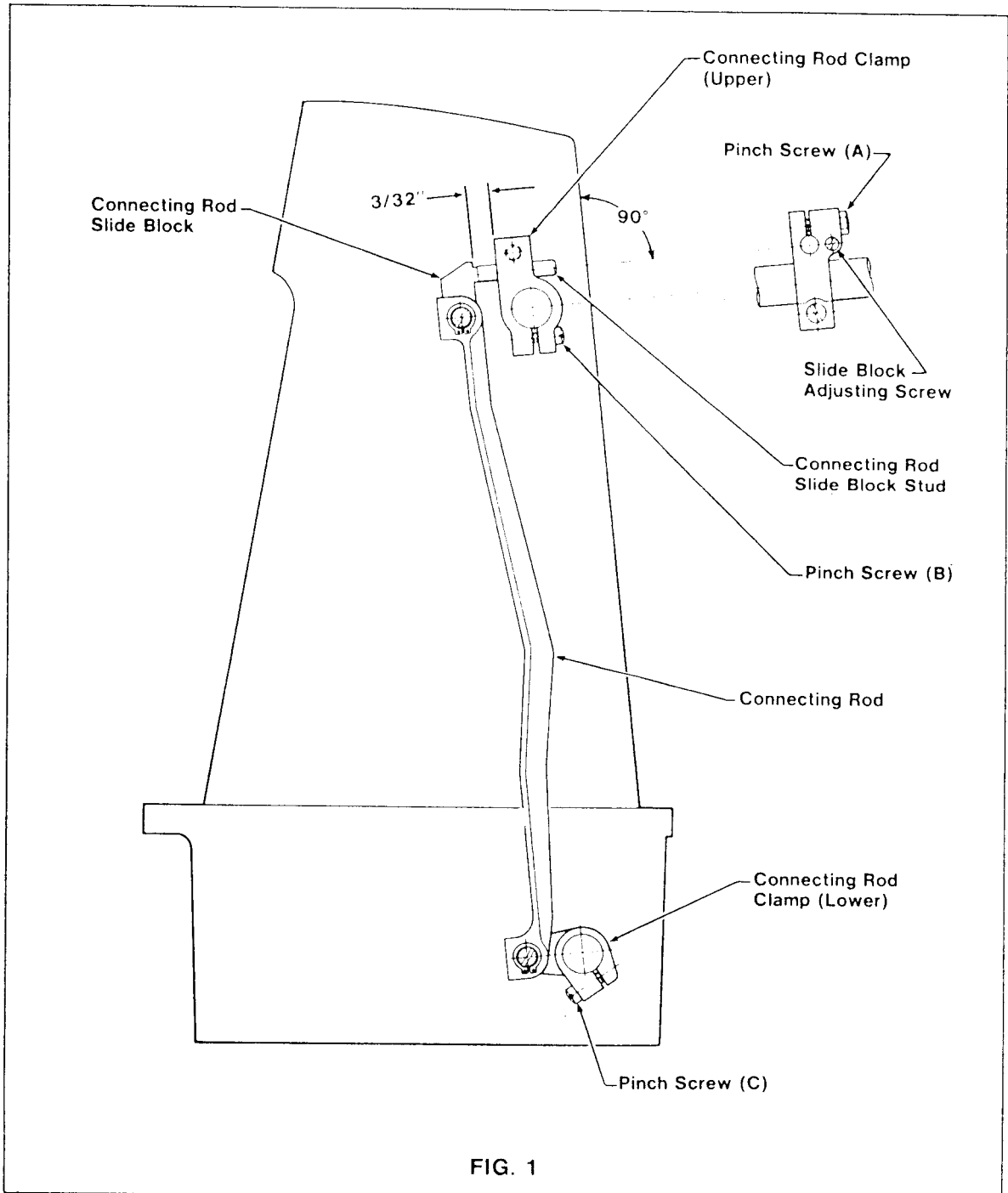
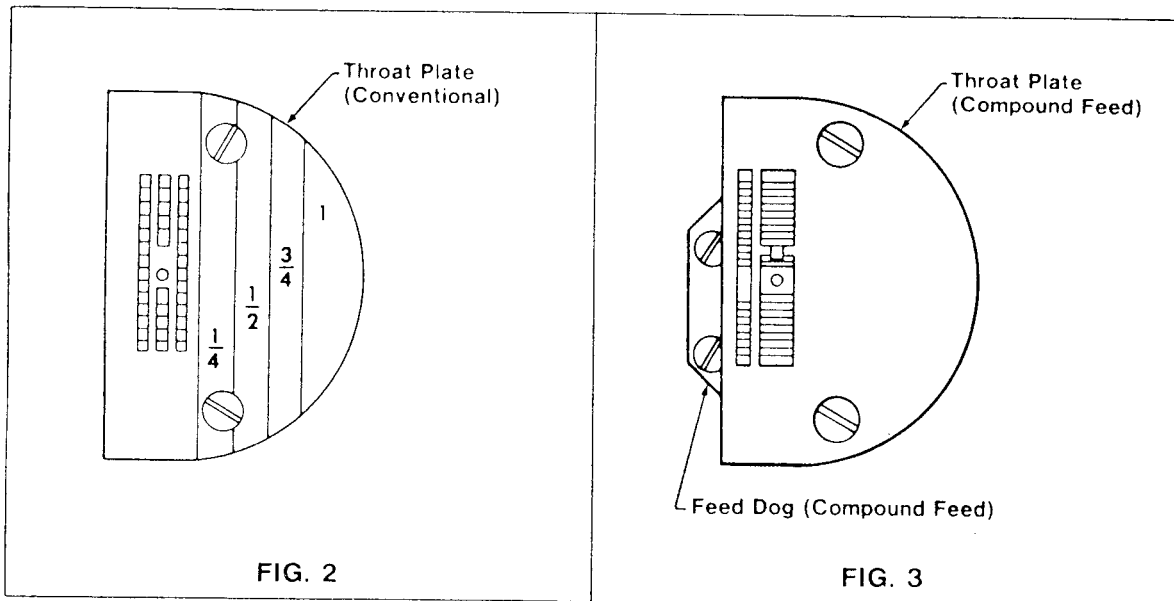

FIG. 1

NEEDLE BAR FRAME DRIVING LINKAGE ADJUSTMENTS CONT'D

5. Remove compound feed fittings (throat plate and feed dog), and replace with conventional throat plate (with needle hole) Fig. 2.
6. Position needle bar frame assembly to center needle into hole of throat plate and tighten pinch screw "B".
7. Replace conventional throat plate with compound feed fittings, (throat plate and feed dog) Fig. 3.



8. Set feed dog as shown on pages 10 and 11 with one exception. "Lengthwise Setting". In this case, set machine at zero stitches per inch and position feed dog needle hole central with needle. Then proceed with balance of "Lengthwise Setting".
9. Set stitch length to 14 stitches per inch in both forward and reverse feed direction.
10. Manually rotate hand wheel slowly. Try to centralize needle into feed dog hole in both maximum forward and maximum reverse feed direction. If not central, loosen pinch screw "A" and rotate slide block adjusting screw clockwise as desired and retighten pinch screw "A". Repeat as often as required to centralize needle into feed dog hole.

DISASSEMBLY SEQUENCE

1. Remove plastic cover mounting screws.
2. Remove plastic cover and gasket lining complete.
3. Remove six bed cover mounting screws.
4. Remove bed cover, gasket, sucker wick holder, sucker wick and stitch regulating knob complete.

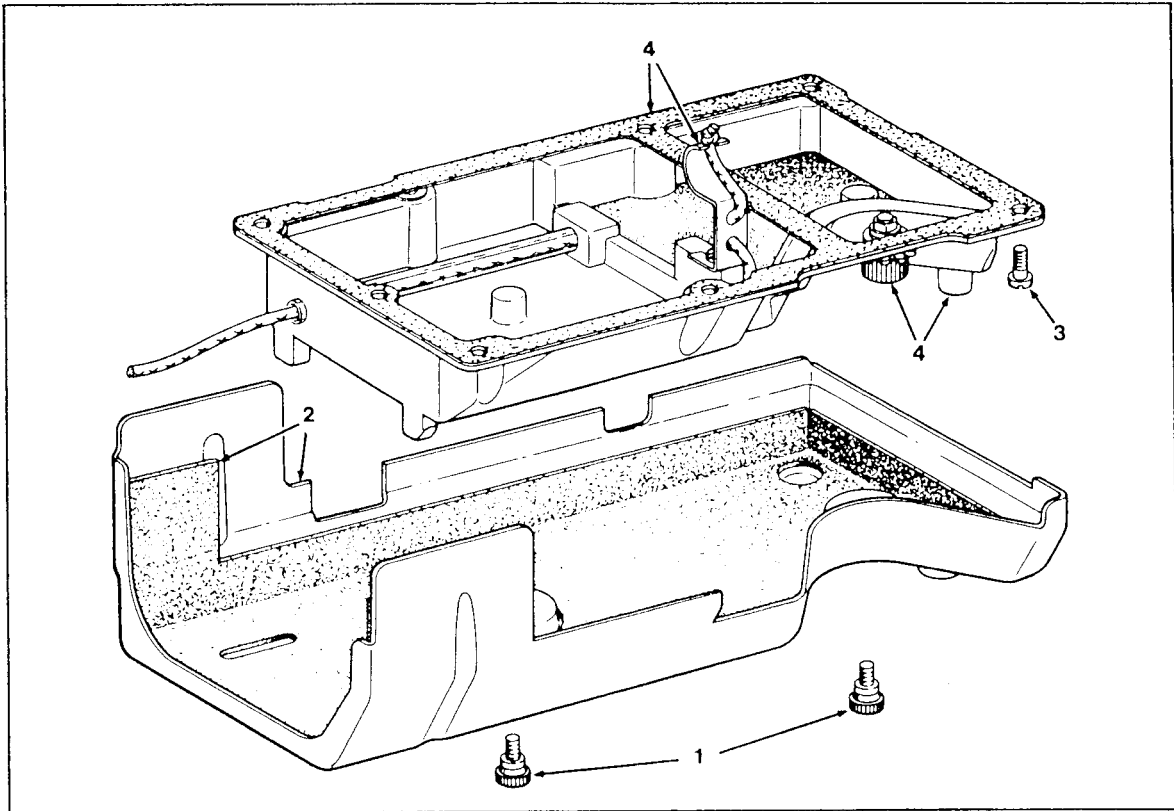

5. Loosen thread tension screw and remove tension assembly with releasing pin.
6. Remove thread take-up lever guard and thread guide complete. Remove pretensioner if assembled.
7. Remove face plate assembly and presser bar system as shown on page 19, with one exception. **Do not remove item 11 (presser bar pressure lever adjusting screw).**
8. Remove rear arm back cover, gasket, needle, oiling wick and sucker wick as shown on page 20.
9. Remove lifting link screw with link assembly, tension releasing lever mounting screw, lever and spring as shown on page 22 as items 1 and 3.

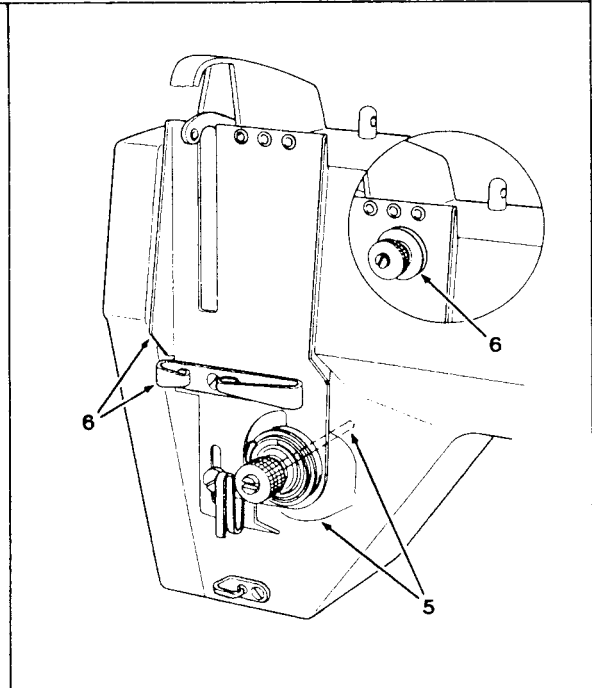

DISASSEMBLY SEQUENCE CONT'D

10. Remove throat plate and feed dog (not shown).
11. Loosen set screws in collar and crank.
12. Remove presser bar lifting shaft, spacer and collar.
13. Remove needle bar frame drive link retaining ring.
14. Remove needle bar frame and take-up mechanism as shown on page 21.
15. Loosen both pinch screws in connecting rod clamp (upper) and remove wicking.
16. Loosen set screws in collar.
17. Remove crank shaft assembly, collar and connecting rod clamp (upper).
18. Untie knot on wicking end, and remove from connecting rod.
19. Move feed rock shaft from right to left, as shown on page 24, with one exception. Do not remove shaft. Move it enough to clear lower connecting rod clamp. Please note that the right side collar on the compound feed machine is located near the feed bar carrier.
20. Remove connecting rod, connecting rod slide block and connecting rod clamp (lower) complete.

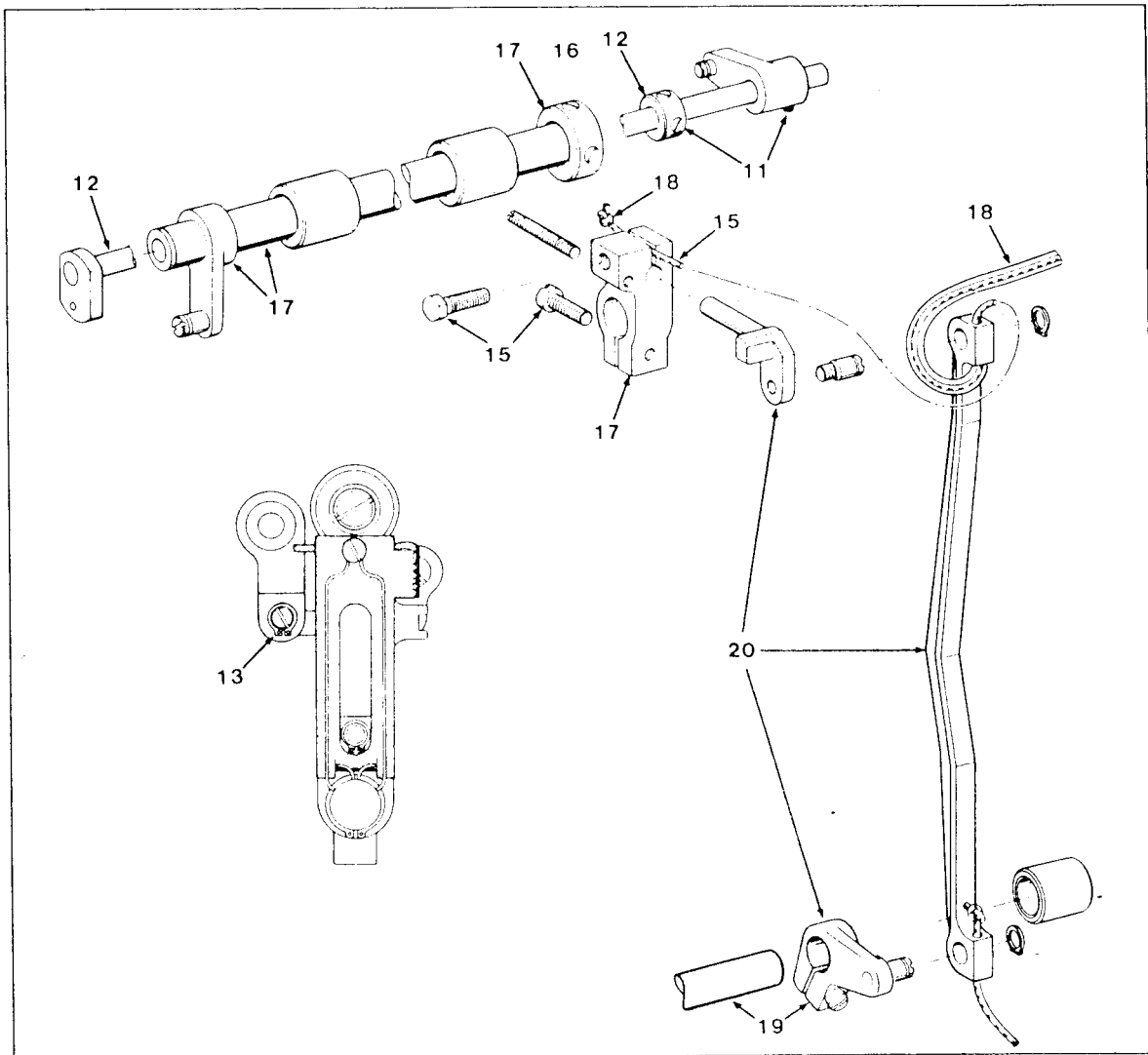

ASSEMBLY SEQUENCE

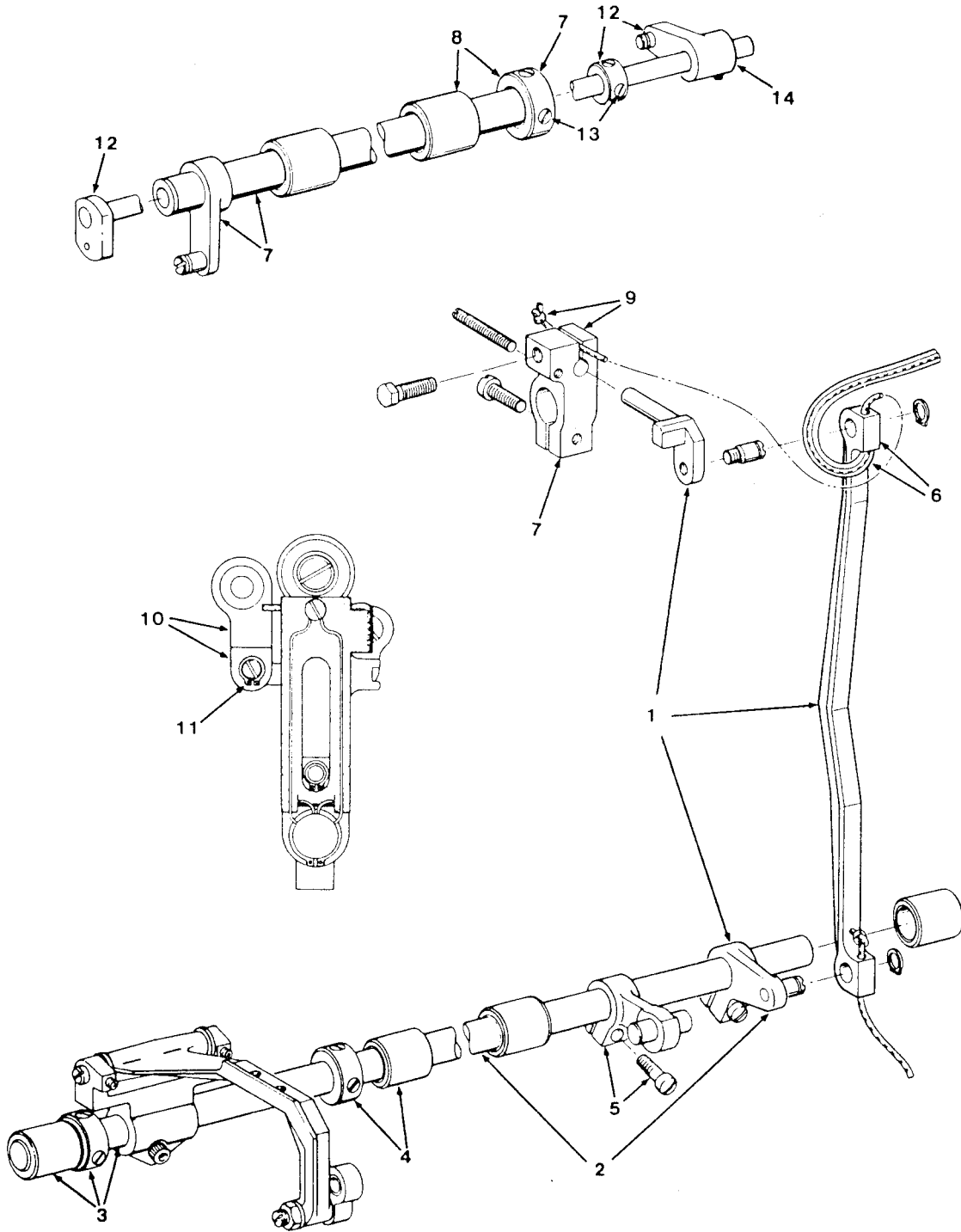

ASSEMBLY SEQUENCE

1. Insert connecting rod, slide block and lower clamp assembly into arm and bed casting.
2. Move feed rock shaft from left to right through lower connecting rod clamp assembly.
3. Set shaft end flush with left bearing face. Move collar up to bearing and tighten set screws.
4. Move second collar up to bearing shown, to allow .001 inch maximum end play, and tighten set screws.
5. Set feed reversing lever and drive assembly (not shown) at neutral position (no feed). Tighten feed reversing crank pinch screw (shown).
6. Insert wicking through connecting rod as shown.
7. Install crank shaft arm, connecting rod upper clamp assembly and collar.
8. Bring collar up to bearing face to allow .001" maximum end play of crank shaft assembly and tighten set screws.
9. Knot end of wicking and place into pinched clamp as illustrated.
10. Install needle bar frame and thread take-up mechanism as shown on page 37 with two additions.
First - mount and fasten conventional throat plate (with needle hole).
Second - line up crank shaft stud with needle bar frame drive link as shown.
11. Assemble needle bar frame drive link retaining ring.
12. Assemble presser bar lifting shaft, collar and crank.
13. Bring collar up to crank shaft assembly to allow .002" maximum end play and tighten set screws.
14. Position crank set screws on flats provided and tighten.
15. Replace tension releasing lever, spring, mounting screw and lifting link assembly with screw as shown on page 36 as items 3 and 5.
16. Replace thread take-up lever guard and thread guide complete. Assemble pretensioner if required.
17. Replace thread tension assembly with releasing pin and tighten tension mounting screw.
18. Assemble presser bar system and face plate assembly as shown on page 38 with one exception. Item 6, presser bar pressure lever adjusting screw, has been premounted.

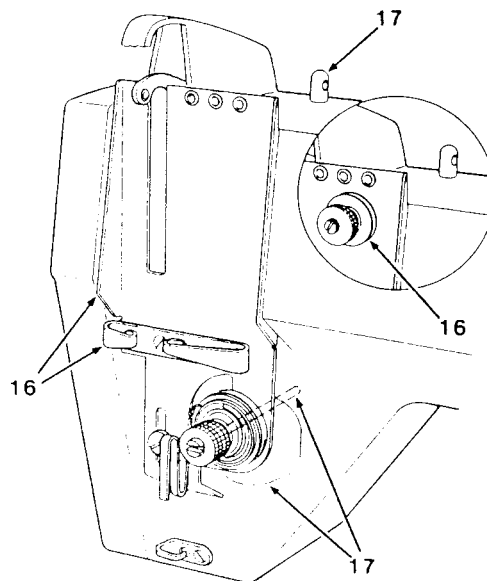

ASSEMBLY SEQUENCE CONT'D

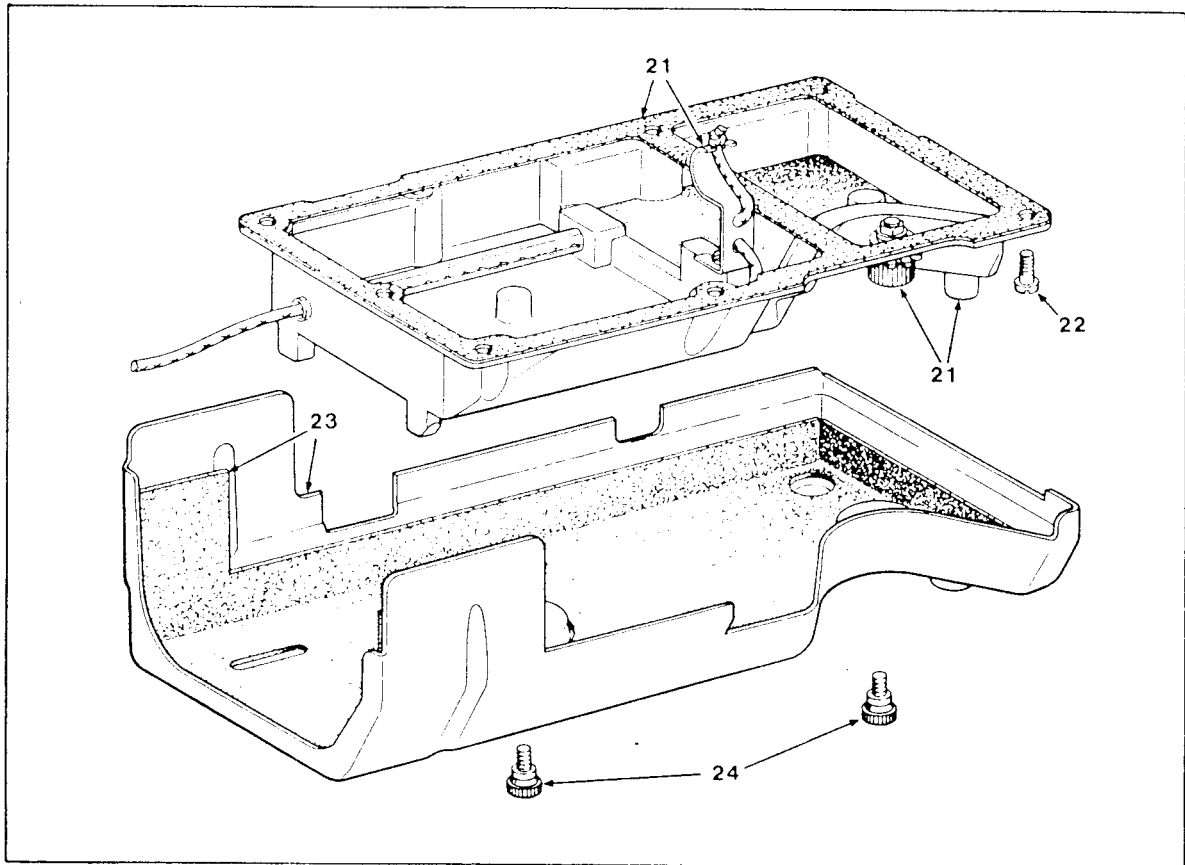

19. Set needle bar frame driving linkage to adjustments shown on page 40 and 41, steps 1 through 10. Please note that step 5 has been incorporated.
20. Assemble rear arm back cover and gasket. All are not illustrated.
21. Assemble bed cover, gasket sucker wick holder, sucker wick and stitch regulating knob complete. Please note that the sucker wick holder must be positioned under the rock shaft.
22. Insert six bed cover mounting screws and tighten.
23. Assemble plastic cover and gasket linking complete.
24. Insert two plastic cover mounting screws and tighten.