

JUKI®

Sewing Machine Controller SC-350

INSTRUCTION MANUAL

No.01
29296209

Congratulations on your purchase of a JUKI sewing machine controller.

To get the most out of many functions of the sewing machine controller, it is necessary to use the unit correctly, so please read this Instruction Manual carefully before using it. We hope you will enjoy using it for a long time.

BEFORE OPERATION

1. Never operate the machine unless its oil pan has been filled with oil.
2. Confirm that the voltage and phase (single- or 3-phase) are correct by checking them against the ratings shown on the PSC box nameplate located under the motor.
3. Be sure to connect the power supply earth wire to assure safety either for a single-phase or 3-phase version.
4. After setting up the machine, check the direction of motor rotation. To check it, turn the handwheel by hand to bring the needle down, and turn the power switch ON while observing the handwheel.
(The handwheel should turn counterclockwise as observed from the handwheel side.)

OPERATION PRECAUTIONS

1. Keep your hands away from the needle when you turn the power switch ON or while the machine is operating.
2. Do not put your fingers into the thread take-up cover while the machine is operating.
3. Be sure to turn the power switch OFF before tilting the machine head or removing the V belt.
4. While the sewing machine is in operation, be careful not to allow your or any other person's head or hands to come close to the handwheel, V belt, bobbin winder or motor.
Also, do not place anything close to them. Doing so may be dangerous.
5. If your machine is provided with a belt cover, finger guard or any other protectors, do not operate your machine with any of them removed.
6. To achieve security, be sure that the power supply earth wire has been connected before operating the sewing machine.
7. No motor sound is heard when the sewing machine is not operating. So, do not forget to turn the power OFF at the end of work.
8. When you move the unit from a cold place directly to a warm place, dew condensation may result. Turn ON the power to the unit after you have confirmed there is no fear of dew condensation.
9. In case of thunder, be sure to stop the unit and remove the power plug from the receptacle for extra safety.
10. Whenever you connect/remove the power connector or the like, be sure to turn OFF the power switch beforehand.

I. SET-UP

The following work should be carried out by a service man or a maintenance man.

1. INSTALLING THE MOTOR AND THE PSC BOX

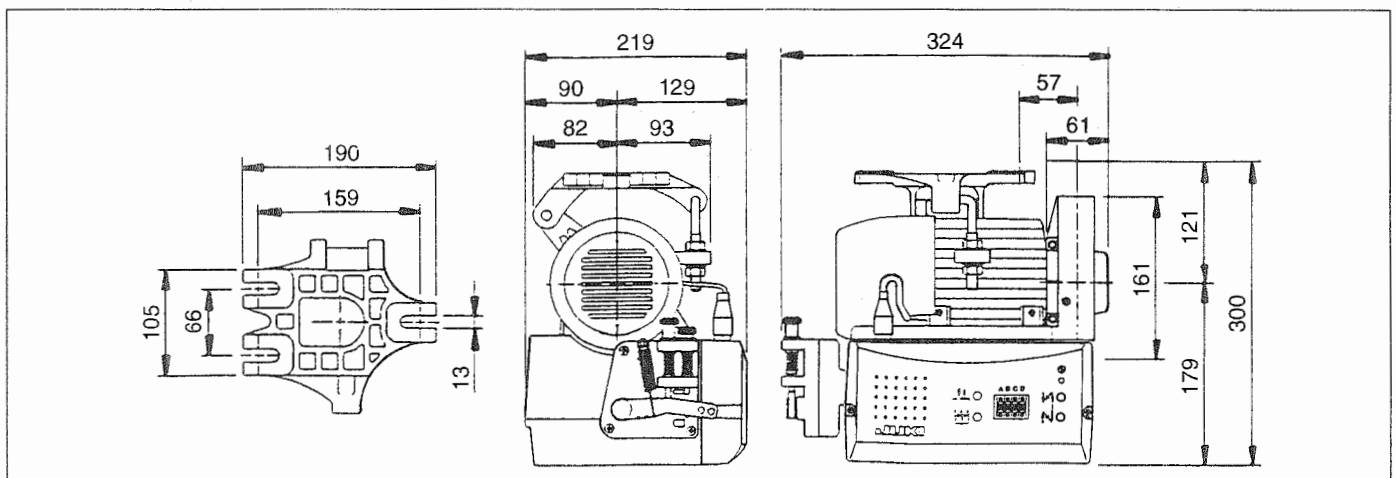

1) The external dimensions of the motor are shown in.

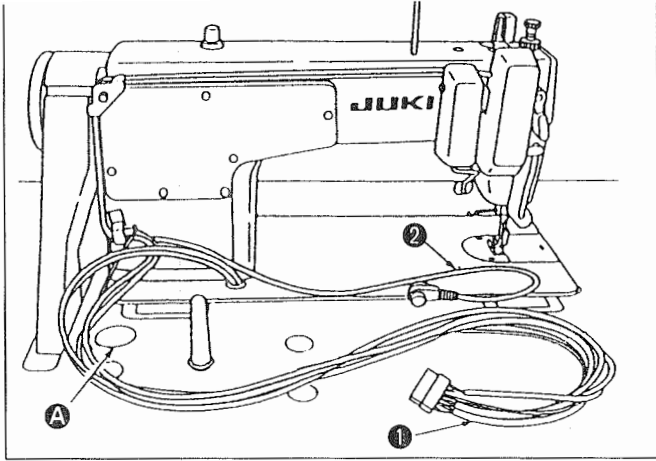

1) Pass cords ① of the thread trimming solenoid and reverse stitching solenoid, synchronizer cord ② coming from the machine head through hole ① in the table to route them down under the machine table.

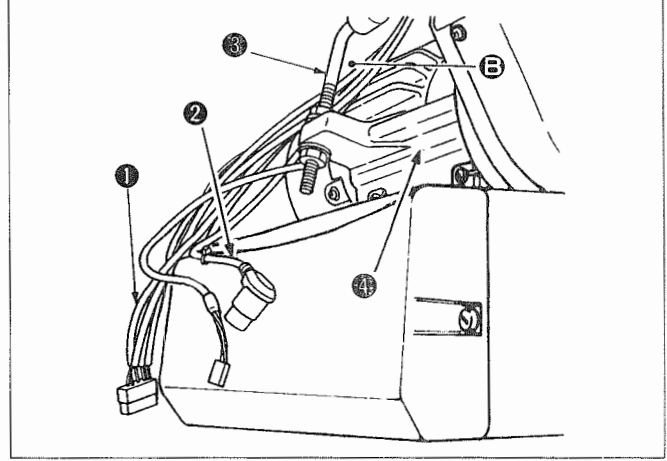

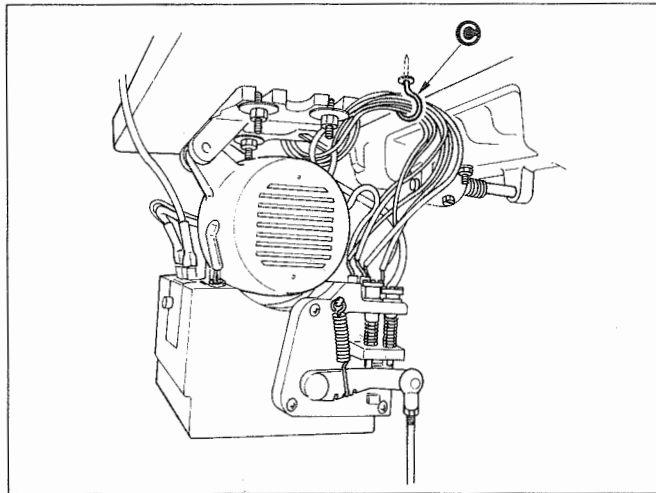

2) Pass cords ①, ② through section ③ located between belt tension adjust bolt ③ and motor ④, taking care not to allow the cords to come in contact with the belt.



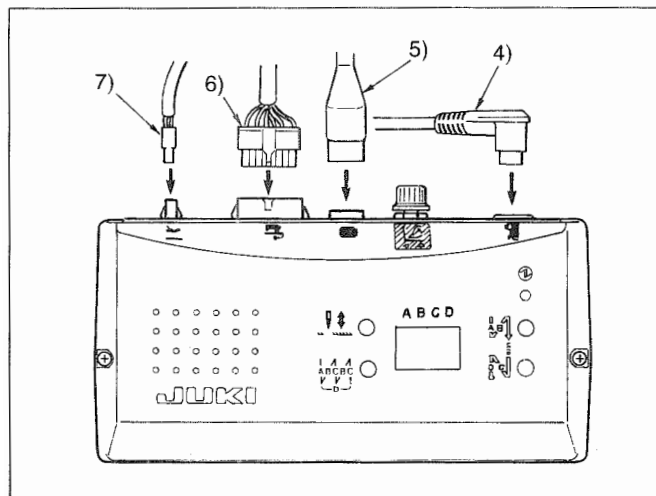

3) Fix the hook ③ supplied with the unit as an accessory on the lower surface of the table located above the top of the pedal connecting rod.



4) Connect the plug of the synchronizer cord to the control box connector marked as "  " on the front panel.
 5) Connect the 9P plug of the motor cord to the control box connector marked as "  " on the front panel.

**(NOTE) 1) To adjust the belt tension, be sure to detach this connector in prior.
 2) After the completion of the adjustment of the belt, be sure to re-connect the connector.**

6) Connect the 14P plug of the machine head cord to the control box connector marked as "  " on the front panel.
 7) Connect the 2P plug of the foot lifter cord to the control box connector marked as "  " on the front panel.

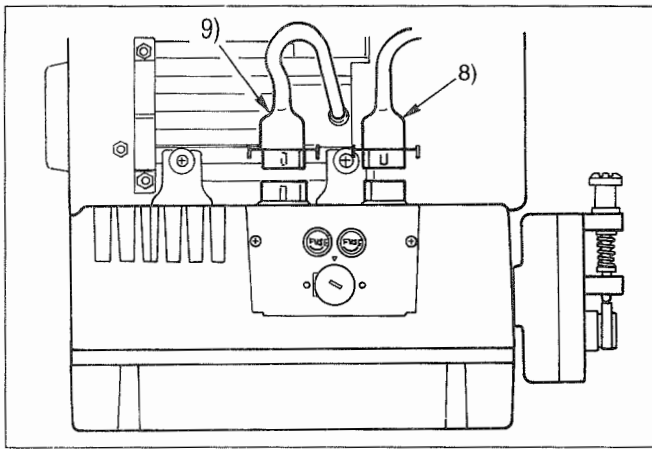

- 8) Connect the 4P plug of the power switch cord to the control box connector marked as "Power" on the back cover.
- 9) Connect the 4P plug of the motor cord to the control box connector on back cover.

(NOTE) The connected cords are not allowed to have any contact with the belt.

3. CHANGING OVER THE TRANSFORMER INPUT

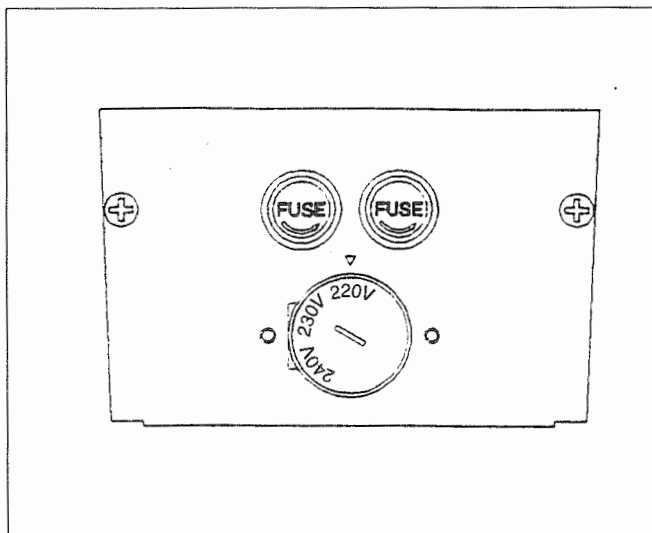

- (Caution)** 1. When changing over the input voltage of transformer, be sure to turn OFF the power to the unit.

Set the value shown on the dial of the voltage selected mounted on the rear face of the control box to the triangular pointer (▼) to provide the operating voltage.

4. HAND LAMP

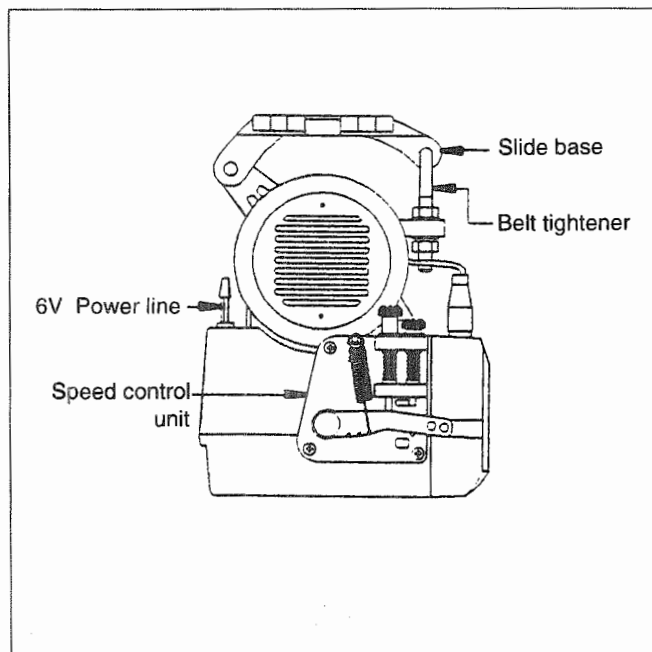

There is a 6V/15~20W AC power supply output for the voltage of the lamp to be used.

(Caution) Exercise care not to allow the cords of work lamps to short-circuit with each other.

1) Fix connecting rod ① to the hole ② of pedal lever ④ with nut ③.

2) Installing connecting rod ① to hole ⑤ will shorten the pedal depressing stroke. This means you can operate the pedal more quickly.

(Caution) To use hole ⑤, take care not to allow the screw in the connecting rod to appear above nut ③ as illustrated in the sketch.

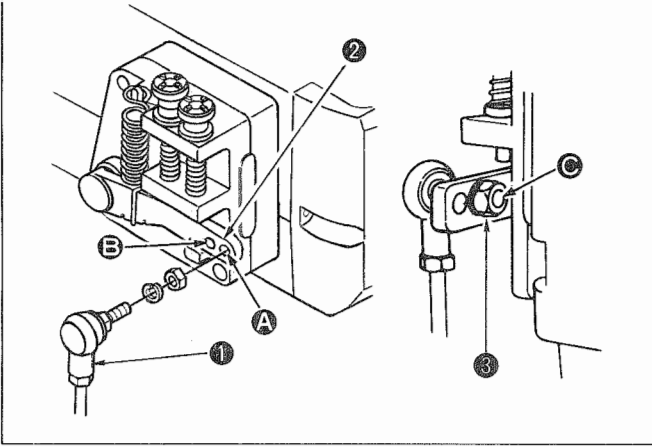

6. REPLACING THE POWER FUSE

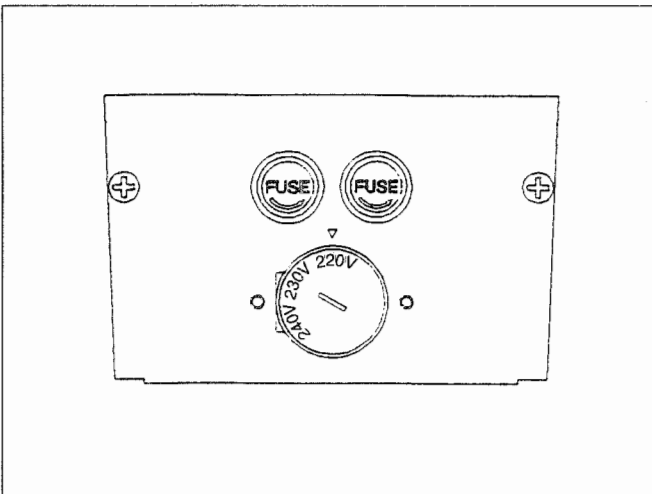

There are 2 fuse caps on the back cover. As to remove the cap is to turn the cap by hand along the direction of the arrow, to install the cap is to turn the cap along the opposite direction of arrow. The fuse capacity is 10A/250V.

(Caution) When replacing the fuse, be sure to turn OFF the power to the unit beforehand.

7. MOTOR

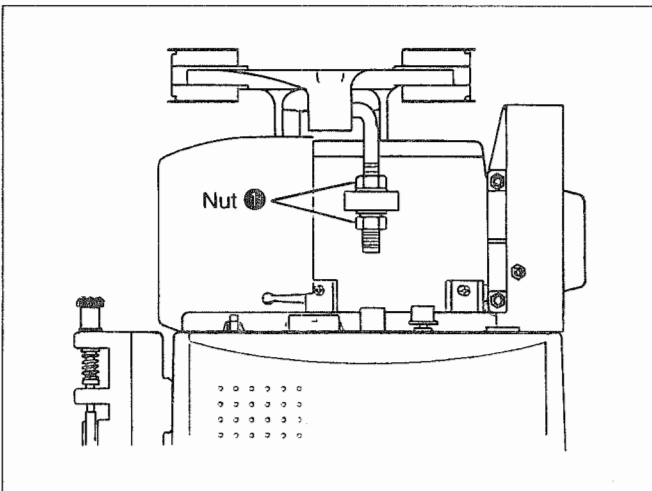

(1) Adjusting the belt tension

- 1) Adjust the belt tension by moving adjustment nut ① of the base retaining rod up or down.
- 2) The belt should slacken to such an extent that the center of the belt goes down as deep as 10 to 20 mm when you depress there by hand, which is used as reference when you adjust the belt tension. If the belt tension is inadequate, the belt may vibrate during sewing or the machine may fail to stop at the predetermined position.

(Caution) If you cannot adjust the belt tension to the desired value using adjustment nut ①, loosen the motor installation bolt and adjust the belt tension properly by moving the motor back or forth.

(2) Cleaning the motor

It is necessary to regularly eliminate thread waste or cloth chip accumulated in the PSC box and the air window motor housing on the pulley side from which the motor cooling air is sucked.

II. FOR THE OPERATOR

1. ADJUSTING THE MAXIMUM SEWING SPEED

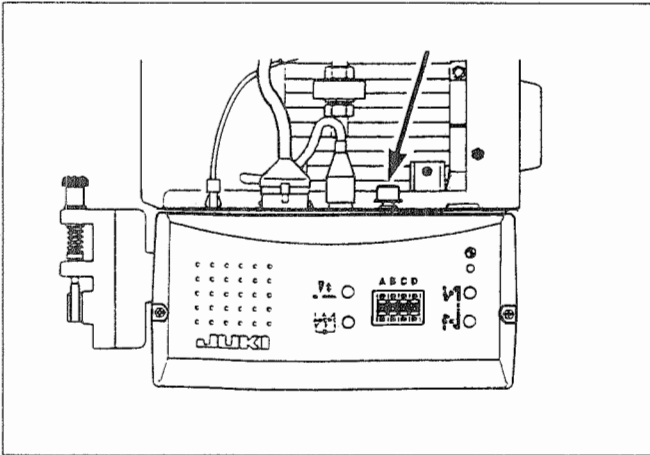

The max. sewing speed can be electrically limited. This machine is equipped with max. sewing speed control variable resistor which is used to limit the max. sewing speed. As you turn max. sewing speed control variable resistor counterclockwise, the maximum sewing speed will be limited.

2. EXPLANATION OF THE OPERATION SWITCHES AND OPERATION PROCEDURE

There are several functions that can be selected by the counters, push buttons on the front panel, a knob and the DIP switches inside the control box.

◇ The functions that can be determined by the counters, push buttons on the front panel are described as following.

1. The counter A indicates the stitch number of A_code.
2. The counter B indicates the stitch number of B_code.
3. The counter C indicates the stitch number of C_code.
4. The counter D indicates the stitch number of D_code.
5. The push button light AB indicates if the start tacking stitch is available or not. If the AB light is on, the start tacking is available.
6. The push button light CD indicates if the end tacking stitch is available or not. If the CD light is on, the end tacking is available.

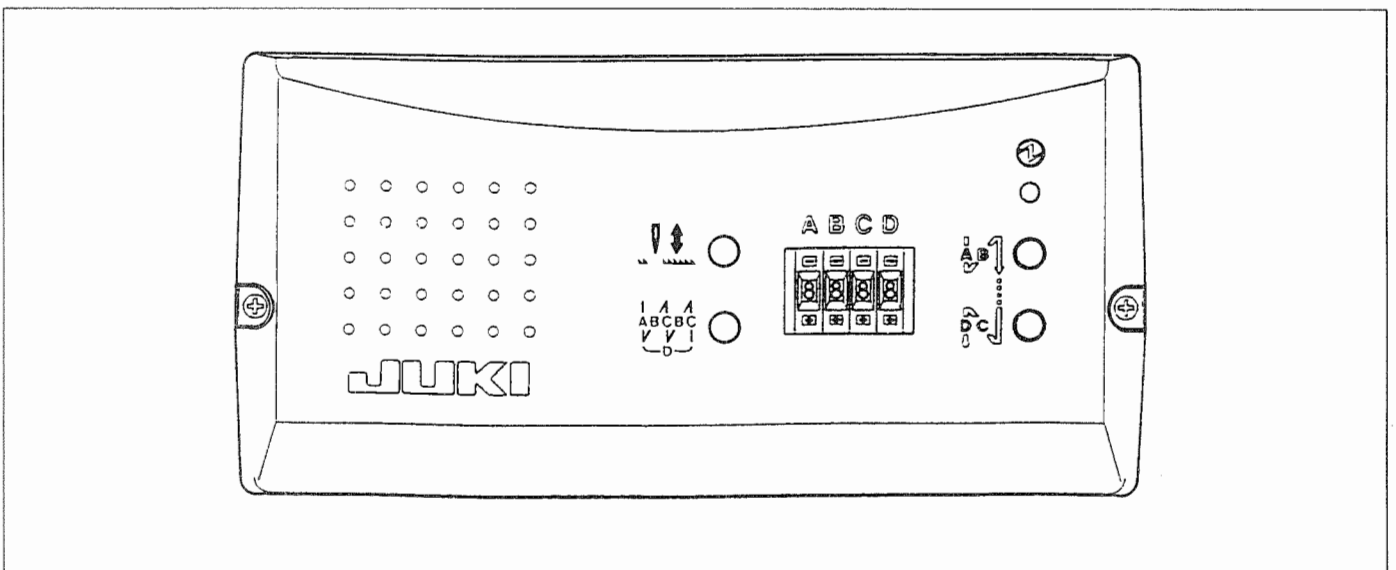

The unit is equipped with the following functions to permit easier sewing operation.
 Remove screws ① from the PSC box under the motor, open cover ②, and set each function, using the switches on main circuit board ③.

- (Caution) 1. Be sure to turn the power switch OFF before changing the setting of a switch.
 2. Do not tamper with any switches other than those allowed.
 3. Take care not to allow cover ② that has been removed to interfere with the DIP switches.
 (See the figure given below)

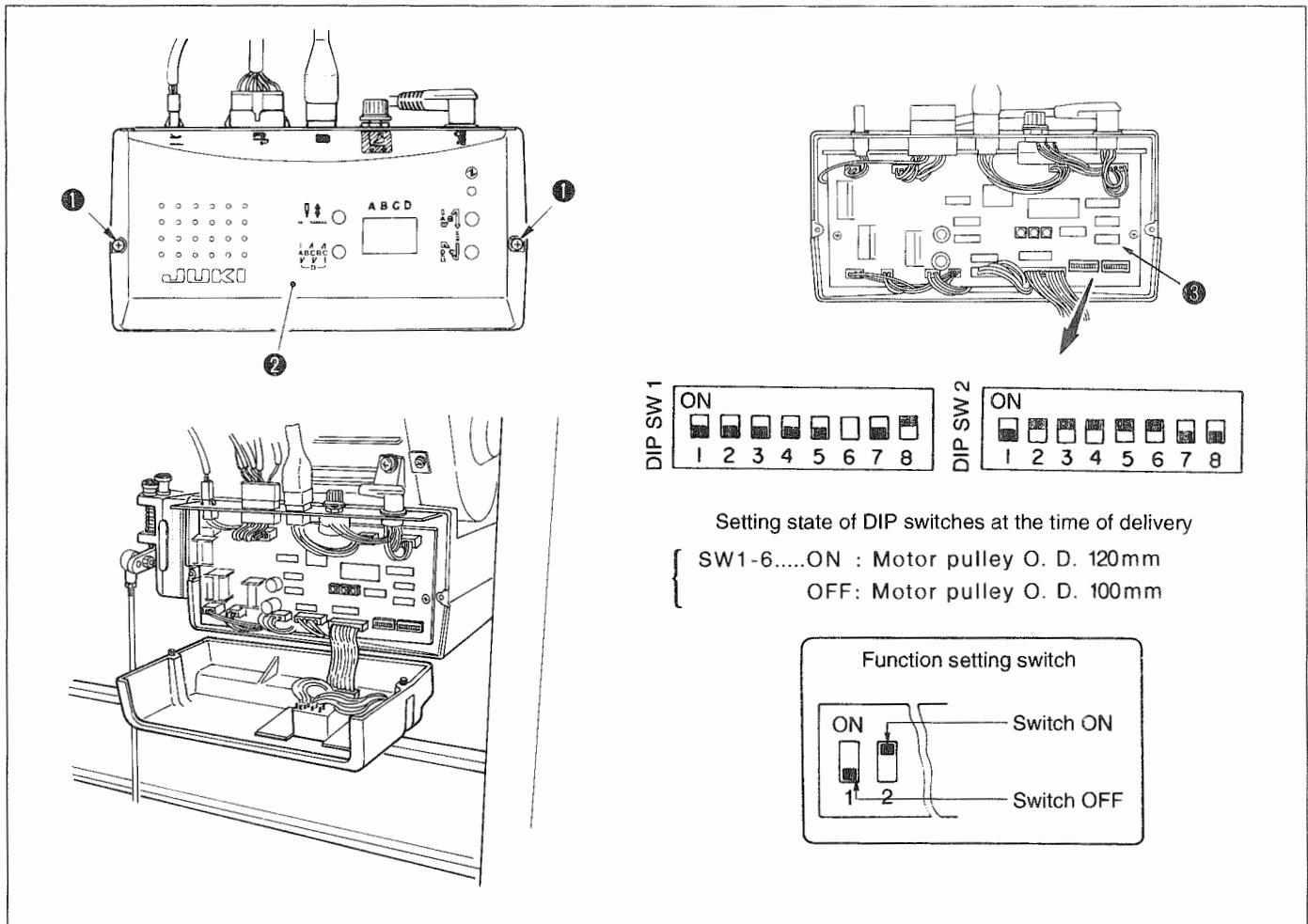

(1) Auto-lifter function

For a machine equipped with an Auto-lifter, be sure that the following switch in the PSC box has been set to ON.

SW1-7 ON

(2) Wiper function

For a machine head equipped with a wiper, be sure that the following switch has been set to ON.

SW1-8 ON

(Precaution) The switch on the wiper mounted on the machine head should be used to temporarily stop the wiper.

(3) Needle-up stop function

Normally, a sewing machine pauses with its needle down. By setting this switch ④ to ON (the LED lights up), you can make the machine stop with its needle up.

..... On for needle-up stop (OFF for needle-down stop)

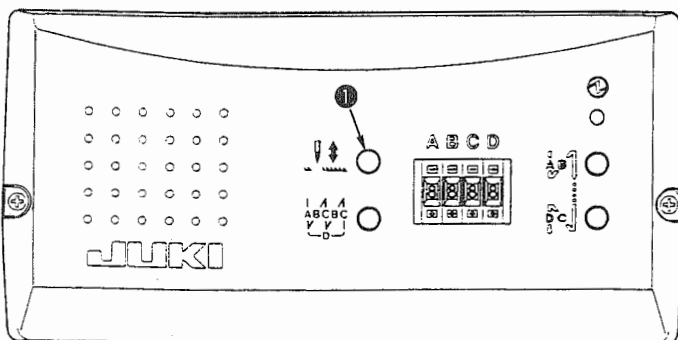

(4) Adjusting the automatic reverse feed stitching speed

Open the PSC box cover, and turn clockwise the cross slit at the center of variable resistor (VR2 MS) on the main circuit board to increase the speed or turn it counterclockwise to decrease the speed.

Normally, the reverse feed stitching speed is adjusted to 1,900 s.p.m. Using this variable resistor, you can change the speed within the range of 1,500 to 2,500 s.p.m. If you change the speed, however, overlapping reverse feed stitches may be misaligned with normal feed stitches under them.

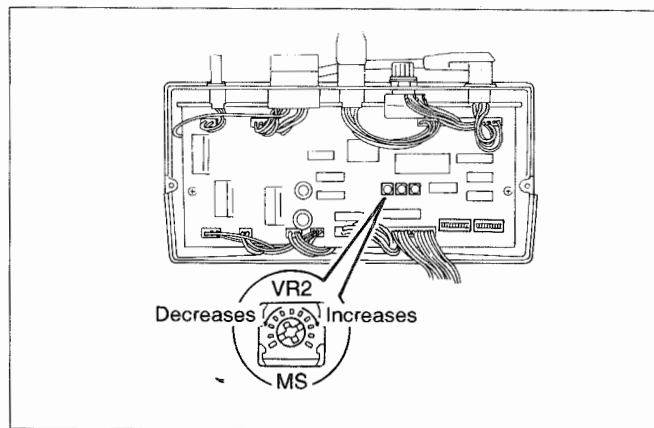

(5) Setting the soft-start function

If the needle thread may fail to interlace with the bobbin thread at the start of sewing when a smaller stitch length or a thicker needle is used, the sewing speed can be limited for two stitches at the sewing start, thereby improving consistency in the stitch formation at the sewing start.

SW1-5 ON

(6) Checking and correcting the direction of rotation

Turn the handwheel by hand to bring the needle down. Turn the power switch ON while observing the handwheel in order to check the direction of its rotation.

SW1-1 OFF : forward
ON : reverse

(7) Compensating the automatic reverse feed stitching

If the normal feed stitches and reverse feed stitches are not sewn with aligned under the reverse feed stitching mode, the stitches can be corrected by changing the timing of automatic reverse feed stitching. (Note that this function is effective only when the number of stitches specified for the respective processes is 3 or more.)

Reverse feed stitching for start

Reverse feed stitching for end

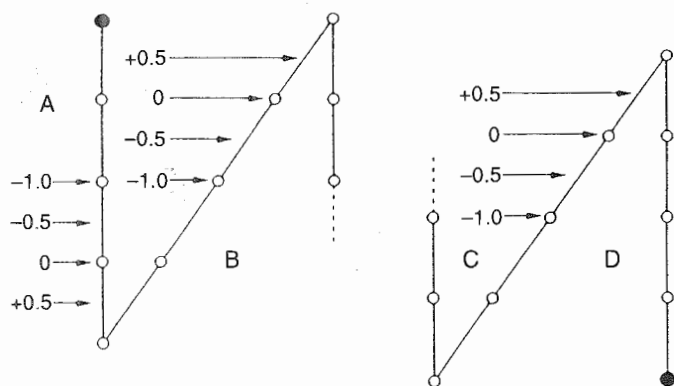

In case of "A = B = 4 stitches"

In case of "C = D = 4 stitches"

Compensating position	A		B		C	
	SW2 1	SW2 2	SW2 3	SW2 4	SW2 5	SW2 6
-1.0	×	×	×	×	×	×
-0.5	○	×	○	×	○	×
0	×	○	×	○	×	○
+0.5	○	○	○	○	○	○

Nota) The setting given in the heavy-line column () is the standard set value.

(7)-1 Compensating procedure:

For the reverse feed stitching for start, compensate first process A, then process B.

① Process A

- In case where the number of stitches for process A are properly finished, however, the stitch length of the first stitch for process B is insufficient or the needle enters the material at the same position twice when sewing the first stitch or the number of stitches for process A is larger than that for process B by one.
→ Set the compensating value to a negative value.
- In case where the number of stitches for process A cannot be properly finished.
→ Set the compensating value to a positive value.

② Process B

- In case where the stitch length of the last stitch for process B is insufficient or the needle enters the material at the same position twice when sewing the last stitch, or the number of stitches for process B is smaller than that for process A.
→ Set the compensating value to a positive value.
- In case where the number of stitches for process B is properly finished, however the stitch length of the first stitch for free stitching is insufficient or the needle enters the material at the same position twice when sewing the first stitch or the number of stitches for process B is larger than that for the free stitching process by one.

→ Set the compensating value to a negative value.

- In case where the number of stitches for process D is properly finished, however the stitch length of the last stitch for process C is insufficient or the needle enters the material at the same position twice when sewing the last stitch or the number of stitches for process D is larger than that for process C by one.

→ Set the compensating value to a positive value.

(8) Overlapped stitching pattern

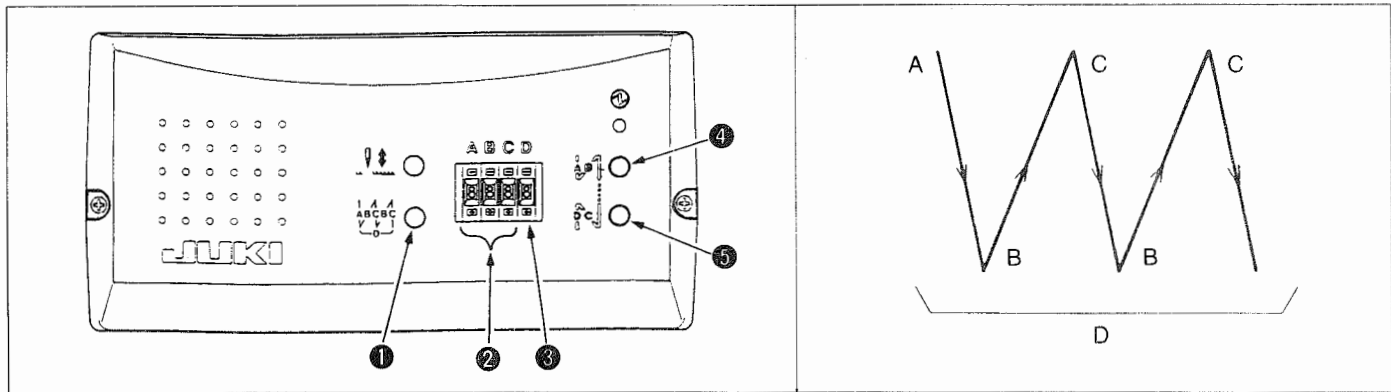

- Press overlapped stitching pattern switch ① to specify the overlapped stitching pattern
- If you want to change the number of stitches, operate the "+" or "-" switch of switches ② for setting the number of stitches for processes A through C. If you want to change the number of whole processes, operate the "+" or "-" switch of switch ③ for setting the number of processes D.
(The range of the number of stitches A, B and C that can be changed: 0 to 9 stitches) (The range of the number of processes D that can be changed: 0 to 9 times)
- Depress the front part of the pedal once, and the sewing machine will repeat the normal stitching and reverse stitching by the predetermined time. Then, the sewing machine will automatically make the thread trimmer actuate and will stop to complete the overlapped stitching procedure.

(Note) While overlapped stitching pattern switch ① is in the ON state (the LED lights up), the overlapped stitching pattern sewing performance is given priority even if SBT switch ④ and EBT switch ⑤ are in the ON state (LEDs light up).

4. SAFETY CIRCUITRY

The machine is so designed that its safety circuit works in the event that any of the following abnormal conditions arises.

(1) In the event that an abnormal load is applied to the machine

If the machine aborts when an abnormal load is applied to it, the safety circuit will work within approximately one or two seconds to cause the motor to stop running. Find a cause, take an appropriate corrective measure, then re-turn on the power to the machine to restore the normal operation.

(2) If a needle position detector has failed

Failure of the upper or lower needle stop position detecting function is automatically detected by the safety circuit. Then, the machine actuates as one with a clutch motor.

(3) In the event that an input power is abnormal

If the supply voltage drops to an excessively low value (decreases by 30 to 40%), the safety circuit works to cause the motor to stop running. Find a cause, take an appropriate corrective measure, and re-turn on the power to the machine to restore the normal operation.

JUKI®

JUKI CORPORATION
INTERNATIONAL SALES DIVISION
8-2-1, KOKURYO-CHO,
CHOFU-SHI, TOKYO 182, JAPAN
PHONE : 03 (3430) 4001~5
FAX : 03 (3430) 4909-4914-4984
TELEX : J22967

To order or for further information, please contact :

Please do not hesitate to contact our distributors or agents in your area for further information when necessary.
* The description covered in this instruction manual is subject to change for improvement of the commodity without notice.