

# JUKI

SUPER-HIGH-SPEED, 1-NEEDLE OVERLOCK MACHINE  
**MO-3904**  
SUPER-HIGH-SPEED, 2-NEEDLE OVERLOCK MACHINE  
**MO-3914**  
SUPER-HIGH-SPEED, SAFETY STITCH MACHINE  
**MO-3916**

## INSTRUCTION MANUAL

No.00  
29125309

Congratulations on your purchase of JUKI MO-3900 Series machines.

Please read this Instruction Manual carefully before using these units in order to get the most out of them and to enjoy using them for a long time.

[ For the first one month or so, operate the machine ]  
[ at about 80% speed of its max. sewing speed. ]

### BEFORE OPERATION

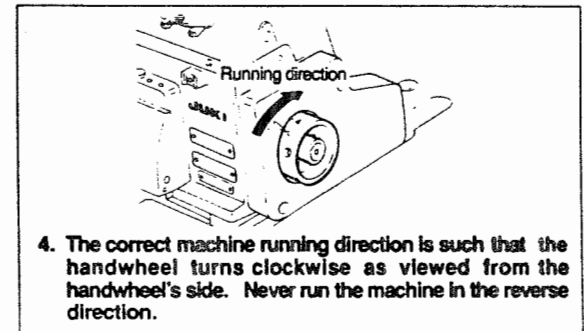
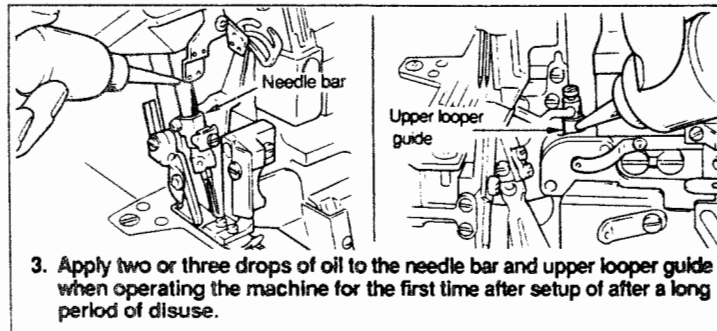
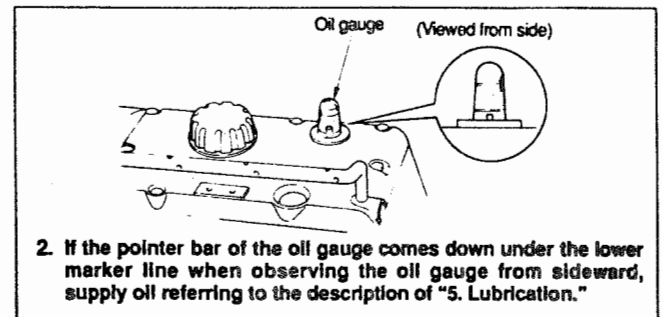
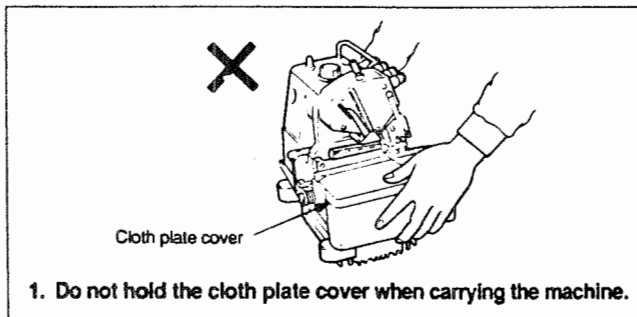

### CAUTIONS IN OPERATION

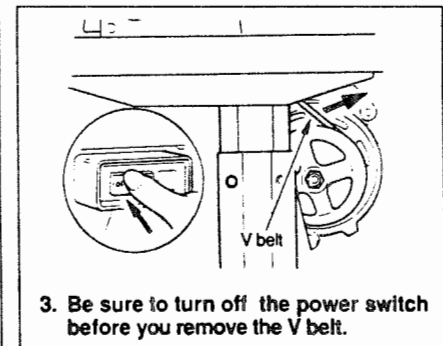
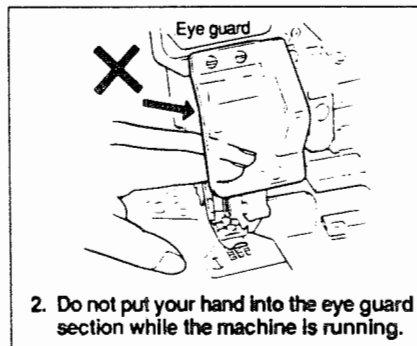
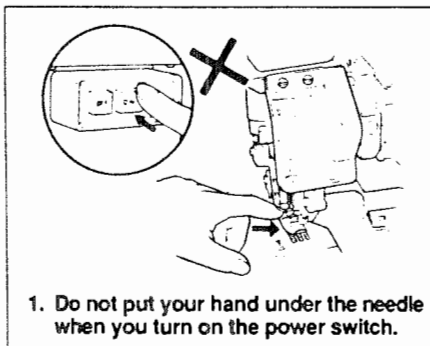

4. During operation, be careful not to allow your or any other person's head, hands or fingers to come close to the handwheel, V belt and motor. Also, do not place any instrument, tool or anything that is not necessary for sewing close to them. Doing so is dangerous.
5. If your machine is provided with a belt cover, finger guard, eye guard or any other protectors, do not operate your machine with any of them removed. Doing so is very dangerous.
6. Before inspecting, adjusting or cleaning the machine, threading the machine head or replacing the needle, be sure to turn OFF the power to the machine so as to prevent an accident and confirm that the sewing machine will not operate even when depressing the foot pedal of the sewing machine.
7. If your machine is equipped with a clutch type motor, the motor will be kept running by inertia after turning OFF the power switch. It is dangerous to depress the foot pedal of the sewing machine while the motor is still running, because the sewing machine will start rotating abruptly. Be sure to keep the foot pedal of the sewing machine held depressed after turning OFF the power switch until the sewing machine completely stops.
8. When you leave from your machine, make sure to turn OFF the power to it.
9. In case of a power failure, make sure to turn OFF the power to the machine.
10. Do not wipe the surface of the machine head with lacquer thinner.



# 1. INSTALLING THE FRAME SUPPORT PLATE

## \* Semi-sunken type

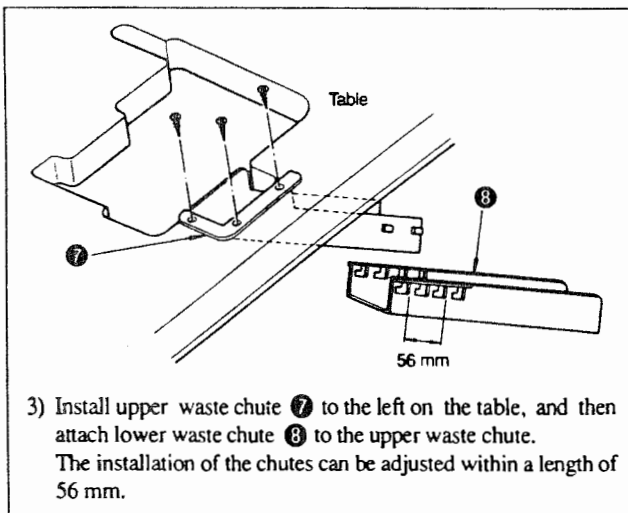
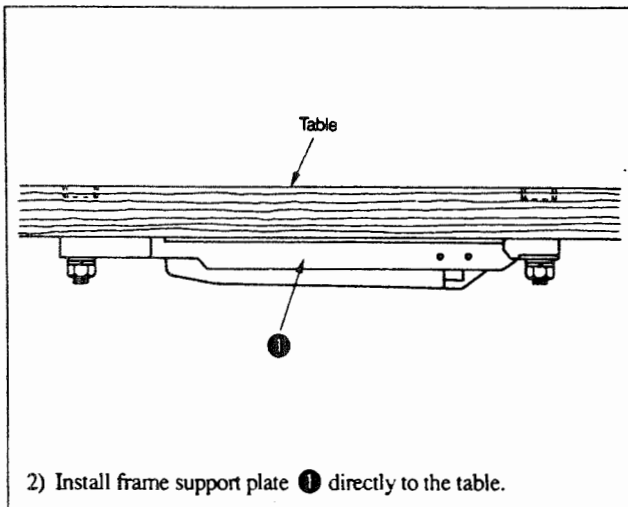
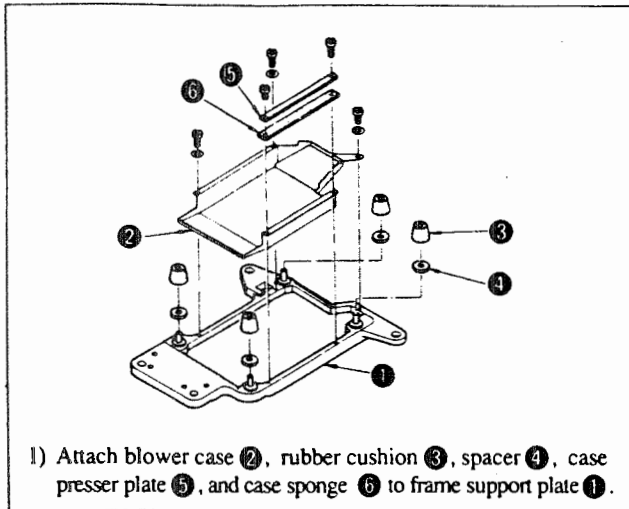

## \* Fully-sunken type

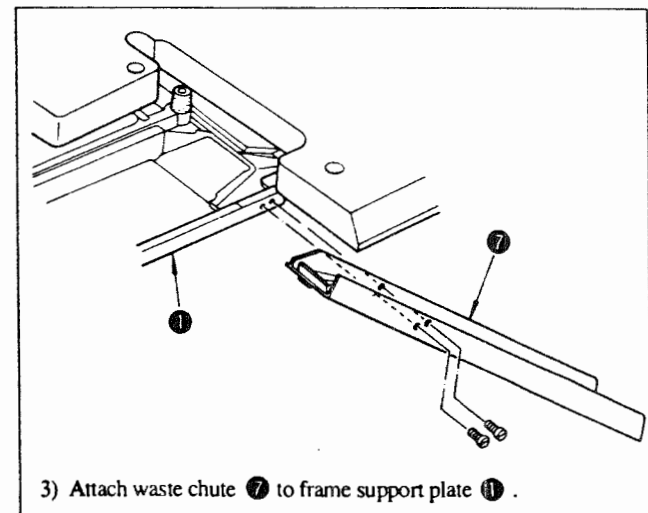
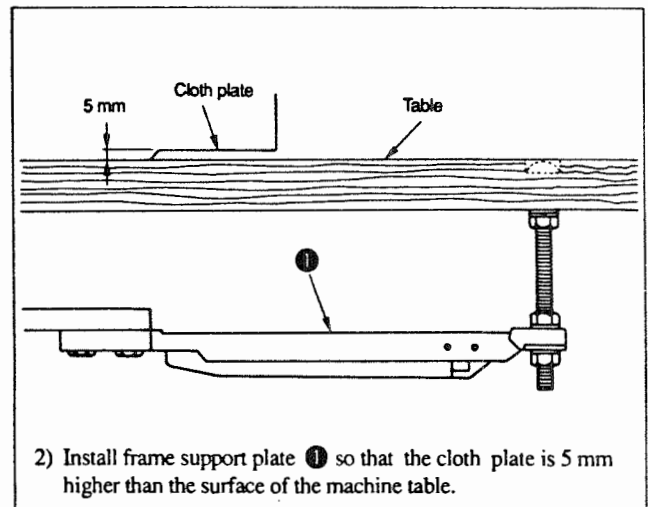
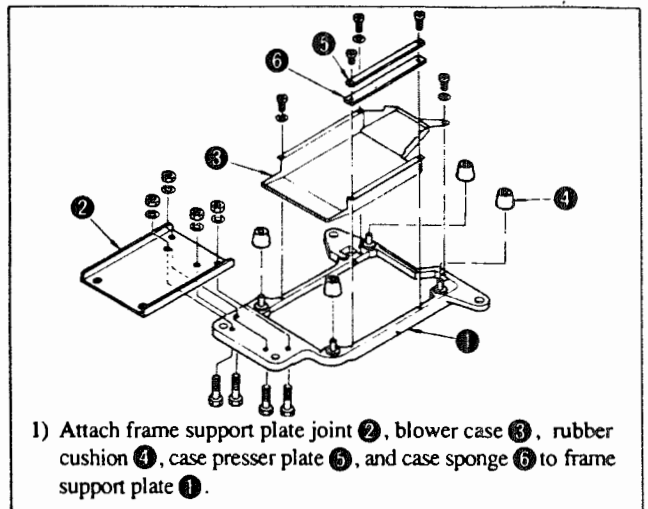



## 2. MOTOR PULLEY AND V BELT

| Sewing speed<br>(s.p.m.) | 50 Hz                           |                         |                          | 60 Hz                           |                         |                          |
|--------------------------|---------------------------------|-------------------------|--------------------------|---------------------------------|-------------------------|--------------------------|
|                          | Motor pulley<br>outer dia. (mm) | V belt (inch)           |                          | Motor pulley<br>outer dia. (mm) | V belt (inch)           |                          |
|                          |                                 | Semi-<br>sunken<br>type | Fully-<br>sunken<br>type |                                 | Semi-<br>sunken<br>type | Fully-<br>sunken<br>type |
| 8500                     | 160.5                           | 40                      | 36                       | 135.5                           | 38                      | 34                       |
| 8000                     | 150.5                           | 40                      | 34                       | 125.5                           | 38                      | 32                       |
| 7500                     | 140.5                           | 38                      | 34                       | 120.5                           | 38                      | 32                       |
| 7000                     | 130.5                           | 38                      | 34                       | 110.5                           | 36                      | 32                       |
| 6500                     | 120.5                           | 38                      | 32                       | 100.5                           | 36                      | 32                       |
| 6000                     | 110.5                           | 36                      | 32                       | 95.5                            | 35                      | 30                       |
| 5500                     | 100.5                           | 36                      | 32                       | 85.5                            | 35                      | 30                       |
| 5000                     | 90.5                            | 35                      | 30                       | 80.5                            | 34                      | 30                       |
| 4500                     | 85.5                            | 35                      | 30                       | 70.5                            | 34                      | 30                       |

- 1) If the sewing speed of the machine exceeds 7,500 s.p.m., the machine is equipped with a clutch motor of 3/4 HP (550W). If it is 7,500 s.p.m. or lower, the machine is equipped with a clutch motor of 1/2 HP (400 W).
- 2) Use an M type V belt.
- 3) The table on the left shows the sewing speeds obtained by the use of motor pulleys with different diameters and V belts with different lengths.
- 4) Note that the effective diameter of the pulley of the machine head is 50 mm.

## 3. ATTACHING THE BELT COVER

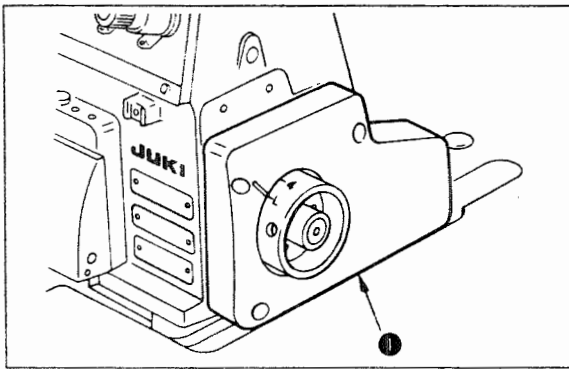

Install belt cover ① to the machine head.

## 4. INSTALLING THE PEDALS

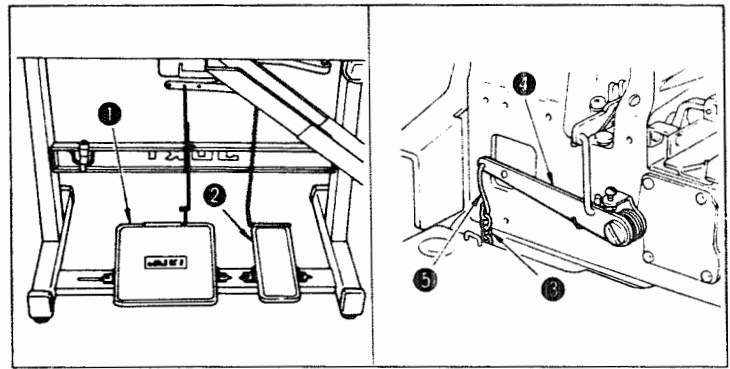

- 1) Install starting pedal ① on the left and presser lifter pedal ② on the right as seen from the operator.
- 2) Use an S-shaped hook ⑤ to connect the chain ③ of the presser lifter pedal to presser lifting lever ④.



## 5. LUBRICATION

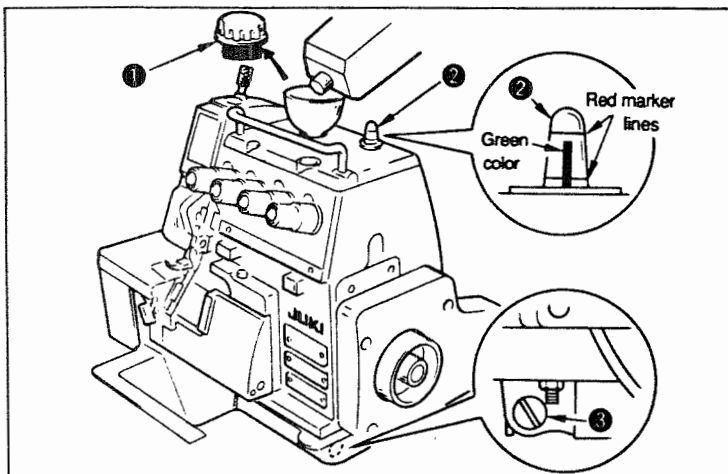

- 1) Remove oil cap ①.
  - 2) Pour JUKI New Defrix Oil No. 2 into the oil reservoir.
  - 3) Supply oil until the pointer bar almost reaches the upper red marker line when oil gauge ② is observed from the side.
- (Caution) Be careful not to exceed the upper red marker line, or else troubles due to excessive lubrication may result.
- 4) Remove oil drain cap ③ when draining the oil reservoir.

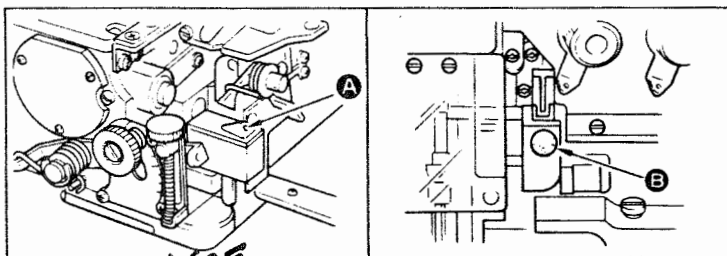

### \* Lubrication the needle cooler

- 1) Open cloth plate cover and supply silicon oil from section A.
- 2) Remove plug B, and supply silicon oil.
- 3) Infiltrate silicon oil also into the oil felt if the machine is started immediately after lubricating the needle cooler.

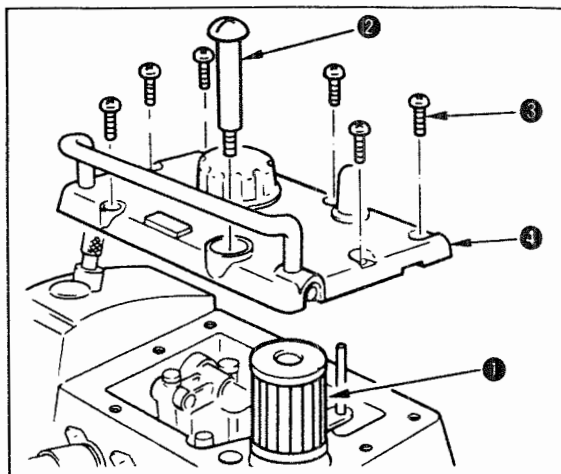

### \* Checking the cartridge filter and replacing it

1. After a long period of usage, cartridge filter ① may become clogged with dust. If the machine is left in this state, the dirty oil may fail to pass through cartridge filter ①, and the machine may wear out abnormally, or a seizure may result.
  - \* Cartridge filter ① should normally be checked once every six months, and cleaned or replaced accordingly.
2. How to inspect the cartridge filter and replace it
  - 1) Remove first oil discharging screw ②.
  - 2) Remove screws ③, and lift top cover ④ just above until it comes off.

(Caution) If top cover ④ is shifted sideward, the oil amount pointer bar and the cartridge filter may be damaged.
- 3) Remove cartridge filter ① and check it. If the filter is found to be abnormal, clean the relevant components, or replace cartridge filter ①.
- 4) Re-insert cartridge filter ① into its proper position and return the cover. Do not forget to put back the setscrews and tighten them up.

## 6. ATTACHING NEEDLES

MO-3904

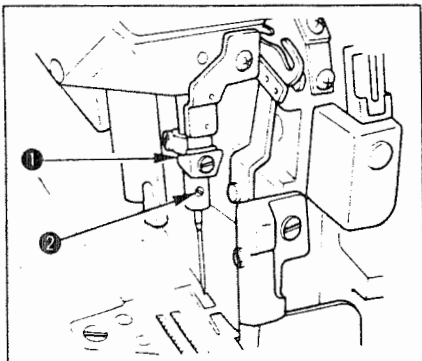

MO-3914

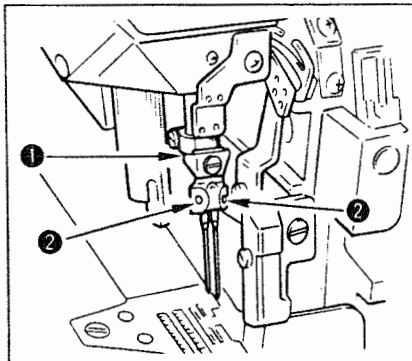

MO-3916

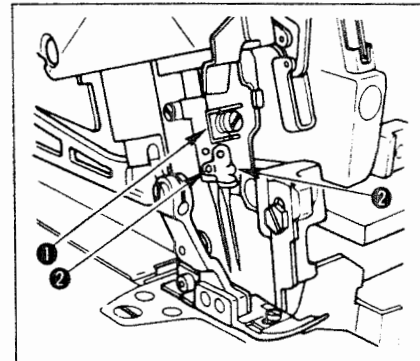

The standard needle is "DCx27 #11." You can also use the DCx1 needle. In this case, however, the clearance provided between the needle and the looper may be required to be adjusted. If sewing need to be carried out with a finely-adjusted thread tension, use the DCx27 needle.

Attach the needles according to the following procedure:

- 1) Bring needle clamp ① to the highest position.
- 2) Loosen needle clamp screw ②, and fully insert the needle into the needle clamp hole with the needle recess facing backwards as viewed from the operator's side.
- 3) Tighten the needle clamp screw.



## 7. THREADING THE MACHINE

Thread the machine according to the threading chart given below. (The same chart is on the inside of the looper cover.)

MO-3904

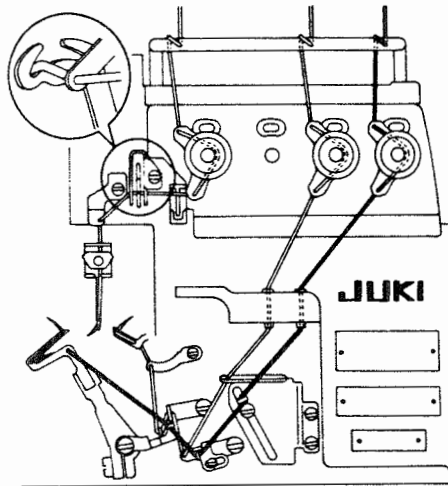

MO-3914

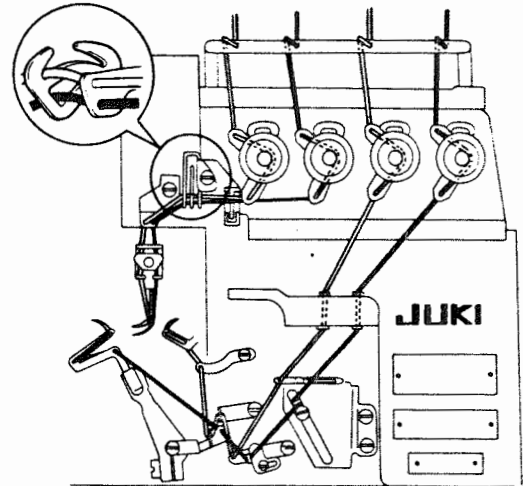

MO-3916

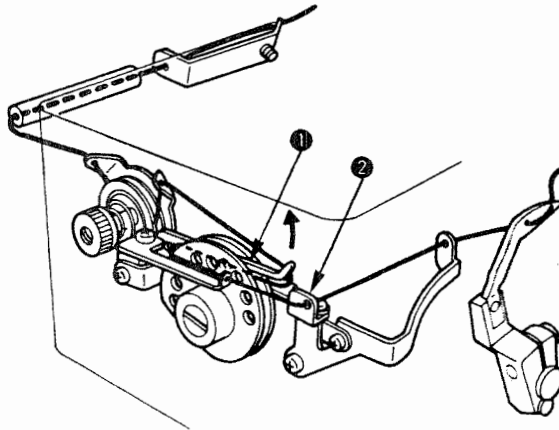

(Caution) Raise looper thread cam thread guide ① and perform threading. Return looper thread cam thread guide ① to its home position and securely fix it to retensing spring ②.

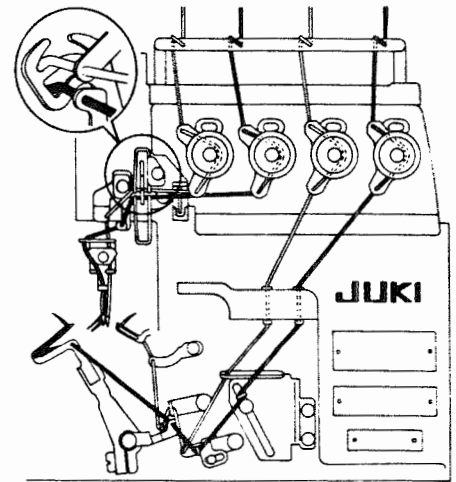

(Caution) Be sure to pass the needle thread for double chainstitch through the needle thread take-up lever. (Pass the needle thread for overlocking through the thread take-up lever located outside.)

### \* How to thread the needle thread silicon oil tank

| When the needle cooler is used         | When the needle cooler is not used     |
|--|--|
|  |  |
| Pass the thread under the center pawl. | Pass the thread above the center pawl. |

(Caution) When using an untwisted thread such as wooly nylon thread or weak thread, do not wind it round the intermediate thread guide.

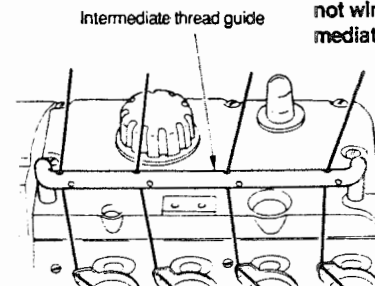



## 8. PRESSER FOOT PRESSURE AND LIFTER

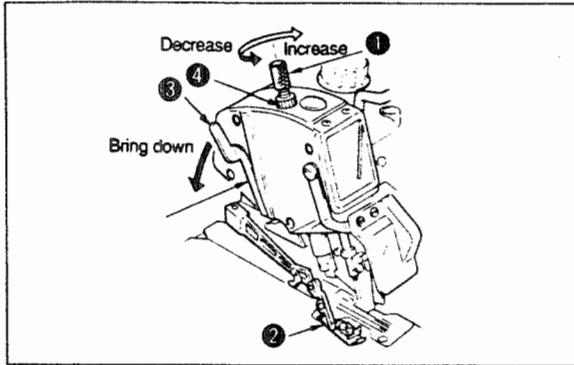

- 1) Adjust the pressure of the presser foot by loosening first nut ④ and turning presser foot adjust screw ①. When the adjust screw is turned clockwise, the pressure will increase. When it is turned counterclockwise, the pressure will decrease. After the adjustment, be sure to turn nut ④ without fail.
- 2) To open presser foot ② sideward, lower presser bar lifting lever ③.

## 9. ADJUSTING THE STITCH LENGTH

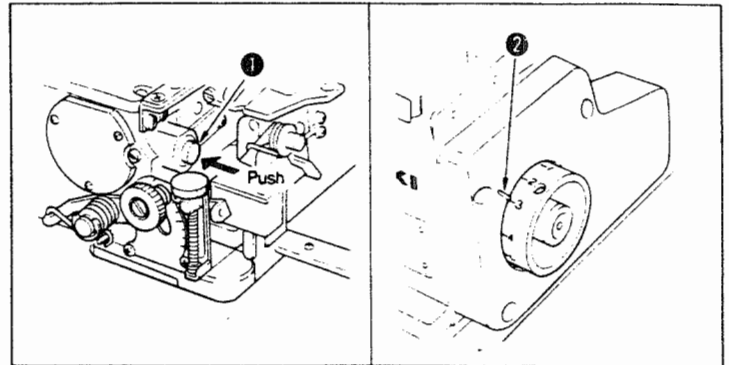

- 1) Slowly turn the handwheel as you keep depressing pushbutton ①, and you will find a point at which the pushbutton goes in farther.
- 2) With the above condition maintained, align the desired scale mark on the handwheel with mark ② on the belt cover.
- 3) Reset the pushbutton after setting the dial.

## 10. LOCKING MECHANISM OF FEED CAM

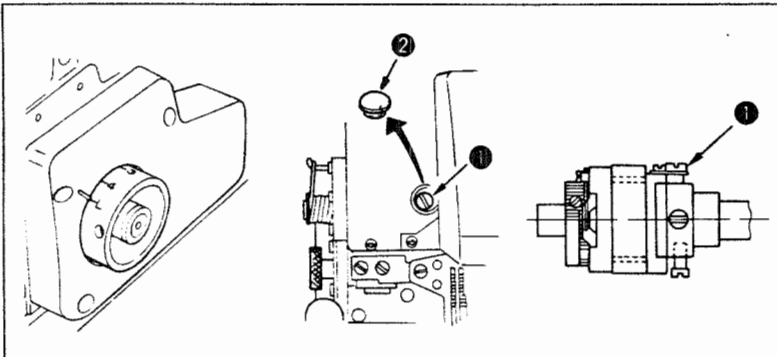

If the sewing machine is operated continuously for serging or other occasions (or the machine is used in a sewing process where frequent change of the stitch length is not required), it will be better to fix the feed cam. This will prolong the life of the machine.

Align "L" on the pulley with the marker line engraved on the belt cover. Then remove rubber cap ② from the feed cover.

Now, feed cam fixing screw ① is seen. Fix the feed cam by tightening the screw.

## 11. DIFFERENTIAL FEED MECHANISM

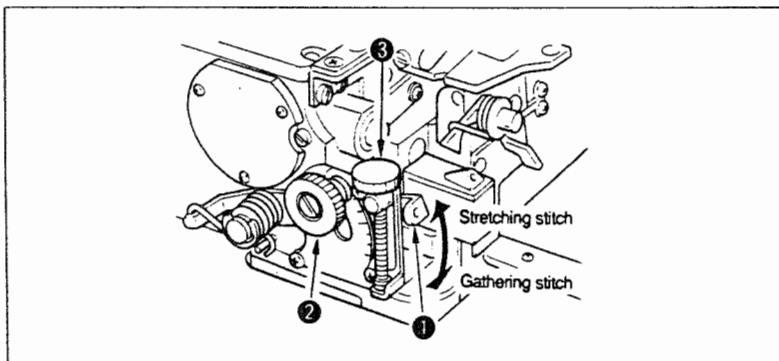

- 1) Loosen differential feed lock nut ②. Move lever ① up for stretching stitch or down for gathering stitch.
- 2) When you want to move the lever ① only slightly, use differential feed minute-adjust screw ③.
- 3) When the differential feed adjusting lever is set to graduation S, the machine will perform stretching with a differential feed ratio of 1:0.7. When the lever is set to graduation 0, the differential feed ratio between the main feed dog and the differential feed dog will be 1:1.
- 4) The maximum differential feed ratio for gathering is 1:2 (it can be set to 1:4 depending on the adjustment of the internal mechanism of the sewing machine). The graduations beyond 0 are used as reference.



## 12. KNIVES AND OVEREDGE WIDTH

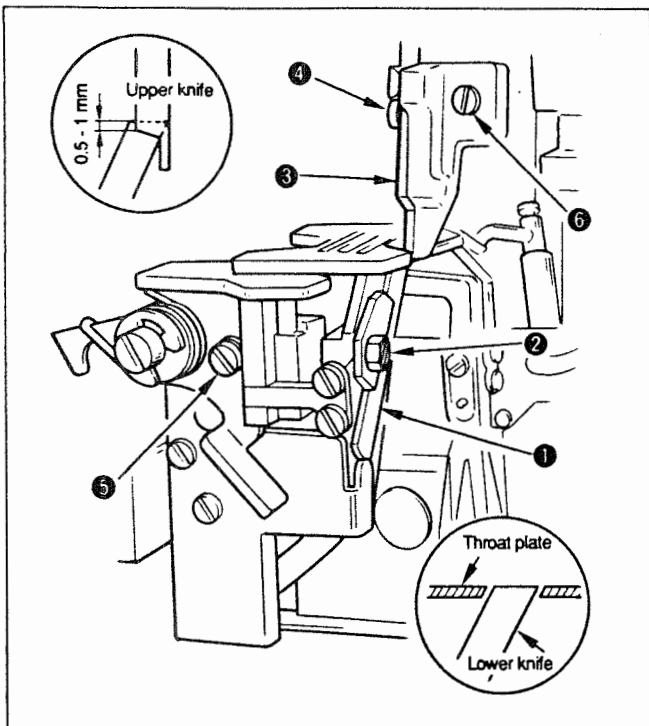

### \* Height of the lower knife

Loosen setscrew ② and adjust the height of lower knife ① so that its edge is flush with the throat plate surface.

### \* Height of the upper knife

Loosen setscrews ④, and perform adjustment so that upper knife ③ overlaps lower knife ① 0.5 to 1 mm when the upper knife is at its lowest point.

### \* Overedge width

Overedge widths of 1.6 through 6.4 mm are provided by changing the parts or by using subclass models. (The overedge width will be slightly larger than the knife cut width.) To change the overedge width:

- 1) Loosening setscrew ⑤, push lower knife ① to the left and fix it.
- 2) Loosen setscrew ⑥ and move upper knife ③ as required, then fix it.
- 3) Lower the upper knife to its lowest point and loosen setscrew ⑤. Tighten setscrew ⑤ when the lower knife comes in contact with the upper knife.

(Caution) 1. Be sure to tighten screw ⑤ before operating machine.  
2. After the completion of adjustment, make the knives cut a thread to check for sharpness of the knives.

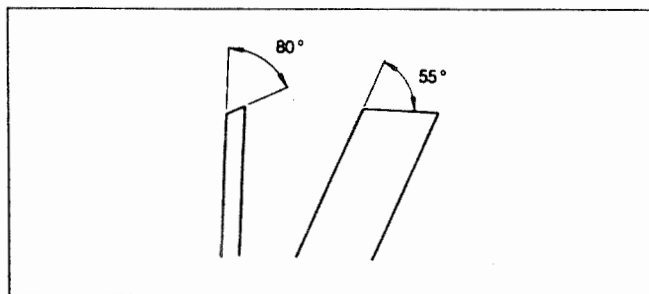

### \* Resharpener the lower knife

When the lower knife has become dull, resharpen it as shown in the figure left.

## 13. SPECIFICATIONS

|                         | MO-3904   | MO-3914  | MO-3916                         |
|-------------------------|---|--|---------------------------------|
| Sewing speed (Max.)     | 9,000 s.p.m.  | 8,000 s.p.m.<br>(excluding some subclass models) | 8,000 s.p.m.                    |
| Stitch length           | 0.8 - 4 mm (can be set to 5 mm in accordance with special specifications) |  | 1.5 - 4 mm (5 mm)               |
| Needle gauge            | —   | 1.6, 2.0, 2.4 mm                                 | 1.6, 2.0, 2.4, 3.2, 4.8, 6.8 mm |
| Overedge width          | 1.6, 2.4, 3.2, 4.0, 4.8, 6.4 mm   | 2.0, 3.2, 4.0, 4.8 mm                            | 3.2, 4.0, 4.8, 5.6, 6.4 mm      |
| Differential feed ratio | Gathering stitch 1:2 (Max. 1:4), Stretching stitch 1:0.7 (Max. 1:0.6)     |  |                                 |
| Needle                  | DCx27 (Standard) DCx1 may be used   |  |                                 |
| Presser foot lift       | 7.0 mm  | 7.0 mm<br>(excluding some subclass models)       | 7.0 mm                          |
| Lubricating oil         | JUKI New Defrix Oil No. 2   |  |                                 |

