

MODEL LU-1114-4 LU-1114-5

1-NEEDLE UNISON FEED LOCKSTITCHER
WITH AUTOMATIC THREAD TRIMMER

INSTRUCTION BOOK

Before operating your JUKI Lockstitch Machine, please read this Instruction Book carefully in order to operate it in the correct and efficient manners.

CAUTIONS BEFORE OPERATION

1. Don't run the machine before filling the oil reservoir with the prescribed lubricating oil.
2. After setting up your machine, make sure that it runs in the correct direction; lower the needle by turning the handwheel and watch the handwheel's revolution by momentarily switching the power "on" (correct rotational direction of the handwheel: counterclockwise when viewed from the handwheel's end).
3. Run the newly installed machine at a speed of 2,000 s.p.m. or lower for the first 4 weeks.
4. Don't hold the machine by its synchronizer behind the handwheel when you move the machine head for installation.
5. Confirm the ratings of your power source by the machine plate stuck on the motor (power voltage, phase etc.).

CAUTIONS IN OPERATION

1. Don't put your hand under the needle when you turn "on" the power switch and the machine is running.
2. Don't put your hand into the thread take-up cover while the machine is running.
3. Don't forget to cut off the power supply before you tilt the machine head backwards or replace the V-belt.
4. Never bring your fingers or hair close to, or place anything on the handwheel, V-belt, bobbin winder wheel or motor during operation. It may lead to serious personal injuries.
5. If your machine is provided with a belt cover, finger guard and eye guard, never operate your machine with any of them removed.

SPECIFICATIONS

Fabric	Medium weight, Heavy-weight and Extra heavy-weight
Sewing speed	See "37. TABLE OF SEWING SPEED FOR EACH STITCH LENGTH" (P.10)
Stitch length (max.)	Forward: 10 mm, Reverse: 4 mm
Needle	DI x 3 or DP x 17 #18 ~ #24 (Standard #23)
Presser foot lift	Hand lifter: 10 mm, Knee lifter: 13 mm
Lubricating oil	JUKI NEW DEFRIX OIL No. 1

1. INSTALLATION

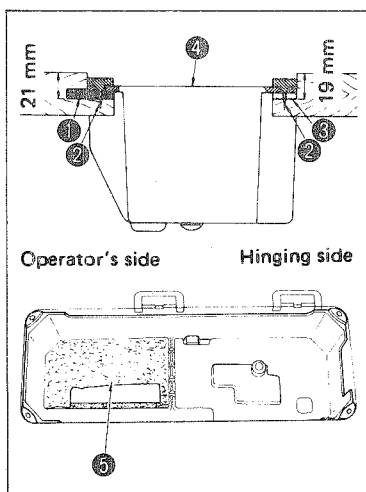

★ Attaching the oil reservoir:

Nail rubber cushions ① on two corners on the operator's side using nails ②, nail felt cushions ③ on the two corners on the hinging side using nails ② and place oil reservoir ④ in the way that it is supported by these four corners.

Place foamed polyurethane pad ⑤ on the bottom of the oil reservoir.

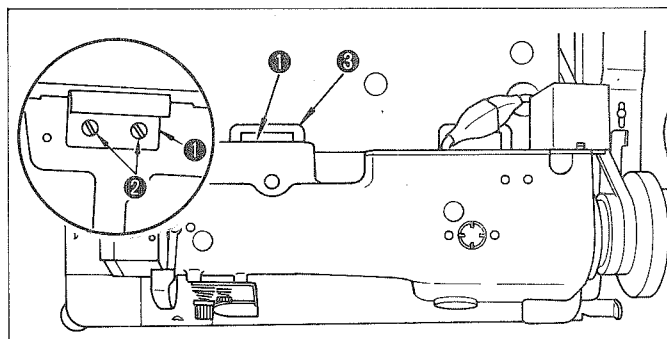

Fasten hinge ① to the bed surface using flush-head screws ② and place the head on the rubber cushions ③ on the table.

2. LUBRICATION

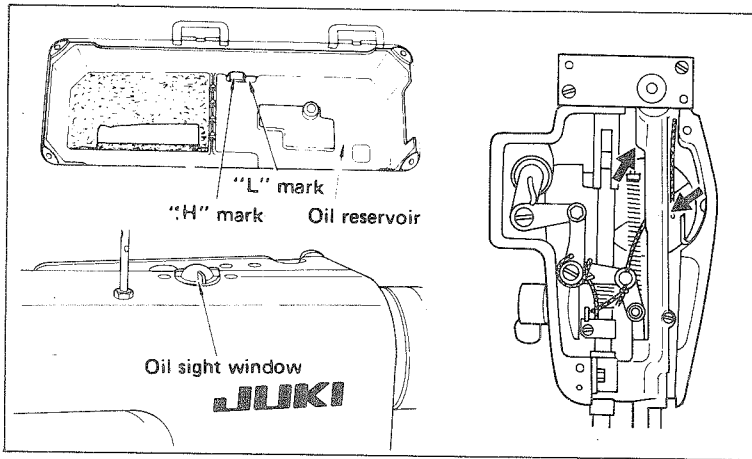

☆ Before operating machine:

1. Pour the JUKI New Defrix Oil No. 1 into the oil reservoir up to "H" mark.
2. Add the same lubricating oil as soon as the oil level has come down to the "L" mark level.
3. Run the machine and make sure that the oil splash is seen in the oil tank window.

(CAUTION) Before operating newly installed machines or machines which have not been used for a relatively long period of time, apply two or three drops of oil to the parts by arrows and let them idle for about 10 minutes at 1800 s.p.m.

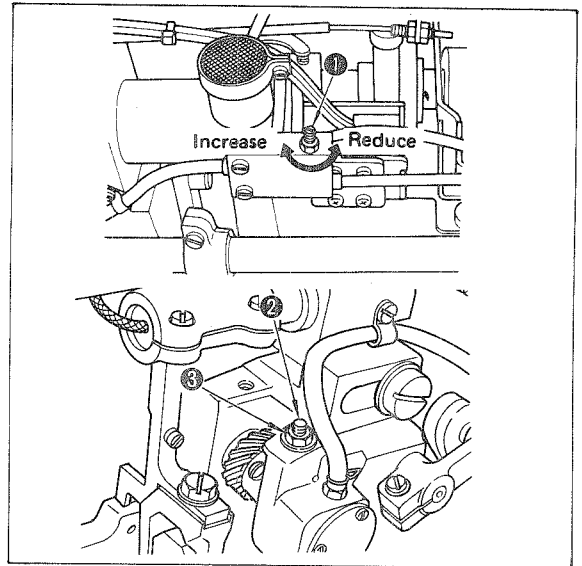

☆ Adjustment of oil amount for the face plate components:

Turn screw ① clockwise to increase or counter-clockwise to reduce the amount of lubricating oil supplied to the components in the face plate.

☆ Adjustment of oil amount for the hook:

Loosen nut ③ and turn adjusting screw ② clockwise to increase or counter clockwise to reduce the amount of oil fed to the hook.

(CAUTION) In order to prevent adjusting screw ② from breakdown, gently tighten nut ③.

3. INSTALLATION OF THREAD STAND

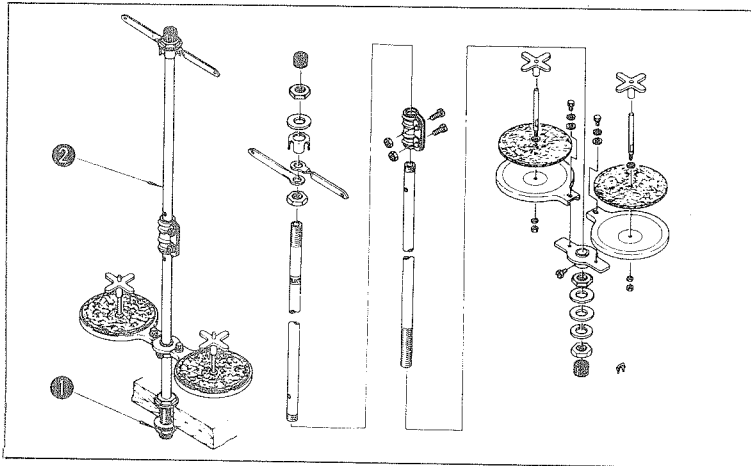

Assemble the thread stand, set it up on the machine table using the installation hole in the table and tighten nut ① gently. When you use power supplied by the overhead power line, pass the power supply cord through hollow spool rest rod ②.

4. ATTACHING THE BELT COVER AND THREAD WINDER

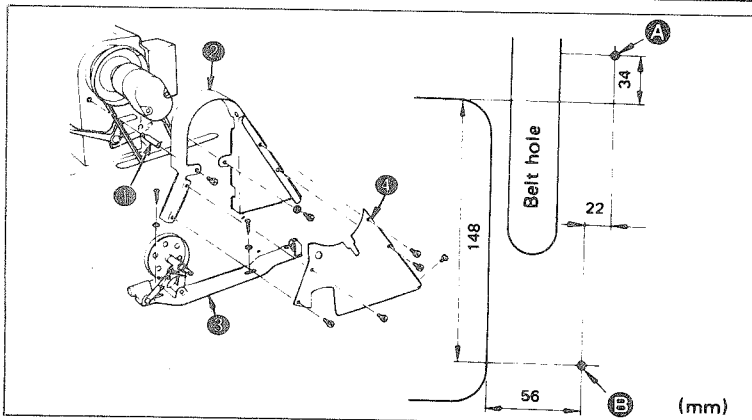

1. Make guide holes ① and ② in the table for wood screws.
2. Screw belt cover post ③ into the tapped hole in the machine arm.
3. Fix belt cover ④ to the belt cover post and then to the groove on the machine arm.
4. Put thread winder assembly ⑤ in the belt cover and adjust its position.
5. Attach top cover ⑥ to the belt cover.
6. Tilt the head back and make sure that the belt cover does not touch the table.
7. Fix the thread winder using the wood screws and guide holes ① and ②.

5. ATTACHING THE SYNCHRONIZER

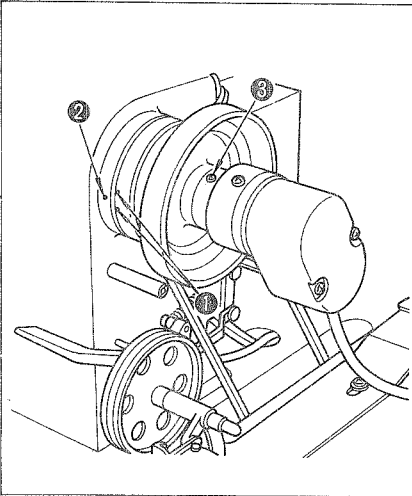

1. Attach the synchronizer to the handwheel.
2. Let the machine perform thread trimming action and adjust the position of the synchronizer by loosening its setscrews ③ so that the handwheel stops with its two white marking spots ① surrounding in the middle a red marking spot ② engraved on the machine arm.

(Note) Accurately position it through your trial sewing.

6. TILTING THE MACHINE HEAD

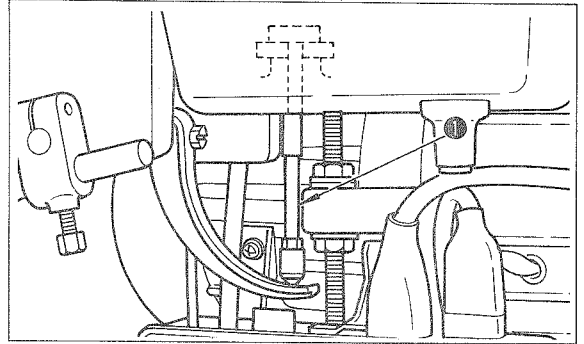

Be sure that knee lifter press bar ① is down before returning the machine head.

7. ATTACHING THE NEEDLE

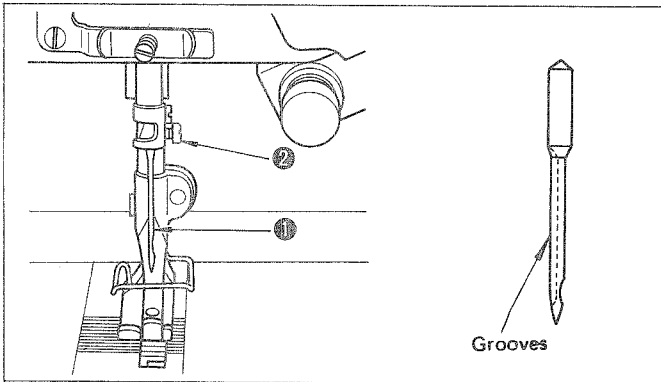

★ Turn off the motor switch.
Use DP x 17 or DI x 3 needle.

1. Turn the handwheel to bring the needle bar to the highest position of its stroke.
2. Loosen needle clamp screw ② and hold needle ① so that the long groove is facing exactly to the left.
3. Push the needle deep into the clamp hole until it will go no further.
4. Tighten the needle clamp screw ② firmly.

10. THREADING THE HOOK

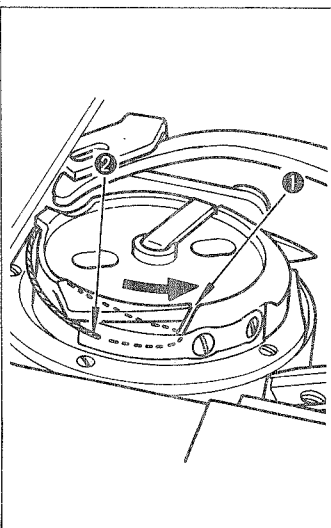

Pass the thread through thread path ① in the hook and draw the thread and the thread will be brought to thread hole ② via the tension spring.

- * Make sure that the bobbin revolves in the direction of the arrow when you draw the thread.

8. HOW TO TAKE OUT THE BOBBIN CASE

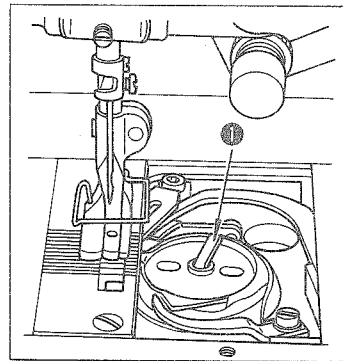

1. Lift latch ① and take out the bobbin together.
2. Put the bobbin into the shaft in the hook correctly and release the latch.

9. WINDING THE BOBBIN

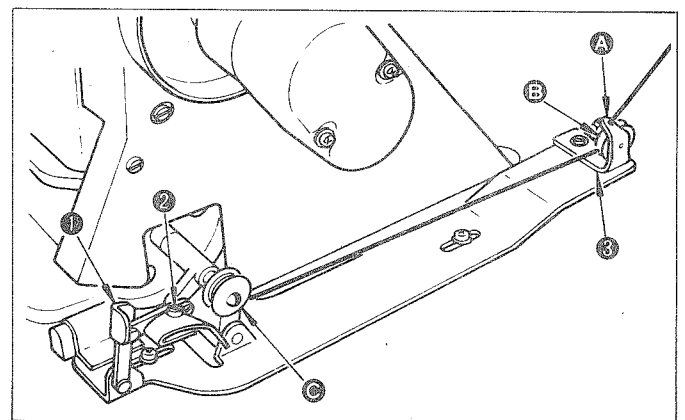

1. Take the thread end from a thread spool, pass it through the thread guides as illustrated (A, B, C) and wind it several turns round the bobbin.
2. Tilt bobbin presser ① permitting the thread winder pulley to touch the running belt.
3. Adjust screw ② to wind a bobbin about 80% of its capacity; turn the adjusting screw clockwise to increase or counterclockwise to reduce the amount of thread to be wound.
4. If the bobbin is wound unevenly, adjust it by moving the position of tension bracket ③ to the left or the right.
5. When the bobbin is filled up, the bobbin presser automatically releases the thread winder pulley from the running belt.

11. ATTACHING THE THREAD GUIDE PIN

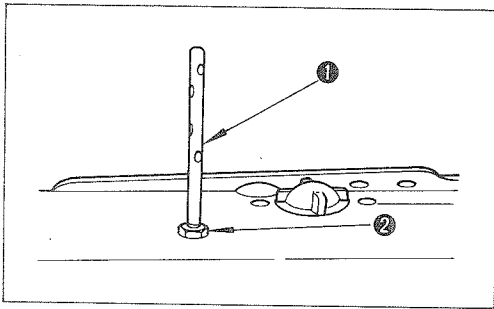

Using locknut ②, firmly fix needle thread guide pin ① supplied with the machine on the machine head.

13. STITCH LENGTH

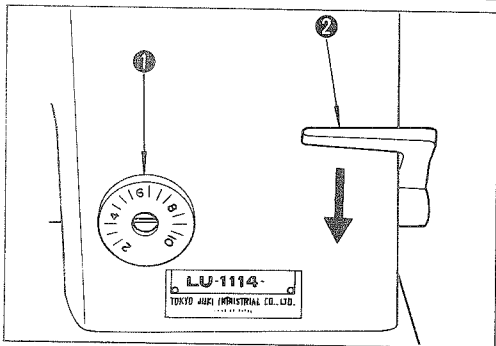

Set stitch dial ① for a desired stitch length.

★ Reverse feed operation.

1. Depress reverse feed control lever ②.
2. Reverse stitches are made as long as you keep depressing lever ②.
3. Release lever ②, and the machine will run forward.

15. CONNECTION OF THE PEDAL

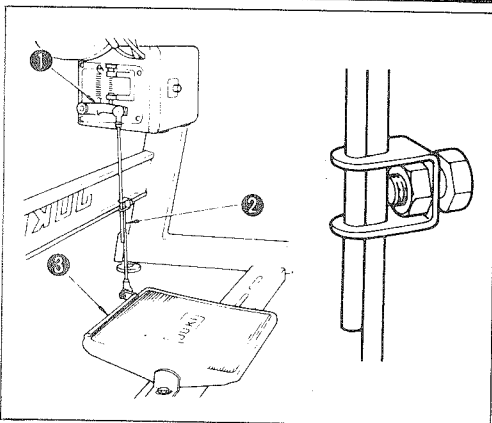

★ Attach the pedal connecting rod:

Move pedal adjusting plate ③ to the left or the right to make motor control lever ① and pedal connecting rod ② straight.

★ Adjusting the slant of the pedal:

Slant of the pedal is adjustable by changing the effective length of the pedal connecting rod. Tighten firmly the clamp screw of the connecting rod after the adjustment.

12. THREADING THE MACHINE

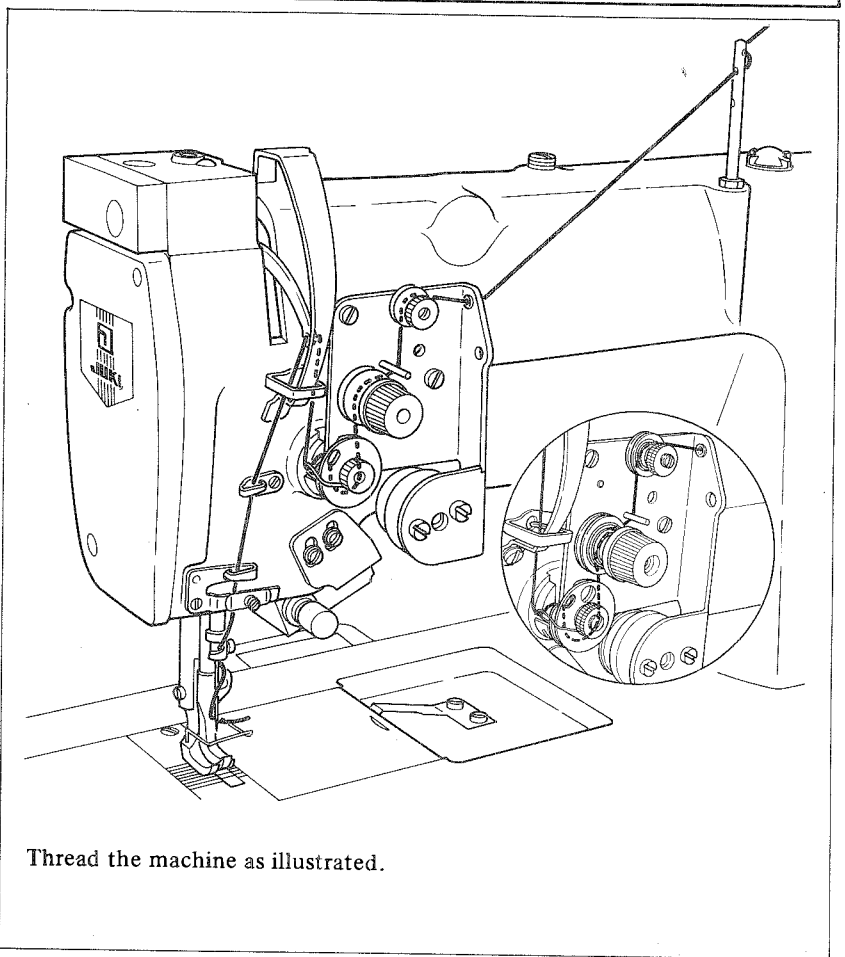

Thread the machine as illustrated.

14. HOW TO OPERATE THE PEDAL

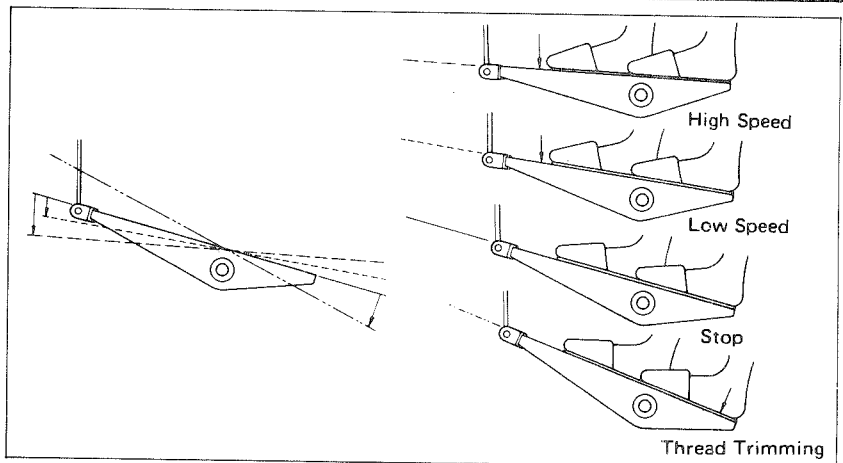

The pedal is operated in 4 stages.

1. Depress the pedal lightly forward for low-speed operation.
2. Depress the pedal further forward for high-speed operation.
3. Bring the pedal back to its initial position, and the machine will stop with the needle "up" or "down".
4. Depress the pedal backward (toe-up) for thread trimming.
 - You can depress the pedal backward for thread trimming directly from its high-speed or low-speed position.
 - You can bring the pedal back to its initial position immediately after you have confirmed the start of a thread trimming action. The machine will stop after completing a thread trimming action.
 - If you want to rise the needle which has stopped, in "down" position, depress the pedal once backward.

16. THREAD TENSION

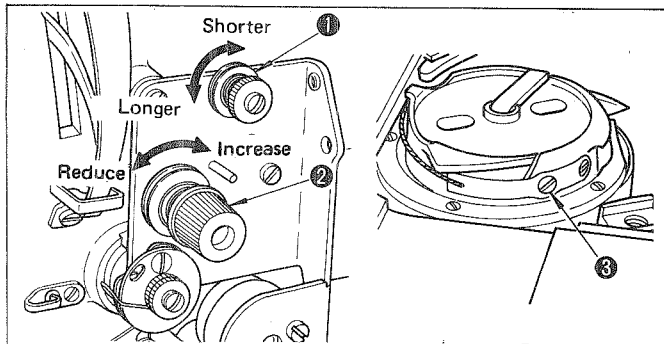

★ Needle thread tension

Turn thread tension nut No. 2 ② clockwise to increase or counterclockwise to reduce the needle thread tension.

Turn thread tension nut No. 1 ① clockwise to shorter or counterclockwise to longer the length of the thread left in the needle after thread trimming.

★ Bobbin thread tension

Turn tension adjusting screw ③ clockwise to increase or counterclockwise to reduce the bobbin thread tension.

17. THREAD TAKE-UP SPRING

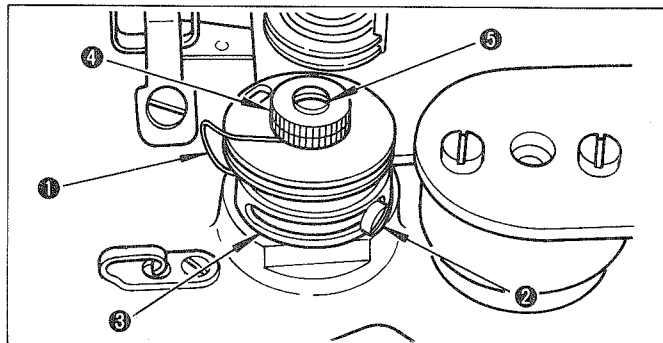

★ When you want to change the stroke of the spring:

1. Stroke of take-up spring ① is adjustable by moving stopper ③ to the left or the right after loosening stopper setscrew ②.
2. Move the stopper to the right to increase or to the left to reduce the stroke of the take-up spring.

★ When you want to change the tension of the spring:

1. Tension of the take-up spring is adjustable by turning stud ⑤ counterclockwise to increase or clockwise to reduce after loosening nut ④.

18. HAND LIFTER

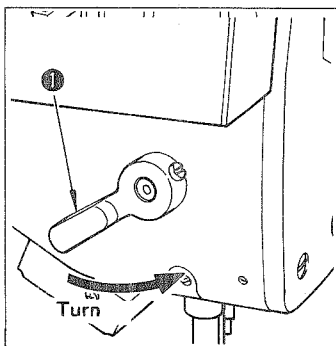

When you want to keep the presser foot in the lifted position, turn hand lifter ① in the direction of the arrow. By so doing, the presser foot will rise 10 mm (25/64") and stay until the hand lifter is lowered. Operate the knee lifter, and the presser foot will rise 13 mm (33/64") from its working level.

19. ADJUSTMENT OF THE PRESSURE OF THE PRESSER FOOT

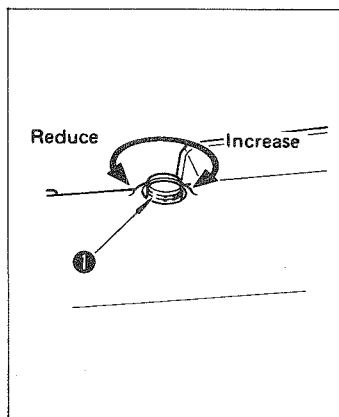

Turn presser spring regulator ① clockwise to increase or counterclockwise to reduce the pressure of the presser foot.

20. RELATION BETWEEN THE MAIN SHAFT AND THE HOOK DRIVING SHAFT

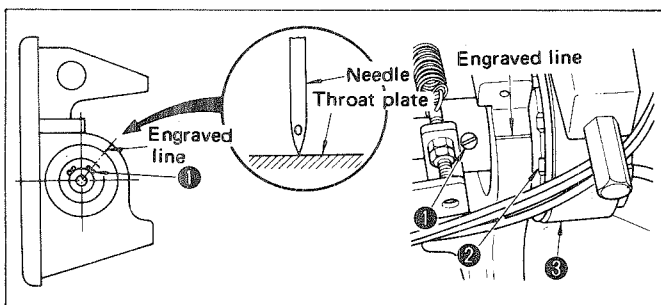

Relation between the main shaft and the hook driving shaft is determined by the timing belt. If you replace or remove the timing belt from the shaft for repair or adjustment of the related parts, you must position the timing belt exactly in the following way;

1. Set the stitch dial to "0".
2. Turn the handwheel in the normal direction until the pointed end of the needle had come down to the level of the throat plate.
3. Turn the hook driving shaft in the normal direction until the center of No. 1 setscrew ① of the hook driving shaft thrust collar aligns with the engraved line on the bed.
4. Put timing belt ③ on lower sprocket wheel ② taking care not to move the hook driving shaft and the main shaft from the above-mentioned position.

21. ADJUSTING THE FEED TIMING

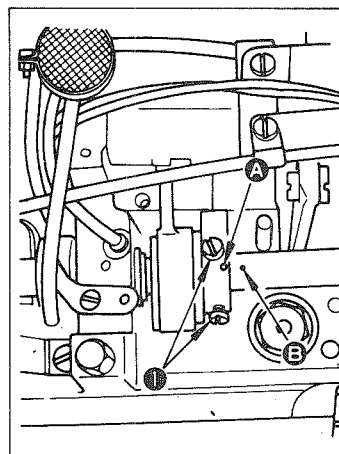

The feed eccentric guide must be fixed in phase with the hook driving shaft.

1. Loosen screws ① which set the feed eccentric guide.
2. Align engraved marker spot ④ on the eccentric guide with marker spot ⑤ on the hook driving shaft.

(CAUTION) When adjusting the feed eccentric guide, take care not to move it in the axial direction. Because it may increase the load.

22. HEIGHT OF THE FEED DOG

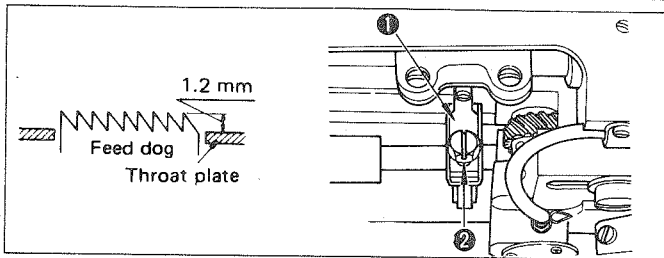

The feed dog must protrude its teeth 1.2 mm from throat plate surface when it has come up to the highest point of its trajectory.

1. Turn the stitch dial fully clockwise.
2. Turn the handwheel in the normal direction to bring the feed dog to the highest point.
3. Loosen screw ② and adjust the height of the feed dog to 1.3 mm by moving feed bar slide fork ①.

23. HOW TO RESHARPEN THE FIXED KNIFE

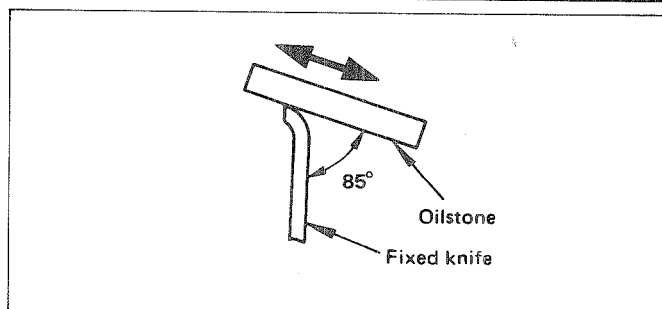

As soon as the thread trimmer knife becomes dull, sharpen the fixed knife as illustrated using an oilstone.

24. NEEDLE-TO-HOOK RELATION

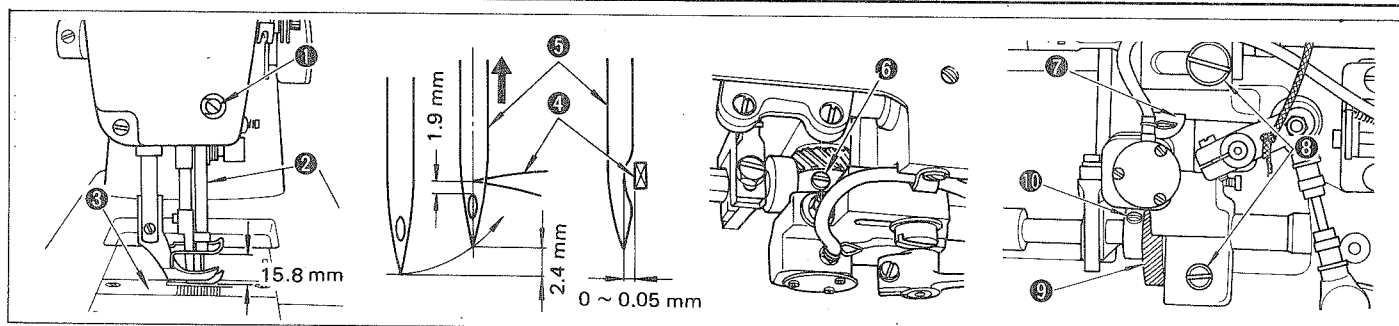

★ Set the needle to hook relation in the following way:

1. Set the stitch dial to 6.
2. Turn the handwheel to move the needle bar to the highest position and loosen screw ① of the needle bar.
(Set the needle bar height)
3. Adjust the height of the needle bar so the bottom end of needle bar ② is 15.8 mm above the surface of throat plate ③ when the needle bar is at its lowest point. After adjustment, tighten screw ① of the needle bar clamp.
(Set the hook)
4. Turn the handwheel until the needle bar goes up 2.4 mm above its lowest point and adjust so hook blade point ④ meets the center of needle ⑤.
Tighten three setscrews ⑥ of the screw gear (small). When tightening one of the three setscrews ⑥, which has a V-shaped end, fit it to the V-shaped groove in the hook driving shaft.
5. Loosen two setscrew ⑧ to release hook driving shaft saddle ⑦ and move the hook driving shaft saddle to the right or left to adjust so a clearance of 0 to 0.05 mm is provided between the hook blade point and the needle when the hook blade point meets the center of the needle. After adjustment, firmly tighten setscrews ⑧.
6. Loosen two setscrews ⑩ to release screw gear (large) ⑨ and move the screw gear (large) to the right or left to adjust so the hook blade point meets the center of the needle. After adjustment, tighten setscrews ⑩. When tightening the first screw of the two setscrew ⑩, set it to the flat of the hook driving shaft.

25. HOOK NEEDLE GUARD

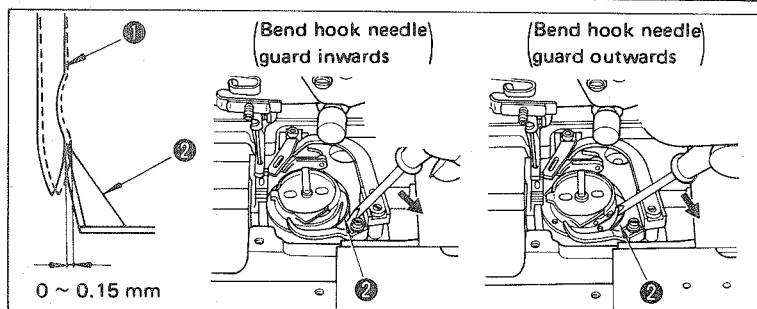

When a hook is replaced, you must adjust the working point of the hook needle guard. Hook needle guard ② must push needle ① away for 0 or 0.15 mm. Adjust it by carefully bending the hook needle guard.

1. If you want to bend it inwards, do it from the outside of the hook needle guard using a screw driver.
2. If you want to bend it outwards, do it from the inside of the hook needle guard using a screw driver.

26. BOBBIN CASE OPENING LEVER

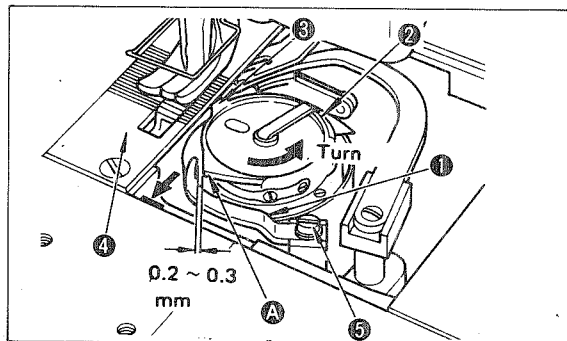

1. Turn the handwheel in the normal direction until bobbin case opening lever ① has entirely withdrawn from its working position.
2. Turn bobbin case ② in the direction of the arrow until stopper ③ rests in the groove on throat plate ④.
3. Loosen screw ⑤ and provide a 0.2 to 0.3 mm clearance between the bobbin case opening lever and protrusion ⑥ on the bobbin case.

27. INITIAL POSITION OF THE MOVING KNIFE

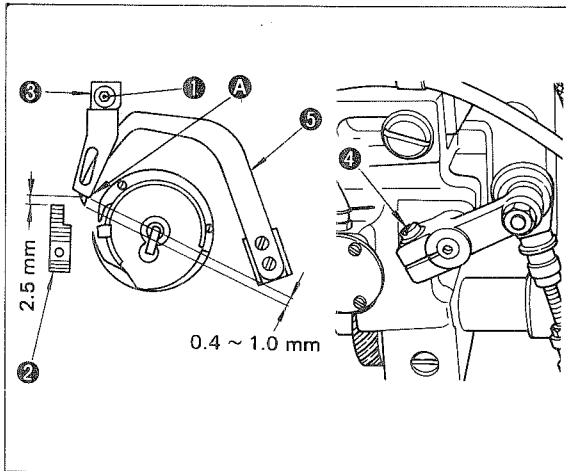

1. Turn the stitch dial fully clockwise.
2. Turn the handwheel to lower the needle and adjust the position of the feed dog so the needle enters the center of the needle hole in the feed dog. When the feed dog has been properly positioned, fix the feed dog.
3. Turn the handwheel to lower the needle bar to the lowest point.
4. Loosen setscrew ① to release the fixed knife and adjust to provide a 2.5 mm clearance between the end of feed dog ② and ④ of fixed knife ③. When the 2.5 mm clearance has been obtained, tighten the setscrew.
5. Loosen screw ④.
6. Adjust to make the end of moving knife ⑤ jut out 0.4 to 1.0 mm from ④ of fixed knife ③ and tighten screw ④.
7. Turn the handwheel by hand two or three times and actuate the thread trimmer to check the moving knife for correct position.

(CAUTION) Be sure to provide the correct distance between the end of the moving knife and the fixed knife, otherwise the threads may not be clamped or trimmed properly.

30. ADJUSTMENT OF THE PRESSURE OF THE CLAMP SPRING

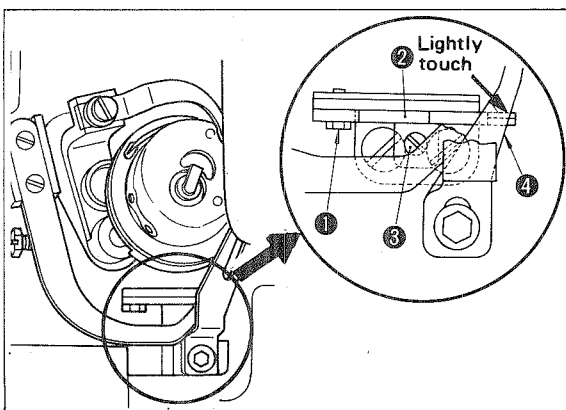

1. Loosen screw ①.
2. Screw in adjusting screw ③ until adjusting metal fittings ② lightly touches the clamp spring ④.
3. After adjustment, securely tighten screw ① to fix adjusting metal fittings ②.

(CAUTION) Be careful not to overtighten adjusting screw ③, or else an excessive spring pressure will result and inferior clamping may often occur.

28. THREAD TRIMMER CAM

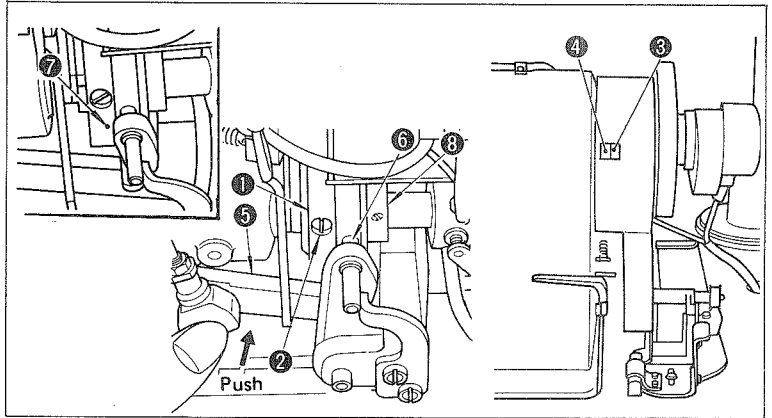

1. Loosen two screws ② which set the thread trimmer cam ①.
2. Align red marker spot ③ on the handwheel with red marker spot ④ on the machine arm.
3. Push cam follower ⑤ to let cam roller ⑥ rest in the groove on the thread trimmer cam.
4. Turn the thread trimmer cam until its marker spot ⑦ aligns with the axis of the cam roller and fix the thread trimmer cam as you are pressing the thread trimmer cam of thrust collar ⑧.

29. HEIGHT OF THE MOVING KNIFE

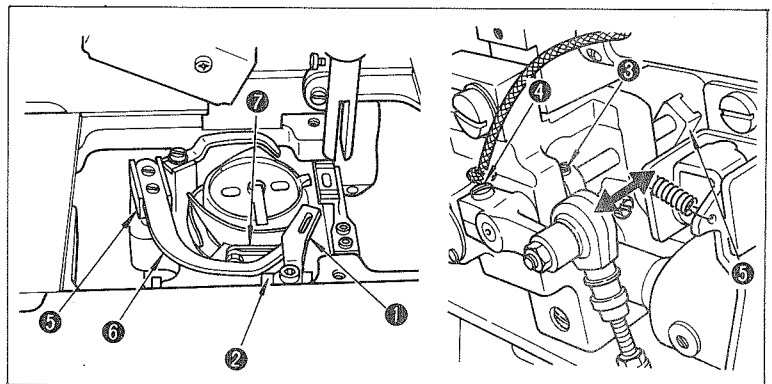

1. Remove fixed knife ① from hook shaft saddle ②.
2. Loosen screws ③ to set free the moving knife shaft thrust collar.
3. Loosen screw ④ which clamps the rocker arm.
4. Adjust moving knife link ⑤ in the vertical direction to permit moving knife ⑥ to touch moving knife rest ⑦. Tighten screw ④.

31. THE LONGITUDINAL POSITION OF THE NEEDLE BAR FRAME

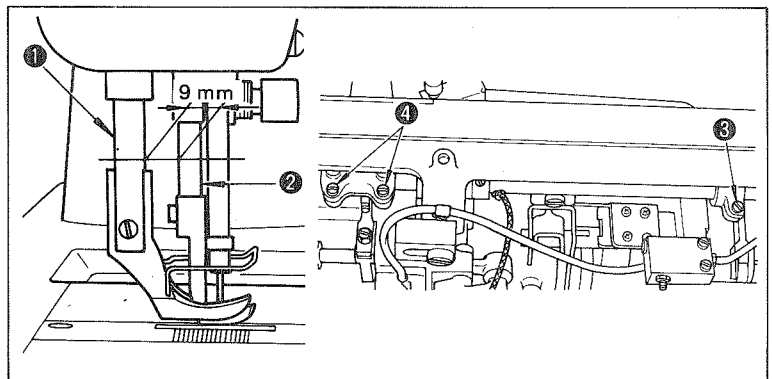

Turn the stitch dial fully counterclockwise to set the stitch length to approx. 0 mm. With the 0 mm stitch length setting, the distance between presser bar ① and walking bar ② should be 9 mm when the needle bar is at its lowest point.

To obtain the 9 mm distance, loosen screw ③ and adjust the distance between presser bar ① and walking bar ② to 9 mm and retighten the screw. Then, loosen screw ④ and adjust so the needle enters the center of the needle hole in the feed dog.

32. THE LIFTS OF THE PRESSER FOOT AND THE WALKING FOOT

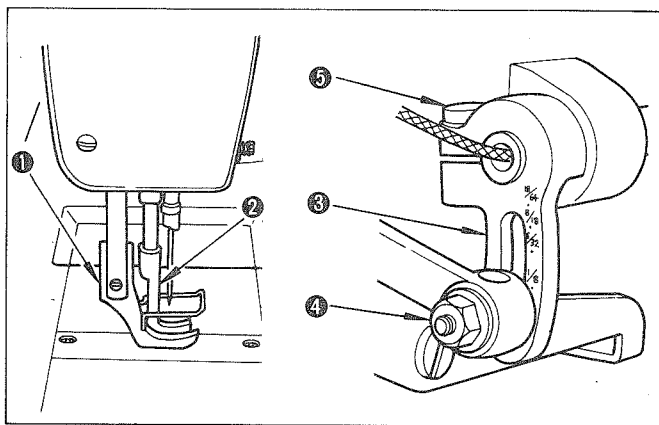

The lifts of the presser foot ① and the walking foot ② which alternately go up are normally set equal. If it is necessary to change the lifts, raise the upper feed driving rod to increase the lifts or lower it to decrease them within the slot in upper feed spring rod ③ and tighten nut ④. If presser foot ① is required to have a different lift from that of walking foot ②, adjust as follows: Make the sole of the presser foot flush with that of the walking foot on the throat plate surface, loosen screw ⑤ of the upper feed spring rod, turn the handwheel toward you, and tighten screw ⑤. By so doing, the presser foot will have a larger lift than the walking foot. If you turn the handwheel away from you and tighten screw ⑤, the walking foot will have a larger lift than the presser foot.

33. POSITIONING THE HAND LIFTER MOUNTING BRACKET

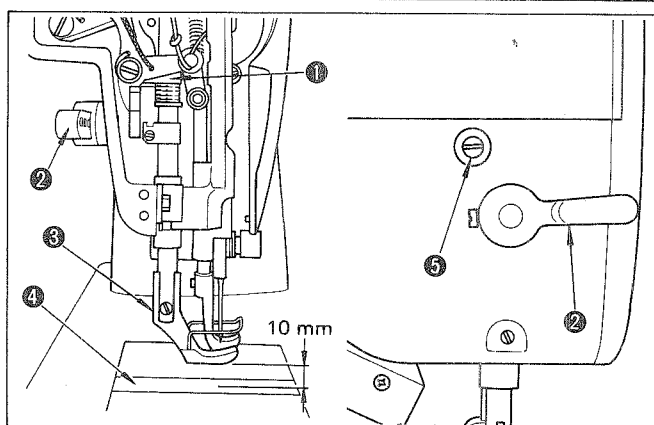

Loosen screw ⑤ and adjust the position of hand lifter mounting bracket ① so a 10 mm clearance is produced between presser foot ③ and throat plate ④ when the presser foot is raised by hand lifter ②.

34. PEDAL PRESSURE AND STROKE (For LU-1114-5)

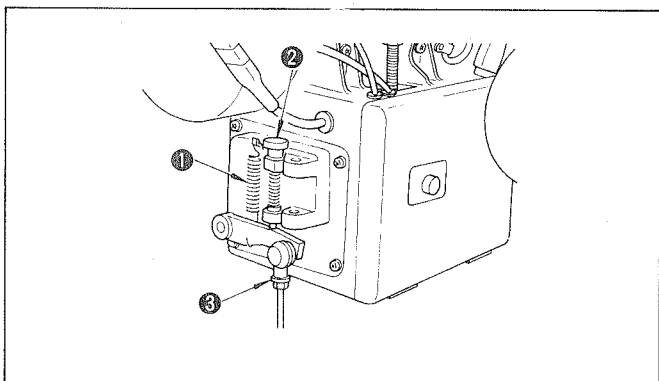

★ Adjusting the forward pedaling (toe down) pressure

The forward pedaling pressure can be adjusted by hooking adjusting spring ① on the right or left side. When the spring is hooked on the left side, the pedal resistance reduces. When it is hooked on the right side the pedal resistance increases.

★ Adjusting the backward pedaling (heel down) pressure

This can be achieved by adjusting crew ②. When the adjusting screw is tightened, the pedal resistance increases. When it is loosened, the pedal resistance reduces.

★ Adjusting the forward pedaling stroke

When connecting rod ③ is inserted into the hole on the left side, the stroke is reduced.

35. REVERSE FEED SWITCH LEVER

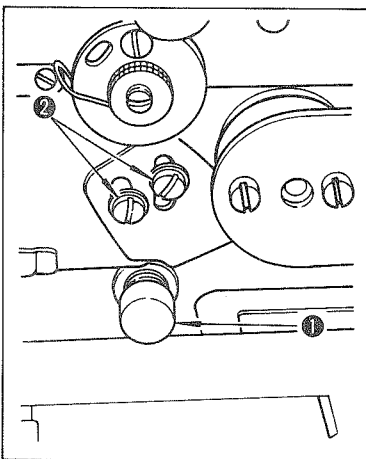

★ How to use

1. Depress switch ①, and the machine will immediately run in the reverse direction.
2. Reverse stitch is made as long as you keep depressing the switch lever.
3. Release the switch for forward sewing.

★ Position of the switch

Adjust the position of the switch for your convenience. Loosen screw ② and adjust the position as desired.

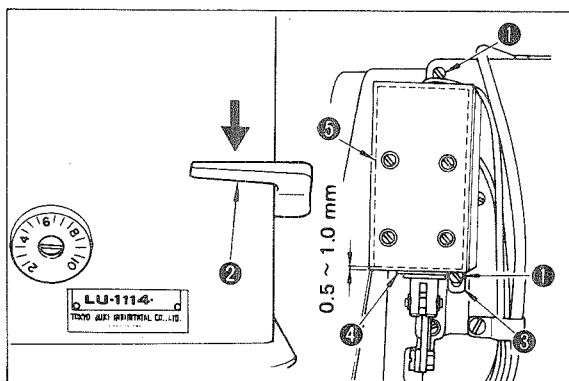

★ Position of the reverse feed solenoid

1. Set the stitch dial to the maximum value.
2. Loosen screws ① which fix the solenoid in place.
3. Depress switch lever ② fully downwards, provide a 0.5 to 1.0 mm (1/64" to 3/64") clearance between solenoid ⑤ and resilient plate ④ on the plunger by moving solenoid bracket ③ up and down and tighten screws ①.

36. TROUBLES AND CORRECTIVE MEASURES

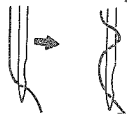
TROUBLES	CAUSES	CORRECTIVE MEASURES
<p>1. Thread breakage (Thread is untwisted or scraped)</p> <p>(Needle thread 20 to 30 mm (approx. 1") is left on the wrong side of the fabric.)</p>	<p>① There is a sharp edges or burrs on the thread path, needle point, hook blade point or bobbin case resting groove on the throat plate.</p> <p>② Needle thread tension is too high.</p> <p>③ Bobbin case opening lever provides an excessive clearance at the bobbin case.</p> <p>④ Hook blade point hits the needle.</p> <p>⑤ Hook is not lubricated properly.</p> <p>⑥ Needle thread tension is too low.</p> <p>⑦ Thread take-up spring is too tight and its stroke is too small.</p> <p>⑧ Needle-to-hook relation is wrong.</p>	<p>○ Remove sharp edges or burrs using a fine sandpaper. Polish the surface of the bobbin case resting groove on the throat plate using a buffing wheel.</p> <p>○ Adjust the needle thread tension.</p> <p>○ See 26 and adjust the clearance.</p> <p>○ Adjust the needle-to-hook relation according to 24.</p> <p>○ Increase the amount of oil supplied to the hook according to 2.</p> <p>○ Adjust the needle thread tension.</p> <p>○ Reduce the tension of the spring and increase the stroke.</p> <p>○ Adjust the needle-to-hook relation according to 24.</p>
<p>2. Stitch skipping</p>	<p>① Clearance between the needle and the hook blade point is too great.</p> <p>② Needle-to-hook relation is wrong.</p> <p>③ Pressing force of the presser foot is not enough.</p> <p>④ The clearance between the top end and the hook blade point is not correct.</p> <p>⑤ Hook needle guard is not functional.</p> <p>⑥ Needles are a little too thin.</p> <p>⑦ Synthetic thread or thin thread.</p>	<p>○ Adjust the needle-to-hook relation according to 24.</p> <p>○ Adjust the needle-to-hook relation according to 24.</p> <p>○ Tighten the presser spring regulator.</p> <p>○ Adjust the needle bar height according to 24.</p> <p>○ Adjust the position of the hook needle guard according to 25.</p> <p>○ Replace the needles by thicker ones.</p> <p>○ </p>
<p>3. Loose stitch.</p>	<p>① Bobbin thread does not pass through the forked end of the tension spring on the bobbin case.</p> <p>② Thread path has rough surface.</p> <p>③ Bobbin does not spin smoothly.</p> <p>④ Bobbin case opening lever provides too much clearance at the bobbin.</p> <p>⑤ Bobbin thread tension is too low.</p> <p>⑥ Bobbin is wound too tightly.</p>	<p>○ Thread the bobbin case correctly.</p> <p>○ Remove rough surface using a fine sandpaper or polish the surface using a buffing wheel.</p> <p>○ Replace the bobbin or the hook.</p> <p>○ Adjust the bobbin case opening lever according to 26.</p> <p>○ Adjust the bobbin thread tension.</p> <p>○ Adjust the tension components on the thread winder.</p>
<p>4. Thread escapes from the needle eye after thread trimming action.</p>	<p>① Thread tension given by the tension post No. 1 is too high.</p> <p>② Timing of the thread trimming action is too early.</p>	<p>○ Loosen tension post No. 1 slightly.</p> <p>○ Adjust the thread trimmer cam according to 28.</p>
<p>5. Thread escapes from the needle eye at the start of stitching.</p>	<p>① Thread tension given by the tension post No. 1 is too high.</p> <p>② Pressure of the clamp spring is wrong.</p> <p>③ Needle hole in the presser foot is too large compared to the stitch length.</p> <p>④ Bobbin thread tension is too low.</p> <p>⑤ The size of the feed dog needle hole and the stitch length are improper.</p>	<p>○ Loosen the tension post No. 1 slightly.</p> <p>○ Adjust the clamp spring pressure or replace it.</p> <p>○ Replace the presser foot having a smaller needle hole.</p> <p>○ Increase the bobbin thread tension.</p> <p>○ Replace the feed dog.</p>
<p>6. Thread is not cut sharply.</p>	<p>① Position of the moving knife to the fixed knife is wrong.</p> <p>② Thread trimmer knife is chipped or worn.</p> <p>③ Moving knife tilts wrongly.</p>	<p>○ Adjust the position of the moving knife and clamp spring according to 27, 29 and 30.</p> <p>○ Resharpen or replace the knife blade.</p> <p>○ Adjust the moving knife according to 27 and 29.</p>
<p>7. Thread is not cut at all.</p> <p>(When stitch length is small, bobbin thread is not cut.)</p>	<p>① Initial position of the moving knife is wrong.</p> <p>② Moving knife does not come back to the blade of the fixed knife.</p> <p>③ Timing of the thread trimming action is wrong.</p> <p>④ Needle hole in the feed dog is too large compared to stitch length.</p>	<p>○ Adjust the initial position of the moving knife according to 27.</p> <p>○ Adjust the thread trimmer cam according to 28.</p> <p>○ Adjust the thread trimmer cam according to 28.</p> <p>○ Replace the feed dog.</p>
<p>8. The thread breaks at the stitching start after thread trimming.</p>	<p>① The needle thread is caught in the hook.</p>	<p>○ Shorten the thread remaining on the needle. See "21. Thread tension"</p>

37. TABLE OF SEWING SPEED FOR EACH STITCH LENGTH

Stitch length	Max. sewing speed	Normal sewing speed
4 mm or less	2500 s.p.m.	2300 s.p.m.
Over 4 mm up to 7 mm inclusive	2000 s.p.m.	1800 s.p.m.
Over 7 mm up to 10 mm inclusive	1500 s.p.m.	1300 s.p.m.

*The maximum sewing speed of 2800 s.p.m. applies only to sewing vinyl leather or similar materials in a stitch length of 4 mm or less.

38. SEWING HEAVY-WEIGHT MATERIAL (FOR LU-1114-5)

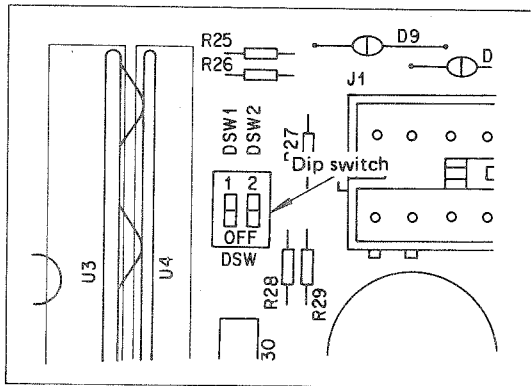

When sewing heavy-weight material, if the motor produces "clatter" while the sewing machine is running at low speed, set the dip switch 2 in the PSC box to ON. For normal operation, the dip switch should be set to OFF.

39. MOTOR PULLEY AND V BELT

Outer diameter of the motor pulley	Part No. of motor pulley	Revolution		Belt length	Part No. of belt
		50 Hz	60 Hz		
110 mm	MTS-P01050A0	2300 s.p.m.		44"	MTJ-VM004400
90	MTS-P00850A0		2300 s.p.m.	43"	MTJ-VM004300

(Note) The holes in the motor pulley are tapered. Therefore, commercially available pulleys cannot be used. The effective motor pulley diameter is obtained by subtracting 5 mm from the outer diameter.

(How to install)

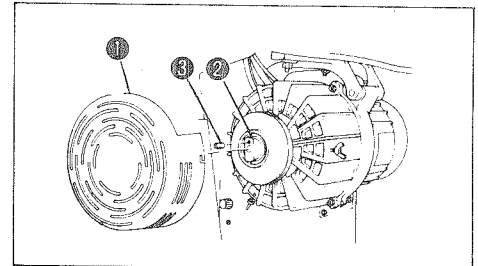

Remove pulley cover ①, fit the motor shaft key into the pulley key groove, tighten pulley nut ②, and then pulley nut screw ③. To remove the pulley, first remove the pulley cover, and perform the procedures in the reverse sequence to that of mounting.

MEMO

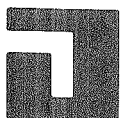
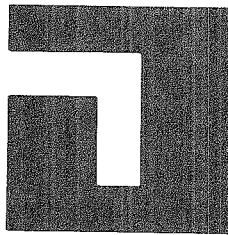

TOKYO JUKI INDUSTRIAL CO., LTD.

Head Office & Plant: 2-1, 8-chome, Kokuryo-cho, Chofu-shi, Tokyo, Japan
Business Office: 23-3, Kabuki-cho 1-chome, Shinjuku-ku, Tokyo 160, Japan
Cable: JUKI TOKYO Telex: J22967, 232-2301

(Please do not hesitate to contact our distributors or agents in your area for further informations when necessary.)

Appear and specification listed in this instruction book are subjected to change without notice.